



A D T

# FCC TEST REPORT

**REPORT NO.:** RF980729L08

**MODEL NO.:** JWNR2000

**RECEIVED:** Jul. 29, 2009

**TESTED:** Aug. 04 ~ Aug. 14, 2009

**ISSUED:** Aug. 19, 2009

**APPLICANT:** NETGEAR, INC.

**ADDRESS:** 350 East Plumeria Drive San Jose, CA 95134

**ISSUED BY:** Bureau Veritas Consumer Products Services  
(H.K.) Ltd., Taoyuan Branch

**LAB ADDRESS:** No. 47, 14th Ling, Chia Pau Tsuen, Lin Kou  
Hsiang, Taipei Hsien 244, Taiwan, R.O.C.

**TEST LOCATION:** No. 19, Hwa Ya 2nd Rd, Wen Hwa Tsuen, Kwei  
Shan Hsiang, Taoyuan Hsien 333, Taiwan,  
R.O.C.

This test report consists of 90 pages in total. It may be duplicated completely for legal use with the approval of the applicant. It should not be reproduced except in full, without the written approval of our laboratory. The client should not use it to claim product endorsement by TAF or any government agencies. The test results in the report only apply to the tested sample.





# TABLE OF CONTENTS

1.	CERTIFICATION.....	4
2.	SUMMARY OF TEST RESULTS .....	5
2.1	MEASUREMENT UNCERTAINTY.....	5
3.	GENERAL INFORMATION.....	6
3.1	GENERAL DESCRIPTION OF EUT .....	6
3.2	DESCRIPTION OF TEST MODES .....	8
3.2.1	CONFIGURATION OF SYSTEM UNDER TEST .....	8
3.2.2	TEST MODE APPLICABILITY AND TESTED CHANNEL DETAIL .....	9
3.3	GENERAL DESCRIPTION OF APPLIED STANDARDS .....	11
3.4	DESCRIPTION OF SUPPORT UNITS .....	11
4.	TEST TYPES AND RESULTS .....	12
4.1	RADIATED EMISSION MEASUREMENT .....	12
4.1.1	LIMITS OF RADIATED EMISSION MEASUREMENT.....	12
4.1.2	TEST INSTRUMENTS.....	13
4.1.3	TEST PROCEDURES .....	14
4.1.4	DEVIATION FROM TEST STANDARD.....	14
4.1.5	TEST SETUP.....	15
4.1.6	EUT OPERATING CONDITIONS .....	15
4.1.7	TEST RESULTS .....	16
4.2	CONDUCTED EMISSION MEASUREMENT .....	30
4.2.1	LIMITS OF CONDUCTED EMISSION MEASUREMENT .....	30
4.2.2	TEST INSTRUMENTS.....	30
4.2.3	TEST PROCEDURES .....	31
4.2.4	DEVIATION FROM TEST STANDARD.....	31
4.2.5	TEST SETUP.....	32
4.2.6	EUT OPERATING CONDITIONS .....	32
4.2.7	TEST RESULTS .....	33
4.3	6dB BANDWIDTH MEASUREMENT.....	37
4.3.1	LIMITS OF 6dB BANDWIDTH MEASUREMENT .....	37
4.3.2	TEST INSTRUMENTS.....	37
4.3.3	TEST PROCEDURE.....	37
4.3.4	DEVIATION FROM TEST STANDARD.....	37
4.3.5	TEST SETUP.....	38
4.3.6	EUT OPERATING CONDITIONS .....	38
4.3.7	TEST RESULTS .....	39
4.4	MAXIMUM PEAK OUTPUT POWER.....	51
4.4.1	LIMITS OF MAXIMUM PEAK OUTPUT POWER MEASUREMENT .....	51
4.4.2	INSTRUMENTS.....	51
4.4.3	TEST PROCEDURES .....	51
4.4.4	DEVIATION FROM TEST STANDARD.....	52
4.4.5	TEST SETUP.....	52
4.4.6	EUT OPERATING CONDITIONS .....	52
4.4.7	TEST RESULTS .....	53
4.5	POWER SPECTRAL DENSITY MEASUREMENT .....	55
4.5.1	LIMITS OF POWER SPECTRAL DENSITY MEASUREMENT .....	55
4.5.2	TEST INSTRUMENTS.....	55
4.5.3	TEST PROCEDURE.....	55
4.5.4	DEVIATION FROM TEST STANDARD.....	56



A D T

4.5.5	TEST SETUP .....	56
4.5.6	EUT OPERATING CONDITION.....	56
4.5.7	TEST RESULTS .....	57
4.6	BAND EDGES MEASUREMENT .....	69
4.6.1	LIMITS OF BAND EDGES MEASUREMENT .....	69
4.6.2	TEST INSTRUMENTS.....	69
4.6.3	TEST PROCEDURE.....	70
4.6.4	DEVIATION FROM TEST STANDARD.....	70
4.6.5	EUT OPERATING CONDITION.....	70
4.6.6	TEST RESULTS .....	71
4.7	ANTENNA REQUIREMENT .....	87
4.7.1	STANDARD APPLICABLE .....	87
4.7.2	ANTENNA CONNECTED CONSTRUCTION .....	87
5.	PHOTOGRAPHS OF THE TEST CONFIGURATION.....	88
6.	INFORMATION ON THE TESTING LABORATORIES .....	89
7.	APPENDIX A - MODIFICATIONS RECORDERS FOR ENGINEERING CHANGES TO THE EUT BY THE LAB.....	90



A D T

## 1. CERTIFICATION

**PRODUCT:** WIRELESS-N ROUTER  
**MODEL:** JWNR2000  
**BRAND:** NETGEAR  
**APPLICANT:** NETGEAR, INC.  
**TEST SAMPLE:** ENGINEERING SAMPLE  
**TESTED:** Aug. 04 ~ Aug. 14, 2009  
**STANDARDS:** **FCC Part 15, Subpart C (Section 15.247)**  
ANSI C63.4-2003

The above equipment (Model: JWNR2000) has been tested by **Bureau Veritas Consumer Products Services (H.K.) Ltd., Taoyuan Branch**, and found compliance with the requirement of the above standards. The test record, data evaluation & Equipment Under Test (EUT) configurations represented herein are true and accurate accounts of the measurements of the sample's EMC characteristics under the conditions specified in this report.

**PREPARED BY** : Polly Chien , **DATE** : Aug. 19, 2009  
Polly Chien / Specialist

**TECHNICAL ACCEPTANCE** : Long Chen , **DATE** : Aug. 19, 2009  
Responsible for RF Long Chen / Senior Engineer

**APPROVED BY** : Gary Chang , **DATE** : Aug. 19, 2009  
Gary Chang / Assistant Manager



## 2. SUMMARY OF TEST RESULTS

The EUT has been tested according to the following specifications:

APPLIED STANDARD: FCC PART 15, SUBPART C (SECTION 15.247)			
STANDARD SECTION	TEST TYPE AND LIMIT	RESULT	REMARK
15.207	AC Power Conducted Emission	PASS	Meet the requirement of limit. Minimum passing margin is -14.00dB at 0.749MHz.
15.247(a)(2)	Spectrum Bandwidth of a Direct Sequence Spread Spectrum System Limit: min. 500kHz	PASS	Meet the requirement of limit.
15.247(b)	Maximum Peak Output Power Limit: max. 30dBm	PASS	Meet the requirement of limit.
15.247(d)	Radiated Emissions Limit: Table 15.209	PASS	Meet the requirement of limit. Minimum passing margin is -1.03dB at 4924.00MHz.
15.247(e)	Power Spectral Density Limit: max. 8dBm	PASS	Meet the requirement of limit.
15.247(d)	Band Edge Measurement Limit: 20dB less than the peak value of fundamental frequency	PASS	Meet the requirement of limit.

### 2.1 MEASUREMENT UNCERTAINTY

Where relevant, the following measurement uncertainty levels have been estimated for tests performed on the EUT as specified in CISPR 16-4-2:

MEASUREMENT	FREQUENCY	UNCERTAINTY
Conducted emissions	150kHz~30MHz	2.44 dB
Radiated emissions	30MHz ~ 200MHz	3.19 dB
	200MHz ~1000MHz	3.21 dB
	1GHz ~ 18GHz	2.26 dB
	18GHz ~ 40GHz	1.94 dB

This uncertainty represents an expanded uncertainty expressed at approximately the 95% confidence level using a coverage factor of  $k = 2$ .



### 3. GENERAL INFORMATION

#### 3.1 GENERAL DESCRIPTION OF EUT

<b>EUT</b>	WIRELESS-N ROUTER
<b>MODEL NO.</b>	JWNR2000
<b>FCC ID</b>	PY309100106
<b>POWER SUPPLY</b>	12Vdc from AC Adapter
<b>MODULATION TYPE</b>	CCK, DQPSK, DBPSK for DSSS 64QAM, 16QAM, QPSK, BPSK for OFDM
<b>MODULATION TECHNOLOGY</b>	DSSS, OFDM
<b>TRANSFER RATE</b>	802.11b: 11.0/ 5.5/ 2.0/ 1.0Mbps 802.11g: 54.0/ 48.0/ 36.0/ 24.0/ 18.0/ 12.0/ 9.0/ 6.0Mbps Draft 802.11n: up to 300.0Mbps
<b>OPERATING FREQUENCY</b>	2412.0 ~ 2462.0MHz
<b>NUMBER OF CHANNEL</b>	11 for 802.11b, 802.11g, draft 802.11n (20MHz) 7 for draft 802.11n (40MHz)
<b>OUTPUT POWER</b>	217.77mW
<b>ANTENNA TYPE</b>	Printed antenna with 2.77dBi gain
<b>DATA CABLE</b>	NA
<b>I/O PORTS</b>	RJ45
<b>ACCESSORY DEVICES</b>	Adapter

**NOTE:**

1. The EUT incorporates a MIMO function. Physically, the EUT provides two completed transmitters and two receivers.

<b>MODULATION MODE</b>	<b>TX / RX FUNCTION</b>	<b>TX ANTENNA</b>	<b>RX ANTENNA</b>
<b>802.11b</b>	1TX / 1RX	Only Ant A	Ant A or B
<b>802.11g</b>	1TX / 1RX	Ant A or B	Ant A or B
<b>Draft 802.11n (20MHz)</b>	1TX / 2RX 2TX / 2RX	1 TX : Ant A or B 2 TX : Ant A & B	Ant A & B
<b>Draft 802.11n (40MHz)</b>	1TX / 2RX 2TX / 2RX	1 TX : Ant A or B 2 TX : Ant A & B	Ant A & B



A D T

2. The EUT was powered by the following adapters:

ADAPTER 1	
<b>BRAND:</b>	NETGEAR
<b>MODEL:</b>	T012LF1209 16100-2LF
<b>P/N:</b>	332-10166-01
<b>INPUT POWER:</b>	100-120Vac, 50/60Hz, 0.5A
<b>OUTPUT POWER:</b>	12Vdc, 1A
<b>POWER LINE:</b>	1.8m non-shielded cable without core

ADAPTER 2	
<b>BRAND:</b>	NETGEAR
<b>MODEL:</b>	MT12-Y120100-A1
<b>P/N:</b>	332-10190-01
<b>INPUT POWER:</b>	100-120Vac, 60Hz, 0.3A
<b>OUTPUT POWER:</b>	12Vdc, 1A
<b>POWER LINE:</b>	1.8m non-shielded cable without core

3. The above EUT information was declared by manufacturer and for more detailed features description, please refer to the manufacturer's specifications or user's manual.

### 3.2 DESCRIPTION OF TEST MODES

11 channels are provided for 802.11b, 802.11g and draft 802.11n (20MHz):

CHANNEL	FREQUENCY	CHANNEL	FREQUENCY
1	2412MHz	7	2442MHz
2	2417MHz	8	2447MHz
3	2422MHz	9	2452MHz
4	2427MHz	10	2457MHz
5	2432MHz	11	2462MHz
6	2437MHz		

7 channels are provided for draft 802.11n (40MHz):

CHANNEL	FREQUENCY	CHANNEL	FREQUENCY
1	2422MHz	5	2442MHz
2	2427MHz	6	2447MHz
3	2432MHz	7	2452MHz
4	2437MHz		

#### 3.2.1 CONFIGURATION OF SYSTEM UNDER TEST

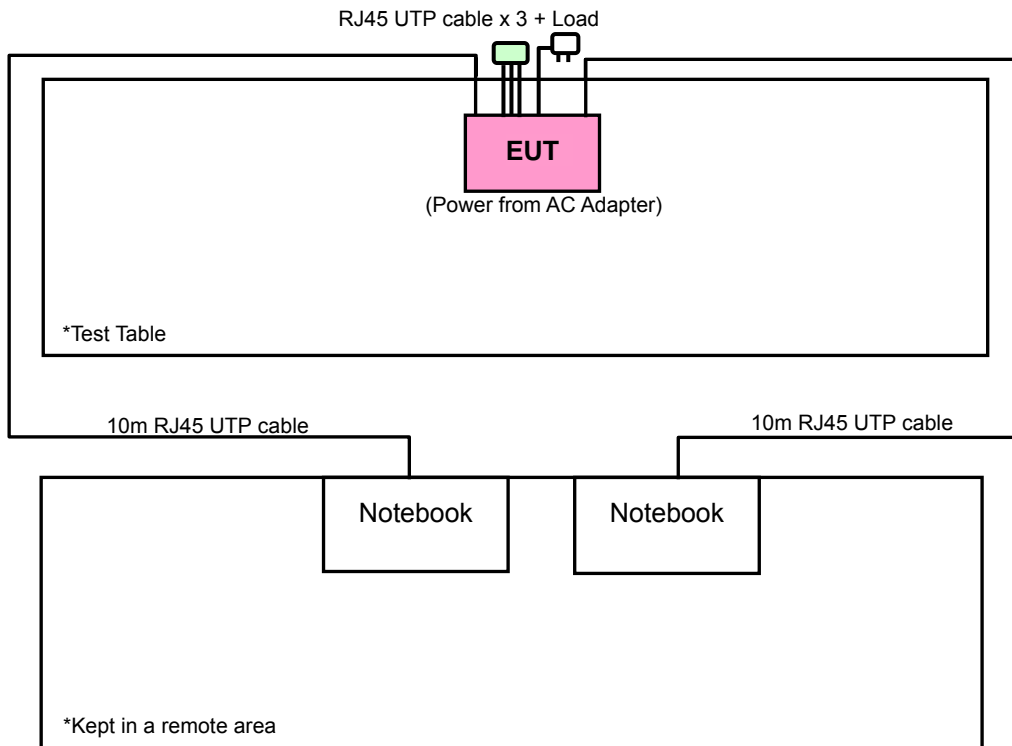





### 3.2.2 TEST MODE APPLICABILITY AND TESTED CHANNEL DETAIL

EUT CONFIGURE MODE	APPLICABLE TO				DESCRIPTION
	RE $\geq$ 1G	RE<1G	PLC	APCM	
A	√	√	√	√	Adapter: T012LF1209 16100-2LF
B	-	√	√	-	Adapter: MT12-Y120100-A1

Where **RE $\geq$ 1G**: Radiated Emission above 1GHz      **RE<1G**: Radiated Emission below 1GHz  
**PLC**: Power Line Conducted Emission      **APCM**: Antenna Port Conducted Measurement

**NOTE 1**: After pretesting of emission, Antenna B is worse than Antenna A. Therefore, Antenna B was chosen for final test for 11g mode.

**NOTE 2**: Conducted power of single TX chain has no different when operating at 1 TX or 2 TX mode. Therefore, only 2 TX mode will be tested for 802.11n.

**NOTE 3**: “-“ means no effect.

#### RADIATED EMISSION TEST (ABOVE 1GHz):

- Pre-Scan has been conducted to determine the worst-case mode from all possible combinations between available modulations, data rates, XYZ axis and antenna ports (if EUT with antenna diversity architecture).
- Following channel(s) was (were) selected for the final test as listed below.

EUT CONFIGURE MODE	MODE	AVAILABLE CHANNEL	TESTED CHANNEL	MODULATION TECHNOLOGY	MODULATION TYPE	DATA RATE (Mbps)	AXIS	ANT.
A	802.11b	1 to 11	1, 6, 11	DSSS	DBPSK	1.0	Z	A
A	802.11g	1 to 11	1, 6, 11	OFDM	BPSK	6.0	Z	B
A	Draft 802.11n (20MHz)	1 to 11	1, 6, 11	OFDM	BPSK	7.2	Z	A+B
A	Draft 802.11n (40MHz)	1 to 7	1, 4, 7	OFDM	BPSK	15.0	Z	A+B

#### RADIATED EMISSION TEST (BELOW 1GHz):

- Pre-Scan has been conducted to determine the worst-case mode from all possible combinations between available modulations, data rates, XYZ axis and antenna ports (if EUT with antenna diversity architecture).
- Following channel(s) was (were) selected for the final test as listed below.

EUT CONFIGURE MODE	MODE	AVAILABLE CHANNEL	TESTED CHANNEL	MODULATION TECHNOLOGY	MODULATION TYPE	DATA RATE (Mbps)	AXIS	ANT.
A, B	Draft 802.11n (20MHz)	1 to 11	1	OFDM	BPSK	7.2	Z	A+B



A D T

### **POWER LINE CONDUCTED EMISSION TEST:**

- Pre-Scan has been conducted to determine the worst-case mode from all possible combinations between available modulations, data rates and antenna ports (if EUT with antenna diversity architecture).
- Following channel(s) was (were) selected for the final test as listed below.

EUT CONFIGURE MODE	MODE	AVAILABLE CHANNEL	TESTED CHANNEL	MODULATION TECHNOLOGY	MODULATION TYPE	DATA RATE (Mbps)	ANT.
A, B	Draft 802.11n (20MHz)	1 to 11	1	OFDM	BPSK	7.2	A+B

### **BANDEDGE MEASUREMENT:**

- Pre-Scan has been conducted to determine the worst-case mode from all possible combinations between available modulations, data rates, XYZ axis and antenna ports (if EUT with antenna diversity architecture).
- Following channel(s) was (were) selected for the final test as listed below.

EUT CONFIGURE MODE	MODE	AVAILABLE CHANNEL	TESTED CHANNEL	MODULATION TECHNOLOGY	MODULATION TYPE	DATA RATE (Mbps)	AXIS	ANT.
A	802.11b	1 to 11	1, 11	DSSS	DBPSK	1.0	Z	A
A	802.11g	1 to 11	1, 11	OFDM	BPSK	6.0	Z	B
A	Draft 802.11n (20MHz)	1 to 11	1, 11	OFDM	BPSK	7.2	Z	A+B
A	Draft 802.11n (40MHz)	1 to 7	1, 7	OFDM	BPSK	15.0	Z	A+B

### **ANTENNA PORT CONDUCTED MEASUREMENT:**

- Pre-Scan has been conducted to determine the worst-case mode from all possible combinations between available modulations, data rates and antenna ports (if EUT with antenna diversity architecture).
- Following channel(s) was (were) selected for the final test as listed below.

EUT CONFIGURE MODE	MODE	AVAILABLE CHANNEL	TESTED CHANNEL	MODULATION TECHNOLOGY	MODULATION TYPE	DATA RATE (Mbps)	ANT.
A	802.11b	1 to 11	1, 6, 11	DSSS	DBPSK	1.0	A
A	802.11g	1 to 11	1, 6, 11	OFDM	BPSK	6.0	B
A	Draft 802.11n (20MHz)	1 to 11	1, 6, 11	OFDM	BPSK	7.2	A+B
A	Draft 802.11n (40MHz)	1 to 7	1, 4, 7	OFDM	BPSK	15.0	A+B



A D T

### 3.3 GENERAL DESCRIPTION OF APPLIED STANDARDS

The EUT is a RF Product. According to the specifications of the manufacturer, it must comply with the requirements of the following standards:

#### FCC Part 15, Subpart C (15.247)

#### ANSI C63.4-2003

All test items have been performed and recorded as per the above standards.

**NOTE:** The EUT is also considered as a kind of computer peripheral, because the connection to computer is necessary for typical use. It has been verified to comply with the requirements of FCC Part 15, Subpart B, Class B (DoC). The test report has been issued separately.

### 3.4 DESCRIPTION OF SUPPORT UNITS

The EUT has been tested as an independent unit together with other necessary accessories or support units. The following support units or accessories were used to form a representative test configuration during the tests.

NO.	PRODUCT	BRAND	MODEL NO.	SERIAL NO.	FCC ID
1	NOTEBOOK	DELL	D600	CN-0G5152-4864 3-47H-7666	E2K24CLNS
2	NOTEBOOK	DELL	PP05L	33898721680	E2K24CLNS

NO.	SIGNAL CABLE DESCRIPTION OF THE ABOVE SUPPORT UNITS
1	10m UTP RJ45 cable.
2	10m UTP RJ45 cable.

**NOTE:** 1. All power cords of the above support units are non shielded (1.8m).  
2. Items 1-2 acted as communication partners to transfer data.



A D T

## 4. TEST TYPES AND RESULTS

### 4.1 RADIATED EMISSION MEASUREMENT

#### 4.1.1 LIMITS OF RADIATED EMISSION MEASUREMENT

Emissions radiated outside of the specified bands, shall be according to the general radiated limits in 15.209 as following:

FREQUENCIES (MHz)	FIELD STRENGTH (microvolts/meter)	MEASUREMENT DISTANCE (meters)
0.009 ~ 0.490	2400/F(kHz)	300
0.490 ~ 1.705	24000/F(kHz)	30
1.705 ~ 30.0	30	30
30 ~ 88	100	3
88 ~ 216	150	3
216 ~ 960	200	3
Above 960	500	3

**NOTE:**

1. The lower limit shall apply at the transition frequencies.
2. Emission level (dBuV/m) = 20 log Emission level (uV/m).
3. As shown in 15.35(b), for frequencies above 1000MHz, the field strength limits are based on average detector, however, the peak field strength of any emission shall not exceed the maximum permitted average limits, specified above by more than 20dB under any condition of modulation.



A D T

#### 4.1.2 TEST INSTRUMENTS

DESCRIPTION & MANUFACTURER	MODEL NO.	SERIAL NO.	DATE OF CALIBRATION	DUE DATE OF CALIBRATION
Test Receiver ROHDE & SCHWARZ	ESI7	838496/016	Dec. 29, 2008	Dec. 28, 2009
Spectrum Analyzer ROHDE & SCHWARZ	FSP40	100039	Dec. 08, 2008	Dec. 07, 2009
BILOG Antenna SCHWARZBECK	VULB9168	9168-155	Apr. 29, 2009	Apr. 28, 2010
HORN Antenna SCHWARZBECK	BBHA 9120D	9120D-408	Dec. 29, 2008	Dec. 28, 2009
HORN Antenna SCHWARZBECK	BBHA 9170	BBHA9170242	Jan. 06, 2009	Jan. 05, 2010
Preamplifier Agilent	8449B	3008A01960	Nov. 03, 2008	Nov. 02, 2009
Preamplifier Agilent	8447D	2944A10631	Nov. 03, 2008	Nov. 02, 2009
RF signal cable HUBER+SUHNNER	SUCOFLEX 104	274041/4	Aug. 21, 2008	Aug. 20, 2009
RF signal cable HUBER+SUHNNER	SUCOFLEX 104	283397/4	Aug. 21, 2008	Aug. 20, 2009
Software ADT.	ADT_Radiated_ V7.6.15.9.2	NA	NA	NA
Antenna Tower inn-co GmbH	MA 4000	010303	NA	NA
Antenna Tower Controller inn-co GmbH	CO2000	019303	NA	NA
Turn Table ADT.	TT100.	TT93021704	NA	NA
Turn Table Controller ADT.	SC100.	SC93021704	NA	NA

- NOTE:**
1. The calibration interval of the above test instruments is 12 months and the calibrations are traceable to NML/ROC and NIST/USA.
  2. The test was performed in HwaYa Chamber 4.
  3. The horn antenna and HP preamplifier (model: 8449B) are used only for the measurement of emission frequency above 1GHz if tested.
  4. The FCC Site Registration No. is 988962.
  5. The IC Site Registration No. is IC7450F-4.



#### 4.1.3 TEST PROCEDURES

- a. The EUT was placed on the top of a rotating table 0.8 meters above the ground at a 3 meters semi-anechoic chamber. The table was rotated 360 degrees to determine the position of the highest radiation.
- b. The EUT was set 3 meters away from the interference-receiving antenna, which was mounted on the top of a variable-height antenna tower.
- c. The antenna is a broadband antenna, and its height is varied from one meter to four meters above the ground to determine the maximum value of the field strength. Both horizontal and vertical polarizations of the antenna are set to make the measurement.
- d. For each suspected emission, the EUT was arranged to its worst case and then the antenna was tuned to heights from 1 meter to 4 meters and the rotatable table was turned from 0 degrees to 360 degrees to find the maximum reading.
- e. The test-receiver system was set to Peak Detect Function and Specified Bandwidth with Maximum Hold Mode.
- f. If the emission level of the EUT in peak mode was lower than the limit specified, then testing could be stopped and the peak values of the EUT would be reported. Otherwise the emissions would be re-tested one by one using peak, quasi-peak or average method as specified and then reported in a data sheet.

**NOTE:**

1. The resolution bandwidth and video bandwidth of test receiver/spectrum analyzer is 120kHz for Quasi-peak detection at frequency below 1GHz.
2. The resolution bandwidth of test receiver/spectrum analyzer is 1MHz and video bandwidth is 3MHz for Peak detection at frequency above 1GHz.
3. The resolution bandwidth of test receiver/spectrum analyzer is 1MHz and the video bandwidth is 10Hz for Average detection (AV) at frequency above 1GHz.
4. All modes of operation were investigated and the worst-case emissions are reported.

#### 4.1.4 DEVIATION FROM TEST STANDARD

No deviation.

#### 4.1.5 TEST SETUP

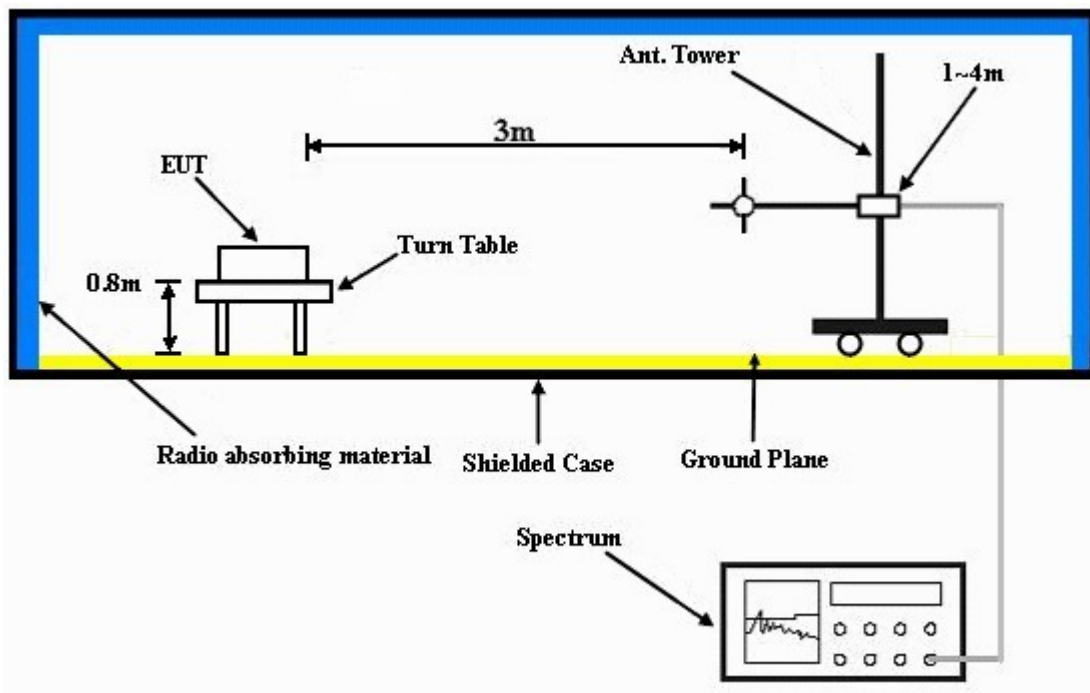

For the actual test configuration, please refer to the attached file (Test Setup Photo).

#### 4.1.6 EUT OPERATING CONDITIONS

- a. Placed the EUT on the testing table.
- b. Prepared notebook systems to act as a communication partner and placed them outside of testing area.
- c. The communication partners connected with EUT via a UTP cable and run a test program (provided by manufacturer) to enable EUT under transmission condition continuously at specific channel frequency.
- d. The communication partners sent data to EUT by command "PING".



A D T

#### 4.1.7 TEST RESULTS

##### 802.11b DSSS MODULATION

EUT TEST CONDITION		MEASUREMENT DETAIL	
CHANNEL	Channel 1	FREQUENCY RANGE	1 ~ 25GHz
INPUT POWER	120Vac, 60 Hz	DETECTOR FUNCTION	Peak (PK) Average (AV)
ENVIRONMENTAL CONDITIONS	25deg. C, 68%RH 1000 hPa	TESTED BY	Sun Lin
TEST MODE	A		

ANTENNA POLARITY & TEST DISTANCE: HORIZONTAL AT 3 M								
NO.	FREQ. (MHz)	EMISSION LEVEL (dBuV/m)	LIMIT (dBuV/m)	MARGIN (dB)	ANTENNA HEIGHT (m)	TABLE ANGLE (Degree)	RAW VALUE (dBuV)	CORRECTION FACTOR (dB/m)
1	2386.00	53.12 PK	74.00	-20.88	2.01 H	241	20.85	32.27
2	2386.00	43.07 AV	54.00	-10.93	2.01 H	241	10.80	32.27
3	*2412.00	105.20 PK			2.04 H	235	72.82	32.38
4	*2412.00	100.46 AV			2.04 H	235	68.08	32.38
5	4824.00	52.00 PK	74.00	-22.00	1.24 H	50	13.43	38.56
6	4824.00	44.46 AV	54.00	-9.54	1.24 H	50	5.89	38.56
ANTENNA POLARITY & TEST DISTANCE: VERTICAL AT 3 M								
NO.	FREQ. (MHz)	EMISSION LEVEL (dBuV/m)	LIMIT (dBuV/m)	MARGIN (dB)	ANTENNA HEIGHT (m)	TABLE ANGLE (Degree)	RAW VALUE (dBuV)	CORRECTION FACTOR (dB/m)
1	2386.00	57.86 PK	74.00	-16.14	1.22 V	247	25.59	32.27
2	2386.00	46.92 AV	54.00	-7.08	1.22 V	247	14.65	32.27
3	*2412.00	110.05 PK			1.27 V	193	77.67	32.38
4	*2412.00	105.26 AV			1.27 V	193	72.88	32.38
5	4824.00	57.72 PK	74.00	-16.28	1.23 V	87	19.15	38.56
6	4824.00	52.91 AV	54.00	-1.09	1.23 V	87	14.35	38.56

- REMARKS:**
1. Emission level (dBuV/m) = Raw Value (dBuV) + Correction Factor (dB/m).
  2. Correction Factor (dB/m) = Antenna Factor (dB/m) + Cable Factor (dB).
  3. The other emission levels were very low against the limit.
  4. Margin value = Emission level – Limit value.
  5. “ \* “: Fundamental frequency.





A D T

EUT TEST CONDITION		MEASUREMENT DETAIL	
CHANNEL	Channel 6	FREQUENCY RANGE	1 ~ 25GHz
INPUT POWER	120Vac, 60 Hz	DETECTOR FUNCTION	Peak (PK) Average (AV)
ENVIRONMENTAL CONDITIONS	25deg. C, 68%RH 1000 hPa	TESTED BY	Sun Lin
TEST MODE	A		

ANTENNA POLARITY & TEST DISTANCE: HORIZONTAL AT 3 M								
NO.	FREQ. (MHz)	EMISSION LEVEL (dBuV/m)	LIMIT (dBuV/m)	MARGIN (dB)	ANTENNA HEIGHT (m)	TABLE ANGLE (Degree)	RAW VALUE (dBuV)	CORRECTION FACTOR (dB/m)
1	*2437.00	105.02 PK			2.02 H	235	72.54	32.48
2	*2437.00	100.32 AV			2.02 H	235	67.84	32.48
3	4874.00	50.48 PK	74.00	-23.52	1.00 H	128	11.80	38.67
4	4874.00	45.06 AV	54.00	-8.94	1.00 H	128	6.38	38.67
ANTENNA POLARITY & TEST DISTANCE: VERTICAL AT 3 M								
NO.	FREQ. (MHz)	EMISSION LEVEL (dBuV/m)	LIMIT (dBuV/m)	MARGIN (dB)	ANTENNA HEIGHT (m)	TABLE ANGLE (Degree)	RAW VALUE (dBuV)	CORRECTION FACTOR (dB/m)
1	*2437.00	110.08 PK			1.00 V	251	77.60	32.48
2	*2437.00	105.02 AV			1.00 V	251	72.54	32.48
3	4874.00	57.43 PK	74.00	-16.57	1.21 V	87	18.75	38.67
4	4874.00	52.82 AV	54.00	-1.18	1.21 V	87	14.15	38.67

- REMARKS:**
1. Emission level (dBuV/m) = Raw Value (dBuV) + Correction Factor (dB/m).
  2. Correction Factor (dB/m) = Antenna Factor (dB/m) + Cable Factor (dB).
  3. The other emission levels were very low against the limit.
  4. Margin value = Emission level – Limit value.
  5. “ \* “: Fundamental frequency.



A D T

EUT TEST CONDITION		MEASUREMENT DETAIL	
CHANNEL	Channel 11	FREQUENCY RANGE	1 ~ 25GHz
INPUT POWER	120Vac, 60 Hz	DETECTOR FUNCTION	Peak (PK) Average (AV)
ENVIRONMENTAL CONDITIONS	25deg. C, 68%RH 1000 hPa	TESTED BY	Sun Lin
TEST MODE	A		

ANTENNA POLARITY & TEST DISTANCE: HORIZONTAL AT 3 M								
NO.	FREQ. (MHz)	EMISSION LEVEL (dBuV/m)	LIMIT (dBuV/m)	MARGIN (dB)	ANTENNA HEIGHT (m)	TABLE ANGLE (Degree)	RAW VALUE (dBuV)	CORRECTION FACTOR (dB/m)
1	*2462.00	105.02 PK			1.98 H	232	72.44	32.58
2	*2462.00	100.01 AV			1.98 H	232	67.43	32.58
3	2483.50	53.21 PK	74.00	-20.79	1.87 H	230	20.55	32.66
4	2483.50	43.58 AV	54.00	-10.42	1.87 H	230	10.92	32.66
5	4924.00	51.22 PK	74.00	-22.78	1.00 H	163	12.43	38.79
6	4924.00	43.49 AV	54.00	-10.51	1.00 H	163	4.70	38.79
ANTENNA POLARITY & TEST DISTANCE: VERTICAL AT 3 M								
NO.	FREQ. (MHz)	EMISSION LEVEL (dBuV/m)	LIMIT (dBuV/m)	MARGIN (dB)	ANTENNA HEIGHT (m)	TABLE ANGLE (Degree)	RAW VALUE (dBuV)	CORRECTION FACTOR (dB/m)
1	*2462.00	110.01 PK			1.00 V	243	77.43	32.58
2	*2462.00	105.02 AV			1.00 V	243	72.44	32.58
3	2483.50	58.69 PK	74.00	-15.31	1.03 V	252	26.03	32.66
4	2483.50	46.29 AV	54.00	-7.71	1.03 V	252	13.63	32.66
5	4924.00	56.44 PK	74.00	-17.56	1.07 V	118	17.65	38.79
6	4924.00	52.97 AV	54.00	-1.03	1.07 V	118	14.18	38.79

- REMARKS:**
1. Emission level (dBuV/m) = Raw Value (dBuV) + Correction Factor (dB/m).
  2. Correction Factor (dB/m) = Antenna Factor (dB/m) + Cable Factor (dB).
  3. The other emission levels were very low against the limit.
  4. Margin value = Emission level – Limit value.
  5. “ \* ”: Fundamental frequency.



A D T

### 802.11g OFDM MODULATION

EUT TEST CONDITION		MEASUREMENT DETAIL	
CHANNEL	Channel 1	FREQUENCY RANGE	1 ~ 25GHz
INPUT POWER	120Vac, 60 Hz	DETECTOR FUNCTION	Peak (PK) Average (AV)
ENVIRONMENTAL CONDITIONS	25deg. C, 68%RH 1000 hPa	TESTED BY	Sun Lin
TEST MODE	A		

ANTENNA POLARITY & TEST DISTANCE: HORIZONTAL AT 3 M								
NO.	FREQ. (MHz)	EMISSION LEVEL (dBuV/m)	LIMIT (dBuV/m)	MARGIN (dB)	ANTENNA HEIGHT (m)	TABLE ANGLE (Degree)	RAW VALUE (dBuV)	CORRECTION FACTOR (dB/m)
1	2390.00	60.89 PK	74.00	-13.11	1.05 H	268	28.60	32.29
2	2390.00	46.06 AV	54.00	-7.94	1.05 H	268	13.77	32.29
3	*2412.00	107.19 PK			1.76 H	83	74.81	32.38
4	*2412.00	97.05 AV			1.76 H	83	64.67	32.38
5	4824.00	50.03 PK	74.00	-23.97	1.08 H	206	11.47	38.56
6	4824.00	37.28 AV	54.00	-16.72	1.08 H	206	-1.28	38.56
ANTENNA POLARITY & TEST DISTANCE: VERTICAL AT 3 M								
NO.	FREQ. (MHz)	EMISSION LEVEL (dBuV/m)	LIMIT (dBuV/m)	MARGIN (dB)	ANTENNA HEIGHT (m)	TABLE ANGLE (Degree)	RAW VALUE (dBuV)	CORRECTION FACTOR (dB/m)
1	2390.00	59.19 PK	74.00	-14.81	1.33 V	337	26.90	32.29
2	2390.00	45.94 AV	54.00	-8.06	1.33 V	337	13.65	32.29
3	*2412.00	103.86 PK			1.29 V	337	71.48	32.38
4	*2412.00	93.82 AV			1.29 V	337	61.44	32.38
5	4824.00	49.57 PK	74.00	-24.43	1.40 V	45	11.00	38.56
6	4824.00	36.59 AV	54.00	-17.41	1.40 V	45	-1.98	38.56

- REMARKS:**
1. Emission level (dBuV/m) = Raw Value (dBuV) + Correction Factor (dB/m).
  2. Correction Factor (dB/m) = Antenna Factor (dB/m) + Cable Factor (dB).
  3. The other emission levels were very low against the limit.
  4. Margin value = Emission level – Limit value.
  5. “ \* “: Fundamental frequency.



A D T

EUT TEST CONDITION		MEASUREMENT DETAIL	
CHANNEL	Channel 6	FREQUENCY RANGE	1 ~ 25GHz
INPUT POWER	120Vac, 60 Hz	DETECTOR FUNCTION	Peak (PK) Average (AV)
ENVIRONMENTAL CONDITIONS	25deg. C, 68%RH 1000 hPa	TESTED BY	Sun Lin
TEST MODE	A		

ANTENNA POLARITY & TEST DISTANCE: HORIZONTAL AT 3 M								
NO.	FREQ. (MHz)	EMISSION LEVEL (dBuV/m)	LIMIT (dBuV/m)	MARGIN (dB)	ANTENNA HEIGHT (m)	TABLE ANGLE (Degree)	RAW VALUE (dBuV)	CORRECTION FACTOR (dB/m)
1	*2437.00	108.08 PK			1.78 H	83	75.60	32.48
2	*2437.00	98.01 AV			1.78 H	83	65.53	32.48
3	4874.00	49.23 PK	74.00	-24.77	1.00 H	209	10.56	38.67
4	4874.00	38.09 AV	54.00	-15.91	1.00 H	209	-0.58	38.67
ANTENNA POLARITY & TEST DISTANCE: VERTICAL AT 3 M								
NO.	FREQ. (MHz)	EMISSION LEVEL (dBuV/m)	LIMIT (dBuV/m)	MARGIN (dB)	ANTENNA HEIGHT (m)	TABLE ANGLE (Degree)	RAW VALUE (dBuV)	CORRECTION FACTOR (dB/m)
1	*2437.00	105.07 PK			1.51 V	66	72.59	32.48
2	*2437.00	95.02 AV			1.51 V	66	62.54	32.48
3	4874.00	48.63 PK	74.00	-25.37	1.00 V	165	9.95	38.67
4	4874.00	37.12 AV	54.00	-16.88	1.00 V	165	-1.56	38.67

- REMARKS:**
1. Emission level (dBuV/m) = Raw Value (dBuV) + Correction Factor (dB/m).
  2. Correction Factor (dB/m) = Antenna Factor (dB/m) + Cable Factor (dB).
  3. The other emission levels were very low against the limit.
  4. Margin value = Emission level – Limit value.
  5. “ \* “: Fundamental frequency.



A D T

EUT TEST CONDITION		MEASUREMENT DETAIL	
CHANNEL	Channel 11	FREQUENCY RANGE	1 ~ 25GHz
INPUT POWER	120Vac, 60 Hz	DETECTOR FUNCTION	Peak (PK) Average (AV)
ENVIRONMENTAL CONDITIONS	25deg. C, 68%RH 1000 hPa	TESTED BY	Sun Lin
TEST MODE	A		

ANTENNA POLARITY & TEST DISTANCE: HORIZONTAL AT 3 M								
NO.	FREQ. (MHz)	EMISSION LEVEL (dBuV/m)	LIMIT (dBuV/m)	MARGIN (dB)	ANTENNA HEIGHT (m)	TABLE ANGLE (Degree)	RAW VALUE (dBuV)	CORRECTION FACTOR (dB/m)
1	*2462.00	107.08 PK			1.76 H	84	74.50	32.58
2	*2462.00	96.91 AV			1.76 H	84	64.33	32.58
3	2483.50	58.69 PK	74.00	-15.31	1.62 H	90	26.03	32.66
4	2483.50	47.58 AV	54.00	-6.42	1.62 H	90	14.92	32.66
5	4924.00	45.98 PK	74.00	-28.02	1.72 H	118	7.19	38.79
6	4924.00	33.21 AV	54.00	-20.79	1.72 H	118	-5.58	38.79
ANTENNA POLARITY & TEST DISTANCE: VERTICAL AT 3 M								
NO.	FREQ. (MHz)	EMISSION LEVEL (dBuV/m)	LIMIT (dBuV/m)	MARGIN (dB)	ANTENNA HEIGHT (m)	TABLE ANGLE (Degree)	RAW VALUE (dBuV)	CORRECTION FACTOR (dB/m)
1	*2462.00	103.75 PK			1.81 V	56	71.17	32.58
2	*2462.00	93.46 AV			1.81 V	56	60.88	32.58
3	2483.50	57.75 PK	74.00	-16.25	1.80 V	50	25.09	32.66
4	2483.50	46.28 AV	54.00	-7.72	1.80 V	50	13.62	32.66
5	4924.00	47.17 PK	74.00	-26.83	1.52 V	10	8.38	38.79
6	4924.00	36.09 AV	54.00	-17.91	1.52 V	10	-2.70	38.79

- REMARKS:**
1. Emission level (dBuV/m) = Raw Value (dBuV) + Correction Factor (dB/m).
  2. Correction Factor (dB/m) = Antenna Factor (dB/m) + Cable Factor (dB).
  3. The other emission levels were very low against the limit.
  4. Margin value = Emission level – Limit value.
  5. “ \* ”: Fundamental frequency.



A D T

**DRAFT 802.11n (20MHz) OFDM MODULATION**

EUT TEST CONDITION		MEASUREMENT DETAIL	
CHANNEL	Channel 1	FREQUENCY RANGE	1 ~ 25GHz
INPUT POWER	120Vac, 60 Hz	DETECTOR FUNCTION	Peak (PK) Average (AV)
ENVIRONMENTAL CONDITIONS	25deg. C, 68%RH 1000 hPa	TESTED BY	Sun Lin
TEST MODE	A		

ANTENNA POLARITY & TEST DISTANCE: HORIZONTAL AT 3 M								
NO.	FREQ. (MHz)	EMISSION LEVEL (dBuV/m)	LIMIT (dBuV/m)	MARGIN (dB)	ANTENNA HEIGHT (m)	TABLE ANGLE (Degree)	RAW VALUE (dBuV)	CORRECTION FACTOR (dB/m)
1	2334.00	53.21 PK	74.00	-20.79	1.09 H	143	21.14	32.07
2	2334.00	43.18 AV	54.00	-10.82	1.09 H	143	11.11	32.07
3	*2412.00	102.68 PK			1.00 H	288	70.30	32.38
4	*2412.00	92.56 AV			1.00 H	288	60.18	32.38
5	4824.00	48.08 PK	74.00	-25.92	1.16 H	150	9.51	38.56
6	4824.00	36.01 AV	54.00	-17.99	1.16 H	150	-2.55	38.56

ANTENNA POLARITY & TEST DISTANCE: VERTICAL AT 3 M								
NO.	FREQ. (MHz)	EMISSION LEVEL (dBuV/m)	LIMIT (dBuV/m)	MARGIN (dB)	ANTENNA HEIGHT (m)	TABLE ANGLE (Degree)	RAW VALUE (dBuV)	CORRECTION FACTOR (dB/m)
1	2334.00	56.98 PK	74.00	-17.02	1.00 V	307	24.91	32.07
2	2334.00	46.32 AV	54.00	-7.68	1.00 V	307	14.25	32.07
3	*2412.00	107.34 PK			1.00 V	256	74.96	32.38
4	*2412.00	96.62 AV			1.00 V	256	64.24	32.38
5	4824.00	48.77 PK	74.00	-25.23	1.30 V	53	10.20	38.56
6	4824.00	36.73 AV	54.00	-17.27	1.30 V	53	-1.84	38.56

- REMARKS:**
1. Emission level (dBuV/m) = Raw Value (dBuV) + Correction Factor (dB/m).
  2. Correction Factor (dB/m) = Antenna Factor (dB/m) + Cable Factor (dB).
  3. The other emission levels were very low against the limit.
  4. Margin value = Emission level – Limit value.
  5. “ \* “: Fundamental frequency.



A D T

EUT TEST CONDITION		MEASUREMENT DETAIL	
CHANNEL	Channel 6	FREQUENCY RANGE	1 ~ 25GHz
INPUT POWER	120Vac, 60 Hz	DETECTOR FUNCTION	Peak (PK) Average (AV)
ENVIRONMENTAL CONDITIONS	25deg. C, 68%RH 1000 hPa	TESTED BY	Sun Lin
TEST MODE	A		

ANTENNA POLARITY & TEST DISTANCE: HORIZONTAL AT 3 M								
NO.	FREQ. (MHz)	EMISSION LEVEL (dBuV/m)	LIMIT (dBuV/m)	MARGIN (dB)	ANTENNA HEIGHT (m)	TABLE ANGLE (Degree)	RAW VALUE (dBuV)	CORRECTION FACTOR (dB/m)
1	*2437.00	102.89 PK			1.14 H	292	70.41	32.48
2	*2437.00	92.23 AV			1.14 H	292	59.75	32.48
3	4874.00	48.32 PK	74.00	-25.68	1.27 H	300	9.65	38.67
4	4874.00	35.14 AV	54.00	-18.86	1.27 H	300	-3.53	38.67
ANTENNA POLARITY & TEST DISTANCE: VERTICAL AT 3 M								
NO.	FREQ. (MHz)	EMISSION LEVEL (dBuV/m)	LIMIT (dBuV/m)	MARGIN (dB)	ANTENNA HEIGHT (m)	TABLE ANGLE (Degree)	RAW VALUE (dBuV)	CORRECTION FACTOR (dB/m)
1	*2437.00	106.76 PK			1.00 V	253	74.28	32.48
2	*2437.00	96.08 AV			1.00 V	253	63.60	32.48
3	4874.00	50.18 PK	74.00	-23.82	1.29 V	101	11.50	38.67
4	4874.00	37.63 AV	54.00	-16.37	1.29 V	101	-1.05	38.67

- REMARKS:**
1. Emission level (dBuV/m) = Raw Value (dBuV) + Correction Factor (dB/m).
  2. Correction Factor (dB/m) = Antenna Factor (dB/m) + Cable Factor (dB).
  3. The other emission levels were very low against the limit.
  4. Margin value = Emission level – Limit value.
  5. “ \* “: Fundamental frequency.



A D T

EUT TEST CONDITION		MEASUREMENT DETAIL	
CHANNEL	Channel 11	FREQUENCY RANGE	1 ~ 25GHz
INPUT POWER	120Vac, 60 Hz	DETECTOR FUNCTION	Peak (PK) Average (AV)
ENVIRONMENTAL CONDITIONS	25deg. C, 68%RH 1000 hPa	TESTED BY	Sun Lin
TEST MODE	A		

ANTENNA POLARITY & TEST DISTANCE: HORIZONTAL AT 3 M								
NO.	FREQ. (MHz)	EMISSION LEVEL (dBuV/m)	LIMIT (dBuV/m)	MARGIN (dB)	ANTENNA HEIGHT (m)	TABLE ANGLE (Degree)	RAW VALUE (dBuV)	CORRECTION FACTOR (dB/m)
1	*2462.00	102.87 PK			1.13 H	291	70.29	32.58
2	*2462.00	92.02 AV			1.13 H	291	59.44	32.58
3	2483.50	57.90 PK	74.00	-16.10	1.28 H	303	25.24	32.66
4	2483.50	45.91 AV	54.00	-8.09	1.28 H	303	13.25	32.66
5	4924.00	50.84 PK	74.00	-23.16	1.08 H	160	12.05	38.79
6	4924.00	38.56 AV	54.00	-15.44	1.08 H	160	-0.23	38.79
ANTENNA POLARITY & TEST DISTANCE: VERTICAL AT 3 M								
NO.	FREQ. (MHz)	EMISSION LEVEL (dBuV/m)	LIMIT (dBuV/m)	MARGIN (dB)	ANTENNA HEIGHT (m)	TABLE ANGLE (Degree)	RAW VALUE (dBuV)	CORRECTION FACTOR (dB/m)
1	*2462.00	106.62 PK			1.00 V	248	74.04	32.58
2	*2462.00	96.06 AV			1.00 V	248	63.48	32.58
3	2483.50	60.12 PK	74.00	-13.88	1.18 V	233	27.46	32.66
4	2483.50	47.58 AV	54.00	-6.42	1.18 V	233	14.92	32.66
5	4924.00	53.12 PK	74.00	-20.88	1.01 V	132	14.33	38.79
6	4924.00	41.07 AV	54.00	-12.93	1.01 V	132	2.28	38.79

- REMARKS:**
1. Emission level (dBuV/m) = Raw Value (dBuV) + Correction Factor (dB/m).
  2. Correction Factor (dB/m) = Antenna Factor (dB/m) + Cable Factor (dB).
  3. The other emission levels were very low against the limit.
  4. Margin value = Emission level – Limit value.
  5. “ \* ”: Fundamental frequency.





A D T

**DRAFT 802.11n (40MHz) OFDM MODULATION**

EUT TEST CONDITION		MEASUREMENT DETAIL	
CHANNEL	Channel 1	FREQUENCY RANGE	1 ~ 25GHz
INPUT POWER	120Vac, 60 Hz	DETECTOR FUNCTION	Peak (PK) Average (AV)
ENVIRONMENTAL CONDITIONS	25deg. C, 68%RH 1000 hPa	TESTED BY	Sun Lin
TEST MODE	A		

ANTENNA POLARITY & TEST DISTANCE: HORIZONTAL AT 3 M								
NO.	FREQ. (MHz)	EMISSION LEVEL (dBuV/m)	LIMIT (dBuV/m)	MARGIN (dB)	ANTENNA HEIGHT (m)	TABLE ANGLE (Degree)	RAW VALUE (dBuV)	CORRECTION FACTOR (dB/m)
1	2390.00	58.00 PK	74.00	-16.00	1.24 H	233	25.71	32.29
2	2390.00	46.17 AV	54.00	-7.83	1.24 H	233	13.88	32.29
3	*2422.00	99.30 PK			1.44 H	225	66.88	32.42
4	*2422.00	89.02 AV			1.44 H	225	56.60	32.42
5	4844.00	48.01 PK	74.00	-25.99	1.11 H	207	9.40	38.61
6	4844.00	37.28 AV	54.00	-16.72	1.11 H	207	-1.33	38.61
ANTENNA POLARITY & TEST DISTANCE: VERTICAL AT 3 M								
NO.	FREQ. (MHz)	EMISSION LEVEL (dBuV/m)	LIMIT (dBuV/m)	MARGIN (dB)	ANTENNA HEIGHT (m)	TABLE ANGLE (Degree)	RAW VALUE (dBuV)	CORRECTION FACTOR (dB/m)
1	2390.00	60.18 PK	74.00	-13.82	1.07 V	118	27.89	32.29
2	2390.00	48.17 AV	54.00	-5.83	1.07 V	118	15.88	32.29
3	*2422.00	104.96 PK			1.00 V	253	72.54	32.42
4	*2422.00	94.33 AV			1.00 V	253	61.91	32.42
5	4844.00	51.79 PK	74.00	-22.21	1.21 V	243	13.18	38.61
6	4844.00	39.95 AV	54.00	-14.05	1.21 V	243	1.34	38.61

- REMARKS:**
1. Emission level (dBuV/m) = Raw Value (dBuV) + Correction Factor (dB/m).
  2. Correction Factor (dB/m) = Antenna Factor (dB/m) + Cable Factor (dB).
  3. The other emission levels were very low against the limit.
  4. Margin value = Emission level – Limit value.
  5. “ \* “: Fundamental frequency.



A D T

EUT TEST CONDITION		MEASUREMENT DETAIL	
CHANNEL	Channel 4	FREQUENCY RANGE	1 ~ 25GHz
INPUT POWER	120Vac, 60 Hz	DETECTOR FUNCTION	Peak (PK) Average (AV)
ENVIRONMENTAL CONDITIONS	25deg. C, 68%RH 1000 hPa	TESTED BY	Sun Lin
TEST MODE	A		

ANTENNA POLARITY & TEST DISTANCE: HORIZONTAL AT 3 M								
NO.	FREQ. (MHz)	EMISSION LEVEL (dBuV/m)	LIMIT (dBuV/m)	MARGIN (dB)	ANTENNA HEIGHT (m)	TABLE ANGLE (Degree)	RAW VALUE (dBuV)	CORRECTION FACTOR (dB/m)
1	*2437.00	99.46 PK			1.00 H	299	66.98	32.48
2	*2437.00	89.26 AV			1.00 H	299	56.78	32.48
3	4874.00	48.96 PK	74.00	-25.04	1.03 H	271	10.29	38.67
4	4874.00	38.04 AV	54.00	-15.96	1.03 H	271	-0.63	38.67
ANTENNA POLARITY & TEST DISTANCE: VERTICAL AT 3 M								
NO.	FREQ. (MHz)	EMISSION LEVEL (dBuV/m)	LIMIT (dBuV/m)	MARGIN (dB)	ANTENNA HEIGHT (m)	TABLE ANGLE (Degree)	RAW VALUE (dBuV)	CORRECTION FACTOR (dB/m)
1	*2437.00	104.99 PK			1.00 V	267	72.51	32.48
2	*2437.00	94.85 AV			1.00 V	267	62.37	32.48
3	4874.00	51.93 PK	74.00	-22.07	1.23 V	317	13.26	38.67
4	4874.00	40.08 AV	54.00	-13.92	1.23 V	317	1.41	38.67

- REMARKS:**
1. Emission level (dBuV/m) = Raw Value (dBuV) + Correction Factor (dB/m).
  2. Correction Factor (dB/m) = Antenna Factor (dB/m) + Cable Factor (dB).
  3. The other emission levels were very low against the limit.
  4. Margin value = Emission level – Limit value.
  5. “ \* “: Fundamental frequency.



A D T

EUT TEST CONDITION		MEASUREMENT DETAIL	
CHANNEL	Channel 7	FREQUENCY RANGE	1 ~ 25GHz
INPUT POWER	120Vac, 60 Hz	DETECTOR FUNCTION	Peak (PK) Average (AV)
ENVIRONMENTAL CONDITIONS	25deg. C, 68%RH 1000 hPa	TESTED BY	Sun Lin
TEST MODE	A		

ANTENNA POLARITY & TEST DISTANCE: HORIZONTAL AT 3 M								
NO.	FREQ. (MHz)	EMISSION LEVEL (dBuV/m)	LIMIT (dBuV/m)	MARGIN (dB)	ANTENNA HEIGHT (m)	TABLE ANGLE (Degree)	RAW VALUE (dBuV)	CORRECTION FACTOR (dB/m)
1	*2452.00	99.08 PK			1.00 H	294	66.54	32.54
2	*2452.00	89.00 AV			1.00 H	294	56.46	32.54
3	2483.50	56.31 PK	74.00	-17.69	1.12 H	304	23.65	32.66
4	2483.50	45.32 AV	54.00	-8.68	1.12 H	304	12.66	32.66
5	4904.00	50.03 PK	74.00	-23.97	1.25 H	30	11.29	38.74
6	4904.00	34.23 AV	54.00	-19.77	1.25 H	30	-4.51	38.74
ANTENNA POLARITY & TEST DISTANCE: VERTICAL AT 3 M								
NO.	FREQ. (MHz)	EMISSION LEVEL (dBuV/m)	LIMIT (dBuV/m)	MARGIN (dB)	ANTENNA HEIGHT (m)	TABLE ANGLE (Degree)	RAW VALUE (dBuV)	CORRECTION FACTOR (dB/m)
1	*2452.00	104.06 PK			1.79 V	50	71.52	32.54
2	*2452.00	94.07 AV			1.79 V	50	61.53	32.54
3	2483.50	58.02 PK	74.00	-15.98	1.04 V	70	25.36	32.66
4	2483.50	47.36 AV	54.00	-6.64	1.04 V	70	14.70	32.66
5	4904.00	52.25 PK	74.00	-21.75	1.05 V	231	13.51	38.74
6	4904.00	38.01 AV	54.00	-15.99	1.05 V	231	-0.73	38.74

- REMARKS:**
1. Emission level (dBuV/m) = Raw Value (dBuV) + Correction Factor (dB/m).
  2. Correction Factor (dB/m) = Antenna Factor (dB/m) + Cable Factor (dB).
  3. The other emission levels were very low against the limit.
  4. Margin value = Emission level – Limit value.
  5. “ \* ”: Fundamental frequency.



A D T

**BELOW 1GHz WORST-CASE DATA : DRAFT 802.11n (20MHz) OFDM MODULATION**

EUT TEST CONDITION		MEASUREMENT DETAIL	
CHANNEL	Channel 1	FREQUENCY RANGE	Below 1000MHz
INPUT POWER	120Vac, 60 Hz	DETECTOR FUNCTION	Quasi-Peak
ENVIRONMENTAL CONDITIONS	26deg. C, 62%RH 999 hPa	TESTED BY	Sun Lin
TEST MODE	A		

ANTENNA POLARITY & TEST DISTANCE: HORIZONTAL AT 3 M								
NO.	FREQ. (MHz)	EMISSION LEVEL (dBuV/m)	LIMIT (dBuV/m)	MARGIN (dB)	ANTENNA HEIGHT (m)	TABLE ANGLE (Degree)	RAW VALUE (dBuV)	CORRECTION FACTOR (dB/m)
1	127.11	37.01 QP	43.50	-6.49	1.25 H	76	24.77	12.24
2	249.60	39.73 QP	46.00	-6.27	1.25 H	73	26.54	13.18
3	297.00	44.85 QP	46.00	-1.15	1.00 H	69	29.45	15.40
4	593.74	36.41 QP	46.00	-9.59	1.50 H	139	13.43	22.98
5	743.45	38.49 QP	46.00	-7.51	1.00 H	10	13.15	25.33
6	825.11	43.48 QP	46.00	-2.52	1.00 H	112	16.61	26.87
ANTENNA POLARITY & TEST DISTANCE: VERTICAL AT 3 M								
NO.	FREQ. (MHz)	EMISSION LEVEL (dBuV/m)	LIMIT (dBuV/m)	MARGIN (dB)	ANTENNA HEIGHT (m)	TABLE ANGLE (Degree)	RAW VALUE (dBuV)	CORRECTION FACTOR (dB/m)
1	41.57	35.43 QP	40.00	-4.57	1.25 V	10	21.51	13.92
2	70.73	34.32 QP	40.00	-5.68	1.00 V	196	22.03	12.30
3	296.27	39.30 QP	46.00	-6.70	1.25 V	52	23.94	15.36
4	445.98	36.18 QP	46.00	-9.82	1.25 V	253	16.87	19.31
5	679.29	38.13 QP	46.00	-7.87	1.00 V	103	13.96	24.17
6	891.22	42.61 QP	46.00	-3.39	1.25 V	115	14.54	28.07

- REMARKS:**
1. Emission level (dBuV/m) = Raw Value (dBuV) + Correction Factor (dB/m).
  2. Correction Factor (dB/m) = Antenna Factor (dB/m) + Cable Factor (dB).
  3. The other emission levels were very low against the limit.
  4. Margin value = Emission level – Limit value.



A D T

EUT TEST CONDITION		MEASUREMENT DETAIL	
CHANNEL	Channel 1	FREQUENCY RANGE	Below 1000MHz
INPUT POWER	120Vac, 60 Hz	DETECTOR FUNCTION	Quasi-Peak
ENVIRONMENTAL CONDITIONS	26deg. C, 62%RH 999 hPa	TESTED BY	Sun Lin
TEST MODE	B		

ANTENNA POLARITY & TEST DISTANCE: HORIZONTAL AT 3 M								
NO.	FREQ. (MHz)	EMISSION LEVEL (dBuV/m)	LIMIT (dBuV/m)	MARGIN (dB)	ANTENNA HEIGHT (m)	TABLE ANGLE (Degree)	RAW VALUE (dBuV)	CORRECTION FACTOR (dB/m)
1	249.60	40.69 QP	46.00	-5.31	1.00 H	76	27.50	13.18
2	296.27	44.88 QP	46.00	-1.12	1.00 H	52	29.52	15.36
3	445.98	40.19 QP	46.00	-5.81	1.00 H	31	20.88	19.31
4	657.91	37.77 QP	46.00	-8.23	1.50 H	82	13.88	23.89
5	722.07	38.13 QP	46.00	-7.87	1.00 H	88	13.23	24.90
6	891.22	36.78 QP	46.00	-9.22	1.00 H	31	8.71	28.07
ANTENNA POLARITY & TEST DISTANCE: VERTICAL AT 3 M								
NO.	FREQ. (MHz)	EMISSION LEVEL (dBuV/m)	LIMIT (dBuV/m)	MARGIN (dB)	ANTENNA HEIGHT (m)	TABLE ANGLE (Degree)	RAW VALUE (dBuV)	CORRECTION FACTOR (dB/m)
1	30.00	36.39 QP	40.00	-3.61	1.00 V	55	23.58	12.81
2	296.27	40.28 QP	46.00	-5.72	1.50 V	97	24.92	15.36
3	339.04	43.50 QP	46.00	-2.50	2.00 V	55	27.02	16.49
4	445.98	38.26 QP	46.00	-7.74	1.50 V	271	18.94	19.31
5	500.42	36.14 QP	46.00	-9.86	2.00 V	28	15.39	20.75
6	891.22	42.10 QP	46.00	-3.90	1.25 V	106	14.04	28.07

- REMARKS:**
1. Emission level (dBuV/m) = Raw Value (dBuV) + Correction Factor (dB/m).
  2. Correction Factor (dB/m) = Antenna Factor (dB/m) + Cable Factor (dB).
  3. The other emission levels were very low against the limit.
  4. Margin value = Emission level – Limit value.



A D T

## 4.2 CONDUCTED EMISSION MEASUREMENT

### 4.2.1 LIMITS OF CONDUCTED EMISSION MEASUREMENT

FREQUENCY OF EMISSION (MHz)	CONDUCTED LIMIT (dB $\mu$ V)	
	Quasi-peak	Average
0.15 ~ 0.5	66 to 56	56 to 46
0.5 ~ 5	56	46
5 ~ 30	60	50

- NOTE:** 1. The lower limit shall apply at the transition frequencies.  
2. The limit decreases in line with the logarithm of the frequency in the range of 0.15 to 0.50MHz.  
3. All emanations from a class A/B digital device or system, including any network of conductors and apparatus connected thereto, shall not exceed the level of field strengths specified above.

### 4.2.2 TEST INSTRUMENTS

DESCRIPTION & MANUFACTURER	MODEL NO.	SERIAL NO.	DATE OF CALIBRATION	DUE DATE OF CALIBRATION
Test Receiver ROHDE & SCHWARZ	ESCS30	100291	Nov. 19, 2008	Nov. 18, 2009
RF signal cable Woken	5D-FB	Cable-HYC01-01	Dec. 31, 2008	Dec. 30, 2009
LISN SCHWARZBECK	NNBL 8226-2	8226-142	Jun. 03, 2009	Jun. 02, 2010
LISN ROHDE & SCHWARZ	ESH2-Z5	100104	Dec. 04, 2008	Dec. 03, 2009
Software ADT	ADT_Cond_ V7.3.7	NA	NA	NA

- NOTE:** 1. The calibration interval of the above test instruments is 12 months and the calibrations are traceable to NML/ROC and NIST/USA.  
2. The test was performed in HwaYa Shielded Room 1.  
3. The VCCI Site Registration No. is C-2040.



A D T

#### 4.2.3 TEST PROCEDURES

- a. The EUT was placed 0.4 meters from the conducting wall of the shielded room with EUT being connected to the power mains through a line impedance stabilization network (LISN). Other support units were connected to the power mains through another LISN. The two LISNs provide 50 ohm/ 50uH of coupling impedance for the measuring instrument.
- b. Both lines of the power mains connected to the EUT were checked for maximum conducted interference.
- c. The frequency range from 150kHz to 30MHz was searched. Emission levels under (Limit - 20dB) was not recorded.

**NOTE:** All modes of operation were investigated and the worst-case emissions are reported.

#### 4.2.4 DEVIATION FROM TEST STANDARD

No deviation.

#### 4.2.5 TEST SETUP

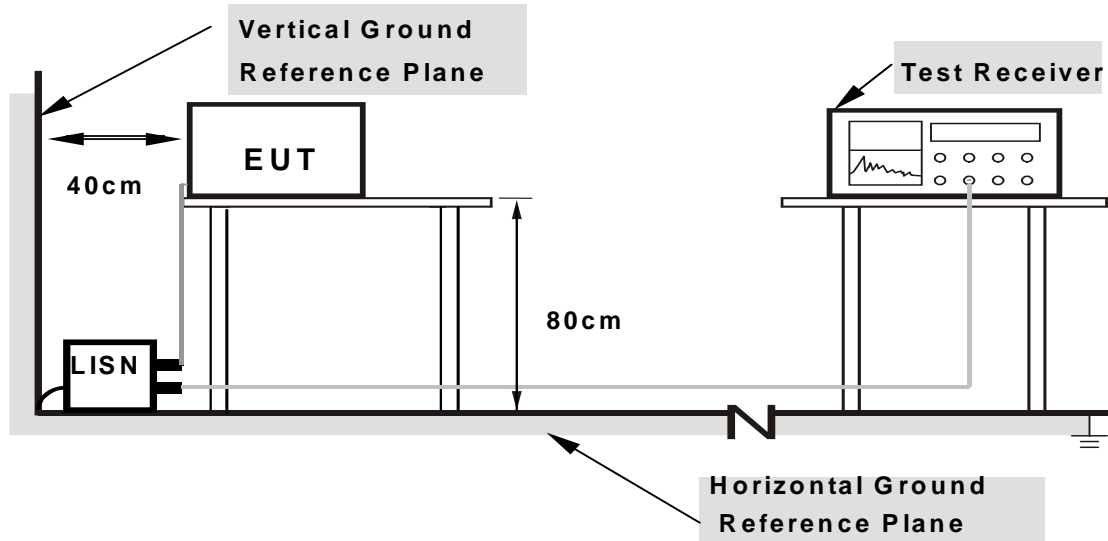

- Note:**
1. Support units were connected to second LISN.
  2. Both of LISNs (AMN) are 80 cm from EUT and at least 80 from other units and other metal planes

For the actual test configuration, please refer to the attached file (Test Setup Photo).

#### 4.2.6 EUT OPERATING CONDITIONS

Same as 4.1.6.





A D T

#### 4.2.7 TEST RESULTS

##### CONDUCTED WORST-CASE DATA : DRAFT 802.11n (20MHz) OFDM MODULATION

EUT TEST CONDITION		MEASUREMENT DETAIL	
CHANNEL	Channel 1	PHASE	Line 1
MODULATION TYPE	BPSK	INPUT POWER	120Vac, 60Hz
TRANSFER RATE	7.2Mbps	6dB BANDWIDTH	9kHz
ENVIRONMENTAL CONDITIONS	20deg. C, 60%RH, 1011hPa	TESTED BY	Match Tsui
TEST MODE	A		

No	Freq. [MHz]	Corr. Factor (dB)	Reading Value		Emission Level		Limit		Margin	
			[dB (uV)]		[dB (uV)]		[dB (uV)]		(dB)	
			Q.P.	AV.	Q.P.	AV.	Q.P.	AV.	Q.P.	AV.
1	0.150	0.13	41.18	-	41.31	-	66.00	56.00	-24.69	-
2	0.197	0.13	36.77	-	36.90	-	63.74	53.74	-26.84	-
3	0.279	0.13	30.80	-	30.93	-	60.85	50.85	-29.91	-
4	0.502	0.15	19.08	-	19.23	-	56.00	46.00	-36.77	-
5	2.352	0.25	31.37	-	31.62	-	56.00	46.00	-24.38	-
6	24.871	1.22	18.72	-	19.94	-	60.00	50.00	-40.06	-

- REMARKS:**
1. Q.P. and AV. are abbreviations of quasi-peak and average individually.
  2. "-": The Quasi-peak reading value also meets average limit and measurement with the average detector is unnecessary.
  3. The emission levels of other frequencies were very low against the limit.
  4. Margin value = Emission level - Limit value
  5. Correction factor = Insertion loss + Cable loss
  6. Emission Level = Correction Factor + Reading Value.

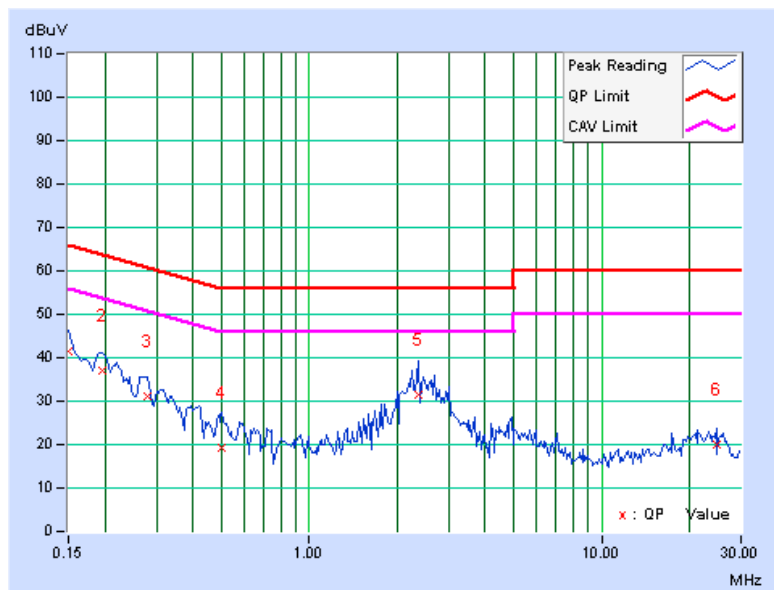

EUT TEST CONDITION		MEASUREMENT DETAIL	
CHANNEL	Channel 1	PHASE	Line 2
MODULATION TYPE	BPSK	INPUT POWER	120Vac, 60Hz
TRANSFER RATE	7.2Mbps	6dB BANDWIDTH	9kHz
ENVIRONMENTAL CONDITIONS	20deg. C, 60%RH, 1011hPa	TESTED BY	Match Tsui
TEST MODE	A		

No	Freq. [MHz]	Corr.	Reading Value		Emission Level		Limit		Margin	
		Factor	[dB (uV)]		[dB (uV)]		[dB (uV)]		(dB)	
		(dB)	Q.P.	AV.	Q.P.	AV.	Q.P.	AV.	Q.P.	AV.
1	0.150	0.14	41.99	-	42.13	-	66.00	56.00	-23.87	-
2	0.193	0.15	36.61	-	36.76	-	63.91	53.91	-27.15	-
3	0.271	0.15	31.17	-	31.32	-	61.08	51.08	-29.76	-
4	0.517	0.17	19.18	-	19.35	-	56.00	46.00	-36.65	-
5	2.516	0.29	33.22	-	33.51	-	56.00	46.00	-22.49	-
6	22.852	0.92	22.01	-	22.93	-	60.00	50.00	-37.07	-

- REMARKS:**
1. Q.P. and AV. are abbreviations of quasi-peak and average individually.
  2. "-": The Quasi-peak reading value also meets average limit and measurement with the average detector is unnecessary.
  3. The emission levels of other frequencies were very low against the limit.
  4. Margin value = Emission level - Limit value
  5. Correction factor = Insertion loss + Cable loss
  6. Emission Level = Correction Factor + Reading Value.

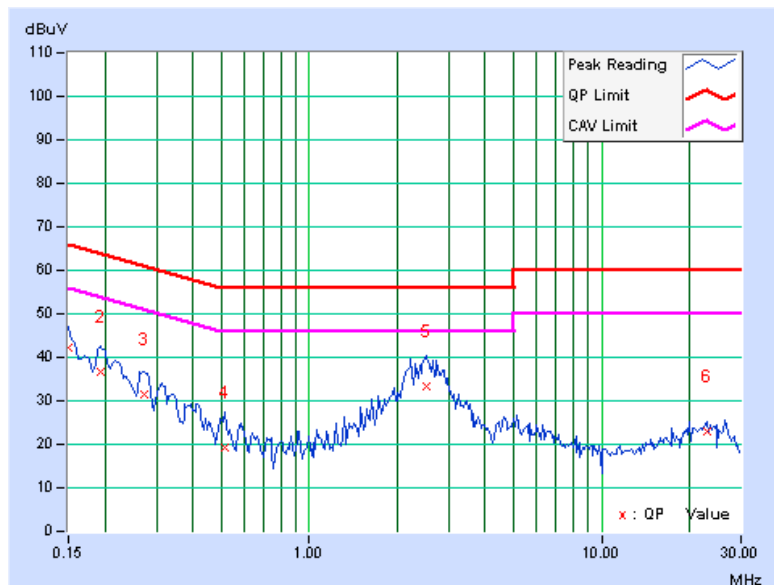

EUT TEST CONDITION		MEASUREMENT DETAIL	
CHANNEL	Channel 1	PHASE	Line 1
MODULATION TYPE	BPSK	INPUT POWER	120Vac, 60Hz
TRANSFER RATE	7.2Mbps	6dB BANDWIDTH	9kHz
ENVIRONMENTAL CONDITIONS	20deg. C, 60%RH, 1011hPa	TESTED BY	Match Tsui
TEST MODE	B		

No	Freq. [MHz]	Corr. Factor (dB)	Reading Value		Emission Level		Limit		Margin	
			[dB (uV)]		[dB (uV)]		[dB (uV)]		(dB)	
			Q.P.	AV.	Q.P.	AV.	Q.P.	AV.	Q.P.	AV.
1	0.185	0.13	48.45	-	48.58	-	64.25	54.25	-15.67	-
2	0.287	0.13	44.54	-	44.67	-	60.62	50.62	-15.94	-
3	0.455	0.14	40.73	-	40.87	-	56.79	46.79	-15.92	-
4	0.865	0.17	38.09	-	38.26	-	56.00	46.00	-17.74	-
5	4.180	0.38	33.42	-	33.80	-	56.00	46.00	-22.20	-
6	20.965	1.16	27.73	-	28.89	-	60.00	50.00	-31.11	-

- REMARKS:**
1. Q.P. and AV. are abbreviations of quasi-peak and average individually.
  2. "-": The Quasi-peak reading value also meets average limit and measurement with the average detector is unnecessary.
  3. The emission levels of other frequencies were very low against the limit.
  4. Margin value = Emission level - Limit value
  5. Correction factor = Insertion loss + Cable loss
  6. Emission Level = Correction Factor + Reading Value.

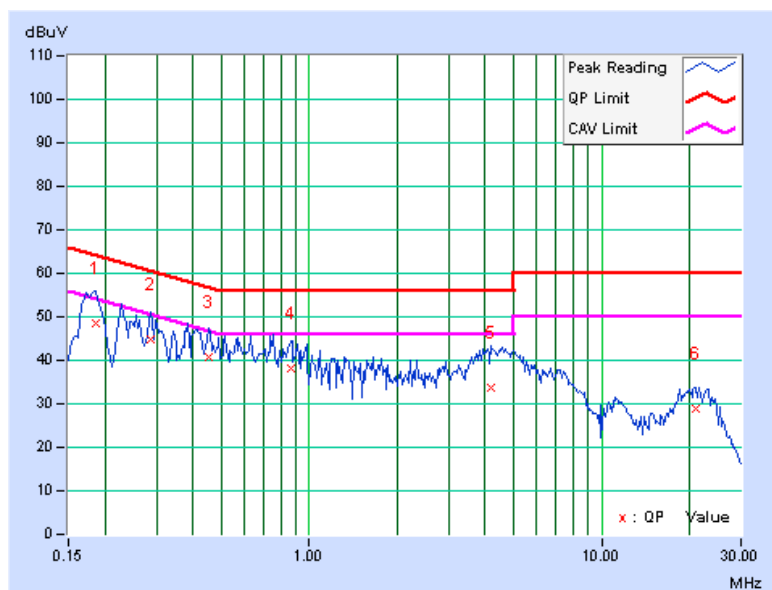

EUT TEST CONDITION		MEASUREMENT DETAIL	
CHANNEL	Channel 1	PHASE	Line 2
MODULATION TYPE	BPSK	INPUT POWER	120Vac, 60Hz
TRANSFER RATE	7.2Mbps	6dB BANDWIDTH	9kHz
ENVIRONMENTAL CONDITIONS	20deg. C, 60%RH, 1011hPa	TESTED BY	Match Tsui
TEST MODE	B		

No	Freq. [MHz]	Corr. Factor (dB)	Reading Value		Emission Level		Limit		Margin	
			[dB (uV)]		[dB (uV)]		[dB (uV)]		(dB)	
			Q.P.	AV.	Q.P.	AV.	Q.P.	AV.	Q.P.	AV.
1	0.170	0.14	48.98	-	49.12	-	64.98	54.98	-15.86	-
2	0.283	0.15	44.00	-	44.15	-	60.73	50.73	-16.58	-
3	0.517	0.17	43.82	-	43.99	-	56.00	46.00	-12.01	-
4	<b>0.749</b>	<b>0.18</b>	<b>41.82</b>	-	<b>42.00</b>	-	<b>56.00</b>	<b>46.00</b>	<b>-14.00</b>	-
5	4.288	0.40	39.44	-	39.84	-	56.00	46.00	-16.16	-
6	20.900	0.96	28.66	-	29.62	-	60.00	50.00	-30.38	-

- REMARKS:**
1. Q.P. and AV. are abbreviations of quasi-peak and average individually.
  2. "-": The Quasi-peak reading value also meets average limit and measurement with the average detector is unnecessary.
  3. The emission levels of other frequencies were very low against the limit.
  4. Margin value = Emission level - Limit value
  5. Correction factor = Insertion loss + Cable loss
  6. Emission Level = Correction Factor + Reading Value.

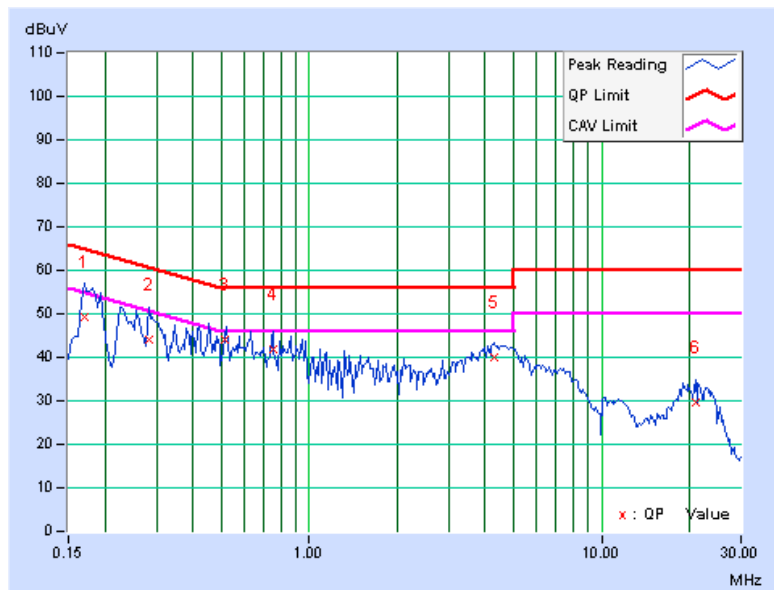



A D T

### 4.3 6dB BANDWIDTH MEASUREMENT

#### 4.3.1 LIMITS OF 6dB BANDWIDTH MEASUREMENT

The minimum of 6dB Bandwidth Measurement is 0.5 MHz.

#### 4.3.2 TEST INSTRUMENTS

DESCRIPTION & MANUFACTURER	MODEL NO.	SERIAL NO.	DATE OF CALIBRATION	DUE DATE OF CALIBRATION
R&S SPECTRUM ANALYZER	FSP40	100041	May 13, 2009	May 12, 2010

**NOTE:** The calibration interval of the above test instruments is 12 months and the calibrations are traceable to NML/ROC and NIST/USA.

#### 4.3.3 TEST PROCEDURE

The transmitter output was connected to the spectrum analyzer through an attenuator. The bandwidth of the fundamental frequency was measured by spectrum analyzer with 100kHz RBW and 300kHz VBW. The 6dB bandwidth is defined as the total spectrum the power of which is higher than peak power minus 6dB.

#### 4.3.4 DEVIATION FROM TEST STANDARD

No deviation.

#### 4.3.5 TEST SETUP

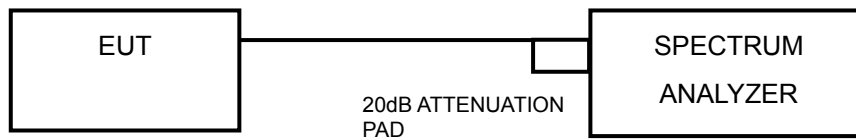

#### 4.3.6 EUT OPERATING CONDITIONS

The software provided by client to enable the EUT under transmission condition continuously at lowest, middle and highest channel frequencies individually.



A D T

### 4.3.7 TEST RESULTS

#### 802.11b DSSS MODULATION

<b>MODULATION TYPE</b>	DBPSK	<b>TRANSFER RATE</b>	1.0Mbps
<b>INPUT POWER</b>	120Vac, 60Hz	<b>ENVIRONMENTAL CONDITIONS</b>	25deg.C, 68%RH, 1009hPa
<b>TESTED BY</b>	Sun Lin		

CHANNEL	CHANNEL FREQUENCY (MHz)	6dB BANDWIDTH (MHz)	MINIMUM LIMIT (MHz)	PASS / FAIL
1	2412	10.10	0.5	PASS
6	2437	10.13	0.5	PASS
11	2462	10.13	0.5	PASS

#### CH 1

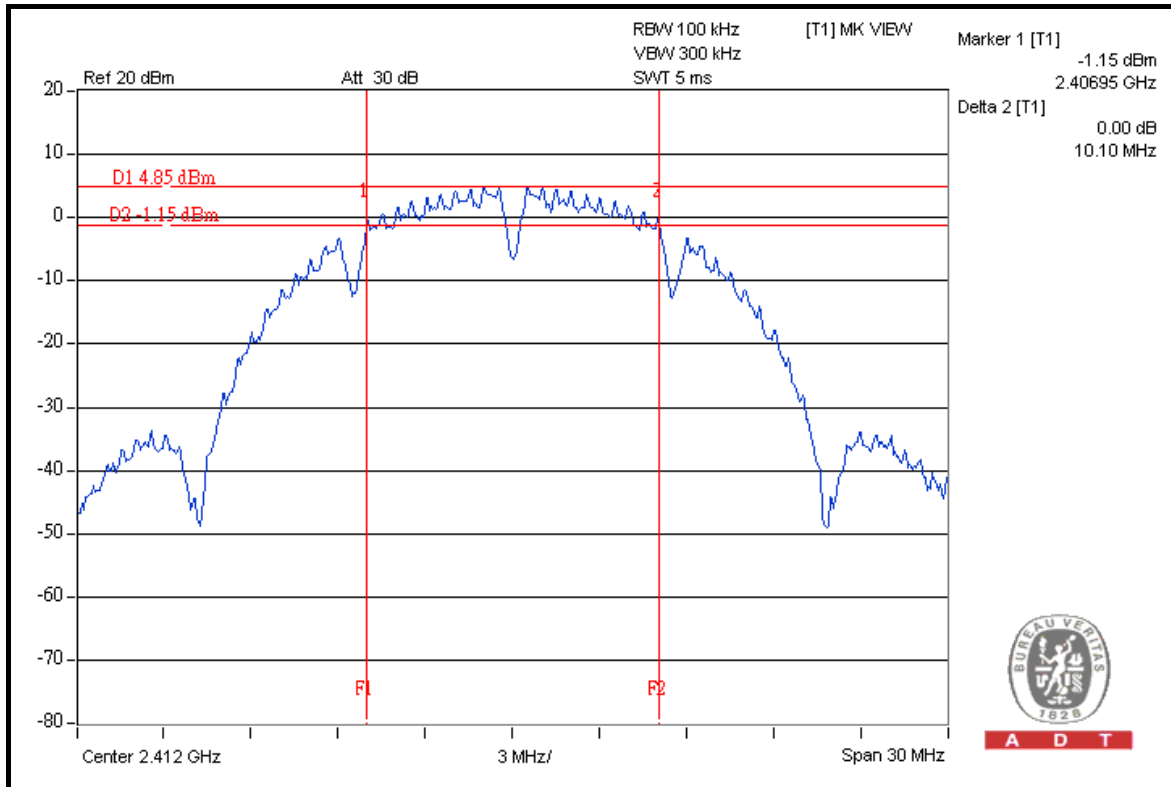

A D T



A D T

### CH 6

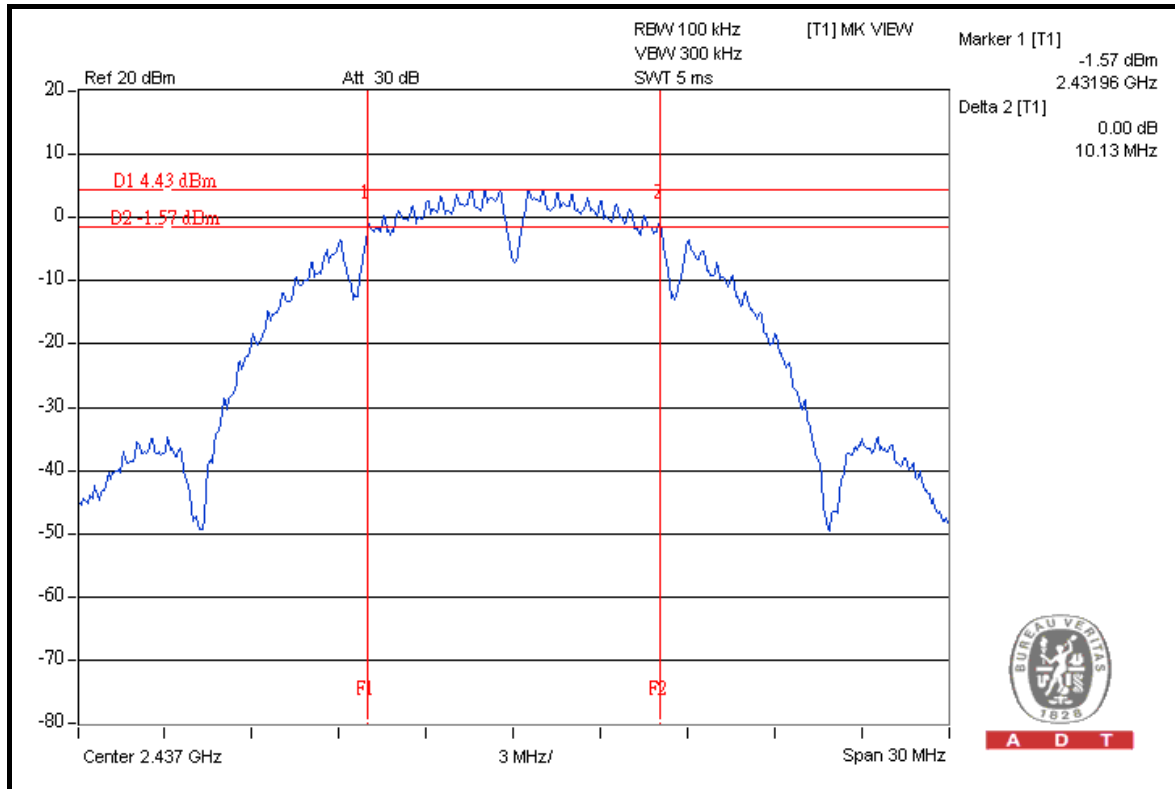

### CH 11

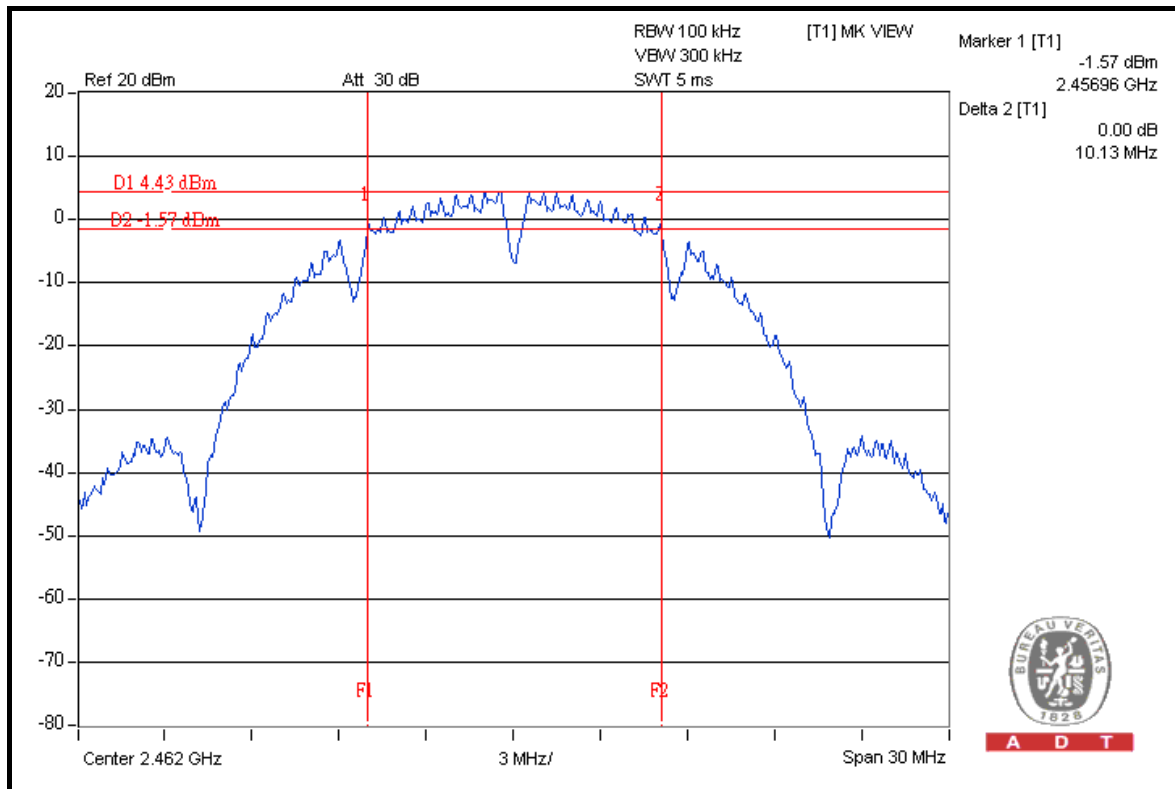





A D T

### 802.11g OFDM MODULATION

<b>MODULATION TYPE</b>	BPSK	<b>TRANSFER RATE</b>	6.0Mbps
<b>INPUT POWER</b>	120Vac, 60Hz	<b>ENVIRONMENTAL CONDITIONS</b>	25deg.C, 68%RH, 1009hPa
<b>TESTED BY</b>	Sun Lin		

CHANNEL	CHANNEL FREQUENCY (MHz)	6dB BANDWIDTH (MHz)	MINIMUM LIMIT (MHz)	PASS / FAIL
1	2412	16.58	0.5	PASS
6	2437	16.56	0.5	PASS
11	2462	16.58	0.5	PASS

### CH 1

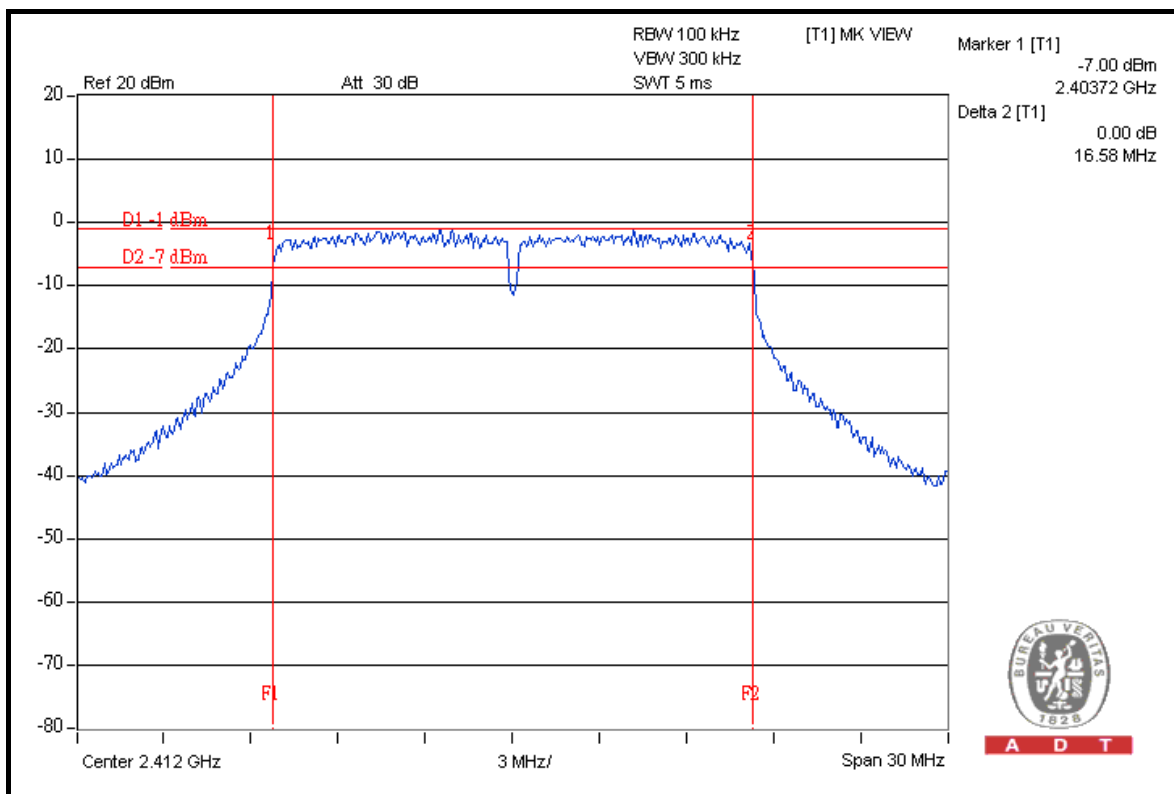

A D T



A D T

### CH 6

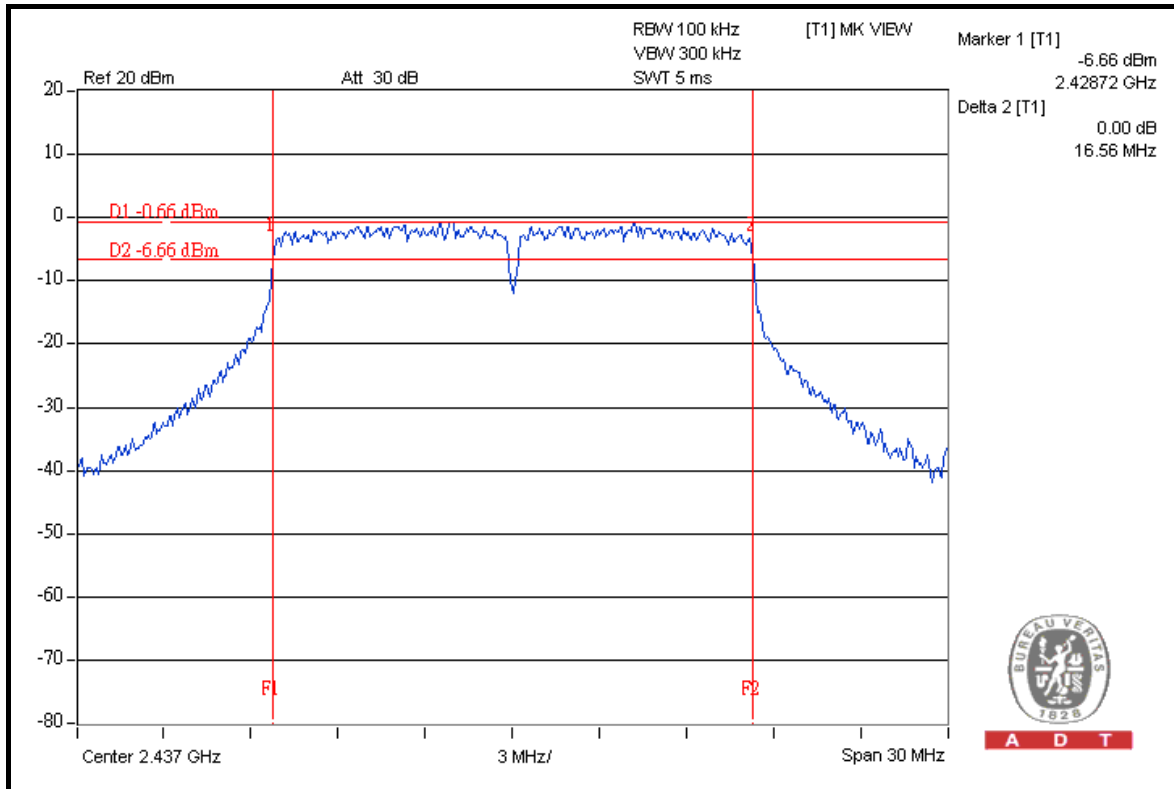

### CH 11

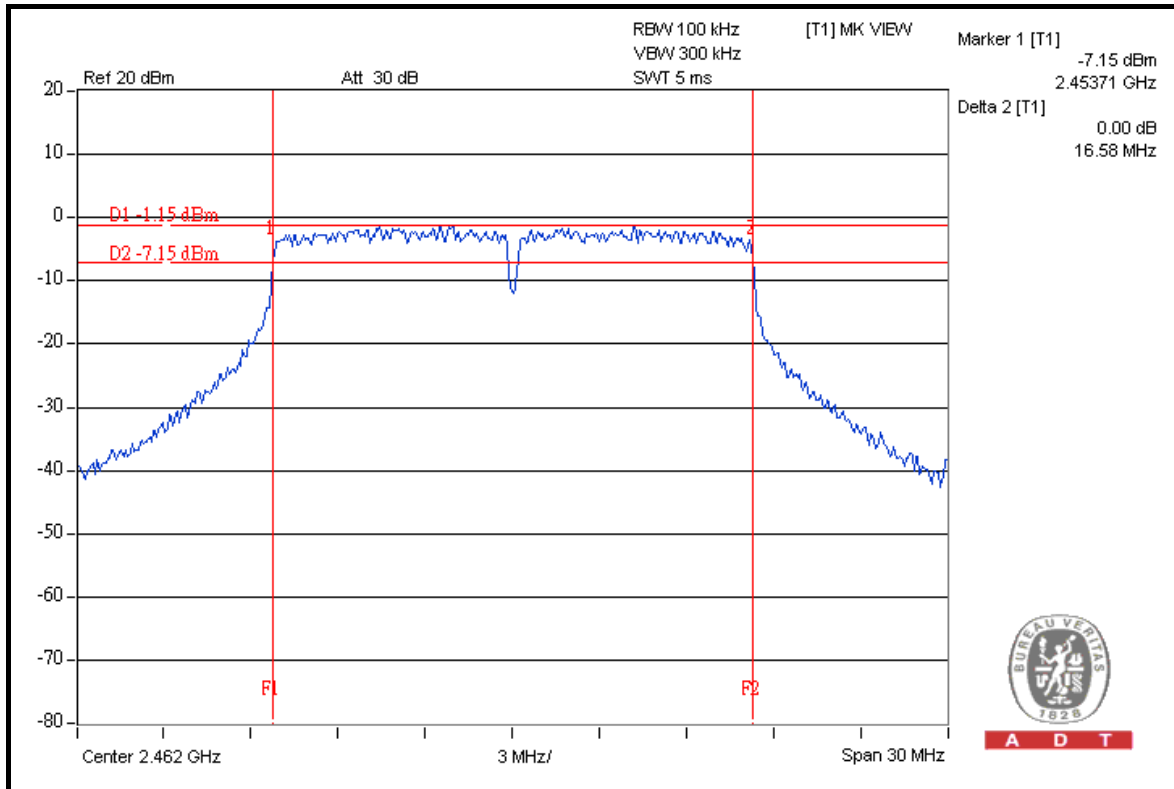



A D T

### DRAFT 802.11n (20MHz) OFDM MODULATION

<b>MODULATION TYPE</b>	BPSK	<b>TRANSFER RATE</b>	7.2Mbps
<b>INPUT POWER</b>	120Vac, 60Hz	<b>ENVIRONMENTAL CONDITIONS</b>	25deg.C, 68%RH, 1009hPa
<b>TESTED BY</b>	Sun Lin		

CHANNEL	CHANNEL FREQUENCY (MHz)	6dB BANDWIDTH (MHz)		MINIMUM LIMIT (MHz)	PASS / FAIL
		CHAIN 0	CHAIN 1		
1	2412	17.82	17.76	0.5	PASS
6	2437	17.82	17.75	0.5	PASS
11	2462	17.78	17.72	0.5	PASS



A D T

### FOR CHAIN 0: CH 1

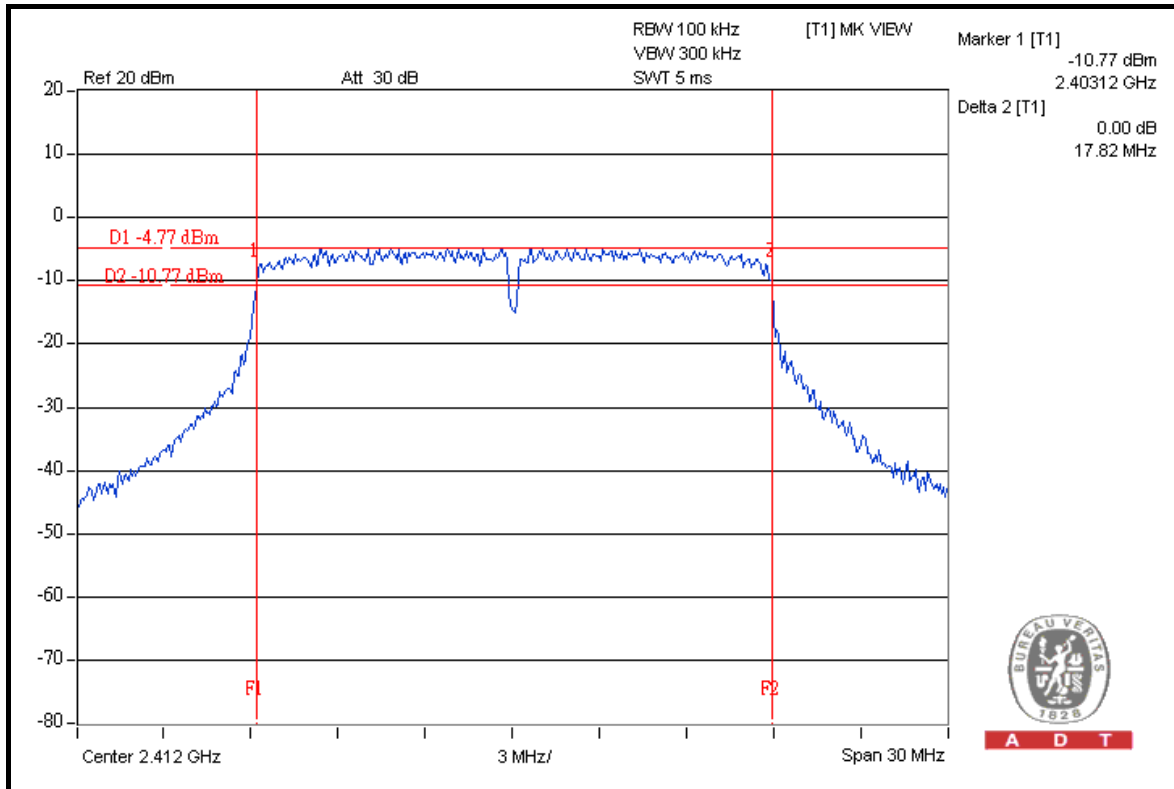

### CH 6

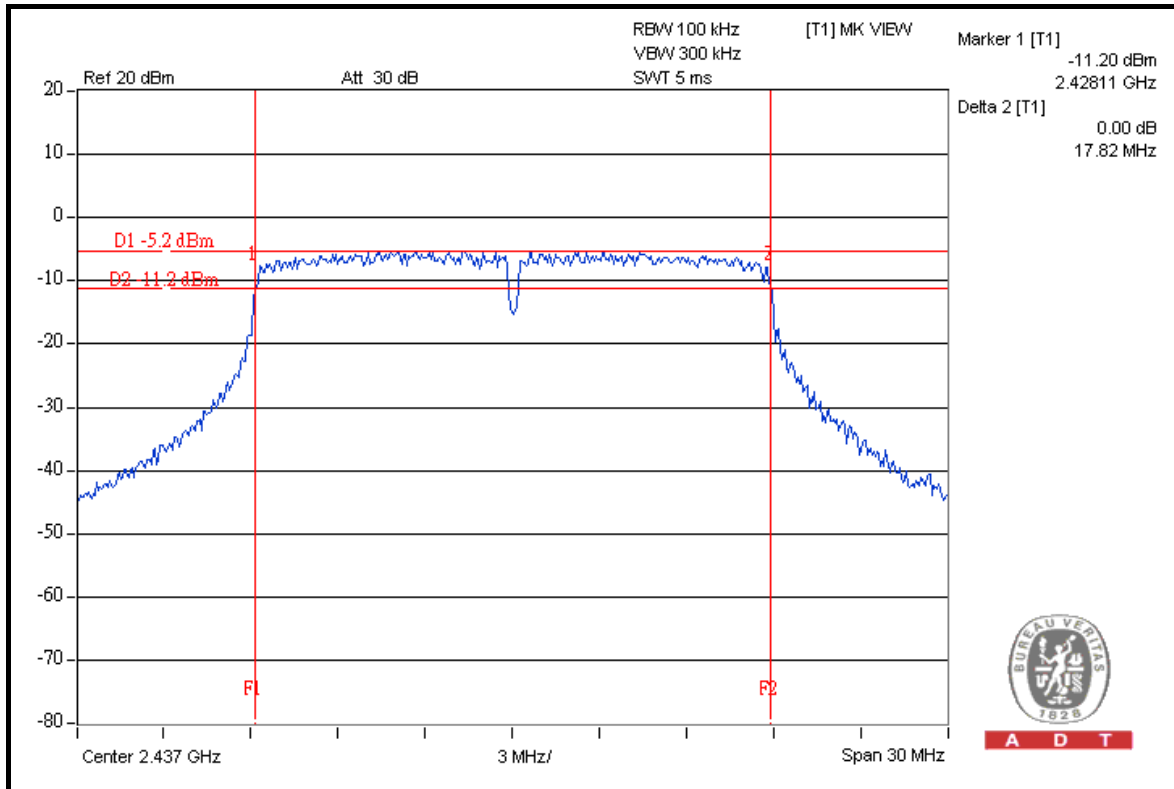



A D T

### CH 11

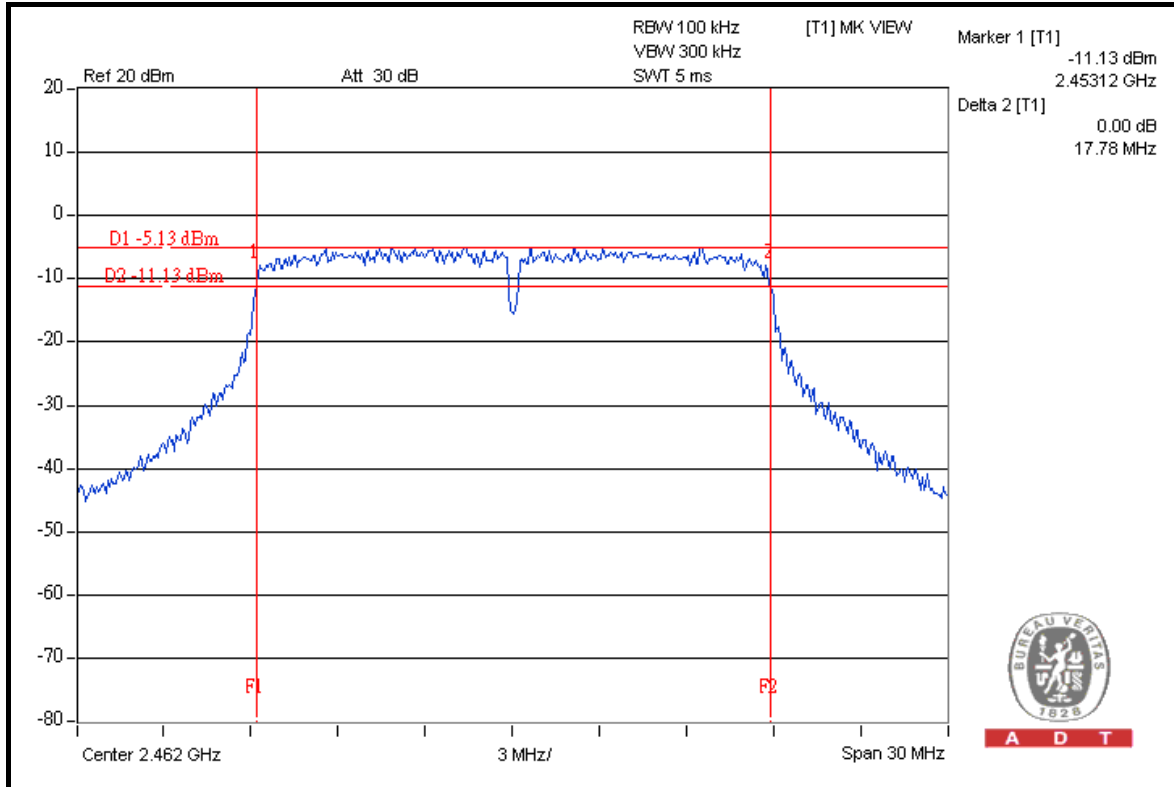

### FOR CHAIN 1: CH 1

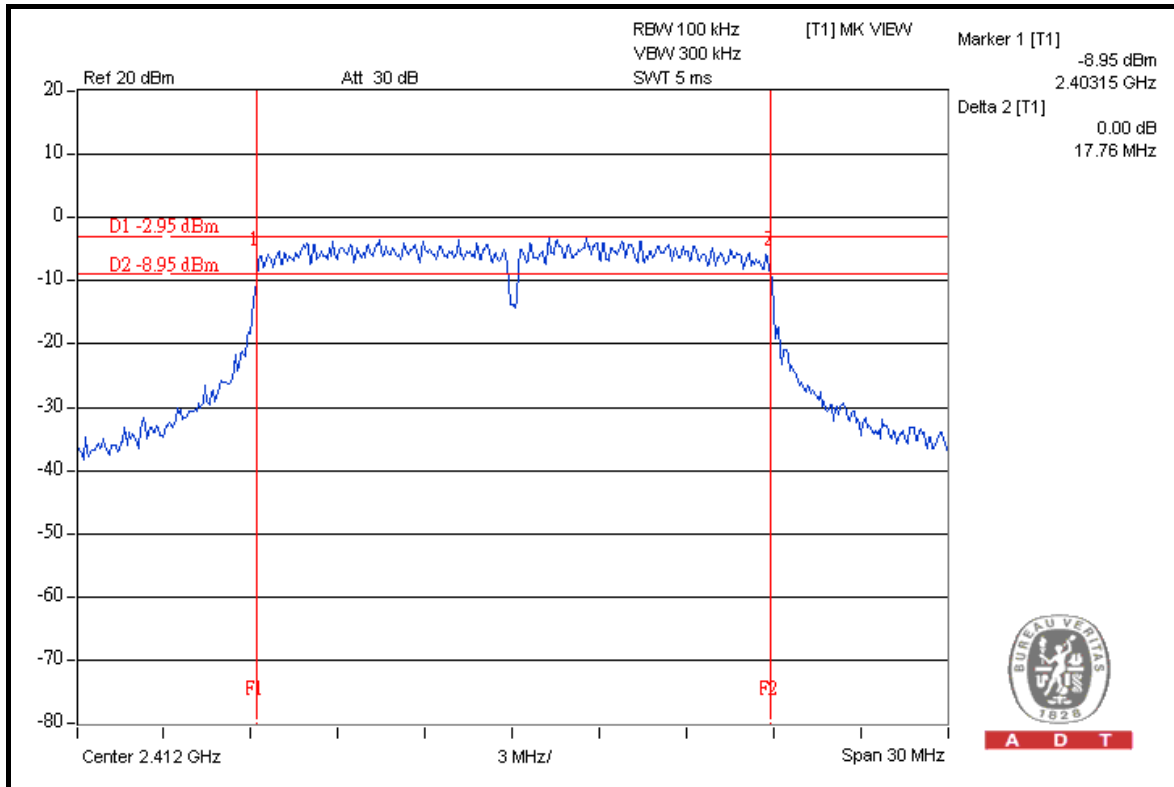



A D T

### CH 6

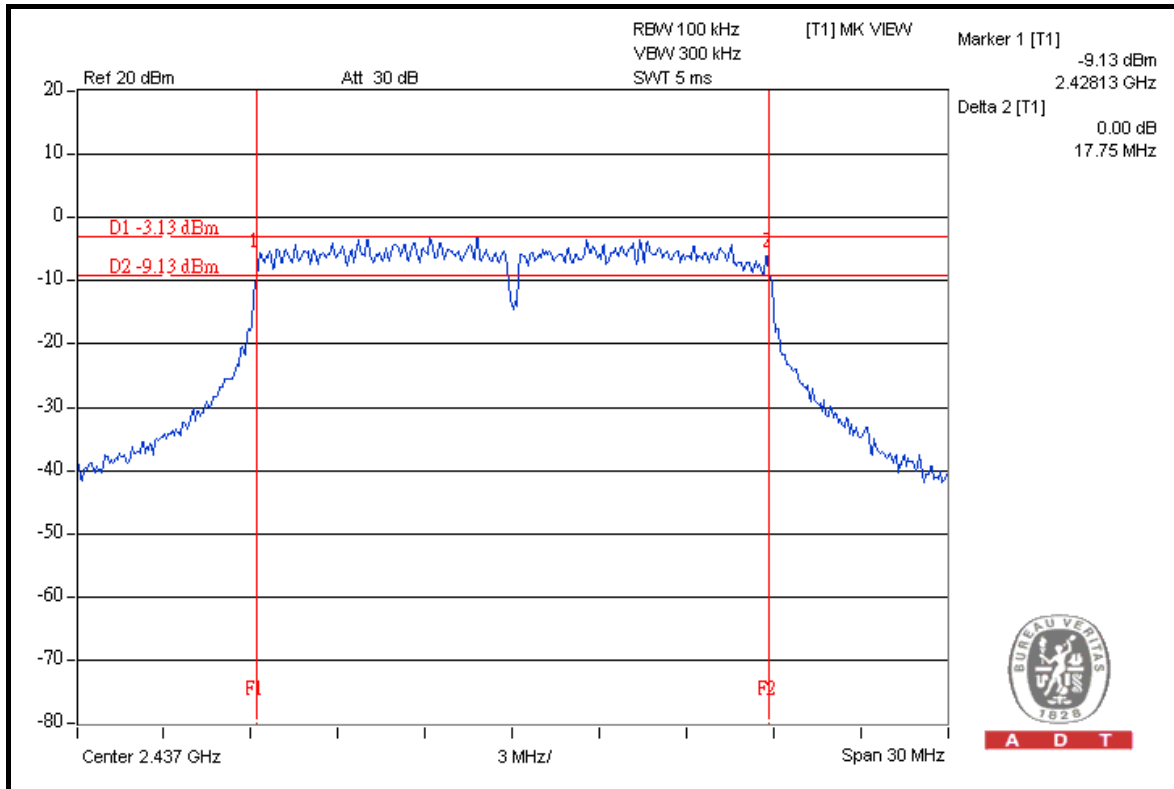

### CH 11

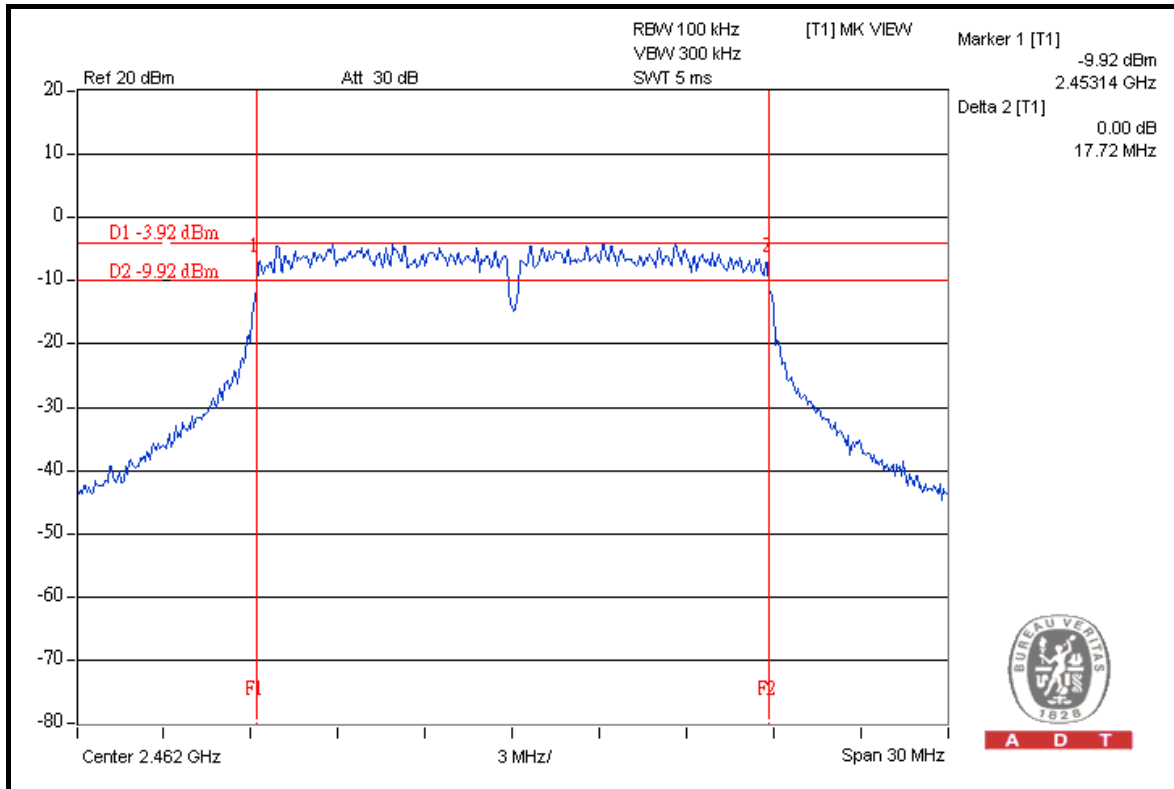



A D T

### DRAFT 802.11n (40MHz) OFDM MODULATION

<b>MODULATION TYPE</b>	BPSK	<b>TRANSFER RATE</b>	15.0Mbps
<b>INPUT POWER</b>	120Vac, 60Hz	<b>ENVIRONMENTAL CONDITIONS</b>	25deg.C, 68%RH, 1009hPa
<b>TESTED BY</b>	Sun Lin		

CHANNEL	CHANNEL FREQUENCY (MHz)	6dB BANDWIDTH (MHz)		MINIMUM LIMIT (MHz)	PASS / FAIL
		CHAIN 0	CHAIN 1		
1	2422	36.53	36.16	0.5	PASS
4	2437	36.53	36.48	0.5	PASS
7	2452	36.53	36.49	0.5	PASS



A D T

### FOR CHAIN 0: CH 1

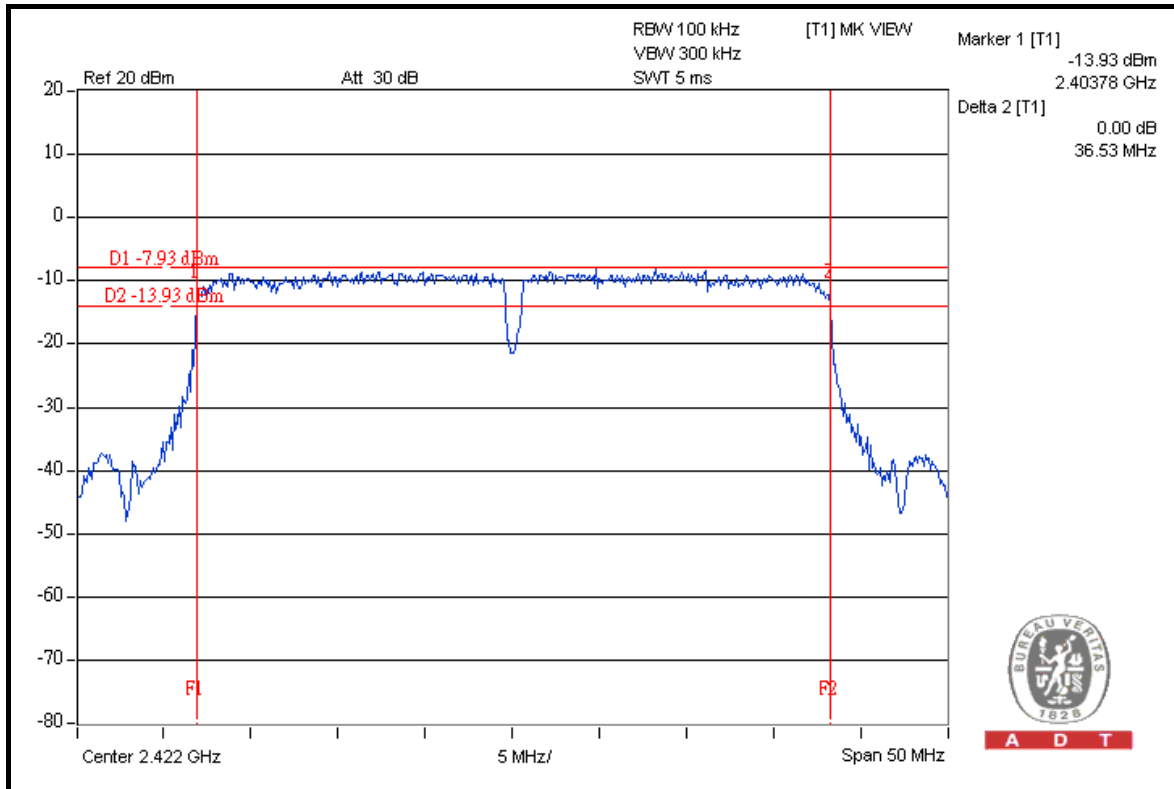

### CH 4

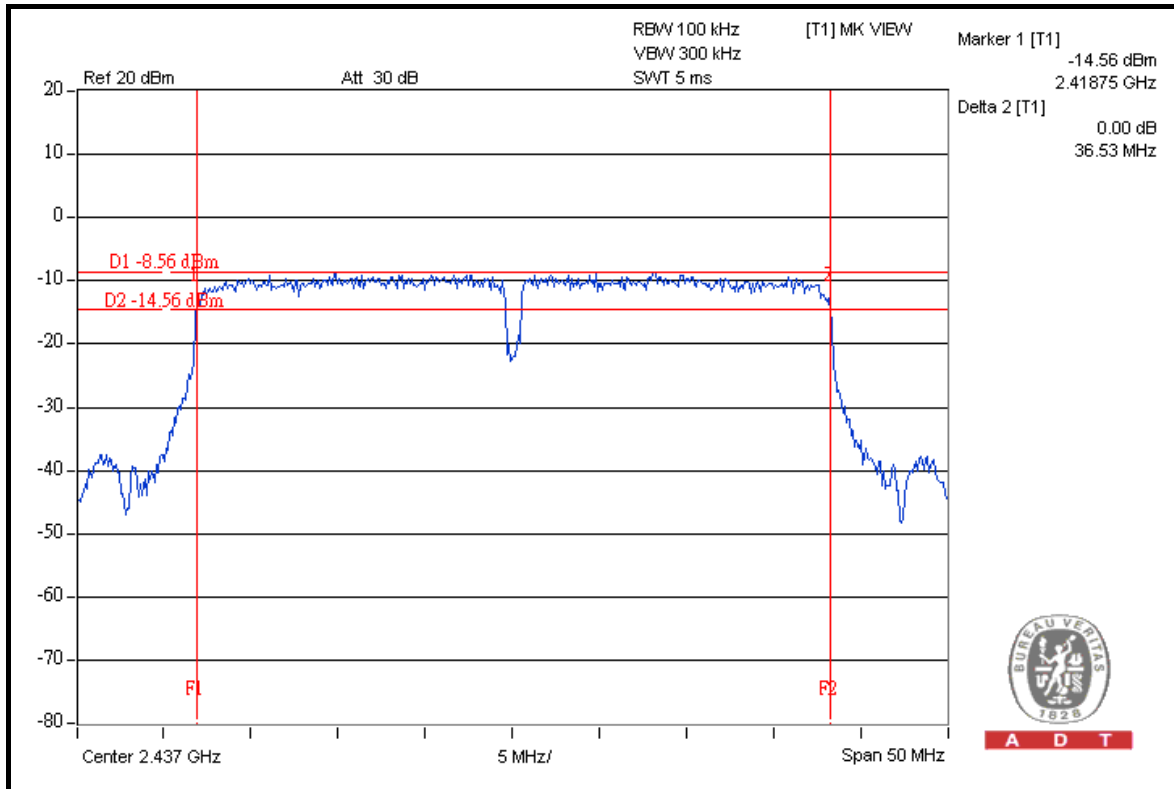





A D T

### CH 7

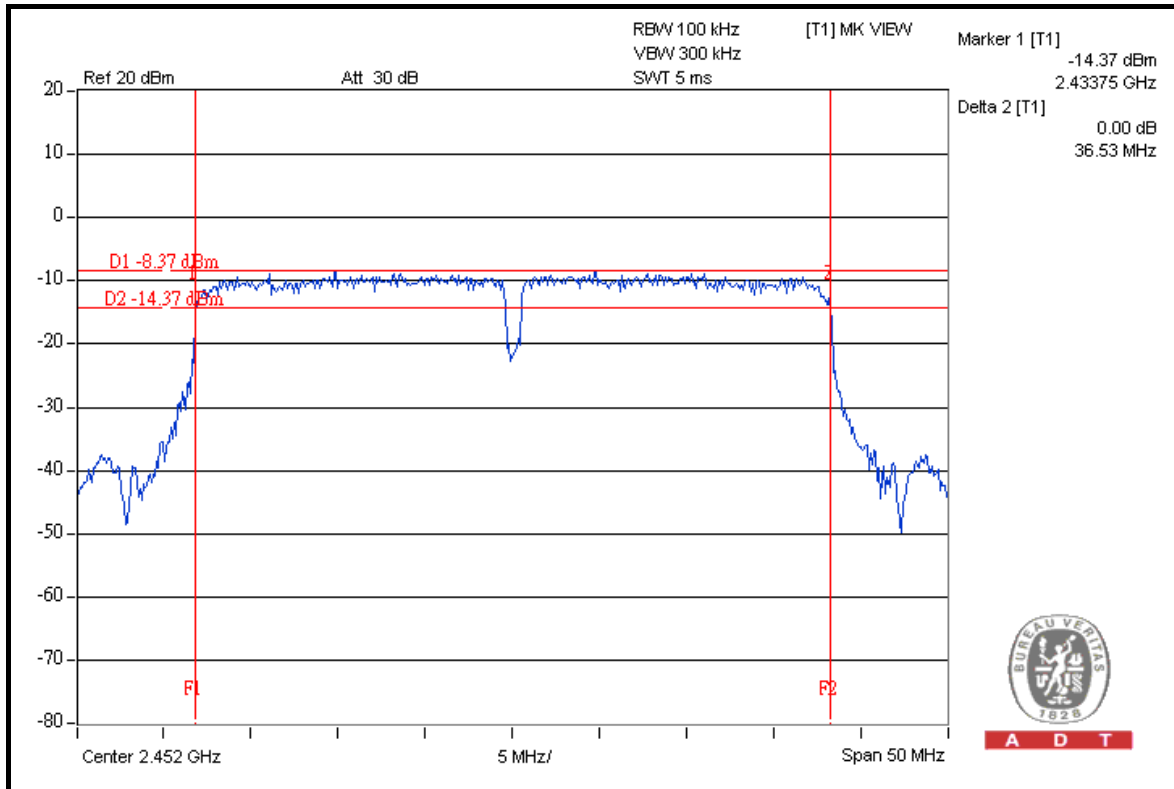

### FOR CHAIN 1: CH 1

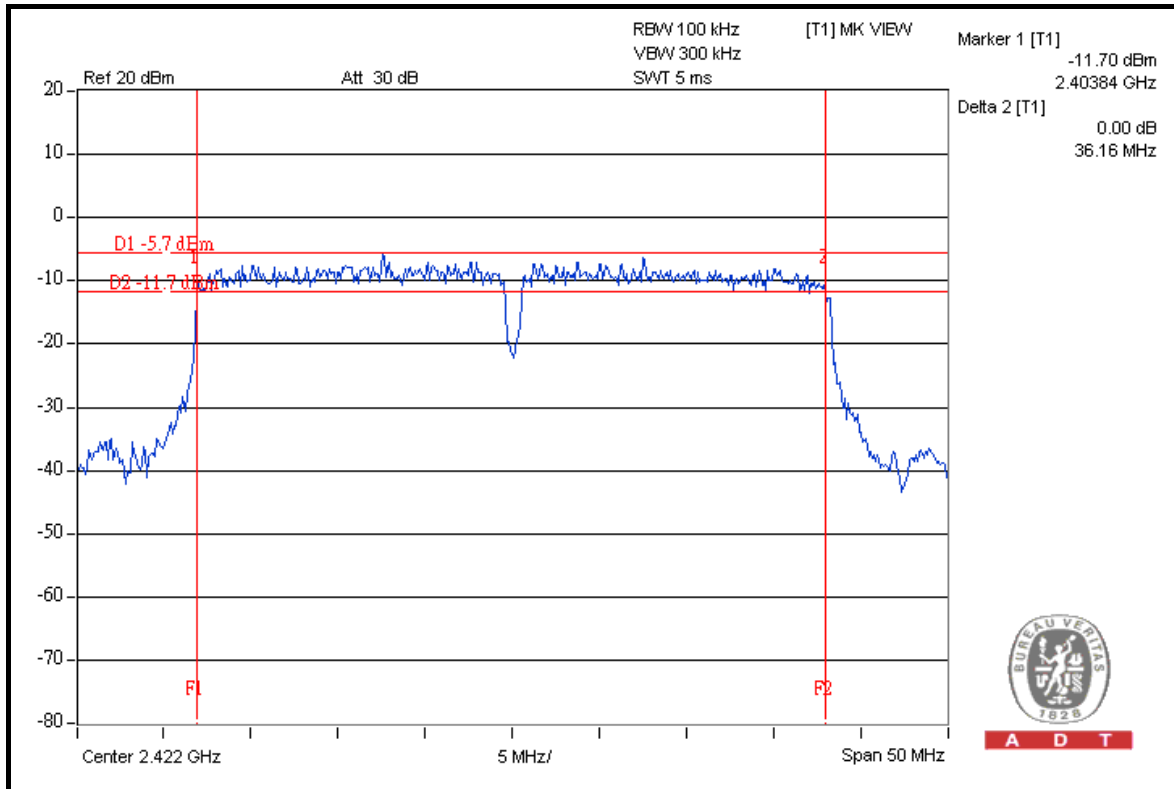



A D T

### CH 4

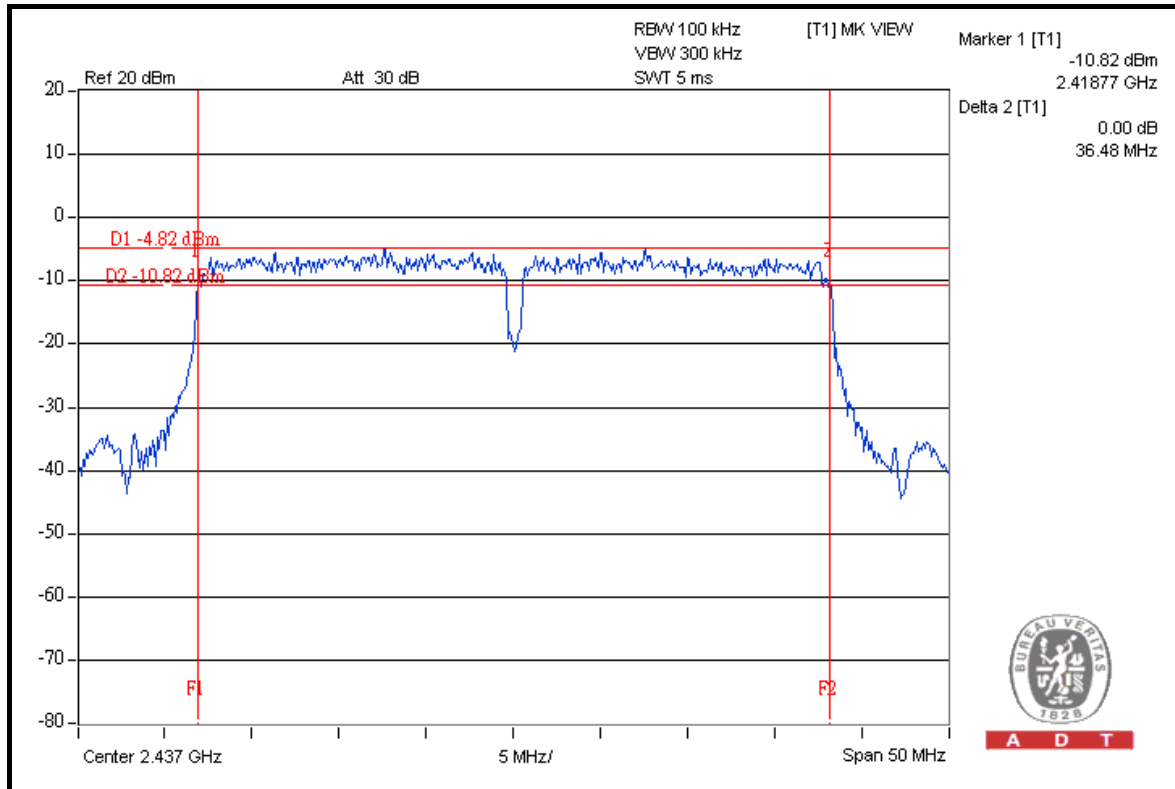

### CH 7

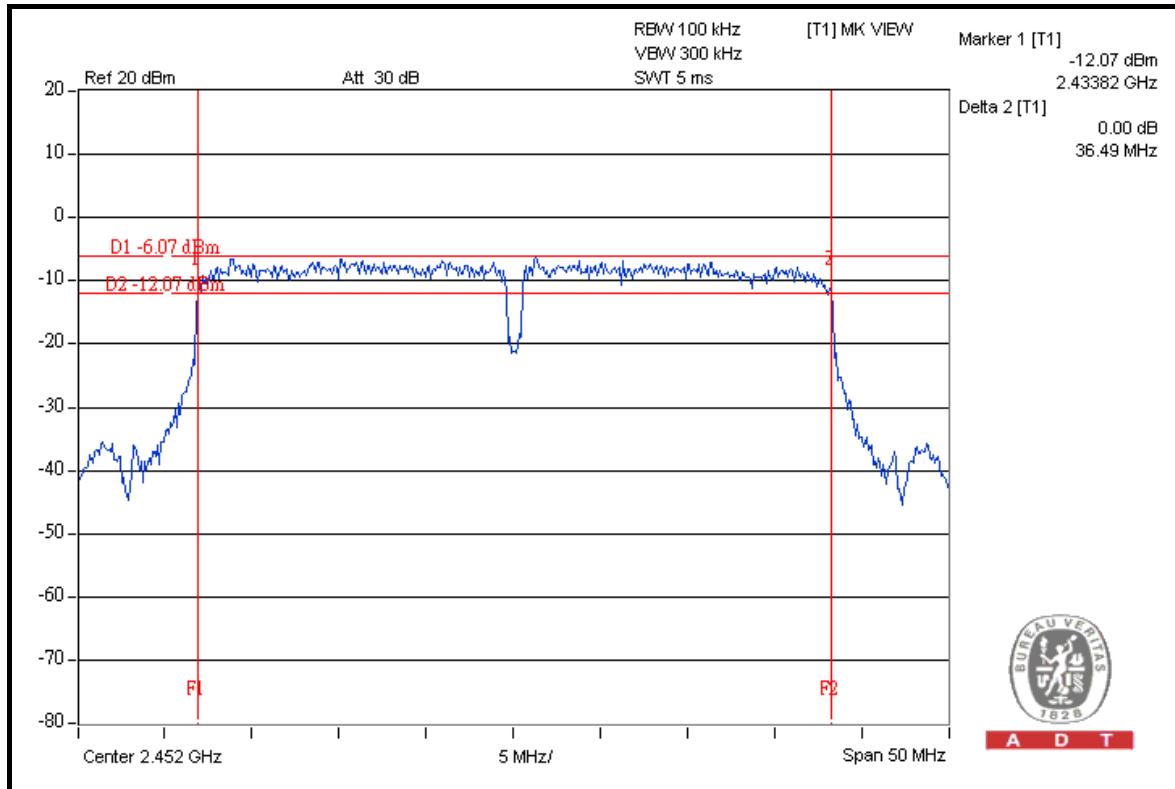



A D T

#### 4.4 MAXIMUM PEAK OUTPUT POWER

##### 4.4.1 LIMITS OF MAXIMUM PEAK OUTPUT POWER MEASUREMENT

The Maximum Peak Output Power Measurement is 30dBm.

##### 4.4.2 INSTRUMENTS

DESCRIPTION & MANUFACTURER	MODEL NO.	SERIAL NO.	DATE OF CALIBRATION	DUE DATE OF CALIBRATION
High Speed Peak Power Meter	ML2495A	0824011	Jul. 30, 2009	Jul. 29, 2010
Power Sensor	MA2411B	0738171	Jul. 30, 2009	Jul. 29, 2010

**NOTE:**

1. The calibration interval of the above test instruments is 12 months and the calibrations are traceable to NML/ROC and NIST/USA.
2. Measurement Bandwidth of ML2495A is 65MHz greater than 6dB bandwidth of emission.

##### 4.4.3 TEST PROCEDURES

A power sensor was used on the output port of the EUT. A power meter was used to read the response of the power sensor. Record the power level.

#### 4.4.4 DEVIATION FROM TEST STANDARD

No deviation.

#### 4.4.5 TEST SETUP

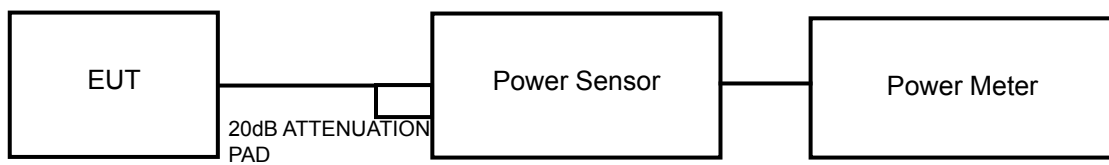

#### 4.4.6 EUT OPERATING CONDITIONS

Same as Item 4.3.6.



#### 4.4.7 TEST RESULTS

##### 802.11b DSSS MODULATION

<b>MODULATION TYPE</b>	DBPSK	<b>TRANSFER RATE</b>	1.0Mbps
<b>INPUT POWER</b>	120Vac, 60Hz	<b>ENVIRONMENTAL CONDITIONS</b>	25deg.C, 68%RH, 1009hPa
<b>TESTED BY</b>	Sun Lin		

CHAN	CHANNEL FREQUENCY (MHz)	PEAK POWER OUTPUT (mW)	PEAK POWER OUTPUT (dBm)	PEAK POWER LIMIT (dBm)	PASS/FAIL
1	2412	71.29	18.53	30	PASS
6	2437	66.07	18.20	30	PASS
11	2462	66.83	18.25	30	PASS

##### 802.11g OFDM MODULATION

<b>MODULATION TYPE</b>	BPSK	<b>TRANSFER RATE</b>	6.0Mbps
<b>INPUT POWER</b>	120Vac, 60Hz	<b>ENVIRONMENTAL CONDITIONS</b>	25deg.C, 68%RH, 1009hPa
<b>TESTED BY</b>	Sun Lin		

CHAN	CHANNEL FREQUENCY (MHz)	PEAK POWER OUTPUT (mW)	PEAK POWER OUTPUT (dBm)	PEAK POWER LIMIT (dBm)	PASS/FAIL
1	2412	207.49	23.17	30	PASS
6	2437	217.77	23.38	30	PASS
11	2462	193.20	22.86	30	PASS



A D T

### DRAFT 802.11n (20MHz) OFDM MODULATION

<b>MODULATION TYPE</b>	BPSK	<b>TRANSFER RATE</b>	7.2Mbps
<b>INPUT POWER</b>	120Vac, 60Hz	<b>ENVIRONMENTAL CONDITIONS</b>	25deg.C, 68%RH, 1009hPa
<b>TESTED BY</b>	Sun Lin		

CHAN.	CHAN. FREQ. (MHz)	PEAK POWER OUTPUT (dBm)		TOTAL PEAK POWER (mW)	TOTAL PEAK POWER (dBm)	PEAK POWER LIMIT (dBm)	PASS / FAIL
		CHAIN 0	CHAIN 1				
1	2412	20.02	20.35	208.85	23.20	30	PASS
6	2437	19.61	20.31	198.81	22.98	30	PASS
11	2462	19.47	19.42	176.01	22.46	30	PASS

### DRAFT 802.11n (40MHz) OFDM MODULATION

<b>MODULATION TYPE</b>	BPSK	<b>TRANSFER RATE</b>	15.0Mbps
<b>INPUT POWER</b>	120Vac, 60Hz	<b>ENVIRONMENTAL CONDITIONS</b>	25deg.C, 68%RH, 1009hPa
<b>TESTED BY</b>	Sun Lin		

CHAN.	CHAN. FREQ. (MHz)	PEAK POWER OUTPUT (dBm)		TOTAL PEAK POWER (mW)	TOTAL PEAK POWER (dBm)	PEAK POWER LIMIT (dBm)	PASS / FAIL
		CHAIN 0	CHAIN 1				
1	2422	19.23	19.11	165.22	22.18	30	PASS
4	2437	18.81	19.96	175.12	22.43	30	PASS
7	2452	18.77	18.94	153.68	21.87	30	PASS

## 4.5 POWER SPECTRAL DENSITY MEASUREMENT

### 4.5.1 LIMITS OF POWER SPECTRAL DENSITY MEASUREMENT

The Maximum of Power Spectral Density Measurement is 8dBm.

### 4.5.2 TEST INSTRUMENTS

DESCRIPTION & MANUFACTURER	MODEL NO.	SERIAL NO.	DATE OF CALIBRATION	DUE DATE OF CALIBRATION
R&S SPECTRUM ANALYZER	FSP40	100041	May 13, 2009	May 12, 2010

**NOTE:** The calibration interval of the above test instruments is 12 months and the calibrations are traceable to NML/ROC and NIST/USA.

### 4.5.3 TEST PROCEDURE

The transmitter output was connected to the spectrum analyzer through an attenuator, the bandwidth of the fundamental frequency was measured with the spectrum analyzer using 3kHz RBW and 30kHz VBW, set sweep time = span/3kHz. The power spectral density was measured and recorded.

The sweep time is allowed to be longer than span/3kHz for a full response of the mixer in the spectrum analyzer.

#### 4.5.4 DEVIATION FROM TEST STANDARD

No deviation.

#### 4.5.5 TEST SETUP

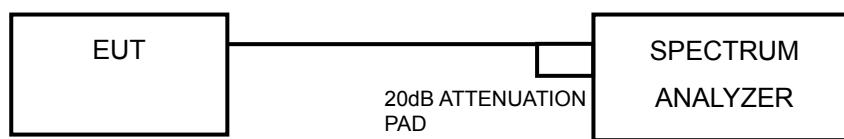

#### 4.5.6 EUT OPERATING CONDITION

Same as Item 4.3.6





A D T

### 4.5.7 TEST RESULTS

#### 802.11b DSSS MODULATION

<b>MODULATION TYPE</b>	DBPSK	<b>TRANSFER RATE</b>	1.0Mbps
<b>INPUT POWER</b>	120Vac, 60Hz	<b>ENVIRONMENTAL CONDITIONS</b>	25deg.C, 68%RH, 1009hPa
<b>TESTED BY</b>	Sun Lin		

CHANNEL	CHANNEL FREQUENCY (MHz)	RF POWER LEVEL IN 3 kHz BW (dBm)	MAXIMUM LIMIT (dBm)	PASS/FAIL
1	2412	-14.65	8	PASS
6	2437	-14.81	8	PASS
11	2462	-15.14	8	PASS

#### CH 1

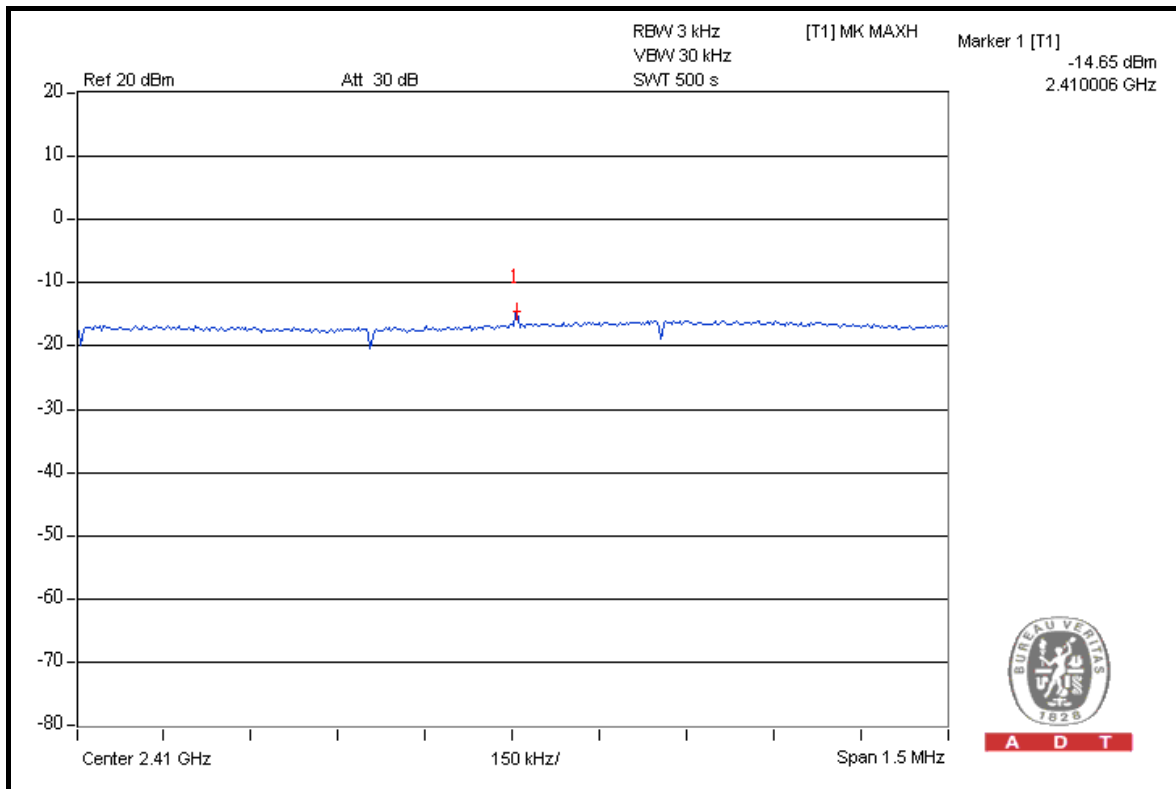

A D T



A D T

### CH 6

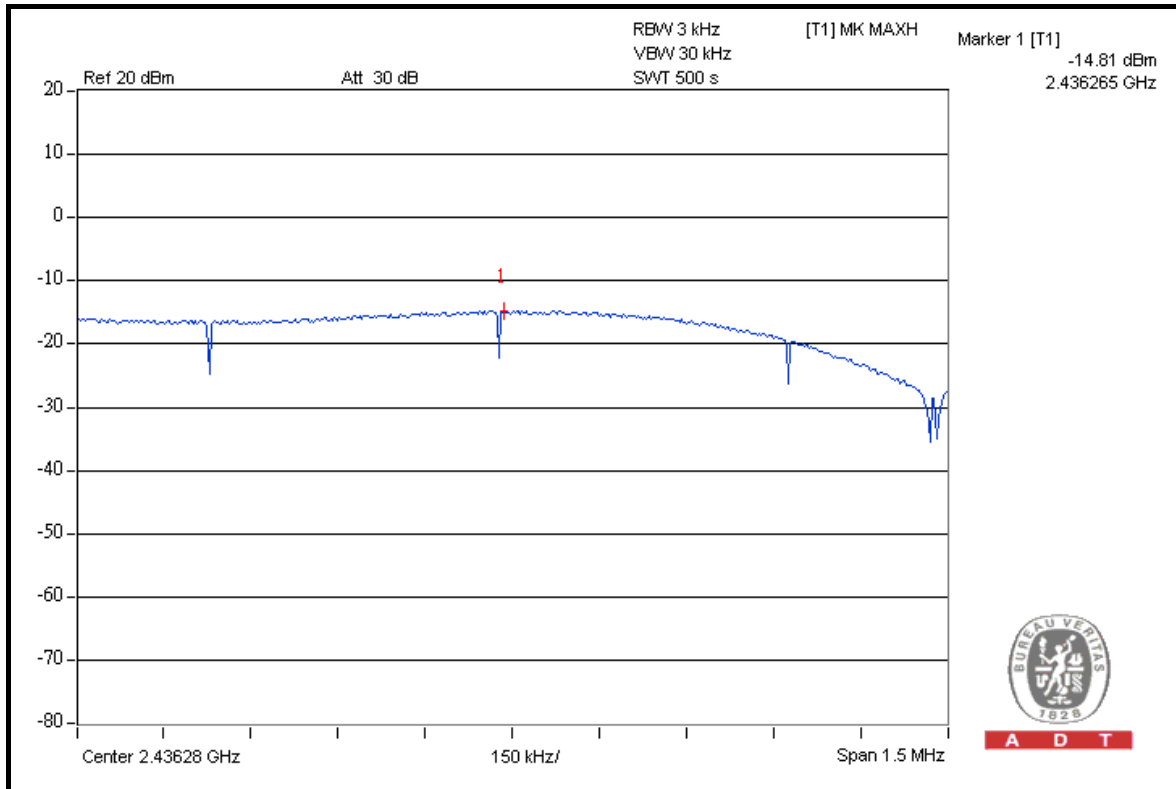

A D T

### CH 11

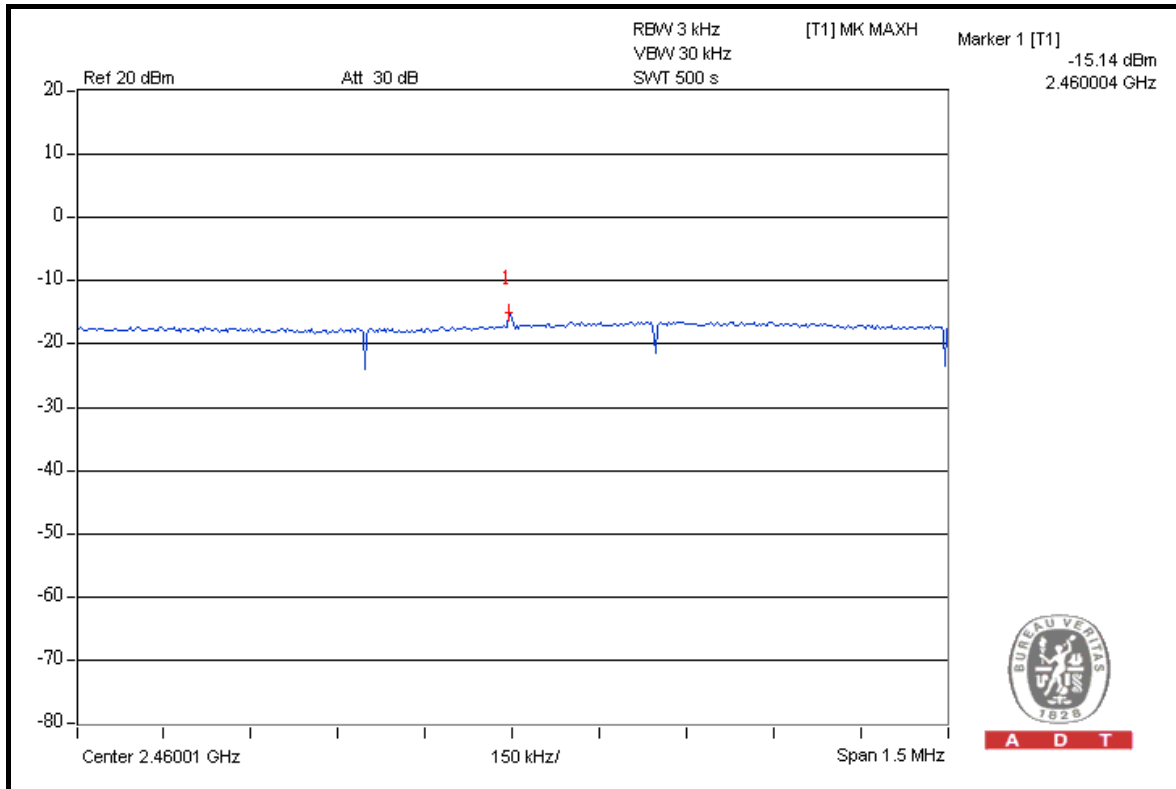

A D T



A D T

### 802.11g OFDM MODULATION

<b>MODULATION TYPE</b>	BPSK	<b>TRANSFER RATE</b>	6.0Mbps
<b>INPUT POWER</b>	120Vac, 60Hz	<b>ENVIRONMENTAL CONDITIONS</b>	25deg.C, 68%RH, 1009hPa
<b>TESTED BY</b>	Sun Lin		

CHANNEL	CHANNEL FREQUENCY (MHz)	RF POWER LEVEL IN 3 kHz BW (dBm)	MAXIMUM LIMIT (dBm)	PASS/FAIL
1	2412	-15.71	8	PASS
6	2437	-15.26	8	PASS
11	2462	-16.06	8	PASS

### CH 1

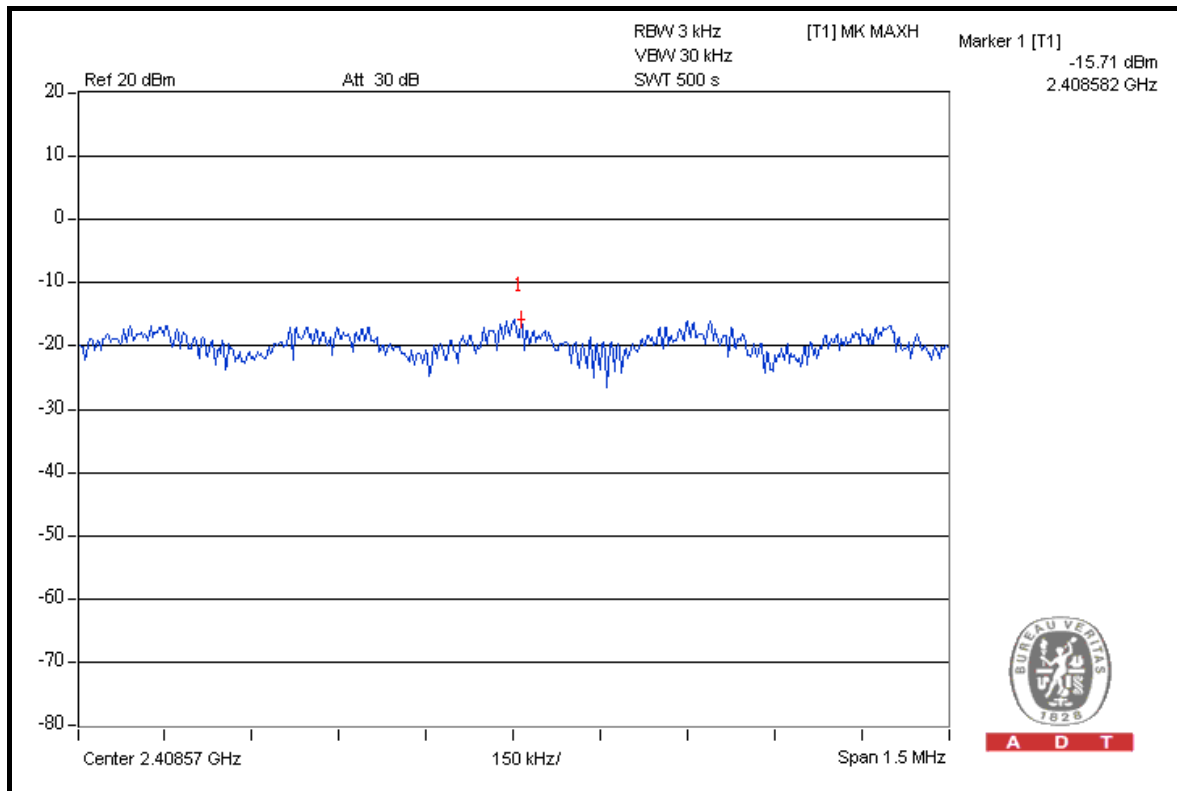



A D T

### CH 6

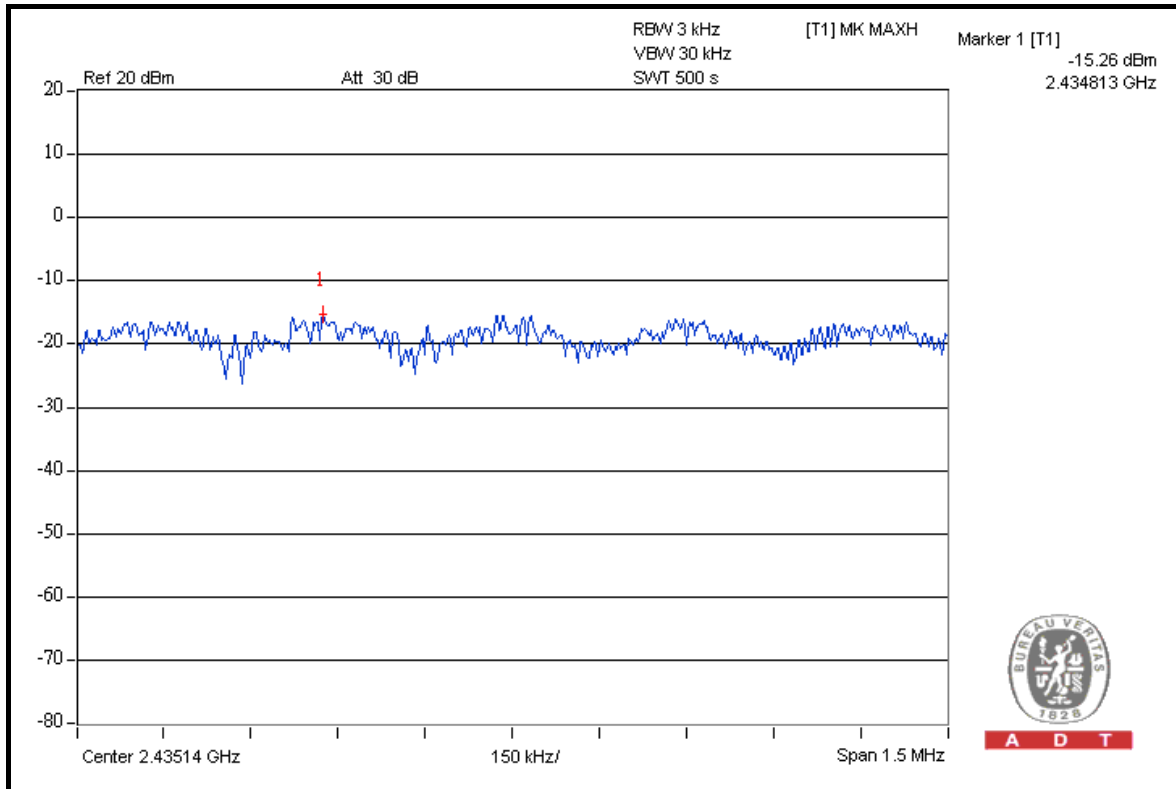

### CH 11

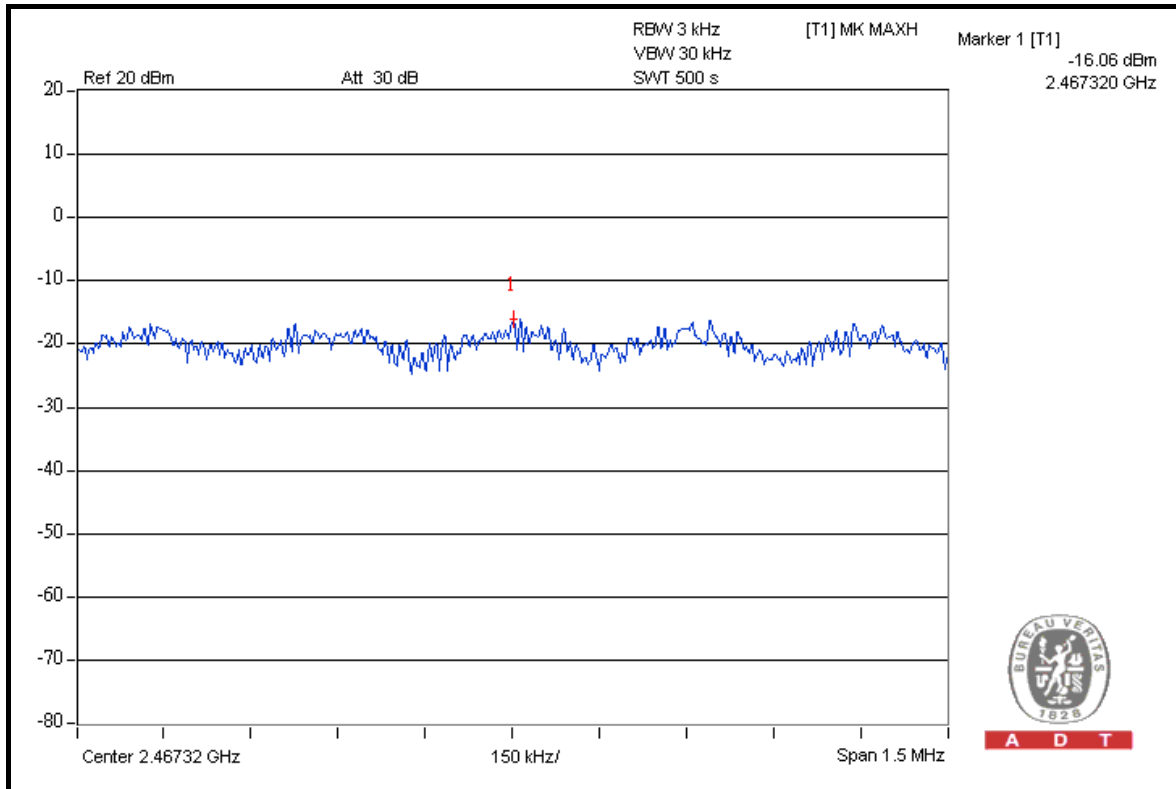



A D T

**DRAFT 802.11n (20MHz) OFDM MODULATION**

<b>MODULATION TYPE</b>	BPSK	<b>TRANSFER RATE</b>	7.2Mbps
<b>INPUT POWER</b>	120Vac, 60Hz	<b>ENVIRONMENTAL CONDITIONS</b>	25deg.C, 68%RH, 1009hPa
<b>TESTED BY</b>	Sun Lin		

CHAN.	CHAN. FREQ. (MHz)	RF POWER LEVEL IN 3kHz BW (dBm)		TOTAL POWER DENSITY (mW)	TOTAL POWER DENSITY (dBm)	MAX. LIMIT (dBm)	PASS / FAIL
		CHAIN 0	CHAIN 1				
1	2412	-18.01	-17.84	0.03	-14.95	8	PASS
6	2437	-18.56	-17.80	0.03	-15.09	8	PASS
11	2462	-18.45	-18.61	0.03	-15.53	8	PASS



A D T

### FOR CHAIN 0: CH 1

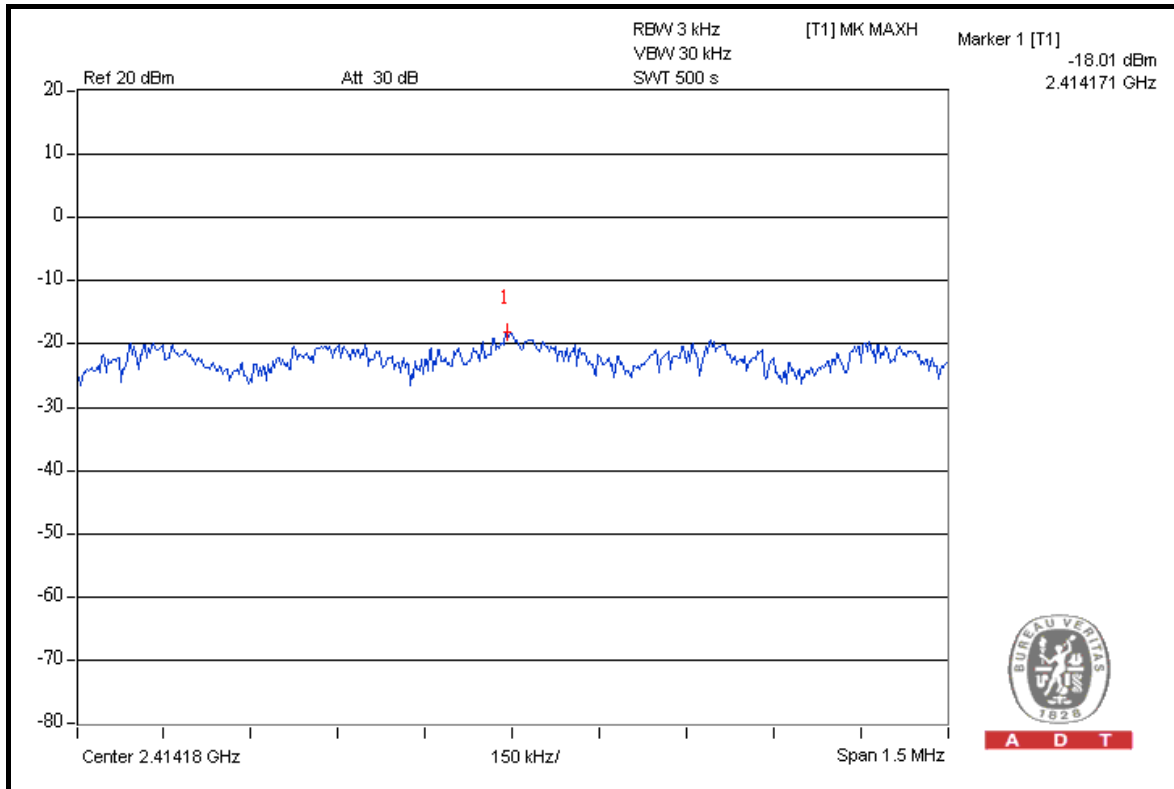

### CH 6

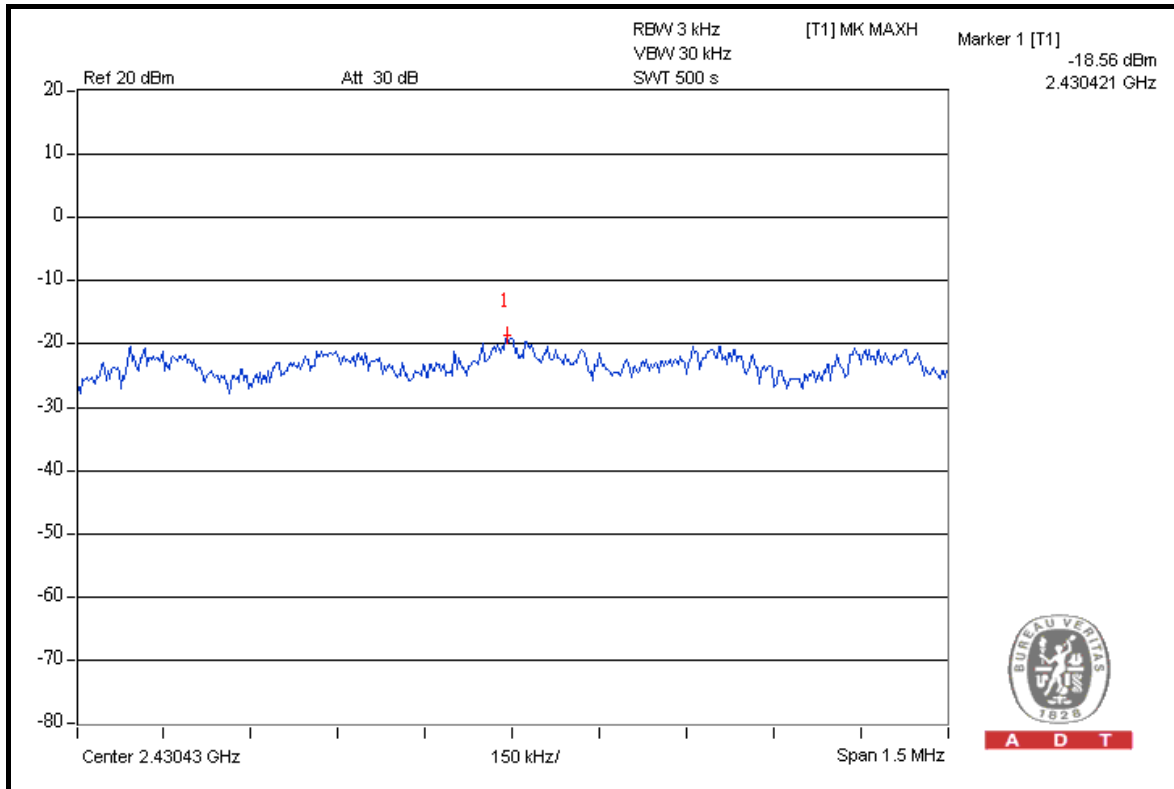



A D T

### CH 11

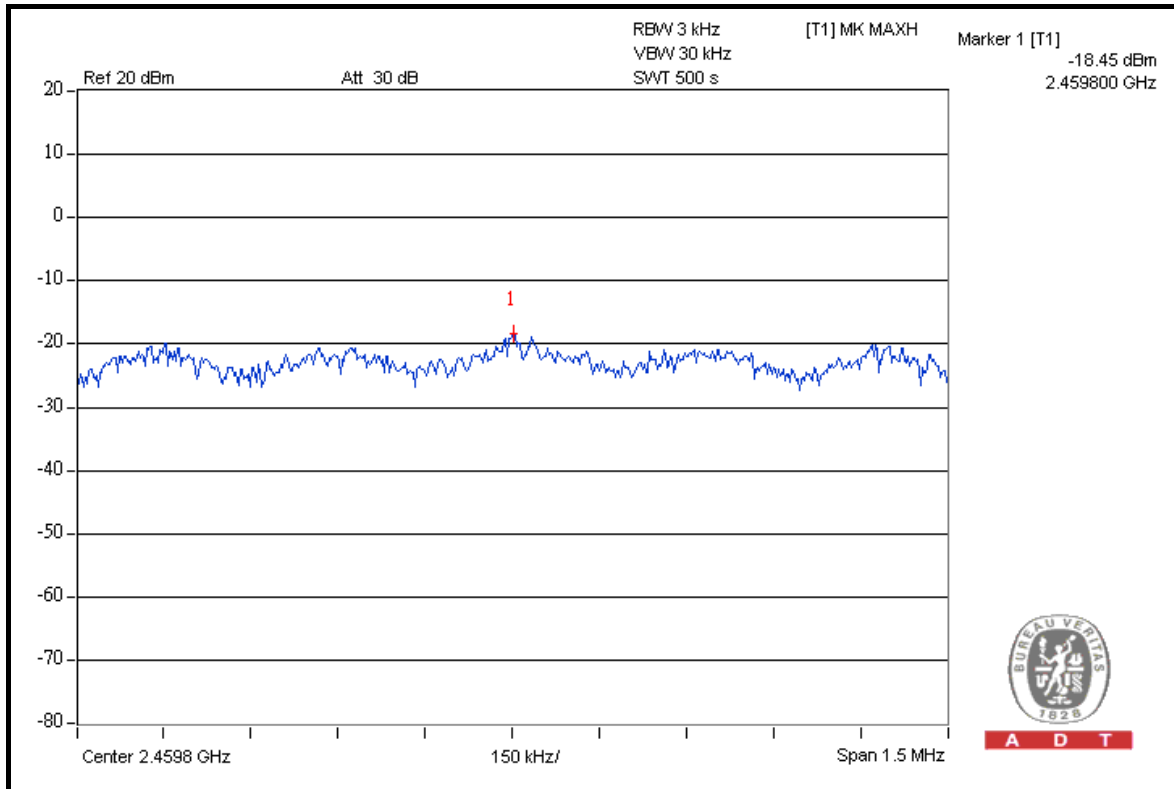

### FOR CHAIN 1: CH 1

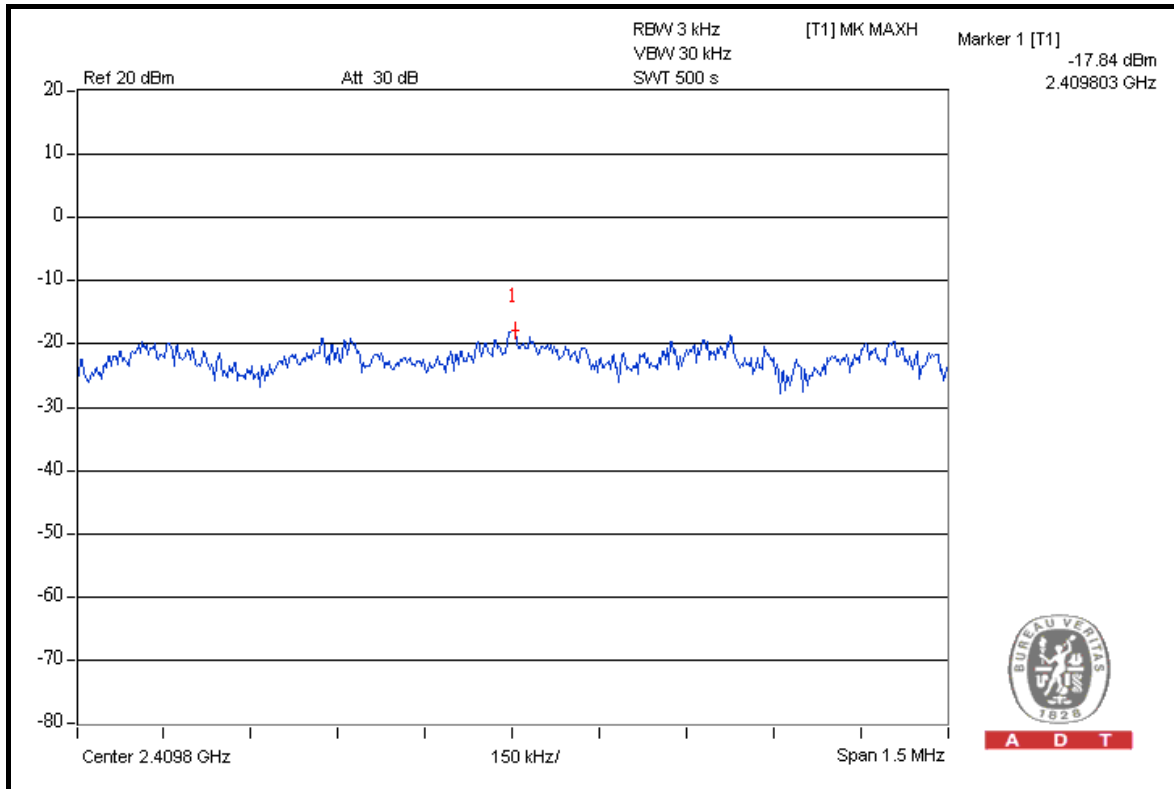



A D T

### CH 6

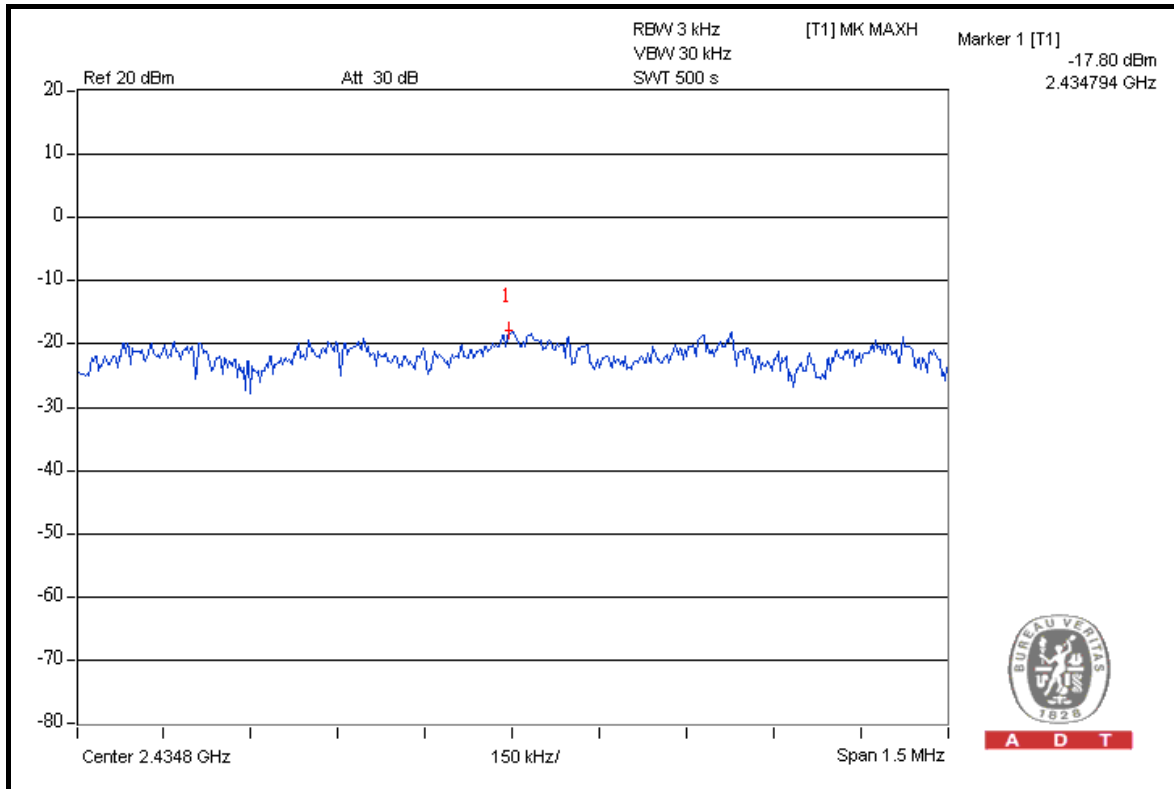

### CH 11

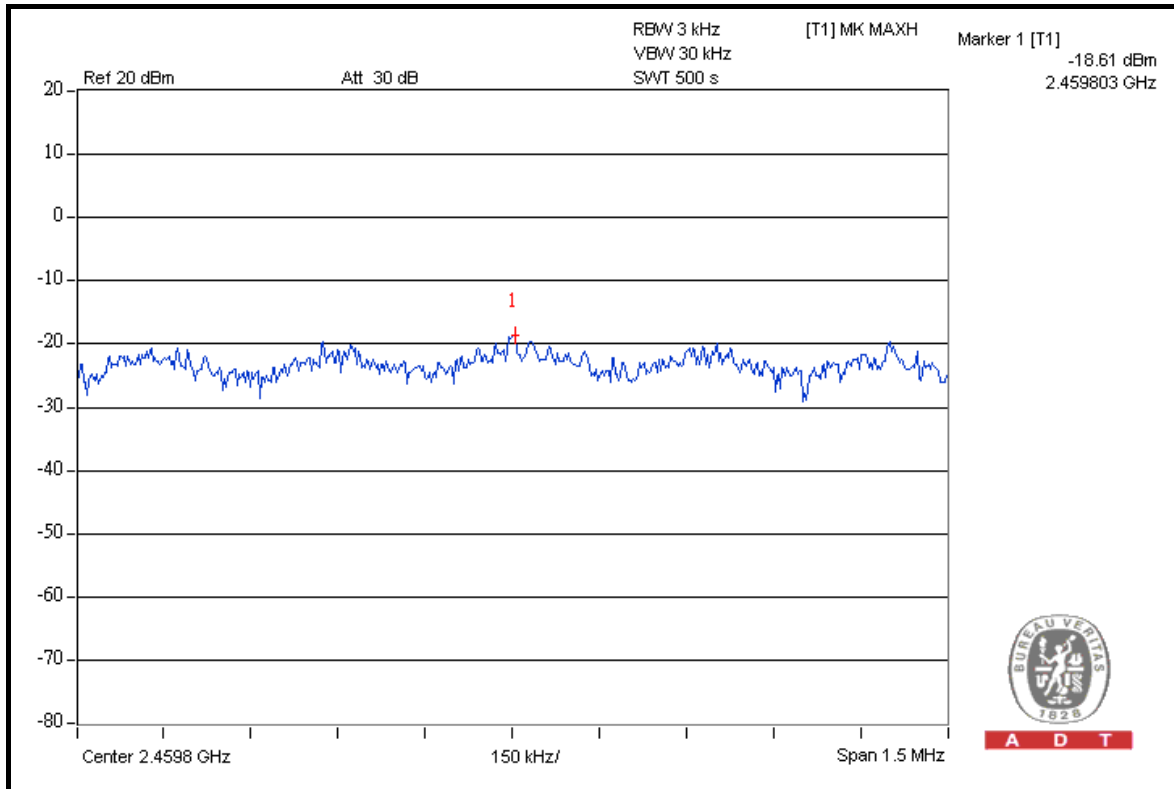





A D T

### DRAFT 802.11n (40MHz) OFDM MODULATION

<b>MODULATION TYPE</b>	BPSK	<b>TRANSFER RATE</b>	15.0Mbps
<b>INPUT POWER</b>	120Vac, 60Hz	<b>ENVIRONMENTAL CONDITIONS</b>	25deg.C, 68%RH, 1009hPa
<b>TESTED BY</b>	Sun Lin		

CHAN.	CHAN. FREQ. (MHz)	RF POWER LEVEL IN 3kHz BW (dBm)		TOTAL POWER DENSITY (mW)	TOTAL POWER DENSITY (dBm)	MAX. LIMIT (dBm)	PASS / FAIL
		CHAIN 0	CHAIN 1				
1	2422	-19.34	-20.82	0.02	-16.99	8	PASS
4	2437	-19.80	-19.82	0.02	-16.78	8	PASS
7	2452	-19.87	-20.91	0.02	-17.45	8	PASS



A D T

### FOR CHAIN 0: CH 1

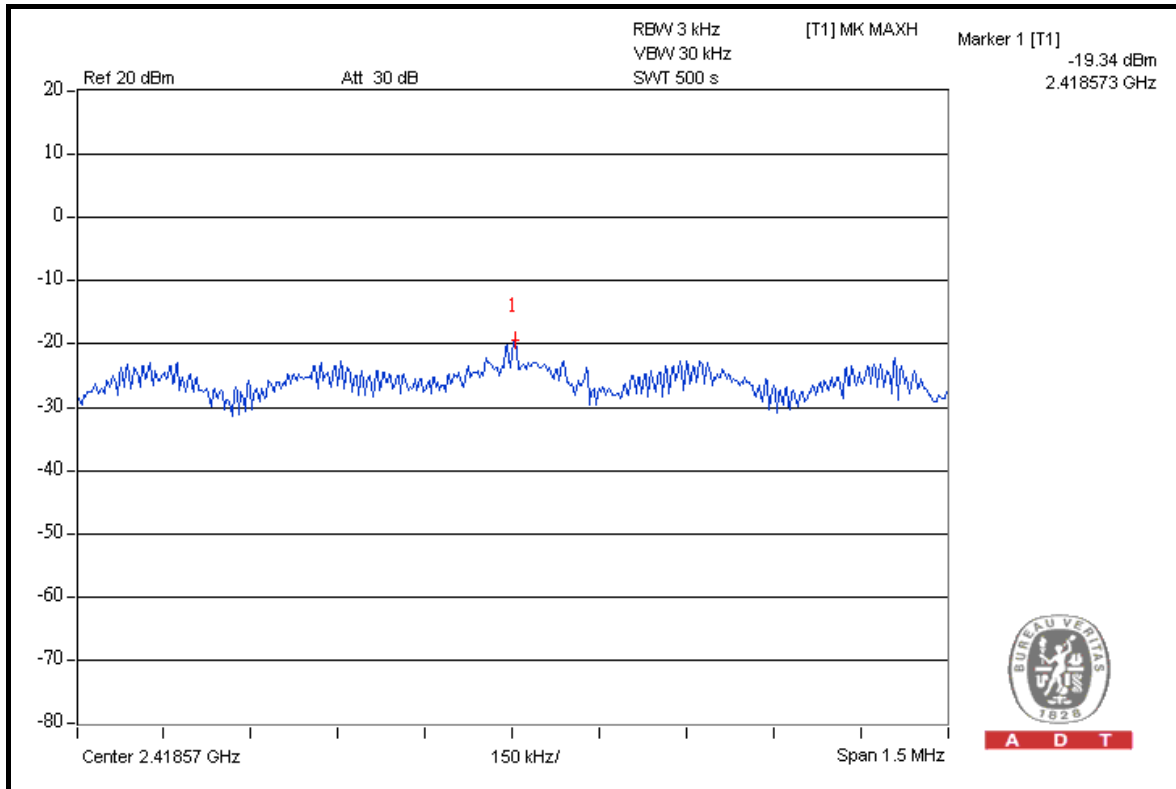

### CH 4

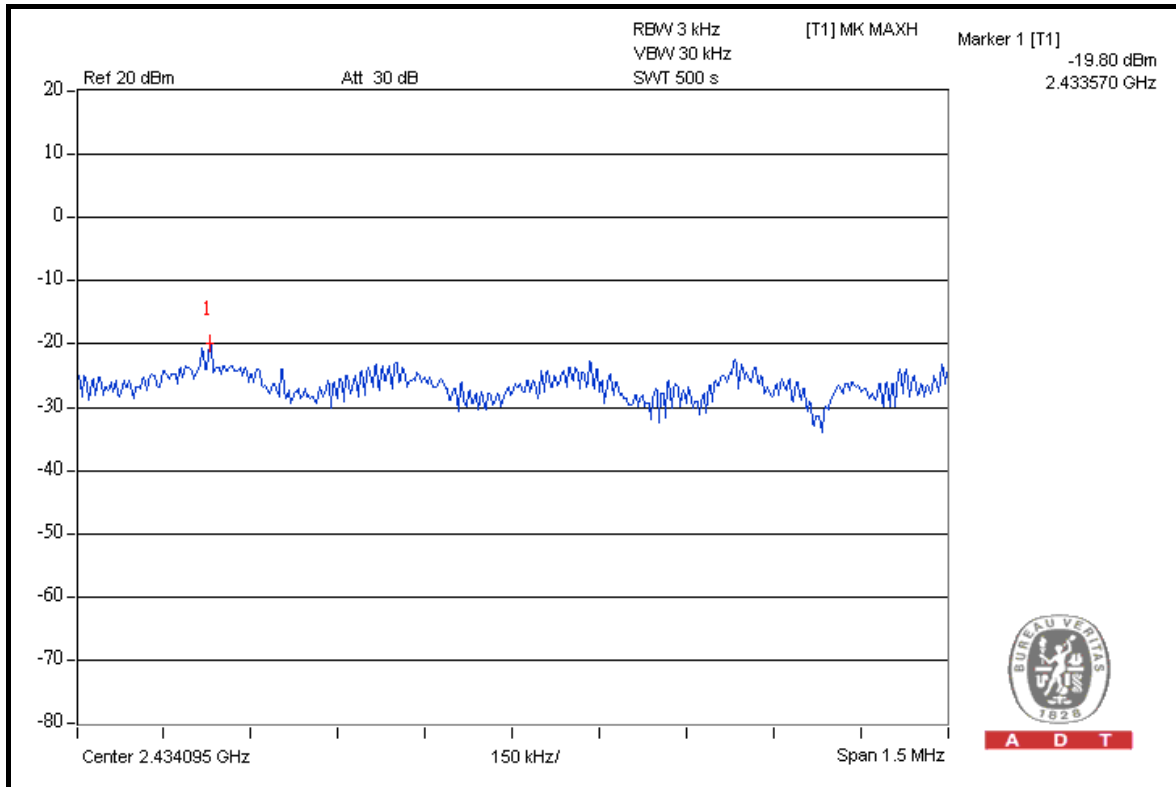



A D T

### CH 7

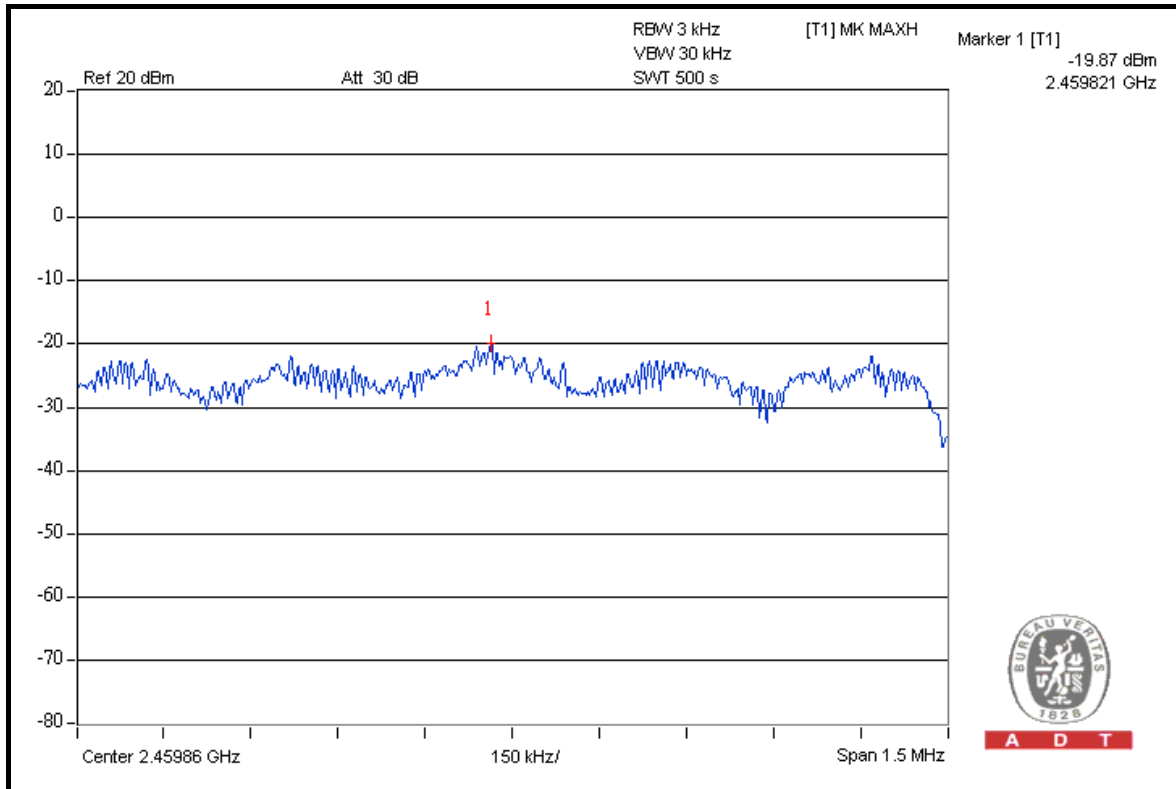

### FOR CHAIN 1: CH 1

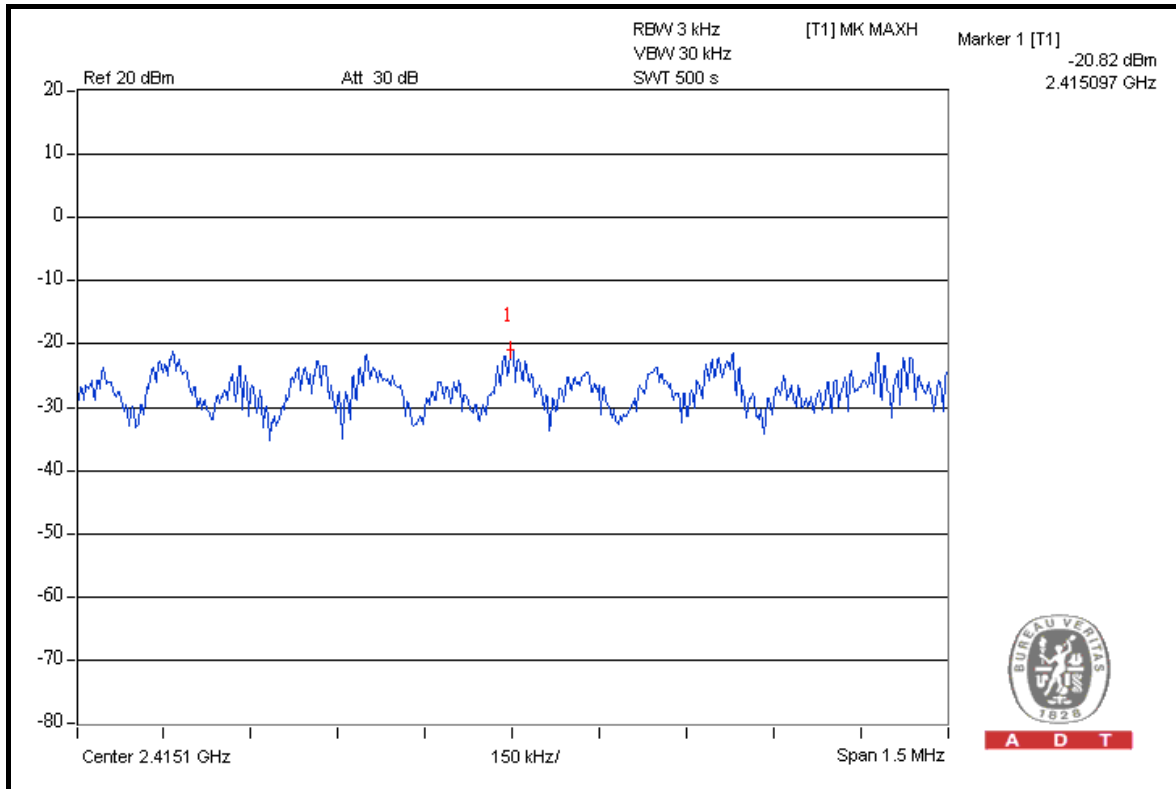



A D T

### CH 4

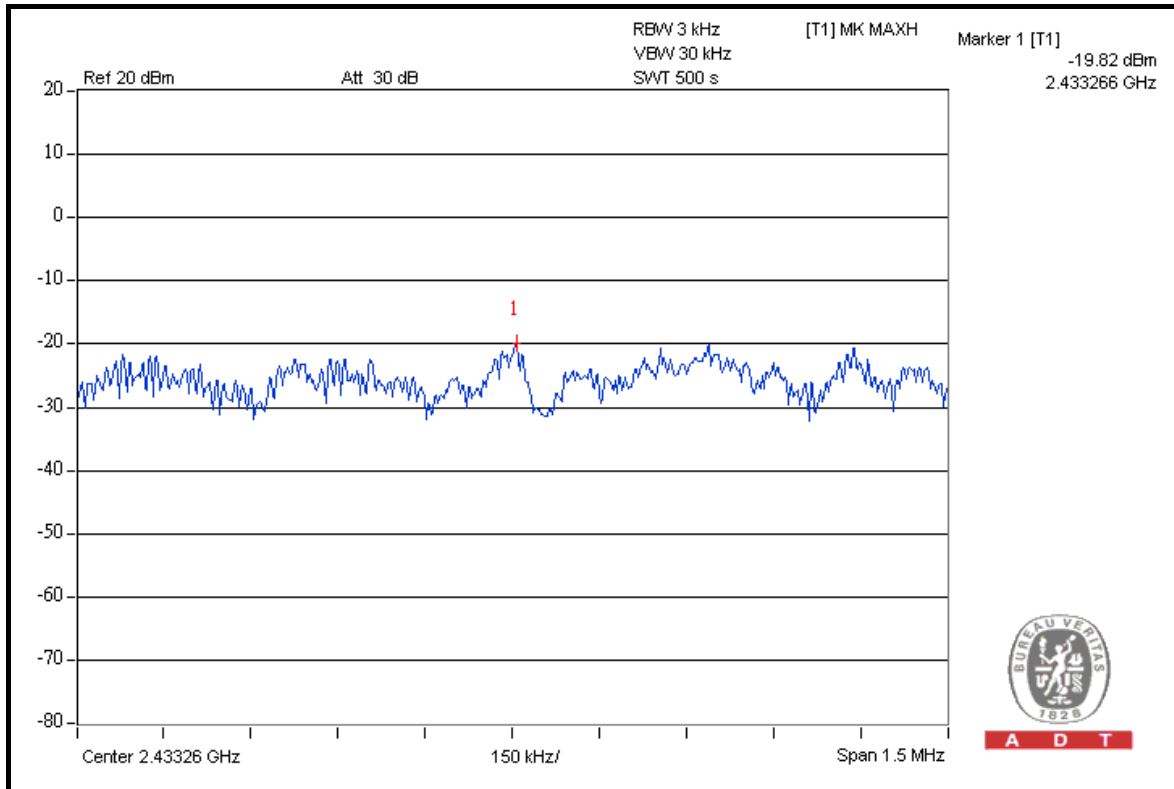

A D T

### CH 7

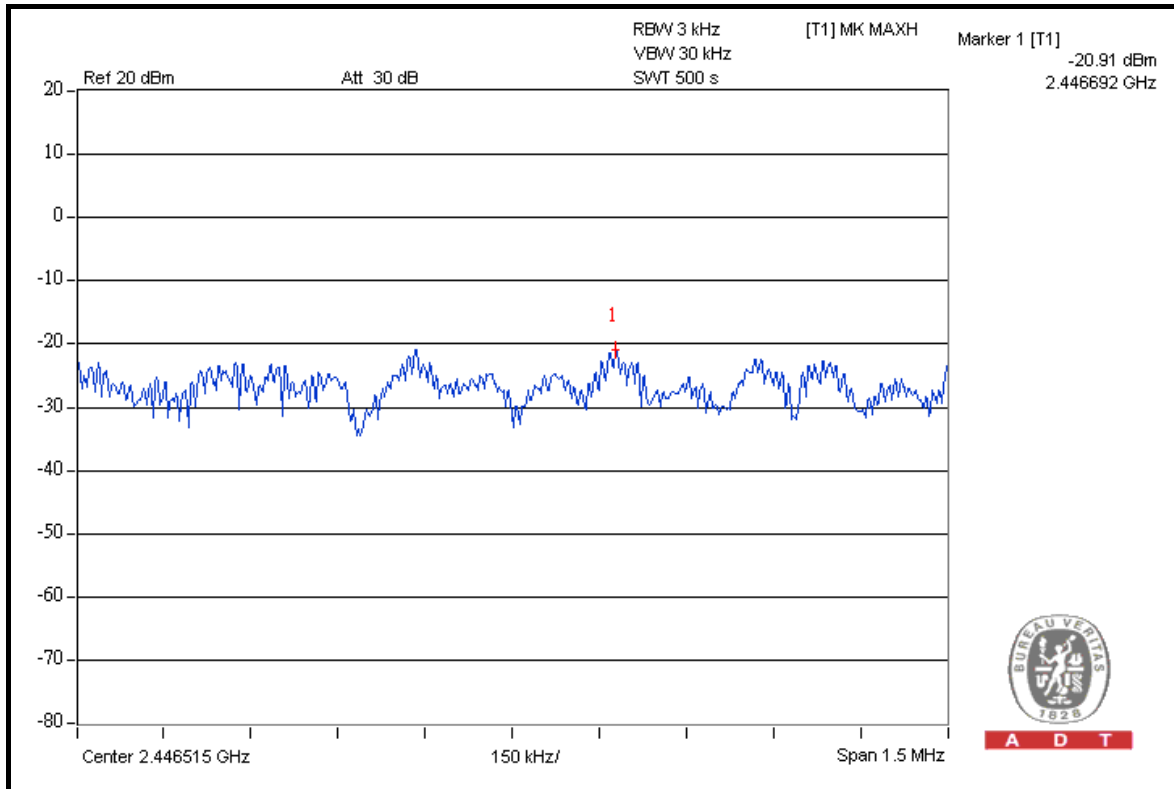

A D T



ADT

## 4.6 BAND EDGES MEASUREMENT

### 4.6.1 LIMITS OF BAND EDGES MEASUREMENT

Below -20dB of the highest emission level of operating band (in 100kHz Resolution Bandwidth).

### 4.6.2 TEST INSTRUMENTS

DESCRIPTION & MANUFACTURER	MODEL NO.	SERIAL NO.	DATE OF CALIBRATION	DUE DATE OF CALIBRATION
<b>FOR CONDUCTED MEASUREMENT</b>				
Spectrum Analyzer ROHDE & SCHWARZ	FSP40	100041	May 13, 2009	May 12, 2010
<b>FOR RADIATED MEASUREMENT</b>				
Test Receiver ROHDE & SCHWARZ	ESI7	838496/016	Dec. 29, 2008	Dec. 28, 2009
Spectrum Analyzer ROHDE & SCHWARZ	FSP40	100039	Dec. 08, 2008	Dec. 07, 2009
BILOG Antenna SCHWARZBECK	VULB9168	9168-155	Apr. 29, 2009	Apr. 28, 2010
HORN Antenna SCHWARZBECK	BBHA 9120D	9120D-408	Dec. 29, 2008	Dec. 28, 2009
HORN Antenna SCHWARZBECK	BBHA 9170	BBHA9170242	Jan. 06, 2009	Jan. 05, 2010
Preamplifier Agilent	8449B	3008A01960	Nov. 03, 2008	Nov. 02, 2009
Preamplifier Agilent	8447D	2944A10631	Nov. 03, 2008	Nov. 02, 2009
RF signal cable HUBER+SUHNNER	SUCOFLEX 104	274041/4	Aug. 21, 2008	Aug. 20, 2009
RF signal cable HUBER+SUHNNER	SUCOFLEX 104	283397/4	Aug. 21, 2008	Aug. 20, 2009
Software ADT.	ADT_Radiated_ V7.6.15.9.2	NA	NA	NA
Antenna Tower inn-co GmbH	MA 4000	010303	NA	NA
Antenna Tower Controller inn-co GmbH	CO2000	019303	NA	NA
Turn Table ADT.	TT100.	TT93021704	NA	NA
Turn Table Controller ADT.	SC100.	SC93021704	NA	NA

**NOTE:** The calibration interval of the above test instruments is 12 months and the calibrations are traceable to NML/ROC and NIST/USA.

### 4.6.3 TEST PROCEDURE

#### FOR CONDUCTED MEASUREMENT

The transmitter output was connected to the spectrum analyzer via a low loss cable. Set both RBW and VBW of spectrum analyzer to 100kHz and 300kHz with suitable frequency span including 100MHz bandwidth from band edge. The band edges was measured and recorded.

The spectrum plots (Peak RBW = 100kHz, VBW = 300kHz; Average RBW = 1MHz, VBW = 10Hz) are attached on the following pages.

#### FOR RADIATED MEASUREMENT

- a. The EUT was placed on the top of a rotating table 0.8 meters above the ground at a 3 meter semi-anechoic chamber. The table was rotated 360 degrees to determine the position of the highest radiation.
- b. The EUT was set 3 meters away from the interference-receiving antenna, which was mounted on the top of a variable-height antenna tower.
- c. The antenna is a broadband antenna, and its height is varied from one meter to four meters above the ground to determine the maximum value of the field strength. Both horizontal and vertical polarizations of the antenna are set to make the measurement.
- d. For each suspected emission, the EUT was arranged to its worst case and then the antenna was tuned to heights from 1 meter to 4 meters and the rotatable table was turned from 0 degrees to 360 degrees to find the maximum reading.
- e. Set both RBW and VBW of spectrum analyzer to 100kHz and 300kHz with suitable frequency span including 100MHz bandwidth from band edge. The band edges was measured and recorded.

The spectrum plots (Peak RBW = 100kHz, VBW = 300kHz) are attached on the following pages.

**NOTE:** The resolution bandwidth of test receiver/spectrum analyzer is 1MHz and the video bandwidth is 10Hz for Average detection (AV) at frequency above 1GHz.

### 4.6.4 DEVIATION FROM TEST STANDARD

No deviation.

### 4.6.5 EUT OPERATING CONDITION

Same as Item 4.3.6.

#### 4.6.6 TEST RESULTS

The spectrum plots are attached on the following pages. D1 line indicates the highest level, and D2 line indicates the 20dB offset below D1. It shows compliance with the requirement in part 15.247(d).

#### 802.11b DSSS MODULATION

**NOTE 1:** The band edge emission plot on the next page shows 52.60dBc between carrier maximum power and local maximum emission in restrict band (2.3584GHz). The emission of carrier strength list in the test result of channel 1 at the item 4.1.7 is 110.05dBuV/m (Peak), so the maximum field strength in restrict band is  $110.05 - 52.60 = 57.45$ dBuV/m which is under 74dBuV/m limit.

The band edge emission plot of on the next page shows 61.80dBc between carrier maximum power and local maximum emission in restrict band (2.3870GHz). The emission of carrier strength list in the test result of channel 1 at the item 4.1.7 is 105.26dBuV/m (Average), so the maximum field strength in restrict band is  $105.26 - 61.80 = 43.46$ dBuV/m which is under 54dBuV/m limit.

**NOTE 2:** The band edge emission plot on the next second page shows 52.32dBc between carrier maximum power and local maximum emission in restrict band (2.4996GHz). The emission of carrier strength list in the test result of channel 11 at the item 4.1.7 is 110.01dBuV/m (Peak), so the maximum field strength in restrict band is  $110.01 - 52.32 = 57.69$ dBuV/m which is under 74dBuV/m limit.

The band edge emission plot on the next third page shows 58.98dBc between carrier maximum power and local maximum emission in restrict band (2.4835GHz). The emission of carrier strength list in the test result of channel 11 at the item 4.1.7 is 105.02dBuV/m (Average), so the maximum field strength in restrict band is  $105.02 - 58.98 = 46.04$ dBuV/m which is under 54dBuV/m limit.



A D T

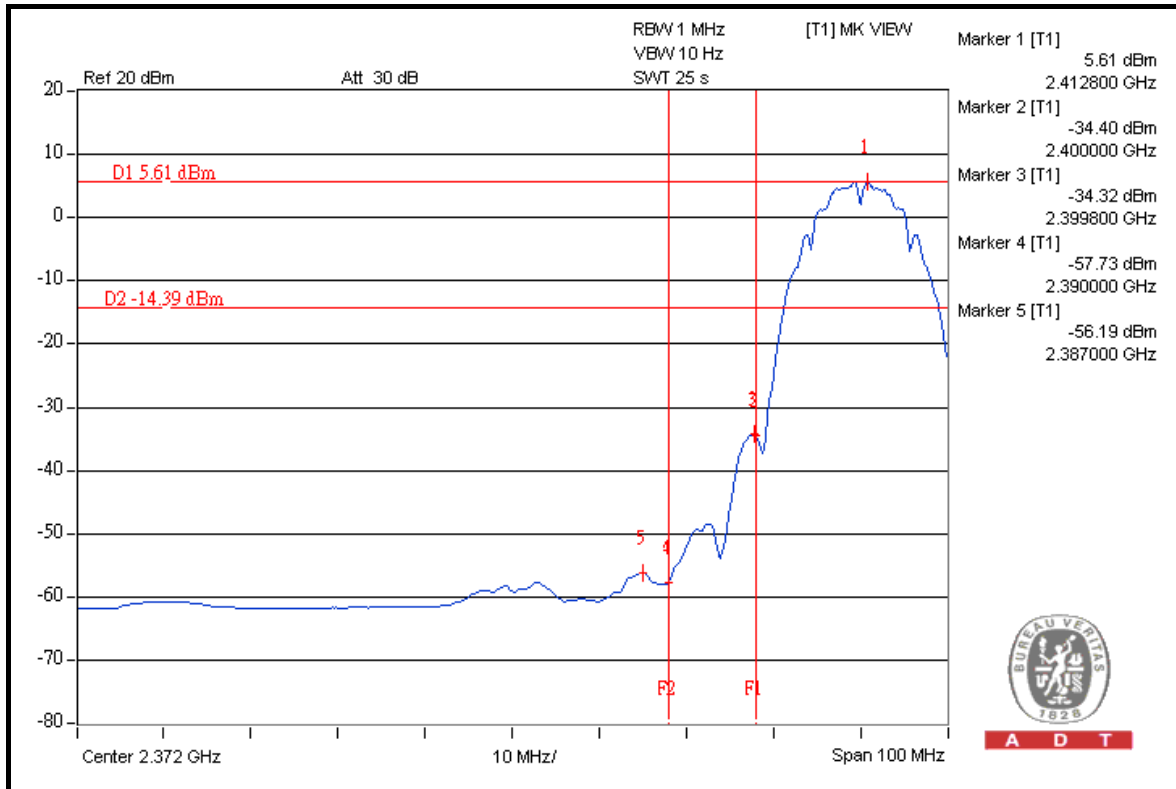
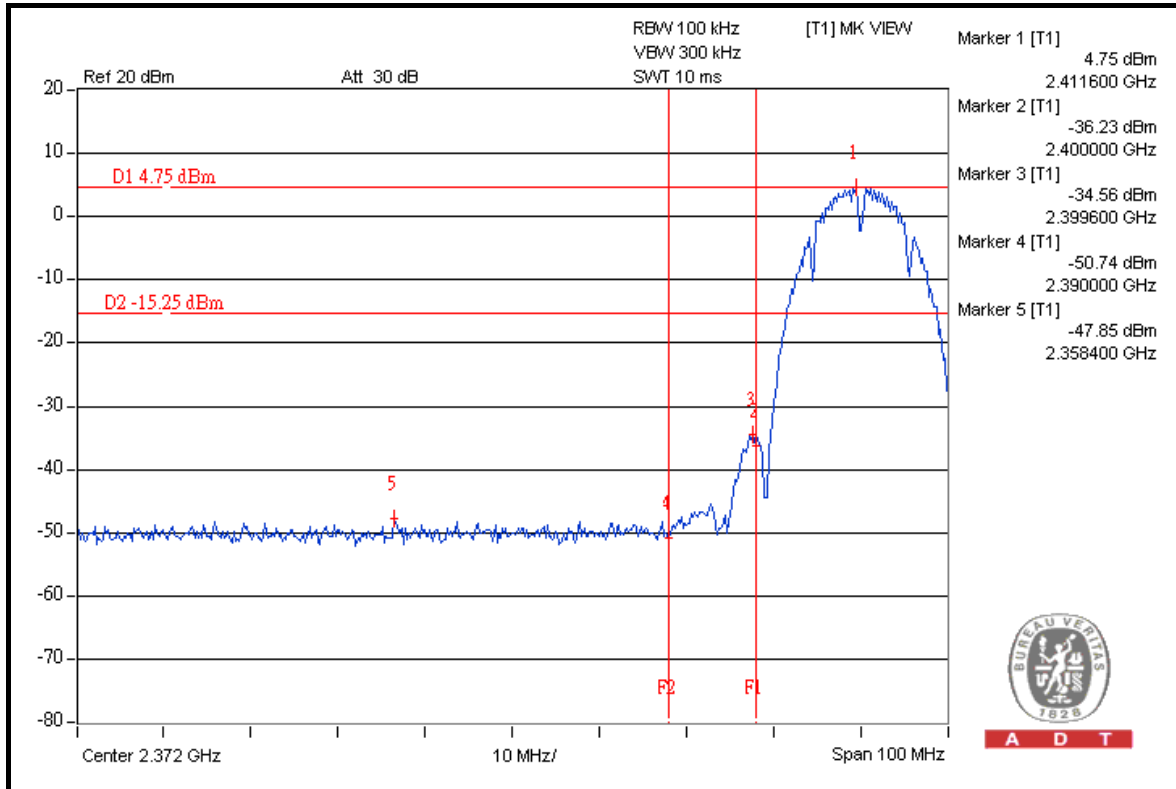





A D T

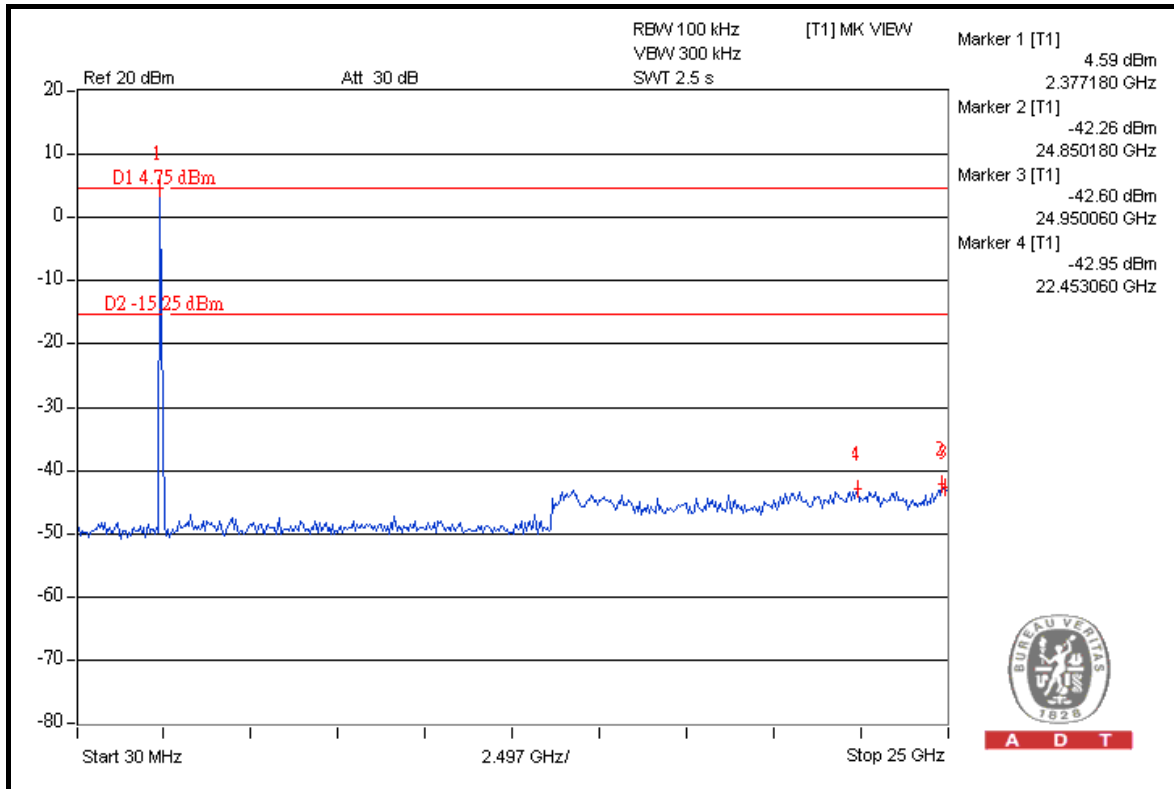

A D T

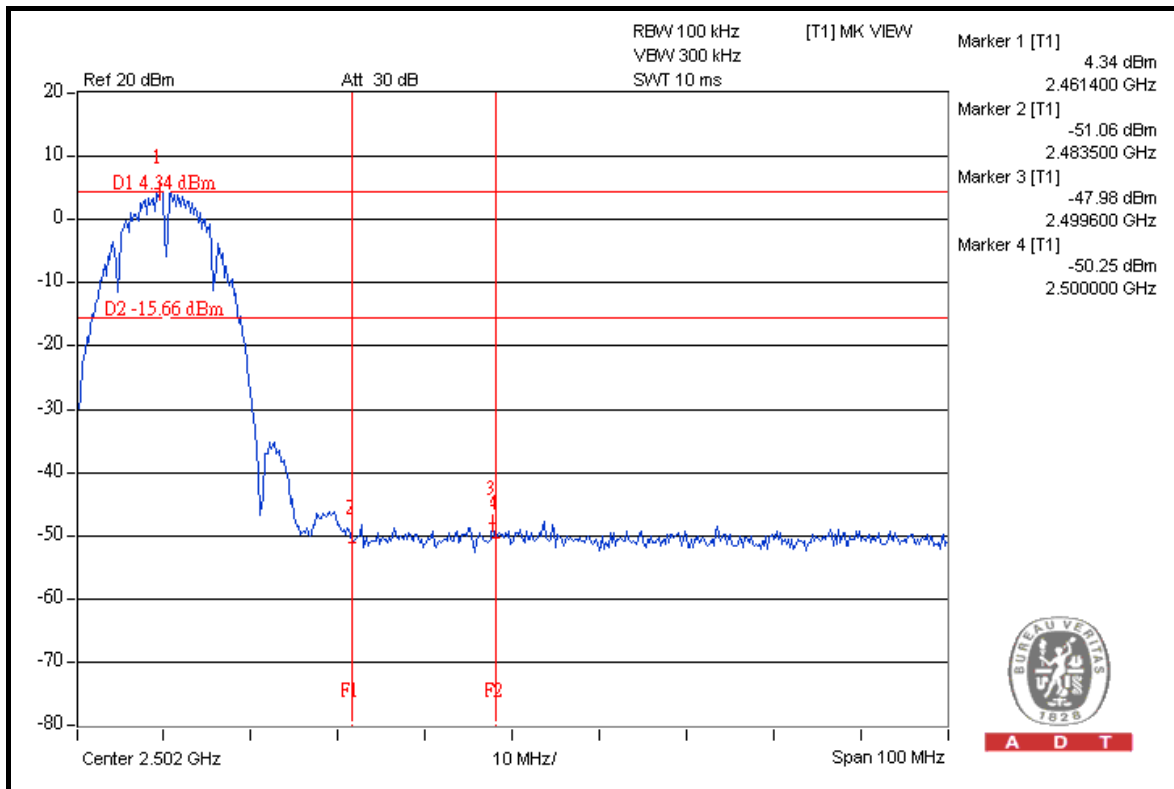

A D T



A D T

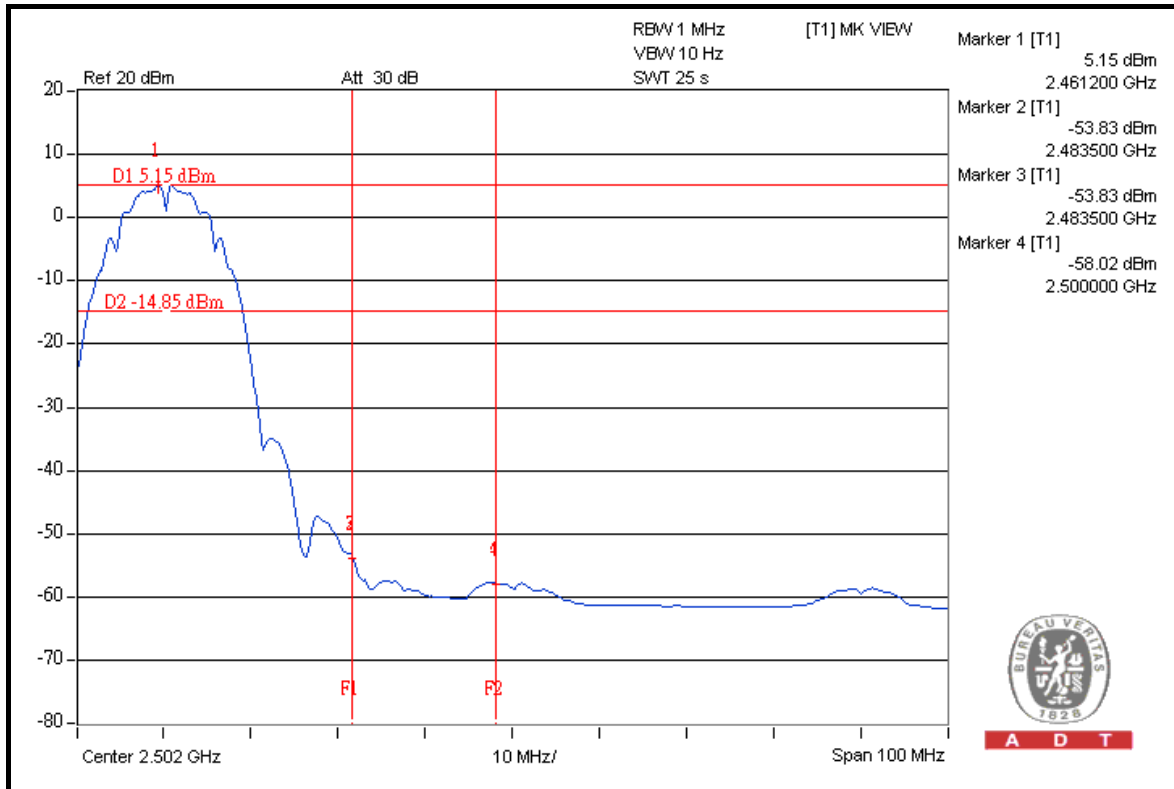

A D T

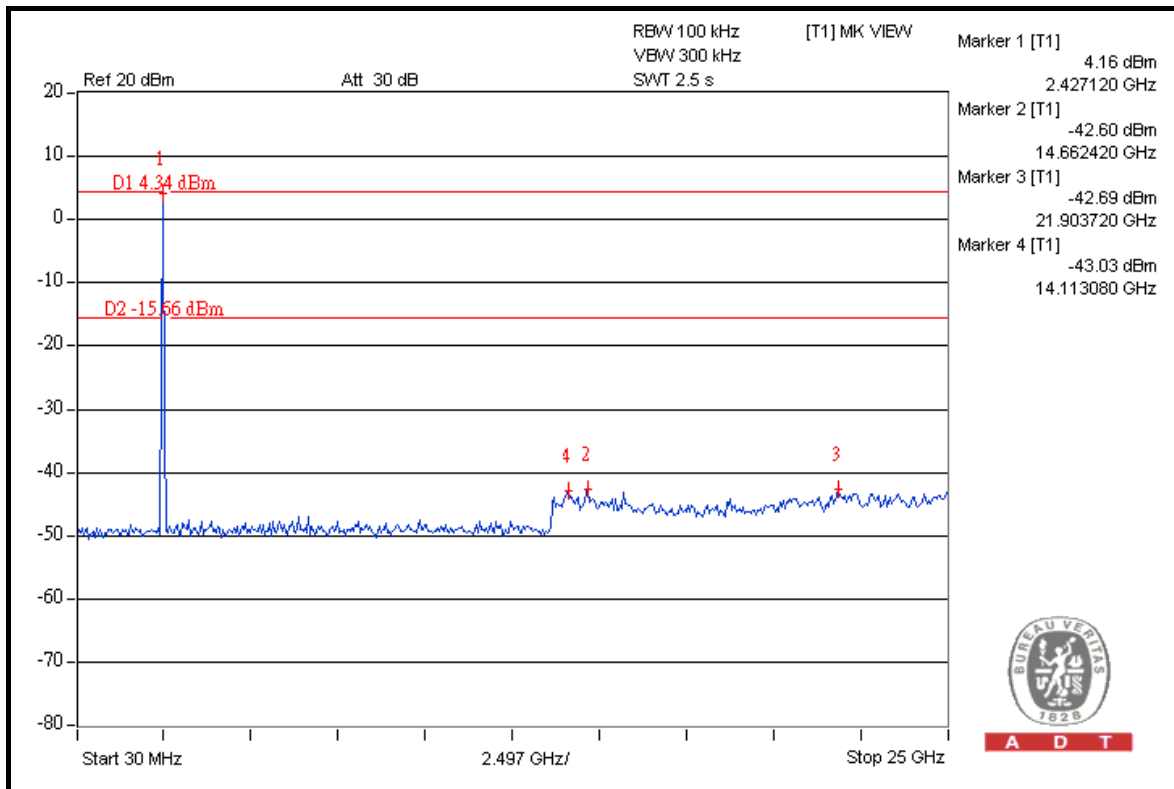

A D T



## 802.11g OFDM MODULATION

**NOTE 1:** The band edge emission plot on the next page shows 45.47dBc between carrier maximum power and local maximum emission in restrict band (2.3330GHz). The emission of carrier strength list in the test result of channel 1 at the item 4.1.7 is 107.19dBuV/m (Peak), so the maximum field strength in restrict band is  $107.19 - 45.47 = 61.72$ dBuV/m which is under 74dBuV/m limit.

The band edge emission plot of on the next page shows 54.76dBc between carrier maximum power and local maximum emission in restrict band (2.3384GHz). The emission of carrier strength list in the test result of channel 1 at the item 4.1.7 is 97.05dBuV/m (Average), so the maximum field strength in restrict band is  $97.05 - 54.76 = 42.29$ dBuV/m which is under 54dBuV/m limit.

**NOTE 2:** The band edge emission plot on the next second page shows 46.63dBc between carrier maximum power and local maximum emission in restrict band (2.4842GHz). The emission of carrier strength list in the test result of channel 11 at the item 4.1.7 is 107.08dBuV/m (Peak), so the maximum field strength in restrict band is  $107.08 - 46.63 = 60.45$ dBuV/m which is under 74dBuV/m limit.

The band edge emission plot on the next third page shows 54.37dBc between carrier maximum power and local maximum emission in restrict band (2.4835GHz). The emission of carrier strength list in the test result of channel 11 at the item 4.1.7 is 96.91dBuV/m (Average), so the maximum field strength in restrict band is  $96.91 - 54.37 = 42.54$ dBuV/m which is under 54dBuV/m limit.



A D T

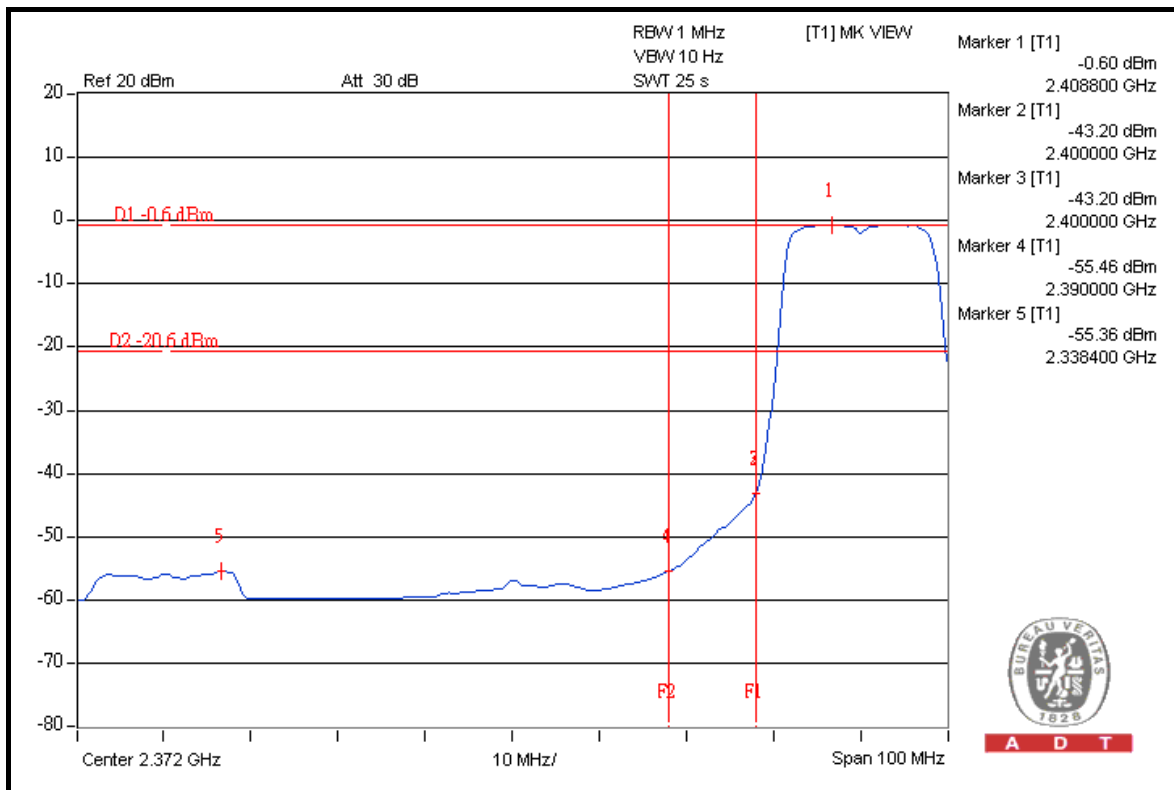
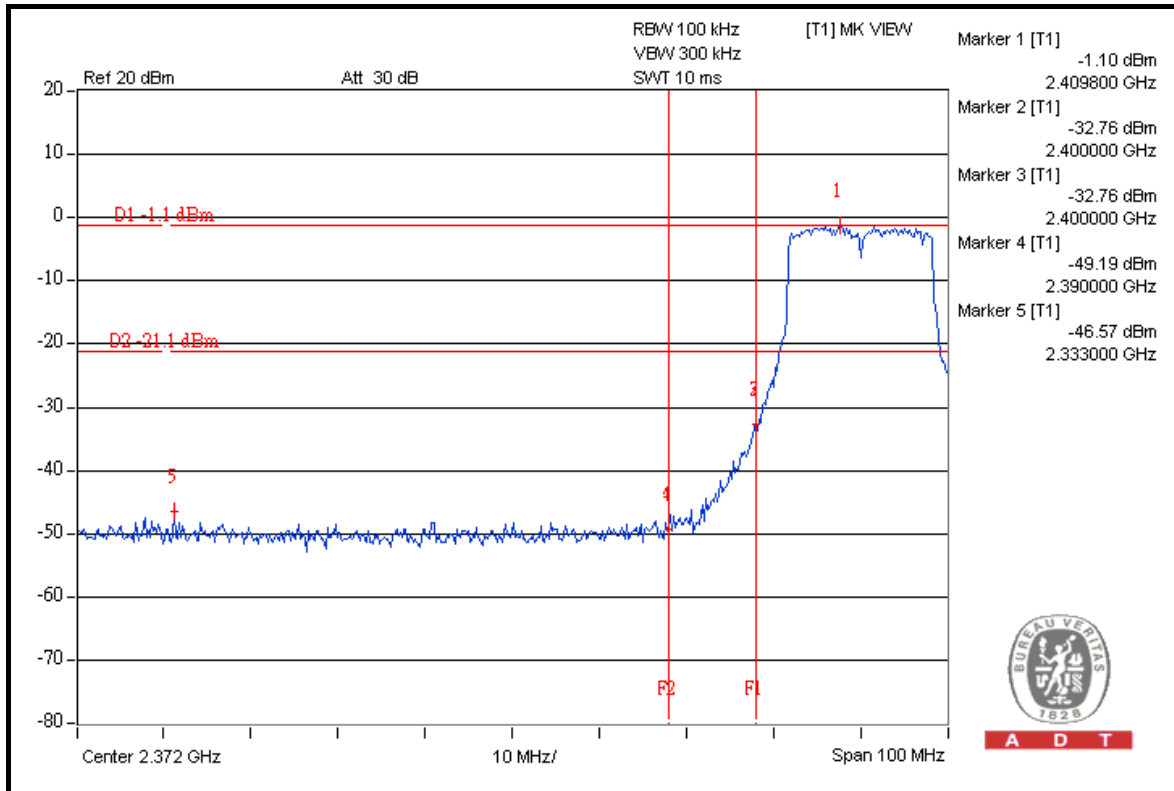



A D T

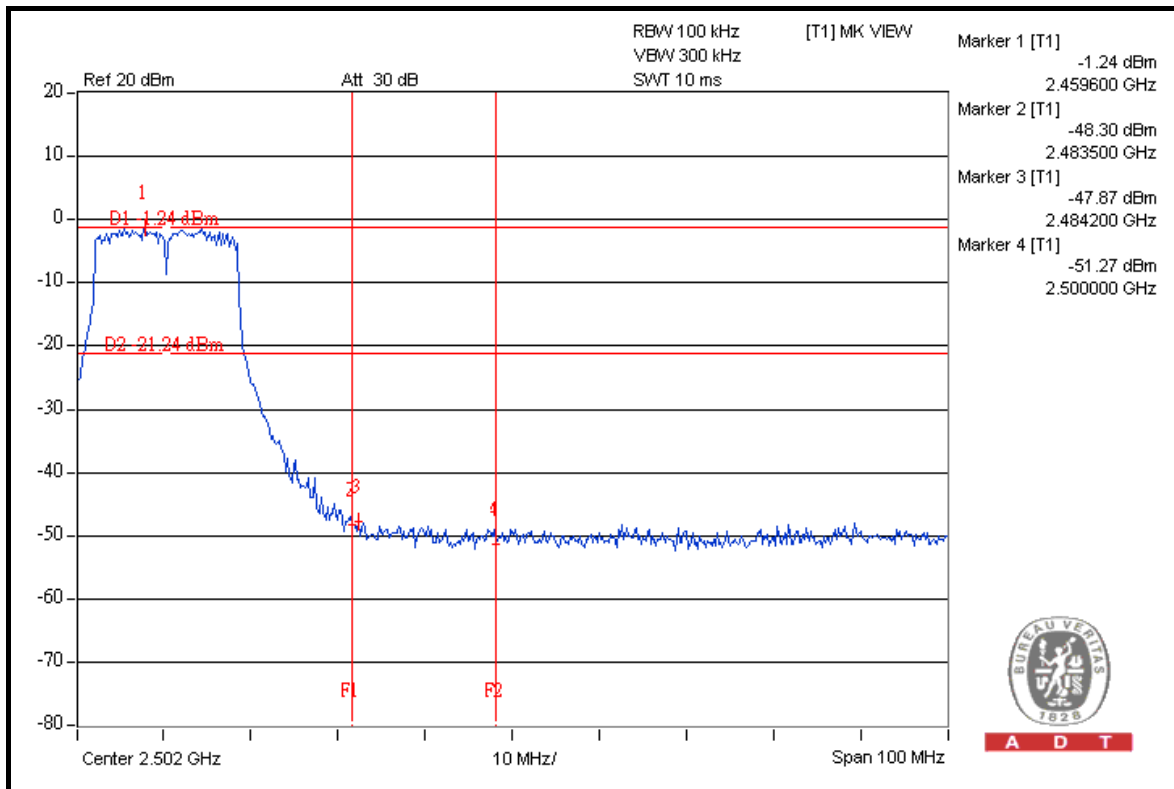
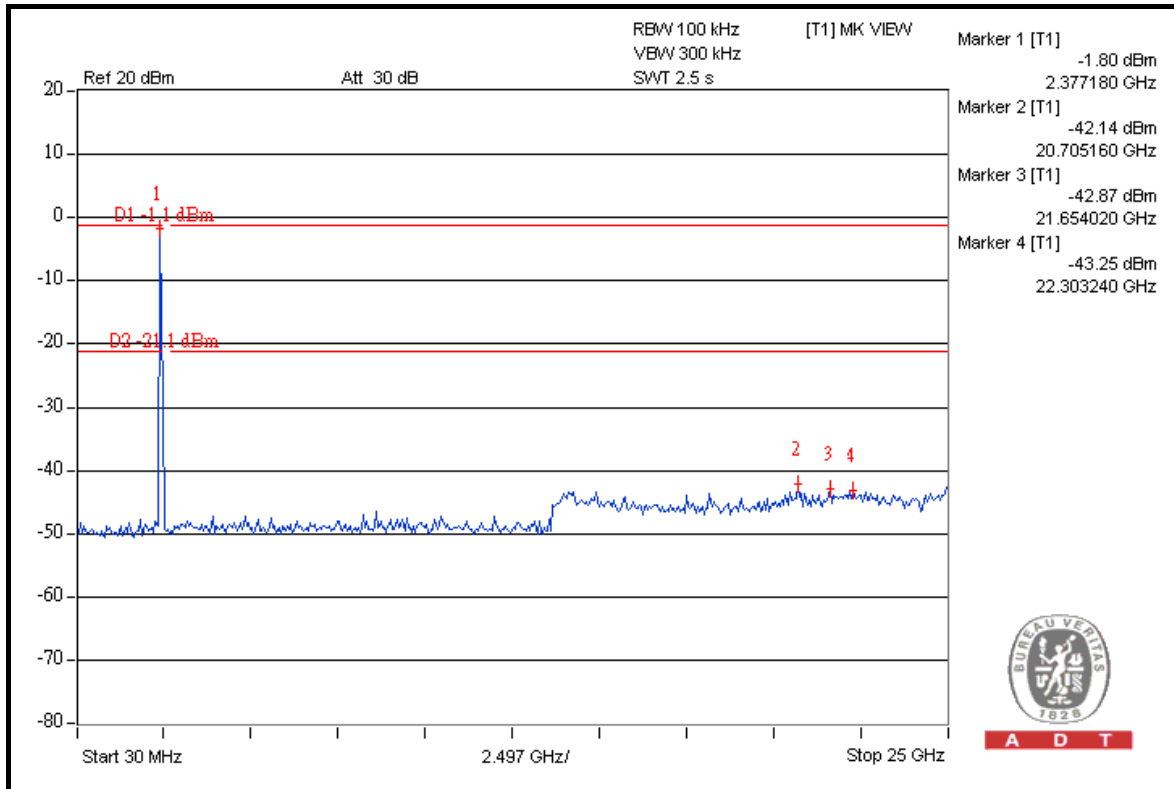



A D T

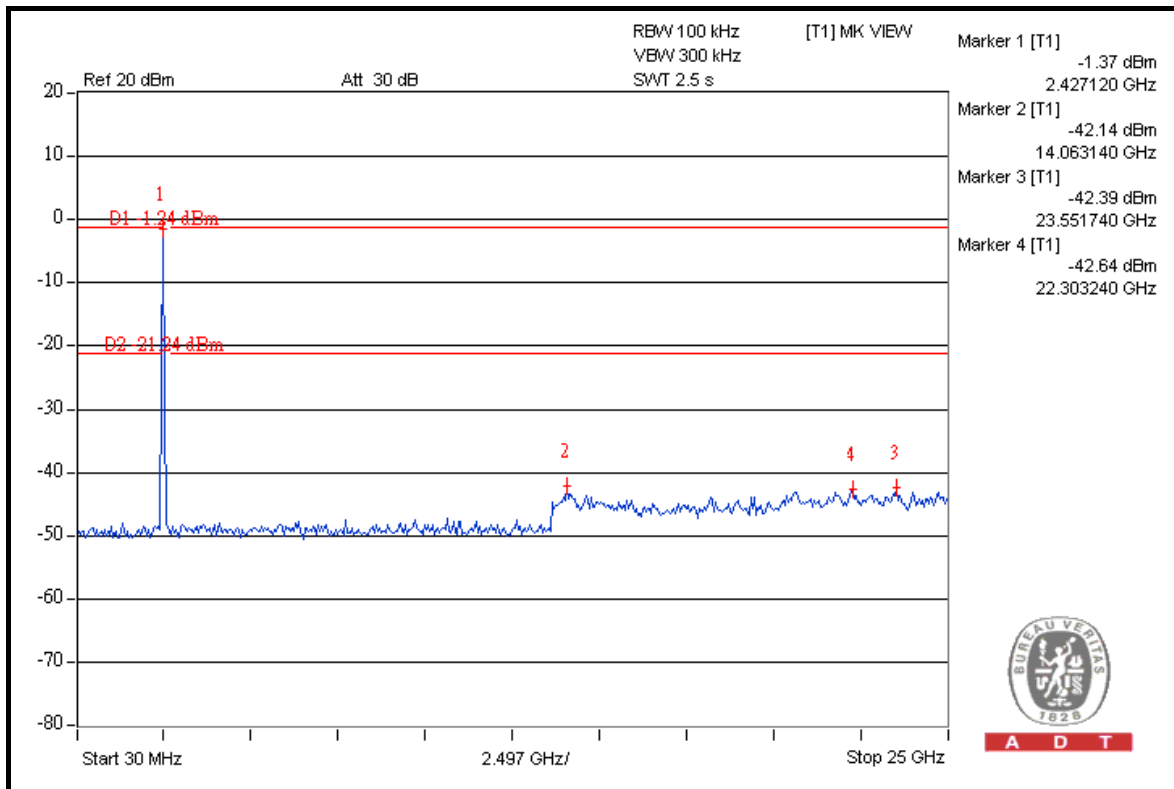
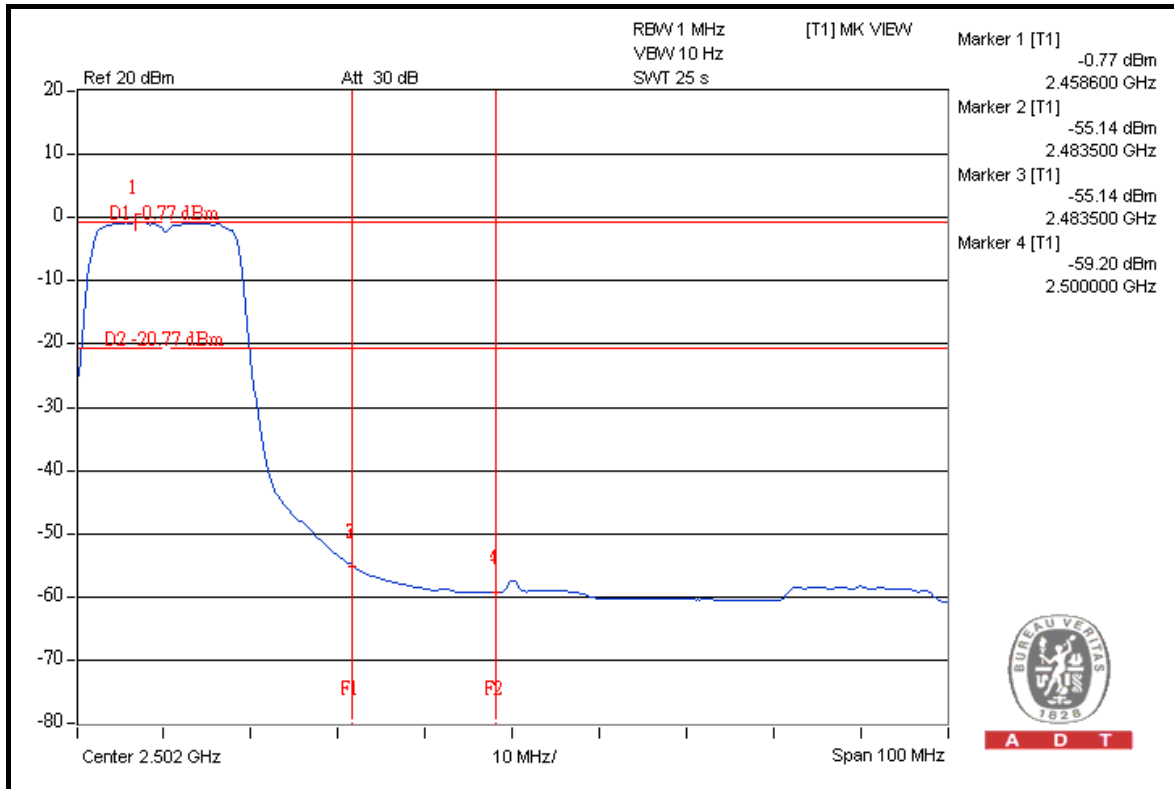



## DRAFT 802.11n (20MHz) OFDM MODULATION

**NOTE 1:** The band edge emission plot on the next page shows 44.17dBc between carrier maximum power and local maximum emission in restrict band (2.3830GHz). The emission of carrier strength list in the test result of channel 1 at the item 4.1.7 is 107.34dBuV/m (Peak), so the maximum field strength in restrict band is  $107.34 - 44.17 = 63.17$ dBuV/m which is under 74dBuV/m limit.

The band edge emission plot of on the next page shows 52.14dBc between carrier maximum power and local maximum emission in restrict band (2.3900GHz). The emission of carrier strength list in the test result of channel 1 at the item 4.1.7 is 96.62dBuV/m (Average), so the maximum field strength in restrict band is  $96.62 - 52.14 = 44.48$ dBuV/m which is under 54dBuV/m limit.

**NOTE 2:** The band edge emission plot on the next second page shows 45.53dBc between carrier maximum power and local maximum emission in restrict band (2.4934GHz). The emission of carrier strength list in the test result of channel 11 at the item 4.1.7 is 106.62dBuV/m (Peak), so the maximum field strength in restrict band is  $106.62 - 45.53 = 61.09$ dBuV/m which is under 74dBuV/m limit.

The band edge emission plot on the next third page shows 53.95dBc between carrier maximum power and local maximum emission in restrict band (2.4835GHz). The emission of carrier strength list in the test result of channel 11 at the item 4.1.7 is 96.06dBuV/m (Average), so the maximum field strength in restrict band is  $96.06 - 53.95 = 42.11$ dBuV/m which is under 54dBuV/m limit.



A D T

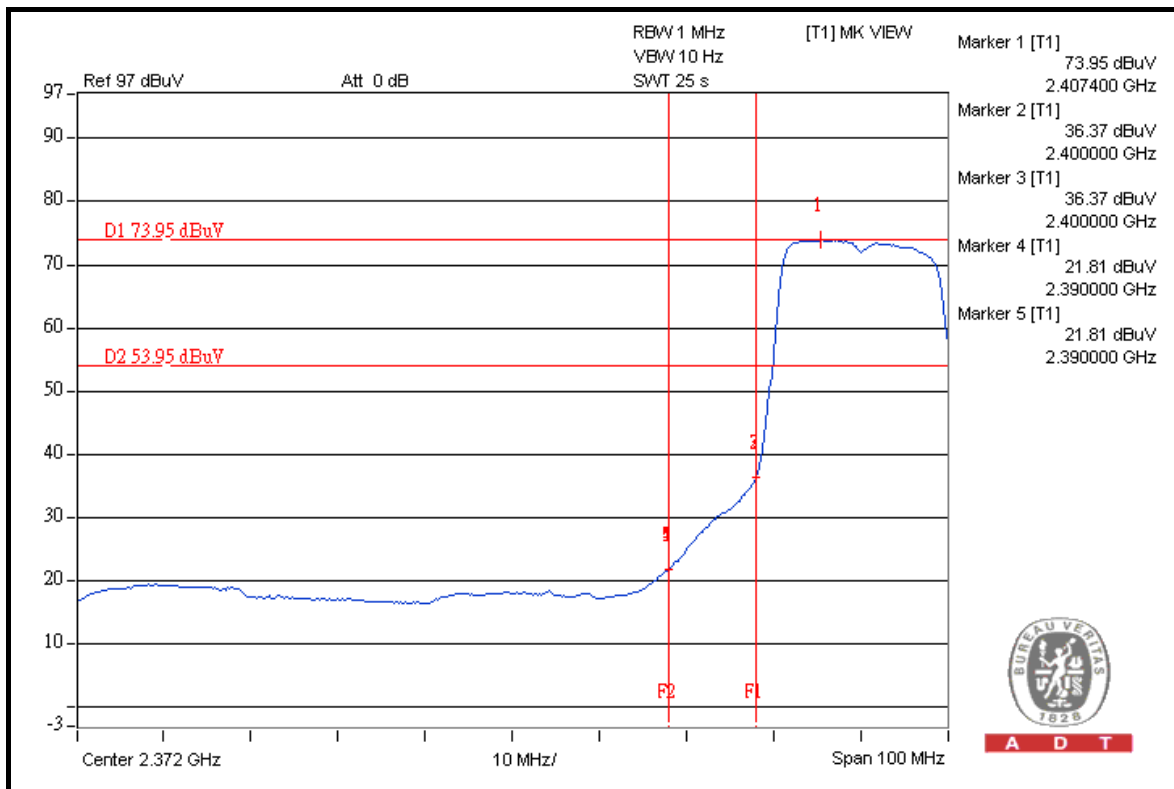
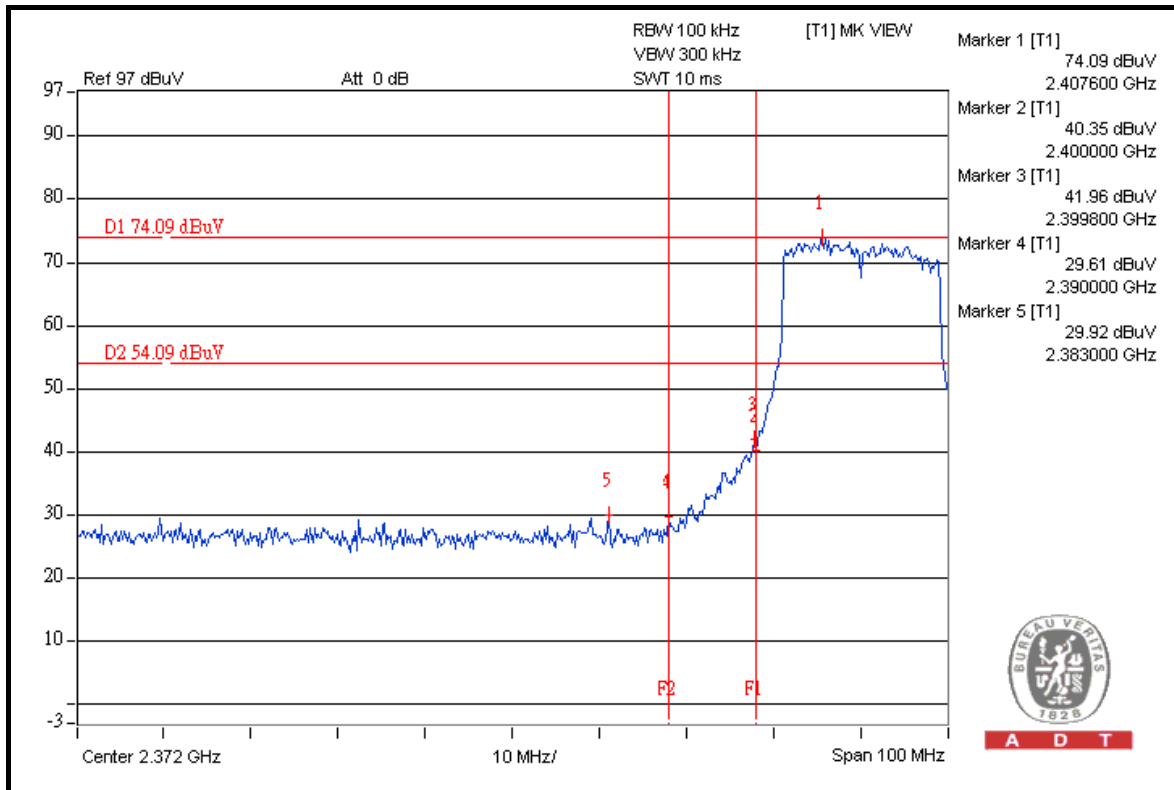





A D T

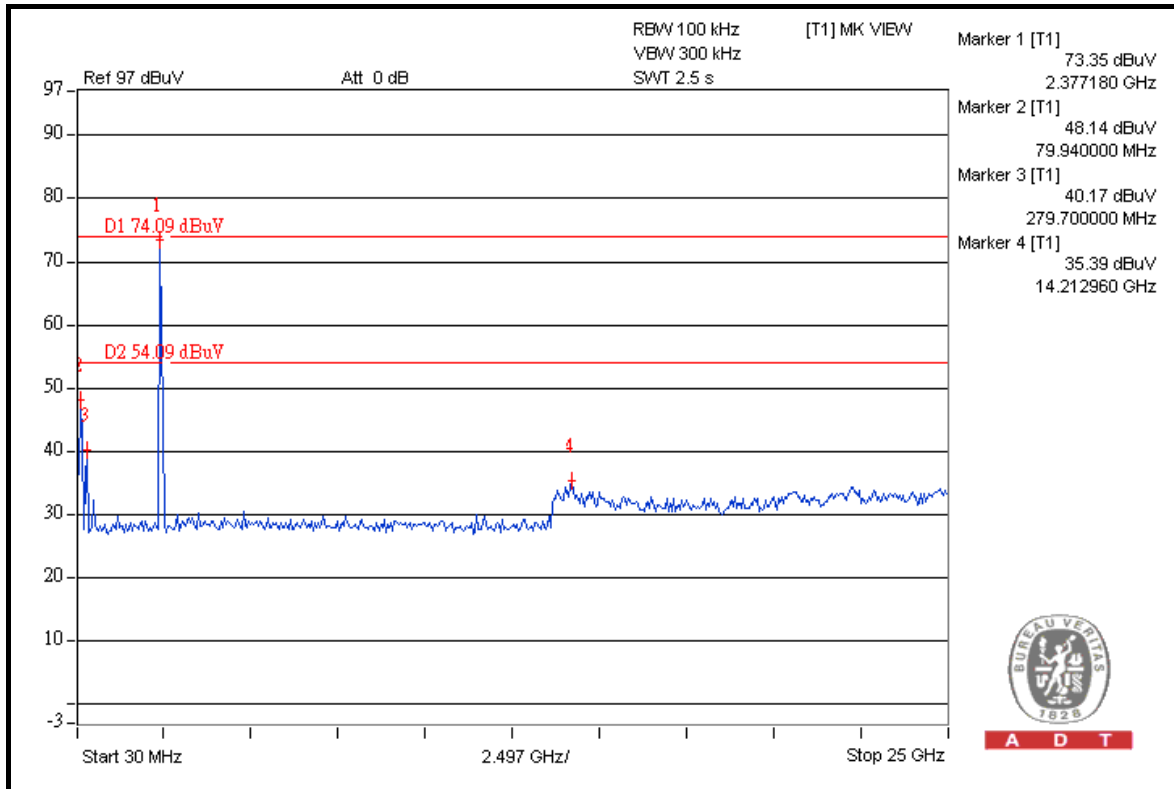

A D T

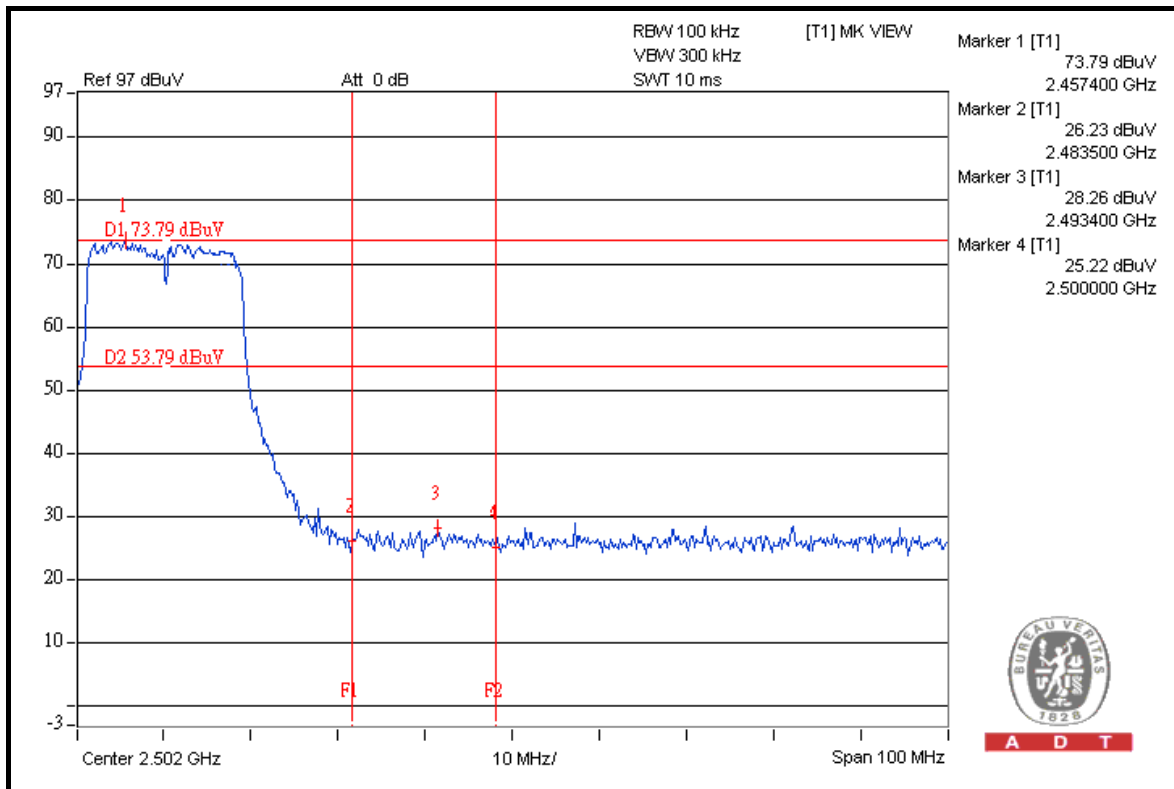

A D T



A D T

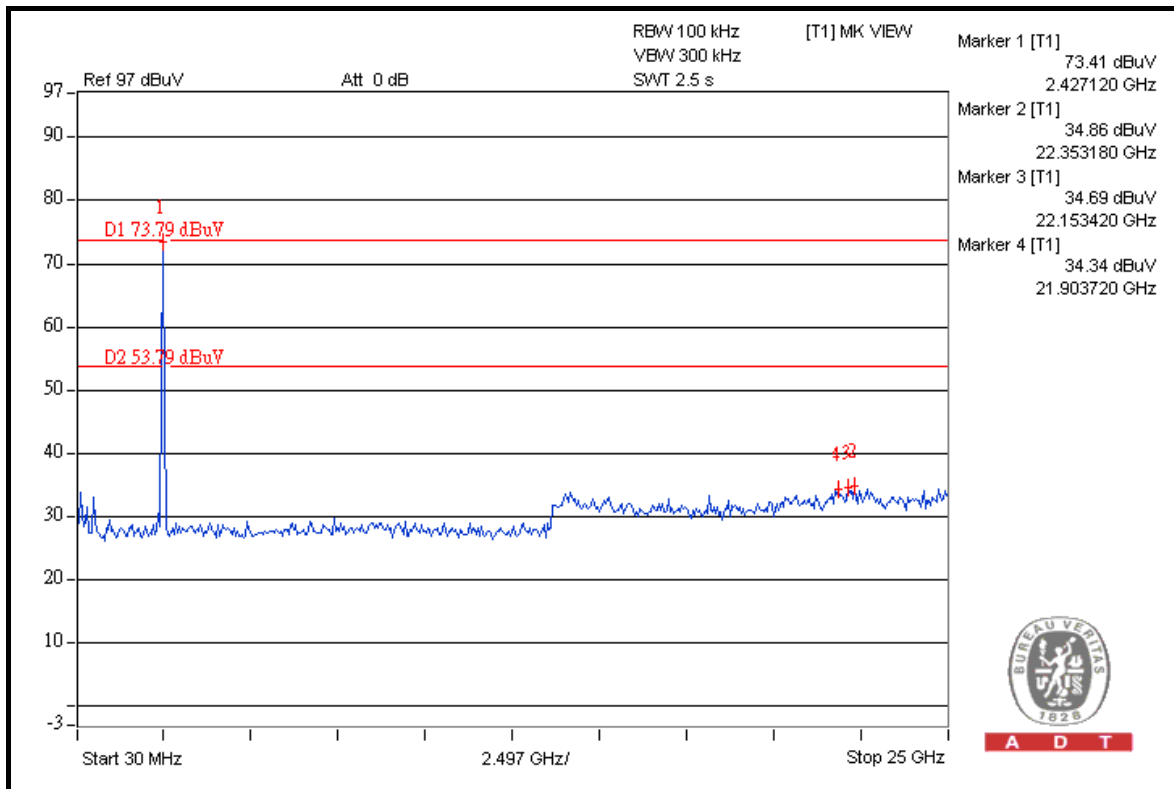
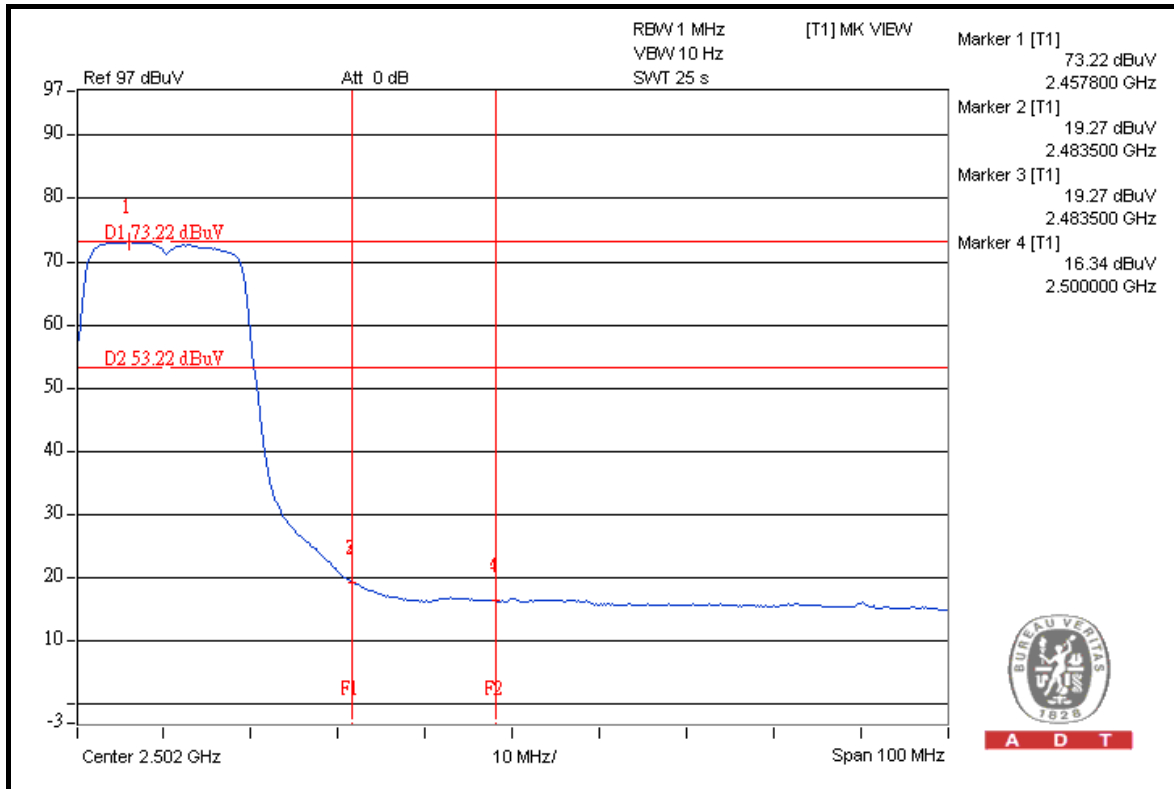



A D T

## DRAFT 802.11n (40MHz) OFDM MODULATION

**NOTE 1:** The band edge emission plot on the next page shows 41.06dBc between carrier maximum power and local maximum emission in restrict band (2.3864GHz). The emission of carrier strength list in the test result of channel 1 at the item 4.1.7 is 104.96dBuV/m (Peak), so the maximum field strength in restrict band is  $104.96 - 41.06 = 63.90$ dBuV/m which is under 74dBuV/m limit.

The band edge emission plot of on the next page shows 48.78dBc between carrier maximum power and local maximum emission in restrict band (2.3900GHz). The emission of carrier strength list in the test result of channel 1 at the item 4.1.7 is 94.33dBuV/m (Average), so the maximum field strength in restrict band is  $94.33 - 48.78 = 45.55$ dBuV/m which is under 54dBuV/m limit.

**NOTE 2:** The band edge emission plot on the next second page shows 40.55dBc between carrier maximum power and local maximum emission in restrict band (2.4852GHz). The emission of carrier strength list in the test result of channel 7 at the item 4.1.7 is 104.06dBuV/m (Peak), so the maximum field strength in restrict band is  $104.06 - 40.55 = 63.51$ dBuV/m which is under 74dBuV/m limit.

The band edge emission plot on the next third page shows 46.95dBc between carrier maximum power and local maximum emission in restrict band (2.4856GHz). The emission of carrier strength list in the test result of channel 7 at the item 4.1.7 is 94.07dBuV/m (Average), so the maximum field strength in restrict band is  $94.07 - 46.95 = 47.12$ dBuV/m which is under 54dBuV/m limit.



A D T

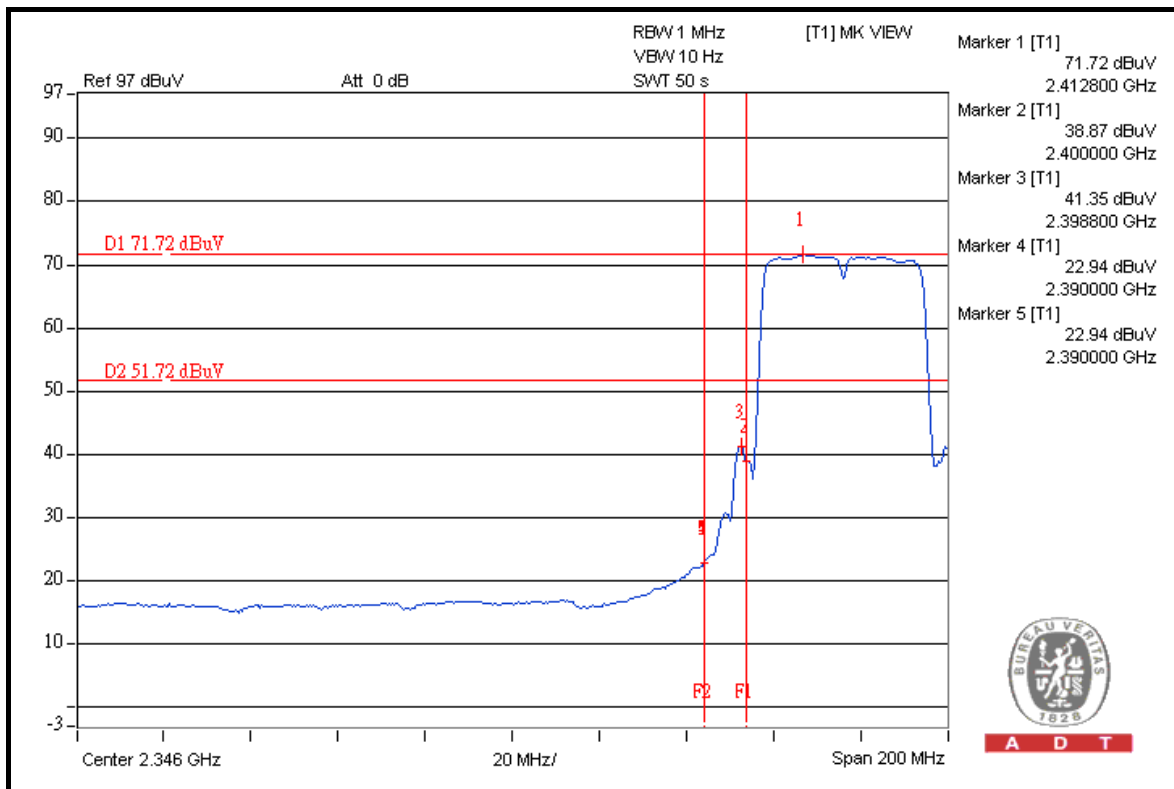
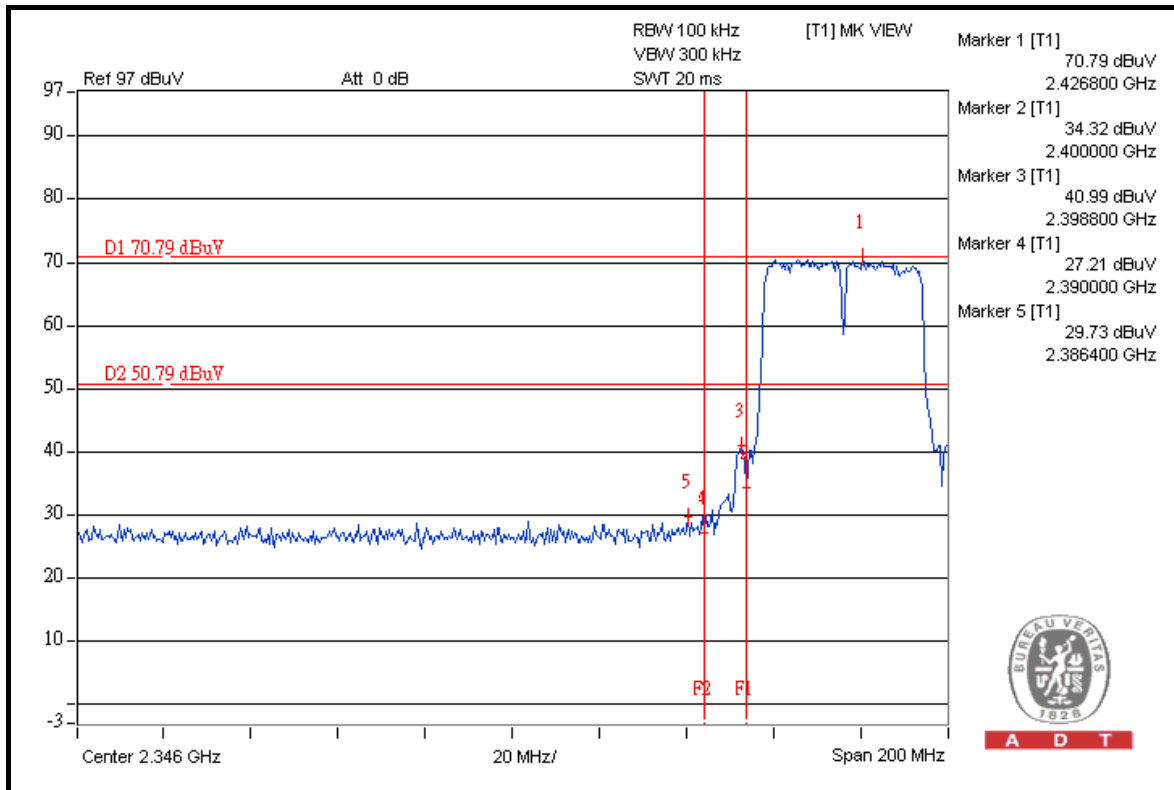



A D T

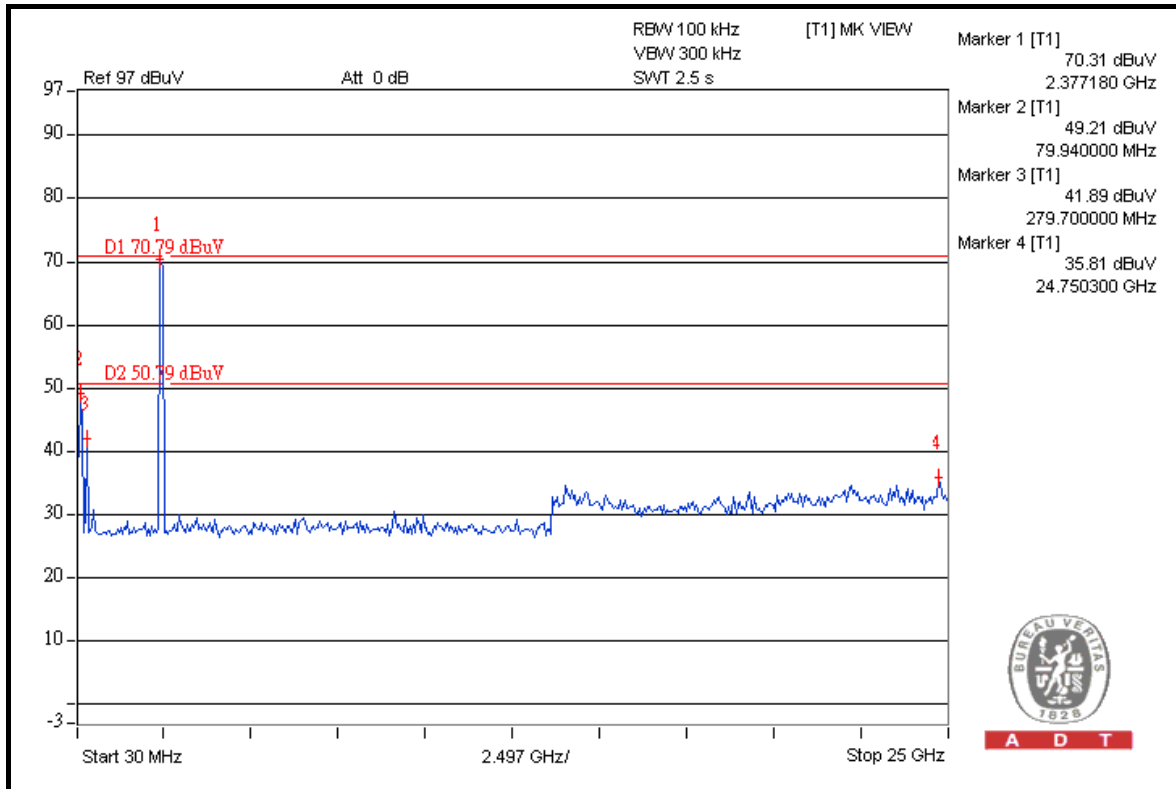

A D T

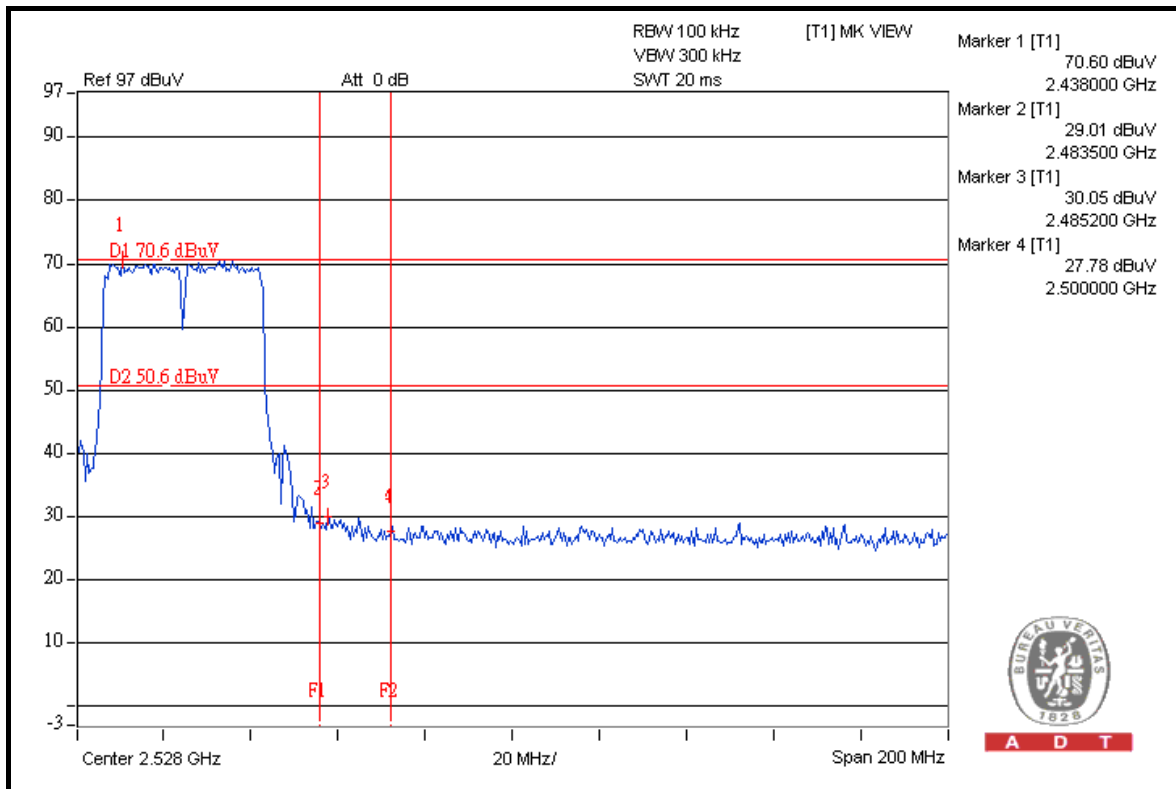

A D T



A D T

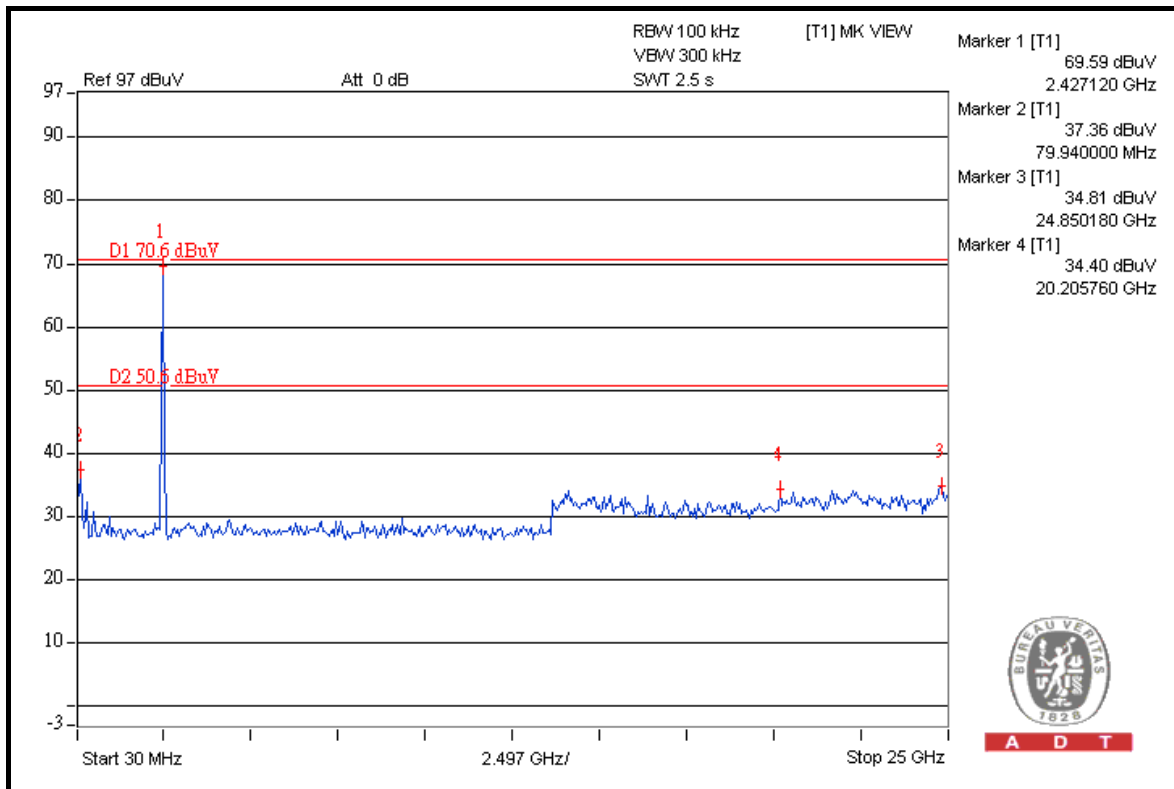
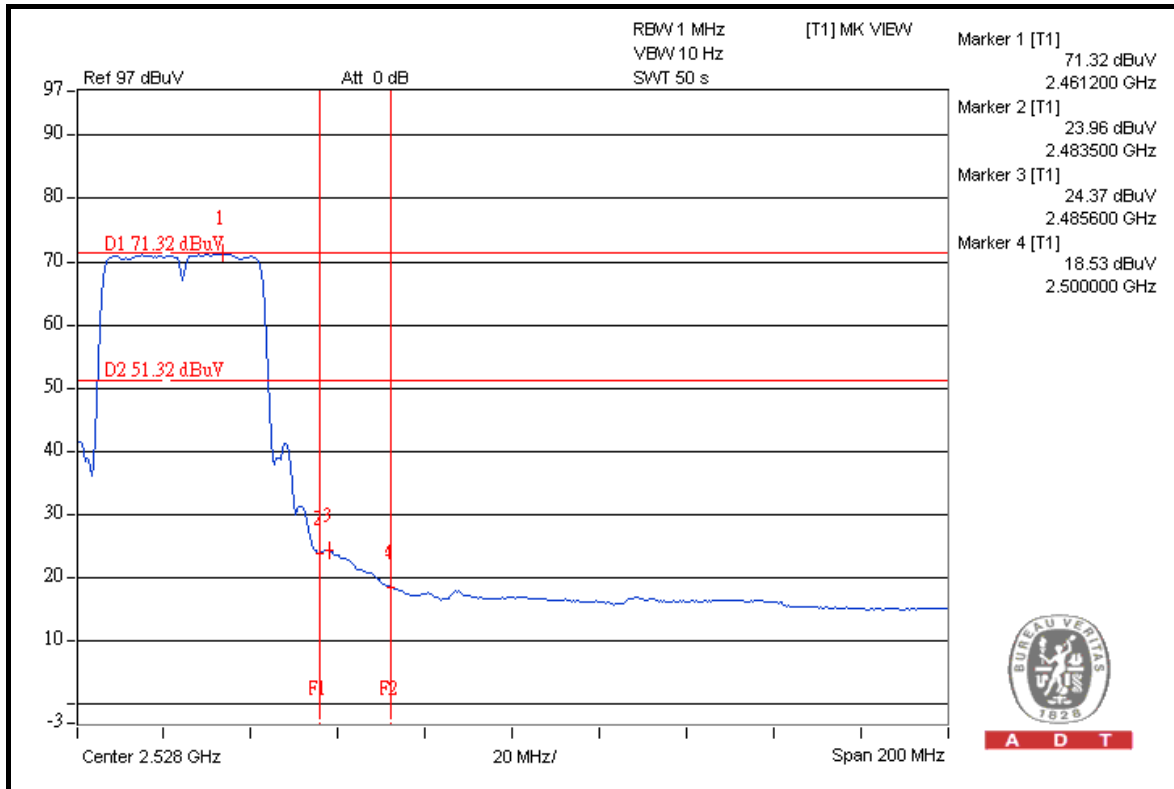



A D T

## 4.7 ANTENNA REQUIREMENT

### 4.7.1 STANDARD APPLICABLE

For intentional device, according to FCC 47 CFR Section 15.203, an intentional radiator shall be designed to ensure that no antenna other than that furnished by the responsible party shall be used with the device.

And according to FCC 47 CFR Section 15.247 (b), if transmitting antennas of directional gain greater than 6dBi are used, the power shall be reduced by the amount in dB that the directional gain of the antenna exceeds 6dBi.

### 4.7.2 ANTENNA CONNECTED CONSTRUCTION

The antenna used in this product is Printed antenna without connector. The maximum gain of the antenna is 2.77dBi.



A D T

## 5. PHOTOGRAPHS OF THE TEST CONFIGURATION

Please refer to the attached file (Test Setup Photo).





A D T

## 6. INFORMATION ON THE TESTING LABORATORIES

We, Bureau Veritas Consumer Products Services (H.K.) Ltd., Taoyuan Branch, were founded in 1988 to provide our best service in EMC, Radio, Telecom and Safety consultation. Our laboratories are accredited and approved by the following approval agencies according to ISO/IEC 17025.

<b>USA</b>	FCC, NVLAP
<b>Germany</b>	TUV Rheinland
<b>Japan</b>	VCCI
<b>Norway</b>	NEMKO
<b>Canada</b>	INDUSTRY CANADA, CSA
<b>R.O.C.</b>	TAF, BSMI, NCC
<b>Netherlands</b>	Telefication
<b>Singapore</b>	GOST-ASIA(MOU)
<b>Russia</b>	CERTIS(MOU)

Copies of accreditation certificates of our laboratories obtained from approval agencies can be downloaded from our web site:

[www.adt.com.tw/index.5/phtml](http://www.adt.com.tw/index.5/phtml). If you have any comments, please feel free to contact us at the following:

**Linko EMC/RF Lab:**  
Tel: 886-2-26052180  
Fax: 886-2-26051924

**Hsin Chu EMC/RF Lab:**  
Tel: 886-3-5935343  
Fax: 886-3-5935342

**Hwa Ya EMC/RF/Safety Telecom Lab:**  
Tel: 886-3-3183232  
Fax: 886-3-3185050

**Web Site:** [www.adt.com.tw](http://www.adt.com.tw)

The address and road map of all our labs can be found in our web site also.



A D T

## **7. APPENDIX A - MODIFICATIONS RECORDERS FOR ENGINEERING CHANGES TO THE EUT BY THE LAB**

No any modifications are made to the EUT by the lab during the test.

**---END---**