



FCC TEST REPORT

According to

FCC Rules and Regulations

Part 15 Subpart E

Applicant	:	Netgear Inc.
Address	:	305 East Plumeria Drive San Jose, California 95134-1911
Equipment	:	Digital Entertainer Elite
Model No.	:	EVA9000
FCC ID	:	PY308200088
Trade Name	:	NETGEAR

Laboratory accreditation



- The test result refers exclusively to the test presented test model / sample.,
- The test result does not include DFS test for 5250 ~ 5350 MHz.
- Without written approval of **Cerpass Technology Corporation**. the test report shall not be reproduced except in full.
- The EUT is also considered as a kind of computer peripheral, because the connection to computer is necessary for typical use. It has been verified to comply with the requirements of FCC Part 15, Subpart B, Class B (DoC). The test report has been issued separately.



CONTENTS

1.	Report of Measurements and Examinations.....	5
1.1.	List of Measurements and Examinations	5
2.	Test Configuration of Equipment under Test.....	6
2.1.	Feature of Equipment under Test.....	6
2.2.	Carrier Frequency of Channels.....	7
2.3.	Test Mode and Test Software.....	8
2.4.	Description of Test System.....	8
2.5.	Connection Diagram of Test System.....	9
2.6.	General Information of Test.....	10
2.7.	History of this test report	11
3.	Antenna Requirements	12
3.1.	Standard Applicable	12
3.2.	Antenna Construction and Directional Gain.....	12
4.	Test of Conducted Emission	13
4.1.	Test Procedures	13
4.2.	Typical Test Setup Layout of Conducted Emission.....	14
4.3.	Conducted Emission Requirement	14
4.4.	Measurement Equipment.....	14
4.5.	Test Result and Data.....	15
4.6.	Test Photographs	21
5.	Test of Radiated Emission	22
5.1.	Test Procedures	22
5.2.	Typical Test Setup Layout of Radiated Emission.....	23
5.3.	Measurement Equipment.....	23
5.4.	Test Result of Radiated Emission	24
5.5.	Photographs of Radiated Emission Test.....	52
6.	Peak Transmit Power.....	53
6.1.	Test Procedure	53
6.2.	Test Setup Layout	53
6.3.	Measurement Equipment.....	53
6.4.	Test Result and Data.....	54
7.	Peak Power Excursion.....	71
7.1.	Test Procedure	71
7.2.	Test Setup Layout	71
7.3.	Measurement Equipment.....	71
7.4.	Test Result and Data.....	71
8.	Peak Power Spectral Density.....	80
8.1.	Test Procedure	80
8.2.	Test Setup Layout	80
8.3.	Measurement Equipment.....	80
8.4.	Test Result and Data.....	80
9.	Frequency Stability.....	89
9.1.	Test Procedure	89
9.2.	Test Setup Layout	89



9.3. Measurement Equipment.....89

9.4. Test Result and Data.....90

10. Band Edges Measurement91

10.1. Test Procedure.....91

10.2. Measurement Equipment.....91

10.3. Test Result and Data.....91

10.4. Restrict Band Emission Measurement Data95

11. Restricted Bands of Operation.....96

11.1. Labeling Requirement.....96

12. RF Exposure97

12.1. Limit for Maximum Permissible Exposure (MPE)97

12.2. MPE Calculations.....98

12.3. FCC Radiation Exposure Statement.....98

Appendix A. Photographs of EUT.....A1 ~ A9



CERTIFICATE OF COMPLIANCE

According to

FCC Rules and Regulations

Part 15 Subpart E

Applicant	:	Netgear Inc.
Address	:	305 East Plumeria Drive San Jose, California 95134-1911
Equipment	:	Digital Entertainer Elite
Model No.	:	EVA9000
FCC ID	:	PY308200088

I HEREBY CERTIFY THAT :

The measurements shown in this test report were made in accordance with the procedures given in **ANSI C63.4** The equipment was **passed** the test performed according to **FCC Rules and Regulations Part 15 Subpart E (2003)**.

The test was carried out on Nov. 13, 2008 at **CerpPASS Technology Corporation**.

Signature

Anson Chou /

EMC/RF B.U. Vice General Manager



1. Report of Measurements and Examinations

1.1. List of Measurements and Examinations

For Frequency 5.15GHz ~ 5.25GHZ

Applied Standard : FCC Part 15, Subpart E (Section 15.407)		
FCC Rule	Description of Test	Result
15.407(b)(5)	. Conducted Emission	Pass
15.407(b/1/2/3)(b)(5)	. Radiated Emission	Pass
15.407(a/1/2/3)	. Peak Transmit Power	Pass
15.407(a)(6)	. Peak Power Excursion	Pass
15.407(a/1/2/3)	. Peak Power Spectral Density	Pass
15.407(g)	. Frequency Stability	Pass



2. Test Configuration of Equipment under Test

2.1. Feature of Equipment under Test

Feature	Description
Data and routing protocols	TCP/IP, DHCP
Power adapter	<ul style="list-style-type: none"> • North America: 120V, 60 Hz, input • United Kingdom, Australia: 240V, 50 Hz, input • Europe: 230V, 50 Hz, input • Japan: 100V, 50/60 Hz, input • Maximum input current NA: 0.24A; UK; AU: 0.15A; EU: 0.15A; JP: 0.27A
Physical specifications	<ul style="list-style-type: none"> • Dimensions (H x W x D): 1.5 x 17 x 10 in. (38.1 x 431.8 x 254 mm) • Weight: 4.4 lbs (2.0 kg)
Environmental specifications	<ul style="list-style-type: none"> • Operating temperature: 32°–104° F (0°–40° C) • Operating humidity: 90% maximum relative humidity, noncondensing
Electromagnetic emissions	FCC Part 15 Class B, VCCI Class B, EN 55 022 (CISPR 22), Class B C-Tick N10947
Interface	LAN: 10BASE-T or 100BASE-Tx, RJ-45; WLAN: 802.11/b/g/n
Radio data rates	11a, 11b, 11g & 11n data rates (Auto Rate Sensing)
Frequency	2400 - 2483.5 MHz, 5150 - 5825MHz
Data encoding	Standards <ul style="list-style-type: none"> • IEEE 802.11n draft • IEEE 802.11b, IEEE 802.11g, IEEE 802.11n - 2.4 GHz • IEEE 802.11a, IEEE 802.11n - 5.0 GHz
Operating frequency ranges	<ul style="list-style-type: none"> • US: 2.4 GHz: 2400 - 2462 MHz 5 GHz: non-DFS 5150 - 5250 MHz and 5725 - 5875 MHz • EU: 2.4 GHz: 2400 - 2483.5 MHz 5 GHz: 5150-5250 MHz, 5250-5350 MHz, 5470-5725 MHz,
802.11 security	40-bit (also called 64-bit) and 128-bit WEP, WPA-PSK, WPA2-PSK
Data Rate	<ul style="list-style-type: none"> • 802.11b (11, 5.5, 2, 1 Mbps) • 802.11g (54, 48, 36, 24, 18, 12, 9, 6 Mbps) • 802.11a (54, 48, 36, 24, 18, 12, 9, 6 Mbps) • 802.11n draft 2.0, 20MHz (130, 117, 104, 78, 58.5, 52, 39, 26, 19.5, 6.5 Mbps) • 802.11n draft 2.0, 40MHz (270, 243, 216, 162, 135, 121.5, 108, 81, 54, 40, 27, 13.5 Mbps)



Feature	Description
Number of Channels	802.11b/g/n draft 2.0, 20MHz: -USA, Canada and Taiwan: CH 1 ~ 11 (11channels) -Most European Countries: CH 1 ~ 13 (13channels) -France: CH 1 ~ 7 (7channels) 802.11n draft 2.0, 40MHz: -USA, Canada and Taiwan: CH 3 ~ 9 (7channels) -Most European Countries: CH 1 ~ 13 (13channels) -France: CH 3 ~ 5 (3channels) 802.11a/n draft 2.0, 20MHz: -USA, Canada and Taiwan: CH 36,40,44,48 (4channels) -Most European Countries: CH 36,40,44,48 (4channels) -France: CH 36,40,44,48 (4channels) 802.11a/n draft 2.0, 40MHz: -USA, Canada and Taiwan: CH 38,42,46 (3channels) -Most European Countries: CH 38,42,46 (3channels) -France: CH 38,42,46 (3channels)
Output Power	FCC: 802.11b: 17-20 dBm, 802.11g: 15-18 dBm, 802.11n: 10-16 dBm 802.11a: 17-18 dBm, 802.11an: 12-17 dBm. CE: 802.11b: 15-19 dBm, 802.11g: 13-20 dBm, 802.11n: 14-19 dBm 802.11a: 12-24 dBm, 802.11an: 10-20 dBm.
Antenna Type and Gain	Right Antenna : Printed antenna, 4.2 dBi (2.4GHz Band) 7.7 dBi (5GHz Band) Left Antenna: Printed antenna, 3.9 dBi (2.4GHz Band) 6.7 dBi (5GHz Band)

2.2. Carrier Frequency of Channels

802.11a, 802.11Draft n, 20MHz (5150 ~ 5250MHz)

Channel	Frequency(MHz)	Channel	Frequency(MHz)
36	5180	48	5240
40	5200	---	---
44	5220	---	---

802.11Draft n, 40MHz (5150 ~ 5250MHz)

Channel	Frequency(MHz)	Channel	Frequency(MHz)
38	5190	46	5230
42	5210	---	---



2.3. Test Mode and Test Software

- a. During testing, the interface cables and equipment positions were varied according to ANSI C63.4.
- b. The complete test system included remote workstation, PC, Monitor, Keyboard, Mouse, Modem, Printer, Flash memory and EUT for RF test. The remote workstation means Notebook.
- c. An executive program, "Hyper terminal" under WIN XP, which transmits and receives data to the remote workstation through LAN (100M) and Wireless (13.5M).
- d. The following test mode and test software was performed for conduction and radiation test:
 - 802.11a/an, HT20: CH 36: 5180MHz, CH 44: 5220MHz, CH 48: 5240MHz
 - 802.11an, HT40: CH 38: 5190MHz, CH 46: 5230MHz

2.4. Description of Test System

Device	Manufacturer	Model No.	Description
PC	IBM	IGV	Power Cable, Unshielding 1.8 m
Monitor	SlimAGE	510A	Power Cable, Adapter Unshielding 1.8 m Data Cable, VGA Shielding 1.35 m
Monitor	BENQ	Q24W5	Power Cable, Adapter Unshielding 1.8 m Data Cable, VGA Shielding 1.35 m
Keyboard	IBM	KB-0225	Data Cable, PS2 Shielding 1.85 m
Mouse	IBM	MO28VO	Data Cable, USB Shielding 1.85 m
Modem	ACEXX	DM-1414	Power Cable, Adapter Unshielding 1.8 m Data Cable, RS232 Shielding 1.35 m
Printer	HP	Desk Jet 400	Power Cable, Adapter Unshielding 1.8 m Data Cable, Print Shielding 1.6 m
Flash memory * 2	Transcend	JF-512M	N/A
Notebook (Remote Workstation)	TOSHIBA	PSA50T-05M00C	Power Cable, Adapter Unshielding 1.8 m

Use Cable:

Cable	Quantity	Description
RJ45	1	Unshielding, 5.0m
YPbPr	1	Unshielding, 1.5m
AV	1	Unshielding, 1.5m
S-Video	1	Unshielding, 1.5m

Cable	Quantity	Description
HDMI	1	Shielding, 1.5m
S/PDIF	1	Unshielding, 0.5m
Fiber	1	Unshielding, 0.5m
USB	1	Shielding, 1.5m



2.5. Connection Diagram of Test System

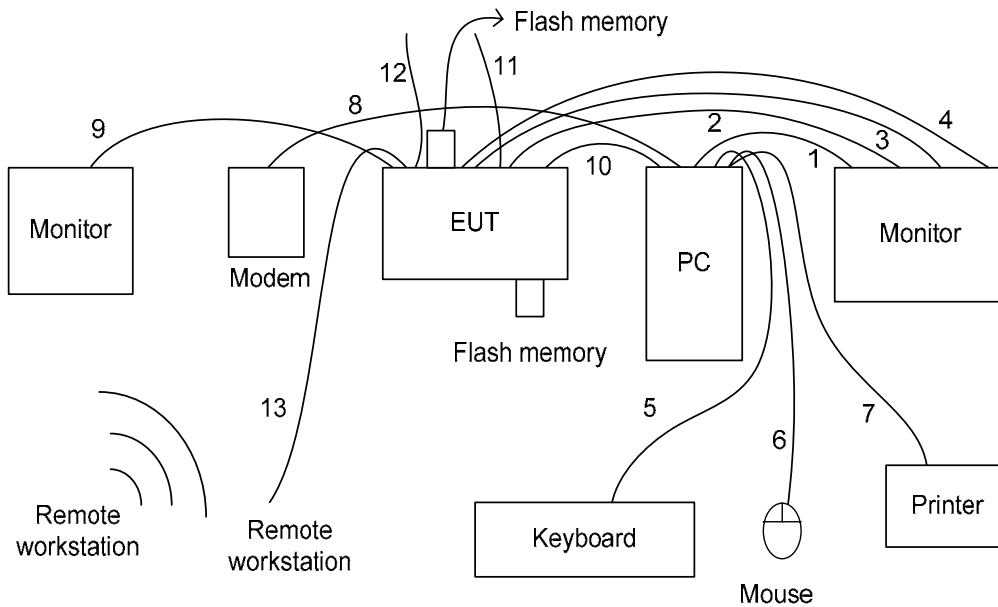

1. The VGA cable is connected from PC to the Monitor.
2. The HDMI cable is connected from EUT to the Monitor.
3. The S-Video cable is connected from EUT to the Monitor.
4. The YPbPr cable is connected from EUT to the Monitor.
5. The PS2 cable is connected from PC to the Keyboard.
6. The USB cable is connected from PC to the Mouse.
7. The Print cable is connected from PC to the Printer.
8. The RS232 cable is connected from PC to the Modem.
9. The AV cable is connected from EUT to the Monitor.
10. The USB cable is connected from PC to the EUT.
11. The S/PDIF cable is floating.
12. The Fiber cable is floating.
13. The RJ45 cable is connected from EUT to the Remote workstation.



2.6. General Information of Test

Test Site:	CerpPASS Technology Corporation 4F-2, No. 28, Lane 78, Xing-Ai Rd. Nei-hu, Taipei City 114 Taiwan R.O.C.
FCC Registration Number :	632249
IC Registration Number :	4934B-1
VCCI Registration Number :	T-338 for Telecommunication Test C-2188 for Conducted emission test R-1902 for Radiated emission test
Test Voltage:	AC 120V/ 60Hz
Test in Compliance with:	ANSI C63.4-2003 FCC Part 15 Subpart E
Frequency Range Investigated:	AC Power Conducted Emission : from 150kHz to 30 MHz Radiated and conducted Emission: from 30 MHz to 40 GHz
Test Distance:	The test distance of radiated emission from antenna to EUT is 3 M.



3. Antenna Requirements

3.1. Standard Applicable

For intentional device, according to FCC 47 CFR Section 15.203, an intentional radiator shall be designed to ensure that no antenna other than that furnished by the responsible party shall be used with the device.

And according to FCC 47 CFR Section 15.407 (a), if transmitting antennas of directional gain greater than 6dBi are used, the power shall be reduced by the amount in dB that the directional gain of the antenna exceeds 6dBi.

3.2. Antenna Construction and Directional Gain

Right Antenna (R): Printed antenna, 7.7 dBi (5GHz Band)

Left Antenna (L): Printed antenna, 6.7 dBi (5GHz Band)

Note:

1. For the band 5.15-5.25 GHz, the maximum conducted output power over the frequency band of operation shall not exceed the lesser of 50 mW or $4 \text{ dBm} + 10\log B$, where B is the 26-dB emission bandwidth in MHz. In addition, the peak power spectral density shall not exceed 4 dBm in any 1-MHz band. If transmitting antennas of directional gain greater than 6 dBi are used, both the maximum conducted output power and the peak power spectral density shall be reduced by the amount in dB that the directional gain of the antenna exceeds 6 dBi.
2. For the band 5.725-5.825 GHz, the maximum conducted output power over the frequency band of operation shall not exceed the lesser of 1 W or $17 \text{ dBm} + 10\log B$, where B is the 26-dB emission bandwidth in MHz. In addition, the peak power spectral density shall not exceed 17 dBm in any 1-MHz band.
If transmitting antennas of directional gain greater than 6 dBi are used, both the maximum conducted output power and the peak power spectral density shall be reduced by the amount in dB that the directional gain of the antenna exceeds 6 dBi.
However, fixed point-to-point U-NII devices operating in this band may employ transmitting antennas with directional gain up to 23 dBi without any corresponding reduction in the transmitter peak output power or peak power spectral density.
For fixed, point-to-point U-NII transmitters that employ a directional antenna gain greater than 23 dBi, a 1 dB reduction in peak transmitter power and peak power spectral density for each 1 dB of antenna gain in excess of 23 dBi would be required.
Fixed, point-to-point operations exclude the use of point-to-multipoint systems, omnidirectional applications, and multiple collocated transmitters transmitting the same information. The operator of the U-NII device, or if the equipment is professionally installed, the installer, is responsible for ensuring that systems employing high gain directional antennas are used exclusively for fixed, point-to-point operations.



4. Test of Conducted Emission

Conducted Emissions were measured from 150 kHz to 30 MHz with a bandwidth of 9 KHz on the 120 VAC power and return leads of the EUT according to the methods defined in ANSI C63.4-2003 Section 3.1. The EUT was placed on a nonmetallic stand in a shielded room 0.8 meters above the ground plane as shown in section 1.3.1. The interface cables and equipment positioning were varied within limits of reasonable applications to determine the position produced maximum conducted emissions.

4.1. Test Procedures

- a. The EUT was placed 0.4 meter from the conducting wall of the shielding room was kept at least 80 centimeters from any other grounded conducting surface.
- b. Connect EUT to the power mains through a line impedance stabilization network (LISN).
- c. All the support units are connecting to the other LISN.
- d. The LISN provides 50 ohm coupling impedance for the measuring instrument.
- e. The FCC states that a 50 ohm, 50 micro-Henry LISN should be used.
- f. Both sides of AC line were checked for maximum conducted interference.
- g. The frequency range from 150 kHz to 30 MHz was searched.
- h. Set the test-receiver system to Peak Detect Function and Specified Bandwidth with Maximum Hold Mode.



4.2. Typical Test Setup Layout of Conducted Emission

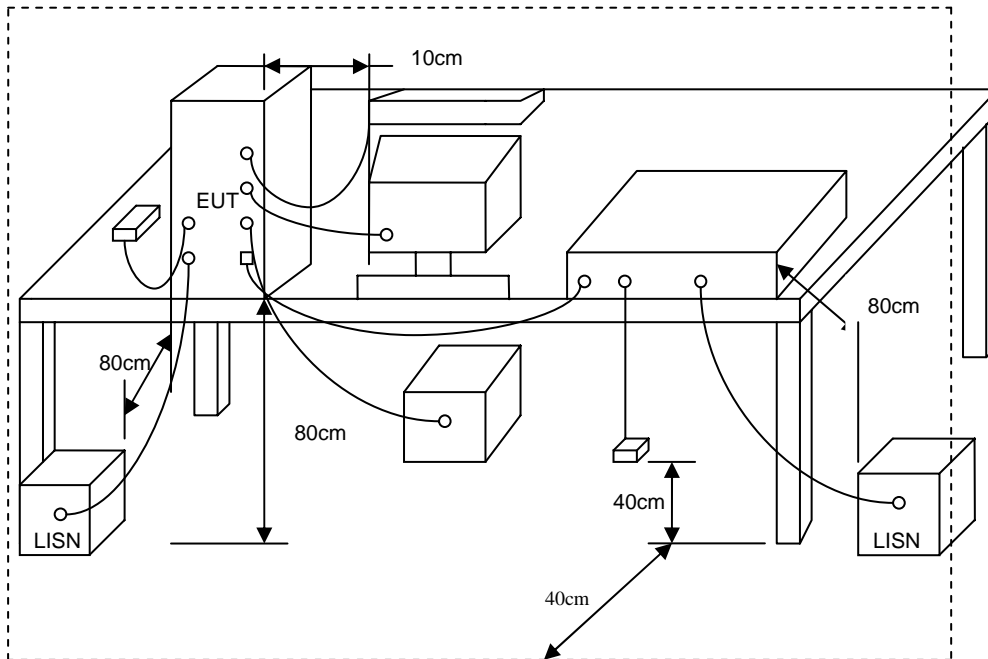

4.3. Conducted Emission Requirement

Conducted Emissions were measured from 150 kHz to 30 MHz with a bandwidth of 9 KHz on the 120 VAC power and return leads of the EUT according to the methods defined in ANSI C63.4-2003 Section 3.1. The EUT was placed on a nonmetallic stand in a shielded room 0.8 meters above the ground plane as shown in section 2.2. The interface cables and equipment positioning were varied within limits of reasonable applications to determine the position produced maximum conducted emissions.

Frequency (MHz)	Quasi Peak (dB μ V)	Average (dB μ V)
0.15 – 0.5	66-56*	56-46*
0.5 – 5.0	56	46
5.0 – 30.0	60	50

*Decreases with the logarithm of the frequency.

4.4. Measurement Equipment

Instrument/Ancillary	Model No.	Manufacturer	Serial No.	Calibration Date	Valid Date.
EMI Receiver	SCHAFFNER	SCR-3501	437	2007/11/26	2008/11/25
LISN	NNB-2/16Z	MESS TEC	02/10191	2008/06/03	2009/06/02
LISN	NNB-2/16Z	ROLF HEINE	03/10058	2008/04/19	2009/04/18



4.5. Test Result and Data

Power	: AC 120V	Pol/Phase	: LINE
Test Mode 1	: 802.11a, CH36	Temperature	: 24 °C
Memo	:	Humidity	: 55 %

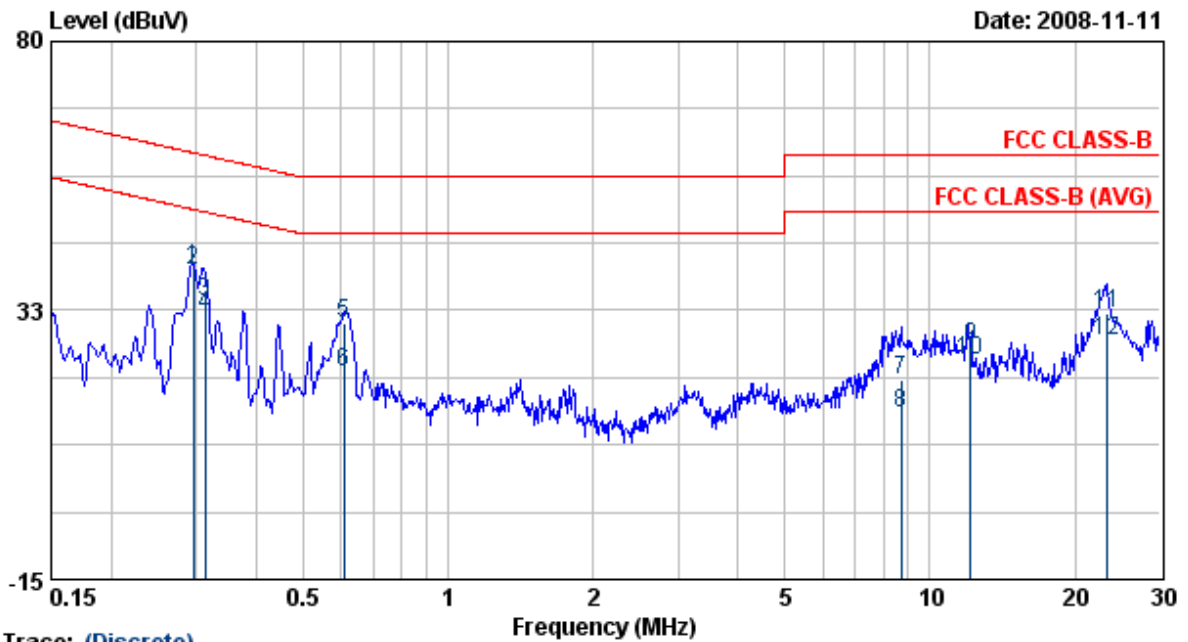

Trace: (Discrete)

Item	Freq	Read Value	Factor	Result	Limit	Margin	Remark
	MHz	dBuV	dB	dBuV	dBuV	dBuV	
1	0.30	39.87	0.12	39.99	60.34	-20.35	QP
2	0.30	39.48	0.12	39.60	50.34	-10.74	AVERAGE
3	0.31	33.90	0.12	34.02	59.88	-25.86	QP
4	0.31	31.53	0.12	31.65	49.88	-18.23	AVERAGE
5	0.61	30.11	0.14	30.25	56.00	-25.75	QP
6	0.61	21.60	0.14	21.74	46.00	-24.26	AVERAGE
7	8.73	19.90	0.35	20.26	60.00	-39.74	QP
8	8.73	14.05	0.35	14.41	50.00	-35.59	AVERAGE
9	12.13	25.66	0.40	26.06	60.00	-33.94	QP
10	12.13	23.18	0.40	23.58	50.00	-26.42	AVERAGE
11	23.29	31.49	0.43	31.92	60.00	-28.08	QP
12	23.29	26.61	0.43	27.05	50.00	-22.95	AVERAGE

- Remarks:
- Level = Read Level + Factor
 - Factor = LISN(ISN) Factor + Cable Loss
 - According to technical experiences, all spurious emission of 802.11a mode at channel 36,44,48 are almost the same below 1GHz, so that the channel 36 was chosen as representative in final test.
 - The data is worse case.



Power	: AC 120V	Pol/Phase	: NEUTRAL
Test Mode 1	: 802.11a, CH36	Temperature	: 24 °C
Memo	:	Humidity	: 55 %

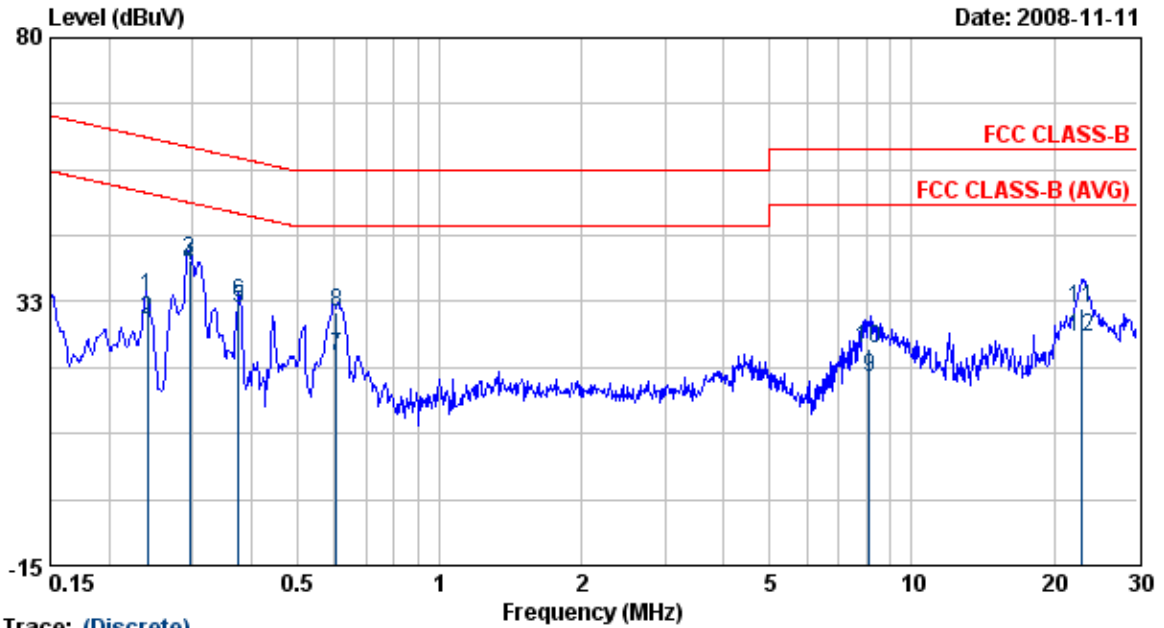

Trace: (Discrete)

Item	Freq	Read Value	Factor	Result	Limit	Margin	Remark
	MHz	dBuV	dB	dBuV	dBuV	dBuV	
1	0.24	33.31	0.14	33.45	62.04	-28.60	QP
2	0.24	29.21	0.14	29.35	52.04	-22.69	AVERAGE
3	0.30	39.63	0.14	39.77	60.37	-20.60	QP
4	0.30	38.81	0.14	38.95	50.37	-11.42	AVERAGE
5	0.38	31.20	0.15	31.35	48.36	-17.01	AVERAGE
6	0.38	32.31	0.15	32.46	58.36	-25.90	QP
7	0.60	22.34	0.16	22.50	46.00	-23.50	AVERAGE
8	0.60	30.59	0.16	30.75	56.00	-25.25	QP
9	8.11	18.49	0.38	18.87	50.00	-31.13	AVERAGE
10	8.11	23.51	0.38	23.89	60.00	-36.11	QP
11	22.84	30.61	0.60	31.21	60.00	-28.79	QP
12	22.84	25.39	0.60	25.98	50.00	-24.02	AVERAGE

- Remarks:
1. Level = Read Level + Factor
 2. Factor = LISN(ISN) Factor + Cable Loss
 3. According to technical experiences, all spurious emission of 802.11a mode at channel 36,44,48 are almost the same below 1GHz, so that the channel 36 was chosen as representative in final test.
 4. The data is worse case.



Power	: AC 120V	Pol/Phase	: LINE
Test Mode 2	: 802.11an HT20, CH36	Temperature	: 24 °C
Memo	:	Humidity	: 55 %

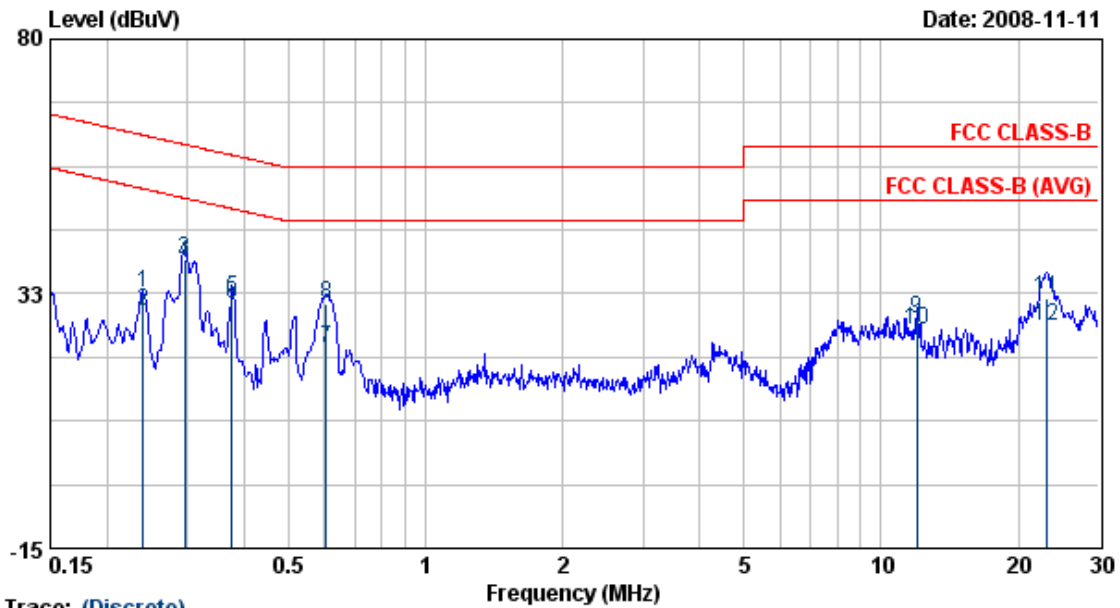

Trace: (Discrete)

Item	Freq	Read Value	Factor	Result	Limit	Margin	Remark
	MHz	dBuV	dB	dBuV	dBuV	dBuV	
1	0.24	32.52	0.12	32.63	62.08	-29.45	QP
2	0.24	28.94	0.12	29.05	52.08	-23.03	AVERAGE
3	0.30	38.79	0.12	38.91	60.36	-21.45	QP
4	0.30	37.99	0.12	38.11	50.36	-12.25	AVERAGE
5	0.38	31.68	0.12	31.80	58.37	-26.57	QP
6	0.38	30.48	0.12	30.60	48.37	-17.77	AVERAGE
7	0.60	22.34	0.14	22.48	46.00	-23.52	AVERAGE
8	0.60	30.47	0.14	30.61	56.00	-25.39	QP
9	12.00	27.59	0.40	27.99	60.00	-32.01	QP
10	12.00	25.51	0.40	25.91	50.00	-24.09	AVERAGE
11	23.03	31.19	0.43	31.63	60.00	-28.37	QP
12	23.03	26.08	0.43	26.51	50.00	-23.49	AVERAGE

- Remarks:
1. Level = Read Level + Factor
 2. Factor = LISN(ISN) Factor + Cable Loss
 3. According to technical experiences, all spurious emission of 802.11an HT20 mode at channel 36,44,48 are almost the same below 1GHz, so that the channel 36 was chosen as representative in final test.
 4. The data is worse case.



Power	: AC 120V	Pol/Phase	: NEUTRAL
Test Mode 2	: 802.11an HT20, CH36	Temperature	: 24 °C
Memo	:	Humidity	: 55 %

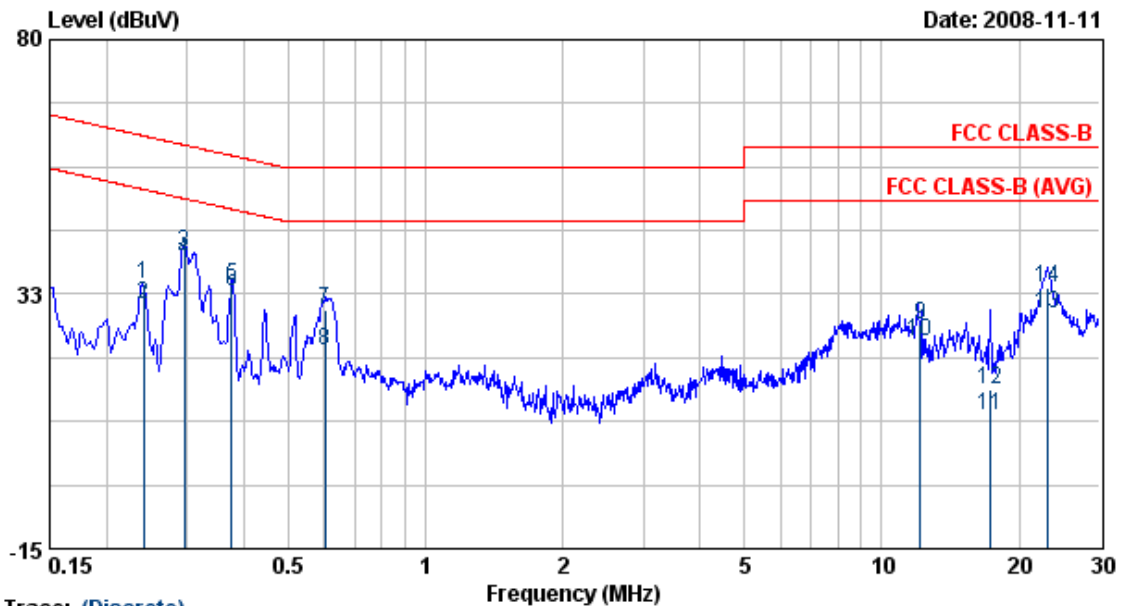

Trace: (Discrete)

Item	Freq	Read Value	Factor	Result	Limit	Margin	Remark
	MHz	dBuV	dB	dBuV	dBuV	dBuV	
1	0.24	34.15	0.14	34.29	62.07	-27.78	QP
2	0.24	30.29	0.14	30.43	52.07	-21.64	AVERAGE
3	0.30	39.96	0.14	40.11	60.37	-20.26	QP
4	0.30	38.82	0.14	38.96	50.37	-11.41	AVERAGE
5	0.38	33.86	0.15	34.01	58.36	-24.35	QP
6	0.38	32.87	0.15	33.02	48.36	-15.34	AVERAGE
7	0.60	29.54	0.16	29.70	56.00	-26.30	QP
8	0.60	21.63	0.16	21.79	46.00	-24.21	AVERAGE
9	12.13	26.29	0.43	26.72	60.00	-33.28	QP
10	12.13	23.41	0.43	23.83	50.00	-26.17	AVERAGE
11	17.26	9.19	0.53	9.71	50.00	-40.29	AVERAGE
12	17.26	14.29	0.53	14.82	60.00	-45.18	QP
13	23.11	28.26	0.60	28.86	50.00	-21.14	AVERAGE
14	23.11	32.98	0.60	33.58	60.00	-26.42	QP

- Remarks:
- Level = Read Level + Factor
 - Factor = LISN(ISN) Factor + Cable Loss
 - According to technical experiences, all spurious emission of 802.11an HT20 mode at channel 36,44,48 are almost the same below 1GHz, so that the channel 36 was chosen as representative in final test.
 - The data is worse case.



Power	: AC 120V	Pol/Phase	: LINE
Test Mode 3	: 802.11an HT40, CH38	Temperature	: 24 °C
Memo	:	Humidity	: 55 %

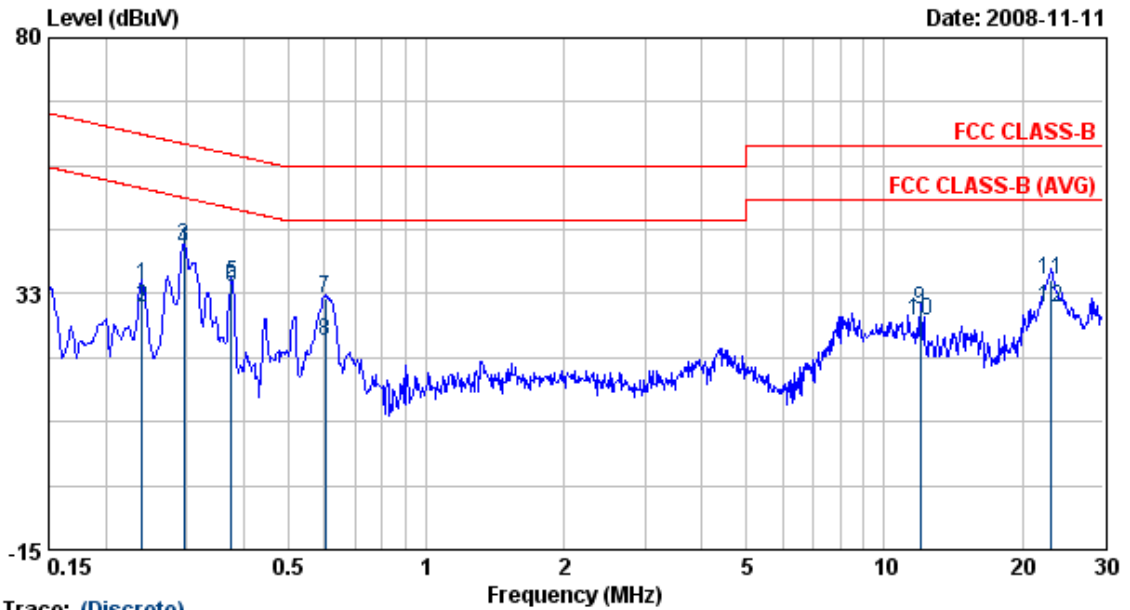

Trace: (Discrete)

Item	Freq	Read Value	Factor	Result	Limit	Margin	Remark
	MHz	dBuV	dB	dBuV	dBuV	dBuV	
1	0.24	33.97	0.12	34.09	62.08	-28.00	QP
2	0.24	29.72	0.12	29.84	52.08	-22.25	Average
3	0.30	41.24	0.12	41.36	60.37	-19.01	QP
4	0.30	40.38	0.12	40.50	50.37	-9.87	Average
5	0.38	34.36	0.12	34.48	58.39	-23.90	QP
6	0.38	33.53	0.12	33.65	48.39	-14.74	Average
7	0.60	31.34	0.14	31.48	56.00	-24.52	QP
8	0.60	23.38	0.14	23.52	46.00	-22.48	Average
9	12.00	29.28	0.40	29.68	60.00	-30.32	QP
10	12.00	27.10	0.40	27.50	50.00	-22.50	Average
11	23.14	34.73	0.43	35.16	60.00	-24.84	QP
12	23.14	29.31	0.43	29.74	50.00	-20.26	Average

- Remarks:
- Level = Read Level + Factor
 - Factor = LISN(ISN) Factor + Cable Loss
 - According to technical experiences, all spurious emission of 802.11an HT40 mode at channel 38, 42, 46 are almost the same below 1GHz, so that the channel 38 was chosen as representative in final test.
 - The data is worse case.



Power	: AC 120V	Pol/Phase	: NEUTRAL
Test Mode 3	: 802.11an HT40, CH38	Temperature	: 24 °C
Memo	:	Humidity	: 55 %

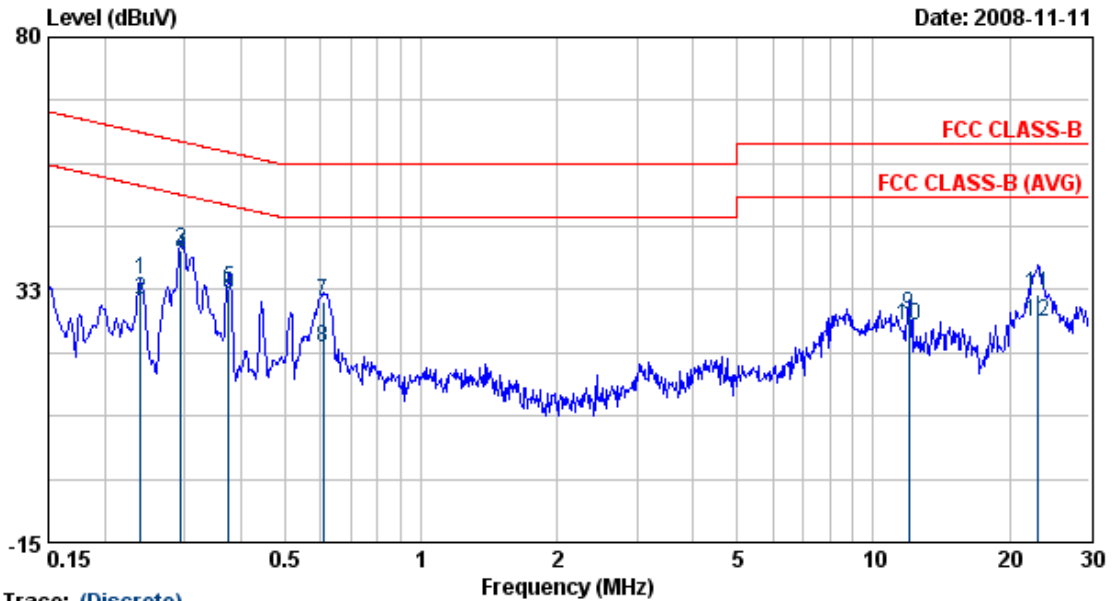

Trace: (Discrete)

Item	Freq	Read Value	Factor	Result	Limit	Margin	Remark
	MHz	dBuV	dB	dBuV	dBuV	dBuV	
1	0.24	34.22	0.14	34.36	62.09	-27.73	QP
2	0.24	30.52	0.14	30.66	52.09	-21.43	AVERAGE
3	0.30	39.84	0.14	39.98	60.38	-20.40	QP
4	0.30	38.79	0.14	38.93	50.38	-11.44	AVERAGE
5	0.38	32.53	0.15	32.67	58.39	-25.71	QP
6	0.38	31.51	0.15	31.66	48.39	-16.73	AVERAGE
7	0.61	30.20	0.16	30.36	56.00	-25.64	QP
8	0.61	21.62	0.16	21.78	46.00	-24.22	AVERAGE
9	12.00	27.58	0.43	28.01	60.00	-31.99	QP
10	12.00	25.43	0.43	25.86	50.00	-24.14	AVERAGE
11	23.14	31.03	0.60	31.62	60.00	-28.38	QP
12	23.14	25.80	0.60	26.39	50.00	-23.61	AVERAGE

- Remarks:
1. Level = Read Level + Factor
 2. Factor = LISN(ISN) Factor + Cable Loss
 3. According to technical experiences, all spurious emission of 802.11an HT40 mode at channel 38,42,46 are almost the same below 1GHz, so that the channel 38 was chosen as representative in final test.
 4. The data is worse case.

Test engineer: Ben



5. Test of Radiated Emission

Radiated emissions from 30 MHz to 40 GHz were measured according to the methods defines in ANSI C63.4-2003. The EUT was placed, 0.8 meter above the ground plane, as shown in section 1.4.2. The interface cables and equipment positions were varied within limits of reasonable applications to determine the positions producing maximum radiated emissions

5.1. Test Procedures

- a. The EUT was placed on a rotatable table top 0.8 meter above ground.
- b. The EUT was set 3 meters from the interference receiving antenna which was mounted on the top of a variable height antenna tower.
- c. The table was rotated 360 degrees to determine the position of the highest radiation.
- d. The antenna is a broadband antenna and its height is varied between one meter and four meters above ground to find the maximum value of the field strength both horizontal polarization and vertical polarization of the antenna are set to make the measurement.
- e. For each suspected emission the EUT was arranged to its worst case and then tune the antenna tower (from 1 M to 4 M) and turn table (from 0 degree to 360 degrees) to find the maximum reading.
- f. Set the test-receiver system to Peak or CISPR quasi-peak Detect Function and specified bandwidth with Maximum Hold Mode.
- g. If the emission level of the EUT in peak mode was 3 dB lower than the limit specified, then testing will be stopped and peak values of EUT will be reported, otherwise, the emissions which do not have 3 dB margin will be repeated one by one using the quasi-peak method and reported.
- h. For testing above 1GHz, the emission level of the EUT in peak mode was 20dB lower than average limit (that means the emission level in peak mode also complies with the limit in average mode), then testing will be stopped and peak values of EUT will be reported, otherwise, the emissions will be measured in average mode again and reported.
- i. "Cone of radiation" has been considered to be 3dB beamwidth of the measurement antenna.



5.2. Typical Test Setup Layout of Radiated Emission

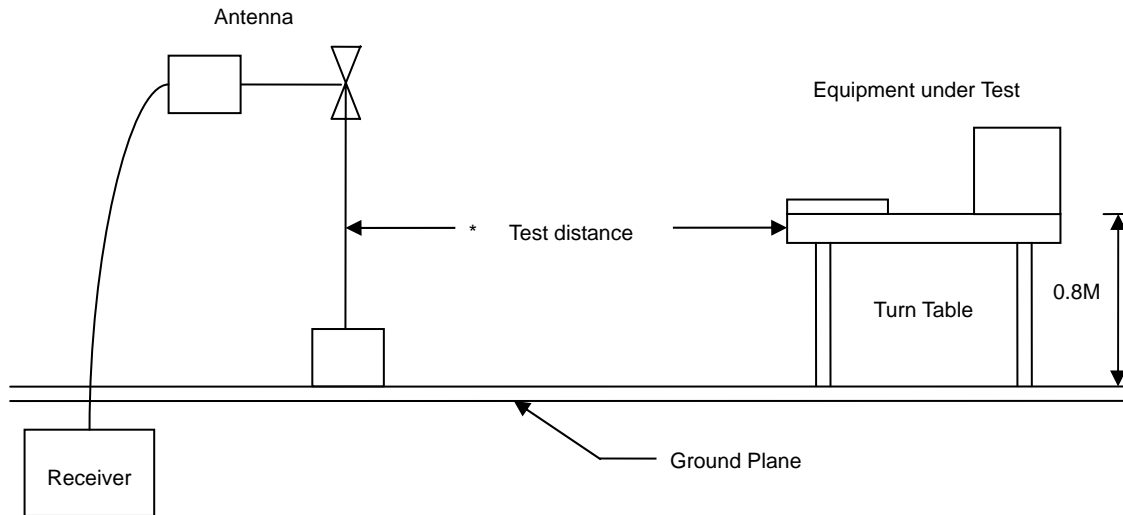

5.3. Measurement Equipment

Instrument/Ancillary	Model No.	Manufacturer	Serial No.	Calibration Date	Valid Date
Bilog Antenna	CBL6112B	Schaffner	2840	2008/05/15	2009/05/14
Signal Generator	8648B	HP	3629U00612	2008/10/08	2009/10/07
Amplifier	8447D	Agilent	2944A10593	2008/05/26	2009/05/25
EMI Receiver	SCR-3501	SCHAFFNER	437	2007/11/26	2008/11/25
Spectrum	FSP40	R&S	100047	2008/02/22	2009/02/21
Horn Antenna	3115	EMCO	31589	2008/04/01	2009/03/30
Amplifier	8449B	Agilent	3008A01954	2008/01/24	2009/01/23



5.4. Test Result of Radiated Emission

Power	: AC 120V	Pol/Phase	: VERTICAL
Test Mode 1	: 802.11a, CH36	Temperature	: 22 °C
Memo	:	Humidity	: 70 %

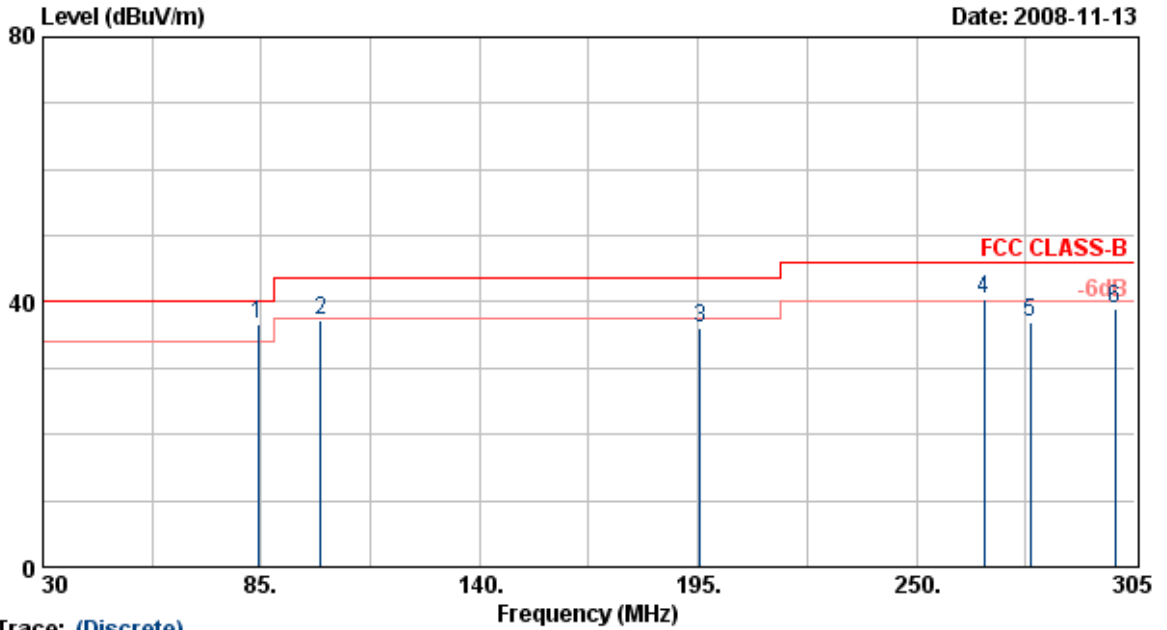

Trace: (Discrete)

Item	Freq	Read Value	Factor	Result	Limit	Margin	Remark	Ant Pos	Tab Pos
	MHz	dBuV/m	dB	dBuV/m	dBuV/m	dB		cm	Deg
1	84.18	53.64	-16.94	36.71	40.00	-3.29	QP	100	154
2	99.85	51.53	-14.37	37.16	43.50	-6.34	Peak	100	88
3	195.55	47.20	-11.12	36.09	43.50	-7.41	Peak	100	62
4	267.05	48.84	-8.47	40.38	46.00	-5.62	QP	100	102
5	278.60	44.11	-7.10	37.01	46.00	-8.99	Peak	100	122
6	300.05	48.44	-9.49	38.95	46.00	-7.05	Peak	100	88

Notes:

1. Result = Read Value + Factor
2. Factor = Antenna Factor + Cable Loss - Amplifier
3. The resolution bandwidth of test receiver/spectrum analyzer is 120KHz and video bandwidth is 300kHz for Peak detection and Quasi-peak detection at frequency below 1GHz.
4. According to technical experiences, all spurious emission of 802.11a mode at channel 36,44,48 are almost the same below 1GHz, so that the channel 36 was chosen as representative in final test.
5. The data is worse case.



Power	: AC 120V	Pol/Phase	: VERTICAL
Test Mode 1	: 802.11a, CH36	Temperature	: 22 °C
Memo	:	Humidity	: 70 %

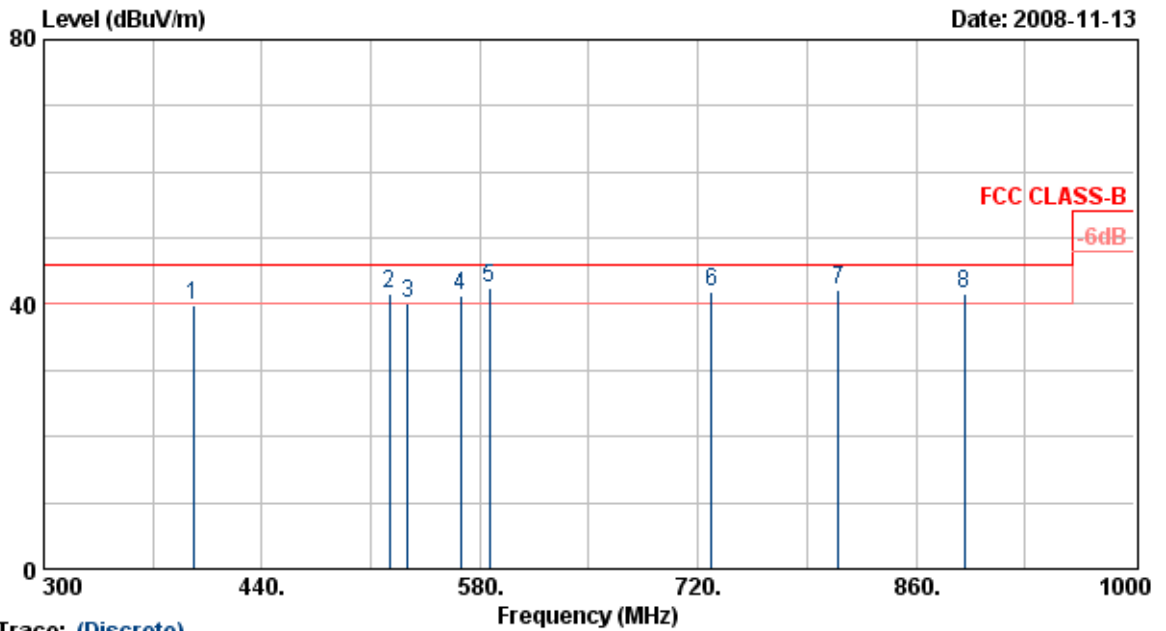

Trace: (Discrete)

Item	Freq	Read Value	Factor	Result	Limit	Margin	Remark	Ant Pos	Tab Pos
	MHz	dBuV/m	dB	dBuV/m	dBuV/m	dB		cm	Deg
1	395.90	47.14	-7.20	39.94	46.00	-6.06	Peak	100	92
2	521.90	45.69	-4.18	41.51	46.00	-4.49	QP	100	80
3	533.80	43.99	-3.83	40.16	46.00	-5.84	QP	100	105
4	567.40	39.97	1.35	41.32	46.00	-4.68	QP	100	147
5	586.30	42.96	-0.36	42.60	46.00	-3.40	QP	100	82
6	728.40	39.10	2.80	41.90	46.00	-4.10	QP	100	103
7	810.30	44.69	-2.62	42.07	46.00	-3.93	QP	100	105
8	890.80	39.82	1.72	41.54	46.00	-4.46	QP	100	99

Notes:

1. Result = Read Value + Factor
2. Factor = Antenna Factor + Cable Loss - Amplifier
3. The resolution bandwidth of test receiver/spectrum analyzer is 120KHz and video bandwidth is 300kHz for Peak detection and Quasi-peak detection at frequency below 1GHz.
4. According to technical experiences, all spurious emission of 802.11a mode at channel 36,44,48 are almost the same below 1GHz, so that the channel 36 was chosen as representative in final test.
5. The data is worse case.



Power	: AC 120V	Pol/Phase	: HORIZONTAL
Test Mode 1	: 802.11a, CH36	Temperature	: 22 °C
Memo	:	Humidity	: 70 %

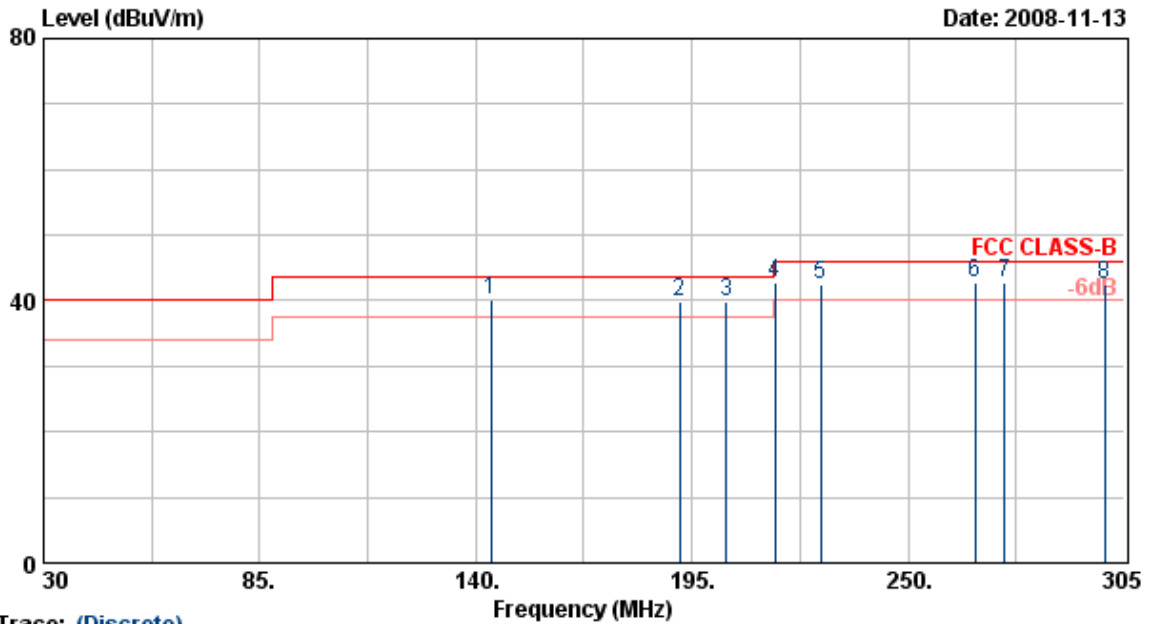

Trace: (Discrete)

Item	Freq	Read Value	Factor	Result	Limit	Margin	Remark	Ant Pos	Tab Pos
	MHz	dBuV/m	dB	dBuV/m	dBuV/m	dB		cm	Deg
1	143.85	57.61	-17.51	40.11	43.50	-3.39	QP	100	102
2	191.98	56.19	-16.47	39.72	43.50	-3.78	QP	100	124
3	203.80	55.70	-15.99	39.71	43.50	-3.79	QP	100	108
4	216.18	61.20	-18.40	42.80	46.00	-3.20	QP	100	85
5	227.73	60.80	-18.26	42.54	46.00	-3.46	QP	100	75
6	267.05	58.21	-15.45	42.76	46.00	-3.24	QP	100	82
7	274.48	57.20	-14.57	42.62	46.00	-3.38	QP	100	122
8	300.05	56.95	-14.49	42.46	46.00	-3.54	QP	100	77

Notes:

1. Result = Read Value + Factor
2. Factor = Antenna Factor + Cable Loss - Amplifier
3. The resolution bandwidth of test receiver/spectrum analyzer is 120KHz and video bandwidth is 300kHz for Peak detection and Quasi-peak detection at frequency below 1GHz.
4. According to technical experiences, all spurious emission of 802.11a mode at channel 36,44,48 are almost the same below 1GHz, so that the channel 36 was chosen as representative in final test.
5. The data is worse case.



Power	: AC 120V	Pol/Phase	: HORIZONTAL
Test Mode 1	: 802.11a, CH36	Temperature	: 22 °C
Memo	:	Humidity	: 70 %

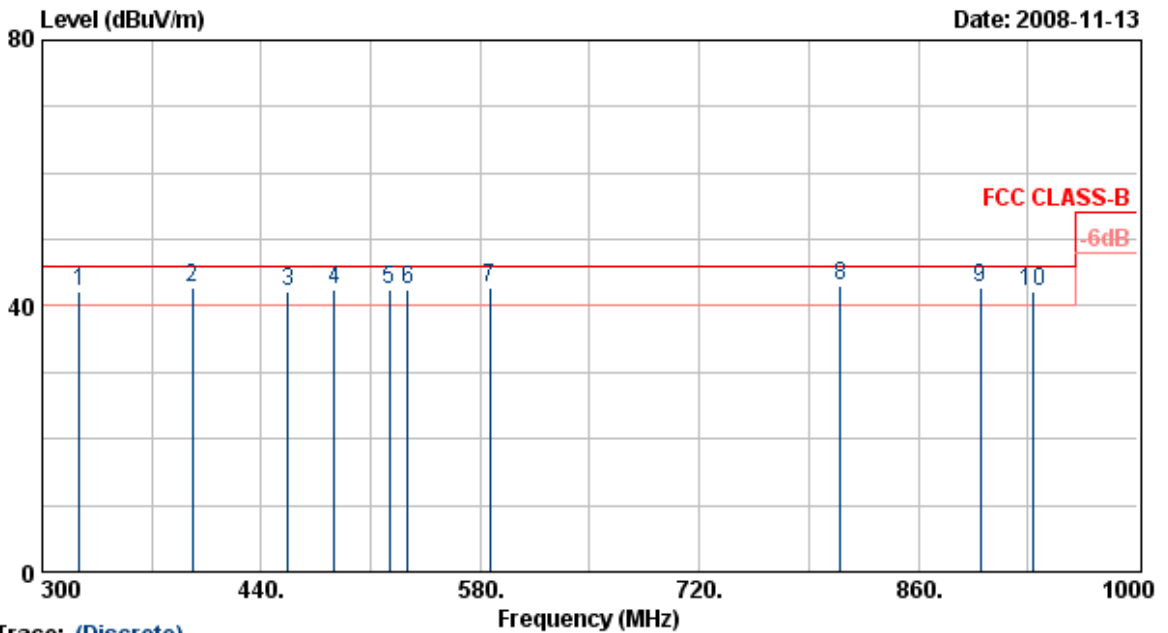

Trace: (Discrete)

Item	Freq	Read Value	Factor	Result	Limit	Margin	Remark	Ant Pos	Tab Pos
	MHz	dBuV/m	dB	dBuV/m	dBuV/m	dB		cm	Deg
1	323.80	54.94	-12.77	42.16	46.00	-3.84	QP	100	95
2	395.90	52.40	-9.52	42.88	46.00	-3.12	QP	100	111
3	456.80	50.96	-8.73	42.23	46.00	-3.77	QP	100	132
4	486.90	48.21	-5.70	42.51	46.00	-3.49	QP	100	145
5	521.90	46.20	-3.85	42.35	46.00	-3.65	QP	100	125
6	533.80	45.32	-2.88	42.44	46.00	-3.56	QP	100	86
7	586.30	45.34	-2.54	42.80	46.00	-3.20	QP	100	63
8	810.30	43.83	-0.87	42.96	46.00	-3.04	QP	100	123
9	899.90	38.80	3.86	42.65	46.00	-3.35	QP	100	99
10	932.80	37.22	5.06	42.27	46.00	-3.73	QP	100	122

Notes:

1. Result = Read Value + Factor
2. Factor = Antenna Factor + Cable Loss - Amplifier
3. The resolution bandwidth of test receiver/spectrum analyzer is 120KHz and video bandwidth is 300kHz for Peak detection and Quasi-peak detection at frequency below 1GHz.
4. According to technical experiences, all spurious emission of 802.11a mode at channel 36,44,48 are almost the same below 1GHz, so that the channel 36 was chosen as representative in final test.
5. The data is worse case.



Power	: AC 120V	Pol/Phase	: VERTICAL
Test Mode 1	: 802.11a, CH36	Temperature	: 22 °C
Memo	:	Humidity	: 70 %

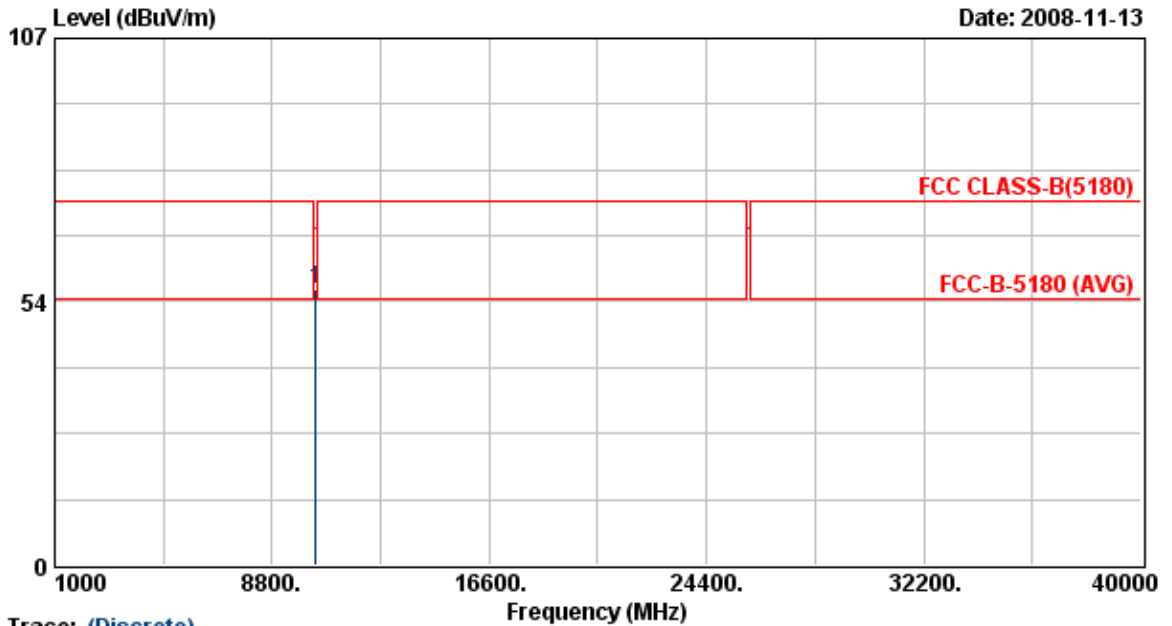

Trace: (Discrete)

Item	Freq	Read Value	Factor	Result	Limit	Margin	Remark	Ant Pos	Tab Pos
	MHz	dBuV/m	dB	dBuV/m	dBuV/m	dB		cm	Deg
1	10360.25	43.45	12.68	56.13	68.30	-12.17	Peak	116	267

Notes:

1. Result = Read Value + Factor
2. Factor = Antenna Factor + Cable Loss - Amplifier
3. The resolution bandwidth of test receiver/spectrum analyzer is 120KHz and video bandwidth is 300kHz for Peak detection and Quasi-peak detection at frequency below 1GHz.
4. The resolution bandwidth of test receiver/spectrum analyzer is 1MHz and video bandwidth is 3MHz for Peak detection at frequency above 1GHz.
5. The resolution bandwidth of test receiver/spectrum analyzer is 1MHz and video bandwidth is 10Hz for Average detection at frequency above 1GHz.
6. The other emissions is too low to be measured.



Power	: AC 120V	Pol/Phase	: HORIZONTAL
Test Mode 1	: 802.11a, CH36	Temperature	: 22 °C
Memo	:	Humidity	: 70 %

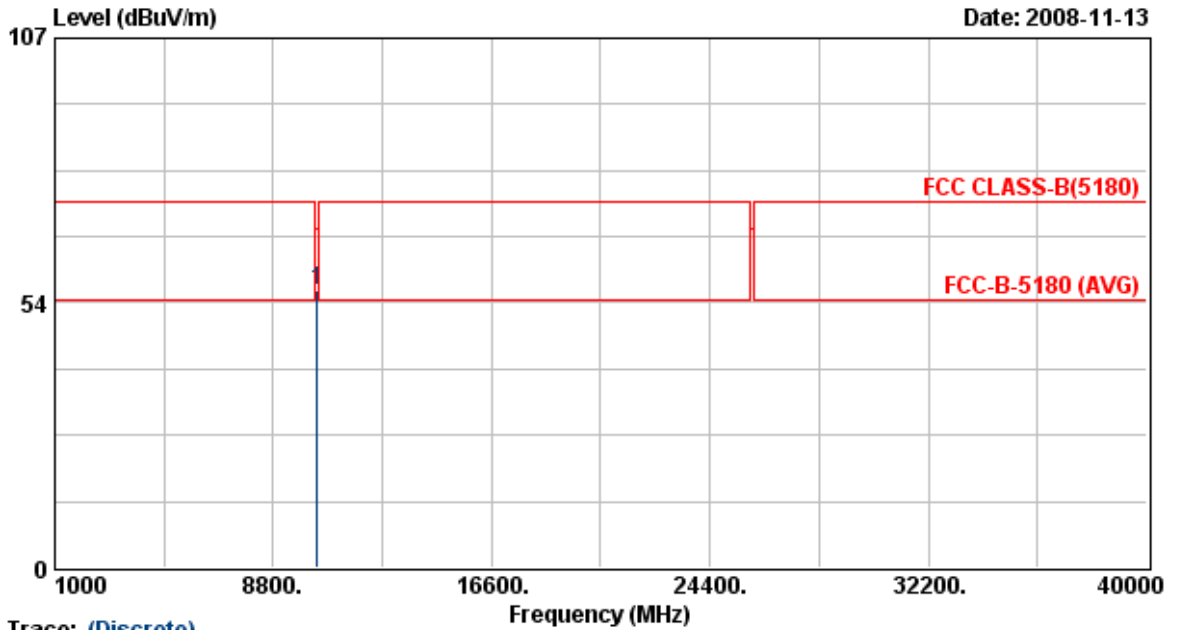

Trace: (Discrete)

Item	Freq	Read Value	Factor	Result	Limit	Margin	Remark	Ant Pos	Tab Pos
	MHz	dBuV/m	dB	dBuV/m	dBuV/m	dB		cm	Deg
1	10360.25	43.53	12.68	56.20	68.30	-12.10	Peak	116	267

Notes:

1. Result = Read Value + Factor
2. Factor = Antenna Factor + Cable Loss - Amplifier
3. The resolution bandwidth of test receiver/spectrum analyzer is 120KHz and video bandwidth is 300kHz for Peak detection and Quasi-peak detection at frequency below 1GHz.
4. The resolution bandwidth of test receiver/spectrum analyzer is 1MHz and video bandwidth is 3MHz for Peak detection at frequency above 1GHz.
5. The resolution bandwidth of test receiver/spectrum analyzer is 1MHz and video bandwidth is 10Hz for Average detection at frequency above 1GHz.
6. The other emissions is too low to be measured.



Power	: AC 120V	Pol/Phase	: VERTICAL
Test Mode 1	: 802.11a, CH44	Temperature	: 22 °C
Memo	:	Humidity	: 70 %

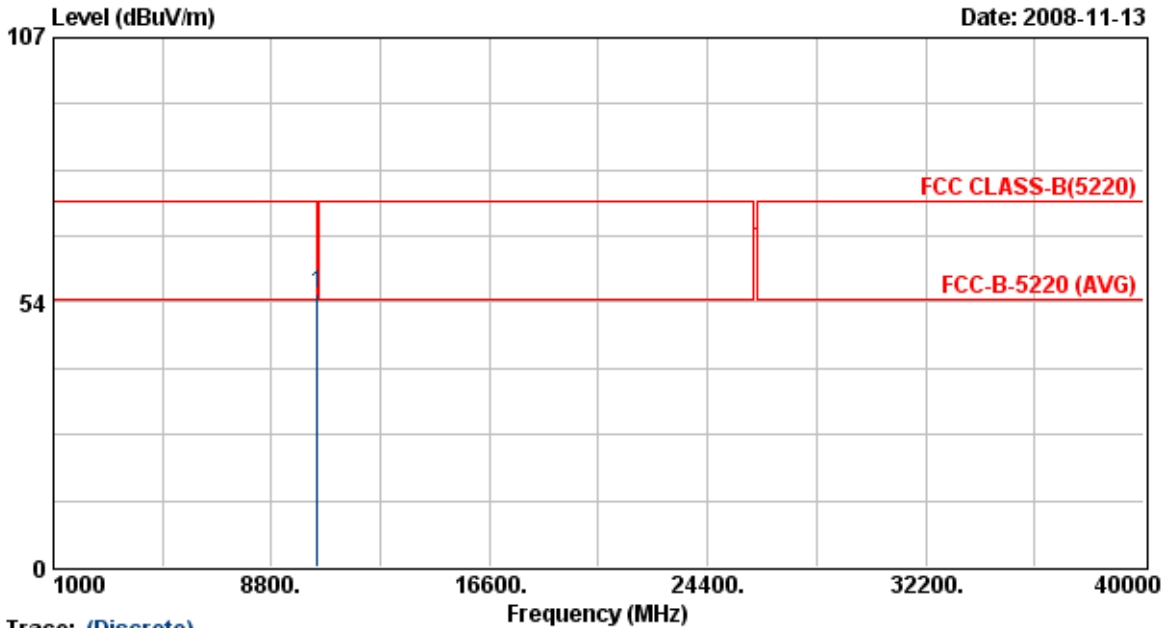

Trace: (Discrete)

Item	Freq	Read Value	Factor	Result	Limit	Margin	Remark	Ant Pos	Tab Pos
	MHz	dBuV/m	dB	dBuV/m	dBuV/m	dB		cm	Deg
1	10439.95	42.34	12.80	55.15	68.30	-13.15	Peak	116	267

Notes:

1. Result = Read Value + Factor
2. Factor = Antenna Factor + Cable Loss - Amplifier
3. The resolution bandwidth of test receiver/spectrum analyzer is 120KHz and video bandwidth is 300kHz for Peak detection and Quasi-peak detection at frequency below 1GHz.
4. The resolution bandwidth of test receiver/spectrum analyzer is 1MHz and video bandwidth is 3MHz for Peak detection at frequency above 1GHz.
5. The resolution bandwidth of test receiver/spectrum analyzer is 1MHz and video bandwidth is 10Hz for Average detection at frequency above 1GHz.
6. The other emissions is too low to be measured.



Power	: AC 120V	Pol/Phase	: HORIZONTAL
Test Mode 1	: 802.11a, CH44	Temperature	: 22 °C
Memo	:	Humidity	: 70 %

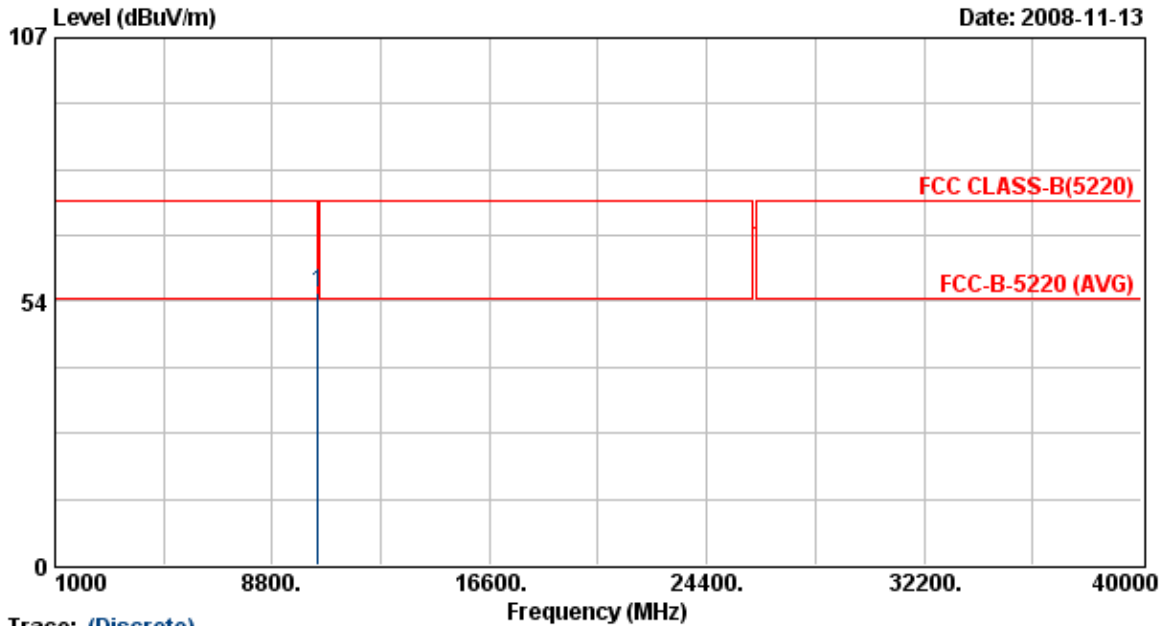

Trace: (Discrete)

Item	Freq	Read Value	Factor	Result	Limit	Margin	Remark	Ant Pos	Tab Pos
	MHz	dBuV/m	dB	dBuV/m	dBuV/m	dB		cm	Deg
1	10439.95	42.32	12.80	55.12	68.30	-13.18	Peak	116	267

Notes:

1. Result = Read Value + Factor
2. Factor = Antenna Factor + Cable Loss - Amplifier
3. The resolution bandwidth of test receiver/spectrum analyzer is 120KHz and video bandwidth is 300kHz for Peak detection and Quasi-peak detection at frequency below 1GHz.
4. The resolution bandwidth of test receiver/spectrum analyzer is 1MHz and video bandwidth is 3MHz for Peak detection at frequency above 1GHz.
5. The resolution bandwidth of test receiver/spectrum analyzer is 1MHz and video bandwidth is 10Hz for Average detection at frequency above 1GHz.
6. The other emissions is too low to be measured.



Power	: AC 120V	Pol/Phase	: VERTICAL
Test Mode 1	: 802.11a, CH48	Temperature	: 22 °C
Memo	:	Humidity	: 70 %

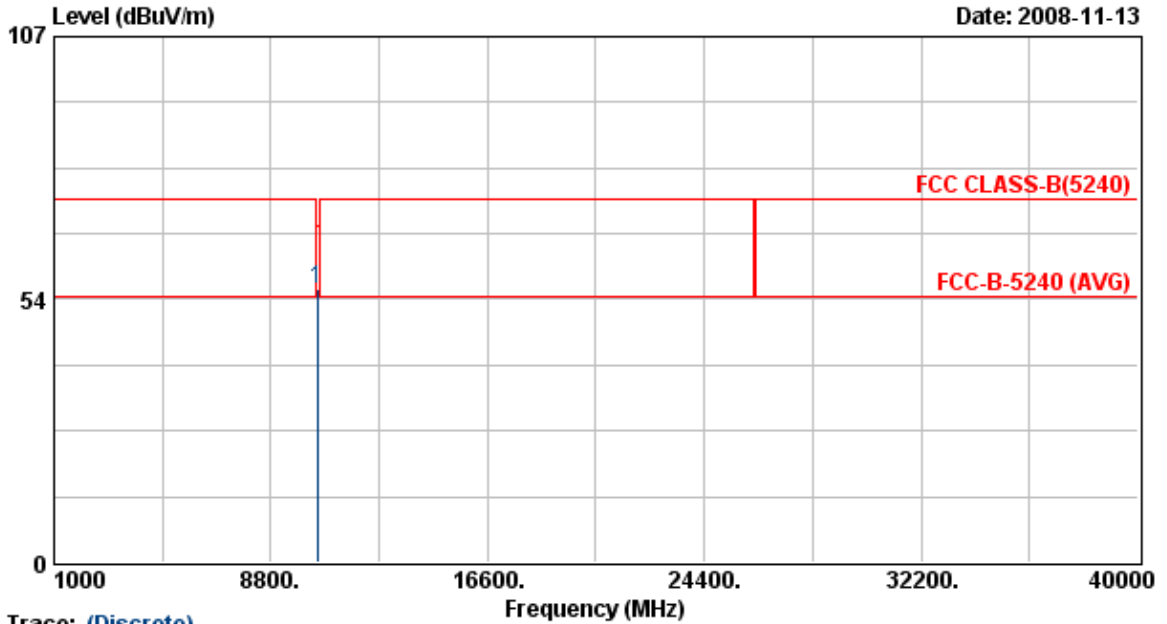

Trace: (Discrete)

Item	Freq	Read Value	Factor	Result	Limit	Margin	Remark	Ant Pos	Tab Pos
	MHz	dBuV/m	dB	dBuV/m	dBuV/m	dB		cm	Deg
1	10479.97	42.90	12.87	55.76	68.30	-12.54	Peak	116	267

Notes:

1. Result = Read Value + Factor
2. Factor = Antenna Factor + Cable Loss - Amplifier
3. The resolution bandwidth of test receiver/spectrum analyzer is 120KHz and video bandwidth is 300kHz for Peak detection and Quasi-peak detection at frequency below 1GHz.
4. The resolution bandwidth of test receiver/spectrum analyzer is 1MHz and video bandwidth is 3MHz for Peak detection at frequency above 1GHz.
5. The resolution bandwidth of test receiver/spectrum analyzer is 1MHz and video bandwidth is 10Hz for Average detection at frequency above 1GHz.
6. The other emissions is too low to be measured.



Power	: AC 120V	Pol/Phase	: HORIZONTAL
Test Mode 1	: 802.11a, CH48	Temperature	: 22 °C
Memo	:	Humidity	: 70 %

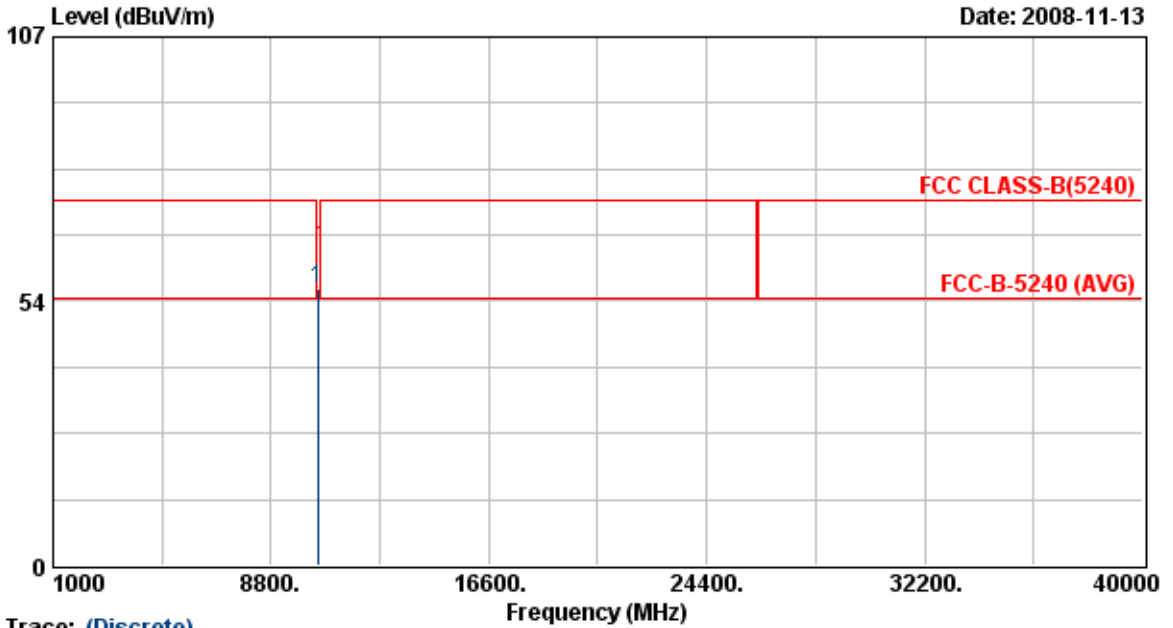

Trace: (Discrete)

Item	Freq	Read Value	Factor	Result	Limit	Margin	Remark	Ant Pos	Tab Pos
	MHz	dBuV/m	dB	dBuV/m	dBuV/m	dB		cm	Deg
1	10479.97	42.97	12.87	55.84	68.30	-12.46	Peak	116	267

Notes:

1. Result = Read Value + Factor
2. Factor = Antenna Factor + Cable Loss - Amplifier
3. The resolution bandwidth of test receiver/spectrum analyzer is 120KHz and video bandwidth is 300kHz for Peak detection and Quasi-peak detection at frequency below 1GHz.
4. The resolution bandwidth of test receiver/spectrum analyzer is 1MHz and video bandwidth is 3MHz for Peak detection at frequency above 1GHz.
5. The resolution bandwidth of test receiver/spectrum analyzer is 1MHz and video bandwidth is 10Hz for Average detection at frequency above 1GHz.
6. The other emissions is too low to be measured.



Power	: AC 120V	Pol/Phase	: VERTICAL
Test Mode 2	: 802.11an HT20, CH36	Temperature	: 22 °C
Memo	:	Humidity	: 70 %

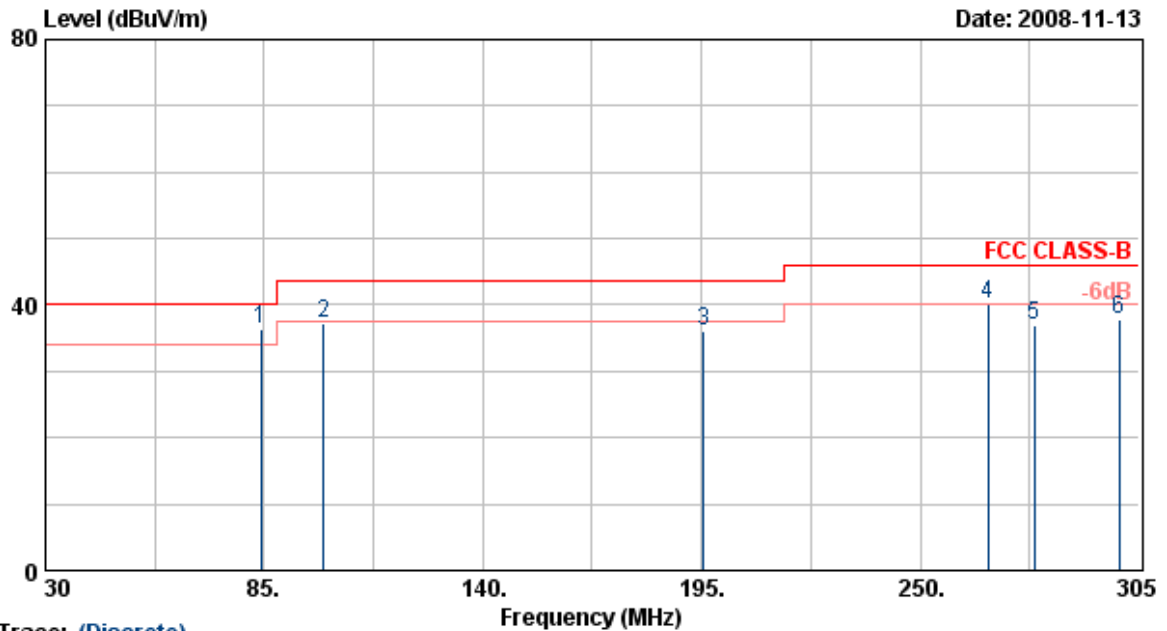

Trace: (Discrete)

Item	Freq	Read Value	Factor	Result	Limit	Margin	Remark	Ant Pos	Tab Pos
	MHz	dBuV/m	dB	dBuV/m	dBuV/m	dB		cm	Deg
1	84.18	53.45	-16.94	36.51	40.00	-3.49	QP	100	154
2	99.85	51.67	-14.37	37.30	43.50	-6.20	Peak	100	88
3	195.55	47.25	-11.12	36.13	43.50	-7.37	Peak	100	62
4	267.05	48.66	-8.47	40.20	46.00	-5.80	QP	100	102
5	278.60	44.15	-7.10	37.05	46.00	-8.95	Peak	100	122
6	300.05	47.44	-9.49	37.95	46.00	-8.05	Peak	100	88

Notes:

1. Result = Read Value + Factor
2. Factor = Antenna Factor + Cable Loss - Amplifier
3. The resolution bandwidth of test receiver/spectrum analyzer is 120KHz and video bandwidth is 300kHz for Peak detection and Quasi-peak detection at frequency below 1GHz.
4. According to technical experiences, all spurious emission of 802.11an HT20 mode at channel 36,44,48 are almost the same below 1GHz, so that the channel 36 was chosen as representative in final test.
5. The data is worse case.



Power	: AC 120V	Pol/Phase	: VERTICAL
Test Mode 2	: 802.11an HT20, CH36	Temperature	: 22 °C
Memo	:	Humidity	: 70 %

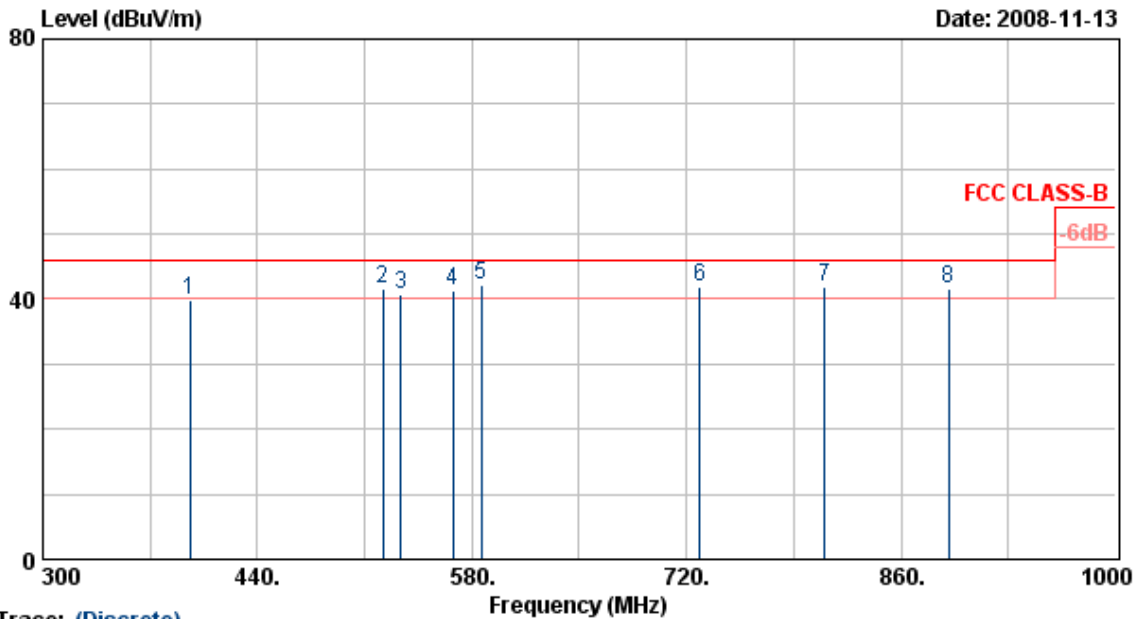

Trace: (Discrete)

Item	Freq	Read Value	Factor	Result	Limit	Margin	Remark	Ant Pos	Tab Pos
	MHz	dBuV/m	dB	dBuV/m	dBuV/m	dB		cm	Deg
1	395.90	47.13	-7.20	39.92	46.00	-6.08	Peak	100	92
2	521.90	45.89	-4.18	41.71	46.00	-4.29	QP	100	80
3	533.80	44.56	-3.83	40.73	46.00	-5.27	QP	100	105
4	567.40	39.91	1.35	41.25	46.00	-4.75	QP	100	147
5	586.30	42.56	-0.36	42.20	46.00	-3.80	QP	100	82
6	728.40	39.01	2.80	41.81	46.00	-4.19	QP	100	103
7	810.30	44.56	-2.62	41.94	46.00	-4.06	QP	100	105
8	890.80	39.83	1.72	41.55	46.00	-4.45	QP	100	99

Notes:

1. Result = Read Value + Factor
2. Factor = Antenna Factor + Cable Loss - Amplifier
3. The resolution bandwidth of test receiver/spectrum analyzer is 120KHz and video bandwidth is 300kHz for Peak detection and Quasi-peak detection at frequency below 1GHz.
4. According to technical experiences, all spurious emission of 802.11an HT20 mode at channel 36,44,48 are almost the same below 1GHz, so that the channel 36 was chosen as representative in final test.
5. The data is worse case.



Power	: AC 120V	Pol/Phase	: HORIZONTAL
Test Mode 2	: 802.11an HT20, CH36	Temperature	: 22 °C
Memo	:	Humidity	: 70 %

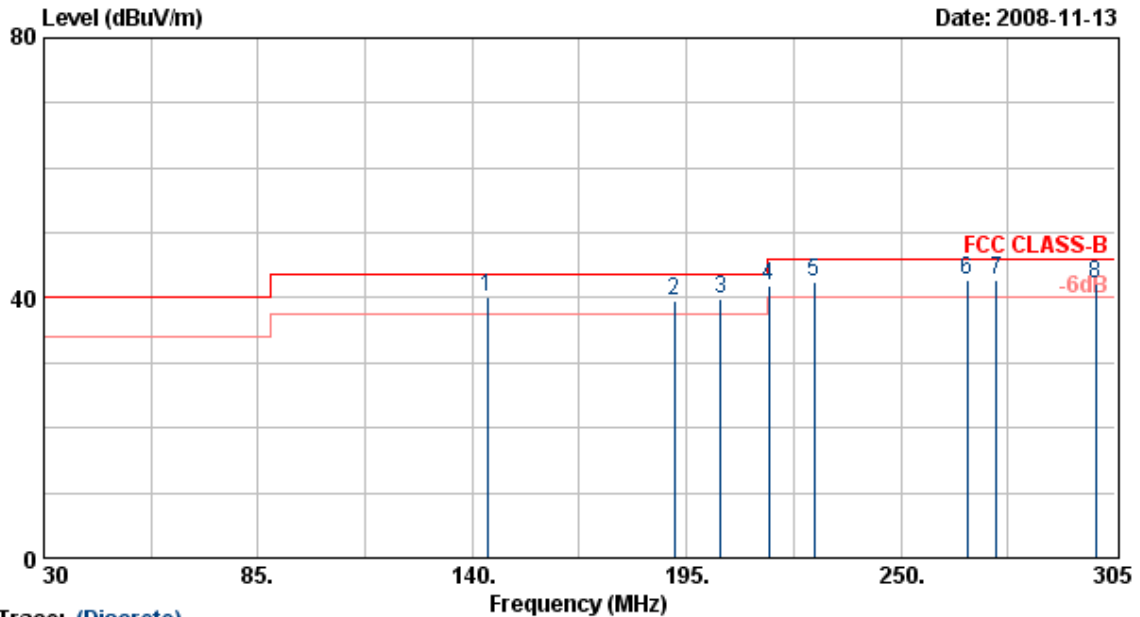

Trace: (Discrete)

Item	Freq MHz	Read Value dBuV/m	Factor dB	Result dBuV/m	Limit dBuV/m	Margin dB	Remark	Ant Pos cm	Tab Pos Deg
1	143.85	57.64	-17.51	40.13	43.50	-3.37	QP	100	102
2	191.98	56.17	-16.47	39.70	43.50	-3.80	QP	100	124
3	203.80	55.99	-15.99	40.00	43.50	-3.50	QP	100	108
4	216.18	60.20	-18.40	41.80	46.00	-4.20	QP	100	85
5	227.73	60.83	-18.26	42.57	46.00	-3.43	QP	100	75
6	267.05	58.13	-15.45	42.67	46.00	-3.33	QP	100	82
7	274.48	57.23	-14.57	42.65	46.00	-3.35	QP	100	122
8	300.05	56.54	-14.49	42.04	46.00	-3.96	QP	100	77

Notes:

1. Result = Read Value + Factor
2. Factor = Antenna Factor + Cable Loss - Amplifier
3. The resolution bandwidth of test receiver/spectrum analyzer is 120KHz and video bandwidth is 300kHz for Peak detection and Quasi-peak detection at frequency below 1GHz.
4. According to technical experiences, all spurious emission of 802.11an HT20 mode at channel 36,44,48 are almost the same below 1GHz, so that the channel 36 was chosen as representative in final test.
5. The data is worse case.



Power	: AC 120V	Pol/Phase	: HORIZONTAL
Test Mode 2	: 802.11an HT20, CH36	Temperature	: 22 °C
Memo	:	Humidity	: 70 %

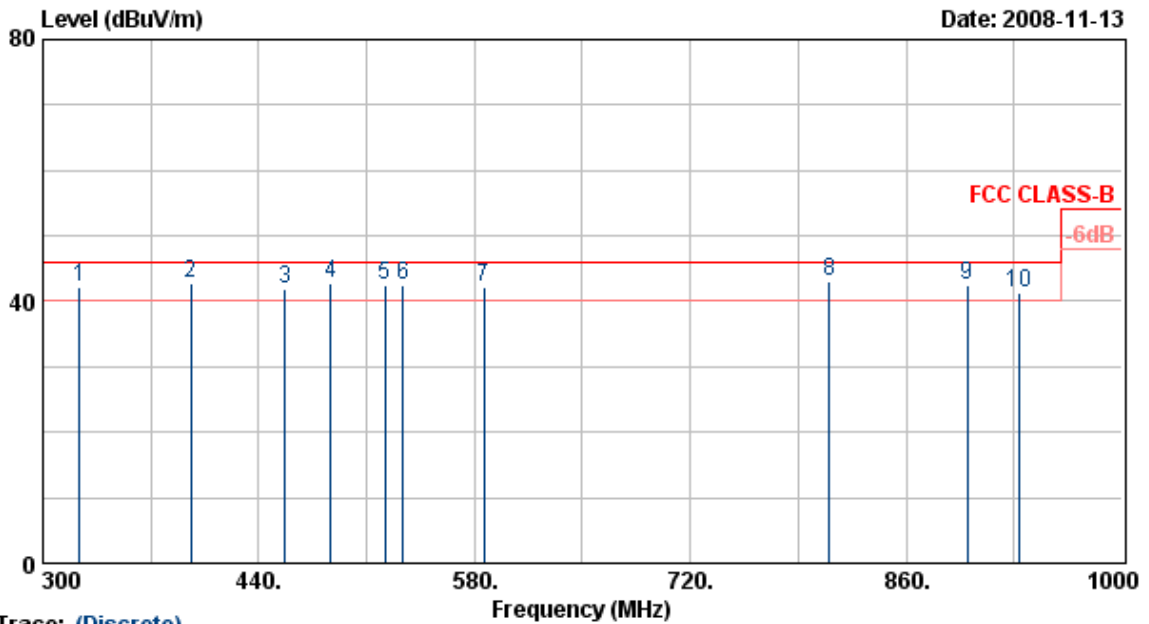

Trace: (Discrete)

Item	Freq	Read Value	Factor	Result	Limit	Margin	Remark	Ant Pos	Tab Pos
	MHz	dBuV/m	dB	dBuV/m	dBuV/m	dB		cm	Deg
1	323.80	54.97	-12.77	42.19	46.00	-3.81	QP	100	95
2	395.90	52.37	-9.52	42.85	46.00	-3.15	QP	100	111
3	456.80	50.58	-8.73	41.85	46.00	-4.15	QP	100	132
4	486.90	48.51	-5.70	42.80	46.00	-3.20	QP	100	145
5	521.90	46.22	-3.85	42.37	46.00	-3.63	QP	100	125
6	533.80	45.34	-2.88	42.46	46.00	-3.54	QP	100	86
7	586.30	44.64	-2.54	42.10	46.00	-3.90	QP	100	63
8	810.30	43.82	-0.87	42.95	46.00	-3.05	QP	100	123
9	899.90	38.74	3.86	42.59	46.00	-3.41	QP	100	99
10	932.80	36.22	5.06	41.27	46.00	-4.73	QP	100	122

Notes:

1. Result = Read Value + Factor
2. Factor = Antenna Factor + Cable Loss - Amplifier
3. The resolution bandwidth of test receiver/spectrum analyzer is 120KHz and video bandwidth is 300kHz for Peak detection and Quasi-peak detection at frequency below 1GHz.
4. According to technical experiences, all spurious emission of 802.11an HT20 mode at channel 36,44,48 are almost the same below 1GHz, so that the channel 36 was chosen as representative in final test.
5. The data is worse case.



Power	: AC 120V	Pol/Phase	: VERTICAL
Test Mode 2	: 802.11an HT20, CH36	Temperature	: 22 °C
Memo	:	Humidity	: 70 %

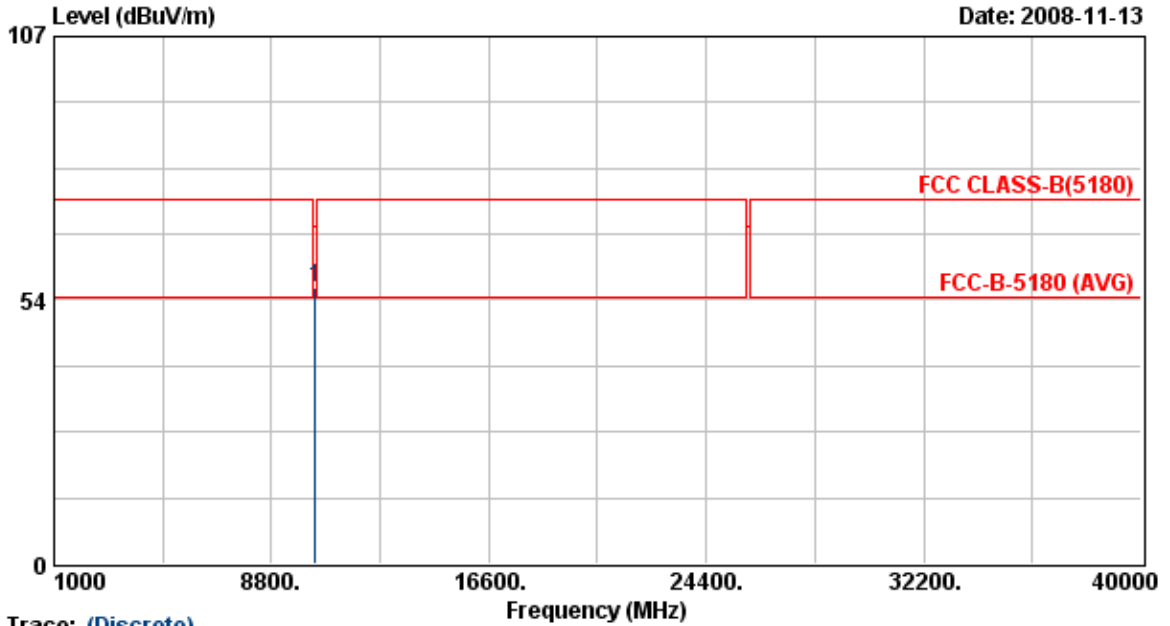

Trace: (Discrete)

Item	Freq	Read Value	Factor	Result	Limit	Margin	Remark	Ant Pos	Tab Pos
	MHz	dBuV/m	dB	dBuV/m	dBuV/m	dB		cm	Deg
1	10360.25	43.45	12.68	56.13	68.30	-12.17	Peak	116	267

Notes:

1. Result = Read Value + Factor
2. Factor = Antenna Factor + Cable Loss - Amplifier
3. The resolution bandwidth of test receiver/spectrum analyzer is 120KHz and video bandwidth is 300kHz for Peak detection and Quasi-peak detection at frequency below 1GHz.
4. The resolution bandwidth of test receiver/spectrum analyzer is 1MHz and video bandwidth is 3MHz for Peak detection at frequency above 1GHz.
5. The resolution bandwidth of test receiver/spectrum analyzer is 1MHz and video bandwidth is 10Hz for Average detection at frequency above 1GHz.
6. The other emissions is too low to be measured.



Power	: AC 120V	Pol/Phase	: HORIZONTAL
Test Mode 2	: 802.11an HT20, CH36	Temperature	: 22 °C
Memo	:	Humidity	: 70 %

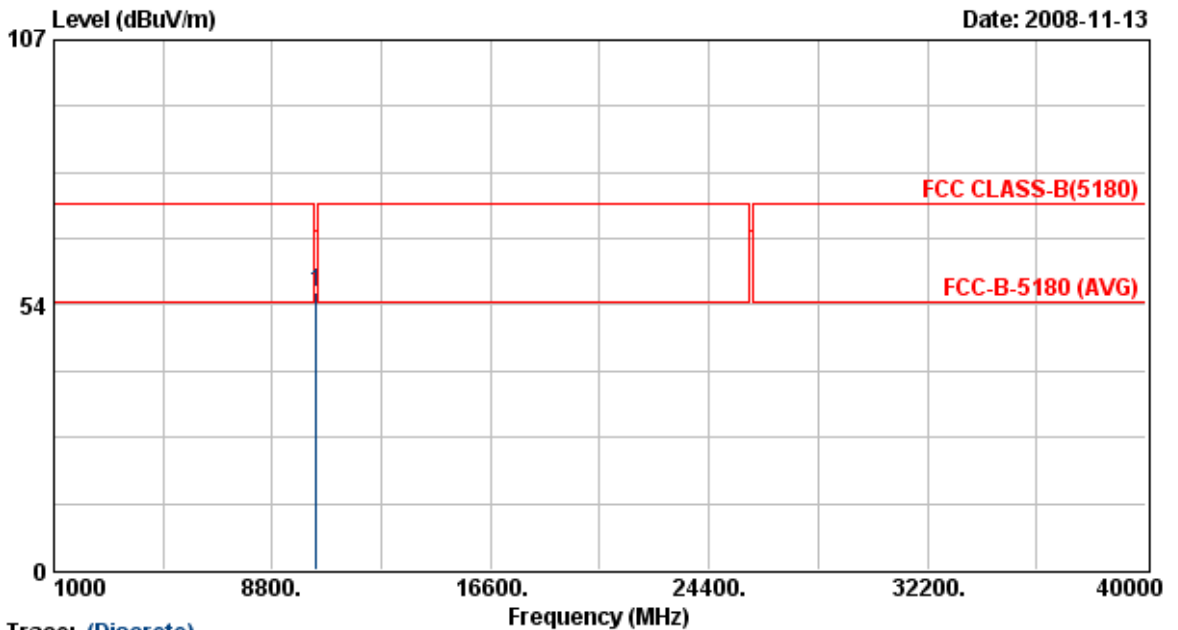

Trace: (Discrete)

Item	Freq	Read Value	Factor	Result	Limit	Margin	Remark	Ant Pos	Tab Pos
	MHz	dBuV/m	dB	dBuV/m	dBuV/m	dB		cm	Deg
1	10360.25	43.53	12.68	56.20	68.30	-12.10	Peak	116	267

Notes:

1. Result = Read Value + Factor
2. Factor = Antenna Factor + Cable Loss - Amplifier
3. The resolution bandwidth of test receiver/spectrum analyzer is 120KHz and video bandwidth is 300kHz for Peak detection and Quasi-peak detection at frequency below 1GHz.
4. The resolution bandwidth of test receiver/spectrum analyzer is 1MHz and video bandwidth is 3MHz for Peak detection at frequency above 1GHz.
5. The resolution bandwidth of test receiver/spectrum analyzer is 1MHz and video bandwidth is 10Hz for Average detection at frequency above 1GHz.
6. The other emissions is too low to be measured.



Power	: AC 120V	Pol/Phase	: VERTICAL
Test Mode 2	: 802.11an HT20, CH44	Temperature	: 22 °C
Memo	:	Humidity	: 70 %

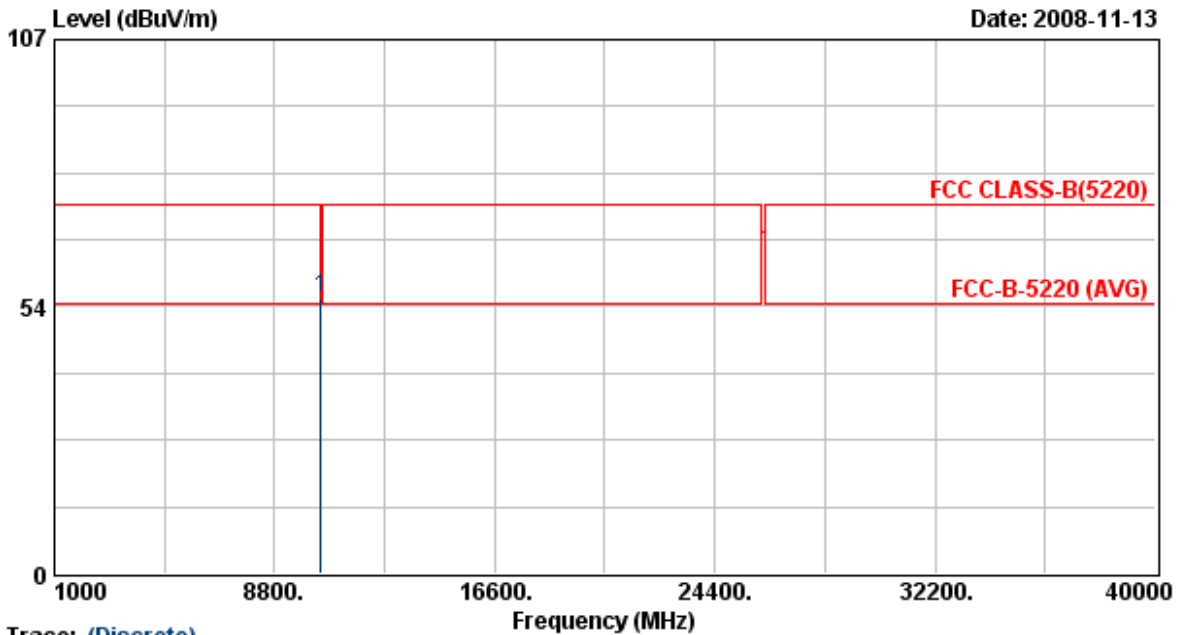

Trace: (Discrete)

Item	Freq	Read Value	Factor	Result	Limit	Margin	Remark	Ant Pos	Tab Pos
	MHz	dBuV/m	dB	dBuV/m	dBuV/m	dB		cm	Deg
1	10439.95	42.34	12.80	55.15	68.30	-13.15	Peak	116	267

Notes:

1. Result = Read Value + Factor
2. Factor = Antenna Factor + Cable Loss - Amplifier
3. The resolution bandwidth of test receiver/spectrum analyzer is 120KHz and video bandwidth is 300kHz for Peak detection and Quasi-peak detection at frequency below 1GHz.
4. The resolution bandwidth of test receiver/spectrum analyzer is 1MHz and video bandwidth is 3MHz for Peak detection at frequency above 1GHz.
5. The resolution bandwidth of test receiver/spectrum analyzer is 1MHz and video bandwidth is 10Hz for Average detection at frequency above 1GHz.
6. The other emissions is too low to be measured.



Power	: AC 120V	Pol/Phase	: VERTICAL
Test Mode 2	: 802.11an HT20, CH44	Temperature	: 22 °C
Memo	:	Humidity	: 70 %

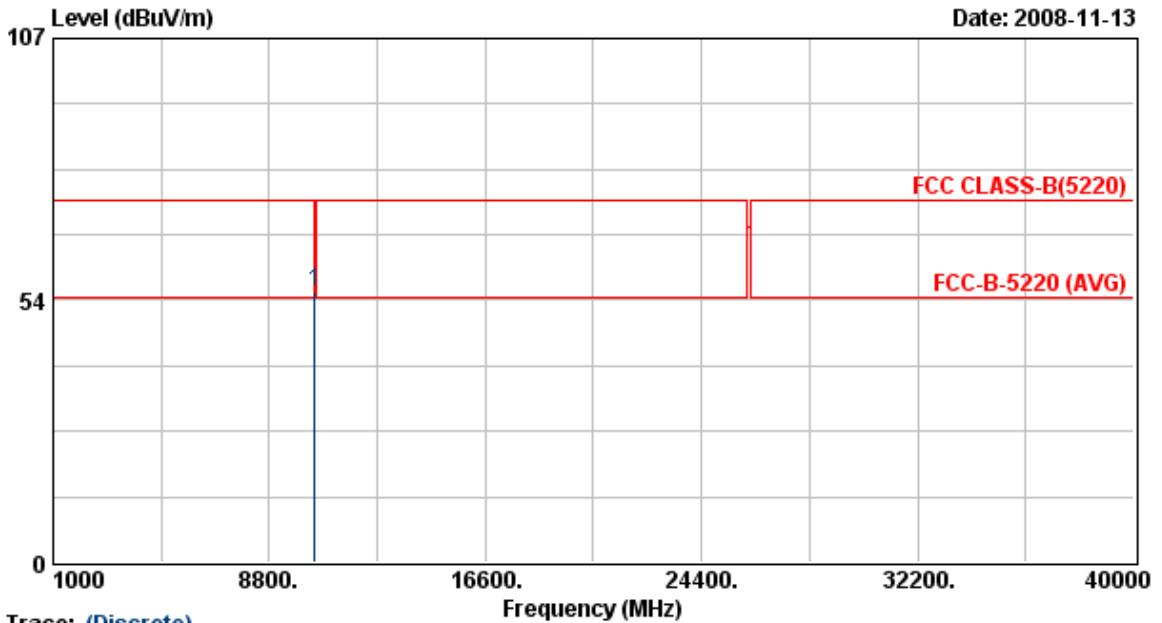

Trace: (Discrete)

Item	Freq	Read Value	Factor	Result	Limit	Margin	Remark	Ant Pos	Tab Pos
	MHz	dBuV/m	dB	dBuV/m	dBuV/m	dB		cm	Deg
1	10439.95	42.32	12.80	55.12	68.30	-13.18	Peak	116	267

Notes:

1. Result = Read Value + Factor
2. Factor = Antenna Factor + Cable Loss - Amplifier
3. The resolution bandwidth of test receiver/spectrum analyzer is 120KHz and video bandwidth is 300kHz for Peak detection and Quasi-peak detection at frequency below 1GHz.
4. The resolution bandwidth of test receiver/spectrum analyzer is 1MHz and video bandwidth is 3MHz for Peak detection at frequency above 1GHz.
5. The resolution bandwidth of test receiver/spectrum analyzer is 1MHz and video bandwidth is 10Hz for Average detection at frequency above 1GHz.
6. The other emissions is too low to be measured.



Power	: AC 120V	Pol/Phase	: VERTICAL
Test Mode 2	: 802.11an HT20, CH48	Temperature	: 22 °C
Memo	:	Humidity	: 70 %

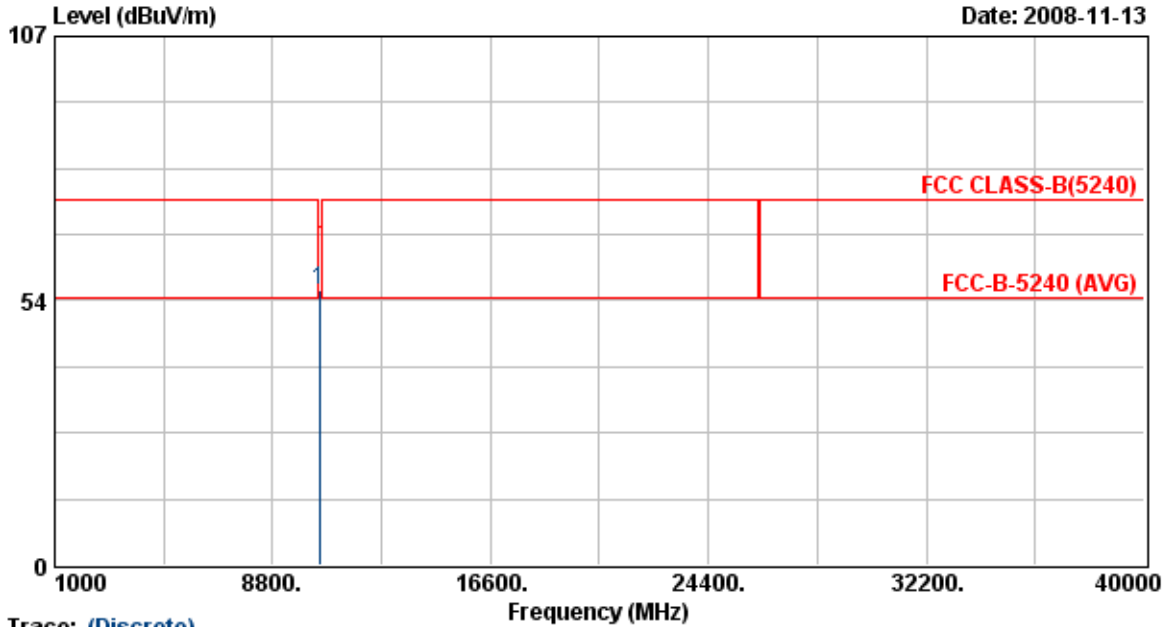

Trace: (Discrete)

Item	Freq	Read Value	Factor	Result	Limit	Margin	Remark	Ant Pos	Tab Pos
	MHz	dBuV/m	dB	dBuV/m	dBuV/m	dB		cm	Deg
1	10479.97	42.90	12.87	55.76	68.30	-12.54	Peak	116	267

Notes:

1. Result = Read Value + Factor
2. Factor = Antenna Factor + Cable Loss - Amplifier
3. The resolution bandwidth of test receiver/spectrum analyzer is 120KHz and video bandwidth is 300kHz for Peak detection and Quasi-peak detection at frequency below 1GHz.
4. The resolution bandwidth of test receiver/spectrum analyzer is 1MHz and video bandwidth is 3MHz for Peak detection at frequency above 1GHz.
5. The resolution bandwidth of test receiver/spectrum analyzer is 1MHz and video bandwidth is 10Hz for Average detection at frequency above 1GHz.
6. The other emissions is too low to be measured.



Power	: AC 120V	Pol/Phase	: HORIZONTAL
Test Mode 2	: 802.11an HT20, CH36	Temperature	: 22 °C
Memo	:	Humidity	: 70 %

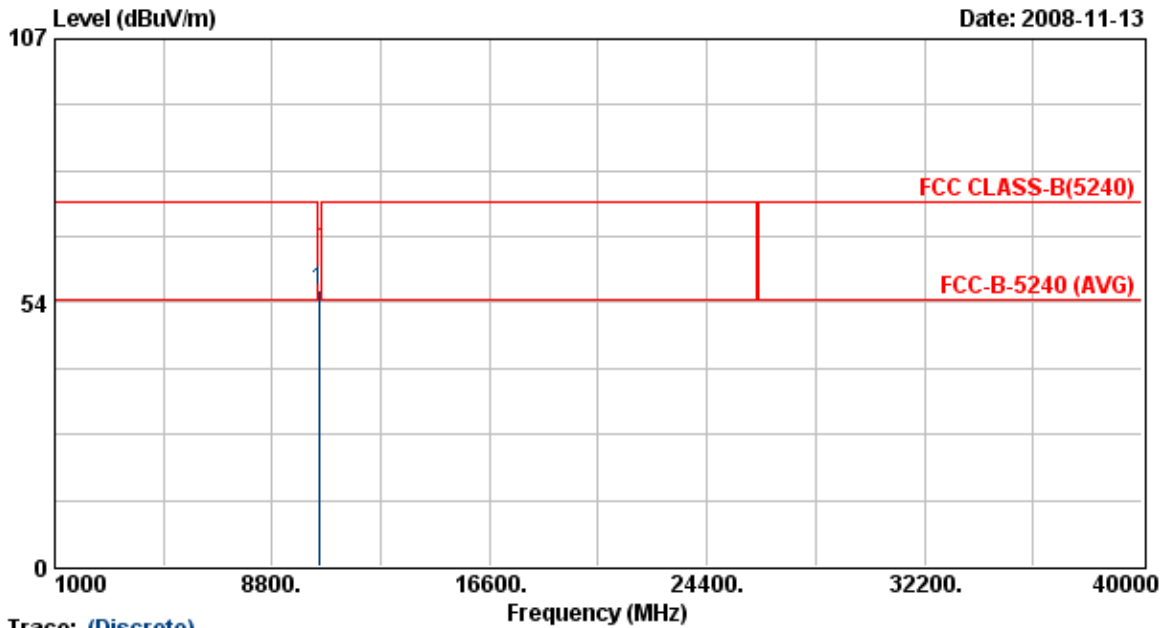

Trace: (Discrete)

Item	Freq	Read Value	Factor	Result	Limit	Margin	Remark	Ant Pos	Tab Pos
	MHz	dBuV/m	dB	dBuV/m	dBuV/m	dB		cm	Deg
1	10479.97	42.97	12.87	55.84	68.30	-12.46	Peak	116	267

Notes:

1. Result = Read Value + Factor
2. Factor = Antenna Factor + Cable Loss - Amplifier
3. The resolution bandwidth of test receiver/spectrum analyzer is 120KHz and video bandwidth is 300kHz for Peak detection and Quasi-peak detection at frequency below 1GHz.
4. The resolution bandwidth of test receiver/spectrum analyzer is 1MHz and video bandwidth is 3MHz for Peak detection at frequency above 1GHz.
5. The resolution bandwidth of test receiver/spectrum analyzer is 1MHz and video bandwidth is 10Hz for Average detection at frequency above 1GHz.
6. The other emissions is too low to be measured.



Power	: AC 120V	Pol/Phase	: VERTICAL
Test Mode 3	: 802.11an HT40, CH38	Temperature	: 22 °C
Memo	:	Humidity	: 70 %

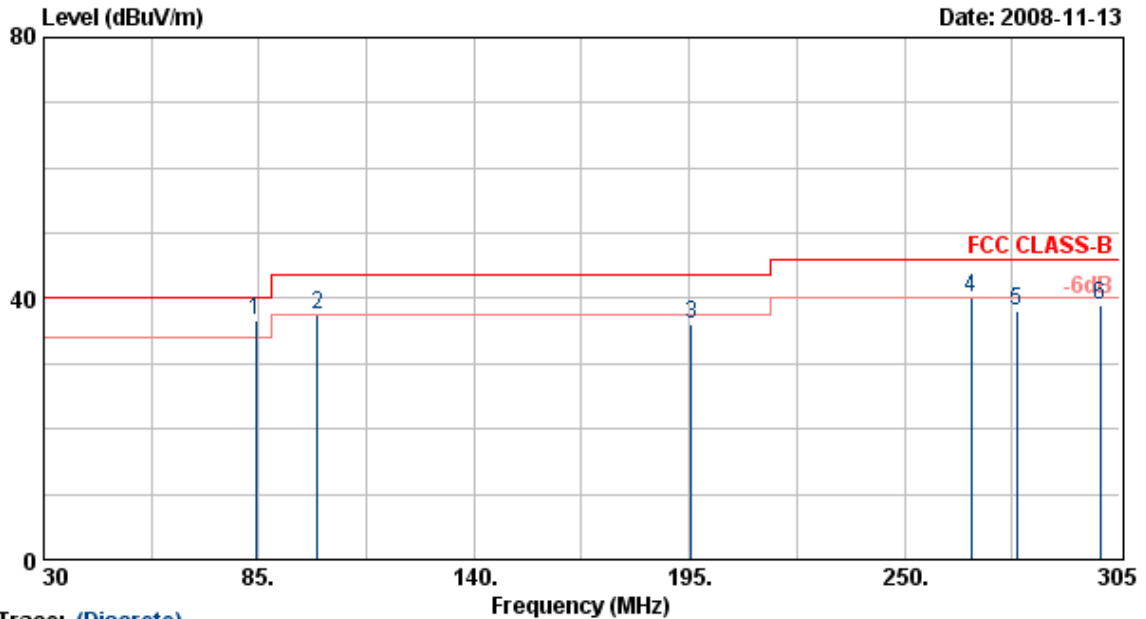

Trace: (Discrete)

Item	Freq	Read Value	Factor	Result	Limit	Margin	Remark	Ant Pos	Tab Pos
	MHz	dBuV/m	dB	dBuV/m	dBuV/m	dB		cm	Deg
1	84.18	53.66	-16.94	36.73	40.00	-3.27	QP	100	154
2	99.85	51.85	-14.37	37.48	43.50	-6.02	Peak	100	88
3	195.55	47.25	-11.12	36.13	43.50	-7.37	Peak	100	62
4	267.05	48.55	-8.47	40.09	46.00	-5.91	QP	100	102
5	278.60	45.11	-7.10	38.01	46.00	-7.99	Peak	100	122
6	300.05	48.46	-9.49	38.97	46.00	-7.03	Peak	100	88

Notes:

1. Result = Read Value + Factor
2. Factor = Antenna Factor + Cable Loss - Amplifier
3. The resolution bandwidth of test receiver/spectrum analyzer is 120KHz and video bandwidth is 300kHz for Peak detection and Quasi-peak detection at frequency below 1GHz.
4. According to technical experiences, all spurious emission of 802.11an HT40 mode at channel 38,42,46 are almost the same below 1GHz, so that the channel 38 was chosen as representative in final test.
5. The data is worse case.



Power	: AC 120V	Pol/Phase	: VERTICAL
Test Mode 3	: 802.11an HT40, CH38	Temperature	: 22 °C
Memo	:	Humidity	: 70 %

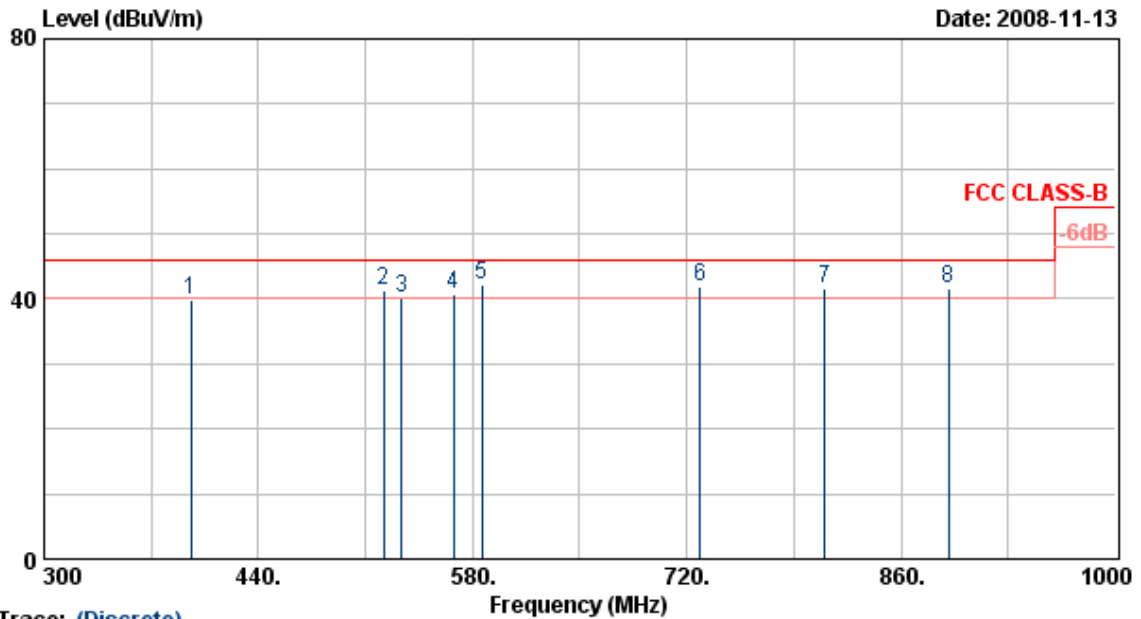

Trace: (Discrete)

Item	Freq	Read Value	Factor	Result	Limit	Margin	Remark	Ant Pos	Tab Pos
	MHz	dBuV/m	dB	dBuV/m	dBuV/m	dB		cm	Deg
1	395.90	47.18	-7.20	39.98	46.00	-6.02	Peak	100	92
2	521.90	45.36	-4.18	41.18	46.00	-4.82	QP	100	80
3	533.80	43.89	-3.83	40.05	46.00	-5.95	QP	100	105
4	567.40	39.32	1.35	40.67	46.00	-5.33	QP	100	147
5	586.30	42.61	-0.36	42.25	46.00	-3.75	QP	100	82
6	728.40	39.21	2.80	42.01	46.00	-3.99	QP	100	103
7	810.30	44.33	-2.62	41.71	46.00	-4.29	QP	100	105
8	890.80	39.82	1.72	41.54	46.00	-4.46	QP	100	99

Notes:

1. Result = Read Value + Factor
2. Factor = Antenna Factor + Cable Loss - Amplifier
3. The resolution bandwidth of test receiver/spectrum analyzer is 120KHz and video bandwidth is 300kHz for Peak detection and Quasi-peak detection at frequency below 1GHz.
4. According to technical experiences, all spurious emission of 802.11an HT40 mode at channel 38,42,46 are almost the same below 1GHz, so that the channel 38 was chosen as representative in final test.
5. The data is worse case.



Power	: AC 120V	Pol/Phase	: HORIZONTAL
Test Mode 3	: 802.11an HT40, CH38	Temperature	: 22 °C
Memo	:	Humidity	: 70 %

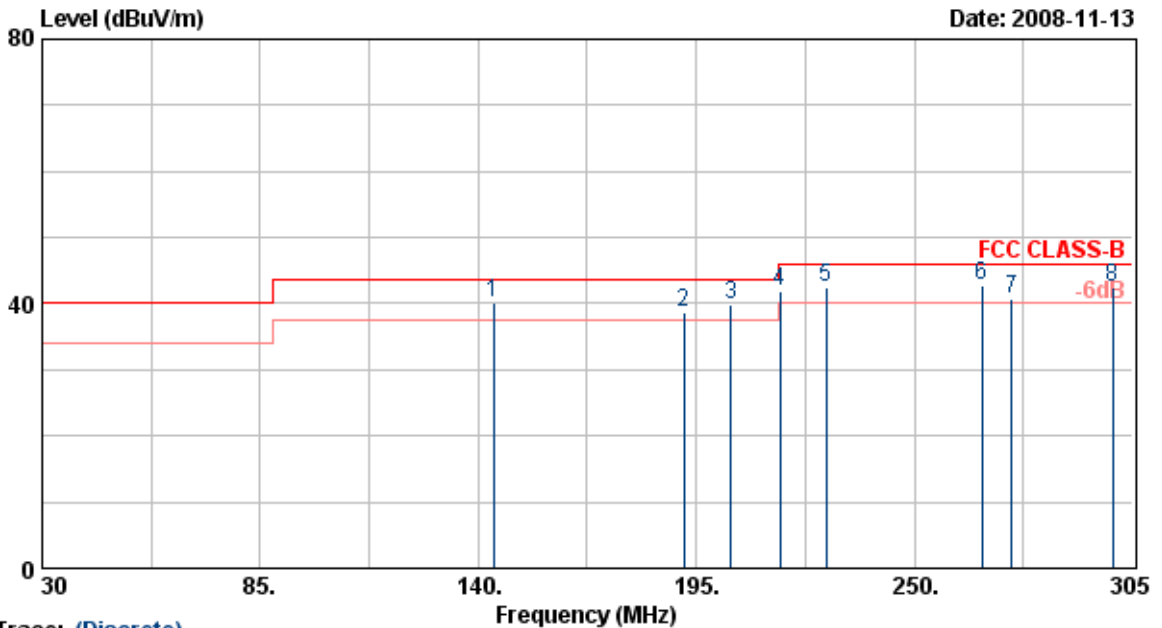

Trace: (Discrete)

Item	Freq	Read Value	Factor	Result	Limit	Margin	Remark	Ant Pos	Tab Pos
	MHz	dBuV/m	dB	dBuV/m	dBuV/m	dB		cm	Deg
1	143.85	57.64	-17.51	40.13	43.50	-3.37	QP	100	102
2	191.98	55.19	-16.47	38.72	43.50	-4.78	QP	100	124
3	203.80	55.70	-15.99	39.71	43.50	-3.79	QP	100	108
4	216.18	60.20	-18.40	41.80	46.00	-4.20	QP	100	85
5	227.73	60.80	-18.26	42.54	46.00	-3.46	QP	100	75
6	267.05	58.21	-15.45	42.76	46.00	-3.24	QP	100	82
7	274.48	55.20	-14.57	40.62	46.00	-5.38	QP	100	122
8	300.05	56.95	-14.49	42.46	46.00	-3.54	QP	100	77

Notes:

1. Result = Read Value + Factor
2. Factor = Antenna Factor + Cable Loss - Amplifier
3. The resolution bandwidth of test receiver/spectrum analyzer is 120KHz and video bandwidth is 300kHz for Peak detection and Quasi-peak detection at frequency below 1GHz.
4. According to technical experiences, all spurious emission of 802.11an HT40 mode at channel 38,42,46 are almost the same below 1GHz, so that the channel 38 was chosen as representative in final test.
5. The data is worse case.



Power	: AC 120V	Pol/Phase	: HORIZONTAL
Test Mode 3	: 802.11an HT40, CH38	Temperature	: 22 °C
Memo	:	Humidity	: 70 %

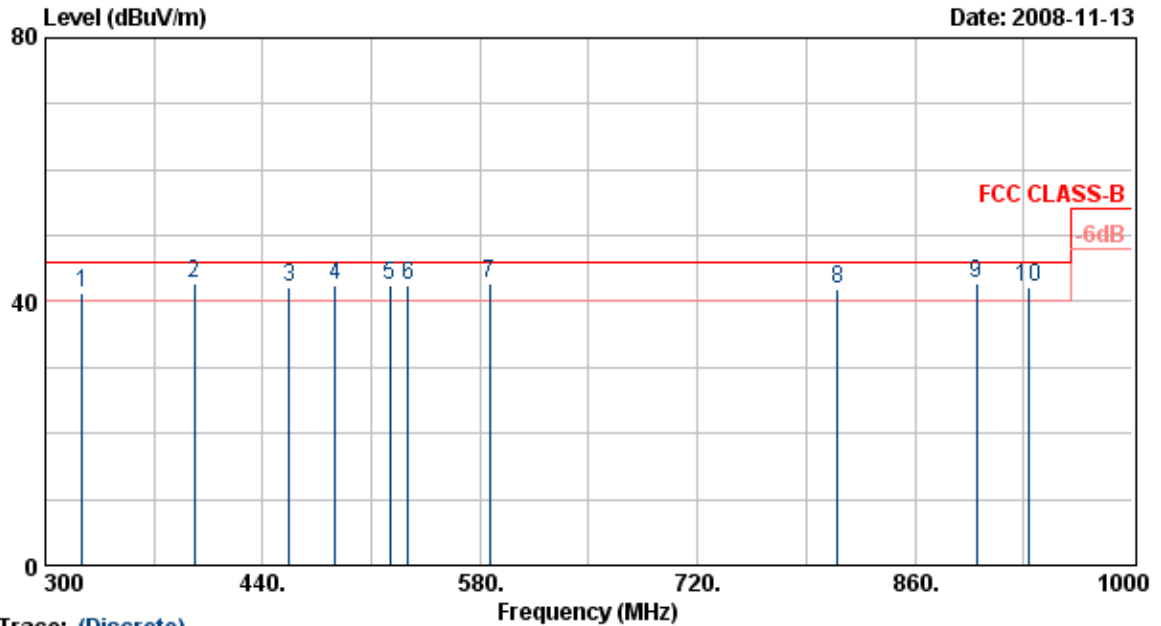

Trace: (Discrete)

Item	Freq	Read Value	Factor	Result	Limit	Margin	Remark	Ant Pos	Tab Pos
	MHz	dBuV/m	dB	dBuV/m	dBuV/m	dB		cm	Deg
1	323.80	53.94	-12.77	41.16	46.00	-4.84	QP	100	95
2	395.90	52.30	-9.52	42.77	46.00	-3.23	QP	100	111
3	456.80	50.96	-8.73	42.23	46.00	-3.77	QP	100	132
4	486.90	48.11	-5.70	42.40	46.00	-3.60	QP	100	145
5	521.90	46.20	-3.85	42.35	46.00	-3.65	QP	100	125
6	533.80	45.46	-2.88	42.58	46.00	-3.42	QP	100	86
7	586.30	45.34	-2.54	42.80	46.00	-3.20	QP	100	63
8	810.30	42.83	-0.87	41.96	46.00	-4.04	QP	100	123
9	899.90	38.80	3.86	42.65	46.00	-3.35	QP	100	99
10	932.80	37.22	5.06	42.27	46.00	-3.73	QP	100	122

Notes:

1. Result = Read Value + Factor
2. Factor = Antenna Factor + Cable Loss - Amplifier
3. The resolution bandwidth of test receiver/spectrum analyzer is 120KHz and video bandwidth is 300kHz for Peak detection and Quasi-peak detection at frequency below 1GHz.
4. According to technical experiences, all spurious emission of 802.11an HT40 mode at channel 38, 42, 46 are almost the same below 1GHz, so that the channel 38 was chosen as representative in final test.
5. The data is worse case.



Power	: AC 120V	Pol/Phase	: VERTICAL
Test Mode 3	: 802.11an HT40, CH38	Temperature	: 22 °C
Memo	:	Humidity	: 70 %

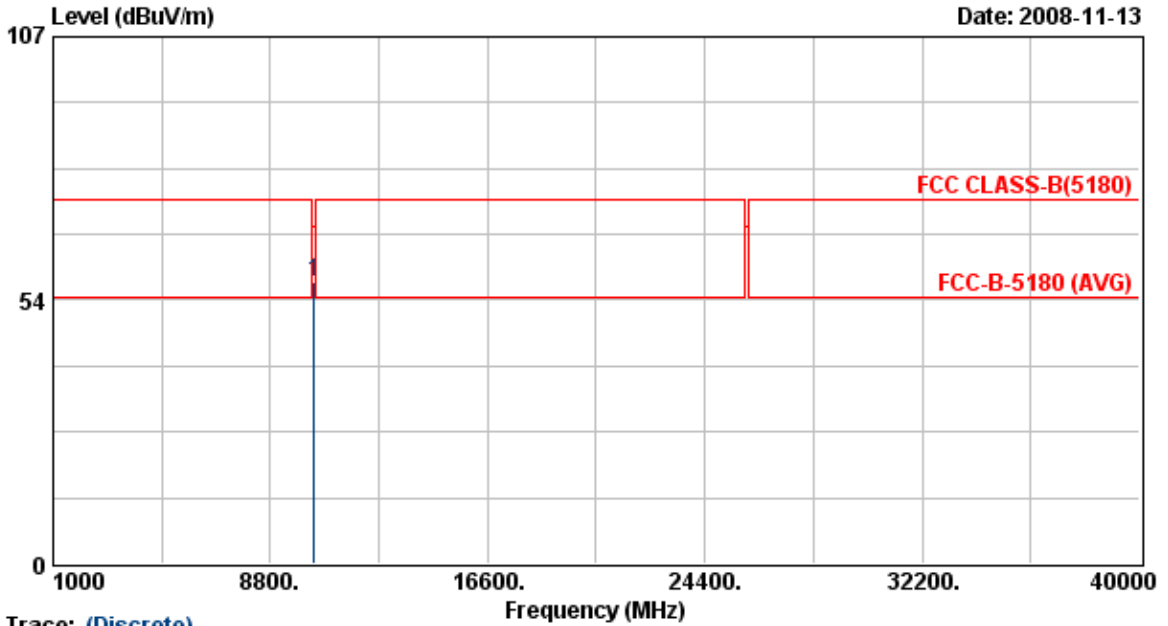

Trace: (Discrete)

Item	Freq	Read Value	Factor	Result	Limit	Margin	Remark	Ant Pos	Tab Pos
	MHz	dBuV/m	dB	dBuV/m	dBuV/m	dB		cm	Deg
1	10380.25	44.42	12.71	57.13	68.30	-11.17	Peak	116	267

Notes:

1. Result = Read Value + Factor
2. Factor = Antenna Factor + Cable Loss - Amplifier
3. The resolution bandwidth of test receiver/spectrum analyzer is 120KHz and video bandwidth is 300kHz for Peak detection and Quasi-peak detection at frequency below 1GHz.
4. The resolution bandwidth of test receiver/spectrum analyzer is 1MHz and video bandwidth is 3MHz for Peak detection at frequency above 1GHz.
5. The resolution bandwidth of test receiver/spectrum analyzer is 1MHz and video bandwidth is 10Hz for Average detection at frequency above 1GHz.
6. The other emissions is too low to be measured.



Power	: AC 120V	Pol/Phase	: HORIZONTAL
Test Mode 3	: 802.11an HT40, CH38	Temperature	: 22 °C
Memo	:	Humidity	: 70 %

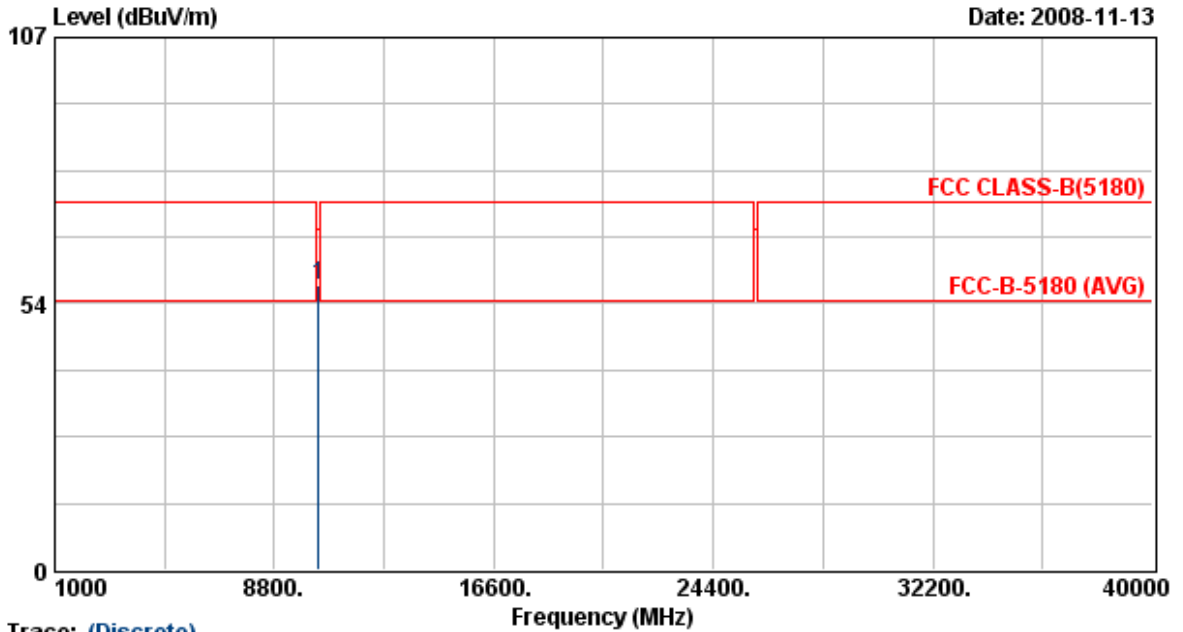

Trace: (Discrete)

Item	Freq	Read Value	Factor	Result	Limit	Margin	Remark	Ant Pos	Tab Pos
	MHz	dBuV/m	dB	dBuV/m	dBuV/m	dB		cm	Deg
1	10380.25	44.41	12.71	57.12	68.30	-11.18	Peak	116	267

Notes:

1. Result = Read Value + Factor
2. Factor = Antenna Factor + Cable Loss - Amplifier
3. The resolution bandwidth of test receiver/spectrum analyzer is 120KHz and video bandwidth is 300kHz for Peak detection and Quasi-peak detection at frequency below 1GHz.
4. The resolution bandwidth of test receiver/spectrum analyzer is 1MHz and video bandwidth is 3MHz for Peak detection at frequency above 1GHz.
5. The resolution bandwidth of test receiver/spectrum analyzer is 1MHz and video bandwidth is 10Hz for Average detection at frequency above 1GHz.
6. The other emissions is too low to be measured.



Power	: AC 120V	Pol/Phase	: VERTICAL
Test Mode 3	: 802.11an HT40, CH46	Temperature	: 22 °C
Memo	:	Humidity	: 70 %

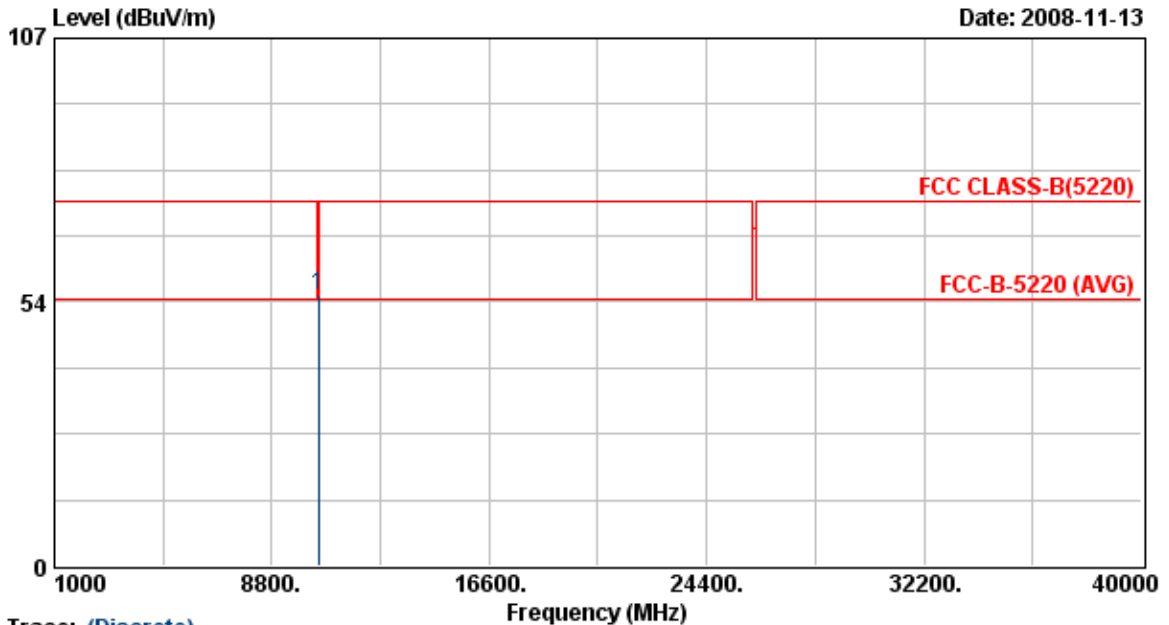

Trace: (Discrete)

Item	Freq	Read Value	Factor	Result	Limit	Margin	Remark	Ant Pos	Tab Pos
	MHz	dBuV/m	dB	dBuV/m	dBuV/m	dB		cm	Deg
1	10459.97	41.93	12.84	54.76	68.30	-13.54	Peak	116	267

Notes:

1. Result = Read Value + Factor
2. Factor = Antenna Factor + Cable Loss - Amplifier
3. The resolution bandwidth of test receiver/spectrum analyzer is 120KHz and video bandwidth is 300kHz for Peak detection and Quasi-peak detection at frequency below 1GHz.
4. The resolution bandwidth of test receiver/spectrum analyzer is 1MHz and video bandwidth is 3MHz for Peak detection at frequency above 1GHz.
5. The resolution bandwidth of test receiver/spectrum analyzer is 1MHz and video bandwidth is 10Hz for Average detection at frequency above 1GHz.
6. The other emissions is too low to be measured.



Power	: AC 120V	Pol/Phase	: HORIZONTAL
Test Mode 3	: 802.11an HT40, CH46	Temperature	: 22 °C
Memo	:	Humidity	: 70 %

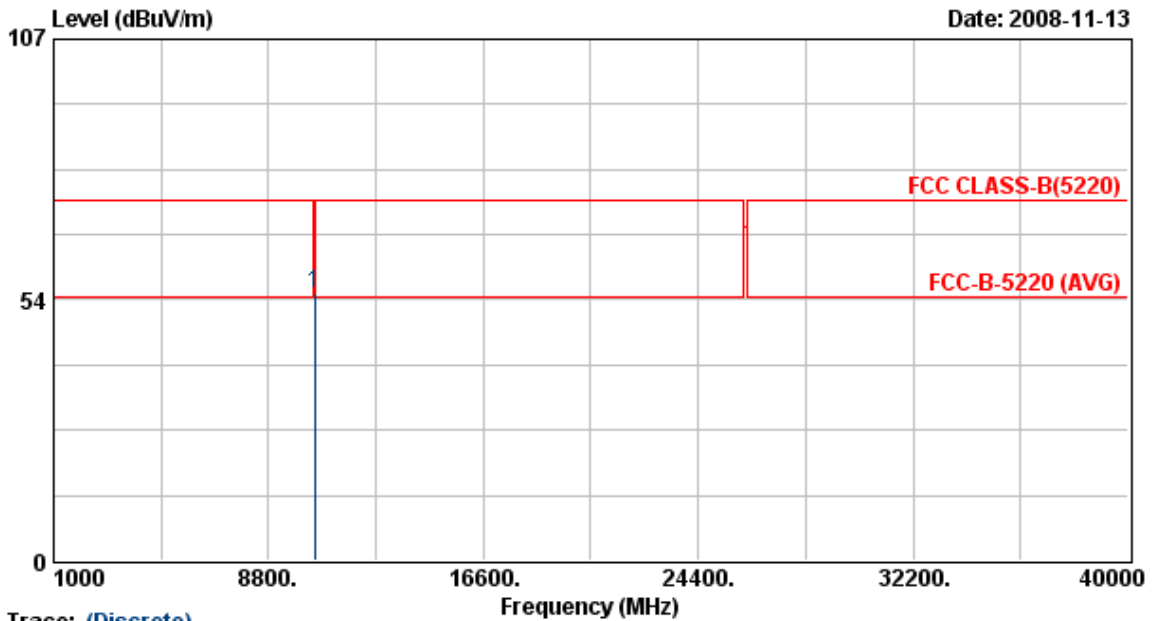

Trace: (Discrete)

Item	Freq	Read Value	Factor	Result	Limit	Margin	Remark	Ant Pos	Tab Pos
	MHz	dBuV/m	dB	dBuV/m	dBuV/m	dB		cm	Deg
1	10459.97	41.99	12.84	54.82	68.30	-13.48	Peak	116	267

Notes:

1. Result = Read Value + Factor
2. Factor = Antenna Factor + Cable Loss - Amplifier
3. The resolution bandwidth of test receiver/spectrum analyzer is 120KHz and video bandwidth is 300kHz for Peak detection and Quasi-peak detection at frequency below 1GHz.
4. The resolution bandwidth of test receiver/spectrum analyzer is 1MHz and video bandwidth is 3MHz for Peak detection at frequency above 1GHz.
5. The resolution bandwidth of test receiver/spectrum analyzer is 1MHz and video bandwidth is 10Hz for Average detection at frequency above 1GHz.
6. The other emissions is too low to be measured.

Test engineer: Ben



6. Peak Transmit Power

6.1. Test Procedure

The antenna port (RF output) of the EUT was connected to the input (RF input) of a spectrum analyzer. Power was read directly from the spectrum analyzer and cable loss connection was added to the reading to obtain power at the EUT antenna terminal. The EUT Output Power was set to maximum to produce the worse case test result.

6.2. Test Setup Layout

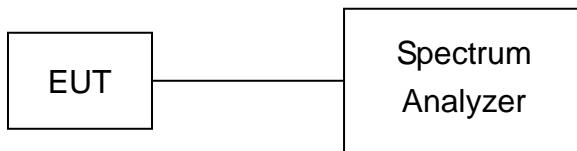

6.3. Measurement Equipment

Instrument/Ancillary	Model No.	Manufacturer	Serial No.	Calibration Date	Valid Date.
Spectrum Analyzer	FSP40	R&S	10047	2008/02/22	2009/02/21



6.4. Test Result and Data

Test Date: Nov. 08, 2008

Temperature: 20

Atmospheric pressure: 1008 hPa

Humidity: 60%

Modulation Standard: IEEE 802.11a (6Mbps)

Channel	Frequency (MHz)	Peak Power Output (dBm)		Peak Power Output (mW)		26dB Occupied Bandwidth (MHz)	
		L	R	L	R	L	R
36	5180	12.73	13.72	18.70	23.60	20.20	20.30
44	5220	14.05	14.93	25.40	31.10	20.00	20.20
48	5240	14.63	15.24	29.00	34.20	20.00	20.10

Modulation Standard: IEEE 802.11an HT20 (6.5Mbps)

Channel	Frequency (MHz)	Peak Power Output (dBm)			Peak Power Output (mW)	26dB Occupied Bandwidth (MHz)	
		L	R	L + R	L + R	L	R
36	5180	10.17	11.05	13.64	23.13	20.40	20.60
44	5220	10.52	11.83	14.23	26.51	20.30	20.40
48	5240	11.09	10.88	14.00	25.10	20.30	20.40

Modulation Standard: IEEE 802.11an HT40 (13.5Mbps)

Channel	Frequency (MHz)	Peak Power Output (dBm)			Peak Power Output (mW)	26dB Occupied Bandwidth (MHz)	
		L	R	L + R	L + R	L	R
38	5190	11.40	11.06	14.24	26.57	40.00	40.00
46	5230	11.34	10.38	13.90	24.53	40.00	40.00



Peak Transmit Power

Modulation Standard: 802.11a (6Mbps), Antenna: L
Channel: 36

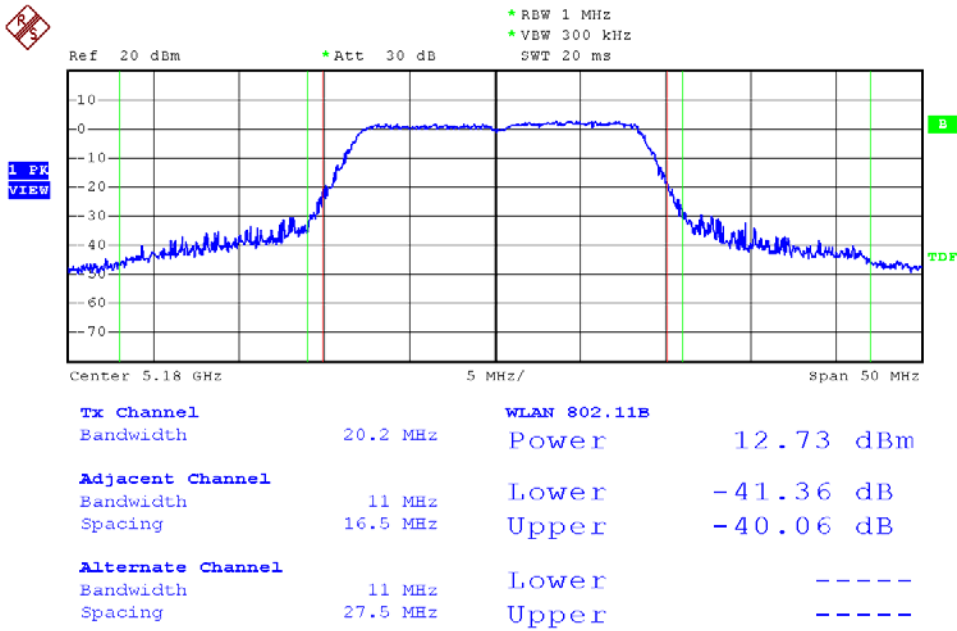

Modulation Standard: 802.11a (6Mbps), Antenna: L
Channel: 44

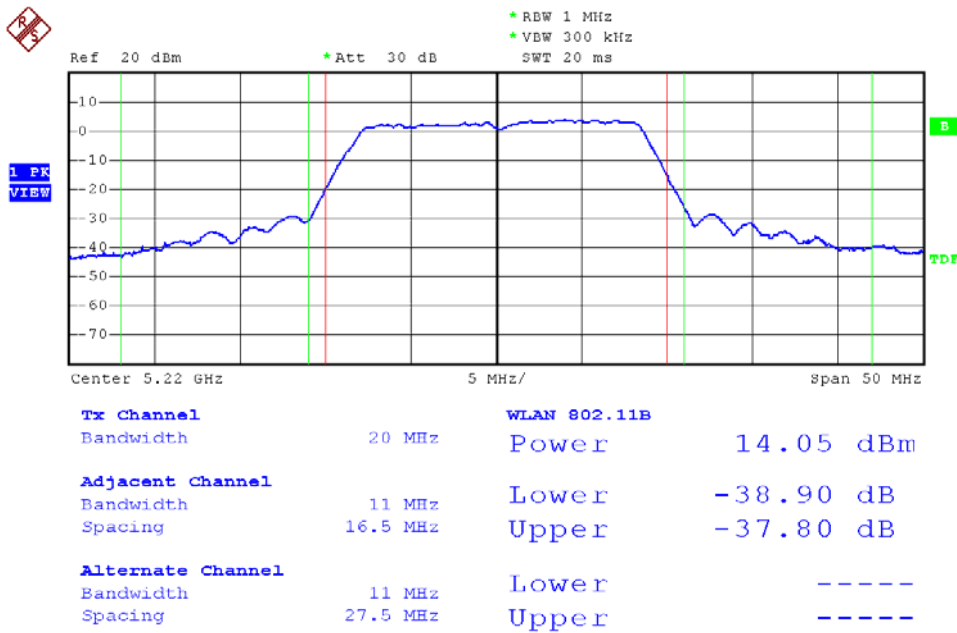



Modulation Standard: 802.11a (6Mbps), Antenna: L
Channel: 48

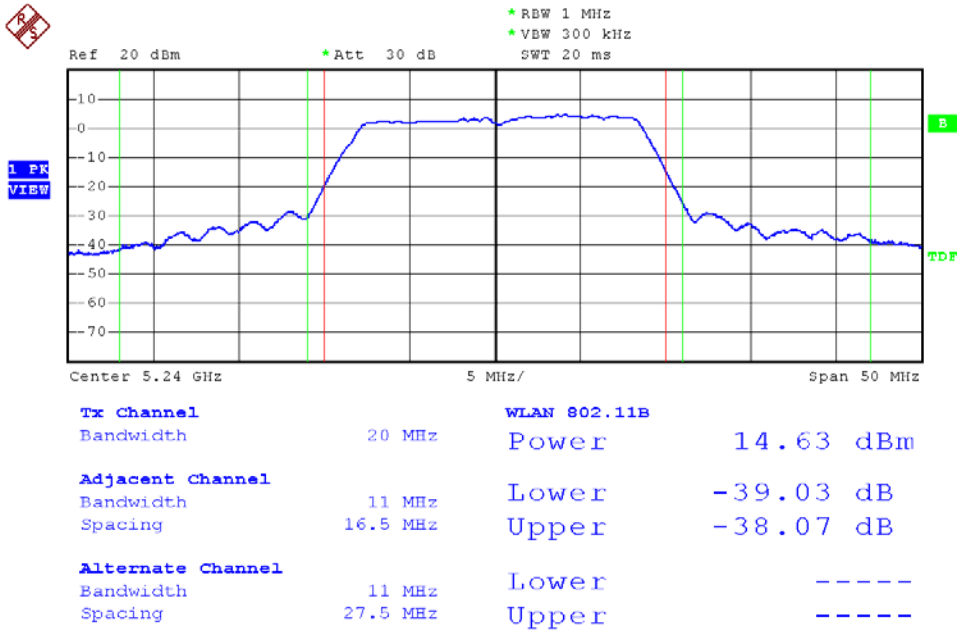

Modulation Standard: 802.11a (6Mbps), Antenna: R
Channel: 36

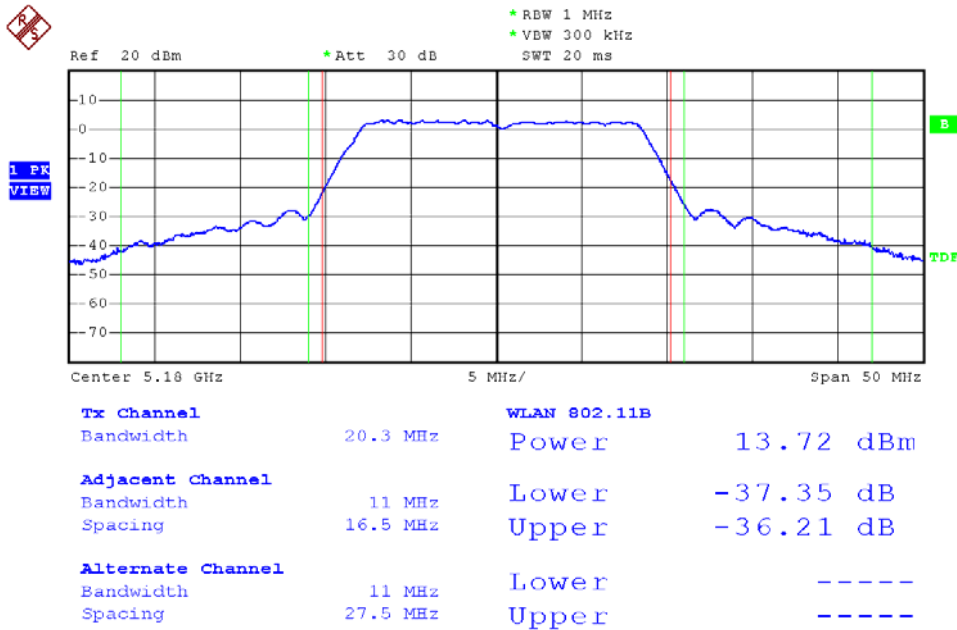



Modulation Standard: 802.11a (6Mbps), Antenna: R
Channel: 44

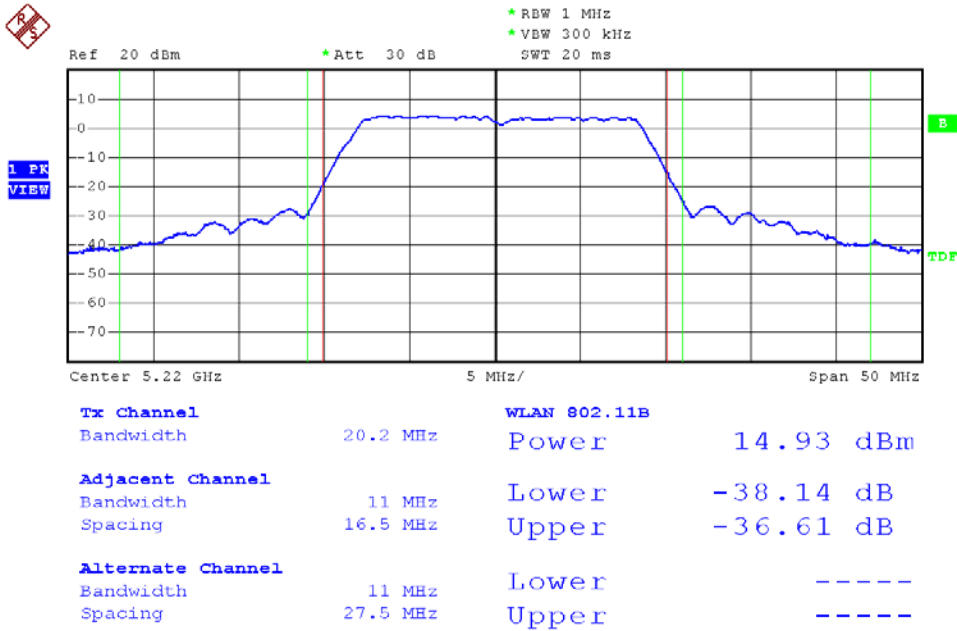

Modulation Standard: 802.11a (6Mbps), Antenna: R
Channel: 48

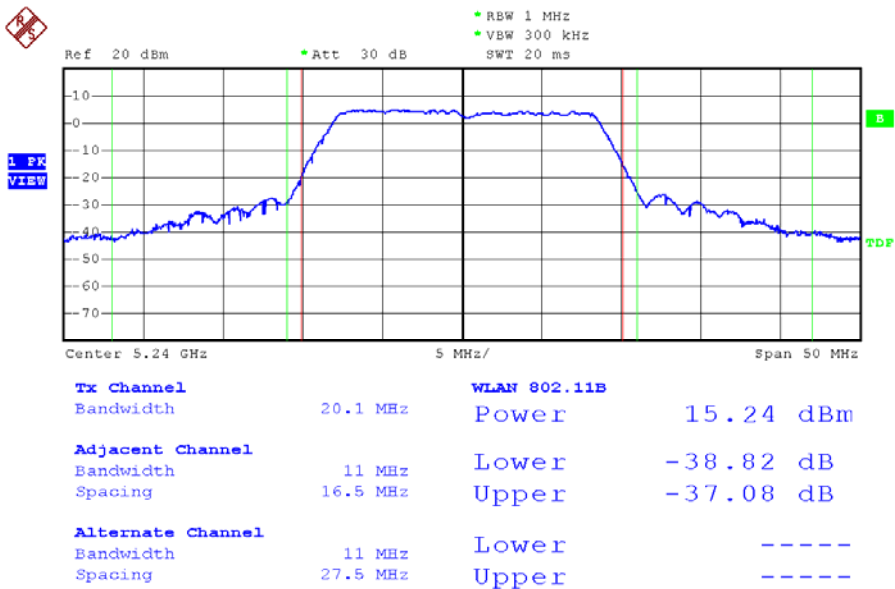



Modulation Standard: 802.11an HT20 (6.5Mbps), Antenna: L
Channel: 36

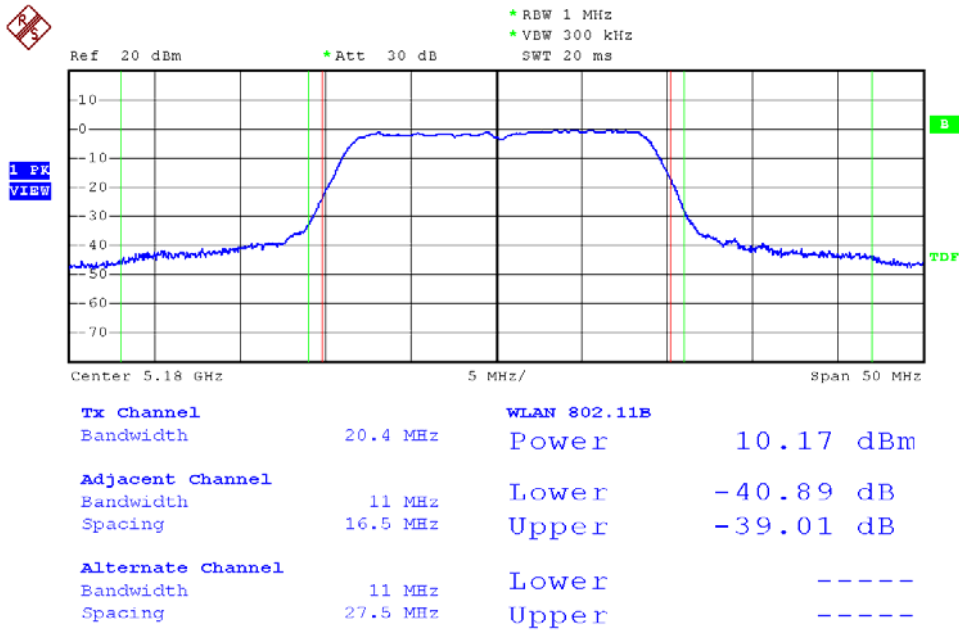

Modulation Standard: 802.11an HT20 (6.5Mbps), Antenna: L
Channel: 44

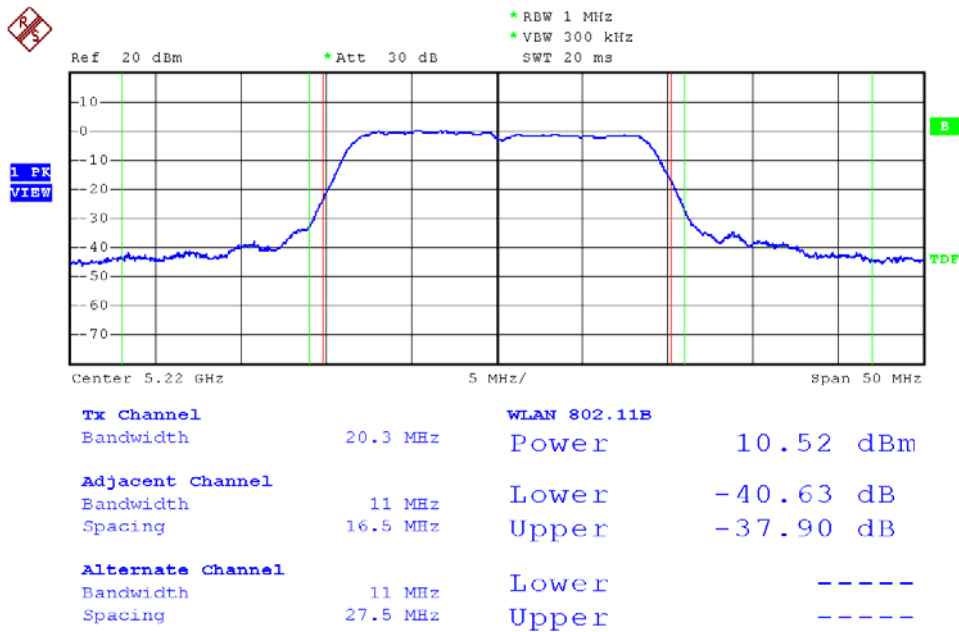



Modulation Standard: 802.11an HT20 (6.5Mbps), Antenna: L
Channel: 48

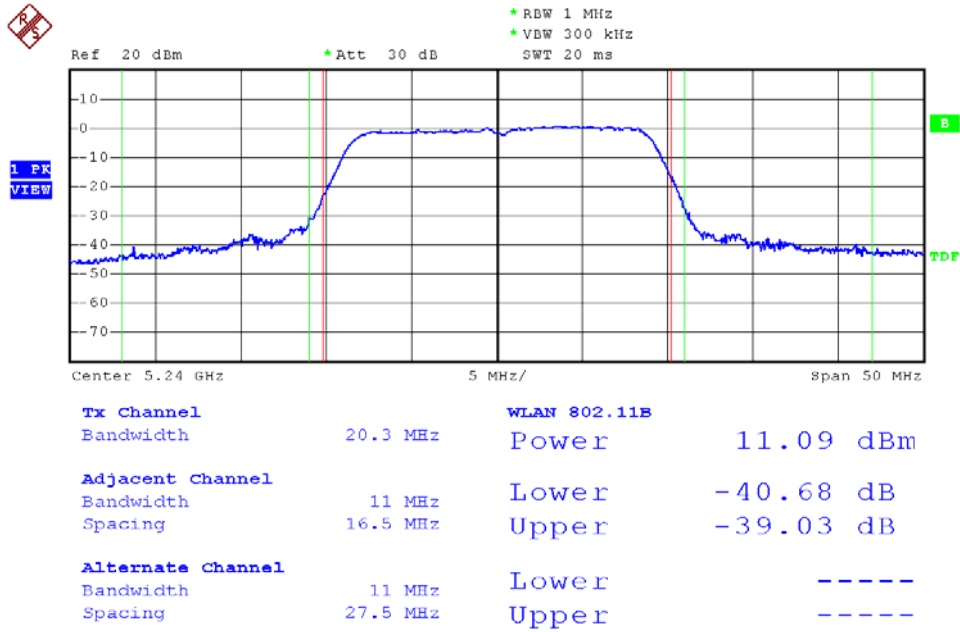

Modulation Standard: 802.11an HT20 (6.5Mbps), Antenna: R
Channel: 36

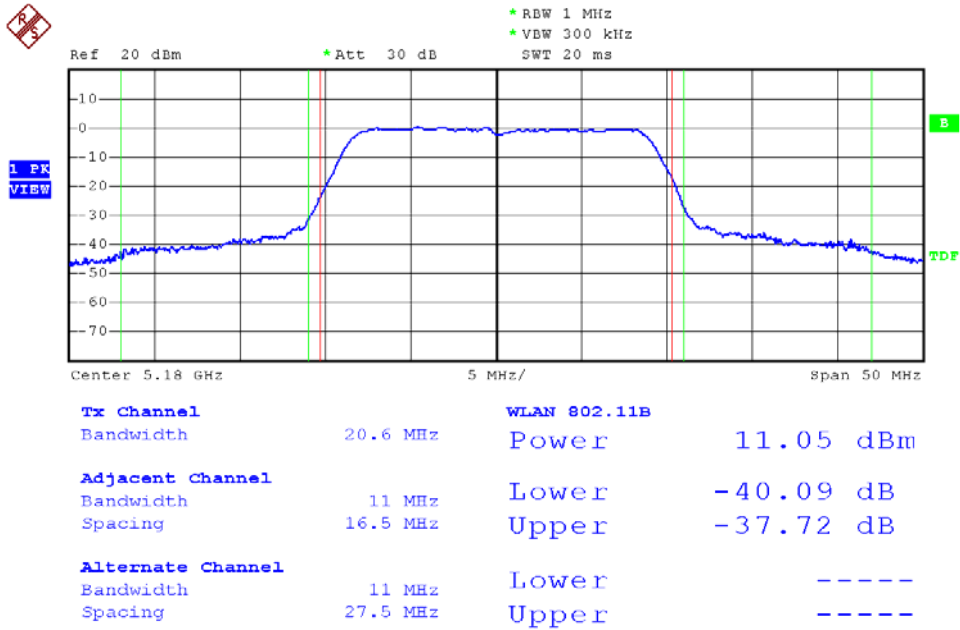



Modulation Standard: 802.11an HT20 (6.5Mbps), Antenna: R
Channel: 44

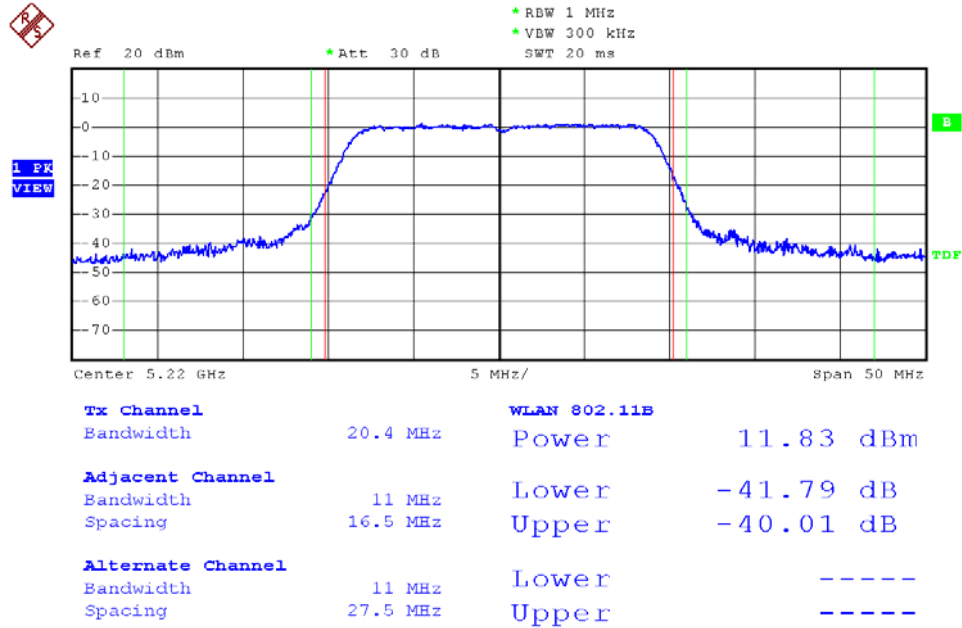

Modulation Standard: 802.11an HT20 (6.5Mbps), Antenna: R
Channel: 48

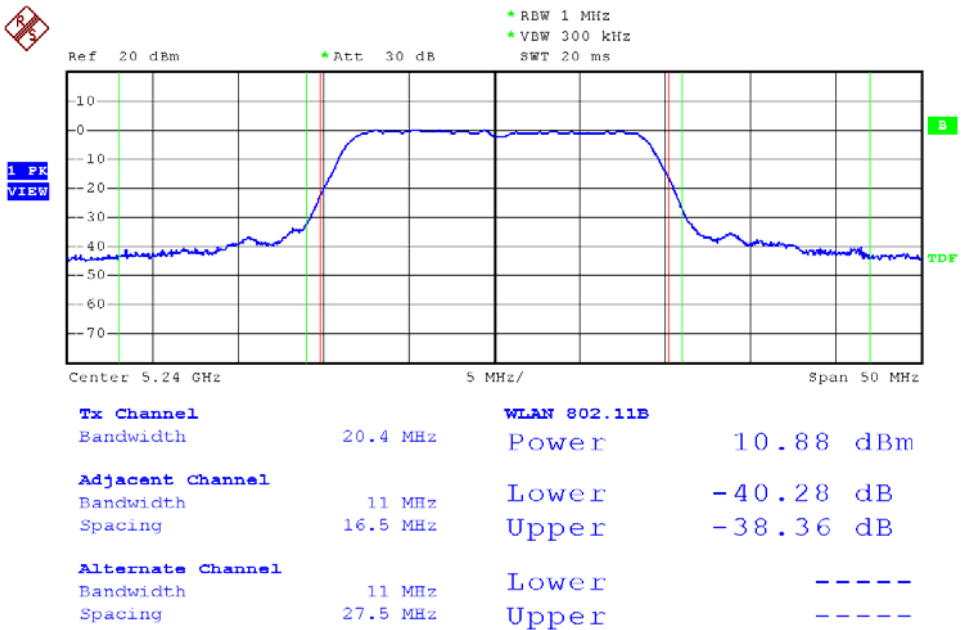



Modulation Standard: 802.11an HT40 (13.5Mbps), Antenna: L
Channel: 38

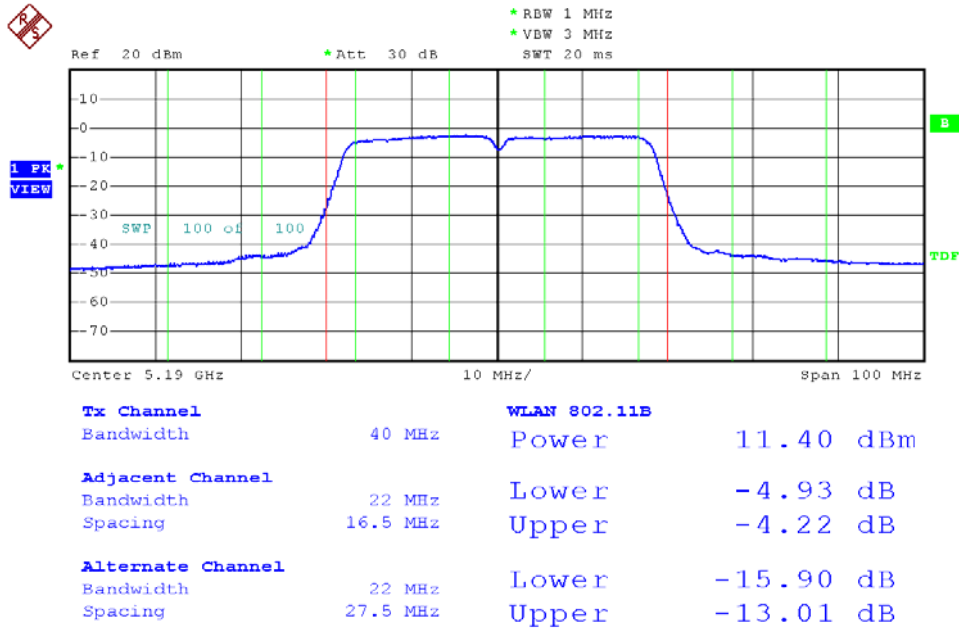

Modulation Standard: 802.11an HT40 (13.5Mbps), Antenna: L
Channel: 46

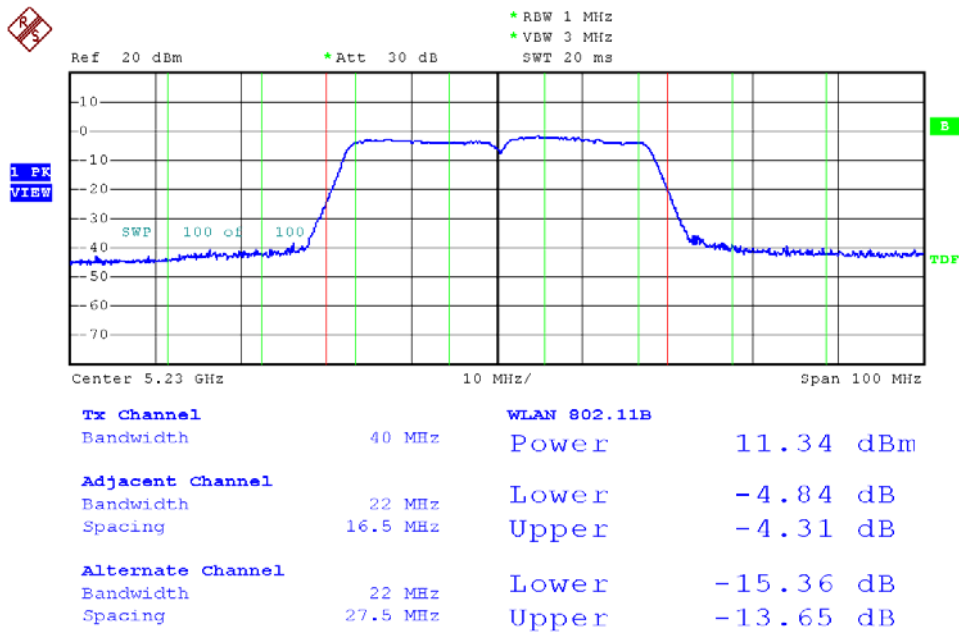



Modulation Standard: 802.11an HT40 (13.5Mbps), Antenna: R
Channel: 38

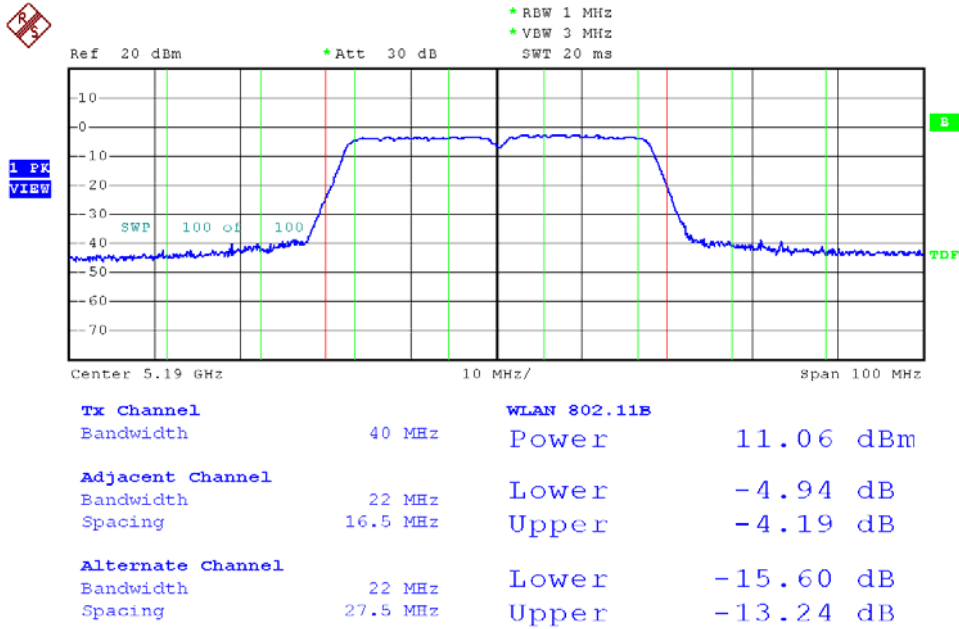

Modulation Standard: 802.11an HT40 (13.5Mbps), Antenna: R
Channel: 46

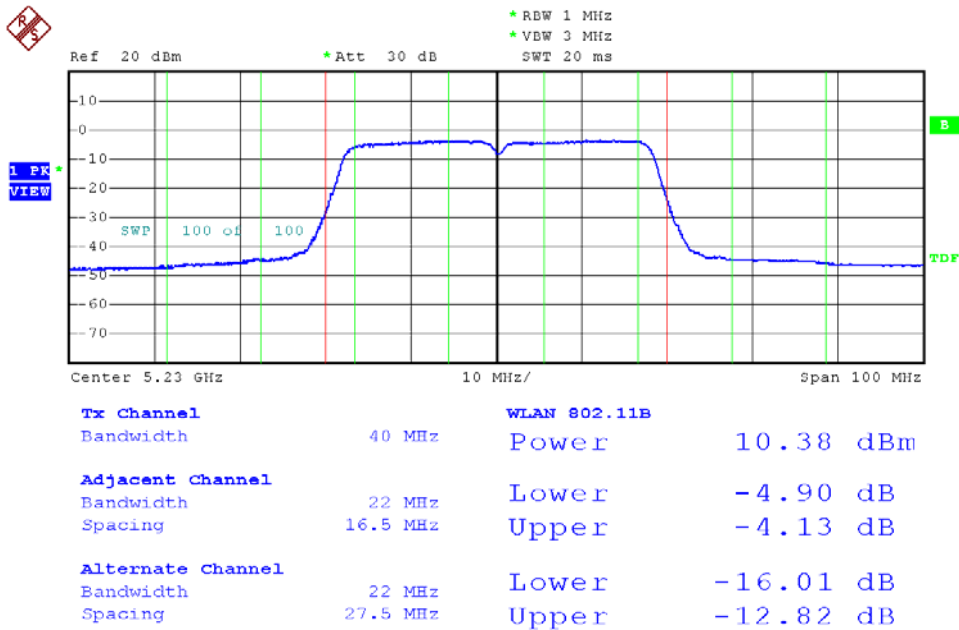



26dB Occupied Bandwidth

Modulation Standard: 802.11a (6Mbps), Antenna: L
Channel: 36

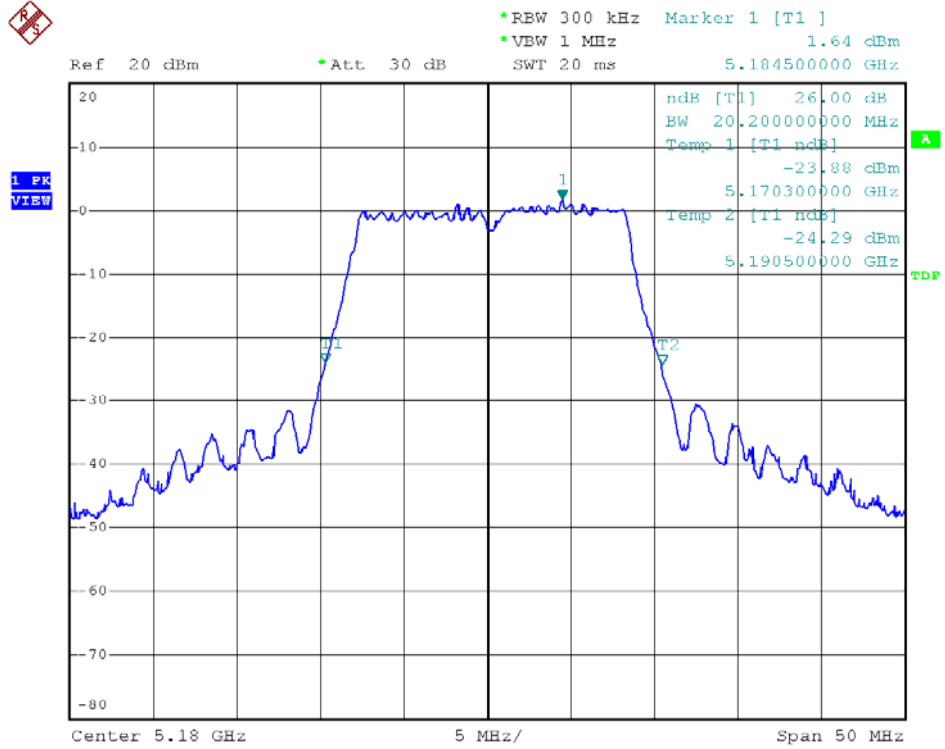

Modulation Standard: 802.11a (6Mbps), Antenna: L
Channel: 44

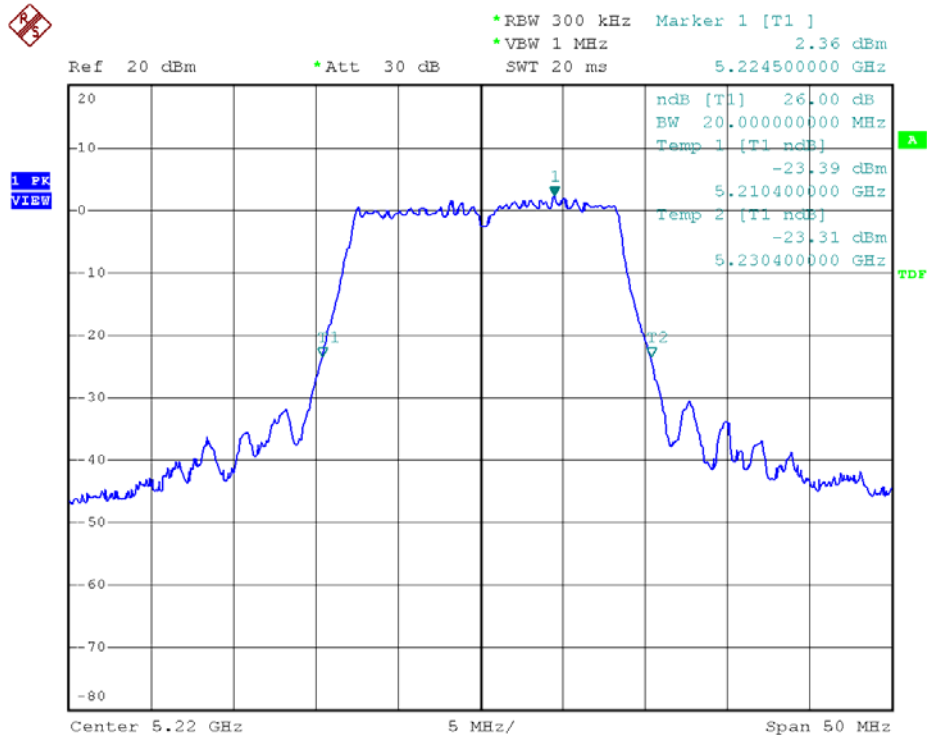



Modulation Standard: 802.11a (6Mbps), Antenna: L
Channel: 48

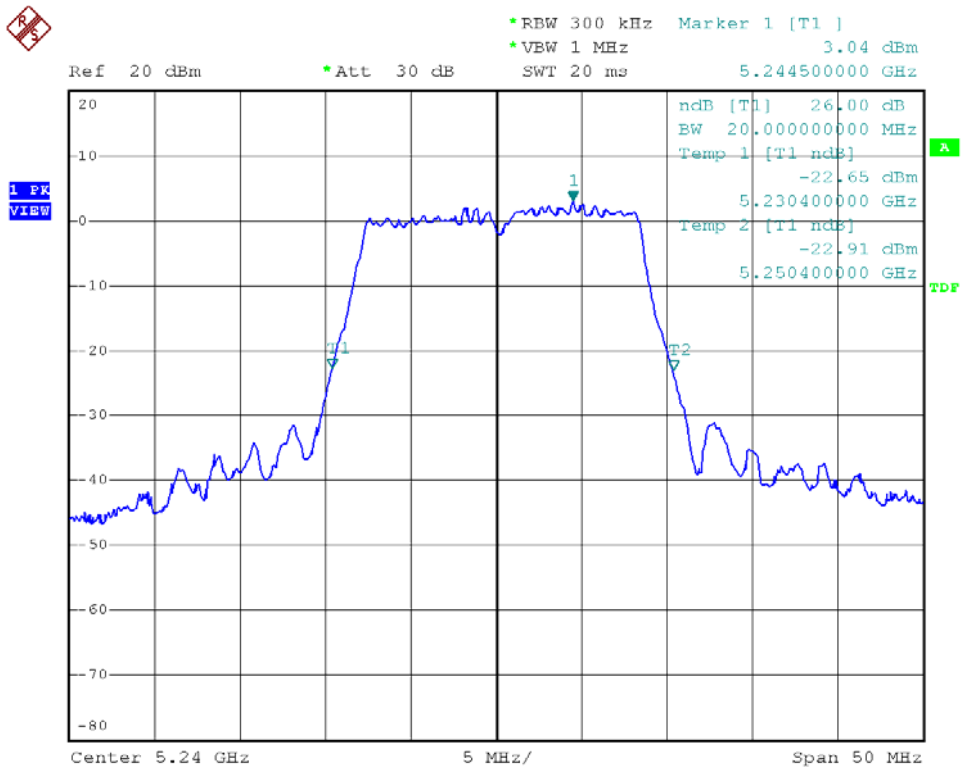

Modulation Standard: 802.11a (6Mbps), Antenna: R
Channel: 36

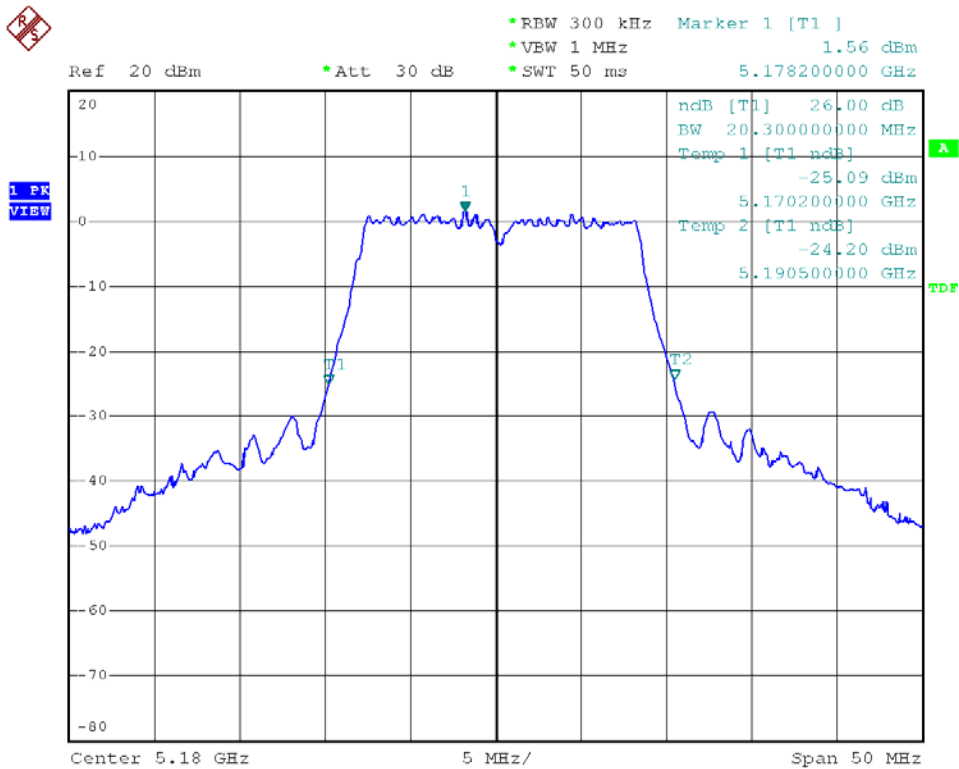



Modulation Standard: 802.11a (6Mbps), Antenna: R
Channel: 44

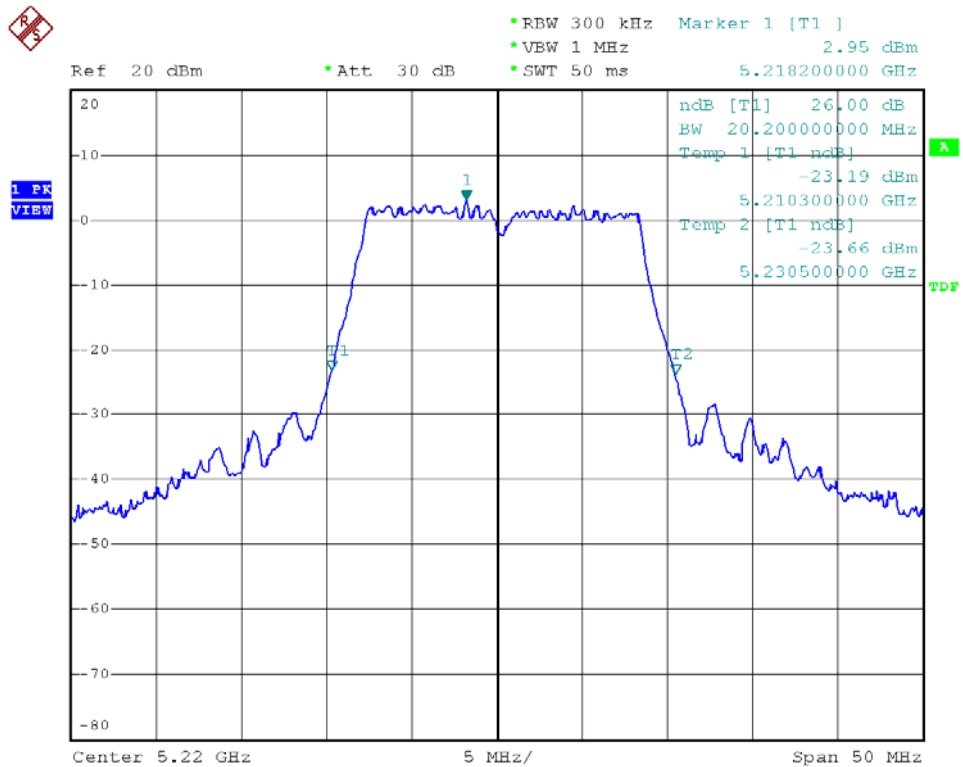

Modulation Standard: 802.11a (6Mbps), Antenna: R
Channel: 48

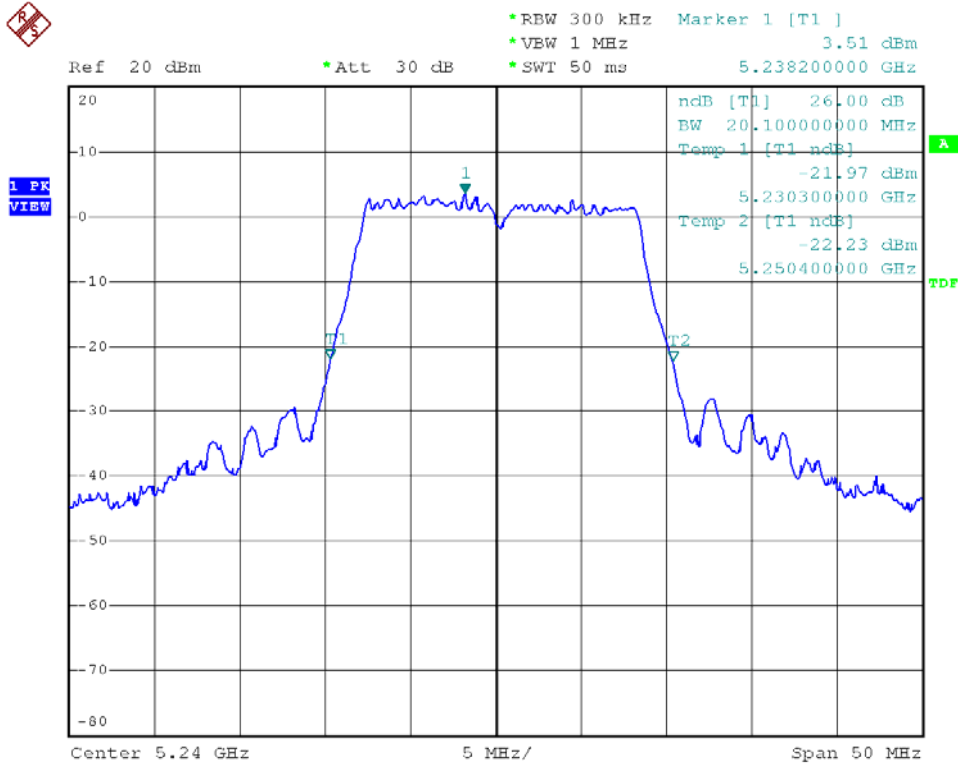



Modulation Standard: 802.11an HT20 (6.5Mbps), Antenna: L
Channel: 36

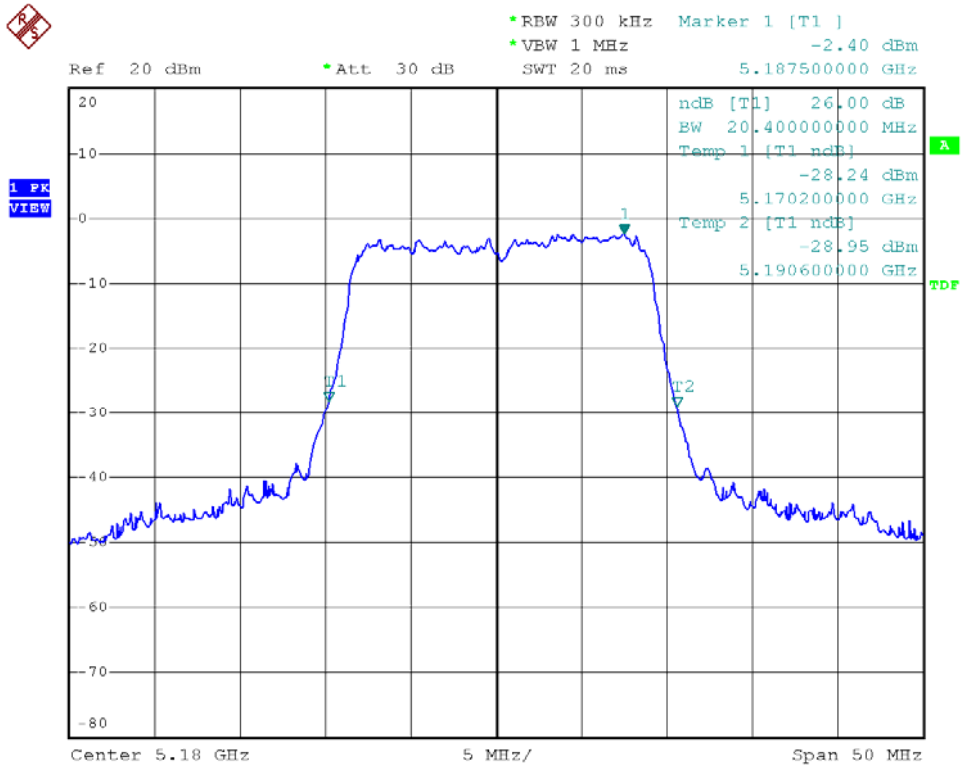

Modulation Standard: 802.11an HT20 (6.5Mbps), Antenna: L
Channel: 44

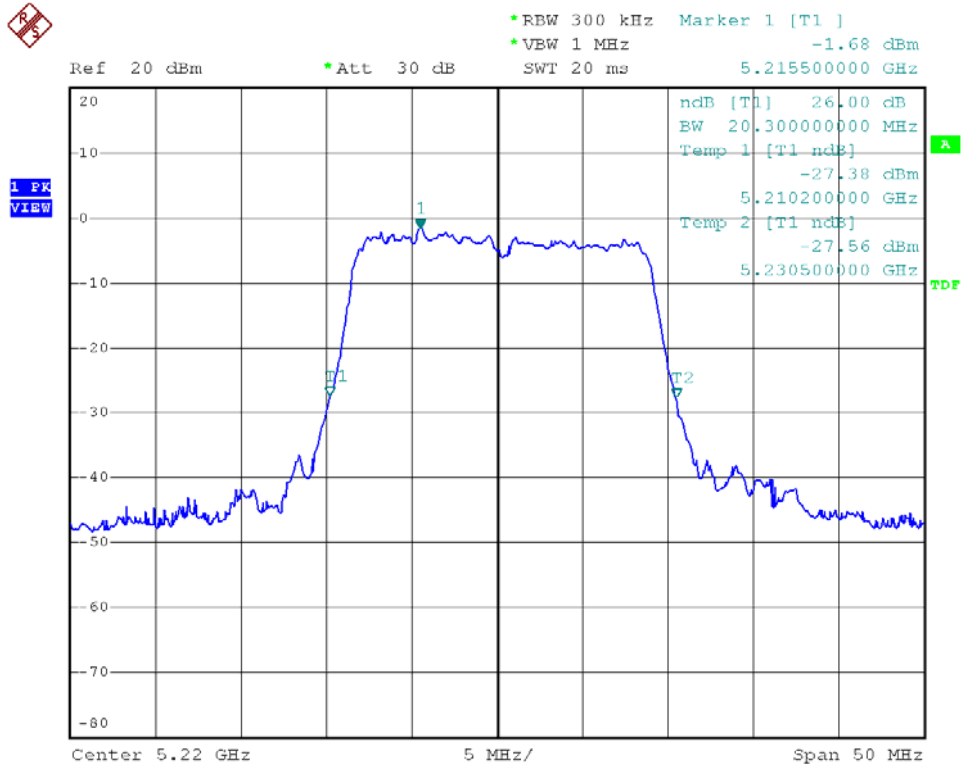



Modulation Standard: 802.11an HT20 (6.5Mbps), Antenna: L
Channel: 48

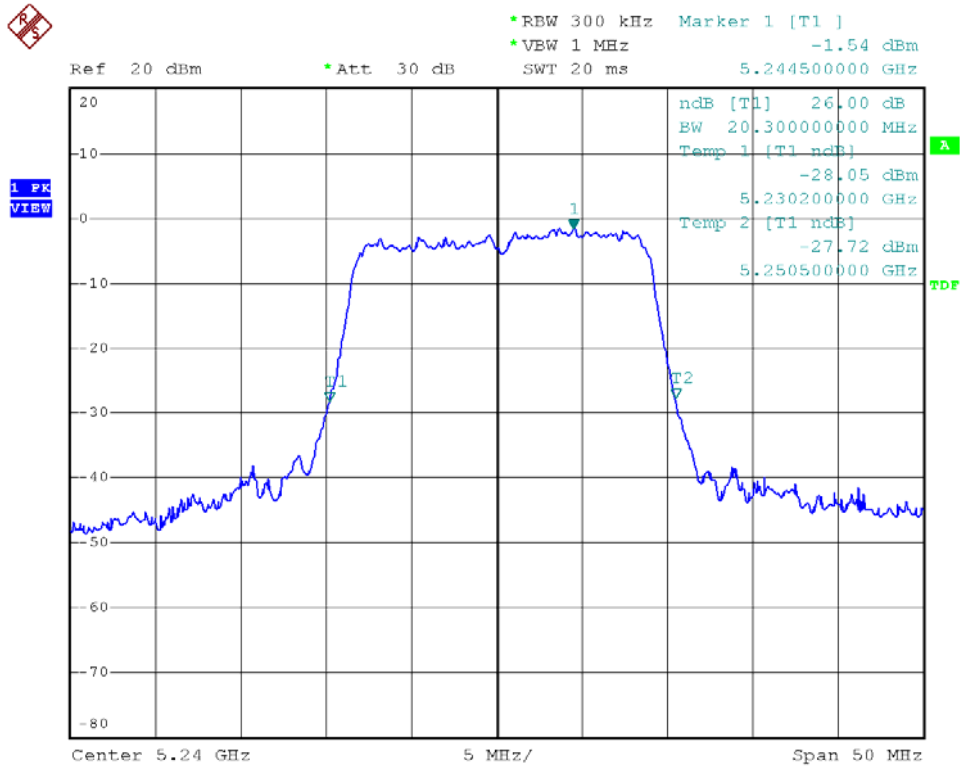

Modulation Standard: 802.11an HT20 (6.5Mbps), Antenna: R
Channel: 36

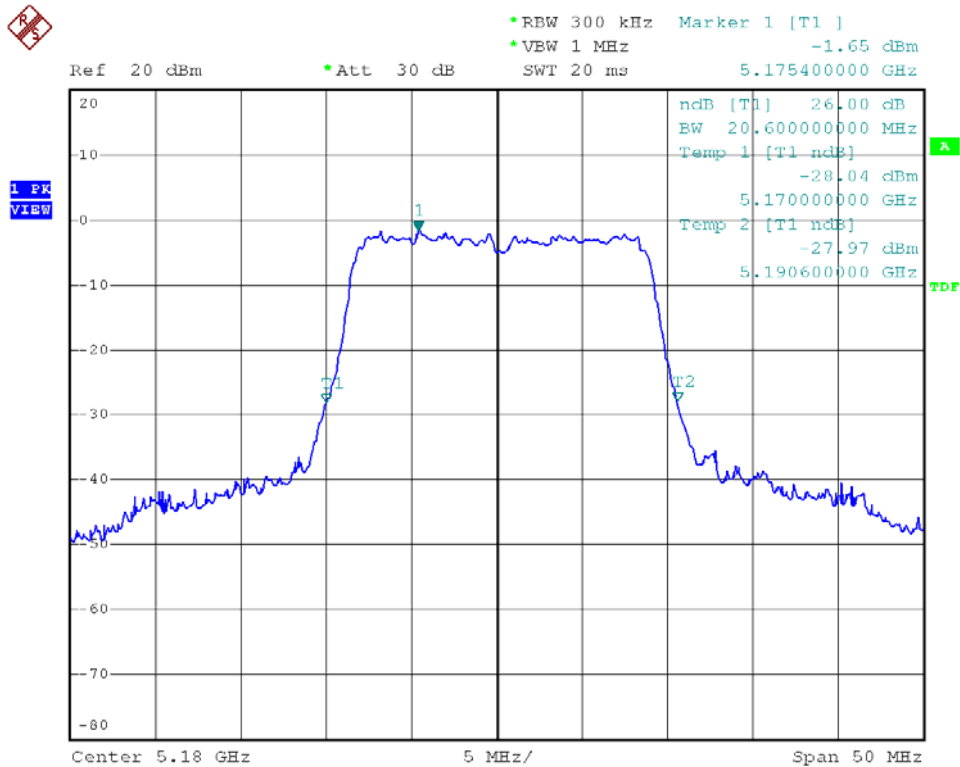



Modulation Standard: 802.11an HT20 (6.5Mbps), Antenna: R
Channel: 44

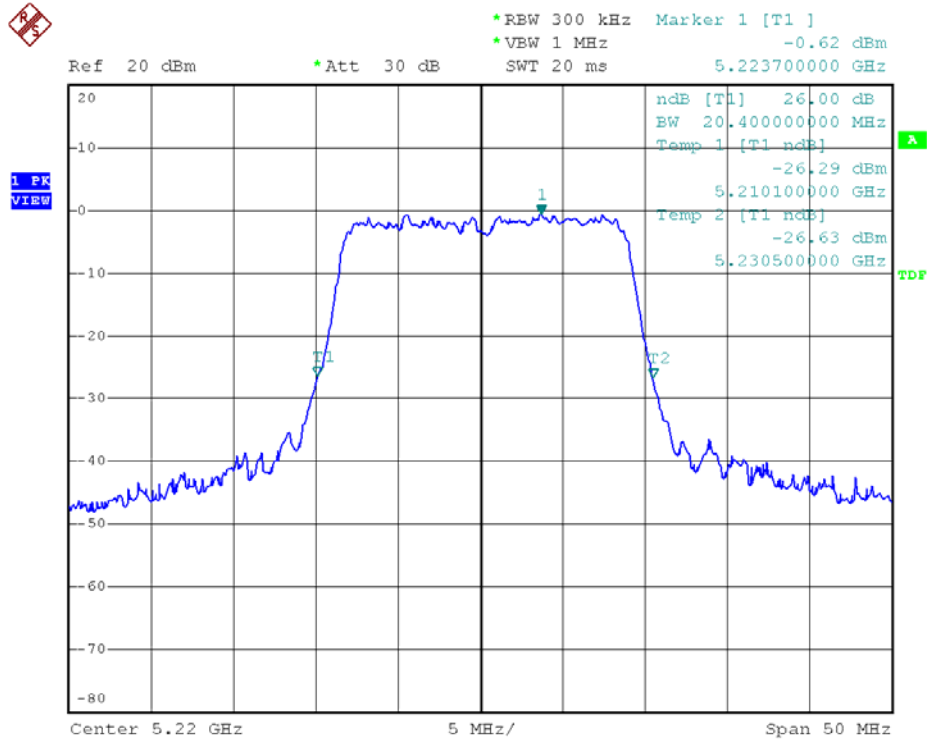

Modulation Standard: 802.11an HT20 (6.5Mbps), Antenna: R
Channel: 48

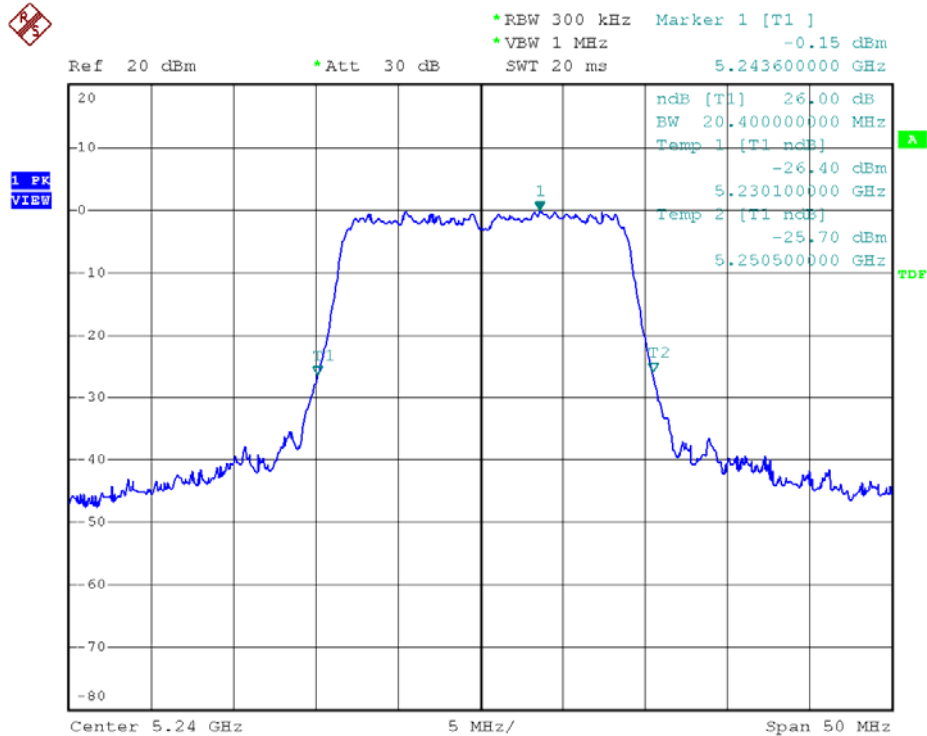



Modulation Standard: 802.11an HT40 (13.5Mbps), Antenna: L
Channel: 38

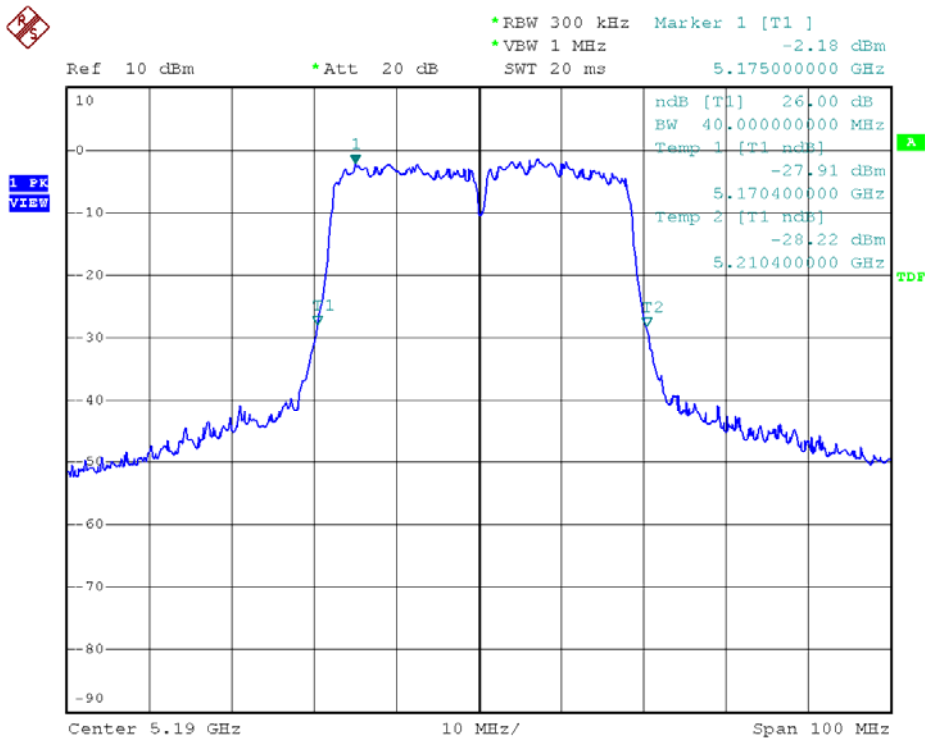

Modulation Standard: 802.11an HT40 (13.5Mbps), Antenna: L
Channel: 46

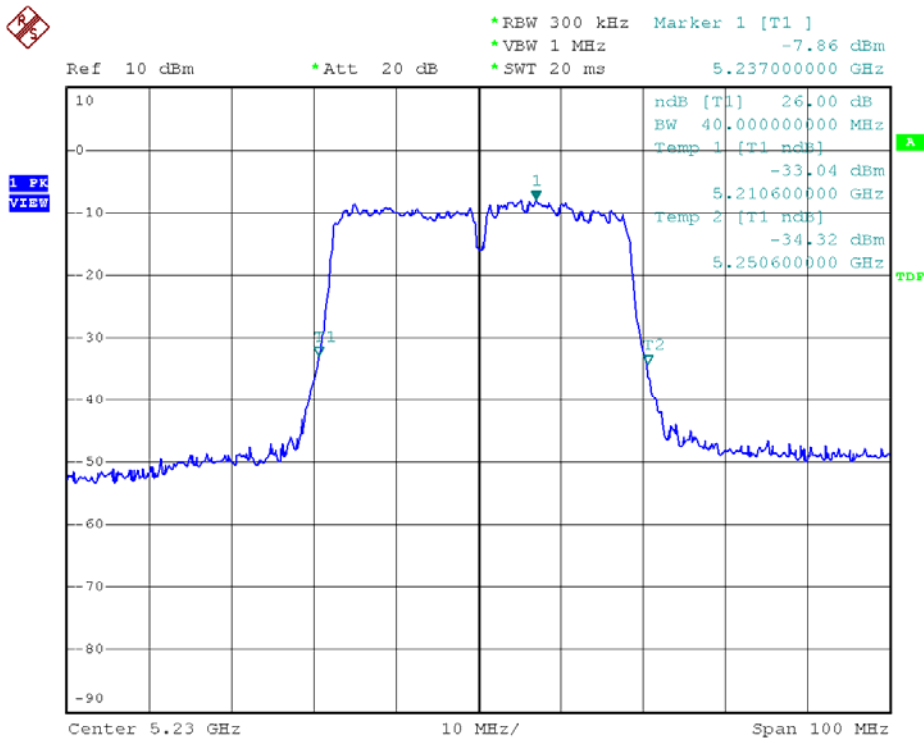



Modulation Standard: 802.11an HT40 (13.5Mbps), Antenna: R
Channel: 38

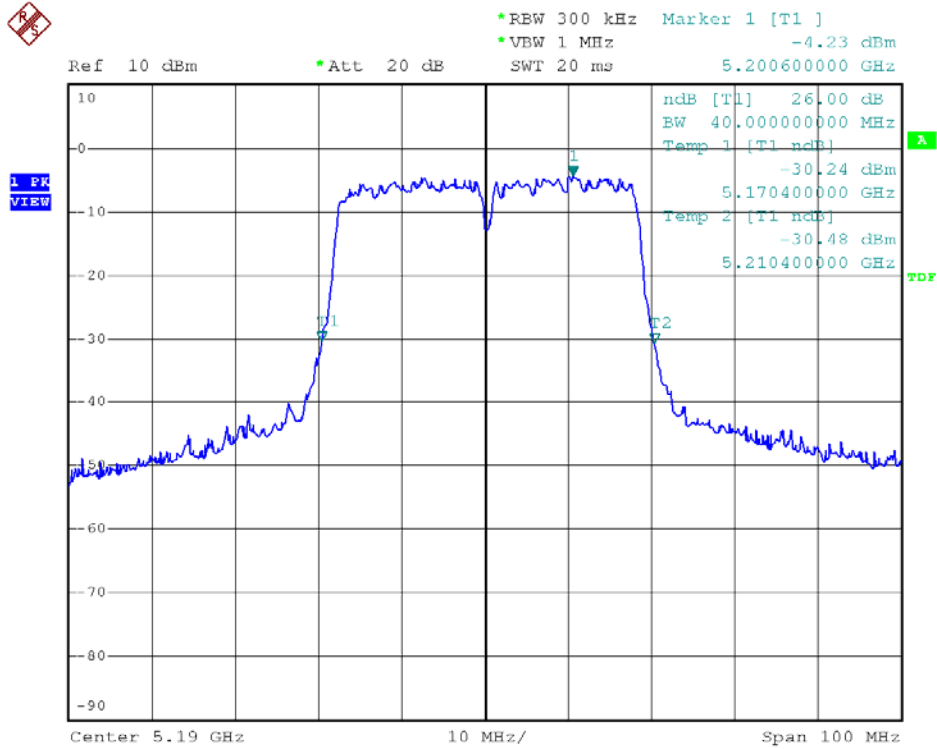

Modulation Standard: 802.11an HT40 (13.5Mbps), Antenna: R
Channel: 46

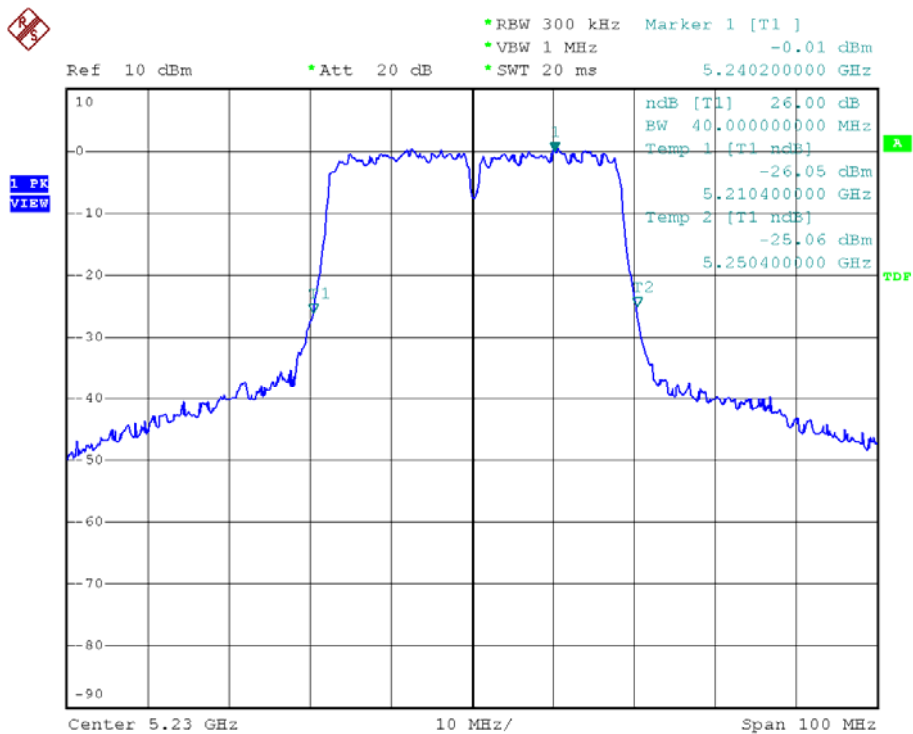



7. Peak Power Excursion

7.1. Test Procedure

1. The transmitter output was connected to the spectrum analyzer
2. Using Peak detector and max-hold function for Trace 1 MHz and VBW to 3 MHz for Trace 1.
Using average detector for Trace 2.
3. Set RBW of spectrum analyzer to 1 MHz and VBW to 3 MHz for Trace 1.
Set RBW of spectrum analyzer to 1 MHz and VBW to 300 kHz for Trace 2.
4. The largest difference between Trace 1 and Trace 2 in any 1 MHz band on any frequency was recorded.

7.2. Test Setup Layout

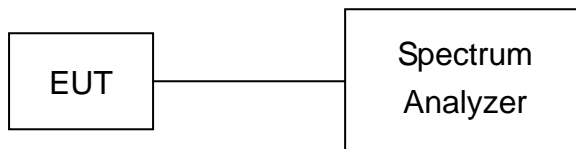

7.3. Measurement Equipment

Instrument/Ancillary	Model No.	Manufacturer	Serial No.	Calibration Date	Valid Date.
Spectrum Analyzer	FSP40	R&S	10047	2008/02/22	2009/02/21

7.4. Test Result and Data

Test Date: Nov. 08, 2008

Temperature: 20

Atmospheric pressure: 1008 hPa

Humidity: 60%

Modulation Standard	Channel	Frequency (MHz)	Peak Power Output (dBm)		Limit (dB)
			L	R	
802.11a (6Mbps)	36	5180	10.80	10.59	13
	44	5220	10.68	10.80	13
	48	5240	10.75	10.92	13
802.11an HT20 (6.5Mbps)	36	5180	11.15	10.49	13
	44	5220	11.26	10.62	13
	48	5240	11.23	10.57	13
802.11an HT40 (13.5Mbps)	38	5190	6.68	6.62	13
	46	5230	7.51	6.85	13



Modulation Standard: 802.11a (6Mbps), Antenna: L
Channel: 36

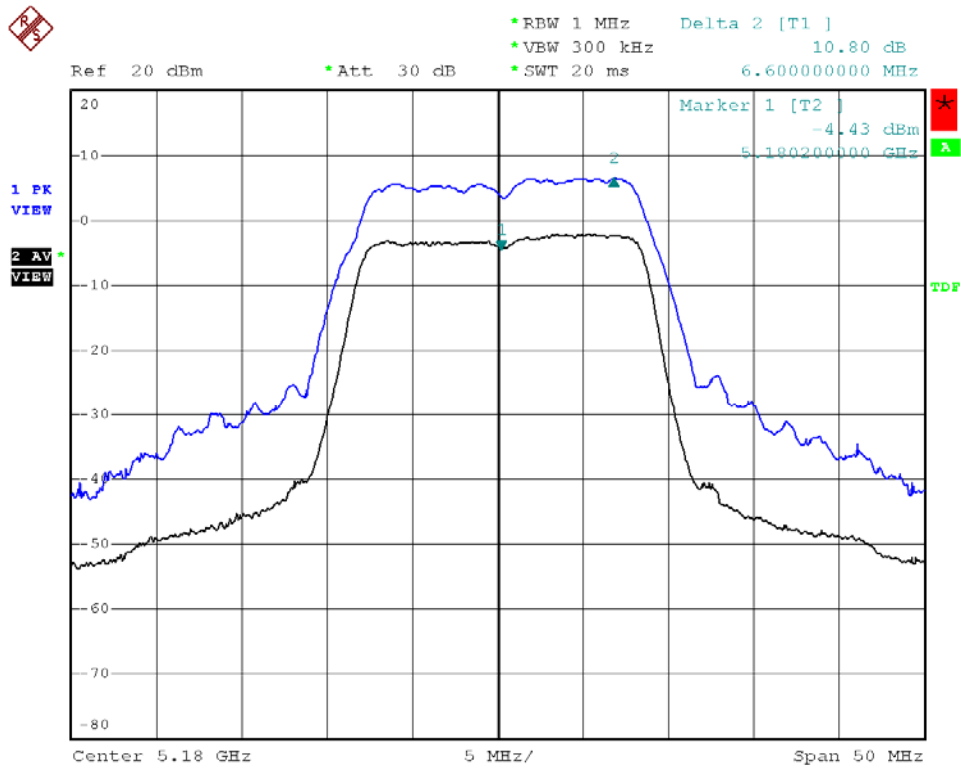

Modulation Standard: 802.11a (6Mbps), Antenna: L
Channel: 44

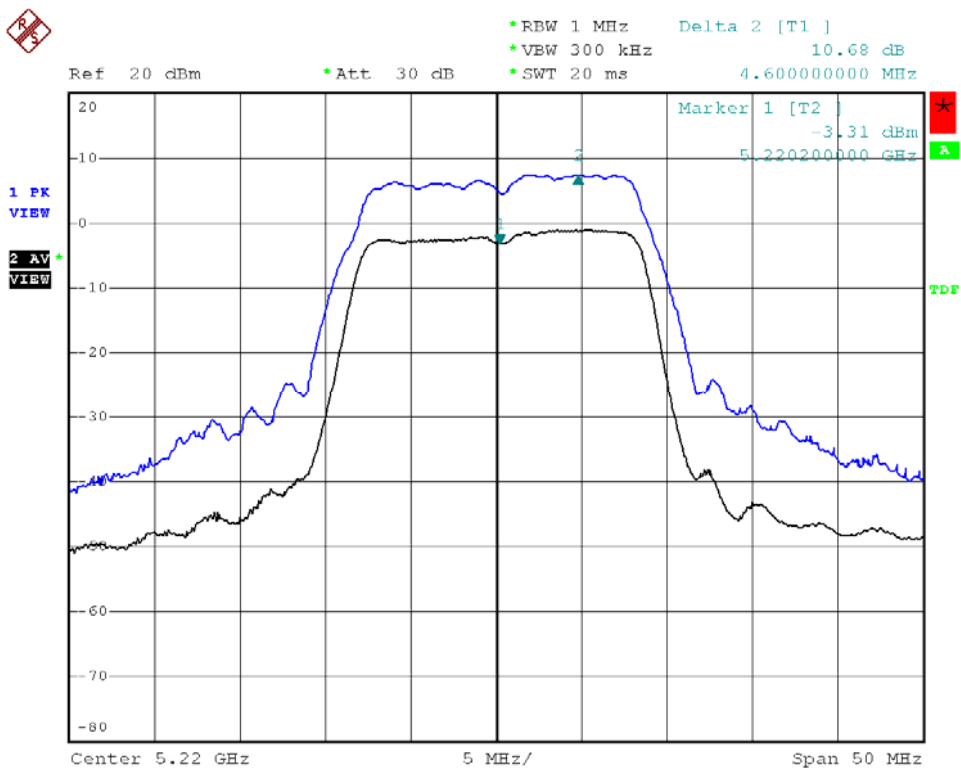



Modulation Standard: 802.11a (6Mbps), Antenna: L
Channel: 48

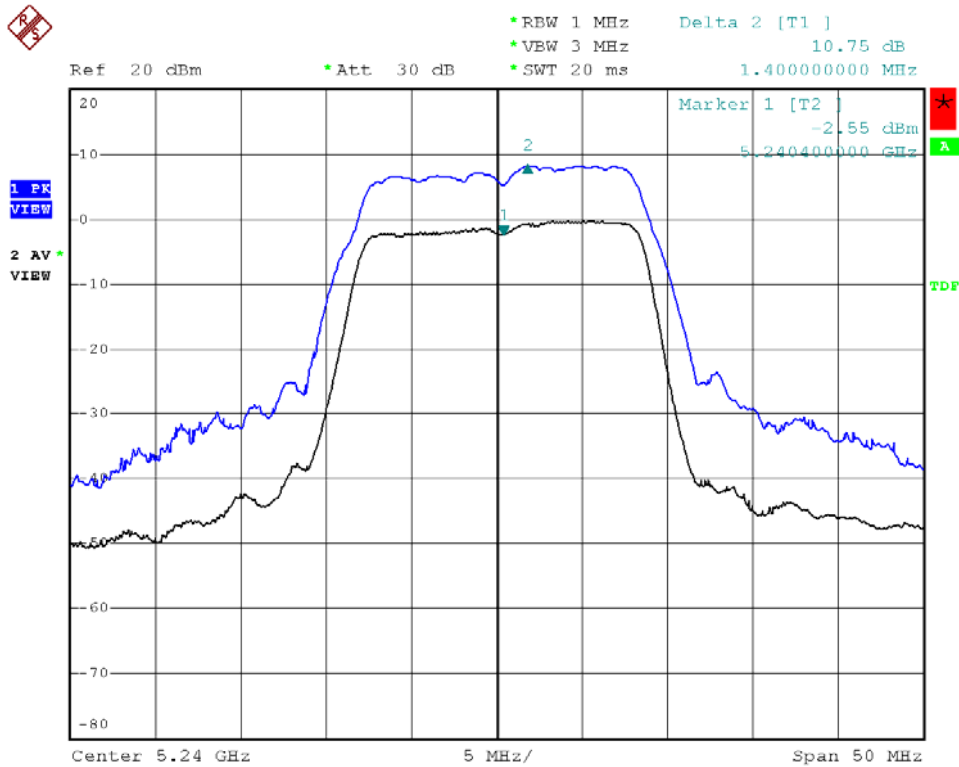

Modulation Standard: 802.11a (6Mbps), Antenna: R
Channel: 36

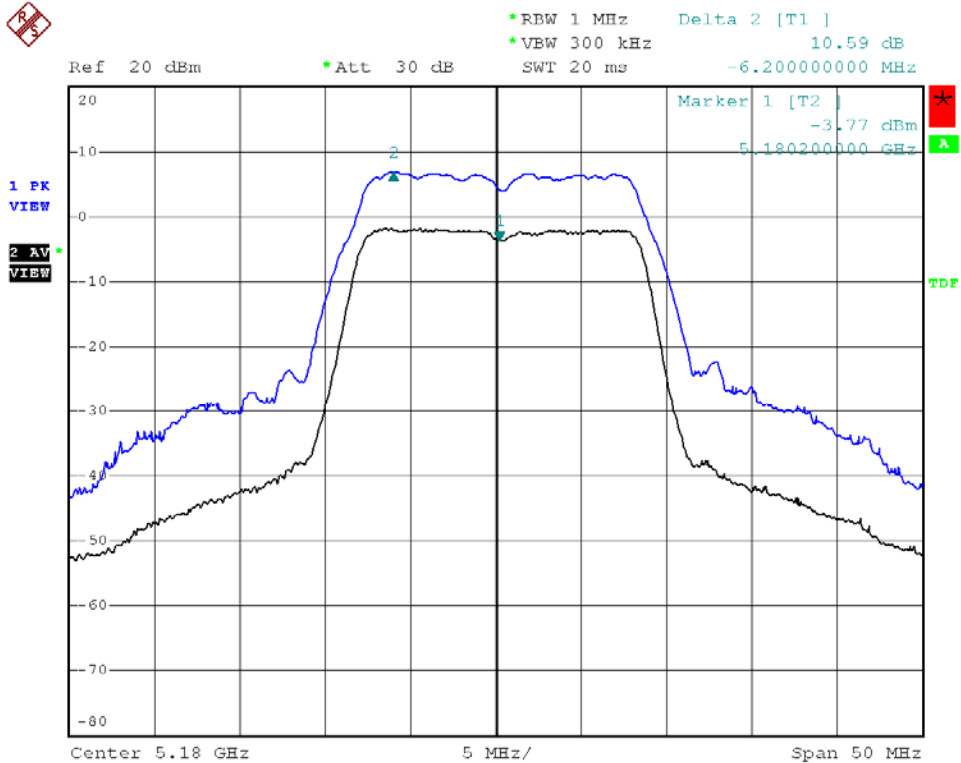



Modulation Standard: 802.11a (6Mbps), Antenna: R
Channel: 44

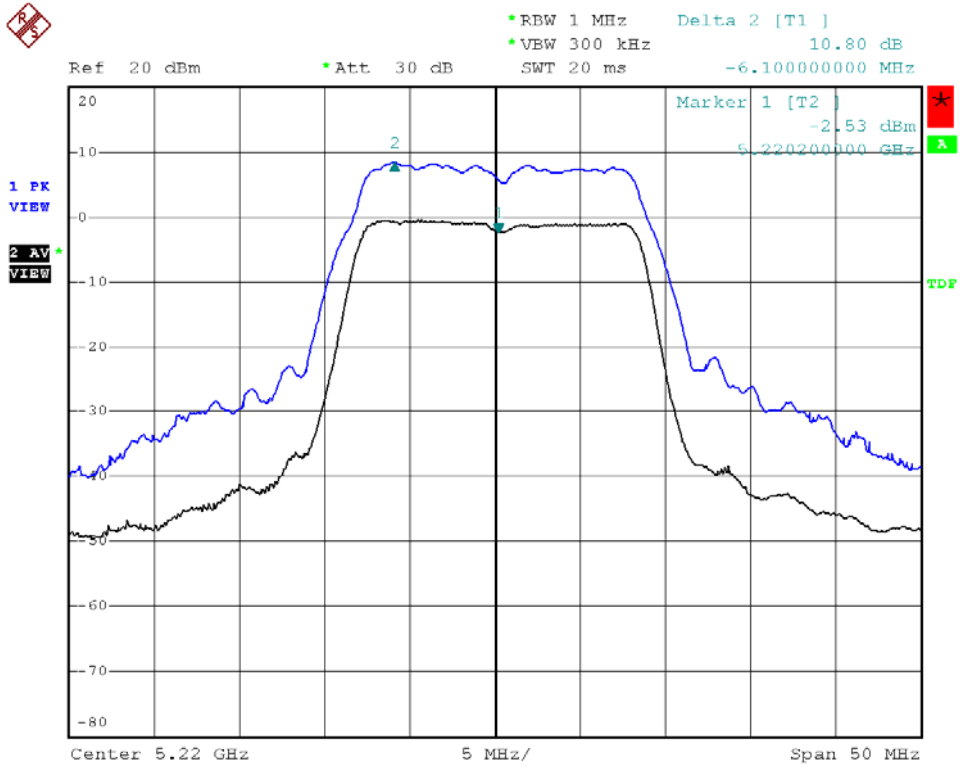

Modulation Standard: 802.11a (6Mbps), Antenna: R
Channel: 48

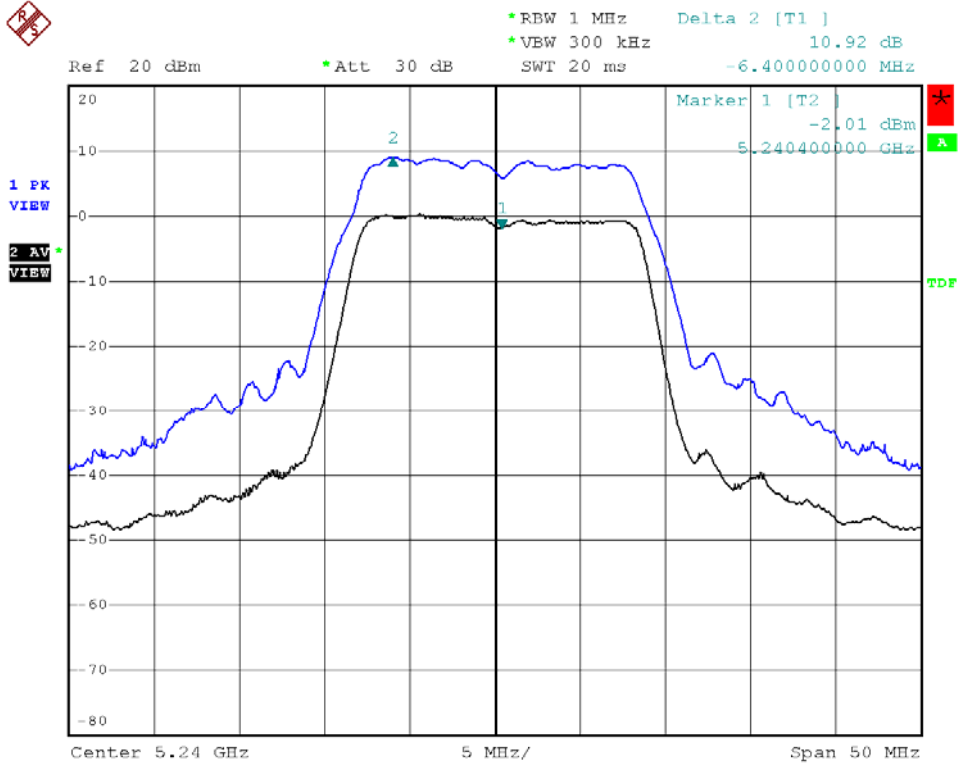



Modulation Standard: 802.11an HT20 (6.5Mbps), Antenna: L
Channel: 36

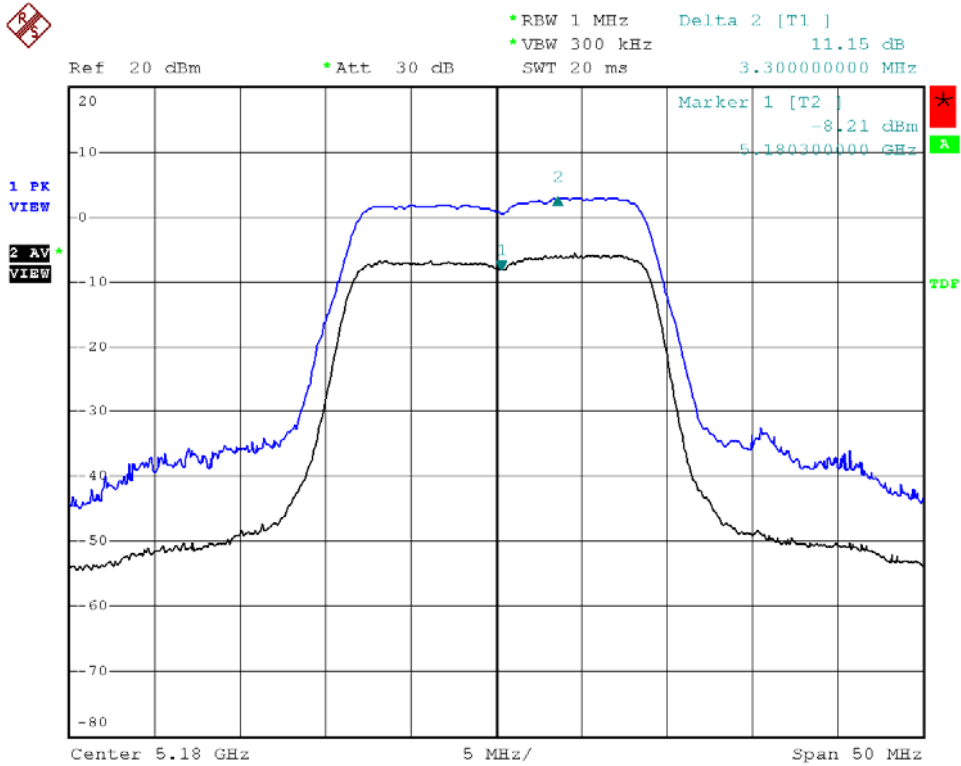

Modulation Standard: 802.11an HT20 (6.5Mbps), Antenna: L
Channel: 44

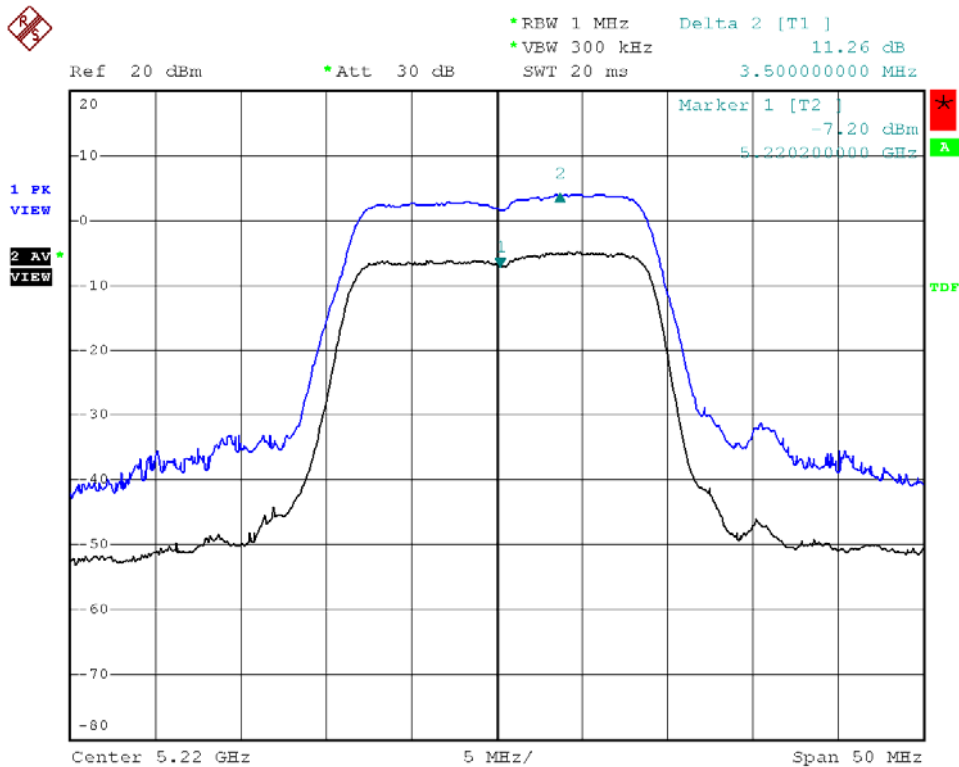



Modulation Standard: 802.11an HT20 (6.5Mbps), Antenna: L
Channel: 48

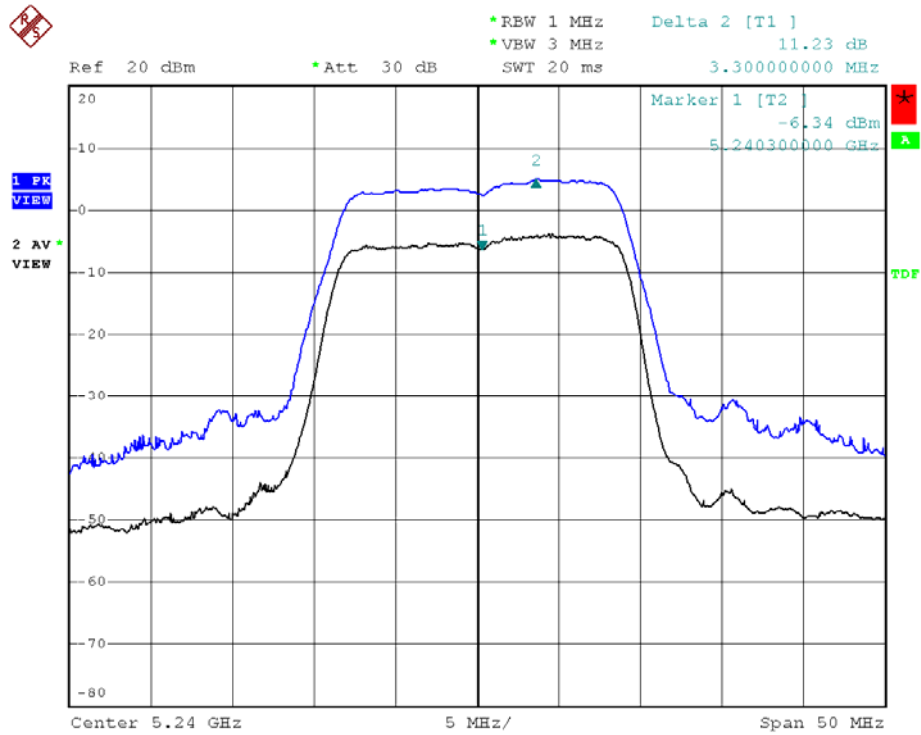

Modulation Standard: 802.11an HT20 (6.5Mbps), Antenna: R
Channel: 36

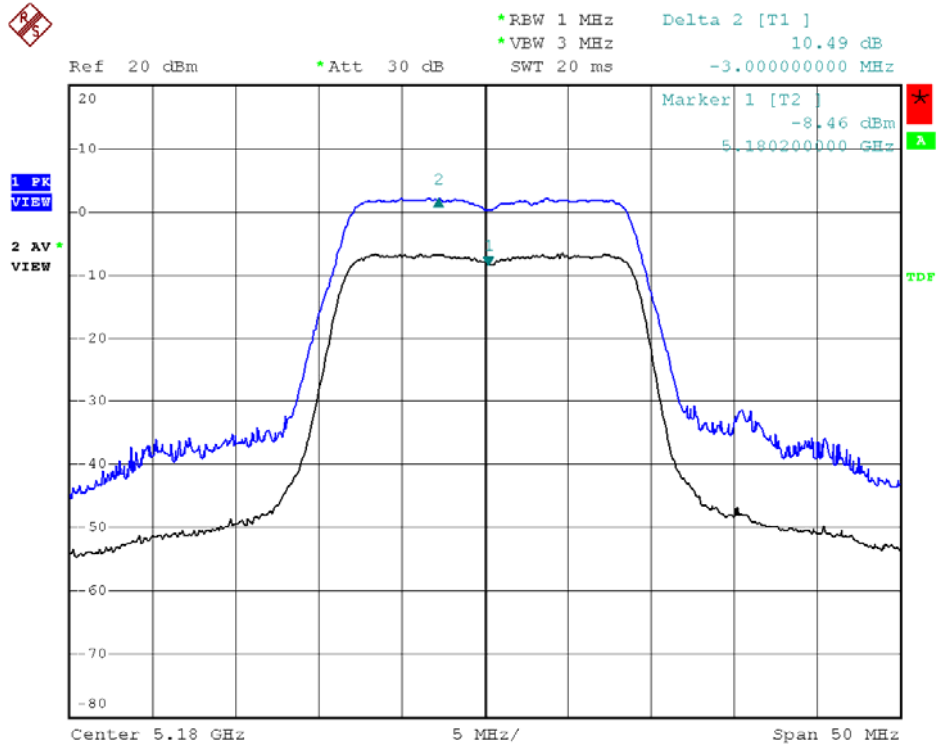



Modulation Standard: 802.11an HT20 (6.5Mbps), Antenna: R
Channel: 44

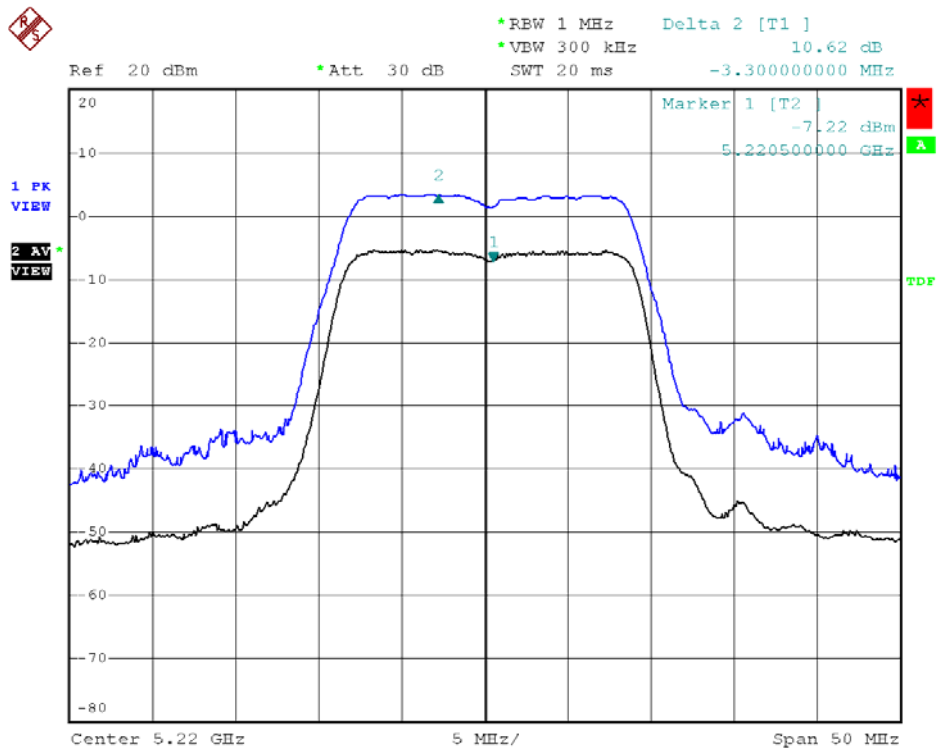

Modulation Standard: 802.11an HT20 (6.5Mbps), Antenna: R
Channel: 48

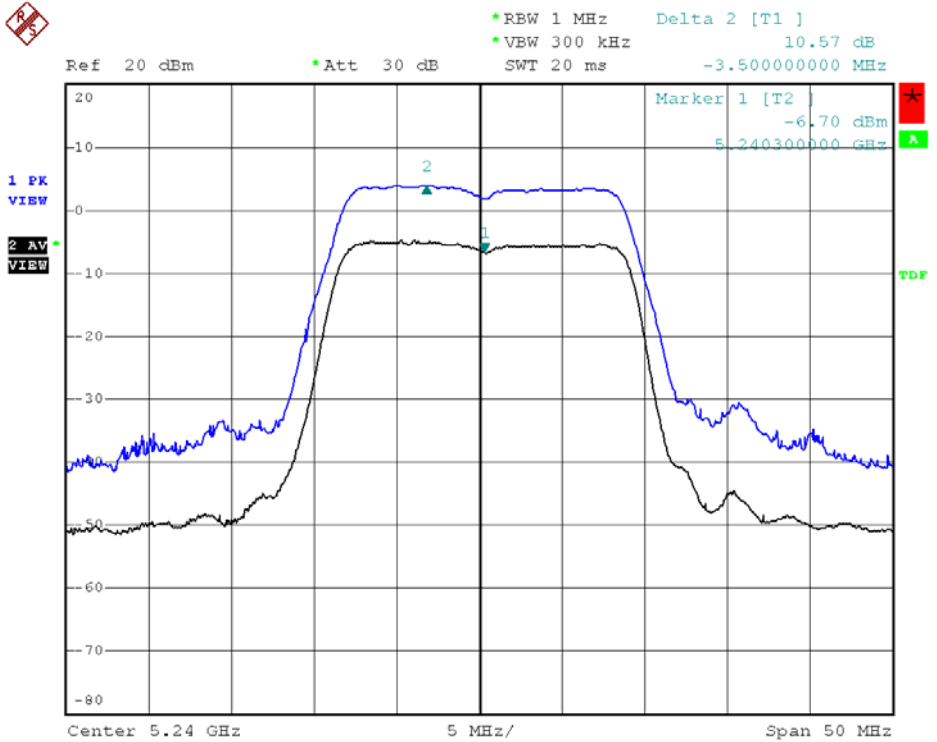



Modulation Standard: 802.11an HT40 (13.5Mbps), Antenna: L
Channel: 38

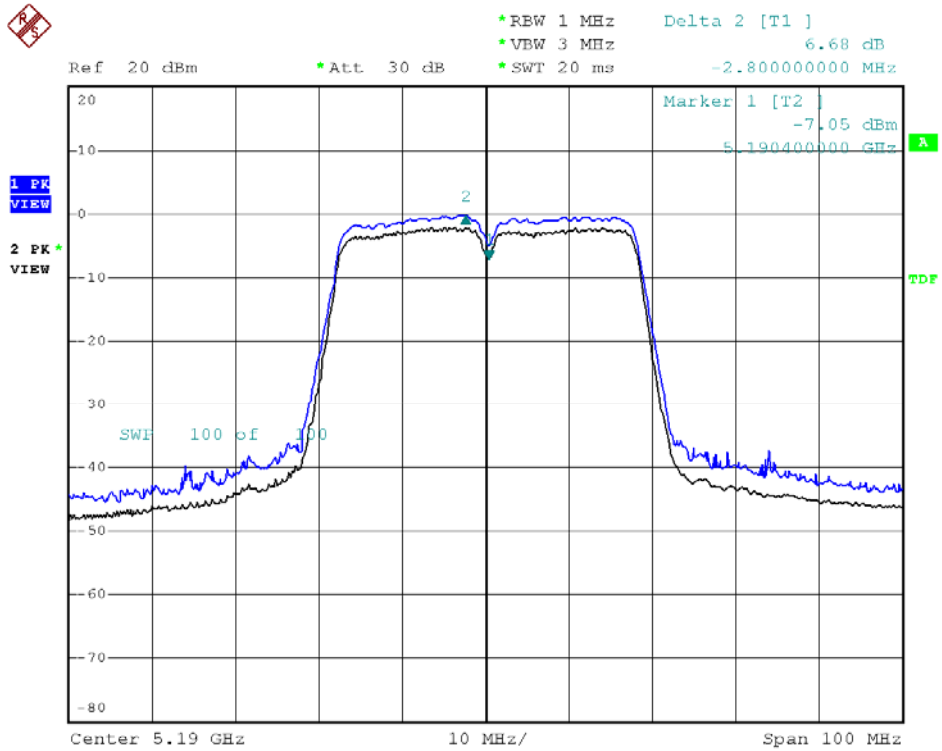

Modulation Standard: 802.11an HT40 (13.5Mbps), Antenna: L
Channel: 46

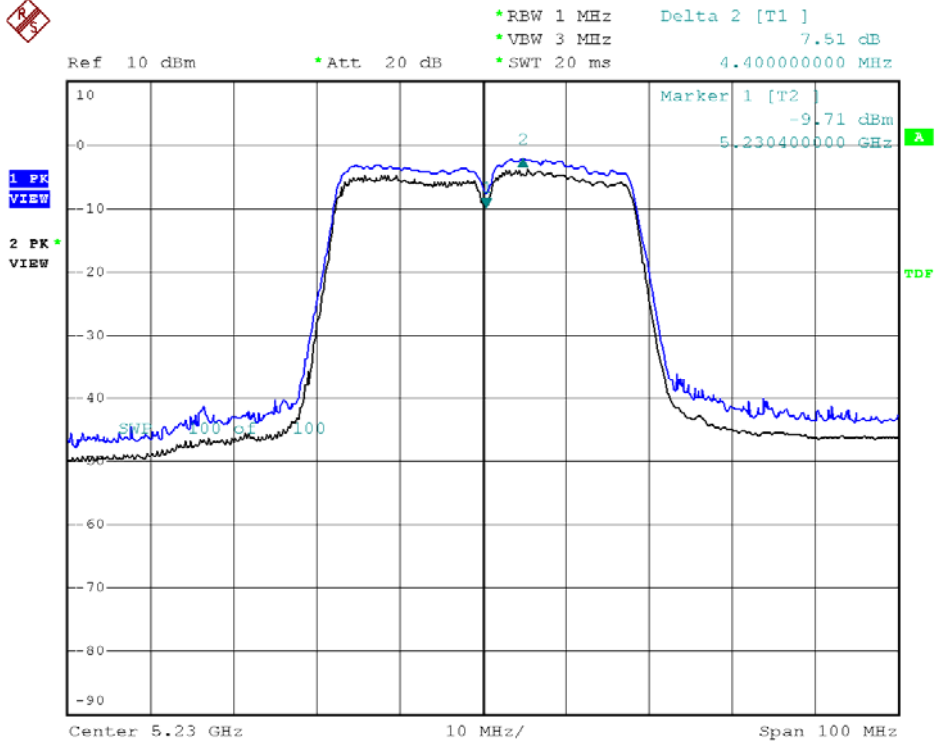



Modulation Standard: 802.11an HT40 (13.5Mbps), Antenna: R
Channel: 38

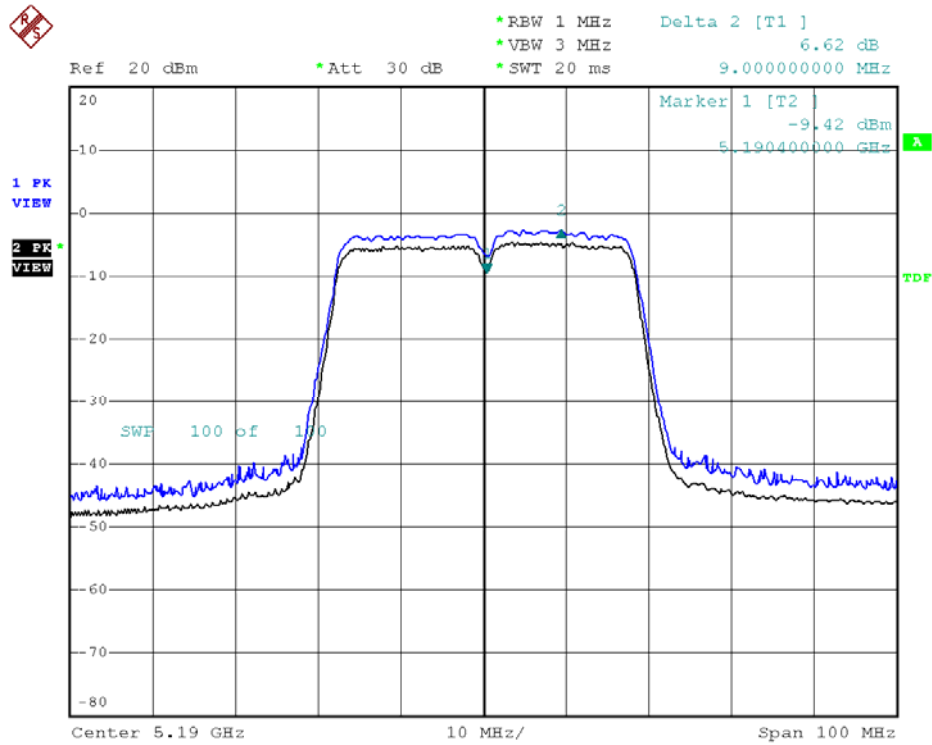

Modulation Standard: 802.11an HT40 (13.5Mbps), Antenna: R
Channel: 46

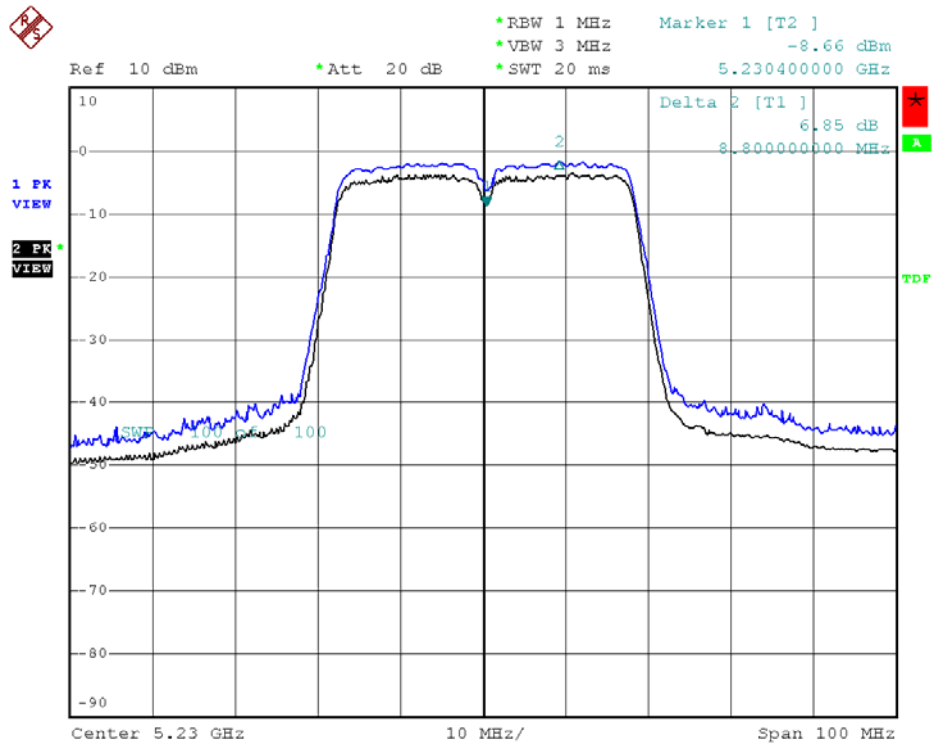



8. Peak Power Spectral Density

8.1. Test Procedure

1. The transmitter output was connected to spectrum analyzer.
2. Set RBW of spectrum analyzer to 1 MHz and VBW to 3 MHz
3. The Peak Power Spectral Density is the highest level found across the emission in any 1MHz Band

8.2. Test Setup Layout

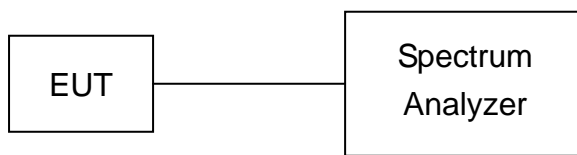

8.3. Measurement Equipment

Instrument/Ancillary	Model No.	Manufacturer	Serial No.	Calibration Date	Valid Date.
Spectrum Analyzer	FSP40	R&S	10047	2008/02/22	2009/02/21

8.4. Test Result and Data

Test Date: Nov. 08, 2008

Temperature: 20

Atmospheric pressure: 1008 hPa

Humidity: 60%

Modulation Standard	Channel	Frequency (MHz)	RF Power Level In 1MHz BW (dBm)		Limit (dB)
			L	R	
802.11a (6Mbps)	36	5180	-3.41	-2.94	4
	44	5220	-2.02	-1.54	4
	48	5240	-1.33	-1.23	4

Modulation Standard	Channel	Frequency (MHz)	RF Power Level In 1MHz BW (dBm)			Limit (dB)
			L	R	L + R	
802.11an HT20 (6.5Mbps)	36	5180	-7.70	-4.81	-3.01	4
	44	5220	-5.45	-3.54	-1.38	4
	48	5240	-5.42	-3.21	-1.17	4
802.11an HT40 (13.5Mbps)	38	5190	-10.30	-12.41	-8.22	4
	46	5230	-12.44	-11.64	-9.01	4



Modulation Standard: 802.11a (6Mbps), Antenna: L
Channel: 36

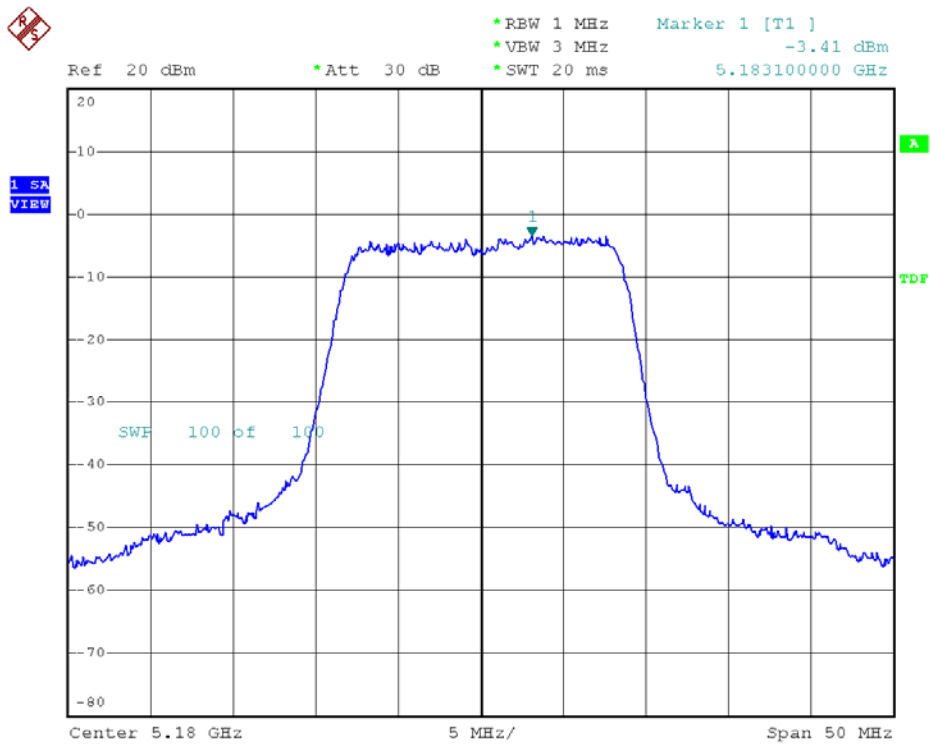

Modulation Standard: 802.11a (6Mbps), Antenna: L
Channel: 44

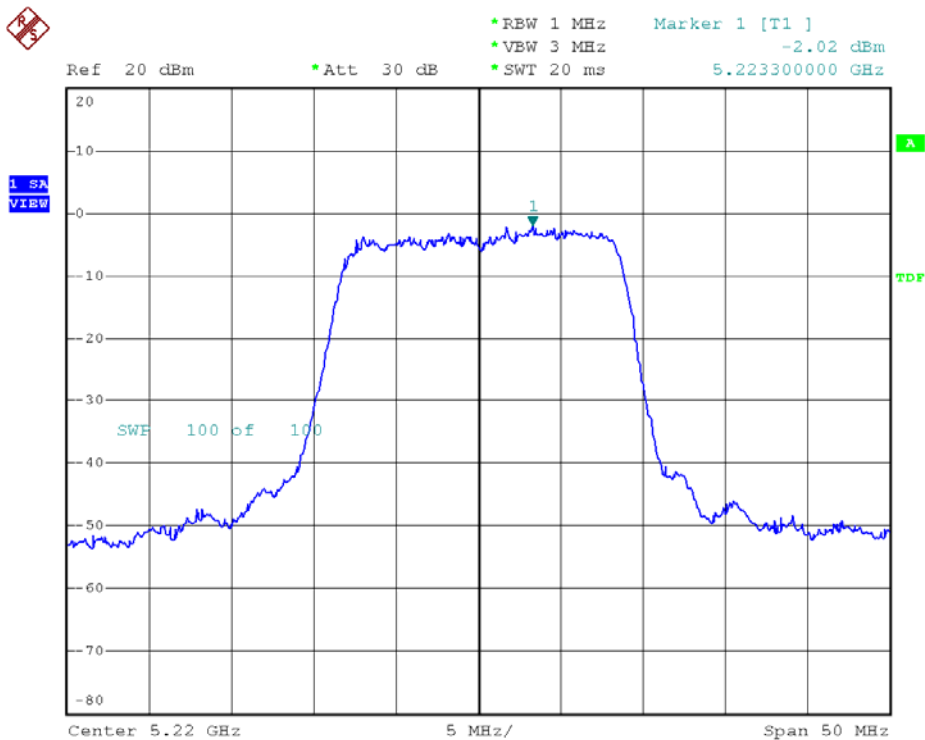



Modulation Standard: 802.11a (6Mbps), Antenna: L
Channel: 48

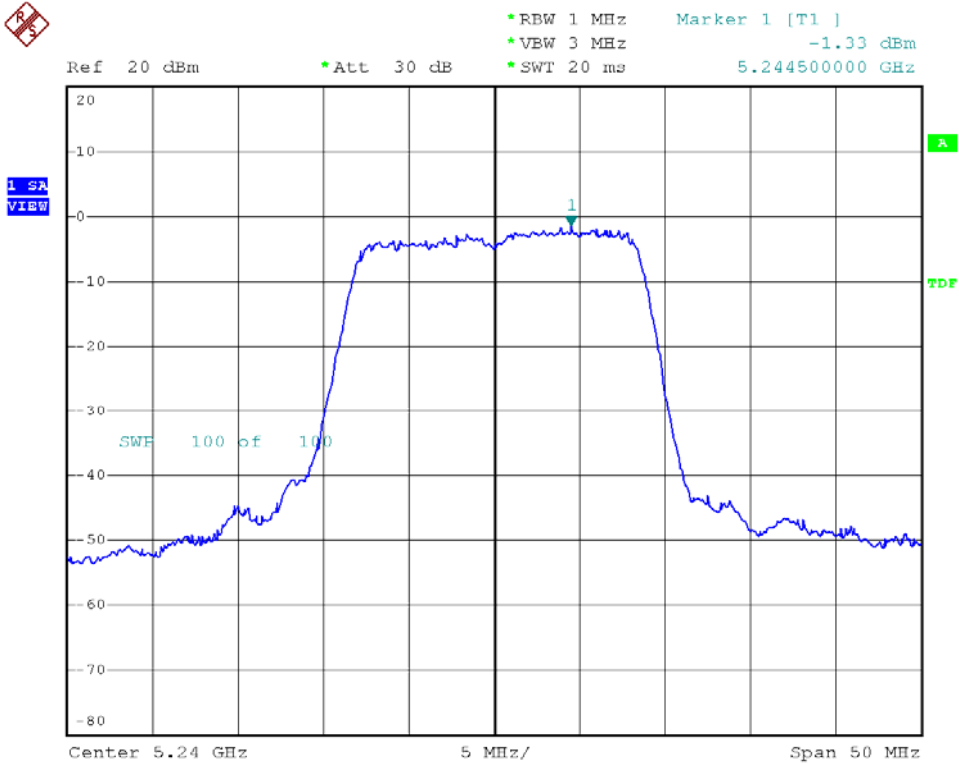

Modulation Standard: 802.11a (6Mbps), Antenna: R
Channel: 36

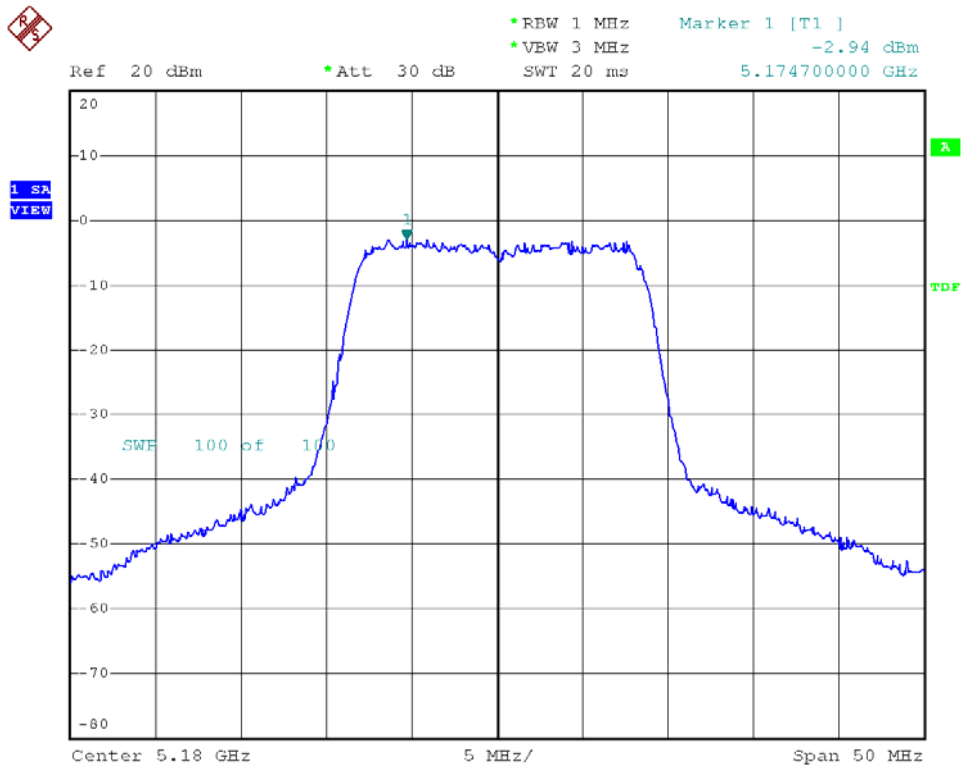



Modulation Standard: 802.11a (6Mbps), Antenna: R
Channel: 44

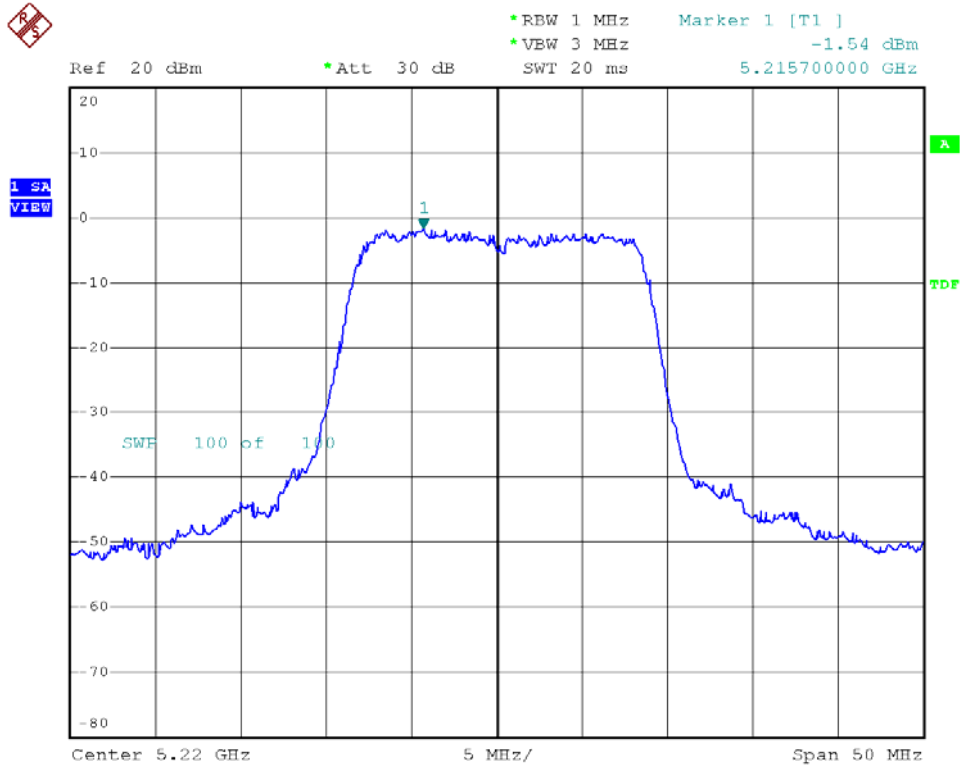

Modulation Standard: 802.11a (6Mbps), Antenna: R
Channel: 48

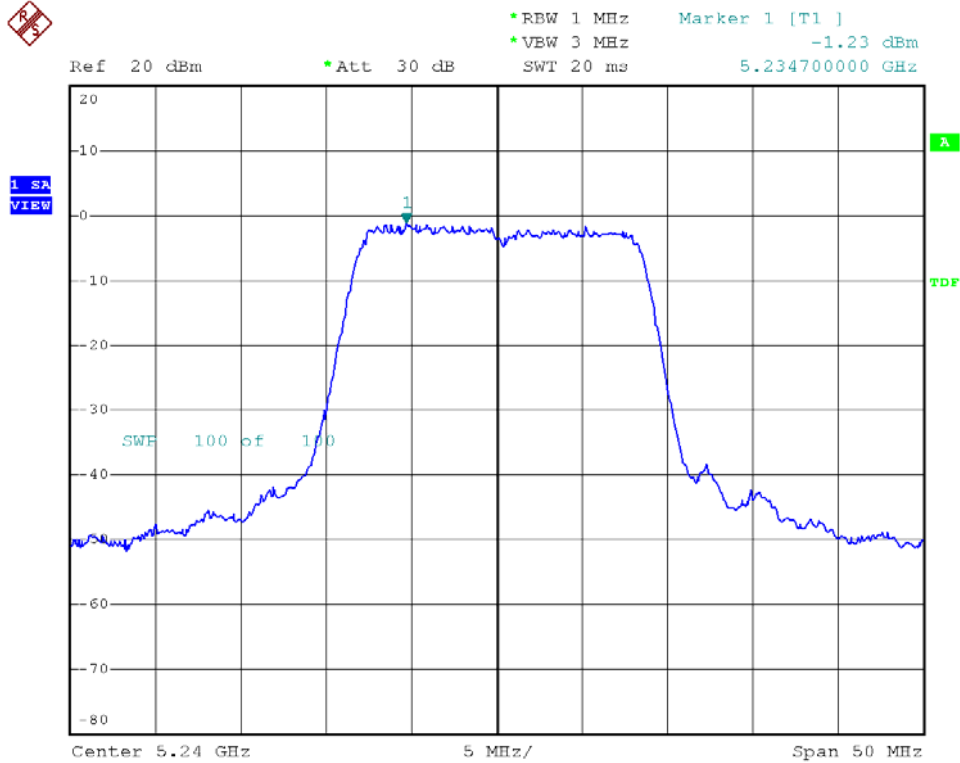



Modulation Standard: 802.11an HT20 (6.5Mbps), Antenna: L
Channel: 36

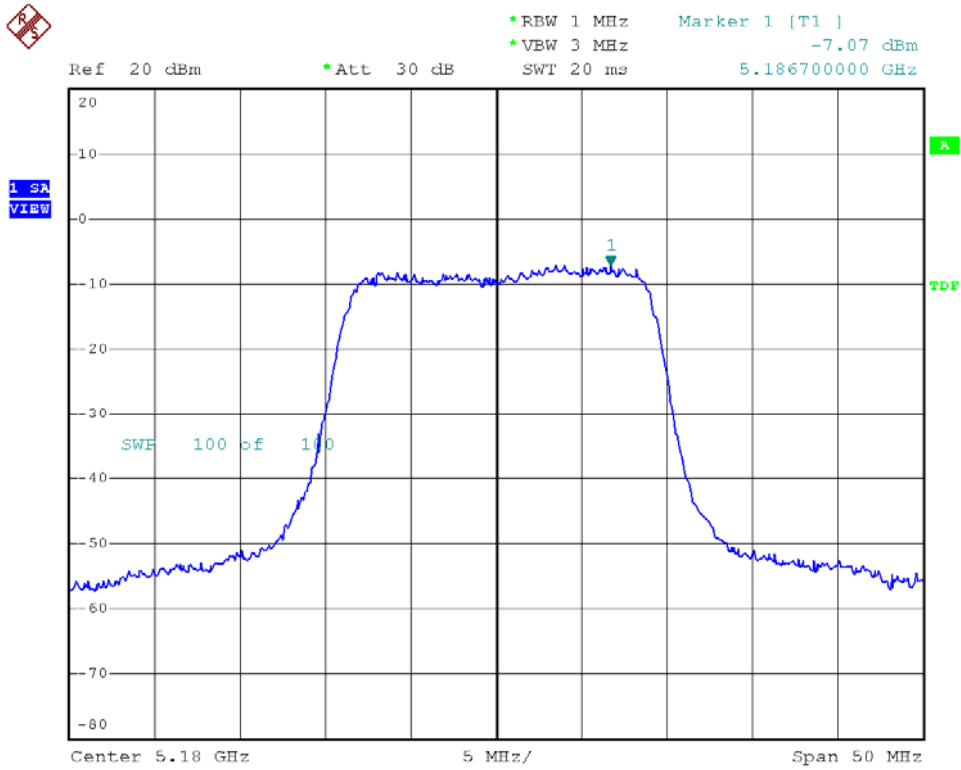

Modulation Standard: 802.11an HT20 (6.5Mbps), Antenna: L
Channel: 44

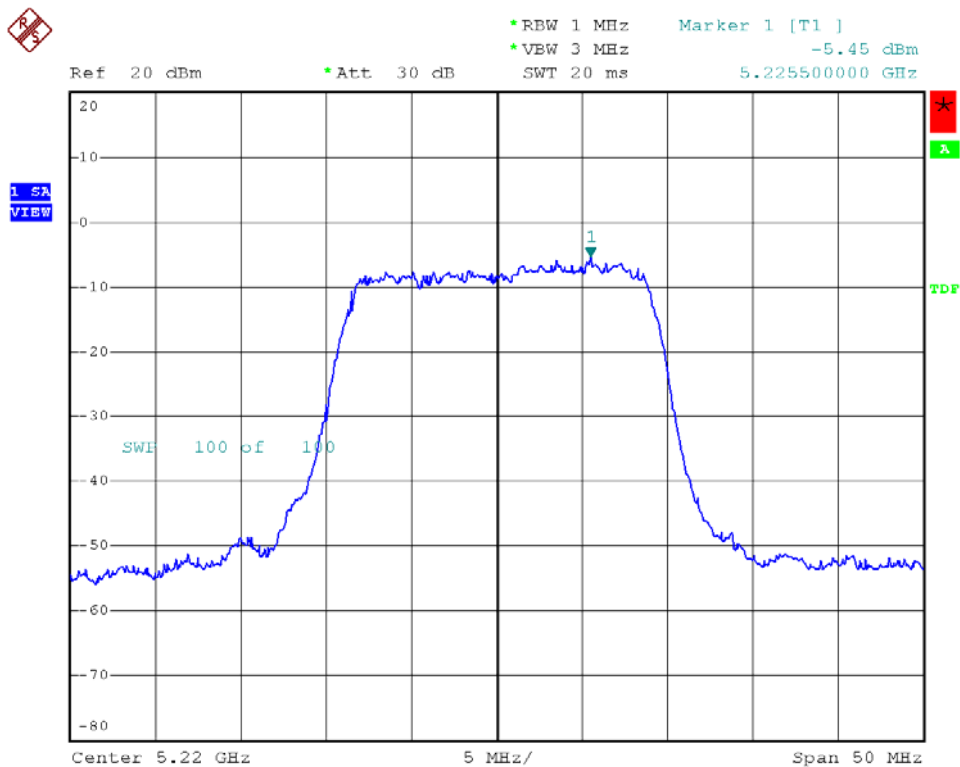



Modulation Standard: 802.11an HT20 (6.5Mbps), Antenna: L
Channel: 48

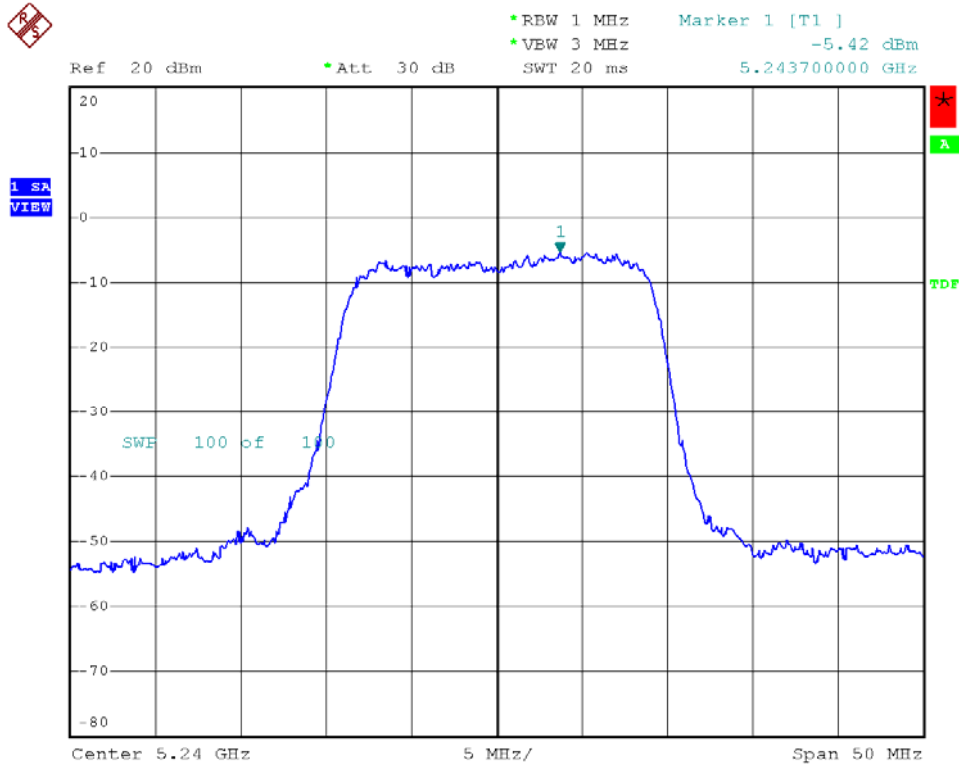

Modulation Standard: 802.11an HT20 (6.5Mbps), Antenna: R
Channel: 36

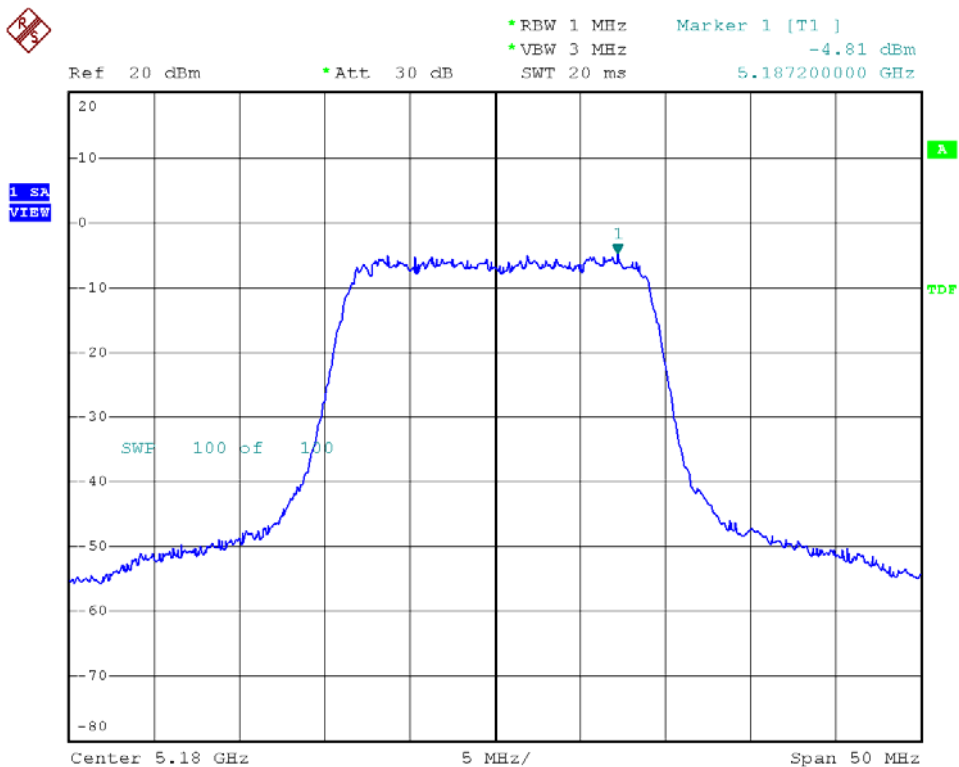



Modulation Standard: 802.11an HT20 (6.5Mbps), Antenna: R
Channel: 44

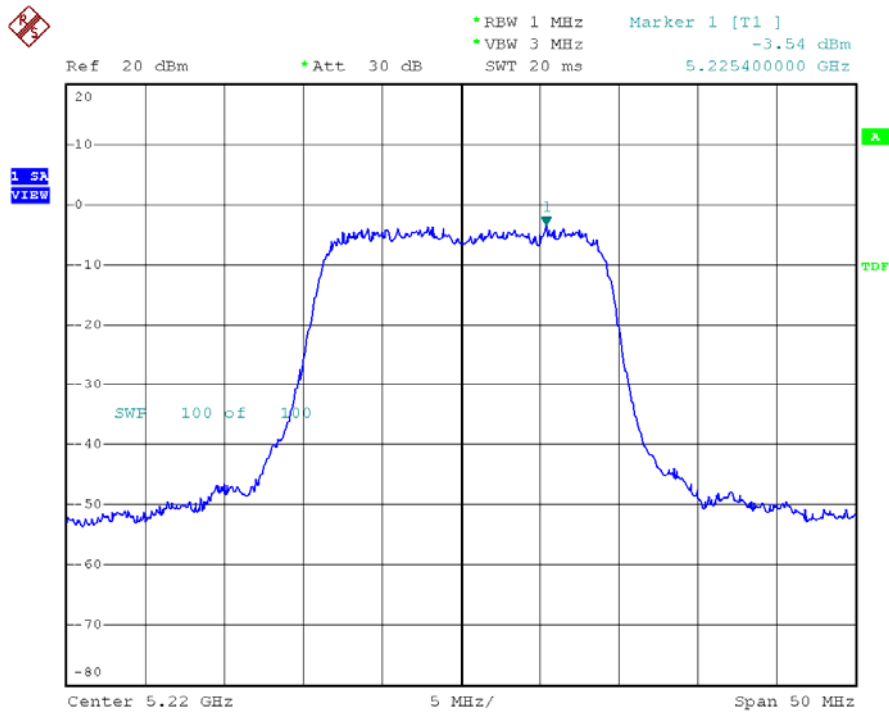

Modulation Standard: 802.11an HT20 (6.5Mbps), Antenna: R
Channel: 48

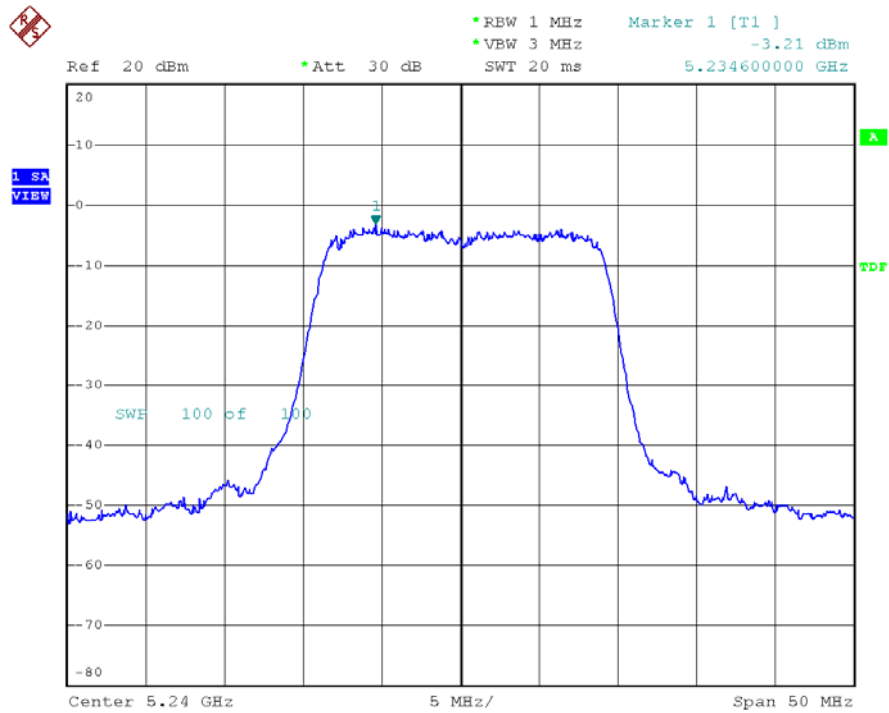



Modulation Standard: 802.11an HT40 (13.5Mbps), Antenna: L
Channel: 38

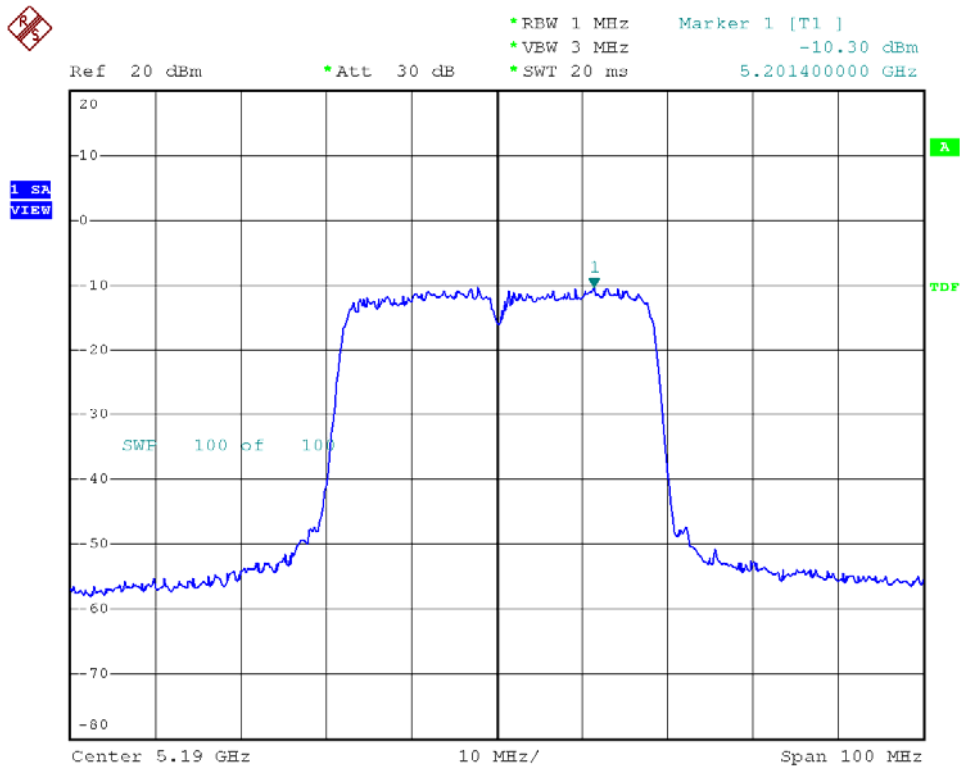

Modulation Standard: 802.11an HT40 (13.5Mbps), Antenna: L
Channel: 46

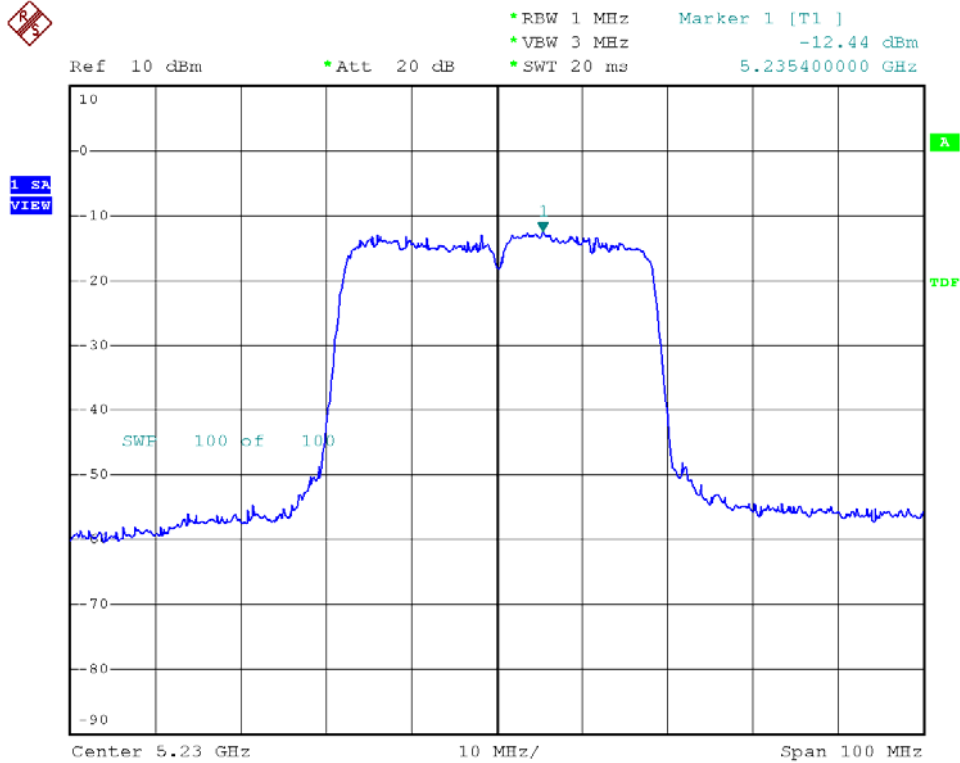



Modulation Standard: 802.11an HT40 (13.5Mbps), Antenna: R
Channel: 38

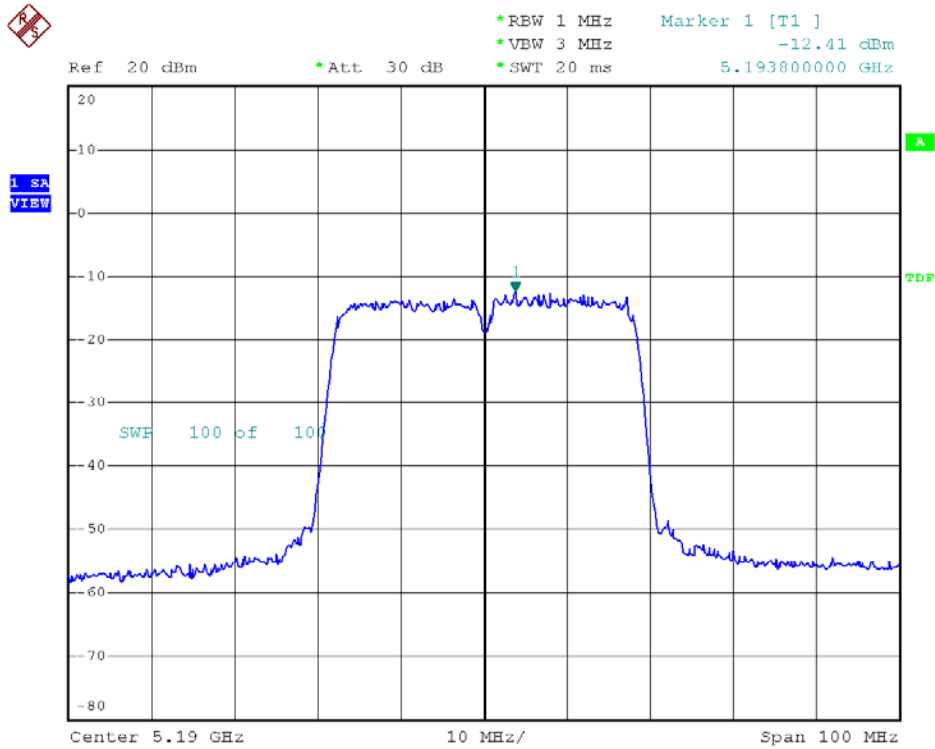

Modulation Standard: 802.11an HT40 (13.5Mbps), Antenna: R
Channel: 46

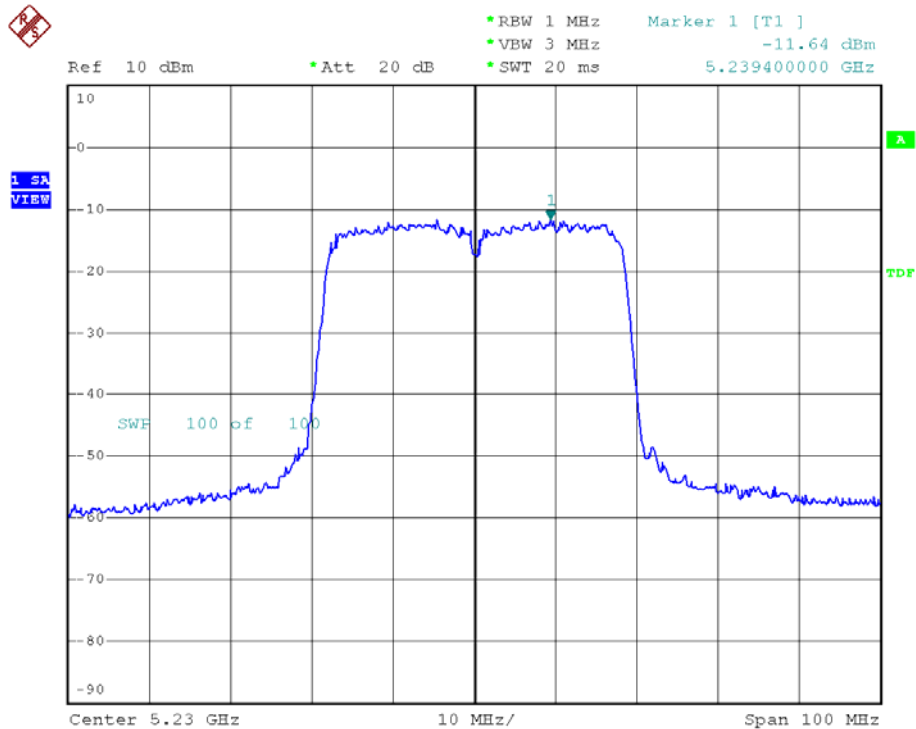



9. Frequency Stability

9.1. Test Procedure

1. The EUT was placed inside the Temperature and Humidity chamber.
2. The transmitter output was connected to spectrum analyzer.
3. Turn the EUT on and couple its output to a spectrum analyzer.
4. Turn the EUT off and set the chamber to the highest temperature specified.
5. Allow sufficient time (approximately 30 min) for the temperature of the chamber to stabilize, turn the EUT on and measure the operating frequency after 2, 5, and 10 minutes.
6. Repeat step 2 and 3 with the temperature chamber set to the lowest temperature.
7. The test chamber was allowed to stabilize at +20 degree C for a minimum of 30 minutes. The supply voltage was then adjusted on the EUT from 85% to 115% and the frequency record.

9.2. Test Setup Layout

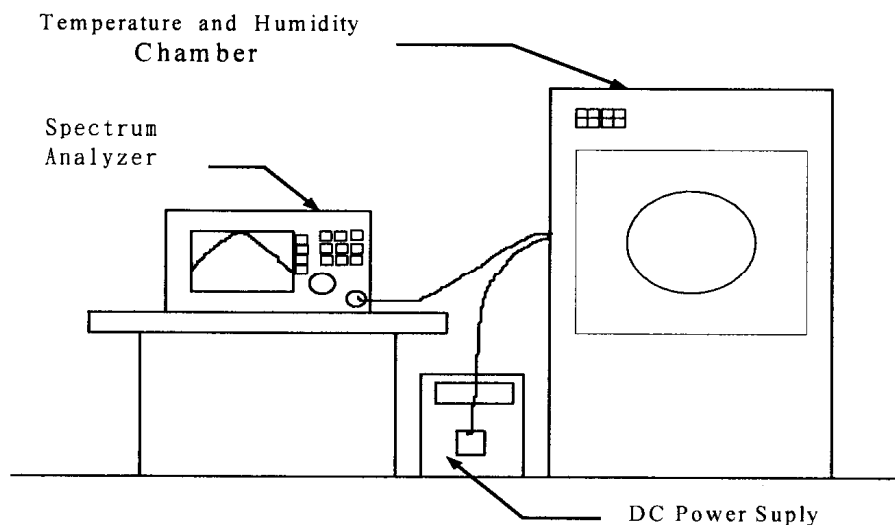

9.3. Measurement Equipment

Instrument/Ancillary	Model No.	Manufacturer	Serial No.	Calibration Date	Valid Date.
Spectrum Analyzer	FSP40	R&S	10047	2008/02/22	2009/02/21
Temperature Chamber	TMJ-9712	T MACHINE	T-12-040111	2008/01/15	2009/01/14
DC Power Supply	GPD-3030	GM	7020936	N/A	N/A
AC POWER CONVERTER	AFC-11005	APC	F103120008	N/A	N/A

**9.4. Test Result and Data**

Operating frequency: 5230 MHz							
Temp (°C)	Power supply (V)	2 minute		5 minute		10 minute	
		(MHz)	(%)	(MHz)	(%)	(MHz)	(%)
50	93.5	5230.0108	0.000207	5229.9213	-0.001505	5229.9895	-0.000201
	110.0	5230.0019	0.000036	5229.9482	-0.000990	5229.9653	-0.000663
	126.5	5230.0001	0.000002	5229.9519	-0.000920	5229.9763	-0.000453
40	93.5	5229.9841	-0.000304	5229.9849	-0.000289	5230.0052	0.000099
	110.0	5229.9812	-0.000359	5230.0229	0.000438	5229.9781	-0.000419
	126.5	5229.9723	-0.000530	5229.9851	-0.000285	5229.9783	-0.000415
30	93.5	5230.0174	0.000333	5230.0007	0.000013	5229.9962	-0.000073
	110.0	5230.0278	0.000532	5230.0005	0.000010	5229.9871	-0.000247
	126.5	5229.9966	-0.000065	5230.0127	0.000243	5229.9719	-0.000537
20	93.5	5230.0272	0.000520	5230.0033	0.000063	5230.0018	0.000034
	110.0	5230.0054	0.000103	5229.9853	-0.000281	5230.0111	0.000212
	126.5	5230.0147	0.000281	5230.0082	0.000157	5229.9718	-0.000539
10	93.5	5230.0017	0.000033	5230.0071	0.000136	5230.0062	0.000119
	110.0	5230.0215	0.000411	5229.9667	-0.000637	5230.0155	0.000296
	126.5	5230.0141	0.000270	5230.0019	0.000036	5229.9943	-0.000109
0	93.5	5230.0012	0.000023	5229.9841	-0.000304	5229.9734	-0.000509
	110.0	5230.0159	0.000304	5229.9726	-0.000524	5229.9871	-0.000247
	126.5	5229.9953	-0.000090	5229.9698	-0.000577	5229.9796	-0.000390
-10	93.5	5229.9664	-0.000642	5229.9729	-0.000518	5230.0204	0.000390
	110.0	5229.9574	-0.000815	5230.0151	0.000289	5230.0149	0.000285
	126.5	5229.9786	-0.000409	5229.9898	-0.000195	5229.9888	-0.000214
-20	93.5	5230.0214	0.000409	5230.0047	0.000090	5230.0178	0.000340
	110.0	5230.0144	0.000275	5230.0031	0.000059	5230.0277	0.000530
	126.5	5229.9885	-0.000220	5230.0114	0.000218	5230.0168	0.000321
-30	93.5	5230.0176	0.000337	5230.0022	0.000042	5230.0024	0.000046
	110.0	5230.0237	0.000453	5230.0021	0.000040	5230.0175	0.000335
	126.5	5230.0128	0.000245	5230.0042	0.000080	5230.0294	0.000562

Limit :

Manufacturers of U-NII devices are responsible for ensuring frequency stability such that an emission is maintained within the band of operation under all conditions of normal operation as specified in the users manual.



10. Band Edges Measurement

10.1. Test Procedure

1. The transmitter output was connected to the spectrum analyzer via a low lose cable.
2. Set both RBW and VBW of spectrum analyzer to 100 KHz with convenient frequency span including 100 MHz bandwidth from band edge
3. The band edges was measured and recorded.

10.2. Measurement Equipment

Instrument/Ancillary	Model No.	Manufacturer	Serial No.	Calibration Date	Valid Date
Spectrum Analyzer	FSP40	R&S	10047	2008/02/22	2009/02/21

10.3. Test Result and Data

Test Date: Nov. 08, 2008

Temperature: 20

Atmospheric pressure: 1008 hPa

Humidity: 60%

Modulation Standard	Channel	Frequency (MHz)	maximum value in frequency (MHz)		maximum value (dBm)	
			L	R	L	R
802.11a (6Mbps)	36	5180	5147.80	5148.60	-44.38	-43.09
802.11an HT20 (6.5Mbps)	36	5180	5145.80	5146.20	-44.90	-43.48
802.11an HT40 (13.5Mbps)	38	5190	5146.20	5149.40	-45.53	-45.80



Modulation Standard: 802.11a (6Mbps), Antenna: L
Channel: 36

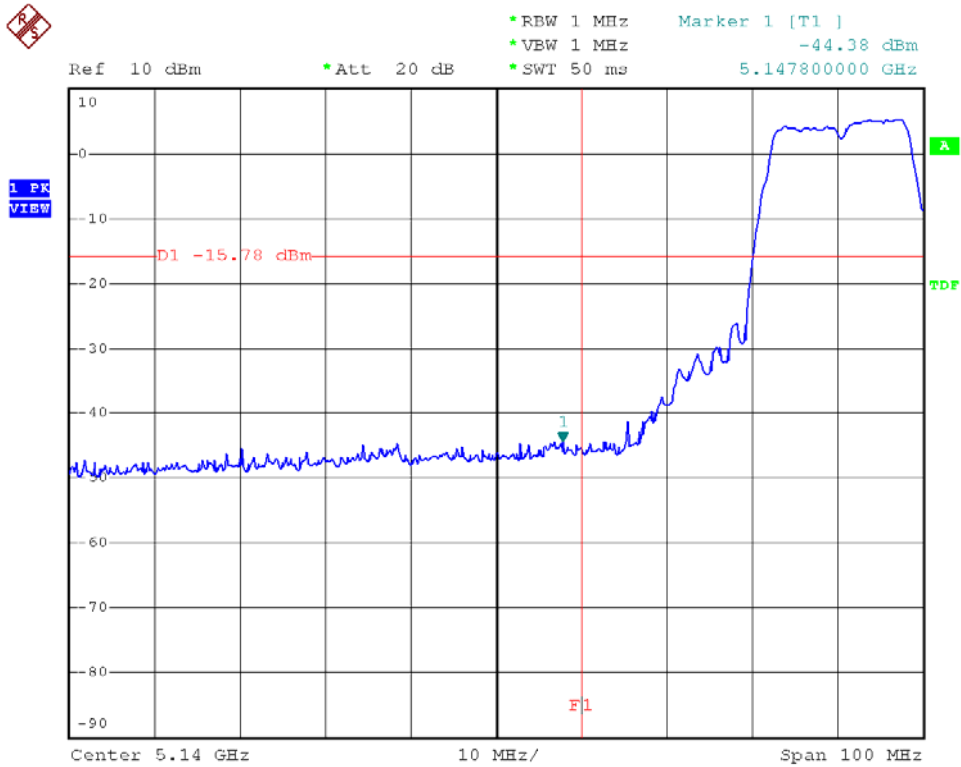

Modulation Standard: 802.11a (6Mbps), Antenna: R
Channel: 36

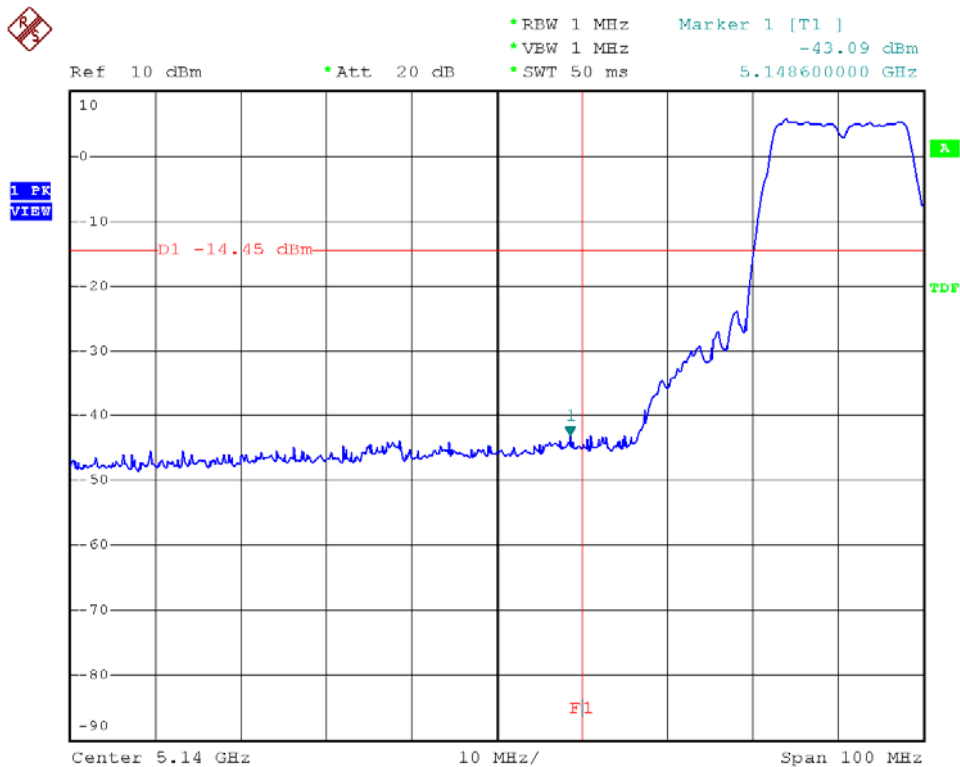



Modulation Standard: 802.11an HT20 (6.5Mbps), Antenna: L
Channel: 36

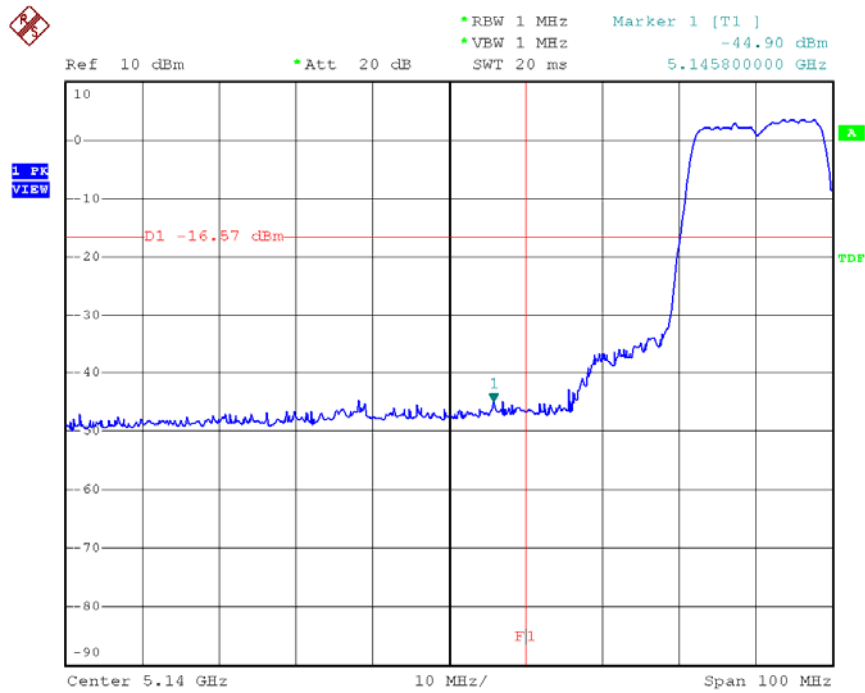

Modulation Standard: 802.11an HT20 (6.5Mbps), Antenna: R
Channel: 36

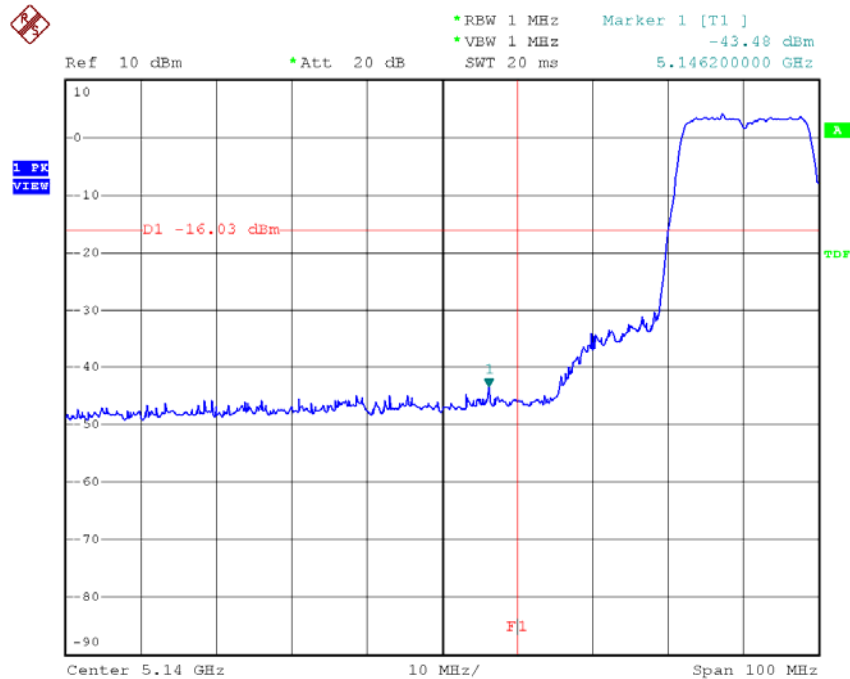



Modulation Standard: 802.11an HT40 (13.5Mbps), Antenna: L
Channel: 38

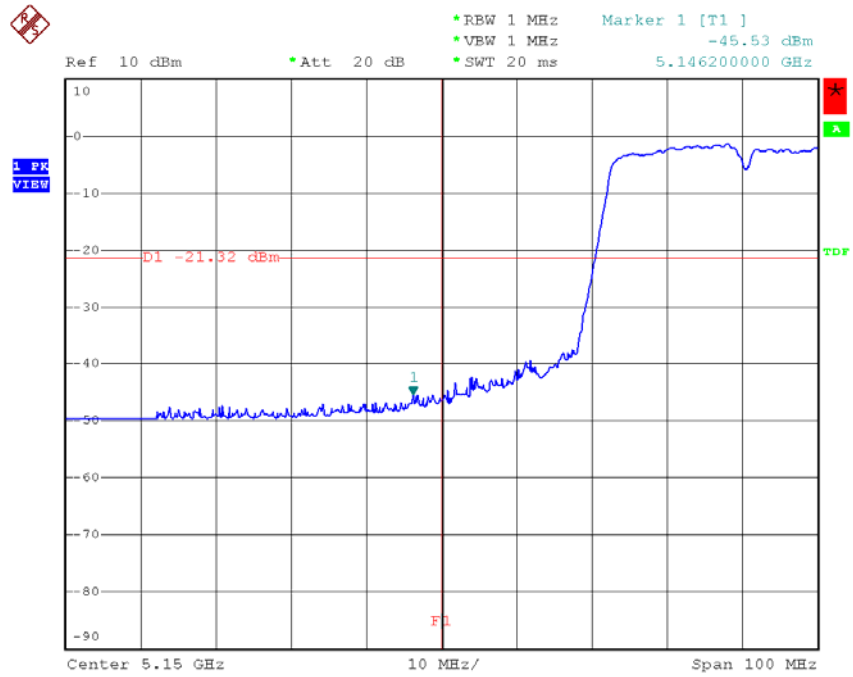

Modulation Standard: 802.11an HT40 (13.5Mbps), Antenna: R
Channel: 38

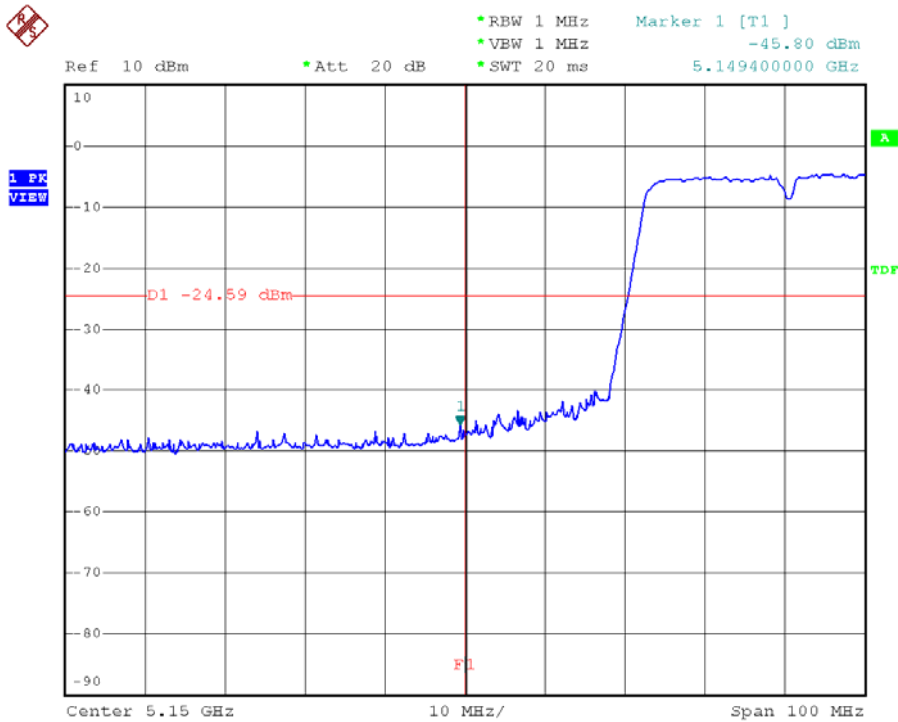



10.4. Restrict Band Emission Measurement Data

Test Date : Nov. 13, 2008 Temperature : 22
 Atmospheric pressure : 1010 hPa Humidity : 70%

Modulation Standard: IEEE 802.11a (6Mbps)

Channel 36						Fundamental Frequency: 5180 MHz				
Frequency (MHz)	Ant-Pol H/V	Meter Reading (dBuV)	Corrected Factor (dB)	Result (dBuV/m)	Remark	Limit (dBuV/m)		Margin (dB)	Table Deg.	Ant High (m)
						Peak	Ave			
5137.90	H	49.02	4.98	54.00	Peak	74	54	-20.00	120	1.00
5147.70	H	37.63	5.00	42.63	Ave	74	54	-11.37	120	1.00
5147.20	V	50.46	4.99	55.45	Peak	74	54	-18.55	139	1.18
5147.40	V	38.55	4.99	43.54	Ave	74	54	-10.46	139	1.18

Modulation Standard: IEEE 802.11an, HT20(6.5Mbps)

Channel 36						Fundamental Frequency: 5180 MHz				
Frequency (MHz)	Ant-Pol H/V	Meter Reading (dBuV)	Corrected Factor (dB)	Result (dBuV/m)	Remark	Limit (dBuV/m)		Margin (dB)	Table Deg.	Ant High (m)
						Peak	Ave			
5137.20	H	48.80	4.97	53.78	Peak	74	54	-20.22	120	1.00
5147.90	H	37.63	5.00	42.62	Ave	74	54	-11.38	120	1.00
5145.40	V	50.85	4.99	55.84	Peak	74	54	-18.16	139	1.18
5147.70	V	38.64	5.00	43.64	Ave	74	54	-10.36	139	1.18

Modulation Standard: IEEE 802.11an, HT40(13.5Mbps)

Channel 38						Fundamental Frequency: 5190 MHz				
Frequency (MHz)	Ant-Pol H/V	Meter Reading (dBuV)	Corrected Factor (dB)	Result (dBuV/m)	Remark	Limit (dBuV/m)		Margin (dB)	Table Deg.	Ant High (m)
						Peak	Ave			
5148.40	H	49.06	5.00	54.06	Peak	74	54	-19.94	120	1.00
5149.90	H	37.65	5.00	42.65	Ave	74	54	-11.35	120	1.00
5132.90	V	50.50	4.97	55.47	Peak	74	54	-18.53	139	1.18
5149.70	V	38.76	5.00	43.76	Ave	74	54	-10.24	139	1.18

Notes:

1. Result = Meter Reading + Factor
2. Factor = Antenna Factor + Cable Loss – Amplifier
3. The resolution bandwidth of test receiver/spectrum analyzer is 1MHz and video bandwidth is 3 MHz for Peak detection at frequency above 1GHz.
4. The resolution bandwidth of test receiver/spectrum analyzer is 1MHz and video bandwidth is 10 MHz for Average detection at frequency above 1GHz.



11. Restricted Bands of Operation

Only spurious emissions are permitted in any of the frequency bands listed below:

MHz	MHz	MHz	GHz
0.09000 – 0.11000	16.42000 – 16.42300	399.9 – 410.0	4.500 – 5.250
0.49500 – 0.505**	16.69475 – 16.69525	608.0 – 614.0	5.350 – 5.460
2.17350 – 2.19050	16.80425 – 16.80475	960.0 – 1240.0	7.250 – 7.750
4.12500 – 4.12800	25.50000 – 25.67000	1300.0 – 1427.0	8.025 – 8.500
4.17725 – 4.17775	37.50000 – 38.25000	1435.0 – 1626.5	9.000 – 9.200
4.20725 – 4.20775	73.00000 – 74.60000	1645.5 – 1646.5	9.300 – 9.500
6.21500 – 6.21800	74.80000 – 75.20000	1660.0 – 1710.0	10.600 – 12.700
6.26775 – 6.26825	108.00000 – 121.94000	1718.8 – 1722.2	13.250 – 13.400
6.31175 – 6.31225	123.00000 – 138.00000	2200.0 – 2300.0	14.470 – 14.500
8.29100 – 8.29400	149.90000 – 150.05000	2310.0 – 2390.0	15.350 – 16.200
8.36200 – 8.36600	156.52475 – 156.52525	2483.5 – 2500.0	17.700 – 21.400
8.37625 – 8.38675	156.70000 – 156.90000	2655.0 – 2900.0	22.010 – 23.120
8.41425 – 8.41475	162.01250 – 167.17000	3260.0 – 3267.0	23.600 – 24.000
12.29000 – 12.29300	167.72000 – 173.20000	3332.0 – 3339.0	31.200 – 31.800
12.51975 – 12.52025	240.00000 – 285.00000	3345.8 – 3358.0	36.430 – 36.500
12.57675 – 12.57725	322.00000 – 335.40000	3600.0 – 4400.0	Above 38.6
13.36000 – 13.41000			

** : Until February 1, 1999, this restricted band shall be 0.490-0.510 MHz

11.1. Labeling Requirement

The device shall bear the following statement in a conspicuous location on the device:

This device complies with part 15 of the FCC Rules. Operation is subject to the following two conditions: (1) This device may not cause harmful interference, and (2) this device must accept any interference received, including interference that may cause undesired operation.



12. RF Exposure

FCC Rules and Regulations Part 1.1307, 1.1310, 2.1091, 2.1093:

RF Exposure Compliance

12.1. Limit for Maximum Permissible Exposure (MPE)

(A) Limits for Occupational / Controlled Exposure

Frequency Range (MHz)	Electric Field Strength (E) (V/m)	Magnetic Field Strength (H) (A/m)	Power Density (S) (mW/ cm ²)	Averaging Time E ² , H ² or S (minutes)
0.3-3.0	614	1.63	(100)*	6
3.0-30	1842/f	4.89/f	(900/f)*	6
30-300	61.4	0.163	1.0	6
300-1500			F/300	6
1500-100,000			5	6

(B) Limits for General Population / Uncontrolled Exposure

Frequency Range (MHz)	Electric Field Strength (E) (V/m)	Magnetic Field Strength (H) (A/m)	Power Density (S) (mW/cm ²)	Averaging Time E ² , H ² or S (minutes)
0.3-1.34	614	1.63	(100)*	30
1.34-30	824/f	2.19/f	(180/f)*	30
30-300	27.5	0.073	0.2	30
300-1500			F/1500	30
1500-100,000			1.0	30

F=frequency in MHz

*Plane-wave equivalent power density



12.2. MPE Calculations

$$E \text{ (V/m)} = \frac{\sqrt{30 \times P \times G}}{d} \quad \text{Power Density: } Pd \text{ (mW/cm}^2\text{)} = \frac{E^2}{3770}$$

E = Electric field (V/m)

P = Peak output power (W)

G = Antenna numeric gain (numeric)

d = Separation distance (m)

Because the EUT is belong to General Population/ Uncontrolled Exposure. So the Limit of Power Density is 10 W/m². We can change the formula to:

$$d = \sqrt{\frac{30 \times P \times G}{3770}}$$

12.3. FCC Radiation Exposure Statement

This equipment complies with FCC radiation exposure limits set forth for an uncontrolled environment. In order to avoid the possibility of exceeding the FCC radio frequency exposure limits, human proximity to the antenna shall not be less than 20cm (8 inches) during normal operation. Proposed RF exposure safety information to include in User's Manual.