

FCC TEST REPORT

according to

FCC Rules and Regulations

Part 15 Subpart C

Applicant	: NETGEAR, INC.
Address	: 4500 GREAT AMERICA PARKWAY, SANTA CLARA, CA 95054 U.S.A.
Equipment	: RangeMax Next Wireless ADSL2+ Modem Router
Model No.	: DG834NU v2
Series No.	: DG834NUB v2, DG834N v2, DG834NB v2
FCC ID	: PY308100082
Trade Name	: NETGEAR

Laboratory Accreditation



- The test result refers exclusively to the test presented test model / sample.,
- Without written approval of **Exclusive Certification Corp.** the test report shall not be reproduced except in full.
- The EUT is also considered as a kind of computer peripheral, because the connection to computer is necessary for typical use. It has been verified to comply with the requirements of FCC Part 15, Subpart B, Class B (DoC). The test report has been issued separately.

Contents

1. Report of Measurements and Examinations	5
1.1 List of Measurements and Examinations	5
2. Test Configuration of Equipment under Test	6
2.1 Feature of Equipment under Test.....	6
2.2 RF Specifications	7
2.3 Carrier Frequency of Channels	7
2.4 Test Mode and Test Software.....	8
2.5 Description of Test System.....	9
2.6 Connection Diagram of Test System.....	10
2.7 General Information of Test.....	11
2.8 Measurement Uncertainty	11
2.9 History of this test report	12
3. Antenna Requirements	13
3.1 Standard Applicable	13
3.2 Antenna Construction and Directional Gain.....	13
4. Test of Conducted Emission	14
4.1 Test Limit	14
4.2 Test Procedures	14
4.3 Typical Test Setup	15
4.4 Measurement equipment	15
4.5 Test Result and Data.....	16
4.6 Test Photographs	34
5. Test of Radiated Emission	35
5.1 Test Limit	35
5.2 Test Procedures	35
5.3 Typical Test Setup	36
5.4 Measurement equipment	36
5.5 Test Result and Data.....	37
5.6 Test Photographs	145
6. 6dB Bandwidth Measurement Data	146
6.1 Test Limit	146
6.2 Test Procedures	146
6.3 Test Setup Layout	146
6.4 Measurement equipment	146
6.5 Test Result and Data.....	146
7. Maximum Peak Output Power	160
7.1 Test Limit	160
7.2 Test Procedures	160
7.3 Test Setup Layout	160
7.4 Measurement equipment	160
7.5 Test Result and Data.....	160
8. Band Edges Measurement	174
8.1 Test Limit	174
8.2 Test Procedure :	174
8.3 Test Setup Layout	174
8.4 Measurement equipment	174

8.5 Test Result and Data..... 174

8.6 Restrict band emission Measurement Data..... 192

9. Power Spectral Density 198

9.1 Test Limit 198

9.2 Test Procedures 198

9.3 Test Setup Layout : 198

9.4 Measurement equipment 198

9.5 Test Result and Data..... 198

10. Restricted Bands of Operation 212

10.1 Labeling Requirement..... 212

Appendix A. Photographs of EUT..... A1 ~ A16

CERTIFICATE OF COMPLIANCE

according to

FCC Rules and Regulations

Part 15 Subpart C

Applicant : NETGEAR, INC.
Address : 4500 GREAT AMERICA PARKWAY, SANTA CLARA,
CA 95054 U.S.A.
Equipment : RangeMax Next Wireless ADSL2+ Modem Router
Model No. : DG834NU v2
Series No. : DG834NUB v2, DG834N v2, DG834NB v2
FCC ID : PY308100082

I **HEREBY** CERTIFY THAT :

The measurements shown in this test report were made in accordance with the procedures given in **ANSI C63.4** The equipment was **passed** the test performed according to **FCC Rules and Regulations Part 15 Subpart C (2007)**.

The test was carried out on May. 16, 2008 at **Exclusive Certification Corp.**

Signature

Anson Chou / Manager

1. Report of Measurements and Examinations

1.1 List of Measurements and Examinations

FCC Rule	Description of Test	Result
15.203	. Antenna Requirement	Pass
15.207	. Conducted Emission	Pass
15.209 15.247(d)	. Radiated Emission	Pass
15.247(a)(2)	. 6dB Bandwidth	Pass
15.247(b)	. Maximum Peak Output Power	Pass
15.247(d)	. 100kHz Bandwidth of Frequency Band Edges	Pass
15.247(e)	. Power Spectral Density	Pass
1.1307 1.1310 2.1091 2.1093	. RF Exposure Compliance	Pass

2. Test Configuration of Equipment under Test

2.1 Feature of Equipment under Test

Specification	Description
Network Protocol and Standards Compatibility	
Data and routing protocols:	TCP/IP, RIP-1, RIP-2, DHCP, PPPoE or PPPoA, RFC 1483 Bridged or Routed Ethernet, and RFC 1577 Classical IP over ATM
Power Adapter	
North America:	120V, 60 Hz, input
UK, Australia:	240v, 50 Hz, input
Europe:	230V, 50 Hz, input
All regions (output):	12V AC @ 1.0A output
Physical	
Dimensions:	8.9" x 6.8" x 1.5" 225.5 mm x 172 mm x 39 mm
Weight:	1.2 lbs. 0.54 kg
Environmental	
Operating temperature:	0° to 40° C (32° to 104° F)
Operating humidity:	10% to 90% relative humidit, noncondensing
Storage temperature	-20° to 70° C (-4° to 158° F)
Storage humidity:	5 to 95% relative humidity, noncondensing
Interface Specifications	
LAN:	10BASE-T or 100BASE-Tx, RJ-45
WAN:	ADSL, Dual RJ-11, pins 2 and 3 T1.413, G.DMT, G.Lite ITU Annex A or B ITU G.992.5 (ADSL 2+)

2.2 RF Specifications

Spreading 802.11b: DSSS, CCK, QPSK, BPSK 802.11g: OFDM (64QAM, 16QAM, QPSK, BPSK) 802.11n, HT20: OFDM (64QAM, 16QAM, QPSK, BPSK) 802.11n, HT40: OFDM (64QAM, 16QAM, QPSK, BPSK)
Frequency Range 2.4 ~ 2.4835 GHz
Number of Channels USA, Canada and Taiwan: 1 ~ 11 for 802.11b/g/n,20MHz, 3~9 for 802.11n, 40MHz Most European Countries: 1 ~ 13 for 802.11b/g/n,20MHz, 3~9 for 802.11n, 40MHz
Data Rate 802.11b: 11, 5.5, 2, 1Mbps 802.11g: 54, 48, 36, 24, 18, 12, 9, 6 Mbps 802.11n, HT20: 135 ~ 6.5 Mbps 802.11n, HT40: 270 ~ 13.5 Mbps
Modulation 802.11b: DSSS, CCK, QPSK, BPSK 802.11g: OFDM (64QAM, 16QAM, QPSK, BPSK) 802.11n, HT20: OFDM (64QAM, 16QAM, QPSK, BPSK) 802.11n, HT40: OFDM (64QAM, 16QAM, QPSK, BPSK)
Antenna L, R Antenna Type: Dipole Antenna Antenna L Gain: 1.8 dBi / Antenna R Gain: 1.8dBi
Transmit Power FCC: 802.11b: 17 dBm / 802.11g: 15 dBm / 802.11n: 12.5 dBm ETSI: (EIRP) 802.11b: 18.8 dBm / 802.11g: 16.8 dBm / 802.11n: 13.8 dBm

2.3 Carrier Frequency of Channels

802.11b, 802.11g, 802.11n, HT20

Channel	Frequency(MHz)	Channel	Frequency(MHz)
01	2412	07	2442
02	2417	08	2447
03	2422	09	2452
04	2427	10	2457
05	2432	11	2462
06	2437	---	---

802.11n, HT40

Channel	Frequency(MHz)	Channel	Frequency(MHz)
---	---	07	2442
---	---	08	2447
03	2422	09	2452
04	2427	---	---
05	2432	---	---
06	2437	---	---

2.4 Test Mode and Test Software

- a. During testing, the interface cables and equipment positions were varied according to ANSI C63.4.
- b. The complete test system included remote workstation, IBM PC, Monitor, PS2 Keyboard, USB Mouse, Flash Memory, Modem, Printer and EUT for RF test.
- c. An executive program, EMITEST.EXE under WIN XP, which generates a complete line of continuously repeating "H" pattern was used as the test software.

The program was executed as follows:

1. Turn on the power of all equipment.
 2. The PC reads the test program from the hard disk drive and runs it.
 3. The PC sends "H" messages to the monitor, and the monitor displays "H" patterns on the screen.
 4. The PC sends "H" messages to the internal Hard Disk, and the Hard Disk reads and writes the message.
 5. The PC sends "H" messages to the modem.
 6. The PC sends "H" messages to the printer.
 7. Repeat the steps from 2 to 6.
- d. An executive program, telnet.exe under WIN XP, which generates a continuous signal by the following frequency to test.
 - 802.11b/g:
CH01: 2412MHz, CH06: 2437MHz, CH11: 2462MHz
 - 802.11n, HT20:
CH01: 2412MHz, CH06: 2437MHz, CH11: 2462MHz
 - 802.11n, HT40:
CH03: 2422MHz, CH06: 2437MHz, CH09: 2452MHz
 - e. The following test included three kinds of power adapter:
Test Mode 1: DSA-20P-10 US 120180.
Test Mode 2: MU18-2120150-A1.
Test Mode 3: MT12-Y120100-A1.

2.5 Description of Test System

Device	Manufacturer	Model No.	Description
PC	IBM	IGV	Power Cable, Unshielding 1.8 m
Monitor	SlimAGE	510A	Power Cable, Adapter Unshielding 1.8 m Data Cable, VGA Shielding 1.35 m
Keyboard	IBM	KB-0225	Data Cable, PS2 Shielding 1.85 m
Mouse	IBM	MU29J	Data Cable, PS2 Shielding 1.85 m
Modem	ACEXX	DM-1414	Power Cable, Adapter Unshielding 1.8 m Data Cable, RS232 Shielding 1.35 m
Printer	hp	Desk Jet 400	Power Cable, Adapter Unshielding 1.8 m Data Cable, PRINT Shielding 1.6 m
Flash Memory	ZYRUS	nextik pro 1GB	N/A
Notebook (Remote Workstation)	TOSHIBA	PSA50T-05M00C	Power Cable, Adapter Unshielding 1.8 m
CO (A) (Remote Workstation)	ZYXEL	IES-1000	Power Cable, Unshielding 1.8 m

Use Cable:

Cable	Quality	Description
RJ45	1	Unshielding, 1.5m
RJ45	3	Unshielding, 3.0m
RJ45	1	Unshielding, 5.0m
RJ11	1	Unshielding, 5.0m

2.6 Connection Diagram of Test System

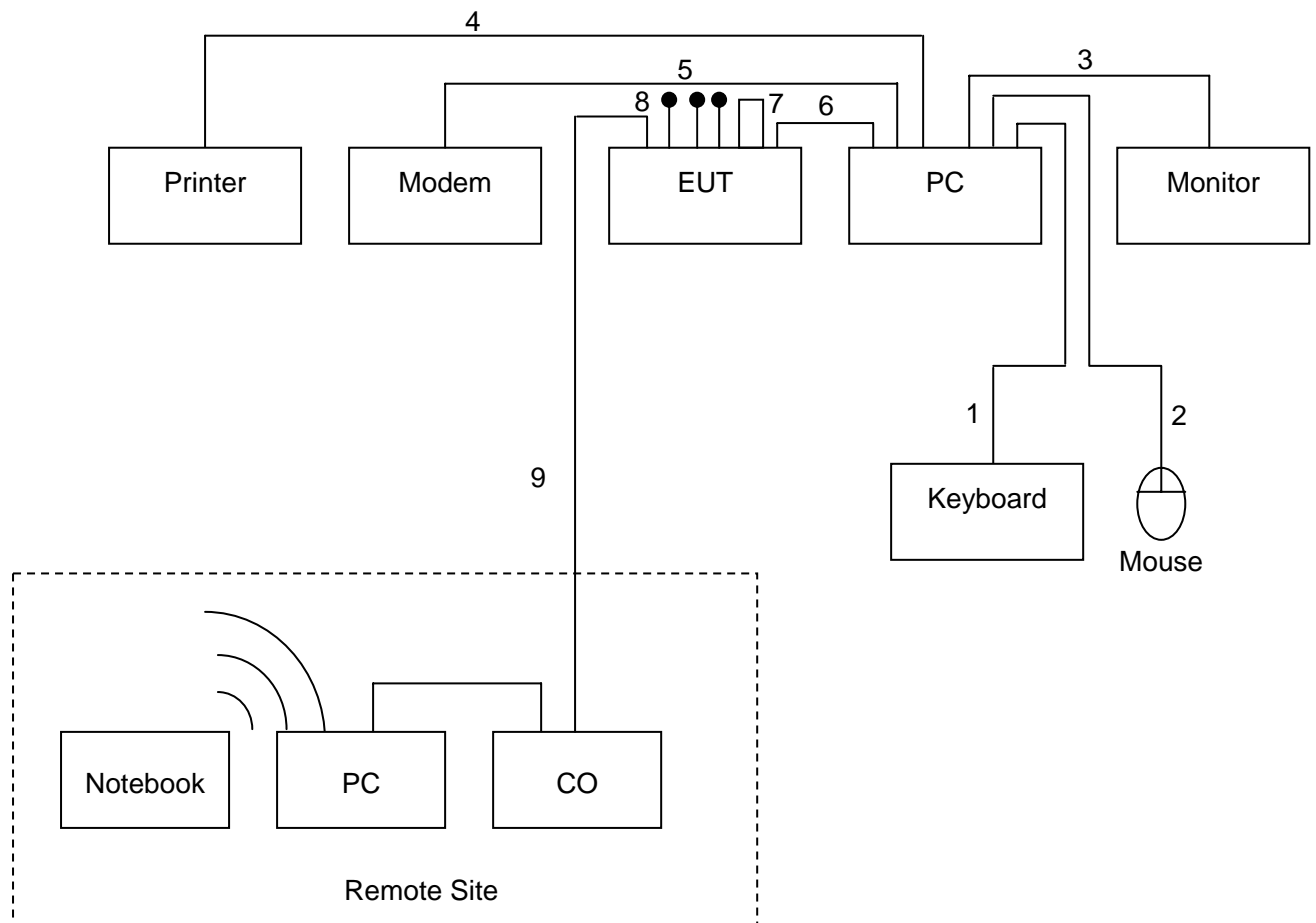

1. The PS2 cable is connected from PC to the Keyboard.
2. The PS2 cable is connected from PC to the Mouse.
3. The VGA cable is connected from PC to the Monitor.
4. The PRINT cable is connected from PC to the Printer.
5. The RS232 cable is connected from PC to the Modem.
6. The RJ45 cable is connected from PC to the EUT.
7. The Flash memory is connected to EUT by USB Port.
8. Those RJ45 cables are floating.
9. The RJ11 cable is connected from EUT to the CO.

2.7 General Information of Test

Test Site :	Exclusive Certification Corp. 4F-2, No. 28, Lane 78, Xing-Ai Rd. Nei-hu, Taipei City 114 Taiwan R.O.C.
Test Site Location (OATS1-SD):	No.68-1, Shihbachongsi, shihding Township, Taipei City 223, Taiwan, R.O.C. Registration Number: 632249.
FCC Registration Number :	632249
IC Registration Number :	6597A-1
VCCI Registration Number :	T-338 for Telecommunication Test C-2188 for Conducted emission test R-1902 for Radiated emission test
Test Voltage:	AC 120V
Test in Compliance with:	ANSI C63.4-2003 FCC Part 15 Subpart C
Frequency Range Investigated:	Conducted: from 150kHz to 30MHz Radiation: from 30MHz to 24620MHz
Test Distance:	The test distance of radiated emission from antenna to EUT is 3 M.

2.8 Measurement Uncertainty

Measurement Item	Measurement Frequency	Polarization	Uncertainty
Conducted Emission	9 kHz ~ 30 MHz	LINE/NEUTRAL	2.71 dB
Radiated Emission	30 MHz ~ 1GHz	Vertical	4.11 dB
		Horizontal	4.10 dB
6 dB Bandwidth	---	---	7500 Hz
Maximum Peak Output Power	---	---	1.4 dB
100kHz Bandwidth of Frequency Band Edges	---	---	2.2 dB
Power Spectral Density	---	---	2.2 dB

2.9 History of this test report

ORIGINAL.

Additional attachment as following record:

Attachment No.	Issue Date	Description

3. Antenna Requirements

3.1 Standard Applicable

For intentional device, according to FCC 47 CFR Section 15.203, an intentional radiator shall be designed to ensure that no antenna other than that furnished by the responsible party shall be used with the device.

And according to FCC 47 CFR Section 15.247 (b), if transmitting antennas of directional gain greater than 6dBi are used, the power shall be reduced by the amount in dB that the directional gain of the antenna exceeds 6dBi.

3.2 Antenna Construction and Directional Gain

ANT-L:

Antenna type: Integral Dipole Antenna

Antenna Gain: 1.8 dBi

ANT-R:

Antenna type: Integral Dipole Antenna

Antenna Gain: 1.8 dBi

4. Test of Conducted Emission

4.1 Test Limit

Conducted Emissions were measured from 150 kHz to 30 MHz with a bandwidth of 9 KHz on the 120 VAC power and return leads of the EUT according to the methods defined in ANSI C63.4-2003 Section 3.1. The EUT was placed on a nonmetallic stand in a shielded room 0.8 meters above the ground plane as shown in section 2.2. The interface cables and equipment positioning were varied within limits of reasonable applications to determine the position produced maximum conducted emissions.

Frequency (MHz)	Quasi Peak (dB μ V)	Average (dB μ V)
0.15 – 0.5	66-56*	56-46*
0.5 – 5.0	56	46
5.0 – 30.0	60	50

*Decreases with the logarithm of the frequency.

4.2 Test Procedures

- a. The EUT was placed 0.4 meter from the conducting wall of the shielding room was kept at least 80 centimeters from any other grounded conducting surface.
- b. Connect EUT to the power mains through a line impedance stabilization network (LISN).
- c. All the support units are connecting to the other LISN.
- d. The LISN provides 50 ohm coupling impedance for the measuring instrument.
- e. The FCC states that a 50 ohm, 50 micro-Henry LISN should be used.
- f. Both sides of AC line were checked for maximum conducted interference.
- g. The frequency range from 150 kHz to 30 MHz was searched.
- h. Set the test-receiver system to Peak Detect Function and Specified Bandwidth with Maximum Hold Mode.

4.3 Typical Test Setup

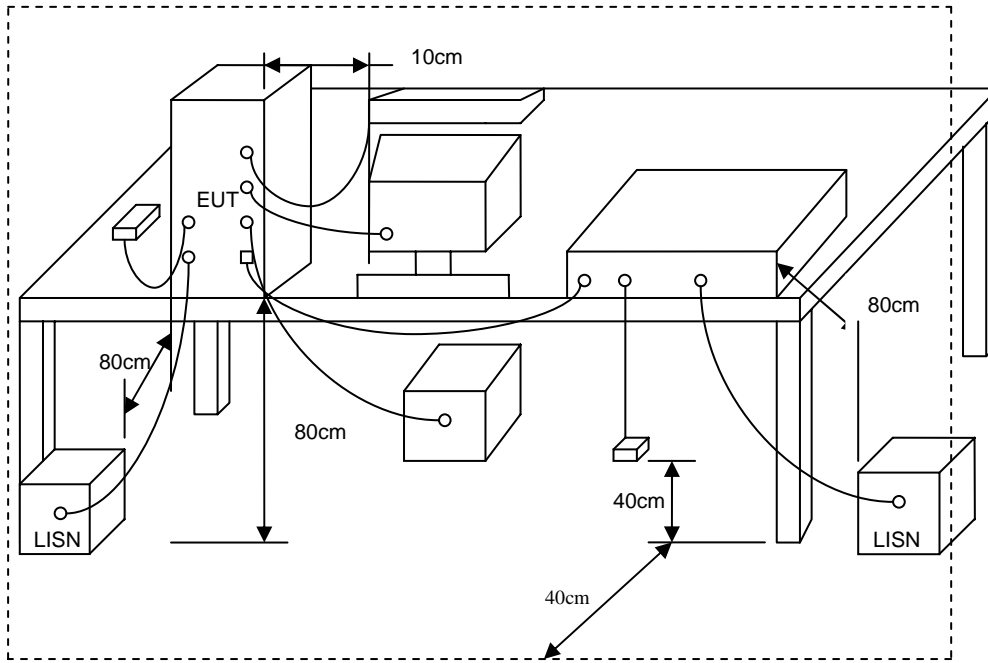

4.4 Measurement equipment

Instrument/Ancillary	Model No.	Manufacturer	Serial No.	Calibration Date	Valid Date.
Receiver	R&S	ESCI	100443	2007/09/27	2008/09/26
LISN	NNB-2/16Z	MESS TEC	02/10191	2008/05/14	2009/05/13
LISN	NNB-2/16Z	ROLF HEINE	03/10058	2008/04/19	2009/04/18

4.5 Test Result and Data

Power	: AC 120V	Pol/Phase	: LINE
Test Mode 1	: 802.11g CH1	Temperature	: 25 °C
Memo	: DSA-20P-10 US 120180	Humidity	: 55 %

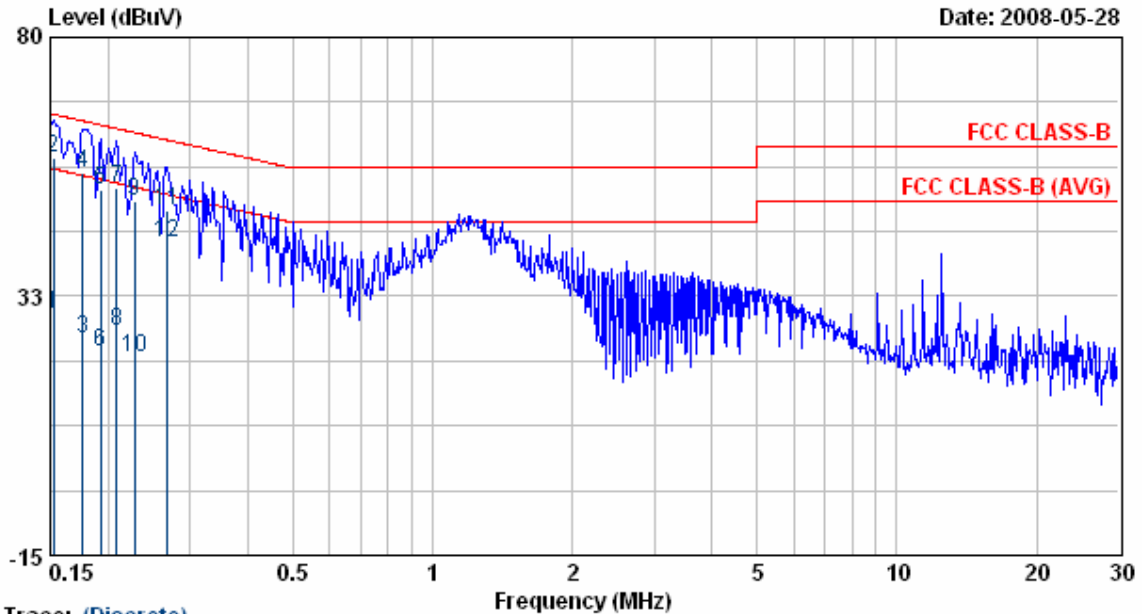

Trace: (Discrete)

Item	Freq	Read Value	Factor	Result	Limit	Margin	Remark
	MHz	dBuV	dB	dBuV	dBuV	dBuV	
1	0.15	29.11	0.10	29.21	55.87	-26.66	AVERAGE
2	0.15	57.82	0.10	57.92	65.87	-7.95	QP
3	0.18	24.63	0.10	24.73	54.68	-29.95	AVERAGE
4	0.18	54.93	0.10	55.04	64.68	-9.64	QP
5	0.19	51.86	0.10	51.97	63.93	-11.96	QP
6	0.19	22.26	0.10	22.37	53.93	-31.57	AVERAGE
7	0.21	52.28	0.11	52.38	63.27	-10.89	QP
8	0.21	25.96	0.11	26.06	53.27	-27.21	AVERAGE
9	0.23	49.71	0.11	49.81	62.52	-12.71	QP
10	0.23	21.09	0.11	21.20	52.52	-31.32	AVERAGE
11	0.27	48.20	0.11	48.31	61.16	-12.85	QP
12	0.27	42.29	0.11	42.41	51.16	-8.75	AVERAGE

- Remarks:
1. Level = Read Level + Factor
 2. Factor = LISN(ISN) Factor + Cable Loss
 3. All emission below 1GHz at 802.11b/g mode are all the same,so the 802.11g mode chosen as representative in final test.
 4. According to technical experiences,all spurious emission of 802.11g mode at channel 1,6,11 are almost the same below 1GHz,so that the channel 1 was chosen as representative in final test.
 5. The data is worse case.

Power	: AC 120V	Pol/Phase	: NEUTRAL
Test Mode 1	: 802.11g CH1	Temperature	: 25 °C
Memo	: DSA-20P-10 US 120180	Humidity	: 55 %

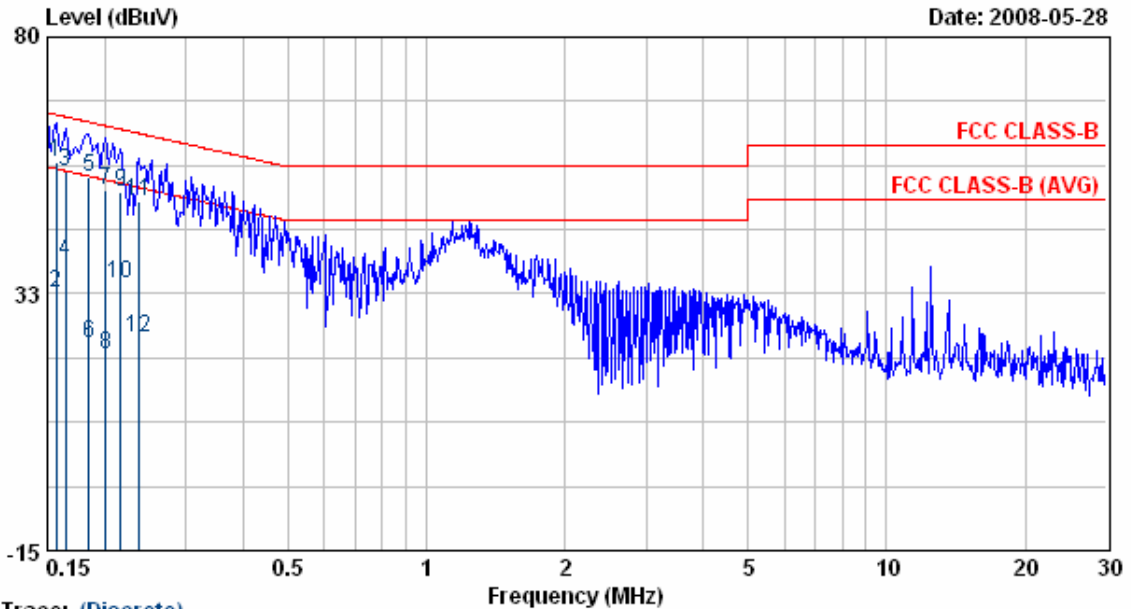

Trace: (Discrete)

Item	Freq	Read Value	Factor	Result	Limit	Margin	Remark
	MHz	dBuV	dB	dBuV	dBuV	dBuV	
1	0.16	56.65	0.09	56.74	65.65	-8.91	QP
2	0.16	32.50	0.09	32.59	55.65	-23.06	AVERAGE
3	0.16	54.93	0.09	55.02	65.25	-10.23	QP
4	0.16	38.46	0.09	38.55	55.25	-16.70	AVERAGE
5	0.18	54.10	0.09	54.19	64.28	-10.10	QP
6	0.18	23.24	0.09	23.33	54.28	-30.96	AVERAGE
7	0.20	51.72	0.09	51.81	63.58	-11.76	QP
8	0.20	21.10	0.09	21.19	53.58	-32.39	AVERAGE
9	0.22	51.08	0.09	51.17	62.96	-11.79	QP
10	0.22	34.41	0.09	34.50	52.96	-18.47	AVERAGE
11	0.24	49.63	0.09	49.72	62.22	-12.50	QP
12	0.24	24.30	0.09	24.39	52.22	-27.82	AVERAGE

- Remarks:
1. Level = Read Level + Factor
 2. Factor = LISN(ISN) Factor + Cable Loss
 3. All emission below 1GHz at 802.11b/g mode are all the same, so the 802.11g mode chosen as representative in final test.
 4. According to technical experiences, all spurious emission of 802.11g mode at channel 1, 6, 11 are almost the same below 1GHz, so that the channel 1 was chosen as representative in final test.
 5. The data is worse case.

Power	: AC 120V	Pol/Phase	: LINE
Test Mode 1	: 802.11n, HT20 CH1	Temperature	: 25 °C
Memo	: DSA-20P-10 US 120180	Humidity	: 55 %

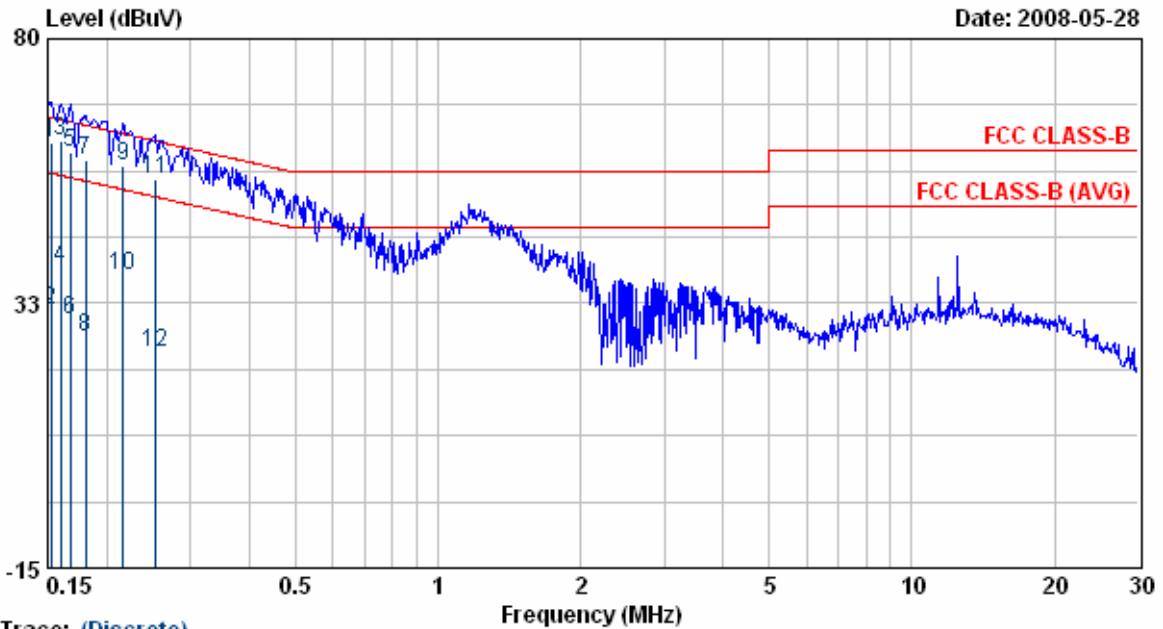

Trace: (Discrete)

Item	Freq	Read Value	Factor	Result	Limit	Margin	Remark
	MHz	dBuV	dB	dBuV	dBuV	dBuV	
1	0.15	61.11	0.10	61.21	65.87	-4.65	QP
2	0.15	31.33	0.10	31.43	55.87	-24.44	AVERAGE
3	0.16	61.45	0.10	61.55	65.47	-3.93	QP
4	0.16	38.88	0.10	38.98	55.47	-16.50	AVERAGE
5	0.17	59.49	0.10	59.59	65.08	-5.48	QP
6	0.17	29.34	0.10	29.44	55.08	-25.64	AVERAGE
7	0.18	58.22	0.10	58.32	64.46	-6.14	QP
8	0.18	26.34	0.10	26.44	54.46	-28.02	AVERAGE
9	0.22	57.13	0.11	57.24	62.96	-5.73	QP
10	0.22	37.24	0.11	37.34	52.96	-15.62	AVERAGE
11	0.25	54.52	0.11	54.63	61.69	-7.06	QP
12	0.25	23.47	0.11	23.58	51.69	-28.11	AVERAGE

Remarks:

1. Level = Read Level + Factor
2. Factor = LISN(ISN) Factor + Cable Loss
3. According to technical experiences, all spurious emission of 802.11MIMO mode at channel 1,6,11 are almost the same below 1GHz, so that the channel 1 was chosen as representative in final test.
4. The data is worse case.

Power	: AC 120V	Pol/Phase	: NEUTRAL
Test Mode 1	: 802.11n, HT20 CH1	Temperature	: 25 °C
Memo	: DSA-20P-10 US 120180	Humidity	: 55 %

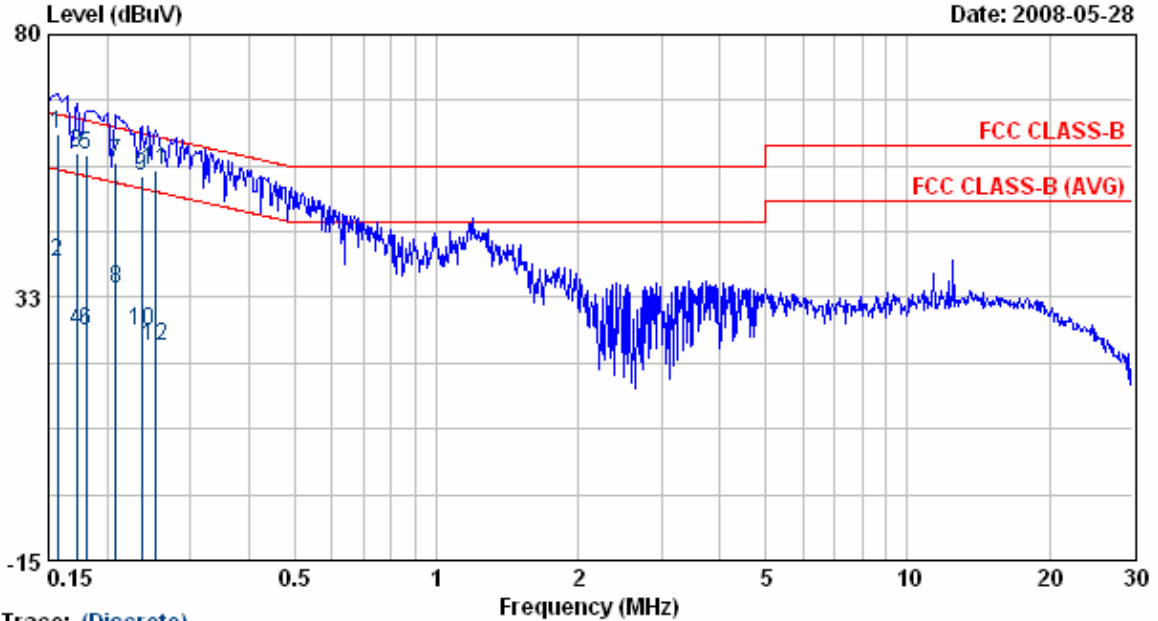

Trace: (Discrete)

Item	Freq	Read Value	Factor	Result	Limit	Margin	Remark
	MHz	dBuV	dB	dBuV	dBuV	dBuV	
1	0.16	61.94	0.09	62.03	65.65	-3.61	QP
2	0.16	38.85	0.09	38.94	55.65	-16.70	AVERAGE
3	0.17	58.58	0.09	58.67	64.86	-6.19	QP
4	0.17	26.44	0.09	26.53	54.86	-28.32	AVERAGE
5	0.18	58.14	0.09	58.23	64.46	-6.23	QP
6	0.18	26.42	0.09	26.51	54.46	-27.95	AVERAGE
7	0.21	56.77	0.09	56.86	63.27	-6.41	QP
8	0.21	33.79	0.09	33.88	53.27	-19.39	AVERAGE
9	0.24	54.51	0.09	54.60	62.22	-7.61	QP
10	0.24	26.53	0.09	26.63	52.22	-25.59	AVERAGE
11	0.25	55.44	0.09	55.53	61.69	-6.15	QP
12	0.25	23.63	0.09	23.72	51.69	-27.97	AVERAGE

Remarks:

1. Level = Read Level + Factor
2. Factor = LISN(ISN) Factor + Cable Loss
3. According to technical experiences, all spurious emission of 802.11MIMO mode at channel 1,6,11 are almost the same below 1GHz, so that the channel 1 was chosen as representative in final test.
4. The data is worse case.

Power	: AC 120V	Pol/Phase	: LINE
Test Mode 1	: 802.11n, HT40 CH3	Temperature	: 25 °C
Memo	: DSA-20P-10 US 120180	Humidity	: 55 %

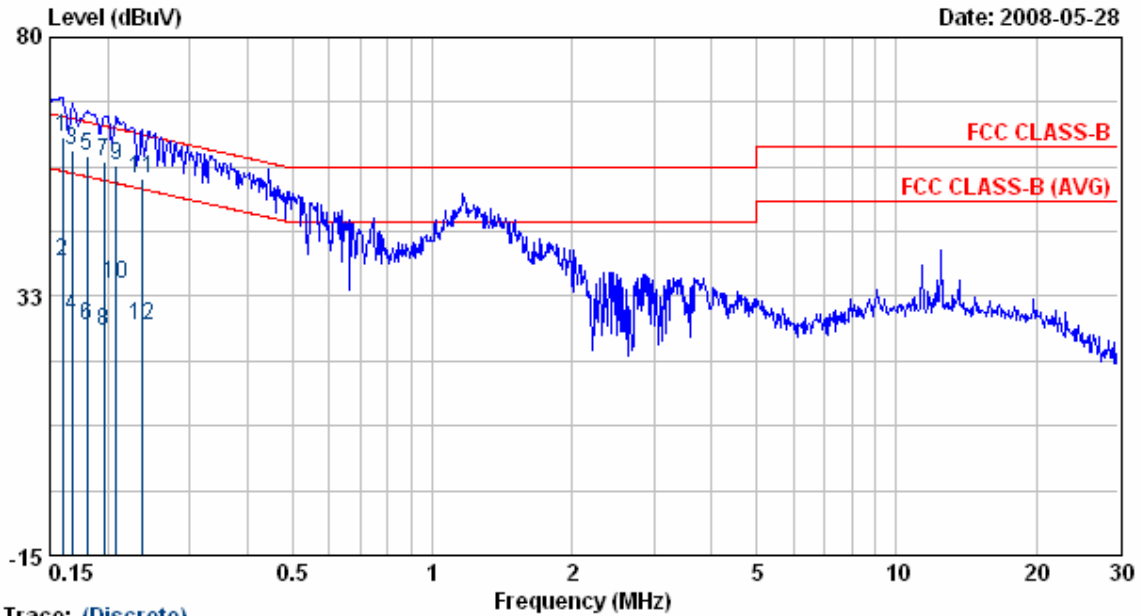

Trace: (Discrete)

Item	Freq	Read Value	Factor	Result	Limit	Margin	Remark
	MHz	dBuV	dB	dBuV	dBuV	dBuV	
1	0.16	61.48	0.10	61.58	65.47	-3.89	QP
2	0.16	38.64	0.10	38.75	55.47	-16.73	AVERAGE
3	0.17	59.13	0.10	59.23	65.08	-5.84	QP
4	0.17	28.76	0.10	28.86	55.08	-26.21	AVERAGE
5	0.18	58.24	0.10	58.34	64.46	-6.12	QP
6	0.18	26.94	0.10	27.04	54.46	-27.42	AVERAGE
7	0.20	56.98	0.10	57.09	63.76	-6.67	QP
8	0.20	25.90	0.10	26.00	53.76	-27.75	AVERAGE
9	0.21	56.50	0.11	56.61	63.27	-6.66	QP
10	0.21	34.50	0.11	34.61	53.27	-18.66	AVERAGE
11	0.24	54.11	0.11	54.22	62.22	-8.00	QP
12	0.24	26.89	0.11	27.00	52.22	-25.22	AVERAGE

Remarks:

1. Level = Read Level + Factor
2. Factor = LISN(ISN) Factor + Cable Loss
3. According to technical experiences, all spurious emission of 802.11MIMO mode at channel 3,6,9 are almost the same below 1GHz, so that the channel 3 was chosen as representative in final test.
4. The data is worse case.

Power	: AC 120V	Pol/Phase	: NEUTRAL
Test Mode 1	: 802.11n, HT40 CH3	Temperature	: 25 °C
Memo	: DSA-20P-10 US 120180	Humidity	: 55 %

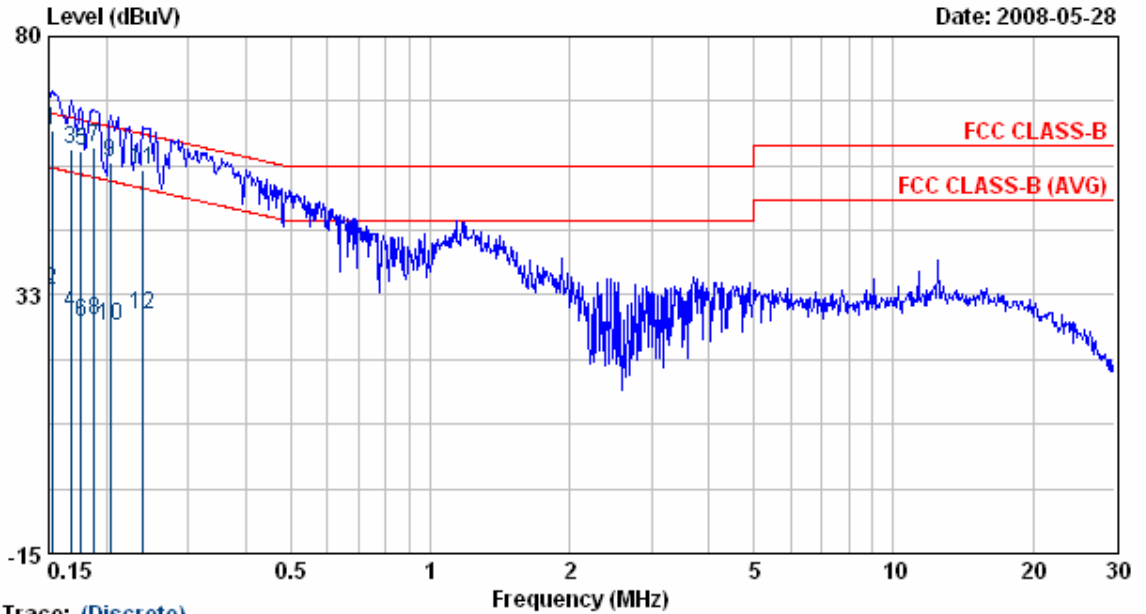

Trace: (Discrete)

Item	Freq	Read Value	Factor	Result	Limit	Margin	Remark
	MHz	dBuV	dB	dBuV	dBuV	dBuV	
1	0.15	62.70	0.09	62.79	65.87	-3.08	QP
2	0.15	33.44	0.09	33.53	55.87	-22.34	AVERAGE
3	0.17	59.05	0.09	59.14	65.08	-5.94	QP
4	0.17	29.06	0.09	29.15	55.08	-25.93	AVERAGE
5	0.18	58.92	0.09	59.01	64.68	-5.67	QP
6	0.18	27.26	0.09	27.35	54.68	-27.33	AVERAGE
7	0.19	59.44	0.09	59.53	64.11	-4.58	QP
8	0.19	27.80	0.09	27.89	54.11	-26.22	AVERAGE
9	0.20	56.67	0.09	56.76	63.45	-6.69	QP
10	0.20	26.75	0.09	26.84	53.45	-26.61	AVERAGE
11	0.24	55.52	0.09	55.61	62.08	-6.47	QP
12	0.24	28.92	0.09	29.01	52.08	-23.07	AVERAGE

Remarks:

1. Level = Read Level + Factor
2. Factor = LISN(ISN) Factor + Cable Loss
3. According to technical experiences, all spurious emission of 802.11MIMO mode at channel 3,6,9 are almost the same below 1GHz, so that the channel 3 was chosen as representative in final test.
4. The data is worse case.

Power	: AC 120V	Pol/Phase	: LINE
Test Mode 2	: 802.11g CH1	Temperature	: 25 °C
Memo	: MU18-2120150-A1	Humidity	: 55 %

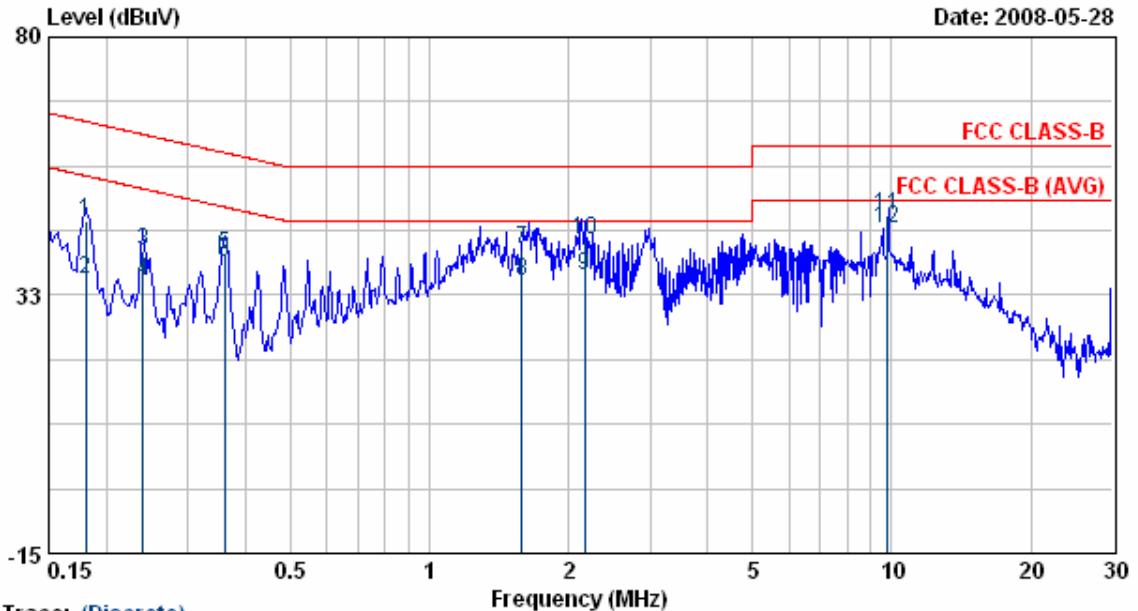

Trace: (Discrete)

Item	Freq	Read Value	Factor	Result	Limit	Margin	Remark
	MHz	dBuV	dB	dBuV	dBuV	dBuV	
1	0.18	45.98	0.10	46.08	64.46	-18.38	QP
2	0.18	35.45	0.10	35.55	72.46	-36.91	AVERAGE
3	0.24	40.61	0.11	40.72	62.08	-21.36	QP
4	0.24	34.95	0.11	35.06	70.08	-35.03	AVERAGE
5	0.36	39.79	0.11	39.90	58.74	-18.84	QP
6	0.36	38.49	0.11	38.60	66.74	-28.13	AVERAGE
7	1.58	40.92	0.18	41.10	56.00	-14.90	QP
8	1.58	34.97	0.18	35.15	64.00	-28.85	AVERAGE
9	2.16	36.04	0.20	36.24	64.00	-27.76	AVERAGE
10	2.16	42.34	0.20	42.55	56.00	-13.45	QP
11	9.81	46.93	0.34	47.26	60.00	-12.74	QP
12	9.81	44.55	0.34	44.89	64.00	-19.11	AVERAGE

- Remarks:
- Level = Read Level + Factor
 - Factor = LISN (ISN) Factor + Cable Loss
 - All emission below 1GHz at 802.11g mode are all the same, so the 802.11g mode chosen as representative in final test.
 - According to technical experiences, all spurious emission of 802.11g mode at channel 1, 6, 11 are almost the same below 1GHz, so that the channel 1 was chosen as representative in final test.
 - The data is worse case.

Power	: AC 120V	Pol/Phase	: NEUTRAL
Test Mode 2	: 802.11g CH1	Temperature	: 25 °C
Memo	: MU18-2120150-A1	Humidity	: 55 %

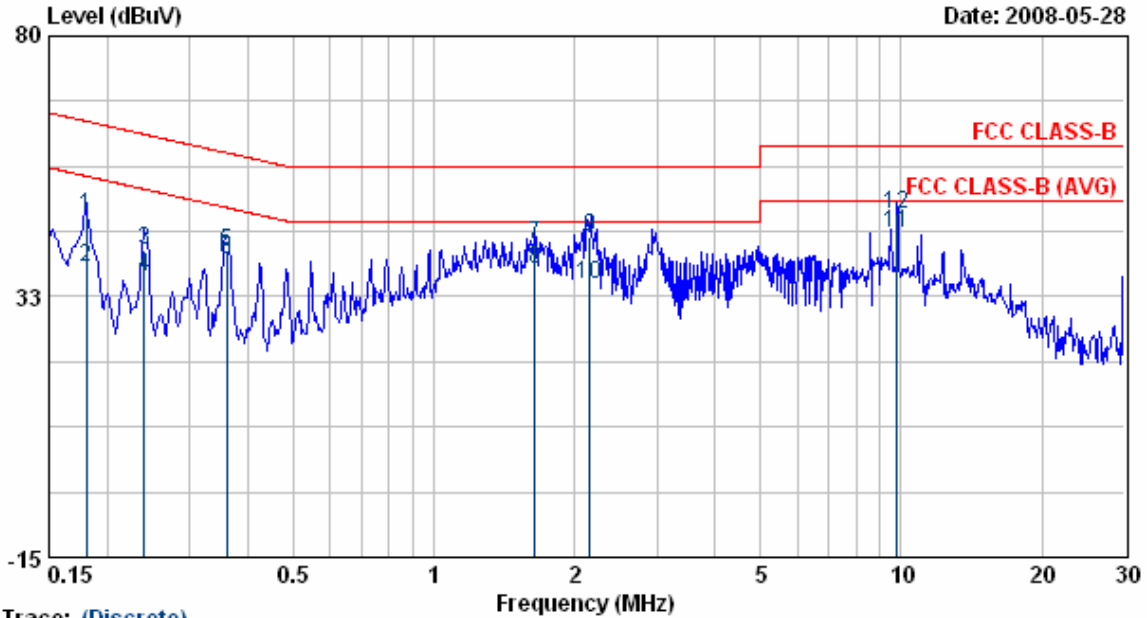

Trace: (Discrete)

Item	Freq	Read Value	Factor	Result	Limit	Margin	Remark
	MHz	dBuV	dB	dBuV	dBuV	dBuV	
1	0.18	47.16	0.09	47.25	64.46	-17.21	QP
2	0.18	37.77	0.09	37.86	72.46	-34.60	AVERAGE
3	0.24	40.71	0.09	40.80	62.08	-21.28	QP
4	0.24	36.06	0.09	36.15	70.08	-33.93	AVERAGE
5	0.36	40.58	0.10	40.68	58.74	-18.06	QP
6	0.36	39.21	0.10	39.31	66.74	-27.43	AVERAGE
7	1.64	41.91	0.18	42.09	56.00	-13.91	QP
8	1.64	37.32	0.18	37.50	64.00	-26.50	AVERAGE
9	2.16	43.25	0.20	43.45	56.00	-12.55	QP
10	2.16	34.69	0.20	34.89	64.00	-29.11	AVERAGE
11	9.80	43.73	0.38	44.10	64.00	-19.90	AVERAGE
12	9.80	47.28	0.38	47.66	60.00	-12.34	QP

- Remarks:
1. Level = Read Level + Factor
 2. Factor = LISN(ISN) Factor + Cable Loss
 3. All emission below 1GHz at 802.11b/g mode are all the same,so the 802.11g mode chosen as representative in final test.
 4. According to technical experiences,all spurious emission of 802.11g mode at channel 1,6,11 are almost the same below 1GHz,so that the channel 1 was chosen as representative in final test.
 5. The data is worse case.

Power	: AC 120V	Pol/Phase	: LINE
Test Mode 2	: 802.11n, HT20 CH1	Temperature	: 25 °C
Memo	: MU18-2120150-A1	Humidity	: 55 %

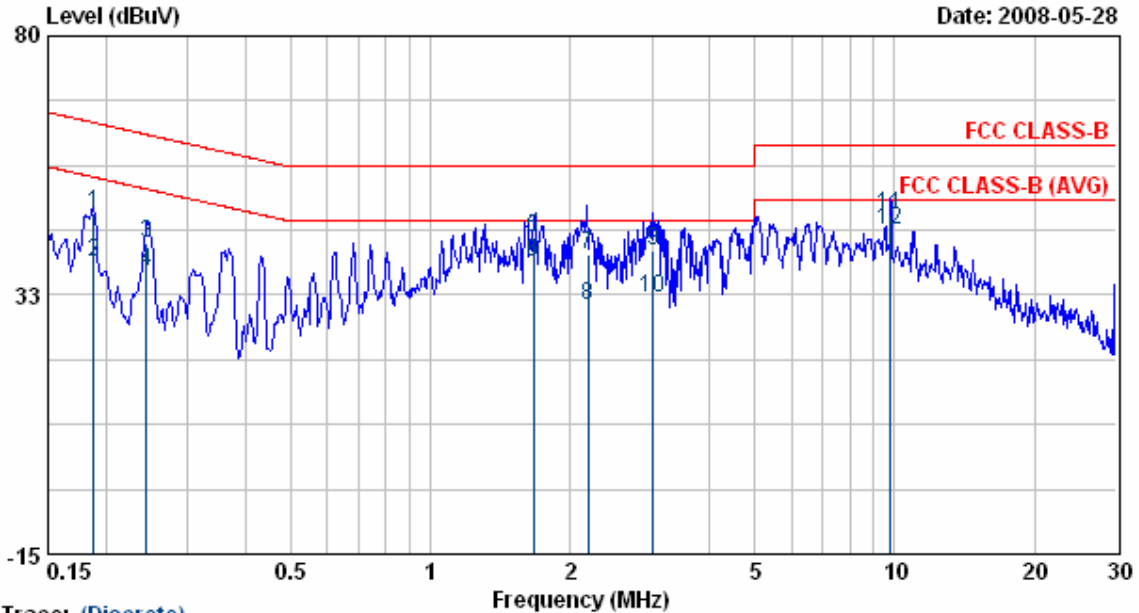

Trace: (Discrete)

Item	Freq	Read Value	Factor	Result	Limit	Margin	Remark
	MHz	dBuV	dB	dBuV	dBuV	dBuV	
1	0.19	47.56	0.10	47.66	64.11	-16.45	QP
2	0.19	38.38	0.10	38.48	54.11	-15.63	AVERAGE
3	0.24	42.05	0.11	42.16	61.95	-19.79	QP
4	0.24	36.86	0.11	36.97	51.95	-14.98	AVERAGE
5	1.67	42.76	0.18	42.95	56.00	-13.05	QP
6	1.67	38.44	0.18	38.62	46.00	-7.38	AVERAGE
7	2.19	39.80	0.20	40.00	56.00	-16.00	QP
8	2.19	30.48	0.20	30.69	46.00	-15.31	AVERAGE
9	3.02	40.45	0.22	40.67	56.00	-15.33	QP
10	3.02	31.80	0.22	32.02	46.00	-13.98	AVERAGE
11	9.79	46.94	0.34	47.28	60.00	-12.72	QP
12	9.79	43.94	0.34	44.28	50.00	-5.72	AVERAGE

Remarks:

1. Level = Read Level + Factor
2. Factor = LISN(ISN) Factor + Cable Loss
3. According to technical experiences, all spurious emission of 802.11MIMO mode at channel 1,6,11 are almost the same below 1GHz, so that the channel 1 was chosen as representative in final test.
4. The data is worse case.

Power	: AC 120V	Pol/Phase	: NEUTRAL
Test Mode 2	: 802.11n, HT20 CH1	Temperature	: 25 °C
Memo	: MU18-2120150-A1	Humidity	: 55 %

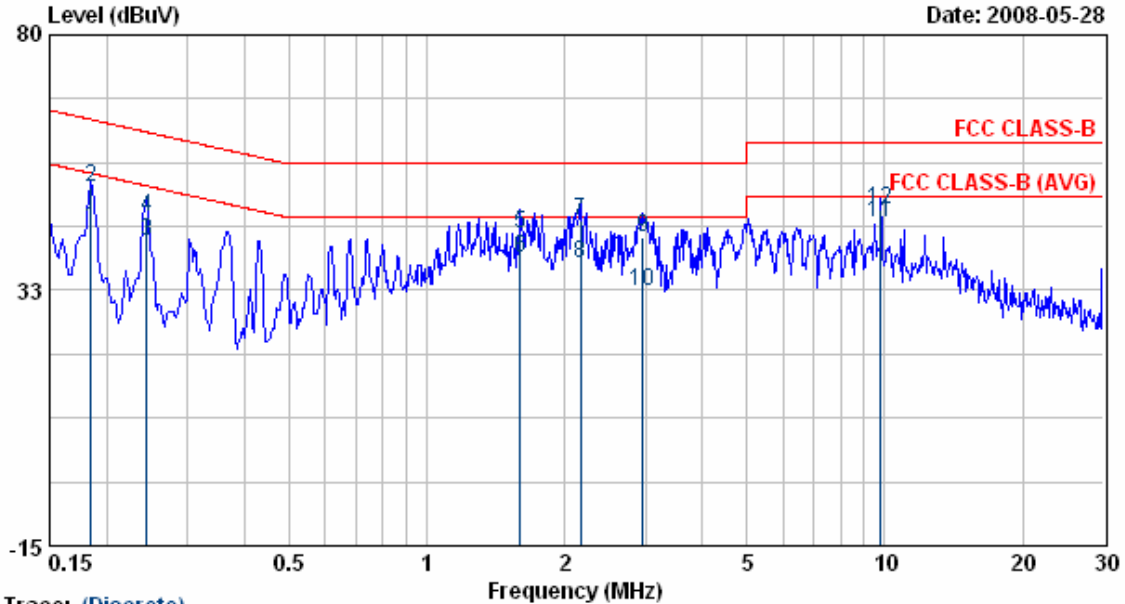

Trace: (Discrete)

Item	Freq	Read Value	Factor	Result	Limit	Margin	Remark
	MHz	dBuV	dB	dBuV	dBuV	dBuV	
1	0.18	43.88	0.09	43.97	54.28	-10.32	AVERAGE
2	0.18	51.49	0.09	51.58	64.28	-12.70	QP
3	0.24	41.58	0.09	41.67	51.95	-10.28	AVERAGE
4	0.24	46.22	0.09	46.31	61.95	-15.64	QP
5	1.60	42.90	0.17	43.07	56.00	-12.93	QP
6	1.60	38.32	0.17	38.49	46.00	-7.51	AVERAGE
7	2.16	45.18	0.20	45.38	56.00	-10.62	QP
8	2.16	37.28	0.20	37.47	46.00	-8.53	AVERAGE
9	2.96	42.18	0.22	42.40	56.00	-13.60	QP
10	2.96	32.18	0.22	32.40	46.00	-13.60	AVERAGE
11	9.79	44.58	0.38	44.95	50.00	-5.05	AVERAGE
12	9.79	47.23	0.38	47.61	60.00	-12.39	QP

Remarks:

1. Level = Read Level + Factor
2. Factor = LISN(ISN) Factor + Cable Loss
3. According to technical experiences, all spurious emission of 802.11MIMO mode at channel 1,6,11 are almost the same below 1GHz, so that the channel 1 was chosen as representative in final test.
4. The data is worse case.

Power	: AC 120V	Pol/Phase	: LINE
Test Mode 2	: 802.11n, HT40 CH3	Temperature	: 25 °C
Memo	: MU18-2120150-A1	Humidity	: 55 %

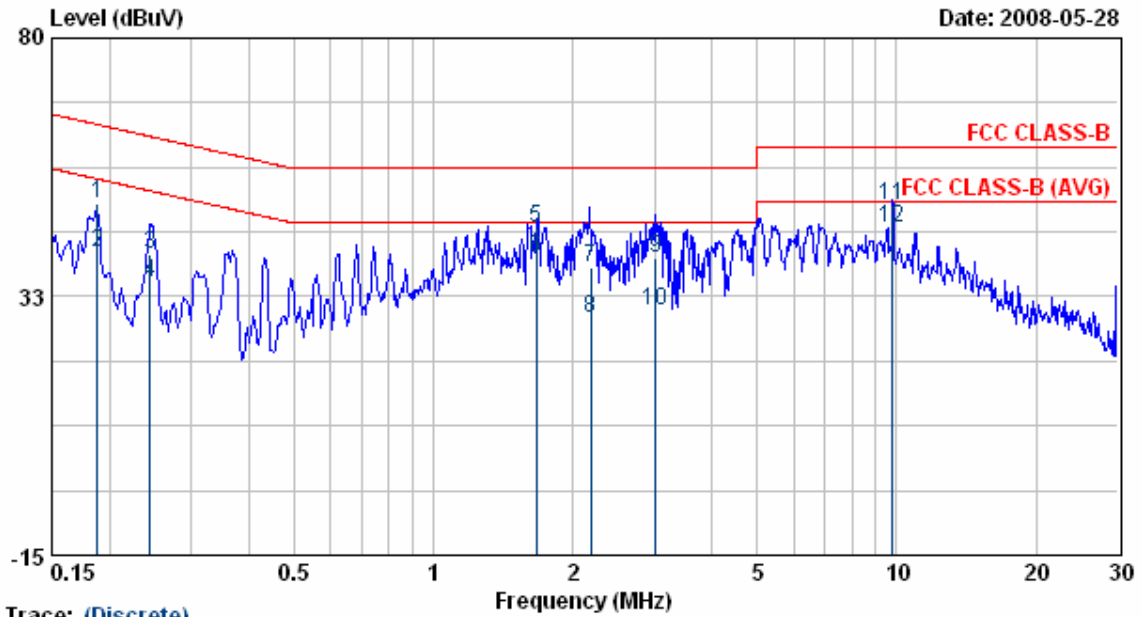

Trace: (Discrete)

Item	Freq	Read Value	Factor	Result	Limit	Margin	Remark
	MHz	dBuV	dB	dBuV	dBuV	dBuV	
1	0.19	49.56	0.10	49.66	64.11	-14.45	QP
2	0.19	40.38	0.10	40.48	54.11	-13.63	AVERAGE
3	0.24	40.05	0.11	40.16	61.95	-21.79	QP
4	0.24	34.86	0.11	34.97	51.95	-16.98	AVERAGE
5	1.67	44.76	0.18	44.95	56.00	-11.05	QP
6	1.67	39.44	0.18	39.62	46.00	-6.38	AVERAGE
7	2.19	37.80	0.20	38.00	56.00	-18.00	QP
8	2.19	28.48	0.20	28.69	46.00	-17.31	AVERAGE
9	3.02	39.45	0.22	39.67	56.00	-16.33	QP
10	3.02	29.80	0.22	30.02	46.00	-15.98	AVERAGE
11	9.79	48.94	0.34	49.28	60.00	-10.72	QP
12	9.79	44.94	0.34	45.28	50.00	-4.72	AVERAGE

Remarks:

1. Level = Read Level + Factor
2. Factor = LISN(ISN) Factor + Cable Loss
3. According to technical experiences, all spurious emission of 802.11MIMO mode at channel 3,6,9 are almost the same below 1GHz, so that the channel 3 was chosen as representative in final test.
4. The data is worse case.

Power	: AC 120V	Pol/Phase	: NEUTRAL
Test Mode 2	: 802.11n, HT40 CH3	Temperature	: 25 °C
Memo	: MU18-2120150-A1	Humidity	: 55 %

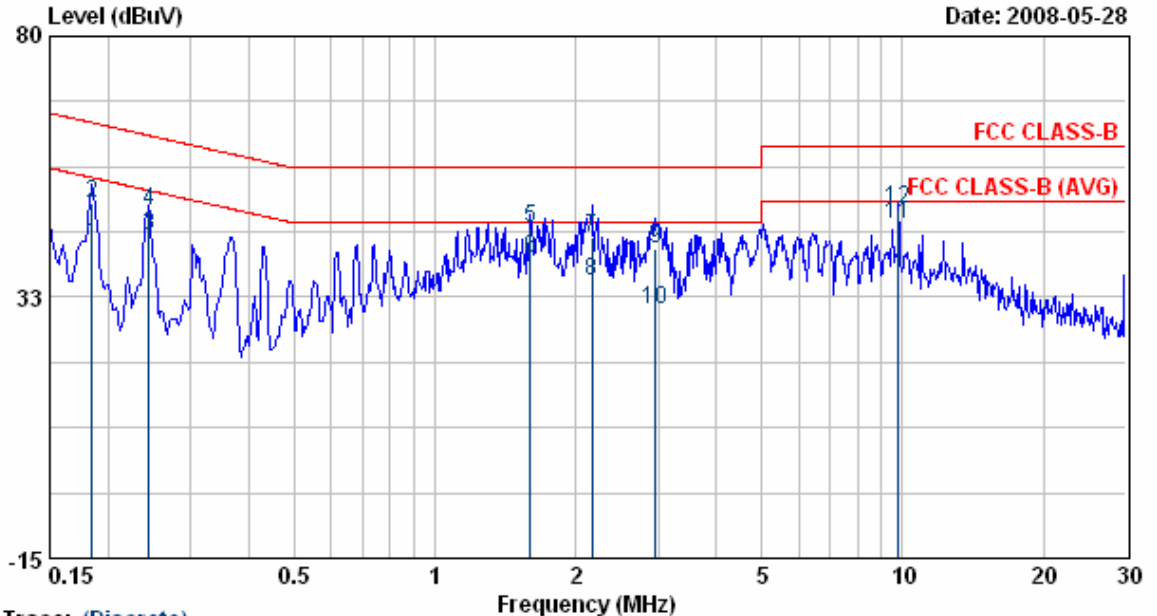

Trace: (Discrete)

Item	Freq	Read Value	Factor	Result	Limit	Margin	Remark
	MHz	dBuV	dB	dBuV	dBuV	dBuV	
1	0.18	41.88	0.09	41.97	54.28	-12.32	AVERAGE
2	0.18	49.49	0.09	49.58	64.28	-14.70	QP
3	0.24	43.58	0.09	43.67	51.95	-8.28	AVERAGE
4	0.24	48.22	0.09	48.31	61.95	-13.64	QP
5	1.60	44.90	0.17	45.07	56.00	-10.93	QP
6	1.60	39.32	0.17	39.49	46.00	-6.51	AVERAGE
7	2.16	43.18	0.20	43.38	56.00	-12.62	QP
8	2.16	35.28	0.20	35.47	46.00	-10.53	AVERAGE
9	2.96	41.18	0.22	41.40	56.00	-14.60	QP
10	2.96	30.18	0.22	30.40	46.00	-15.60	AVERAGE
11	9.79	45.58	0.38	45.95	50.00	-4.05	AVERAGE
12	9.79	48.23	0.38	48.61	60.00	-11.39	QP

Remarks:

1. Level = Read Level + Factor
2. Factor = LISN(ISN) Factor + Cable Loss
3. According to technical experiences, all spurious emission of 802.11MIMO mode at channel 3,6,9 are almost the same below 1GHz, so that the channel 3 was chosen as representative in final test.
4. The data is worse case.

Power	: AC 120V	Pol/Phase	: LINE
Test Mode 3	: 802.11g CH1	Temperature	: 25 °C
Memo	: MT12-Y120100-A1	Humidity	: 55 %

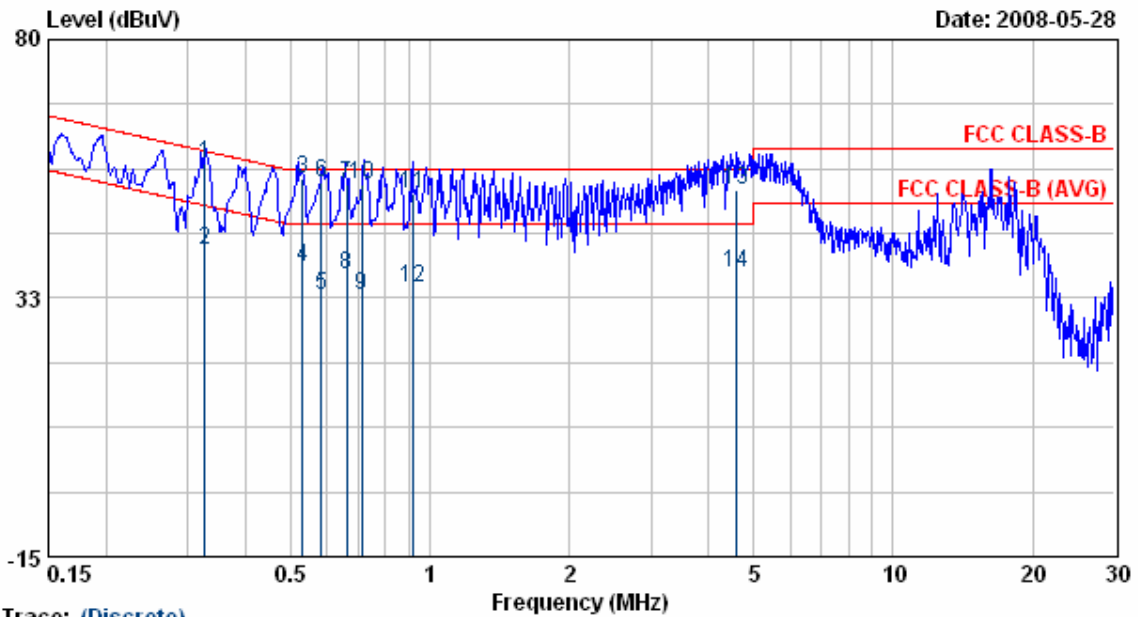

Trace: (Discrete)

Item	Freq	Read Value	Factor	Result	Limit	Margin	Remark
	MHz	dBuV	dB	dBuV	dBuV	dBuV	
1	0.33	57.08	0.11	57.19	59.52	-2.33	QP
2	0.33	41.35	0.11	41.47	49.52	-8.06	AVERAGE
3	0.53	54.31	0.12	54.43	56.00	-1.57	QP
4	0.53	38.13	0.12	38.25	46.00	-7.75	AVERAGE
5	0.58	33.00	0.12	33.12	46.00	-12.88	AVERAGE
6	0.58	53.45	0.12	53.57	56.00	-2.43	QP
7	0.66	53.32	0.13	53.44	56.00	-2.56	QP
8	0.66	36.85	0.13	36.97	46.00	-9.03	AVERAGE
9	0.71	32.74	0.13	32.87	46.00	-13.13	AVERAGE
10	0.71	53.43	0.13	53.56	56.00	-2.44	QP
11	0.92	51.68	0.14	51.82	56.00	-4.18	QP
12	0.92	34.13	0.14	34.26	46.00	-11.74	AVERAGE
13	4.57	52.17	0.25	52.41	56.00	-3.59	QP
14	4.57	37.03	0.25	37.27	46.00	-8.73	AVERAGE

- Remarks:
1. Level = Read Level + Factor
 2. Factor = LISN(ISN) Factor + Cable Loss
 3. All emission below 1GHz at 802.11b/g mode are all the same,so the 802.11g mode chosen as representative in final test.
 4. According to technical experiences,all spurious emission of 802.11g mode at channel 1,6,11 are almost the same below 1GHz,so that the channel 1 was chosen as representative in final test.
 5. The data is worse case.

Power	: AC 120V	Pol/Phase	: NEUTRAL
Test Mode 3	: 802.11g CH1	Temperature	: 25 °C
Memo	: MT12-Y120100-A1	Humidity	: 55 %

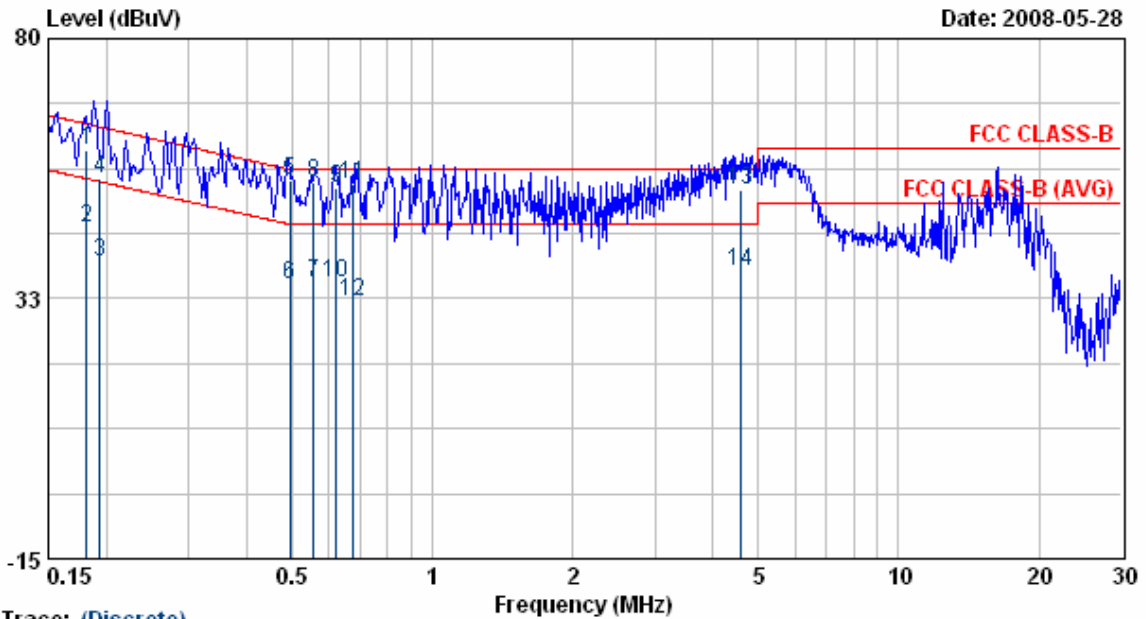

Trace: (Discrete)

Item	Freq	Read Value	Factor	Result	Limit	Margin	Remark
	MHz	dBuV	dB	dBuV	dBuV	dBuV	
1	0.18	59.65	0.09	59.74	64.43	-4.69	QP
2	0.18	45.26	0.09	45.35	54.43	-9.08	AVERAGE
3	0.19	39.31	0.09	39.40	53.89	-14.49	AVERAGE
4	0.19	54.26	0.09	54.35	63.89	-9.54	QP
5	0.49	54.09	0.11	54.20	56.08	-1.88	QP
6	0.49	35.03	0.11	35.14	46.08	-10.94	AVERAGE
7	0.56	35.45	0.11	35.57	46.08	-10.43	AVERAGE
8	0.56	53.76	0.11	53.87	56.00	-2.13	QP
9	0.62	52.67	0.12	52.79	56.00	-3.21	QP
10	0.62	35.16	0.12	35.28	46.00	-10.72	AVERAGE
11	0.68	53.12	0.12	53.24	56.00	-2.76	QP
12	0.68	31.95	0.12	32.08	46.00	-13.92	AVERAGE
13	4.57	52.22	0.27	52.49	56.00	-3.51	QP
14	4.57	37.29	0.27	37.56	46.00	-8.44	Average

- Remarks:
1. Level = Read Level + Factor
 2. Factor = LISN(ISN) Factor + Cable Loss
 3. All emission below 1GHz at 802.11g mode are all the same,so the 802.11g mode chosen as representative in final test.
 4. According to technical experiences,all spurious emission of 802.11g mode at channel 1,6,11 are almost the same below 1GHz,so that the channel 1 was chosen as representative in final test.
 5. The data is worse case.

Power	: AC 120V	Pol/Phase	: LINE
Test Mode 3	: 802.11n, HT20 CH1	Temperature	: 25 °C
Memo	: MT12-Y120100-A1	Humidity	: 55 %

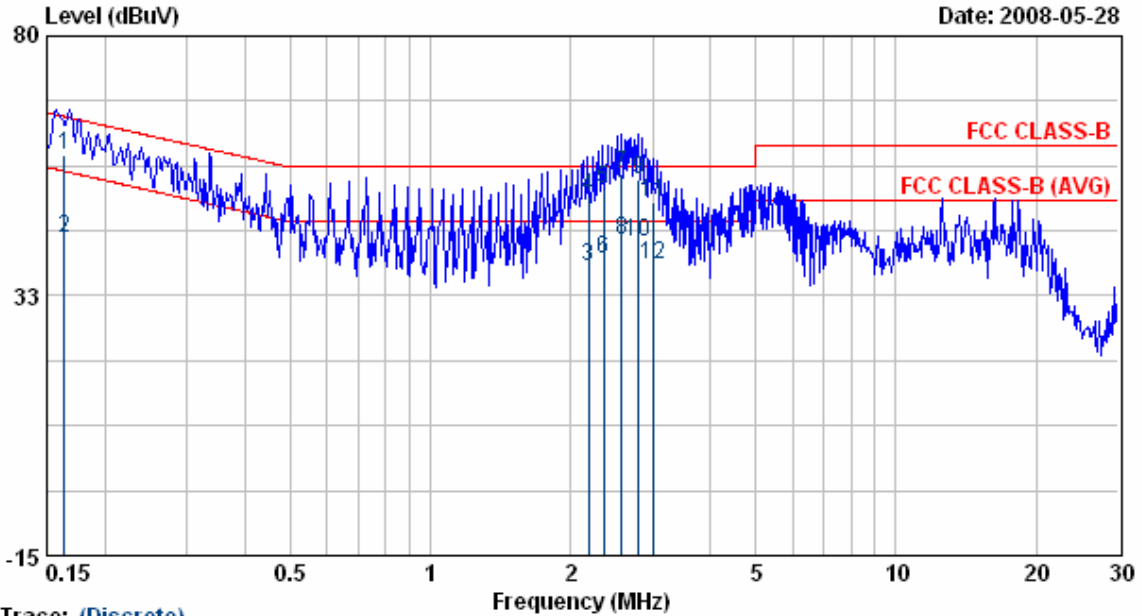

Trace: (Discrete)

Item	Freq	Read Value	Factor	Result	Limit	Margin	Remark
	MHz	dBuV	dB	dBuV	dBuV	dBuV	
1	0.16	58.02	0.10	58.13	65.30	-7.17	QP
2	0.16	42.78	0.10	42.88	55.30	-12.41	AVERAGE
3	2.19	37.66	0.20	37.86	46.00	-8.14	AVERAGE
4	2.19	50.54	0.20	50.74	56.00	-5.26	QP
5	2.35	51.97	0.21	52.18	56.00	-3.82	QP
6	2.35	39.03	0.21	39.24	46.00	-6.76	AVERAGE
7	2.58	54.58	0.21	54.79	56.00	-1.21	QP
8	2.58	42.47	0.21	42.68	46.00	-3.32	AVERAGE
9	2.80	53.39	0.21	53.61	56.00	-2.39	QP
10	2.80	42.13	0.21	42.34	46.00	-3.66	AVERAGE
11	3.01	49.50	0.22	49.72	56.00	-6.28	QP
12	3.01	37.87	0.22	38.09	46.00	-7.91	AVERAGE

Remarks:

1. Level = Read Level + Factor
2. Factor = LISN(ISN) Factor + Cable Loss
3. According to technical experiences, all spurious emission of 802.11MIMO mode at channel 1,6,11 are almost the same below 1GHz, so that the channel 1 was chosen as representative in final test.
4. The data is worse case.

Power	: AC 120V	Pol/Phase	: NEUTRAL
Test Mode 3	: 802.11n, HT20 CH1	Temperature	: 25 °C
Memo	: MT12-Y120100-A1	Humidity	: 55 %

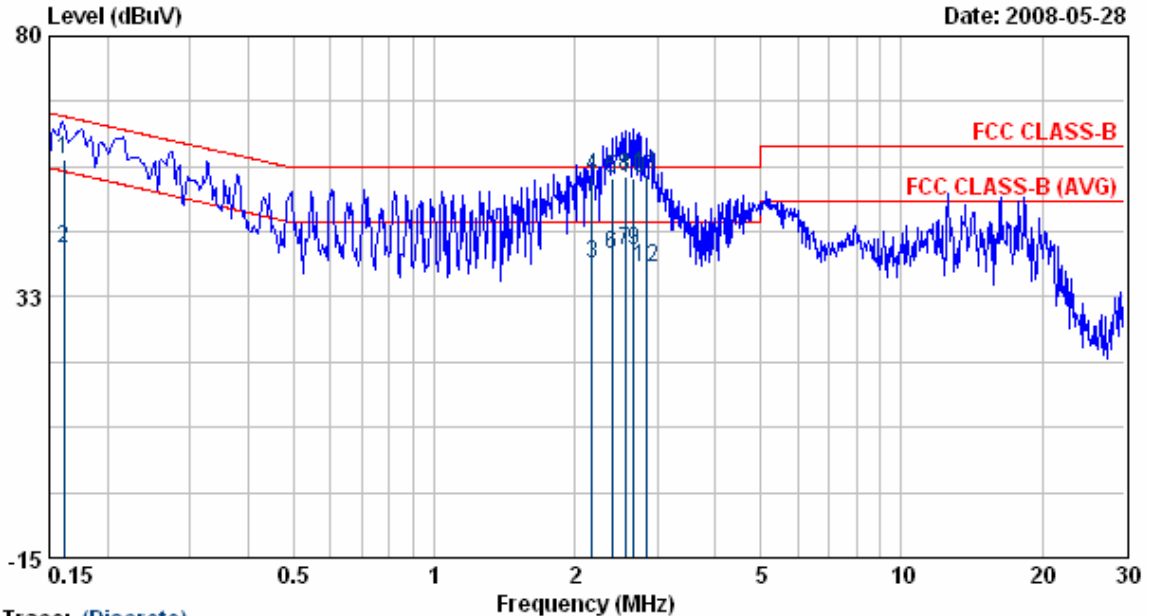

Trace: (Discrete)

Item	Freq	Read Value	Factor	Result	Limit	Margin	Remark
	MHz	dBuV	dB	dBuV	dBuV	dBuV	
1	0.16	57.45	0.09	57.54	65.39	-7.85	QP
2	0.16	41.13	0.09	41.22	55.39	-14.17	AVERAGE
3	2.18	38.30	0.20	38.50	46.00	-7.50	AVERAGE
4	2.18	54.07	0.20	54.27	56.00	-1.73	QP
5	2.40	54.01	0.21	54.22	56.00	-1.78	QP
6	2.40	39.94	0.21	40.15	46.00	-5.85	AVERAGE
7	2.57	40.79	0.21	41.00	46.00	-5.00	AVERAGE
8	2.57	54.31	0.21	54.52	56.00	-1.48	QP
9	2.68	40.92	0.22	41.13	46.00	-4.87	AVERAGE
10	2.68	53.85	0.22	54.07	56.00	-1.93	QP
11	2.84	54.70	0.22	54.92	56.00	-1.08	QP
12	2.84	37.75	0.22	37.97	46.00	-8.03	AVERAGE

Remarks:

1. Level = Read Level + Factor
2. Factor = LISN(ISN) Factor + Cable Loss
3. According to technical experiences, all spurious emission of 802.11MIMO mode at channel 1,6,11 are almost the same below 1GHz, so that the channel 1 was chosen as representative in final test.
4. The data is worse case.

Power	: AC 120V	Pol/Phase	: LINE
Test Mode 3	: 802.11n, HT40 CH3	Temperature	: 25 °C
Memo	: MT12-Y120100-A1	Humidity	: 55 %

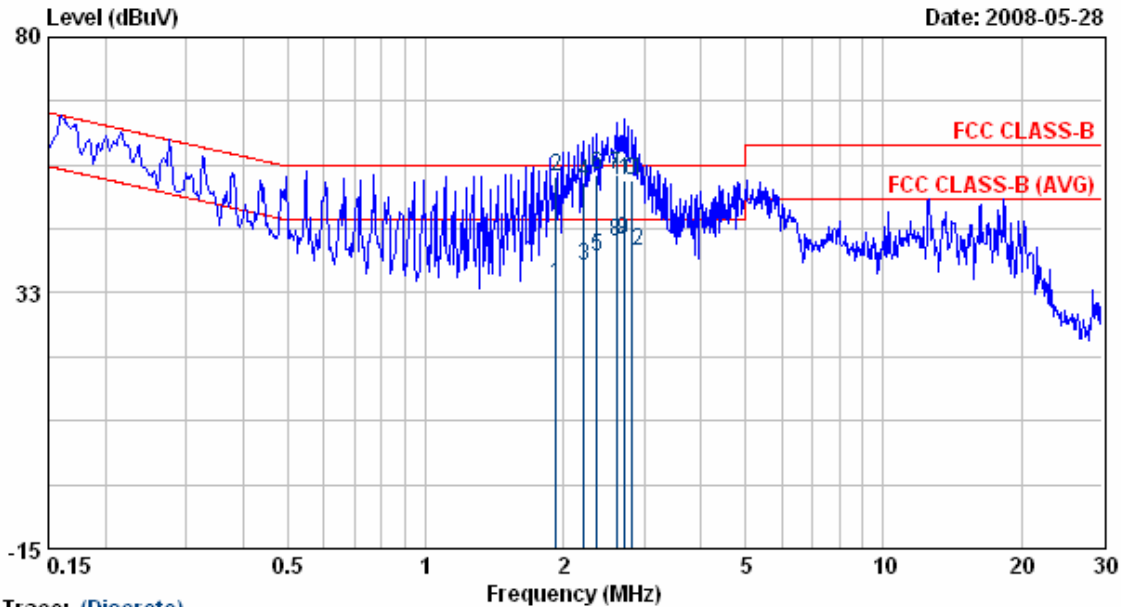

Trace: (Discrete)

Item	Freq	Read Value	Factor	Result	Limit	Margin	Remark
	MHz	dBuV	dB	dBuV	dBuV	dBuV	
1	1.93	33.86	0.20	34.05	46.00	-11.95	AVERAGE
2	1.93	53.80	0.20	53.99	56.00	-2.01	QP
3	2.22	37.29	0.20	37.49	46.00	-8.51	AVERAGE
4	2.22	52.84	0.20	53.04	56.00	-2.96	QP
5	2.37	38.95	0.21	39.15	46.00	-6.85	AVERAGE
6	2.37	54.33	0.21	54.54	56.00	-1.46	QP
7	2.61	54.21	0.21	54.42	56.00	-1.58	QP
8	2.61	41.78	0.21	41.99	46.00	-4.01	AVERAGE
9	2.71	42.24	0.21	42.45	46.00	-3.55	AVERAGE
10	2.71	53.26	0.21	53.47	56.00	-2.53	QP
11	2.82	53.01	0.21	53.23	56.00	-2.77	QP
12	2.82	40.09	0.21	40.31	46.00	-5.69	AVERAGE

Remarks:

1. Level = Read Level + Factor
2. Factor = LISN(ISN) Factor + Cable Loss
3. According to technical experiences, all spurious emission of 802.11MIMO mode at channel 3,6,9 are almost the same below 1GHz, so that the channel 3 was chosen as representative in final test.
4. The data is worse case.

Power	: AC 120V	Pol/Phase	: NEUTRAL
Test Mode 3	: 802.11n, HT40 CH3	Temperature	: 25 °C
Memo	: MT12-Y120100-A1	Humidity	: 55 %

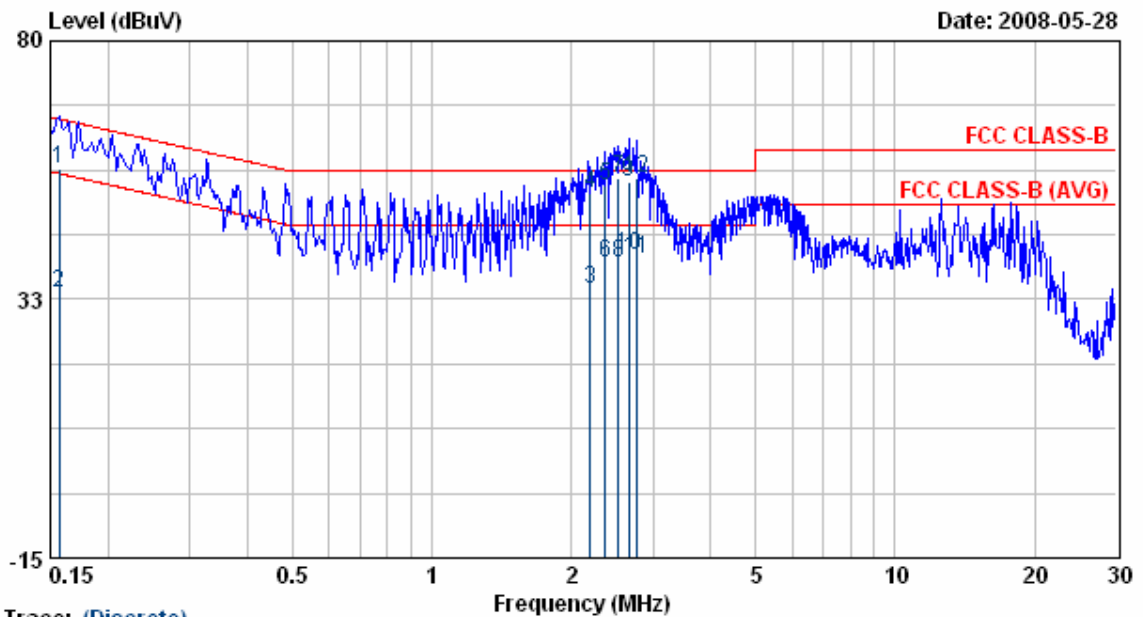

Trace: (Discrete)

Item	Freq	Read Value	Factor	Result	Limit	Margin	Remark
	MHz	dBuV	dB	dBuV	dBuV	dBuV	
1	0.16	56.44	0.09	56.53	65.64	-9.11	QP
2	0.16	33.76	0.09	33.85	55.64	-21.79	AVERAGE
3	2.20	34.25	0.20	34.45	46.00	-11.55	AVERAGE
4	2.20	51.95	0.20	52.15	56.00	-3.85	QP
5	2.37	53.33	0.20	53.53	56.00	-2.47	QP
6	2.37	38.89	0.20	39.10	46.00	-6.90	AVERAGE
7	2.53	54.62	0.21	54.83	56.00	-1.17	QP
8	2.53	39.13	0.21	39.34	46.00	-6.66	AVERAGE
9	2.66	53.79	0.21	54.00	56.00	-2.00	QP
10	2.66	40.33	0.21	40.54	46.00	-5.46	AVERAGE
11	2.77	39.64	0.22	39.86	46.00	-6.14	AVERAGE
12	2.77	54.42	0.22	54.64	56.00	-1.36	QP

Remarks:

1. Level = Read Level + Factor
2. Factor = LISN(ISN) Factor + Cable Loss
3. According to technical experiences, all spurious emission of 802.11MIMO mode at channel 3,6,9 are almost the same below 1GHz, so that the channel 3 was chosen as representative in final test.
4. The data is worse case.

Test engineer: Ben

5. Test of Radiated Emission

5.1 Test Limit

Radiated emissions from 30 MHz to 25 GHz were measured according to the methods defines in ANSI C63.4-2003. The EUT was placed, 0.8 meter above the ground plane, as shown in section 5.6.3. The interface cables and equipment positions were varied within limits of reasonable applications to determine the positions producing maximum radiated emissions

For unintentional device, according to § 15.109(a), except for Class A digital devices, the field strength of radiated emissions from unintentional radiators at a distance of 3 meters shall not exceed the following values:

Frequency (MHz)	Distance Meters	Radiated (μ V / M)	Radiated (dB μ V/ M)
30-88	3	100	40.0
88-216	3	150	43.5
216-960	3	200	46.0
Above 960	3	500	54.0

For unintentional device, according to CISPR PUB.22, for Class B digital devices, the general requirement of field strength of radiated emissions from intentional radiators at a distance of 10 meters shall not exceed the below table.

Frequency (MHz)	Distance Meters	Radiated (dB μ V/ M)
30-230	10	30
230-1000	10	37

5.2 Test Procedures

- The EUT was placed on a rotatable table top 0.8 meter above ground.
- The EUT was set 3 meters from the interference receiving antenna which was mounted on the top of a variable height antenna tower.
- The table was rotated 360 degrees to determine the position of the highest radiation.
- The antenna is a broadband antenna and its height is varied between one meter and four meters above ground to find the maximum value of the field strength both horizontal polarization and vertical polarization of the antenna are set to make the measurement.
- For each suspected emission the EUT was arranged to its worst case and then tune the antenna tower (from 1 M to 4 M) and turn table (from 0 degree to 360 degrees) to find the maximum reading.
- Set the test-receiver system to Peak or CISPR quasi-peak Detect Function and specified bandwidth with Maximum Hold Mode.
- If the emission level of the EUT in peak mode was 3 dB lower than the limit specified, then testing will be stopped and peak values of EUT will be reported, otherwise, the emissions which do not have 3 dB margin will be repeated one by one using the quasi-peak method and reported.
- For testing above 1GHz, the emission level of the EUT in peak mode was 20dB lower than average limit (that means the emission level in peak mode also complies with the limit in average mode), then testing will be stopped and peak values of EUT will be reported, otherwise, the emissions will be measured in average mode again and reported.
- “Cone of radiation” has been considered to be 3dB beamwidth of the measurement antenna.

5.3 Typical Test Setup

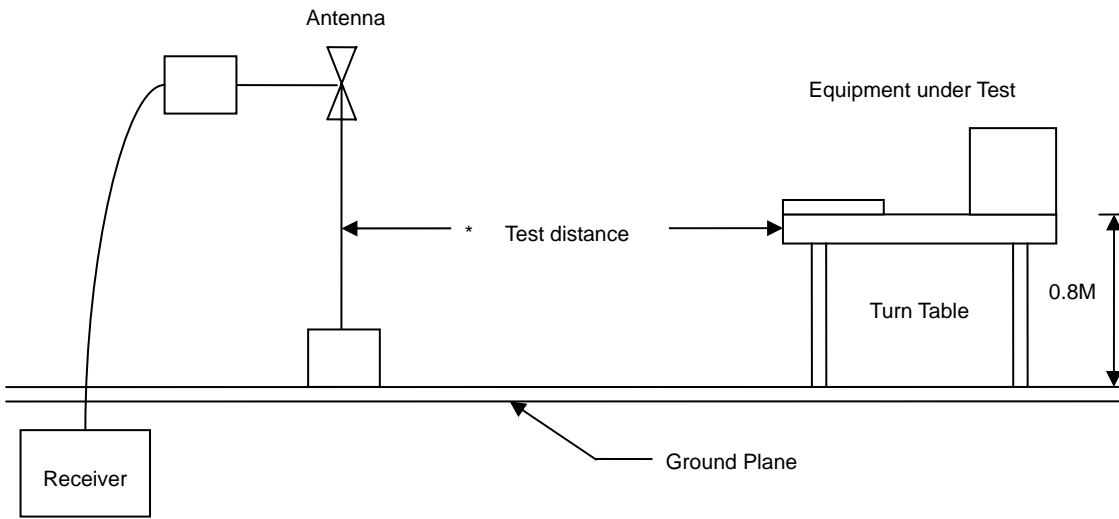

5.4 Measurement equipment

Instrument/Ancillary	Model No.	Manufacturer	Serial No.	Calibration Date	Valid Date
EMI Receiver	85460A	HP	3807A00454	2007/06/05	2008/06/04
Spectrum Analyzer	FSP40	R&S	10047	2008/02/22	2009/02/21
Horn Antenna	3115	EMCO	31589	2008/03/28	2009/03/27
Horn Antenna	3116	EMCO	31970	2008/04/08	2009/04/07
Bilog Antenna	CBL6112B	Schaffner	2840	2008/04/26	2009/04/25
Amplifier	8449B	Agilent	3008A01954	2008/01/24	2009/01/23
Amplifier	8447D	Agilent	2944A10531	2007/09/26	2008/09/25

5.5 Test Result and Data

Power	: AC 120V	Pol/Phase	: VERTICAL
Test Mode 1	: Transmit / Receive	Temperature	: 25 °C
Operation Channel	: 1	Humidity	: 65 %
Modulation Type	: 802.11g	Atmospheric Pressure	: 1020 hPa
Memo	: DSA-20P-10 US 120180	Rate	: 54Mbps

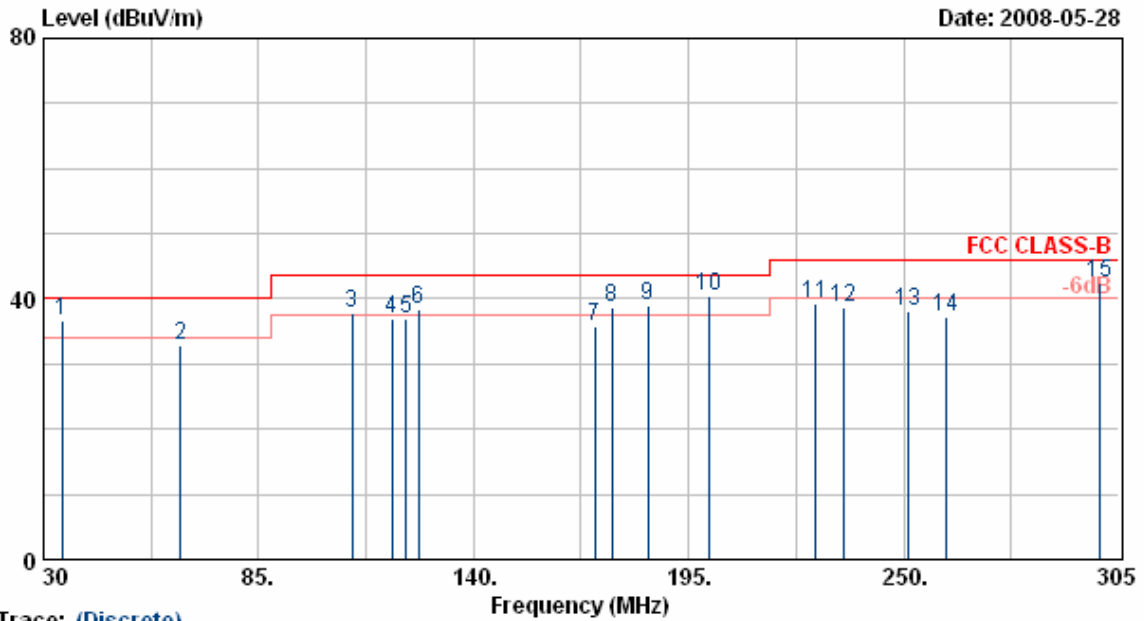

Trace: (Discrete)

Item	Freq	Read Value	Factor	Result	Limit	Margin	Remark	Ant Pos	Tab Pos
	MHz	dBuV/m	dB	dBuV/m	dBuV/m	dB		cm	Deg
1	34.67	44.74	-8.08	36.66	40.00	-3.34	QP	100	66
2	64.93	52.17	-19.28	32.89	40.00	-7.11	Peak	100	66
3	108.90	51.22	-13.48	37.74	43.50	-5.76	QP	100	105
4	119.10	50.43	-13.49	36.94	43.50	-6.56	Peak	100	22
5	122.68	50.53	-13.47	37.06	43.50	-6.44	Peak	100	95
6	125.98	52.03	-13.65	38.38	43.50	-5.12	QP	100	103
7	171.08	47.65	-11.81	35.84	43.50	-7.66	Peak	100	83
8	175.44	48.28	-9.71	38.57	43.50	-4.93	QP	100	83
9	184.55	48.36	-9.51	38.85	43.50	-4.65	QP	100	50
10	200.00	52.11	-11.75	40.36	43.50	-3.14	QP	100	50
11	227.18	51.57	-12.42	39.15	46.00	-6.85	Peak	100	50
12	234.60	48.56	-9.75	38.81	46.00	-7.19	Peak	100	95
13	251.10	50.42	-12.33	38.09	46.00	-7.91	Peak	100	144
14	260.73	46.84	-9.73	37.11	46.00	-8.89	Peak	100	122
15	300.00	51.95	-9.50	42.45	46.00	-3.55	QP	100	41

Notes:

1. Result = Read Value + Factor
2. Factor = Antenna Factor + Cable Loss - Amplifier
3. The resolution bandwidth of test receiver/spectrum analyzer is 120KHz and video bandwidth is 300kHz for Peak detection and Quasi-peak detection at frequency below 1GHz.
4. All emission below 1GHz at 802.11b/g mode are all the same, so the 802.11g mode chosen as representative in final test.
5. According to technical experiences, all spurious emission of 802.11g mode at channel 1,6,11 are almost the same below 1GHz, so that the channel 1 was chosen as representative in final test.
6. The data is worse case.

Power	: AC 120V	Pol/Phase	: VERTICAL
Test Mode 1	: Transmit / Receive	Temperature	: 25 °C
Operation Channel	: 1	Humidity	: 65 %
Modulation Type	: 802.11g	Atmospheric Pressure	: 1020 hPa
Memo	: DSA-20P-10 US 120180	Rate	: 54Mbps

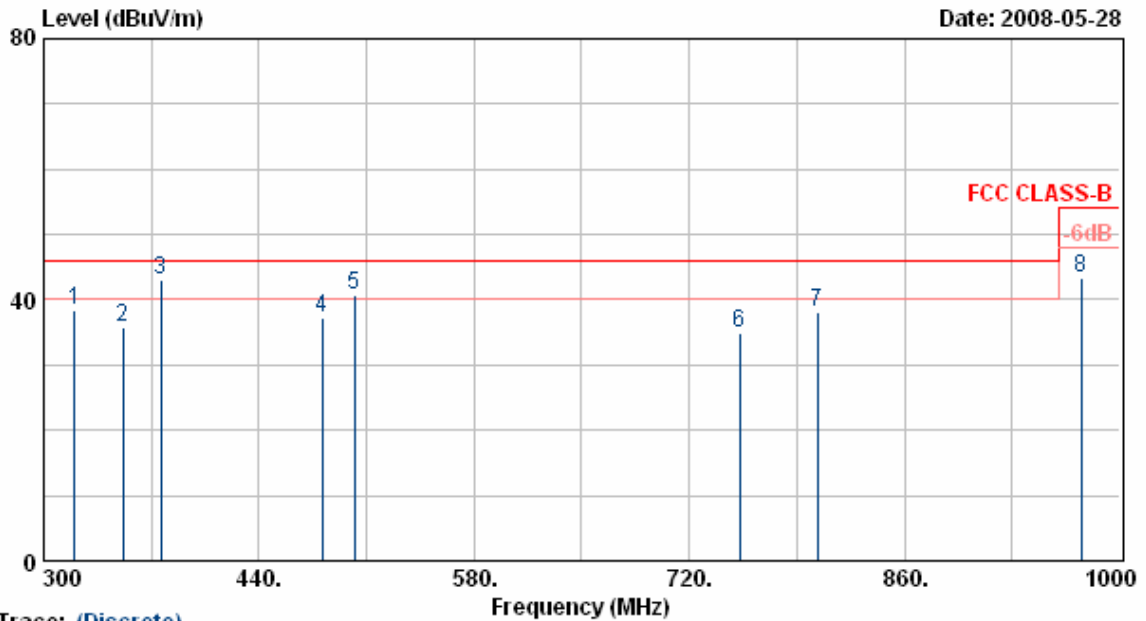

Trace: (Discrete)

Item	Freq MHz	Read Value dBuV/m	Factor dB	Result dBuV/m	Limit dBuV/m	Margin dB	Remark	Ant Pos cm	Tab Pos Deg
1	320.30	48.92	-10.38	38.54	46.00	-7.46	Peak	100	74
2	351.80	46.55	-10.65	35.90	46.00	-10.10	Peak	100	105
3	376.30	52.16	-9.17	42.99	46.00	-3.01	QP	100	105
4	481.30	41.82	-4.66	37.16	46.00	-8.84	Peak	100	144
5	502.30	45.55	-4.95	40.60	46.00	-5.40	QP	100	201
6	752.90	34.52	0.38	34.90	46.00	-11.10	Peak	100	201
7	803.30	40.87	-2.76	38.11	46.00	-7.89	Peak	100	74
8	974.80	40.00	3.45	43.45	54.00	-10.55	Peak	100	122

Notes:

1. Result = Read Value + Factor
2. Factor = Antenna Factor + Cable Loss - Amplifier
3. The resolution bandwidth of test receiver/spectrum analyzer is 120KHz and video bandwidth is 300kHz for Peak detection and Quasi-peak detection at frequency below 1GHz.
4. All emission below 1GHz at 802.11b/g mode are all the same,so the 802.11g mode chosen as representative in final test.
5. According to technical experiences,all spurious emission of 802.11g mode at channel 1,6,11 are almost the same below 1GHz,so that the channel 1 was chosen as representative in final test.
6. The data is worse case.

Power	: AC 120V	Pol/Phase	: HORIZONTAL
Test Mode 1	: Transmit / Receive	Temperature	: 25 °C
Operation Channel	: 1	Humidity	: 65 %
Modulation Type	: 802.11g	Atmospheric Pressure	: 1020 hPa
Memo	: DSA-20P-10 US 120180	Rate	: 54Mbps

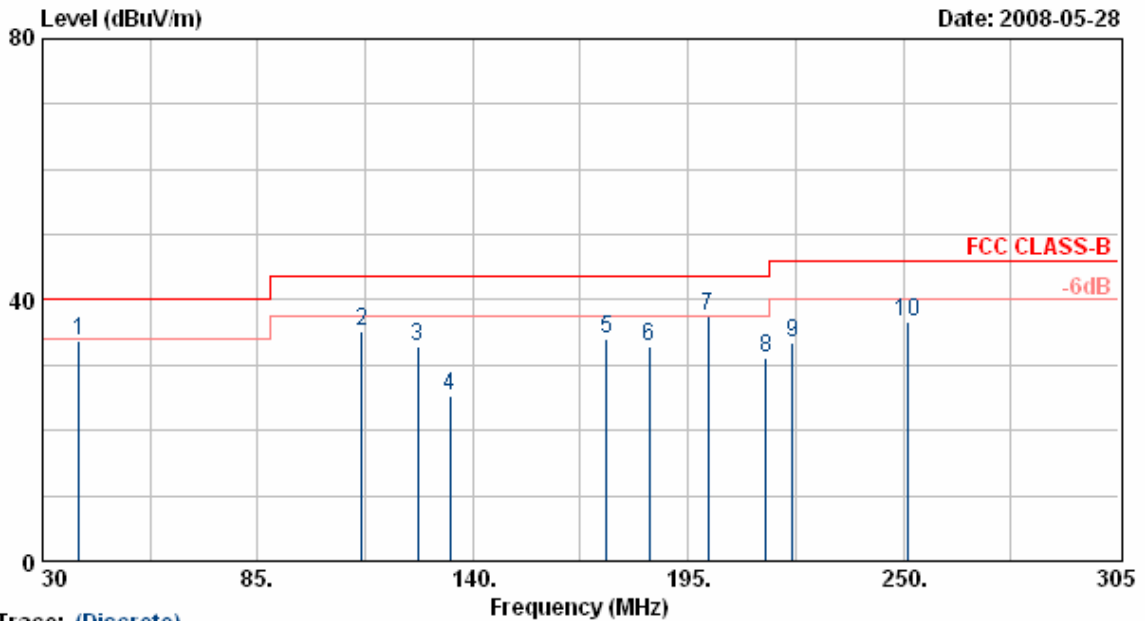

Trace: (Discrete)

Item	Freq	Read Value	Factor	Result	Limit	Margin	Remark	Ant Pos	Tab Pos
	MHz	dBuV/m	dB	dBuV/m	dBuV/m	dB		cm	Deg
1	39.35	48.55	-14.87	33.68	40.00	-6.32	Peak	200	45
2	111.70	54.56	-19.23	35.33	43.50	-8.17	Peak	200	147
3	125.98	52.52	-19.62	32.90	43.50	-10.60	Peak	200	152
4	134.23	44.78	-19.35	25.43	43.50	-18.07	Peak	200	222
5	174.10	51.98	-17.94	34.04	43.50	-9.46	Peak	200	188
6	185.10	50.82	-17.81	33.01	43.50	-10.49	Peak	200	28
7	200.01	51.96	-14.49	37.47	43.50	-6.03	Peak	200	222
8	215.00	49.58	-18.48	31.10	43.50	-12.40	Peak	200	87
9	221.70	51.52	-18.06	33.46	46.00	-12.54	Peak	200	157
10	251.10	53.83	-17.31	36.52	46.00	-9.48	Peak	200	255

Notes:

1. Result = Read Value + Factor
2. Factor = Antenna Factor + Cable Loss - Amplifier
3. The resolution bandwidth of test receiver/spectrum analyzer is 120KHz and video bandwidth is 300kHz for Peak detection and Quasi-peak detection at frequency below 1GHz.
4. All emission below 1GHz at 802.11b/g mode are all the same,so the 802.11g mode chosen as representative in final test.
5. According to technical experiences,all spurious emission of 802.11g mode at channel 1,6,11 are almost the same below 1GHz,so that the channel 1 was chosen as representative in final test.
6. The data is worse case.

Power	: AC 120V	Pol/Phase	: HORIZONTAL
Test Mode 1	: Transmit / Receive	Temperature	: 25 °C
Operation Channel	: 1	Humidity	: 65 %
Modulation Type	: 802.11g	Atmospheric Pressure	: 1020 hPa
Memo	: DSA-20P-10 US 120180	Rate	: 54Mbps

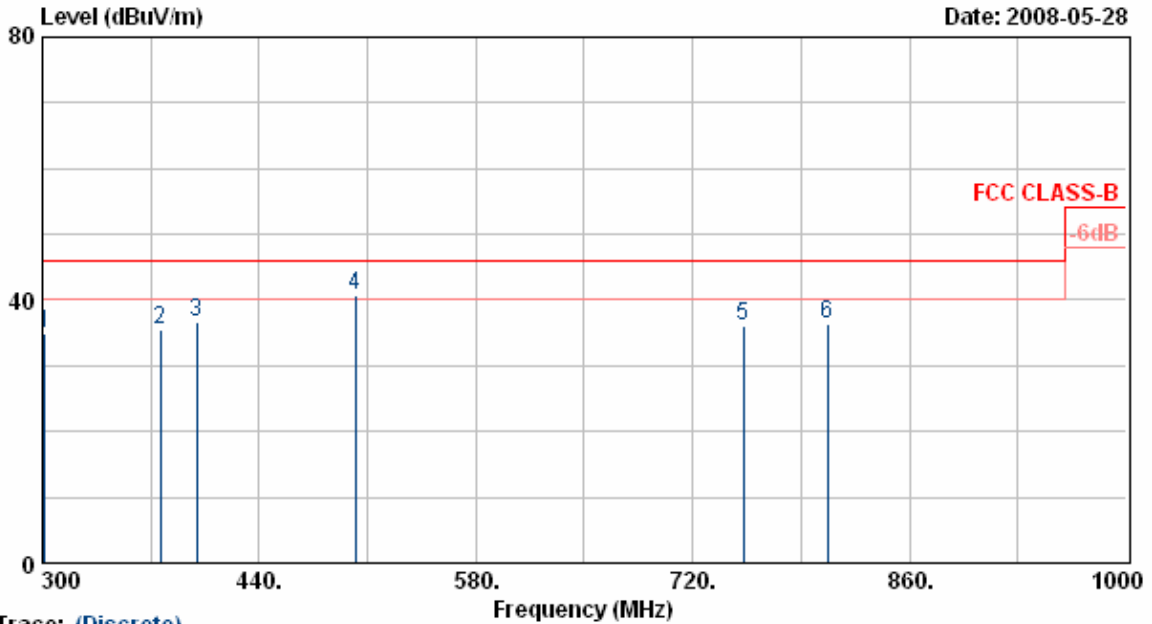

Trace: (Discrete)

Item	Freq	Read Value	Factor	Result	Limit	Margin	Remark	Ant Pos	Tab Pos
	MHz	dBuV/m	dB	dBuV/m	dBuV/m	dB		cm	Deg
1	301.40	49.15	-14.33	34.82	46.00	-11.18	Peak	200	333
2	376.30	46.28	-10.87	35.41	46.00	-10.59	Peak	200	99
3	399.40	47.66	-11.05	36.61	46.00	-9.39	Peak	200	232
4	502.30	45.68	-5.03	40.65	46.00	-5.35	QP	200	299
5	752.90	36.00	-0.03	35.97	46.00	-10.03	Peak	200	299
6	806.80	36.72	-0.43	36.29	46.00	-9.71	Peak	200	333

Notes:

1. Result = Read Value + Factor
2. Factor = Antenna Factor + Cable Loss - Amplifier
3. The resolution bandwidth of test receiver/spectrum analyzer is 120KHz and video bandwidth is 300kHz for Peak detection and Quasi-peak detection at frequency below 1GHz.
4. All emission below 1GHz at 802.11b/g mode are all the same,so the 802.11g mode chosen as representative in final test.
5. According to technical experiences,all spurious emission of 802.11g mode at channel 1,6,11 are almost the same below 1GHz,so that the channel 1 was chosen as representative in final test.
6. The data is worse case.

Power	: AC 120V	Pol/Phase	: VERTICAL
Test Mode 1	: Transmit / Receive	Temperature	: 25 °C
Operation Channel	: 1	Humidity	: 65 %
Modulation Type	: 802.11b	Atmospheric Pressure	: 1020 hPa
Memo	: DSA-20P-10 US 120180	Rate	: 11Mbps

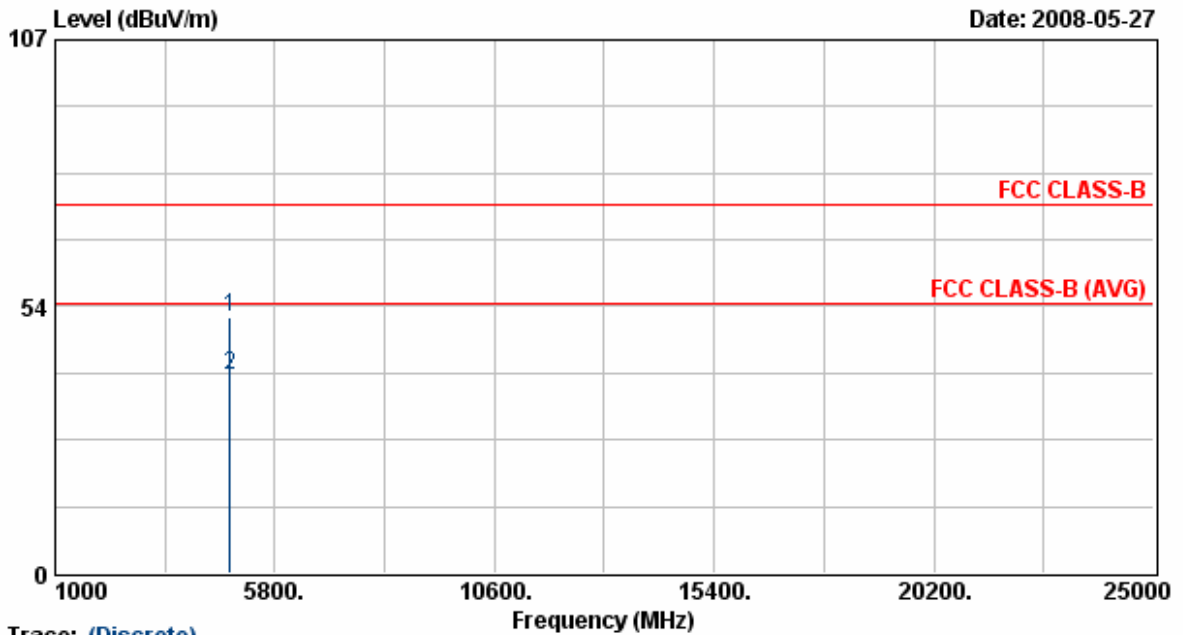

Trace: (Discrete)

Item	Freq	Read Value	Factor	Result	Limit	Margin	Remark	Ant Pos	Tab Pos
	MHz	dBuV/m	dB	dBuV/m	dBuV/m	dB		cm	Deg
1	4823.85	45.53	5.67	51.20	74.00	-22.80	Peak	100	144
2	4823.85	34.02	5.67	39.70	54.00	-14.30	Average	100	144

Notes:

1. Result = Read Value + Factor
2. Factor = Antenna Factor + Cable Loss - Amplifier
3. The resolution bandwidth of test receiver/spectrum analyzer is 120KHz and video bandwidth is 300kHz for Peak detection and Quasi-peak detection at frequency below 1GHz.
4. The resolution bandwidth of test receiver/spectrum analyzer is 1MHz and video bandwidth is 3MHz for Peak detection at frequency above 1GHz.
5. The resolution bandwidth of test receiver/spectrum analyzer is 1MHz and video bandwidth is 10Hz for Average detection at frequency above 1GHz.
6. The other emissions is too low to be measured.

Power	: AC 120V	Pol/Phase	: HORIZONTAL
Test Mode 1	: Transmit / Receive	Temperature	: 25 °C
Operation Channel	: 1	Humidity	: 65 %
Modulation Type	: 802.11b	Atmospheric Pressure	: 1020 hPa
Memo	: DSA-20P-10 US 120180	Rate	: 11Mbps

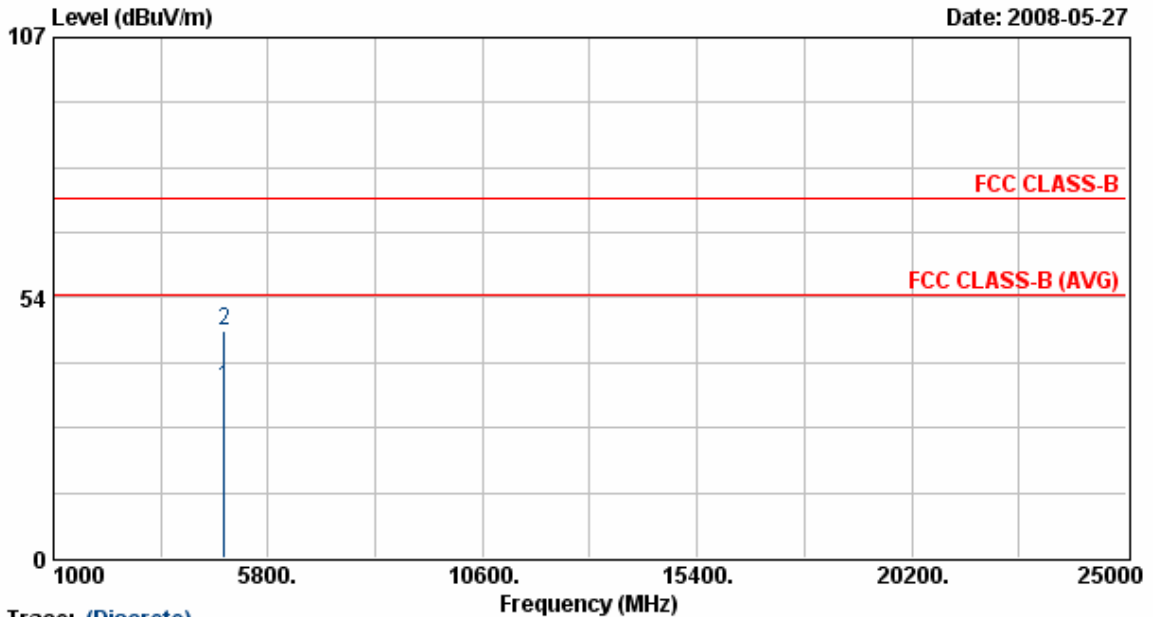

Trace: (Discrete)

Item	Freq	Read Value	Factor	Result	Limit	Margin	Remark	Ant Pos	Tab Pos
	MHz	dBuV/m	dB	dBuV/m	dBuV/m	dB		cm	Deg
1	4823.88	29.44	5.67	35.11	54.00	-18.89	Average	100	241
2	4823.88	41.21	5.67	46.88	74.00	-27.12	Peak	100	241

Notes:

1. Result = Read Value + Factor
2. Factor = Antenna Factor + Cable Loss - Amplifier
3. The resolution bandwidth of test receiver/spectrum analyzer is 120KHz and video bandwidth is 300kHz for Peak detection and Quasi-peak detection at frequency below 1GHz.
4. The resolution bandwidth of test receiver/spectrum analyzer is 1MHz and video bandwidth is 3MHz for Peak detection at frequency above 1GHz.
5. The resolution bandwidth of test receiver/spectrum analyzer is 1MHz and video bandwidth is 10Hz for Average detection at frequency above 1GHz.
6. The other emissions is too low to be measured.

Power	: AC 120V	Pol/Phase	: VERTICAL
Test Mode 1	: Transmit / Receive	Temperature	: 25 °C
Operation Channel	: 6	Humidity	: 65 %
Modulation Type	: 802.11b	Atmospheric Pressure	: 1020 hPa
Memo	: DSA-20P-10 US 120180	Rate	: 11Mbps

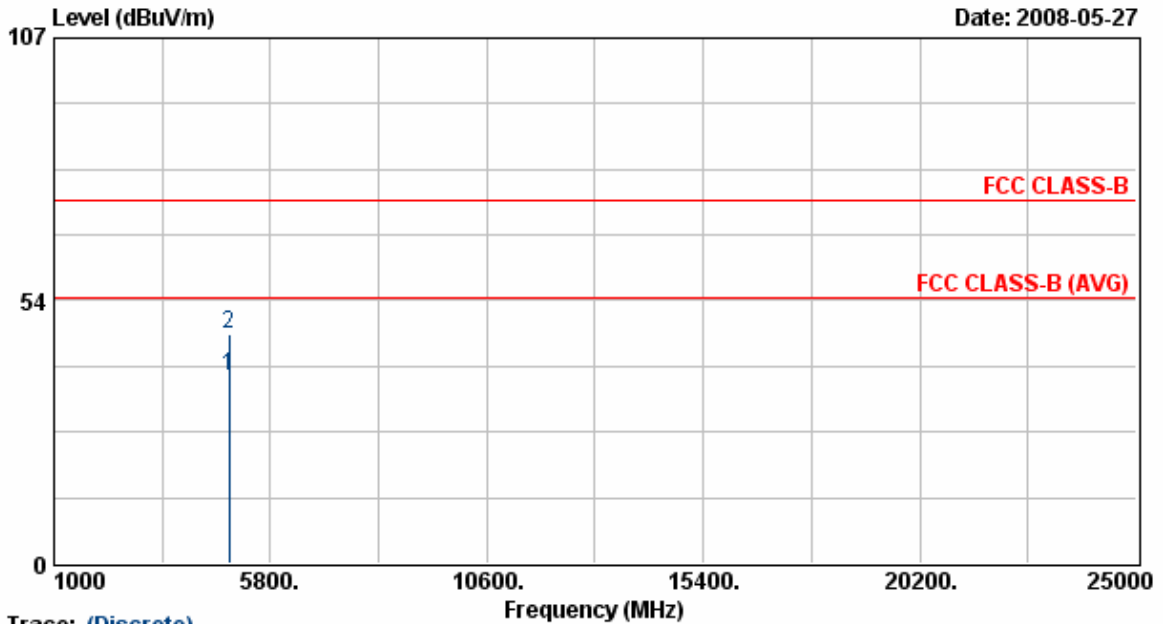

Trace: (Discrete)

Item	Freq	Read Value	Factor	Result	Limit	Margin	Remark	Ant Pos	Tab Pos
	MHz	dBuV/m	dB	dBuV/m	dBuV/m	dB		cm	Deg
1	4873.98	32.50	5.80	38.30	54.00	-15.70	Average	100	144
2	4873.98	41.00	5.80	46.80	74.00	-27.20	Peak	100	144

Notes:

1. Result = Read Value + Factor
2. Factor = Antenna Factor + Cable Loss - Amplifier
3. The resolution bandwidth of test receiver/spectrum analyzer is 120KHz and video bandwidth is 300kHz for Peak detection and Quasi-peak detection at frequency below 1GHz.
4. The resolution bandwidth of test receiver/spectrum analyzer is 1MHz and video bandwidth is 3MHz for Peak detection at frequency above 1GHz.
5. The resolution bandwidth of test receiver/spectrum analyzer is 1MHz and video bandwidth is 10Hz for Average detection at frequency above 1GHz.
6. The other emissions is too low to be measured.

Power	: AC 120V	Pol/Phase	: HORIZONTAL
Test Mode 1	: Transmit / Receive	Temperature	: 25 °C
Operation Channel	: 6	Humidity	: 65 %
Modulation Type	: 802.11b	Atmospheric Pressure	: 1020 hPa
Memo	: DSA-20P-10 US 120180	Rate	: 11Mbps

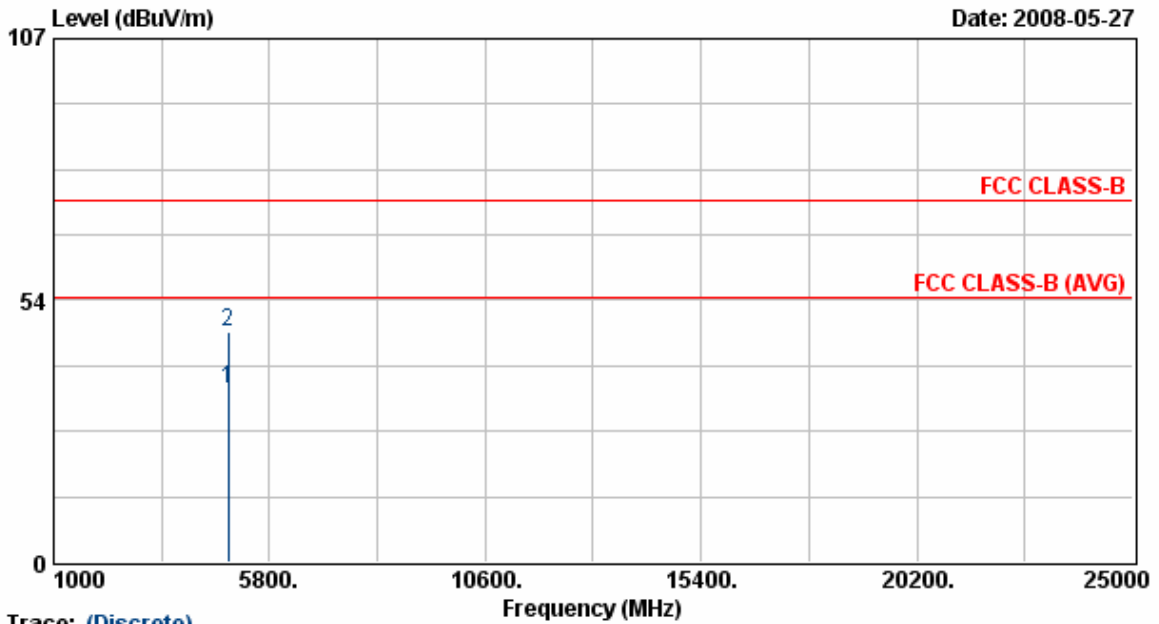

Trace: (Discrete)

Item	Freq	Read Value	Factor	Result	Limit	Margin	Remark	Ant Pos	Tab Pos
	MHz	dBuV/m	dB	dBuV/m	dBuV/m	dB		cm	Deg
1	4874.03	29.44	5.80	35.24	54.00	-18.76	Average	100	241
2	4874.03	41.38	5.80	47.18	74.00	-26.82	Peak	100	241

Notes:

1. Result = Read Value + Factor
2. Factor = Antenna Factor + Cable Loss - Amplifier
3. The resolution bandwidth of test receiver/spectrum analyzer is 120KHz and video bandwidth is 300kHz for Peak detection and Quasi-peak detection at frequency below 1GHz.
4. The resolution bandwidth of test receiver/spectrum analyzer is 1MHz and video bandwidth is 3MHz for Peak detection at frequency above 1GHz.
5. The resolution bandwidth of test receiver/spectrum analyzer is 1MHz and video bandwidth is 10Hz for Average detection at frequency above 1GHz.
6. The other emissions is too low to be measured.

Power	: AC 120V	Pol/Phase	: VERTICAL
Test Mode 1	: Transmit / Receive	Temperature	: 25 °C
Operation Channel	: 11	Humidity	: 65 %
Modulation Type	: 802.11b	Atmospheric Pressure	: 1020 hPa
Memo	: DSA-20P-10 US 120180	Rate	: 11Mbps

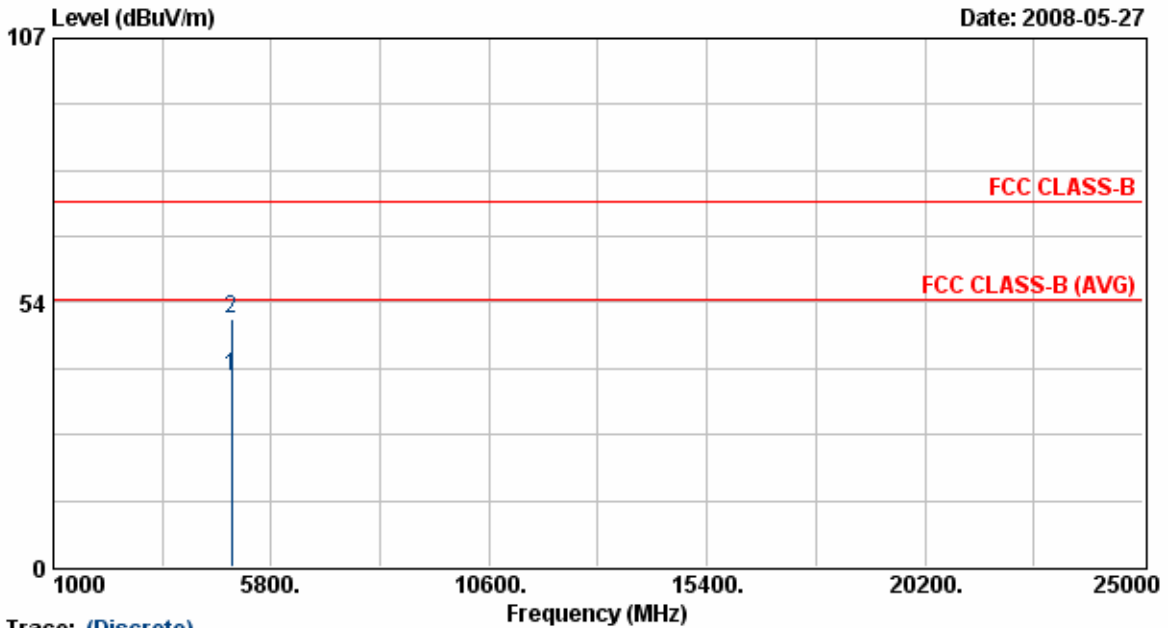

Trace: (Discrete)

Item	Freq	Read Value	Factor	Result	Limit	Margin	Remark	Ant Pos	Tab Pos
	MHz	dBuV/m	dB	dBuV/m	dBuV/m	dB		cm	Deg
1	4923.98	32.67	5.93	38.60	54.00	-15.40	Average	100	144
2	4923.98	44.41	5.93	50.34	74.00	-23.66	Peak	100	144

Notes:

1. Result = Read Value + Factor
2. Factor = Antenna Factor + Cable Loss - Amplifier
3. The resolution bandwidth of test receiver/spectrum analyzer is 120KHz and video bandwidth is 300kHz for Peak detection and Quasi-peak detection at frequency below 1GHz.
4. The resolution bandwidth of test receiver/spectrum analyzer is 1MHz and video bandwidth is 3MHz for Peak detection at frequency above 1GHz.
5. The resolution bandwidth of test receiver/spectrum analyzer is 1MHz and video bandwidth is 10Hz for Average detection at frequency above 1GHz.
6. The other emissions is too low to be measured.

Power	: AC 120V	Pol/Phase	: HORIZONTAL
Test Mode 1	: Transmit / Receive	Temperature	: 25 °C
Operation Channel	: 11	Humidity	: 65 %
Modulation Type	: 802.11b	Atmospheric Pressure	: 1020 hPa
Memo	: DSA-20P-10 US 120180	Rate	: 11Mbps

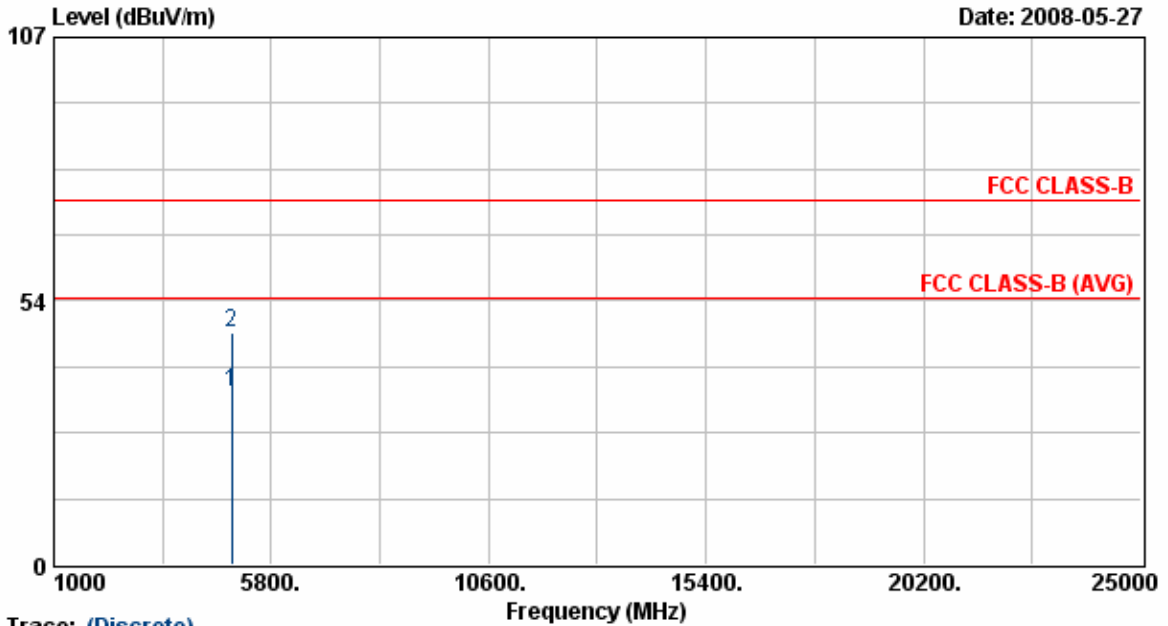

Trace: (Discrete)

Item	Freq	Read Value	Factor	Result	Limit	Margin	Remark	Ant Pos	Tab Pos
	MHz	dBuV/m	dB	dBuV/m	dBuV/m	dB		cm	Deg
1	4923.73	29.16	5.93	35.09	54.00	-18.91	Average	100	241
2	4923.73	41.07	5.93	47.00	74.00	-27.00	Peak	100	241

- Notes:
1. Result = Read Value + Factor
 2. Factor = Antenna Factor + Cable Loss - Amplifier
 3. The resolution bandwidth of test receiver/spectrum analyzer is 120KHz and video bandwidth is 300kHz for Peak detection and Quasi-peak detection at frequency below 1GHz.
 4. The resolution bandwidth of test receiver/spectrum analyzer is 1MHz and video bandwidth is 3MHz for Peak detection at frequency above 1GHz.
 5. The resolution bandwidth of test receiver/spectrum analyzer is 1MHz and video bandwidth is 10Hz for Average detection at frequency above 1GHz.
 6. The other emissions is too low to be measured.

Power	: AC 120V	Pol/Phase	: VERTICAL
Test Mode 1	: Transmit / Receive	Temperature	: 25 °C
Operation Channel	: 1	Humidity	: 65 %
Modulation Type	: 802.11g	Atmospheric Pressure	: 1020 hPa
Memo	: DSA-20P-10 US 120180	Rate	: 54Mbps

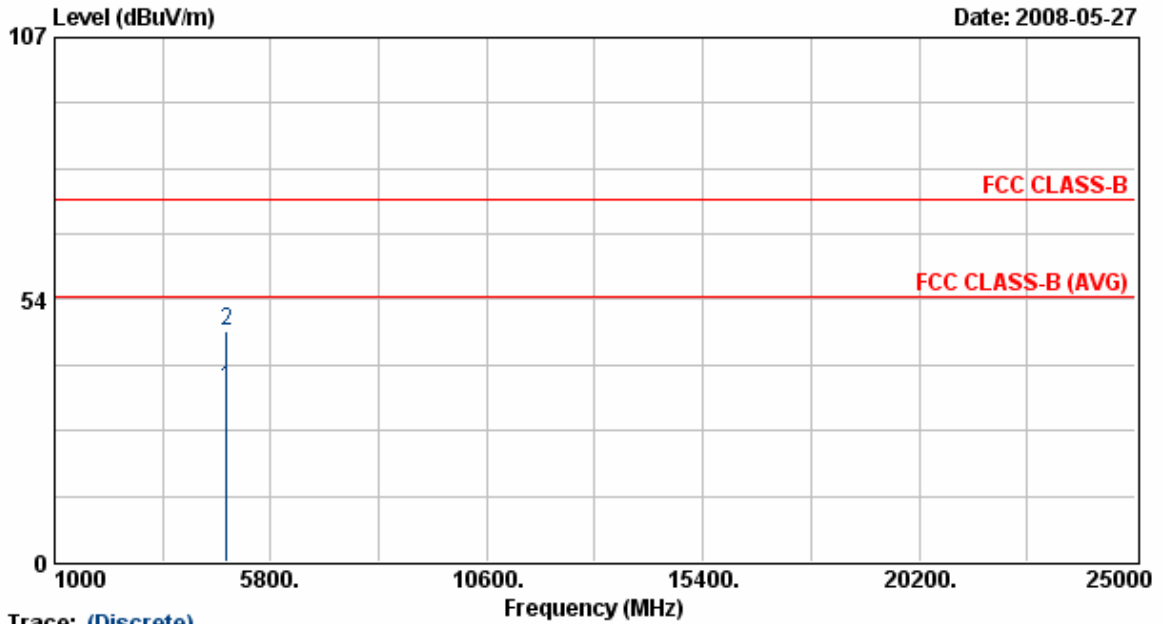

Trace: (Discrete)

Item	Freq	Read Value	Factor	Result	Limit	Margin	Remark	Ant Pos	Tab Pos
	MHz	dBuV/m	dB	dBuV/m	dBuV/m	dB		cm	Deg
1	4823.78	29.67	5.67	35.34	54.00	-18.66	Average	100	144
2	4823.78	41.57	5.67	47.24	74.00	-26.76	Peak	100	144

Notes:

1. Result = Read Value + Factor
2. Factor = Antenna Factor + Cable Loss - Amplifier
3. The resolution bandwidth of test receiver/spectrum analyzer is 120KHz and video bandwidth is 300kHz for Peak detection and Quasi-peak detection at frequency below 1GHz.
4. The resolution bandwidth of test receiver/spectrum analyzer is 1MHz and video bandwidth is 3MHz for Peak detection at frequency above 1GHz.
5. The resolution bandwidth of test receiver/spectrum analyzer is 1MHz and video bandwidth is 10Hz for Average detection at frequency above 1GHz.
6. The other emissions is too low to be measured.

Power	: AC 120V	Pol/Phase	: HORIZONTAL
Test Mode 1	: Transmit / Receive	Temperature	: 25 °C
Operation Channel	: 1	Humidity	: 65 %
Modulation Type	: 802.11g	Atmospheric Pressure	: 1020 hPa
Memo	: DSA-20P-10 US 120180	Rate	: 54Mbps

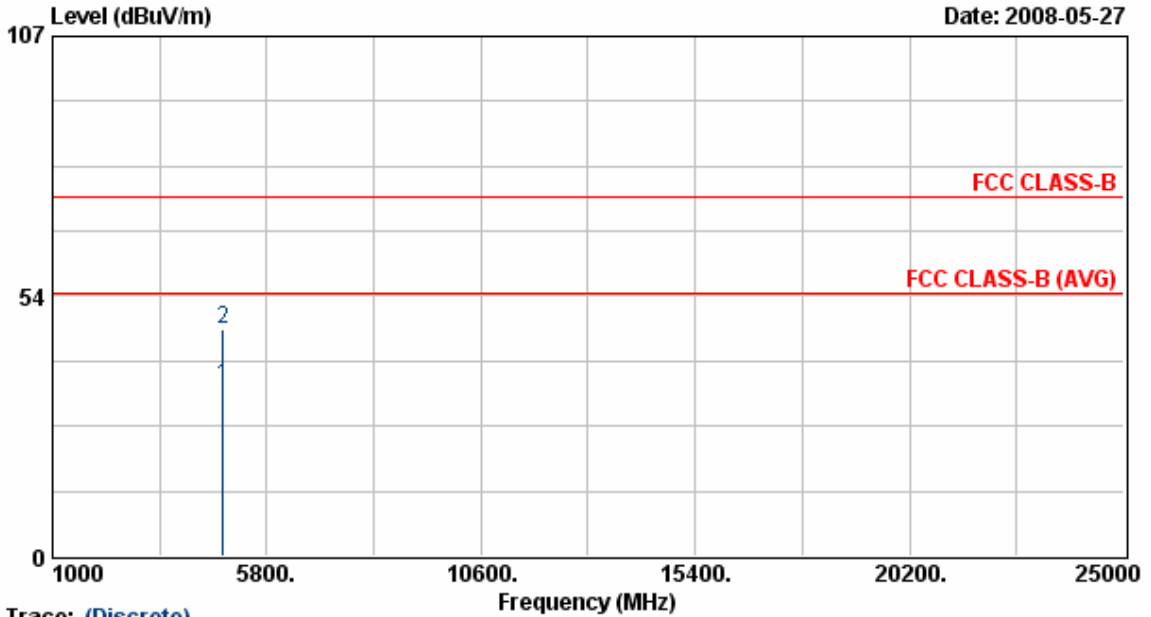

Trace: (Discrete)

Item	Freq	Read Value	Factor	Result	Limit	Margin	Remark	Ant Pos	Tab Pos
	MHz	dBuV/m	dB	dBuV/m	dBuV/m	dB		cm	Deg
1	4824.00	29.36	5.67	35.03	54.00	-18.97	Average	100	241
2	4824.00	41.20	5.67	46.88	74.00	-27.12	Peak	100	241

Notes:

1. Result = Read Value + Factor
2. Factor = Antenna Factor + Cable Loss - Amplifier
3. The resolution bandwidth of test receiver/spectrum analyzer is 120KHz and video bandwidth is 300kHz for Peak detection and Quasi-peak detection at frequency below 1GHz.
4. The resolution bandwidth of test receiver/spectrum analyzer is 1MHz and video bandwidth is 3MHz for Peak detection at frequency above 1GHz.
5. The resolution bandwidth of test receiver/spectrum analyzer is 1MHz and video bandwidth is 10Hz for Average detection at frequency above 1GHz.
6. The other emissions is too low to be measured.

Power	: AC 120V	Pol/Phase	: VERTICAL
Test Mode 1	: Transmit / Receive	Temperature	: 25 °C
Operation Channel	: 6	Humidity	: 65 %
Modulation Type	: 802.11g	Atmospheric Pressure	: 1020 hPa
Memo	: DSA-20P-10 US 120180	Rate	: 54Mbps

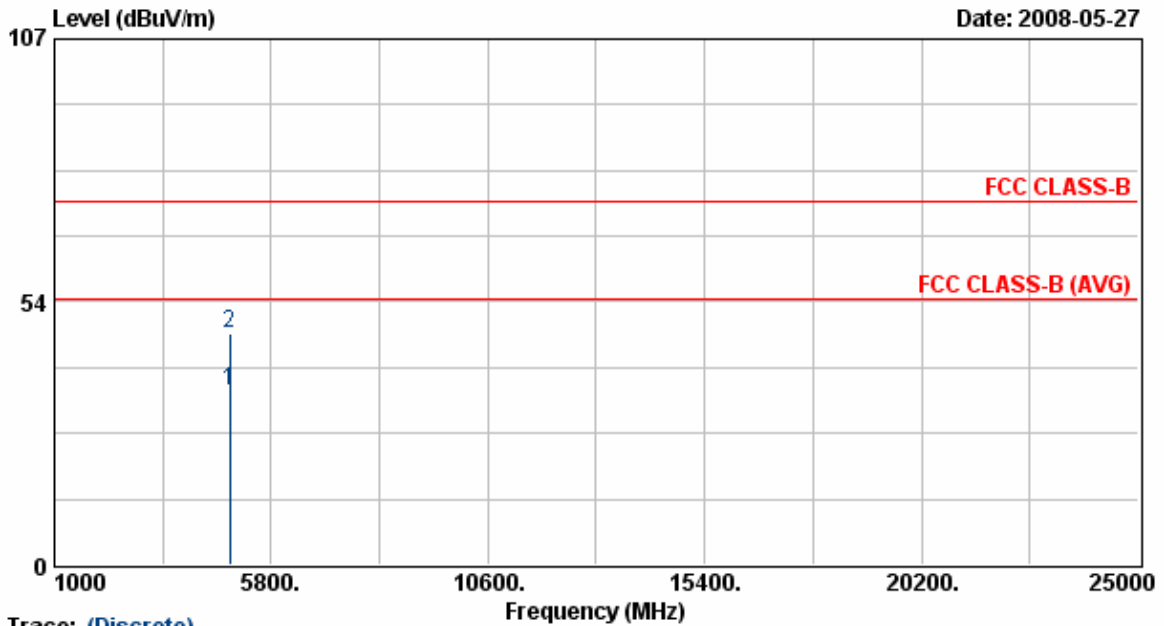

Trace: (Discrete)

Item	Freq	Read Value	Factor	Result	Limit	Margin	Remark	Ant Pos	Tab Pos
	MHz	dBuV/m	dB	dBuV/m	dBuV/m	dB		cm	Deg
1	4873.78	29.57	5.80	35.37	54.00	-18.63	Average	100	144
2	4873.78	41.47	5.80	47.27	74.00	-26.73	Peak	100	144

Notes:

1. Result = Read Value + Factor
2. Factor = Antenna Factor + Cable Loss - Amplifier
3. The resolution bandwidth of test receiver/spectrum analyzer is 120KHz and video bandwidth is 300kHz for Peak detection and Quasi-peak detection at frequency below 1GHz.
4. The resolution bandwidth of test receiver/spectrum analyzer is 1MHz and video bandwidth is 3MHz for Peak detection at frequency above 1GHz.
5. The resolution bandwidth of test receiver/spectrum analyzer is 1MHz and video bandwidth is 10Hz for Average detection at frequency above 1GHz.
6. The other emissions is too low to be measured.

Power	: AC 120V	Pol/Phase	: HORIZONTAL
Test Mode 1	: Transmit / Receive	Temperature	: 25 °C
Operation Channel	: 6	Humidity	: 65 %
Modulation Type	: 802.11g	Atmospheric Pressure	: 1020 hPa
Memo	: DSA-20P-10 US 120180	Rate	: 54Mbps

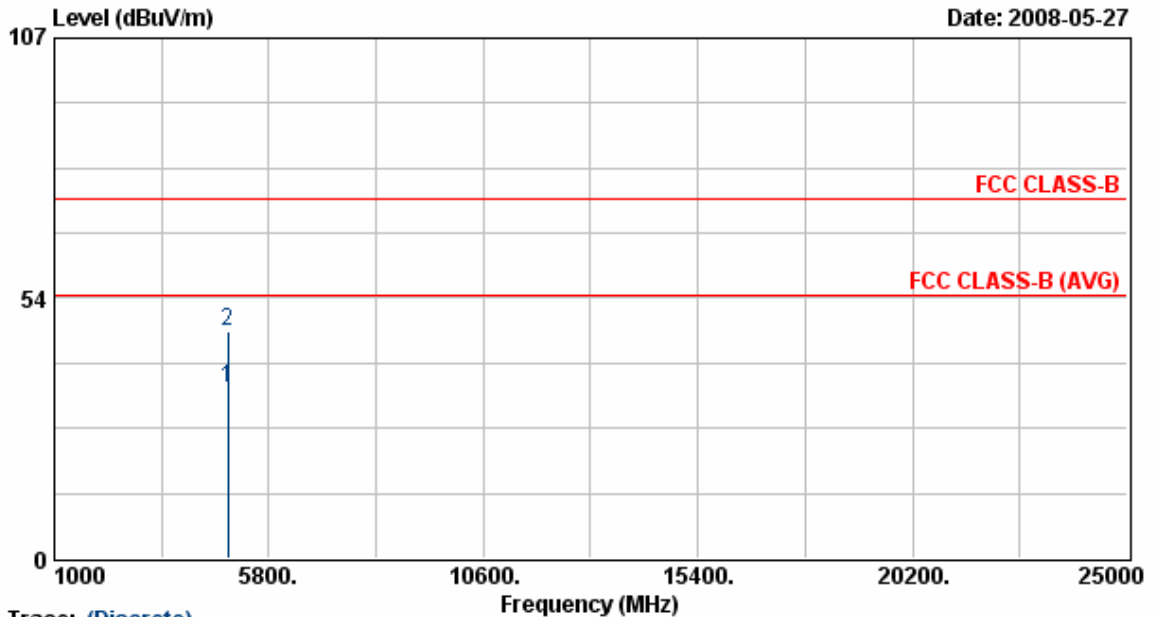

Trace: (Discrete)

Item	Freq	Read Value	Factor	Result	Limit	Margin	Remark	Ant Pos	Tab Pos
	MHz	dBuV/m	dB	dBuV/m	dBuV/m	dB		cm	Deg
1	4874.03	29.38	5.80	35.18	54.00	-18.82	Average	100	241
2	4874.03	41.05	5.80	46.85	74.00	-27.15	Peak	100	241

Notes:

1. Result = Read Value + Factor
2. Factor = Antenna Factor + Cable Loss - Amplifier
3. The resolution bandwidth of test receiver/spectrum analyzer is 120KHz and video bandwidth is 300kHz for Peak detection and Quasi-peak detection at frequency below 1GHz.
4. The resolution bandwidth of test receiver/spectrum analyzer is 1MHz and video bandwidth is 3MHz for Peak detection at frequency above 1GHz.
5. The resolution bandwidth of test receiver/spectrum analyzer is 1MHz and video bandwidth is 10Hz for Average detection at frequency above 1GHz.
6. The other emissions is too low to be measured.

Power	: AC 120V	Pol/Phase	: VERTICAL
Test Mode 1	: Transmit / Receive	Temperature	: 25 °C
Operation Channel	: 11	Humidity	: 65 %
Modulation Type	: 802.11g	Atmospheric Pressure	: 1020 hPa
Memo	: DSA-20P-10 US 120180	Rate	: 54Mbps

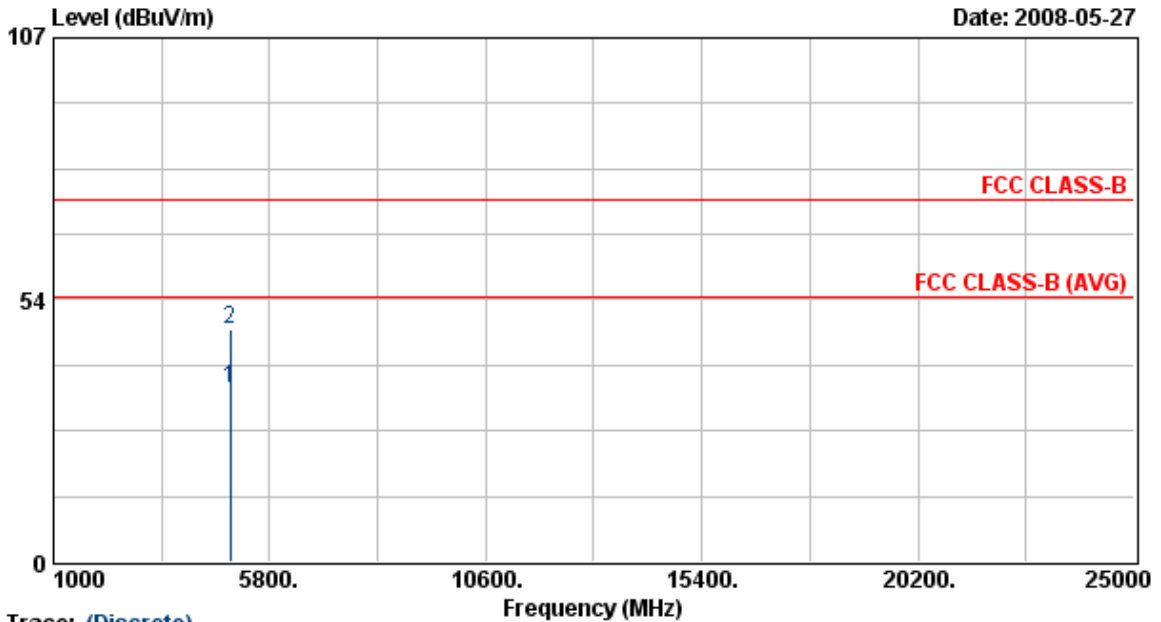

Trace: (Discrete)

Item	Freq	Read Value	Factor	Result	Limit	Margin	Remark	Ant Pos	Tab Pos
	MHz	dBuV/m	dB	dBuV/m	dBuV/m	dB		cm	Deg
1	4924.00	29.67	5.93	35.60	54.00	-18.40	Average	100	144
2	4924.00	41.37	5.93	47.30	74.00	-26.70	Peak	100	144

Notes:

1. Result = Read Value + Factor
2. Factor = Antenna Factor + Cable Loss - Amplifier
3. The resolution bandwidth of test receiver/spectrum analyzer is 120KHz and video bandwidth is 300kHz for Peak detection and Quasi-peak detection at frequency below 1GHz.
4. The resolution bandwidth of test receiver/spectrum analyzer is 1MHz and video bandwidth is 3MHz for Peak detection at frequency above 1GHz.
5. The resolution bandwidth of test receiver/spectrum analyzer is 1MHz and video bandwidth is 10Hz for Average detection at frequency above 1GHz.
6. The other emissions is too low to be measured.

Power	: AC 120V	Pol/Phase	: HORIZONTAL
Test Mode 1	: Transmit / Receive	Temperature	: 25 °C
Operation Channel	: 11	Humidity	: 65 %
Modulation Type	: 802.11g	Atmospheric Pressure	: 1020 hPa
Memo	: DSA-20P-10 US 120180	Rate	: 54Mbps

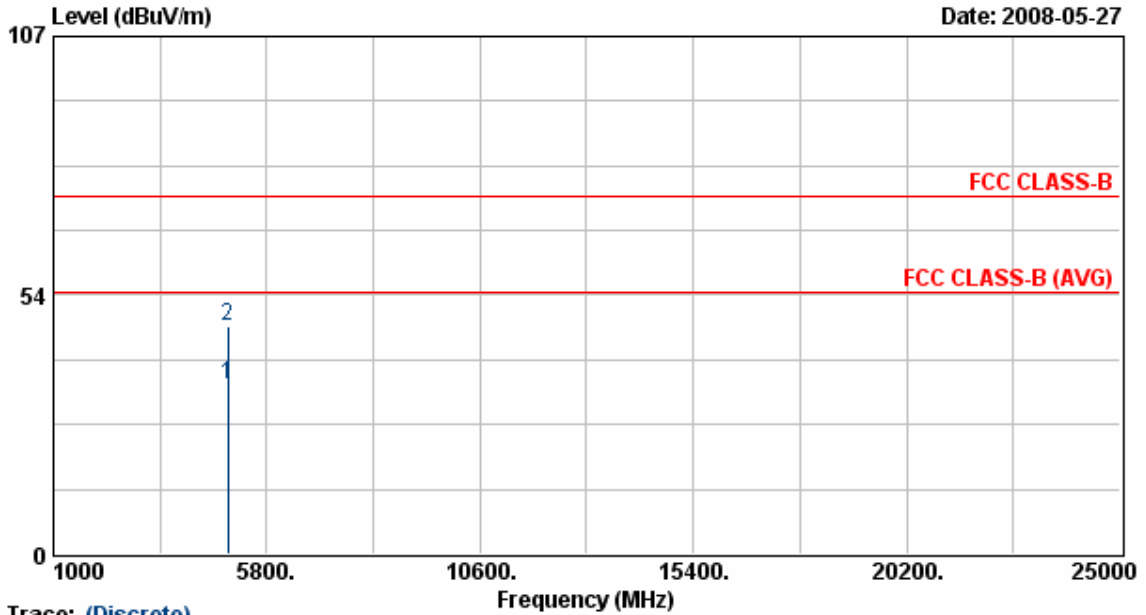

Trace: (Discrete)

Item	Freq	Read Value	Factor	Result	Limit	Margin	Remark	Ant Pos	Tab Pos
	MHz	dBuV/m	dB	dBuV/m	dBuV/m	dB		cm	Deg
1	4923.90	29.24	5.93	35.17	54.00	-18.83	Average	100	241
2	4923.90	41.04	5.93	46.97	74.00	-27.03	Peak	100	241

Notes:

1. Result = Read Value + Factor
2. Factor = Antenna Factor + Cable Loss - Amplifier
3. The resolution bandwidth of test receiver/spectrum analyzer is 120KHz and video bandwidth is 300kHz for Peak detection and Quasi-peak detection at frequency below 1GHz.
4. The resolution bandwidth of test receiver/spectrum analyzer is 1MHz and video bandwidth is 3MHz for Peak detection at frequency above 1GHz.
5. The resolution bandwidth of test receiver/spectrum analyzer is 1MHz and video bandwidth is 10Hz for Average detection at frequency above 1GHz.
6. The other emissions is too low to be measured.

Power	: AC 120V	Pol/Phase	: VERTICAL
Test Mode 1	: Transmit / Receive	Temperature	: 25 °C
Operation Channel	: 1	Humidity	: 65 %
Modulation Type	: 802.11n, HT20	Atmospheric Pressure	: 1020 hPa
Memo	: DSA-20P-10 US 120180	Rate	: 130Mbps

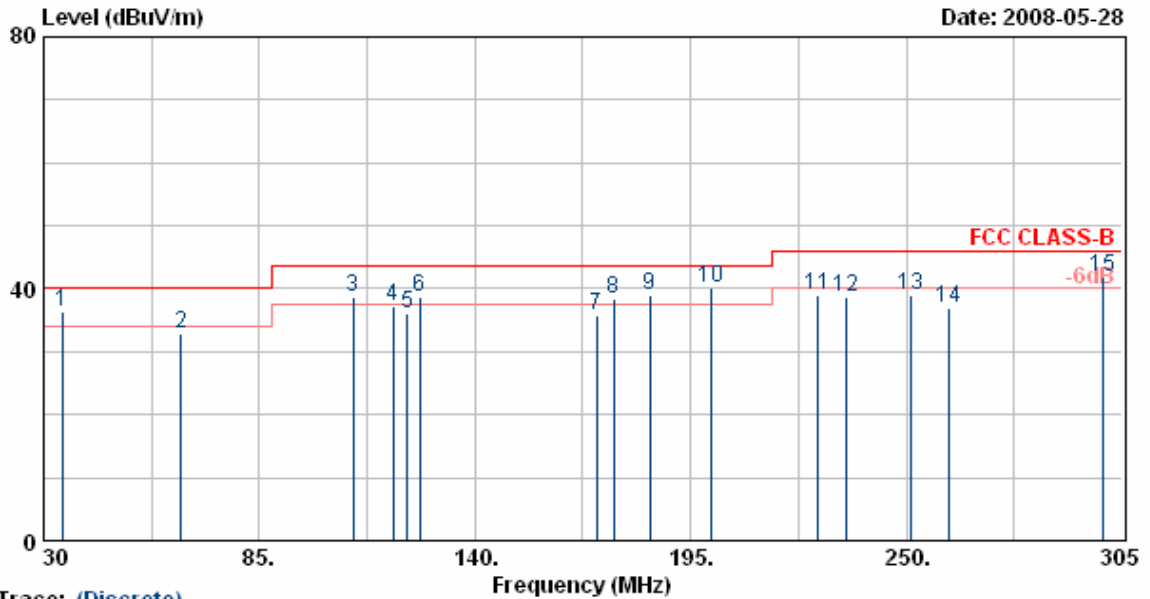

Trace: (Discrete)

Item	Freq	Read Value	Factor	Result	Limit	Margin	Remark	Ant Pos	Tab Pos
	MHz	dBuV/m	dB	dBuV/m	dBuV/m	dB		cm	Deg
1	34.67	44.50	-8.08	36.42	40.00	-3.58	QP	100	66
2	64.93	52.22	-19.28	32.94	40.00	-7.06	Peak	100	66
3	108.90	52.22	-13.48	38.74	43.50	-4.76	QP	100	105
4	119.10	50.78	-13.49	37.29	43.50	-6.21	Peak	100	22
5	122.68	49.53	-13.47	36.06	43.50	-7.44	Peak	100	95
6	125.98	52.45	-13.65	38.80	43.50	-4.70	QP	100	103
7	171.08	47.45	-11.81	35.64	43.50	-7.86	Peak	100	83
8	175.44	48.20	-9.71	38.49	43.50	-5.01	QP	100	83
9	184.55	48.39	-9.51	38.88	43.50	-4.62	QP	100	50
10	200.00	52.04	-11.75	40.29	43.50	-3.21	QP	100	50
11	227.18	51.50	-12.42	39.08	46.00	-6.92	Peak	100	50
12	234.60	48.44	-9.75	38.69	46.00	-7.31	Peak	100	95
13	251.10	51.42	-12.33	39.09	46.00	-6.91	Peak	100	144
14	260.73	46.80	-9.73	37.07	46.00	-8.93	Peak	100	122
15	300.00	51.42	-9.50	41.92	46.00	-4.08	QP	100	41

Notes:

1. Result = Read Value + Factor
2. Factor = Antenna Factor + Cable Loss - Amplifier
3. The resolution bandwidth of test receiver/spectrum analyzer is 120KHz and video bandwidth is 300kHz for Peak detection and Quasi-peak detection at frequency below 1GHz.
4. According to technical experiences, all spurious emission of 802.11MIMO mode at channel 1,6,11 are almost the same below 1GHz, so that the channel 1 was chosen as representative in final test.
5. The data is worse case.

Power	: AC 120V	Pol/Phase	: VERTICAL
Test Mode 1	: Transmit / Receive	Temperature	: 25 °C
Operation Channel	: 1	Humidity	: 65 %
Modulation Type	: 802.11n, HT20	Atmospheric Pressure	: 1020 hPa
Memo	: DSA-20P-10 US 120180	Rate	: 130Mbps

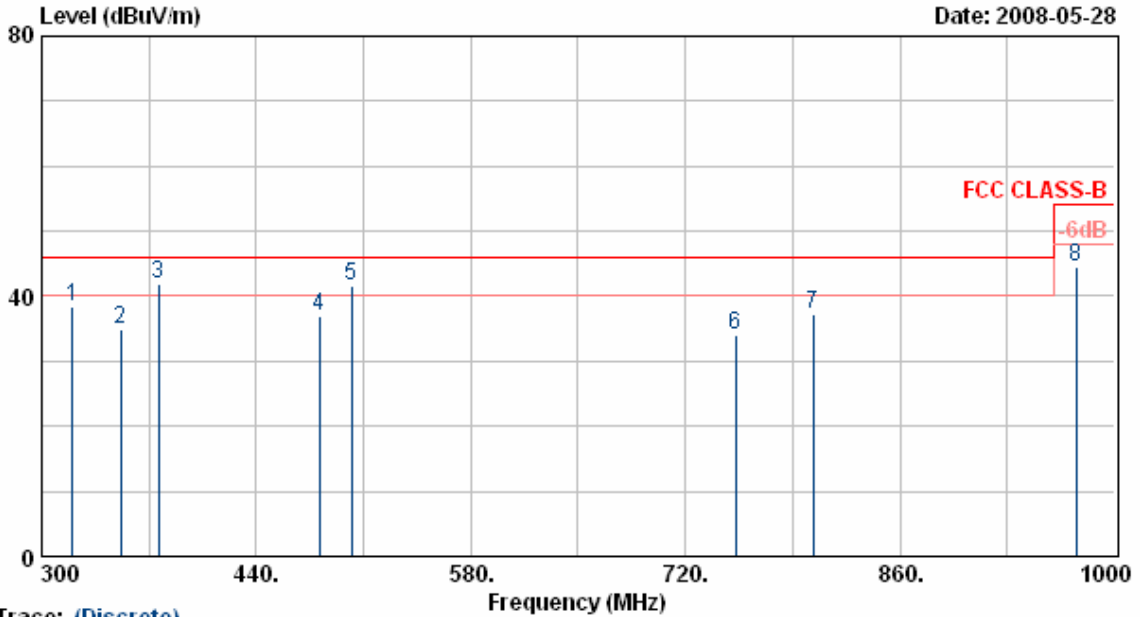

Trace: (Discrete)

Item	Freq	Read Value	Factor	Result	Limit	Margin	Remark	Ant Pos	Tab Pos
	MHz	dBuV/m	dB	dBuV/m	dBuV/m	dB		cm	Deg
1	320.30	48.90	-10.38	38.52	46.00	-7.48	Peak	100	74
2	351.80	45.55	-10.65	34.90	46.00	-11.10	Peak	100	105
3	376.30	51.16	-9.17	41.99	46.00	-4.01	QP	100	105
4	481.30	41.72	-4.66	37.06	46.00	-8.94	Peak	100	144
5	502.30	46.55	-4.95	41.60	46.00	-4.40	QP	100	201
6	752.90	33.52	0.38	33.90	46.00	-12.10	Peak	100	201
7	803.30	39.87	-2.76	37.11	46.00	-8.89	Peak	100	74
8	974.80	41.00	3.45	44.45	54.00	-9.55	Peak	100	122

Notes:

1. Result = Read Value + Factor
2. Factor = Antenna Factor + Cable Loss - Amplifier
3. The resolution bandwidth of test receiver/spectrum analyzer is 120KHz and video bandwidth is 300kHz for Peak detection and Quasi-peak detection at frequency below 1GHz.
4. According to technical experiences, all spurious emission of 802.11MIMO mode at channel 1,6,11 are almost the same below 1GHz, so that the channel 1 was chosen as representative in final test.
5. The data is worse case.

Power	: AC 120V	Pol/Phase	: HORIZONTAL
Test Mode 1	: Transmit / Receive	Temperature	: 25 °C
Operation Channel	: 1	Humidity	: 65 %
Modulation Type	: 802.11n, HT20	Atmospheric Pressure	: 1020 hPa
Memo	: DSA-20P-10 US 120180	Rate	: 130Mbps

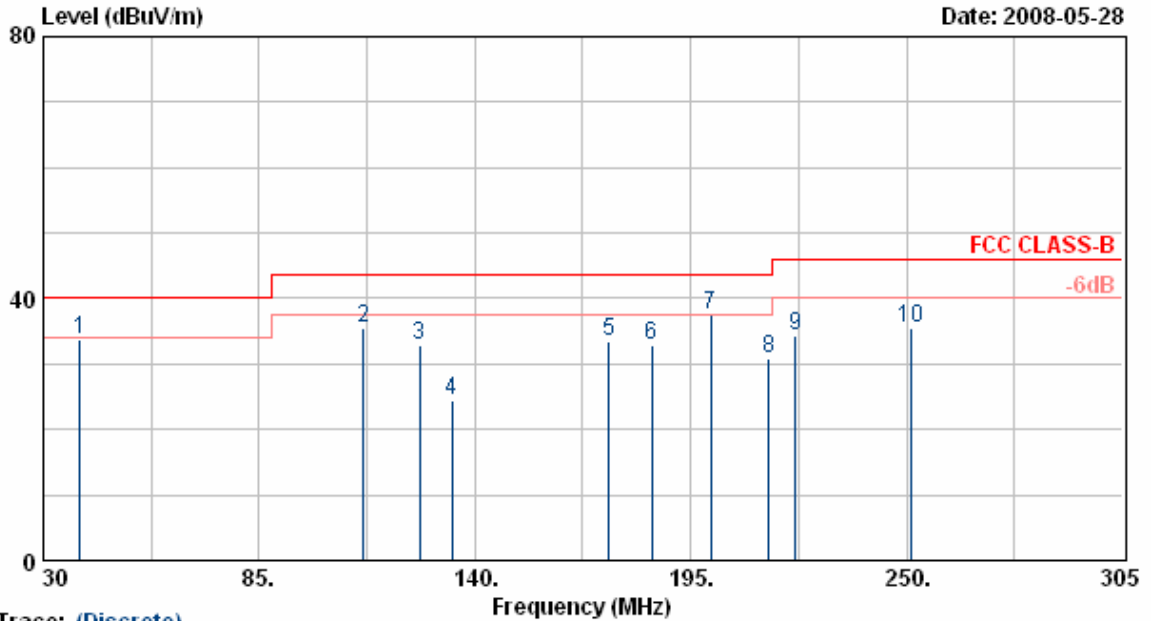

Trace: (Discrete)

Item	Freq	Read Value	Factor	Result	Limit	Margin	Remark	Ant Pos	Tab Pos
	MHz	dBuV/m	dB	dBuV/m	dBuV/m	dB		cm	Deg
1	39.35	48.49	-14.87	33.62	40.00	-6.38	Peak	200	45
2	111.70	54.77	-19.23	35.53	43.50	-7.97	Peak	200	147
3	125.98	52.56	-19.62	32.94	43.50	-10.56	Peak	200	152
4	134.23	43.78	-19.35	24.43	43.50	-19.07	Peak	200	222
5	174.10	51.50	-17.94	33.56	43.50	-9.94	Peak	200	188
6	185.10	50.80	-17.81	32.99	43.50	-10.51	Peak	200	28
7	200.01	51.90	-14.49	37.41	43.50	-6.09	Peak	200	222
8	215.00	49.33	-18.48	30.85	43.50	-12.65	Peak	200	87
9	221.70	52.52	-18.06	34.46	46.00	-11.54	Peak	200	157
10	251.10	52.83	-17.31	35.52	46.00	-10.48	Peak	200	255

Notes:

1. Result = Read Value + Factor
2. Factor = Antenna Factor + Cable Loss - Amplifier
3. The resolution bandwidth of test receiver/spectrum analyzer is 120KHz and video bandwidth is 300kHz for Peak detection and Quasi-peak detection at frequency below 1GHz.
4. According to technical experiences, all spurious emission of 802.11MIMO mode at channel 1,6,11 are almost the same below 1GHz, so that the channel 1 was chosen as representative in final test.
5. The data is worse case.

Power	: AC 120V	Pol/Phase	: HORIZONTAL
Test Mode 1	: Transmit / Receive	Temperature	: 25 °C
Operation Channel	: 1	Humidity	: 65 %
Modulation Type	: 802.11n, HT20	Atmospheric Pressure	: 1020 hPa
Memo	: DSA-20P-10 US 120180	Rate	: 130Mbps

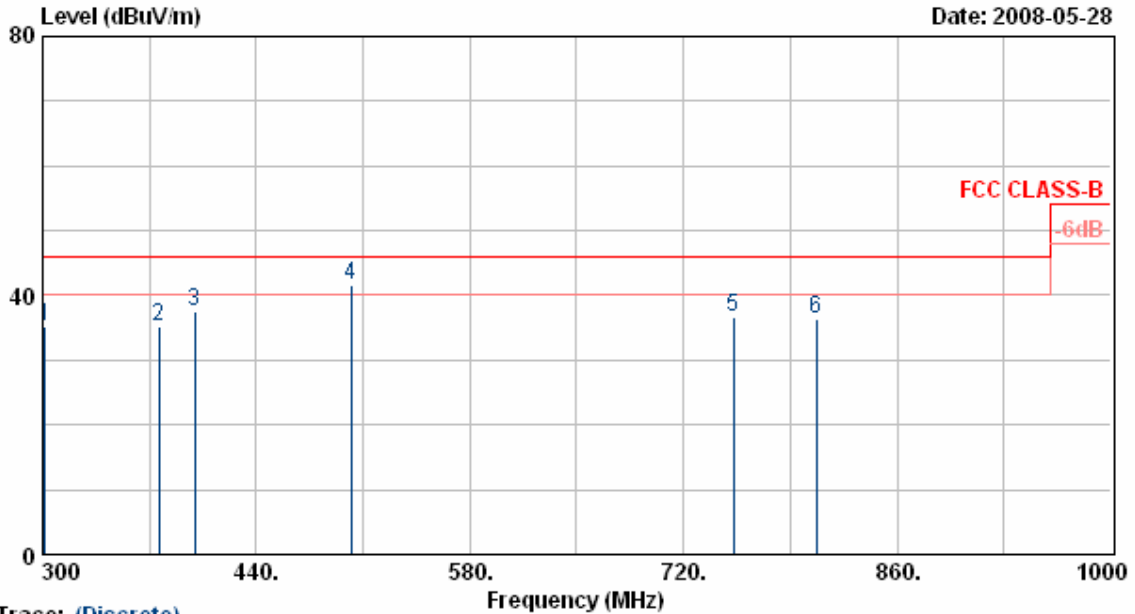

Trace: (Discrete)

Item	Freq	Read Value	Factor	Result	Limit	Margin	Remark	Ant Pos	Tab Pos
	MHz	dBuV/m	dB	dBuV/m	dBuV/m	dB		cm	Deg
1	301.40	49.55	-14.33	35.22	46.00	-10.78	Peak	200	333
2	376.30	46.20	-10.87	35.33	46.00	-10.67	Peak	200	99
3	399.40	48.66	-11.05	37.61	46.00	-8.39	Peak	200	232
4	502.30	46.68	-5.03	41.65	46.00	-4.35	QP	200	299
5	752.90	36.66	-0.03	36.63	46.00	-9.37	Peak	200	299
6	806.80	36.70	-0.43	36.27	46.00	-9.73	Peak	200	333

Notes:

1. Result = Read Value + Factor
2. Factor = Antenna Factor + Cable Loss - Amplifier
3. The resolution bandwidth of test receiver/spectrum analyzer is 120KHz and video bandwidth is 300kHz for Peak detection and Quasi-peak detection at frequency below 1GHz.
4. According to technical experiences, all spurious emission of 802.11MIMO mode at channel 1,6,11 are almost the same below 1GHz, so that the channel 1 was chosen as representative in final test.
5. The data is worse case.

Power	: AC 120V	Pol/Phase	: VERTICAL
Test Mode 1	: Transmit / Receive	Temperature	: 25 °C
Operation Channel	: 1	Humidity	: 65 %
Modulation Type	: 802.11n, HT20	Atmospheric Pressure	: 1020 hPa
Memo	: DSA-20P-10 US 120180	Rate	: 130Mbps

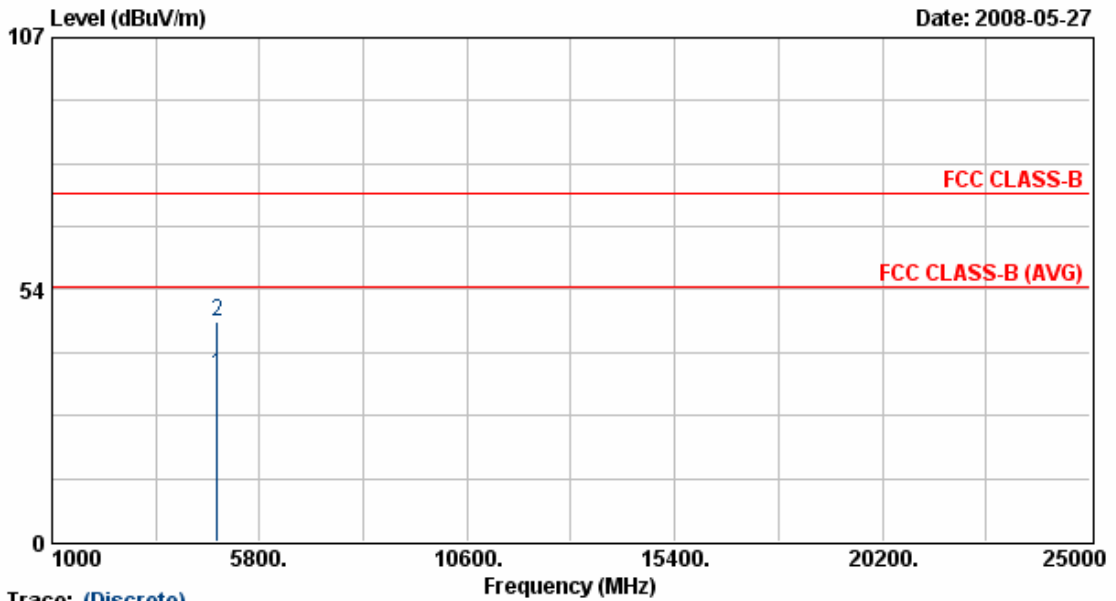

Trace: (Discrete)

Item	Freq	Read Value	Factor	Result	Limit	Margin	Remark	Ant Pos	Tab Pos
	MHz	dBuV/m	dB	dBuV/m	dBuV/m	dB		cm	Deg
1	4824.05	29.56	5.67	35.23	54.00	-18.77	Average	100	144
2	4824.05	41.14	5.67	46.81	74.00	-27.19	Peak	100	144

Notes:

1. Result = Read Value + Factor
2. Factor = Antenna Factor + Cable Loss - Amplifier
3. The resolution bandwidth of test receiver/spectrum analyzer is 120KHz and video bandwidth is 300kHz for Peak detection and Quasi-peak detection at frequency below 1GHz.
4. The resolution bandwidth of test receiver/spectrum analyzer is 1MHz and video bandwidth is 3MHz for Peak detection at frequency above 1GHz.
5. The resolution bandwidth of test receiver/spectrum analyzer is 1MHz and video bandwidth is 10Hz for Average detection at frequency above 1GHz.
6. The other emissions is too low to be measured.

Power	: AC 120V	Pol/Phase	: HORIZONTAL
Test Mode 1	: Transmit / Receive	Temperature	: 25 °C
Operation Channel	: 1	Humidity	: 65 %
Modulation Type	: 802.11n, HT20	Atmospheric Pressure	: 1020 hPa
Memo	: DSA-20P-10 US 120180	Rate	: 130Mbps

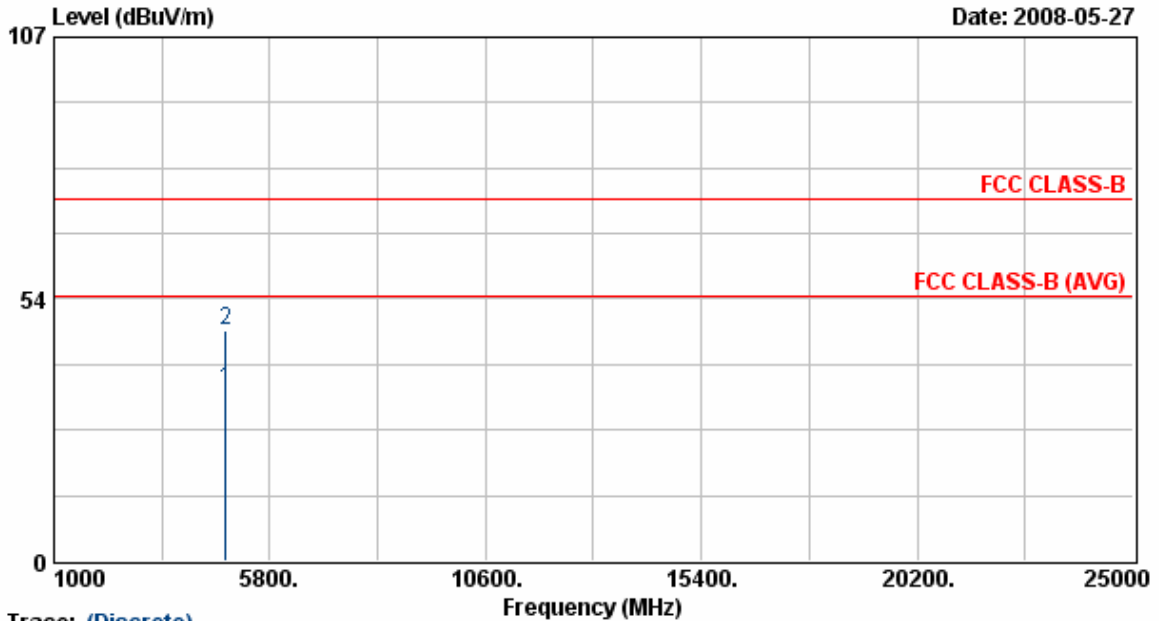

Trace: (Discrete)

Item	Freq	Read Value	Factor	Result	Limit	Margin	Remark	Ant Pos	Tab Pos
	MHz	dBuV/m	dB	dBuV/m	dBuV/m	dB		cm	Deg
1	4824.05	29.36	5.67	35.04	54.00	-18.96	Average	100	241
2	4824.05	41.22	5.67	46.90	74.00	-27.10	Peak	100	241

Notes:

1. Result = Read Value + Factor
2. Factor = Antenna Factor + Cable Loss - Amplifier
3. The resolution bandwidth of test receiver/spectrum analyzer is 120KHz and video bandwidth is 300kHz for Peak detection and Quasi-peak detection at frequency below 1GHz.
4. The resolution bandwidth of test receiver/spectrum analyzer is 1MHz and video bandwidth is 3MHz for Peak detection at frequency above 1GHz.
5. The resolution bandwidth of test receiver/spectrum analyzer is 1MHz and video bandwidth is 10Hz for Average detection at frequency above 1GHz.
6. The other emissions is too low to be measured.

Power	: AC 120V	Pol/Phase	: VERTICAL
Test Mode 1	: Transmit / Receive	Temperature	: 25 °C
Operation Channel	: 6	Humidity	: 65 %
Modulation Type	: 802.11n, HT20	Atmospheric Pressure	: 1020 hPa
Memo	: DSA-20P-10 US 120180	Rate	: 130Mbps

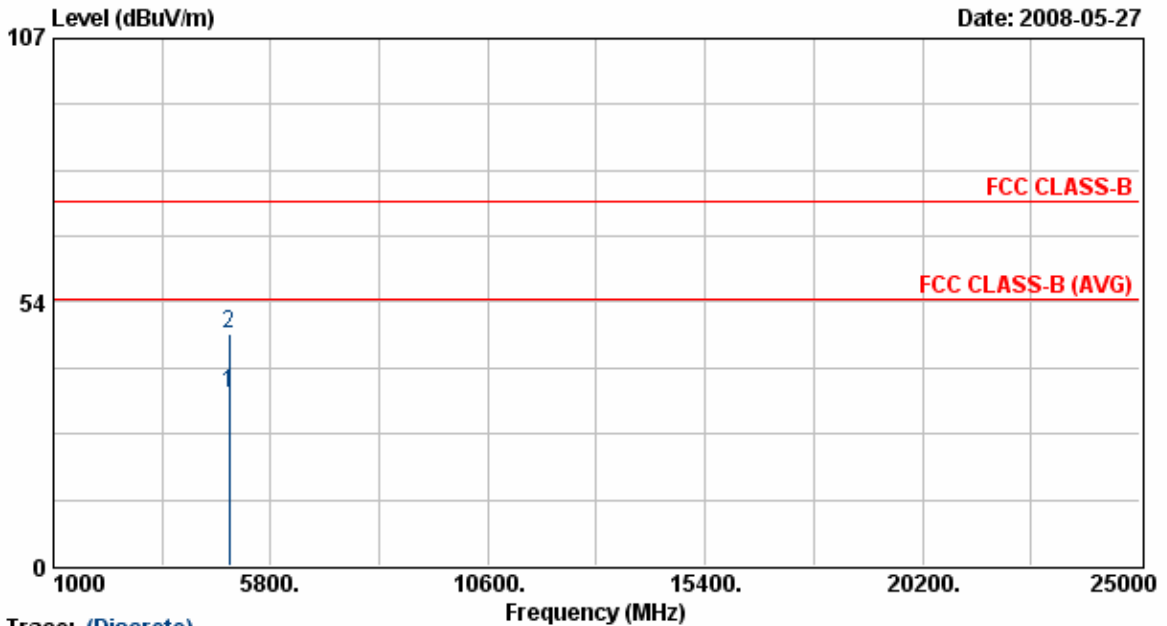

Trace: (Discrete)

Item	Freq	Read Value	Factor	Result	Limit	Margin	Remark	Ant Pos	Tab Pos
	MHz	dBuV/m	dB	dBuV/m	dBuV/m	dB		cm	Deg
1	4874.05	29.38	5.80	35.19	54.00	-18.81	Average	100	144
2	4874.05	41.31	5.80	47.11	74.00	-26.89	Peak	100	144

Notes:

1. Result = Read Value + Factor
2. Factor = Antenna Factor + Cable Loss - Amplifier
3. The resolution bandwidth of test receiver/spectrum analyzer is 120KHz and video bandwidth is 300kHz for Peak detection and Quasi-peak detection at frequency below 1GHz.
4. The resolution bandwidth of test receiver/spectrum analyzer is 1MHz and video bandwidth is 3MHz for Peak detection at frequency above 1GHz.
5. The resolution bandwidth of test receiver/spectrum analyzer is 1MHz and video bandwidth is 10Hz for Average detection at frequency above 1GHz.
6. The other emissions is too low to be measured.

Power	: AC 120V	Pol/Phase	: HORIZONTAL
Test Mode 1	: Transmit / Receive	Temperature	: 25 °C
Operation Channel	: 6	Humidity	: 65 %
Modulation Type	: 802.11n, HT20	Atmospheric Pressure	: 1020 hPa
Memo	: DSA-20P-10 US 120180	Rate	: 130Mbps

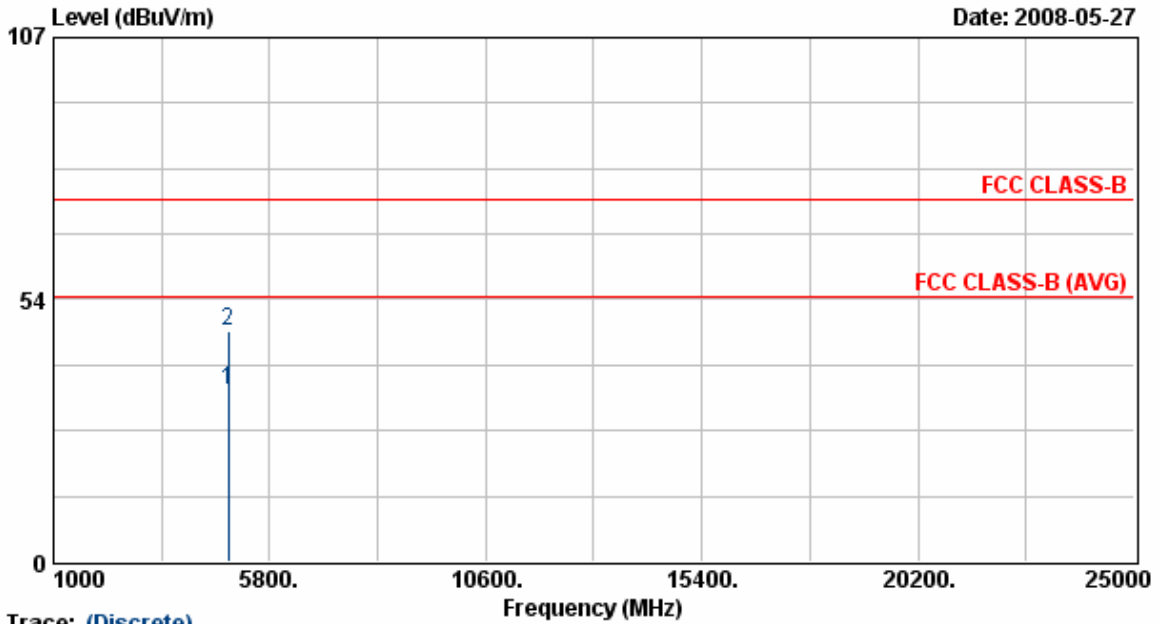

Trace: (Discrete)

Item	Freq	Read Value	Factor	Result	Limit	Margin	Remark	Ant Pos	Tab Pos
	MHz	dBuV/m	dB	dBuV/m	dBuV/m	dB		cm	Deg
1	4874.10	29.27	5.80	35.07	54.00	-18.93	Average	100	241
2	4874.10	41.22	5.80	47.03	74.00	-26.97	Peak	100	241

Notes:

1. Result = Read Value + Factor
2. Factor = Antenna Factor + Cable Loss - Amplifier
3. The resolution bandwidth of test receiver/spectrum analyzer is 120KHz and video bandwidth is 300kHz for Peak detection and Quasi-peak detection at frequency below 1GHz.
4. The resolution bandwidth of test receiver/spectrum analyzer is 1MHz and video bandwidth is 3MHz for Peak detection at frequency above 1GHz.
5. The resolution bandwidth of test receiver/spectrum analyzer is 1MHz and video bandwidth is 10Hz for Average detection at frequency above 1GHz.
6. The other emissions is too low to be measured.

Power	: AC 120V	Pol/Phase	: VERTICAL
Test Mode 1	: Transmit / Receive	Temperature	: 25 °C
Operation Channel	: 11	Humidity	: 65 %
Modulation Type	: 802.11n, HT20	Atmospheric Pressure	: 1020 hPa
Memo	: DSA-20P-10 US 120180	Rate	: 130Mbps

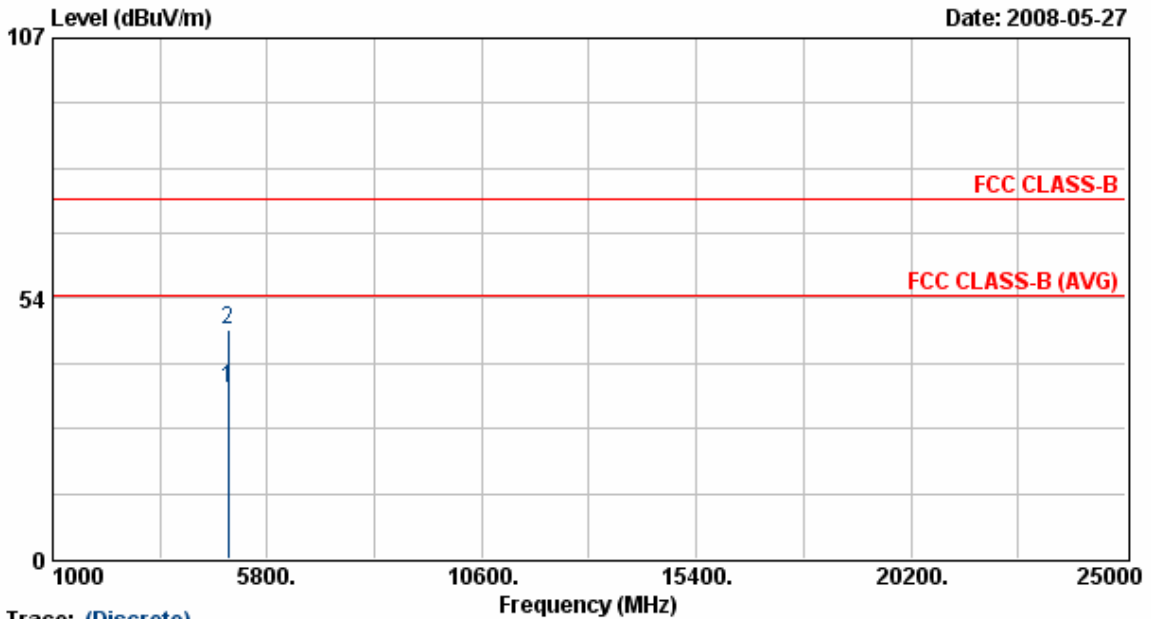

Trace: (Discrete)

Item	Freq	Read Value	Factor	Result	Limit	Margin	Remark	Ant Pos	Tab Pos
	MHz	dBuV/m	dB	dBuV/m	dBuV/m	dB		cm	Deg
1	4923.90	29.13	5.93	35.07	54.00	-18.93	Average	100	144
2	4923.90	41.07	5.93	47.00	74.00	-27.00	Peak	100	144

Notes:

1. Result = Read Value + Factor
2. Factor = Antenna Factor + Cable Loss - Amplifier
3. The resolution bandwidth of test receiver/spectrum analyzer is 120KHz and video bandwidth is 300kHz for Peak detection and Quasi-peak detection at frequency below 1GHz.
4. The resolution bandwidth of test receiver/spectrum analyzer is 1MHz and video bandwidth is 3MHz for Peak detection at frequency above 1GHz.
5. The resolution bandwidth of test receiver/spectrum analyzer is 1MHz and video bandwidth is 10Hz for Average detection at frequency above 1GHz.
6. The other emissions is too low to be measured.

Power	: AC 120V	Pol/Phase	: HORIZONTAL
Test Mode 1	: Transmit / Receive	Temperature	: 25 °C
Operation Channel	: 11	Humidity	: 65 %
Modulation Type	: 802.11n, HT20	Atmospheric Pressure	: 1020 hPa
Memo	: DSA-20P-10 US 120180	Rate	: 130Mbps

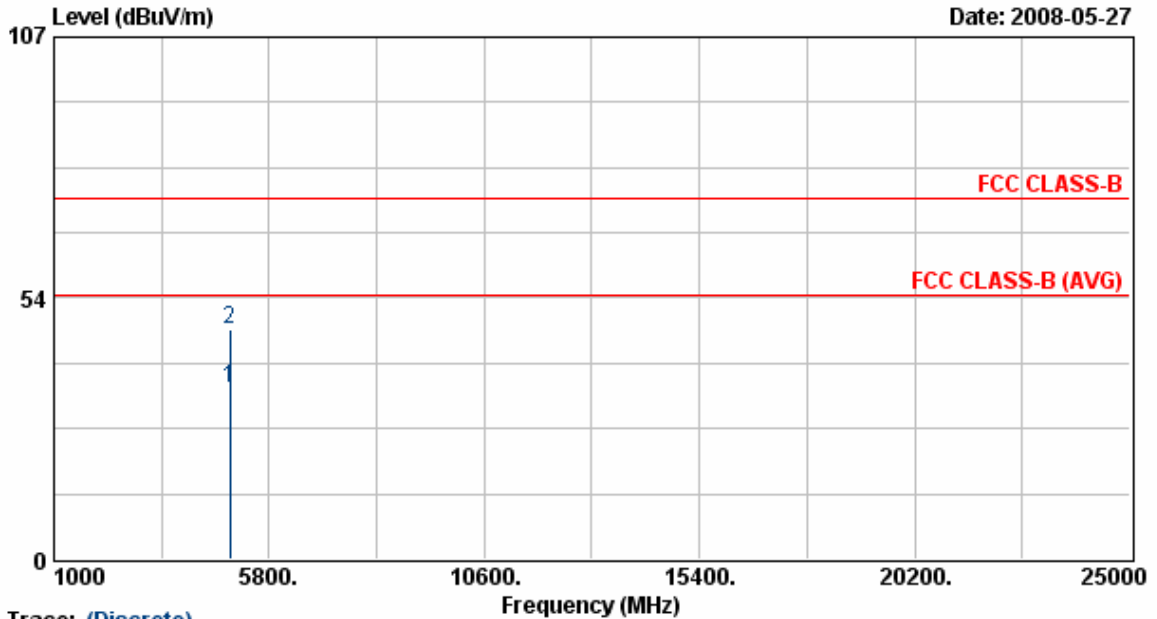

Trace: (Discrete)

Item	Freq	Read Value	Factor	Result	Limit	Margin	Remark	Ant Pos	Tab Pos
	MHz	dBuV/m	dB	dBuV/m	dBuV/m	dB		cm	Deg
1	4924.05	29.13	5.93	35.07	54.00	-18.93	Average	100	241
2	4924.05	41.03	5.93	46.97	74.00	-27.03	Peak	100	241

Notes:

1. Result = Read Value + Factor
2. Factor = Antenna Factor + Cable Loss - Amplifier
3. The resolution bandwidth of test receiver/spectrum analyzer is 120KHz and video bandwidth is 300kHz for Peak detection and Quasi-peak detection at frequency below 1GHz.
4. The resolution bandwidth of test receiver/spectrum analyzer is 1MHz and video bandwidth is 3MHz for Peak detection at frequency above 1GHz.
5. The resolution bandwidth of test receiver/spectrum analyzer is 1MHz and video bandwidth is 10Hz for Average detection at frequency above 1GHz.
6. The other emissions is too low to be measured.

Power	: AC 120V	Pol/Phase	: VERTICAL
Test Mode 1	: Transmit / Receive	Temperature	: 25 °C
Operation Channel	: 3	Humidity	: 65 %
Modulation Type	: 802.11n, HT40	Atmospheric Pressure	: 1020 hPa
Memo	: DSA-20P-10 US 120180	Rate	: 270Mbps

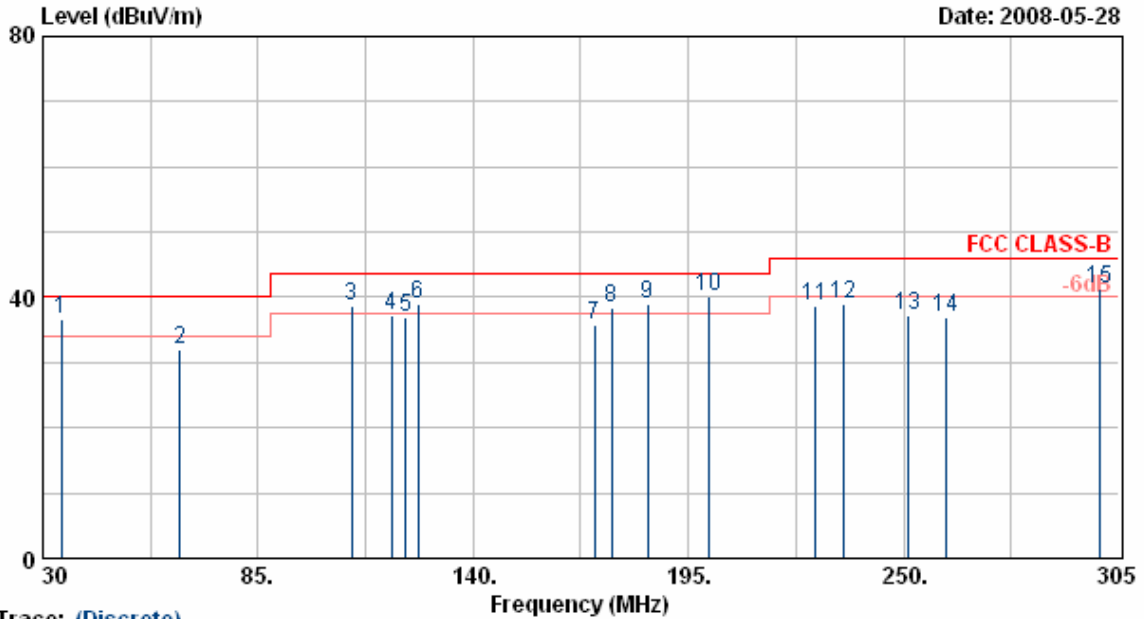

Trace: (Discrete)

Item	Freq MHz	Read Value dBuV/m	Factor dB	Result dBuV/m	Limit dBuV/m	Margin dB	Remark	Ant Pos cm	Tab Pos Deg
1	34.67	44.70	-8.08	36.62	40.00	-3.38	QP	100	66
2	64.93	51.17	-19.28	31.89	40.00	-8.11	Peak	100	66
3	108.90	52.22	-13.48	38.74	43.50	-4.76	QP	100	105
4	119.10	50.68	-13.49	37.19	43.50	-6.31	Peak	100	22
5	122.68	50.50	-13.47	37.03	43.50	-6.47	Peak	100	95
6	125.98	52.52	-13.65	38.87	43.50	-4.63	QP	100	103
7	171.08	47.60	-11.81	35.79	43.50	-7.71	Peak	100	83
8	175.44	48.23	-9.71	38.52	43.50	-4.98	QP	100	83
9	184.55	48.55	-9.51	39.04	43.50	-4.46	QP	100	50
10	200.00	52.00	-11.75	40.25	43.50	-3.25	QP	100	50
11	227.18	51.17	-12.42	38.75	46.00	-7.25	Peak	100	50
12	234.60	48.62	-9.75	38.87	46.00	-7.13	Peak	100	95
13	251.10	49.42	-12.33	37.09	46.00	-8.91	Peak	100	144
14	260.73	46.66	-9.73	36.93	46.00	-9.07	Peak	100	122
15	300.00	50.95	-9.50	41.45	46.00	-4.55	QP	100	41

Notes:

1. Result = Read Value + Factor
2. Factor = Antenna Factor + Cable Loss - Amplifier
3. The resolution bandwidth of test receiver/spectrum analyzer is 120KHz and video bandwidth is 300kHz for Peak detection and Quasi-peak detection at frequency below 1GHz.
4. According to technical experiences, all spurious emission of 802.11MIMO mode at channel 3,6,9 are almost the same below 1GHz, so that the channel 3 was chosen as representative in final test.
5. The data is worse case.

Power	: AC 120V	Pol/Phase	: VERTICAL
Test Mode 1	: Transmit / Receive	Temperature	: 25 °C
Operation Channel	: 3	Humidity	: 65 %
Modulation Type	: 802.11n, HT40	Atmospheric Pressure	: 1020 hPa
Memo	: DSA-20P-10 US 120180	Rate	: 270Mbps

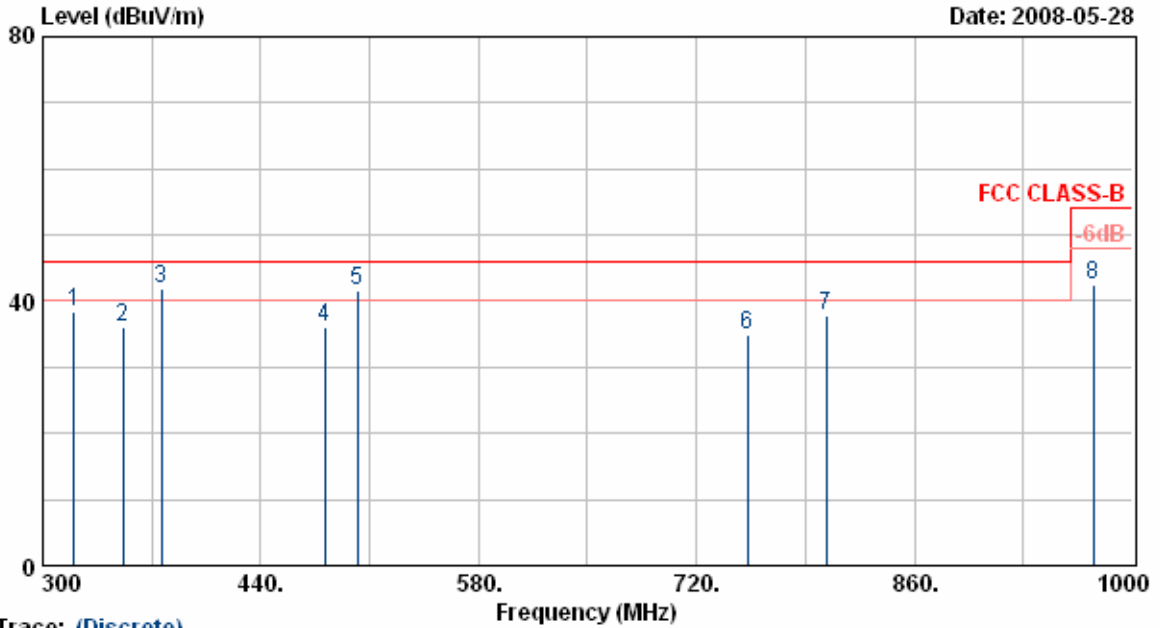

Trace: (Discrete)

Item	Freq	Read Value	Factor	Result	Limit	Margin	Remark	Ant Pos	Tab Pos
	MHz	dBuV/m	dB	dBuV/m	dBuV/m	dB		cm	Deg
1	320.30	48.90	-10.38	38.52	46.00	-7.48	Peak	100	74
2	351.80	46.66	-10.65	36.01	46.00	-9.99	Peak	100	105
3	376.30	51.16	-9.17	41.99	46.00	-4.01	QP	100	105
4	481.30	40.82	-4.66	36.16	46.00	-9.84	Peak	100	144
5	502.30	46.55	-4.95	41.60	46.00	-4.40	QP	100	201
6	752.90	34.66	0.38	35.04	46.00	-10.96	Peak	100	201
7	803.30	40.55	-2.76	37.79	46.00	-8.21	Peak	100	74
8	974.80	39.00	3.45	42.45	54.00	-11.55	Peak	100	122

Notes:

1. Result = Read Value + Factor
2. Factor = Antenna Factor + Cable Loss - Amplifier
3. The resolution bandwidth of test receiver/spectrum analyzer is 120KHz and video bandwidth is 300kHz for Peak detection and Quasi-peak detection at frequency below 1GHz.
4. According to technical experiences, all spurious emission of 802.11MIMO mode at channel 3,6,9 are almost the same below 1GHz, so that the channel 3 was chosen as representative in final test.
5. The data is worse case.

Power	: AC 120V	Pol/Phase	: HORIZONTAL
Test Mode 1	: Transmit / Receive	Temperature	: 25 °C
Operation Channel	: 3	Humidity	: 65 %
Modulation Type	: 802.11n, HT40	Atmospheric Pressure	: 1020 hPa
Memo	: DSA-20P-10 US 120180	Rate	: 270Mbps

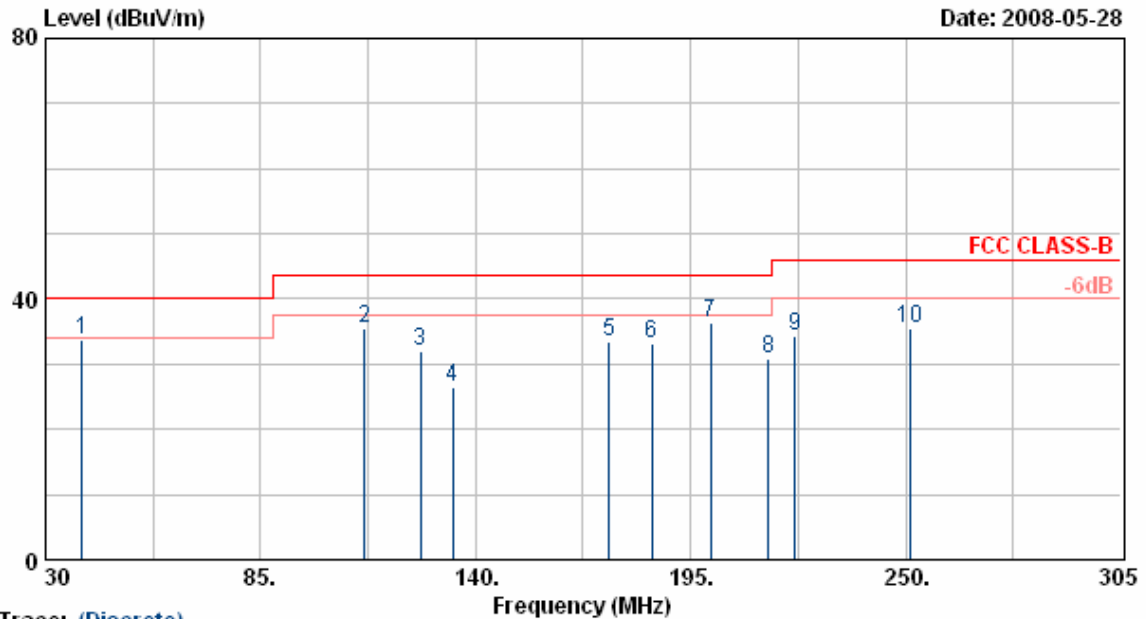

Trace: (Discrete)

Item	Freq	Read Value	Factor	Result	Limit	Margin	Remark	Ant Pos	Tab Pos
	MHz	dBuV/m	dB	dBuV/m	dBuV/m	dB		cm	Deg
1	39.35	48.50	-14.87	33.63	40.00	-6.37	Peak	200	45
2	111.70	54.85	-19.23	35.62	43.50	-7.88	Peak	200	147
3	125.98	51.52	-19.62	31.90	43.50	-11.60	Peak	200	152
4	134.23	45.78	-19.35	26.43	43.50	-17.07	Peak	200	222
5	174.10	51.53	-17.94	33.59	43.50	-9.91	Peak	200	188
6	185.10	50.99	-17.81	33.18	43.50	-10.32	Peak	200	28
7	200.01	50.96	-14.49	36.47	43.50	-7.03	Peak	200	222
8	215.00	49.22	-18.48	30.74	43.50	-12.76	Peak	200	87
9	221.70	52.52	-18.06	34.46	46.00	-11.54	Peak	200	157
10	251.10	52.83	-17.31	35.52	46.00	-10.48	Peak	200	255

Notes:

1. Result = Read Value + Factor
2. Factor = Antenna Factor + Cable Loss - Amplifier
3. The resolution bandwidth of test receiver/spectrum analyzer is 120KHz and video bandwidth is 300kHz for Peak detection and Quasi-peak detection at frequency below 1GHz.
4. According to technical experiences, all spurious emission of 802.11MIMO mode at channel 3,6,9 are almost the same below 1GHz, so that the channel 3 was chosen as representative in final test.
5. The data is worse case.

Power	: AC 120V	Pol/Phase	: HORIZONTAL
Test Mode 1	: Transmit / Receive	Temperature	: 25 °C
Operation Channel	: 3	Humidity	: 65 %
Modulation Type	: 802.11n, HT40	Atmospheric Pressure	: 1020 hPa
Memo	: DSA-20P-10 US 120180	Rate	: 270Mbps

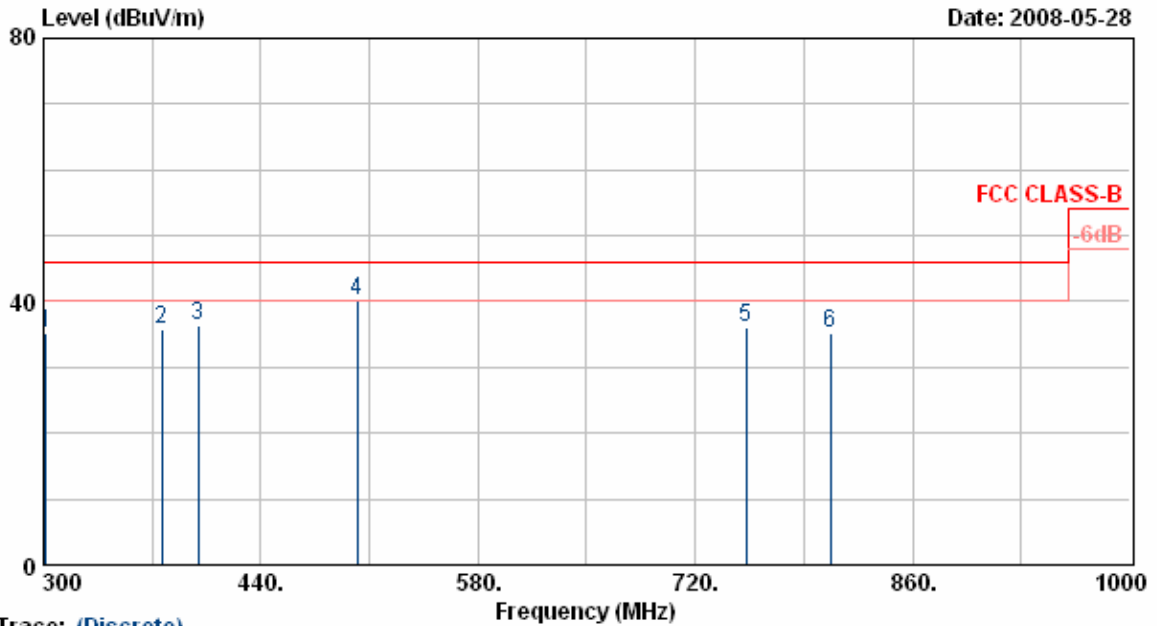

Trace: (Discrete)

Item	Freq	Read Value	Factor	Result	Limit	Margin	Remark	Ant Pos	Tab Pos
	MHz	dBuV/m	dB	dBuV/m	dBuV/m	dB		cm	Deg
1	301.40	49.66	-14.33	35.33	46.00	-10.67	Peak	200	333
2	376.30	46.55	-10.87	35.68	46.00	-10.32	Peak	200	99
3	399.40	47.32	-11.05	36.27	46.00	-9.73	Peak	200	232
4	502.30	45.28	-5.03	40.25	46.00	-5.75	QP	200	299
5	752.90	36.22	-0.03	36.19	46.00	-9.81	Peak	200	299
6	806.80	35.72	-0.43	35.29	46.00	-10.71	Peak	200	333

Notes:

1. Result = Read Value + Factor
2. Factor = Antenna Factor + Cable Loss - Amplifier
3. The resolution bandwidth of test receiver/spectrum analyzer is 120KHz and video bandwidth is 300kHz for Peak detection and Quasi-peak detection at frequency below 1GHz.
4. According to technical experiences, all spurious emission of 802.11MIMO mode at channel 3,6,9 are almost the same below 1GHz, so that the channel 3 was chosen as representative in final test.
5. The data is worse case.

Power	: AC 120V	Pol/Phase	: VERTICAL
Test Mode 1	: Transmit / Receive	Temperature	: 25 °C
Operation Channel	: 3	Humidity	: 65 %
Modulation Type	: 802.11n, HT40	Atmospheric Pressure	: 1020 hPa
Memo	: DSA-20P-10 US 120180	Rate	: 270Mbps

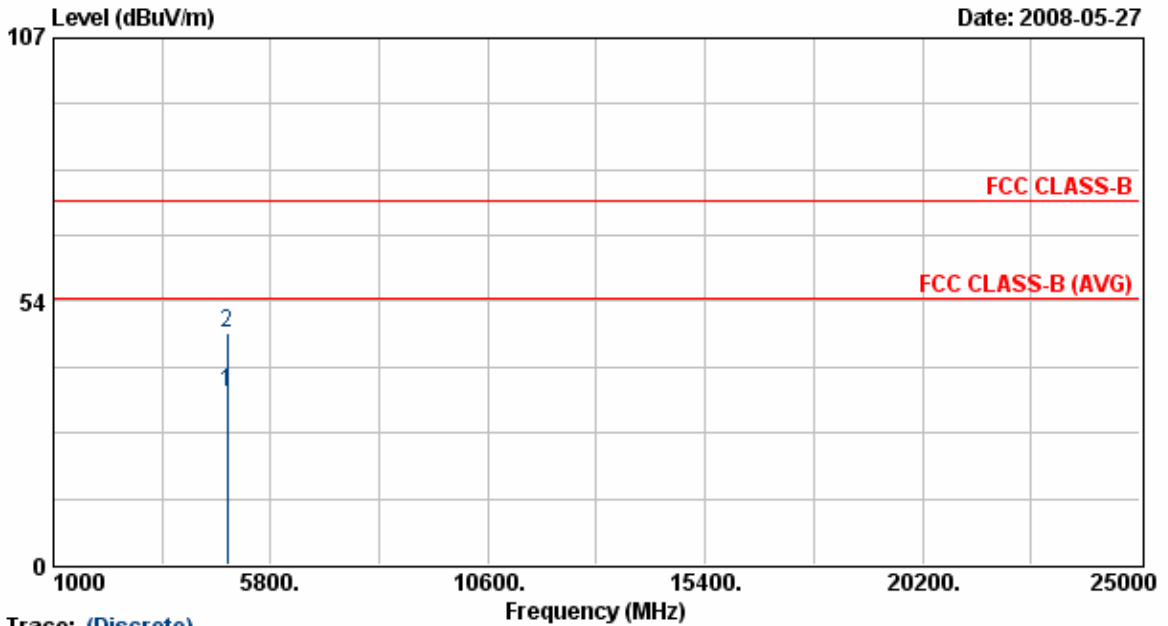

Trace: (Discrete)

Item	Freq	Read Value	Factor	Result	Limit	Margin	Remark	Ant Pos	Tab Pos
	MHz	dBuV/m	dB	dBuV/m	dBuV/m	dB		cm	Deg
1	4844.23	29.34	5.72	35.06	54.00	-18.94	Average	100	144
2	4844.23	41.27	5.72	46.99	74.00	-27.01	Peak	100	144

Notes:

1. Result = Read Value + Factor
2. Factor = Antenna Factor + Cable Loss - Amplifier
3. The resolution bandwidth of test receiver/spectrum analyzer is 120KHz and video bandwidth is 300kHz for Peak detection and Quasi-peak detection at frequency below 1GHz.
4. The resolution bandwidth of test receiver/spectrum analyzer is 1MHz and video bandwidth is 3MHz for Peak detection at frequency above 1GHz.
5. The resolution bandwidth of test receiver/spectrum analyzer is 1MHz and video bandwidth is 10Hz for Average detection at frequency above 1GHz.
6. The other emissions is too low to be measured.

Power	: AC 120V	Pol/Phase	: HORIZONTAL
Test Mode 1	: Transmit / Receive	Temperature	: 25 °C
Operation Channel	: 3	Humidity	: 65 %
Modulation Type	: 802.11n, HT40	Atmospheric Pressure	: 1020 hPa
Memo	: DSA-20P-10 US 120180	Rate	: 270Mbps

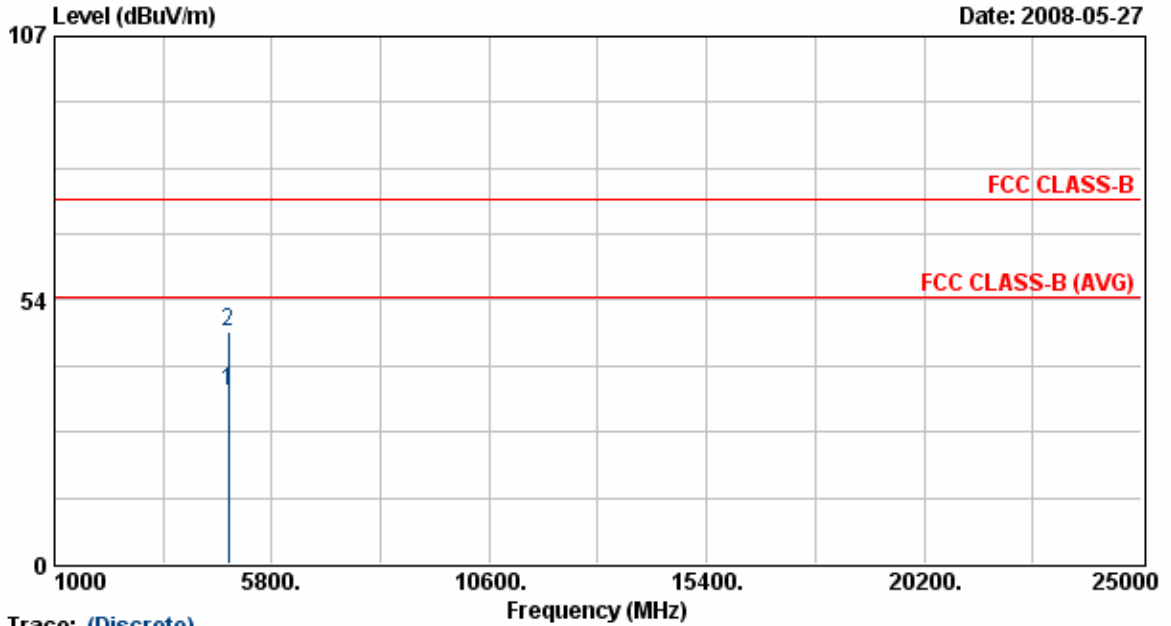

Trace: (Discrete)

Item	Freq	Read Value	Factor	Result	Limit	Margin	Remark	Ant Pos	Tab Pos
	MHz	dBuV/m	dB	dBuV/m	dBuV/m	dB		cm	Deg
1	4843.83	29.47	5.72	35.19	54.00	-18.81	Average	100	241
2	4843.83	41.17	5.72	46.89	74.00	-27.11	Peak	100	241

Notes:

1. Result = Read Value + Factor
2. Factor = Antenna Factor + Cable Loss - Amplifier
3. The resolution bandwidth of test receiver/spectrum analyzer is 120KHz and video bandwidth is 300kHz for Peak detection and Quasi-peak detection at frequency below 1GHz.
4. The resolution bandwidth of test receiver/spectrum analyzer is 1MHz and video bandwidth is 3MHz for Peak detection at frequency above 1GHz.
5. The resolution bandwidth of test receiver/spectrum analyzer is 1MHz and video bandwidth is 10Hz for Average detection at frequency above 1GHz.
6. The other emissions is too low to be measured.

Power	: AC 120V	Pol/Phase	: VERTICAL
Test Mode 1	: Transmit / Receive	Temperature	: 25 °C
Operation Channel	: 6	Humidity	: 65 %
Modulation Type	: 802.11n, HT40	Atmospheric Pressure	: 1020 hPa
Memo	: DSA-20P-10 US 120180	Rate	: 270Mbps

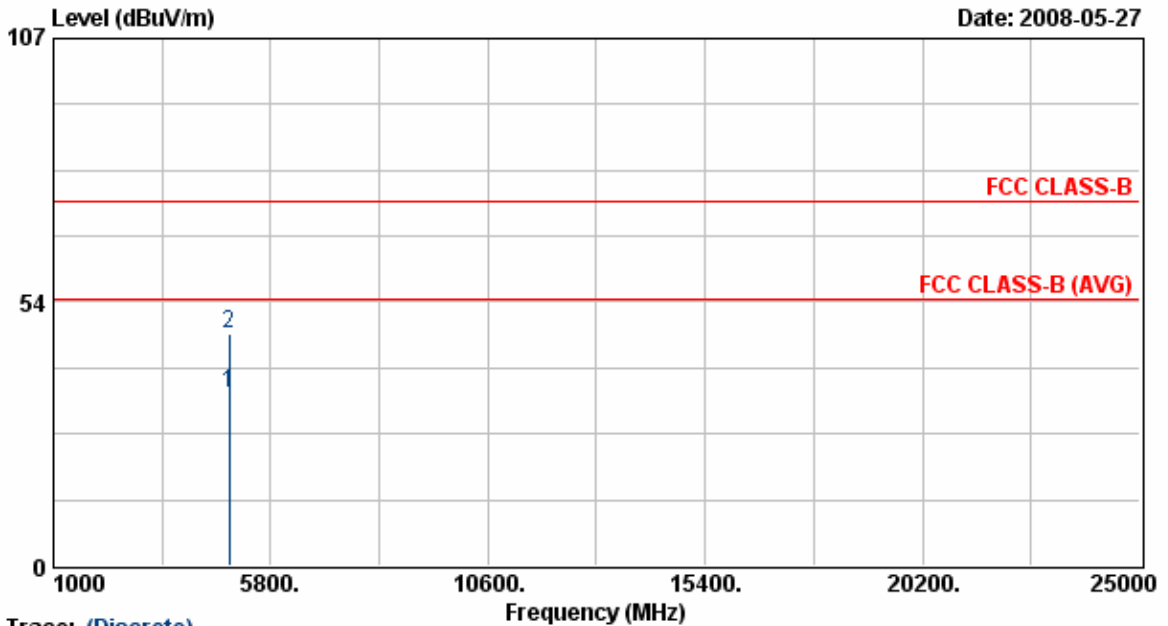

Trace: (Discrete)

Item	Freq	Read Value	Factor	Result	Limit	Margin	Remark	Ant Pos	Tab Pos
	MHz	dBuV/m	dB	dBuV/m	dBuV/m	dB		cm	Deg
1	4874.03	29.34	5.80	35.14	54.00	-18.86	Average	100	144
2	4874.03	41.13	5.80	46.93	74.00	-27.07	Peak	100	144

Notes:

1. Result = Read Value + Factor
2. Factor = Antenna Factor + Cable Loss - Amplifier
3. The resolution bandwidth of test receiver/spectrum analyzer is 120KHz and video bandwidth is 300kHz for Peak detection and Quasi-peak detection at frequency below 1GHz.
4. The resolution bandwidth of test receiver/spectrum analyzer is 1MHz and video bandwidth is 3MHz for Peak detection at frequency above 1GHz.
5. The resolution bandwidth of test receiver/spectrum analyzer is 1MHz and video bandwidth is 10Hz for Average detection at frequency above 1GHz.
6. The other emissions is too low to be measured.

Power	: AC 120V	Pol/Phase	: HORIZONTAL
Test Mode 1	: Transmit / Receive	Temperature	: 25 °C
Operation Channel	: 6	Humidity	: 65 %
Modulation Type	: 802.11n, HT40	Atmospheric Pressure	: 1020 hPa
Memo	: DSA-20P-10 US 120180	Rate	: 270Mbps

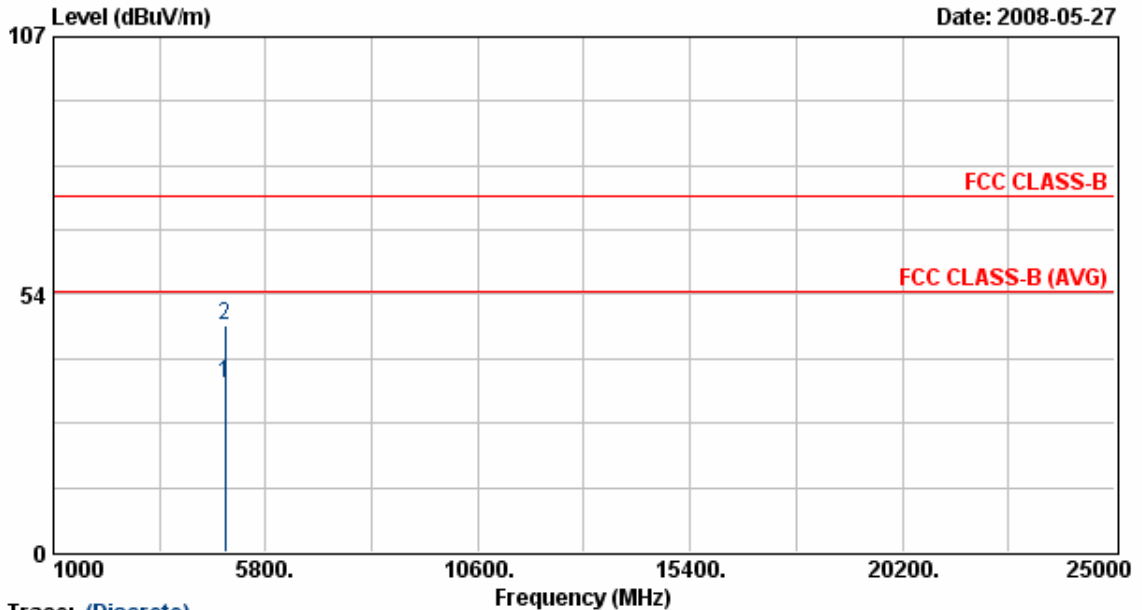

Trace: (Discrete)

Item	Freq	Read Value	Factor	Result	Limit	Margin	Remark	Ant Pos	Tab Pos
	MHz	dBuV/m	dB	dBuV/m	dBuV/m	dB		cm	Deg
1	4874.08	29.37	5.80	35.17	54.00	-18.83	Average	100	241
2	4874.08	41.19	5.80	46.99	74.00	-27.01	Peak	100	241

Notes:

1. Result = Read Value + Factor
2. Factor = Antenna Factor + Cable Loss - Amplifier
3. The resolution bandwidth of test receiver/spectrum analyzer is 120KHz and video bandwidth is 300kHz for Peak detection and Quasi-peak detection at frequency below 1GHz.
4. The resolution bandwidth of test receiver/spectrum analyzer is 1MHz and video bandwidth is 3MHz for Peak detection at frequency above 1GHz.
5. The resolution bandwidth of test receiver/spectrum analyzer is 1MHz and video bandwidth is 10Hz for Average detection at frequency above 1GHz.
6. The other emissions is too low to be measured.

Power	: AC 120V	Pol/Phase	: VERTICAL
Test Mode 1	: Transmit / Receive	Temperature	: 25 °C
Operation Channel	: 9	Humidity	: 65 %
Modulation Type	: 802.11n, HT40	Atmospheric Pressure	: 1020 hPa
Memo	: DSA-20P-10 US 120180	Rate	: 270Mbps

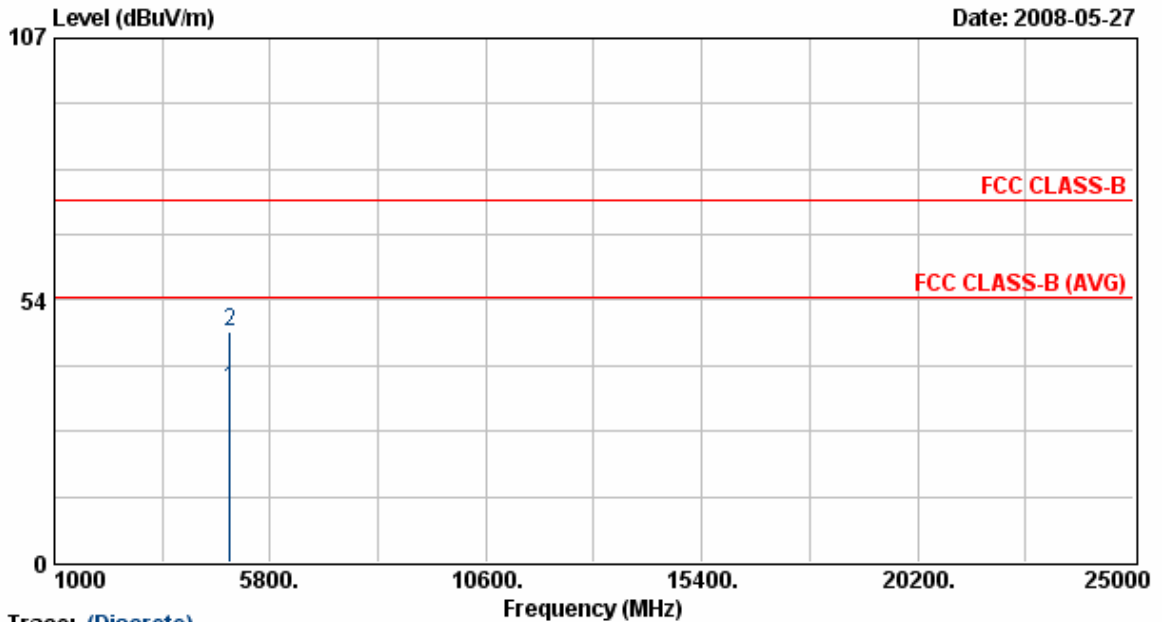

Trace: (Discrete)

Item	Freq	Read Value	Factor	Result	Limit	Margin	Remark	Ant Pos	Tab Pos
	MHz	dBuV/m	dB	dBuV/m	dBuV/m	dB		cm	Deg
1	4903.90	29.34	5.88	35.22	54.00	-18.78	Average	100	144
2	4903.90	41.29	5.88	47.17	74.00	-26.83	Peak	100	144

Notes:

1. Result = Read Value + Factor
2. Factor = Antenna Factor + Cable Loss - Amplifier
3. The resolution bandwidth of test receiver/spectrum analyzer is 120KHz and video bandwidth is 300kHz for Peak detection and Quasi-peak detection at frequency below 1GHz.
4. The resolution bandwidth of test receiver/spectrum analyzer is 1MHz and video bandwidth is 3MHz for Peak detection at frequency above 1GHz.
5. The resolution bandwidth of test receiver/spectrum analyzer is 1MHz and video bandwidth is 10Hz for Average detection at frequency above 1GHz.
6. The other emissions is too low to be measured.

Power	: AC 120V	Pol/Phase	: HORIZONTAL
Test Mode 1	: Transmit / Receive	Temperature	: 25 °C
Operation Channel	: 9	Humidity	: 65 %
Modulation Type	: 802.11n, HT40	Atmospheric Pressure	: 1020 hPa
Memo	: DSA-20P-10 US 120180	Rate	: 270Mbps

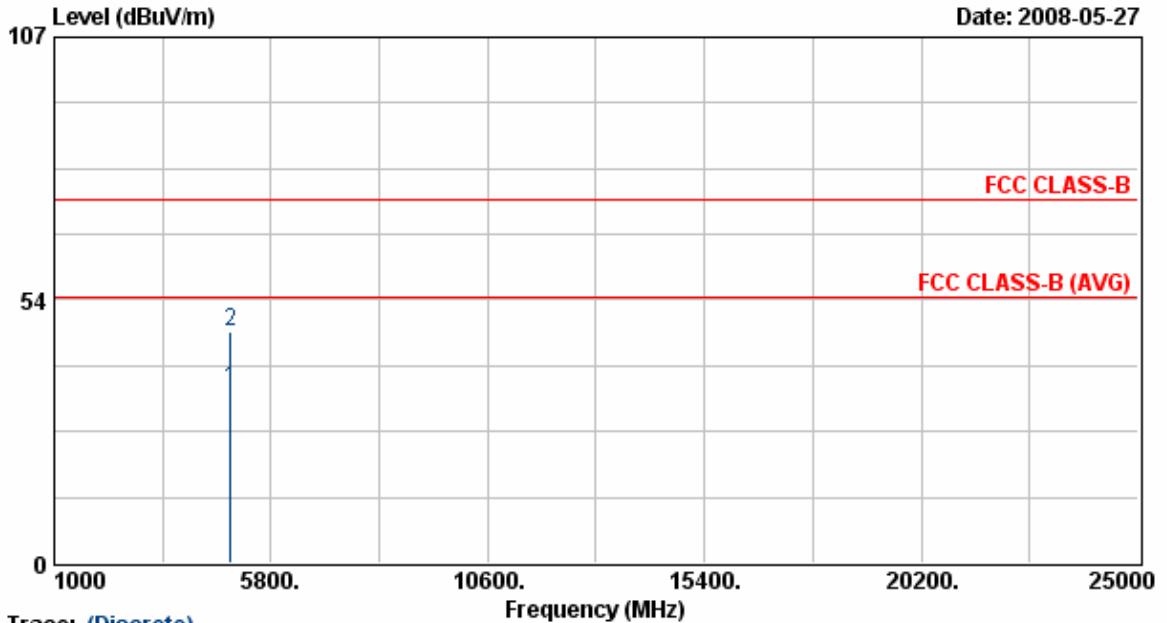

Trace: (Discrete)

Item	Freq	Read Value	Factor	Result	Limit	Margin	Remark	Ant Pos	Tab Pos
	MHz	dBuV/m	dB	dBuV/m	dBuV/m	dB		cm	Deg
1	4904.15	29.34	5.88	35.22	54.00	-18.78	Average	100	241
2	4904.15	41.21	5.88	47.09	74.00	-26.91	Peak	100	241

Notes:

1. Result = Read Value + Factor
2. Factor = Antenna Factor + Cable Loss - Amplifier
3. The resolution bandwidth of test receiver/spectrum analyzer is 120KHz and video bandwidth is 300kHz for Peak detection and Quasi-peak detection at frequency below 1GHz.
4. The resolution bandwidth of test receiver/spectrum analyzer is 1MHz and video bandwidth is 3MHz for Peak detection at frequency above 1GHz.
5. The resolution bandwidth of test receiver/spectrum analyzer is 1MHz and video bandwidth is 10Hz for Average detection at frequency above 1GHz.
6. The other emissions is too low to be measured.

Power	: AC 120V	Pol/Phase	: VERTICAL
Test Mode 2	: Transmit / Receive	Temperature	: 25 °C
Operation Channel	: 1	Humidity	: 65 %
Modulation Type	: 802.11g	Atmospheric Pressure	: 1020 hPa
Memo	: MU18-2120150-A1	Rate	: 54Mbps

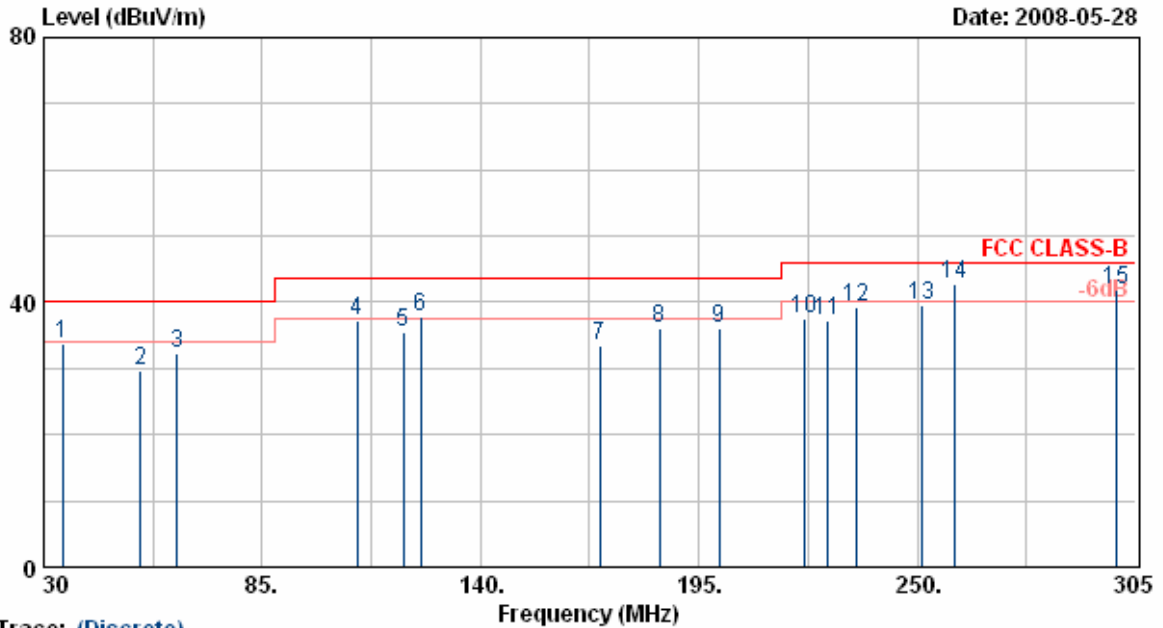

Trace: (Discrete)

Item	Freq	Read Value	Factor	Result	Limit	Margin	Remark	Ant Pos	Tab Pos
	MHz	dBuV/m	dB	dBuV/m	dBuV/m	dB		cm	Deg
1	34.68	41.85	-8.09	33.76	40.00	-6.24	Peak	100	98
2	54.48	45.70	-15.95	29.75	40.00	-10.25	Peak	100	155
3	63.55	50.80	-18.55	32.25	40.00	-7.75	Peak	100	155
4	108.85	50.79	-13.49	37.30	43.50	-6.20	Peak	100	162
5	120.48	48.99	-13.63	35.36	43.50	-8.14	Peak	100	182
6	125.03	50.99	-13.30	37.69	43.50	-5.81	QP	100	159
7	169.98	45.82	-12.38	33.44	43.50	-10.06	Peak	100	177
8	185.10	45.52	-9.56	35.96	43.50	-7.54	Peak	100	352
9	200.23	47.69	-11.71	35.98	43.50	-7.52	Peak	100	285
10	221.68	50.58	-13.10	37.48	46.00	-8.52	Peak	100	241
11	227.18	49.70	-12.42	37.28	46.00	-8.72	Peak	100	241
12	234.60	48.89	-9.75	39.14	46.00	-6.86	Peak	100	50
13	251.10	51.89	-12.33	39.56	46.00	-6.44	Peak	100	69
14	259.35	52.62	-9.97	42.65	46.00	-3.35	QP	100	88
15	300.04	51.50	-9.49	42.01	46.00	-3.99	QP	100	88

Notes:

1. Result = Read Value + Factor
2. Factor = Antenna Factor + Cable Loss - Amplifier
3. The resolution bandwidth of test receiver/spectrum analyzer is 120KHz and video bandwidth is 300kHz for Peak detection and Quasi-peak detection at frequency below 1GHz.
4. All emission below 1GHz at 802.11g mode are all the same, so the 802.11g mode chosen as representative in final test.
5. According to technical experiences, all spurious emission of 802.11g mode at channel 1,6,11 are almost the same below 1GHz, so that the channel 1 was chosen as representative in final test.
6. The data is worse case.

Power	: AC 120V	Pol/Phase	: VERTICAL
Test Mode 2	: Transmit / Receive	Temperature	: 25 °C
Operation Channel	: 1	Humidity	: 65 %
Modulation Type	: 802.11g	Atmospheric Pressure	: 1020 hPa
Memo	: MU18-2120150-A1	Rate	: 54Mbps

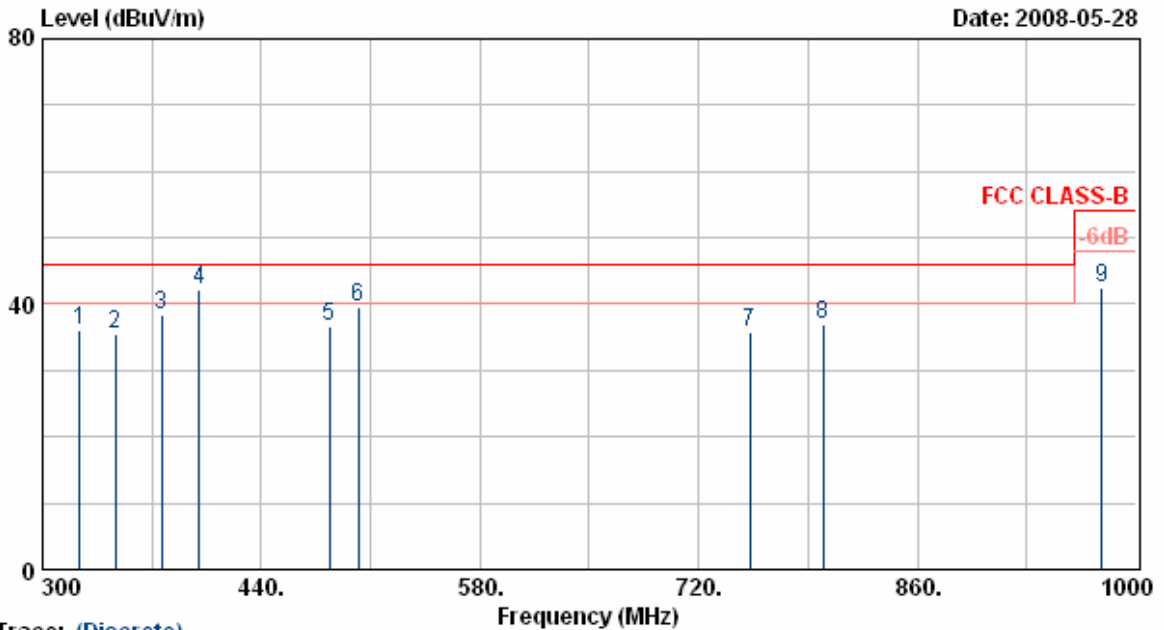

Trace: (Discrete)

Item	Freq MHz	Read Value dBUV/m	Factor dB	Result dBUV/m	Limit dBUV/m	Margin dB	Remark	Ant Pos cm	Tab Pos Deg
1	323.80	45.52	-9.42	36.10	46.00	-9.90	Peak	100	77
2	346.90	45.93	-10.31	35.62	46.00	-10.38	Peak	100	95
3	376.30	47.58	-9.17	38.41	46.00	-7.59	Peak	100	92
4	400.10	50.84	-8.80	42.04	46.00	-3.96	QP	100	185
5	483.40	41.68	-4.93	36.75	46.00	-9.25	Peak	100	222
6	502.30	44.58	-4.95	39.63	46.00	-6.37	Peak	100	241
7	752.90	35.50	0.38	35.88	46.00	-10.12	Peak	100	255
8	799.80	39.76	-2.83	36.93	46.00	-9.07	Peak	100	222
9	978.30	40.00	2.61	42.61	54.00	-11.39	Peak	100	222

Notes:

1. Result = Read Value + Factor
2. Factor = Antenna Factor + Cable Loss - Amplifier
3. The resolution bandwidth of test receiver/spectrum analyzer is 120KHz and video bandwidth is 300kHz for Peak detection and Quasi-peak detection at frequency below 1GHz.
4. All emission below 1GHz at 802.11b/g mode are all the same, so the 802.11g mode chosen as representative in final test.
5. According to technical experiences, all spurious emission of 802.11g mode at channel 1,6,11 are almost the same below 1GHz, so that the channel 1 was chosen as representative in final test.
6. The data is worse case.

Power	: AC 120V	Pol/Phase	: HORIZONTAL
Test Mode 2	: Transmit / Receive	Temperature	: 25 °C
Operation Channel	: 1	Humidity	: 65 %
Modulation Type	: 802.11g	Atmospheric Pressure	: 1020 hPa
Memo	: MU18-2120150-A1	Rate	: 54Mbps

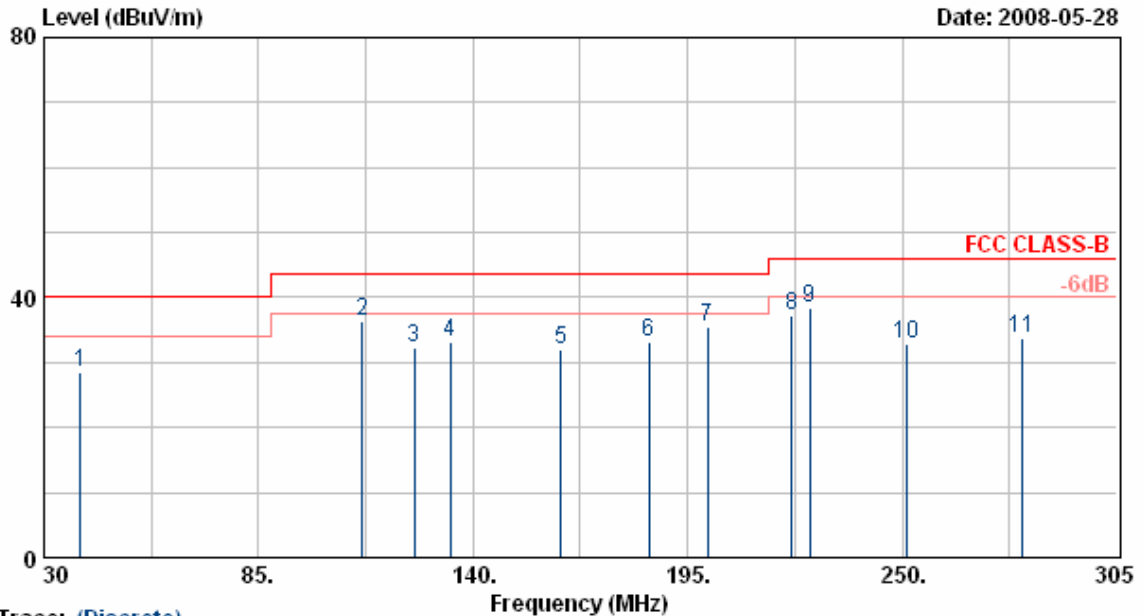

Trace: (Discrete)

Item	Freq	Read Value	Factor	Result	Limit	Margin	Remark	Ant Pos	Tab Pos
	MHz	dBuV/m	dB	dBuV/m	dBuV/m	dB		cm	Deg
1	39.35	43.49	-14.87	28.62	40.00	-11.38	Peak	200	48
2	111.70	55.58	-19.23	36.35	43.50	-7.15	Peak	200	144
3	125.04	51.81	-19.54	32.27	43.50	-11.23	Peak	200	144
4	134.23	52.59	-19.35	33.24	43.50	-10.26	Peak	200	187
5	162.55	50.59	-18.50	32.09	43.50	-11.41	Peak	200	197
6	185.10	50.88	-17.81	33.07	43.50	-10.43	Peak	200	169
7	200.23	49.97	-14.58	35.39	43.50	-8.11	Peak	200	198
8	221.70	55.16	-18.06	37.10	46.00	-8.90	Peak	200	245
9	226.35	56.50	-18.07	38.43	46.00	-7.57	Peak	200	245
10	251.10	50.10	-17.31	32.79	46.00	-13.21	Peak	200	48
11	280.80	48.00	-14.28	33.72	46.00	-12.28	Peak	200	245

Notes:

1. Result = Read Value + Factor
2. Factor = Antenna Factor + Cable Loss - Amplifier
3. The resolution bandwidth of test receiver/spectrum analyzer is 120KHz and video bandwidth is 300kHz for Peak detection and Quasi-peak detection at frequency below 1GHz.
4. All emission below 1GHz at 802.11b/g mode are all the same,so the 802.11g mode chosen as representative in final test.
5. According to technical experiences,all spurious emission of 802.11g mode at channel 1,6,11 are almost the same below 1GHz,so that the channel 1 was chosen as representative in final test.
6. The data is worse case.

Power	: AC 120V	Pol/Phase	: HORIZONTAL
Test Mode 2	: Transmit / Receive	Temperature	: 25 °C
Operation Channel	: 1	Humidity	: 65 %
Modulation Type	: 802.11g	Atmospheric Pressure	: 1020 hPa
Memo	: MU18-2120150-A1	Rate	: 54Mbps

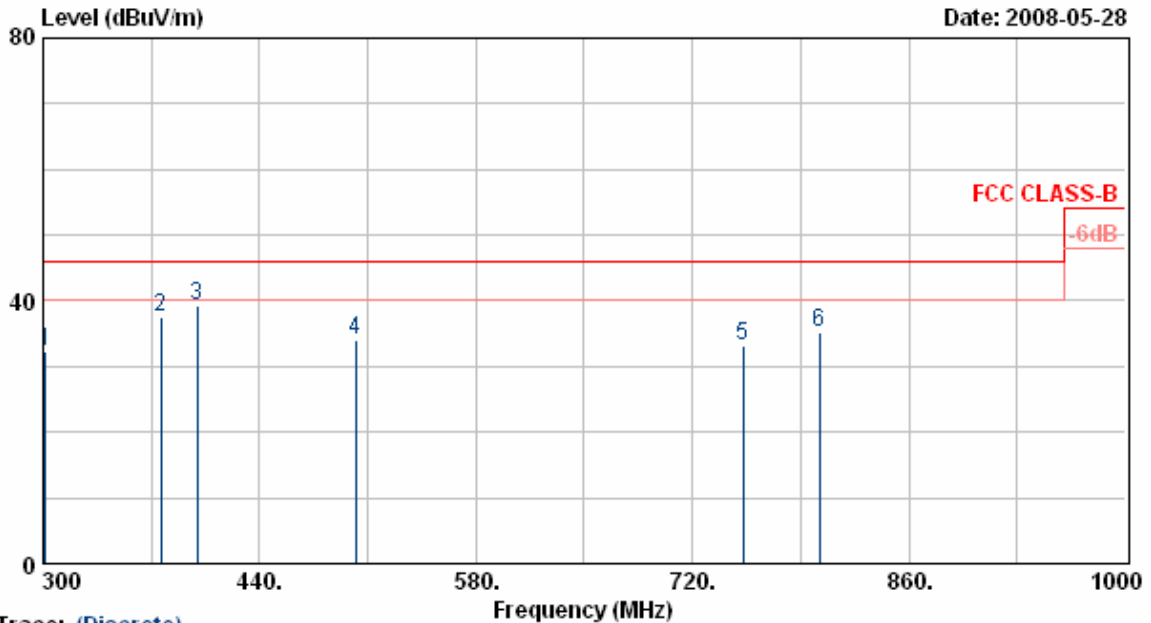

Trace: (Discrete)

Item	Freq	Read Value	Factor	Result	Limit	Margin	Remark	Ant Pos	Tab Pos
	MHz	dBUV/m	dB	dBUV/m	dBUV/m	dB		cm	Deg
1	301.40	46.58	-14.33	32.25	46.00	-13.75	Peak	200	47
2	376.30	48.51	-10.87	37.64	46.00	-8.36	Peak	200	54
3	399.40	50.23	-11.05	39.18	46.00	-6.82	Peak	200	54
4	502.30	38.95	-5.03	33.92	46.00	-12.08	Peak	200	88
5	752.90	33.22	-0.03	33.19	46.00	-12.81	Peak	200	155
6	801.90	35.66	-0.40	35.26	46.00	-10.74	Peak	200	111

Notes:

1. Result = Read Value + Factor
2. Factor = Antenna Factor + Cable Loss - Amplifier
3. The resolution bandwidth of test receiver/spectrum analyzer is 120KHz and video bandwidth is 300kHz for Peak detection and Quasi-peak detection at frequency below 1GHz.
4. All emission below 1GHz at 802.11b/g mode are all the same,so the 802.11g mode chosen as representative in final test.
5. According to technical experiences,all spurious emission of 802.11g mode at channel 1,6,11 are almost the same below 1GHz,so that the channel 1 was chosen as representative in final test.
6. The data is worse case.

Power	: AC 120V	Pol/Phase	: VERTICAL
Test Mode 2	: Transmit / Receive	Temperature	: 25 °C
Operation Channel	: 1	Humidity	: 65 %
Modulation Type	: 802.11b	Atmospheric Pressure	: 1020 hPa
Memo	: MU18-2120150-A1	Rate	: 11Mbps

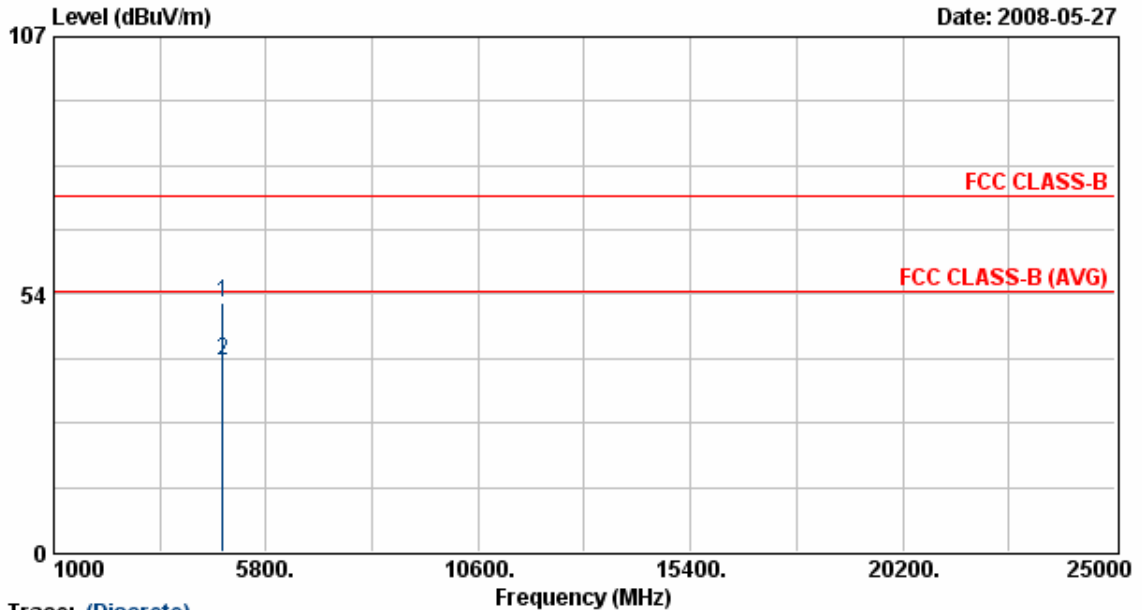

Trace: (Discrete)

Item	Freq	Read Value	Factor	Result	Limit	Margin	Remark	Ant Pos	Tab Pos
	MHz	dBuV/m	dB	dBuV/m	dBuV/m	dB		cm	Deg
1	4823.85	45.91	5.67	51.58	74.00	-22.42	Peak	100	144
2	4823.85	34.05	5.67	39.72	54.00	-14.28	Average	100	144

Notes:

1. Result = Read Value + Factor
2. Factor = Antenna Factor + Cable Loss - Amplifier
3. The resolution bandwidth of test receiver/spectrum analyzer is 120KHz and video bandwidth is 300kHz for Peak detection and Quasi-peak detection at frequency below 1GHz.
4. The resolution bandwidth of test receiver/spectrum analyzer is 1MHz and video bandwidth is 3MHz for Peak detection at frequency above 1GHz.
5. The resolution bandwidth of test receiver/spectrum analyzer is 1MHz and video bandwidth is 10Hz for Average detection at frequency above 1GHz.
6. The other emissions is too low to be measured.

Power	: AC 120V	Pol/Phase	: HORIZONTAL
Test Mode 2	: Transmit / Receive	Temperature	: 25 °C
Operation Channel	: 1	Humidity	: 65 %
Modulation Type	: 802.11b	Atmospheric Pressure	: 1020 hPa
Memo	: MU18-2120150-A1	Rate	: 11Mbps

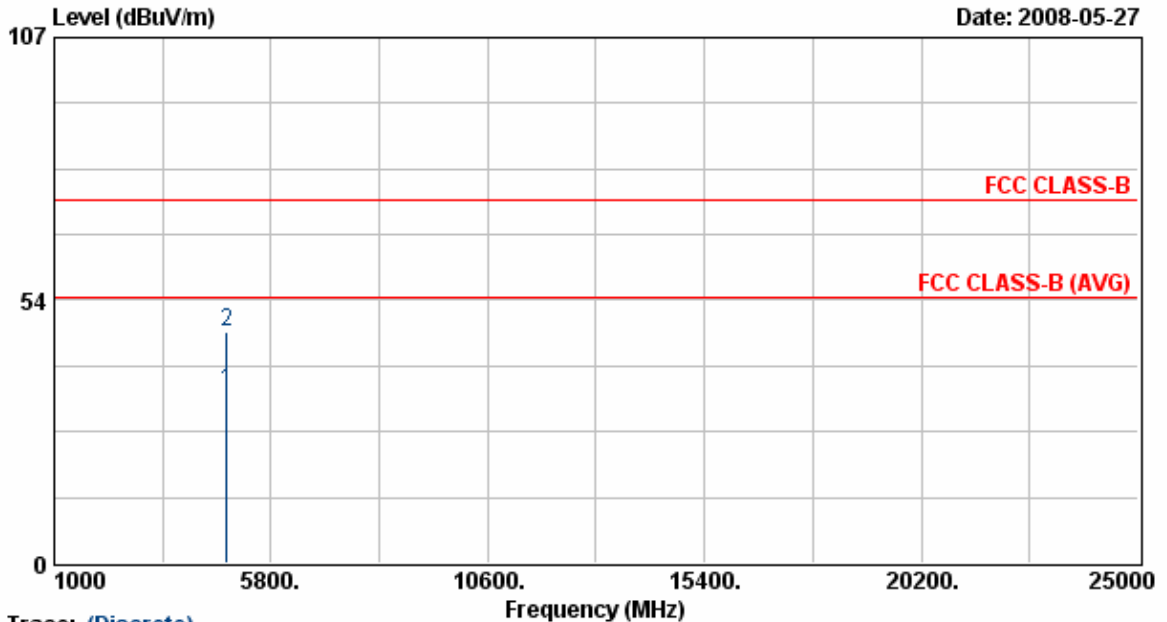

Trace: (Discrete)

Item	Freq	Read Value	Factor	Result	Limit	Margin	Remark	Ant Pos	Tab Pos
	MHz	dBuV/m	dB	dBuV/m	dBuV/m	dB		cm	Deg
1	4823.88	29.45	5.67	35.12	54.00	-18.88	Average	100	241
2	4823.88	41.39	5.67	47.06	74.00	-26.94	Peak	100	241

Notes:

1. Result = Read Value + Factor
2. Factor = Antenna Factor + Cable Loss - Amplifier
3. The resolution bandwidth of test receiver/spectrum analyzer is 120KHz and video bandwidth is 300kHz for Peak detection and Quasi-peak detection at frequency below 1GHz.
4. The resolution bandwidth of test receiver/spectrum analyzer is 1MHz and video bandwidth is 3MHz for Peak detection at frequency above 1GHz.
5. The resolution bandwidth of test receiver/spectrum analyzer is 1MHz and video bandwidth is 10Hz for Average detection at frequency above 1GHz.
6. The other emissions is too low to be measured.

Power	: AC 120V	Pol/Phase	: VERTICAL
Test Mode 2	: Transmit / Receive	Temperature	: 25 °C
Operation Channel	: 6	Humidity	: 65 %
Modulation Type	: 802.11b	Atmospheric Pressure	: 1020 hPa
Memo	: MU18-2120150-A1	Rate	: 11Mbps

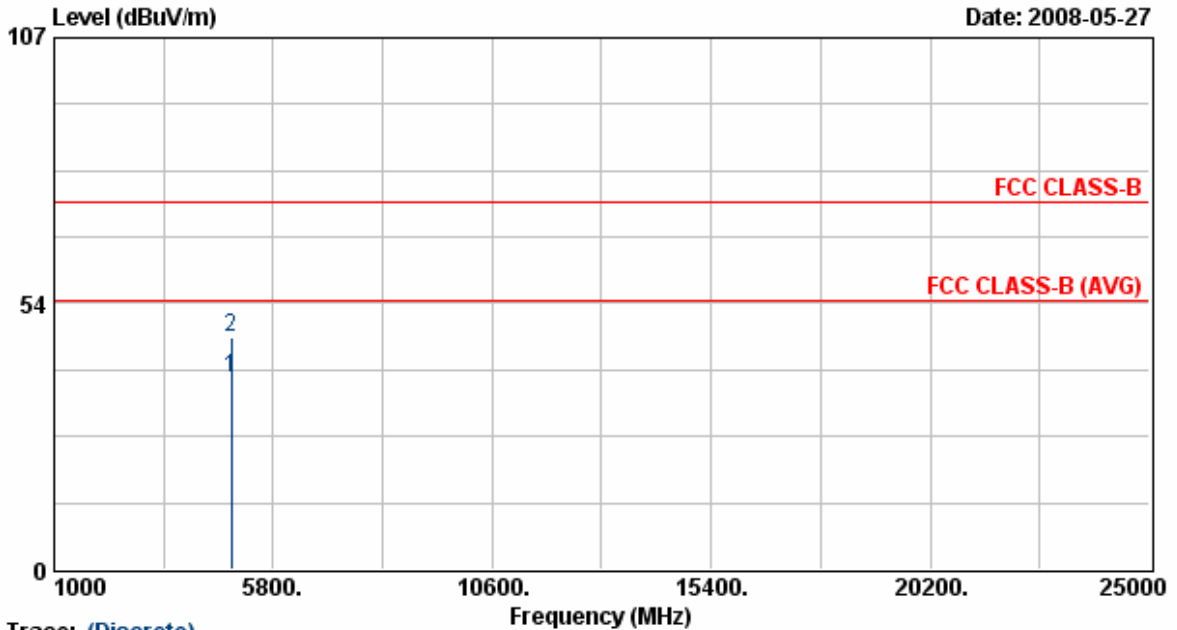

Trace: (Discrete)

Item	Freq	Read Value	Factor	Result	Limit	Margin	Remark	Ant Pos	Tab Pos
	MHz	dBuV/m	dB	dBuV/m	dBuV/m	dB		cm	Deg
1	4873.98	32.53	5.80	38.33	54.00	-15.67	Average	100	144
2	4873.98	40.90	5.80	46.70	74.00	-27.30	Peak	100	144

Notes:

1. Result = Read Value + Factor
2. Factor = Antenna Factor + Cable Loss - Amplifier
3. The resolution bandwidth of test receiver/spectrum analyzer is 120KHz and video bandwidth is 300kHz for Peak detection and Quasi-peak detection at frequency below 1GHz.
4. The resolution bandwidth of test receiver/spectrum analyzer is 1MHz and video bandwidth is 3MHz for Peak detection at frequency above 1GHz.
5. The resolution bandwidth of test receiver/spectrum analyzer is 1MHz and video bandwidth is 10Hz for Average detection at frequency above 1GHz.
6. The other emissions is too low to be measured.

Power	: AC 120V	Pol/Phase	: HORIZONTAL
Test Mode 2	: Transmit / Receive	Temperature	: 25 °C
Operation Channel	: 6	Humidity	: 65 %
Modulation Type	: 802.11b	Atmospheric Pressure	: 1020 hPa
Memo	: MU18-2120150-A1	Rate	: 11Mbps

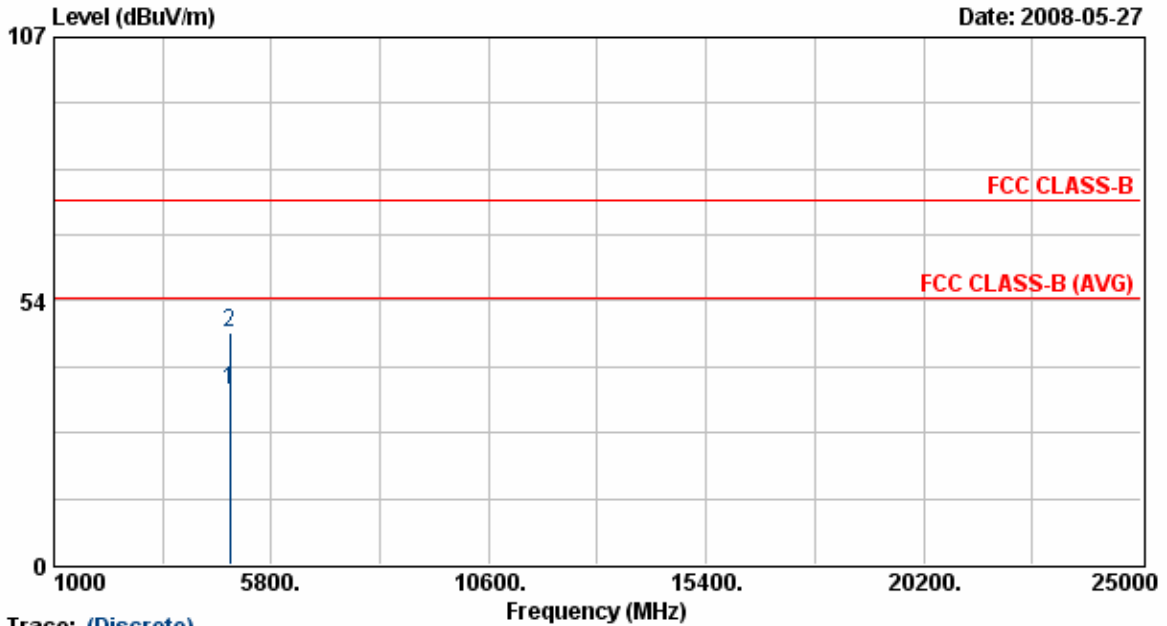

Trace: (Discrete)

Item	Freq	Read Value	Factor	Result	Limit	Margin	Remark	Ant Pos	Tab Pos
	MHz	dBuV/m	dB	dBuV/m	dBuV/m	dB		cm	Deg
1	4874.03	29.56	5.80	35.36	54.00	-18.64	Average	100	241
2	4874.03	41.43	5.80	47.23	74.00	-26.77	Peak	100	241

Notes:

1. Result = Read Value + Factor
2. Factor = Antenna Factor + Cable Loss - Amplifier
3. The resolution bandwidth of test receiver/spectrum analyzer is 120KHz and video bandwidth is 300kHz for Peak detection and Quasi-peak detection at frequency below 1GHz.
4. The resolution bandwidth of test receiver/spectrum analyzer is 1MHz and video bandwidth is 3MHz for Peak detection at frequency above 1GHz.
5. The resolution bandwidth of test receiver/spectrum analyzer is 1MHz and video bandwidth is 10Hz for Average detection at frequency above 1GHz.
6. The other emissions is too low to be measured.

Power	: AC 120V	Pol/Phase	: VERTICAL
Test Mode 2	: Transmit / Receive	Temperature	: 25 °C
Operation Channel	: 11	Humidity	: 65 %
Modulation Type	: 802.11b	Atmospheric Pressure	: 1020 hPa
Memo	: MU18-2120150-A1	Rate	: 11Mbps

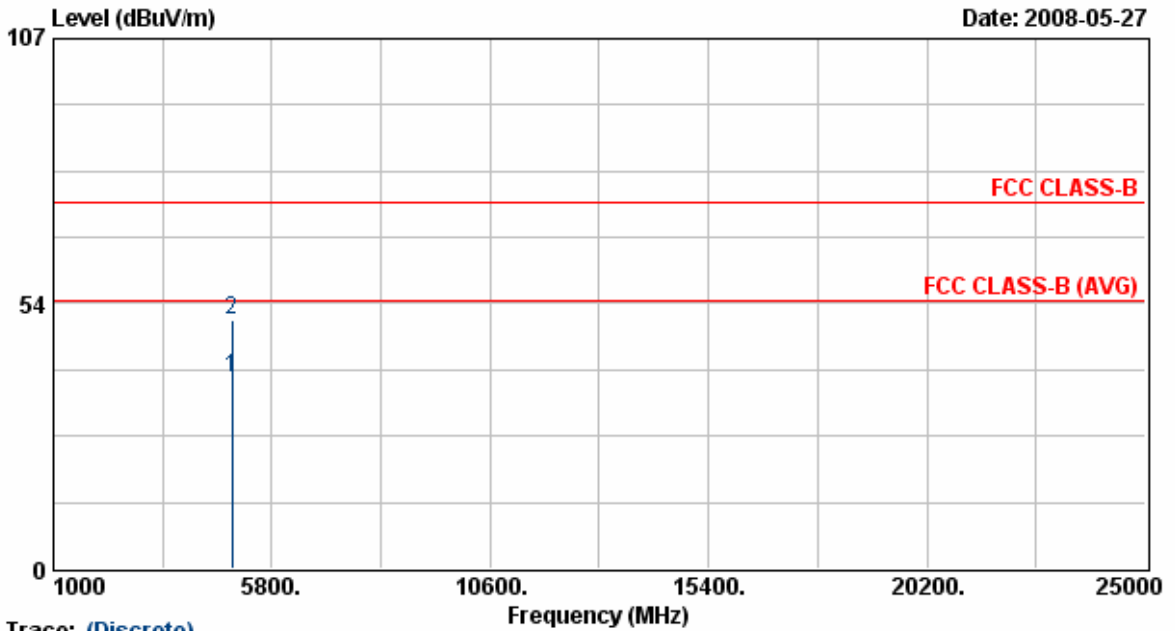

Trace: (Discrete)

Item	Freq	Read Value	Factor	Result	Limit	Margin	Remark	Ant Pos	Tab Pos
	MHz	dBuV/m	dB	dBuV/m	dBuV/m	dB		cm	Deg
1	4923.98	32.66	5.93	38.59	54.00	-15.41	Average	100	144
2	4923.98	44.42	5.93	50.35	74.00	-23.65	Peak	100	144

Notes:

1. Result = Read Value + Factor
2. Factor = Antenna Factor + Cable Loss - Amplifier
3. The resolution bandwidth of test receiver/spectrum analyzer is 120KHz and video bandwidth is 300kHz for Peak detection and Quasi-peak detection at frequency below 1GHz.
4. The resolution bandwidth of test receiver/spectrum analyzer is 1MHz and video bandwidth is 3MHz for Peak detection at frequency above 1GHz.
5. The resolution bandwidth of test receiver/spectrum analyzer is 1MHz and video bandwidth is 10Hz for Average detection at frequency above 1GHz.
6. The other emissions is too low to be measured.

Power	: AC 120V	Pol/Phase	: HORIZONTAL
Test Mode 2	: Transmit / Receive	Temperature	: 25 °C
Operation Channel	: 11	Humidity	: 65 %
Modulation Type	: 802.11b	Atmospheric Pressure	: 1020 hPa
Memo	: MU18-2120150-A1	Rate	: 11Mbps

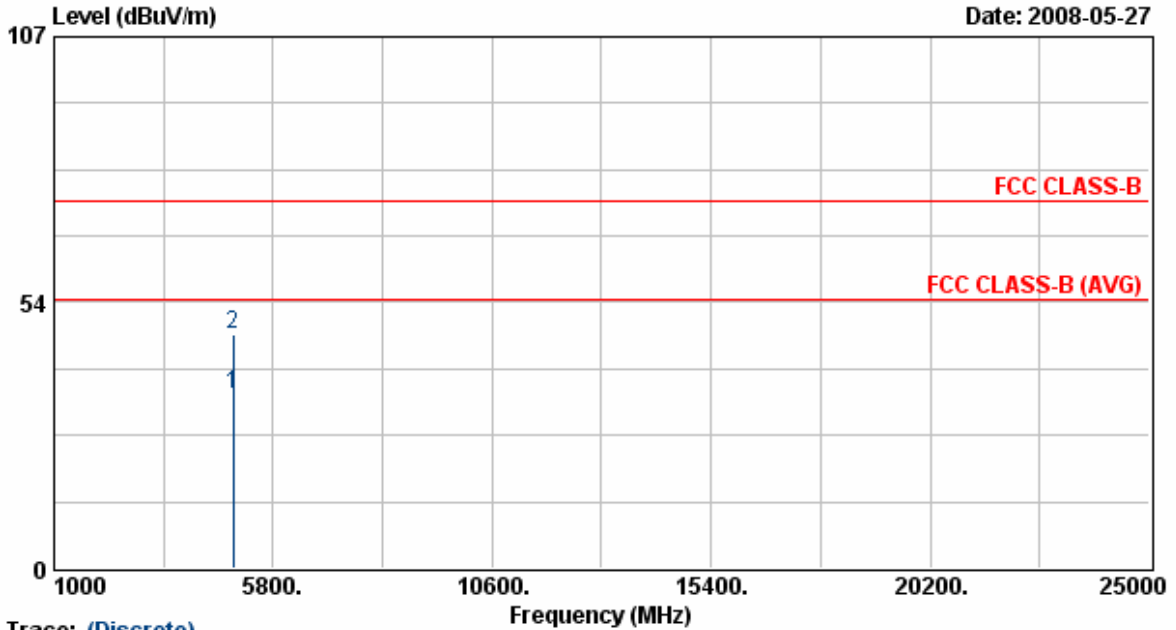

Trace: (Discrete)

Item	Freq	Read Value	Factor	Result	Limit	Margin	Remark	Ant Pos	Tab Pos
	MHz	dBuV/m	dB	dBuV/m	dBuV/m	dB		cm	Deg
1	4923.73	29.22	5.93	35.15	54.00	-18.85	Average	100	241
2	4923.73	41.09	5.93	47.02	74.00	-26.98	Peak	100	241

Notes:

1. Result = Read Value + Factor
2. Factor = Antenna Factor + Cable Loss - Amplifier
3. The resolution bandwidth of test receiver/spectrum analyzer is 120KHz and video bandwidth is 300kHz for Peak detection and Quasi-peak detection at frequency below 1GHz.
4. The resolution bandwidth of test receiver/spectrum analyzer is 1MHz and video bandwidth is 3MHz for Peak detection at frequency above 1GHz.
5. The resolution bandwidth of test receiver/spectrum analyzer is 1MHz and video bandwidth is 10Hz for Average detection at frequency above 1GHz.
6. The other emissions is too low to be measured.

Power	: AC 120V	Pol/Phase	: VERTICAL
Test Mode 2	: Transmit / Receive	Temperature	: 25 °C
Operation Channel	: 1	Humidity	: 65 %
Modulation Type	: 802.11g	Atmospheric Pressure	: 1020 hPa
Memo	: MU18-2120150-A1	Rate	: 54Mbps

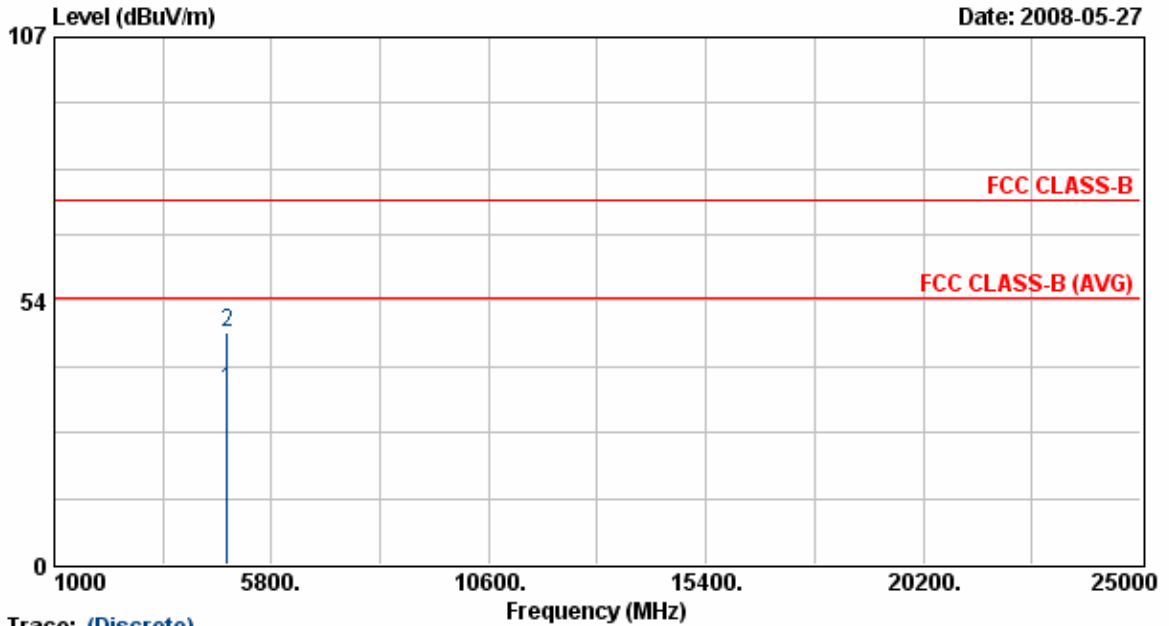

Trace: (Discrete)

Item	Freq	Read Value	Factor	Result	Limit	Margin	Remark	Ant Pos	Tab Pos
	MHz	dBuV/m	dB	dBuV/m	dBuV/m	dB		cm	Deg
1	4823.78	29.67	5.67	35.34	54.00	-18.66	Average	100	144
2	4823.78	41.57	5.67	47.24	74.00	-26.76	Peak	100	144

Notes:

1. Result = Read Value + Factor
2. Factor = Antenna Factor + Cable Loss - Amplifier
3. The resolution bandwidth of test receiver/spectrum analyzer is 120KHz and video bandwidth is 300kHz for Peak detection and Quasi-peak detection at frequency below 1GHz.
4. The resolution bandwidth of test receiver/spectrum analyzer is 1MHz and video bandwidth is 3MHz for Peak detection at frequency above 1GHz.
5. The resolution bandwidth of test receiver/spectrum analyzer is 1MHz and video bandwidth is 10Hz for Average detection at frequency above 1GHz.
6. The other emissions is too low to be measured.

Power	: AC 120V	Pol/Phase	: HORIZONTAL
Test Mode 2	: Transmit / Receive	Temperature	: 25 °C
Operation Channel	: 1	Humidity	: 65 %
Modulation Type	: 802.11g	Atmospheric Pressure	: 1020 hPa
Memo	: MU18-2120150-A1	Rate	: 54Mbps

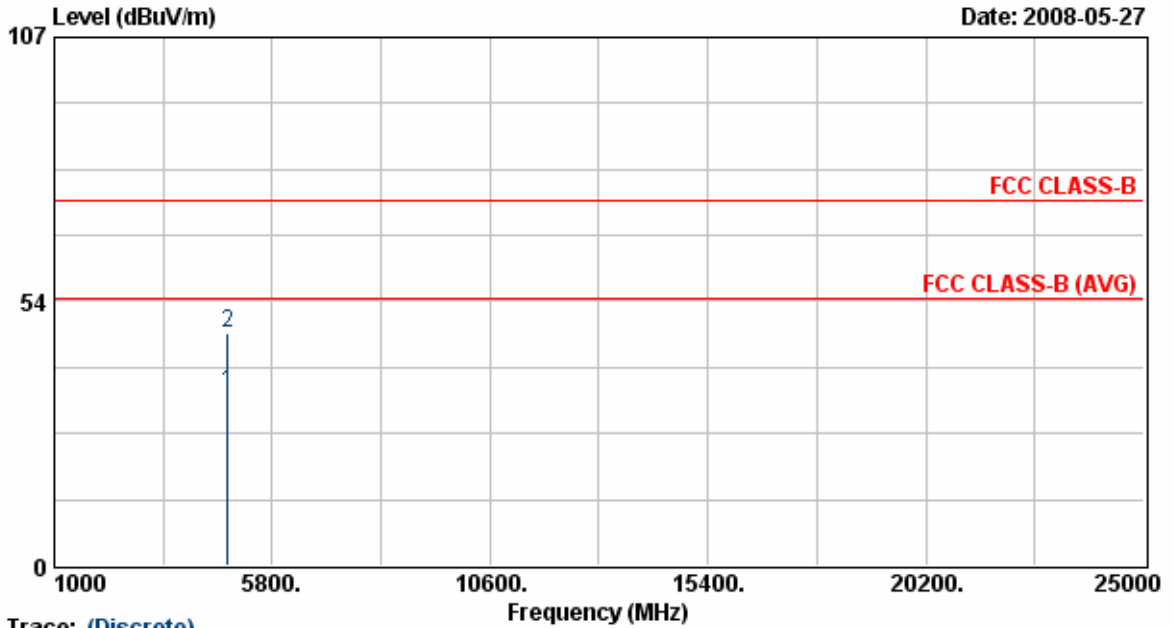

Trace: (Discrete)

Item	Freq	Read Value	Factor	Result	Limit	Margin	Remark	Ant Pos	Tab Pos
	MHz	dBuV/m	dB	dBuV/m	dBuV/m	dB		cm	Deg
1	4824.00	29.36	5.67	35.04	54.00	-18.96	Average	100	241
2	4824.00	41.26	5.67	46.94	74.00	-27.06	Peak	100	241

Notes:

1. Result = Read Value + Factor
2. Factor = Antenna Factor + Cable Loss - Amplifier
3. The resolution bandwidth of test receiver/spectrum analyzer is 120KHz and video bandwidth is 300kHz for Peak detection and Quasi-peak detection at frequency below 1GHz.
4. The resolution bandwidth of test receiver/spectrum analyzer is 1MHz and video bandwidth is 3MHz for Peak detection at frequency above 1GHz.
5. The resolution bandwidth of test receiver/spectrum analyzer is 1MHz and video bandwidth is 10Hz for Average detection at frequency above 1GHz.
6. The other emissions is too low to be measured.

Power	: AC 120V	Pol/Phase	: VERTICAL
Test Mode 2	: Transmit / Receive	Temperature	: 25 °C
Operation Channel	: 6	Humidity	: 65 %
Modulation Type	: 802.11g	Atmospheric Pressure	: 1020 hPa
Memo	: MU18-2120150-A1	Rate	: 54Mbps

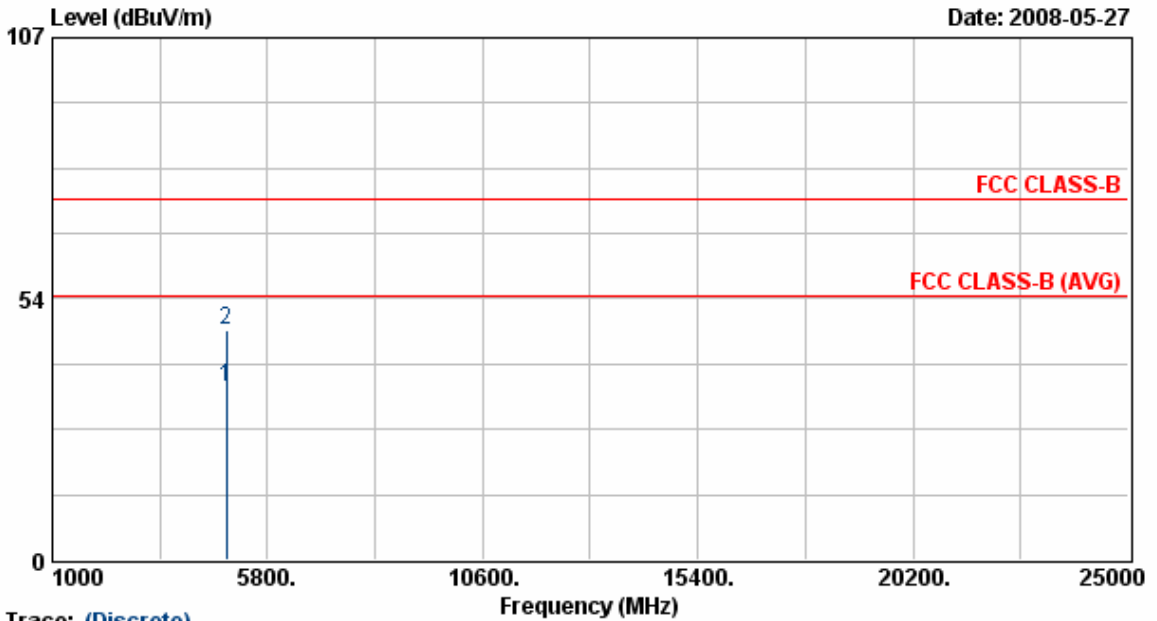

Trace: (Discrete)

Item	Freq	Read Value	Factor	Result	Limit	Margin	Remark	Ant Pos	Tab Pos
	MHz	dBuV/m	dB	dBuV/m	dBuV/m	dB		cm	Deg
1	4873.78	29.77	5.80	35.57	54.00	-18.43	Average	100	144
2	4873.78	41.41	5.80	47.21	74.00	-26.79	Peak	100	144

Notes:

1. Result = Read Value + Factor
2. Factor = Antenna Factor + Cable Loss - Amplifier
3. The resolution bandwidth of test receiver/spectrum analyzer is 120KHz and video bandwidth is 300kHz for Peak detection and Quasi-peak detection at frequency below 1GHz.
4. The resolution bandwidth of test receiver/spectrum analyzer is 1MHz and video bandwidth is 3MHz for Peak detection at frequency above 1GHz.
5. The resolution bandwidth of test receiver/spectrum analyzer is 1MHz and video bandwidth is 10Hz for Average detection at frequency above 1GHz.
6. The other emissions is too low to be measured.

Power	: AC 120V	Pol/Phase	: HORIZONTAL
Test Mode 2	: Transmit / Receive	Temperature	: 25 °C
Operation Channel	: 6	Humidity	: 65 %
Modulation Type	: 802.11g	Atmospheric Pressure	: 1020 hPa
Memo	: MU18-2120150-A1	Rate	: 54Mbps

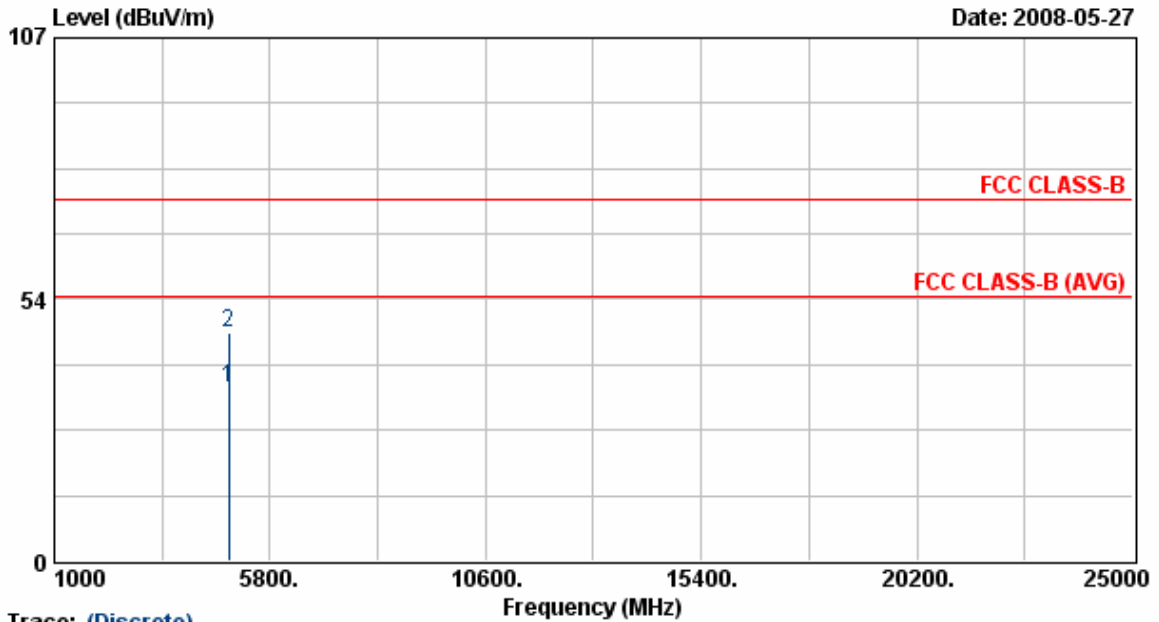

Trace: (Discrete)

Item	Freq	Read Value	Factor	Result	Limit	Margin	Remark	Ant Pos	Tab Pos
	MHz	dBUV/m	dB	dBUV/m	dBUV/m	dB		cm	Deg
1	4874.03	29.57	5.80	35.37	54.00	-18.63	Average	100	241
2	4874.03	41.05	5.80	46.85	74.00	-27.15	Peak	100	241

Notes:

1. Result = Read Value + Factor
2. Factor = Antenna Factor + Cable Loss - Amplifier
3. The resolution bandwidth of test receiver/spectrum analyzer is 120KHz and video bandwidth is 300kHz for Peak detection and Quasi-peak detection at frequency below 1GHz.
4. The resolution bandwidth of test receiver/spectrum analyzer is 1MHz and video bandwidth is 3MHz for Peak detection at frequency above 1GHz.
5. The resolution bandwidth of test receiver/spectrum analyzer is 1MHz and video bandwidth is 10Hz for Average detection at frequency above 1GHz.
6. The other emissions is too low to be measured.

Power	: AC 120V	Pol/Phase	: VERTICAL
Test Mode 2	: Transmit / Receive	Temperature	: 25 °C
Operation Channel	: 11	Humidity	: 65 %
Modulation Type	: 802.11g	Atmospheric Pressure	: 1020 hPa
Memo	: MU18-2120150-A1	Rate	: 54Mbps

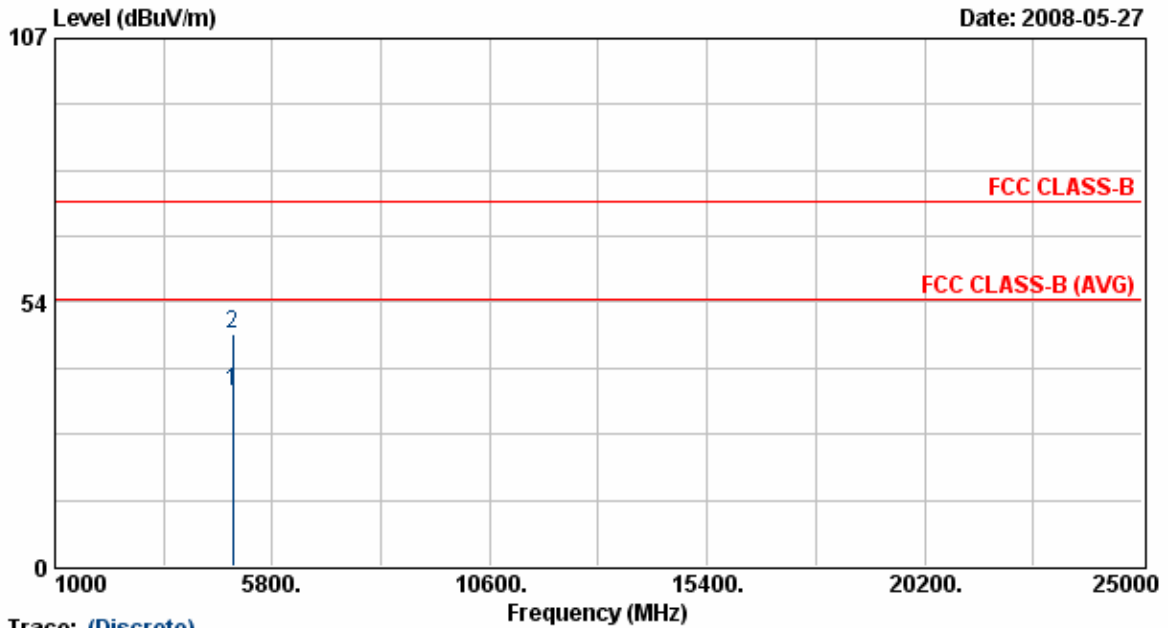

Trace: (Discrete)

Item	Freq	Read Value	Factor	Result	Limit	Margin	Remark	Ant Pos	Tab Pos
	MHz	dBuV/m	dB	dBuV/m	dBuV/m	dB		cm	Deg
1	4924.00	29.57	5.93	35.50	54.00	-18.50	Average	100	144
2	4924.00	41.34	5.93	47.27	74.00	-26.73	Peak	100	144

Notes:

1. Result = Read Value + Factor
2. Factor = Antenna Factor + Cable Loss - Amplifier
3. The resolution bandwidth of test receiver/spectrum analyzer is 120KHz and video bandwidth is 300kHz for Peak detection and Quasi-peak detection at frequency below 1GHz.
4. The resolution bandwidth of test receiver/spectrum analyzer is 1MHz and video bandwidth is 3MHz for Peak detection at frequency above 1GHz.
5. The resolution bandwidth of test receiver/spectrum analyzer is 1MHz and video bandwidth is 10Hz for Average detection at frequency above 1GHz.
6. The other emissions is too low to be measured.

Power	: AC 120V	Pol/Phase	: HORIZONTAL
Test Mode 2	: Transmit / Receive	Temperature	: 25 °C
Operation Channel	: 11	Humidity	: 65 %
Modulation Type	: 802.11g	Atmospheric Pressure	: 1020 hPa
Memo	: MU18-2120150-A1	Rate	: 54Mbps

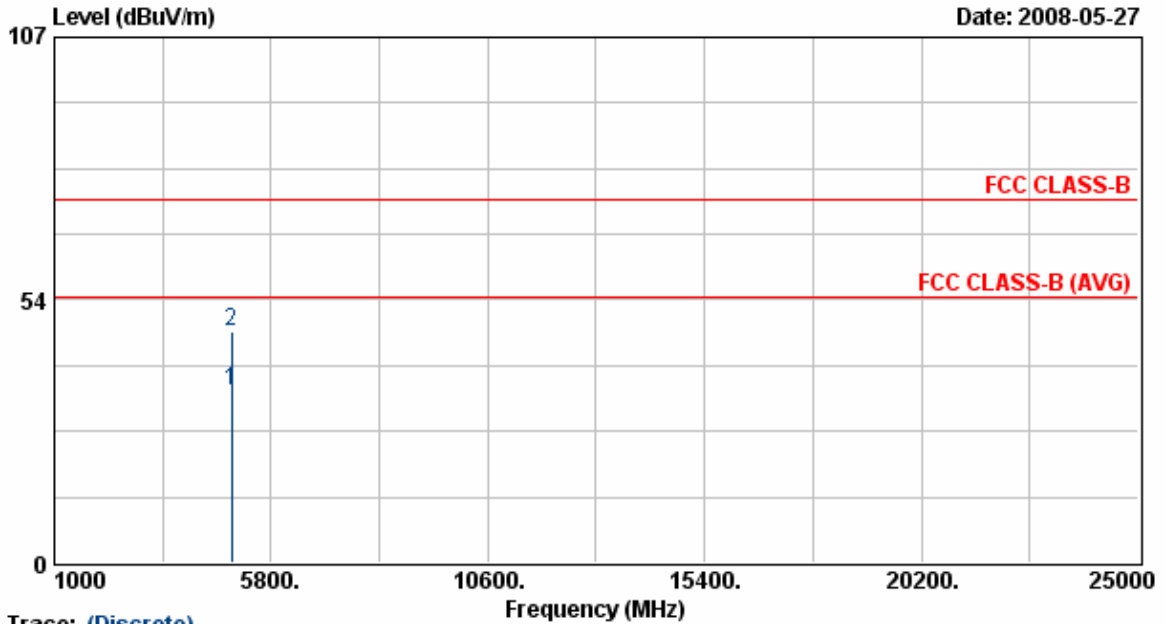

Trace: (Discrete)

Item	Freq	Read Value	Factor	Result	Limit	Margin	Remark	Ant Pos	Tab Pos
	MHz	dBuV/m	dB	dBuV/m	dBuV/m	dB		cm	Deg
1	4923.90	29.17	5.93	35.10	54.00	-18.90	Average	100	241
2	4923.90	41.04	5.93	46.97	74.00	-27.03	Peak	100	241

Notes:

1. Result = Read Value + Factor
2. Factor = Antenna Factor + Cable Loss - Amplifier
3. The resolution bandwidth of test receiver/spectrum analyzer is 120KHz and video bandwidth is 300kHz for Peak detection and Quasi-peak detection at frequency below 1GHz.
4. The resolution bandwidth of test receiver/spectrum analyzer is 1MHz and video bandwidth is 3MHz for Peak detection at frequency above 1GHz.
5. The resolution bandwidth of test receiver/spectrum analyzer is 1MHz and video bandwidth is 10Hz for Average detection at frequency above 1GHz.
6. The other emissions is too low to be measured.

Power	: AC 120V	Pol/Phase	: VERTICAL
Test Mode 2	: Transmit / Receive	Temperature	: 25 °C
Operation Channel	: 1	Humidity	: 65 %
Modulation Type	: 802.11n, HT20	Atmospheric Pressure	: 1020 hPa
Memo	: MU18-2120150-A1	Rate	: 130Mbps

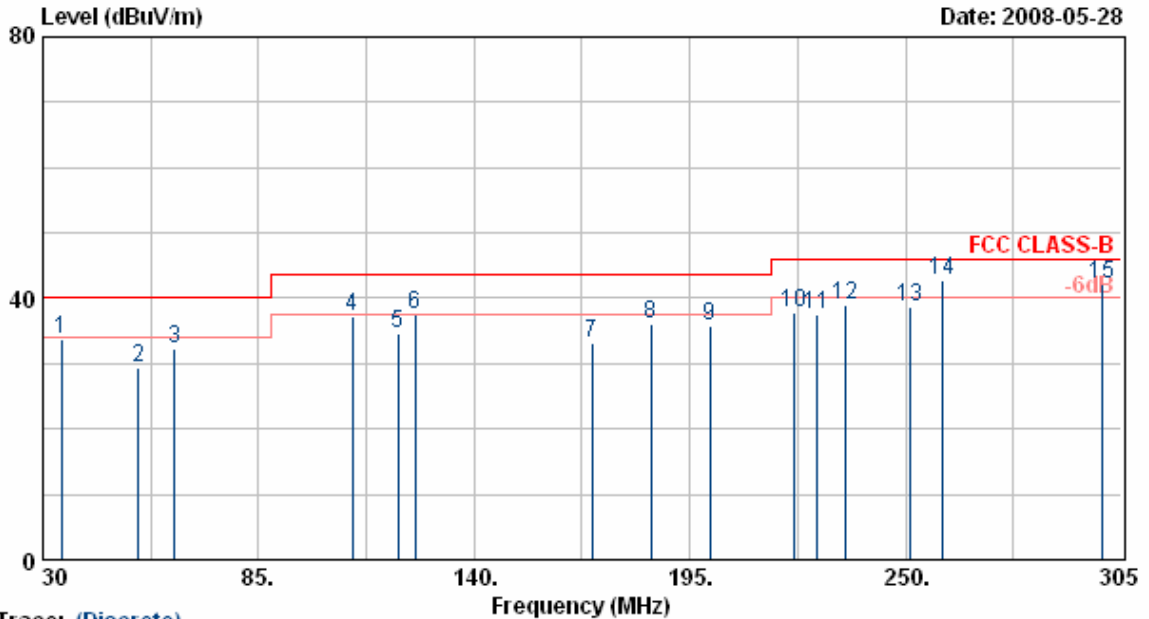

Trace: (Discrete)

Item	Freq	Read Value	Factor	Result	Limit	Margin	Remark	Ant Pos	Tab Pos
	MHz	dBuV/m	dB	dBuV/m	dBuV/m	dB		cm	Deg
1	34.68	41.80	-8.09	33.71	40.00	-6.29	Peak	100	98
2	54.48	45.22	-15.95	29.27	40.00	-10.73	Peak	100	155
3	63.55	50.86	-18.55	32.31	40.00	-7.69	Peak	100	155
4	108.85	50.70	-13.49	37.21	43.50	-6.29	Peak	100	162
5	120.48	48.30	-13.63	34.67	43.50	-8.83	Peak	100	182
6	125.03	50.90	-13.30	37.60	43.50	-5.90	QP	100	159
7	169.98	45.55	-12.38	33.17	43.50	-10.33	Peak	100	177
8	185.10	45.63	-9.56	36.07	43.50	-7.43	Peak	100	352
9	200.23	47.60	-11.71	35.89	43.50	-7.61	Peak	100	285
10	221.68	50.85	-13.10	37.75	46.00	-8.25	Peak	100	241
11	227.18	49.89	-12.42	37.47	46.00	-8.53	Peak	100	241
12	234.60	48.80	-9.75	39.05	46.00	-6.95	Peak	100	50
13	251.10	50.89	-12.33	38.56	46.00	-7.44	Peak	100	69
14	259.35	52.69	-9.97	42.72	46.00	-3.28	QP	100	88
15	300.04	51.60	-9.49	42.11	46.00	-3.89	QP	100	88

Notes:

1. Result = Read Value + Factor
2. Factor = Antenna Factor + Cable Loss - Amplifier
3. The resolution bandwidth of test receiver/spectrum analyzer is 120KHz and video bandwidth is 300kHz for Peak detection and Quasi-peak detection at frequency below 1GHz.
4. According to technical experiences, all spurious emission of 802.11MIMO mode at channel 1,6,11 are almost the same below 1GHz, so that the channel 1 was chosen as representative in final test.
5. The data is worse case.

Power	: AC 120V	Pol/Phase	: VERTICAL
Test Mode 2	: Transmit / Receive	Temperature	: 25 °C
Operation Channel	: 1	Humidity	: 65 %
Modulation Type	: 802.11n, HT20	Atmospheric Pressure	: 1020 hPa
Memo	: MU18-2120150-A1	Rate	: 130Mbps

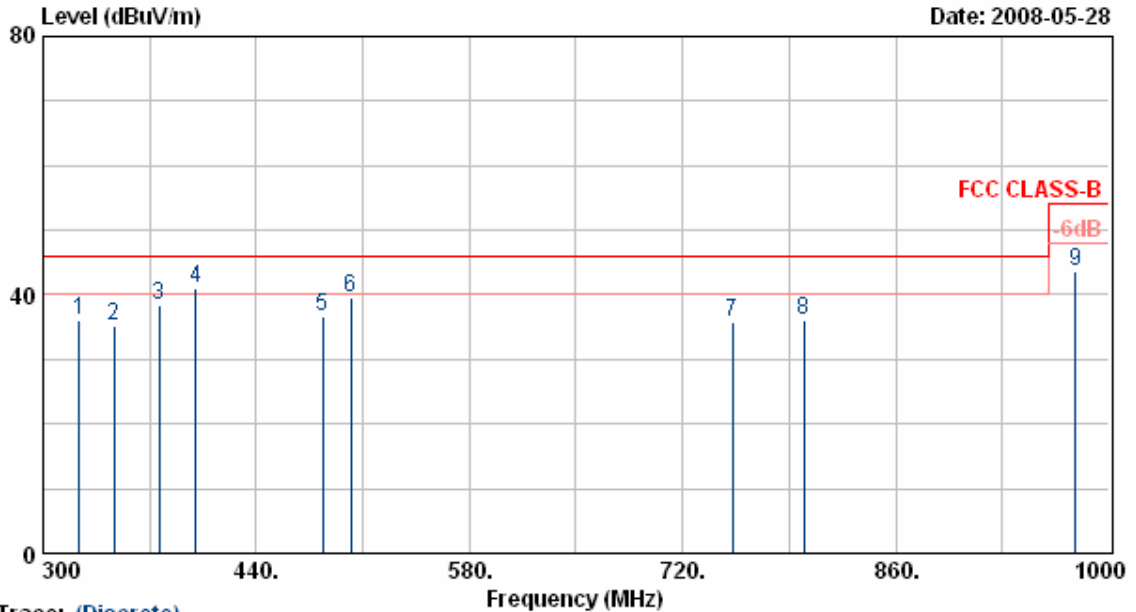

Trace: (Discrete)

Item	Freq MHz	Read Value dBuV/m	Factor dB	Result dBuV/m	Limit dBuV/m	Margin dB	Remark	Ant Pos cm	Tab Pos Deg
1	323.80	45.50	-9.42	36.08	46.00	-9.92	Peak	100	77
2	346.90	45.44	-10.31	35.13	46.00	-10.87	Peak	100	95
3	376.30	47.50	-9.17	38.33	46.00	-7.67	Peak	100	92
4	400.10	49.84	-8.80	41.04	46.00	-4.96	QP	100	185
5	483.40	41.48	-4.93	36.55	46.00	-9.45	Peak	100	222
6	502.30	44.53	-4.95	39.58	46.00	-6.42	Peak	100	241
7	752.90	35.53	0.38	35.91	46.00	-10.09	Peak	100	255
8	799.80	38.76	-2.83	35.93	46.00	-10.07	Peak	100	222
9	978.30	41.00	2.61	43.61	54.00	-10.39	Peak	100	222

Notes:

1. Result = Read Value + Factor
2. Factor = Antenna Factor + Cable Loss - Amplifier
3. The resolution bandwidth of test receiver/spectrum analyzer is 120KHz and video bandwidth is 300kHz for Peak detection and Quasi-peak detection at frequency below 1GHz.
4. According to technical experiences, all spurious emission of 802.11MIMO mode at channel 1,6,11 are almost the same below 1GHz, so that the channel 1 was chosen as representative in final test.
5. The data is worse case.

Power	: AC 120V	Pol/Phase	: HORIZONTAL
Test Mode 2	: Transmit / Receive	Temperature	: 25 °C
Operation Channel	: 1	Humidity	: 65 %
Modulation Type	: 802.11n, HT20	Atmospheric Pressure	: 1020 hPa
Memo	: MU18-2120150-A1	Rate	: 130Mbps

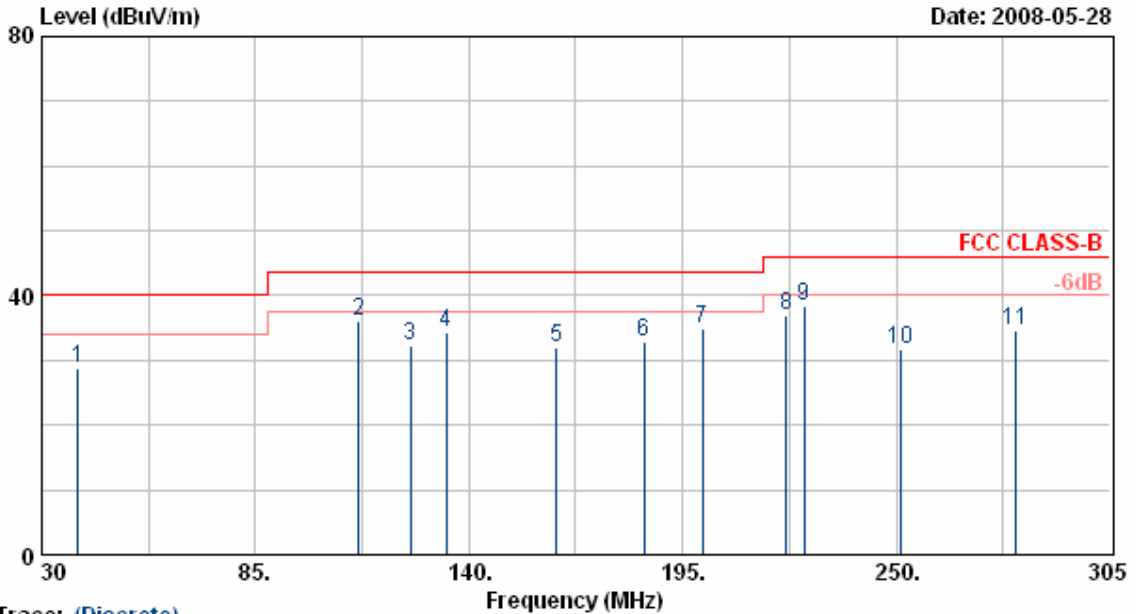

Trace: (Discrete)

Item	Freq MHz	Read Value dBuV/m	Factor dB	Result dBuV/m	Limit dBuV/m	Margin dB	Remark	Ant Pos cm	Tab Pos Deg
1	39.35	43.55	-14.87	28.68	40.00	-11.32	Peak	200	48
2	111.70	55.33	-19.23	36.10	43.50	-7.40	Peak	200	144
3	125.04	51.80	-19.54	32.26	43.50	-11.24	Peak	200	144
4	134.23	53.59	-19.35	34.24	43.50	-9.26	Peak	200	187
5	162.55	50.50	-18.50	32.00	43.50	-11.50	Peak	200	197
6	185.10	50.66	-17.81	32.85	43.50	-10.65	Peak	200	169
7	200.23	49.52	-14.58	34.94	43.50	-8.56	Peak	200	198
8	221.70	55.10	-18.06	37.04	46.00	-8.96	Peak	200	245
9	226.35	56.33	-18.07	38.26	46.00	-7.74	Peak	200	245
10	251.10	49.10	-17.31	31.79	46.00	-14.21	Peak	200	48
11	280.80	49.00	-14.28	34.72	46.00	-11.28	Peak	200	245

Notes:

1. Result = Read Value + Factor
2. Factor = Antenna Factor + Cable Loss - Amplifier
3. The resolution bandwidth of test receiver/spectrum analyzer is 120KHz and video bandwidth is 300kHz for Peak detection and Quasi-peak detection at frequency below 1GHz.
4. According to technical experiences, all spurious emission of 802.11MIMO mode at channel 1,6,11 are almost the same below 1GHz, so that the channel 1 was chosen as representative in final test.
5. The data is worse case.

Power	: AC 120V	Pol/Phase	: HORIZONTAL
Test Mode 2	: Transmit / Receive	Temperature	: 25 °C
Operation Channel	: 1	Humidity	: 65 %
Modulation Type	: 802.11n, HT20	Atmospheric Pressure	: 1020 hPa
Memo	: MU18-2120150-A1	Rate	: 130Mbps

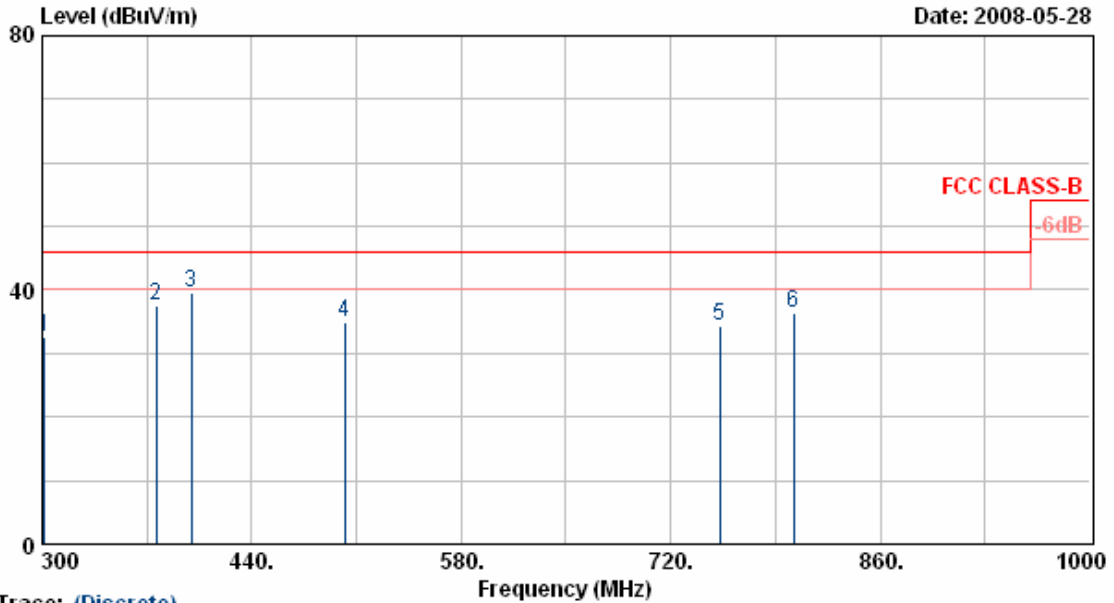

Trace: (Discrete)

Item	Freq	Read Value	Factor	Result	Limit	Margin	Remark	Ant Pos	Tab Pos
	MHz	dBuV/m	dB	dBuV/m	dBuV/m	dB		cm	Deg
1	301.40	46.95	-14.33	32.62	46.00	-13.38	Peak	200	47
2	376.30	48.50	-10.87	37.63	46.00	-8.37	Peak	200	54
3	399.40	50.65	-11.05	39.60	46.00	-6.40	Peak	200	54
4	502.30	39.95	-5.03	34.92	46.00	-11.08	Peak	200	88
5	752.90	34.22	-0.03	34.19	46.00	-11.81	Peak	200	155
6	801.90	36.66	-0.40	36.26	46.00	-9.74	Peak	200	111

Notes:

1. Result = Read Value + Factor
2. Factor = Antenna Factor + Cable Loss - Amplifier
3. The resolution bandwidth of test receiver/spectrum analyzer is 120KHz and video bandwidth is 300kHz for Peak detection and Quasi-peak detection at frequency below 1GHz.
4. According to technical experiences, all spurious emission of 802.11MIMO mode at channel 1,6,11 are almost the same below 1GHz, so that the channel 1 was chosen as representative in final test.
5. The data is worse case.

Power	: AC 120V	Pol/Phase	: VERTICAL
Test Mode 2	: Transmit / Receive	Temperature	: 25 °C
Operation Channel	: 1	Humidity	: 65 %
Modulation Type	: 802.11n, HT20	Atmospheric Pressure	: 1020 hPa
Memo	: MU18-2120150-A1	Rate	: 130Mbps

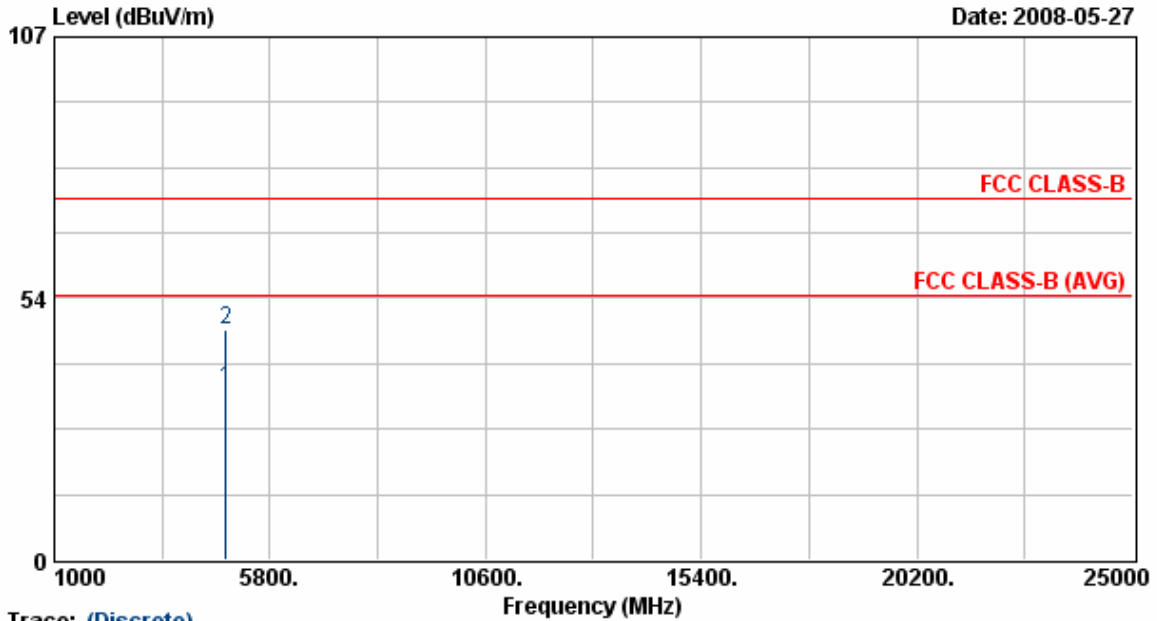

Trace: (Discrete)

Item	Freq	Read Value	Factor	Result	Limit	Margin	Remark	Ant Pos	Tab Pos
	MHz	dBuV/m	dB	dBuV/m	dBuV/m	dB		cm	Deg
1	4824.05	29.46	5.67	35.14	54.00	-18.86	Average	100	144
2	4824.05	41.25	5.67	46.93	74.00	-27.07	Peak	100	144

Notes:

1. Result = Read Value + Factor
2. Factor = Antenna Factor + Cable Loss - Amplifier
3. The resolution bandwidth of test receiver/spectrum analyzer is 120KHz and video bandwidth is 300kHz for Peak detection and Quasi-peak detection at frequency below 1GHz.
4. The resolution bandwidth of test receiver/spectrum analyzer is 1MHz and video bandwidth is 3MHz for Peak detection at frequency above 1GHz.
5. The resolution bandwidth of test receiver/spectrum analyzer is 1MHz and video bandwidth is 10Hz for Average detection at frequency above 1GHz.
6. The other emissions is too low to be measured.

Power	: AC 120V	Pol/Phase	: HORIZONTAL
Test Mode 2	: Transmit / Receive	Temperature	: 25 °C
Operation Channel	: 1	Humidity	: 65 %
Modulation Type	: 802.11n, HT20	Atmospheric Pressure	: 1020 hPa
Memo	: MU18-2120150-A1	Rate	: 130Mbps

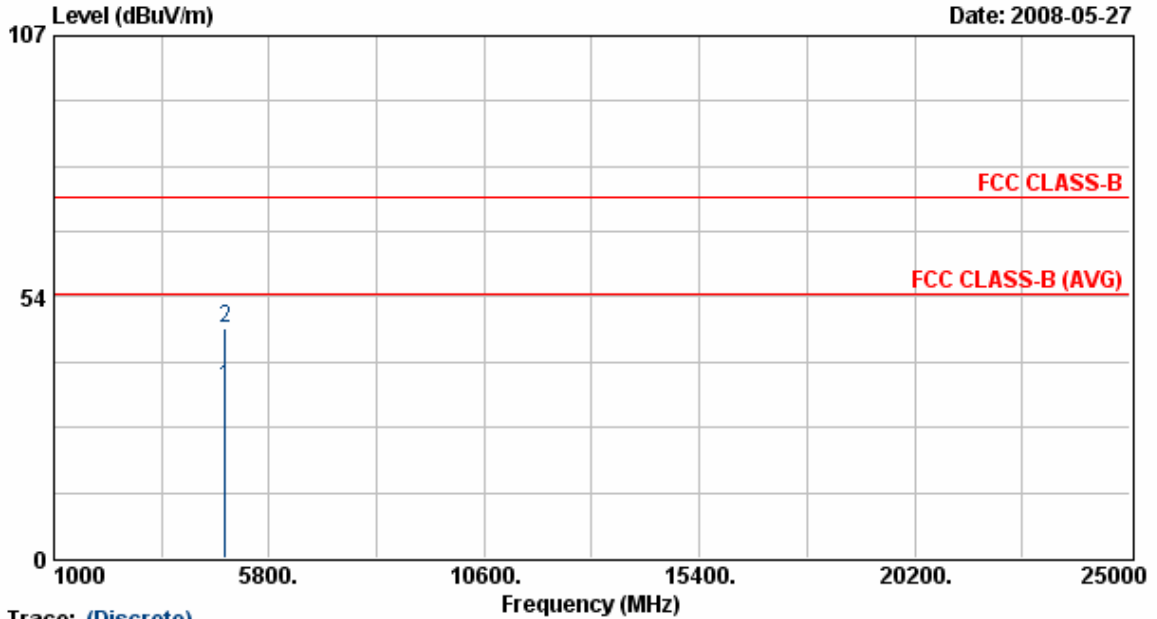

Trace: (Discrete)

Item	Freq	Read Value	Factor	Result	Limit	Margin	Remark	Ant Pos	Tab Pos
	MHz	dBuV/m	dB	dBuV/m	dBuV/m	dB		cm	Deg
1	4824.05	29.26	5.67	34.94	54.00	-19.06	Average	100	241
2	4824.05	41.24	5.67	46.91	74.00	-27.09	Peak	100	241

Notes:

1. Result = Read Value + Factor
2. Factor = Antenna Factor + Cable Loss - Amplifier
3. The resolution bandwidth of test receiver/spectrum analyzer is 120KHz and video bandwidth is 300kHz for Peak detection and Quasi-peak detection at frequency below 1GHz.
4. The resolution bandwidth of test receiver/spectrum analyzer is 1MHz and video bandwidth is 3MHz for Peak detection at frequency above 1GHz.
5. The resolution bandwidth of test receiver/spectrum analyzer is 1MHz and video bandwidth is 10Hz for Average detection at frequency above 1GHz.
6. The other emissions is too low to be measured.

Power	: AC 120V	Pol/Phase	: VERTICAL
Test Mode 2	: Transmit / Receive	Temperature	: 25 °C
Operation Channel	: 6	Humidity	: 65 %
Modulation Type	: 802.11n, HT20	Atmospheric Pressure	: 1020 hPa
Memo	: MU18-2120150-A1	Rate	: 130Mbps

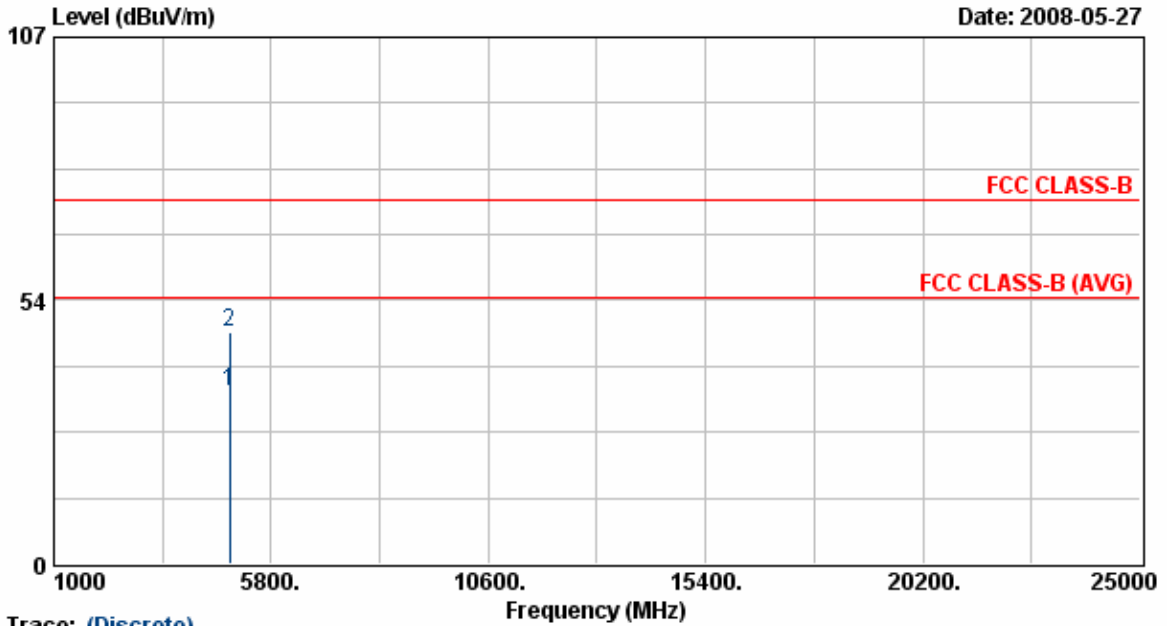

Trace: (Discrete)

Item	Freq	Read Value	Factor	Result	Limit	Margin	Remark	Ant Pos	Tab Pos
	MHz	dBuV/m	dB	dBuV/m	dBuV/m	dB		cm	Deg
1	4874.05	29.38	5.80	35.19	54.00	-18.81	Average	100	144
2	4874.05	41.31	5.80	47.11	74.00	-26.89	Peak	100	144

Notes:

1. Result = Read Value + Factor
2. Factor = Antenna Factor + Cable Loss - Amplifier
3. The resolution bandwidth of test receiver/spectrum analyzer is 120KHz and video bandwidth is 300kHz for Peak detection and Quasi-peak detection at frequency below 1GHz.
4. The resolution bandwidth of test receiver/spectrum analyzer is 1MHz and video bandwidth is 3MHz for Peak detection at frequency above 1GHz.
5. The resolution bandwidth of test receiver/spectrum analyzer is 1MHz and video bandwidth is 10Hz for Average detection at frequency above 1GHz.
6. The other emissions is too low to be measured.

Power	: AC 120V	Pol/Phase	: HORIZONTAL
Test Mode 2	: Transmit / Receive	Temperature	: 25 °C
Operation Channel	: 6	Humidity	: 65 %
Modulation Type	: 802.11n, HT20	Atmospheric Pressure	: 1020 hPa
Memo	: MU18-2120150-A1	Rate	: 130Mbps

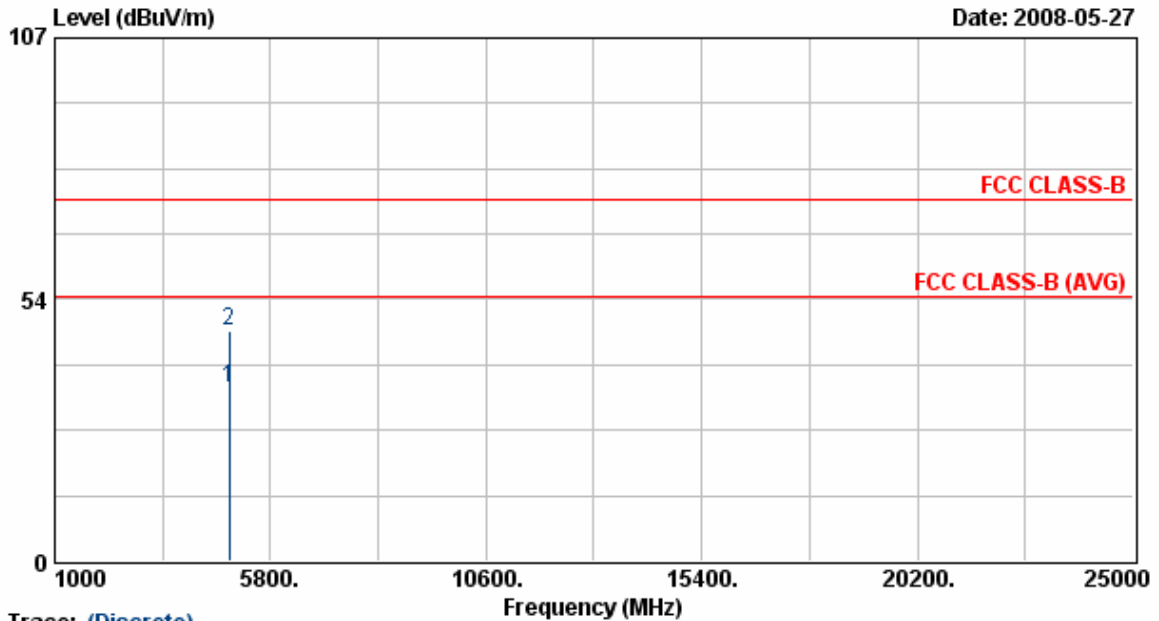

Trace: (Discrete)

Item	Freq	Read Value	Factor	Result	Limit	Margin	Remark	Ant Pos	Tab Pos
	MHz	dBuV/m	dB	dBuV/m	dBuV/m	dB		cm	Deg
1	4874.10	29.44	5.80	35.24	54.00	-18.76	Average	100	241
2	4874.10	41.24	5.80	47.04	74.00	-26.96	Peak	100	241

Notes:

1. Result = Read Value + Factor
2. Factor = Antenna Factor + Cable Loss - Amplifier
3. The resolution bandwidth of test receiver/spectrum analyzer is 120KHz and video bandwidth is 300kHz for Peak detection and Quasi-peak detection at frequency below 1GHz.
4. The resolution bandwidth of test receiver/spectrum analyzer is 1MHz and video bandwidth is 3MHz for Peak detection at frequency above 1GHz.
5. The resolution bandwidth of test receiver/spectrum analyzer is 1MHz and video bandwidth is 10Hz for Average detection at frequency above 1GHz.
6. The other emissions is too low to be measured.

Power	: AC 120V	Pol/Phase	: VERTICAL
Test Mode 2	: Transmit / Receive	Temperature	: 25 °C
Operation Channel	: 11	Humidity	: 65 %
Modulation Type	: 802.11n, HT20	Atmospheric Pressure	: 1020 hPa
Memo	: MU18-2120150-A1	Rate	: 130Mbps

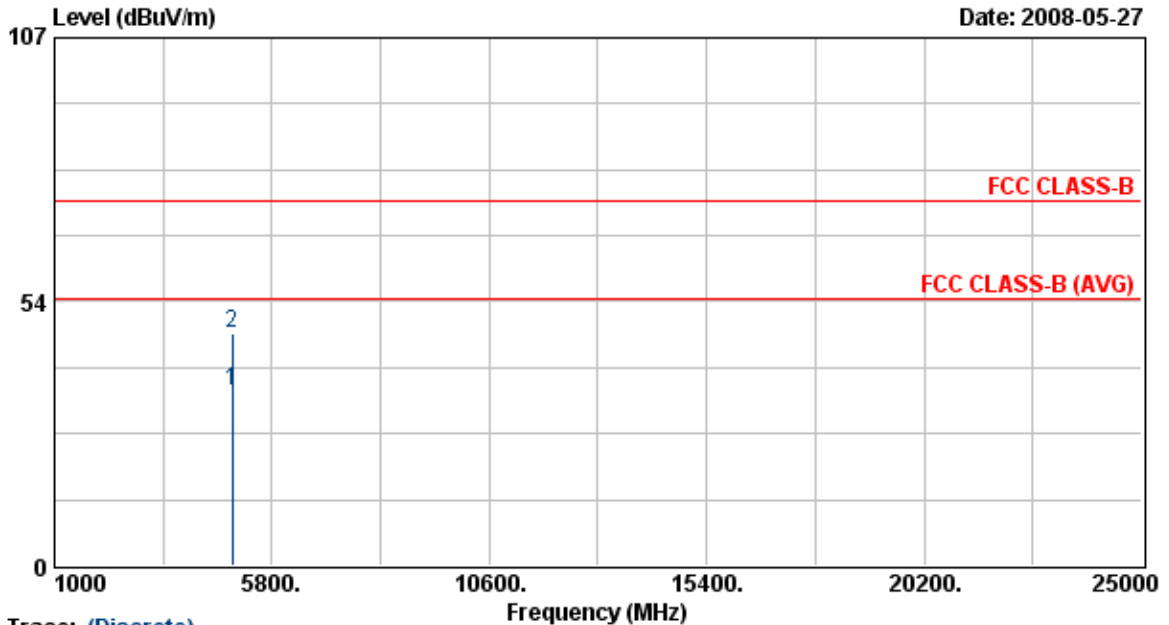

Trace: (Discrete)

Item	Freq	Read Value	Factor	Result	Limit	Margin	Remark	Ant Pos	Tab Pos
	MHz	dBuV/m	dB	dBuV/m	dBuV/m	dB		cm	Deg
1	4923.90	29.54	5.93	35.47	54.00	-18.53	Average	100	144
2	4923.90	41.11	5.93	47.05	74.00	-26.95	Peak	100	144

Notes:

1. Result = Read Value + Factor
2. Factor = Antenna Factor + Cable Loss - Amplifier
3. The resolution bandwidth of test receiver/spectrum analyzer is 120KHz and video bandwidth is 300kHz for Peak detection and Quasi-peak detection at frequency below 1GHz.
4. The resolution bandwidth of test receiver/spectrum analyzer is 1MHz and video bandwidth is 3MHz for Peak detection at frequency above 1GHz.
5. The resolution bandwidth of test receiver/spectrum analyzer is 1MHz and video bandwidth is 10Hz for Average detection at frequency above 1GHz.
6. The other emissions is too low to be measured.

Power	: AC 120V	Pol/Phase	: HORIZONTAL
Test Mode 2	: Transmit / Receive	Temperature	: 25 °C
Operation Channel	: 11	Humidity	: 65 %
Modulation Type	: 802.11n, HT20	Atmospheric Pressure	: 1020 hPa
Memo	: MU18-2120150-A1	Rate	: 130Mbps

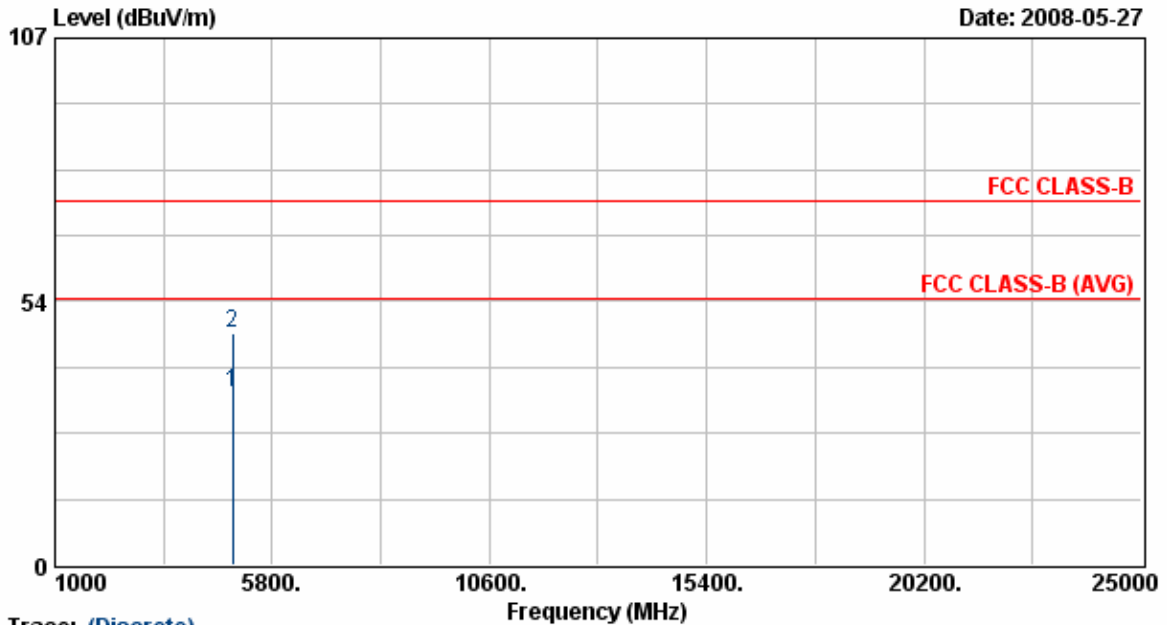

Trace: (Discrete)

Item	Freq	Read Value	Factor	Result	Limit	Margin	Remark	Ant Pos	Tab Pos
	MHz	dBuV/m	dB	dBuV/m	dBuV/m	dB		cm	Deg
1	4924.05	29.22	5.93	35.16	54.00	-18.84	Average	100	241
2	4924.05	41.04	5.93	46.98	74.00	-27.02	Peak	100	241

Notes:

1. Result = Read Value + Factor
2. Factor = Antenna Factor + Cable Loss - Amplifier
3. The resolution bandwidth of test receiver/spectrum analyzer is 120KHz and video bandwidth is 300kHz for Peak detection and Quasi-peak detection at frequency below 1GHz.
4. The resolution bandwidth of test receiver/spectrum analyzer is 1MHz and video bandwidth is 3MHz for Peak detection at frequency above 1GHz.
5. The resolution bandwidth of test receiver/spectrum analyzer is 1MHz and video bandwidth is 10Hz for Average detection at frequency above 1GHz.
6. The other emissions is too low to be measured.

Power	: AC 120V	Pol/Phase	: VERTICAL
Test Mode 2	: Transmit / Receive	Temperature	: 25 °C
Operation Channel	: 3	Humidity	: 65 %
Modulation Type	: 802.11n, HT40	Atmospheric Pressure	: 1020 hPa
Memo	: MU18-2120150-A1	Rate	: 270Mbps

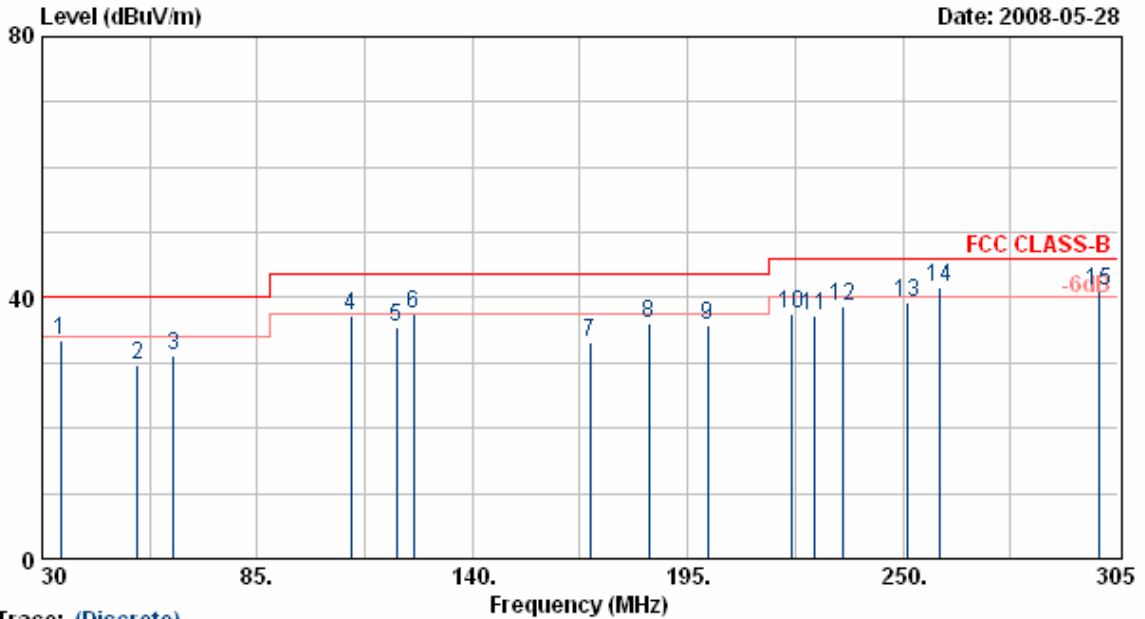

Trace: (Discrete)

Item	Freq	Read Value	Factor	Result	Limit	Margin	Remark	Ant Pos	Tab Pos
	MHz	dBuV/m	dB	dBuV/m	dBuV/m	dB		cm	Deg
1	34.68	41.66	-8.09	33.57	40.00	-6.43	Peak	100	98
2	54.48	45.70	-15.95	29.75	40.00	-10.25	Peak	100	155
3	63.55	49.80	-18.55	31.25	40.00	-8.75	Peak	100	155
4	108.85	50.70	-13.49	37.21	43.50	-6.29	Peak	100	162
5	120.48	48.99	-13.63	35.36	43.50	-8.14	Peak	100	182
6	125.03	50.92	-13.30	37.62	43.50	-5.88	QP	100	159
7	169.98	45.42	-12.38	33.04	43.50	-10.46	Peak	100	177
8	185.10	45.50	-9.56	35.94	43.50	-7.56	Peak	100	352
9	200.23	47.45	-11.71	35.74	43.50	-7.76	Peak	100	285
10	221.68	50.66	-13.10	37.56	46.00	-8.44	Peak	100	241
11	227.18	49.76	-12.42	37.34	46.00	-8.66	Peak	100	241
12	234.60	48.55	-9.75	38.80	46.00	-7.20	Peak	100	50
13	251.10	51.66	-12.33	39.33	46.00	-6.67	Peak	100	69
14	259.35	51.62	-9.97	41.65	46.00	-4.35	QP	100	88
15	300.04	50.50	-9.49	41.01	46.00	-4.99	QP	100	88

Notes:

1. Result = Read Value + Factor
2. Factor = Antenna Factor + Cable Loss - Amplifier
3. The resolution bandwidth of test receiver/spectrum analyzer is 120KHz and video bandwidth is 300kHz for Peak detection and Quasi-peak detection at frequency below 1GHz.
4. According to technical experiences, all spurious emission of 802.11MIMO mode at channel 3,6,9 are almost the same below 1GHz, so that the channel 3 was chosen as representative in final test.
5. The data is worse case.

Power	: AC 120V	Pol/Phase	: VERTICAL
Test Mode 2	: Transmit / Receive	Temperature	: 25 °C
Operation Channel	: 3	Humidity	: 65 %
Modulation Type	: 802.11n, HT40	Atmospheric Pressure	: 1020 hPa
Memo	: MU18-2120150-A1	Rate	: 270Mbps

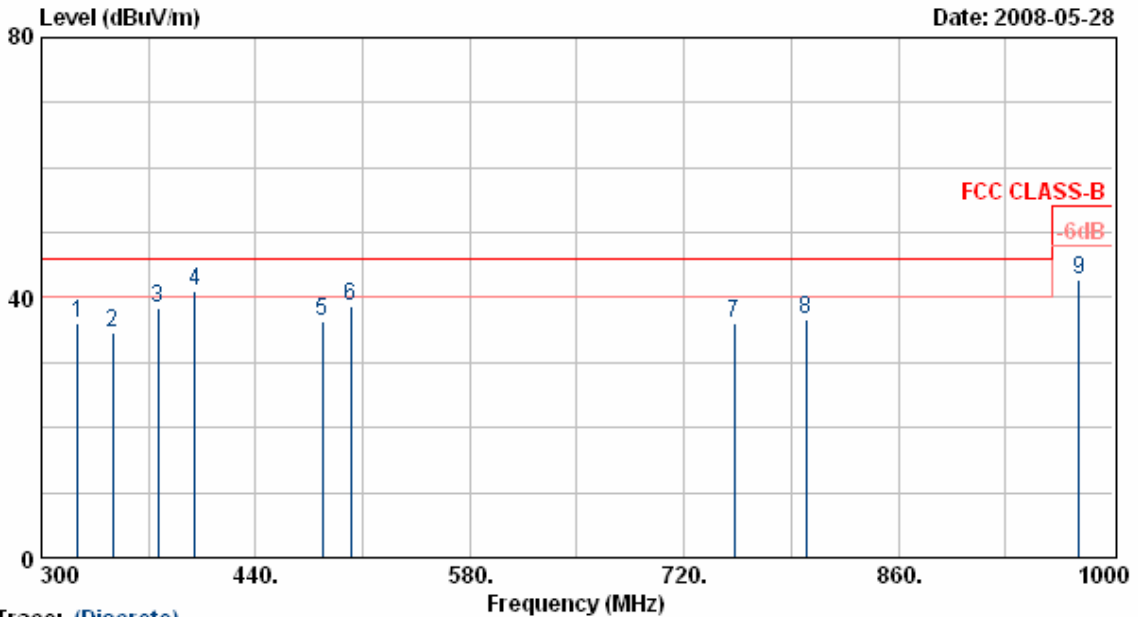

Trace: (Discrete)

Item	Freq	Read Value	Factor	Result	Limit	Margin	Remark	Ant Pos	Tab Pos
	MHz	dBuV/m	dB	dBuV/m	dBuV/m	dB		cm	Deg
1	323.80	45.62	-9.42	36.20	46.00	-9.80	Peak	100	77
2	346.90	44.93	-10.31	34.62	46.00	-11.38	Peak	100	95
3	376.30	47.46	-9.17	38.29	46.00	-7.71	Peak	100	92
4	400.10	49.84	-8.80	41.04	46.00	-4.96	QP	100	185
5	483.40	41.22	-4.93	36.29	46.00	-9.71	Peak	100	222
6	502.30	43.58	-4.95	38.63	46.00	-7.37	Peak	100	241
7	752.90	35.59	0.38	35.97	46.00	-10.03	Peak	100	255
8	799.80	39.36	-2.83	36.53	46.00	-9.47	Peak	100	222
9	978.30	40.10	2.61	42.71	54.00	-11.29	Peak	100	222

Notes:

1. Result = Read Value + Factor
2. Factor = Antenna Factor + Cable Loss - Amplifier
3. The resolution bandwidth of test receiver/spectrum analyzer is 120KHz and video bandwidth is 300kHz for Peak detection and Quasi-peak detection at frequency below 1GHz.
4. According to technical experiences, all spurious emission of 802.11MIMO mode at channel 3,6,9 are almost the same below 1GHz, so that the channel 3 was chosen as representative in final test.
5. The data is worse case.

Power	: AC 120V	Pol/Phase	: HORIZONTAL
Test Mode 2	: Transmit / Receive	Temperature	: 25 °C
Operation Channel	: 3	Humidity	: 65 %
Modulation Type	: 802.11n, HT40	Atmospheric Pressure	: 1020 hPa
Memo	: MU18-2120150-A1	Rate	: 270Mbps

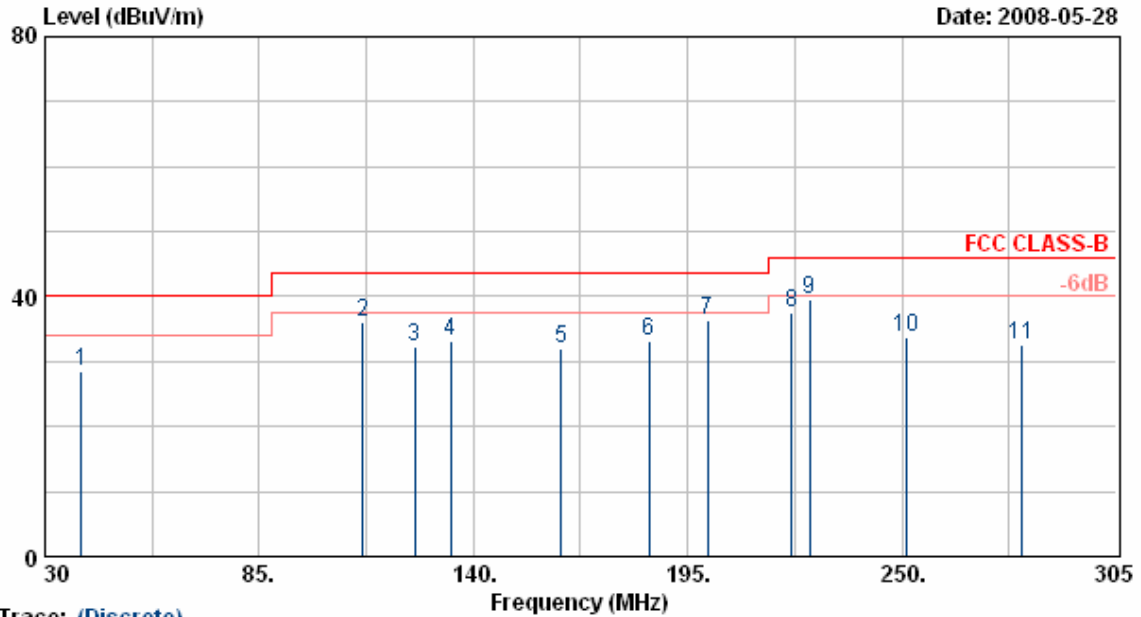

Trace: (Discrete)

Item	Freq MHz	Read Value dBuV/m	Factor dB	Result dBuV/m	Limit dBuV/m	Margin dB	Remark	Ant Pos cm	Tab Pos Deg
1	39.35	43.42	-14.87	28.55	40.00	-11.45	Peak	200	48
2	111.70	55.36	-19.23	36.13	43.50	-7.37	Peak	200	144
3	125.04	51.69	-19.54	32.15	43.50	-11.35	Peak	200	144
4	134.23	52.44	-19.35	33.09	43.50	-10.41	Peak	200	187
5	162.55	50.50	-18.50	32.00	43.50	-11.50	Peak	200	197
6	185.10	50.91	-17.81	33.10	43.50	-10.40	Peak	200	169
7	200.23	50.97	-14.58	36.39	43.50	-7.11	Peak	200	198
8	221.70	55.69	-18.06	37.63	46.00	-8.37	Peak	200	245
9	226.35	57.50	-18.07	39.43	46.00	-6.57	Peak	200	245
10	251.10	51.10	-17.31	33.79	46.00	-12.21	Peak	200	48
11	280.80	47.00	-14.28	32.72	46.00	-13.28	Peak	200	245

Notes:

1. Result = Read Value + Factor
2. Factor = Antenna Factor + Cable Loss - Amplifier
3. The resolution bandwidth of test receiver/spectrum analyzer is 120KHz and video bandwidth is 300kHz for Peak detection and Quasi-peak detection at frequency below 1GHz.
4. According to technical experiences, all spurious emission of 802.11MIMO mode at channel 3,6,9 are almost the same below 1GHz, so that the channel 3 was chosen as representative in final test.
5. The data is worse case.

Power	: AC 120V	Pol/Phase	: HORIZONTAL
Test Mode 2	: Transmit / Receive	Temperature	: 25 °C
Operation Channel	: 3	Humidity	: 65 %
Modulation Type	: 802.11n, HT40	Atmospheric Pressure	: 1020 hPa
Memo	: MU18-2120150-A1	Rate	: 270Mbps

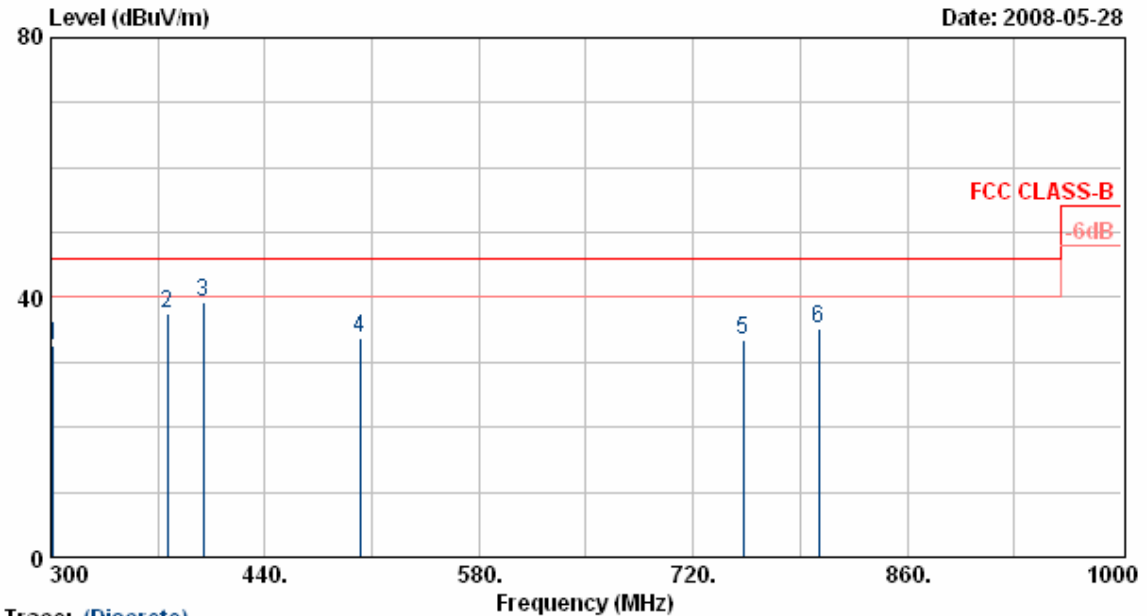

Trace: (Discrete)

Item	Freq	Read Value	Factor	Result	Limit	Margin	Remark	Ant Pos	Tab Pos
	MHz	dBuV/m	dB	dBuV/m	dBuV/m	dB		cm	Deg
1	301.40	46.98	-14.33	32.65	46.00	-13.35	Peak	200	47
2	376.30	48.26	-10.87	37.39	46.00	-8.61	Peak	200	54
3	399.40	50.33	-11.05	39.28	46.00	-6.72	Peak	200	54
4	502.30	38.90	-5.03	33.87	46.00	-12.13	Peak	200	88
5	752.90	33.55	-0.03	33.52	46.00	-12.48	Peak	200	155
6	801.90	35.60	-0.40	35.20	46.00	-10.80	Peak	200	111

Notes:

1. Result = Read Value + Factor
2. Factor = Antenna Factor + Cable Loss - Amplifier
3. The resolution bandwidth of test receiver/spectrum analyzer is 120KHz and video bandwidth is 300kHz for Peak detection and Quasi-peak detection at frequency below 1GHz.
4. According to technical experiences, all spurious emission of 802.11MIMO mode at channel 3,6,9 are almost the same below 1GHz, so that the channel 3 was chosen as representative in final test.
5. The data is worse case.

Power	: AC 120V	Pol/Phase	: VERTICAL
Test Mode 2	: Transmit / Receive	Temperature	: 25 °C
Operation Channel	: 3	Humidity	: 65 %
Modulation Type	: 802.11n, HT40	Atmospheric Pressure	: 1020 hPa
Memo	: MU18-2120150-A1	Rate	: 270Mbps

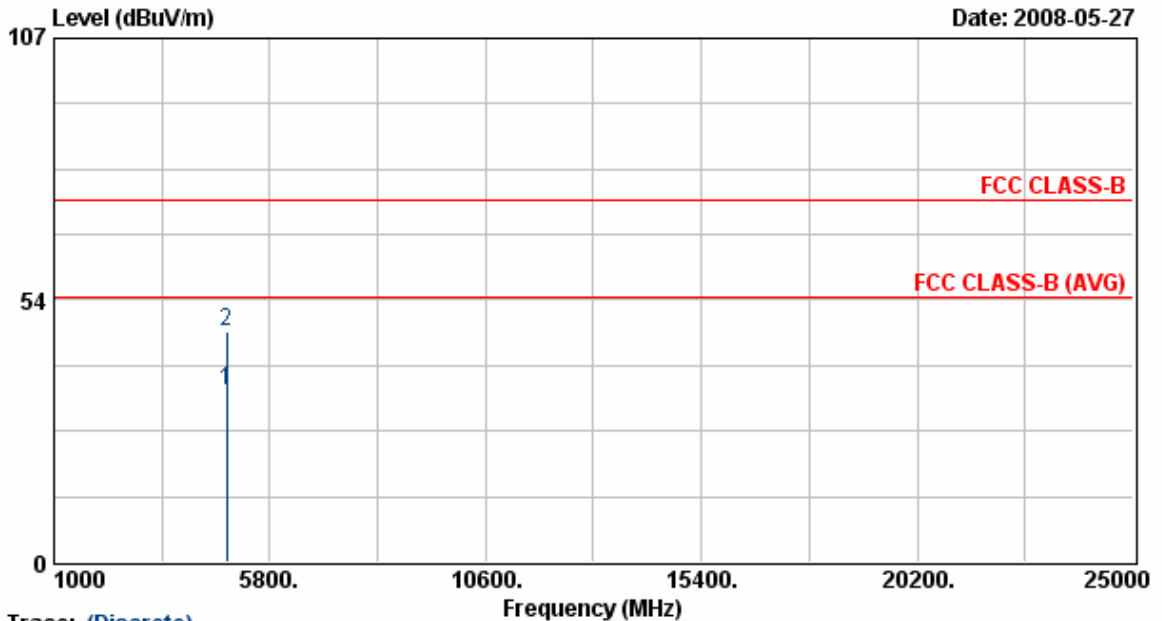

Trace: (Discrete)

Item	Freq	Read Value	Factor	Result	Limit	Margin	Remark	Ant Pos	Tab Pos
	MHz	dBuV/m	dB	dBuV/m	dBuV/m	dB		cm	Deg
1	4844.23	29.47	5.72	35.19	54.00	-18.81	Average	100	144
2	4844.23	41.17	5.72	46.89	74.00	-27.11	Peak	100	144

Notes:

1. Result = Read Value + Factor
2. Factor = Antenna Factor + Cable Loss - Amplifier
3. The resolution bandwidth of test receiver/spectrum analyzer is 120KHz and video bandwidth is 300kHz for Peak detection and Quasi-peak detection at frequency below 1GHz.
4. The resolution bandwidth of test receiver/spectrum analyzer is 1MHz and video bandwidth is 3MHz for Peak detection at frequency above 1GHz.
5. The resolution bandwidth of test receiver/spectrum analyzer is 1MHz and video bandwidth is 10Hz for Average detection at frequency above 1GHz.
6. The other emissions is too low to be measured.

Power	: AC 120V	Pol/Phase	: HORIZONTAL
Test Mode 2	: Transmit / Receive	Temperature	: 25 °C
Operation Channel	: 3	Humidity	: 65 %
Modulation Type	: 802.11n, HT40	Atmospheric Pressure	: 1020 hPa
Memo	: MU18-2120150-A1	Rate	: 270Mbps

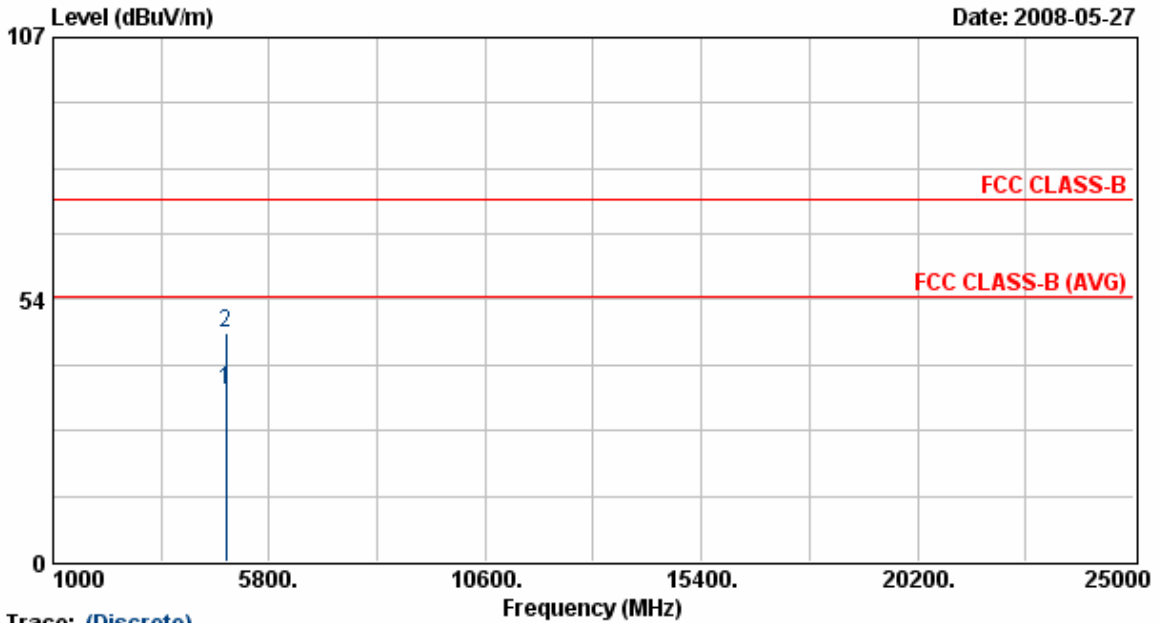

Trace: (Discrete)

Item	Freq	Read Value	Factor	Result	Limit	Margin	Remark	Ant Pos	Tab Pos
	MHz	dBuV/m	dB	dBuV/m	dBuV/m	dB		cm	Deg
1	4843.83	29.34	5.72	35.06	54.00	-18.94	Average	100	241
2	4843.83	41.16	5.72	46.88	74.00	-27.12	Peak	100	241

Notes:

1. Result = Read Value + Factor
2. Factor = Antenna Factor + Cable Loss - Amplifier
3. The resolution bandwidth of test receiver/spectrum analyzer is 120KHz and video bandwidth is 300kHz for Peak detection and Quasi-peak detection at frequency below 1GHz.
4. The resolution bandwidth of test receiver/spectrum analyzer is 1MHz and video bandwidth is 3MHz for Peak detection at frequency above 1GHz.
5. The resolution bandwidth of test receiver/spectrum analyzer is 1MHz and video bandwidth is 10Hz for Average detection at frequency above 1GHz.
6. The other emissions is too low to be measured.

Power	: AC 120V	Pol/Phase	: VERTICAL
Test Mode 2	: Transmit / Receive	Temperature	: 25 °C
Operation Channel	: 6	Humidity	: 65 %
Modulation Type	: 802.11n, HT40	Atmospheric Pressure	: 1020 hPa
Memo	: MU18-2120150-A1	Rate	: 270Mbps

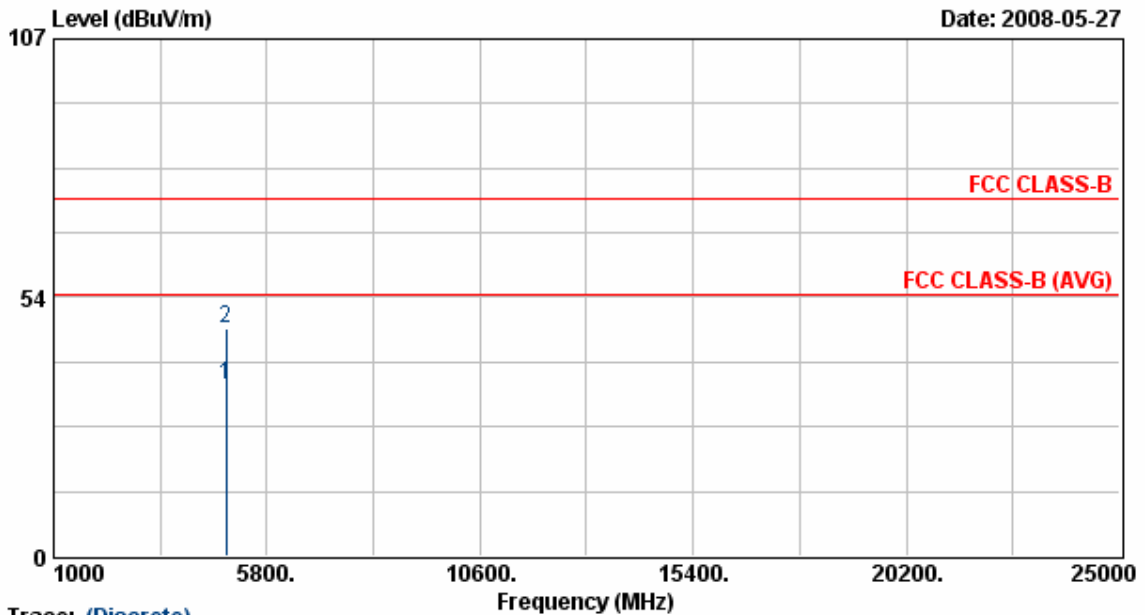

Trace: (Discrete)

Item	Freq	Read Value	Factor	Result	Limit	Margin	Remark	Ant Pos	Tab Pos
	MHz	dBuV/m	dB	dBuV/m	dBuV/m	dB		cm	Deg
1	4874.03	29.67	5.80	35.47	54.00	-18.53	Average	100	144
2	4874.03	41.13	5.80	46.93	74.00	-27.07	Peak	100	144

Notes:

1. Result = Read Value + Factor
2. Factor = Antenna Factor + Cable Loss - Amplifier
3. The resolution bandwidth of test receiver/spectrum analyzer is 120KHz and video bandwidth is 300kHz for Peak detection and Quasi-peak detection at frequency below 1GHz.
4. The resolution bandwidth of test receiver/spectrum analyzer is 1MHz and video bandwidth is 3MHz for Peak detection at frequency above 1GHz.
5. The resolution bandwidth of test receiver/spectrum analyzer is 1MHz and video bandwidth is 10Hz for Average detection at frequency above 1GHz.
6. The other emissions is too low to be measured.

Power	: AC 120V	Pol/Phase	: HORIZONTAL
Test Mode 2	: Transmit / Receive	Temperature	: 25 °C
Operation Channel	: 6	Humidity	: 65 %
Modulation Type	: 802.11n, HT40	Atmospheric Pressure	: 1020 hPa
Memo	: MU18-2120150-A1	Rate	: 270Mbps

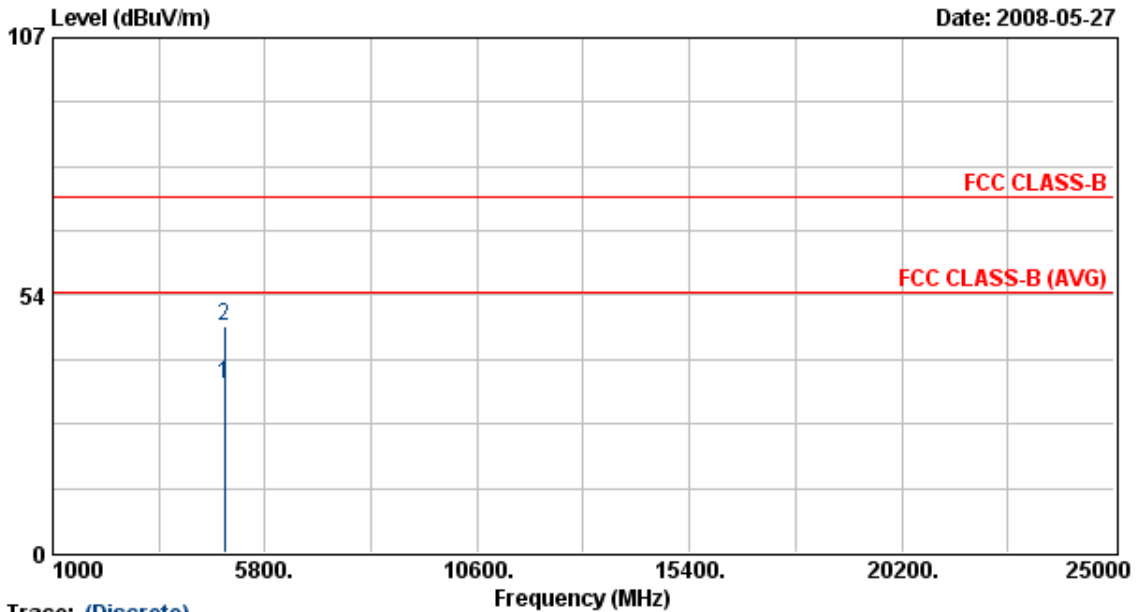

Trace: (Discrete)

Item	Freq	Read Value	Factor	Result	Limit	Margin	Remark	Ant Pos	Tab Pos
	MHz	dBuV/m	dB	dBuV/m	dBuV/m	dB		cm	Deg
1	4874.08	29.40	5.80	35.20	54.00	-18.80	Average	100	241
2	4874.08	41.19	5.80	46.99	74.00	-27.01	Peak	100	241

Notes:

1. Result = Read Value + Factor
2. Factor = Antenna Factor + Cable Loss - Amplifier
3. The resolution bandwidth of test receiver/spectrum analyzer is 120KHz and video bandwidth is 300kHz for Peak detection and Quasi-peak detection at frequency below 1GHz.
4. The resolution bandwidth of test receiver/spectrum analyzer is 1MHz and video bandwidth is 3MHz for Peak detection at frequency above 1GHz.
5. The resolution bandwidth of test receiver/spectrum analyzer is 1MHz and video bandwidth is 10Hz for Average detection at frequency above 1GHz.
6. The other emissions is too low to be measured.

Power	: AC 120V	Pol/Phase	: VERTICAL
Test Mode 2	: Transmit / Receive	Temperature	: 25 °C
Operation Channel	: 9	Humidity	: 65 %
Modulation Type	: 802.11n, HT40	Atmospheric Pressure	: 1020 hPa
Memo	: MU18-2120150-A1	Rate	: 270Mbps

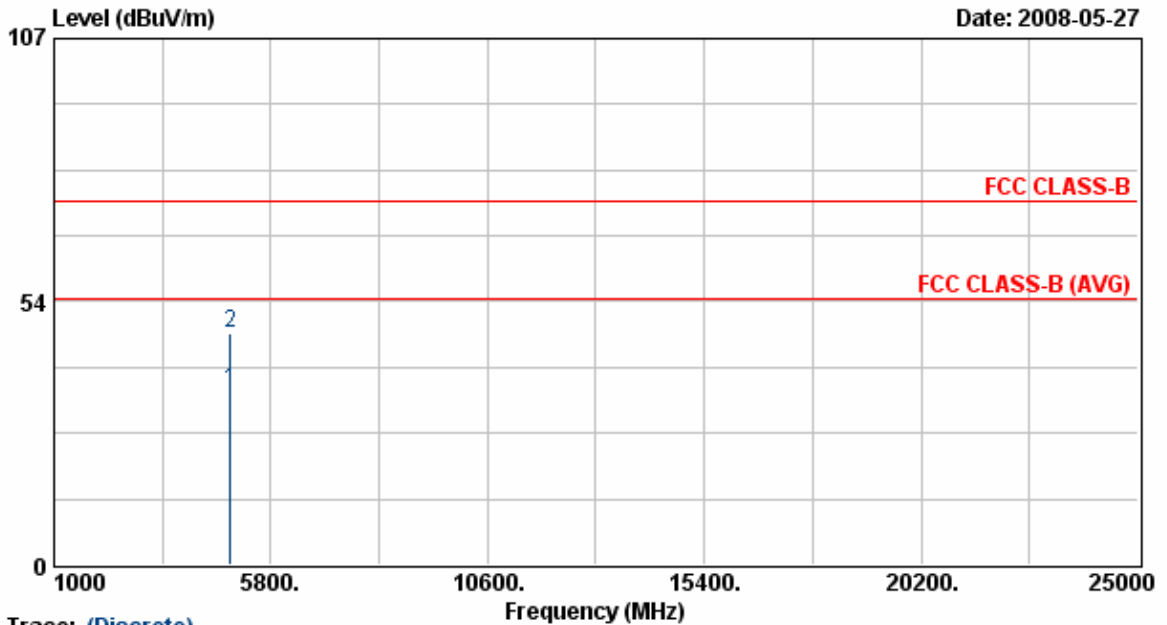

Trace: (Discrete)

Item	Freq	Read Value	Factor	Result	Limit	Margin	Remark	Ant Pos	Tab Pos
	MHz	dBuV/m	dB	dBuV/m	dBuV/m	dB		cm	Deg
1	4903.90	29.45	5.88	35.33	54.00	-18.67	Average	100	144
2	4903.90	41.28	5.88	47.16	74.00	-26.84	Peak	100	144

Notes:

1. Result = Read Value + Factor
2. Factor = Antenna Factor + Cable Loss - Amplifier
3. The resolution bandwidth of test receiver/spectrum analyzer is 120KHz and video bandwidth is 300kHz for Peak detection and Quasi-peak detection at frequency below 1GHz.
4. The resolution bandwidth of test receiver/spectrum analyzer is 1MHz and video bandwidth is 3MHz for Peak detection at frequency above 1GHz.
5. The resolution bandwidth of test receiver/spectrum analyzer is 1MHz and video bandwidth is 10Hz for Average detection at frequency above 1GHz.
6. The other emissions is too low to be measured.

Power	: AC 120V	Pol/Phase	: HORIZONTAL
Test Mode 2	: Transmit / Receive	Temperature	: 25 °C
Operation Channel	: 9	Humidity	: 65 %
Modulation Type	: 802.11n, HT40	Atmospheric Pressure	: 1020 hPa
Memo	: MU18-2120150-A1	Rate	: 270Mbps

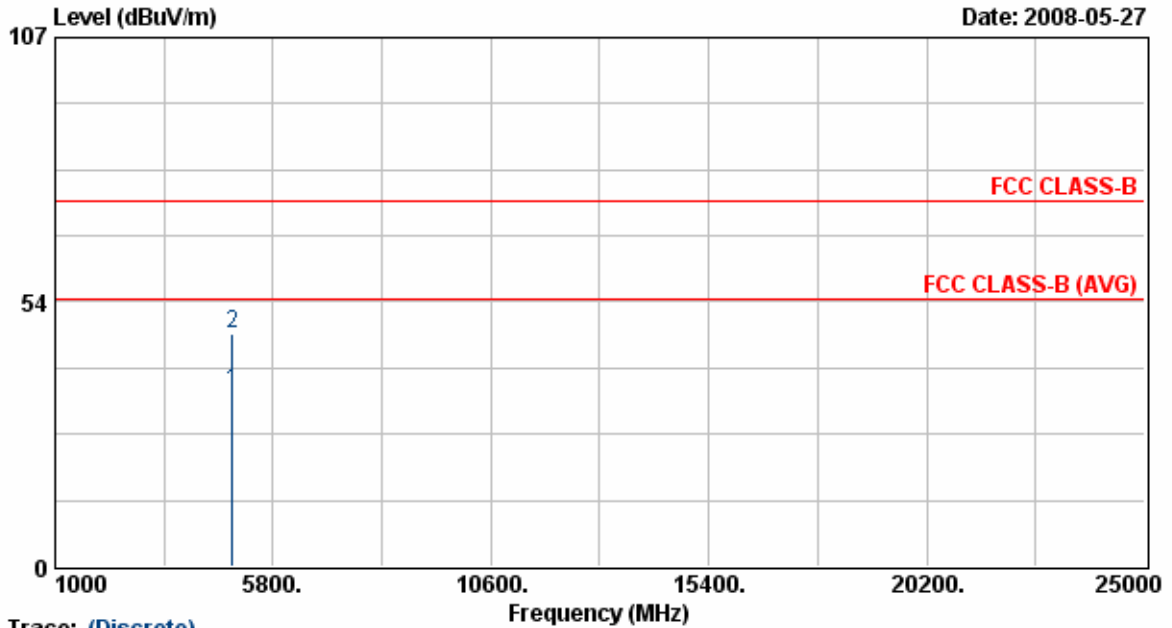

Trace: (Discrete)

Item	Freq	Read Value	Factor	Result	Limit	Margin	Remark	Ant Pos	Tab Pos
	MHz	dBuV/m	dB	dBuV/m	dBuV/m	dB		cm	Deg
1	4904.15	29.47	5.88	35.35	54.00	-18.65	Average	100	241
2	4904.15	41.23	5.88	47.11	74.00	-26.89	Peak	100	241

Notes:

1. Result = Read Value + Factor
2. Factor = Antenna Factor + Cable Loss - Amplifier
3. The resolution bandwidth of test receiver/spectrum analyzer is 120KHz and video bandwidth is 300kHz for Peak detection and Quasi-peak detection at frequency below 1GHz.
4. The resolution bandwidth of test receiver/spectrum analyzer is 1MHz and video bandwidth is 3MHz for Peak detection at frequency above 1GHz.
5. The resolution bandwidth of test receiver/spectrum analyzer is 1MHz and video bandwidth is 10Hz for Average detection at frequency above 1GHz.
6. The other emissions is too low to be measured.

Power	: AC 120V	Pol/Phase	: VERTICAL
Test Mode 3	: Transmit / Receive	Temperature	: 25 °C
Operation Channel	: 1	Humidity	: 65 %
Modulation Type	: 802.11g	Atmospheric Pressure	: 1020 hPa
Memo	: MT12-Y120100-A1	Rate	: 54Mbps

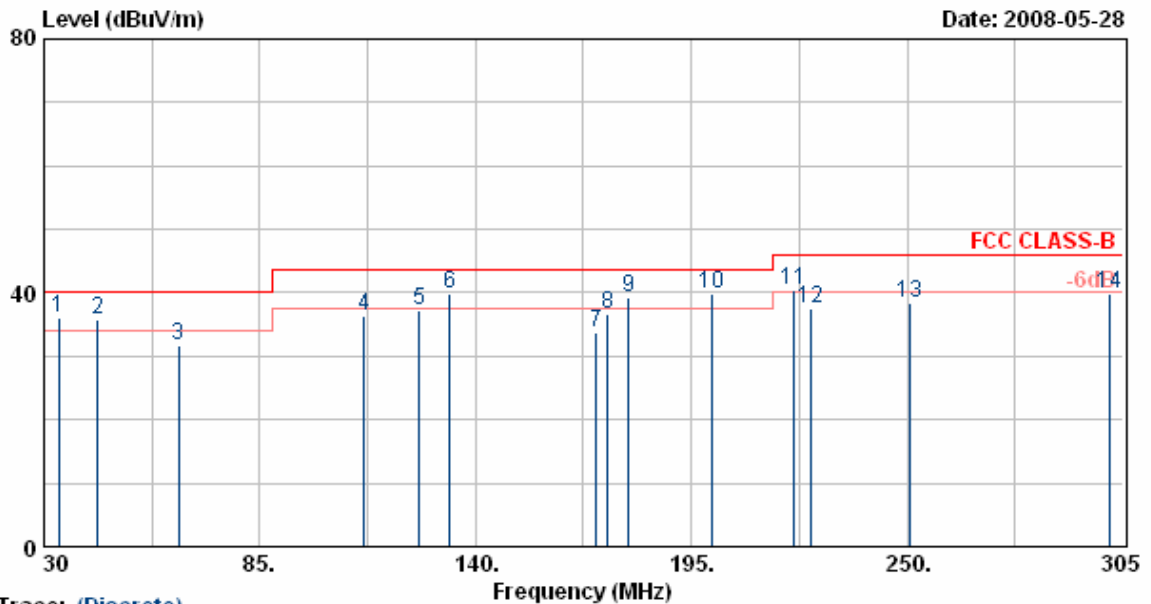

Trace: (Discrete)

Item	Freq	Read Value	Factor	Result	Limit	Margin	Remark	Ant Pos	Tab Pos
	MHz	dBuV/m	dB	dBuV/m	dBuV/m	dB		cm	Deg
1	33.65	43.48	-7.27	36.21	40.00	-3.79	QP	100	78
2	43.81	48.96	-13.13	35.83	40.00	-4.17	QP	100	210
3	64.29	50.76	-18.93	31.83	40.00	-8.17	Peak	100	210
4	111.60	49.57	-13.16	36.41	43.50	-7.09	Peak	100	179
5	125.58	50.68	-13.50	37.18	43.50	-6.32	Peak	100	179
6	133.34	55.18	-15.27	39.91	43.50	-3.59	QP	100	0
7	170.80	45.81	-11.96	33.85	43.50	-9.65	Peak	100	15
8	173.64	47.25	-10.47	36.78	43.50	-6.72	Peak	100	80
9	178.91	48.70	-9.41	39.29	43.50	-4.21	QP	100	111
10	200.02	51.65	-11.75	39.90	43.50	-3.60	QP	100	174
11	220.89	53.86	-13.34	40.52	46.00	-5.48	QP	100	69
12	225.48	49.80	-12.16	37.64	46.00	-8.36	Peak	100	69
13	250.59	51.20	-12.66	38.54	46.00	-7.46	Peak	100	69
14	301.40	49.00	-9.10	39.90	46.00	-6.10	Peak	100	78

Notes:

1. Result = Read Value + Factor
2. Factor = Antenna Factor + Cable Loss - Amplifier
3. The resolution bandwidth of test receiver/spectrum analyzer is 120KHz and video bandwidth is 300kHz for Peak detection and Quasi-peak detection at frequency below 1GHz.
4. All emission below 1GHz at 802.11b/g mode are all the same, so the 802.11g mode chosen as representative in final test.
5. According to technical experiences, all spurious emission of 802.11g mode at channel 1,6,11 are almost the same below 1GHz, so that the channel 1 was chosen as representative in final test.
6. The data is worse case.

Power	: AC 120V	Pol/Phase	: VERTICAL
Test Mode 3	: Transmit / Receive	Temperature	: 25 °C
Operation Channel	: 1	Humidity	: 65 %
Modulation Type	: 802.11g	Atmospheric Pressure	: 1020 hPa
Memo	: MT12-Y120100-A1	Rate	: 54Mbps

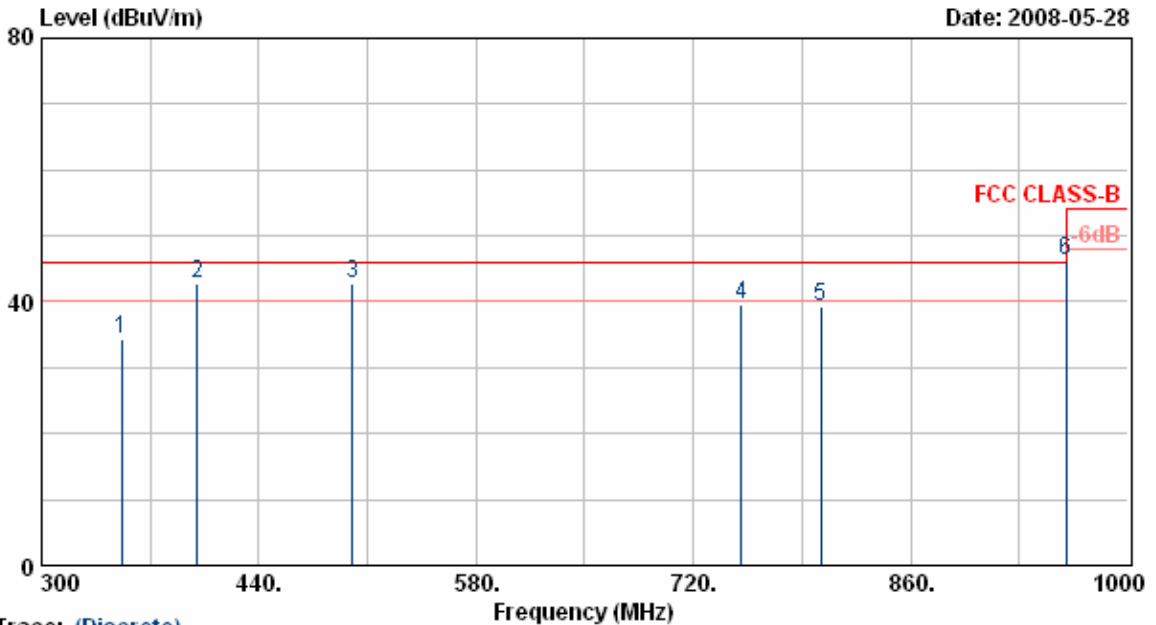

Trace: (Discrete)

Item	Freq	Read Value	Factor	Result	Limit	Margin	Remark	Ant Pos	Tab Pos
	MHz	dBuV/m	dB	dBuV/m	dBuV/m	dB		cm	Deg
1	351.80	44.90	-10.65	34.25	46.00	-11.75	Peak	100	44
2	400.03	51.49	-8.84	42.65	46.00	-3.35	QP	100	98
3	500.07	47.69	-4.86	42.83	46.00	-3.17	QP	100	162
4	750.80	38.58	1.04	39.62	46.00	-6.38	Peak	100	199
5	802.00	42.00	-2.78	39.22	46.00	-6.78	Peak	100	199
6	960.01	43.19	3.19	46.38	54.00	-7.62	Peak	100	0

Notes:

1. Result = Read Value + Factor
2. Factor = Antenna Factor + Cable Loss - Amplifier
3. The resolution bandwidth of test receiver/spectrum analyzer is 120KHz and video bandwidth is 300kHz for Peak detection and Quasi-peak detection at frequency below 1GHz.
4. All emission below 1GHz at 802.11b/g mode are all the same, so the 802.11g mode chosen as representative in final test.
5. According to technical experiences, all spurious emission of 802.11g mode at channel 1,6,11 are almost the same below 1GHz, so that the channel 1 was chosen as representative in final test.
6. The data is worse case.

Power	: AC 120V	Pol/Phase	: HORIZONTAL
Test Mode 3	: Transmit / Receive	Temperature	: 25 °C
Operation Channel	: 1	Humidity	: 65 %
Modulation Type	: 802.11g	Atmospheric Pressure	: 1020 hPa
Memo	: MT12-Y120100-A1	Rate	: 54Mbps

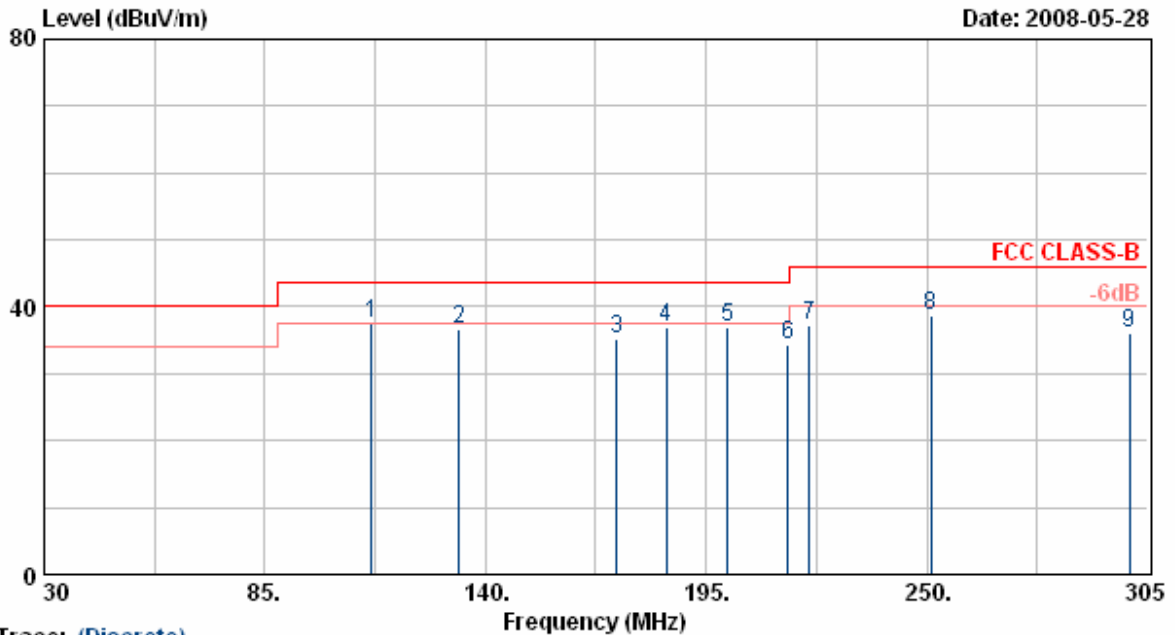

Trace: (Discrete)

Item	Freq	Read Value	Factor	Result	Limit	Margin	Remark	Ant Pos	Tab Pos
	MHz	dBuV/m	dB	dBuV/m	dBuV/m	dB		cm	Deg
1	111.68	56.68	-19.23	37.45	43.50	-6.05	Peak	200	48
2	133.33	56.16	-19.48	36.68	43.50	-6.82	Peak	200	48
3	172.73	53.16	-17.85	35.31	43.50	-8.19	Peak	200	142
4	185.10	54.62	-17.81	36.81	43.50	-6.69	Peak	200	139
5	200.25	51.40	-14.59	36.81	43.50	-6.69	Peak	200	139
6	215.35	52.71	-18.46	34.25	43.50	-9.25	Peak	200	0
7	220.85	55.39	-18.10	37.29	46.00	-8.71	Peak	200	20
8	251.10	56.00	-17.31	38.69	46.00	-7.31	Peak	200	20
9	300.60	50.41	-14.43	35.98	46.00	-10.02	Peak	200	20

Notes:

1. Result = Read Value + Factor
2. Factor = Antenna Factor + Cable Loss - Amplifier
3. The resolution bandwidth of test receiver/spectrum analyzer is 120KHz and video bandwidth is 300kHz for Peak detection and Quasi-peak detection at frequency below 1GHz.
4. All emission below 1GHz at 802.11b/g mode are all the same,so the 802.11g mode chosen as representative in final test.
5. According to technical experiences,all spurious emission of 802.11g mode at channel 1,6,11 are almost the same below 1GHz,so that the channel 1 was chosen as representative in final test.
6. The data is worse case.

Power	: AC 120V	Pol/Phase	: HORIZONTAL
Test Mode 3	: Transmit / Receive	Temperature	: 25 °C
Operation Channel	: 1	Humidity	: 65 %
Modulation Type	: 802.11g	Atmospheric Pressure	: 1020 hPa
Memo	: MT12-Y120100-A1	Rate	: 54Mbps

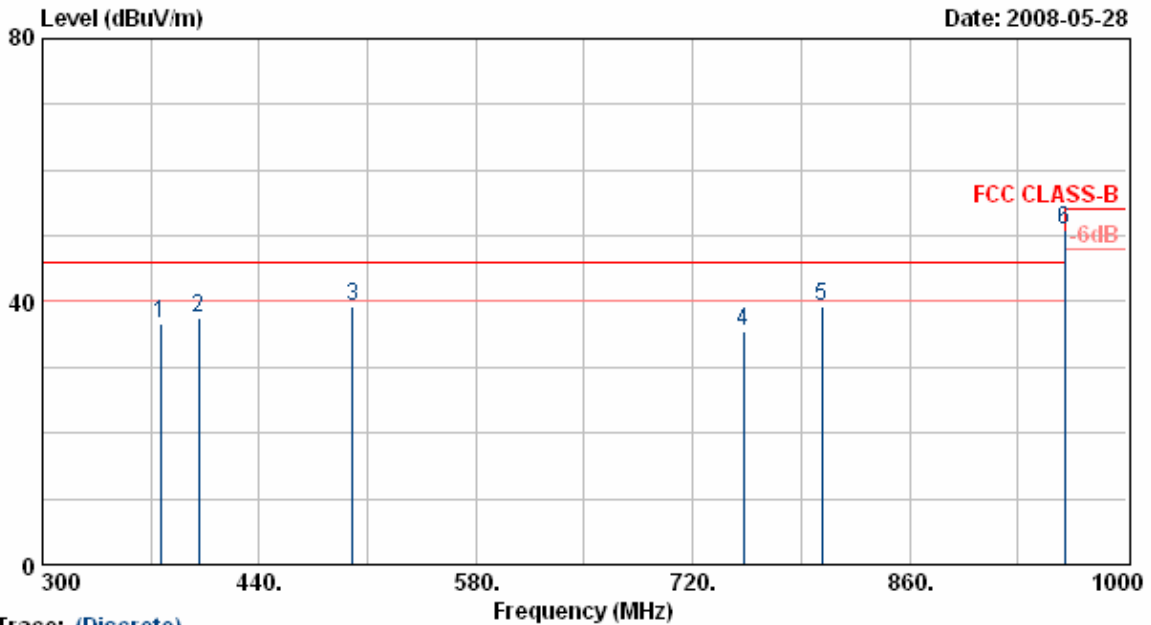

Trace: (Discrete)

Item	Freq	Read Value	Factor	Result	Limit	Margin	Remark	Ant Pos	Tab Pos
	MHz	dBuV/m	dB	dBuV/m	dBuV/m	dB		cm	Deg
1	376.30	47.58	-10.87	36.71	46.00	-9.29	Peak	200	79
2	400.80	48.76	-11.10	37.66	46.00	-8.34	Peak	200	198
3	500.20	43.59	-4.27	39.32	46.00	-6.68	Peak	200	251
4	752.90	35.62	-0.03	35.59	46.00	-10.41	Peak	200	211
5	803.30	39.66	-0.29	39.37	46.00	-6.63	Peak	200	251
6	960.05	44.49	6.33	50.82	54.00	-3.18	QP	200	0

Notes:

1. Result = Read Value + Factor
2. Factor = Antenna Factor + Cable Loss - Amplifier
3. The resolution bandwidth of test receiver/spectrum analyzer is 120KHz and video bandwidth is 300kHz for Peak detection and Quasi-peak detection at frequency below 1GHz.
4. All emission below 1GHz at 802.11b/g mode are all the same,so the 802.11g mode chosen as representative in final test.
5. According to technical experiences,all spurious emission of 802.11g mode at channel 1,6,11 are almost the same below 1GHz,so that the channel 1 was chosen as representative in final test.
6. The data is worse case.

Power	: AC 120V	Pol/Phase	: VERTICAL
Test Mode 3	: Transmit / Receive	Temperature	: 25 °C
Operation Channel	: 1	Humidity	: 65 %
Modulation Type	: 802.11b	Atmospheric Pressure	: 1020 hPa
Memo	: MT12-Y120100-A1	Rate	: 11Mbps

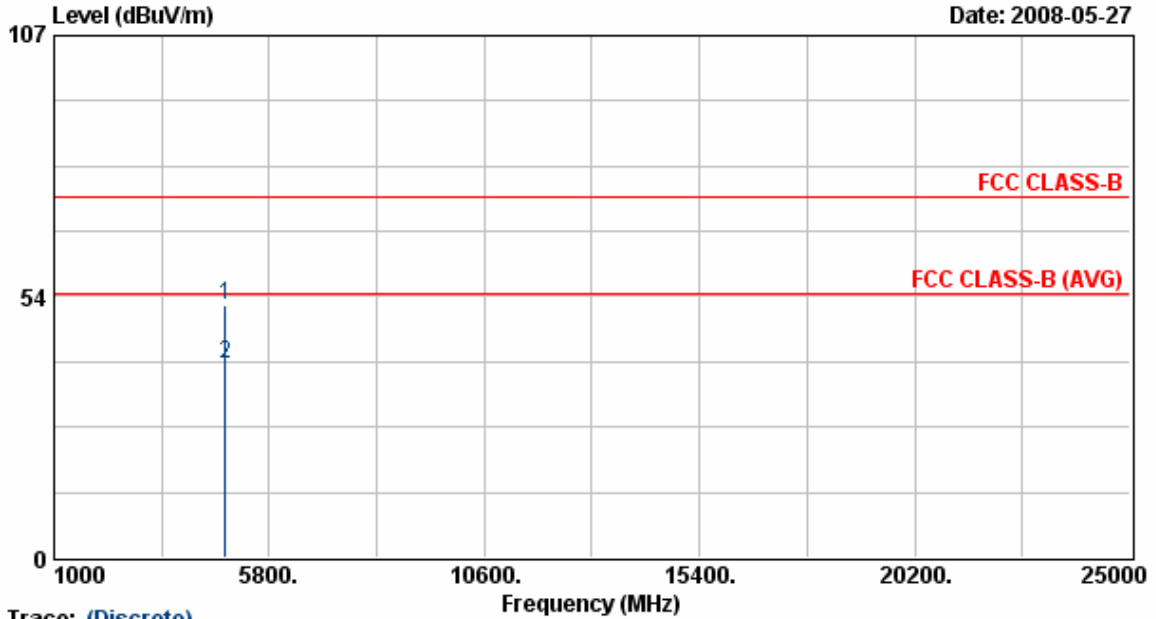

Item	Freq	Read Value	Factor	Result	Limit	Margin	Remark	Ant Pos	Tab Pos
	MHz	dBuV/m	dB	dBuV/m	dBuV/m	dB		cm	Deg
1	4823.85	45.94	5.67	51.61	74.00	-22.39	Peak	100	144
2	4823.85	34.03	5.67	39.71	54.00	-14.29	Average	100	144

Notes:

1. Result = Read Value + Factor
2. Factor = Antenna Factor + Cable Loss - Amplifier
3. The resolution bandwidth of test receiver/spectrum analyzer is 120KHz and video bandwidth is 300kHz for Peak detection and Quasi-peak detection at frequency below 1GHz.
4. The resolution bandwidth of test receiver/spectrum analyzer is 1MHz and video bandwidth is 3MHz for Peak detection at frequency above 1GHz.
5. The resolution bandwidth of test receiver/spectrum analyzer is 1MHz and video bandwidth is 10Hz for Average detection at frequency above 1GHz.
6. The other emissions is too low to be measured.

Power	: AC 120V	Pol/Phase	: HORIZONTAL
Test Mode 3	: Transmit / Receive	Temperature	: 25 °C
Operation Channel	: 1	Humidity	: 65 %
Modulation Type	: 802.11b	Atmospheric Pressure	: 1020 hPa
Memo	: MT12-Y120100-A1	Rate	: 11Mbps

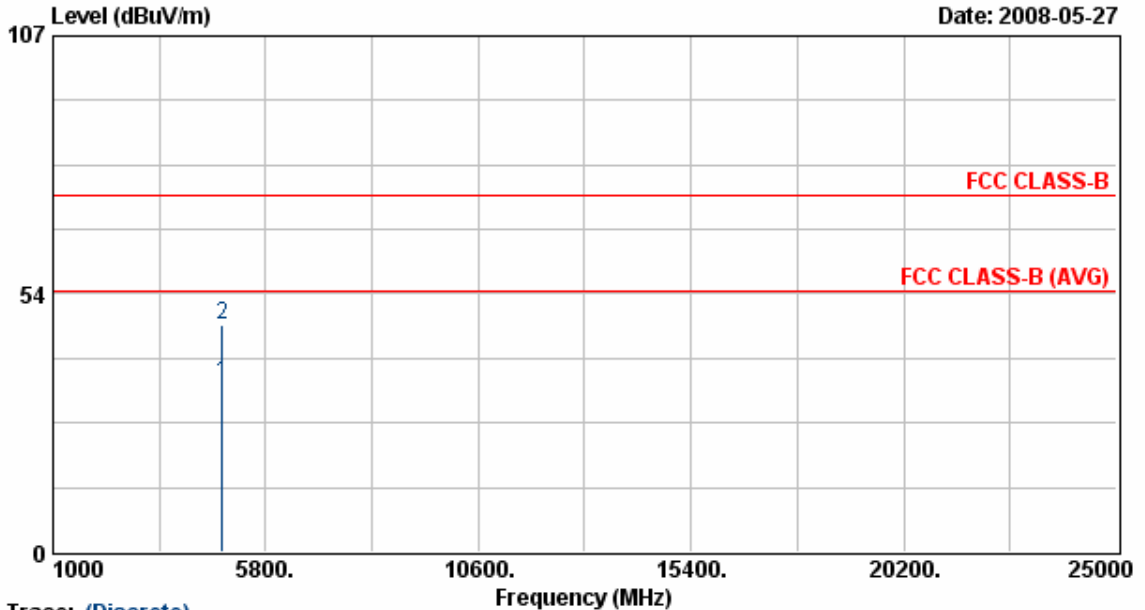

Trace: (Discrete)

Item	Freq	Read Value	Factor	Result	Limit	Margin	Remark	Ant Pos	Tab Pos
	MHz	dBuV/m	dB	dBuV/m	dBuV/m	dB		cm	Deg
1	4823.88	29.38	5.67	35.05	54.00	-18.95	Average	100	241
2	4823.88	41.37	5.67	47.04	74.00	-26.96	Peak	100	241

Notes:

1. Result = Read Value + Factor
2. Factor = Antenna Factor + Cable Loss - Amplifier
3. The resolution bandwidth of test receiver/spectrum analyzer is 120KHz and video bandwidth is 300kHz for Peak detection and Quasi-peak detection at frequency below 1GHz.
4. The resolution bandwidth of test receiver/spectrum analyzer is 1MHz and video bandwidth is 3MHz for Peak detection at frequency above 1GHz.
5. The resolution bandwidth of test receiver/spectrum analyzer is 1MHz and video bandwidth is 10Hz for Average detection at frequency above 1GHz.
6. The other emissions is too low to be measured.

Power	: AC 120V	Pol/Phase	: VERTICAL
Test Mode 3	: Transmit / Receive	Temperature	: 25 °C
Operation Channel	: 6	Humidity	: 65 %
Modulation Type	: 802.11b	Atmospheric Pressure	: 1020 hPa
Memo	: MT12-Y120100-A1	Rate	: 11Mbps

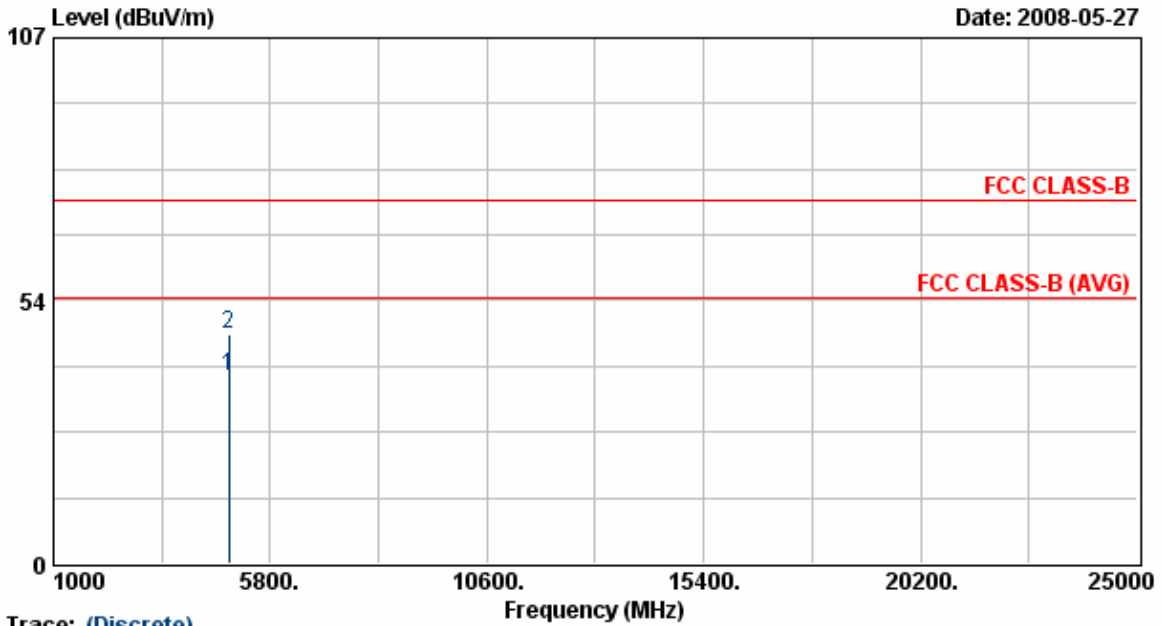

Trace: (Discrete)

Item	Freq	Read Value	Factor	Result	Limit	Margin	Remark	Ant Pos	Tab Pos
	MHz	dBuV/m	dB	dBuV/m	dBuV/m	dB		cm	Deg
1	4873.98	32.52	5.80	38.32	54.00	-15.68	Average	100	144
2	4873.98	41.00	5.80	46.80	74.00	-27.20	Peak	100	144

Notes:

1. Result = Read Value + Factor
2. Factor = Antenna Factor + Cable Loss - Amplifier
3. The resolution bandwidth of test receiver/spectrum analyzer is 120KHz and video bandwidth is 300kHz for Peak detection and Quasi-peak detection at frequency below 1GHz.
4. The resolution bandwidth of test receiver/spectrum analyzer is 1MHz and video bandwidth is 3MHz for Peak detection at frequency above 1GHz.
5. The resolution bandwidth of test receiver/spectrum analyzer is 1MHz and video bandwidth is 10Hz for Average detection at frequency above 1GHz.
6. The other emissions is too low to be measured.

Power	: AC 120V	Pol/Phase	: HORIZONTAL
Test Mode 3	: Transmit / Receive	Temperature	: 25 °C
Operation Channel	: 6	Humidity	: 65 %
Modulation Type	: 802.11b	Atmospheric Pressure	: 1020 hPa
Memo	: MT12-Y120100-A1	Rate	: 11Mbps

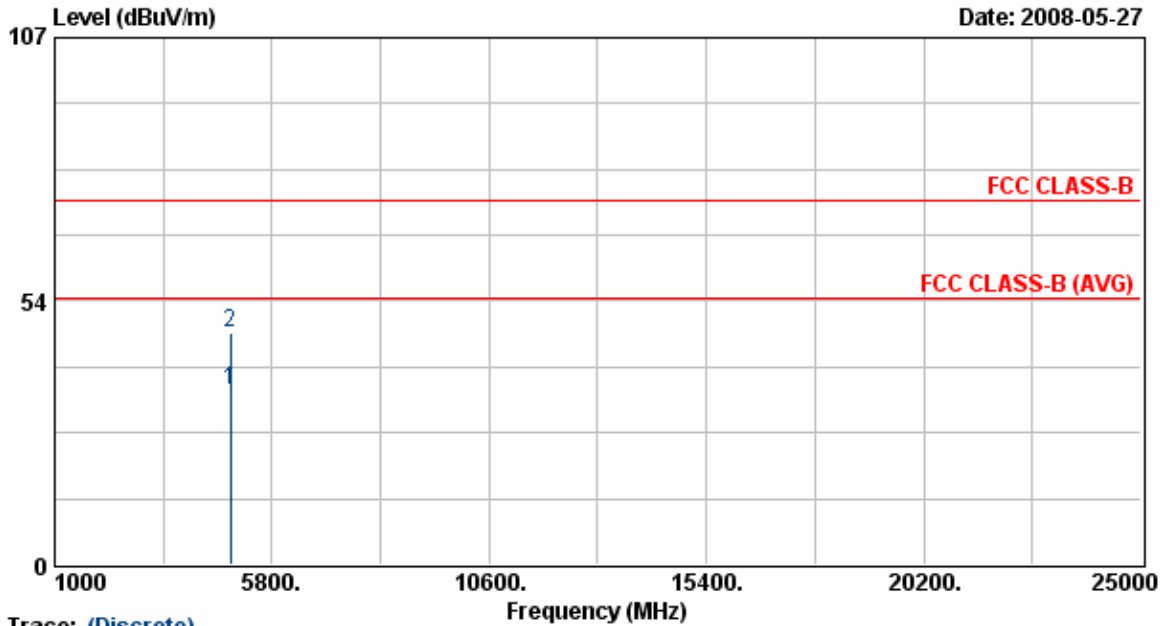

Trace: (Discrete)

Item	Freq	Read Value	Factor	Result	Limit	Margin	Remark	Ant Pos	Tab Pos
	MHz	dBuV/m	dB	dBuV/m	dBuV/m	dB		cm	Deg
1	4874.03	29.48	5.80	35.28	54.00	-18.72	Average	100	241
2	4874.03	41.38	5.80	47.18	74.00	-26.82	Peak	100	241

Notes:

1. Result = Read Value + Factor
2. Factor = Antenna Factor + Cable Loss - Amplifier
3. The resolution bandwidth of test receiver/spectrum analyzer is 120KHz and video bandwidth is 300kHz for Peak detection and Quasi-peak detection at frequency below 1GHz.
4. The resolution bandwidth of test receiver/spectrum analyzer is 1MHz and video bandwidth is 3MHz for Peak detection at frequency above 1GHz.
5. The resolution bandwidth of test receiver/spectrum analyzer is 1MHz and video bandwidth is 10Hz for Average detection at frequency above 1GHz.
6. The other emissions is too low to be measured.

Power	: AC 120V	Pol/Phase	: VERTICAL
Test Mode 3	: Transmit / Receive	Temperature	: 25 °C
Operation Channel	: 11	Humidity	: 65 %
Modulation Type	: 802.11b	Atmospheric Pressure	: 1020 hPa
Memo	: MT12-Y120100-A1	Rate	: 11Mbps

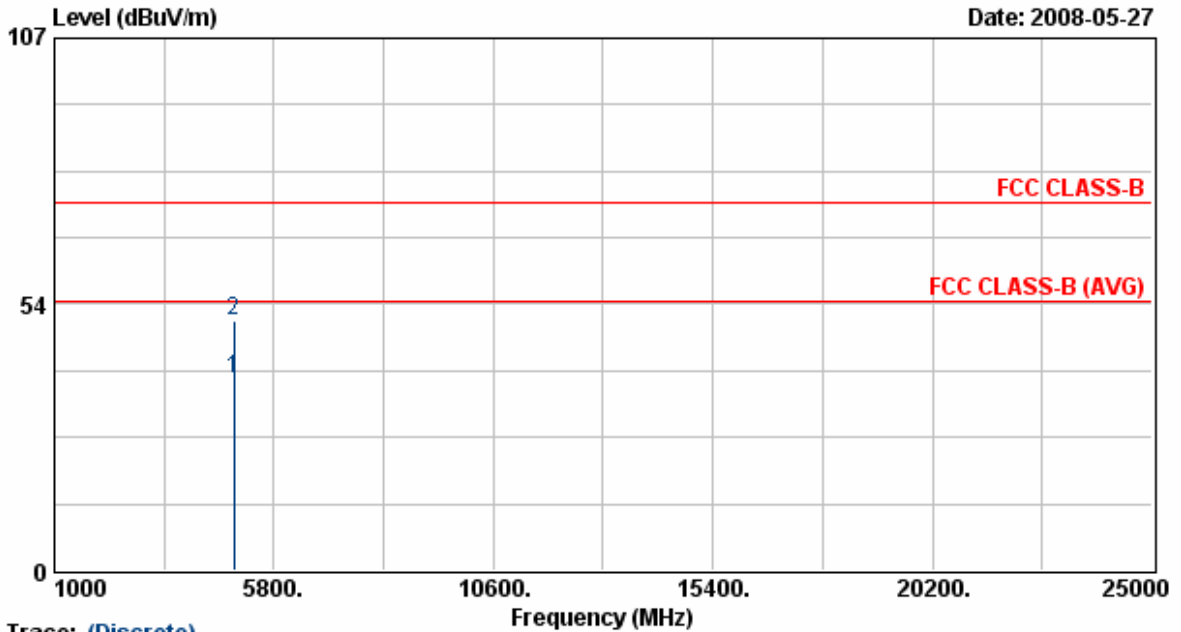

Trace: (Discrete)

Item	Freq	Read Value	Factor	Result	Limit	Margin	Remark	Ant Pos	Tab Pos
	MHz	dBuV/m	dB	dBuV/m	dBuV/m	dB		cm	Deg
1	4923.98	32.56	5.93	38.49	54.00	-15.51	Average	100	144
2	4923.98	44.39	5.93	50.32	74.00	-23.68	Peak	100	144

Notes:

1. Result = Read Value + Factor
2. Factor = Antenna Factor + Cable Loss - Amplifier
3. The resolution bandwidth of test receiver/spectrum analyzer is 120KHz and video bandwidth is 300kHz for Peak detection and Quasi-peak detection at frequency below 1GHz.
4. The resolution bandwidth of test receiver/spectrum analyzer is 1MHz and video bandwidth is 3MHz for Peak detection at frequency above 1GHz.
5. The resolution bandwidth of test receiver/spectrum analyzer is 1MHz and video bandwidth is 10Hz for Average detection at frequency above 1GHz.
6. The other emissions is too low to be measured.

Power	: AC 120V	Pol/Phase	: HORIZONTAL
Test Mode 3	: Transmit / Receive	Temperature	: 25 °C
Operation Channel	: 11	Humidity	: 65 %
Modulation Type	: 802.11b	Atmospheric Pressure	: 1020 hPa
Memo	: MT12-Y120100-A1	Rate	: 11Mbps

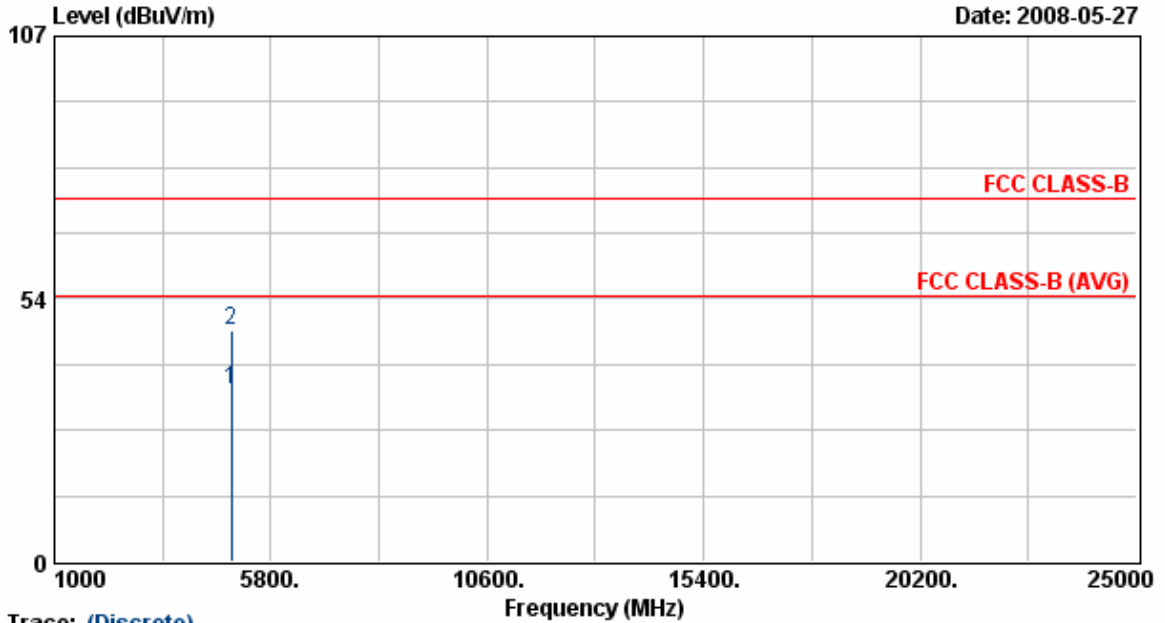

Trace: (Discrete)

Item	Freq	Read Value	Factor	Result	Limit	Margin	Remark	Ant Pos	Tab Pos
	MHz	dBuV/m	dB	dBuV/m	dBuV/m	dB		cm	Deg
1	4923.73	29.20	5.93	35.13	54.00	-18.87	Average	100	241
2	4923.73	41.07	5.93	47.00	74.00	-27.00	Peak	100	241

Notes:

1. Result = Read Value + Factor
2. Factor = Antenna Factor + Cable Loss - Amplifier
3. The resolution bandwidth of test receiver/spectrum analyzer is 120KHz and video bandwidth is 300kHz for Peak detection and Quasi-peak detection at frequency below 1GHz.
4. The resolution bandwidth of test receiver/spectrum analyzer is 1MHz and video bandwidth is 3MHz for Peak detection at frequency above 1GHz.
5. The resolution bandwidth of test receiver/spectrum analyzer is 1MHz and video bandwidth is 10Hz for Average detection at frequency above 1GHz.
6. The other emissions is too low to be measured.

Power	: AC 120V	Pol/Phase	: VERTICAL
Test Mode 3	: Transmit / Receive	Temperature	: 25 °C
Operation Channel	: 1	Humidity	: 65 %
Modulation Type	: 802.11g	Atmospheric Pressure	: 1020 hPa
Memo	: MT12-Y120100-A1	Rate	: 54Mbps

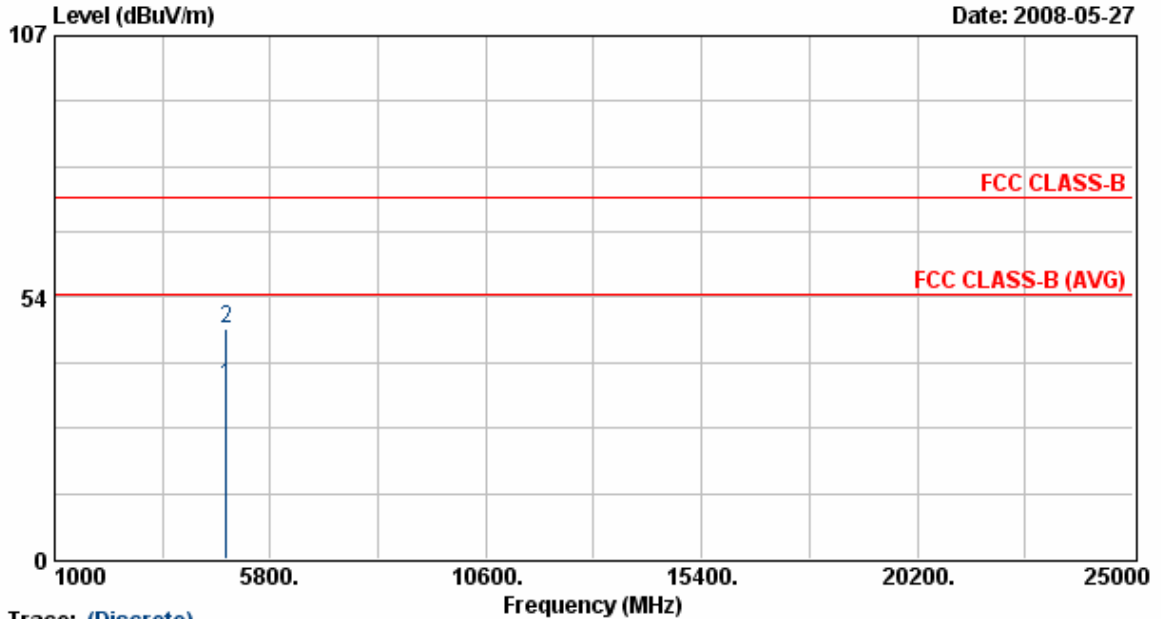

Trace: (Discrete)

Item	Freq	Read Value	Factor	Result	Limit	Margin	Remark	Ant Pos	Tab Pos
	MHz	dBuV/m	dB	dBuV/m	dBuV/m	dB		cm	Deg
1	4823.78	29.66	5.67	35.33	54.00	-18.67	Average	100	144
2	4823.78	41.36	5.67	47.03	74.00	-26.97	Peak	100	144

Notes:

1. Result = Read Value + Factor
2. Factor = Antenna Factor + Cable Loss - Amplifier
3. The resolution bandwidth of test receiver/spectrum analyzer is 120KHz and video bandwidth is 300kHz for Peak detection and Quasi-peak detection at frequency below 1GHz.
4. The resolution bandwidth of test receiver/spectrum analyzer is 1MHz and video bandwidth is 3MHz for Peak detection at frequency above 1GHz.
5. The resolution bandwidth of test receiver/spectrum analyzer is 1MHz and video bandwidth is 10Hz for Average detection at frequency above 1GHz.
6. The other emissions is too low to be measured.

Power	: AC 120V	Pol/Phase	: HORIZONTAL
Test Mode 3	: Transmit / Receive	Temperature	: 25 °C
Operation Channel	: 1	Humidity	: 65 %
Modulation Type	: 802.11g	Atmospheric Pressure	: 1020 hPa
Memo	: MT12-Y120100-A1	Rate	: 54Mbps

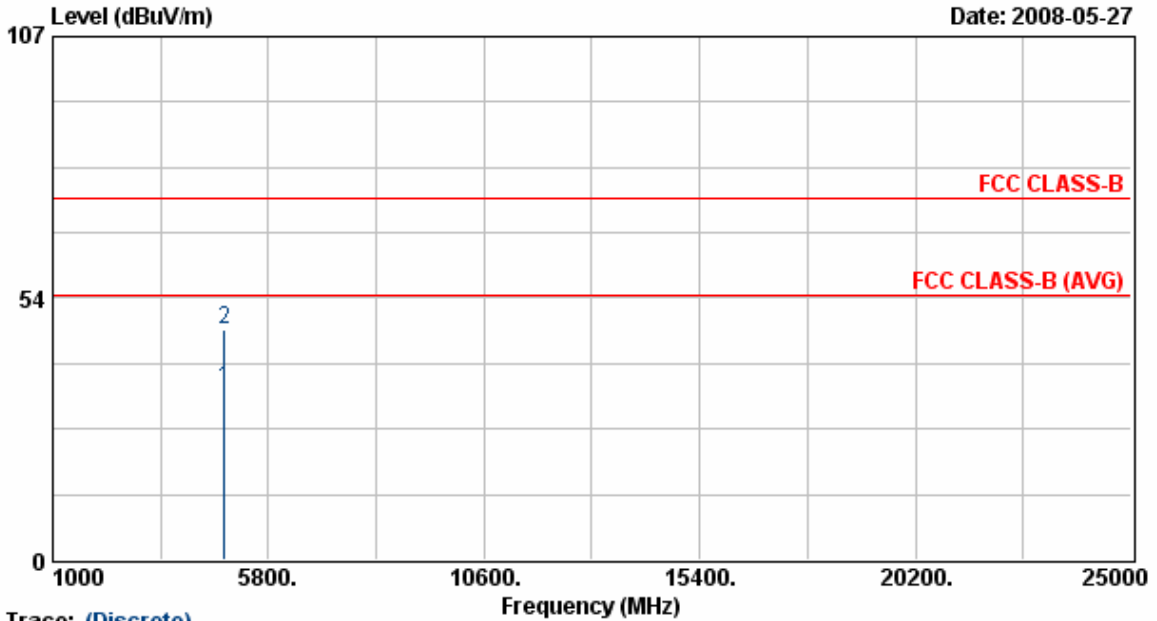

Trace: (Discrete)

Item	Freq	Read Value	Factor	Result	Limit	Margin	Remark	Ant Pos	Tab Pos
	MHz	dBuV/m	dB	dBuV/m	dBuV/m	dB		cm	Deg
1	4824.00	29.34	5.67	35.01	54.00	-18.99	Average	100	241
2	4824.00	41.23	5.67	46.91	74.00	-27.09	Peak	100	241

Notes:

1. Result = Read Value + Factor
2. Factor = Antenna Factor + Cable Loss - Amplifier
3. The resolution bandwidth of test receiver/spectrum analyzer is 120KHz and video bandwidth is 300kHz for Peak detection and Quasi-peak detection at frequency below 1GHz.
4. The resolution bandwidth of test receiver/spectrum analyzer is 1MHz and video bandwidth is 3MHz for Peak detection at frequency above 1GHz.
5. The resolution bandwidth of test receiver/spectrum analyzer is 1MHz and video bandwidth is 10Hz for Average detection at frequency above 1GHz.
6. The other emissions is too low to be measured.

Power	: AC 120V	Pol/Phase	: VERTICAL
Test Mode 3	: Transmit / Receive	Temperature	: 25 °C
Operation Channel	: 6	Humidity	: 65 %
Modulation Type	: 802.11g	Atmospheric Pressure	: 1020 hPa
Memo	: MT12-Y120100-A1	Rate	: 54Mbps

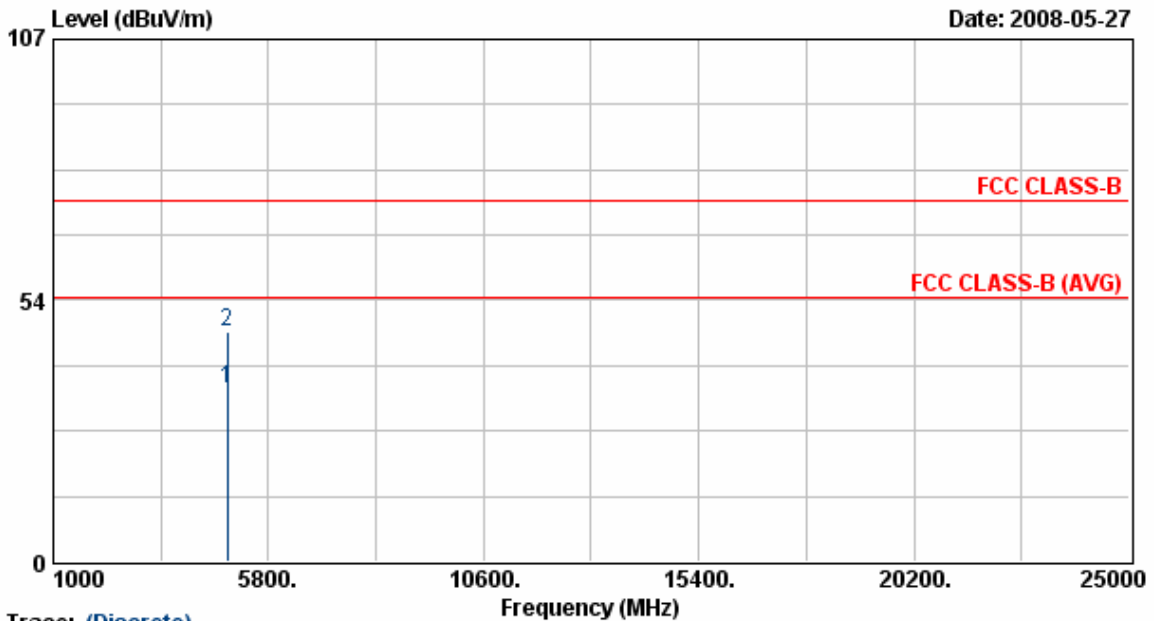

Trace: (Discrete)

Item	Freq	Read Value	Factor	Result	Limit	Margin	Remark	Ant Pos	Tab Pos
	MHz	dBuV/m	dB	dBuV/m	dBuV/m	dB		cm	Deg
1	4873.78	29.68	5.80	35.48	54.00	-18.52	Average	100	144
2	4873.78	41.47	5.80	47.27	74.00	-26.73	Peak	100	144

Notes:

1. Result = Read Value + Factor
2. Factor = Antenna Factor + Cable Loss - Amplifier
3. The resolution bandwidth of test receiver/spectrum analyzer is 120KHz and video bandwidth is 300kHz for Peak detection and Quasi-peak detection at frequency below 1GHz.
4. The resolution bandwidth of test receiver/spectrum analyzer is 1MHz and video bandwidth is 3MHz for Peak detection at frequency above 1GHz.
5. The resolution bandwidth of test receiver/spectrum analyzer is 1MHz and video bandwidth is 10Hz for Average detection at frequency above 1GHz.
6. The other emissions is too low to be measured.

Power	: AC 120V	Pol/Phase	: HORIZONTAL
Test Mode 3	: Transmit / Receive	Temperature	: 25 °C
Operation Channel	: 6	Humidity	: 65 %
Modulation Type	: 802.11g	Atmospheric Pressure	: 1020 hPa
Memo	: MT12-Y120100-A1	Rate	: 54Mbps

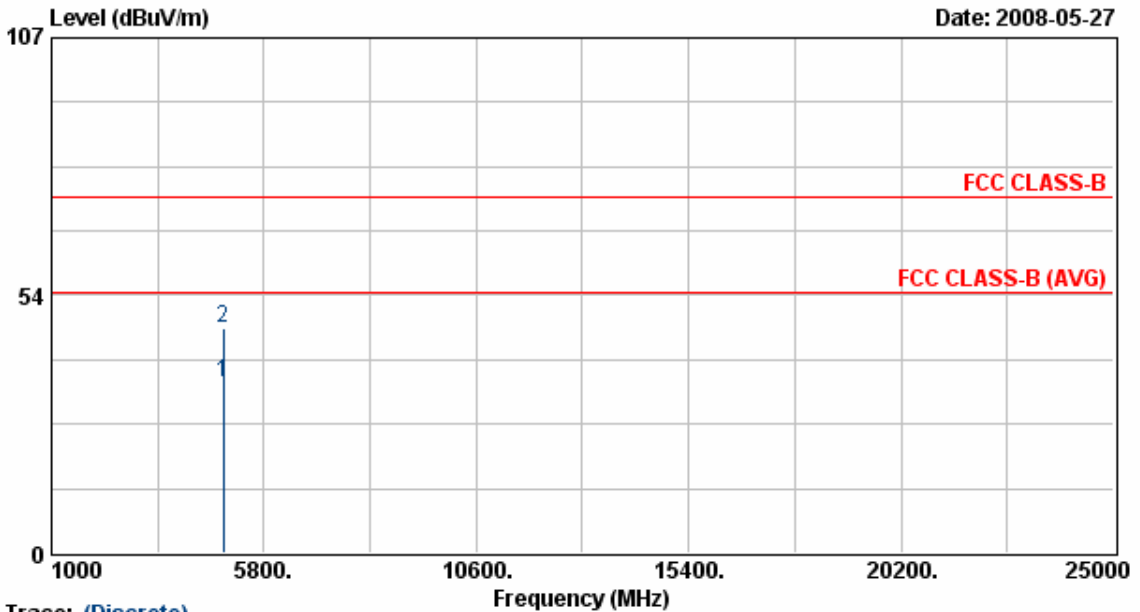

Trace: (Discrete)

Item	Freq	Read Value	Factor	Result	Limit	Margin	Remark	Ant Pos	Tab Pos
	MHz	dBuV/m	dB	dBuV/m	dBuV/m	dB		cm	Deg
1	4874.03	29.46	5.80	35.26	54.00	-18.74	Average	100	241
2	4874.03	41.05	5.80	46.86	74.00	-27.14	Peak	100	241

Notes:

1. Result = Read Value + Factor
2. Factor = Antenna Factor + Cable Loss - Amplifier
3. The resolution bandwidth of test receiver/spectrum analyzer is 120KHz and video bandwidth is 300kHz for Peak detection and Quasi-peak detection at frequency below 1GHz.
4. The resolution bandwidth of test receiver/spectrum analyzer is 1MHz and video bandwidth is 3MHz for Peak detection at frequency above 1GHz.
5. The resolution bandwidth of test receiver/spectrum analyzer is 1MHz and video bandwidth is 10Hz for Average detection at frequency above 1GHz.
6. The other emissions is too low to be measured.

Power	: AC 120V	Pol/Phase	: VERTICAL
Test Mode 3	: Transmit / Receive	Temperature	: 25 °C
Operation Channel	: 11	Humidity	: 65 %
Modulation Type	: 802.11g	Atmospheric Pressure	: 1020 hPa
Memo	: MT12-Y120100-A1	Rate	: 54Mbps

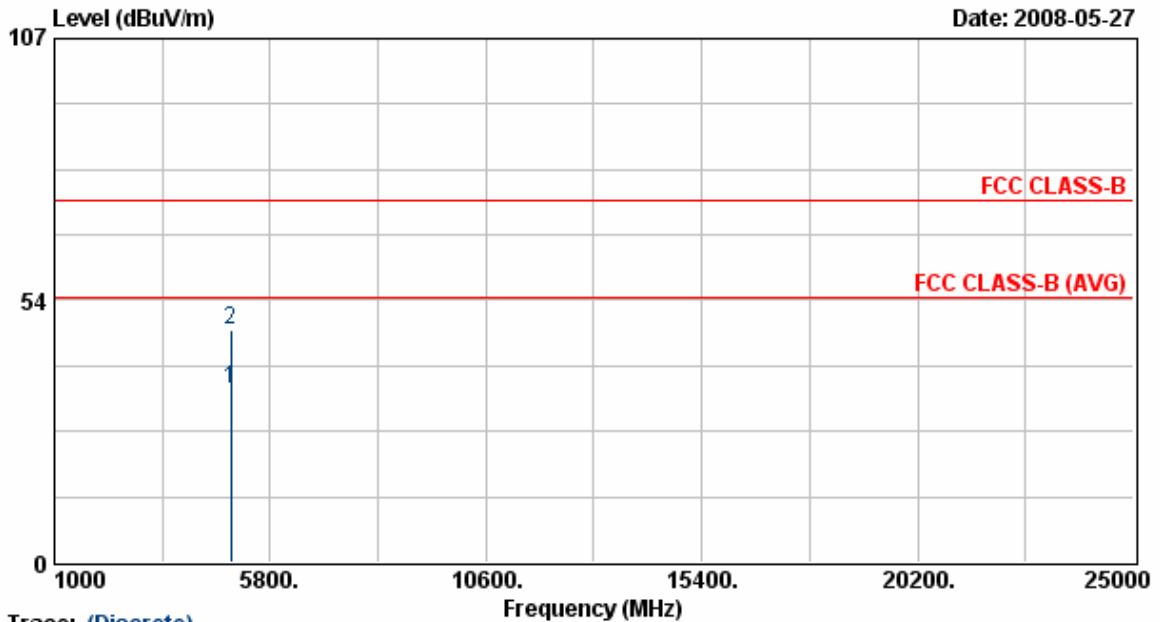

Trace: (Discrete)

Item	Freq	Read Value	Factor	Result	Limit	Margin	Remark	Ant Pos	Tab Pos
	MHz	dBuV/m	dB	dBuV/m	dBuV/m	dB		cm	Deg
1	4924.00	29.57	5.93	35.50	54.00	-18.50	Average	100	144
2	4924.00	41.37	5.93	47.30	74.00	-26.70	Peak	100	144

Notes:

1. Result = Read Value + Factor
2. Factor = Antenna Factor + Cable Loss - Amplifier
3. The resolution bandwidth of test receiver/spectrum analyzer is 120KHz and video bandwidth is 300kHz for Peak detection and Quasi-peak detection at frequency below 1GHz.
4. The resolution bandwidth of test receiver/spectrum analyzer is 1MHz and video bandwidth is 3MHz for Peak detection at frequency above 1GHz.
5. The resolution bandwidth of test receiver/spectrum analyzer is 1MHz and video bandwidth is 10Hz for Average detection at frequency above 1GHz.
6. The other emissions is too low to be measured.

Power	: AC 120V	Pol/Phase	: HORIZONTAL
Test Mode 3	: Transmit / Receive	Temperature	: 25 °C
Operation Channel	: 11	Humidity	: 65 %
Modulation Type	: 802.11g	Atmospheric Pressure	: 1020 hPa
Memo	: MT12-Y120100-A1	Rate	: 54Mbps

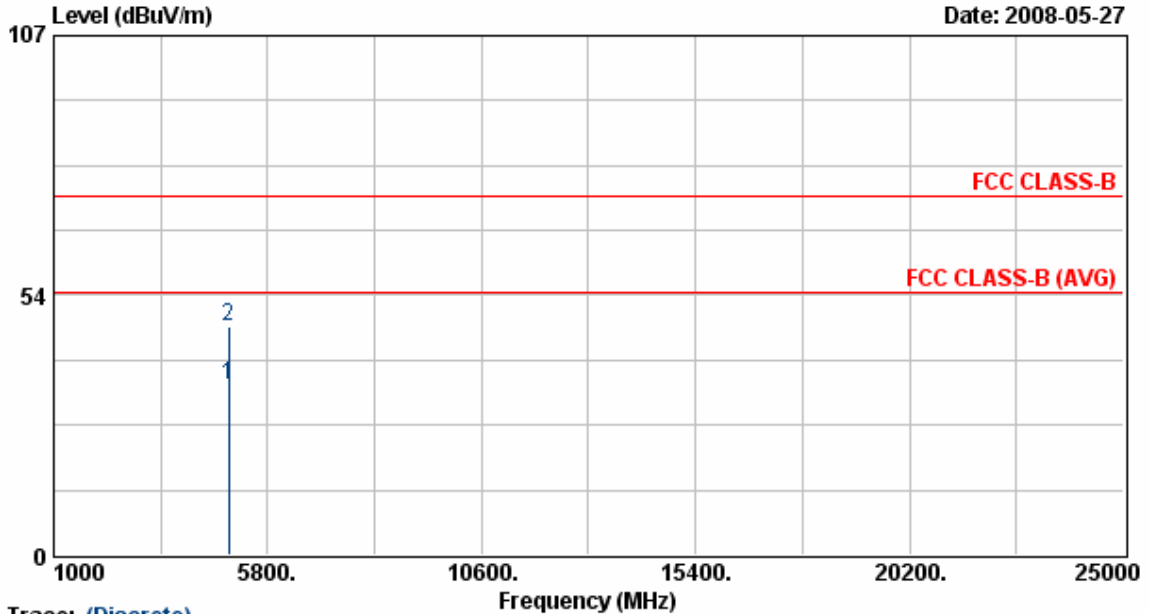

Trace: (Discrete)

Item	Freq	Read Value	Factor	Result	Limit	Margin	Remark	Ant Pos	Tab Pos
	MHz	dBuV/m	dB	dBuV/m	dBuV/m	dB		cm	Deg
1	4923.90	29.14	5.93	35.07	54.00	-18.93	Average	100	241
2	4923.90	41.06	5.93	47.00	74.00	-27.00	Peak	100	241

Notes:

1. Result = Read Value + Factor
2. Factor = Antenna Factor + Cable Loss - Amplifier
3. The resolution bandwidth of test receiver/spectrum analyzer is 120KHz and video bandwidth is 300kHz for Peak detection and Quasi-peak detection at frequency below 1GHz.
4. The resolution bandwidth of test receiver/spectrum analyzer is 1MHz and video bandwidth is 3MHz for Peak detection at frequency above 1GHz.
5. The resolution bandwidth of test receiver/spectrum analyzer is 1MHz and video bandwidth is 10Hz for Average detection at frequency above 1GHz.
6. The other emissions is too low to be measured.

Power	: AC 120V	Pol/Phase	: VERTICAL
Test Mode 3	: Transmit / Receive	Temperature	: 25 °C
Operation Channel	: 1	Humidity	: 65 %
Modulation Type	: 802.11n, HT20	Atmospheric Pressure	: 1020 hPa
Memo	: MT12-Y120100-A1	Rate	: 130Mbps

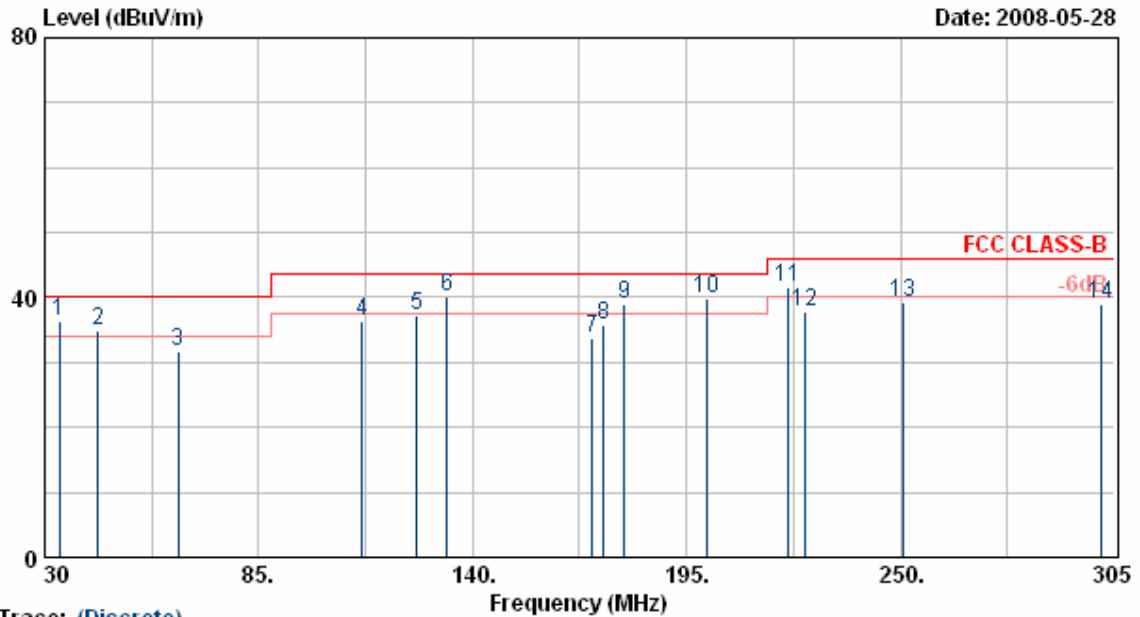

Trace: (Discrete)

Item	Freq MHz	Read Value dBuV/m	Factor dB	Result dBuV/m	Limit dBuV/m	Margin dB	Remark	Ant Pos cm	Tab Pos Deg
1	33.65	43.55	-7.27	36.28	40.00	-3.72	QP	100	78
2	43.81	47.96	-13.13	34.83	40.00	-5.17	QP	100	210
3	64.29	50.69	-18.93	31.76	40.00	-8.24	Peak	100	210
4	111.60	49.42	-13.16	36.26	43.50	-7.24	Peak	100	179
5	125.58	50.60	-13.50	37.10	43.50	-6.40	Peak	100	179
6	133.34	55.55	-15.27	40.28	43.50	-3.22	QP	100	0
7	170.80	45.80	-11.96	33.84	43.50	-9.66	Peak	100	15
8	173.64	46.25	-10.47	35.78	43.50	-7.72	Peak	100	80
9	178.91	48.48	-9.41	39.07	43.50	-4.43	QP	100	111
10	200.02	51.60	-11.75	39.85	43.50	-3.65	QP	100	174
11	220.89	54.86	-13.34	41.52	46.00	-4.48	QP	100	69
12	225.48	49.85	-12.16	37.69	46.00	-8.31	Peak	100	69
13	250.59	51.80	-12.66	39.14	46.00	-6.86	Peak	100	69
14	301.40	48.00	-9.10	38.90	46.00	-7.10	Peak	100	78

Notes:

1. Result = Read Value + Factor
2. Factor = Antenna Factor + Cable Loss - Amplifier
3. The resolution bandwidth of test receiver/spectrum analyzer is 120KHz and video bandwidth is 300kHz for Peak detection and Quasi-peak detection at frequency below 1GHz.
4. According to technical experiences, all spurious emission of 802.11MIMO mode at channel 1,6,11 are almost the same below 1GHz, so that the channel 1 was chosen as representative in final test.
5. The data is worse case.

Power	: AC 120V	Pol/Phase	: VERTICAL
Test Mode 3	: Transmit / Receive	Temperature	: 25 °C
Operation Channel	: 1	Humidity	: 65 %
Modulation Type	: 802.11n, HT20	Atmospheric Pressure	: 1020 hPa
Memo	: MT12-Y120100-A1	Rate	: 130Mbps

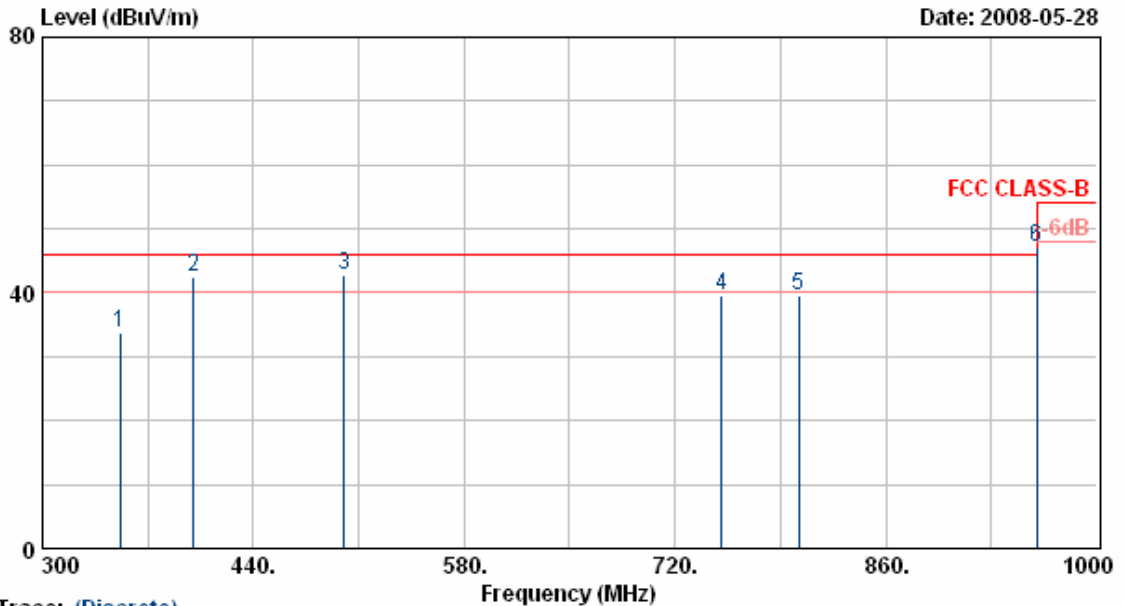

Notes:

1. Result = Read Value + Factor
2. Factor = Antenna Factor + Cable Loss - Amplifier
3. The resolution bandwidth of test receiver/spectrum analyzer is 120KHz and video bandwidth is 300kHz for Peak detection and Quasi-peak detection at frequency below 1GHz.
4. According to technical experiences, all spurious emission of 802.11MIMO mode at channel 1,6,11 are almost the same below 1GHz, so that the channel 1 was chosen as representative in final test.
5. The data is worse case.

Power	: AC 120V	Pol/Phase	: HORIZONTAL
Test Mode 3	: Transmit / Receive	Temperature	: 25 °C
Operation Channel	: 1	Humidity	: 65 %
Modulation Type	: 802.11n, HT20	Atmospheric Pressure	: 1020 hPa
Memo	: MT12-Y120100-A1	Rate	: 130Mbps

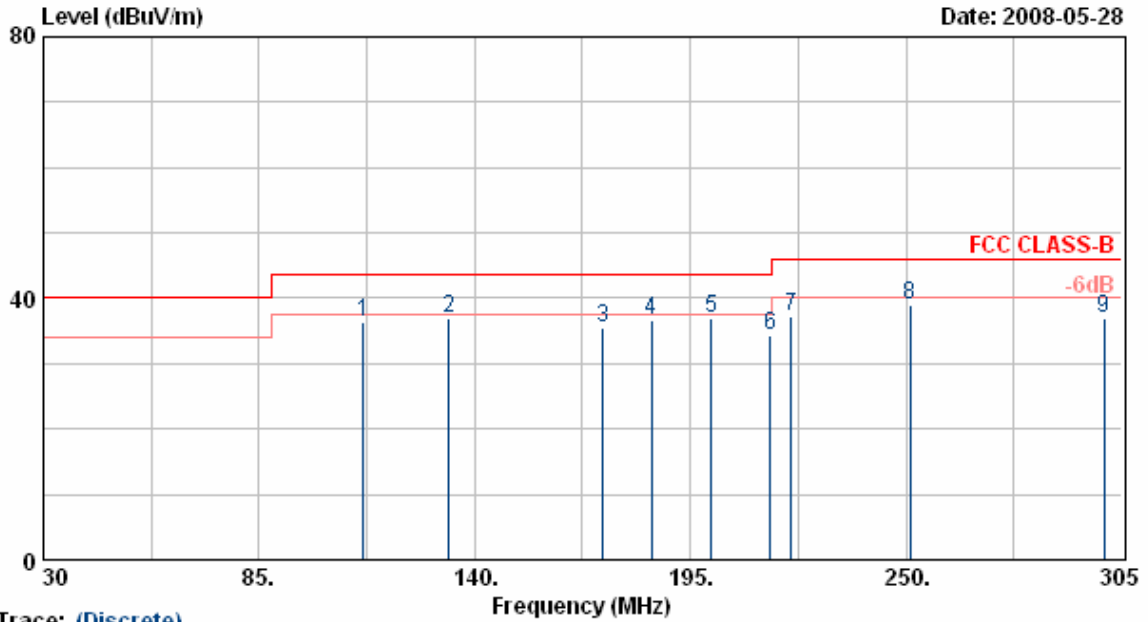

Trace: (Discrete)

Item	Freq	Read Value	Factor	Result	Limit	Margin	Remark	Ant Pos	Tab Pos
	MHz	dBuV/m	dB	dBuV/m	dBuV/m	dB		cm	Deg
1	111.68	55.68	-19.23	36.45	43.50	-7.05	Peak	200	48
2	133.33	56.50	-19.48	37.02	43.50	-6.48	Peak	200	48
3	172.73	53.44	-17.85	35.59	43.50	-7.91	Peak	200	142
4	185.10	54.42	-17.81	36.61	43.50	-6.89	Peak	200	139
5	200.25	51.45	-14.59	36.86	43.50	-6.64	Peak	200	139
6	215.35	52.70	-18.46	34.24	43.50	-9.26	Peak	200	0
7	220.85	55.47	-18.10	37.37	46.00	-8.63	Peak	200	20
8	251.10	56.22	-17.31	38.91	46.00	-7.09	Peak	200	20
9	300.60	51.41	-14.43	36.98	46.00	-9.02	Peak	200	20

Notes:

1. Result = Read Value + Factor
2. Factor = Antenna Factor + Cable Loss - Amplifier
3. The resolution bandwidth of test receiver/spectrum analyzer is 120KHz and video bandwidth is 300kHz for Peak detection and Quasi-peak detection at frequency below 1GHz.
4. According to technical experiences, all spurious emission of 802.11MIMO mode at channel 1,6,11 are almost the same below 1GHz, so that the channel 1 was chosen as representative in final test.
5. The data is worse case.

Power	: AC 120V	Pol/Phase	: HORIZONTAL
Test Mode 3	: Transmit / Receive	Temperature	: 25 °C
Operation Channel	: 1	Humidity	: 65 %
Modulation Type	: 802.11n, HT20	Atmospheric Pressure	: 1020 hPa
Memo	: MT12-Y120100-A1	Rate	: 130Mbps

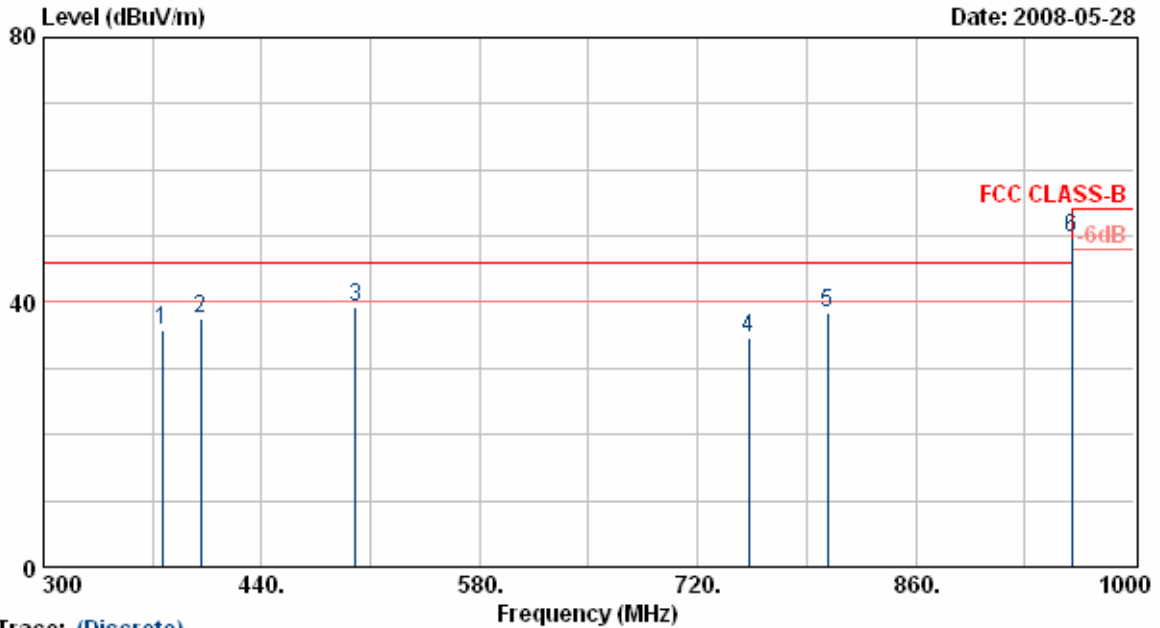

Trace: (Discrete)

Item	Freq	Read Value	Factor	Result	Limit	Margin	Remark	Ant Pos	Tab Pos
	MHz	dBuV/m	dB	dBuV/m	dBuV/m	dB		cm	Deg
1	376.30	46.58	-10.87	35.71	46.00	-10.29	Peak	200	79
2	400.80	48.70	-11.10	37.60	46.00	-8.40	Peak	200	198
3	500.20	43.66	-4.27	39.39	46.00	-6.61	Peak	200	251
4	752.90	34.62	-0.03	34.59	46.00	-11.41	Peak	200	211
5	803.30	38.66	-0.29	38.37	46.00	-7.63	Peak	200	251
6	960.05	43.49	6.33	49.82	54.00	-4.18	QP	200	0

Notes:

1. Result = Read Value + Factor
2. Factor = Antenna Factor + Cable Loss - Amplifier
3. The resolution bandwidth of test receiver/spectrum analyzer is 120KHz and video bandwidth is 300kHz for Peak detection and Quasi-peak detection at frequency below 1GHz.
4. According to technical experiences, all spurious emission of 802.11MIMO mode at channel 1,6,11 are almost the same below 1GHz, so that the channel 1 was chosen as representative in final test.
5. The data is worse case.

Power	: AC 120V	Pol/Phase	: VERTICAL
Test Mode 3	: Transmit / Receive	Temperature	: 25 °C
Operation Channel	: 1	Humidity	: 65 %
Modulation Type	: 802.11n, HT20	Atmospheric Pressure	: 1020 hPa
Memo	: MT12-Y120100-A1	Rate	: 130Mbps

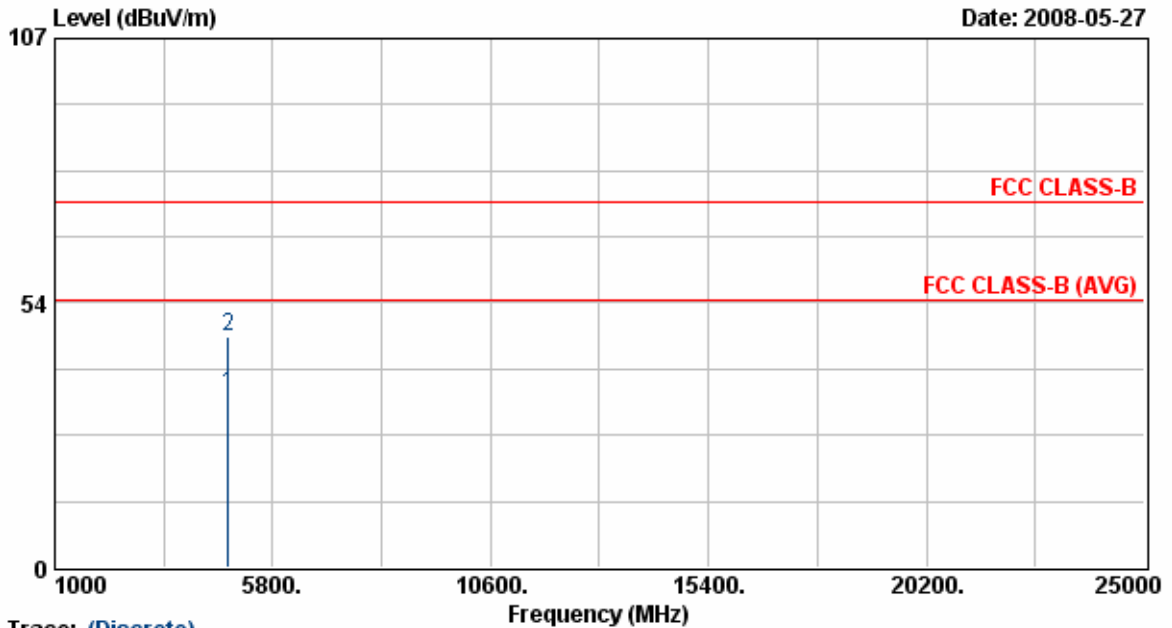

Trace: (Discrete)

Item	Freq	Read Value	Factor	Result	Limit	Margin	Remark	Ant Pos	Tab Pos
	MHz	dBuV/m	dB	dBuV/m	dBuV/m	dB		cm	Deg
1	4824.05	29.44	5.67	35.11	54.00	-18.89	Average	100	144
2	4824.05	41.15	5.67	46.83	74.00	-27.17	Peak	100	144

Notes:

1. Result = Read Value + Factor
2. Factor = Antenna Factor + Cable Loss - Amplifier
3. The resolution bandwidth of test receiver/spectrum analyzer is 120KHz and video bandwidth is 300kHz for Peak detection and Quasi-peak detection at frequency below 1GHz.
4. The resolution bandwidth of test receiver/spectrum analyzer is 1MHz and video bandwidth is 3MHz for Peak detection at frequency above 1GHz.
5. The resolution bandwidth of test receiver/spectrum analyzer is 1MHz and video bandwidth is 10Hz for Average detection at frequency above 1GHz.
6. The other emissions is too low to be measured.

Power	: AC 120V	Pol/Phase	: HORIZONTAL
Test Mode 3	: Transmit / Receive	Temperature	: 25 °C
Operation Channel	: 1	Humidity	: 65 %
Modulation Type	: 802.11n, HT20	Atmospheric Pressure	: 1020 hPa
Memo	: MT12-Y120100-A1	Rate	: 130Mbps

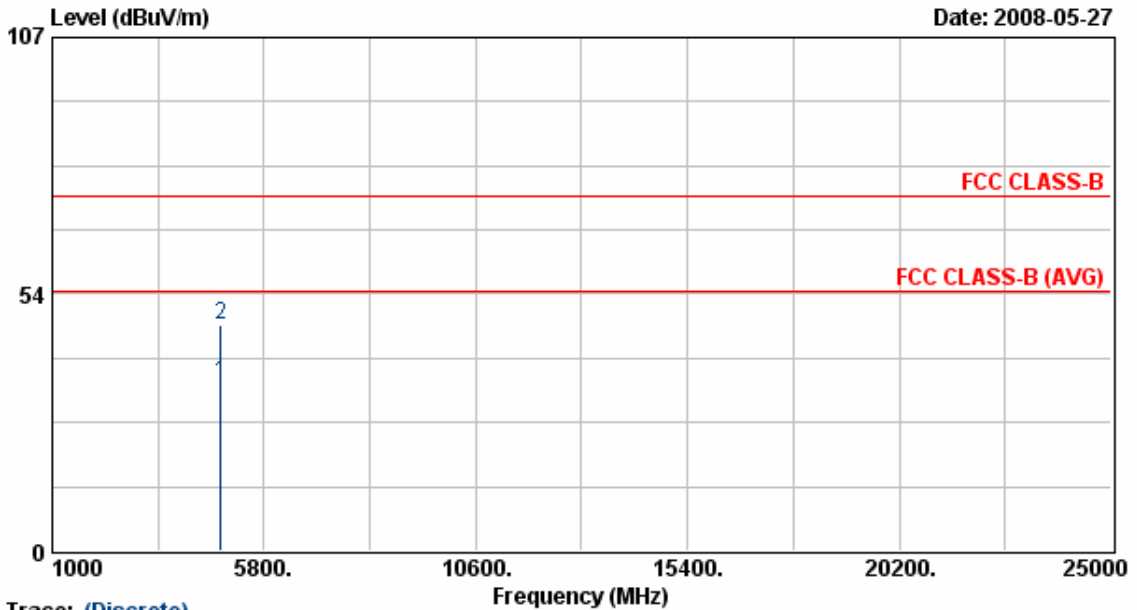

Trace: (Discrete)

Item	Freq	Read Value	Factor	Result	Limit	Margin	Remark	Ant Pos	Tab Pos
	MHz	dBuV/m	dB	dBuV/m	dBuV/m	dB		cm	Deg
1	4824.05	29.33	5.67	35.00	54.00	-19.00	Average	100	241
2	4824.05	41.26	5.67	46.94	74.00	-27.06	Peak	100	241

Notes:

1. Result = Read Value + Factor
2. Factor = Antenna Factor + Cable Loss - Amplifier
3. The resolution bandwidth of test receiver/spectrum analyzer is 120KHz and video bandwidth is 300kHz for Peak detection and Quasi-peak detection at frequency below 1GHz.
4. The resolution bandwidth of test receiver/spectrum analyzer is 1MHz and video bandwidth is 3MHz for Peak detection at frequency above 1GHz.
5. The resolution bandwidth of test receiver/spectrum analyzer is 1MHz and video bandwidth is 10Hz for Average detection at frequency above 1GHz.
6. The other emissions is too low to be measured.

Power	: AC 120V	Pol/Phase	: VERTICAL
Test Mode 3	: Transmit / Receive	Temperature	: 25 °C
Operation Channel	: 6	Humidity	: 65 %
Modulation Type	: 802.11n, HT20	Atmospheric Pressure	: 1020 hPa
Memo	: MT12-Y120100-A1	Rate	: 130Mbps

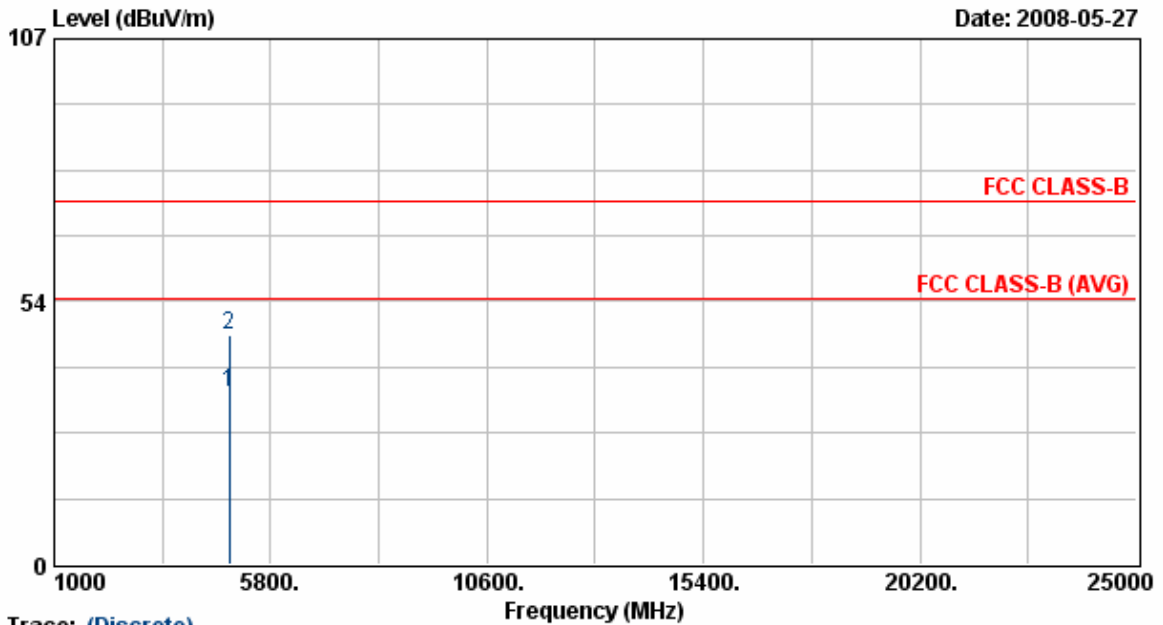

Trace: (Discrete)

Item	Freq	Read Value	Factor	Result	Limit	Margin	Remark	Ant Pos	Tab Pos
	MHz	dBuV/m	dB	dBuV/m	dBuV/m	dB		cm	Deg
1	4874.05	29.24	5.80	35.04	54.00	-18.96	Average	100	144
2	4874.05	41.03	5.80	46.83	74.00	-27.17	Peak	100	144

Notes:

1. Result = Read Value + Factor
2. Factor = Antenna Factor + Cable Loss - Amplifier
3. The resolution bandwidth of test receiver/spectrum analyzer is 120KHz and video bandwidth is 300kHz for Peak detection and Quasi-peak detection at frequency below 1GHz.
4. The resolution bandwidth of test receiver/spectrum analyzer is 1MHz and video bandwidth is 3MHz for Peak detection at frequency above 1GHz.
5. The resolution bandwidth of test receiver/spectrum analyzer is 1MHz and video bandwidth is 10Hz for Average detection at frequency above 1GHz.
6. The other emissions is too low to be measured.

Power	: AC 120V	Pol/Phase	: HORIZONTAL
Test Mode 3	: Transmit / Receive	Temperature	: 25 °C
Operation Channel	: 6	Humidity	: 65 %
Modulation Type	: 802.11n, HT20	Atmospheric Pressure	: 1020 hPa
Memo	: MT12-Y120100-A1	Rate	: 130Mbps

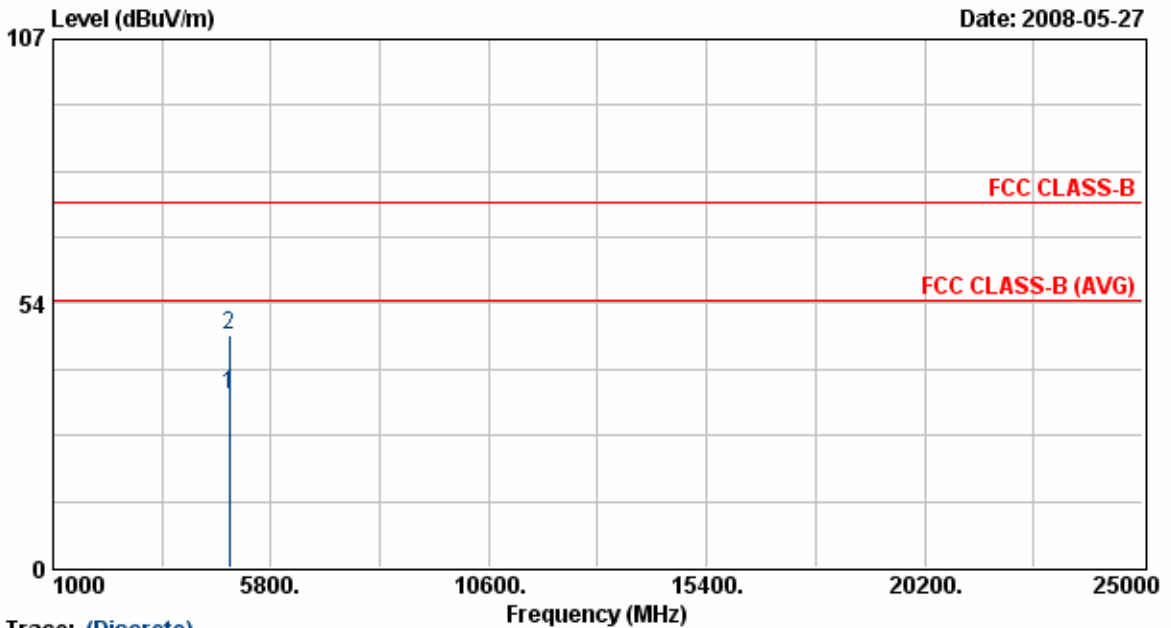

Trace: (Discrete)

Item	Freq	Read Value	Factor	Result	Limit	Margin	Remark	Ant Pos	Tab Pos
	MHz	dBuV/m	dB	dBuV/m	dBuV/m	dB		cm	Deg
1	4874.10	29.37	5.80	35.17	54.00	-18.83	Average	100	241
2	4874.10	41.34	5.80	47.14	74.00	-26.86	Peak	100	241

Notes:

1. Result = Read Value + Factor
2. Factor = Antenna Factor + Cable Loss - Amplifier
3. The resolution bandwidth of test receiver/spectrum analyzer is 120KHz and video bandwidth is 300kHz for Peak detection and Quasi-peak detection at frequency below 1GHz.
4. The resolution bandwidth of test receiver/spectrum analyzer is 1MHz and video bandwidth is 3MHz for Peak detection at frequency above 1GHz.
5. The resolution bandwidth of test receiver/spectrum analyzer is 1MHz and video bandwidth is 10Hz for Average detection at frequency above 1GHz.
6. The other emissions is too low to be measured.

Power	: AC 120V	Pol/Phase	: VERTICAL
Test Mode 3	: Transmit / Receive	Temperature	: 25 °C
Operation Channel	: 11	Humidity	: 65 %
Modulation Type	: 802.11n, HT20	Atmospheric Pressure	: 1020 hPa
Memo	: MT12-Y120100-A1	Rate	: 130Mbps

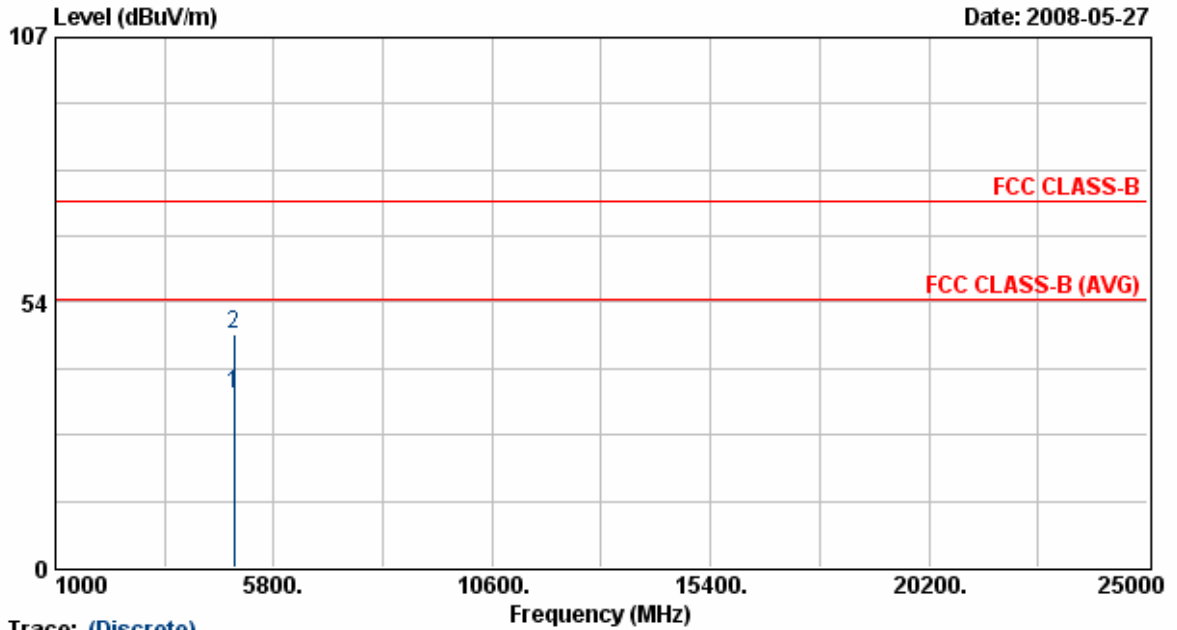

Trace: (Discrete)

Item	Freq	Read Value	Factor	Result	Limit	Margin	Remark	Ant Pos	Tab Pos
	MHz	dBuV/m	dB	dBuV/m	dBuV/m	dB		cm	Deg
1	4923.90	29.23	5.93	35.17	54.00	-18.83	Average	100	144
2	4923.90	41.04	5.93	46.97	74.00	-27.03	Peak	100	144

Notes:

1. Result = Read Value + Factor
2. Factor = Antenna Factor + Cable Loss - Amplifier
3. The resolution bandwidth of test receiver/spectrum analyzer is 120KHz and video bandwidth is 300kHz for Peak detection and Quasi-peak detection at frequency below 1GHz.
4. The resolution bandwidth of test receiver/spectrum analyzer is 1MHz and video bandwidth is 3MHz for Peak detection at frequency above 1GHz.
5. The resolution bandwidth of test receiver/spectrum analyzer is 1MHz and video bandwidth is 10Hz for Average detection at frequency above 1GHz.
6. The other emissions is too low to be measured.

Power	: AC 120V	Pol/Phase	: HORIZONTAL
Test Mode 3	: Transmit / Receive	Temperature	: 25 °C
Operation Channel	: 11	Humidity	: 65 %
Modulation Type	: 802.11n, HT20	Atmospheric Pressure	: 1020 hPa
Memo	: MT12-Y120100-A1	Rate	: 130Mbps

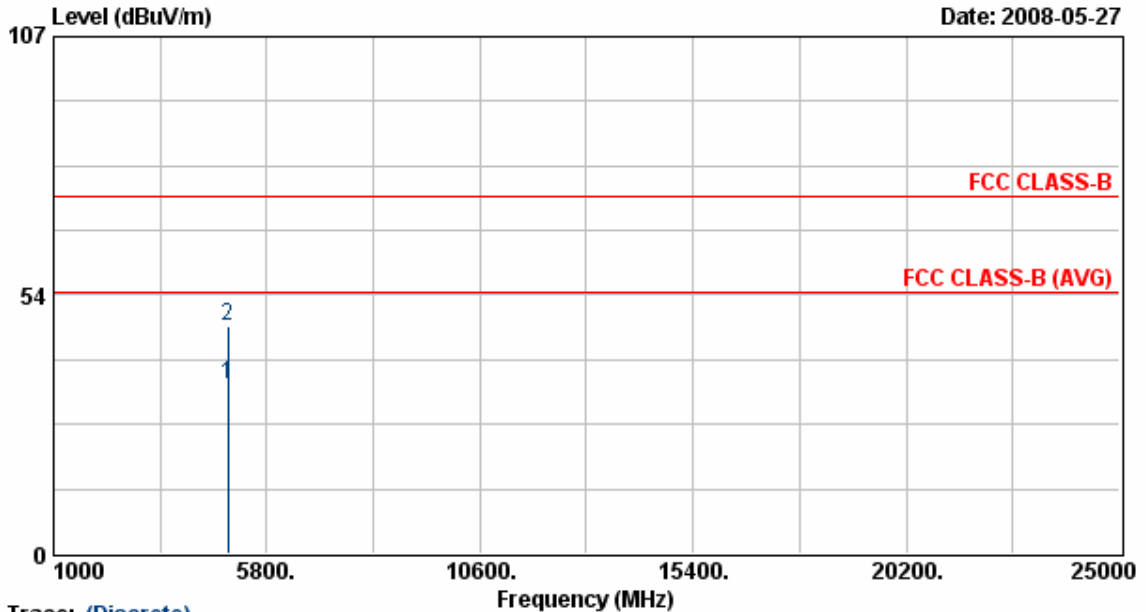

Trace: (Discrete)

Item	Freq	Read Value	Factor	Result	Limit	Margin	Remark	Ant Pos	Tab Pos
	MHz	dBuV/m	dB	dBuV/m	dBuV/m	dB		cm	Deg
1	4924.05	29.16	5.93	35.10	54.00	-18.90	Average	100	241
2	4924.05	41.03	5.93	46.97	74.00	-27.03	Peak	100	241

Notes:

1. Result = Read Value + Factor
2. Factor = Antenna Factor + Cable Loss - Amplifier
3. The resolution bandwidth of test receiver/spectrum analyzer is 120KHz and video bandwidth is 300kHz for Peak detection and Quasi-peak detection at frequency below 1GHz.
4. The resolution bandwidth of test receiver/spectrum analyzer is 1MHz and video bandwidth is 3MHz for Peak detection at frequency above 1GHz.
5. The resolution bandwidth of test receiver/spectrum analyzer is 1MHz and video bandwidth is 10Hz for Average detection at frequency above 1GHz.
6. The other emissions is too low to be measured.

Power	: AC 120V	Pol/Phase	: VERTICAL
Test Mode 3	: Transmit / Receive	Temperature	: 25 °C
Operation Channel	: 3	Humidity	: 65 %
Modulation Type	: 802.11n, HT40	Atmospheric Pressure	: 1020 hPa
Memo	: MT12-Y120100-A1	Rate	: 270Mbps

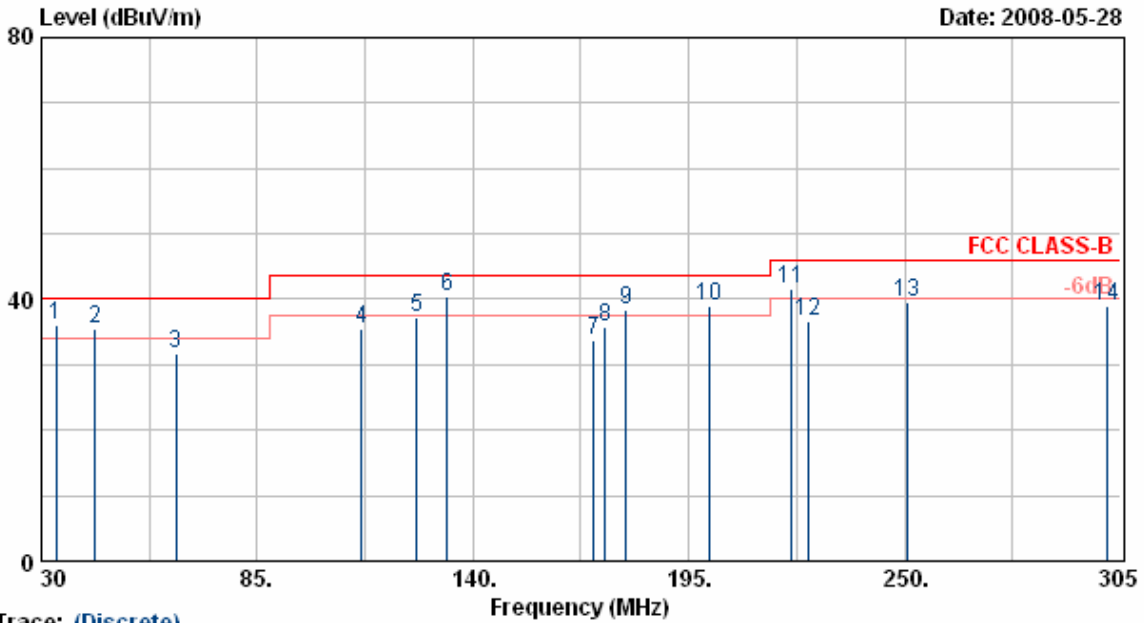

Trace: (Discrete)

Item	Freq	Read Value	Factor	Result	Limit	Margin	Remark	Ant Pos	Tab Pos
	MHz	dBuV/m	dB	dBuV/m	dBuV/m	dB		cm	Deg
1	33.65	43.46	-7.27	36.19	40.00	-3.81	QP	100	78
2	43.81	48.54	-13.13	35.41	40.00	-4.59	QP	100	210
3	64.29	50.70	-18.93	31.77	40.00	-8.23	Peak	100	210
4	111.60	48.57	-13.16	35.41	43.50	-8.09	Peak	100	179
5	125.58	50.79	-13.50	37.29	43.50	-6.21	Peak	100	179
6	133.34	55.66	-15.27	40.39	43.50	-3.11	QP	100	0
7	170.80	45.80	-11.96	33.84	43.50	-9.66	Peak	100	15
8	173.64	46.25	-10.47	35.78	43.50	-7.72	Peak	100	80
9	178.91	47.70	-9.41	38.29	43.50	-5.21	QP	100	111
10	200.02	50.65	-11.75	38.90	43.50	-4.60	QP	100	174
11	220.89	54.86	-13.34	41.52	46.00	-4.48	QP	100	69
12	225.48	48.80	-12.16	36.64	46.00	-9.36	Peak	100	69
13	250.59	52.20	-12.66	39.54	46.00	-6.46	Peak	100	69
14	301.40	48.00	-9.10	38.90	46.00	-7.10	Peak	100	78

Notes:

1. Result = Read Value + Factor
2. Factor = Antenna Factor + Cable Loss - Amplifier
3. The resolution bandwidth of test receiver/spectrum analyzer is 120KHz and video bandwidth is 300kHz for Peak detection and Quasi-peak detection at frequency below 1GHz.
4. According to technical experiences, all spurious emission of 802.11MIMO mode at channel 3,6,9 are almost the same below 1GHz, so that the channel 3 was chosen as representative in final test.
5. The data is worse case.

Power	: AC 120V	Pol/Phase	: VERTICAL
Test Mode 3	: Transmit / Receive	Temperature	: 25 °C
Operation Channel	: 3	Humidity	: 65 %
Modulation Type	: 802.11n, HT40	Atmospheric Pressure	: 1020 hPa
Memo	: MT12-Y120100-A1	Rate	: 270Mbps

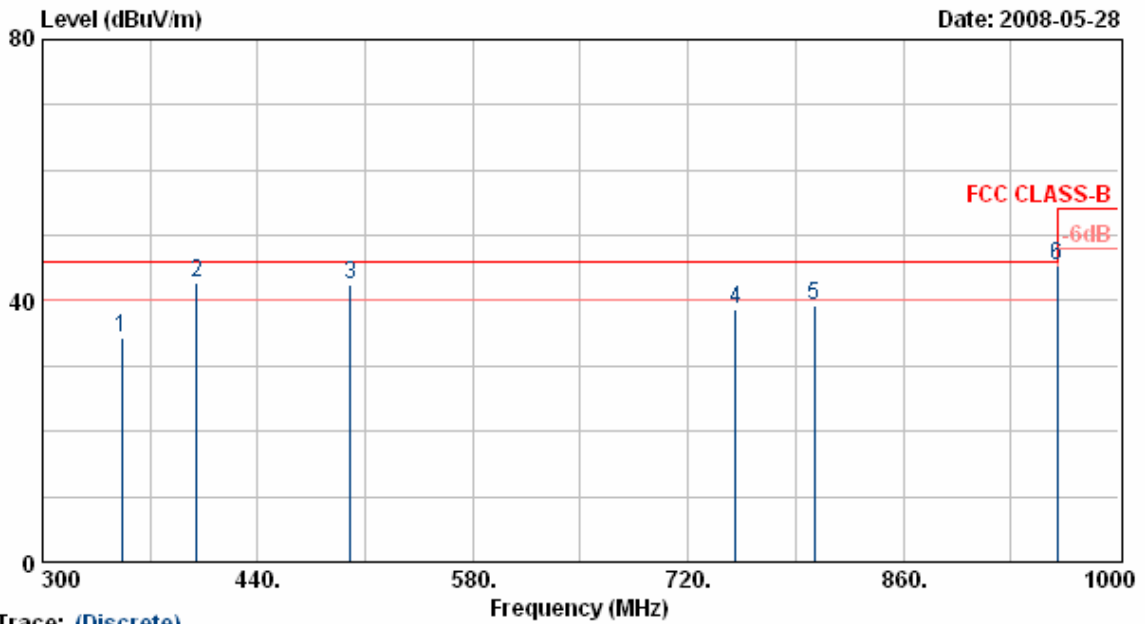

Trace: (Discrete)

Item	Freq	Read Value	Factor	Result	Limit	Margin	Remark	Ant Pos	Tab Pos
	MHz	dBuV/m	dB	dBuV/m	dBuV/m	dB		cm	Deg
1	351.80	44.93	-10.65	34.28	46.00	-11.72	Peak	100	44
2	400.03	51.66	-8.84	42.82	46.00	-3.18	QP	100	98
3	500.07	47.29	-4.86	42.43	46.00	-3.57	QP	100	162
4	750.80	37.58	1.04	38.62	46.00	-7.38	Peak	100	199
5	802.00	42.00	-2.78	39.22	46.00	-6.78	Peak	100	199
6	960.01	42.19	3.19	45.38	54.00	-8.62	Peak	100	0

Notes:

1. Result = Read Value + Factor
2. Factor = Antenna Factor + Cable Loss - Amplifier
3. The resolution bandwidth of test receiver/spectrum analyzer is 120KHz and video bandwidth is 300kHz for Peak detection and Quasi-peak detection at frequency below 1GHz.
4. According to technical experiences, all spurious emission of 802.11MIMO mode at channel 3,6,9 are almost the same below 1GHz, so that the channel 3 was chosen as representative in final test.
5. The data is worse case.

Power	: AC 120V	Pol/Phase	: HORIZONTAL
Test Mode 3	: Transmit / Receive	Temperature	: 25 °C
Operation Channel	: 3	Humidity	: 65 %
Modulation Type	: 802.11n, HT40	Atmospheric Pressure	: 1020 hPa
Memo	: MT12-Y120100-A1	Rate	: 270Mbps

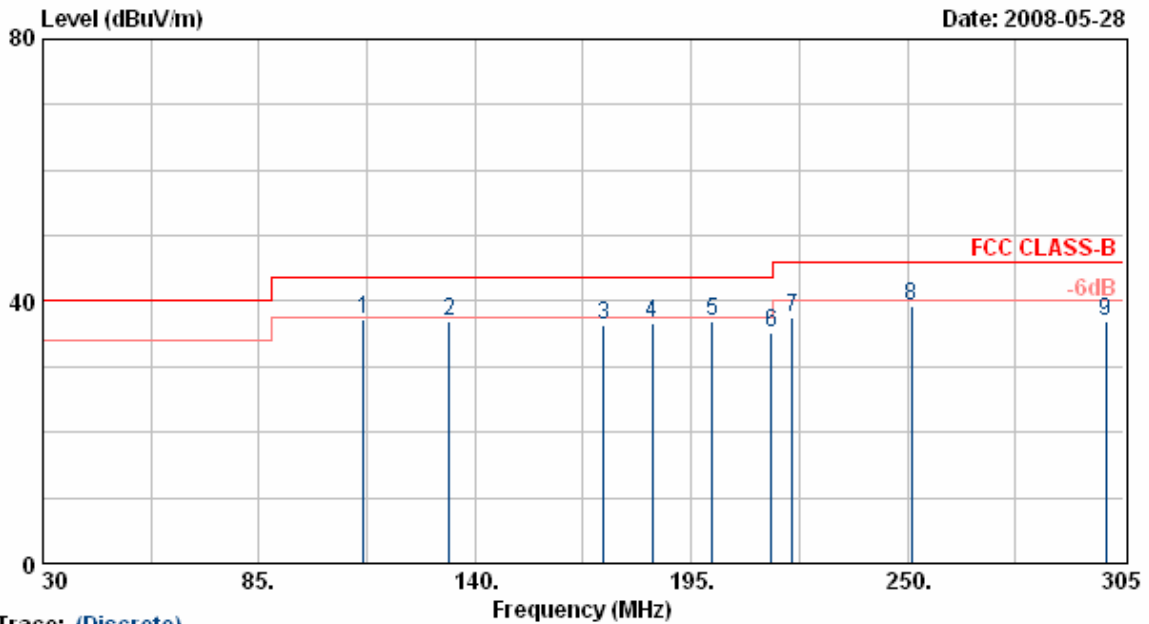

Trace: (Discrete)

Item	Freq	Read Value	Factor	Result	Limit	Margin	Remark	Ant Pos	Tab Pos
	MHz	dBuV/m	dB	dBuV/m	dBuV/m	dB		cm	Deg
1	111.68	56.60	-19.23	37.37	43.50	-6.13	Peak	200	48
2	133.33	56.33	-19.48	36.85	43.50	-6.65	Peak	200	48
3	172.73	54.16	-17.85	36.31	43.50	-7.19	Peak	200	142
4	185.10	54.42	-17.81	36.61	43.50	-6.89	Peak	200	139
5	200.25	51.43	-14.59	36.84	43.50	-6.66	Peak	200	139
6	215.35	53.71	-18.46	35.25	43.50	-8.25	Peak	200	0
7	220.85	55.59	-18.10	37.49	46.00	-8.51	Peak	200	20
8	251.10	56.65	-17.31	39.34	46.00	-6.66	Peak	200	20
9	300.60	51.41	-14.43	36.98	46.00	-9.02	Peak	200	20

Notes:

1. Result = Read Value + Factor
2. Factor = Antenna Factor + Cable Loss - Amplifier
3. The resolution bandwidth of test receiver/spectrum analyzer is 120KHz and video bandwidth is 300kHz for Peak detection and Quasi-peak detection at frequency below 1GHz.
4. According to technical experiences, all spurious emission of 802.11MIMO mode at channel 3,6,9 are almost the same below 1GHz, so that the channel 3 was chosen as representative in final test.
5. The data is worse case.

Power	: AC 120V	Pol/Phase	: HORIZONTAL
Test Mode 3	: Transmit / Receive	Temperature	: 25 °C
Operation Channel	: 3	Humidity	: 65 %
Modulation Type	: 802.11n, HT40	Atmospheric Pressure	: 1020 hPa
Memo	: MT12-Y120100-A1	Rate	: 270Mbps

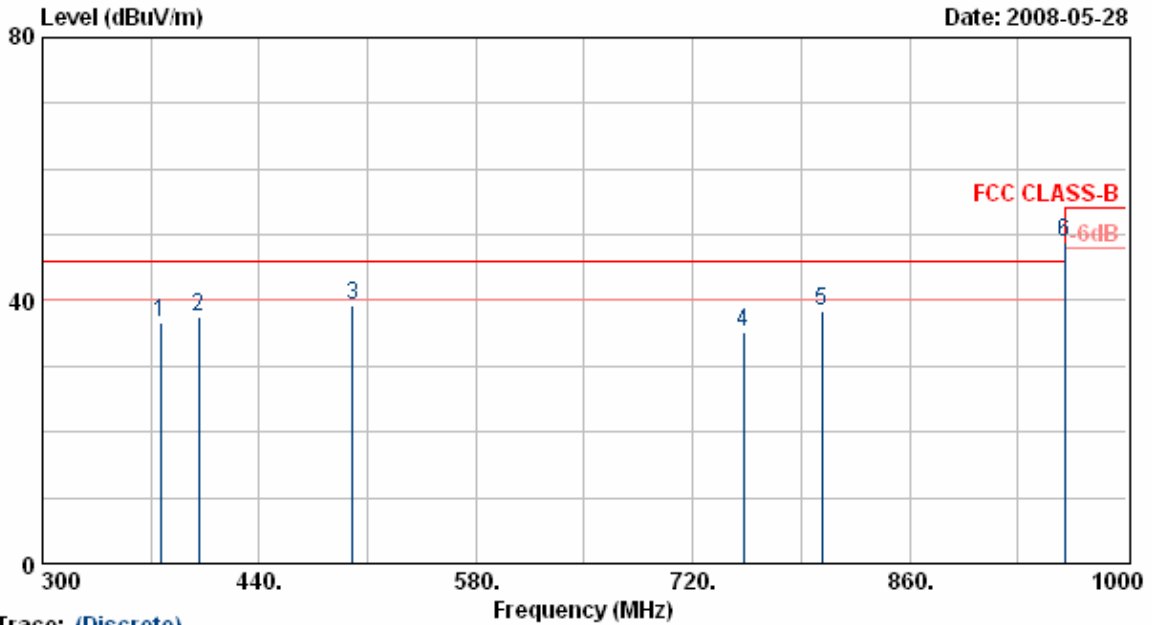

Trace: (Discrete)

Item	Freq	Read Value	Factor	Result	Limit	Margin	Remark	Ant Pos	Tab Pos
	MHz	dBuV/m	dB	dBuV/m	dBuV/m	dB		cm	Deg
1	376.30	47.66	-10.87	36.79	46.00	-9.21	Peak	200	79
2	400.80	48.53	-11.10	37.43	46.00	-8.57	Peak	200	198
3	500.20	43.50	-4.27	39.23	46.00	-6.77	Peak	200	251
4	752.90	35.33	-0.03	35.30	46.00	-10.70	Peak	200	211
5	803.30	38.66	-0.29	38.37	46.00	-7.63	Peak	200	251
6	960.05	42.49	6.33	48.82	54.00	-5.18	QP	200	0

Notes:

1. Result = Read Value + Factor
2. Factor = Antenna Factor + Cable Loss - Amplifier
3. The resolution bandwidth of test receiver/spectrum analyzer is 120KHz and video bandwidth is 300kHz for Peak detection and Quasi-peak detection at frequency below 1GHz.
4. According to technical experiences, all spurious emission of 802.11MIMO mode at channel 3,6,9 are almost the same below 1GHz, so that the channel 3 was chosen as representative in final test.
5. The data is worse case.

Power	: AC 120V	Pol/Phase	: VERTICAL
Test Mode 3	: Transmit / Receive	Temperature	: 25 °C
Operation Channel	: 3	Humidity	: 65 %
Modulation Type	: 802.11n, HT40	Atmospheric Pressure	: 1020 hPa
Memo	: MT12-Y120100-A1	Rate	: 270Mbps

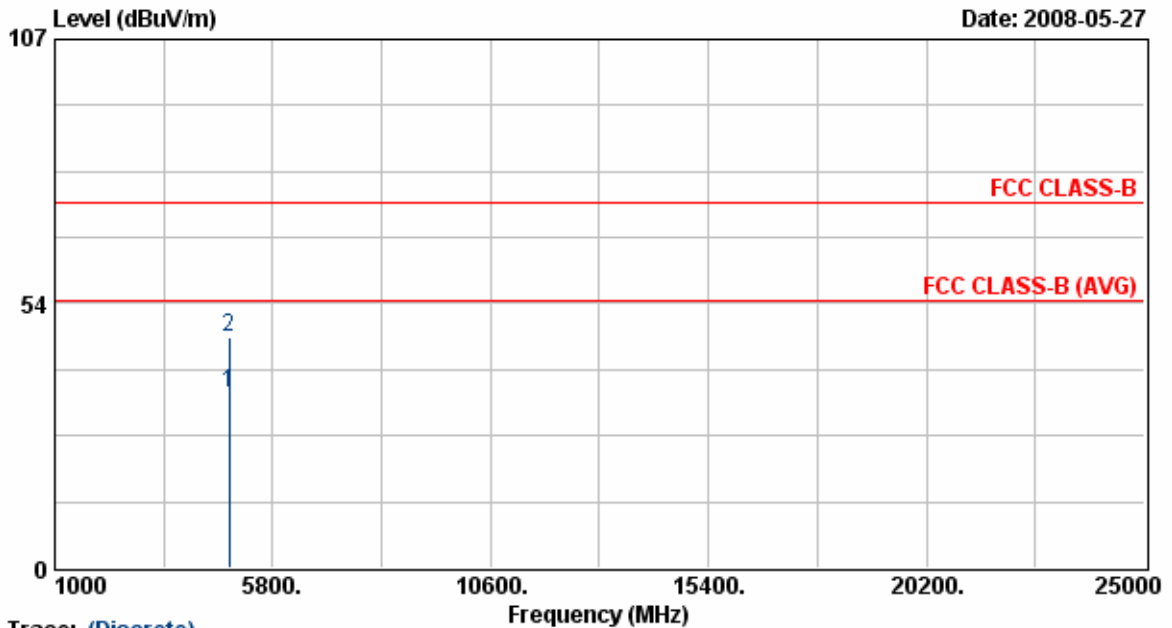

Trace: (Discrete)

Item	Freq	Read Value	Factor	Result	Limit	Margin	Remark	Ant Pos	Tab Pos
	MHz	dBuV/m	dB	dBuV/m	dBuV/m	dB		cm	Deg
1	4844.23	29.50	5.72	35.22	54.00	-18.78	Average	100	144
2	4844.23	41.14	5.72	46.86	74.00	-27.14	Peak	100	144

Notes:

1. Result = Read Value + Factor
2. Factor = Antenna Factor + Cable Loss - Amplifier
3. The resolution bandwidth of test receiver/spectrum analyzer is 120KHz and video bandwidth is 300kHz for Peak detection and Quasi-peak detection at frequency below 1GHz.
4. The resolution bandwidth of test receiver/spectrum analyzer is 1MHz and video bandwidth is 3MHz for Peak detection at frequency above 1GHz.
5. The resolution bandwidth of test receiver/spectrum analyzer is 1MHz and video bandwidth is 10Hz for Average detection at frequency above 1GHz.
6. The other emissions is too low to be measured.

Power	: AC 120V	Pol/Phase	: HORIZONTAL
Test Mode 3	: Transmit / Receive	Temperature	: 25 °C
Operation Channel	: 3	Humidity	: 65 %
Modulation Type	: 802.11n, HT40	Atmospheric Pressure	: 1020 hPa
Memo	: MT12-Y120100-A1	Rate	: 270Mbps

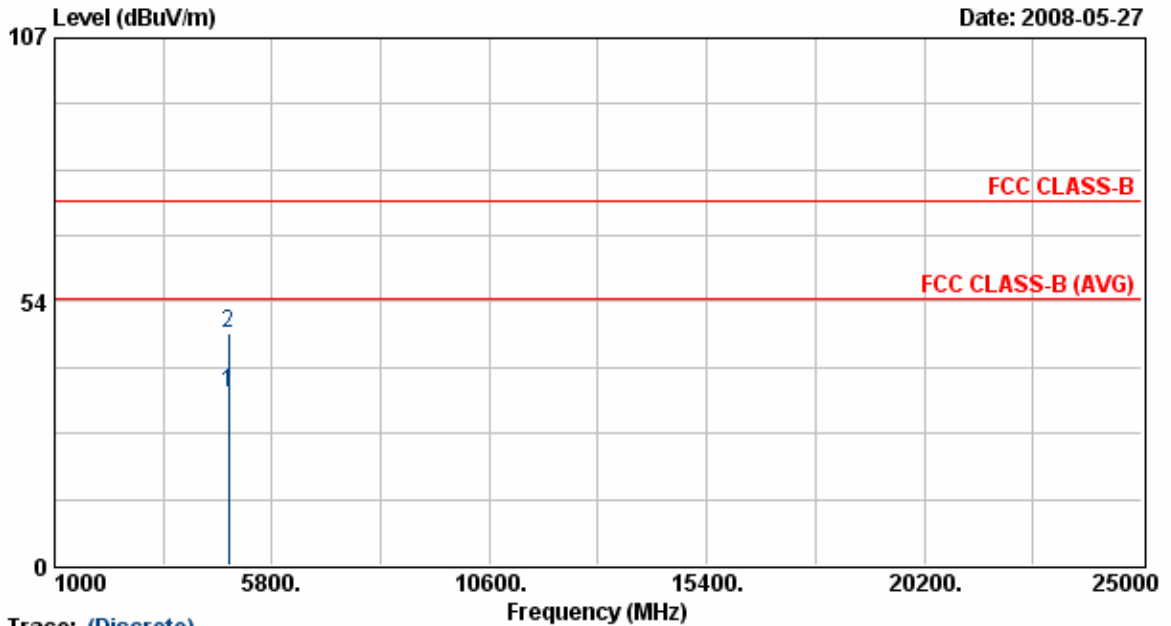

Trace: (Discrete)

Item	Freq	Read Value	Factor	Result	Limit	Margin	Remark	Ant Pos	Tab Pos
	MHz	dBuV/m	dB	dBuV/m	dBuV/m	dB		cm	Deg
1	4843.83	29.47	5.72	35.19	54.00	-18.81	Average	100	241
2	4843.83	41.17	5.72	46.89	74.00	-27.11	Peak	100	241

Notes:

1. Result = Read Value + Factor
2. Factor = Antenna Factor + Cable Loss - Amplifier
3. The resolution bandwidth of test receiver/spectrum analyzer is 120KHz and video bandwidth is 300kHz for Peak detection and Quasi-peak detection at frequency below 1GHz.
4. The resolution bandwidth of test receiver/spectrum analyzer is 1MHz and video bandwidth is 3MHz for Peak detection at frequency above 1GHz.
5. The resolution bandwidth of test receiver/spectrum analyzer is 1MHz and video bandwidth is 10Hz for Average detection at frequency above 1GHz.
6. The other emissions is too low to be measured.

Power	: AC 120V	Pol/Phase	: VERTICAL
Test Mode 3	: Transmit / Receive	Temperature	: 25 °C
Operation Channel	: 6	Humidity	: 65 %
Modulation Type	: 802.11n, HT40	Atmospheric Pressure	: 1020 hPa
Memo	: MT12-Y120100-A1	Rate	: 270Mbps

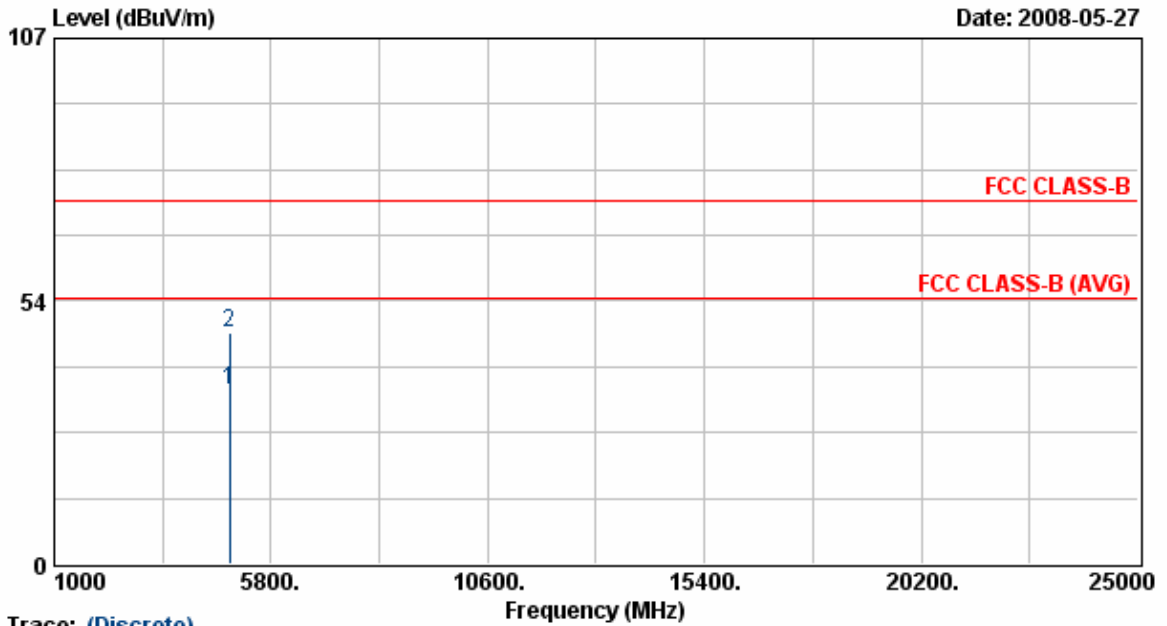

Trace: (Discrete)

Item	Freq	Read Value	Factor	Result	Limit	Margin	Remark	Ant Pos	Tab Pos
	MHz	dBuV/m	dB	dBuV/m	dBuV/m	dB		cm	Deg
1	4874.03	29.59	5.80	35.39	54.00	-18.61	Average	100	144
2	4874.03	41.13	5.80	46.94	74.00	-27.06	Peak	100	144

Notes:

1. Result = Read Value + Factor
2. Factor = Antenna Factor + Cable Loss - Amplifier
3. The resolution bandwidth of test receiver/spectrum analyzer is 120KHz and video bandwidth is 300kHz for Peak detection and Quasi-peak detection at frequency below 1GHz.
4. The resolution bandwidth of test receiver/spectrum analyzer is 1MHz and video bandwidth is 3MHz for Peak detection at frequency above 1GHz.
5. The resolution bandwidth of test receiver/spectrum analyzer is 1MHz and video bandwidth is 10Hz for Average detection at frequency above 1GHz.
6. The other emissions is too low to be measured.

Power	: AC 120V	Pol/Phase	: HORIZONTAL
Test Mode 3	: Transmit / Receive	Temperature	: 25 °C
Operation Channel	: 6	Humidity	: 65 %
Modulation Type	: 802.11n, HT40	Atmospheric Pressure	: 1020 hPa
Memo	: MT12-Y120100-A1	Rate	: 270Mbps

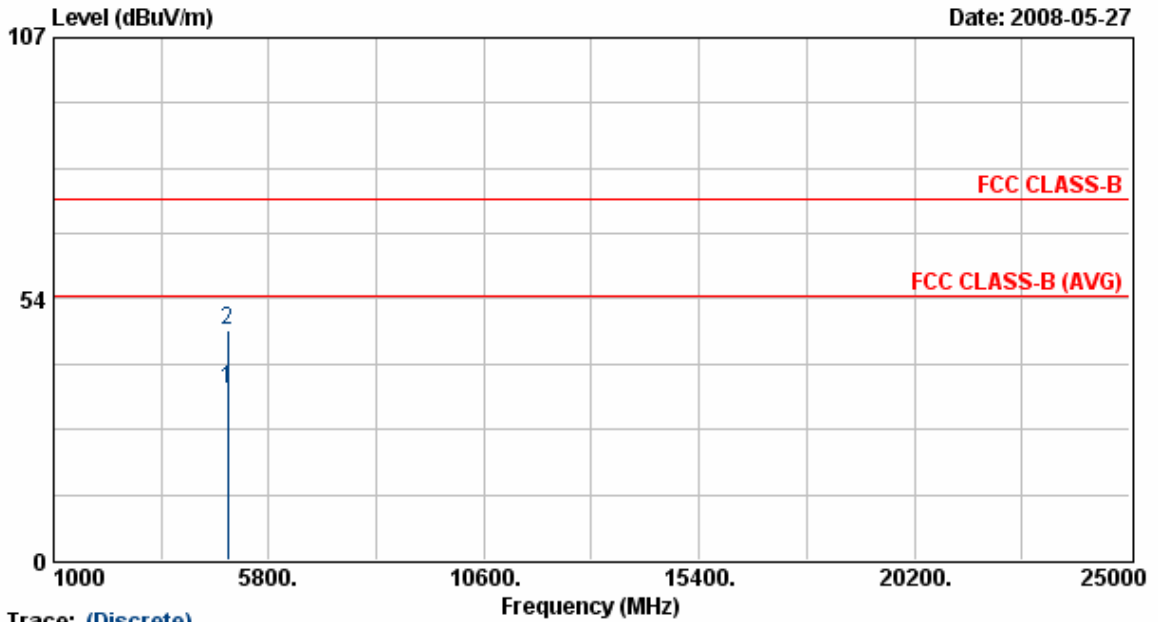

Trace: (Discrete)

Item	Freq	Read Value	Factor	Result	Limit	Margin	Remark	Ant Pos	Tab Pos
	MHz	dBuV/m	dB	dBuV/m	dBuV/m	dB		cm	Deg
1	4874.08	29.38	5.80	35.18	54.00	-18.82	Average	100	241
2	4874.08	41.17	5.80	46.97	74.00	-27.03	Peak	100	241

Notes:

1. Result = Read Value + Factor
2. Factor = Antenna Factor + Cable Loss - Amplifier
3. The resolution bandwidth of test receiver/spectrum analyzer is 120KHz and video bandwidth is 300kHz for Peak detection and Quasi-peak detection at frequency below 1GHz.
4. The resolution bandwidth of test receiver/spectrum analyzer is 1MHz and video bandwidth is 3MHz for Peak detection at frequency above 1GHz.
5. The resolution bandwidth of test receiver/spectrum analyzer is 1MHz and video bandwidth is 10Hz for Average detection at frequency above 1GHz.
6. The other emissions is too low to be measured.

Power	: AC 120V	Pol/Phase	: VERTICAL
Test Mode 3	: Transmit / Receive	Temperature	: 25 °C
Operation Channel	: 9	Humidity	: 65 %
Modulation Type	: 802.11n, HT40	Atmospheric Pressure	: 1020 hPa
Memo	: MT12-Y120100-A1	Rate	: 270Mbps

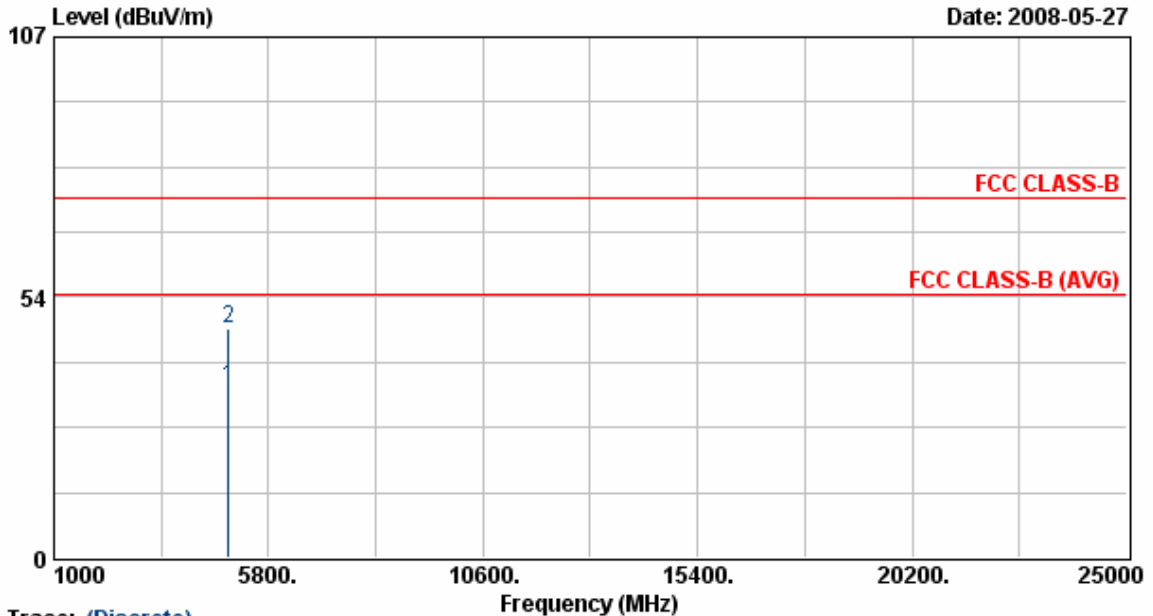

Trace: (Discrete)

Item	Freq	Read Value	Factor	Result	Limit	Margin	Remark	Ant Pos	Tab Pos
	MHz	dBuV/m	dB	dBuV/m	dBuV/m	dB		cm	Deg
1	4903.90	29.31	5.88	35.19	54.00	-18.81	Average	100	144
2	4903.90	41.29	5.88	47.17	74.00	-26.83	Peak	100	144

Notes:

1. Result = Read Value + Factor
2. Factor = Antenna Factor + Cable Loss - Amplifier
3. The resolution bandwidth of test receiver/spectrum analyzer is 120KHz and video bandwidth is 300kHz for Peak detection and Quasi-peak detection at frequency below 1GHz.
4. The resolution bandwidth of test receiver/spectrum analyzer is 1MHz and video bandwidth is 3MHz for Peak detection at frequency above 1GHz.
5. The resolution bandwidth of test receiver/spectrum analyzer is 1MHz and video bandwidth is 10Hz for Average detection at frequency above 1GHz.
6. The other emissions is too low to be measured.

Power	: AC 120V	Pol/Phase	: HORIZONTAL
Test Mode 3	: Transmit / Receive	Temperature	: 25 °C
Operation Channel	: 9	Humidity	: 65 %
Modulation Type	: 802.11n, HT40	Atmospheric Pressure	: 1020 hPa
Memo	: MT12-Y120100-A1	Rate	: 270Mbps

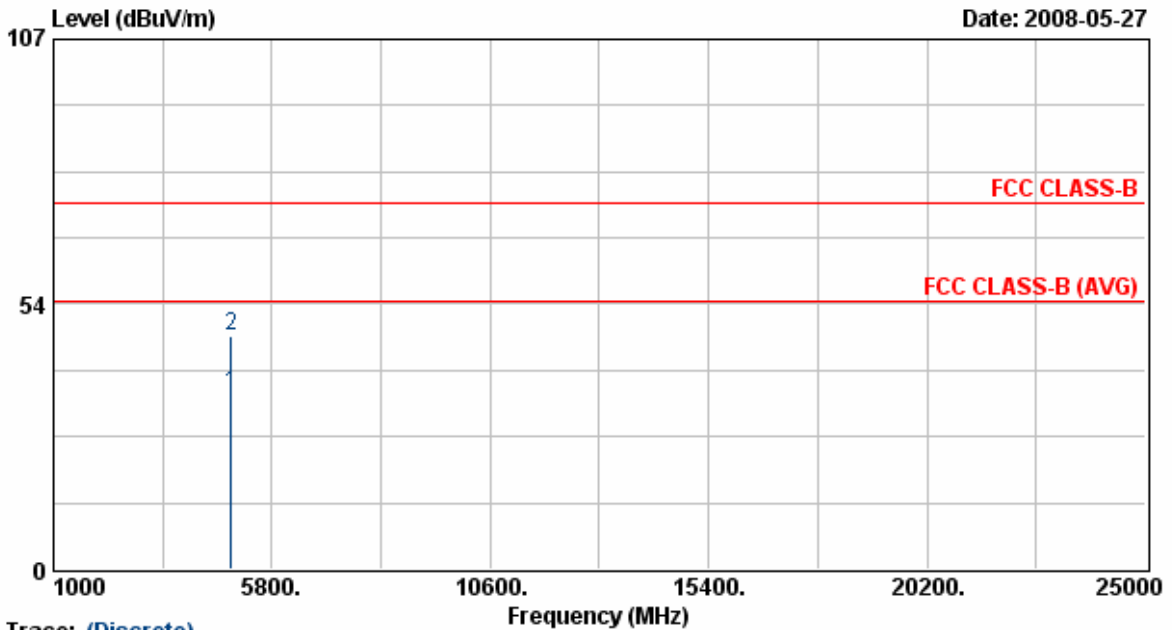

Trace: (Discrete)

Item	Freq	Read Value	Factor	Result	Limit	Margin	Remark	Ant Pos	Tab Pos
	MHz	dBuV/m	dB	dBuV/m	dBuV/m	dB		cm	Deg
1	4904.15	29.41	5.88	35.29	54.00	-18.71	Average	100	241
2	4904.15	41.23	5.88	47.11	74.00	-26.89	Peak	100	241

Notes:

1. Result = Read Value + Factor
2. Factor = Antenna Factor + Cable Loss - Amplifier
3. The resolution bandwidth of test receiver/spectrum analyzer is 120KHz and video bandwidth is 300kHz for Peak detection and Quasi-peak detection at frequency below 1GHz.
4. The resolution bandwidth of test receiver/spectrum analyzer is 1MHz and video bandwidth is 3MHz for Peak detection at frequency above 1GHz.
5. The resolution bandwidth of test receiver/spectrum analyzer is 1MHz and video bandwidth is 10Hz for Average detection at frequency above 1GHz.
6. The other emissions is too low to be measured.

Test engineer: Ben

6. 6dB Bandwidth Measurement Data

6.1 Test Limit

The minimum of 6dB Bandwidth Measurement is 0.5 MHz.

6.2 Test Procedures

- The transmitter output was connected to the spectrum analyzer.
- Set RBW of spectrum analyzer to 100 KHz and VBW to 100 KHz.
- The 6 dB bandwidth is defined as the total spectrum the power of which is higher than peak power minus 6 dB.

6.3 Test Setup Layout

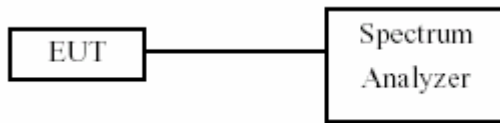

6.4 Measurement equipment

Instrument/Ancillary	Model No.	Manufacturer	Serial No.	Calibration Date	Valid Date
Spectrum Analyzer	FSP40	R&S	10047	2008/02/22	2009/02/21

6.5 Test Result and Data

- (1) Modulation Standard: IEEE 802.11b (11Mbps), ANT-L
 Test Date: May. 26, 2008 Temperature: 20 Humidity: 60% Atmospheric pressure: 1008 hPa

Channel	Frequency (MHz)	6dB Bandwidth (MHz)
01	2412	11.20
06	2437	11.10
11	2462	10.60

- (2) Modulation Standard: IEEE 802.11g (54Mbps), ANT-L
 Test Date: May. 26, 2008 Temperature: 20 Humidity: 60% Atmospheric pressure: 1008 hPa

Channel	Frequency (MHz)	6dB Bandwidth (MHz)
01	2412	16.40
06	2437	16.40
11	2462	16.40

- (3) Modulation Standard: IEEE 802.11b (11Mbps), ANT-R
 Test Date: May. 26, 2008 Temperature: 20 Humidity: 60% Atmospheric pressure: 1008 hPa

Channel	Frequency (MHz)	6dB Bandwidth (MHz)
01	2412	11.40
06	2437	11.10
11	2462	10.60

- (4) Modulation Standard: IEEE 802.11g (54Mbps), ANT-R
 Test Date: May. 26, 2008 Temperature: 20 Humidity: 60% Atmospheric pressure: 1008 hPa

Channel	Frequency (MHz)	6dB Bandwidth (MHz)
01	2412	16.40
06	2437	16.60
11	2462	16.50

(5) Modulation Standard: IEEE 802.11n, HT20 (130Mbps)

Test Date: May. 26, 2008 Temperature: 20 Humidity: 60% Atmospheric pressure: 1008 hPa

Channel	Frequency (MHz)	6dB Bandwidth (MHz)	
		ANT-L	ANT-R
01	2412	17.70	17.70
06	2437	17.60	17.70
11	2462	17.70	17.80

(6) Modulation Standard: IEEE 802.11, HT40 (270Mbps)

Test Date: May. 26, 2008 Temperature: 20 Humidity: 60% Atmospheric pressure: 1008 hPa

Channel	Frequency (MHz)	6dB Bandwidth (MHz)	
		ANT-L	ANT-R
03	2422	35.80	36.20
06	2437	35.20	35.00
09	2452	36.40	36.20

Modulation Standard: 802.11b (11Mbps), ANT-L
 Channel: 01

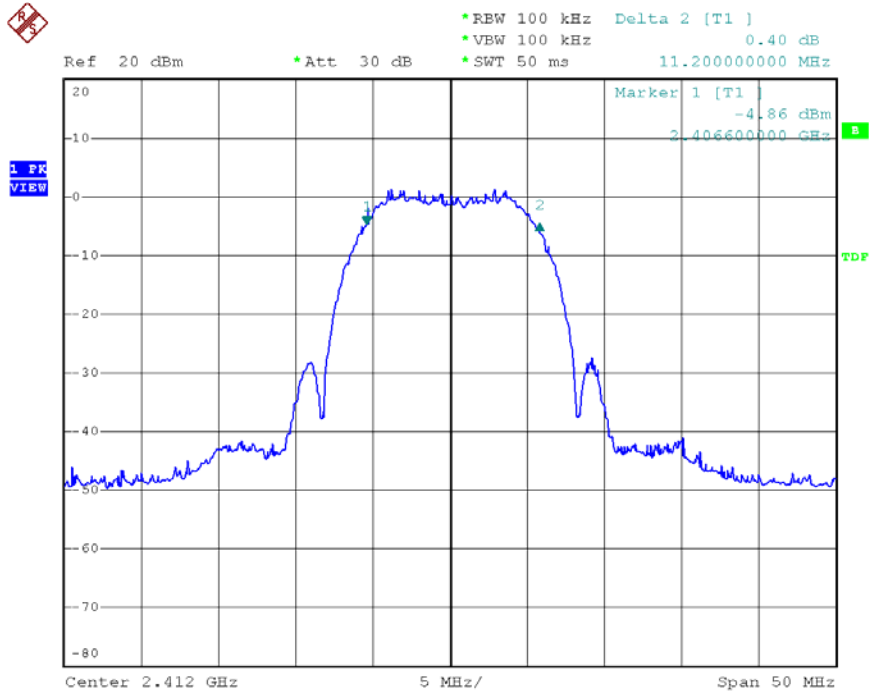

Date: 26.MAY.2008 10:57:34

Modulation Standard: 802.11b (11Mbps), ANT-L
 Channel: 06

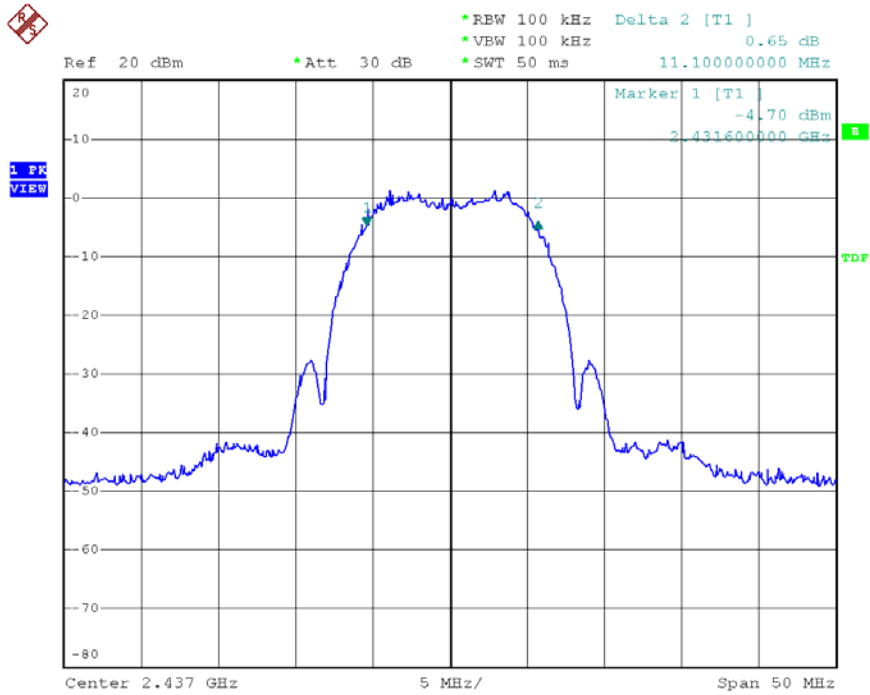

Date: 26.MAY.2008 10:59:52

Modulation Standard: 802.11b (11Mbps), ANT-L
 Channel: 11

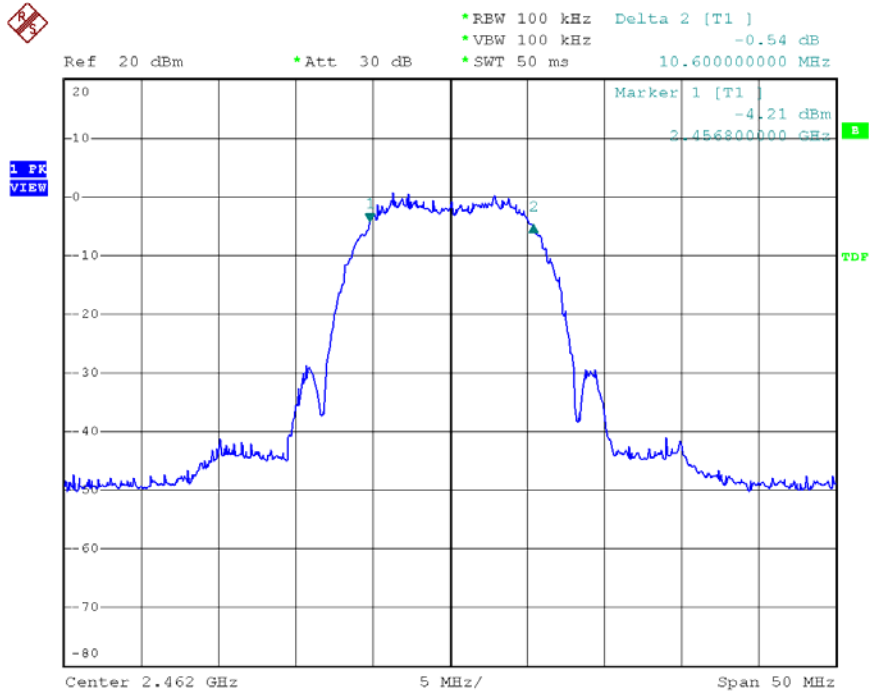

Date: 26.MAY.2008 11:01:31

Modulation Standard: 802.11g (54Mbps), ANT-L
 Channel: 01

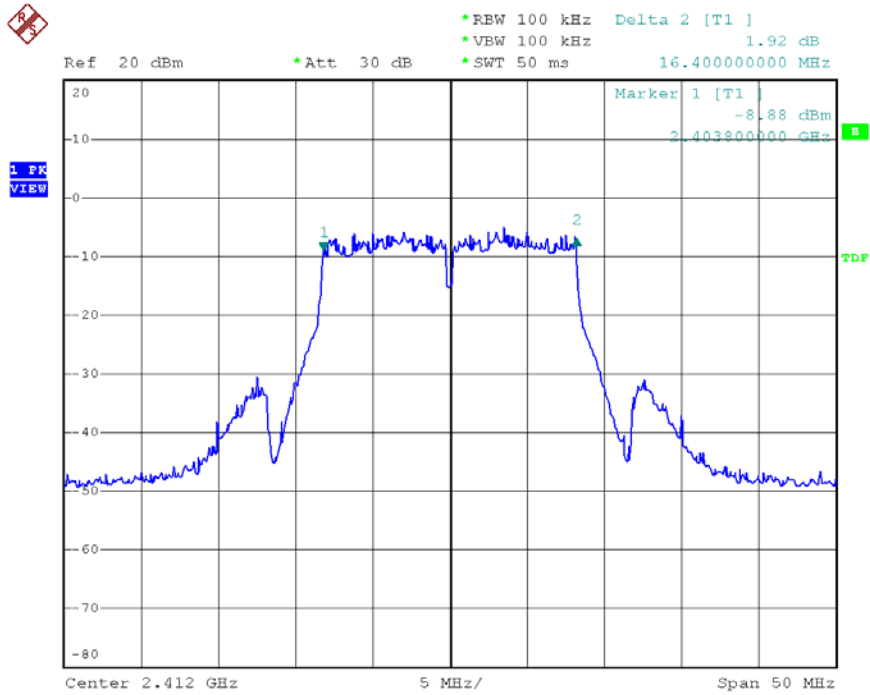

Date: 26.MAY.2008 10:50:57

Modulation Standard: 802.11g (54Mbps), ANT-L
 Channel: 06

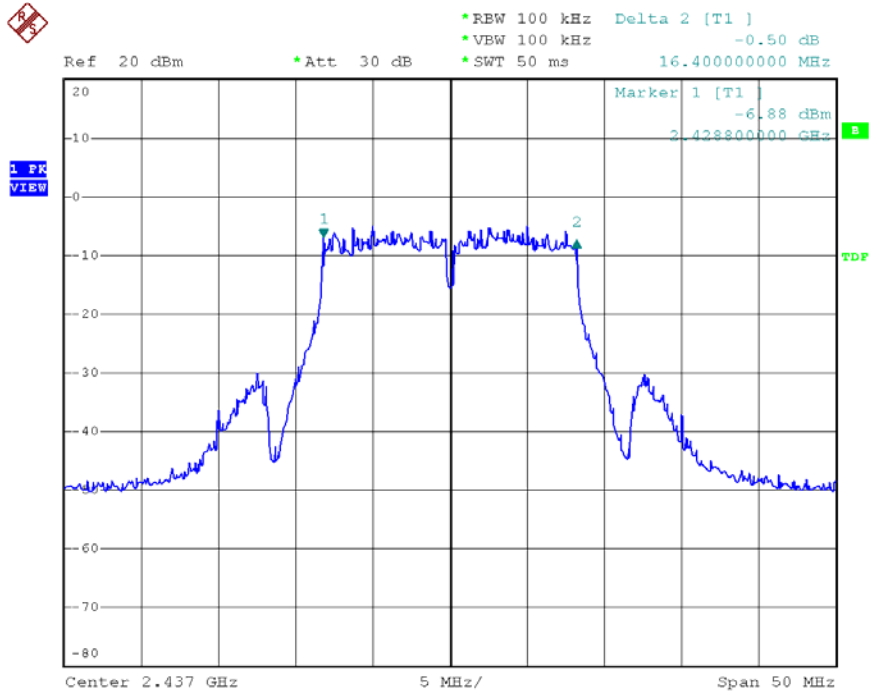

Date: 26.MAY.2008 10:55:11

Modulation Standard: 802.11g (54Mbps), ANT-L
 Channel: 11

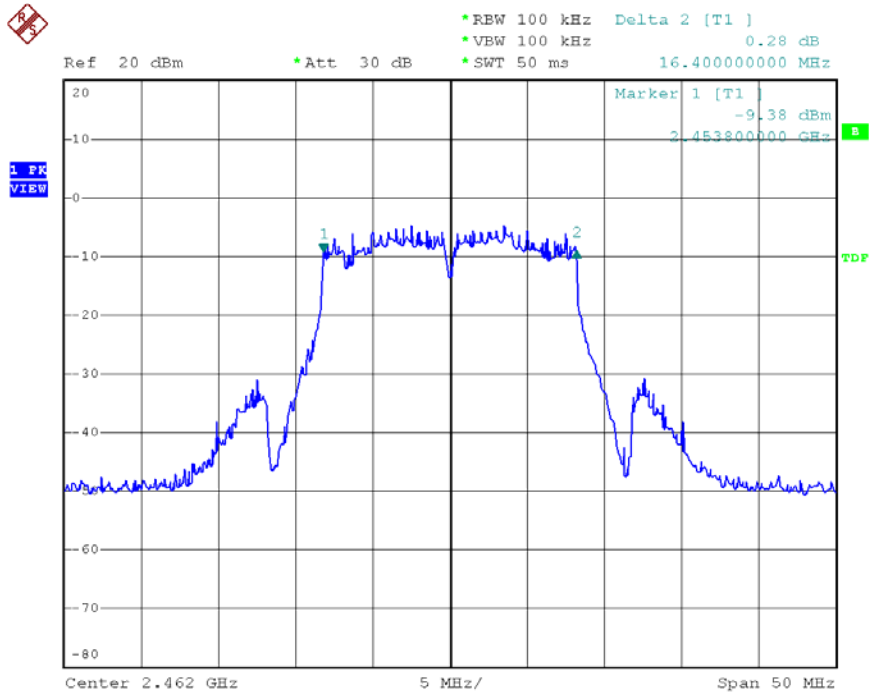

Date: 26.MAY.2008 10:48:04

Modulation Standard: 802.11b (11Mbps), ANT-R
 Channel: 01

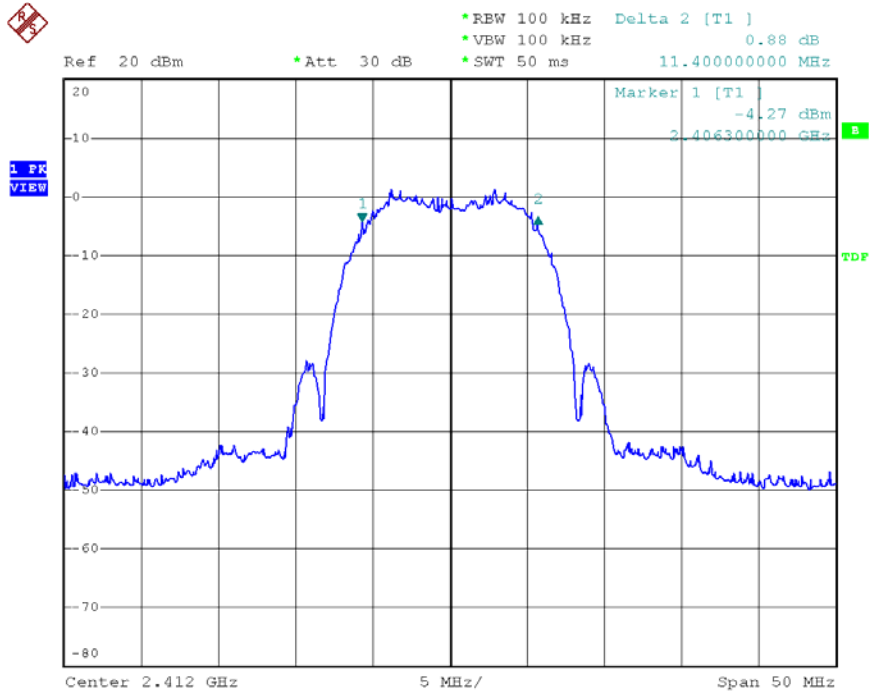

Date: 26.MAY.2008 14:24:24

Modulation Standard: 802.11b (11Mbps), ANT-R
 Channel: 06

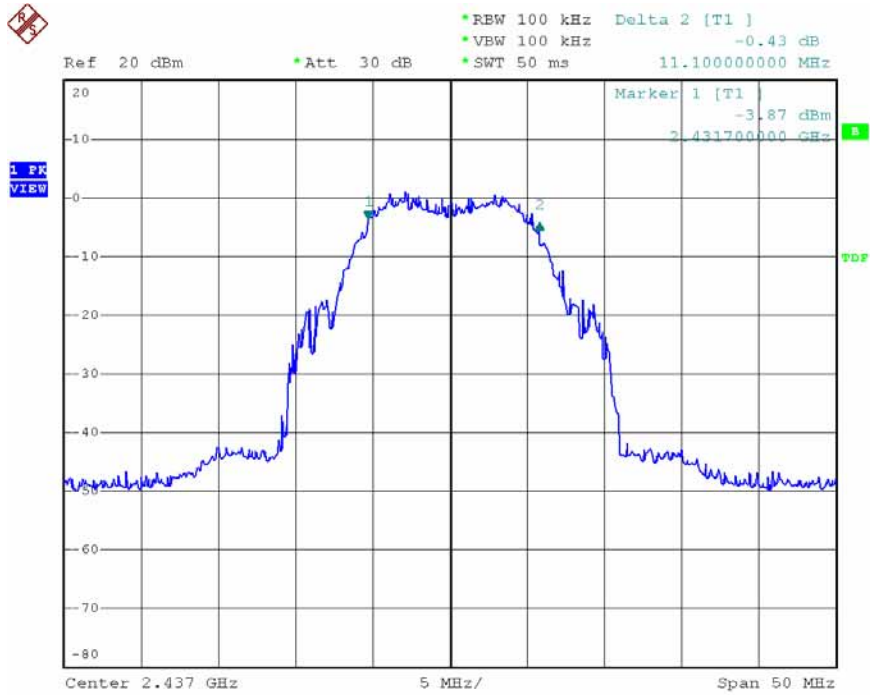

Date: 26.MAY.2008 14:26:40

Modulation Standard: 802.11b (11Mbps), ANT-R
 Channel: 11

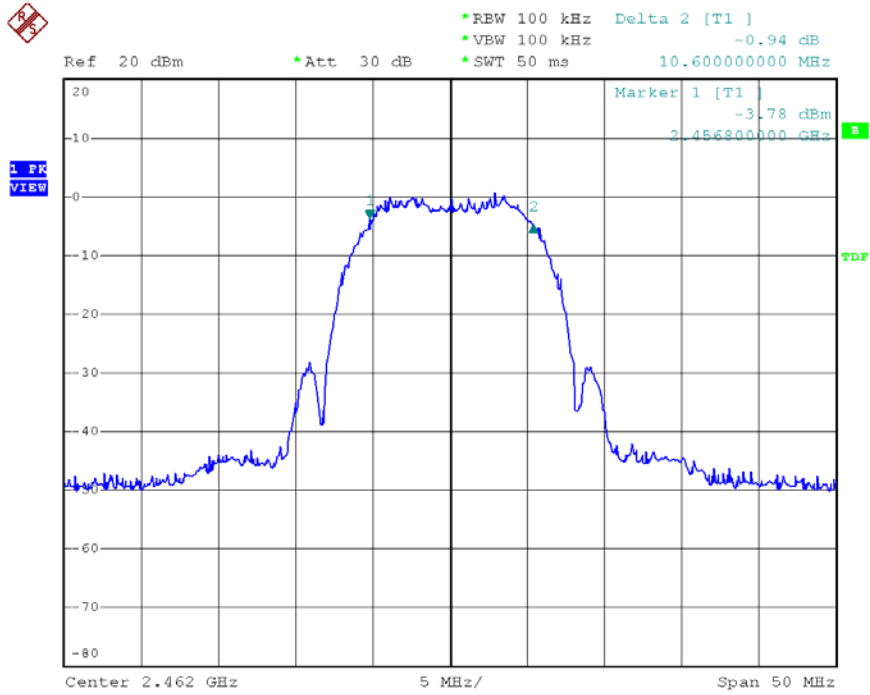

Date: 26.MAY.2008 14:28:05

Modulation Standard: 802.11g (54Mbps), ANT-R
 Channel: 01

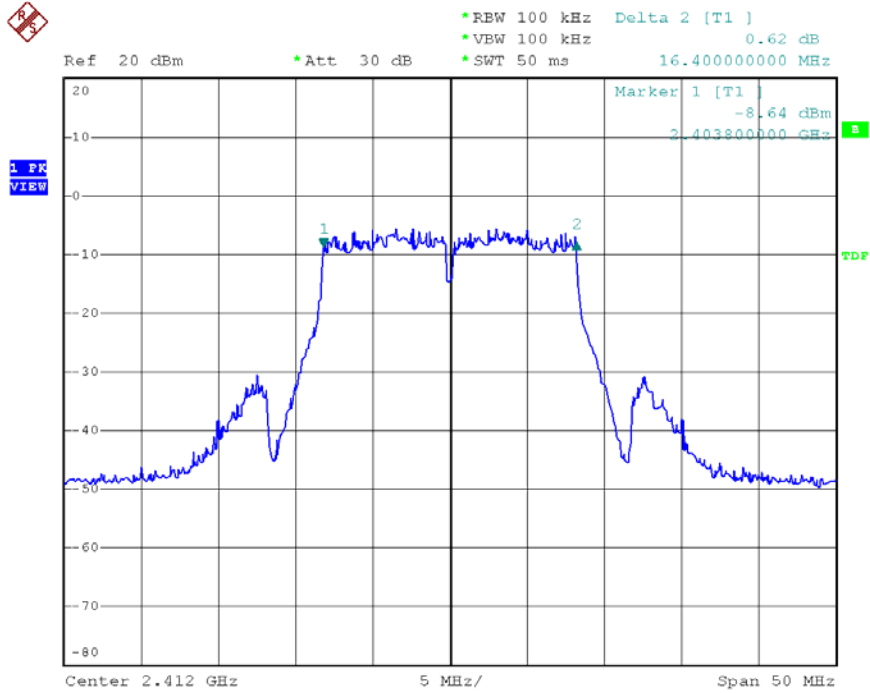

Date: 26.MAY.2008 14:30:00

Modulation Standard: 802.11g (54Mbps), ANT-R
 Channel: 06

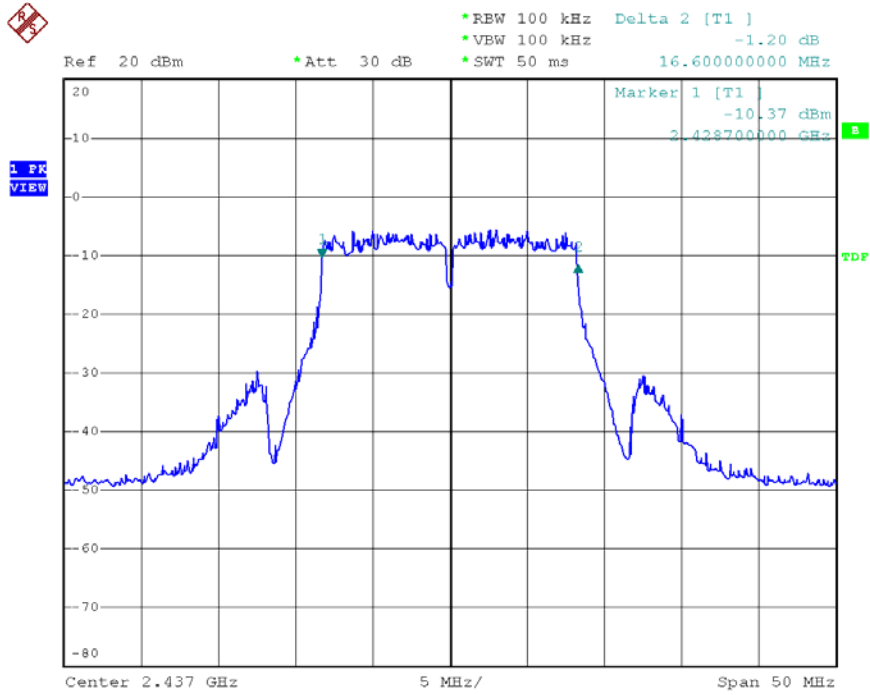

Date: 26.MAY.2008 14:32:00

Modulation Standard: 802.11g (54Mbps), ANT-R
 Channel: 11

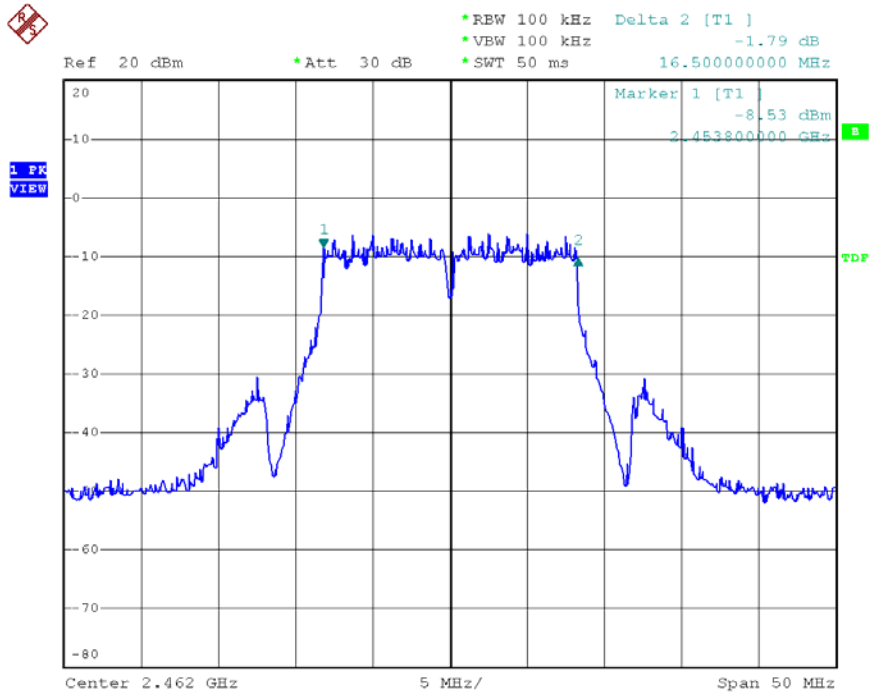

Date: 26.MAY.2008 14:35:55

Modulation Standard: 802.11n, HT20 (130Mbps) , ANT-L
 Channel: 01

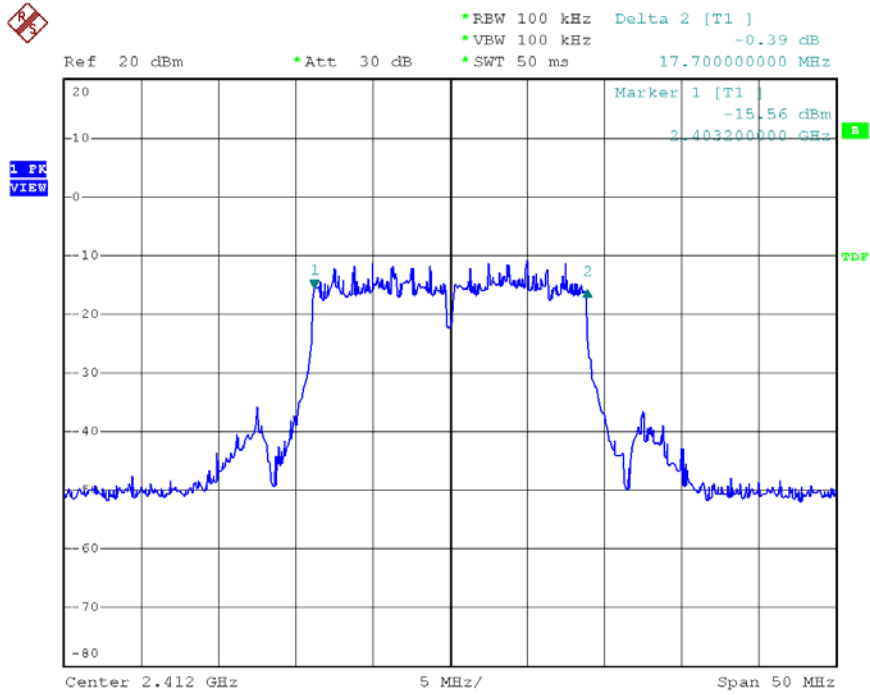

Date: 26.MAY.2008 15:22:07

Modulation Standard: 802.11n, HT20 (130Mbps) , ANT-L
 Channel: 06

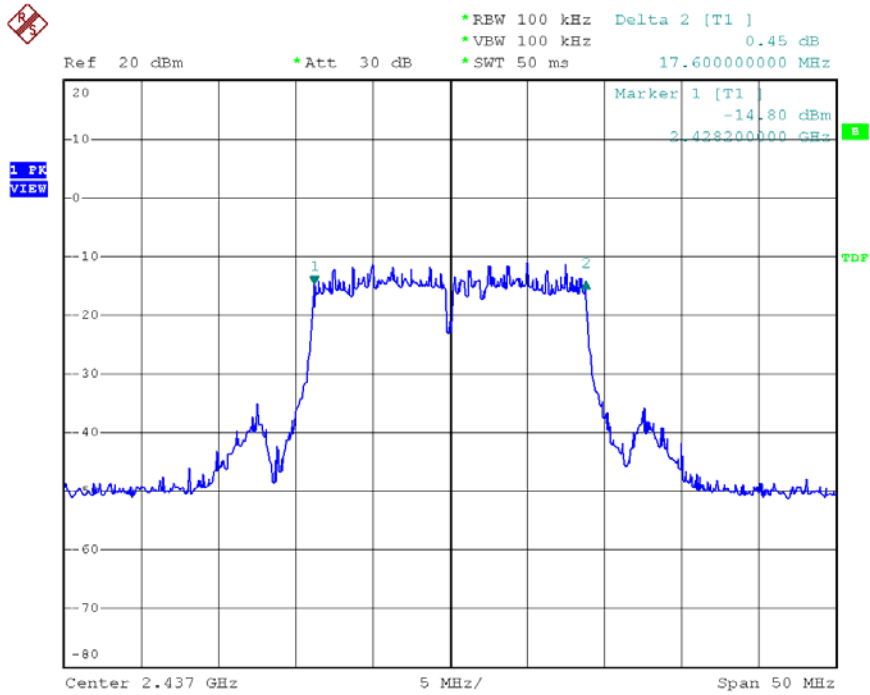

Date: 26.MAY.2008 15:18:37

Modulation Standard: 802.11n, HT20 (130Mbps) , ANT-L
 Channel: 11

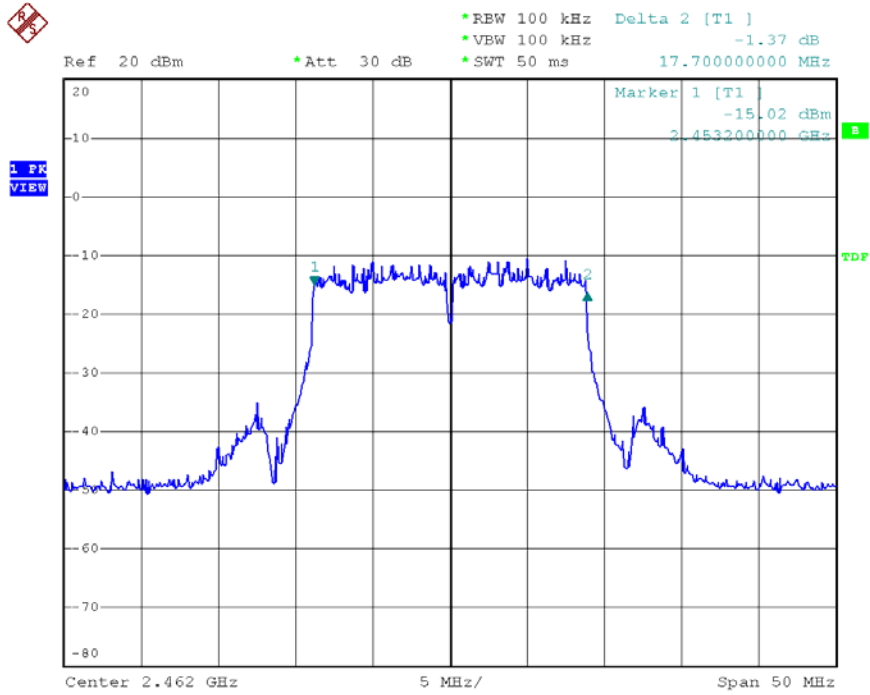

Date: 26.MAY.2008 15:15:57

Modulation Standard: 802.11n, HT20 (130Mbps) , ANT-R
 Channel: 01

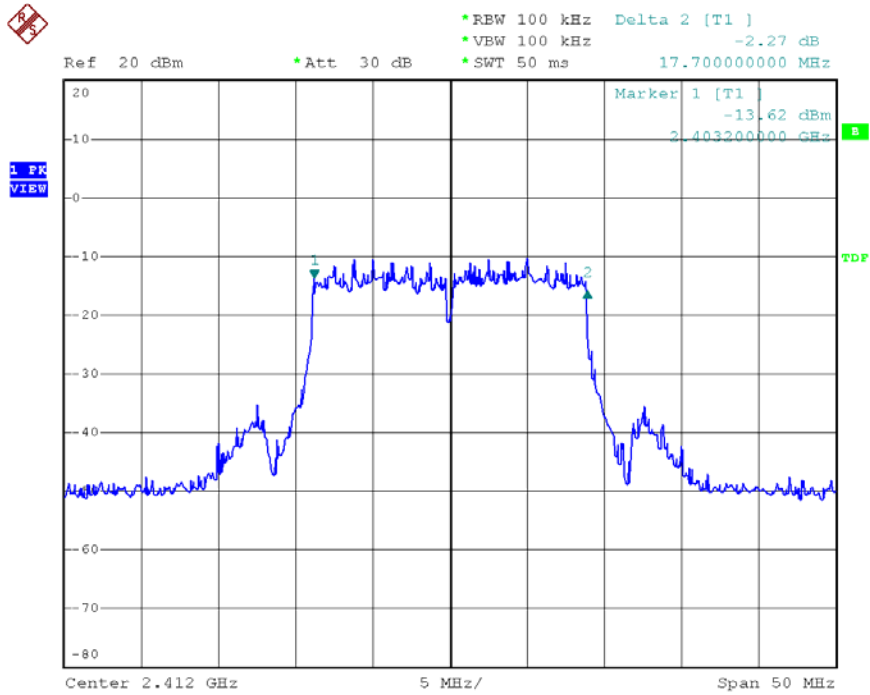

Date: 26.MAY.2008 15:26:39

Modulation Standard: 802.11n, HT20 (130Mbps) , ANT-R
 Channel: 06

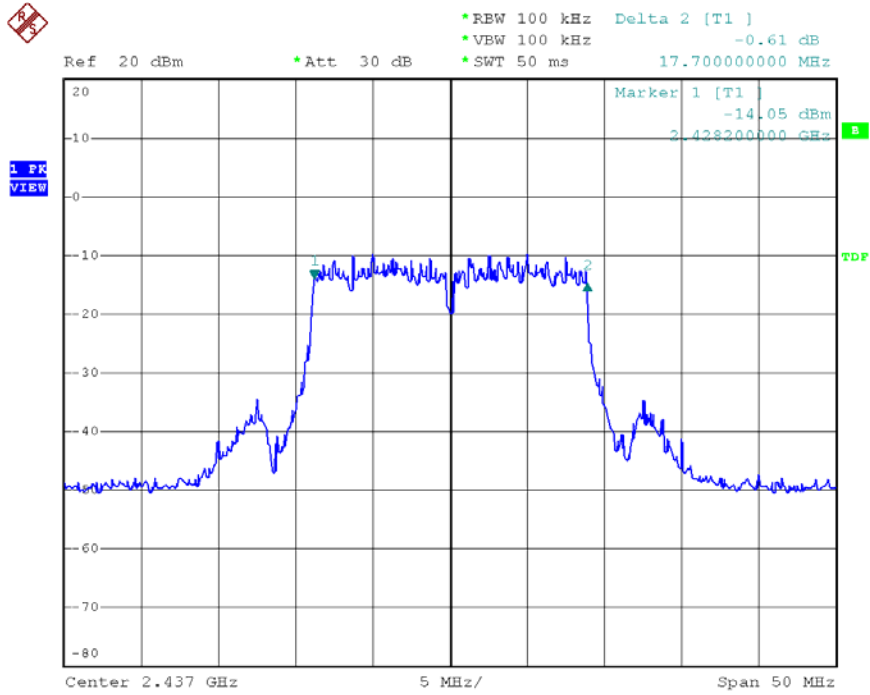

Date: 26.MAY.2008 15:28:26

Modulation Standard: 802.11n, HT20 (130Mbps) , ANT-R
 Channel: 11

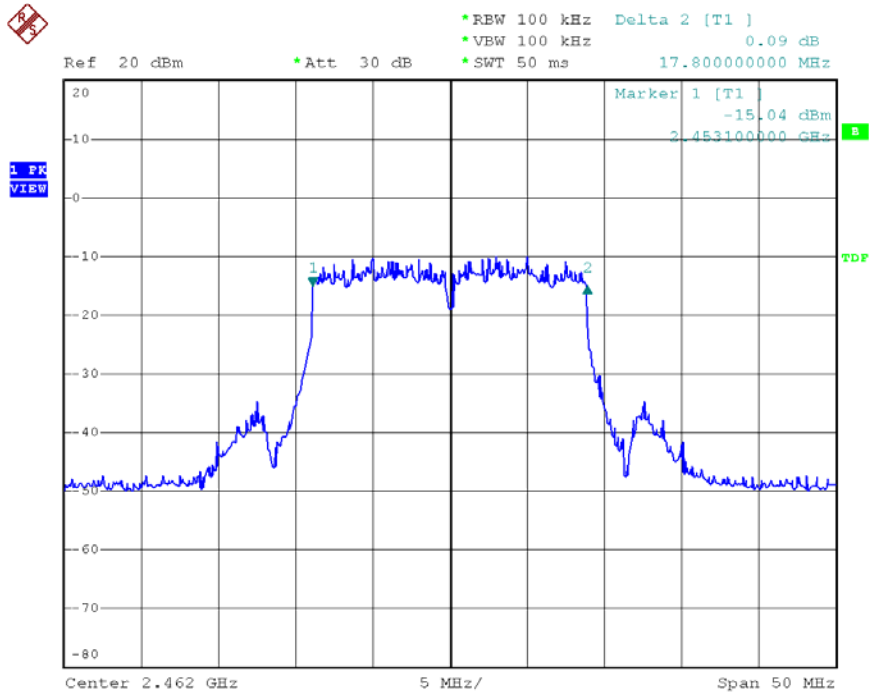

Date: 26.MAY.2008 15:30:52

Modulation Standard: 802.11n, HT40 (270Mbps) , ANT-L
 Channel: 03

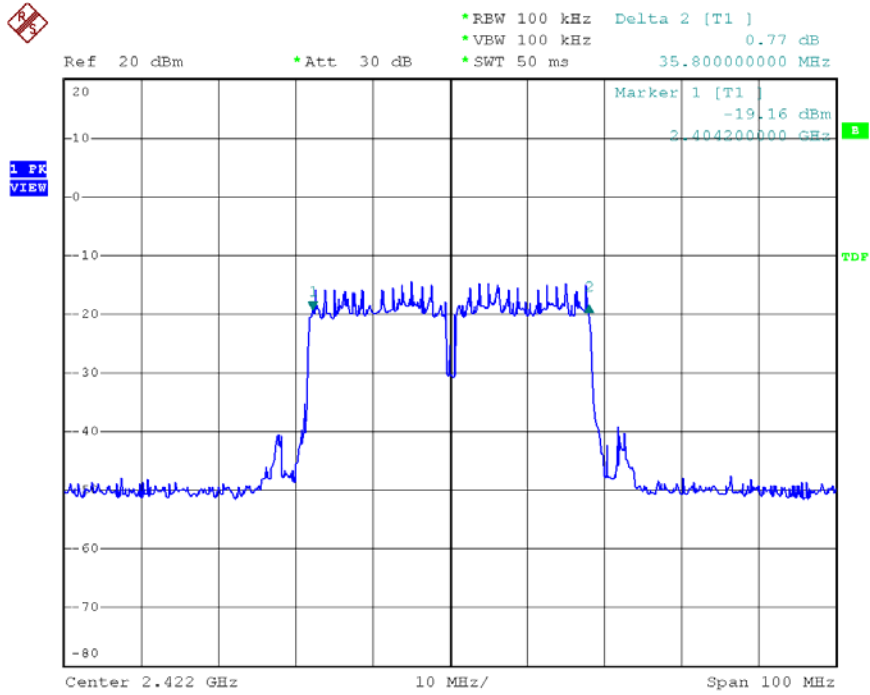

Date: 26.MAY.2008 19:05:39

Modulation Standard: 802.11n, HT40 (270Mbps) , ANT-L
 Channel: 06

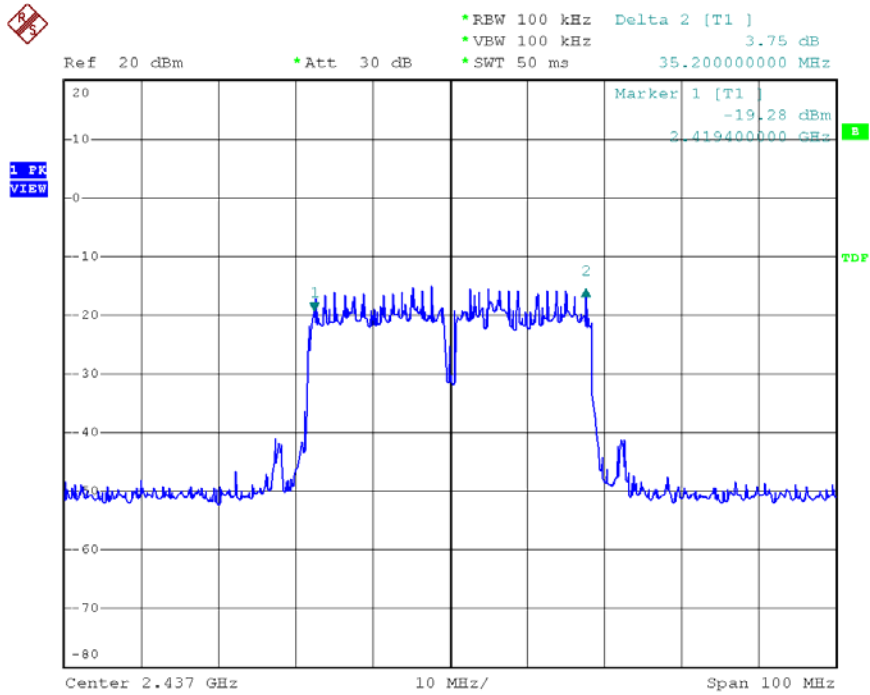

Date: 26.MAY.2008 19:03:48

Modulation Standard: 802.11n, HT40 (270Mbps) , ANT-L
 Channel: 09

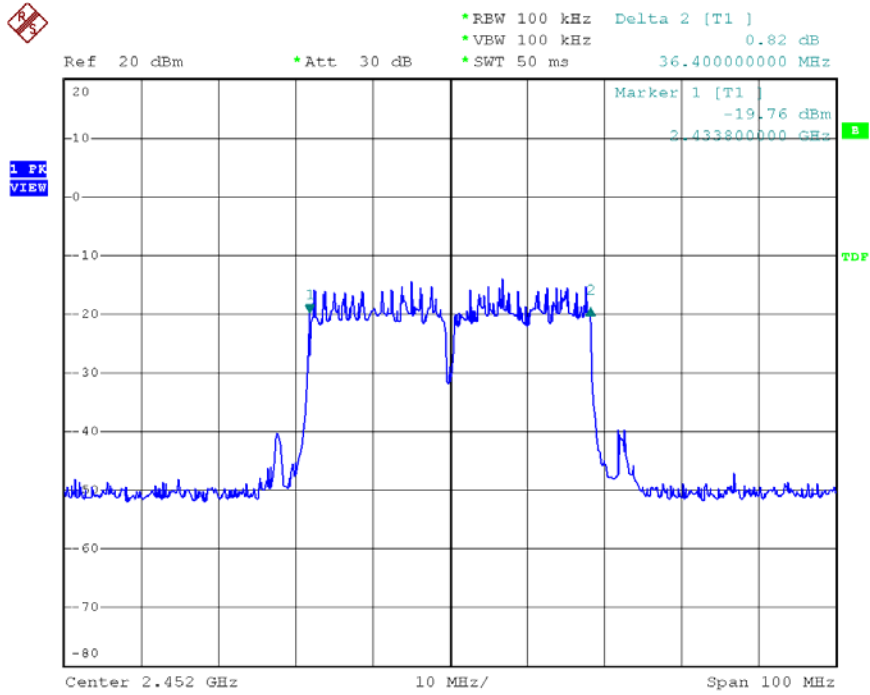

Date: 26.MAY.2008 19:00:50

Modulation Standard: 802.11n, HT40 (270Mbps) , ANT-R
 Channel: 03

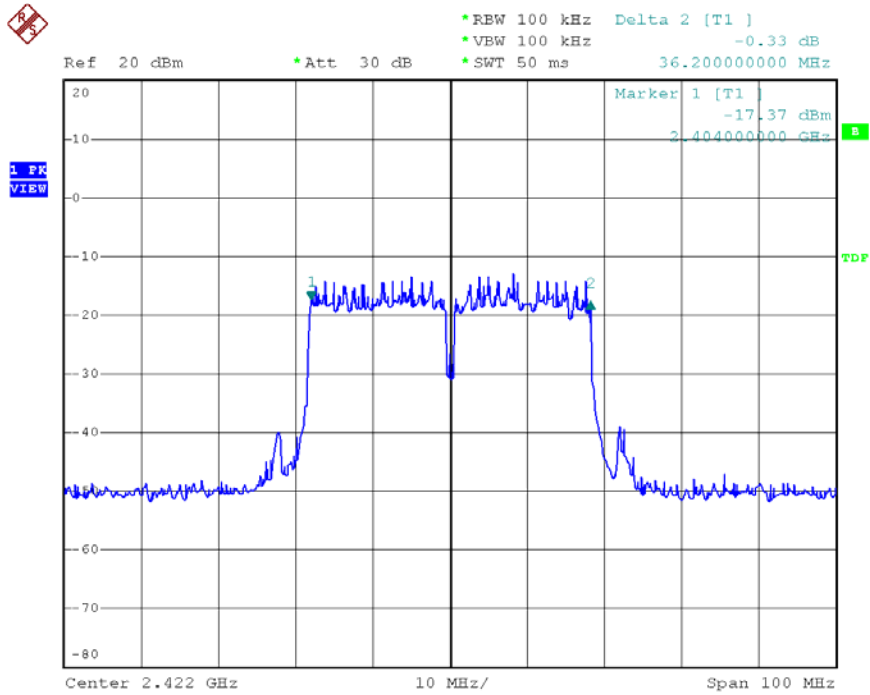

Date: 26.MAY.2008 19:08:46

Modulation Standard: 802.11n, HT40 (270Mbps) , ANT-R
 Channel: 06

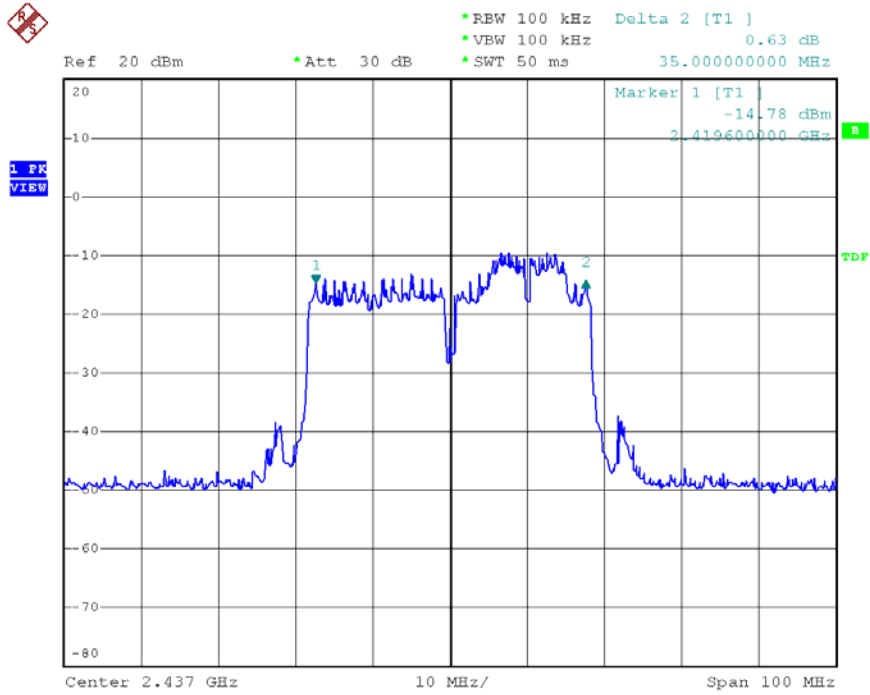

Date: 26.MAY.2008 19:18:49

Modulation Standard: 802.11n, HT40 (270Mbps) , ANT-R
 Channel: 09

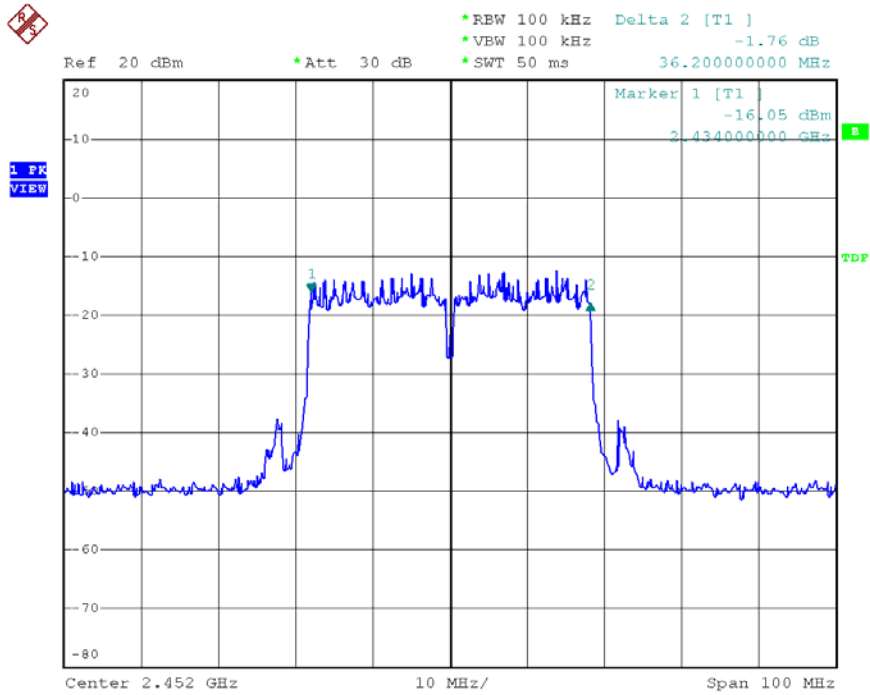

Date: 26.MAY.2008 19:20:37

7. Maximum Peak Output Power

7.1 Test Limit

The Maximum Peak Output Power Measurement is 30dBm.

7.2 Test Procedures

The antenna port(RF output)of the EUT was connected to the input(RF input)of a power meter. Power was read directly from the meter and cable loss connection was added to the reading to obtain power at the EUT antenna terminal. The EUT Output Power was set to maximum to produce the worse case test result.

7.3 Test Setup Layout

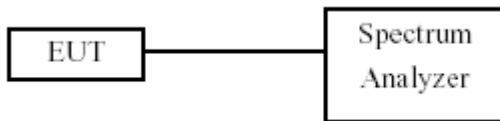

7.4 Measurement equipment

Instrument/Ancillary	Model No.	Manufacturer	Serial No.	Calibration Date	Valid Date
Spectrum Analyzer	FSP40	R&S	10047	2008/02/22	2009/02/21

7.5 Test Result and Data

- (1) Modulation Standard: IEEE 802.11b (11Mbps), ANT-L

Test Date: May. 26, 2008 Temperature: 20 Humidity: 60% Atmospheric pressure: 1008 hPa

Channel	Frequency (MHz)	Peak Power Output (dBm)	Peak Power Output (mW)
01	2412	16.95	49.50
06	2437	17.07	50.90
11	2462	17.01	50.20

- (2) Modulation Standard: IEEE 802.11g (54Mbps) , ANT-L

Test Date: May. 26, 2008 Temperature: 20 Humidity: 60% Atmospheric pressure: 1008 hPa

Channel	Frequency (MHz)	Peak Power Output (dBm)	Peak Power Output (mW)
01	2412	15.18	33.00
06	2437	15.18	33.00
11	2462	15.16	32.80

- (3) Modulation Standard: IEEE 802.11b (11Mbps), ANT-R

Test Date: May. 26, 2008 Temperature: 20 Humidity: 60% Atmospheric pressure: 1008 hPa

Channel	Frequency (MHz)	Peak Power Output (dBm)	Peak Power Output (mW)
01	2412	17.11	51.40
06	2437	16.98	49.90
11	2462	16.93	49.30

- (4) Modulation Standard: IEEE 802.11g (54Mbps) , ANT-R

Test Date: May. 26, 2008 Temperature: 20 Humidity: 60% Atmospheric pressure: 1008 hPa

Channel	Frequency (MHz)	Peak Power Output (dBm)	Peak Power Output (mW)
01	2412	15.24	33.40
06	2437	15.13	32.60
11	2462	15.10	32.40

- (5) Modulation Standard: IEEE 802.11n, HT20 (130Mbps),
 Test Date: May. 26, 2008 Temperature: 20 Humidity: 60% Atmospheric pressure: 1008 hPa

Channel	Frequency (MHz)	Peak Power Output (dBm)			Peak Power Output (mW)
		ANT-L	ANT-R	Total	ANT-R
01	2412	9.33	10.19	12.78	18.95
06	2437	9.07	10.10	12.63	18.31
11	2462	9.13	10.27	12.75	18.83

- (6) Modulation Standard: IEEE 802.11n, HT40 (270Mbps),
 Test Date: May. 26, 2008 Temperature: 20 Humidity: 60% Atmospheric pressure: 1008 hPa

Channel	Frequency (MHz)	Peak Power Output (dBm)			Peak Power Output (mW)
		ANT-L	ANT-R	Total	ANT-R
03	2422	8.25	9.86	12.14	16.37
06	2437	8.43	9.84	12.20	16.60
09	2452	8.39	9.95	12.25	16.79

Modulation Standard: 802.11b (11Mbps), ANT-L
 Channel: 01

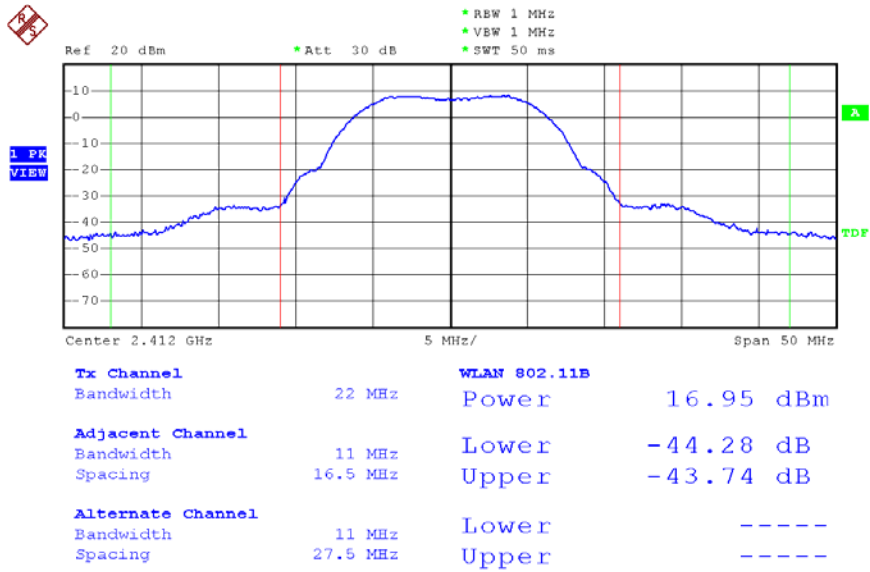

Date: 26.MAY.2008 10:36:54

Modulation Standard: 802.11b (11Mbps), ANT-L
 Channel: 06

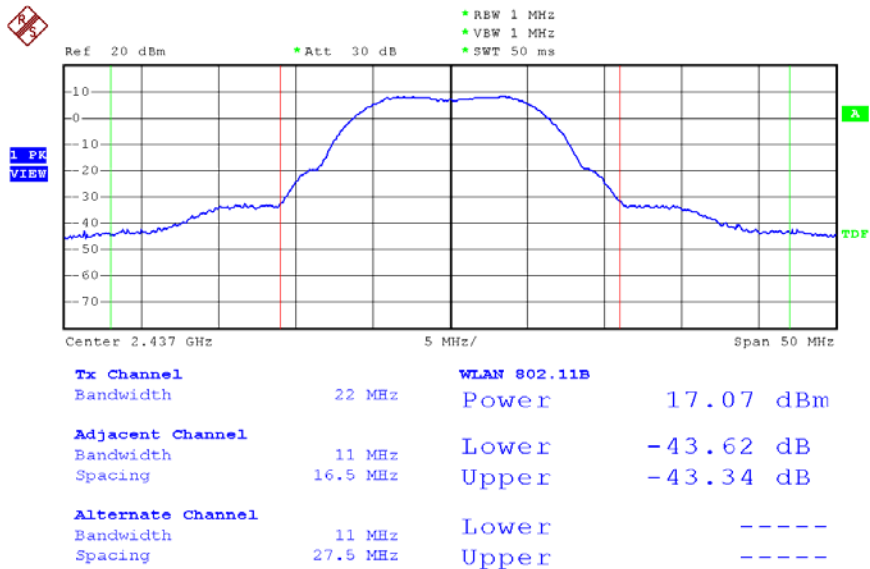

Date: 26.MAY.2008 10:37:36

Modulation Standard: 802.11b (11Mbps), ANT-L
 Channel: 11

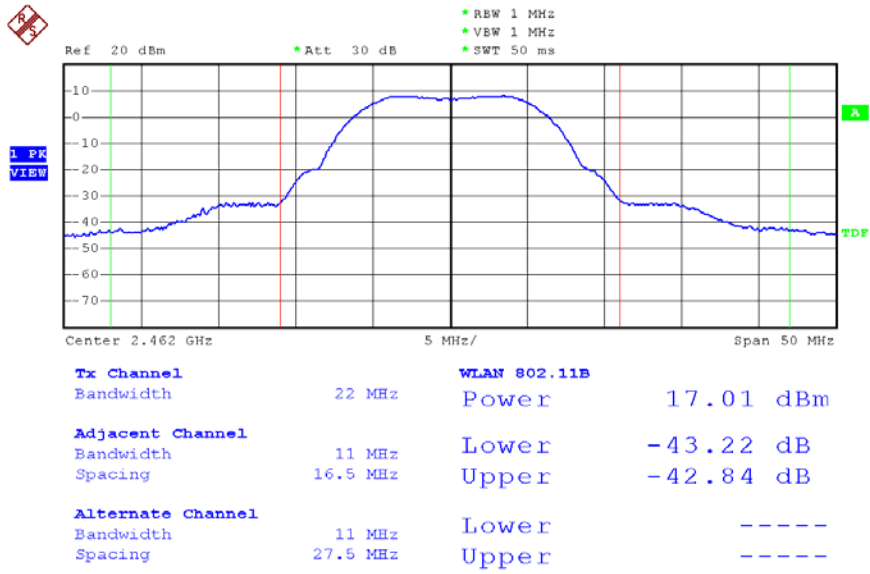

Date: 26.MAY.2008 10:39:02

Modulation Standard: 802.11g (54Mbps), ANT-L
 Channel: 01

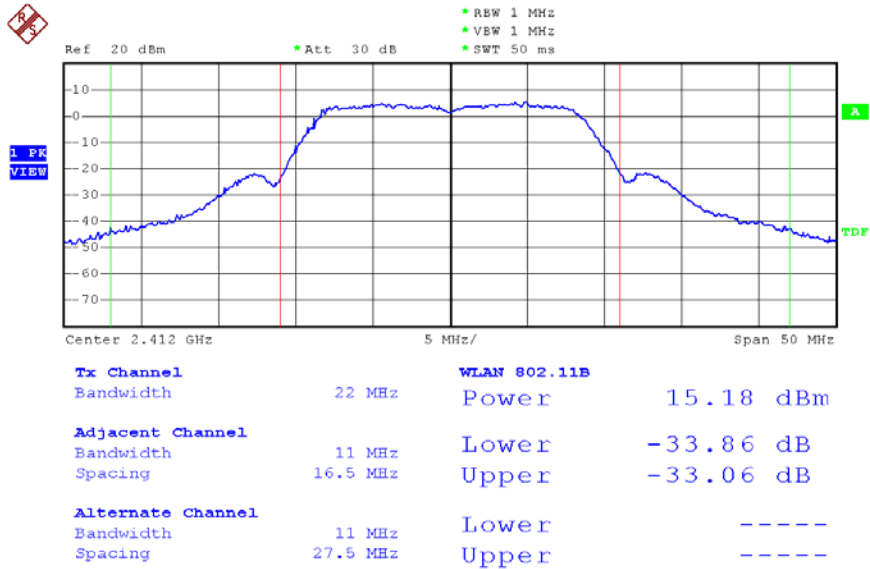

Date: 26.MAY.2008 10:43:51

Modulation Standard: 802.11g (54Mbps), ANT-L
 Channel: 06

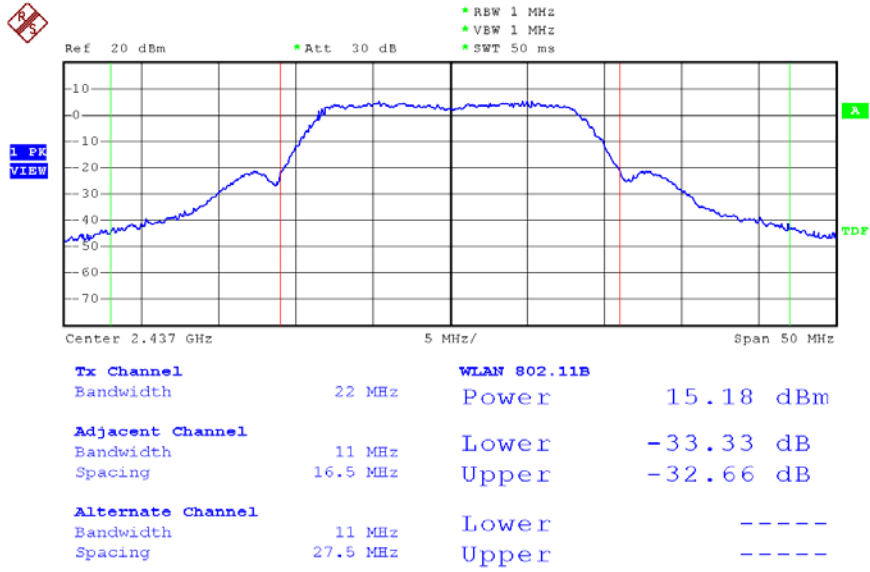

Date: 26.MAY.2008 10:44:46

Modulation Standard: 802.11g (54Mbps), ANT-L
 Channel: 11

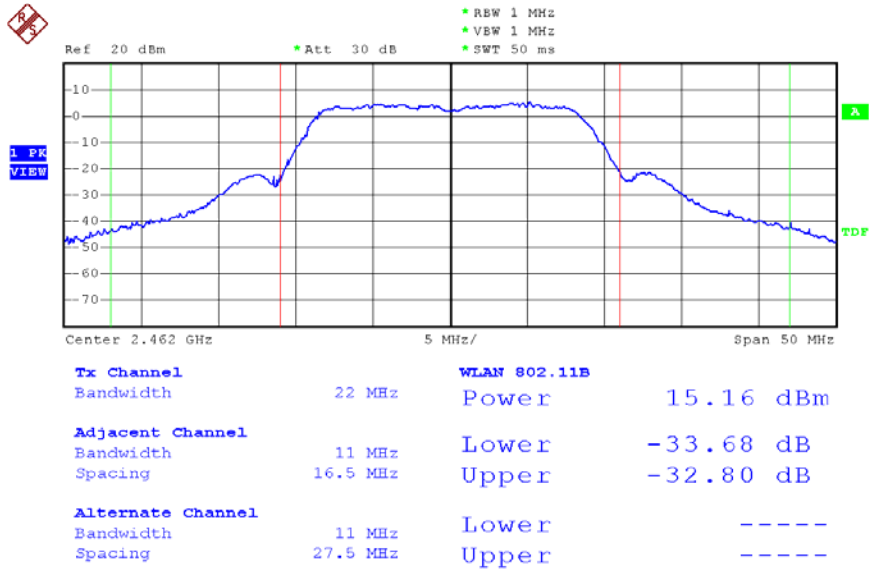

Date: 26.MAY.2008 10:46:07

Modulation Standard: 802.11b (11Mbps), ANT-R
 Channel: 01

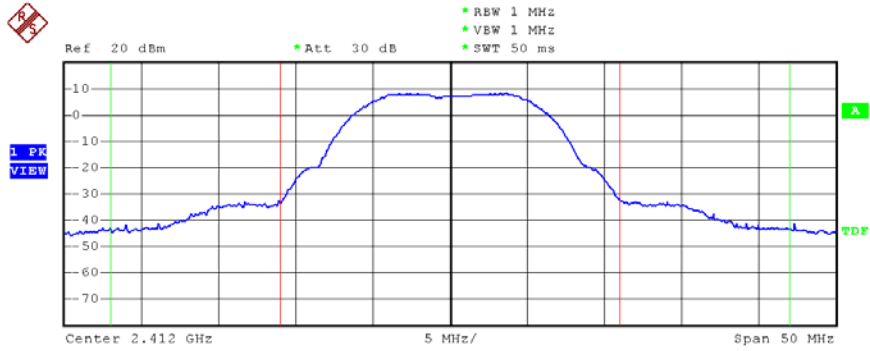

Tx Channel		WLAN 802.11B	
Bandwidth	22 MHz	Power	17.11 dBm
Adjacent Channel		Lower	-44.14 dB
Bandwidth	11 MHz	Upper	-43.70 dB
Spacing	16.5 MHz		
Alternate Channel		Lower	-----
Bandwidth	11 MHz	Upper	-----
Spacing	27.5 MHz		

Date: 26.MAY.2008 14:15:20

Modulation Standard: 802.11b (11Mbps), ANT-R
 Channel: 06

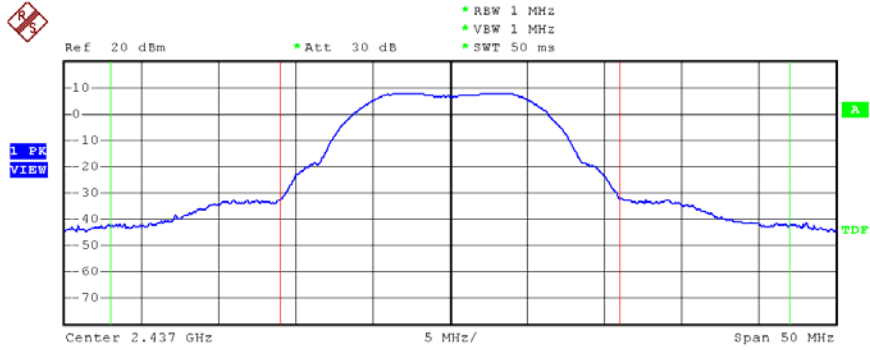

Tx Channel		WLAN 802.11B	
Bandwidth	22 MHz	Power	16.98 dBm
Adjacent Channel		Lower	-43.26 dB
Bandwidth	11 MHz	Upper	-43.04 dB
Spacing	16.5 MHz		
Alternate Channel		Lower	-----
Bandwidth	11 MHz	Upper	-----
Spacing	27.5 MHz		

Date: 26.MAY.2008 14:16:57

Modulation Standard: 802.11b (11Mbps), ANT-R
 Channel: 11

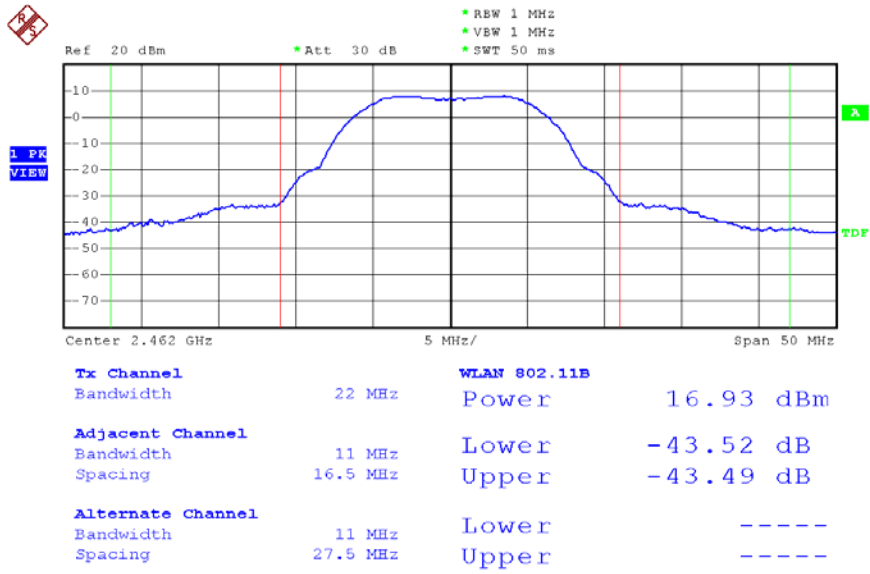

Date: 26.MAY.2008 14:19:37

Modulation Standard: 802.11g (54Mbps), ANT-R
 Channel: 01

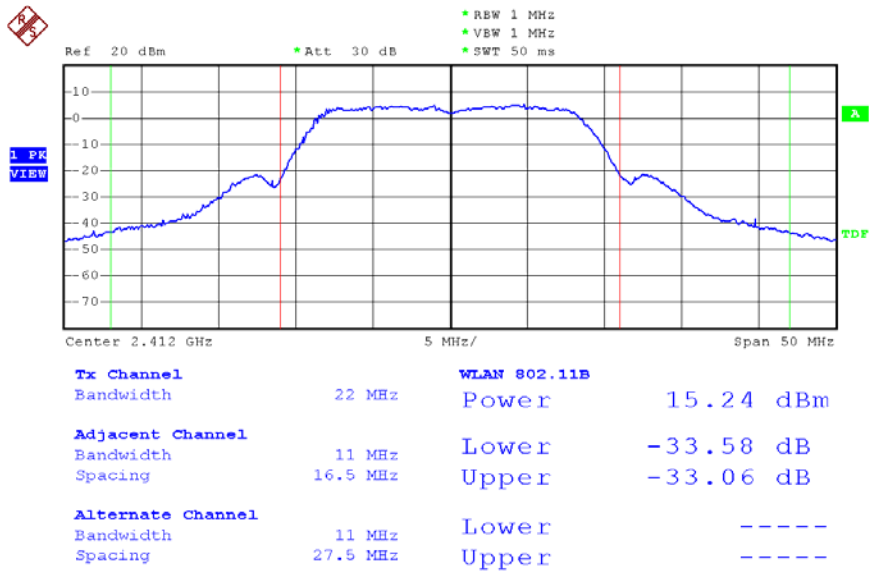

Date: 26.MAY.2008 14:20:46

Modulation Standard: 802.11g (54Mbps), ANT-R
 Channel: 06

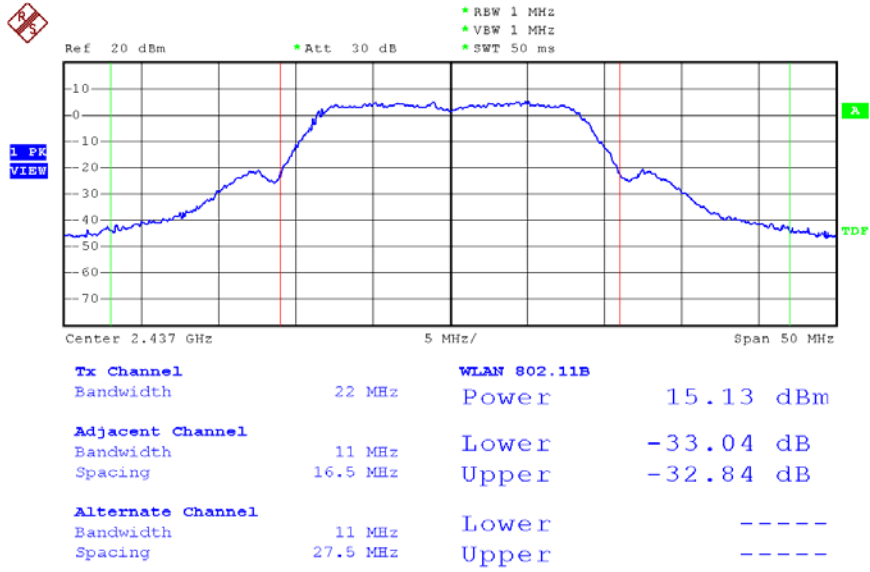

Date: 26.MAY.2008 14:21:18

Modulation Standard: 802.11g (54Mbps), ANT-R
 Channel: 11

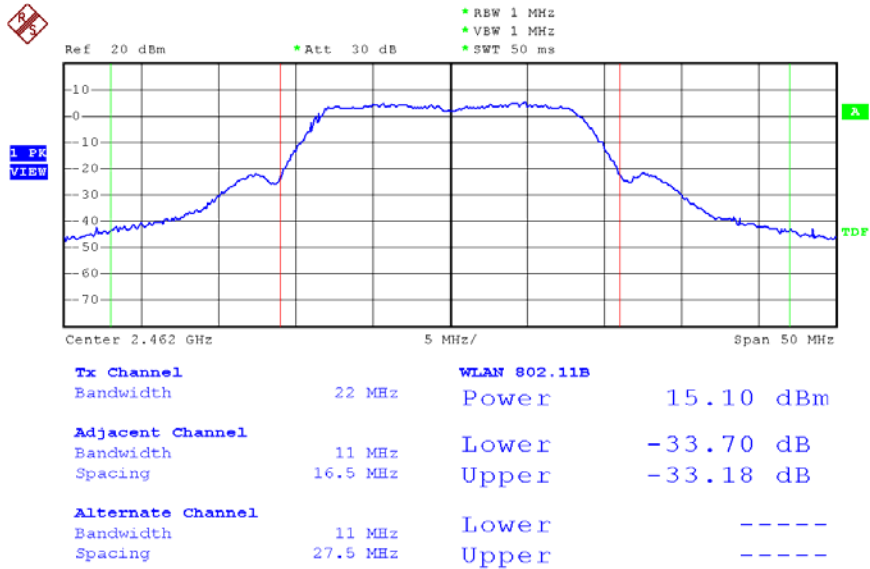

Date: 26.MAY.2008 14:22:48

Modulation Standard: 802.11n, HT20 (130Mbps) , ANT-L
 Channel: 01

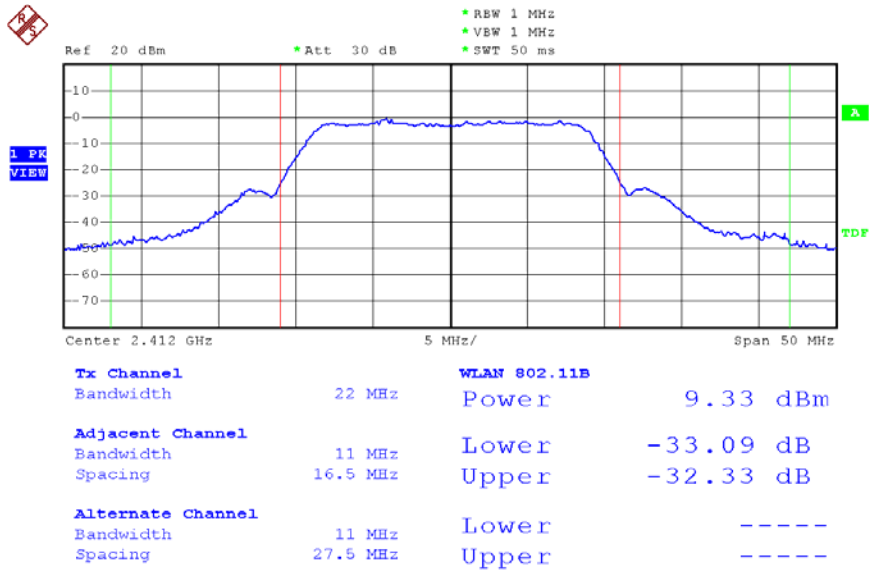

Date: 26.MAY.2008 15:07:17

Modulation Standard: 802.11n, HT20 (130Mbps) , ANT-L
 Channel: 06

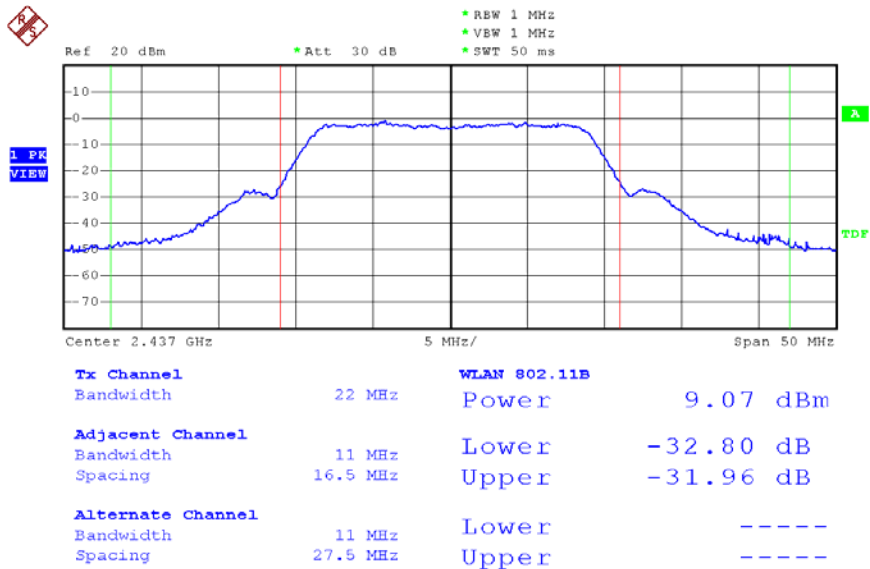

Date: 26.MAY.2008 15:10:16

Modulation Standard: 802.11n, HT20 (130Mbps) , ANT-L
 Channel: 11

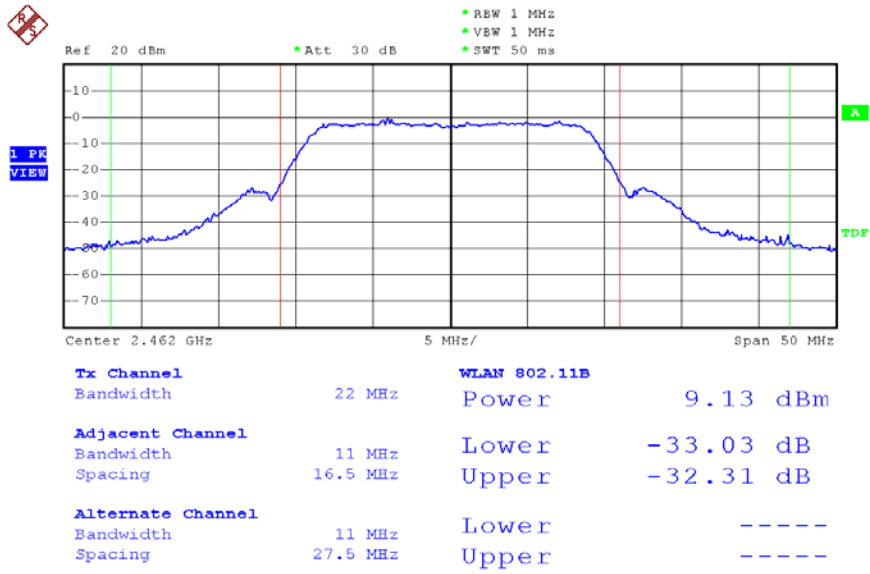

Date: 26.MAY.2008 15:15:30

Modulation Standard: 802.11n, HT20 (130Mbps) , ANT-R
 Channel: 01

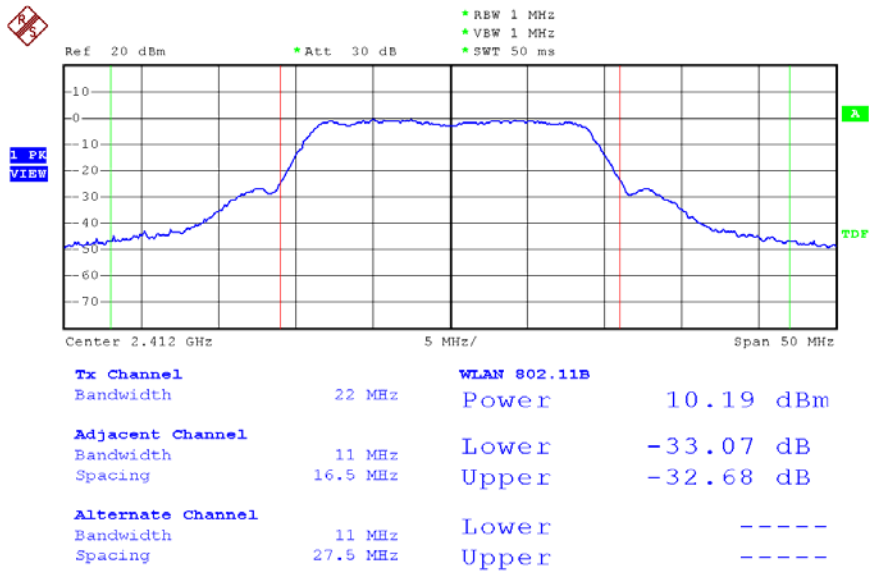

Date: 26.MAY.2008 15:07:58

Modulation Standard: 802.11n, HT20 (130Mbps) , ANT-R
 Channel: 06

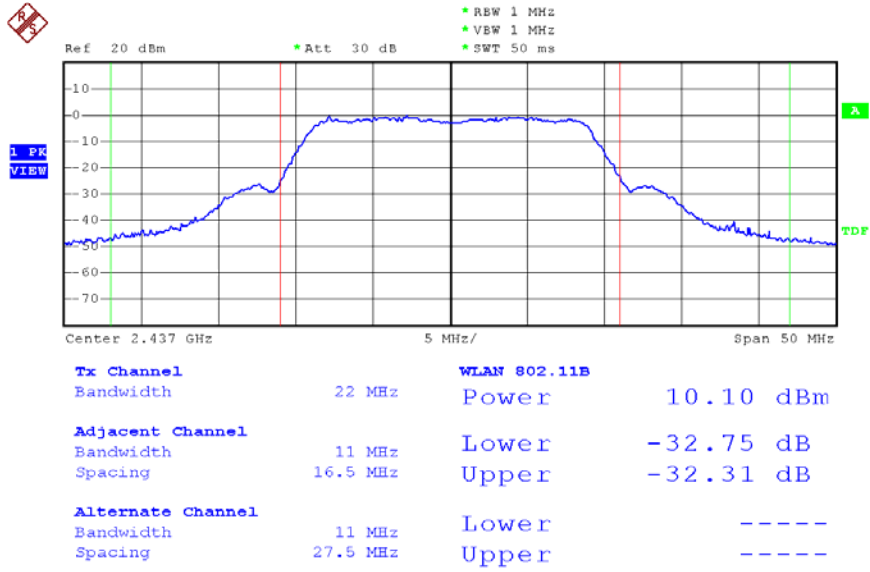

Date: 26.MAY.2008 15:11:09

Modulation Standard: 802.11n, HT20 (130Mbps) , ANT-R
 Channel: 11

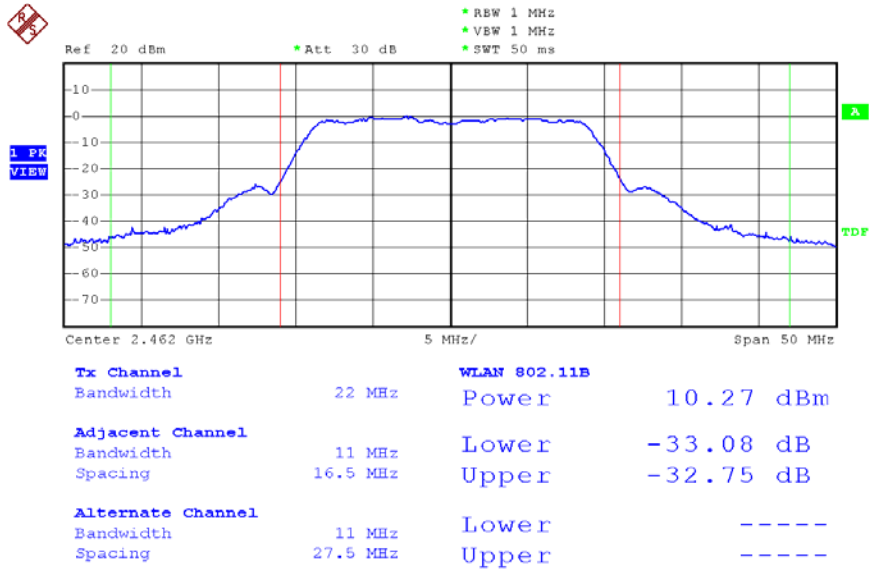

Date: 26.MAY.2008 15:12:19

Modulation Standard: 802.11n, HT40 (270Mbps) , ANT-L
 Channel: 03

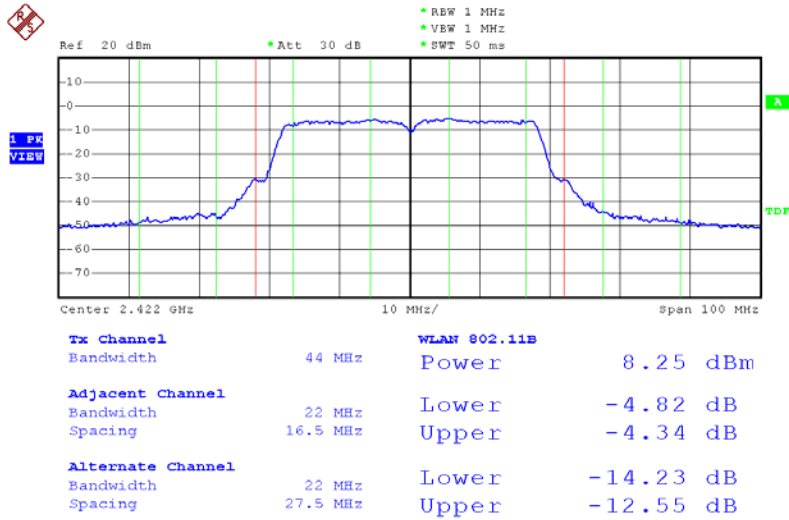

Date: 26.MAY.2008 18:51:45

Modulation Standard: 802.11n, HT40 (270Mbps) , ANT-L
 Channel: 06

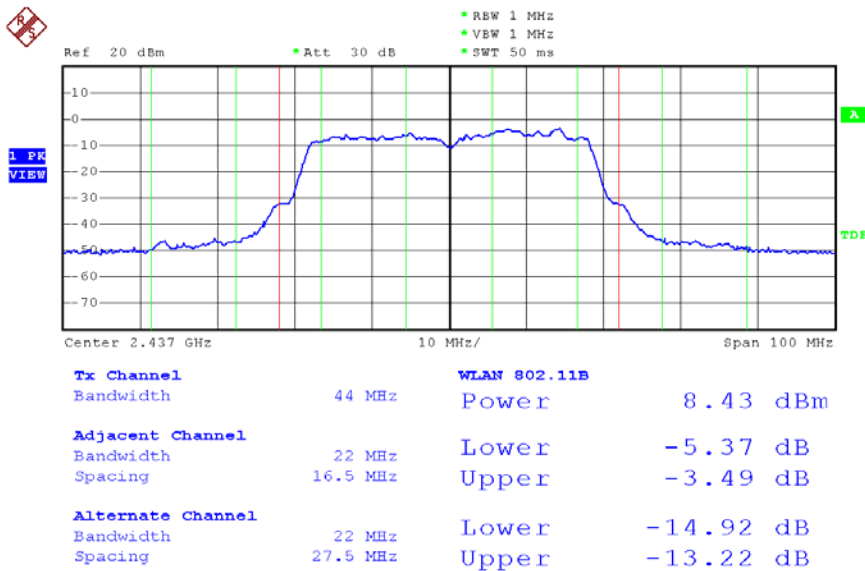

Date: 26.MAY.2008 18:53:41

Modulation Standard: 802.11n, HT40 (270Mbps) , ANT-L
 Channel: 09

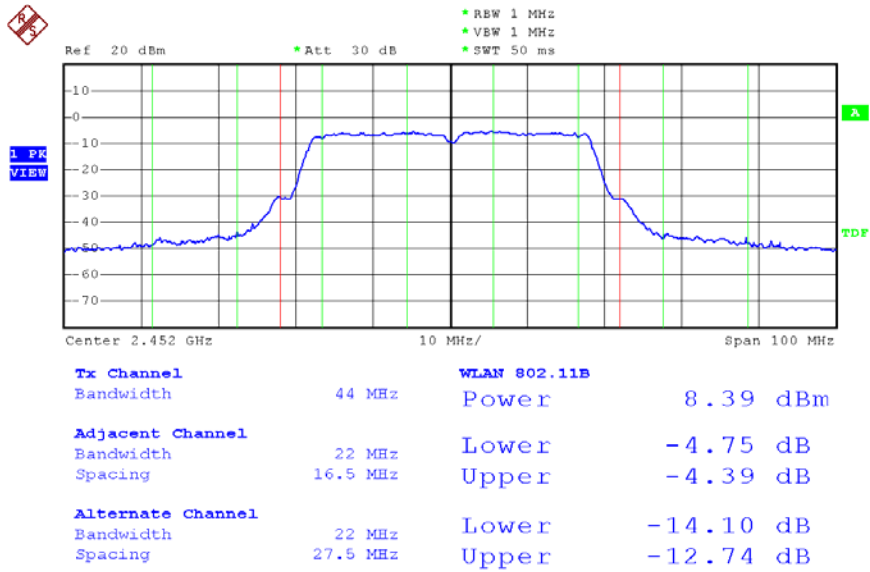

Date: 26.MAY.2008 18:57:39

Modulation Standard: 802.11n, HT40 (270Mbps) , ANT-R
 Channel: 03

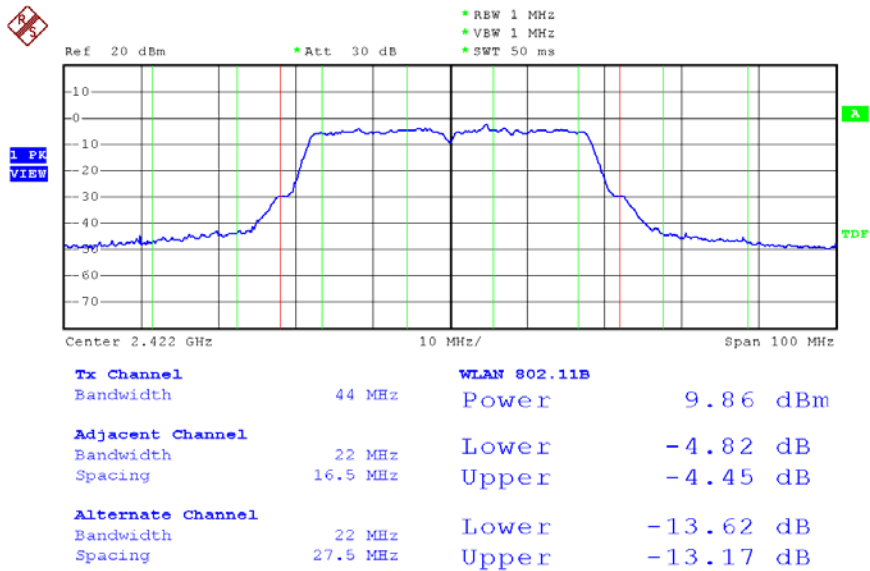

Date: 26.MAY.2008 18:48:57

Modulation Standard: 802.11n, HT40 (270Mbps) , ANT-R
 Channel: 06

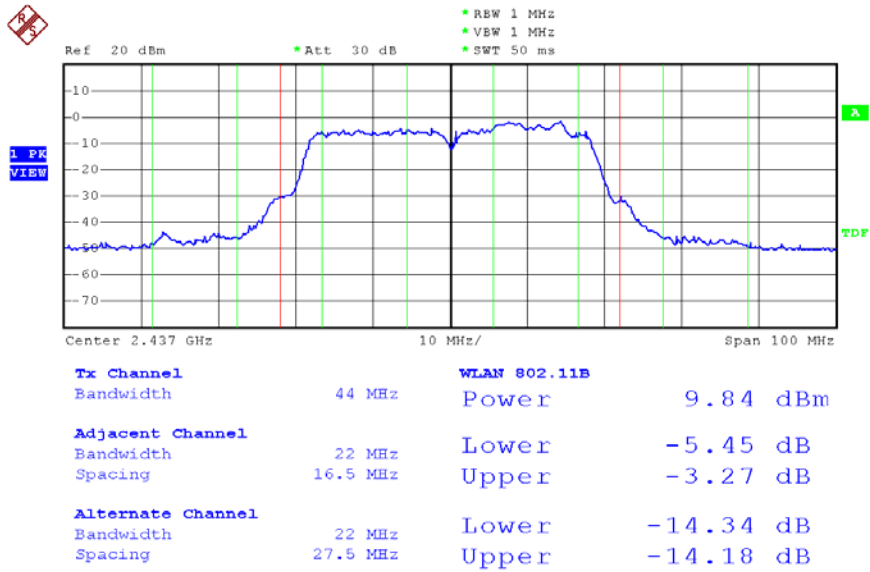

Date: 26.MAY.2008 18:54:41

Modulation Standard: 802.11n, HT40 (270Mbps) , ANT-R
 Channel: 09

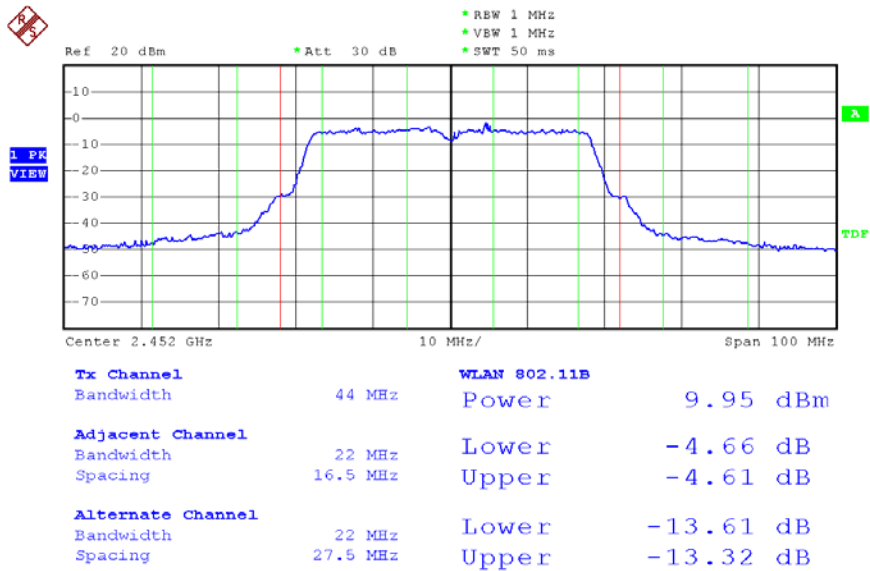

Date: 26.MAY.2008 18:56:01

8. Band Edges Measurement

8.1 Test Limit

Below -20dB of the highest emission level of operating band (In 100 kHz Resolution Bandwidth)

8.2 Test Procedure :

- a. The transmitter output was connected to the spectrum analyzer via a low lose cable.
- b. Set both RBW and VBW of spectrum analyzer to 100 KHz with convenient frequency span including 100 KHz bandwidth from band edge.
- c. The band edges was measured and recorded.

8.3 Test Setup Layout

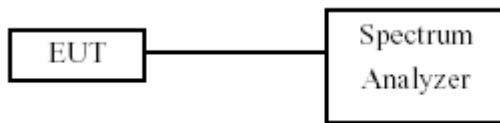

8.4 Measurement equipment

Instrument/Ancillary	Model No.	Manufacturer	Serial No.	Calibration Date	Valid Date
Spectrum Analyzer	FSP40	R&S	10047	2008/02/22	2009/02/21

8.5 Test Result and Data

- (1) Modulation Standard: IEEE 802.11b (11Mbps), ANT-L

Test Date: May. 26, 2008 Temperature: 20 Humidity: 60% Atmospheric pressure: 1008 hPa

Channel	Frequency	maximum value in frequency (MHz)	maximum value is (dBm)
01	2412	2397.60	-42.12
11	2462	7360.00	-48.11

- (2) Modulation Standard: IEEE 802.11g (54Mbps) , ANT-L

Test Date: May. 26, 2008 Temperature: 20 Humidity: 60% Atmospheric pressure: 1008 hPa

Channel	Frequency	maximum value in frequency (MHz)	maximum value is (dBm)
01	2412	2399.60	-30.47
11	2462	2483.70	-53.78

- (3) Modulation Standard: IEEE 802.11b (11Mbps), ANT-R

Test Date: May. 26, 2008 Temperature: 20 Humidity: 60% Atmospheric pressure: 1008 hPa

Channel	Frequency	maximum value in frequency (MHz)	maximum value is (dBm)
01	2412	2397.90	-42.10
11	2462	2485.10	-51.75

- (4) Modulation Standard: IEEE 802.11g (54Mbps) , ANT-R

Test Date: May. 26, 2008 Temperature: 20 Humidity: 60% Atmospheric pressure: 1008 hPa

Channel	Frequency	maximum value in frequency (MHz)	maximum value is (dBm)
01	2412	2399.40	-30.90
11	2462	4885.00	-53.05

(5) Modulation Standard: IEEE 802.11n, HT20 (130Mbps),

Test Date: May. 26, 2008 Temperature: 20 Humidity: 60% Atmospheric pressure: 1008 hPa

Channel	Frequency	maximum value in frequency of ANT-L (MHz)	maximum value of ANT-L is (dBm)	maximum value in frequency of ANT-R (MHz)	maximum value of ANT-R is (dBm)
01	2412	2399.40	-36.03	2399.60	-35.38
11	2462	2533.30	-56.56	3265.00	-53.53

(6) Modulation Standard: IEEE 802.11n, HT40 (270Mbps),

Test Date: May. 26, 2008 Temperature: 20 Humidity: 60% Atmospheric pressure: 1008 hPa

Channel	Frequency	maximum value in frequency of ANT-L (MHz)	maximum value of ANT-L is (dBm)	maximum value in frequency of ANT-R (MHz)	maximum value of ANT-R is (dBm)
03	2422	2399.40	-41.42	2399.40	-39.36
09	2452	2489.50	-55.04	2483.90	-54.53

Modulation Standard: 802.11b (11Mbps), ANT-L
 Channel: 01

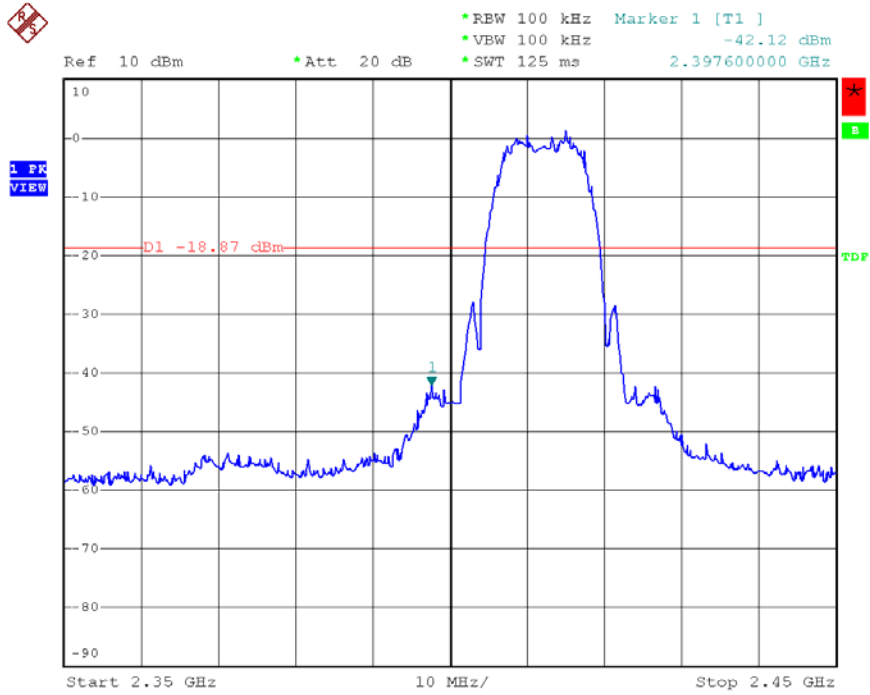

Date: 26.MAY.2008 11:04:35

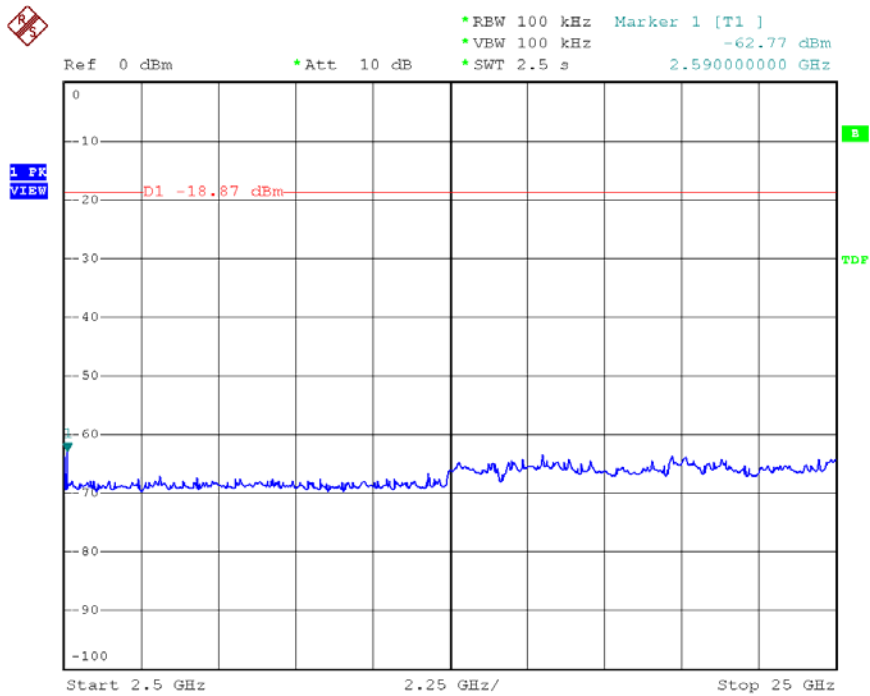

Date: 26.MAY.2008 11:05:16

Modulation Standard: 802.11b (11Mbps), ANT-L
 Channel: 11

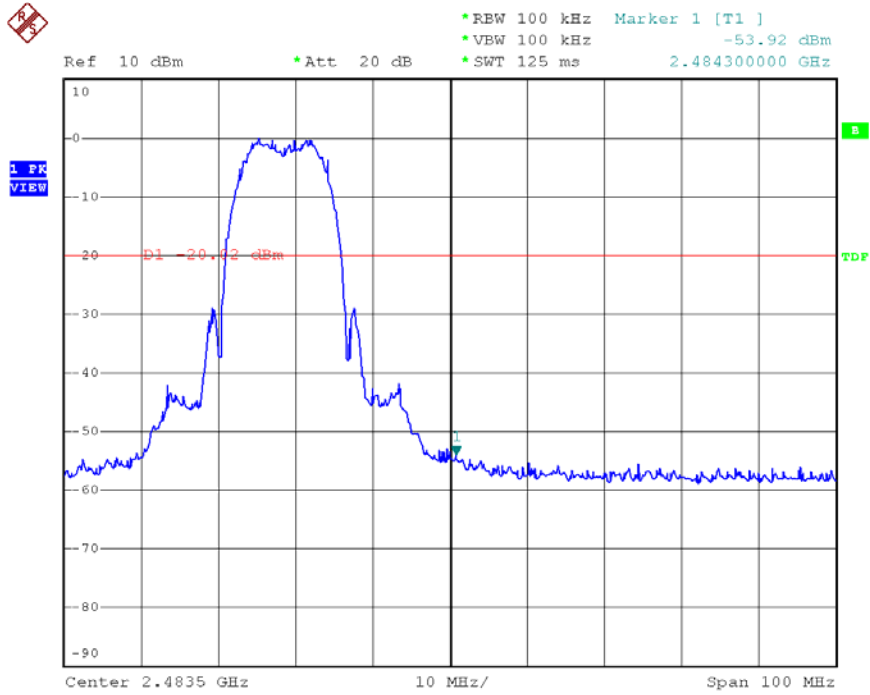

Date: 26.MAY.2008 11:06:48

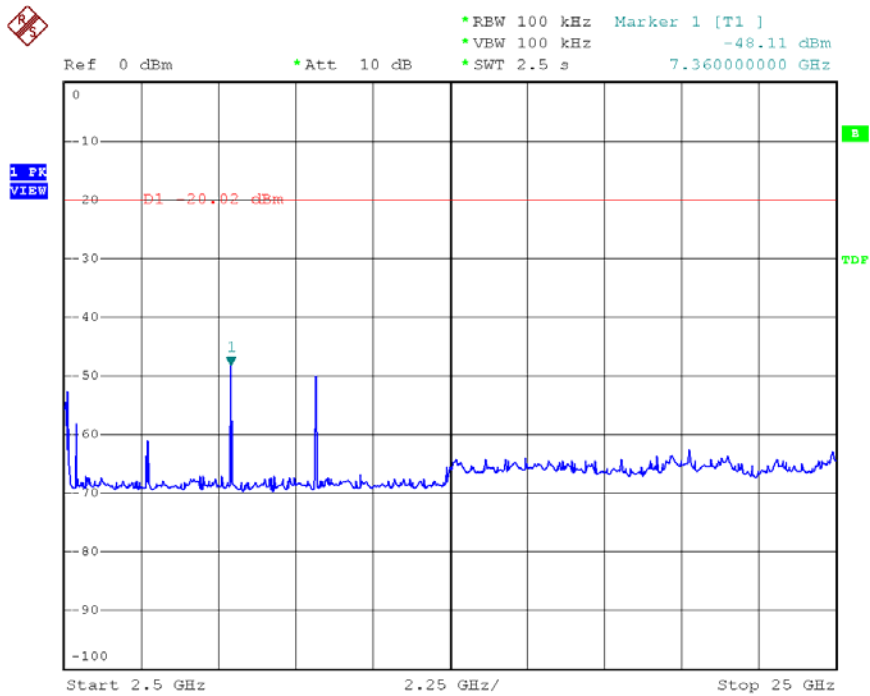

Date: 26.MAY.2008 11:08:26

Modulation Standard: 802.11g (54Mbps), ANT-L
 Channel: 01

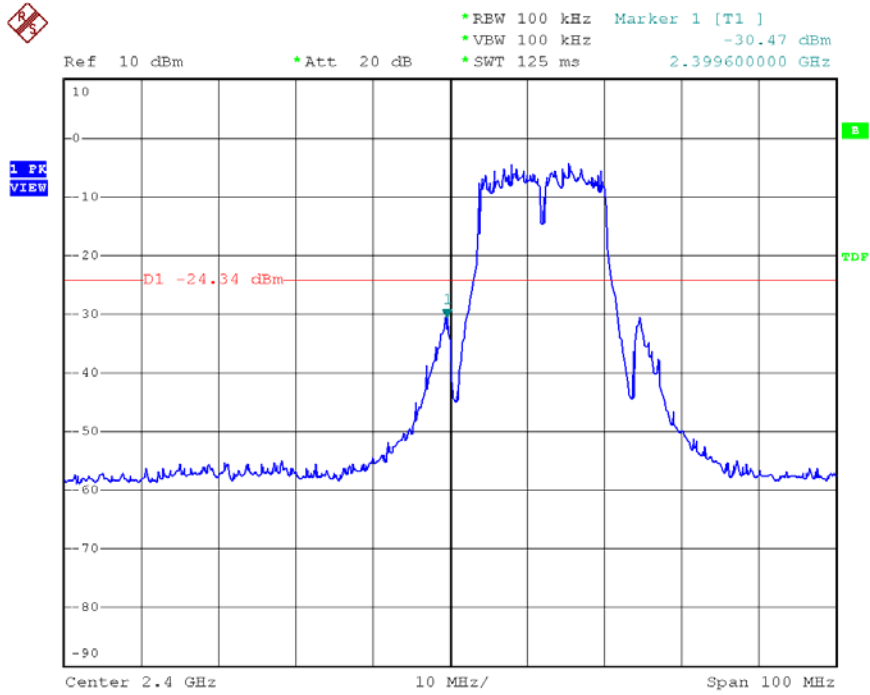

Date: 26.MAY.2008 11:10:49

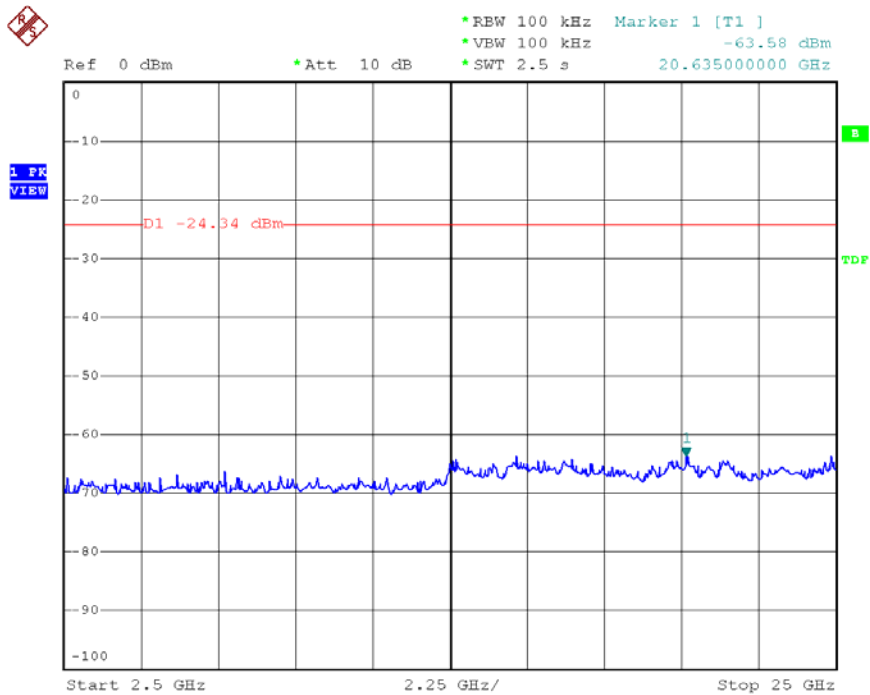

Date: 26.MAY.2008 11:11:28

Modulation Standard: 802.11g (54Mbps), ANT-L
 Channel: 11

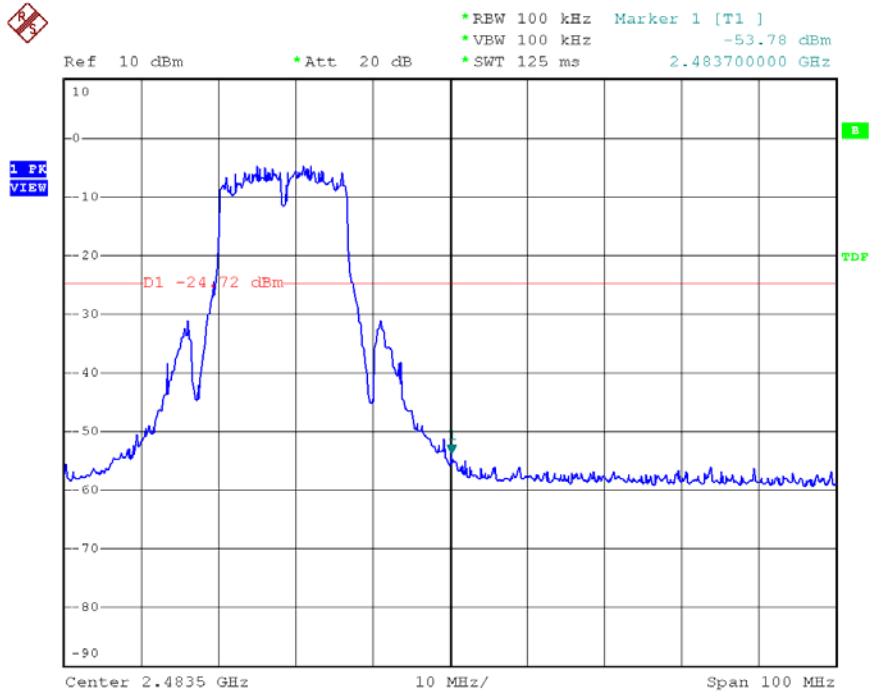

Date: 26.MAY.2008 11:12:49

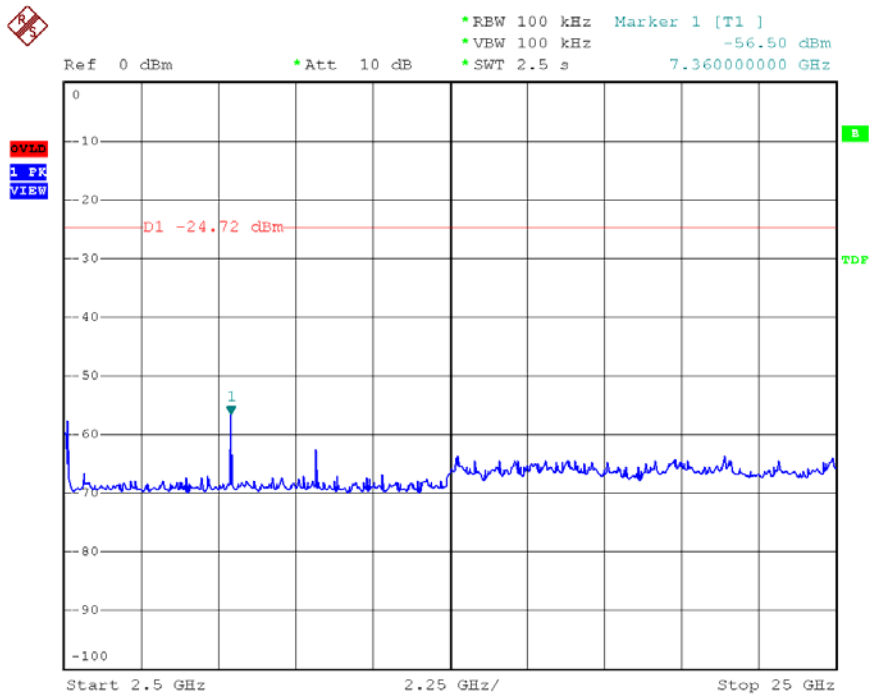

Date: 26.MAY.2008 11:13:25

Modulation Standard: 802.11b (11Mbps), ANT-R
 Channel: 01

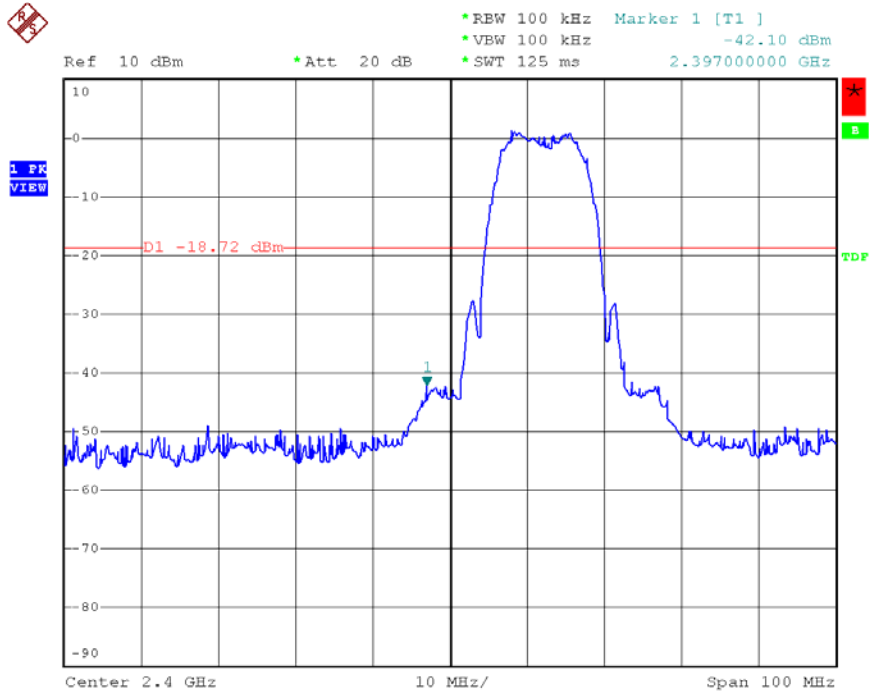

Date: 26.MAY.2008 14:39:34

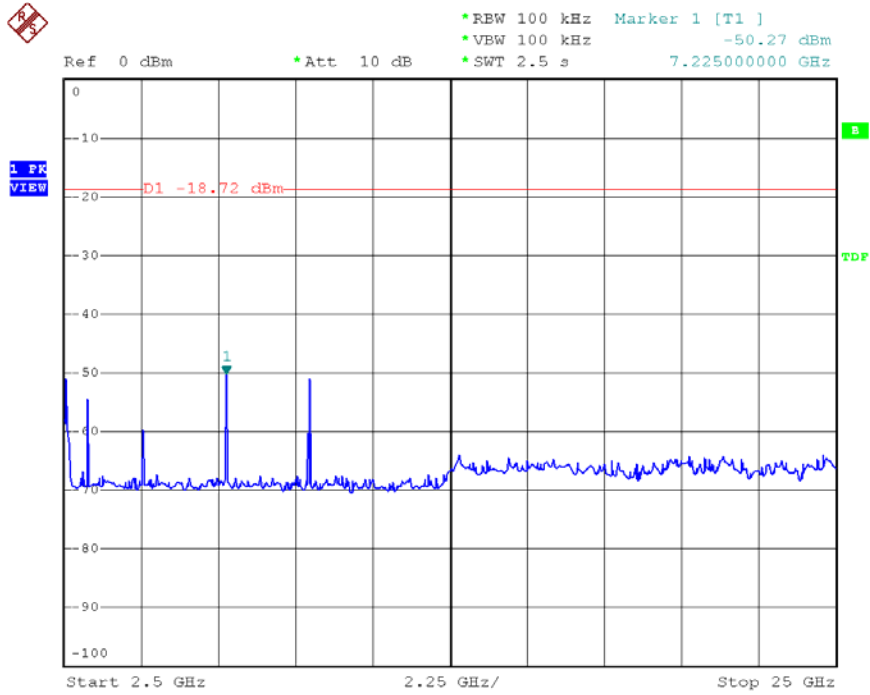

Date: 26.MAY.2008 14:40:01

Modulation Standard: 802.11b (11Mbps), ANT-R
 Channel: 11

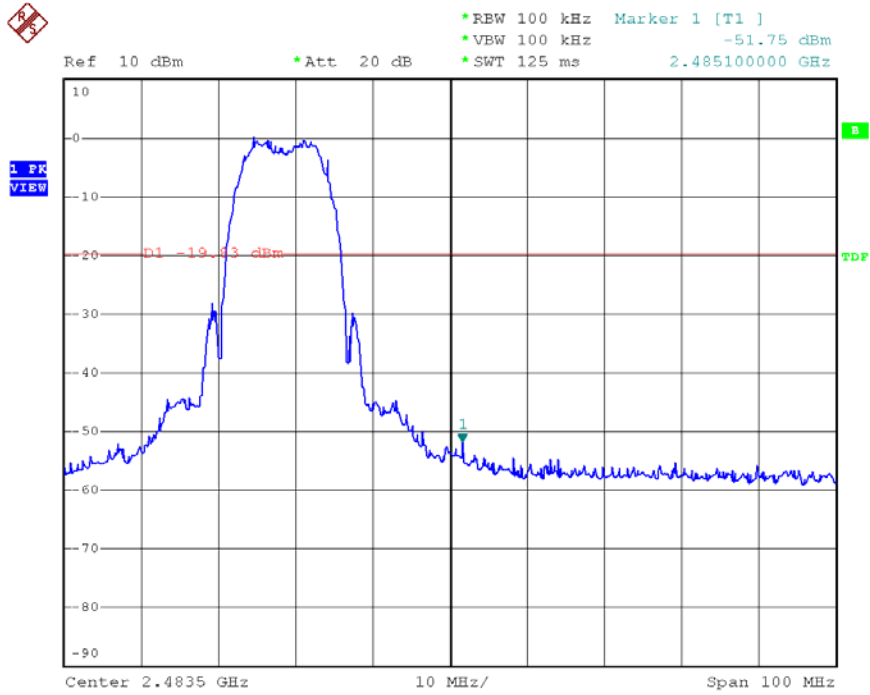

Date: 26.MAY.2008 14:40:53

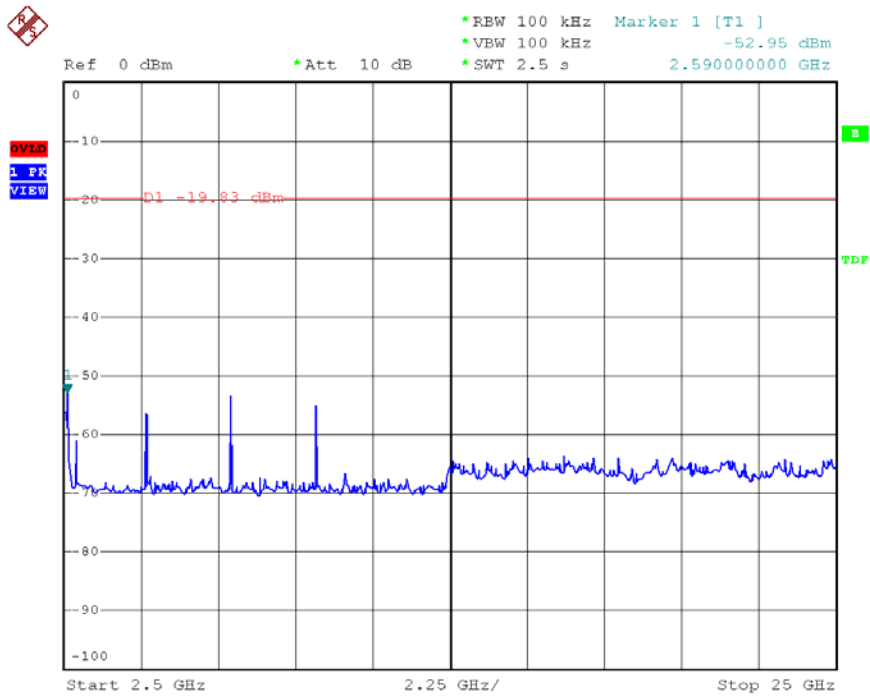

Date: 26.MAY.2008 14:41:32

Modulation Standard: 802.11g (54Mbps), ANT-R
 Channel: 01

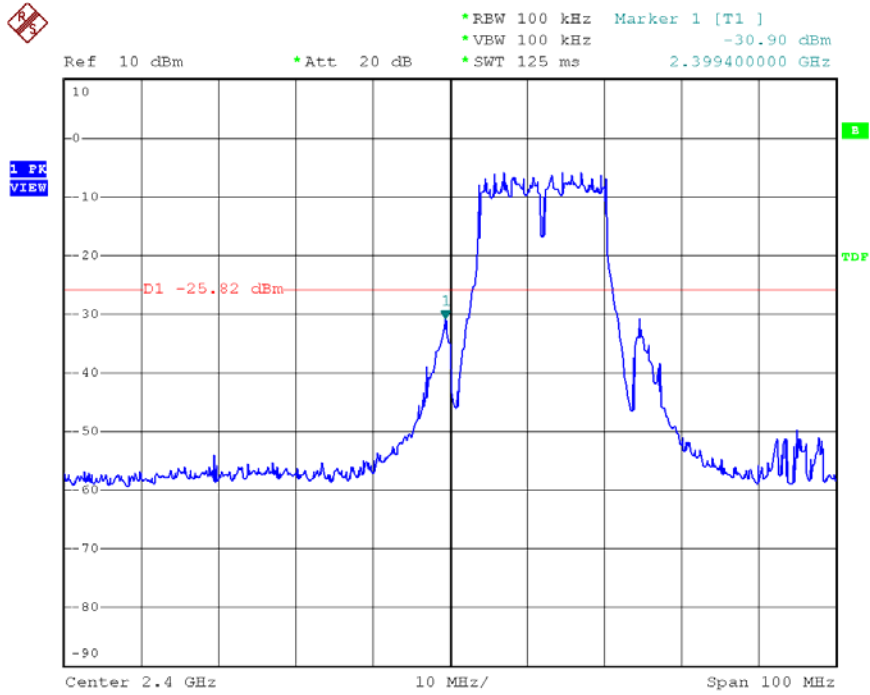

Date: 26.MAY.2008 14:43:01

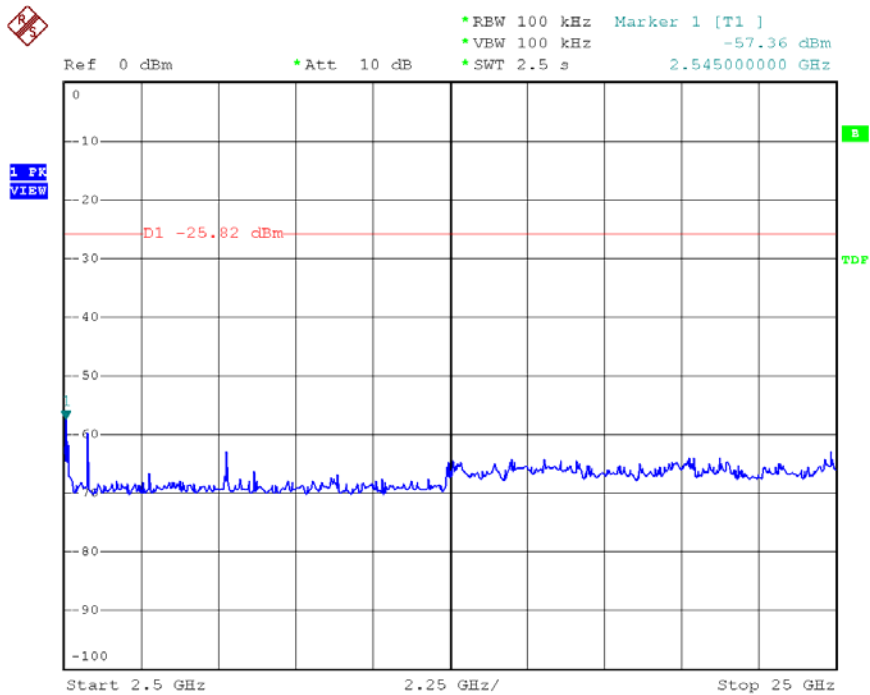

Date: 26.MAY.2008 14:43:37

Modulation Standard: 802.11g (54Mbps), ANT-R
 Channel: 11

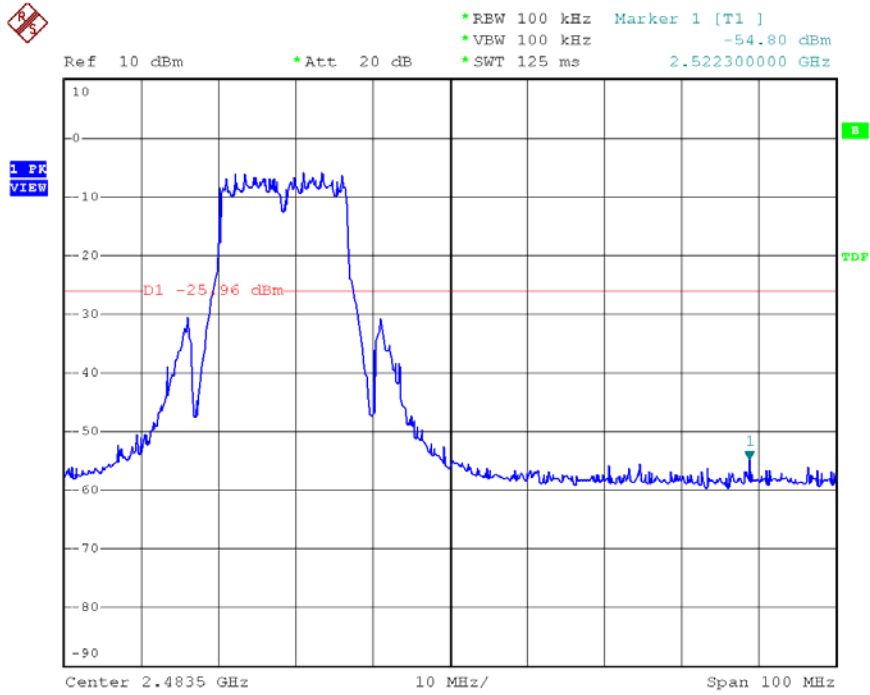

Date: 26.MAY.2008 14:45:00

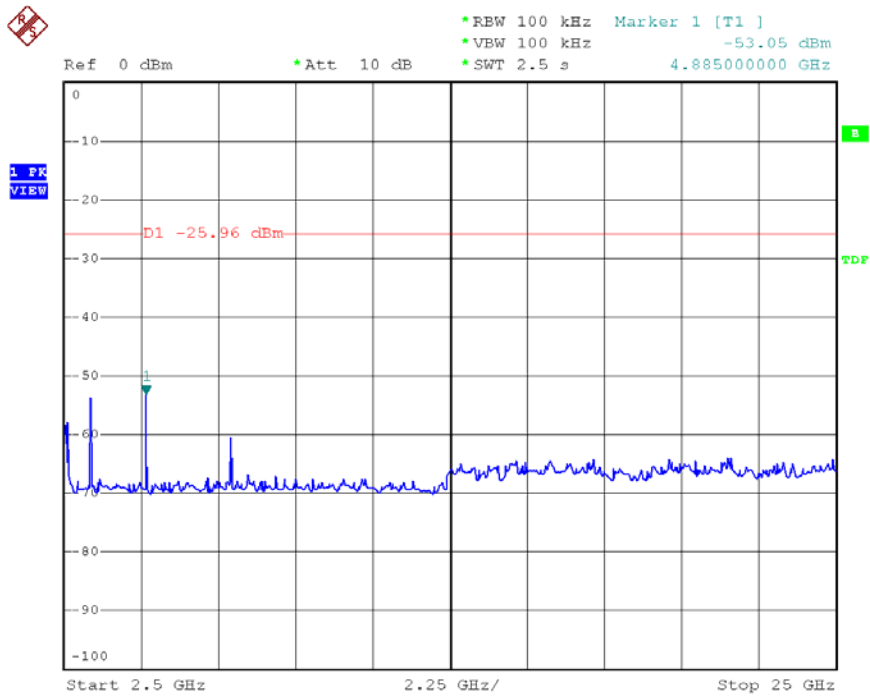

Date: 26.MAY.2008 14:45:45

Modulation Standard: 802.11n, HT20 (130Mbps), ANT-L
 Channel: 01

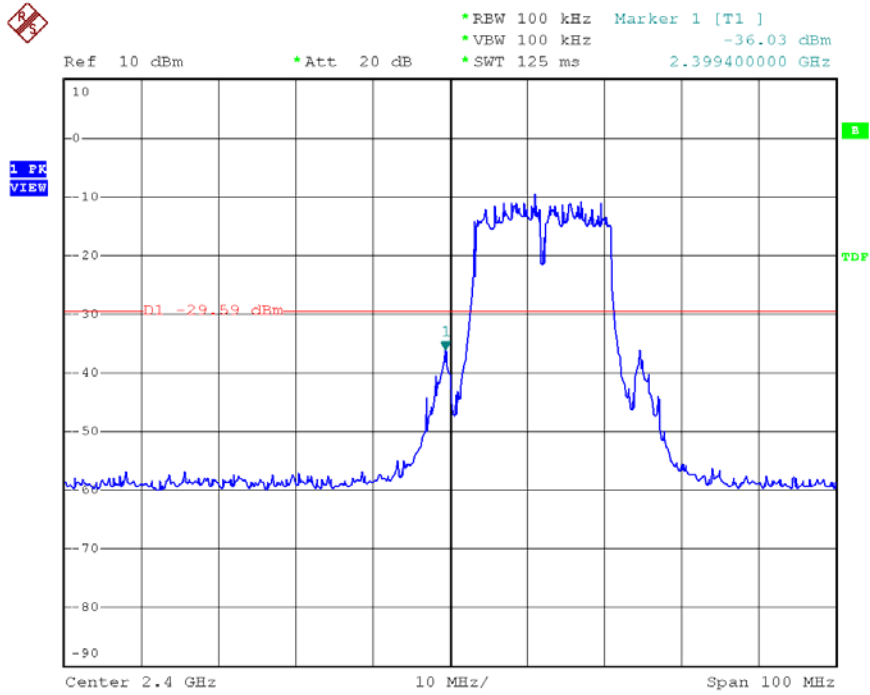

Date: 26.MAY.2008 15:40:42

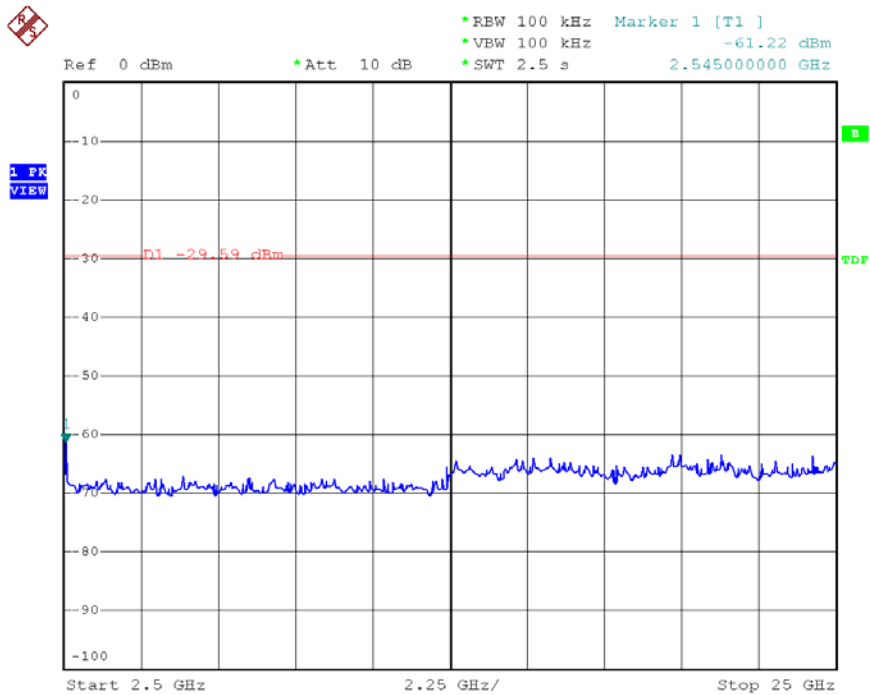

Date: 26.MAY.2008 15:41:16

Modulation Standard: 802.11n, HT20 (130Mbps), ANT-L
 Channel: 11

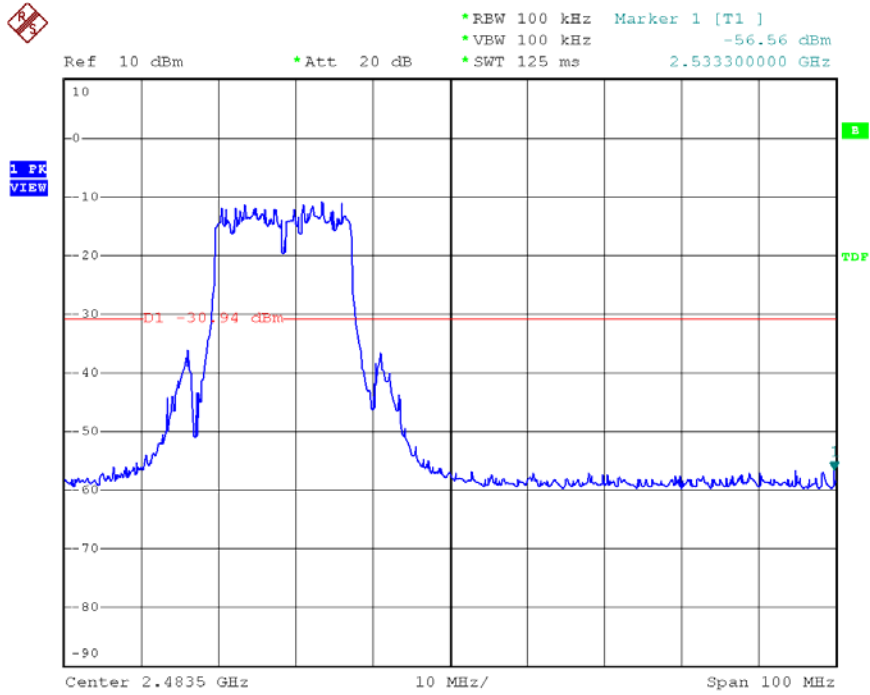

Date: 26.MAY.2008 15:43:19

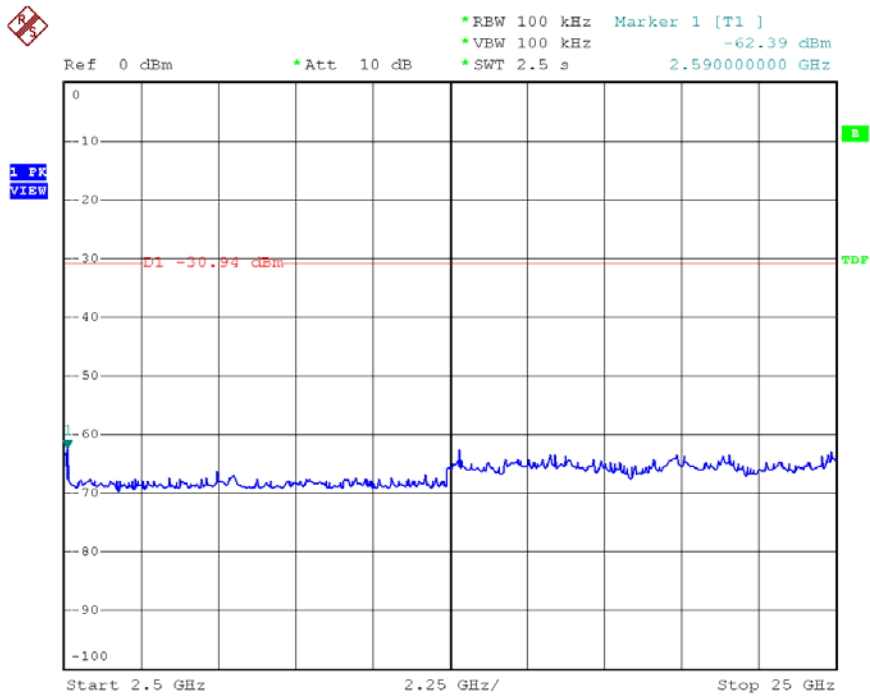

Date: 26.MAY.2008 15:44:14

Modulation Standard: 802.11n, HT20 (130Mbps), ANT-R
 Channel: 01

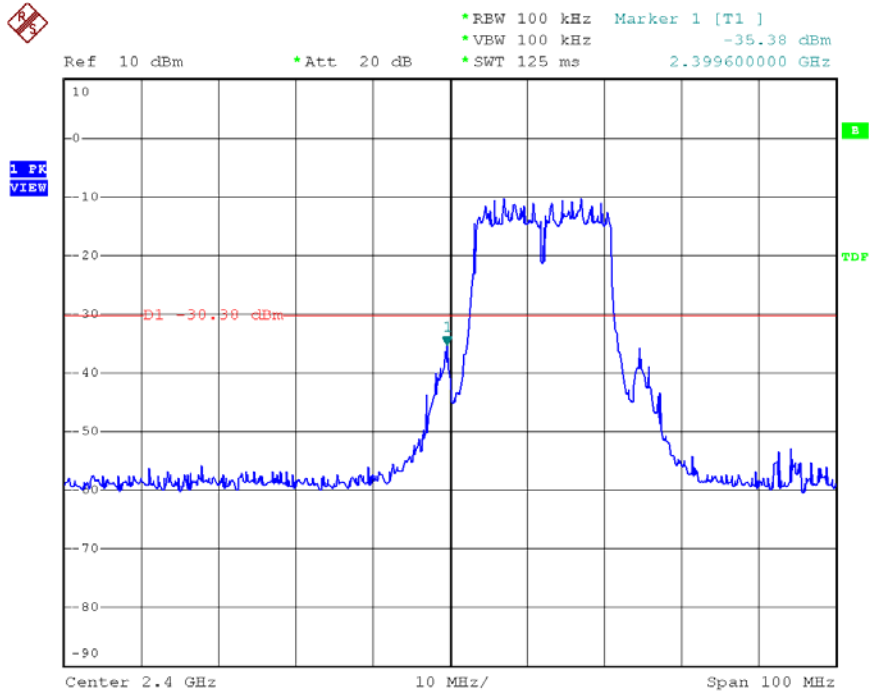

Date: 26.MAY.2008 15:33:09

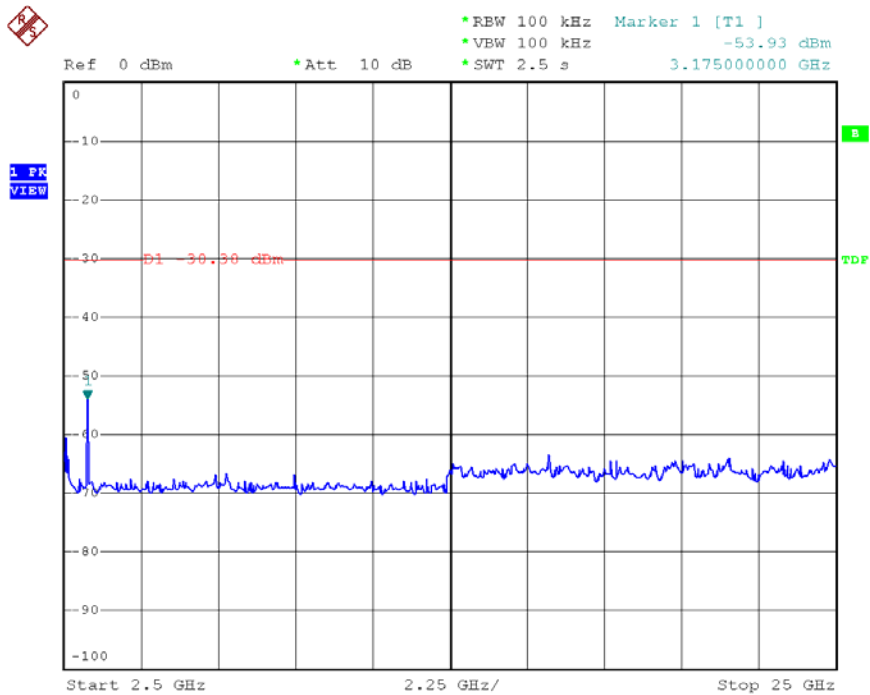

Date: 26.MAY.2008 15:33:39

Modulation Standard: 802.11n, HT20 (130Mbps), ANT-R
 Channel: 11

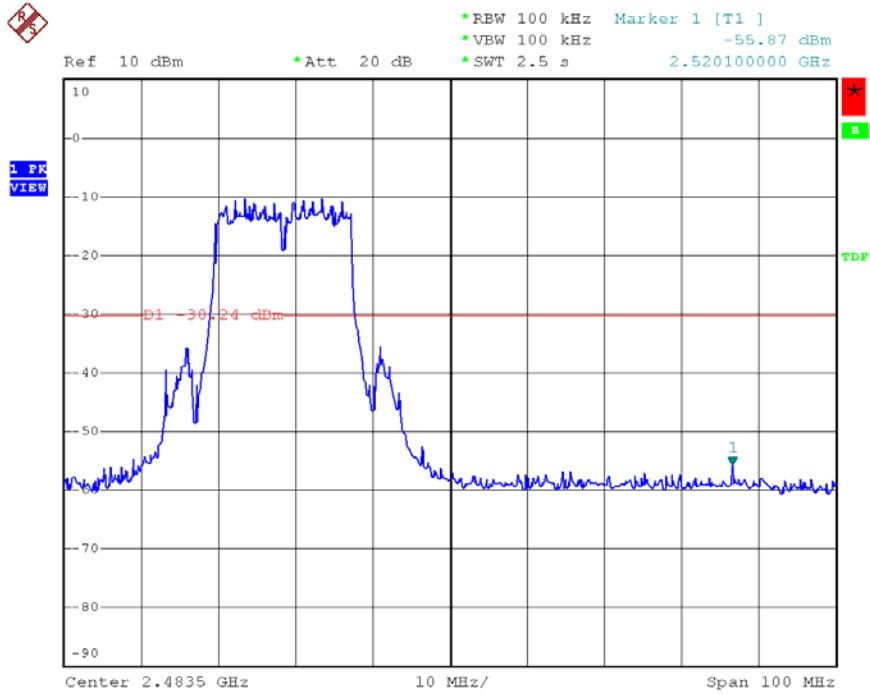

Date: 26.MAY.2008 15:34:30

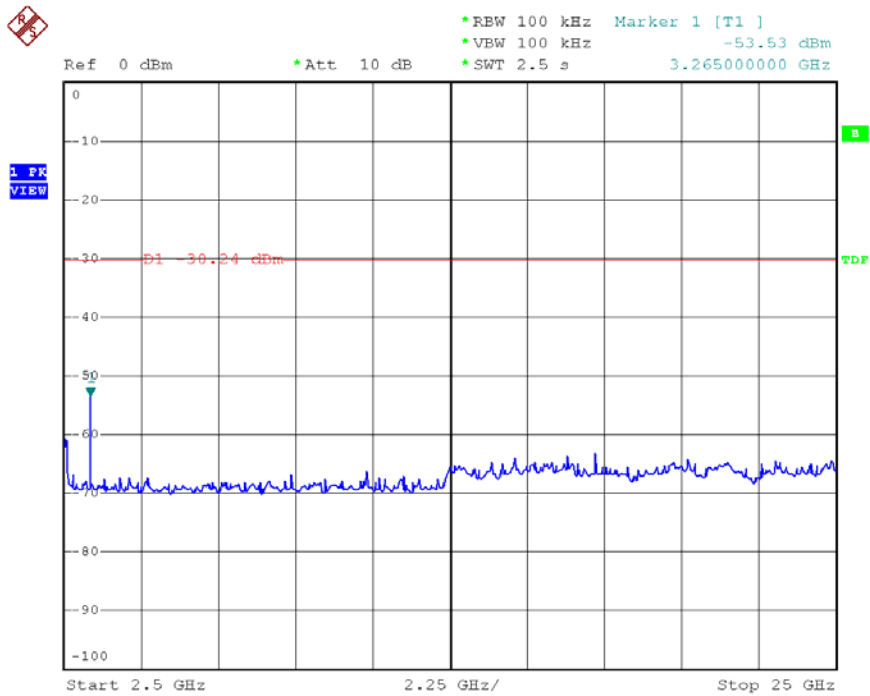

Date: 26.MAY.2008 15:35:33

Modulation Standard: 802.11n, HT40 (270Mbps), ANT-L
 Channel: 03

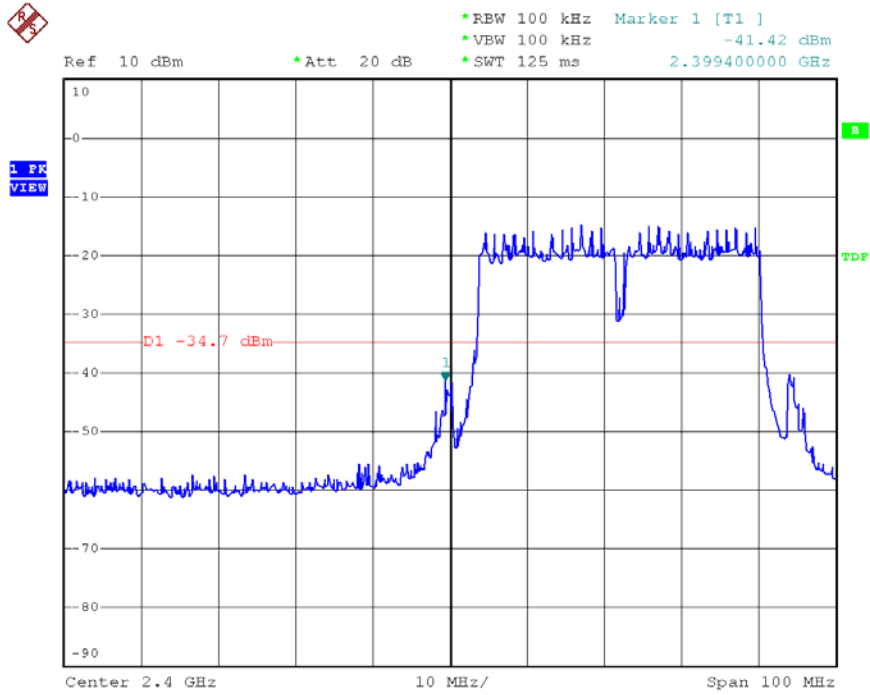

Date: 26.MAY.2008 19:26:16

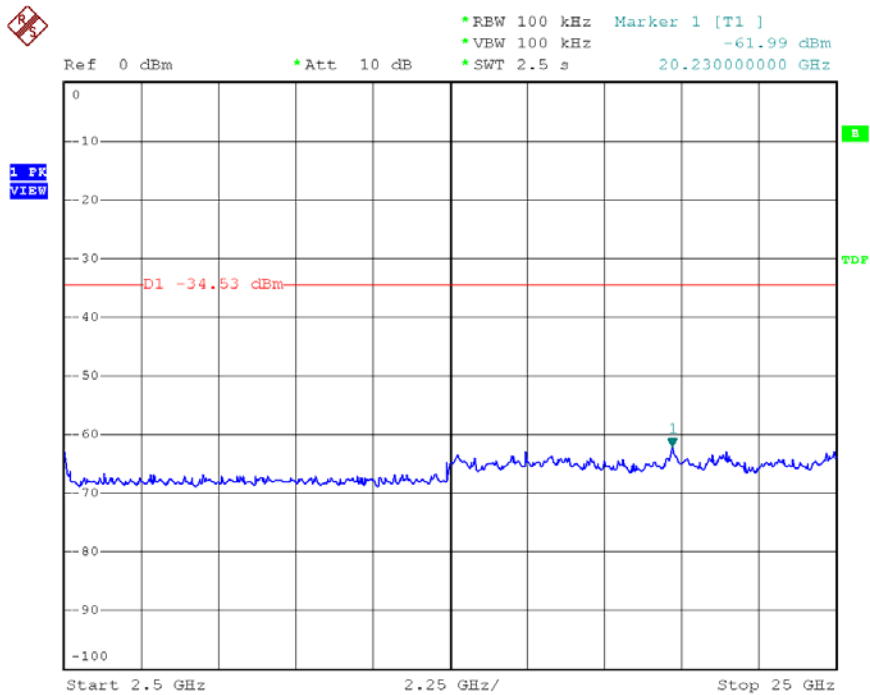

Date: 26.MAY.2008 19:30:57

Modulation Standard: 802.11n, HT40 (270Mbps), ANT-L
 Channel: 09

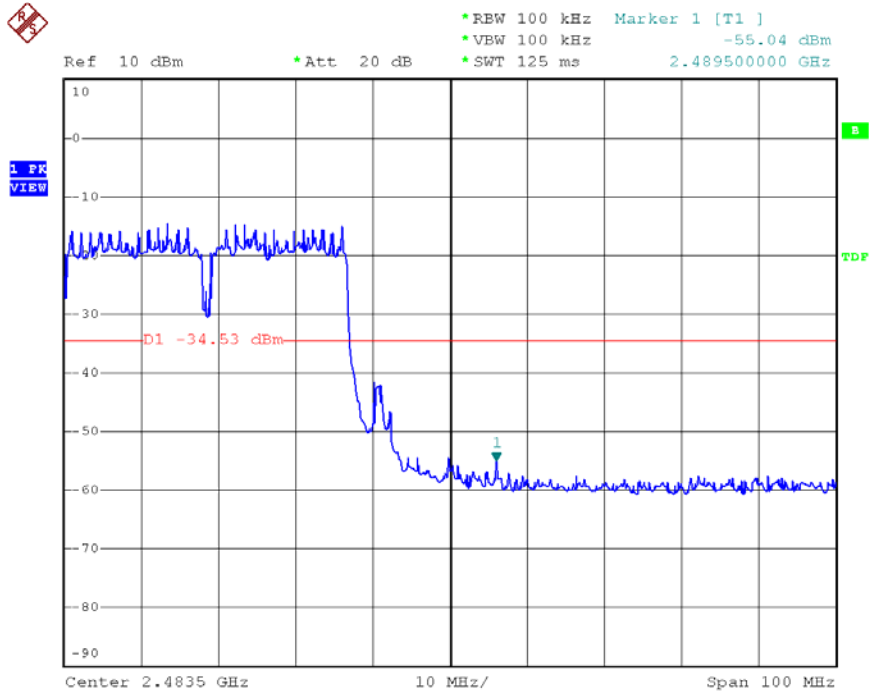

Date: 26.MAY.2008 19:28:48

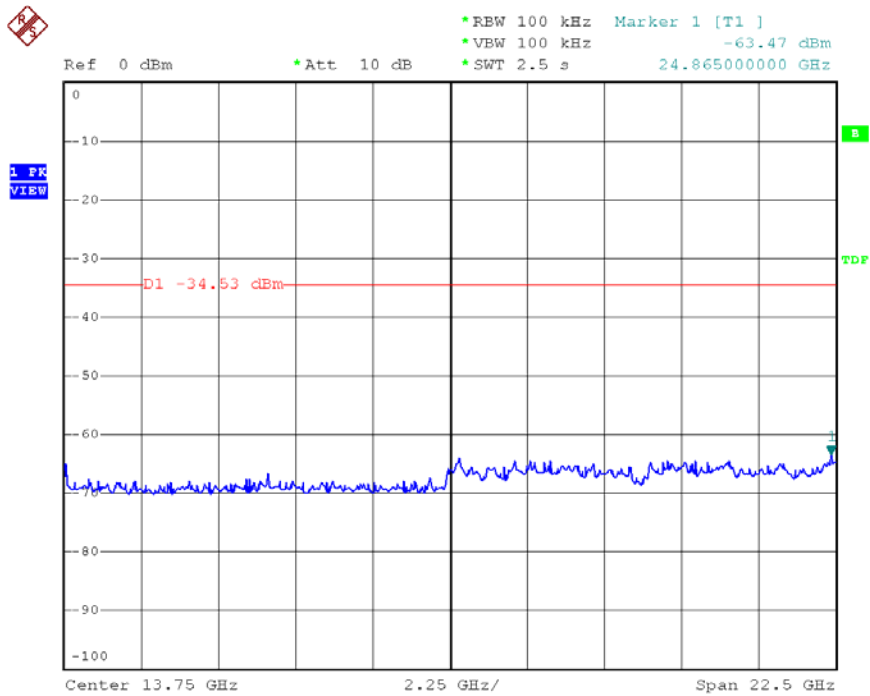

Date: 26.MAY.2008 19:34:53

Modulation Standard: 802.11n, HT40 (270Mbps), ANT-R
 Channel: 03

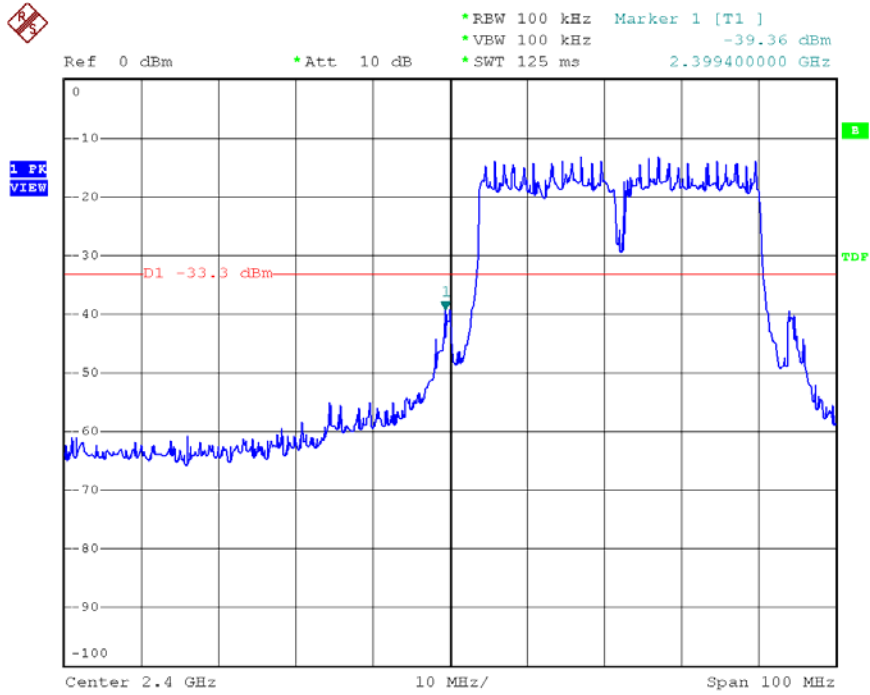

Date: 26.MAY.2008 19:23:52

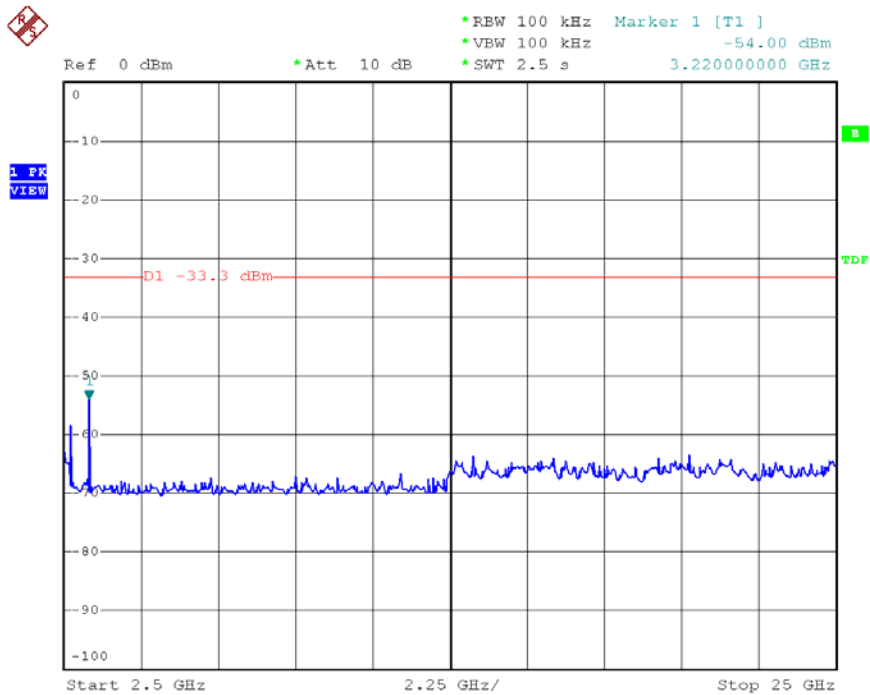

Date: 26.MAY.2008 19:24:25

Modulation Standard: 802.11n, HT40 (270Mbps), ANT-R
 Channel: 09

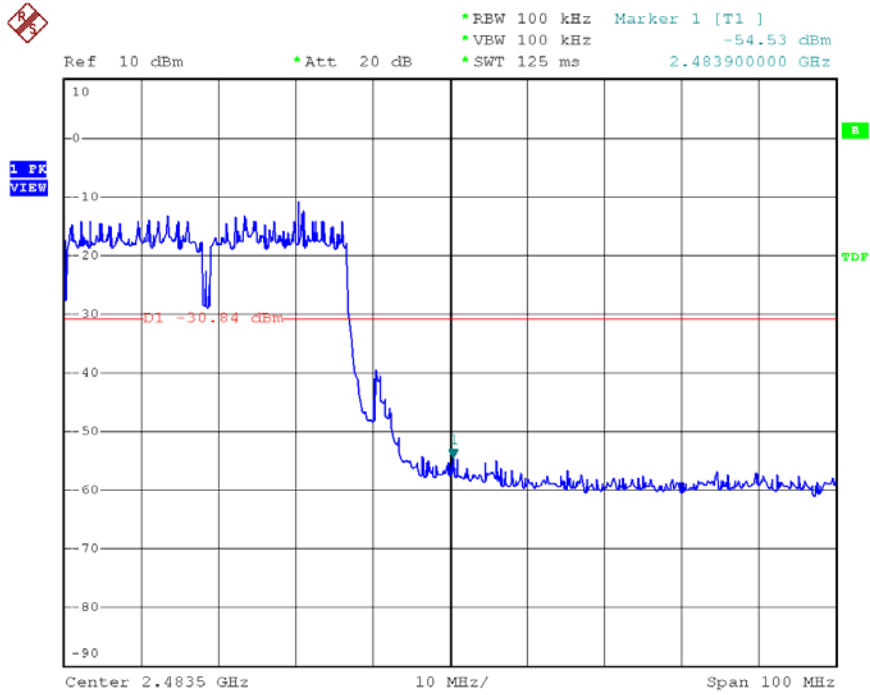

Date: 26.MAY.2008 19:32:48

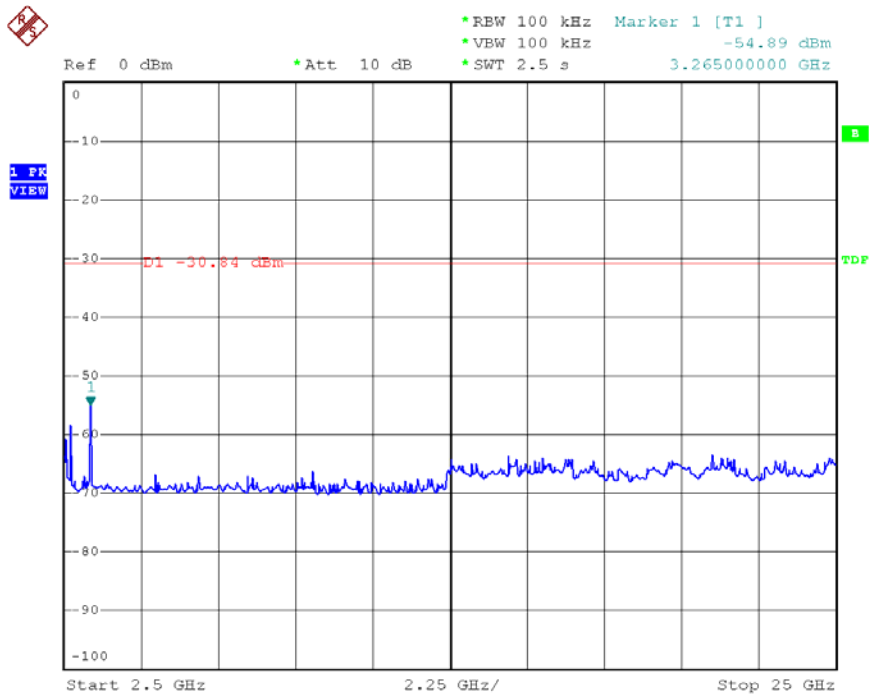

Date: 26.MAY.2008 19:33:14

8.6 Restrict band emission Measurement Data

Test Mode 1:

Modulation Standard: IEEE 802.11b (11Mbps)

Test Date: May. 27, 2008 Temperature: 25 Humidity: 65% Atmospheric pressure: 1020 hPa

a) Channel 1

Frequency (MHz)	Ant-Pol H/V	Meter Reading	Corrected Factor	Result (dBuV/m)	Remark	Limit@3m (dBuV/m)		Margin (dB)	Table (Deg.)	Ant High (m)
						Peak	Ave.			
2379.97	H	56.14	-3.35	52.79	Peak	74	54	-21.21	241	1.0
2369.36	H	43.81	-3.37	40.44	Ave	74	54	-13.56	241	1.0
2389.76	V	58.01	-3.30	54.71	Peak	74	54	-19.29	198	1.0
2368.85	V	45.57	-3.37	42.20	Ave	74	54	-11.80	198	1.0

b) Channel 11

Frequency (MHz)	Ant-Pol H/V	Meter Reading	Corrected Factor	Result (dBuV/m)	Remark	Limit@3m (dBuV/m)		Margin (dB)	Table (Deg.)	Ant High (m)
						Peak	Ave.			
2484.69	H	55.57	-2.96	52.61	Peak	74	54	-21.39	258	1.0
2485.33	H	42.95	-2.95	40.00	Ave	74	54	-14.00	258	1.0
2483.62	V	57.28	-2.96	54.32	Peak	74	54	-19.68	144	1.0
2483.55	V	45.20	-2.96	42.25	Ave	74	54	-11.75	144	1.0

Modulation Standard: 802.11g (54Mbps)

Test Date: May. 16, 2008 Temperature: 25 Humidity: 65% Atmospheric pressure: 1020 hPa

a) Channel 1

Frequency (MHz)	Ant-Pol H/V	Meter Reading	Corrected Factor	Result (dBuV/m)	Remark	Limit@3m (dBuV/m)		Margin (dB)	Table (Deg.)	Ant High (m)
						Peak	Ave.			
2365.49	H	53.22	-3.38	49.84	Peak	74	54	-24.16	241	1.0
2319.89	H	41.88	-3.55	38.33	Ave	74	54	-15.67	241	1.0
2389.76	V	56.08	-3.30	52.79	Peak	74	54	-21.21	198	1.0
2319.89	V	43.54	-3.55	39.99	Ave	74	54	-14.01	198	1.0

b) Channel 11

Frequency (MHz)	Ant-Pol H/V	Meter Reading	Corrected Factor	Result (dBuV/m)	Remark	Limit@3m (dBuV/m)		Margin (dB)	Table (Deg.)	Ant High (m)
						Peak	Ave.			
2484.19	H	54.28	-2.96	51.33	Peak	74	54	-22.67	258	1.0
2484.19	H	42.33	-2.96	39.37	Ave	74	54	-14.63	258	1.0
2484.95	V	56.33	-2.95	53.38	Peak	74	54	-20.62	144	1.0
2483.74	V	44.33	-2.96	41.37	Ave	74	54	-12.63	144	1.0

Notes:

1. Result = Meter Reading + Factor
2. Factor = Antenna Factor + Cable Loss – Amplifier
3. The resolution bandwidth of test receiver/spectrum analyzer is 1 MHz and video bandwidth is 3 MHz for Peak detection at frequency above 1GHz.
4. The resolution bandwidth of test receiver/spectrum analyzer is 1MHz and video bandwidth is 10Hz for Average detection at frequency above 1GHz

Modulation Standard: IEEE 802.11n, HT20 (130Mbps)

Test Date: May. 27, 2008 Temperature: 25 Humidity: 65% Atmospheric pressure: 1020 hPa

a) Channel 1

Frequency (MHz)	Ant-Pol H/V	Meter Reading	Corrected Factor	Result (dBuV/m)	Remark	Limit@3m (dBuV/m)		Margin (dB)	Table (Deg.)	Ant High (m)
						Peak	Ave.			
2328.05	H	53.78	-3.52	50.27	Peak	74	54	-23.73	241	1.0
2319.89	H	41.57	-3.55	38.02	Ave	74	54	-15.98	241	1.0
2388.95	V	54.14	-3.30	50.84	Peak	74	54	-23.16	198	1.0
2389.76	V	41.33	-3.30	38.03	Ave	74	54	-15.97	198	1.0

b) Channel 11

Frequency (MHz)	Ant-Pol H/V	Meter Reading	Corrected Factor	Result (dBuV/m)	Remark	Limit@3m (dBuV/m)		Margin (dB)	Table (Deg.)	Ant High (m)
						Peak	Ave.			
2483.55	H	54.89	-2.96	51.93	Peak	74	54	-22.07	258	1.0
2483.62	H	42.91	-2.96	39.95	Ave	74	54	-14.05	258	1.0
2483.81	V	55.30	-2.96	52.34	Peak	74	54	-21.66	144	1.0
2484.12	V	43.34	-2.96	40.38	Ave	74	54	-13.62	144	1.0

Modulation Standard: 802.11n, HT40 (270Mbps)

Test Date: May. 27, 2008 Temperature: 25 Humidity: 65% Atmospheric pressure: 1020 hPa

a) Channel 3

Frequency (MHz)	Ant-Pol H/V	Meter Reading	Corrected Factor	Result (dBuV/m)	Remark	Limit@3m (dBuV/m)		Margin (dB)	Table (Deg.)	Ant High (m)
						Peak	Ave.			
2386.19	H	54.05	-3.31	50.74	Peak	74	54	-23.26	241	1.0
2389.97	H	41.80	-3.30	38.51	Ave	74	54	-15.49	241	1.0
2387.93	V	55.78	-3.30	52.48	Peak	74	54	-21.52	198	1.0
2385.38	V	43.21	-3.31	39.90	Ave	74	54	-14.10	198	1.0

b) Channel 9

Frequency (MHz)	Ant-Pol H/V	Meter Reading	Corrected Factor	Result (dBuV/m)	Remark	Limit@3m (dBuV/m)		Margin (dB)	Table (Deg.)	Ant High (m)
						Peak	Ave.			
2485.71	H	52.69	-2.95	49.74	Peak	74	54	-24.26	148	1.22
2485.83	H	40.34	-2.95	37.39	Ave	74	54	-16.61	148	1.22
2483.62	V	57.38	-2.96	54.42	Peak	74	54	-19.58	198	1.00
2486.97	V	44.63	-2.95	41.68	Ave	74	54	-12.32	198	1.00

Notes:

1. Result = Meter Reading + Factor
2. Factor = Antenna Factor + Cable Loss – Amplifier
3. The resolution bandwidth of test receiver/spectrum analyzer is 1 MHz and video bandwidth is 3 MHz for Peak detection at frequency above 1GHz.
4. The resolution bandwidth of test receiver/spectrum analyzer is 1MHz and video bandwidth is 10Hz for Average detection at frequency above 1GHz

Test Mode 2:

Modulation Standard: IEEE 802.11b (11Mbps)

Test Date: May. 27, 2008 Temperature: 25 Humidity: 65% Atmospheric pressure: 1020 hPa

a) Channel 1

Frequency (MHz)	Ant-Pol H/V	Meter Reading	Corrected Factor	Result (dBuV/m)	Remark	Limit@3m (dBuV/m)		Margin (dB)	Table (Deg.)	Ant High (m)
						Peak	Ave.			
2379.97	H	56.09	-3.35	52.74	Peak	74	54	-21.26	241	1.0
2369.36	H	43.70	-3.37	40.33	Ave	74	54	-13.67	241	1.0
2389.76	V	58.00	-3.30	54.70	Peak	74	54	-19.30	198	1.0
2368.85	V	45.49	-3.37	42.12	Ave	74	54	-11.88	198	1.0

b) Channel 11

Frequency (MHz)	Ant-Pol H/V	Meter Reading	Corrected Factor	Result (dBuV/m)	Remark	Limit@3m (dBuV/m)		Margin (dB)	Table (Deg.)	Ant High (m)
						Peak	Ave.			
2484.69	H	55.53	-2.96	52.57	Peak	74	54	-21.43	258	1.0
2485.33	H	42.84	-2.95	39.89	Ave	74	54	-14.11	258	1.0
2483.62	V	57.11	-2.96	54.15	Peak	74	54	-19.85	144	1.0
2483.55	V	45.19	-2.96	42.23	Ave	74	54	-11.77	144	1.0

Modulation Standard: 802.11g (54Mbps)

Test Date: May. 16, 2008 Temperature: 25 Humidity: 65% Atmospheric pressure: 1020 hPa

a) Channel 1

Frequency (MHz)	Ant-Pol H/V	Meter Reading	Corrected Factor	Result (dBuV/m)	Remark	Limit@3m (dBuV/m)		Margin (dB)	Table (Deg.)	Ant High (m)
						Peak	Ave.			
2365.49	H	53.16	-3.38	49.78	Peak	74	54	-24.22	241	1.0
2319.89	H	41.75	-3.55	38.20	Ave	74	54	-15.80	241	1.0
2389.76	V	56.01	-3.30	52.46	Peak	74	54	-21.54	198	1.0
2319.89	V	43.50	-3.55	39.95	Ave	74	54	-14.05	198	1.0

b) Channel 11

Frequency (MHz)	Ant-Pol H/V	Meter Reading	Corrected Factor	Result (dBuV/m)	Remark	Limit@3m (dBuV/m)		Margin (dB)	Table (Deg.)	Ant High (m)
						Peak	Ave.			
2484.19	H	54.13	-2.96	51.17	Peak	74	54	-22.83	258	1.0
2484.19	H	42.26	-2.96	39.30	Ave	74	54	-14.70	258	1.0
2484.95	V	56.24	-2.95	53.29	Peak	74	54	-20.71	144	1.0
2483.74	V	44.29	-2.96	41.33	Ave	74	54	-12.67	144	1.0

Notes:

1. Result = Meter Reading + Factor
2. Factor = Antenna Factor + Cable Loss – Amplifier
3. The resolution bandwidth of test receiver/spectrum analyzer is 1 MHz and video bandwidth is 3 MHz for Peak detection at frequency above 1GHz.
4. The resolution bandwidth of test receiver/spectrum analyzer is 1MHz and video bandwidth is 10Hz for Average detection at frequency above 1GHz

Modulation Standard: IEEE 802.11n, HT20 (130Mbps)

Test Date: May. 27, 2008 Temperature: 25 Humidity: 65% Atmospheric pressure: 1020 hPa

a) Channel 1

Frequency (MHz)	Ant-Pol H/V	Meter Reading	Corrected Factor	Result (dBuV/m)	Remark	Limit@3m (dBuV/m)		Margin (dB)	Table (Deg.)	Ant High (m)
						Peak	Ave.			
2328.05	H	53.66	-3.52	50.14	Peak	74	54	-23.86	241	1.0
2319.89	H	41.49	-3.55	37.94	Ave	74	54	-16.06	241	1.0
2388.95	V	54.16	-3.30	50.86	Peak	74	54	-23.14	198	1.0
2389.76	V	41.30	-3.30	38.00	Ave	74	54	-16.00	198	1.0

b) Channel 11

Frequency (MHz)	Ant-Pol H/V	Meter Reading	Corrected Factor	Result (dBuV/m)	Remark	Limit@3m (dBuV/m)		Margin (dB)	Table (Deg.)	Ant High (m)
						Peak	Ave.			
2483.55	H	54.66	-2.96	51.70	Peak	74	54	-22.30	258	1.0
2483.62	H	42.85	-2.96	39.89	Ave	74	54	-14.11	258	1.0
2483.81	V	55.11	-2.96	52.15	Peak	74	54	-21.85	144	1.0
2484.12	V	43.27	-2.96	40.31	Ave	74	54	-13.69	144	1.0

Modulation Standard: 802.11n, HT40 (270Mbps)

Test Date: May. 27, 2008 Temperature: 25 Humidity: 65% Atmospheric pressure: 1020 hPa

a) Channel 3

Frequency (MHz)	Ant-Pol H/V	Meter Reading	Corrected Factor	Result (dBuV/m)	Remark	Limit@3m (dBuV/m)		Margin (dB)	Table (Deg.)	Ant High (m)
						Peak	Ave.			
2386.19	H	54.05	-3.31	50.74	Peak	74	54	-23.26	241	1.0
2389.97	H	41.77	-3.30	38.47	Ave	74	54	-15.53	241	1.0
2387.93	V	55.72	-3.30	52.42	Peak	74	54	-21.58	198	1.0
2385.38	V	43.20	-3.31	39.89	Ave	74	54	-14.11	198	1.0

b) Channel 9

Frequency (MHz)	Ant-Pol H/V	Meter Reading	Corrected Factor	Result (dBuV/m)	Remark	Limit@3m (dBuV/m)		Margin (dB)	Table (Deg.)	Ant High (m)
						Peak	Ave.			
2485.71	H	52.72	-2.95	49.77	Peak	74	54	-24.23	148	1.22
2485.83	H	40.41	-2.95	37.46	Ave	74	54	-16.54	148	1.22
2483.62	V	57.35	-2.96	54.39	Peak	74	54	-19.61	198	1.00
2486.97	V	44.77	-2.95	41.82	Ave	74	54	-12.18	198	1.00

Notes:

1. Result = Meter Reading + Factor
2. Factor = Antenna Factor + Cable Loss – Amplifier
3. The resolution bandwidth of test receiver/spectrum analyzer is 1 MHz and video bandwidth is 3 MHz for Peak detection at frequency above 1GHz.
4. The resolution bandwidth of test receiver/spectrum analyzer is 1MHz and video bandwidth is 10Hz for Average detection at frequency above 1GHz

Test Mode 3:

Modulation Standard: IEEE 802.11b (11Mbps)

Test Date: May. 27, 2008 Temperature: 25 Humidity: 65% Atmospheric pressure: 1020 hPa

a) Channel 1

Frequency (MHz)	Ant-Pol H/V	Meter Reading	Corrected Factor	Result (dBuV/m)	Remark	Limit@3m (dBuV/m)		Margin (dB)	Table (Deg.)	Ant High (m)
						Peak	Ave.			
2379.97	H	56.22	-3.35	52.87	Peak	74	54	-21.13	241	1.0
2369.36	H	43.62	-3.37	40.25	Ave	74	54	-13.75	241	1.0
2389.76	V	58.19	-3.30	54.89	Peak	74	54	-19.11	198	1.0
2368.85	V	45.63	-3.37	42.26	Ave	74	54	-11.74	198	1.0

b) Channel 11

Frequency (MHz)	Ant-Pol H/V	Meter Reading	Corrected Factor	Result (dBuV/m)	Remark	Limit@3m (dBuV/m)		Margin (dB)	Table (Deg.)	Ant High (m)
						Peak	Ave.			
2484.69	H	55.77	-2.96	52.81	Peak	74	54	-21.19	258	1.0
2485.33	H	43.11	-2.95	40.16	Ave	74	54	-13.84	258	1.0
2483.62	V	57.29	-2.96	54.33	Peak	74	54	-19.67	144	1.0
2483.55	V	45.25	-2.96	42.29	Ave	74	54	-11.71	144	1.0

Modulation Standard: 802.11g (54Mbps)

Test Date: May. 16, 2008 Temperature: 25 Humidity: 65% Atmospheric pressure: 1020 hPa

a) Channel 1

Frequency (MHz)	Ant-Pol H/V	Meter Reading	Corrected Factor	Result (dBuV/m)	Remark	Limit@3m (dBuV/m)		Margin (dB)	Table (Deg.)	Ant High (m)
						Peak	Ave.			
2365.49	H	53.43	-3.38	50.05	Peak	74	54	-23.95	241	1.0
2319.89	H	41.79	-3.55	38.24	Ave	74	54	-15.76	241	1.0
2389.76	V	56.21	-3.30	52.91	Peak	74	54	-21.09	198	1.0
2319.89	V	43.66	-3.55	40.11	Ave	74	54	-13.89	198	1.0

b) Channel 11

Frequency (MHz)	Ant-Pol H/V	Meter Reading	Corrected Factor	Result (dBuV/m)	Remark	Limit@3m (dBuV/m)		Margin (dB)	Table (Deg.)	Ant High (m)
						Peak	Ave.			
2484.19	H	54.35	-2.96	51.39	Peak	74	54	-22.61	258	1.0
2484.19	H	42.41	-2.96	39.45	Ave	74	54	-14.55	258	1.0
2484.95	V	56.22	-2.95	53.26	Peak	74	54	-20.74	144	1.0
2483.74	V	44.49	-2.96	41.53	Ave	74	54	-12.47	144	1.0

Notes:

1. Result = Meter Reading + Factor
2. Factor = Antenna Factor + Cable Loss – Amplifier
3. The resolution bandwidth of test receiver/spectrum analyzer is 1 MHz and video bandwidth is 3 MHz for Peak detection at frequency above 1GHz.
4. The resolution bandwidth of test receiver/spectrum analyzer is 1MHz and video bandwidth is 10Hz for Average detection at frequency above 1GHz

Modulation Standard: IEEE 802.11n, HT20 (130Mbps)

Test Date: May. 27, 2008 Temperature: 25 Humidity: 65% Atmospheric pressure: 1020 hPa

a) Channel 1

Frequency (MHz)	Ant-Pol H/V	Meter Reading	Corrected Factor	Result (dBuV/m)	Remark	Limit@3m (dBuV/m)		Margin (dB)	Table (Deg.)	Ant High (m)
						Peak	Ave.			
2328.05	H	53.84	-3.52	50.32	Peak	74	54	-23.68	241	1.0
2319.89	H	41.92	-3.55	38.37	Ave	74	54	-15.63	241	1.0
2388.95	V	54.25	-3.30	50.95	Peak	74	54	-23.05	198	1.0
2389.76	V	41.48	-3.30	38.18	Ave	74	54	-15.82	198	1.0

b) Channel 11

Frequency (MHz)	Ant-Pol H/V	Meter Reading	Corrected Factor	Result (dBuV/m)	Remark	Limit@3m (dBuV/m)		Margin (dB)	Table (Deg.)	Ant High (m)
						Peak	Ave.			
2483.55	H	54.86	-2.96	51.90	Peak	74	54	-22.10	258	1.0
2483.62	H	42.95	-2.96	39.99	Ave	74	54	-14.01	258	1.0
2483.81	V	55.41	-2.96	52.45	Peak	74	54	-21.55	144	1.0
2484.12	V	43.42	-2.96	40.46	Ave	74	54	-13.54	144	1.0

Modulation Standard: 802.11n, HT40 (270Mbps)

Test Date: May. 27, 2008 Temperature: 25 Humidity: 65% Atmospheric pressure: 1020 hPa

a) Channel 3

Frequency (MHz)	Ant-Pol H/V	Meter Reading	Corrected Factor	Result (dBuV/m)	Remark	Limit@3m (dBuV/m)		Margin (dB)	Table (Deg.)	Ant High (m)
						Peak	Ave.			
2386.19	H	54.17	-3.31	50.86	Peak	74	54	-23.14	241	1.0
2389.97	H	41.73	-3.30	38.43	Ave	74	54	-15.57	241	1.0
2387.93	V	55.82	-3.30	52.52	Peak	74	54	-21.48	198	1.0
2385.38	V	43.29	-3.31	39.98	Ave	74	54	-14.02	198	1.0

b) Channel 9

Frequency (MHz)	Ant-Pol H/V	Meter Reading	Corrected Factor	Result (dBuV/m)	Remark	Limit@3m (dBuV/m)		Margin (dB)	Table (Deg.)	Ant High (m)
						Peak	Ave.			
2485.71	H	52.74	-2.95	49.79	Peak	74	54	-24.21	148	1.22
2485.83	H	40.48	-2.95	37.53	Ave	74	54	-16.47	148	1.22
2483.62	V	57.46	-2.96	54.50	Peak	74	54	-19.50	198	1.00
2486.97	V	44.78	-2.95	41.83	Ave	74	54	-12.17	198	1.00

Notes:

1. Result = Meter Reading + Factor
2. Factor = Antenna Factor + Cable Loss – Amplifier
3. The resolution bandwidth of test receiver/spectrum analyzer is 1 MHz and video bandwidth is 3 MHz for Peak detection at frequency above 1GHz.
4. The resolution bandwidth of test receiver/spectrum analyzer is 1MHz and video bandwidth is 10Hz for Average detection at frequency above 1GHz

9. Power Spectral Density

9.1 Test Limit

The Maximum of Power Spectral Density Measurement is 8dBm.

9.2 Test Procedures

- The transmitter output was connected to spectrum analyzer.
- The spectrum analyzer's resolution bandwidth were set at 3KHz RBW and 30KHz VBW as that of the fundamental frequency. Set the sweep time=span/3KHz.
- The power spectral density was measured and recorded.
- The Sweep time is allowed to be longer than span/3KHz for a full response of the mixer in the spectrum analyzer.

9.3 Test Setup Layout :

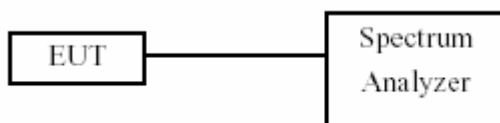

9.4 Measurement equipment

Instrument/Ancillary	Model No.	Manufacturer	Serial No.	Calibration Date	Valid Date
Spectrum Analyzer	FSP40	R&S	10047	2008/02/22	2009/02/21

9.5 Test Result and Data

- (1) Modulation Standard: IEEE 802.11b (11Mbps), ANT-L

Test Date: May. 26, 2008 Temperature: 20 Humidity: 60% Atmospheric pressure: 1008 hPa

Channel	Frequency	Maximum Power Density of 3 kHz Bandwidth (dBm)
01	2412	-18.03
06	2437	-18.43
11	2462	-18.10

- (2) Modulation Standard: IEEE 802.11g (54Mbps), ANT-L

Test Date: May. 26, 2008 Temperature: 20 Humidity: 60% Atmospheric pressure: 1008 hPa

Channel	Frequency	Maximum Power Density of 3 kHz Bandwidth (dBm)
01	2412	-19.51
06	2437	-19.66
11	2462	-20.33

- (3) Modulation Standard: IEEE 802.11b (11Mbps), ANT-R

Test Date: May. 26, 2008 Temperature: 20 Humidity: 60% Atmospheric pressure: 1008 hPa

Channel	Frequency	Maximum Power Density of 3 kHz Bandwidth (dBm)
01	2412	-14.39
06	2437	-14.28
11	2462	-13.09

- (4) Modulation Standard: IEEE 802.11g (54Mbps), ANT-R

Test Date: May. 26, 2008 Temperature: 20 Humidity: 60% Atmospheric pressure: 1008 hPa

Channel	Frequency	Maximum Power Density of 3 kHz Bandwidth (dBm)
01	2412	-20.49
06	2437	-19.49
11	2462	-20.19

(5) Modulation Standard: IEEE 802.11n, HT20 (130Mbps)

Test Date: May. 26, 2008 Temperature: 20 Humidity: 60% Atmospheric pressure: 1008 hPa

Channel	Frequency	Maximum Power Density of 3 kHz Bandwidth (dBm)		
		ANT-L	ANT-R	Total
01	2412	-20.32	-16.09	-14.70
06	2437	-19.39	-15.22	-13.81
11	2462	-21.19	-15.93	-14.80

(6) Modulation Standard: IEEE 802.11n, HT40 (270Mbps)

Test Date: May. 26, 2008 Temperature: 20 Humidity: 60% Atmospheric pressure: 1008 hPa

Channel	Frequency	Maximum Power Density of 3 kHz Bandwidth (dBm)		
		ANT-L	ANT-R	Total
03	2422	-34.92	-32.80	-30.72
06	2437	-30.70	-30.07	-27.36
09	2452	-30.86	-30.38	-27.60

Modulation Standard: 802.11b (11Mbps), ANT-L
Channel: 01

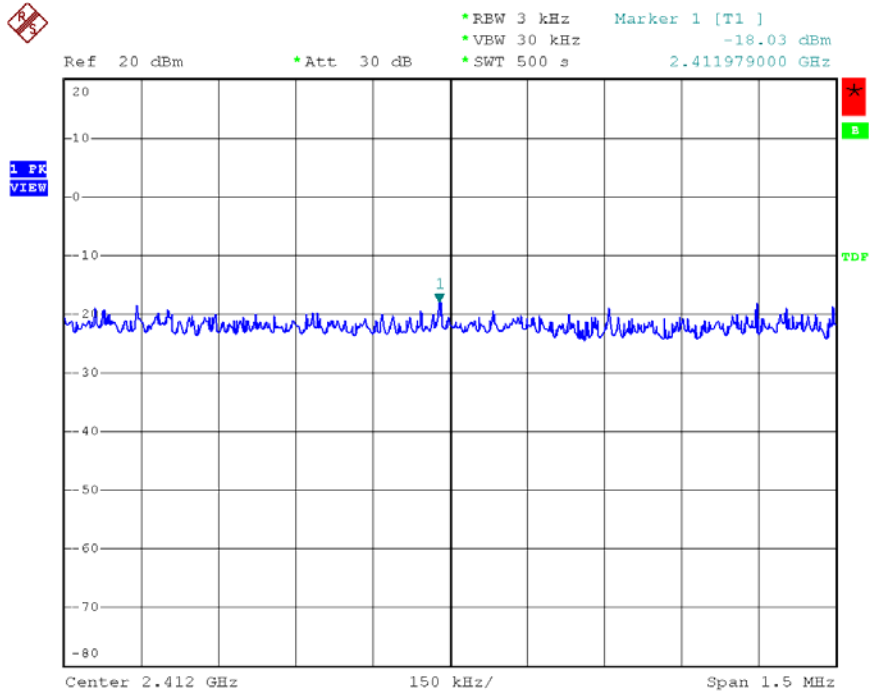

Date: 26.MAY.2008 11:48:09

Modulation Standard: 802.11b (11Mbps), ANT-L
Channel: 06

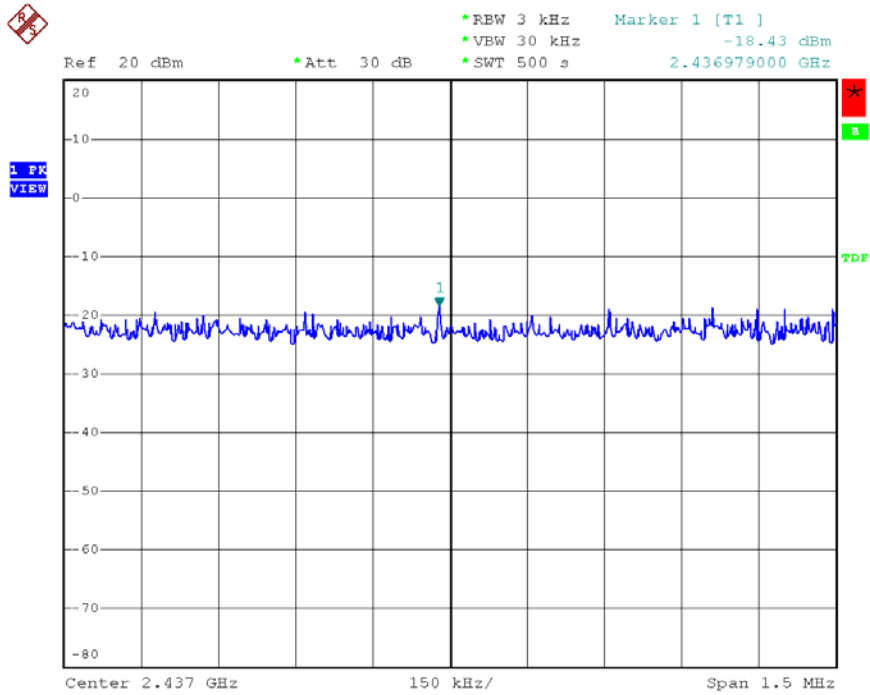

Date: 26.MAY.2008 11:54:57

Modulation Standard: 802.11b (11Mbps), ANT-L
Channel: 11

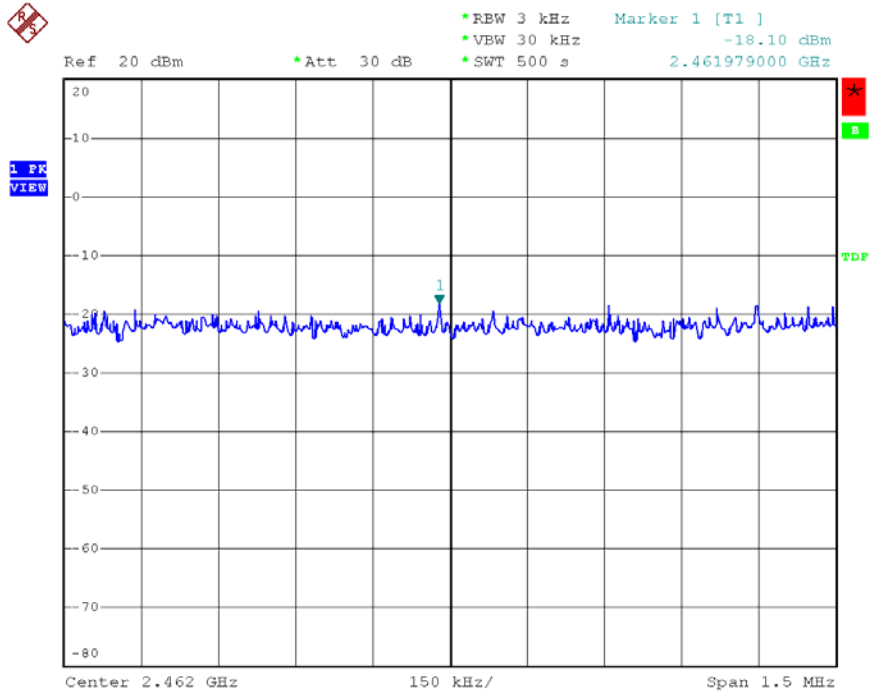

Date: 26.MAY.2008 11:56:31

Modulation Standard: 802.11g (54Mbps), ANT-L
Channel: 01

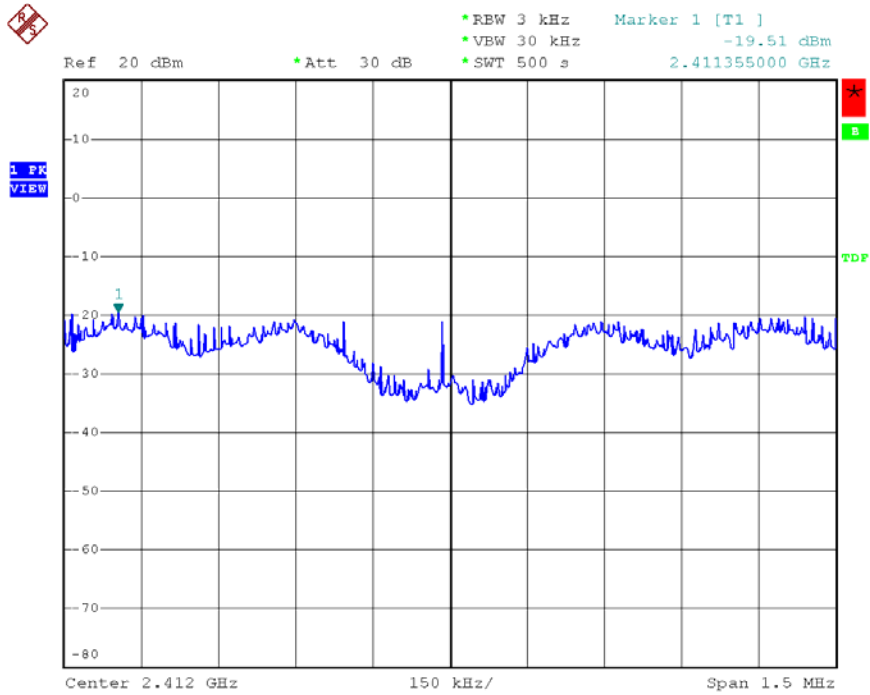

Date: 26.MAY.2008 14:04:40

Modulation Standard: 802.11g (54Mbps), ANT-L
Channel: 06

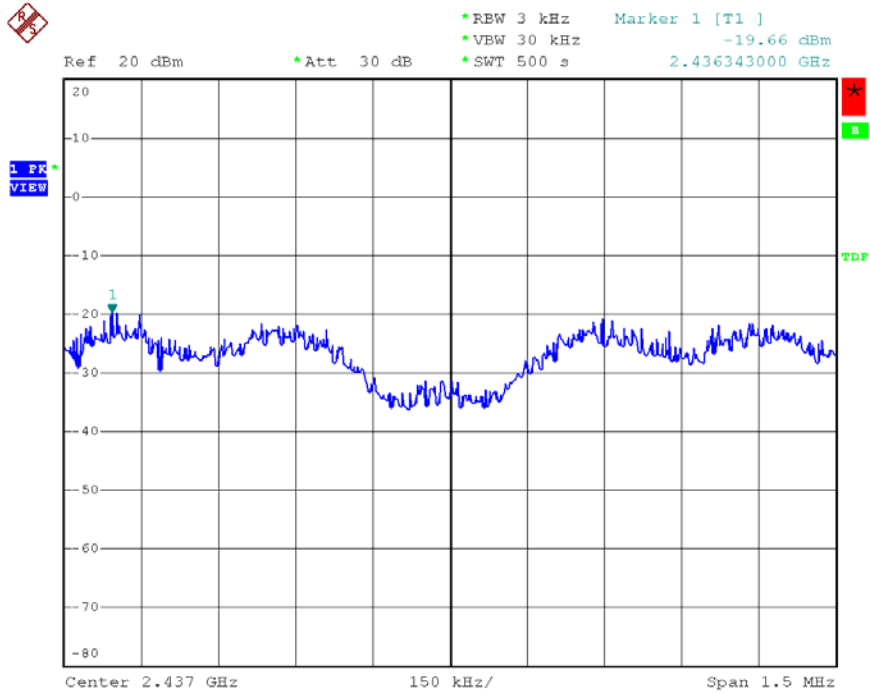

Date: 26.MAY.2008 14:06:13

Modulation Standard: 802.11g (54Mbps), ANT-L
Channel: 11

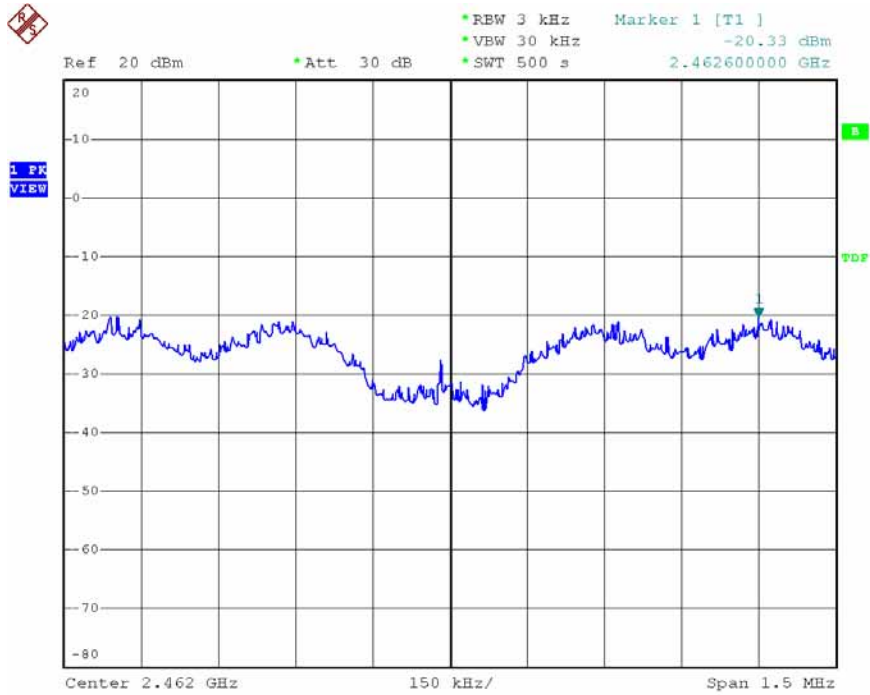

Date: 26.MAY.2008 14:07:21

Modulation Standard: 802.11b (11Mbps), ANT-R
 Channel: 01

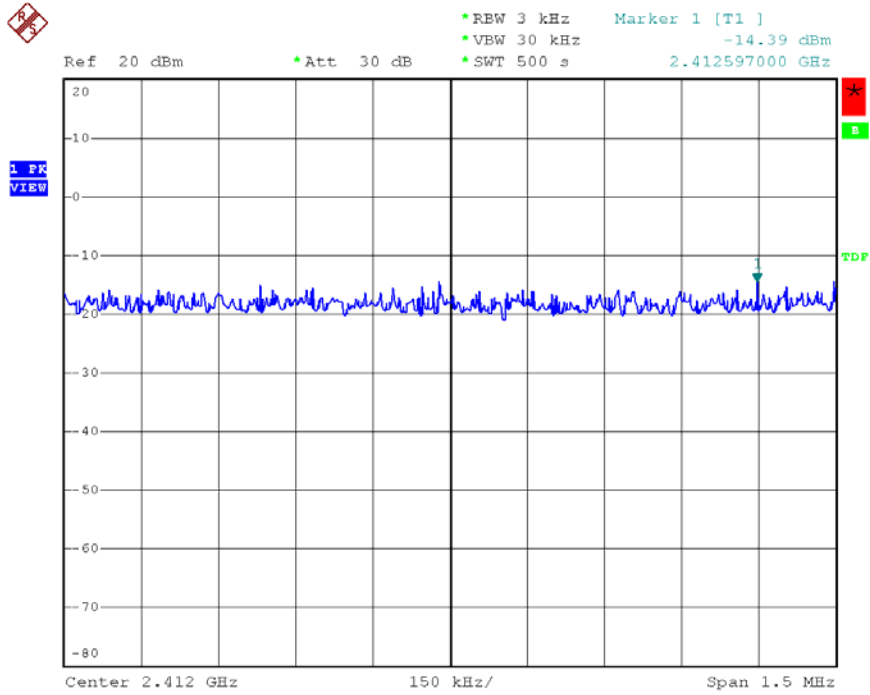

Date: 26.MAY.2008 14:55:41

Modulation Standard: 802.11b (11Mbps), ANT-R
 Channel: 06

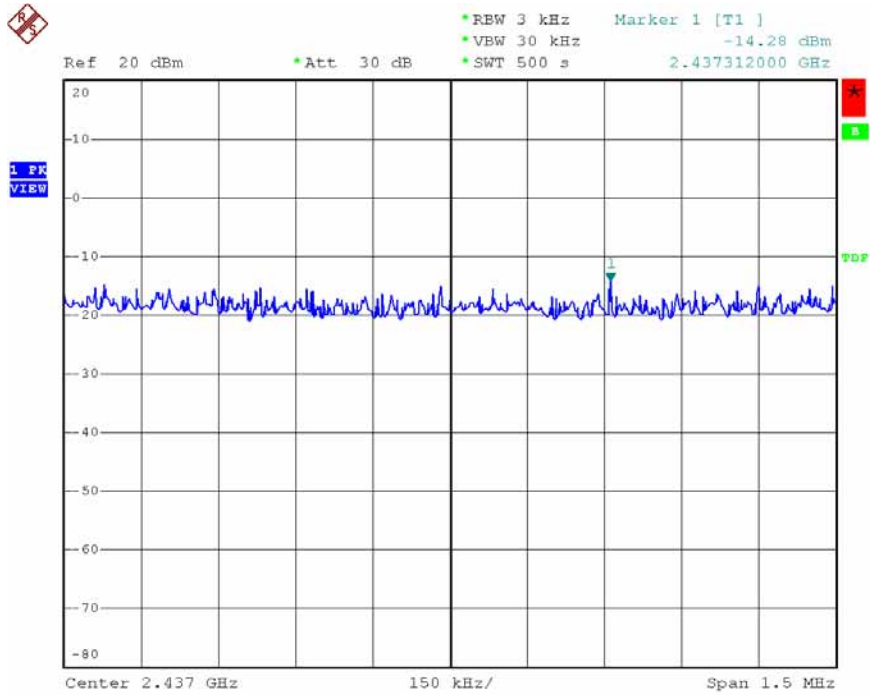

Date: 26.MAY.2008 14:56:31

Modulation Standard: 802.11b (11Mbps), ANT-R
 Channel: 11

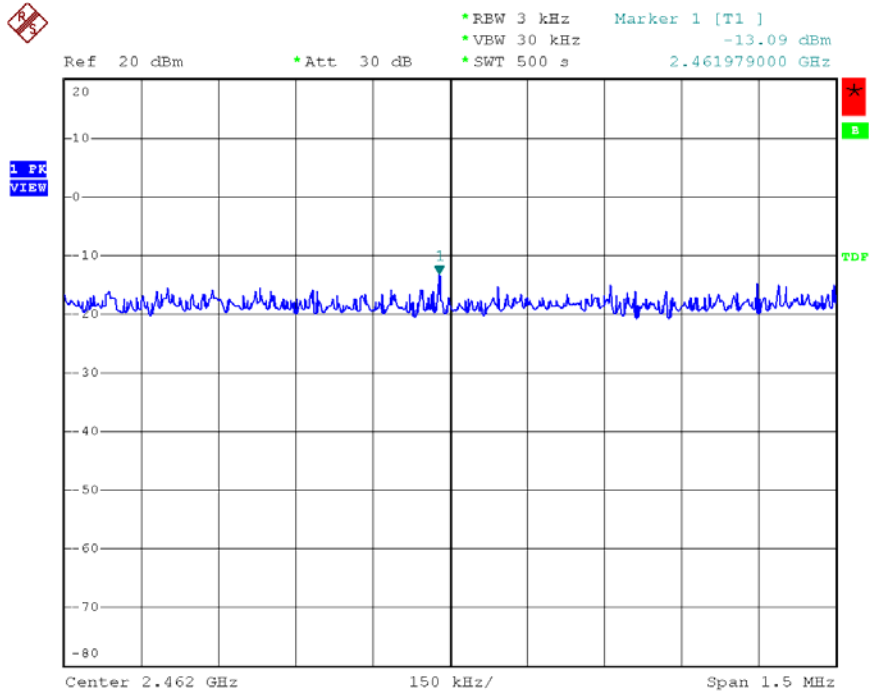

Date: 26.MAY.2008 14:57:21

Modulation Standard: 802.11g (54Mbps), ANT-R
 Channel: 01

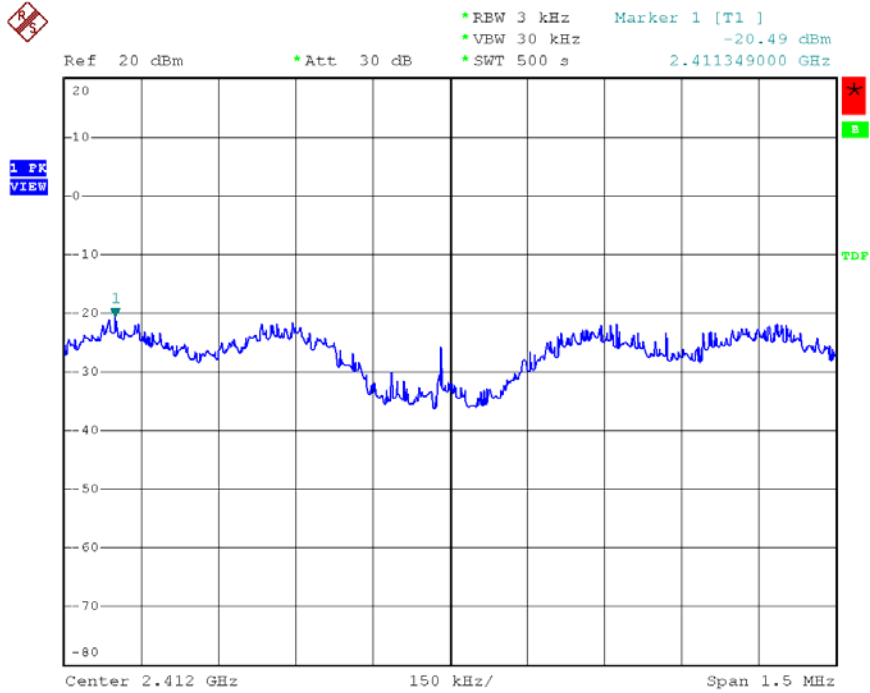

Date: 26.MAY.2008 14:52:01

Modulation Standard: 802.11g (54Mbps), ANT-R
Channel: 06

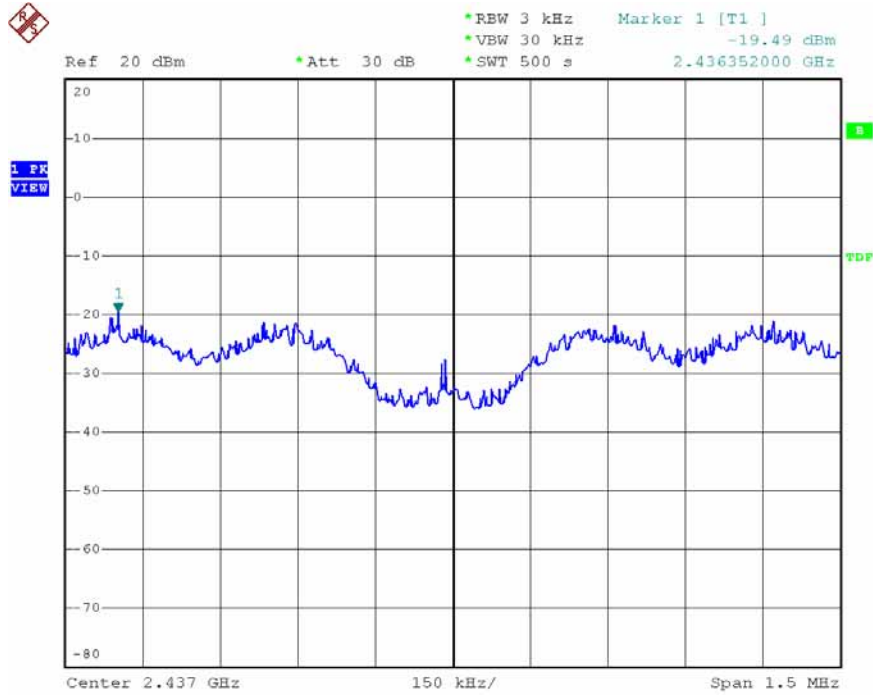

Date: 26.MAY.2008 14:53:23

Modulation Standard: 802.11g (54Mbps), ANT-R
Channel: 11

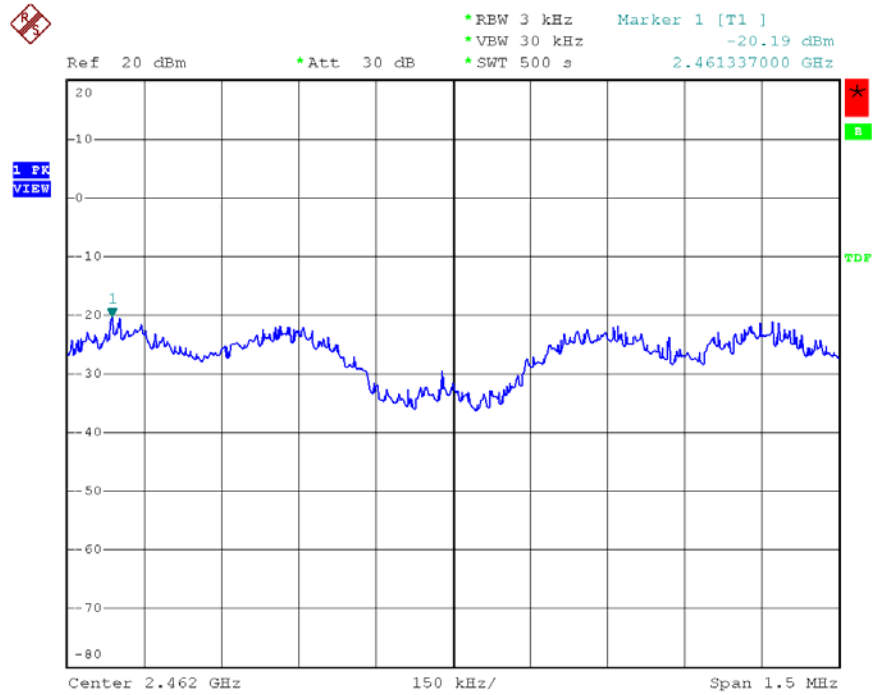

Date: 26.MAY.2008 14:54:30

Modulation Standard: 802.11n, HT20 (130Mbps), ANT-L
Channel: 01

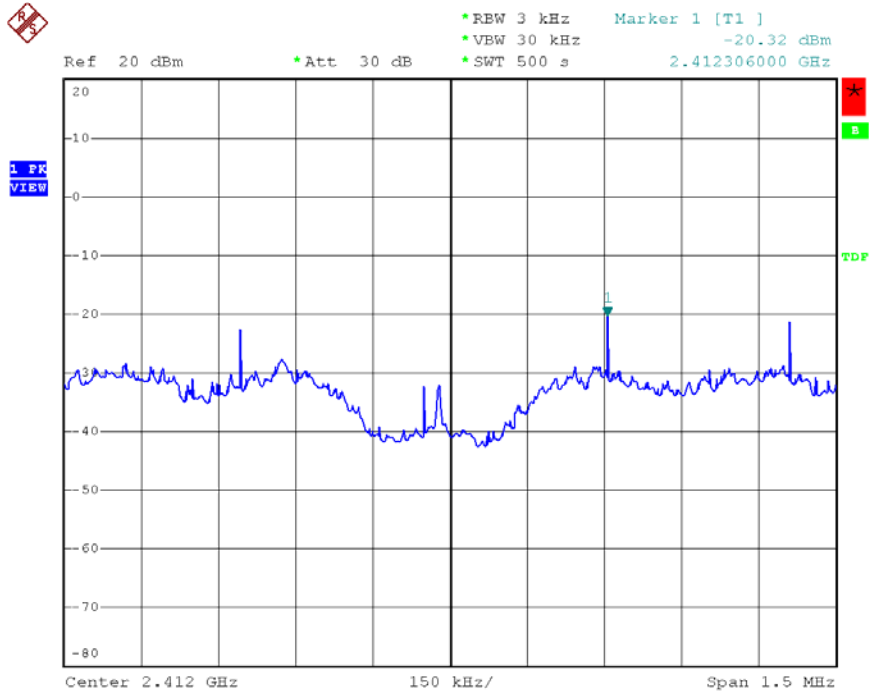

Date: 26.MAY.2008 15:54:34

Modulation Standard: 802.11n, HT20 (130Mbps), ANT-L
Channel: 06

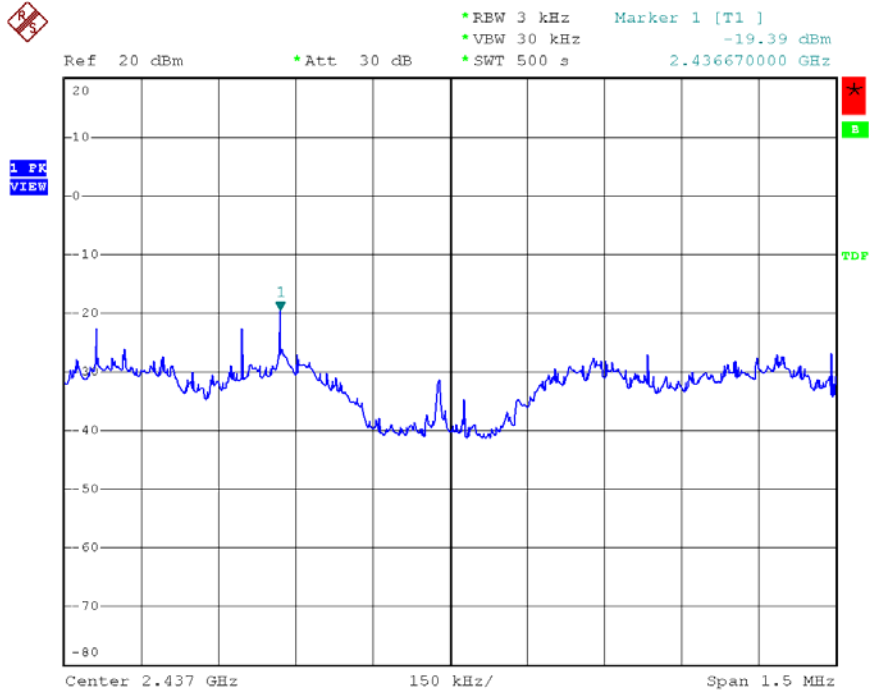

Date: 26.MAY.2008 16:08:41

Modulation Standard: 802.11n, HT20 (130Mbps), ANT-L
Channel: 11

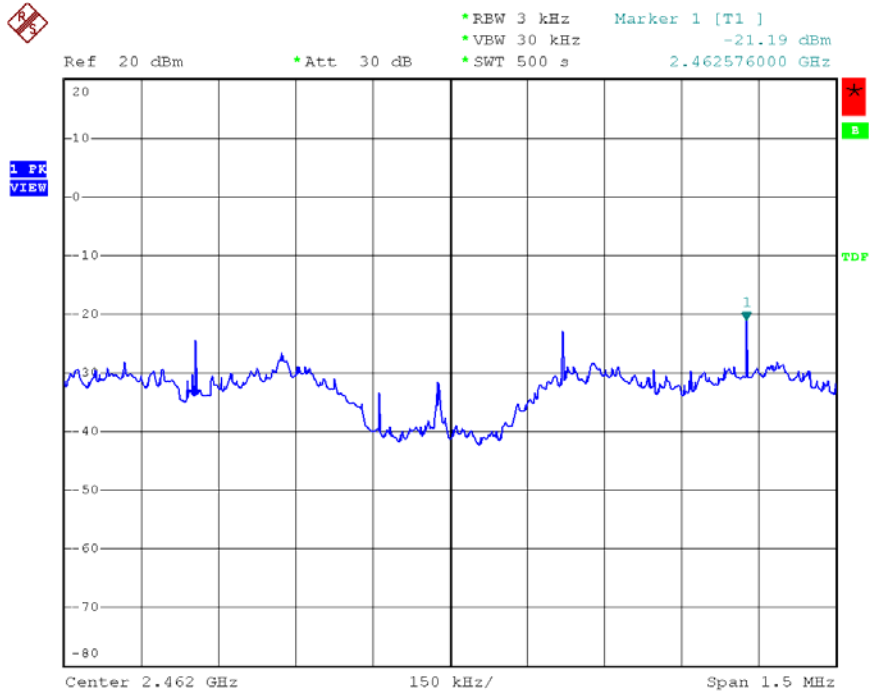

Date: 26.MAY.2008 16:26:11

Modulation Standard: 802.11n, HT20 (130Mbps), ANT-R
Channel: 01

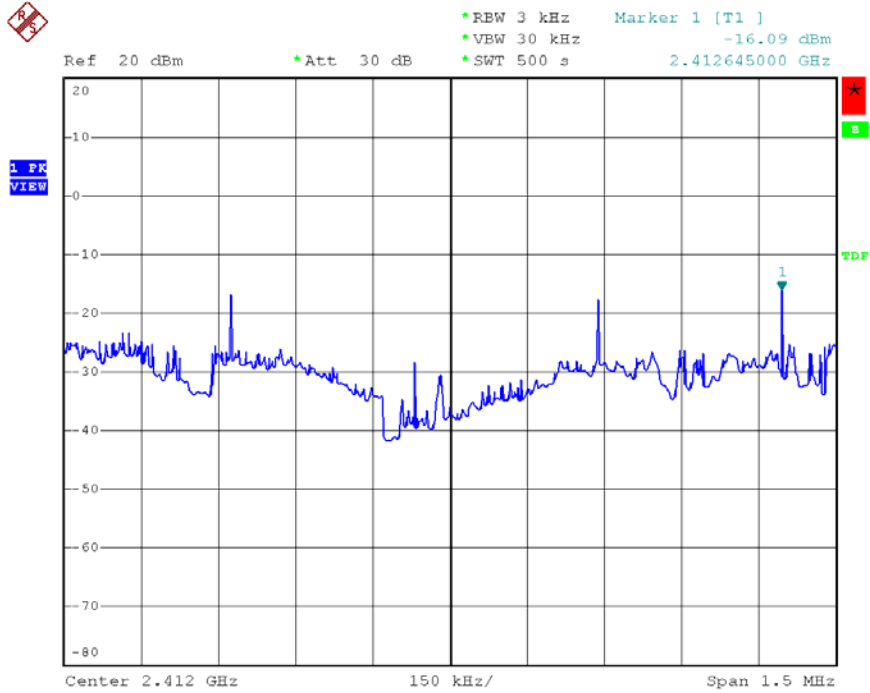

Date: 26.MAY.2008 16:41:15

Modulation Standard: 802.11n, HT20 (130Mbps), ANT-R
Channel: 06

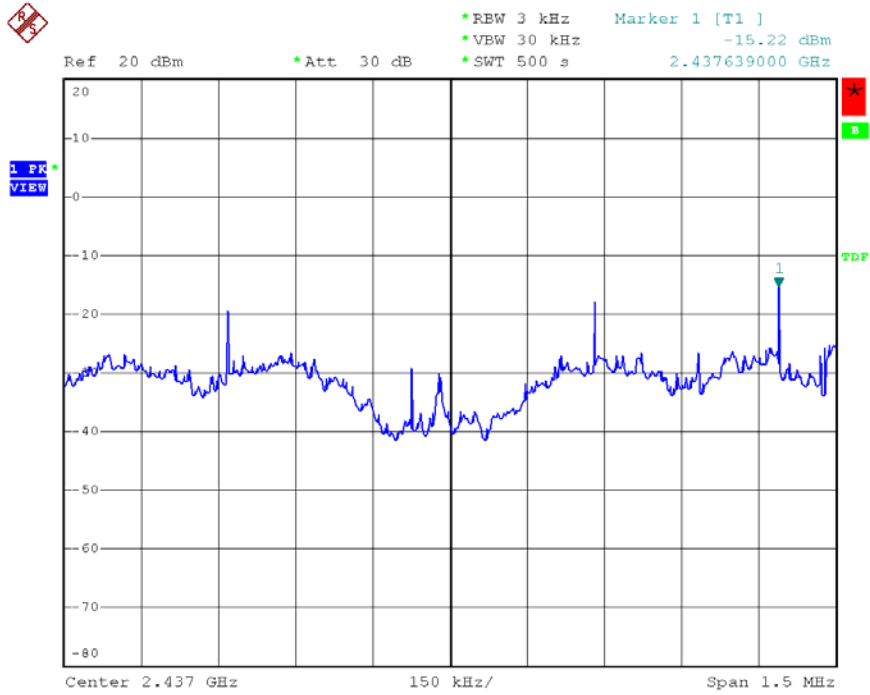

Date: 26.MAY.2008 16:50:13

Modulation Standard: 802.11n, HT20 (130Mbps), ANT-R
Channel: 11

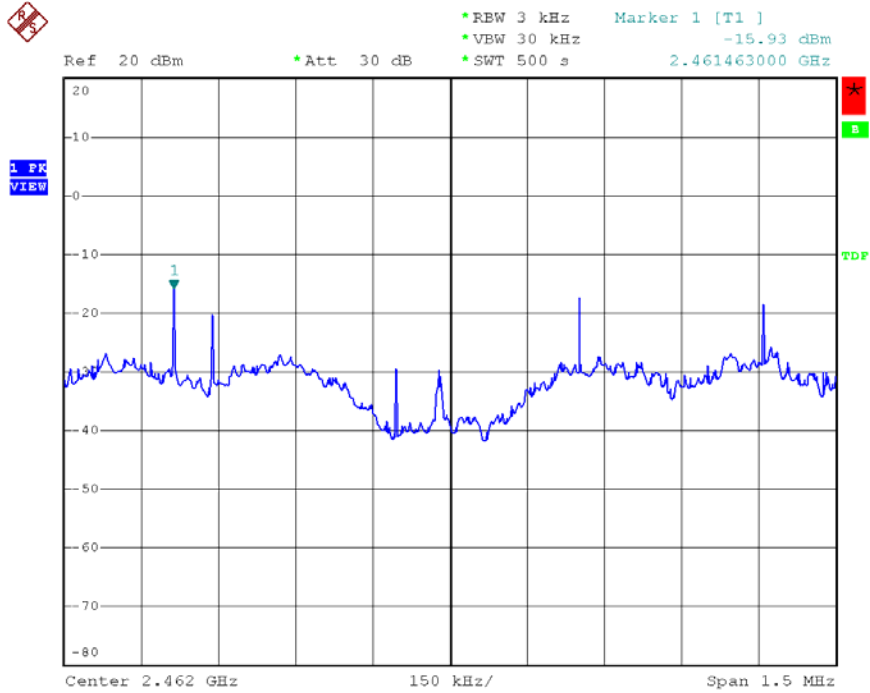

Date: 26.MAY.2008 17:02:43

Modulation Standard: 802.11n, HT40 (270Mbps), ANT-L
Channel: 03

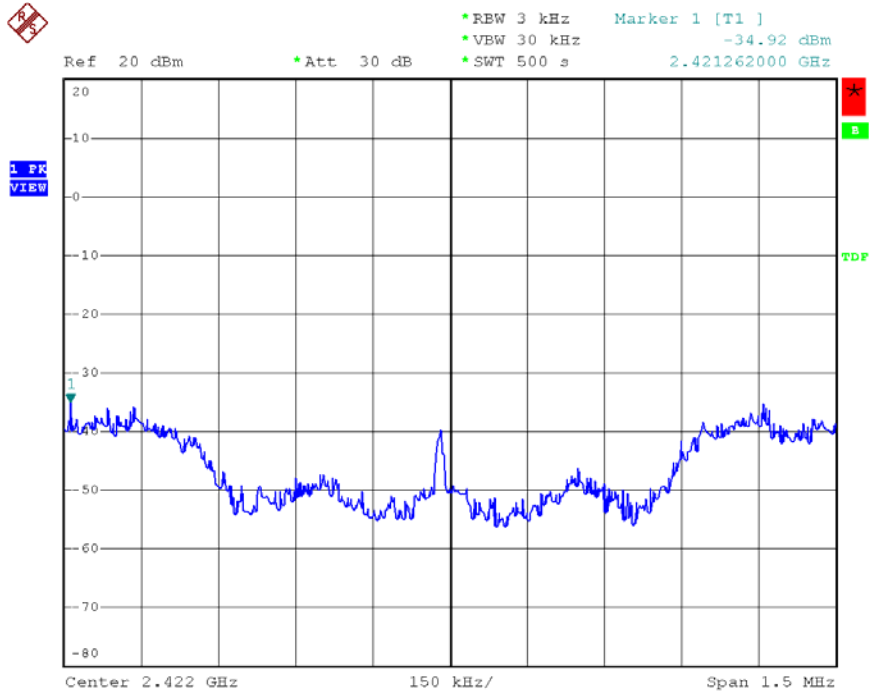

Date: 26.MAY.2008 19:49:37

Modulation Standard: 802.11n, HT40 (270Mbps), ANT-L
Channel: 06

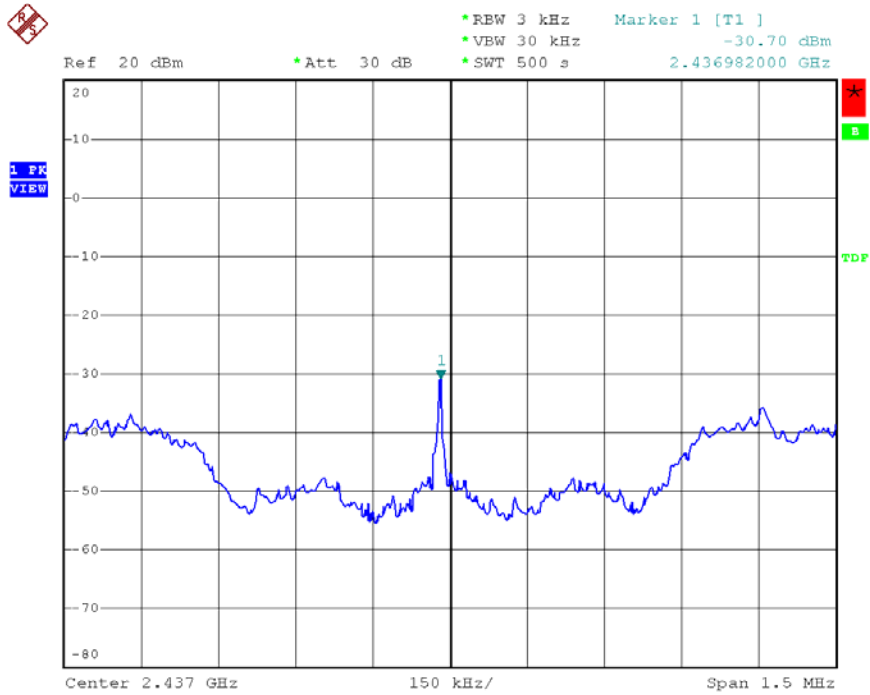

Date: 26.MAY.2008 19:52:30

Modulation Standard: 802.11n, HT40 (270Mbps), ANT-L
Channel: 09

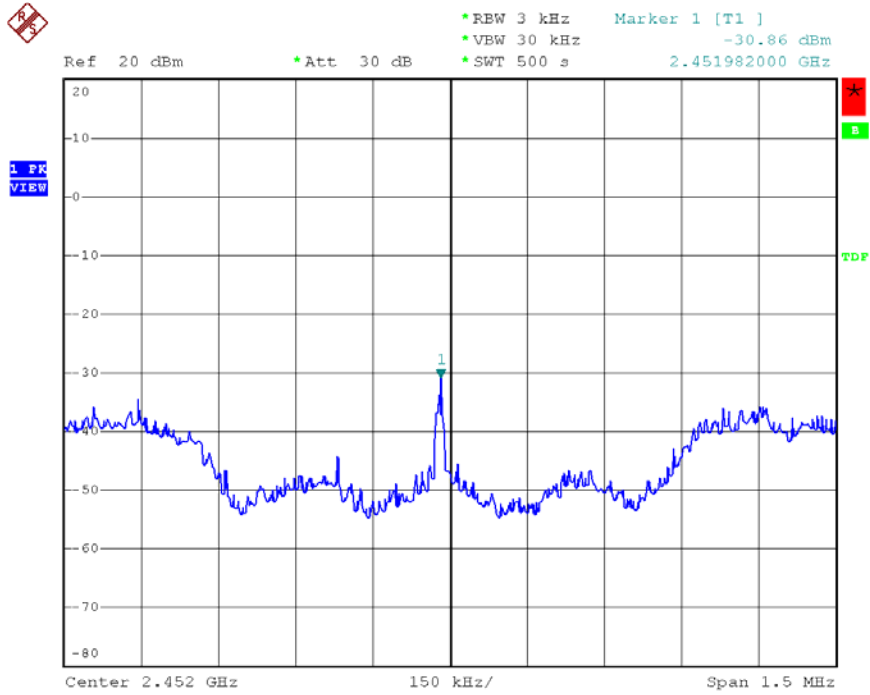

Date: 26.MAY.2008 19:54:14

Modulation Standard: 802.11n, HT40 (270Mbps), ANT-R
Channel: 03

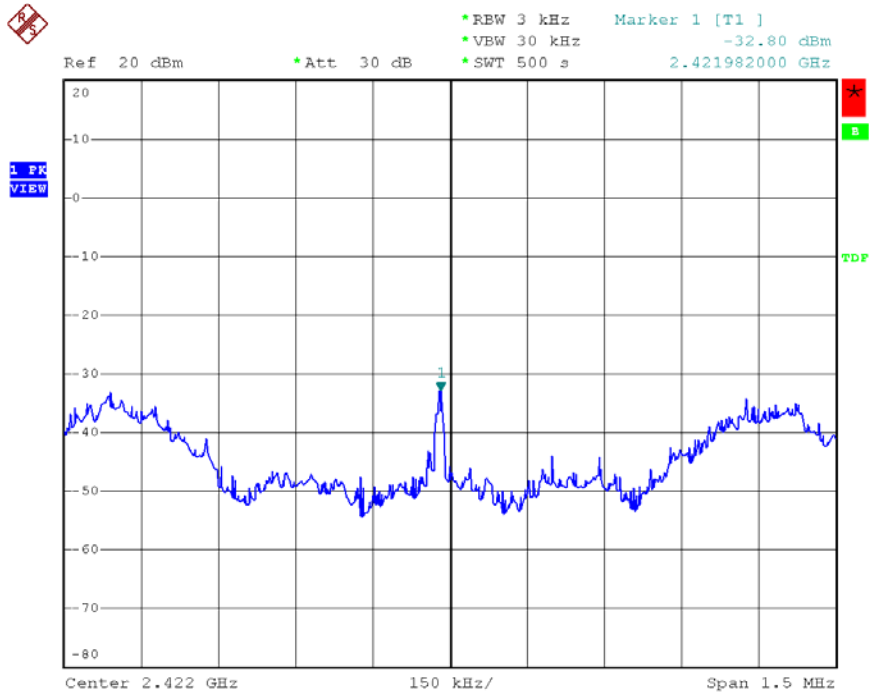

Date: 26.MAY.2008 19:58:41

Modulation Standard: 802.11n, HT40 (270Mbps) , ANT-R
 Channel: 06

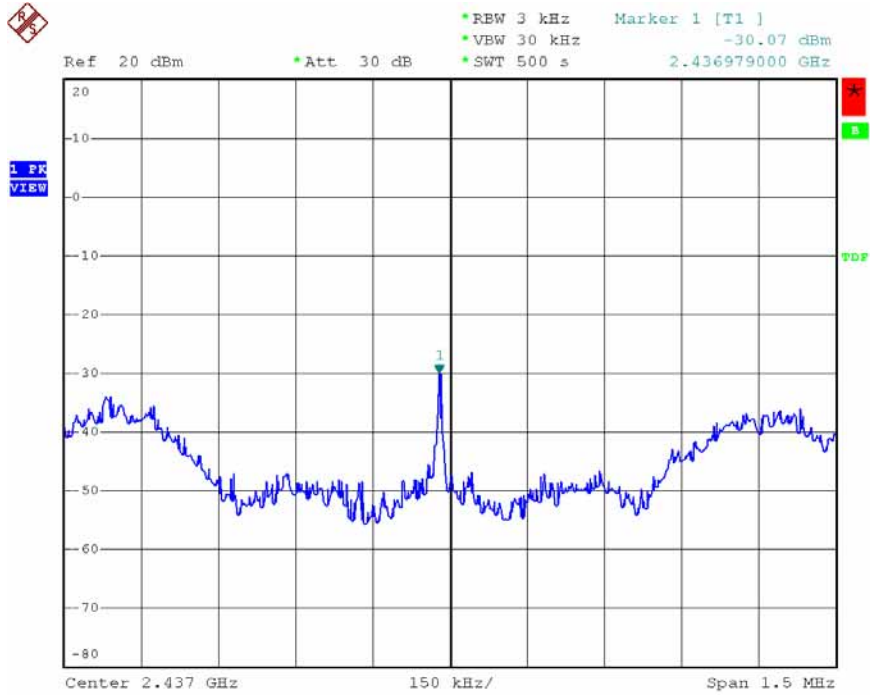

Date: 26.MAY.2008 19:57:35

Modulation Standard: 802.11n, HT40 (270Mbps) , ANT-R
 Channel: 09

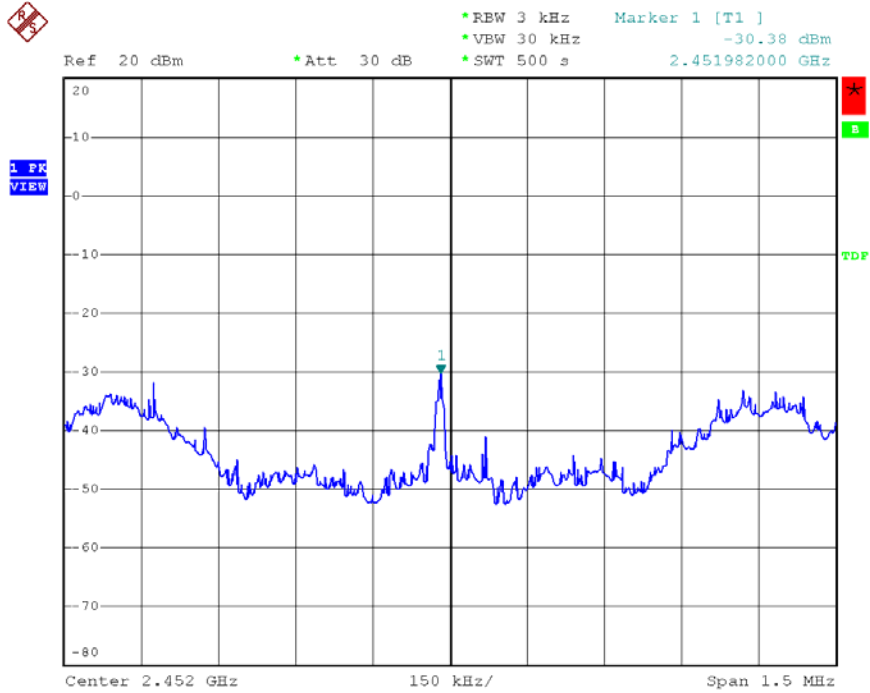

Date: 26.MAY.2008 19:56:43

10. Restricted Bands of Operation

Only spurious emissions are permitted in any of the frequency bands listed below:

MHz	MHz	MHz	GHz
0.09000 – 0.11000	16.42000 – 16.42300	399.9 – 410.0	4.500 – 5.250
0.49500 – 0.505**	16.69475 – 16.69525	608.0 – 614.0	5.350 – 5.460
2.17350 – 2.19050	16.80425 – 16.80475	960.0 – 1240.0	7.250 – 7.750
4.12500 – 4.12800	25.50000 – 25.67000	1300.0 – 1427.0	8.025 – 8.500
4.17725 – 4.17775	37.50000 – 38.25000	1435.0 – 1626.5	9.000 – 9.200
4.20725 – 4.20775	73.00000 – 74.60000	1645.5 – 1646.5	9.300 – 9.500
6.21500 – 6.21800	74.80000 – 75.20000	1660.0 – 1710.0	10.600 – 12.700
6.26775 – 6.26825	108.00000 – 121.94000	1718.8 – 1722.2	13.250 – 13.400
6.31175 – 6.31225	123.00000 – 138.00000	2200.0 – 2300.0	14.470 – 14.500
8.29100 – 8.29400	149.90000 – 150.05000	2310.0 – 2390.0	15.350 – 16.200
8.36200 – 8.36600	156.52475 – 156.52525	2483.5 – 2500.0	17.700 – 21.400
8.37625 – 8.38675	156.70000 – 156.90000	2655.0 – 2900.0	22.010 – 23.120
8.41425 – 8.41475	162.01250 – 167.17000	3260.0 – 3267.0	23.600 – 24.000
12.29000 – 12.29300	167.72000 – 173.20000	3332.0 – 3339.0	31.200 – 31.800
12.51975 – 12.52025	240.00000 – 285.00000	3345.8 – 3358.0	36.430 – 36.500
12.57675 – 12.57725	322.00000 – 335.40000	3600.0 – 4400.0	Above 38.6
13.36000 – 13.41000			

** : Until February 1, 1999, this restricted band shall be 0.490-0.510 MHz

10.1 Labeling Requirement

The device shall bear the following statement in a conspicuous location on the device:

This device complies with part 15 of the FCC Rules. Operation is subject to the following two conditions: (1) This device may not cause harmful interference, and (2) this device must accept any interference received, including interference that may cause undesired operation.