



SPORTON International Inc.

No. 52, Hwa Ya 1st Rd., Kwei-Shan Hsiang, TaoYuan Hsien, Taiwan, R.O.C.
Ph: 886-3-327-3456 / FAX: 886-3-327-0973 / www.sporton.com.tw

FCC RADIO TEST REPORT

Applicant's company	NETGEAR Inc.
Applicant Address	4500 Great America Parkway, Santa Clara, CA 95054, USA
FCC ID	PY307300072
Manufacturer's company	Ambit Microsystems (Shanghai) Ltd.
Manufacturer Address	No. 1925, Nanle Road, Songjiang Export Processing Zone, Shanghai, China

Product Name	RangeMax Duo Wireless-N Router
Brand Name	NETGEAR
Model Name	WNDR3300
Test Rule	47 CFR FCC Part 15 Subpart C § 15.247
Test Freq. Range	2400 ~ 2483.5MHz / 5725 ~ 5850MHz
Received Date	Nov. 24, 2007
Final Test Date	Dec. 11, 2007
Submission Type	Original Equipment



Statement

Test result included is only for the Draft n part of the product.

The test result in this report refers exclusively to the presented test model / sample.

Without written approval of SPORTON International Inc., the test report shall not be reproduced except in full.

The measurements and test results shown in this test report were made in accordance with the procedures and found in compliance with the limit given in **ANSI C63.4-2003** and **47 CFR FCC Part 15 Subpart C**.

The test equipment used to perform the test is calibrated and traceable to NML/ROC.



Table of Contents

1. CERTIFICATE OF COMPLIANCE	1
2. SUMMARY OF THE TEST RESULT	2
3. GENERAL INFORMATION	3
3.1. Product Details.....	3
3.2. Accessories.....	4
3.3. Table for Filed Antenna.....	5
3.4. Table for Carrier Frequencies	6
3.5. Table for Test Modes	6
3.6. Table for Testing Locations.....	8
3.7. Table for Supporting Units	8
3.8. Table for Parameters of Test Software Setting	8
3.9. Test Configurations	10
4. TEST RESULT	12
4.1. AC Power Line Conducted Emissions Measurement.....	12
4.2. Maximum Peak Output Power Measurement	16
4.3. Power Spectral Density Measurement	21
4.4. 6dB Spectrum Bandwidth Measurement	30
4.5. Radiated Emissions Measurement	39
4.6. Band Edge Emissions Measurement	67
4.7. Antenna Requirements	76
5. LIST OF MEASURING EQUIPMENTS	77
6. TEST LOCATION.....	79
7. TAF CERTIFICATE OF ACCREDITATION	80
APPENDIX A. PHOTOGRAPHS OF EUT.....	A1 ~ A17
APPENDIX B. TEST PHOTOS.....	B1 ~ B5
APPENDIX C. MPE REPORT	C1 ~ C3



History of This Test Report

Original Issue Date: Dec. 28, 2007

Report No.: FR7N2806AC

No additional attachment.

Additional attachment were issued as following record:

Attachment No.	Issue Date	Description



1. CERTIFICATE OF COMPLIANCE

Product Name : RangeMax Duo Wireless-N Router
Brand Name : NETGEAR
Model Name : WNDR3300
Applicant : NETGEAR Inc.
Test Rule Part(s) : 47 CFR FCC Part 15 Subpart C § 15.247

Sporton International as requested by the applicant to evaluate the EMC performance of the product sample received on Nov. 24, 2007 would like to declare that the tested sample has been evaluated and found to be in compliance with the tested rule parts. The data recorded as well as the test configuration specified is true and accurate for showing the sample's EMC nature.

A handwritten signature in blue ink that reads 'Wayne Hsu' followed by a date '12.28.07'.

Wayne Hsu

SPORTON INTERNATIONAL INC.

2. SUMMARY OF THE TEST RESULT

Applied Standard: 47 CFR FCC Part 15 Subpart C				
Part	Rule Section	Description of Test	Result	Under Limit
4.1	15.207	AC Power Line Conducted Emissions	Complies	7.81 dB
4.2	15.247(b)(3)	Maximum Peak Conducted Output Power	Complies	0.56 dB
4.3	15.247(e)	Power Spectral Density	Complies	7.20 dB
4.4	15.247(a)(2)	6dB Spectrum Bandwidth	Complies	-
4.5	15.247(d)	Radiated Emissions	Complies	0.31 dB
4.6	15.247(d)	Band Edge Emissions	Complies	0.17 dB
4.7	15.203	Antenna Requirements	Complies	-

Test Items	Uncertainty	Remark
AC Power Line Conducted Emissions	±2.3dB	Confidence levels of 95%
Maximum Peak Conducted Output Power	±0.8dB	Confidence levels of 95%
Power Spectral Density	±0.5dB	Confidence levels of 95%
6dB Spectrum Bandwidth	±8.5×10 ⁻⁸	Confidence levels of 95%
Radiated Emissions (9kHz~30MHz)	±0.8dB	Confidence levels of 95%
Radiated Emissions (30MHz~1000MHz)	±1.9dB	Confidence levels of 95%
Radiated / Band Edge Emissions (1GHz~18GHz)	±1.9dB	Confidence levels of 95%
Radiated Emissions (18GHz~40GHz)	±1.9dB	Confidence levels of 95%
Temperature	±0.7°C	Confidence levels of 95%
Humidity	±3.2%	Confidence levels of 95%
DC / AC Power Source	±1.4%	Confidence levels of 95%

3. GENERAL INFORMATION

3.1. Product Details

Items	Description
Product Type	WLAN
Radio Type	Intentional Transceiver
Power Type	From Adapter
Modulation	see the below table for draft n
Data Modulation	OFDM (BPSK / QPSK / 16QAM / 64QAM)
Data Rate (Mbps)	see the below table for Draft n
Frequency Range	2400 ~ 2483.5MHz / 5725 ~ 5850MHz
Channel Number	11 for 20MHz bandwidth ; 7 for 40MHz bandwidth
Channel Band Width (99%)	MCS8 (20MHz) : 17.59 MHz ; MCS8 (40MHz) : 36.02 MHz 11a MCS8 (20MHz) : 17.62 MHz ; 11a MCS8 (40MHz) : 35.57 MHz
Conducted Output Power	MCS8 (20MHz) : 29.44 dBm ; MCS8 (40MHz) : 26.08 dBm 11a MCS8 (20MHz) : 27.39 MHz ; 11a MCS8 (40MHz) : 22.30 MHz
Carrier Frequencies	Please refer to section 3.4
Antenna	Please refer to section 3.3

Antenna & Band width (for Broadcom a/b/g/n chip_BCM2055)

Antenna	Single (TX)		Two (TX)	
Band width Mode	20 MHz	40 MHz	20 MHz	40 MHz
Draft n	X	X	V	V

Draft n spec

MCS Index	Nss	Modulation	R	NBPS	NCBPS		NDBPS		Data rate(Mbps)			
					800nsGI		20MHz	40MHz	20MHz	40MHz	20MHz	40MHz
					20MHz	40MHz						
0	1	BPSK	$\frac{1}{2}$	1	52	108	26	54	6.5	13.5		
1	1	QPSK	$\frac{1}{2}$	2	104	216	52	108	13.0	27.0		
2	1	QPSK	$\frac{3}{4}$	2	104	216	78	162	19.5	40.5		
3	1	16-QAM	$\frac{1}{2}$	4	208	432	104	216	26.0	54.0		
4	1	16-QAM	$\frac{3}{4}$	4	208	432	156	324	39.0	81.0		
5	1	64-QAM	$\frac{2}{3}$	6	312	648	208	432	52.0	108.0		
6	1	64-QAM	$\frac{3}{4}$	6	312	648	234	486	58.5	121.5		
7	1	64-QAM	$\frac{5}{6}$	6	312	648	260	540	65.0	135.0		
8	2	BPSK	$\frac{1}{2}$	1	104	216	52	108	13.0	27.0		
9	2	QPSK	$\frac{1}{2}$	2	208	432	104	216	26.0	54.0		
10	2	QPSK	$\frac{3}{4}$	2	208	432	156	324	39.0	81.0		
11	2	16-QAM	$\frac{1}{2}$	4	416	864	208	432	52.0	108.0		
12	2	16-QAM	$\frac{3}{4}$	4	416	864	312	648	78.0	162.0		
13	2	64-QAM	$\frac{2}{3}$	6	624	1296	416	864	104.0	216.0		
14	2	64-QAM	$\frac{3}{4}$	6	624	1296	468	972	117.0	243.0		
15	2	64-QAM	$\frac{5}{6}$	6	624	1296	520	1080	130.0	270.0		

Symbol	Explanation
NSS	Number of spatial streams
R	Code rate
NBPS	Number of coded bits per single carrier
NCBPS	Number of coded bits per symbol
NDBPS	Number of data bits per symbol
GI	guard interval

3.2. Accessories

Power	Brand	Model	Rating
Adapter 1	NETGEAR	DSA-20P-10 US 120180	Input: 100-240VAC, 50/60Hz, 0.7A Output: 12VDC, 1.5A
Adapter 2	NETGEAR	MU18-2120150-A1	Input: 100-240VAC, 50/60Hz, 0.6A Output: 12VDC, 1.5A

3.3. Table for Filed Antenna

For 2.4GHz Band for Broadcomm b/g chip_BCM4318

Ant.	Brand	Model Name	Antenna Type	Connector	Gain (dBi)	Remark
1	-	-	Printed Antenna	NA	3.39	TX / RX Ant.
2	-	-	Printed Antenna	NA	4.37	RX Ant.

For 2.4GHz Band for Broadcomm a/b/g/n chip_BCM2055

Ant.	Brand	Model Name	Antenna Type	Connector	Gain (dBi)	Remark
3	-	-	Printed Antenna	NA	2.51	TX / RX Ant.
4	-	-	Printed Antenna	NA	3.45	RX Ant.
5	-	-	Printed Antenna	NA	2.51	TX / RX Ant.

For 5GHz Band for Broadcomm a/b/g/n chip_BCM2055

Ant.	Brand	Model Name	Antenna Type	Connector	Gain (dBi)	Remark
3	-	-	Printed Antenna	NA	6.92	TX / RX Ant.
4	-	-	Printed Antenna	NA	6.50	RX Ant.
5	-	-	Printed Antenna	NA	6.92	TX / RX Ant.

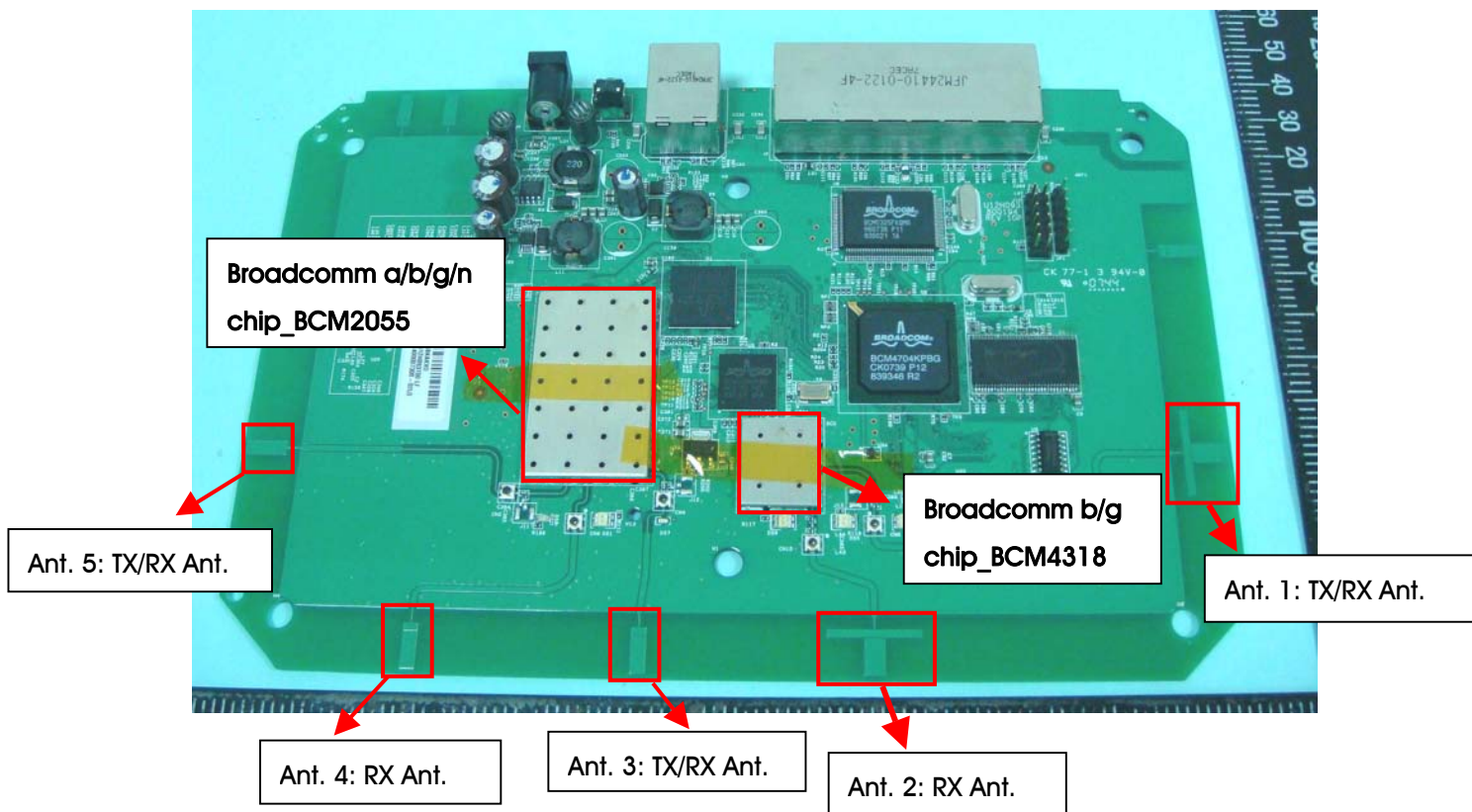

3.4. Table for Carrier Frequencies

There are two bandwidth systems for draft n.

For both 20MHz bandwidth systems, use Channel 1~Channel 11.

For both 40MHz bandwidth systems, use Channel 3~Channel 9.

Frequency Band	Channel No.	Frequency	Channel No.	Frequency
2400~2483.5MHz	1	2412 MHz	7	2442 MHz
	2	2417 MHz	8	2447 MHz
	3	2422 MHz	9	2452 MHz
	4	2427 MHz	10	2457 MHz
	5	2432 MHz	11	2462 MHz
	6	2437 MHz		

There are two bandwidth systems for draft n.

For both 20MHz bandwidth systems, use Channel 149, 157, 165.

For both 40MHz bandwidth systems, use Channel 151, 159.

Frequency Band	Channel No.	Frequency	Channel No.	Frequency
5725~5850 MHz	149	5745 MHz	161	5805 MHz
	151	5755 MHz	165	5825 MHz
	153	5765 MHz		
	157	5785 MHz		
	159	5795 MHz		

3.5. Table for Test Modes

Preliminary tests were performed in different data rate to find the worst radiated emission. The data rate shown in the table below is the worst-case rate with respect to the specific test item. Investigation has been done on all the possible configurations for searching the worst cases. The following table is a list of the test modes shown in this test report.

Test Items	Mode	Data Rate	Channel	Antenna
AC Power Line Conducted Emissions	Normal Link	Auto	-	-
Maximum Peak Conducted Output Power	MCS8/20MHz	13 Mbps	1/6/11	3 / 5 / 3+5
	MCS8/40MHz	27 Mbps	3/6/9	3 / 5 / 3+5
	MCS8/20MHz	13 Mbps	149/157/165	3 / 5 / 3+5
	MCS8/40MHz	27 Mbps	151/159	3 / 5 / 3+5
Power Spectral Density 6dB Spectrum Bandwidth	MCS8/20MHz	13 Mbps	1/6/11	3+5
	MCS8/40MHz	27 Mbps	3/6/9	3+5
	MCS8/20MHz	13 Mbps	149/157/165	3 / 5 / 3+5
	MCS8/40MHz	27 Mbps	151/159	3 / 5 / 3+5
Radiated Emissions 9kHz~1GHz	Draft n /BPSK	27 Mbps	6	3+5
Radiated Emissions 1GHz~10 th Harmonic	MCS8/20MHz	13 Mbps	1/6/11	3+5
	MCS8/40MHz	27 Mbps	3/6/9	3+5
	MCS8/20MHz	13 Mbps	149/157/165	3 / 5 / 3+5
	MCS8/40MHz	27 Mbps	151/159	3 / 5 / 3+5
Band Edge Emissions	MCS8/20MHz	13 Mbps	1/11	3+5
	MCS8/40MHz	27 Mbps	3/9	3+5
	MCS8/20MHz	13 Mbps	149/165	3 / 5 / 3+5
	MCS8/40MHz	27 Mbps	151/159	3 / 5 / 3+5

There have two test mode below:

Mode 1: Broadcomm a/b/g/n chip_BCM2055+Adapter 1

Mode 2: Broadcomm a/b/g/n chip_BCM2055+Adapter 2

Due to Mode 2 generated the worst test result, so it was recorded in this report.

3.6. Table for Testing Locations

Test Site No.	Site Category	Location	FCC Reg. No.	IC File No.	VCCI Reg. No
03CH03-HY	SAC	Hwa Ya	101377	IC 4088	-
CO04-HY	Conduction	Hwa Ya	101377	IC 4088	-
TH01-HY	OVEN Room	Hwa Ya	-	-	-

Open Area Test Site (OATS); Semi Anechoic Chamber (SAC); Fully Anechoic Chamber (FAC).

Please refer section 6 for Test Site Address.

3.7. Table for Supporting Units

Support Unit	Brand	Model	FCC ID
Notebook	DELL	D505	E2K24GBRL
Notebook	DELL	D505	E2K24GBRL
Notebook	DELL	D400	E2K24GBRL

3.8. Table for Parameters of Test Software Setting

During testing, Channel & Power Controlling Software provided by the customer was used to control the operating channel as well as the output power level. The RF output power selection is for the setting of RF output power expected by the customer and is going to be fixed on the firmware of the final end product.

Power Parameters of Draft n MCS8 20MHz Ant. 3+Ant. 5

Test Software Version	Telnet		
Frequency	2412 MHz	2437 MHz	2462 MHz
Draft n	3C3D	1D16	3B3A

Power Parameters of Draft n MCS8 40MHz Ant. 3+Ant. 5

Test Software Version	Telnet		
Frequency	2422 MHz	2437 MHz	2452 MHz
Draft n	403C	3B3A	3935

Power Parameters of 11a Draft n MCS8 20MHz Ant. 3+Ant. 5

Test Software Version	Telnet		
Frequency	5745 MHz	5785 MHz	5825 MHz
Draft n	1a20	1a20	1a20

Power Parameters of 11a Draft n MCS8 40MHz Ant. 3+Ant. 5

Test Software Version	Telnet	
Frequency	5755 MHz	5795 MHz
Draft n	252b	252b

During the test, the following programs under WIN XP were executed:

Executed " telnet " to control the EUT continuously transmit RF signal.

Executed "ping.exe" to link with the remote workstation to receive and transmit signal by LAN and WLAN.

3.9. Test Configurations

3.9.1. Radiation Emissions Test Configuration

Test Configuration: 9KHz~1GHz

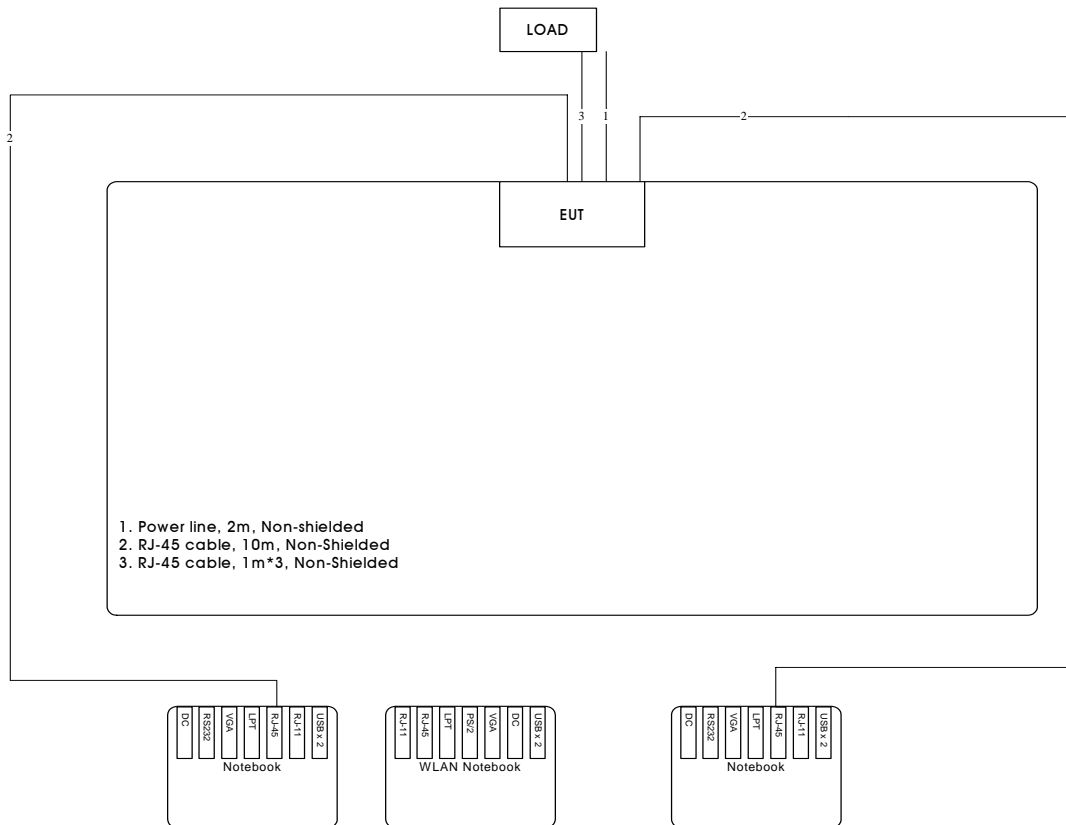

Test Configuration: above 1GHz

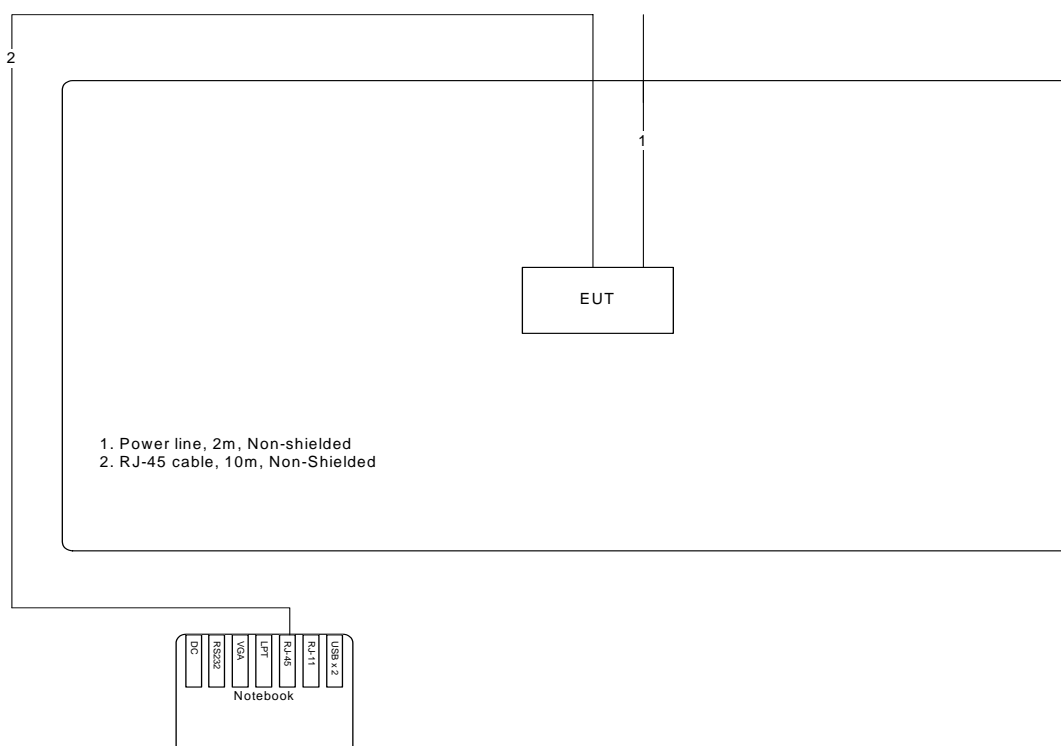

3.9.2. AC Power Line Conduction Emissions Test Configuration

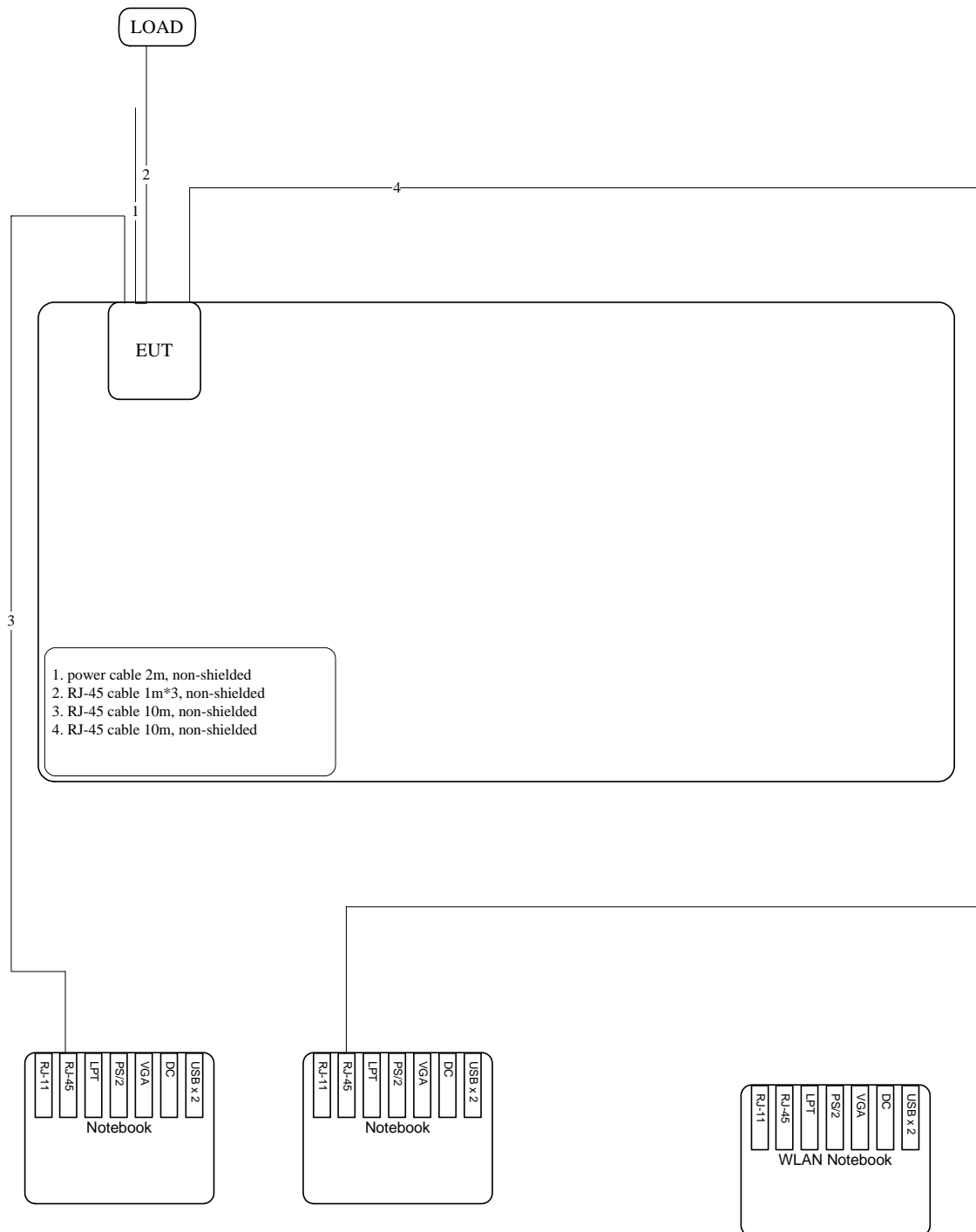

4. TEST RESULT

4.1. AC Power Line Conducted Emissions Measurement

4.1.1. Limit

For this product which is designed to be connected to the AC power line, the radio frequency voltage that is conducted back onto the AC power line on any frequency or frequencies within the band 150 kHz to 30 MHz shall not exceed below limits table.

Frequency (MHz)	QP Limit (dBuV)	AV Limit (dBuV)
0.15~0.5	66~56	56~46
0.5~5	56	46
5~30	60	50

4.1.2. Measuring Instruments and Setting

Please refer to section 5 of equipments list in this report. The following table is the setting of the receiver.

Receiver Parameters	Setting
Attenuation	10 dB
Start Frequency	0.15 MHz
Stop Frequency	30 MHz
IF Bandwidth	9 KHz

4.1.3. Test Procedures

1. Configure the EUT according to ANSI C63.4. The EUT or host of EUT has to be placed 0.4 meter far from the conducting wall of the shielding room and at least 80 centimeters from any other grounded conducting surface.
2. Connect EUT or host of EUT to the power mains through a line impedance stabilization network (LISN).
3. All the support units are connected to the other LISNs. The LISN should provide 50uH/50ohms coupling impedance.
4. The frequency range from 150 KHz to 30 MHz was searched.
5. Set the test-receiver system to Peak Detect Function and Specified Bandwidth with Maximum Hold Mode.
6. The measurement has to be done between each power line and ground at the power terminal.

4.1.4. Test Setup Layout

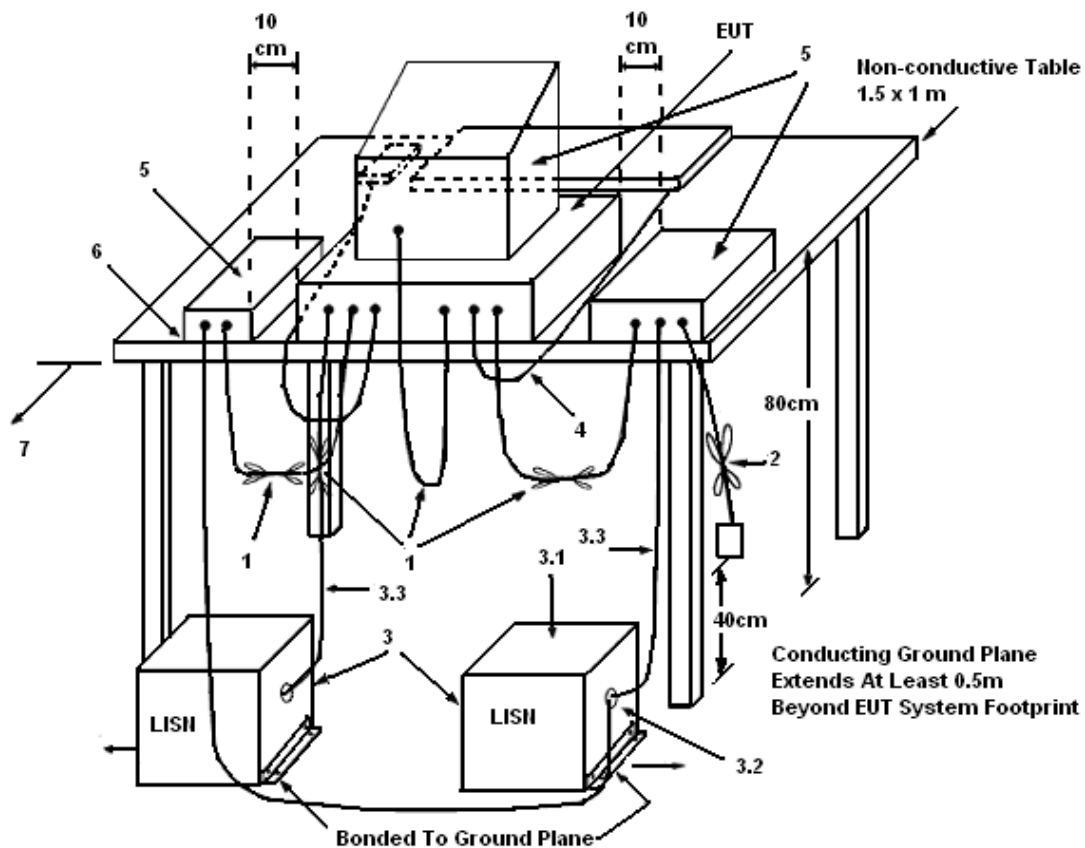

LEGEND:

- (1) Interconnecting cables that hang closer than 40 cm to the ground plane shall be folded back and forth in the center forming a bundle 30 to 40 cm long.
- (2) I/O cables that are not connected to a peripheral shall be bundled in the center. The end of the cable may be terminated, if required, using the correct terminating impedance. The overall length shall not exceed 1 m.
- (3) EUT connected to one LISN. Unused LISN measuring port connectors shall be terminated in 50Ω . LISN can be placed on top of, or immediately beneath, reference ground plane.
 - (3.1) All other equipment powered from additional LISN(s).
 - (3.2) Multiple outlet strip can be used for multiple power cords of non-EUT equipment.
 - (3.3) LISN at least 80 cm from nearest part of EUT chassis.
- (4) Cables of hand-operated devices, such as keyboards, mice, etc., shall be placed as for normal use.
- (5) Non-EUT components of EUT system being tested.
- (6) Rear of EUT, including peripherals, shall all be aligned and flush with rear of tabletop.
- (7) Rear of tabletop shall be 40 cm removed from a vertical conducting plane that is bonded to the ground plane.

4.1.5. Test Deviation

There is no deviation with the original standard.

4.1.6. EUT Operation during Test

The EUT was placed on the test table and programmed in normal function.

4.1.7. Results of AC Power Line Conducted Emissions Measurement

Temperature	23°C	Humidity	54%
Test Engineer	Barry Chen	Phase	Line
Configuration	Normal Link		

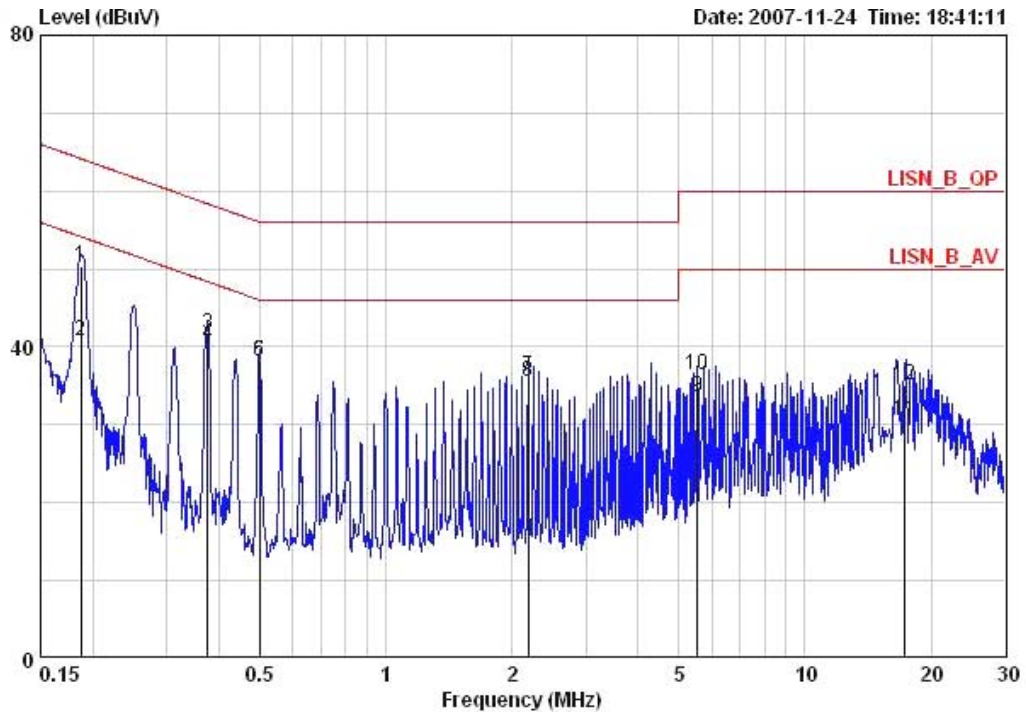

	Freq	Level	Over Limit	Limit Line	Read Level	LISN Factor	Cable Loss	Remark	Pol/Phase
	MHz	dBuV	dB	dBuV	dBuV	dB	dB		
1	0.18699	50.37	-13.80	64.17	50.02	0.15	0.20	QP	LINE
2	0.18699	40.77	-13.40	54.17	40.42	0.15	0.20	AVERAGE	LINE
3	0.37512	41.63	-16.76	58.39	41.33	0.10	0.20	QP	LINE
4	0.37512	40.43	-7.96	48.39	40.13	0.10	0.20	AVERAGE	LINE
5	0.49897	38.20	-17.82	56.02	37.92	0.08	0.20	QP	LINE
6	0.49897	38.17	-7.85	46.02	37.89	0.08	0.20	AVERAGE	LINE
7	2.184	36.20	-19.80	56.00	36.00	0.00	0.20	QP	LINE
8	2.184	35.52	-10.48	46.00	35.32	0.00	0.20	AVERAGE	LINE
9	5.553	33.56	-16.44	50.00	33.23	0.03	0.30	AVERAGE	LINE
10	5.553	36.47	-23.53	60.00	36.14	0.03	0.30	QP	LINE
11	17.286	30.50	-19.50	50.00	29.90	0.10	0.50	AVERAGE	LINE
12	17.286	35.20	-24.80	60.00	34.60	0.10	0.50	QP	LINE

Temperature	23°C	Humidity	54%
Test Engineer	Barry Chen	Phase	Neutral
Configuration	Normal Link		

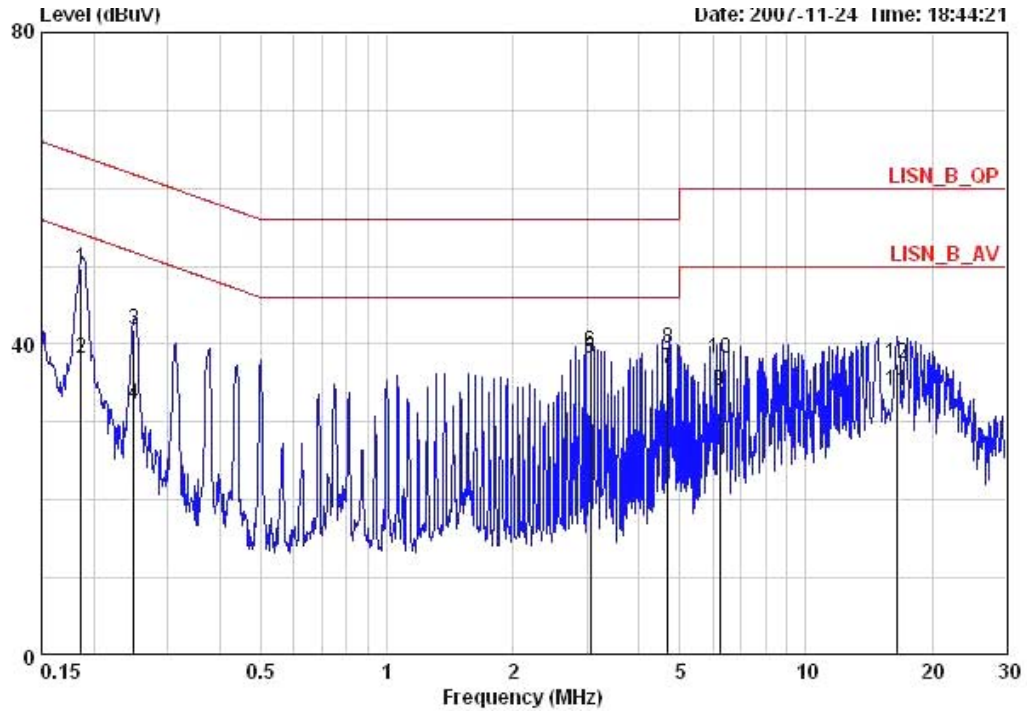

	Freq	Level	Over	Limit	Read	LISN	Cable	Remark	Pol/Phase
	MHz	dBuV	Limit	Line	Level	Factor	Loss		
			dB	dBuV	dBuV	dB	dB		
1	0.18659	49.63	-14.56	64.19	49.18	0.25	0.20	QP	NEUTRAL
2	0.18659	38.16	-16.03	54.19	37.71	0.25	0.20	AVERAGE	NEUTRAL
3	0.24958	41.79	-19.98	61.77	41.41	0.18	0.20	QP	NEUTRAL
4	0.24958	32.23	-19.54	51.77	31.85	0.18	0.20	AVERAGE	NEUTRAL
5	3.058	38.19	-7.81	46.00	37.88	0.10	0.21	AVERAGE	NEUTRAL
6	3.058	38.97	-17.03	56.00	38.66	0.10	0.21	QP	NEUTRAL
7	4.680	36.79	-9.21	46.00	36.39	0.10	0.30	AVERAGE	NEUTRAL
8	4.680	39.50	-16.50	56.00	39.10	0.10	0.30	QP	NEUTRAL
9	6.238	34.05	-15.95	50.00	33.60	0.10	0.35	AVERAGE	NEUTRAL
10	6.238	38.06	-21.94	60.00	37.61	0.10	0.35	QP	NEUTRAL
11	16.471	33.94	-16.06	50.00	33.44	0.10	0.40	AVERAGE	NEUTRAL
12	16.471	37.43	-22.57	60.00	36.93	0.10	0.40	QP	NEUTRAL

Note:

Level = Read Level + LISN Factor + Cable Loss.

4.2. Maximum Peak Output Power Measurement

4.2.1. Limit

For systems using digital modulation in the 2400-2483.5MHz, the limit for peak output power is 30dBm. The limited has to be reduced by the amount in dB that the gain of the antenna exceed 6dBi. In case of point-to-point operation, the limit has to be reduced by 1dB for every 3dB that the directional gain of the antenna exceeds 6dBi.

4.2.2. Measuring Instruments and Setting

Please refer to section 5 of equipments list in this report. The following table is the setting of the spectrum analyzer.

Spectrum Parameter	Setting
Attenuation	Auto
Span Frequency	Encompass the entire emissions bandwidth (EBW) of the signal
RB	1000 kHz
VB	3000 kHz
Detector	PEAK
Trace	MAX HOLD
Sweep Time	20ms

4.2.3. Test Procedures

1. The transmitter output (antenna port) was connected to the spectrum analyzer.
2. Test was performed in accordance with FCC Conference Call, June 10, 2003.
3. When measuring maximum conducted output power with multiple antenna systems, add every result of the values by mathematic formula.

4.2.4. Test Setup Layout

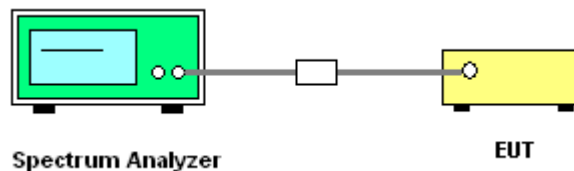

4.2.5. Test Deviation

There is no deviation with the original standard.

4.2.6. EUT Operation during Test

The EUT was programmed to be in continuously transmitting mode.

4.2.7. Test Result of Maximum Peak Output Power

Temperature	23°C	Humidity	56%
Test Engineer	Barry Chen	Configurations	Draft n

Configuration Draft n MCS8 20MHz Ant. 3

Channel	Frequency	Conducted Power (dBm)	Max. Limit (dBm)	Result
1	2412 MHz	21.70	30.00	Complies
6	2437 MHz	26.20	30.00	Complies
11	2462 MHz	21.89	30.00	Complies

Configuration Draft n MCS8 20MHz Ant. 5

Channel	Frequency	Conducted Power (dBm)	Max. Limit (dBm)	Result
1	2412 MHz	22.13	30.00	Complies
6	2437 MHz	26.64	30.00	Complies
11	2462 MHz	22.67	30.00	Complies

Configuration Draft n MCS8 20MHz Ant. 3 + Ant. 5

Channel	Frequency	Conducted Power (dBm)	Max. Limit (dBm)	Result
1	2412 MHz	24.93	30.00	Complies
6	2437 MHz	29.44	30.00	Complies
11	2462 MHz	25.31	30.00	Complies

Configuration Draft n MCS8 40MHz Ant. 3

Channel	Frequency	Conducted Power (dBm)	Max. Limit (dBm)	Result
3	2422 MHz	19.00	30.00	Complies
6	2437 MHz	22.49	30.00	Complies
9	2452 MHz	20.53	30.00	Complies

Configuration Draft n MCS8 40MHz Ant. 5

Channel	Frequency	Conducted Power (dBm)	Max. Limit (dBm)	Result
3	2422 MHz	20.11	30.00	Complies
6	2437 MHz	23.58	30.00	Complies
9	2452 MHz	21.15	30.00	Complies

Configuration Draft n MCS8 40MHz Ant. 3 + Ant. 5

Channel	Frequency	Conducted Power (dBm)	Max. Limit (dBm)	Result
3	2422 MHz	22.60	30.00	Complies
6	2437 MHz	26.08	30.00	Complies
9	2452 MHz	23.86	30.00	Complies

Temperature	23°C	Humidity	56%
Test Engineer	Barry Chen	Configurations	11a Draft n

Configuration 11a Draft n MCS8 20MHz Ant. 3

Channel	Frequency	Conducted Power (dBm)	Max. Limit (dBm)	Result
149	5745 MHz	24.32	29.08	Complies
157	5785 MHz	22.99	29.08	Complies
165	5825 MHz	23.61	29.08	Complies

Configuration 11a Draft n MCS8 20MHz Ant. 5

Channel	Frequency	Conducted Power (dBm)	Max. Limit (dBm)	Result
149	5745 MHz	24.43	29.08	Complies
157	5785 MHz	23.24	29.08	Complies
165	5825 MHz	23.62	29.08	Complies

Configuration 11a Draft n MCS8 20MHz Ant. 3+Ant. 5

Channel	Frequency	Conducted Power (dBm)	Max. Limit (dBm)	Result
149	5745 MHz	27.39	29.08	Complies
157	5785 MHz	26.13	29.08	Complies
165	5825 MHz	26.63	29.08	Complies

Configuration 11a Draft n MCS8 40MHz Ant. 3

Channel	Frequency	Conducted Power (dBm)	Max. Limit (dBm)	Result
151	5755 MHz	18.98	29.08	Complies
159	5795 MHz	18.36	29.08	Complies

Configuration 11a Draft n MCS8 40MHz Ant. 5

Channel	Frequency	Conducted Power (dBm)	Max. Limit (dBm)	Result
151	5755 MHz	19.57	29.08	Complies
159	5795 MHz	18.48	29.08	Complies

Configuration 11a Draft n MCS8 40MHz Ant. 3+Ant. 5

Channel	Frequency	Conducted Power (dBm)	Max. Limit (dBm)	Result
151	5755 MHz	22.30	29.08	Complies
159	5795 MHz	21.43	29.08	Complies

4.3. Power Spectral Density Measurement

4.3.1. Limit

For digitally modulated systems, the power spectral density conducted from the intentional radiator to the antenna shall not be greater than 8 dBm in any 3 kHz band during any time interval of continuous transmission.

4.3.2. Measuring Instruments and Setting

Please refer to section 5 of equipments list in this report. The following table is the setting of Spectrum Analyzer.

Spectrum Parameter	Setting
Attenuation	Auto
Span Frequency	1.5MHz
RB	3 kHz
VB	30 kHz
Detector	Peak
Trace	Max Hold
Sweep Time	500s

4.3.3. Test Procedures

1. The transmitter output (antenna port) was connected to the spectrum analyser.
2. Set RBW of spectrum analyzer to 3kHz and VBW to 30kHz. Set Detector to Peak, Trace to Max Hold.
3. Mark the frequency with maximum peak power as the center of the display of the spectrum.
4. Set the span to 1.5MHz and the sweep time to 500s and record the maximum peak value.
5. Measuring multiple antennas, the connector is required to link with Power Meter through a combiner.

4.3.4. Test Setup Layout

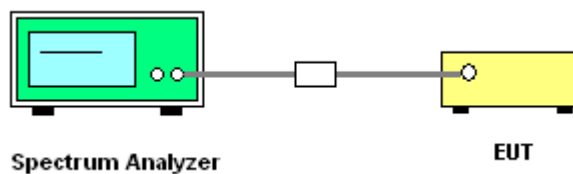

4.3.5. Test Deviation

There is no deviation with the original standard.

4.3.6. EUT Operation during Test

The EUT was programmed to be in continuously transmitting mode.

4.3.7. Test Result of Power Spectral Density

Temperature	23°C	Humidity	56%
Test Engineer	Barry Chen	Configurations	Draft n

Configuration Draft n MCS8 20MHz Ant. 3 + Ant. 5

Channel	Frequency	Power Density (dBm)	Max. Limit (dBm)	Result
1	2412 MHz	-5.58	8.00	Complies
6	2437 MHz	0.80	8.00	Complies
11	2462 MHz	-6.61	8.00	Complies

Configuration Draft n MCS8 40MHz Ant. 3 + Ant. 5

Channel	Frequency	Power Density (dBm)	Max. Limit (dBm)	Result
3	2422 MHz	-10.33	8.00	Complies
6	2437 MHz	-6.77	8.00	Complies
9	2452 MHz	-10.58	8.00	Complies

Temperature	23°C	Humidity	56%
Test Engineer	Barry Chen	Configurations	11a Draft n

Configuration 11a Draft n MCS8 20MHz Ant. 3+Ant. 5

Channel	Frequency	Power Density (dBm)	Max. Limit (dBm)	Result
149	5745 MHz	-4.39	8.00	Complies
157	5785 MHz	-5.70	8.00	Complies
165	5827 MHz	-5.07	8.00	Complies

Configuration 11a Draft n MCS8 40MHz Ant. 3+Ant. 5

Channel	Frequency	Power Density (dBm)	Max. Limit (dBm)	Result
151	5755 MHz	-9.05	8.00	Complies
159	5795 MHz	-9.51	8.00	Complies

Power Density Plot on Configuration Drafft n MCS8 20MHz Ant. 3 + Ant. 5 / 2412 MHz

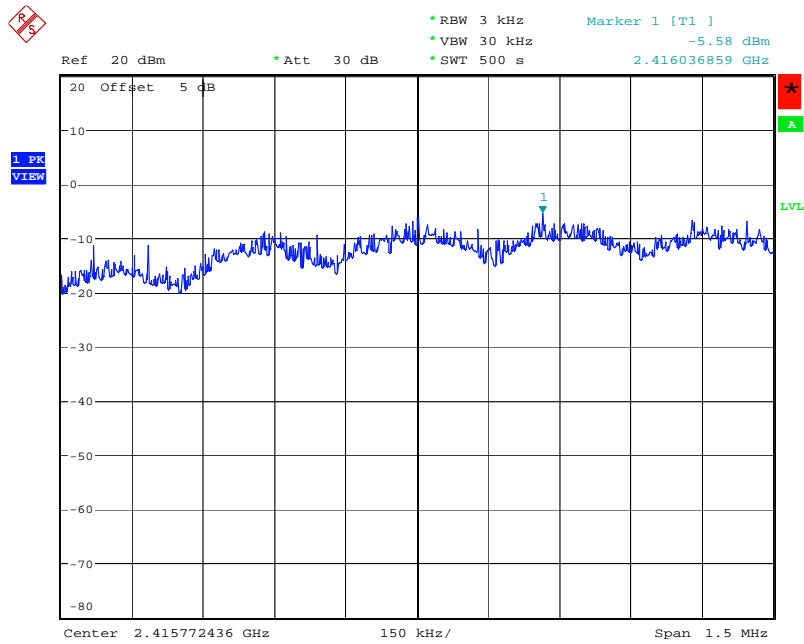

Date: 11.DEC.2007 09:52:26

Power Density Plot on Configuration Drafft n MCS8 20MHz Ant. 3 + Ant. 5 / 2437 MHz

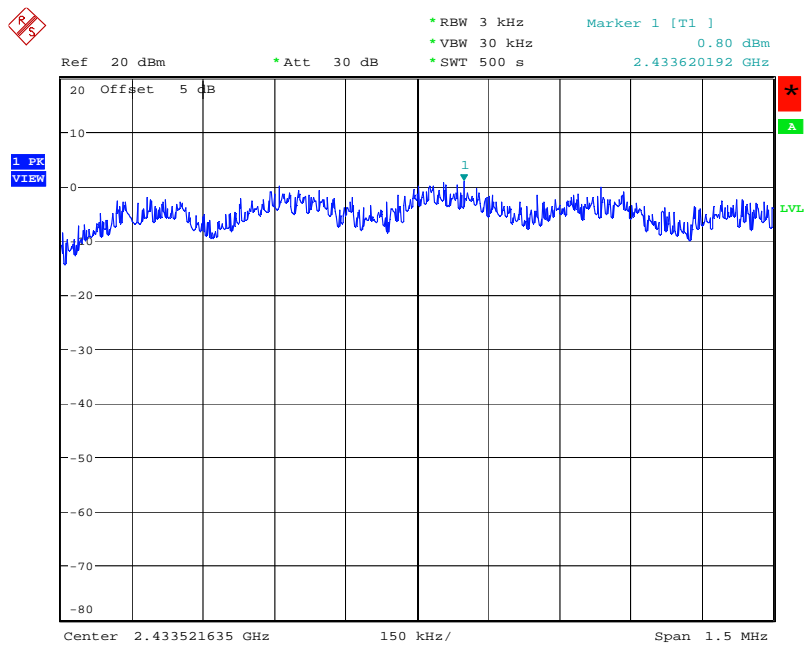

Date: 11.DEC.2007 10:41:26

Power Density Plot on Configuration Drafft n MCS8 20MHz Ant. 3 + Ant. 5 / 2462 MHz

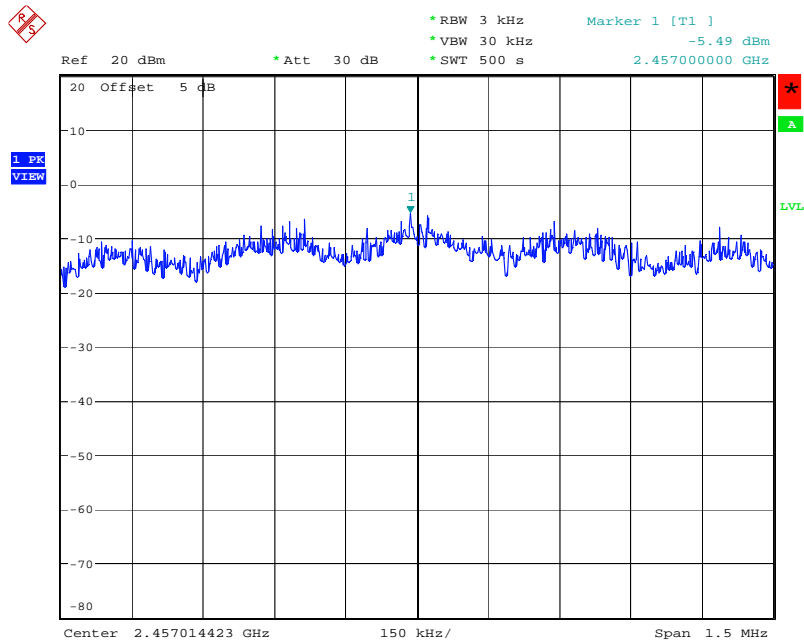

Date: 1.DEC.2007 09:33:43

Power Density Plot on Configuration Drafft n MCS8 40MHz Ant. 3 + Ant. 5 / 2422 MHz

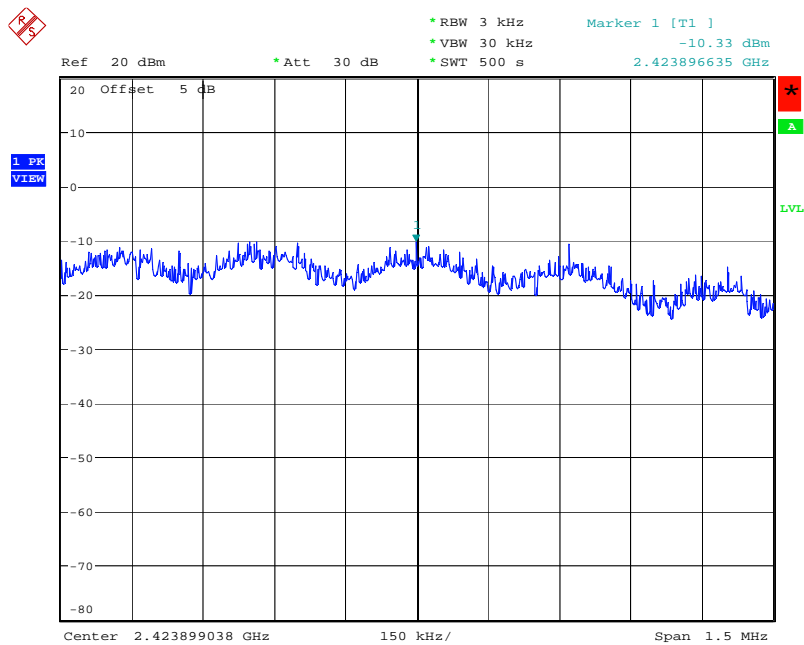

Date: 11.DEC.2007 10:53:31

Power Density Plot on Configuration Draft n MCS8 40MHz Ant. 3 + Ant. 5 / 2437 MHz

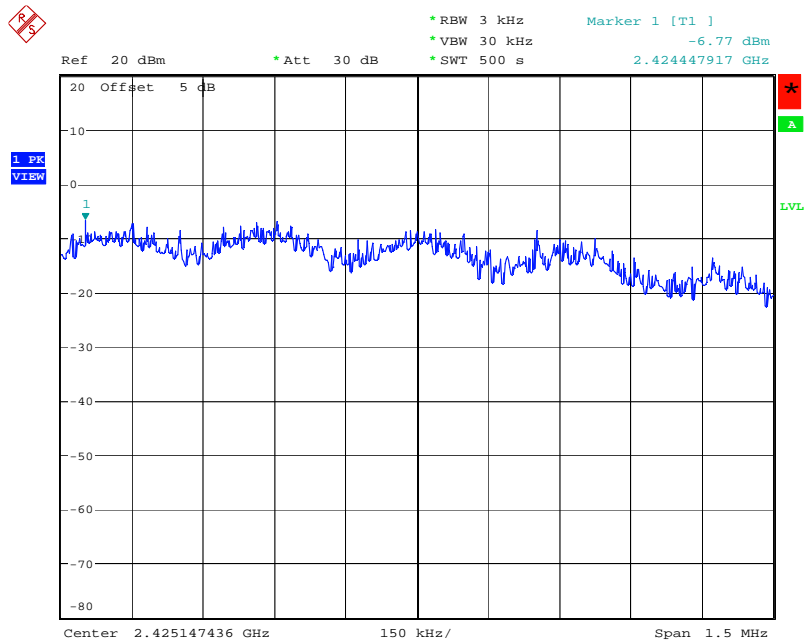

Date: 11.DEC.2007 10:55:18

Power Density Plot on Configuration Draft n MCS8 40MHz Ant. 3 + Ant. 5 / 2452 MHz

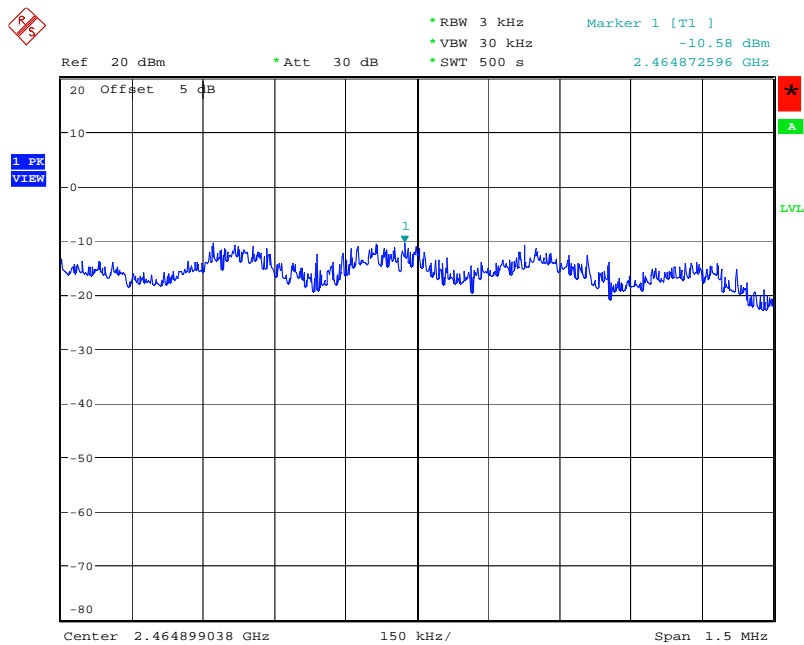

Date: 11.DEC.2007 10:58:55

Power Density Plot on Configuration 11a Draft n MCS8 20MHz Ant. 3+Ant. 5 / 5745 MHz

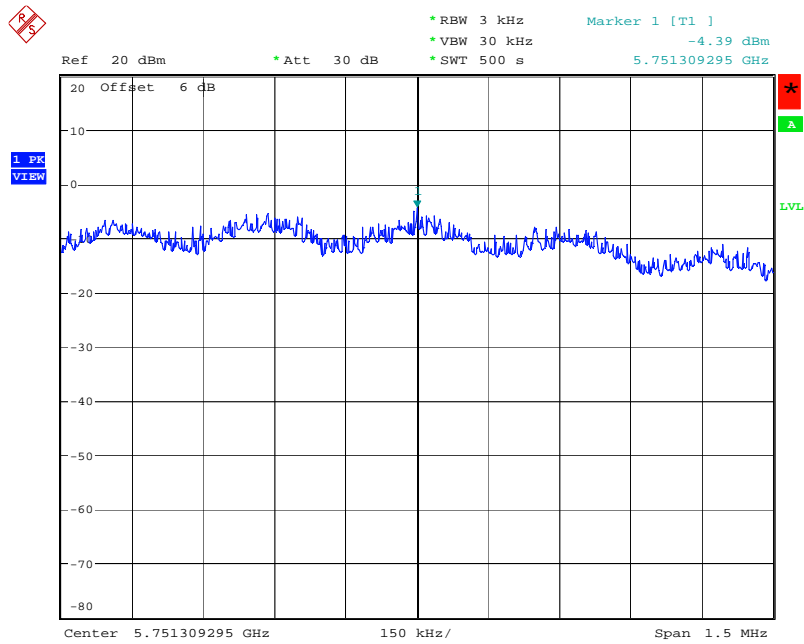

Date: 1.DEC.2007 09:52:58

Power Density Plot on Configuration 11a Draft n MCS8 20MHz Ant. 3+Ant. 5 / 5785 MHz

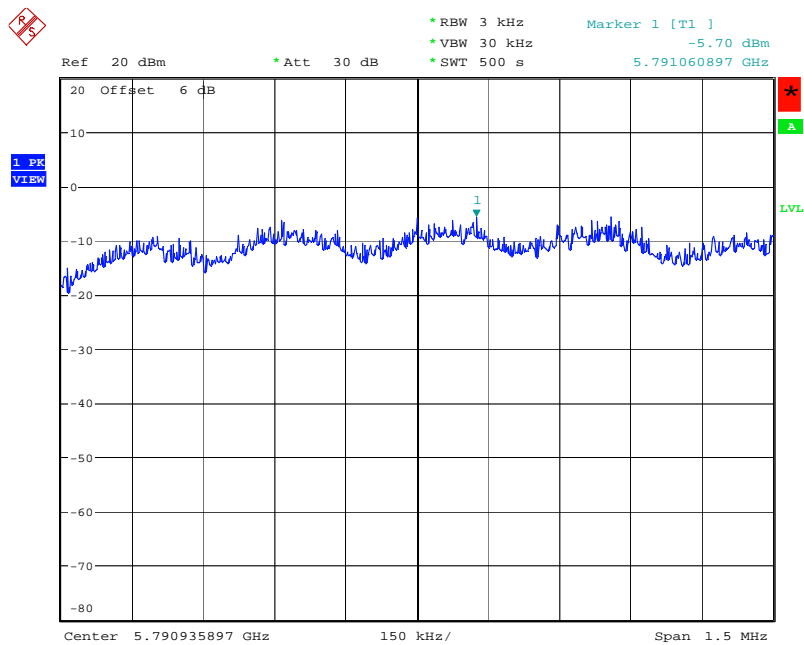

Date: 1.DEC.2007 09:50:37

Power Density Plot on Configuration 11a Draft n MCS8 20MHz Ant. 3+Ant. 5 / 5825 MHz

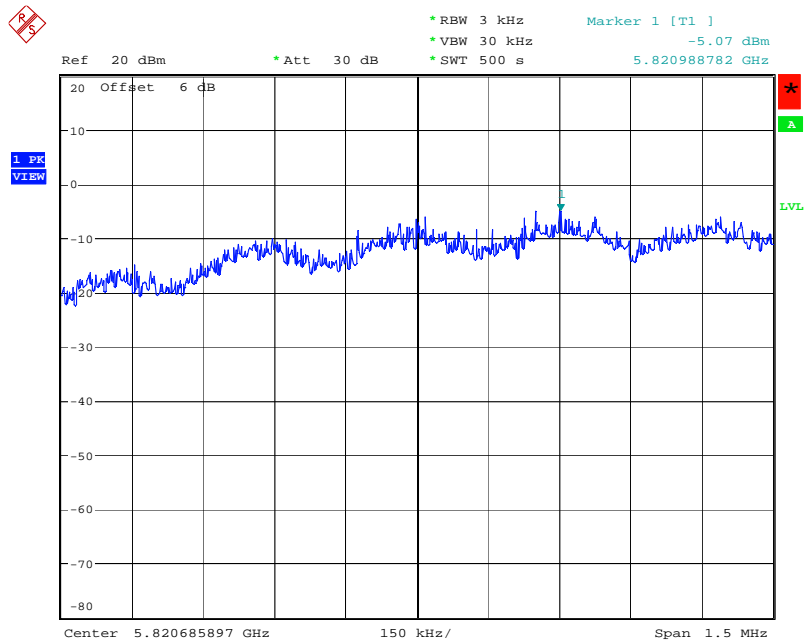

Date: 1.DEC.2007 09:55:54

Power Density Plot on Configuration 11a Draft n MCS8 40MHz Ant. 3+Ant. 5 / 5755MHz

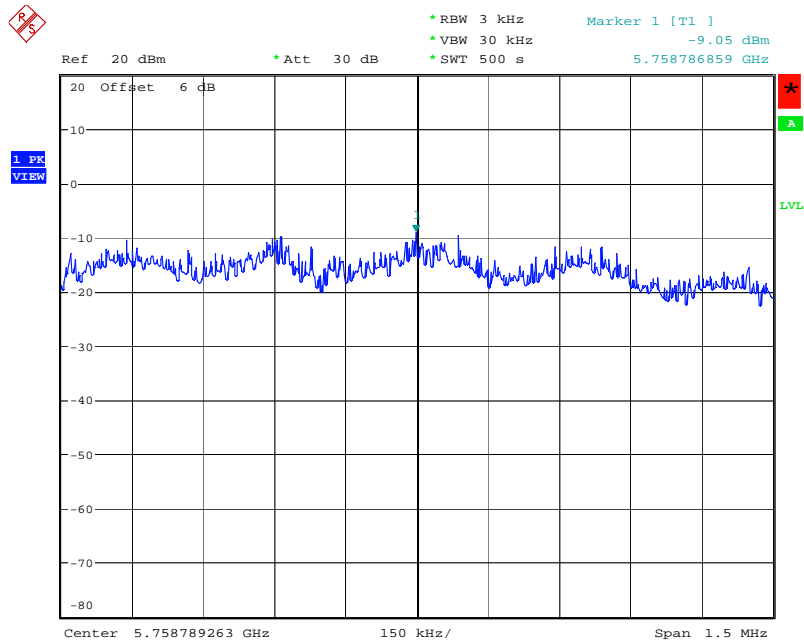

Date: 3.DEC.2007 12:32:13

4.4. 6dB Spectrum Bandwidth Measurement

4.4.1. Limit

For digital modulation systems, the minimum 6 dB bandwidth shall be at least 500 kHz.

4.4.2. Measuring Instruments and Setting

Please refer to section 5 of equipments list in this report. The following table is the setting of the Spectrum Analyzer.

Spectrum Parameters	Setting
Attenuation	Auto
Span Frequency	> 6dB Bandwidth
RB	100 kHz
VB	100 kHz
Detector	Peak
Trace	Max Hold
Sweep Time	Auto

4.4.3. Test Procedures

1. The transmitter output (antenna port) was connected to the spectrum analyser in peak hold mode.
2. The resolution bandwidth of 100 kHz and the video bandwidth of 100 kHz were used.
3. Measured the spectrum width with power higher than 6dB below carrier.
4. Measuring multiple antennas, the connector is required to link with Power Meter through a combiner.

4.4.4. Test Setup Layout

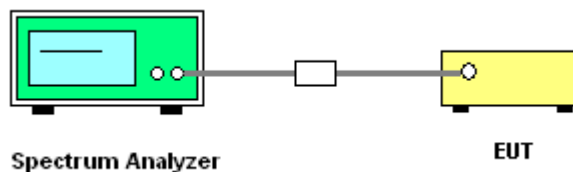

4.4.5. Test Deviation

There is no deviation with the original standard.

4.4.6. EUT Operation during Test

The EUT was programmed to be in continuously transmitting mode.

4.4.7. Test Result of 6dB Spectrum Bandwidth

Temperature	23°C	Humidity	56%
Test Engineer	Barry Chen	Configurations	Draft n

Configuration Draft n MCS8 20MHz Ant. 3 + Ant. 5

Channel	Frequency	6dB Bandwidth (MHz)	99% Occupied Bandwidth (MHz)	Min. Limit (kHz)	Test Result
1	2412 MHz	15.54	17.59	500	Complies
6	2437 MHz	15.54	17.59	500	Complies
11	2462 MHz	15.64	16.69	500	Complies

Configuration Draft n MCS8 40MHz Ant. 3 + Ant. 5

Channel	Frequency	6dB Bandwidth (MHz)	99% Occupied Bandwidth (MHz)	Min. Limit (kHz)	Test Result
3	2422 MHz	35.12	35.89	500	Complies
6	2437 MHz	35.38	36.02	500	Complies
9	2452 MHz	35.12	36.02	500	Complies

Temperature	23°C	Humidity	56%
Test Engineer	Barry Chen	Configurations	11a Draft n

Configuration 11a Draft n MCS8 20MHz Ant. 3+Ant. 5

Channel	Frequency	6dB Bandwidth (MHz)	99% Occupied Bandwidth (MHz)	Min. Limit (kHz)	Test Result
149	5745 MHz	15.32	17.62	500	Complies
157	5785 MHz	15.44	17.62	500	Complies
165	5825 MHz	15.48	17.62	500	Complies

Configuration 11a Draft n MCS8 40MHz Ant. 3+Ant. 5

Channel	Frequency	6dB Bandwidth (MHz)	99% Occupied Bandwidth (MHz)	Min. Limit (kHz)	Test Result
151	5755 MHz	32.56	35.57	500	Complies
159	5795 MHz	32.69	35.51	500	Complies

6 dB Bandwidth Plot on Configuration Draft n MCS8 20MHz Ant. 3 + Ant. 5 / 2412 MHz

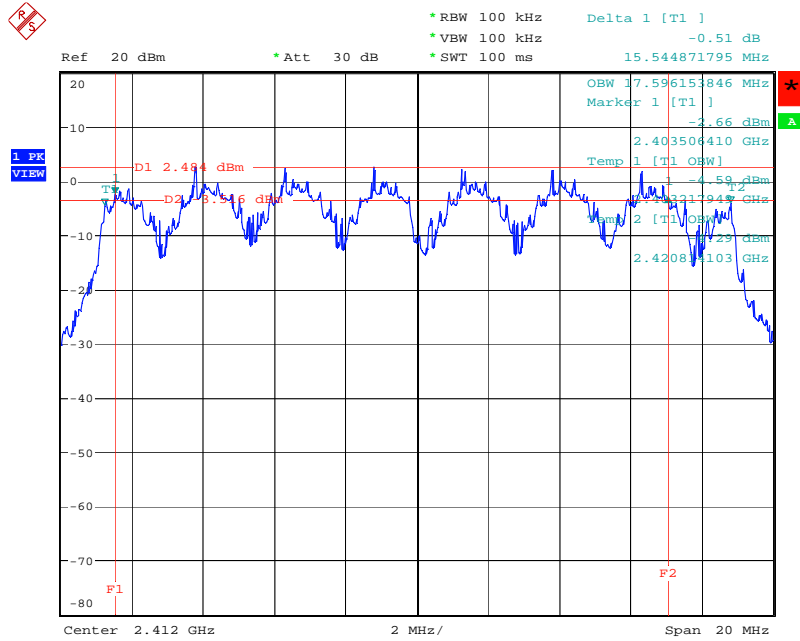

Date: 11.DEC.2007 09:52:00

6 dB Bandwidth Plot on Configuration Draft n MCS8 20MHz Ant. 3 + Ant. 5 / 2437 MHz

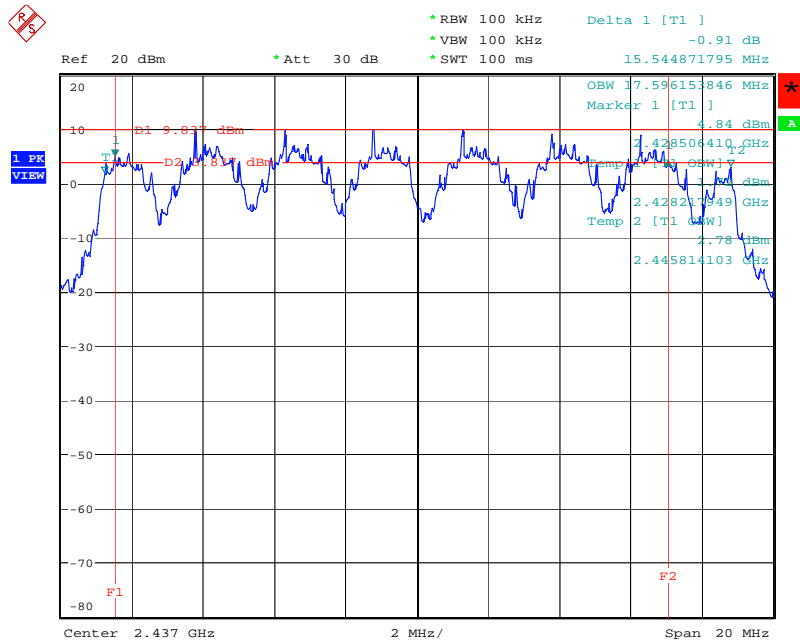

Date: 11.DEC.2007 10:41:09

6 dB Bandwidth Plot on Configuration Draft n MCS8 20MHz Ant. 3 + Ant. 5 / 2462 MHz

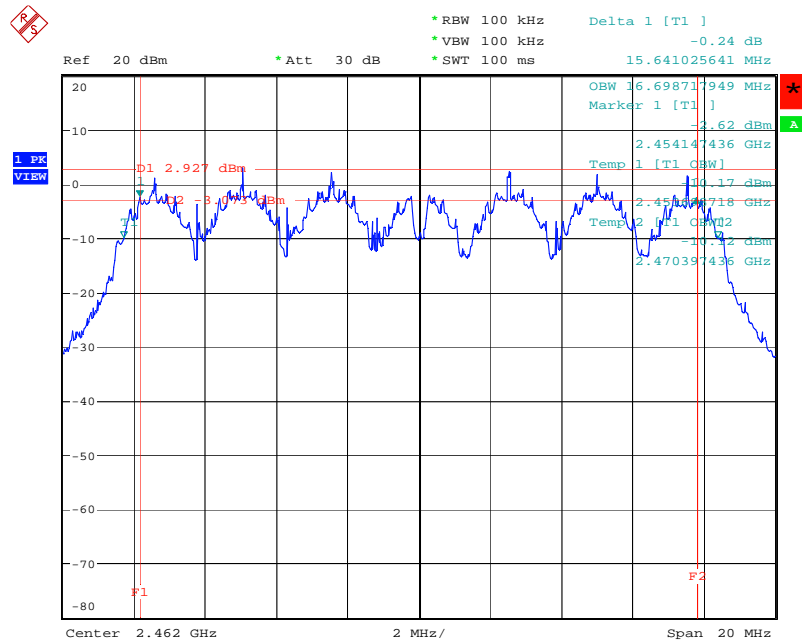

Date: 1.DEC.2007 09:33:28

6 dB Bandwidth Plot on Configuration Draft n MCS8 40MHz Ant. 3 + Ant. 5 / 2422 MHz

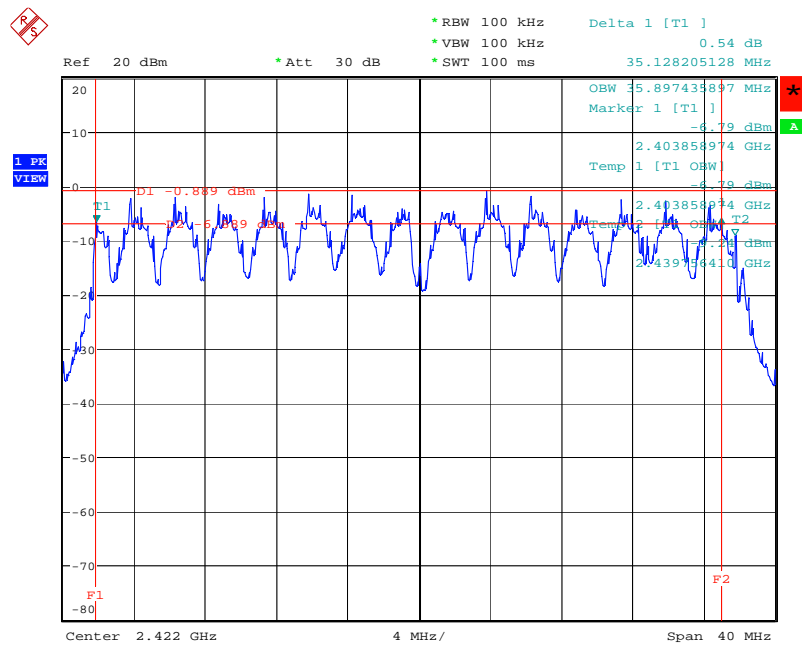

Date: 11.DEC.2007 10:53:05

6 dB Bandwidth Plot on Configuration Draft n MCS8 40MHz Ant. 3 + Ant. 5 / 2437 MHz

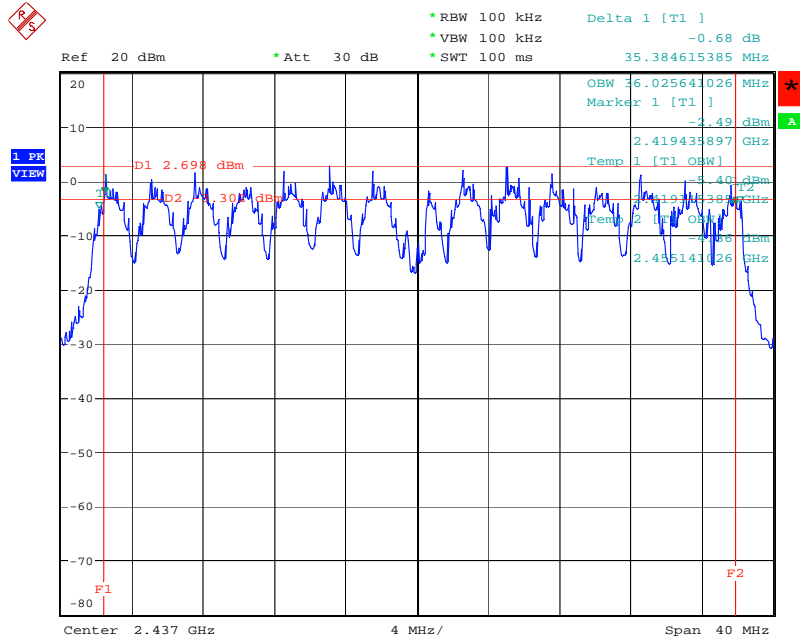

Date: 11.DEC.2007 10:54:53

6 dB Bandwidth Plot on Configuration Draft n MCS8 40MHz Ant. 3 + Ant. 5 / 2452 MHz

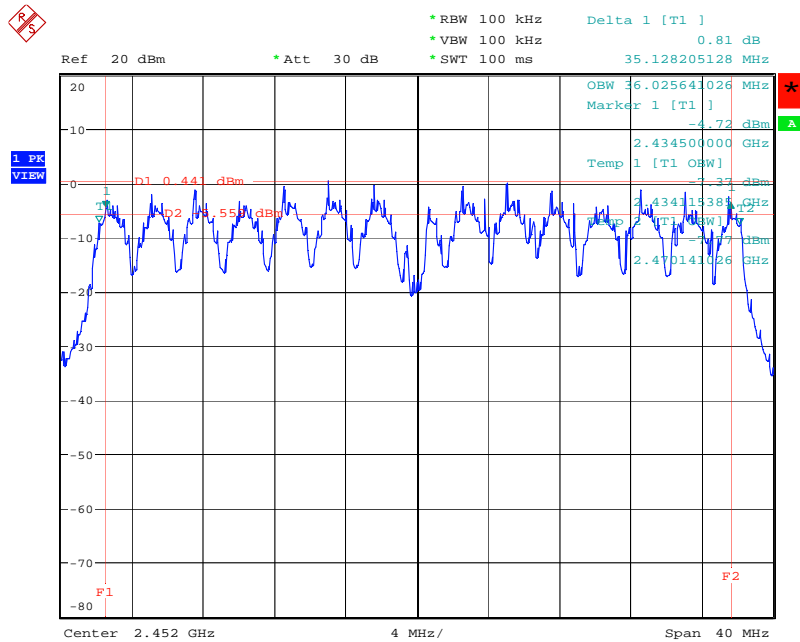

Date: 11.DEC.2007 10:58:30

6 dB Bandwidth Plot on Configuration 11a Draft n MCS8 20MHz Ant. 3+Ant. 5 / 5745 MHz

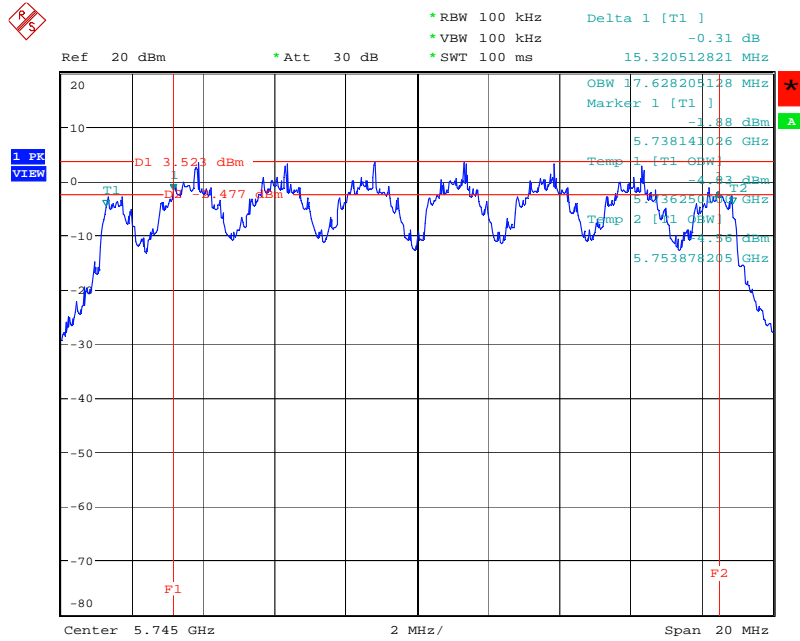

Date: 1.DEC.2007 09:52:33

6 dB Bandwidth Plot on Configuration 11a Draft n MCS8 20MHz Ant. 3+Ant. 5 / 5785MHz

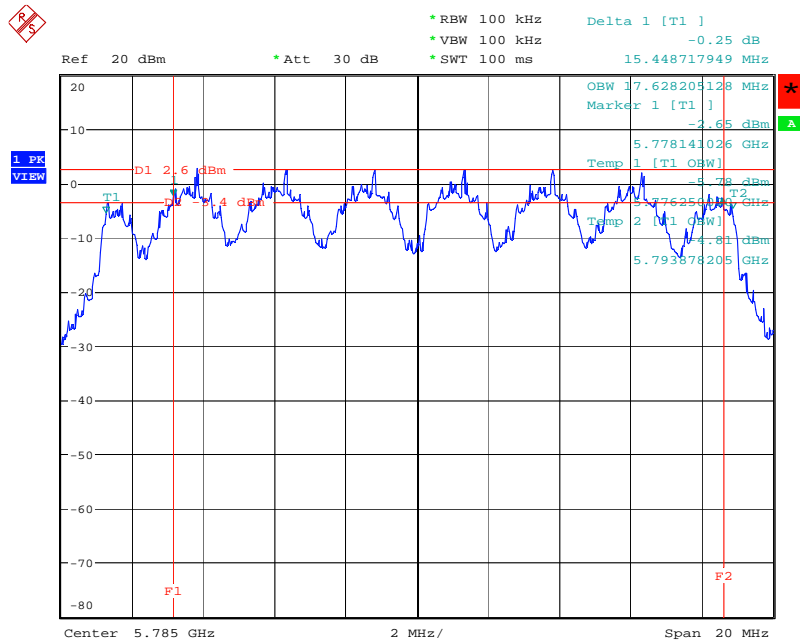

Date: 1.DEC.2007 09:50:11

6 dB Bandwidth Plot on Configuration 11a Drafft n MCS8 20MHz Ant. 3+Ant. 5 / 5825 MHz

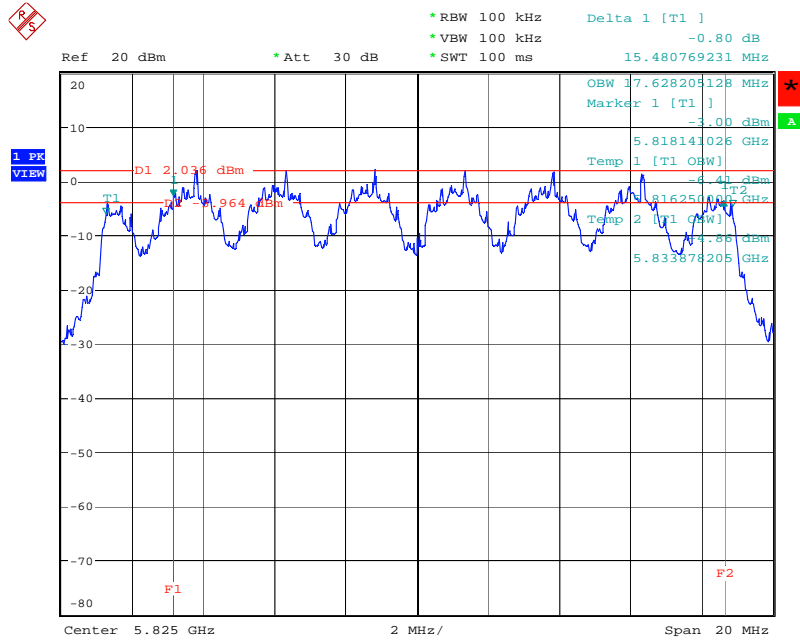

Date: 1.DEC.2007 09:55:28

6 dB Bandwidth Plot on Configuration 11a Drafft n MCS8 40MHz Ant. 3+Ant. 5 / 5755MHz

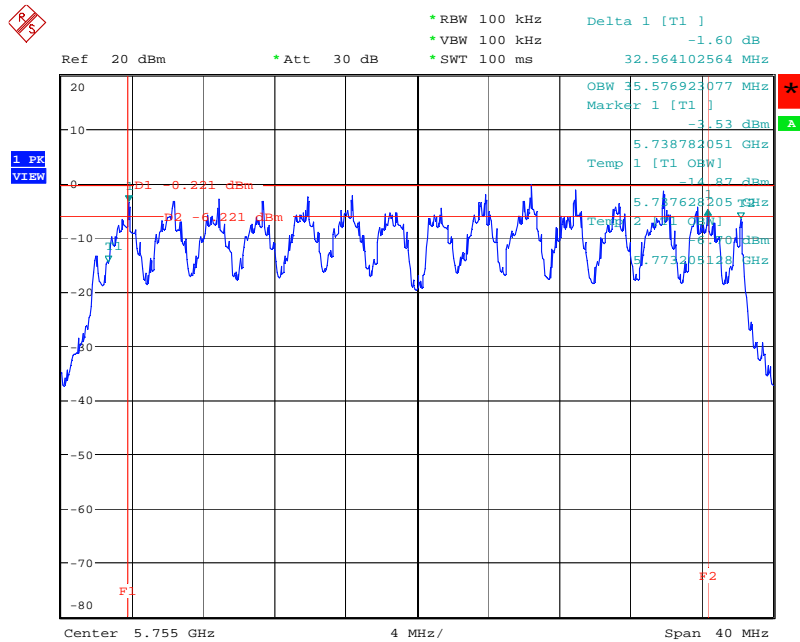

Date: 3.DEC.2007 12:31:47

6 dB Bandwidth Plot on Configuration 11a Draft n MCS8 40MHz Ant. 3+Ant. 5 / 5795 MHz

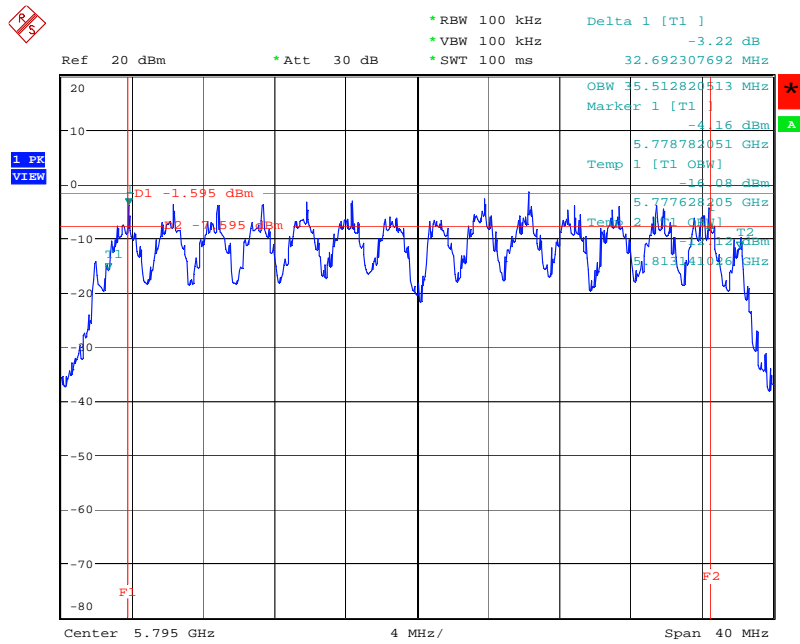

Date: 3.DEC.2007 12:33:25

4.5. Radiated Emissions Measurement

4.5.1. Limit

20dBc in any 100 kHz bandwidth outside the operating frequency band. In case the emission fall within the restricted band specified on 15.205(a), then the 15.209(a) limit in the table below has to be followed.

Frequencies (MHz)	Field Strength (micorvolts/meter)	Measurement Distance (meters)
0.009~0.490	2400/F(KHz)	300
0.490~1.705	24000/F(KHz)	30
1.705~30.0	30	30
30~88	100	3
88~216	150	3
216~960	200	3
Above 960	500	3

4.5.2. Measuring Instruments and Setting

Please refer to section 5 of equipments list in this report. The following table is the setting of spectrum analyzer and receiver.

Spectrum Parameter	Setting
Attenuation	Auto
Start Frequency	1000 MHz
Stop Frequency	10th carrier harmonic
RB / VB (Emission in restricted band)	1MHz / 1MHz for Peak, 1 MHz / 10Hz for Average
RB / VB (Emission in non-restricted band)	1000KHz / 1000KHz for peak

Receiver Parameter	Setting
Attenuation	Auto
Start ~ Stop Frequency	9kHz~150kHz / RB 200Hz for QP
Start ~ Stop Frequency	150kHz~30MHz / RB 9kHz for QP
Start ~ Stop Frequency	30MHz~1000MHz / RB 120kHz for QP

4.5.3. Test Procedures

1. Configure the EUT according to ANSI C63.4. The EUT was placed on the top of the turntable 0.8 meter above ground. The phase center of the receiving antenna mounted on the top of a height-variable antenna tower was placed 3 meters far away from the turntable.
2. Power on the EUT and all the supporting units. The turntable was rotated by 360 degrees to determine the position of the highest radiation.
3. The height of the broadband receiving antenna was varied between one meter and four meters above ground to find the maximum emissions field strength of both horizontal and vertical polarization.
4. For each suspected emissions, the antenna tower was scan (from 1 m to 4 m) and then the turntable was rotated (from 0 degree to 360 degrees) to find the maximum reading.
5. Set the test-receiver system to Peak or CISPR quasi-peak Detect Function with specified bandwidth under Maximum Hold Mode.
6. For emissions above 1GHz, use 1MHz VBW and RBW for peak reading. Then 1MHz RBW and 10Hz VBW for average reading in spectrum analyzer.
7. When the radiated emissions limits are expressed in terms of the average value of the emissions, and pulsed operation is employed, the measurement field strength shall be determined by averaging over one complete pulse train, including blanking intervals, as long as the pulse train does not exceed 0.1 seconds. As an alternative (provided the transmitter operates for longer than 0.1 seconds) or in cases where the pulse train exceeds 0.1 seconds, the measured field strength shall be determined from the average absolute voltage during a 0.1 second interval during which the field strength is at its maximum value.
8. If the emissions level of the EUT in peak mode was 3 dB lower than the average limit specified, then testing will be stopped and peak values of EUT will be reported, otherwise, the emissions which do not have 3 dB margin will be repeated one by one using the quasi-peak method for below 1GHz.
9. For testing above 1GHz, the emissions level of the EUT in peak mode was lower than average limit (that means the emissions level in peak mode also complies with the limit in average mode), then testing will be stopped and peak values of EUT will be reported, otherwise, the emissions will be measured in average mode again and reported.
10. In case the emission is lower than 30MHz, loop antenna has to be used for measurement and the recorded data should be QP measured by receiver. High – Low scan is not required in this case.

4.5.4. Test Setup Layout

For radiated emissions below 30MHz

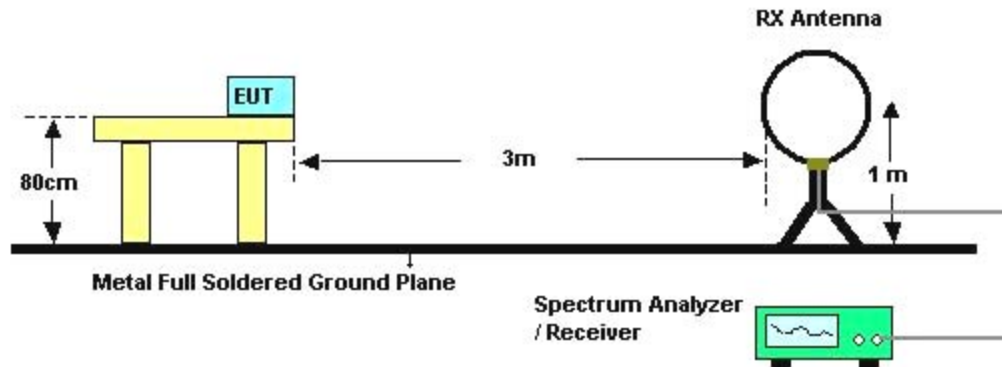

For radiated emissions above 30MHz

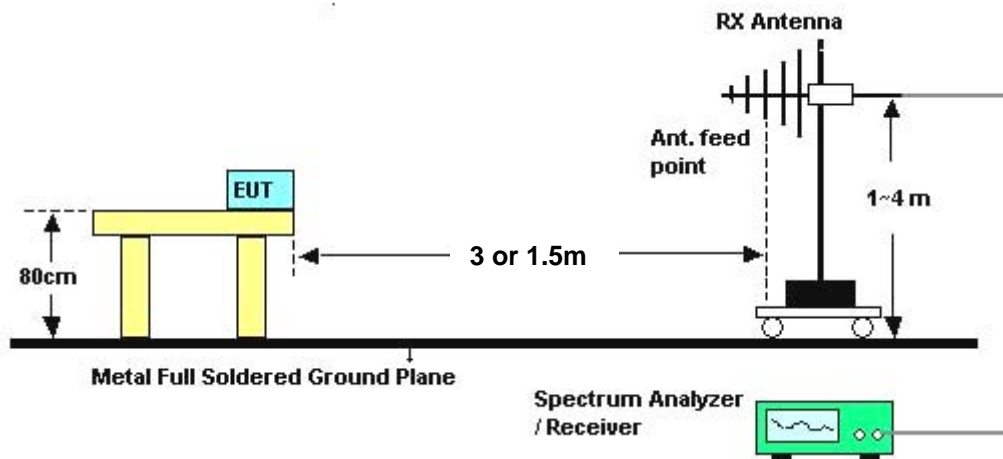

Above 10 GHz shall be extrapolated to the specified distance using an extrapolation factor of 20 dB/decade from 3m to 1.5m.

Distance extrapolation factor = $20 \log (\text{specific distance [3m]} / \text{test distance [1.5m]})$ (dB);

Limit line = specific limits (dBuV) + distance extrapolation factor [6 dB].

4.5.5. Test Deviation

There is no deviation with the original standard.

4.5.6. EUT Operation during Test

The EUT was programmed to be in continuously transmitting mode.

4.5.7. Results of Radiated Emissions (9kHz~30MHz)

Temperature	23°C	Humidity	54%
Test Engineer	Barry Chen	Configurations	Normal Link

Freq. (MHz)	Level (dBuV)	Over Limit (dB)	Limit Line (dBuV)	Remark
-	-	-	-	See Note

Note:

The amplitude of spurious emissions which are attenuated by more than 20 dB below the permissible value has no need to be reported.

Distance extrapolation factor = $40 \log(\text{specific distance} / \text{test distance})$ (dB);

Limit line = specific limits (dBuV) + distance extrapolation factor.

4.5.8. Results of Radiated Emissions (30MHz~1GHz)

Temperature	23°C	Humidity	54%
Test Engineer	Barry Chen	Configurations	Normal Link

Horizontal

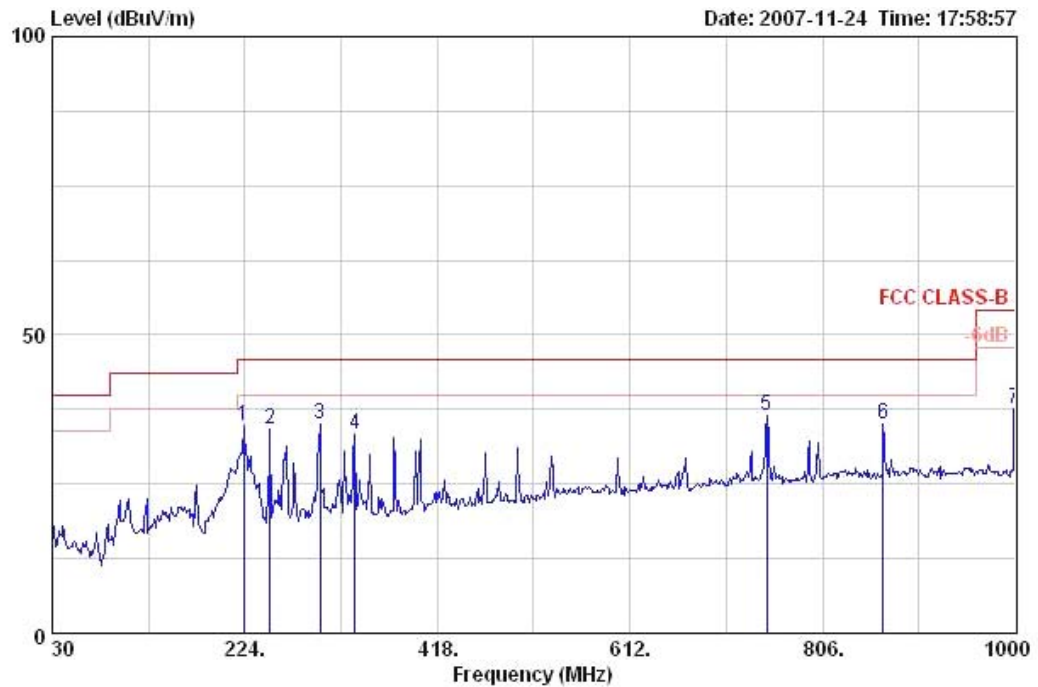

	Freq	Level	Over Limit	Limit Line	Read Level	Antenna Factor	Preamp Factor	Cable Loss	Remark	Table Pos	Ant Pos	Pol/Phase
	MHz	dBuV/m	dB	dBuV/m	dBuV	dB/m	dB	dB		deg	cm	
1	223.030	34.71	-11.29	46.00	51.06	8.91	27.05	1.79	Peak	0	100	HORIZONTAL
2	249.220	34.07	-11.93	46.00	47.61	11.56	27.00	1.90	Peak	0	100	HORIZONTAL
3	299.660	35.16	-10.84	46.00	47.06	12.90	26.90	2.10	Peak	0	100	HORIZONTAL
4	334.580	33.41	-12.59	46.00	44.42	13.97	27.14	2.17	Peak	0	100	HORIZONTAL
5	749.740	36.59	-9.41	46.00	40.82	20.07	27.80	3.50	Peak	0	100	HORIZONTAL
6	867.110	34.93	-11.07	46.00	38.51	20.43	27.47	3.47	Peak	0	100	HORIZONTAL
7	1000.000	37.69	-16.31	54.00	40.69	20.30	27.00	3.70	Peak	0	100	HORIZONTAL

Vertical

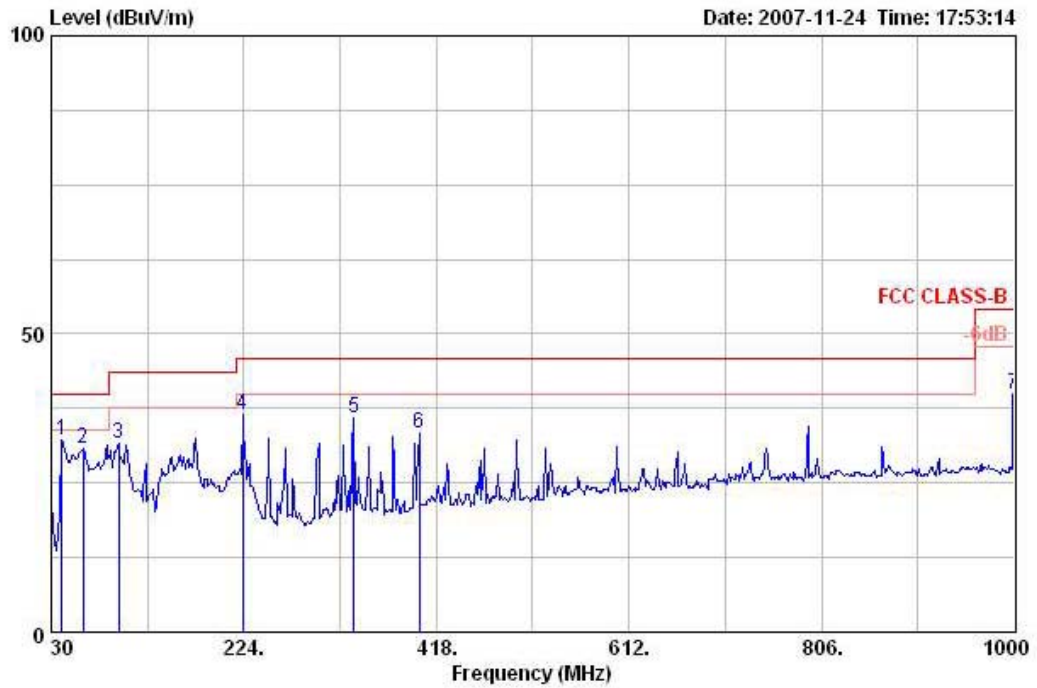

	Freq	Level	Over	Limit	Read	Antenna	Preamp	Cable	Table	Ant
	MHz	dBuV/m	Limit	Line	Level	Factor	Factor	Loss	Pos	Pos
			dB	dBuV/m	dBuV	dB/m	dB	dB	deg	cm
1	40.670	32.06	-7.94	40.00	47.71	11.45	27.80	0.70	236	100
2	62.010	30.68	-9.32	40.00	52.64	4.95	27.75	0.84	0	400
3	97.900	31.70	-11.80	43.50	48.20	9.95	27.61	1.16	0	400
4	223.030	36.59	-9.41	46.00	52.94	8.91	27.05	1.79	0	400
5	334.580	35.79	-10.21	46.00	46.80	13.97	27.14	2.17	0	400
6	400.540	33.46	-12.54	46.00	42.81	15.95	27.61	2.31	0	400
7	1000.000	39.85	-14.15	54.00	42.85	20.30	27.00	3.70	0	400

Note:

The amplitude of spurious emissions which are attenuated by more than 20 dB below the permissible value has no need to be reported.

Emission level (dBuV/m) = 20 log Emission level (uV/m).

Corrected Reading: Antenna Factor + Cable Loss + Read Level - Preamp Factor = Level.

4.5.9. Results for Radiated Emissions (1GHz~10th Harmonic)

Temperature	23°C	Humidity	54%
Test Engineer	Barry Chen	Configurations	Draft n MCS8 20MHz Ch 1 Ant. 3 + Ant. 5

Horizontal

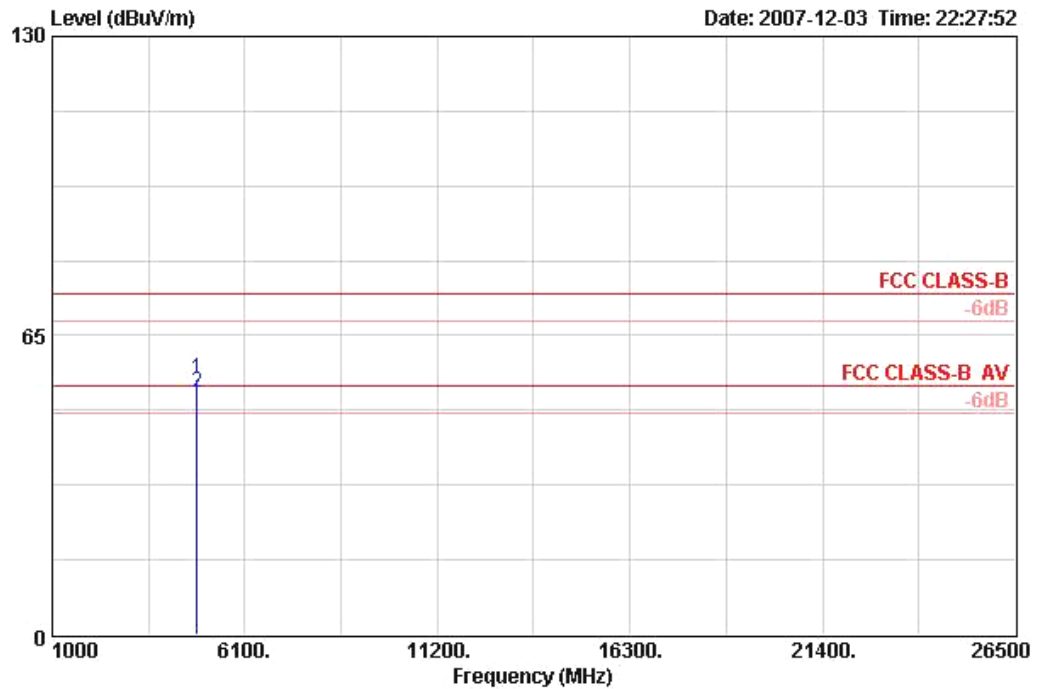

	Freq	Level	Over Limit	Limit Line	Remark	Pol/Phase	Distance	ReadAntenna Level	Antenna Factor	Cable Loss	Preamp Factor
	MHz	dBUV/m	dB	dBUV/m			m	dBuV	dB/m	dB	dB
1	4824.020	55.61	-18.39	74.00	PEAK	HORIZONTAL	3	51.32	33.06	6.40	35.16
2 !	4824.060	52.43	-1.57	54.00	AVERAGE	HORIZONTAL	3	48.14	33.06	6.40	35.16

Vertical

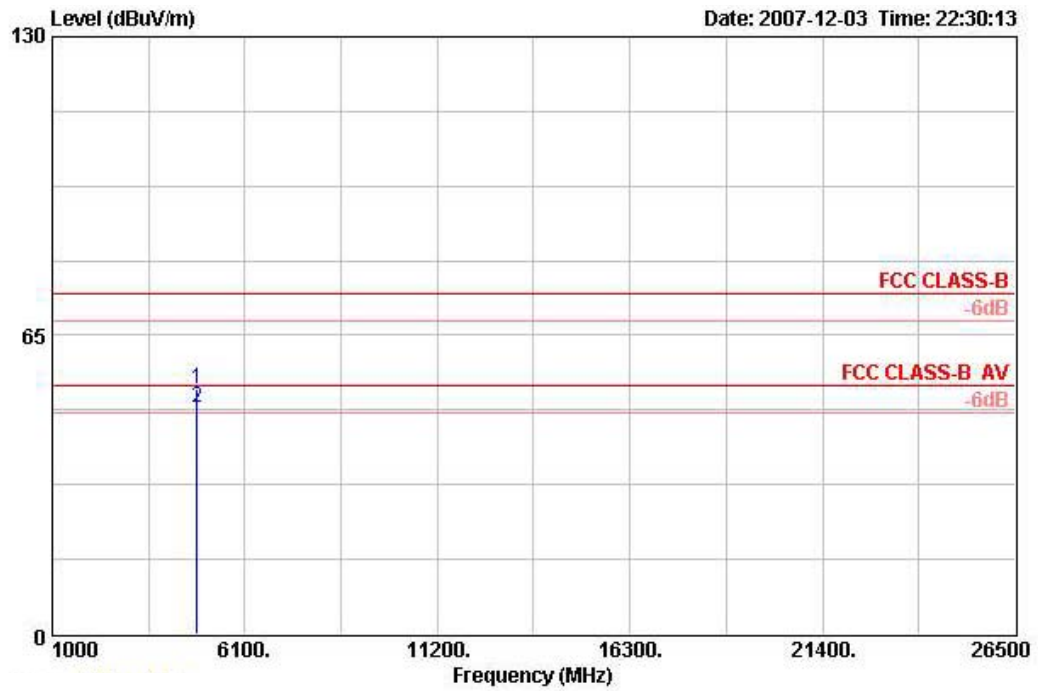

	Freq	Level	Over Limit	Limit	Line Remark	Pol/Phase	Distance	Read Antenna Level	Antenna Factor	Cable Loss	Preamp Factor
	MHz	dBuV/m	dB	dBuV/m			m	dBuV	dB/m	dB	dB
1	4824.000	53.40	-20.60	74.00	PEAK	VERTICAL	3	49.11	33.06	6.40	35.16
2 !	4824.040	49.19	-4.81	54.00	AVERAGE	VERTICAL	3	44.90	33.06	6.40	35.16

Temperature	23°C	Humidity	54%
Test Engineer	Barry Chen	Configurations	Draft n MCS8 20MHz Ch 6 Ant. 3 + Ant. 5

Horizontal

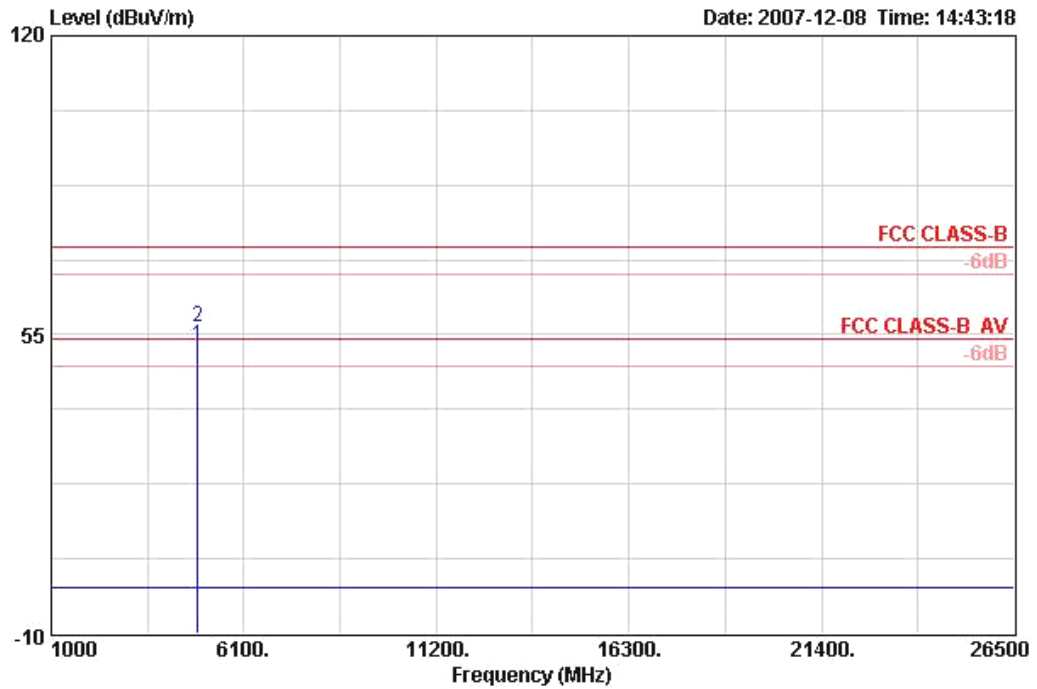

	Freq	Level	Over Limit	Limit Line	Remark	Pol/Phase	Distance	ReadAntenna Level	Antenna Factor	Cable Loss	Preamp Factor
	MHz	dBuV/m	dB	dBuV/m			m	dBuV	dB/m	dB	dB
1 !	4874.070	52.77	-1.23	54.00	AVERAGE	HORIZONTAL	3	48.35	33.16	6.42	35.15
2	4874.090	56.55	-17.45	74.00	PEAK	HORIZONTAL	3	52.12	33.16	6.42	35.15

Vertical

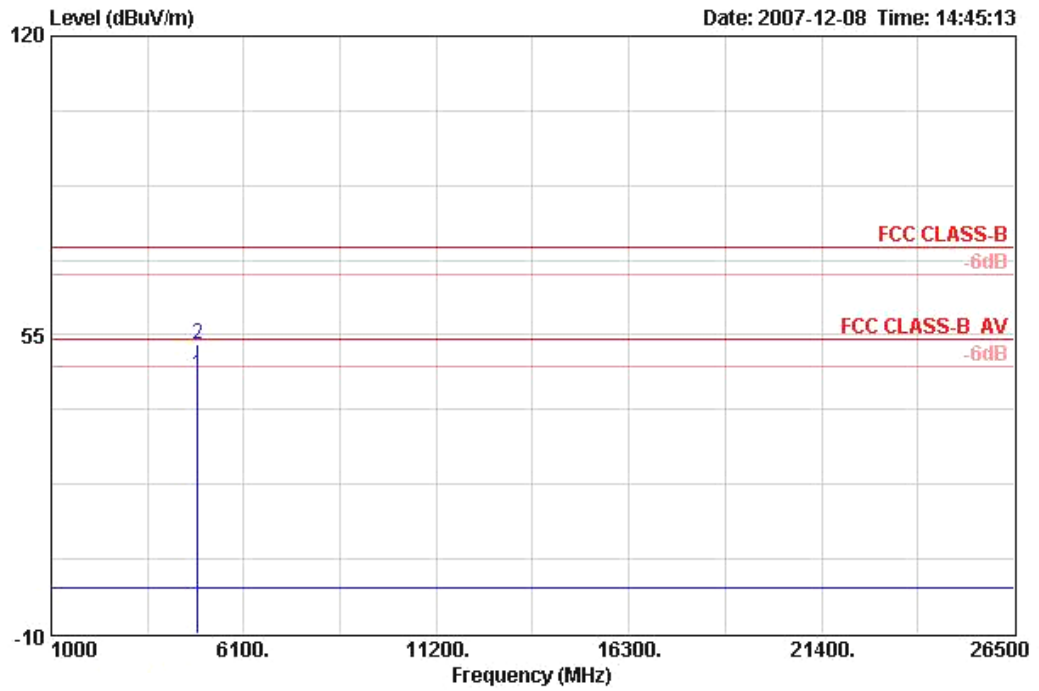

	Freq	Level	Over Limit	Limit	Line	Remark	Pol/Phase	Distance	ReadAntenna	Cable	Preamp
	MHz	dBuV/m	dB	dBuV/m				m	dBuV	dB/m	dB
1	4874.050	46.34	-7.66	54.00	AVERAGE	VERTICAL		3	41.91	33.16	6.42 35.15
2	4874.340	53.11	-20.89	74.00	PEAK	VERTICAL		3	48.69	33.16	6.42 35.15

Temperature	23°C	Humidity	54%
Test Engineer	Barry Chen	Configurations	Draft n MCS8 20MHz Ch11 Ant. 3 + Ant. 5

Horizontal

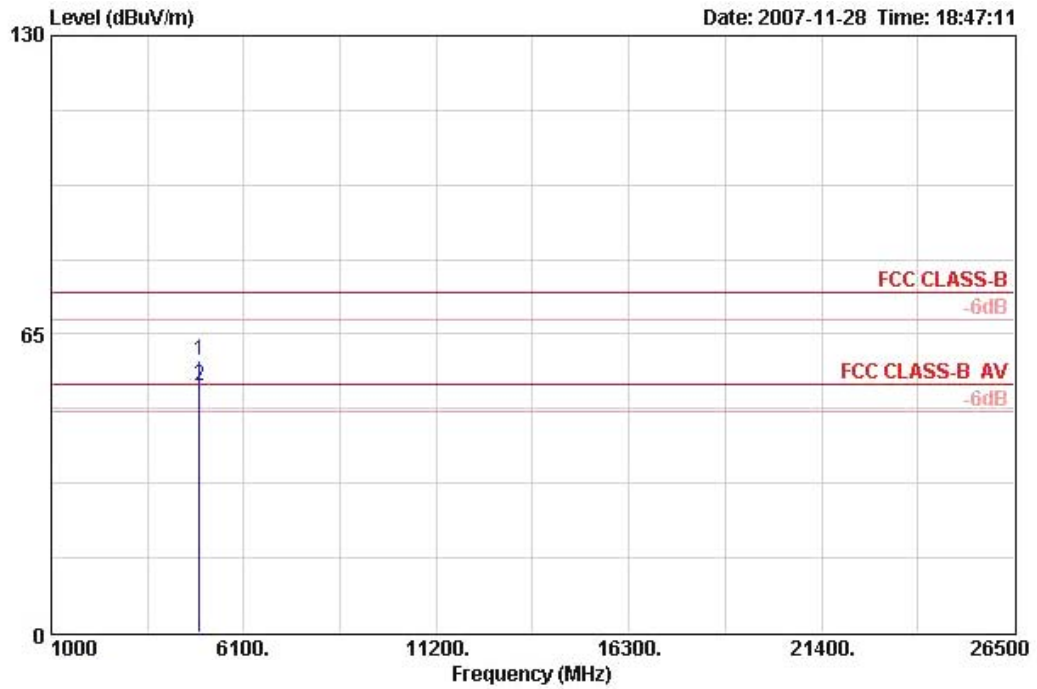

	Freq	Level	Over	Limit	Remark	Pol/Phase	Distance	ReadAntenna		Cable Preamp	
			Limit	Line				Level	Factor	Loss	Factor
	MHz	dBUV/m	dB	dBUV/m			m	dBUV	dB/m	dB	dB
1	4923.910	59.26	-14.74	74.00	PEAK	HORIZONTAL	3	54.70	33.26	6.44	35.14
2	4924.050	53.69	-0.31	54.00	AVERAGE	HORIZONTAL	3	49.13	33.26	6.44	35.14

Vertical

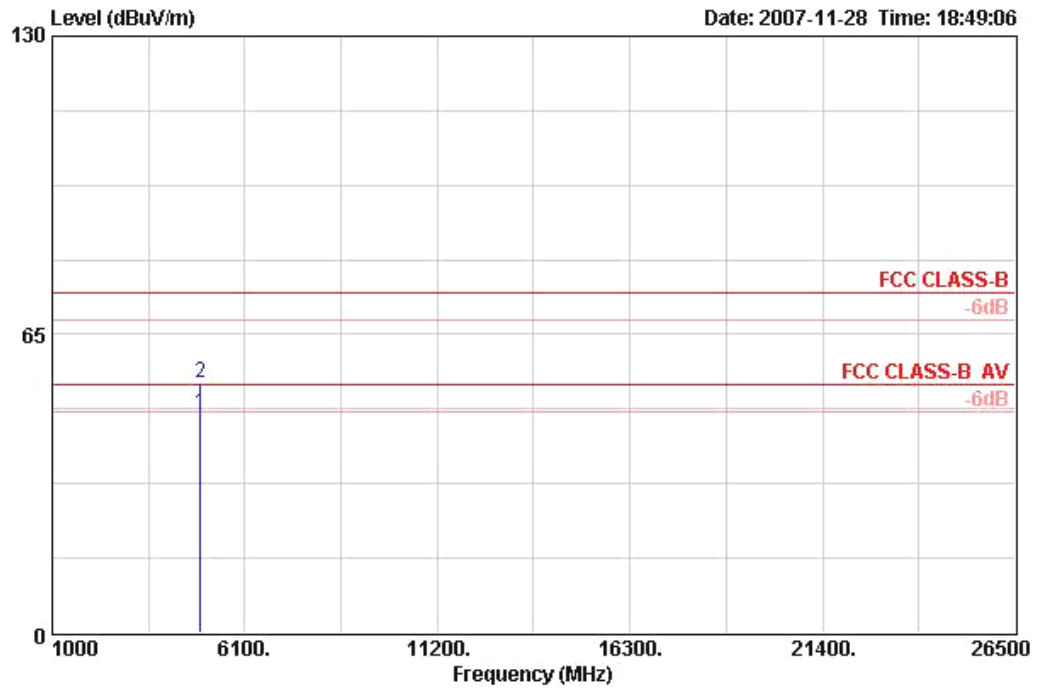

	Freq	Level	Over Limit	Limit Line	Remark	Pol/Phase	Distance	ReadAntenna Level	Antenna Factor	Cable Loss	Preamp Factor
	MHz	dBuV/m	dB	dBuV/m			m	dBuV	dB/m	dB	dB
1	4924.030	47.71	-6.29	54.00	AVERAGE	VERTICAL	3	43.15	33.26	6.44	35.14
2	4924.070	54.30	-19.70	74.00	PEAK	VERTICAL	3	49.75	33.26	6.44	35.14

Temperature	23°C	Humidity	54%
Test Engineer	Barry Chen	Configurations	Draft n MCS8 40MHz Ch 3 Ant. 3 + Ant. 5

Horizontal

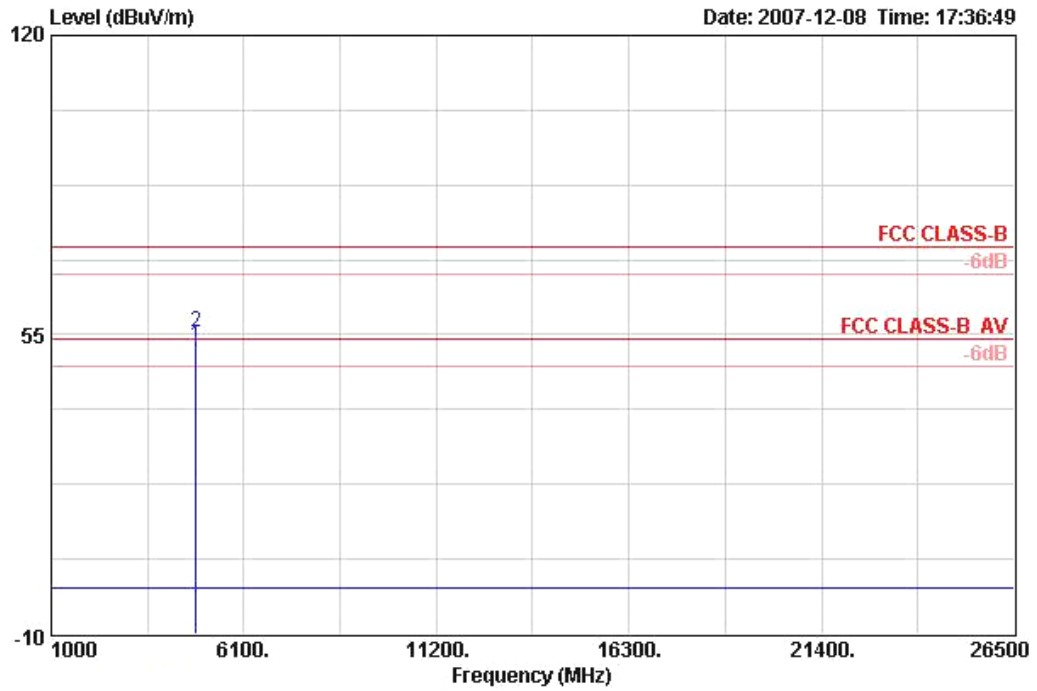

	Freq	Level	Over Limit	Limit	Line	Remark	Pol/Phase	Distance	ReadAntenna	Cable	Preamp
	MHz	dBuV/m	dB	dBuV/m				m	dBuV	dB/m	dB
1 !	4844.050	52.63	-1.37	54.00	AVERAGE	HORIZONTAL		3	48.29	33.09	6.41 35.16
2	4844.080	55.47	-18.53	74.00	PEAK	HORIZONTAL		3	51.13	33.09	6.41 35.16

Vertical

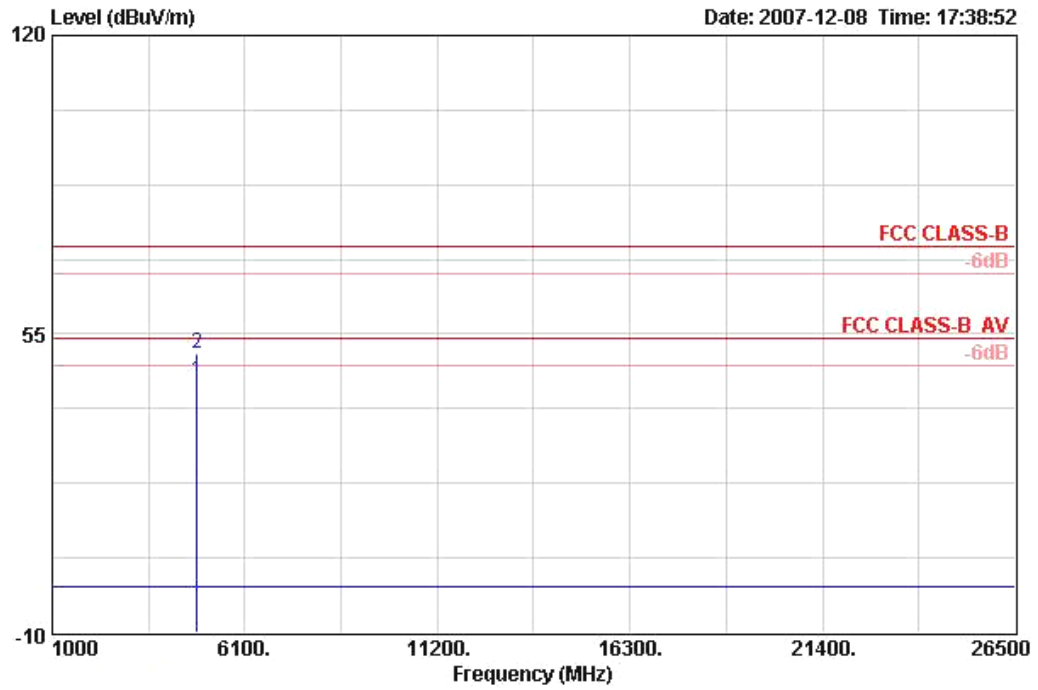

	Freq	Level	Over Limit	Limit Line	Remark	Pol/Phase	Distance	ReadAntenna Level	Antenna Factor	Cable Loss	Preamp Factor
	MHz	dBuV/m	dB	dBuV/m			m	dBuV	dB/m	dB	dB
1	4844.090	44.97	-9.03	54.00	AVERAGE	VERTICAL	3	40.63	33.09	6.41	35.16
2	4844.210	50.84	-23.16	74.00	PEAK	VERTICAL	3	46.50	33.09	6.41	35.16

Temperature	23°C	Humidity	54%
Test Engineer	Barry Chen	Configurations	Draft n MCS8 40MHz Ch 6 Ant. 3 + Ant. 5

Horizontal

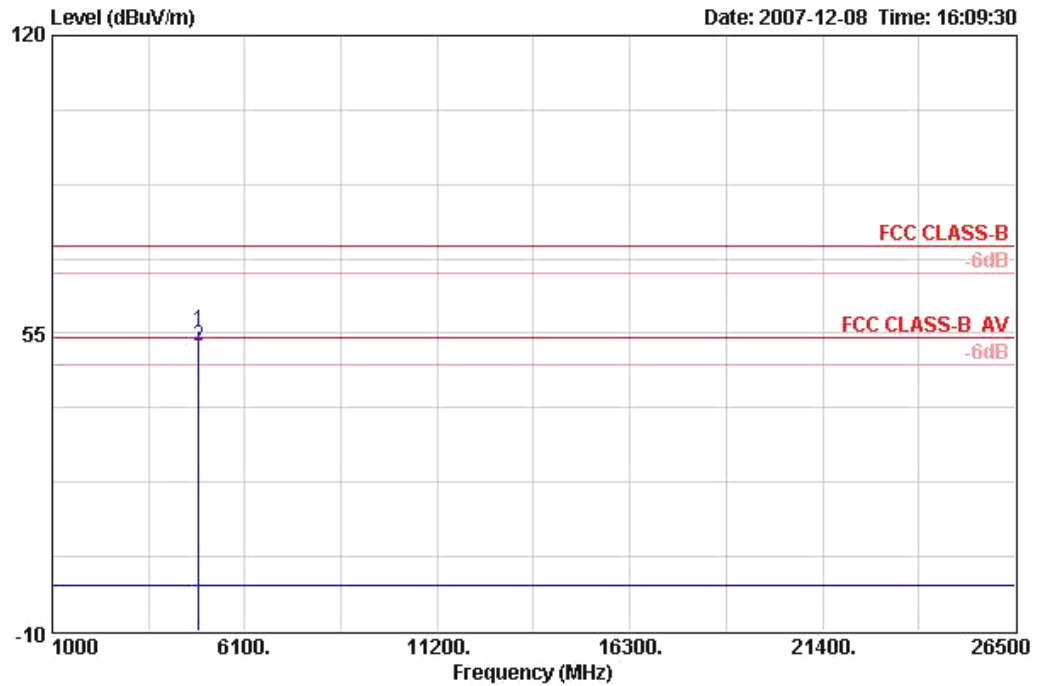

	Freq	Level	Over	Limit	Line Remark	Pol/Phase	Distance	ReadAntenna		Cable Preamp	
			Limit	Line				Level	Factor	Loss	Factor
	MHz	dBuV/m	dB	dBuV/m			m	dBuV	dB/m	dB	dB
1	4874.000	55.73	-18.27	74.00	PEAK	HORIZONTAL	3	51.31	33.16	6.42	35.15
2 !	4874.070	52.23	-1.77	54.00	AVERAGE	HORIZONTAL	3	47.81	33.16	6.42	35.15

Vertical

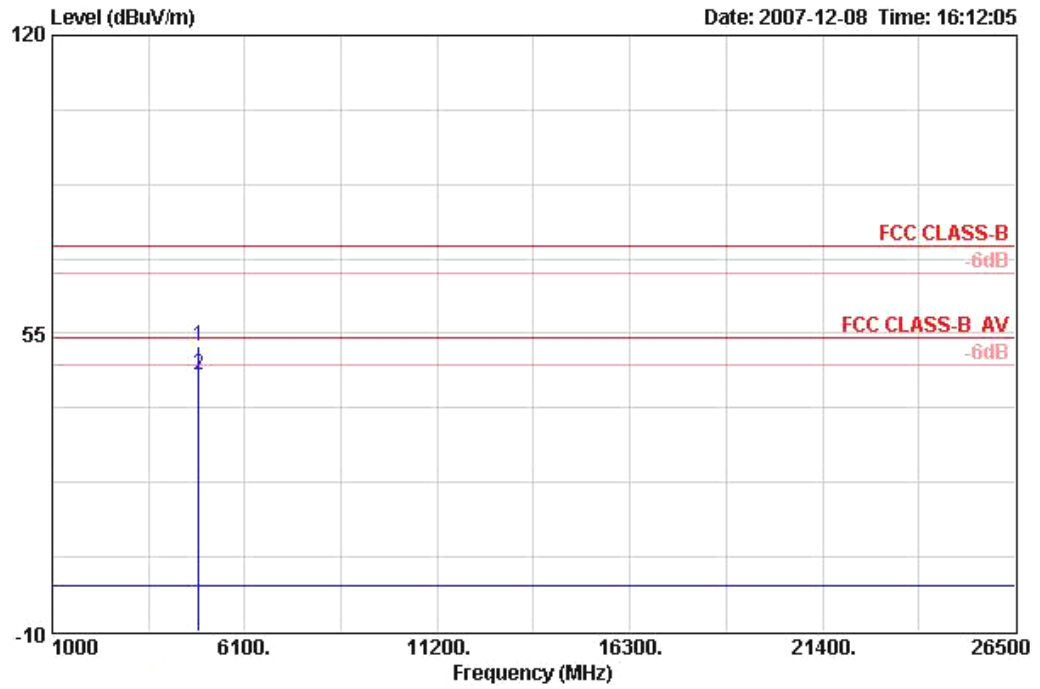

	Freq	Level	Over Limit	Limit	Line	Remark	Pol/Phase	Distance	ReadAntenna	Cable	Preamp
	MHz	dBuV/m	dB	dBuV/m				m	dBuV	dB/m	dB
1	4873.920	52.04	-21.96	74.00	PEAK	VERTICAL		3	47.62	33.16	6.42 35.15
2	4874.052	46.05	-7.95	54.00	AVERAGE	VERTICAL		3	41.62	33.16	6.42 35.15

Temperature	23°C	Humidity	54%
Test Engineer	Barry Chen	Configurations	Draft n MCS8 40MHz Ch 9 Ant. 3 + Ant. 5

Horizontal

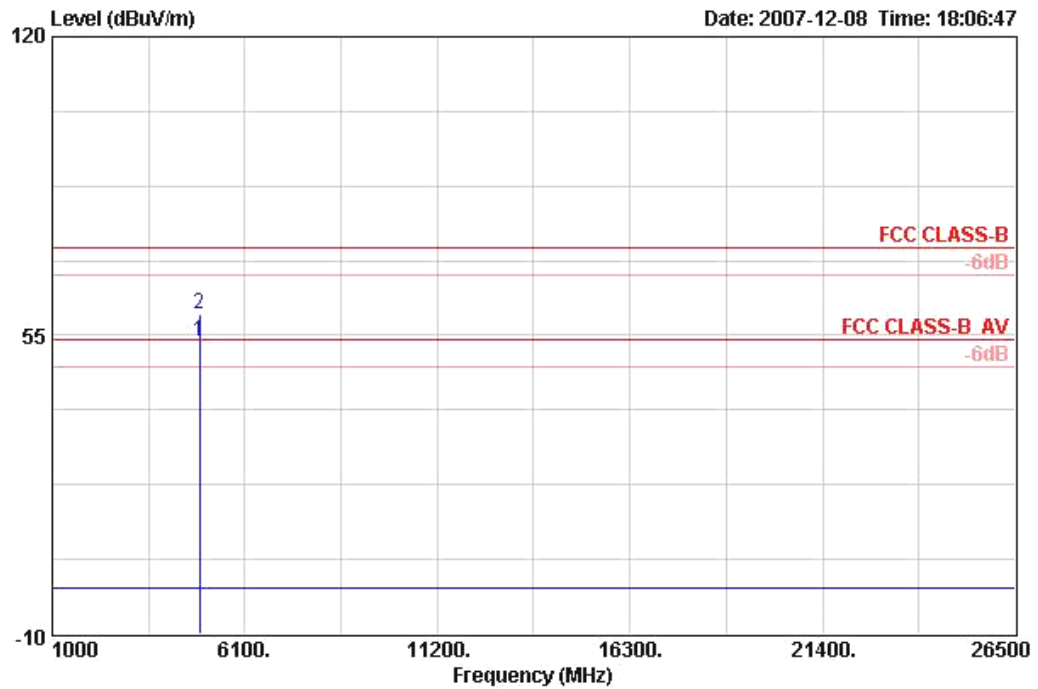

	Freq	Level	Over Limit	Limit Line	Remark	Pol/Phase	Distance	ReadAntenna Level	Antenna Factor	Cable Loss	Preamp Factor
	MHz	dBuV/m	dB	dBuV/m			m	dBuV	dB/m	dB	dB
1	4904.070	53.57	-0.43	54.00	AVERAGE	HORIZONTAL	3	49.06	33.23	6.43	35.15
2	4904.170	59.50	-14.50	74.00	PEAK	HORIZONTAL	3	54.99	33.23	6.43	35.15

Vertical

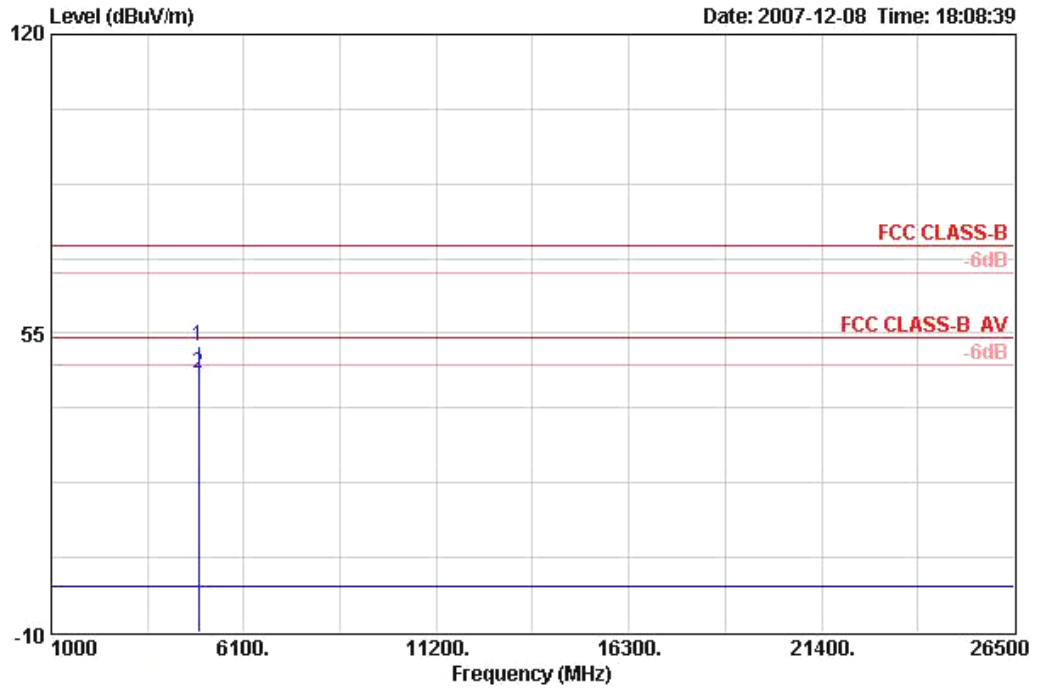

	Freq	Level	Over	Limit	Remark	Pol/Phase	Distance	ReadAntenna		Cable	Preamp
			Limit	Line				Level	Factor	Loss	Factor
	MHz	dBuV/m	dB	dBuV/m			m	dBuV	dB/m	dB	dB
1	4903.990	52.08	-21.92	74.00	PEAK	VERTICAL	3	47.57	33.23	6.43	35.15
2	4904.050	46.22	-7.78	54.00	AVERAGE	VERTICAL	3	41.72	33.23	6.43	35.15

Note:

The amplitude of spurious emissions which are attenuated by more than 20 dB below the permissible value has no need to be reported.

Emission level (dBuV/m) = 20 log Emission level (uV/m).

Corrected Reading: Antenna Factor + Cable Loss + Read Level - Preamp Factor = Level.

Temperature	23°C	Humidity	54%
Test Engineer	Barry Chen	Configurations	11a Draft n MCS8 20MHz CH 149 Ant. 3 + Ant. 5

Horizontal

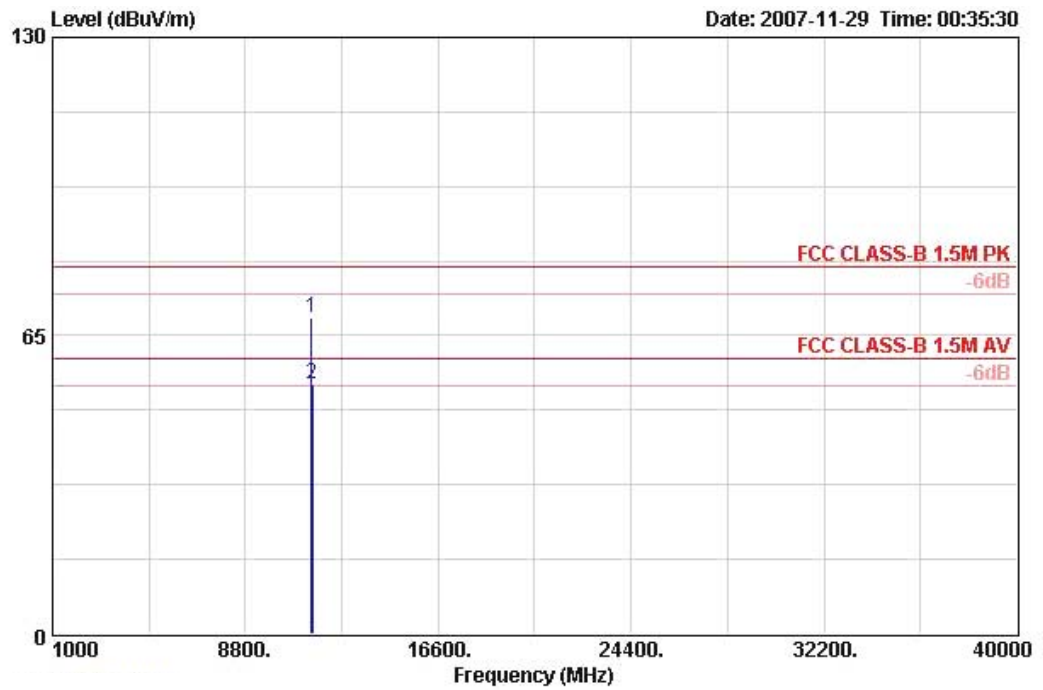

	Freq	Level	Over Limit	Limit	Line	Remark	Pol/Phase	Distance	Read Level	Antenna Factor	Cable Loss	Preamp Factor
	MHz	dBuV/m	dB	dBuV/m				m	dBuV	dB/m	dB	dB
1	11489.040	68.73	-11.27	80.00	PEAK	HORIZONTAL		3	55.15	38.78	9.78	34.98
2 !	11491.080	54.41	-5.59	60.00	AVERAGE	HORIZONTAL		3	40.84	38.78	9.78	34.98

Vertical

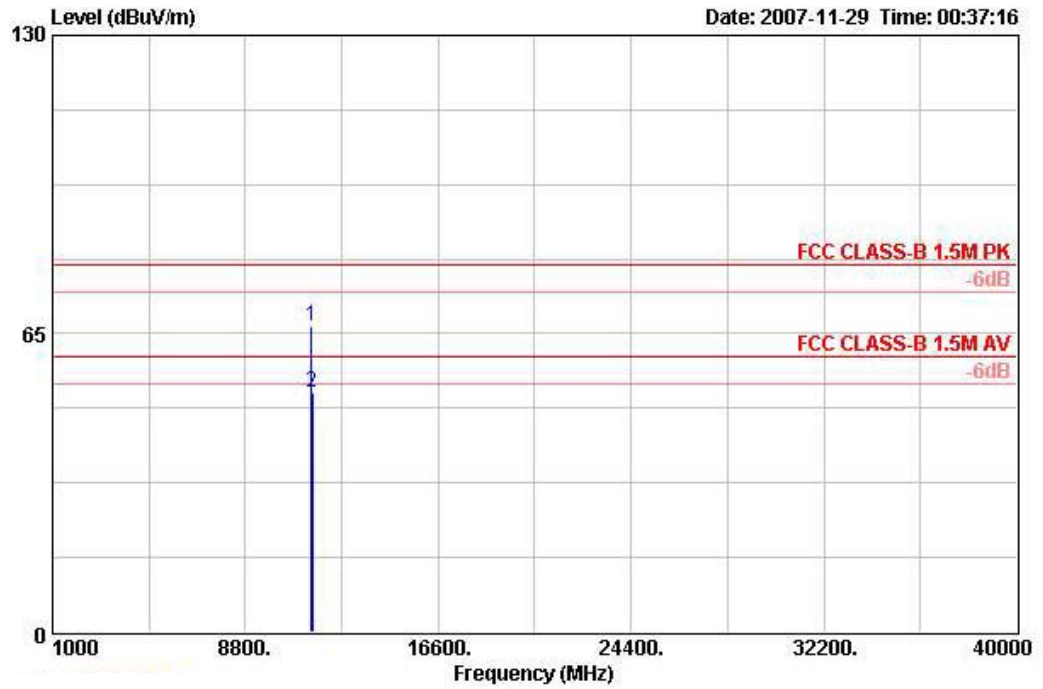

	Freq	Level	Over	Limit	Line Remark	Pol/Phase	Distance	ReadAntenna		Cable Preamp	
			Limit	Line				Level	Factor	Loss	Factor
	MHz	dBuV/m	dB	dBuV/m			m	dBuV	dB/m	dB	dB
1	11486.280	66.74	-13.26	80.00	PEAK	VERTICAL	3	53.16	38.78	9.78	34.98
2	11491.440	52.21	-7.79	60.00	AVERAGE	VERTICAL	3	38.64	38.78	9.78	34.98

Temperature	23°C	Humidity	54%
Test Engineer	Barry Chen	Configurations	1a Draft n MCS8 20MHz CH 157 Ant. 3 + Ant. 5

Horizontal

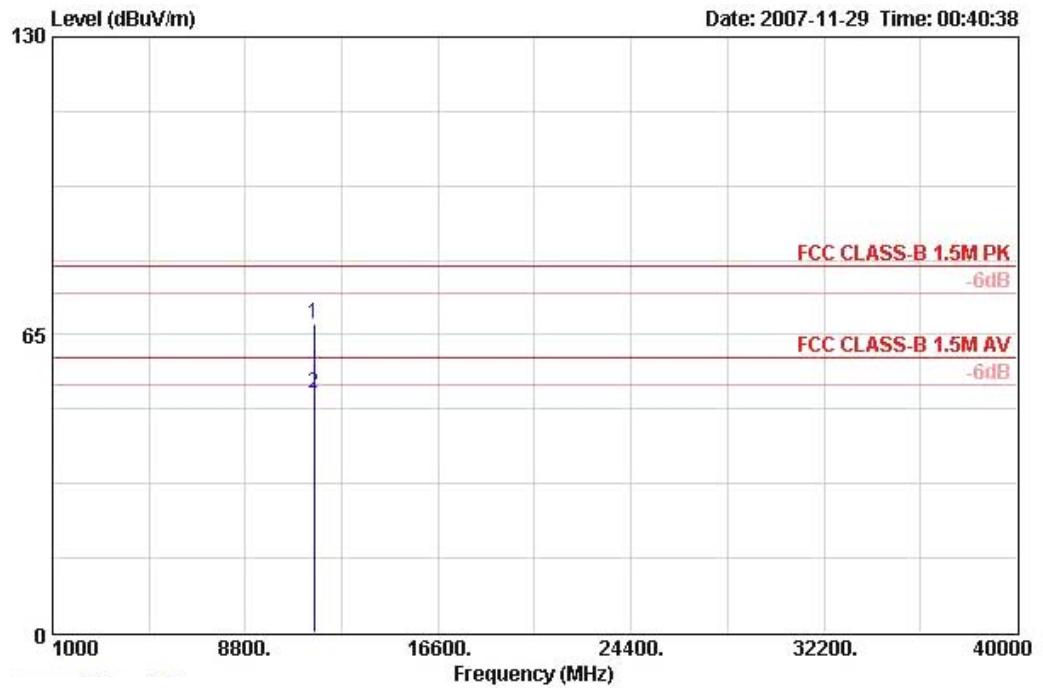

	Freq	Level	Over Limit	Limit Line	Remark	Pol/Phase	Distance	Read Level	Antenna Factor	Cable Loss	Preamp Factor
	MHz	dBuV/m	dB	dBuV/m			m	dBuV	dB/m	dB	dB
1	11563.880	67.23	-12.77	80.00	PEAK	HORIZONTAL	3	53.62	38.82	9.79	35.00
2	11568.720	52.34	-7.66	60.00	AVERAGE	HORIZONTAL	3	38.72	38.83	9.79	35.00

Vertical

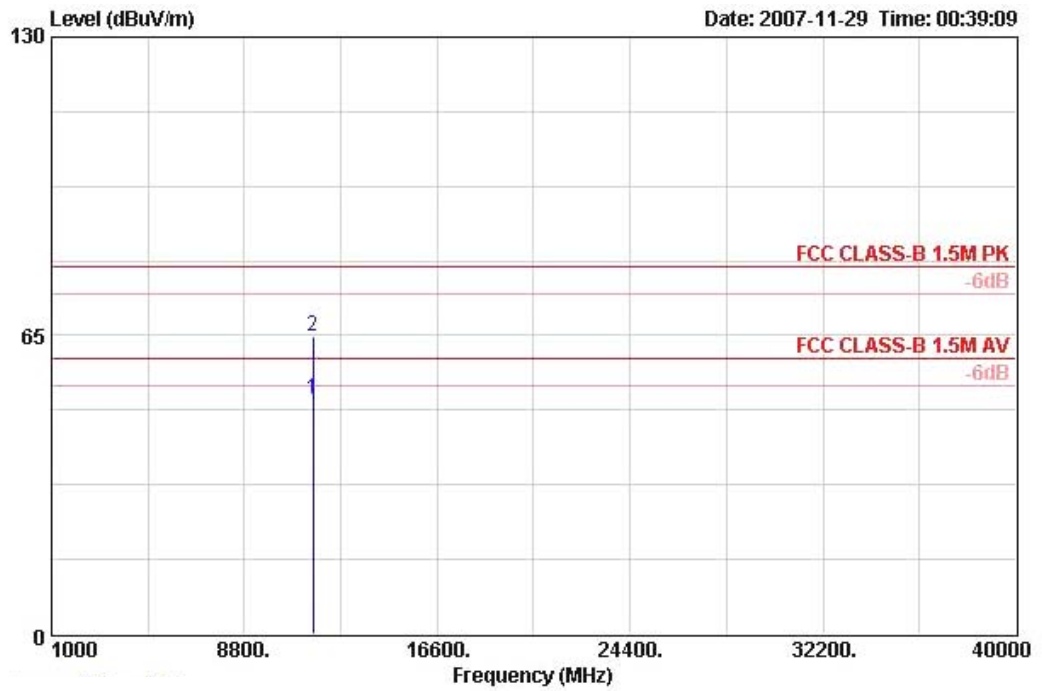

	Freq	Level	Over Limit	Limit	Line Remark	Pol/Phase	Distance	Read Level	Antenna Factor	Cable Loss	Preamp Factor
	MHz	dBuV/m	dB	dBuV/m			m	dBuV	dB/m	dB	dB
1	11568.840	51.03	-8.97	60.00	AVERAGE	VERTICAL	3	37.41	38.83	9.79	35.00
2	11569.160	64.79	-15.21	80.00	PEAK	VERTICAL	3	51.16	38.83	9.79	35.00

Temperature	23°C	Humidity	54%
Test Engineer	Barry Chen	Configurations	11a Draft n MCS8 20MHz CH 165 Ant. 3 + Ant. 5

Horizontal

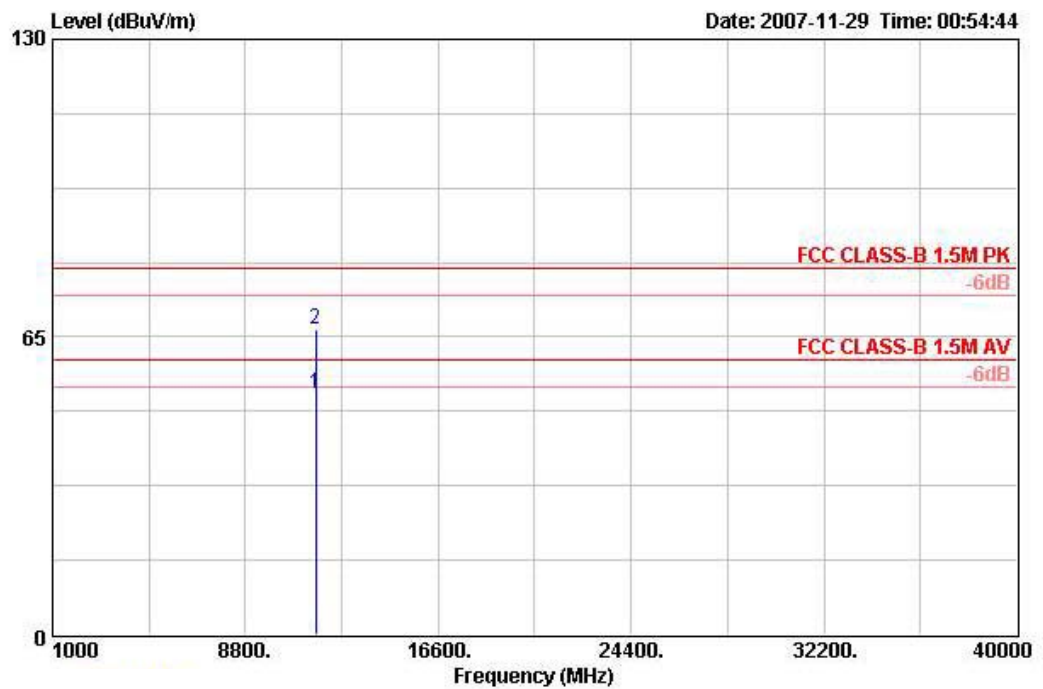

	Freq	Level	Over Limit	Limit Line	Remark	Pol/Phase	Distance	ReadAntenna Level	Antenna Factor	Cable Loss	Preamp Factor
	MHz	dBuV/m	dB	dBuV/m			m	dBuV	dB/m	dB	dB
1	11651.120	52.74	-7.26	60.00	AVERAGE	HORIZONTAL	3	39.07	38.86	9.82	35.01
2	11658.720	66.61	-13.39	80.00	PEAK	HORIZONTAL	3	52.94	38.86	9.82	35.01

Vertical

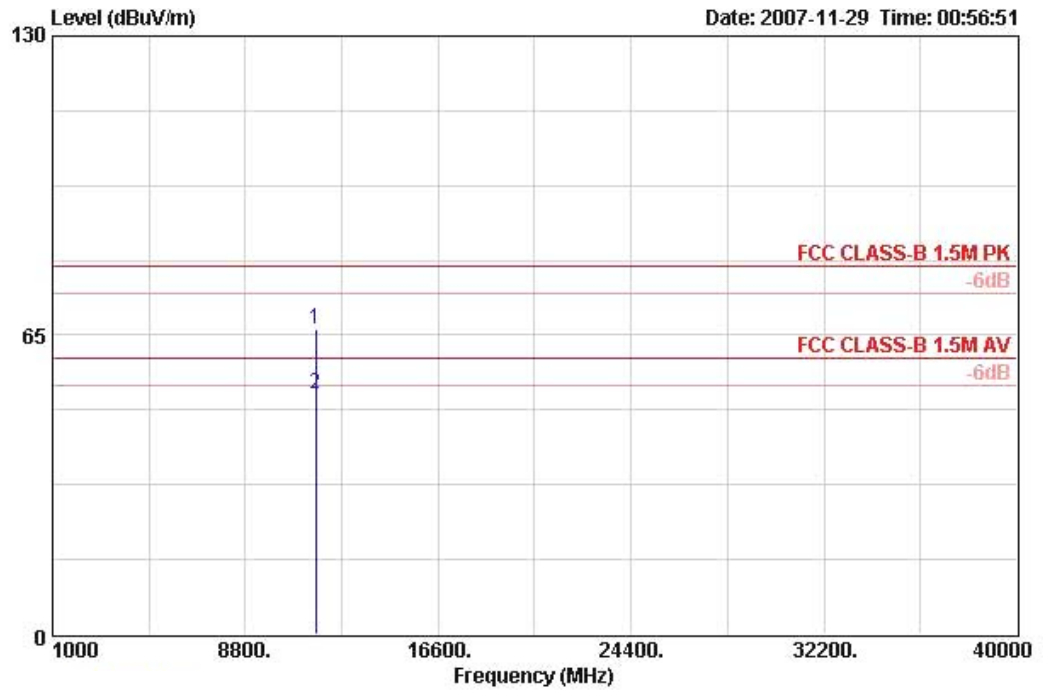

	Freq	Level	Over Limit	Limit	Line	Remark	Pol/Phase	Distance	ReadAntenna	Cable	Preamp
	MHz	dBUV/m	dB	dBUV/m				m	Level	Factor	Loss
									dB	dB/m	dB
1	11646.480	66.40	-13.60	80.00	PEAK	VERTICAL		3	52.74	38.86	9.82
2	11648.760	52.10	-7.90	60.00	AVERAGE	VERTICAL		3	38.43	38.86	9.82

Temperature	23°C	Humidity	54%
Test Engineer	Barry Chen	Configurations	11a Draft n MCS8 40MHz CH 151 Ant. 3 + Ant. 5

Horizontal

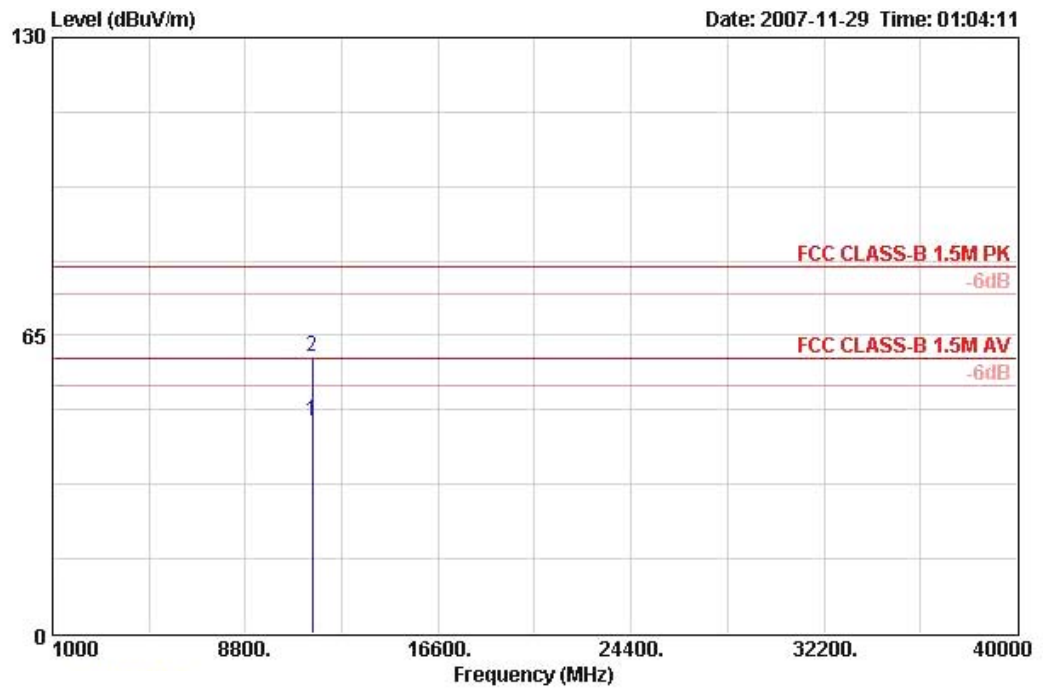

	Freq	Level	Over Limit	Limit Line	Remark	Pol/Phase	Distance	Read Level	Antenna Factor	Cable Loss	Preamp Factor
	MHz	dBuV/m	dB	dBuV/m			m	dBuV	dB/m	dB	dB
1	11503.880	46.26	-13.74	60.00	AVERAGE	HORIZONTAL	3	32.67	38.80	9.78	35.00
2	11508.880	60.28	-19.72	80.00	PEAK	HORIZONTAL	3	46.69	38.80	9.78	35.00

Vertical

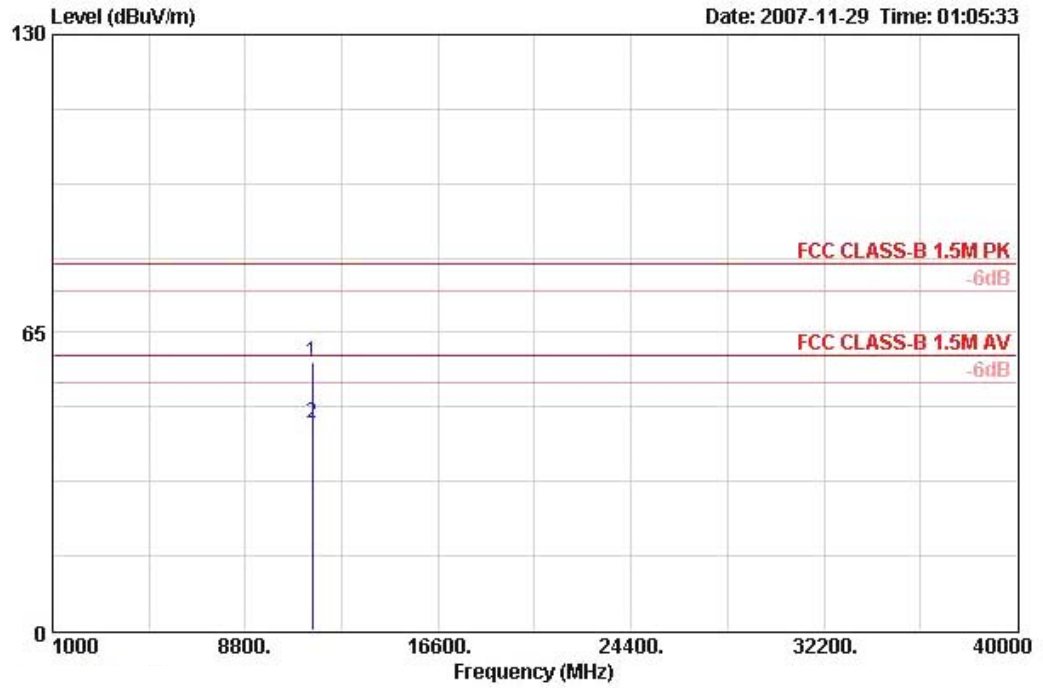

	Freq	Level	Over	Limit	Remark	Pol/Phase	Distance	ReadAntenna		Cable Preamp	
			Limit	Line				Level	Factor	Loss	Factor
	MHz	dBuV/m	dB	dBuV/m			m	dBuV	dB/m	dB	dB
1	11507.720	58.69	-21.31	80.00	PERK	VERTICAL	3	45.10	38.80	9.78	35.00
2	11510.680	45.25	-14.75	60.00	AVERAGE	VERTICAL	3	31.66	38.80	9.78	35.00

Temperature	23°C	Humidity	54%
Test Engineer	Barry Chen	Configurations	11a Draft n MCS8 40MHz CH 159 Ant. 3 + Ant. 5

Horizontal

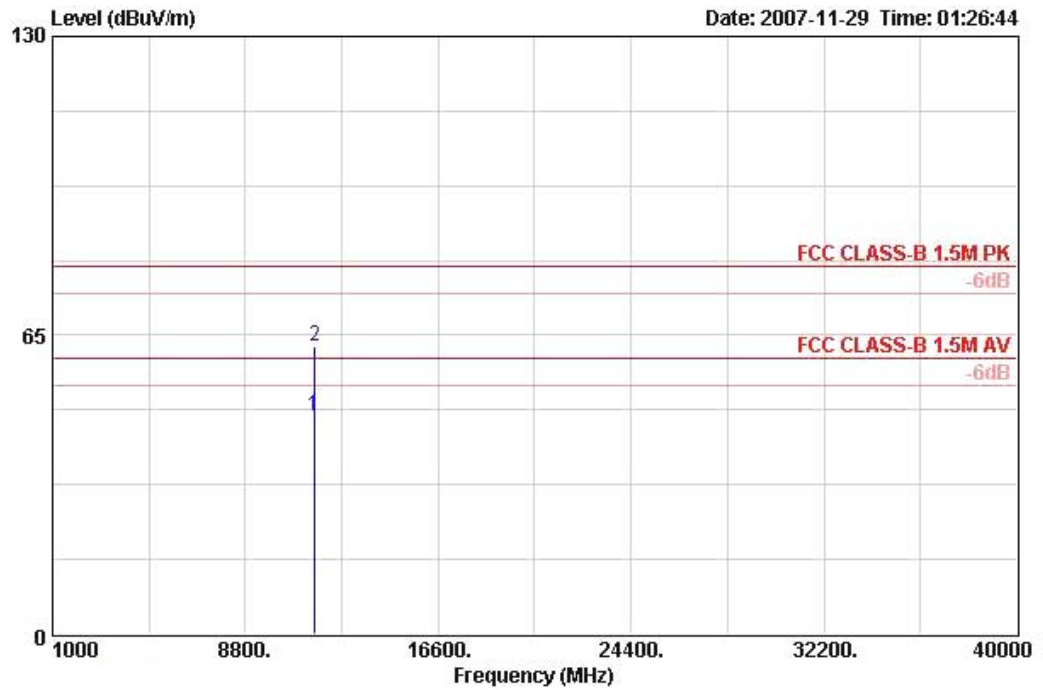

	Freq	Level	Over Limit	Limit	Line Remark	Pol/Phase	Distance	Read Level	Antenna Factor	Cable Loss	Preamp Factor
	MHz	dBuV/m	dB	dBuV/m			m	dBuV	dB/m	dB	dB
1	11591.400	47.26	-12.74	60.00	AVERAGE	HORIZONTAL	3	33.62	38.83	9.80	35.00
2	11594.400	62.54	-17.46	80.00	PEAK	HORIZONTAL	3	48.91	38.83	9.80	35.00

Vertical

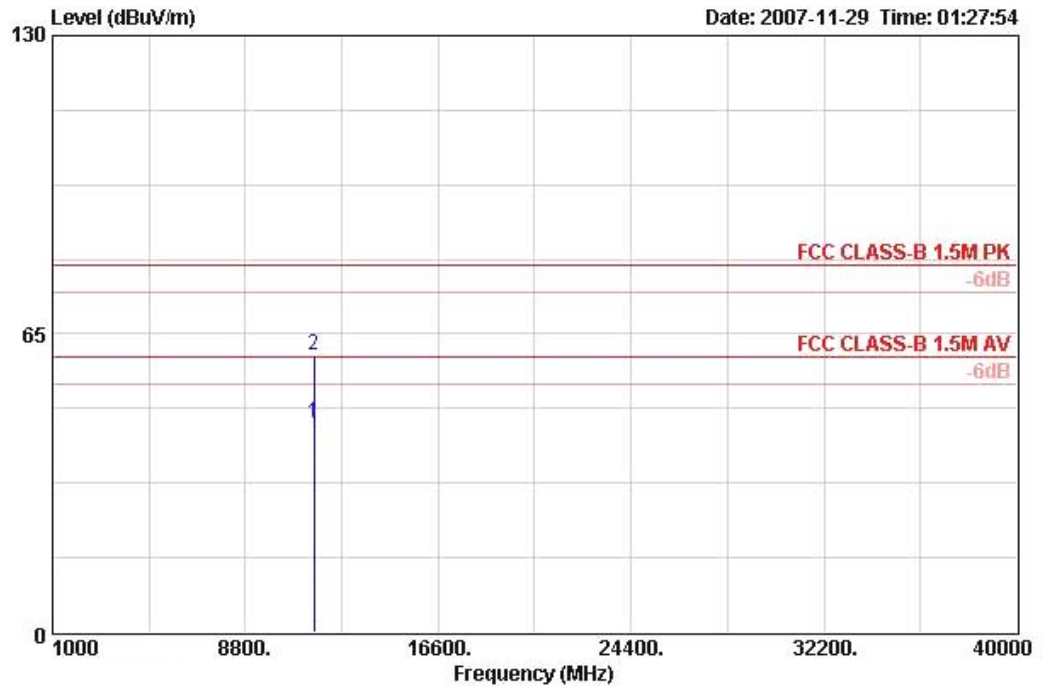

	Freq	Level	Over Limit	Limit Line	Remark	Pol/Phase	Distance	ReadAntenna Level	Antenna Factor	Cable Loss	Preamp Factor
	MHz	dBuV/m	dB	dBuV/m			m	dBuV	dB/m	dB	dB
1	11591.200	45.55	-14.45	60.00	AVERAGE	VERTICAL	3	31.92	38.83	9.80	35.00
2	11591.240	60.42	-19.58	80.00	PEAK	VERTICAL	3	46.79	38.83	9.80	35.00

Note:

The amplitude of spurious emissions that are attenuated by more than 20dB below the permissible value has no need to be reported.

Emission level (dBuV/m) = 20 log Emission level (uV/m).

Corrected Reading: Antenna Factor + Cable Loss + Read Level - Preamp Factor = Level.

4.6. Band Edge Emissions Measurement

4.6.1. Limit

20dBc in any 100 kHz bandwidth outside the operating frequency band. In case the emission fall within the restricted band specified on 15.205(a), then the 15.209(a) limit in the table below has to be followed.

Frequencies (MHz)	Field Strength (micovolts/meter)	Measurement Distance (meters)
0.009~0.490	2400/F(KHz)	300
0.490~1.705	24000/F(KHz)	30
1.705~30.0	30	30
30~88	100	3
88~216	150	3
216~960	200	3
Above 960	500	3

4.6.2. Measuring Instruments and Setting

Please refer to section 5 of equipments list in this report. The following table is the setting of the spectrum analyzer.

Spectrum Parameter	Setting
Attenuation	Auto
Span Frequency	100 MHz
RB / VB (Emission in restricted band)	1 MHz / 1MHz for Peak, 1 MHz / 10Hz for Average
RB / VB (Emission in non-restricted band)	100 KHz /100 KHz for Peak

4.6.3. Test Procedures

1. The test procedure is the same as section 4.5.3, only the frequency range investigated is limited to 100MHz around bandedges.
2. In case the emission is fail due to the used RB/VB is too wide, marker-delta method of FCC Public Notice DA00-705 will be followed.

4.6.4. Test Setup Layout

This test setup layout is the same as that shown in section 4.5.4.

4.6.5. Test Deviation

There is no deviation with the original standard.

4.6.6. EUT Operation during Test

The EUT was programmed to be in continuously transmitting mode.

4.6.7. Test Result of Band Edge and Fundamental Emissions

Temperature	23°C	Humidity	54%
Test Engineer	Barry Chen	Configurations	Draft n MCS8 20MHz Ch 1, 6, 11 Ant. 3 + Ant. 5

Channel 1

	Freq	Level	Over	Limit	Remark	Pol/Phase	Distance	ReadAntenna		Cable		Preamp
			Limit	Line				Level	Factor	Loss	Factor	
	MHz	dBuV/m	dB	dBuV/m			m	dBuV	dB/m	dB	dB	
1 !	2389.800	69.33	-4.67	74.00	PEAK	HORIZONTAL	3	37.00	28.17	4.15	0.00	
2 !	2390.000	52.03	-1.97	54.00	AVERAGE	HORIZONTAL	3	19.70	28.17	4.15	0.00	
3	2409.200	111.31			PEAK	HORIZONTAL	3	78.95	28.21	4.15	0.00	
4	2409.600	101.14			AVERAGE	HORIZONTAL	3	68.78	28.21	4.15	0.00	

Item 3, 4 are the fundamental frequency at 2412 MHz

Channel 6

	Freq	Level	Over	Limit	Remark	Pol/Phase	Distance	ReadAntenna		Cable		Preamp
			Limit	Line				Level	Factor	Loss	Factor	
	MHz	dBuV/m	dB	dBuV/m			m	dBuV	dB/m	dB	dB	
1 !	2390.000	70.10	-3.90	74.00	PEAK	VERTICAL	3	37.77	28.17	4.15	0.00	
2 @	2390.000	53.50	-0.50	54.00	AVERAGE	VERTICAL	3	21.17	28.17	4.15	0.00	
3 @	2435.600	117.03			PEAK	VERTICAL	3	84.60	28.25	4.18	0.00	
4 @	2438.200	104.47			AVERAGE	VERTICAL	3	72.01	28.29	4.18	0.00	

Item 3, 4 are the fundamental frequency at 2437MHz.

Channel 11

	Freq	Level	Over	Limit	Remark	Pol/Phase	Distance	ReadAntenna		Cable		Preamp
			Limit	Line				Level	Factor	Loss	Factor	
	MHz	dBuV/m	dB	dBuV/m			m	dBuV	dB/m	dB	dB	
1 @	2457.600	99.64			AVERAGE	VERTICAL	3	67.11	28.32	4.20	0.00	
2	2464.600	111.54			PEAK	VERTICAL	3	79.01	28.32	4.20	0.00	
3 !	2483.520	53.61	-0.39	54.00	AVERAGE	VERTICAL	3	21.02	28.36	4.23	0.00	
4 !	2483.520	70.33	-3.67	74.00	PEAK	VERTICAL	3	37.74	28.36	4.23	0.00	

Item 1, 2 are the fundamental frequency at 2462 MHz.

Temperature	23°C	Humidity	54%
Test Engineer	Barry Chen	Configurations	Draft n MCS8 40MHz Ch 3, 6, 9 Ant. 3 + Ant. 5

Channel 3

	Freq	Level	Over	Limit	Remark	Pol/Phase	Distance	ReadAntenna		Cable Preamp	
			Limit	Line				Level	Factor	Loss	Factor
	MHz	dBuV/m	dB	dBuV/m			m	dBuV	dB/m	dB	dB
1 !	2389.200	68.45	-5.55	74.00	PEAK	HORIZONTAL	3	36.14	28.17	4.13	0.00
2 @	2389.200	53.24	-0.76	54.00	AVERAGE	HORIZONTAL	3	20.94	28.17	4.13	0.00
3 @	2419.200	92.93			AVERAGE	HORIZONTAL	3	60.54	28.21	4.18	0.00
4 @	2419.200	106.22			PEAK	HORIZONTAL	3	73.83	28.21	4.18	0.00

Item 3, 4 are the fundamental frequency at 2422 MHz.

Channel 6

	Freq	Level	Over	Limit	Remark	Pol/Phase	Distance	ReadAntenna		Cable Preamp	
			Limit	Line				Level	Factor	Loss	Factor
	MHz	dBuV/m	dB	dBuV/m			m	dBuV	dB/m	dB	dB
1 @	2390.000	53.46	-0.54	54.00	AVERAGE	HORIZONTAL	3	21.14	28.17	4.15	0.00
2	2390.000	66.16	-7.84	74.00	PEAK	HORIZONTAL	3	33.83	28.17	4.15	0.00
3 @	2441.000	98.16			AVERAGE	HORIZONTAL	3	65.67	28.29	4.20	0.00
4 @	2441.800	111.89			PEAK	HORIZONTAL	3	79.41	28.29	4.20	0.00

Item 3, 4 are the fundamental frequency at 2437MHz.

Channel 9

	Freq	Level	Over	Limit	ReadAntenna		Cable Preamp		Remark	Ant	Table	Pol/Phase
			Limit	Line	Level	Factor	Loss	Factor		Pos	Pos	
	MHz	dBuV/m	dB	dBuV/m	dBuV	dB/m	dB	dB		cm	deg	
1 @	2456.800	95.20			62.68	28.32	4.20	0.00	AVERAGE	111	81	VERTICAL
2	2460.800	111.42			78.89	28.32	4.20	0.00	PEAK	111	81	VERTICAL
3 !	2484.460	53.83	-0.17	54.00	21.24	28.36	4.23	0.00	AVERAGE	111	81	VERTICAL
4 !	2484.460	70.77	-3.23	74.00	38.18	28.36	4.23	0.00	PEAK	111	81	VERTICAL

Item 1, 2 are the fundamental frequency at 2452 MHz.

Note:

Emission level (dBuV/m) = 20 log Emission level (uV/m).

Corrected Reading: Antenna Factor + Cable Loss + Read Level - Preamp Factor = Level.

Temperature	23°C	Humidity	54%
Test Engineer	Barry Chen	Configurations	11a Draft n MCS8 20MHz CH 149, 157, 165 Ant. 3+Ant. 5

Channel 149

	Freq	Level	Over	Limit	Remark	Pol/Phase	Distance	ReadAntenna		Cable Preamp	
			Limit	Line				Level	Factor	Loss	Factor
	MHz	dBuV/m	dB	dBuV/m			m	dBuV	dB/m	dB	dB
1 ☺	5740.000	106.64			AVERAGE	VERTICAL	3	65.46	34.35	6.84	0.00
2 ☺	5748.000	118.10			PEAK	VERTICAL	3	76.91	34.35	6.84	0.00

Item 1, 2 are the fundamental frequency at 5745 MHz.

Channel 157

	Freq	Level	Over	Limit	Remark	Pol/Phase	Distance	ReadAntenna		Cable Preamp	
			Limit	Line				Level	Factor	Loss	Factor
	MHz	dBuV/m	dB	dBuV/m			m	dBuV	dB/m	dB	dB
1 ☺	5790.200	105.97			AVERAGE	VERTICAL	3	64.75	34.36	6.86	0.00
2	5790.400	117.52			PEAK	VERTICAL	3	76.30	34.36	6.86	0.00

Item 1, 2 are the fundamental frequency at 5785 MHz.

Channel 165

	Freq	Level	Over	Limit	Remark	Pol/Phase	Distance	ReadAntenna		Cable Preamp	
			Limit	Line				Level	Factor	Loss	Factor
	MHz	dBuV/m	dB	dBuV/m			m	dBuV	dB/m	dB	dB
1	5820.000	105.31			AVERAGE	VERTICAL	3	64.07	34.37	6.88	0.00
2 ☺	5820.600	116.34			PEAK	VERTICAL	3	75.10	34.37	6.88	0.00

Item 1, 2 are the fundamental frequency at 5825 MHz.

Note:

Emission level (dBuV/m) = 20 log Emission level (uV/m).

Corrected Reading: Antenna Factor + Cable Loss + Read Level - Preamp Factor = Level.

Temperature	23°C	Humidity	54%
Test Engineer	Barry Chen	Configurations	11a Draft n MCS8 40MHz CH 151, 159 Ant. 3+Ant. 5

Channel 151

	Freq	Level	Over	Limit	Line Remark	Pol/Phase	Distance	ReadAntenna		Cable Preamp	
			Limit	Line				Level	Factor	Loss	Factor
	MHz	dBuV/m	dB	dBuV/m			m	dBuV	dB/m	dB	dB
1 ☺	5757.800	113.45			PEAK	VERTICAL	3	72.25	34.35	6.85	0.00
2 ☺	5759.800	100.54			AVERAGE	VERTICAL	3	59.34	34.35	6.85	0.00

Item 1, 2 are the fundamental frequency at 5755 MHz.

Channel 159

	Freq	Level	Over	Limit	Line Remark	Pol/Phase	Distance	ReadAntenna		Cable Preamp	
			Limit	Line				Level	Factor	Loss	Factor
	MHz	dBuV/m	dB	dBuV/m			m	dBuV	dB/m	dB	dB
1	5800.200	99.65			AVERAGE	VERTICAL	3	58.43	34.36	6.86	0.00
2 ☺	5800.200	113.00			PEAK	VERTICAL	3	71.77	34.36	6.86	0.00

Item 1, 2 are the fundamental frequency at 5795 MHz.

Note:

Emission level (dBuV/m) = 20 log Emission level (uV/m).

Corrected Reading: Antenna Factor + Cable Loss + Read Level - Preamp Factor = Level.

For Emission not in Restricted Band

Low Band Edge Plot on Configuration Draft n MCS8 20MHz Ant. 3 + Ant. 5 / 2412 MHz

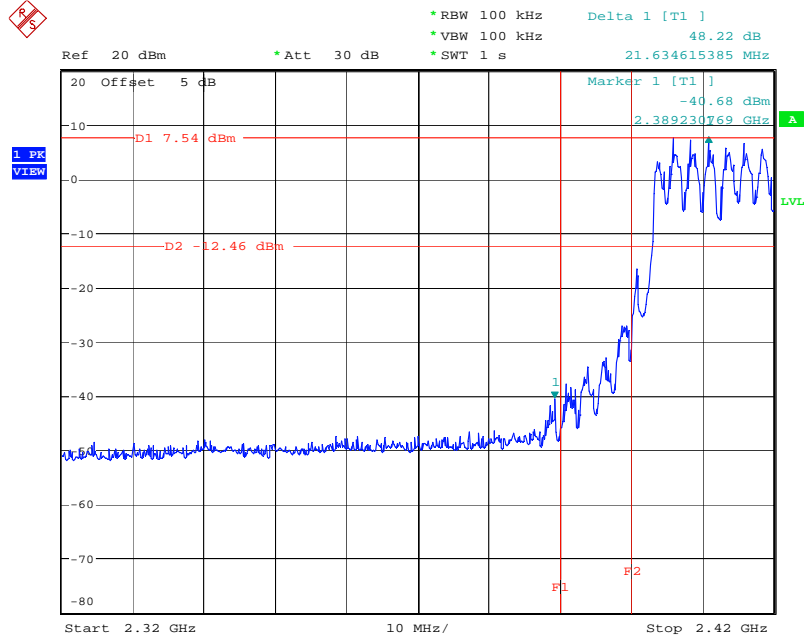

Date: 11.DEC.2007 09:52:34

High Band Edge Plot on Configuration Draft n MCS8 20MHz Ant. 3 + Ant. 5 / 2462 MHz

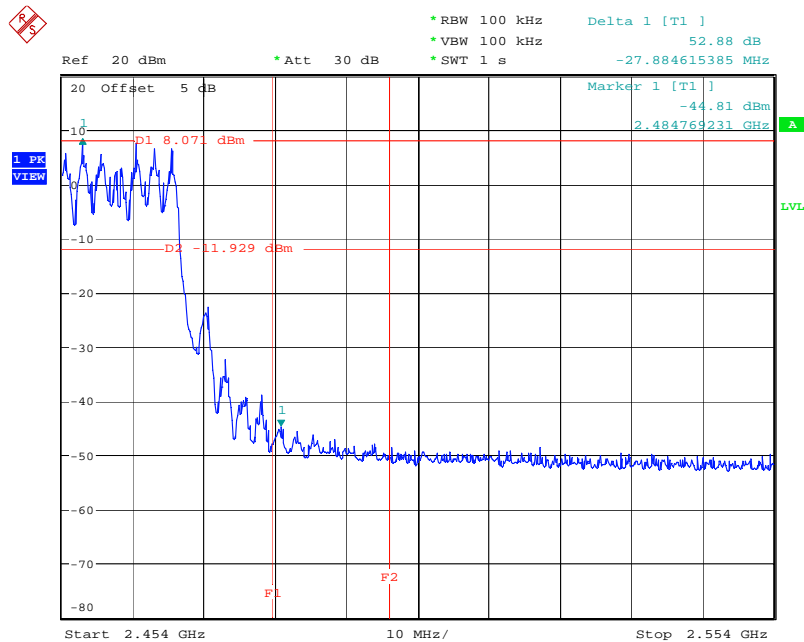

Date: 1.DEC.2007 09:33:52

Low Band Edge Plot on Configuration Draft n MCS8 40MHz Ant. 3 + Ant. 5 / 2422 MHz

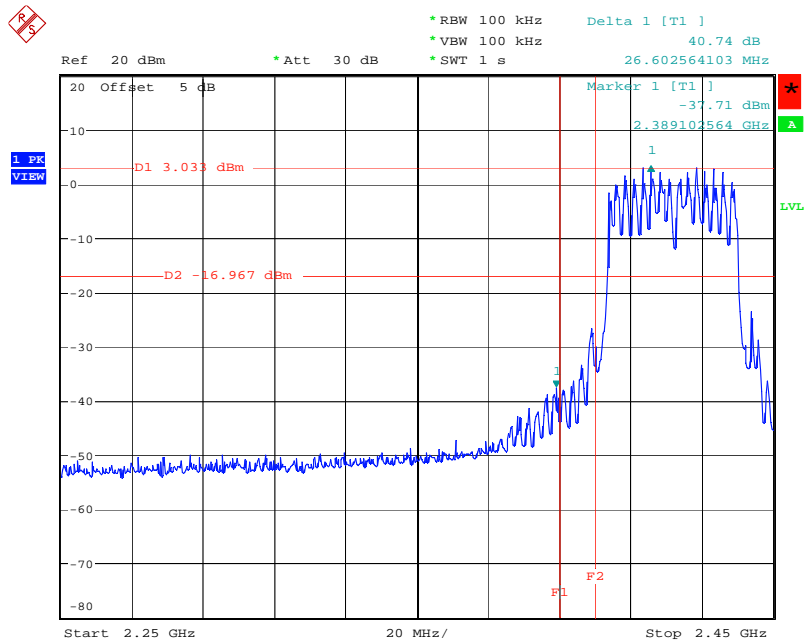

Date: 11.DEC.2007 10:53:40

High Band Edge Plot on Configuration Draft n MCS8 40MHz Ant. 3 + Ant. 5 / 2452 MHz

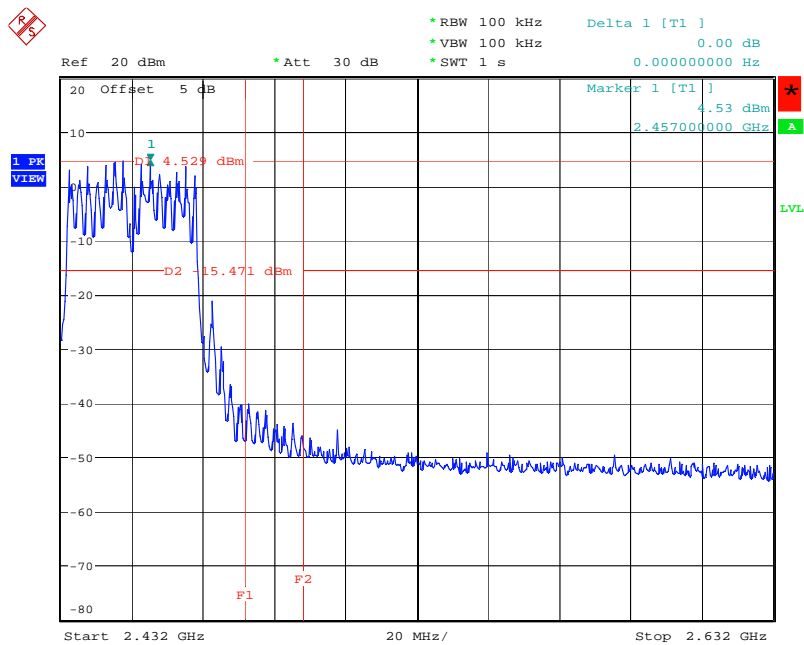

Date: 11.DEC.2007 10:59:04

Low Band Edge Plot on Configuration 11a Draft n MCS8 20MHz Ant. 3+Ant. 5 / 5745 MHz

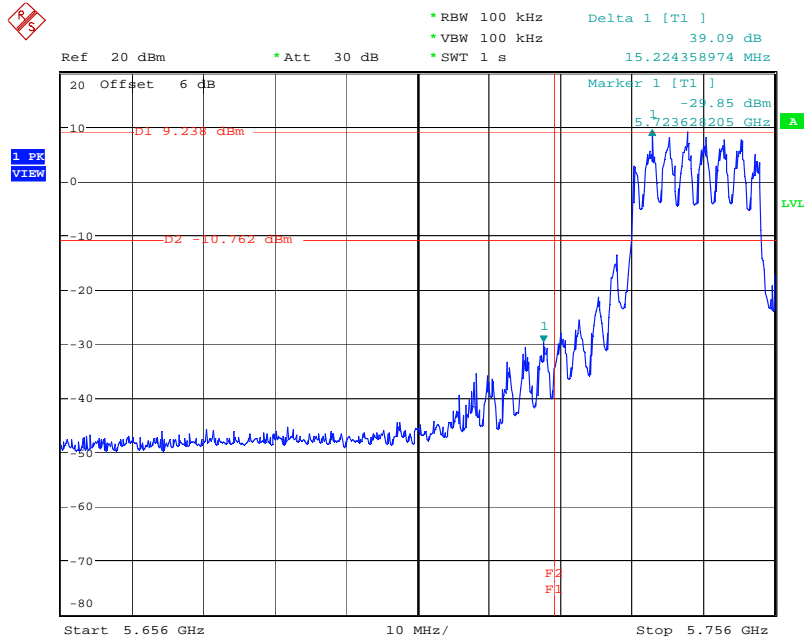

Date: 1.DEC.2007 09:53:07

High Band Edge Plot on Configuration 11a Draft n MCS8 20MHz Ant. 3+Ant. 5 / 5825 MHz

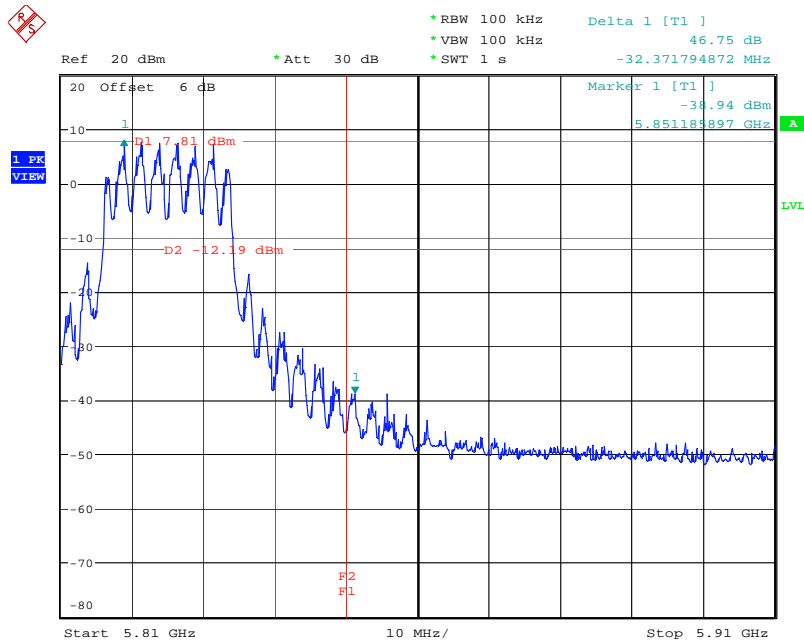

Date: 1.DEC.2007 09:56:03

Low Band Edge Plot on Configuration 11a Draft n MCS8 40MHz Ant. 3+Ant. 5 / 5755 MHz

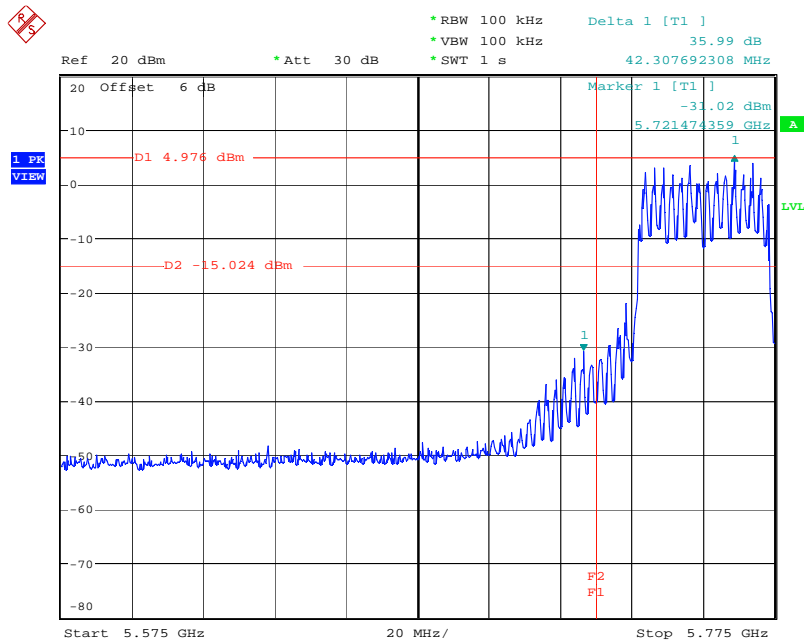

Date: 3.DEC.2007 12:32:21

High Band Edge Plot on Configuration 11a Draft n MCS8 40MHz Ant. 3+Ant. 5 / 5795 MHz

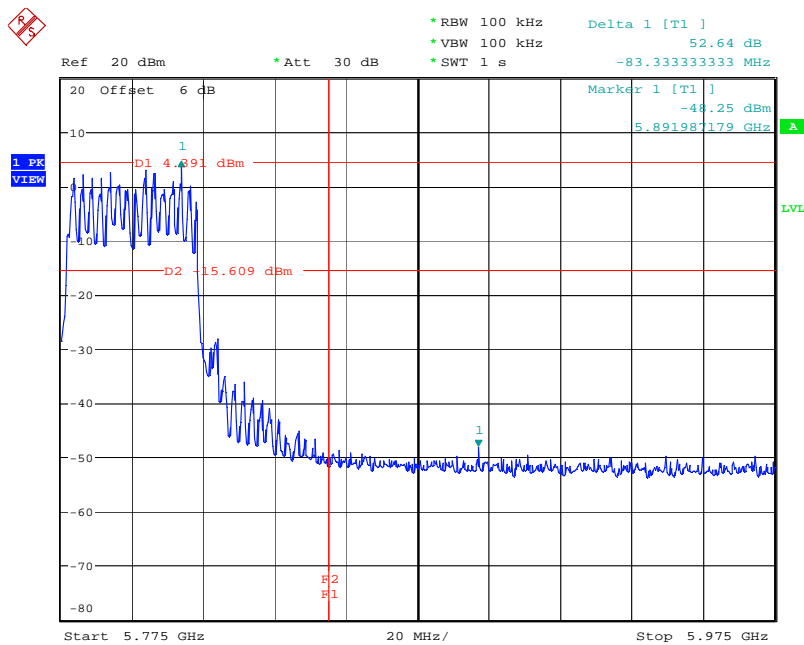

Date: 3.DEC.2007 12:33:59

4.7. Antenna Requirements

4.7.1. Limit

Except for special regulations, the Low-power Radio-frequency Devices must not be equipped with any jacket for installing an antenna with extension cable. An intentional radiator shall be designed to ensure that no antenna other than that furnished by the responsible party shall be used with the device. The use of a permanently attached antenna or of an antenna that uses a unique coupling to the intentional radiator shall be considered sufficient to comply with the provisions of this Section. The manufacturer may design the unit so that the user can replace a broken antenna, but the use of a standard antenna jack or electrical connector is prohibited. Further, this requirement does not apply to intentional radiators that must be professionally installed.

4.7.2. Antenna Connector Construction

Please refer to section 3.3 in this test report; antenna connector complied with the requirements.

5. LIST OF MEASURING EQUIPMENTS

Instrument	Manufacturer	Model No.	Serial No.	Characteristics	Calibration Date	Remark
EMC Receiver	R&S	ESCS 30	100359	9kHz – 2.75GHz	Mar. 01, 2007	Conduction (CO04-HY)
LISN	MessTec	NNB-2/16Z	99079	9kHz – 30MHz	Mar. 31, 2007	Conduction (CO04-HY)
LISN (Support Unit)	EMCO	3810/2NM	9703-1839	9kHz – 30MHz	Mar. 22, 2007	Conduction (CO04-HY)
RF Cable-CON	UTIFLEX	3102-26886-4	CB049	9kHz – 30MHz	Apr. 20, 2007	Conduction (CO04-HY)
ISN	SCHAFFNER	ISN T400	21653	9kHz –30MHz	May 09, 2007	Conduction (CO04-HY)
EMI Filter	LINDGREN	LRE-2030	2651	< 450 Hz	N/A	Conduction (CO04-HY)
Isolation Transformer	Erika Fiedler OHG	D-65396 Walluf	58	45MHz-2.15GHz	N/A	Conduction (CO04-HY)
3m Semi Anechoic Chamber	SIDT FRANKONIA	SAC-3M	03CH03-HY	30 MHz - 1 GHz 3m	Jun. 14, 2007	Radiation (03CH03-HY)
Amplifier	SCHAFFNER	CPA9231A	1886	9 kHz - 2 GHz	Jan. 22, 2007	Radiation (03CH03-HY)
Amplifier	Agilent	8449B	3008A02120	1 GHz - 26.5 GHz	Jun. 07, 2007	Radiation (03CH03-HY)
Amplifier	MITEQ	AMF-6F-260400	923364	26.5 GHz - 40 GHz	Jan. 22, 2007*	Radiation (03CH03-HY)
Spectrum Analyzer	R&S	FSP40	100305	9 kHz - 40 GHz	Sep. 27, 2007	Radiation (03CH03-HY)
Loop Antenna	R&S	HFH2-Z2	860004/001	9 kHz - 30 MHz	May 23, 2006*	Radiation (03CH03-HY)
Bilog Antenna	SCHAFFNER	CBL 6112D	22237	30 MHz – 1 GHz	Jul. 21, 2007	Radiation (03CH03-HY)
Horn Antenna	EMCO	3115	6741	1GHz ~ 18GHz	May 04, 2007	Radiation (03CH03-HY)
Horn Antenna	SCHWARZBECK	BBHA9170	BBHA9170154	15 GHz - 40 GHz	NCR	Radiation (03CH03-HY)
RF Cable-R03m	Jye Bao	RG142	CB021	30 MHz - 1 GHz	Dec. 03, 2007	Radiation (03CH03-HY)
RF Cable-HIGH	SUHNER	SUCOFLEX 106	03CH03-HY	1 GHz - 40 GHz	Dec. 03, 2007	Radiation (03CH03-HY)
Turn Table	HD	DS 420	420/650/00	0 – 360 degree	N/A	Radiation (03CH03-HY)
Antenna Mast	HD	MA 240	240/560/00	1 m - 4 m	N/A	Radiation (03CH03-HY)
Spectrum Analyzer	R&S	FSP30	100023	9kHz ~ 30GHz	Dec. 17, 2007	Conducted (TH01-HY)
Power Meter	R&S	NRVS	100444	DC ~ 40GHz	Jun. 27, 2007	Conducted (TH01-HY)
Power Sensor	R&S	NRV-Z51	100458	DC ~ 30GHz	Jun. 27, 2007	Conducted (TH01-HY)
Power Sensor	R&S	NRV-Z32	100057	30MHz ~ 6GHz	Jun. 27, 2007	Conducted (TH01-HY)
AC Power Source	HPC	HPA-500W	HPA-9100024	AC 0 ~ 300V	May 04, 2007*	Conducted (TH01-HY)
DC Power Source	G.W.	GPC-6030D	C671845	DC 1V ~ 60V	Mar. 03, 2007	Conducted (TH01-HY)

Instrument	Manufacturer	Model No.	Serial No.	Characteristics	Calibration Date	Remark
Temp. and Humidity Chamber	KSON	THS-C3L	612	N/A	Oct. 01, 2007	Conducted (TH01-HY)
RF CABLE-1m	Jye Bao	RG142	CB034-1m	20MHz ~ 7GHz	Dec. 01, 2007	Conducted (TH01-HY)
RF CABLE-2m	Jye Bao	RG142	CB035-2m	20MHz ~ 1GHz	Dec. 01, 2007	Conducted (TH01-HY)
Signal Generator	R&S	SMR40	100116	10MHz ~ 40GHz	Mar. 07, 2007	Conducted (TH01-HY)

Note: Calibration Interval of instruments listed above is one year.

* Calibration Interval of instruments listed above is two year.

NCR means Non-Calibration required.

6. TEST LOCATION

SHIJR	ADD : 6Fl., No. 106, Sec. 1, Shintai 5th Rd., Shijr City, Taipei, Taiwan 221, R.O.C. TEL : 886-2-2696-2468 FAX : 886-2-2696-2255
HWA YA	ADD : No. 52, Hwa Ya 1st Rd., Kwei-Shan Hsiang, Tao Yuan Hsien, Taiwan, R.O.C. TEL : 886-3-327-3456 FAX : 886-3-318-0055
LINKOU	ADD : No. 30-2, Dingfu Tsuen, Linkou Shiang, Taipei, Taiwan 244, R.O.C TEL : 886-2-2601-1640 FAX : 886-2-2601-1695
DUNGHU	ADD : No. 3, Lane 238, Kangle St., Neihu Chiu, Taipei, Taiwan 114, R.O.C. TEL : 886-2-2631-4739 FAX : 886-2-2631-9740
JUNGHE	ADD : 7Fl., No. 758, Jungjeng Rd., Junghe City, Taipei, Taiwan 235, R.O.C. TEL : 886-2-8227-2020 FAX : 886-2-8227-2626
NEIHU	ADD : 4Fl., No. 339, Hsin Hu 2 nd Rd., Taipei 114, Taiwan, R.O.C. TEL : 886-2-2794-8886 FAX : 886-2-2794-9777
JHUBEI	ADD : No.8, Lane 724, Bo-ai St., Jhubei City, HsinChu County 302, Taiwan, R.O.C. TEL : 886-3-656-9065 FAX : 886-3-656-9085

7. TAF CERTIFICATE OF ACCREDITATION



Certificate No. : L1190-070110

財團法人全國認證基金會
Taiwan Accreditation Foundation

Certificate of Accreditation

This is to certify that

Sporton International Inc.

EMC & Wireless Communications Laboratory

No.52, Hwa Ya 1st Rd., Hwa Ya Technology Park, Kwei-Shan Hsiang, Tao Yuan Hsien,
Taiwan, R.O.C.

is accredited in respect of laboratory

Accreditation Criteria	: ISO/IEC 17025:2005
Accreditation Number	: 1190
Originally Accredited	: December 15, 2003
Effective Period	: January 10, 2007 to January 09, 2010
Accredited Scope	: Testing Field, see described in the Appendix
Specific Accreditation Program	: Accreditation Program for Designated Testing Laboratory for Commodities Inspection Accreditation Program for Telecommunication Equipment Testing Laboratory



Jay-San Chen
President, Taiwan Accreditation Foundation
Date : January 10, 2007

P1, total 9 pages

The Appendix forms an integral part of this Certificate, which shall be invalid when used without the Appendix.