



SPORTON International Inc.

No. 52, Hwa Ya 1st Rd., Kwei-Shan Hsiang, TaoYuan Hsien, Taiwan, R.O.C.
Ph: 886-3-327-3456 / FAX: 886-3-327-0973 / www.sporton.com.tw

FCC RADIO TEST REPORT

Applicant's company	NETGEAR, Inc.
Applicant Address	4500 Great America Parkway, Santa Clara, CA 95054, USA
FCC ID	PY307100061
Manufacturer's company	Ambit Microsystems (Shanghai) Ltd.
Manufacturer Address	No. 1925, Nanle Road, Songjiang Export Processing Zone, Shanghai, China

Product Name	RangeMax™ Next Wireless-N Router
Brand Name	NETGEAR
Model Name	WNR834B v2
Test Rule	47 CFR FCC Part 15 Subpart C § 15.247
Test Freq. Range	2400 ~ 2483.5MHz
Received Date	Apr. 12, 2007
Final Test Date	May 23, 2007
Submission Type	Original Equipment



Statement

Test result included is only for the Draft n part of the product.

The test result in this report refers exclusively to the presented test model / sample.

Without written approval of SPORTON International Inc., the test report shall not be reproduced except in full.

The measurements and test results shown in this test report were made in accordance with the procedures and found in compliance with the limit given in **ANSI C63.4-2003** and **47 CFR FCC Part 15 Subpart C**.

The test equipment used to perform the test is calibrated and traceable to NML/ROC.



Table of Contents

1. CERTIFICATE OF COMPLIANCE	1
2. SUMMARY OF THE TEST RESULT	2
3. GENERAL INFORMATION	3
3.1. Product Details.....	3
3.2. Accessories.....	4
3.3. Table for Filed Antenna.....	5
3.4. Table for Carrier Frequencies	6
3.5. Table for Test Modes.....	6
3.6. Table for Testing Locations.....	7
3.7. Table for Supporting Units	7
3.8. Table for Parameters of Test Software Setting	7
3.9. Test Configurations	8
4. TEST RESULT	10
4.1. AC Power Line Conducted Emissions Measurement.....	10
4.2. Maximum Peak Output Power Measurement	14
4.3. Power Spectral Density Measurement	17
4.4. 6dB Spectrum Bandwidth Measurement	29
4.5. Radiated Emissions Measurement	41
4.6. Band Edge Emissions Measurement	59
4.7. Antenna Requirements	66
5. LIST OF MEASURING EQUIPMENTS	67
6. TEST LOCATION.....	69
7. TAF CERTIFICATE OF ACCREDITATION	70
APPENDIX A. PHOTOGRAPHS OF EUT.....	A1 ~ A14
APPENDIX B. TEST PHOTOS.....	B1 ~ B5
APPENDIX C. MAXIMUM PERMISSIBLE EXPOSURE.....	C1 ~C4



History of This Test Report

Original Issue Date: May 29, 2007

Report No.: FR750820AA

No additional attachment.

Additional attachment were issued as following record:

Attachment No.	Issue Date	Description



1. CERTIFICATE OF COMPLIANCE

Product Name : RangeMax™ Next Wireless-N Router
Brand Name : NETGEAR
Model Name : WNR834B v2
Applicant : NETGEAR, Inc.
Test Rule Part(s) : 47 CFR FCC Part 15 Subpart C § 15.247

Sporton International as requested by the applicant to evaluate the EMC performance of the product sample received on Apr. 12, 2007 would like to declare that the tested sample has been evaluated and found to be in compliance with the tested rule parts. The data recorded as well as the test configuration specified is true and accurate for showing the sample's EMC nature.

A handwritten signature in blue ink that reads 'Wayne Hsu 29.I.07'.

Wayne Hsu

SPORTON INTERNATIONAL INC.

2. SUMMARY OF THE TEST RESULT

Applied Standard: 47 CFR FCC Part 15 Subpart C				
Part	Rule Section	Description of Test	Result	Under Limit
4.1	15.207	AC Power Line Conducted Emissions	Complies	0.31 dB
4.2	15.247(b)(3)	Maximum Peak Conducted Output Power	Complies	5.04 dB
4.3	15.247(e)	Power Spectral Density	Complies	13.30 dB
4.4	15.247(a)(2)	6dB Spectrum Bandwidth	Complies	-
4.5	15.247(d)	Radiated Emissions	Complies	3.12 dB
4.6	15.247(d)	Band Edge Emissions	Complies	0.67 dB
4.7	15.203	Antenna Requirements	Complies	-

Test Items	Uncertainty	Remark
AC Power Line Conducted Emissions	±2.3dB	Confidence levels of 95%
Maximum Peak Conducted Output Power	±0.8dB	Confidence levels of 95%
Power Spectral Density	±0.5dB	Confidence levels of 95%
6dB Spectrum Bandwidth	±8.5×10 ⁻⁸	Confidence levels of 95%
Radiated Emissions (9kHz~30MHz)	±0.8dB	Confidence levels of 95%
Radiated Emissions (30MHz~1000MHz)	±1.9dB	Confidence levels of 95%
Radiated / Band Edge Emissions (1GHz~18GHz)	±1.9dB	Confidence levels of 95%
Radiated Emissions (18GHz~40GHz)	±1.9dB	Confidence levels of 95%
Temperature	±0.7°C	Confidence levels of 95%
Humidity	±3.2%	Confidence levels of 95%
DC / AC Power Source	±1.4%	Confidence levels of 95%

3. GENERAL INFORMATION

3.1. Product Details

Items	Description
Product Type	WLAN (2TX, 3RX)
Radio Type	Intentional Transceiver
Power Type	Power Adapter
Modulation&	see the below table for draft n
Data Modulation	OFDM (BPSK / QPSK / 16QAM / 64QAM)
Data Rate (Mbps)	see the below table for Draft n
Frequency Range	2400 ~ 2483.5MHz
Channel Number	11 for 20MHz bandwidth ; 7 for 40MHz bandwidth
Channel Band Width (99%)	MCS8 (20MHz) : 17.59 MHz MCS8 (40MHz) : 36.08 MHz
Conducted Output Power	MCS8 (20MHz) : 24.96 dBm MCS8 (40MHz) : 21.56 dBm
Carrier Frequencies	Please refer to section 3.4
Antenna	Please refer to section 3.3

Antenna & Band width

Antenna	Single (TX)		Two (TX)	
	20 MHz	40 MHz	20 MHz	40 MHz
Band width Mode				
802.11b	V	X	X	X
802.11g	X	X	V	X
Draft n	X	X	V	V

Draft n spec

MCS Index	Nss	Modulation	R	NBPS	NCBPS		NDBPS		Datarate(Mbps)			
									800nsGI		400nsGI	
					20MHz	40MHz	20MHz	40MHz	20MHz	40MHz	20MHz	40MHz
0	1	BPSK	1/2	1	52	108	26	54	6.5	13.5	7.200	15
1	1	QPSK	1/2	2	104	216	52	108	13.0	27.0	14.400	30
2	1	QPSK	3/4	2	104	216	78	162	19.5	40.5	21.700	45
3	1	16-QAM	1/2	4	208	432	104	216	26.0	54.0	28.900	60
4	1	16-QAM	3/4	4	208	432	156	324	39.0	81.0	43.300	90
5	1	64-QAM	2/3	6	312	648	208	432	52.0	108.0	57.800	120
6	1	64-QAM	3/4	6	312	648	234	486	58.5	121.5	65.000	135
7	1	64-QAM	5/6	6	312	648	260	540	65.0	135.0	72.200	150
8	2	BPSK	1/2	1	104	216	52	108	13.0	27.0	14.444	30
9	2	QPSK	1/2	2	208	432	104	216	26.0	54.0	28.889	60
10	2	QPSK	3/4	2	208	432	156	324	39.0	81.0	43.333	90
11	2	16-QAM	1/2	4	416	864	208	432	52.0	108.0	57.778	120
12	2	16-QAM	3/4	4	416	864	312	648	78.0	162.0	86.667	180
13	2	64-QAM	2/3	6	624	1296	416	864	104.0	216.0	115.556	240
14	2	64-QAM	3/4	6	624	1296	468	972	117.0	243.0	130.000	270
15	2	64-QAM	5/6	6	624	1296	520	1080	130.0	270.0	144.444	300

Symbol	Explanation
NSS	Number of spatial streams
R	Code rate
NBPS	Number of coded bits per single carrier
NCBPS	Number of coded bits per symbol
NDBPS	Number of data bits per symbol
GI	guard interval

3.2. Accessories

Power	Brand	Model	Rating
Adapter	NETGEAR	DSA-12R-12 AUS 120120	Input: 100-120VAC, 50/60Hz, 0.3A Output: +12V, 1A
Others			
Snap-on stand			
Ethernet cable: 1.45m, non-shielded			

3.3. Table for Filed Antenna

Ant.	Brand	Model Name	Antenna Type	Connector	Gain (dBi)	Remark
A	Wha Yu	C147-510271-A	Dipole Antenna	Reversed-SMA	1.8	TX / RX Ant.
B	Wha Yu	C147-510271-A	Dipole Antenna	Reversed-SMA	1.8	TX / RX Ant.
C	Wha Yu	C147-510271-A	Dipole Antenna	Reversed-SMA	1.8	TX / RX Ant.

Note: The EUT has three antennas.

For draft n: Antenna A, antenna B and antenna C can be used as the transmit/receive antenna.

The three antennas couldn't transmit simultaneously but could receive simultaneously.

Only two antennas could transmit simultaneously.

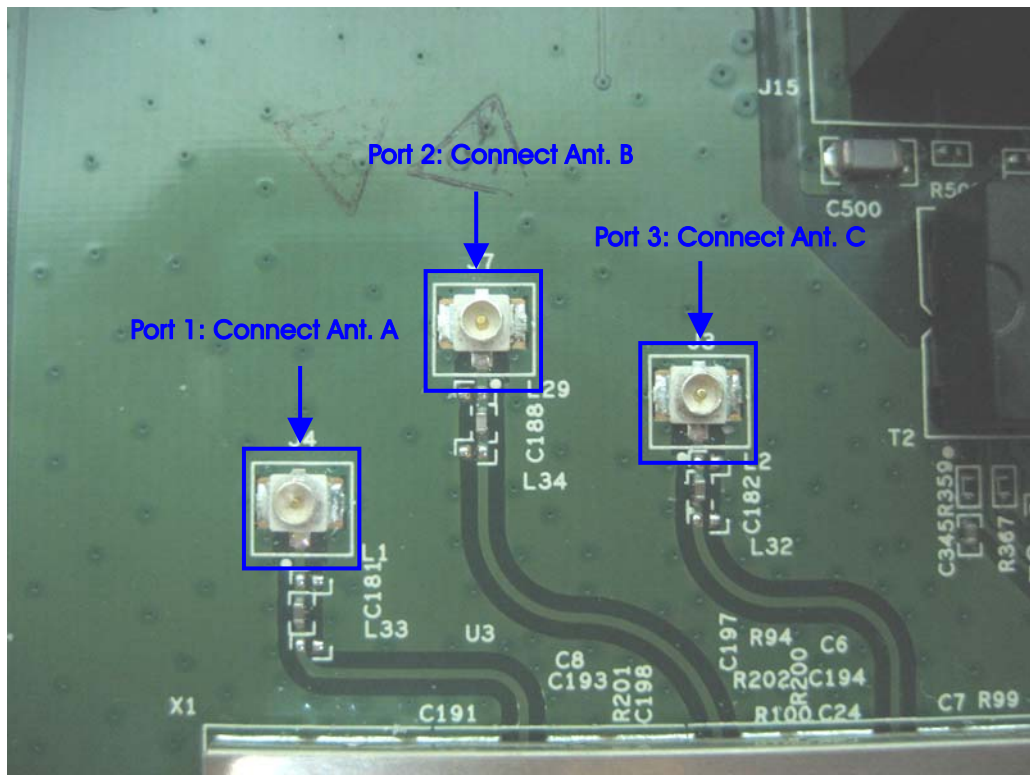

3.4. Table for Carrier Frequencies

There are two bandwidth systems for draft n.

For both 20MHz bandwidth systems, use Channel 1~Channel 11.

For both 40MHz bandwidth systems, use Channel 3~Channel 9.

Frequency Band	Channel No.	Frequency	Channel No.	Frequency
2400~2483.5MHz	1	2412 MHz	7	2442 MHz
	2	2417 MHz	8	2447 MHz
	3	2422 MHz	9	2452 MHz
	4	2427 MHz	10	2457 MHz
	5	2432 MHz	11	2462 MHz
	6	2437 MHz		

3.5. Table for Test Modes

Preliminary tests were performed in different data rate to find the worst radiated emission. The data rate shown in the table below is the worst-case rate with respect to the specific test item. Investigation has been done on all the possible configurations for searching the worst cases. The following table is a list of the test modes shown in this test report.

Test Items	Mode	Channel	Antenna
AC Power Line Conducted Emissions	Normal Link	6	A / B / C
6dB Spectrum Bandwidth	MCS8/20MHz	1/6/11	B / C / B+C
	MCS8/40MHz	3/6/9	B / C / B+C
Maximum Peak Conducted Output Power Power Spectral Density	MCS8/20MHz	1/6/11	B / C / B+C
	MCS8/40MHz	3/6/9	B / C / B+C
Radiated Emissions 9kHz~1GHz	Draft n /BPSK	6	B+C
Radiated Emissions 1GHz~10 th Harmonic	MCS8/20MHz	1/6/11	B+C
	MCS8/40MHz	3/6/9	B+C
Band Edge Emissions	MCS8/20MHz	1/11	B+C
	MCS8/40MHz	3/9	B+C

Note:

Test Mode 1: Ant. A and Ant. B transmit simultaneously.

Test Mode 2: Ant. A and Ant. C transmit simultaneously.

Test Mode 3: Ant. B and Ant. C transmit simultaneously.

Due to Mode 3 generated the worst test result, so it was recorded in this report.

3.6. Table for Testing Locations

Test Site No.	Site Category	Location	FCC Reg. No.	IC File No.	VCCI Reg. No
03CH03-HY	SAC	Hwa Ya	101377	IC 4088	-
CO04-HY	Conduction	Hwa Ya	101377	IC 4088	-
TH01-HY	OVEN Room	Hwa Ya	-	-	-

Open Area Test Site (OATS); Semi Anechoic Chamber (SAC); Fully Anechoic Chamber (FAC).

Please refer section 6 for Test Site Address.

3.7. Table for Supporting Units

Support Unit	Brand	Model	FCC ID
Switching HUB	LANEED	LD-LSW16C/AT	DOC
Notebook	DELL	D400	E2K24GBRL
Notebook	DELL	D505	E2K24GBRL
Notebook	DELL	D400	E2K24GBRL

3.8. Table for Parameters of Test Software Setting

During testing, Channel & Power Controlling Software provided by the customer was used to control the operating channel as well as the output power level. The RF output power selection is for the setting of RF output power expected by the customer and is going to be fixed on the firmware of the final end product.

Power Parameters of Drafft n MCS8 20MHz Ant. B + Ant. C

Test Software Version	Terminal+DOS		
Frequency	2412 MHz	2437 MHz	2462 MHz
Drafft n Ant. B	0X3642	0X3643	0X3845
Drafft n Ant. C	0X3642	0X3643	0X3845

Power Parameters of Drafft n MCS8 40MHz Ant. B + Ant. C

Test Software Version	Terminal+DOS		
Frequency	2422 MHz	2437 MHz	2452 MHz
Drafft n Ant. B	0X3540	0X3542	0X3543
Drafft n Ant. C	0X3540	0X3542	0X3543

During the test, the following programs under WIN XP were executed:

Executed "ping.exe" to link with the remote workstation to receive and transmit data by WLAN.

Executed " Terminal+DOS" to control the EUT continuously transmit RF signal.

3.9. Test Configurations

3.9.1. Radiation Emissions Test Configuration

Test Configuration: 9KHz~1GHz

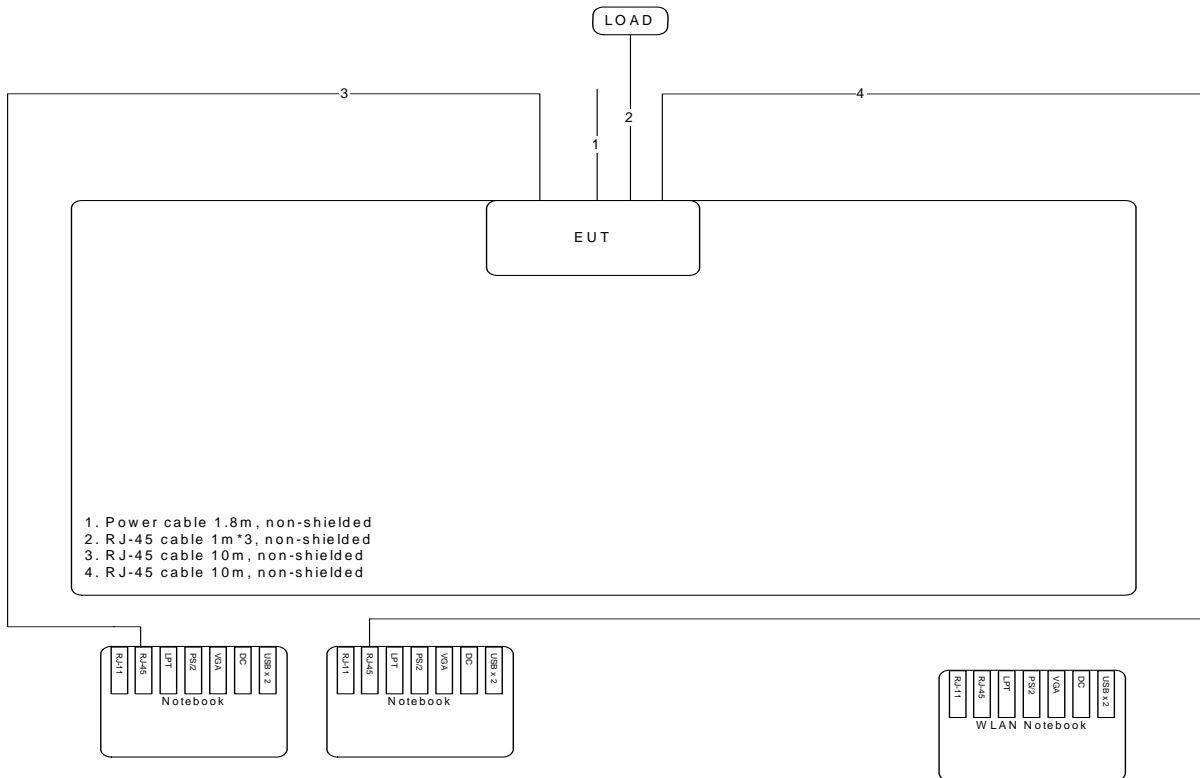

Test Configuration: above 1GHz

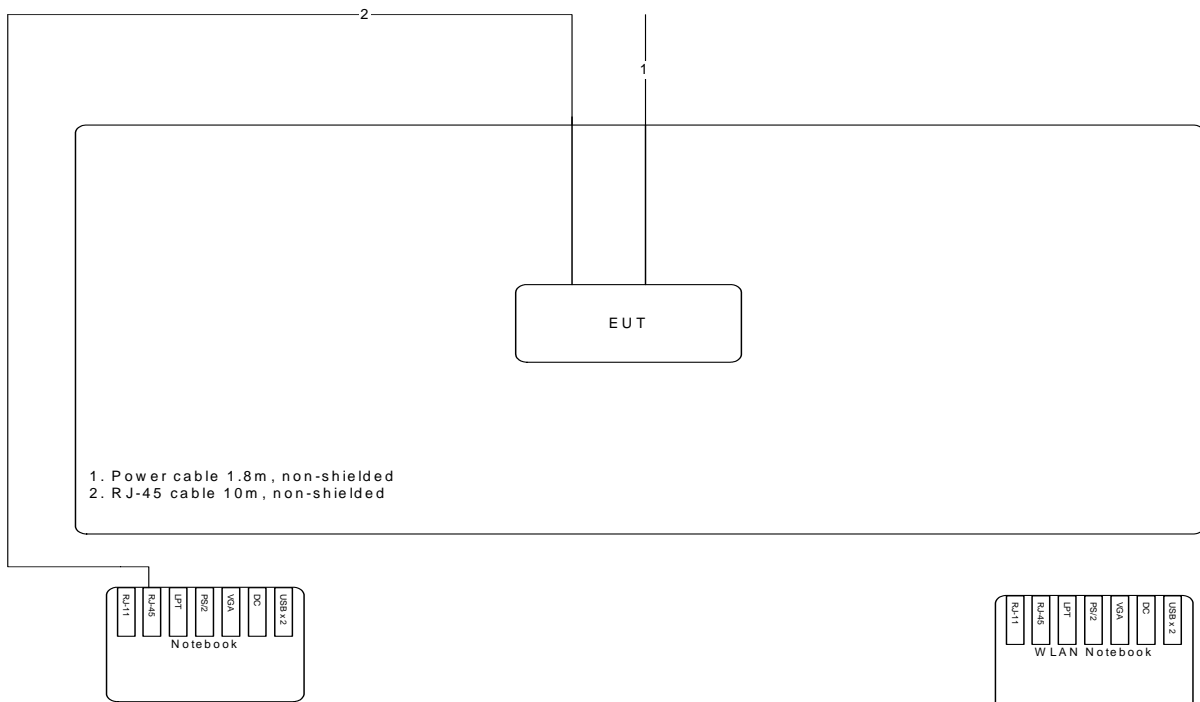

3.9.2. AC Power Line Conduction Emissions Test Configuration

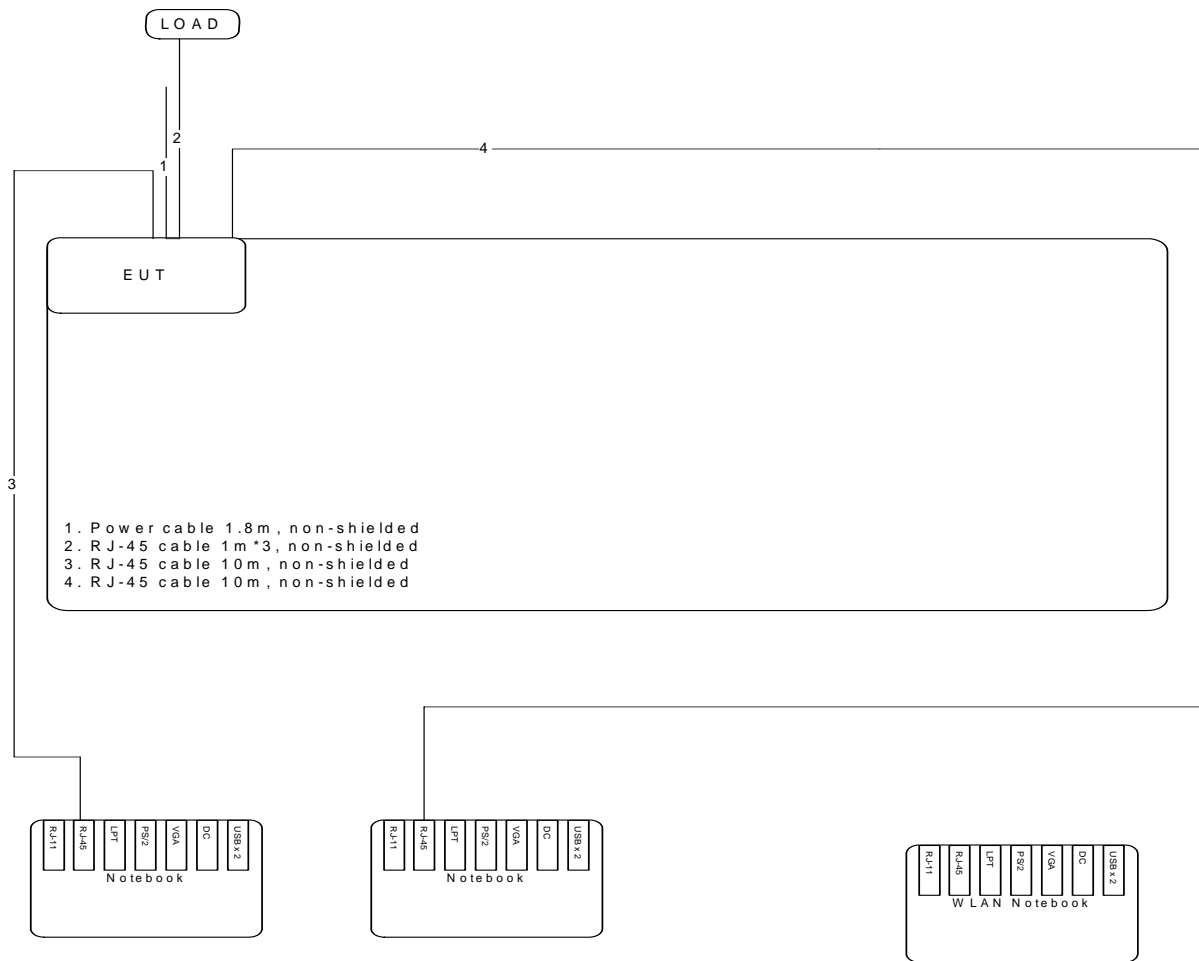

4. TEST RESULT

4.1. AC Power Line Conducted Emissions Measurement

4.1.1. Limit

For this product which is designed to be connected to the AC power line, the radio frequency voltage that is conducted back onto the AC power line on any frequency or frequencies within the band 150 kHz to 30 MHz shall not exceed below limits table.

Frequency (MHz)	QP Limit (dBuV)	AV Limit (dBuV)
0.15~0.5	66~56	56~46
0.5~5	56	46
5~30	60	50

4.1.2. Measuring Instruments and Setting

Please refer to section 5 of equipments list in this report. The following table is the setting of the receiver.

Receiver Parameters	Setting
Attenuation	10 dB
Start Frequency	0.15 MHz
Stop Frequency	30 MHz
IF Bandwidth	9 KHz

4.1.3. Test Procedures

1. Configure the EUT according to ANSI C63.4. The EUT or host of EUT has to be placed 0.4 meter far from the conducting wall of the shielding room and at least 80 centimeters from any other grounded conducting surface.
2. Connect EUT or host of EUT to the power mains through a line impedance stabilization network (LISN).
3. All the support units are connected to the other LISNs. The LISN should provide 50uH/50ohms coupling impedance.
4. The frequency range from 150 KHz to 30 MHz was searched.
5. Set the test-receiver system to Peak Detect Function and Specified Bandwidth with Maximum Hold Mode.
6. The measurement has to be done between each power line and ground at the power terminal.

4.1.4. Test Setup Layout

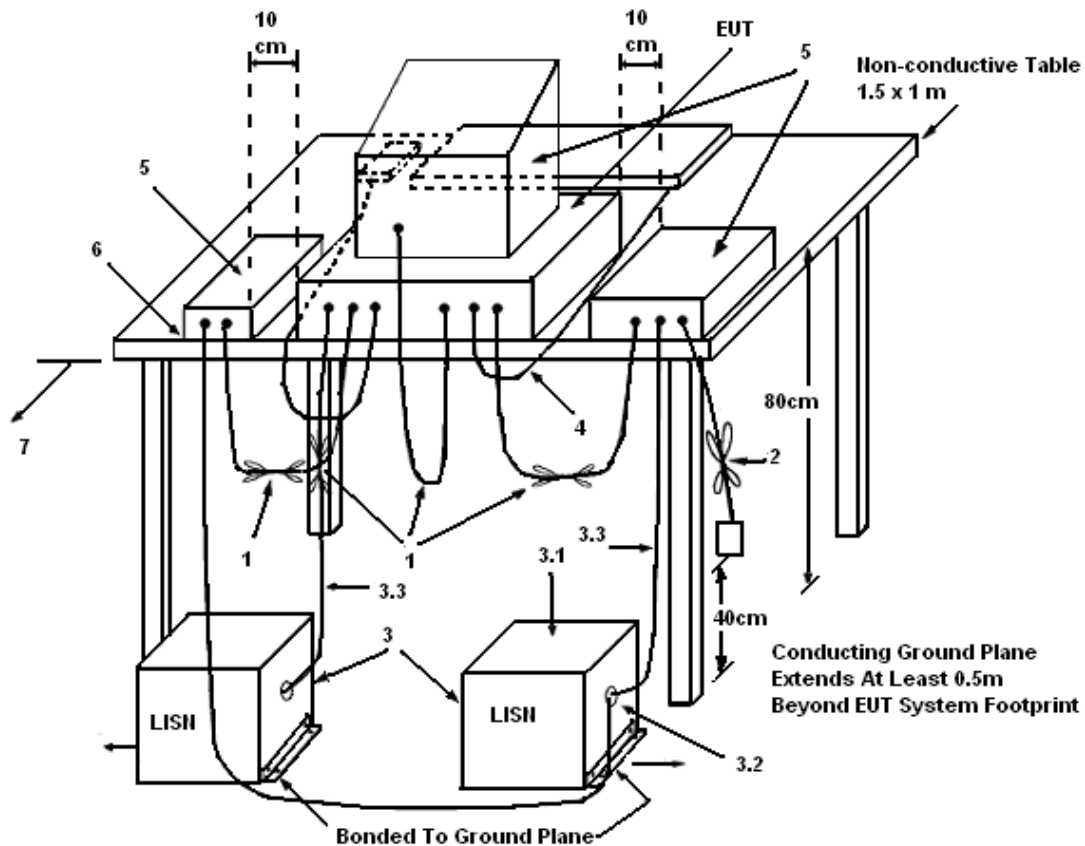

LEGEND:

- (1) Interconnecting cables that hang closer than 40 cm to the ground plane shall be folded back and forth in the center forming a bundle 30 to 40 cm long.
- (2) I/O cables that are not connected to a peripheral shall be bundled in the center. The end of the cable may be terminated, if required, using the correct terminating impedance. The overall length shall not exceed 1 m.
- (3) EUT connected to one LISN. Unused LISN measuring port connectors shall be terminated in 50Ω . LISN can be placed on top of, or immediately beneath, reference ground plane.
 - (3.1) All other equipment powered from additional LISN(s).
 - (3.2) Multiple outlet strip can be used for multiple power cords of non-EUT equipment.
 - (3.3) LISN at least 80 cm from nearest part of EUT chassis.
- (4) Cables of hand-operated devices, such as keyboards, mice, etc., shall be placed as for normal use.
- (5) Non-EUT components of EUT system being tested.
- (6) Rear of EUT, including peripherals, shall all be aligned and flush with rear of tabletop.
- (7) Rear of tabletop shall be 40 cm removed from a vertical conducting plane that is bonded to the ground plane.

4.1.5. Test Deviation

There is no deviation with the original standard.

4.1.6. EUT Operation during Test

The EUT was placed on the test table and programmed in normal function.

4.1.7. Results of AC Power Line Conducted Emissions Measurement

Temperature	26°C	Humidity	59%
Test Engineer	Andy Tsai	Phase	Line
Configuration	Normal Link		

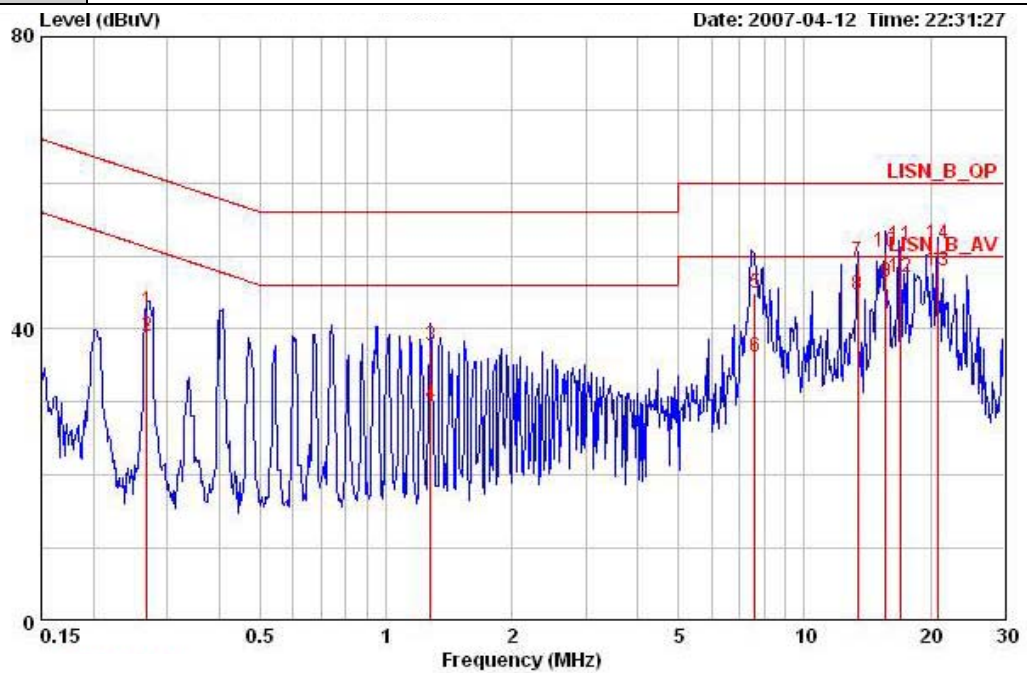

	Freq	Level	Over Limit	Limit Line	Read Level	LISN Factor	Cable Loss	Remark	Pol/Phase
	MHz	dBuV	dB	dBuV	dBuV	dB	dB		
1	0.26809	42.53	-18.65	61.18	42.27	0.06	0.20	QP	LINE
2	0.26809	38.98	-12.20	51.18	38.72	0.06	0.20	AVERAGE	LINE
3	1.275	37.63	-18.37	56.00	37.49	0.00	0.14	QP	LINE
4	1.275	29.66	-16.34	46.00	29.52	0.00	0.14	AVERAGE	LINE
5	7.600	44.82	-15.18	60.00	44.35	0.07	0.40	QP	LINE
6	7.600	36.24	-13.76	50.00	35.77	0.07	0.40	AVERAGE	LINE
7	13.421	49.25	-10.75	60.00	48.75	0.10	0.40	QP	LINE
8	13.421	44.77	-5.23	50.00	44.27	0.10	0.40	AVERAGE	LINE
9	15.618	46.52	-3.48	50.00	46.02	0.10	0.40	AVERAGE	LINE
10	15.618	50.54	-9.46	60.00	50.04	0.10	0.40	QP	LINE
11	16.898	51.43	-8.57	60.00	50.85	0.10	0.48	QP	LINE
12	16.898	47.06	-2.94	50.00	46.48	0.10	0.48	AVERAGE	LINE
13	20.807	47.94	-2.06	50.00	47.32	0.12	0.50	AVERAGE	LINE
14	20.807	51.66	-8.34	60.00	51.04	0.12	0.50	QP	LINE

Temperature	26°C	Humidity	59%
Test Engineer	Andy Tsai	Phase	Neutral
Configuration	Normal Link		

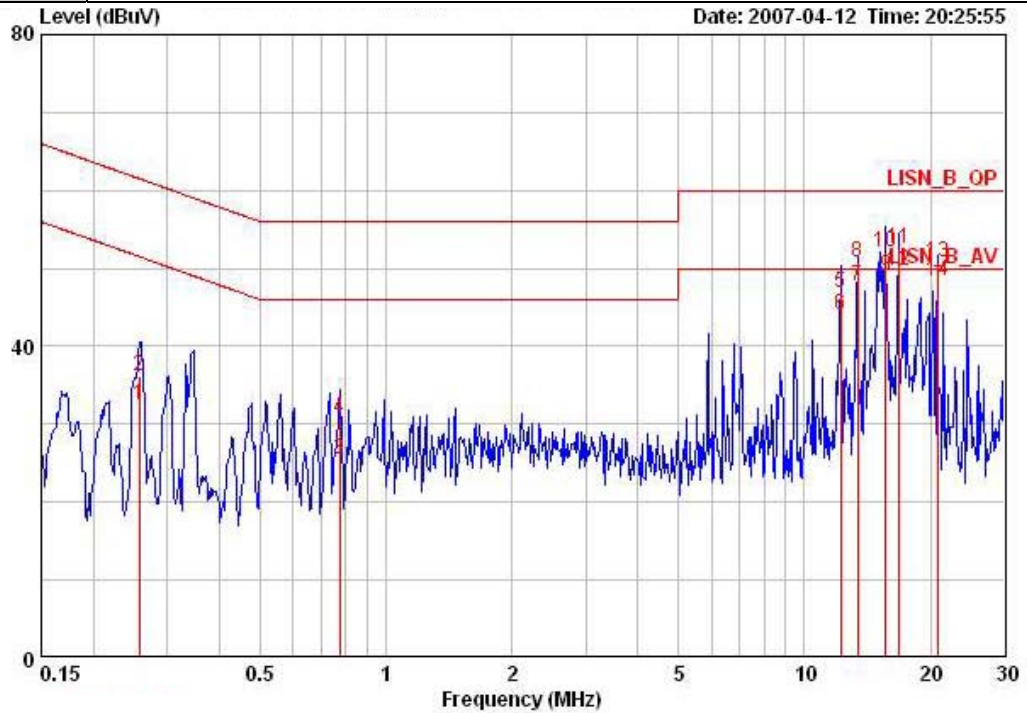

	Freq	Level	Over Limit	Limit Line	Read Level	LISN Factor	Cable Loss	Remark	Pol/Phase
	MHz	dBuV	dB	dBuV	dBuV	dB	dB		
1	0.25786	32.41	-19.09	51.50	32.15	0.06	0.20	AVERAGE	NEUTRAL
2	0.25786	36.17	-25.33	61.50	35.91	0.06	0.20	QP	NEUTRAL
3	0.77519	25.50	-20.50	46.00	25.30	0.00	0.20	AVERAGE	NEUTRAL
4	0.77519	30.81	-25.19	56.00	30.61	0.00	0.20	QP	NEUTRAL
5	12.198	46.95	-13.05	60.00	46.45	0.10	0.40	QP	NEUTRAL
6	12.198	44.05	-5.95	50.00	43.55	0.10	0.40	AVERAGE	NEUTRAL
7	13.420	47.81	-2.19	50.00	47.31	0.10	0.40	AVERAGE	NEUTRAL
8	13.420	50.76	-9.24	60.00	50.26	0.10	0.40	QP	NEUTRAL
9	15.618	49.14	-0.86	50.00	48.64	0.10	0.40	AVERAGE	NEUTRAL
10	15.618	52.05	-7.95	60.00	51.55	0.10	0.40	QP	NEUTRAL
11	16.839	52.45	-7.55	60.00	51.88	0.10	0.47	QP	NEUTRAL
12 (a)	16.839	49.69	-0.31	50.00	49.12	0.10	0.47	AVERAGE	NEUTRAL
13	20.807	50.83	-9.17	60.00	50.21	0.12	0.50	QP	NEUTRAL
14	20.807	48.47	-1.53	50.00	47.85	0.12	0.50	AVERAGE	NEUTRAL

Note:

Level = Read Level + LISN Factor + Cable Loss.

4.2. Maximum Peak Output Power Measurement

4.2.1. Limit

For systems using digital modulation in the 2400-2483.5MHz, the limit for peak output power is 30dBm. The limited has to be reduced by the amount in dB that the gain of the antenna exceed 6dBi. In case of point-to-point operation, the limit has to be reduced by 1dB for every 3dB that the directional gain of the antenna exceeds 6dBi.

4.2.2. Measuring Instruments and Setting

Please refer to section 5 of equipments list in this report. The following table is the setting of the power meter.

Power Meter Parameter	Setting
Filter No.	Auto
Measurement time	0.135 s ~ 26 s
Used Peak Sensor	NRV-Z32 (model 04)

4.2.3. Test Procedures

1. The transmitter output (antenna port) was connected to the power meter.
2. Turn on the EUT and power meter and then record the peak power value.
3. Repeat above procedures on all channels needed to be tested.

4.2.4. Test Setup Layout

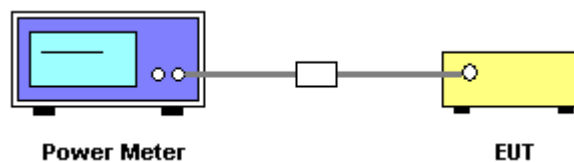

4.2.5. Test Deviation

There is no deviation with the original standard.

4.2.6. EUT Operation during Test

The EUT was programmed to be in continuously transmitting mode.

4.2.7. Test Result of Maximum Peak Output Power

Temperature	23°C	Humidity	62%
Test Engineer	Beck Wu	Configurations	Draft n

Configuration Draft n MCS0 20MHz Ant. B

Channel	Frequency	Conducted Power (dBm)	Max. Limit (dBm)	Result
1	2412 MHz	20.16	30.00	Complies
6	2437 MHz	20.05	30.00	Complies
11	2462 MHz	20.14	30.00	Complies

Configuration Draft n MCS0 20MHz Ant. C

Channel	Frequency	Conducted Power (dBm)	Max. Limit (dBm)	Result
1	2412 MHz	23.22	30.00	Complies
6	2437 MHz	23.27	30.00	Complies
11	2462 MHz	23.13	30.00	Complies

Configuration Draft n MCS8 20MHz Ant. B + Ant. C

Channel	Frequency	Conducted Power (dBm)	Max. Limit (dBm)	Result
1	2412 MHz	24.96	30.00	Complies
6	2437 MHz	24.96	30.00	Complies
11	2462 MHz	24.90	30.00	Complies

Configuration Draft n MCS0 40MHz Ant. B

Channel	Frequency	Conducted Power (dBm)	Max. Limit (dBm)	Result
3	2422 MHz	16.47	30.00	Complies
6	2437 MHz	16.18	30.00	Complies
9	2452 MHz	17.25	30.00	Complies

Configuration Draft n MCS0 40MHz Ant. C

Channel	Frequency	Conducted Power (dBm)	Max. Limit (dBm)	Result
3	2422 MHz	19.81	30.00	Complies
6	2437 MHz	19.43	30.00	Complies
9	2452 MHz	19.55	30.00	Complies

Configuration Draft n MCS8 40MHz Ant. B + Ant. C

Channel	Frequency	Conducted Power (dBm)	Max. Limit (dBm)	Result
3	2422 MHz	21.46	30.00	Complies
6	2437 MHz	21.11	30.00	Complies
9	2452 MHz	21.56	30.00	Complies

4.3. Power Spectral Density Measurement

4.3.1. Limit

For digitally modulated systems, the power spectral density conducted from the intentional radiator to the antenna shall not be greater than 8 dBm in any 3 kHz band during any time interval of continuous transmission.

4.3.2. Measuring Instruments and Setting

Please refer to section 5 of equipments list in this report. The following table is the setting of Spectrum Analyzer.

Spectrum Parameter	Setting
Attenuation	Auto
Span Frequency	1.5MHz
RB	3 kHz
VB	30 kHz
Detector	Peak
Trace	Max Hold
Sweep Time	500s

4.3.3. Test Procedures

1. The transmitter output (antenna port) was connected to the spectrum analyser.
2. Set RBW of spectrum analyzer to 3kHz and VBW to 30kHz. Set Detector to Peak, Trace to Max Hold.
3. Mark the frequency with maximum peak power as the center of the display of the spectrum.
4. Set the span to 1.5MHz and the sweep time to 500s and record the maximum peak value.

4.3.4. Test Setup Layout

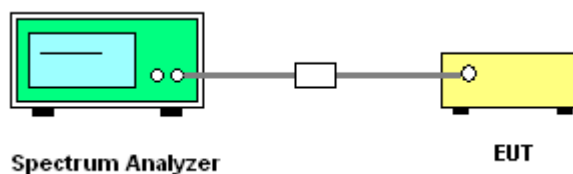

4.3.5. Test Deviation

There is no deviation with the original standard.

4.3.6. EUT Operation during Test

The EUT was programmed to be in continuously transmitting mode.

4.3.7. Test Result of Power Spectral Density

Temperature	23°C	Humidity	62%
Test Engineer	Beck Wu	Configurations	Draft n

Configuration Draft n MCS0 20MHz Ant. B

Channel	Frequency	Power Density (dBm)	Max. Limit (dBm)	Result
1	2412 MHz	-14.60	8.00	Complies
6	2437 MHz	-13.01	8.00	Complies
11	2462 MHz	-14.86	8.00	Complies

Configuration Draft n MCS0 20MHz Ant. C

Channel	Frequency	Power Density (dBm)	Max. Limit (dBm)	Result
1	2412 MHz	-11.72	8.00	Complies
6	2437 MHz	-12.28	8.00	Complies
11	2462 MHz	-11.25	8.00	Complies

Configuration Draft n MCS8 20MHz Ant. B + Ant. C

Channel	Frequency	Power Density (dBm)	Max. Limit (dBm)	Result
1	2412 MHz	-6.31	8.00	Complies
6	2437 MHz	-5.30	8.00	Complies
11	2462 MHz	-7.13	8.00	Complies

Configuration Draft n MCS0 40MHz Ant. B

Channel	Frequency	Power Density (dBm)	Max. Limit (dBm)	Result
3	2422 MHz	-16.62	8.00	Complies
6	2437 MHz	-17.53	8.00	Complies
9	2452 MHz	-17.20	8.00	Complies

Configuration Draft n MCS0 40MHz Ant. C

Channel	Frequency	Power Density (dBm)	Max. Limit (dBm)	Result
3	2422 MHz	-14.06	8.00	Complies
6	2437 MHz	-14.75	8.00	Complies
9	2452 MHz	-14.78	8.00	Complies

Configuration Draft n MCS8 40MHz Ant. B + Ant. C

Channel	Frequency	Power Density (dBm)	Max. Limit (dBm)	Result
3	2422 MHz	-8.35	8.00	Complies
6	2437 MHz	-8.84	8.00	Complies
9	2452 MHz	-7.73	8.00	Complies

Power Density Plot on Configuration Drafft n MCS0 20MHz Ant. B / 2412 MHz

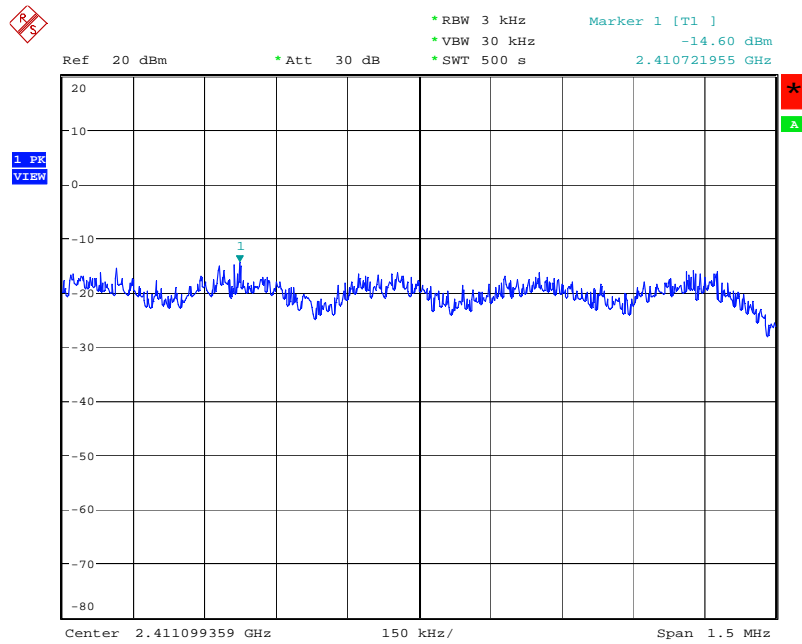

Date: 23.MAY.2007 14:58:35

Power Density Plot on Configuration Drafft n MCS0 20MHz Ant. B / 2437 MHz

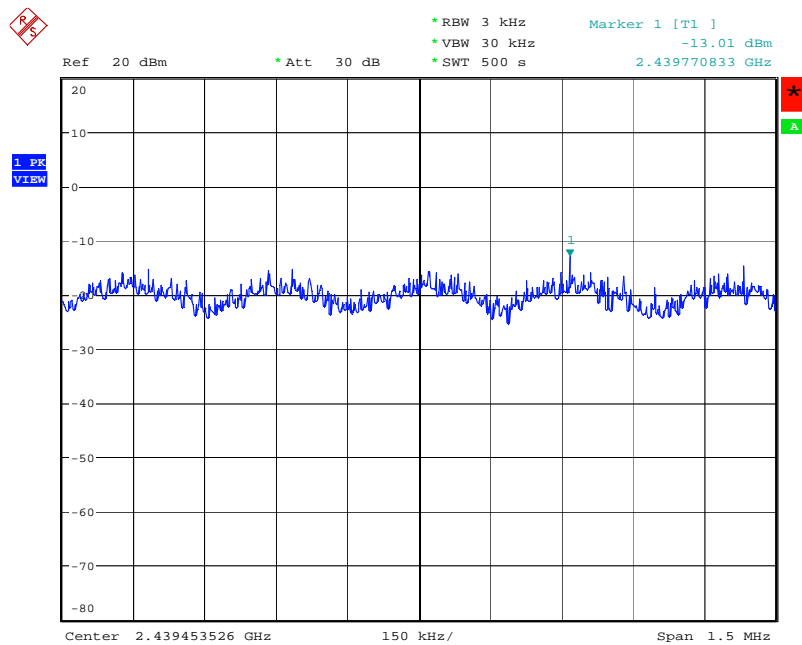

Date: 23.MAY.2007 15:01:16

Power Density Plot on Configuration Drafft n MCS0 20MHz Ant. B / 2462 MHz

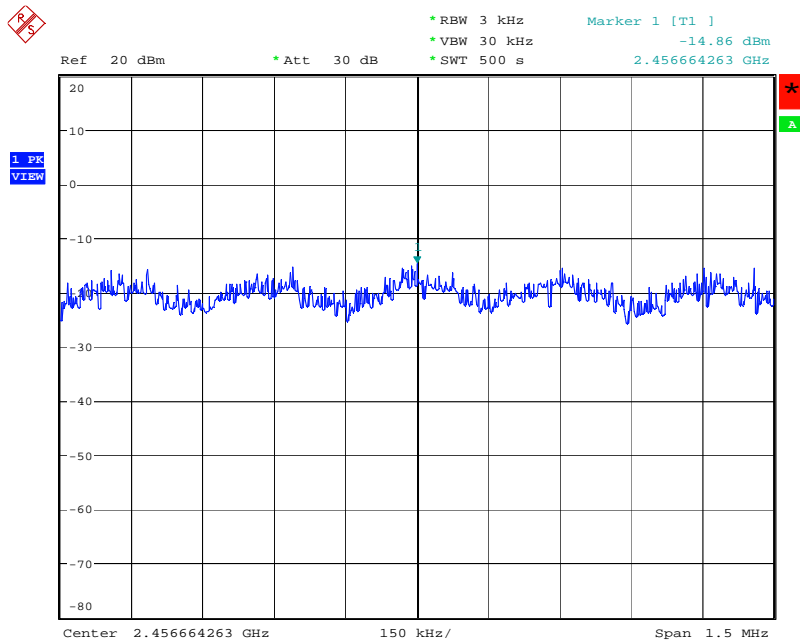

Date: 23.MAY.2007 15:02:54

Power Density Plot on Configuration Drafft n MCS0 20MHz Ant. C / 2412 MHz

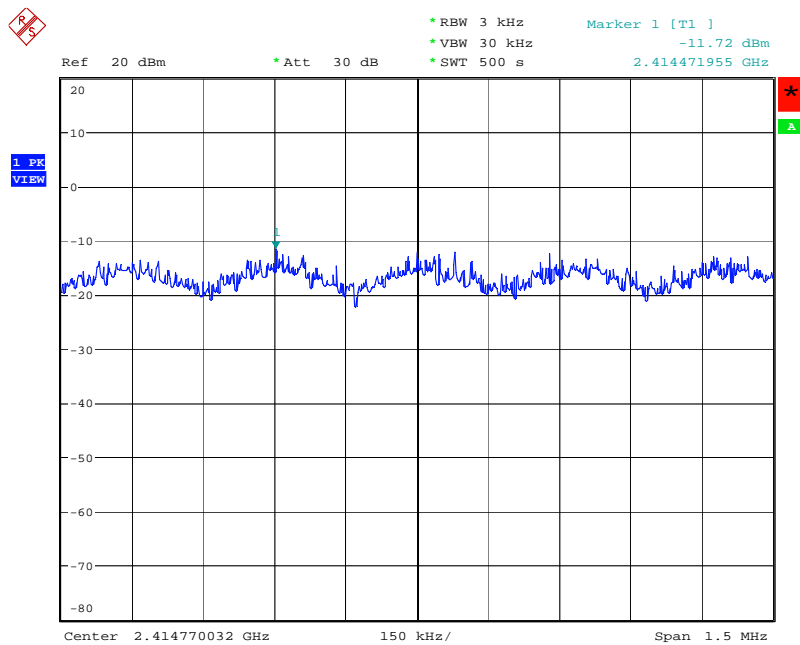

Date: 23.MAY.2007 14:45:18

Power Density Plot on Configuration Drafft n MCS0 20MHz Ant. C / 2437 MHz

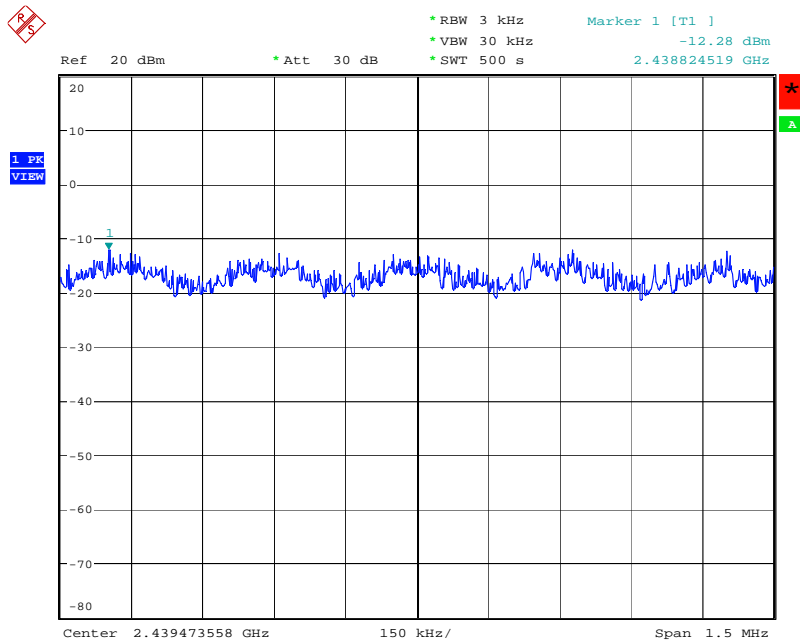

Date: 23.MAY.2007 14:43:48

Power Density Plot on Configuration Drafft n MCS0 20MHz Ant. C / 2462 MHz

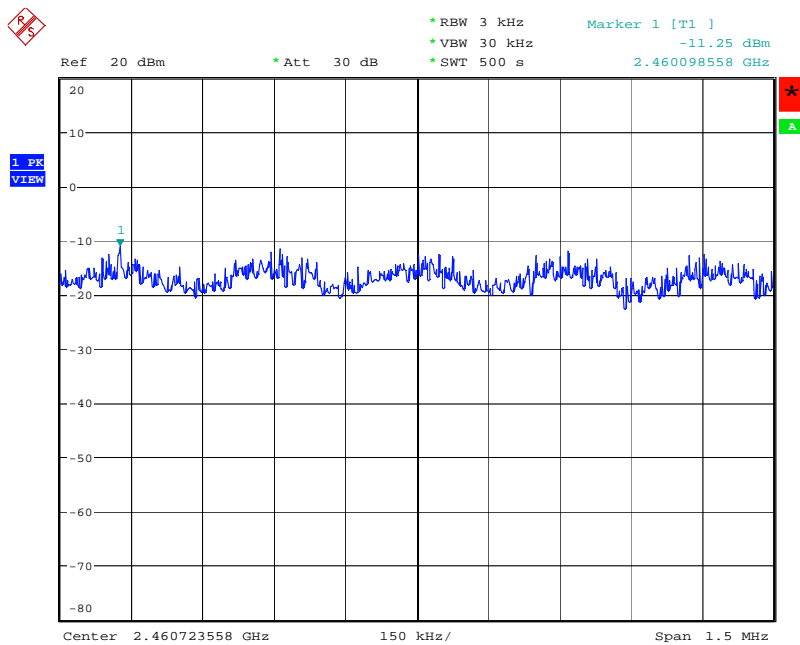

Date: 23.MAY.2007 14:40:36

Power Density Plot on Configuration Drafft n MCS8 20MHz Ant. B + Ant. C / 2412 MHz

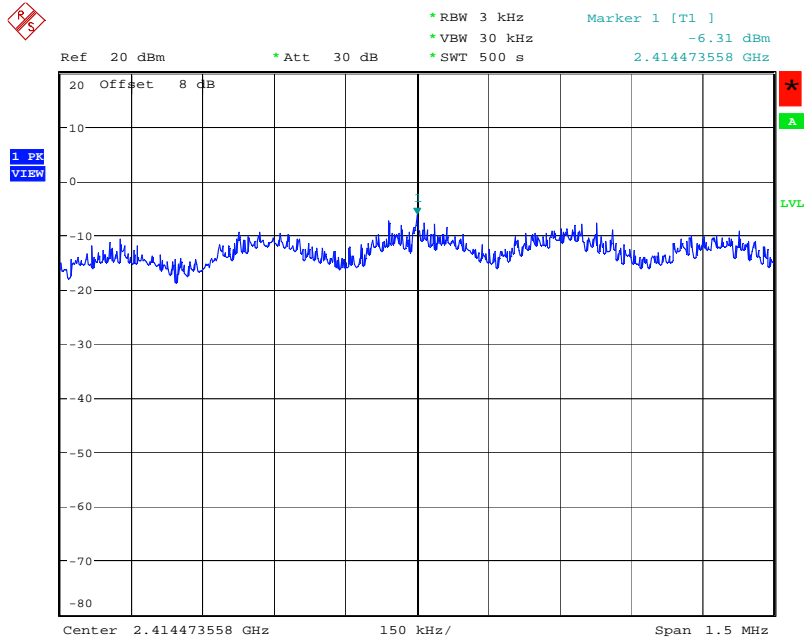

Date: 23.MAY.2007 17:07:44

Power Density Plot on Configuration Drafft n MCS8 20MHz Ant. B + Ant. C / 2437 MHz

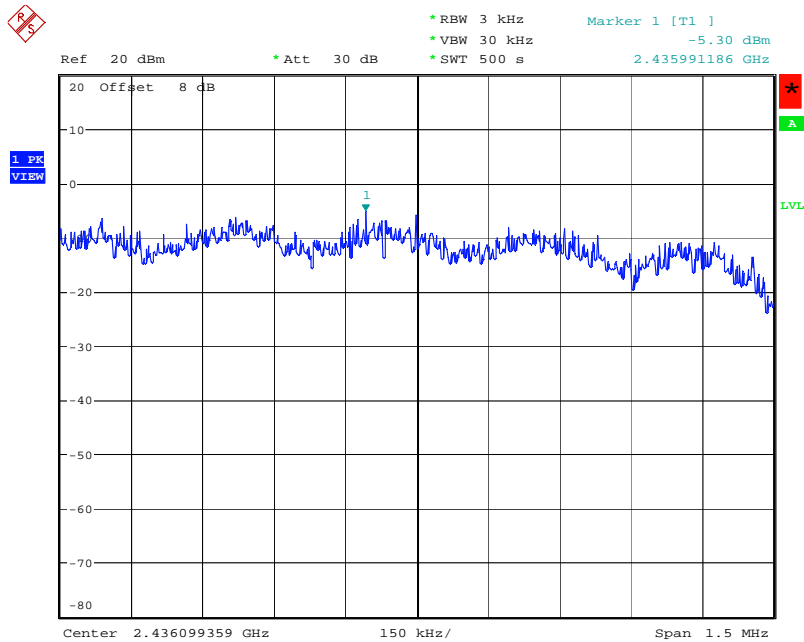

Date: 23.MAY.2007 17:06:04

Power Density Plot on Configuration Draff n MCS8 20MHz Ant. B + Ant. C / 2462 MHz

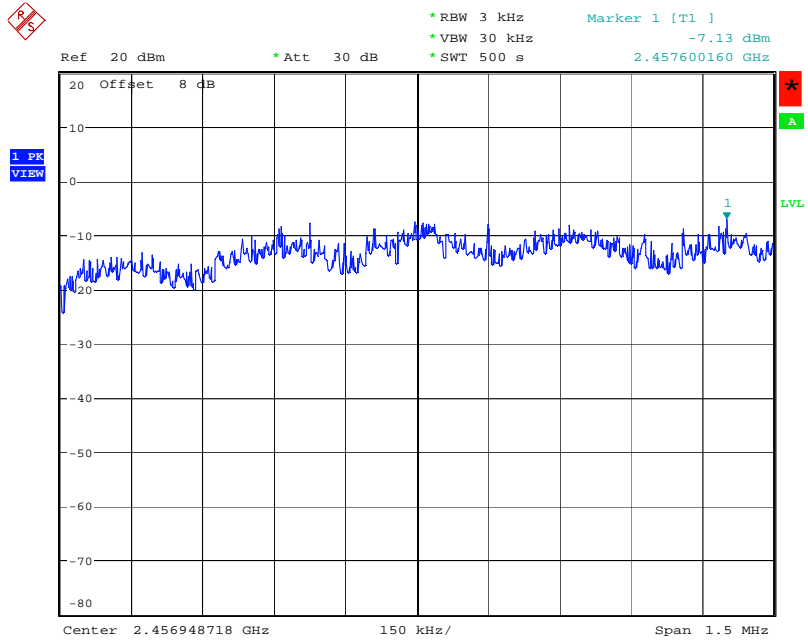

Date: 23.MAY.2007 17:04:43

Power Density Plot on Configuration Draff n MCS0 40MHz Ant. B / 2422 MHz

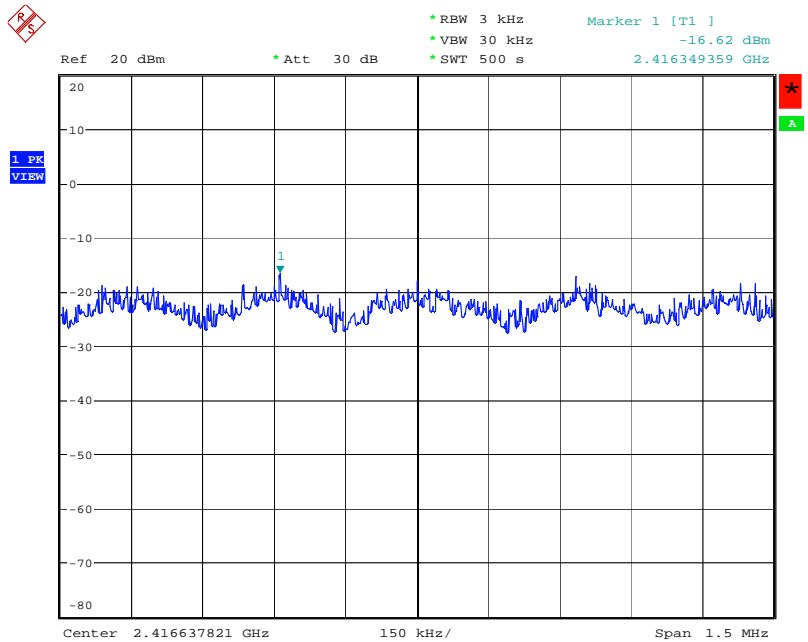

Date: 23.MAY.2007 15:09:58

Power Density Plot on Configuration Drafft n MCS0 40MHz Ant. B / 2437 MHz

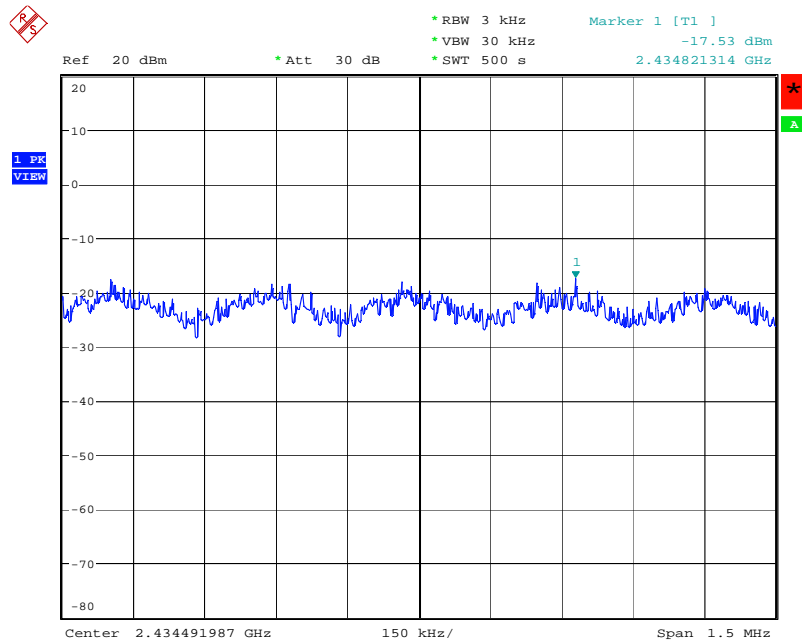

Date: 23.MAY.2007 15:11:24

Power Density Plot on Configuration Drafft n MCS0 40MHz Ant. B / 2452 MHz

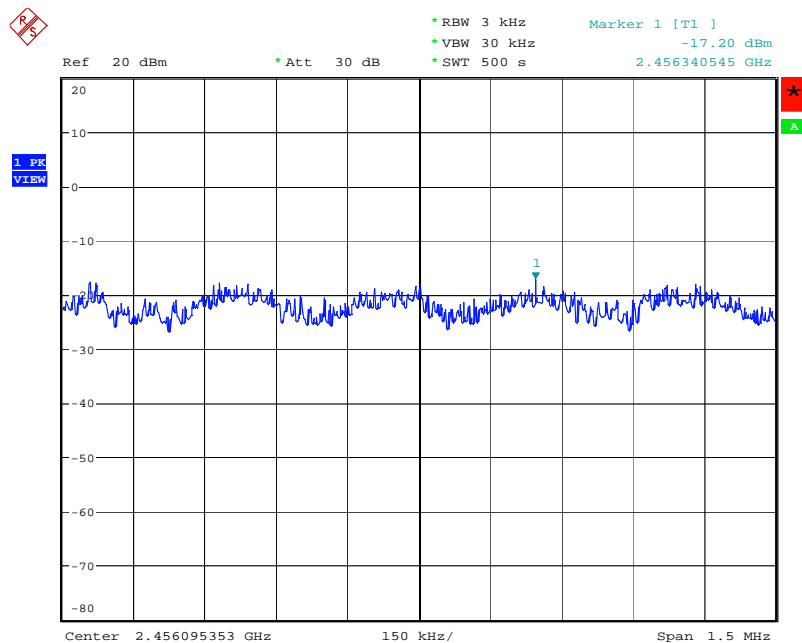

Date: 23.MAY.2007 15:15:14

Power Density Plot on Configuration Drafft n MCS0 40MHz Ant. C / 2422 MHz

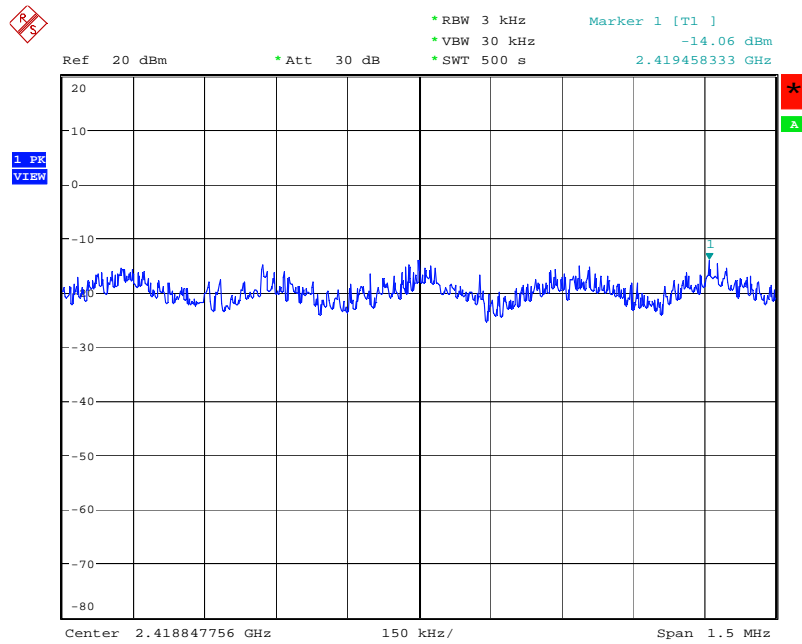

Date: 23.MAY.2007 15:38:45

Power Density Plot on Configuration Drafft n MCS0 40MHz Ant. C / 2437 MHz

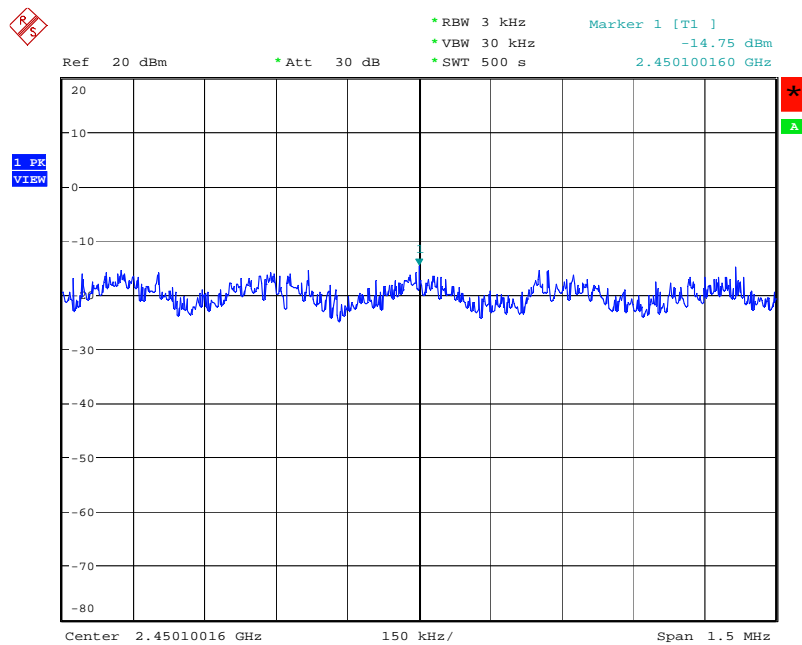

Date: 23.MAY.2007 15:37:29

Power Density Plot on Configuration Drafft n MCS0 40MHz Ant. C / 2452 MHz

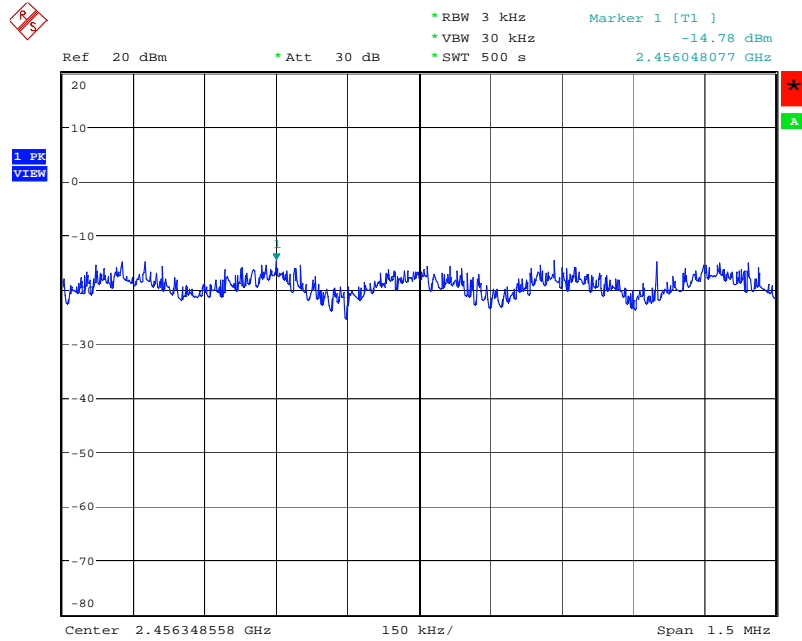

Date: 23.MAY.2007 15:36:03

Power Density Plot on Configuration Drafft n MCS8 40MHz Ant. B + Ant. C / 2422 MHz

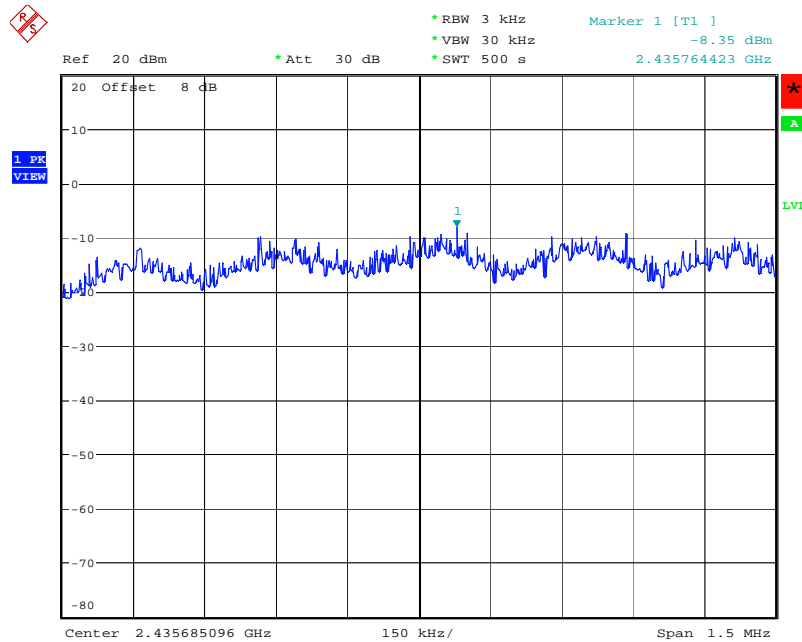

Date: 23.MAY.2007 16:45:53

Power Density Plot on Configuration Draft n MCS8 40MHz Ant. B + Ant. C / 2437 MHz

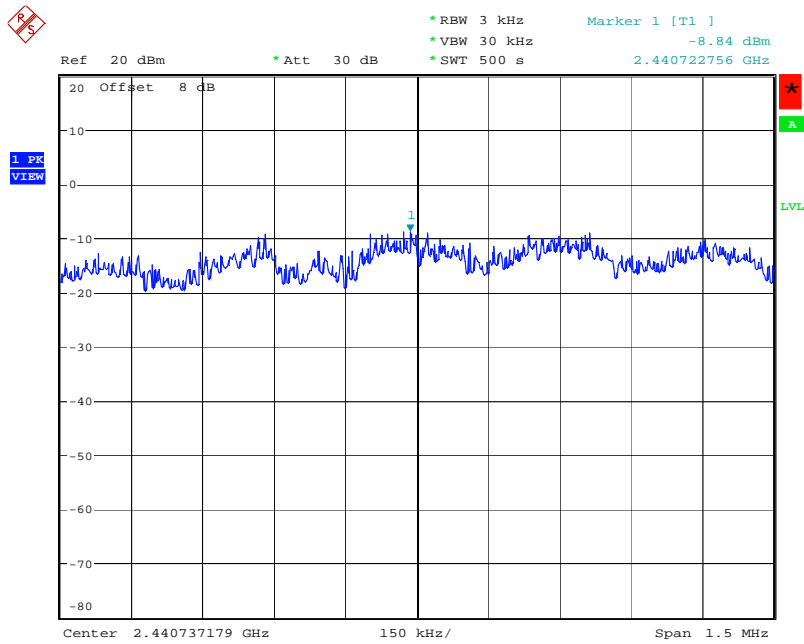

Date: 23.MAY.2007 16:44:31

Power Density Plot on Configuration Draft n MCS8 40MHz Ant. B + Ant. C / 2452 MHz

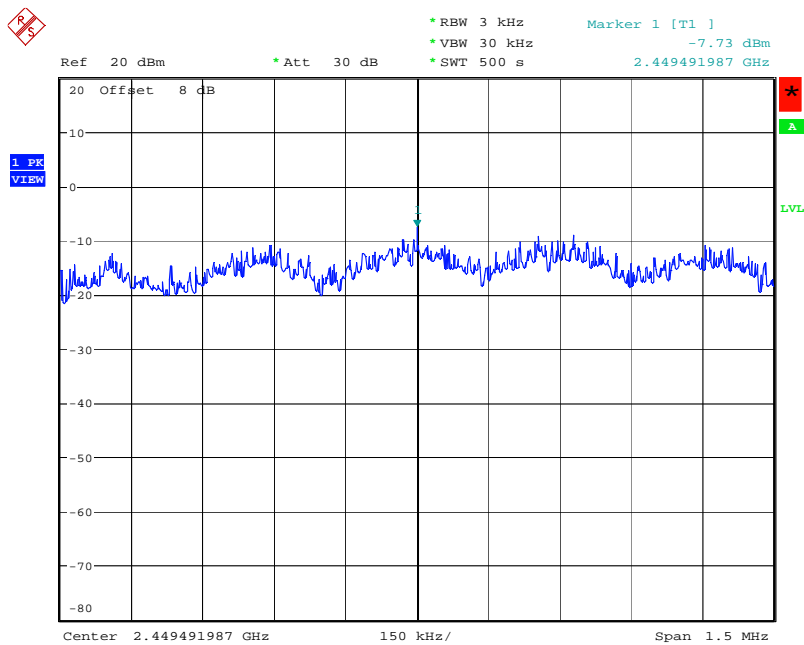

Date: 23.MAY.2007 16:43:06

4.4. 6dB Spectrum Bandwidth Measurement

4.4.1. Limit

For digital modulation systems, the minimum 6 dB bandwidth shall be at least 500 kHz.

4.4.2. Measuring Instruments and Setting

Please refer to section 5 of equipments list in this report. The following table is the setting of the Spectrum Analyzer.

Spectrum Parameters	Setting
Attenuation	Auto
Span Frequency	> 6dB Bandwidth
RB	100 kHz
VB	100 kHz
Detector	Peak
Trace	Max Hold
Sweep Time	Auto

4.4.3. Test Procedures

1. The transmitter output (antenna port) was connected to the spectrum analyser in peak hold mode.
2. The resolution bandwidth of 100 kHz and the video bandwidth of 100 kHz were used.
3. Measured the spectrum width with power higher than 6dB below carrier.

4.4.4. Test Setup Layout

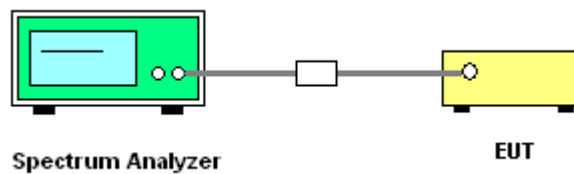

4.4.5. Test Deviation

There is no deviation with the original standard.

4.4.6. EUT Operation during Test

The EUT was programmed to be in continuously transmitting mode.

4.4.7. Test Result of 6dB Spectrum Bandwidth

Temperature	23°C	Humidity	62%
Test Engineer	Beck Wu	Configurations	Draft n

Configuration Draft n MCS0 20MHz Ant. B

Channel	Frequency	6dB Bandwidth (MHz)	99% Occupied Bandwidth (MHz)	Min. Limit (kHz)	Test Result
1	2412 MHz	16.95	17.46	500	Complies
6	2437 MHz	16.82	17.46	500	Complies
11	2462 MHz	16.79	17.46	500	Complies

Configuration Draft n MCS0 20MHz Ant. C

Channel	Frequency	6dB Bandwidth (MHz)	99% Occupied Bandwidth (MHz)	Min. Limit (kHz)	Test Result
1	2412 MHz	17.24	17.50	500	Complies
6	2437 MHz	16.82	17.46	500	Complies
11	2462 MHz	17.11	17.46	500	Complies

Configuration Draft n MCS8 20MHz Ant. B + Ant. C

Channel	Frequency	6dB Bandwidth (MHz)	99% Occupied Bandwidth (MHz)	Min. Limit (kHz)	Test Result
1	2412 MHz	15.73	16.82	500	Complies
6	2437 MHz	15.28	17.59	500	Complies
11	2462 MHz	15.73	16.98	500	Complies

Configuration Draft n MCS0 40MHz Ant. B

Channel	Frequency	6dB Bandwidth (MHz)	99% Occupied Bandwidth (MHz)	Min. Limit (kHz)	Test Result
3	2422 MHz	35.57	36.08	500	Complies
6	2437 MHz	35.96	36.08	500	Complies
9	2452 MHz	35.32	36.08	500	Complies

Configuration Draft n MCS0 40MHz Ant. C

Channel	Frequency	6dB Bandwidth (MHz)	99% Occupied Bandwidth (MHz)	Min. Limit (kHz)	Test Result
3	2422 MHz	35.96	36.08	500	Complies
6	2437 MHz	35.70	36.02	500	Complies
9	2452 MHz	35.96	36.08	500	Complies

Configuration Draft n MCS8 40MHz Ant. B + Ant. C

Channel	Frequency	6dB Bandwidth (MHz)	99% Occupied Bandwidth (MHz)	Min. Limit (kHz)	Test Result
3	2422 MHz	33.20	35.70	500	Complies
6	2437 MHz	33.26	35.44	500	Complies
9	2452 MHz	35.19	36.02	500	Complies

6 dB Bandwidth Plot on Configuration Draft n MCS0 20MHz Ant. B / 2412 MHz

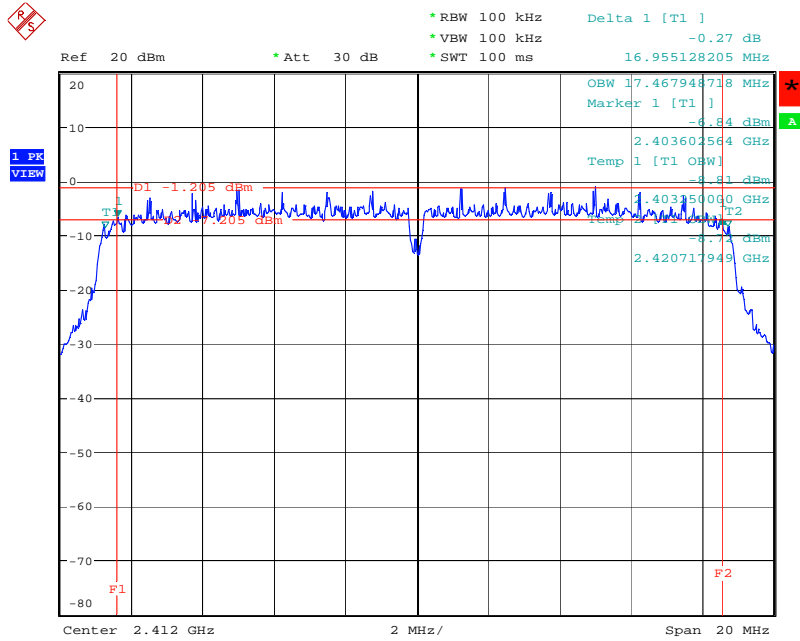

Date: 23.MAY.2007 14:58:10

6 dB Bandwidth Plot on Configuration Draft n MCS0 20MHz Ant. B / 2437 MHz

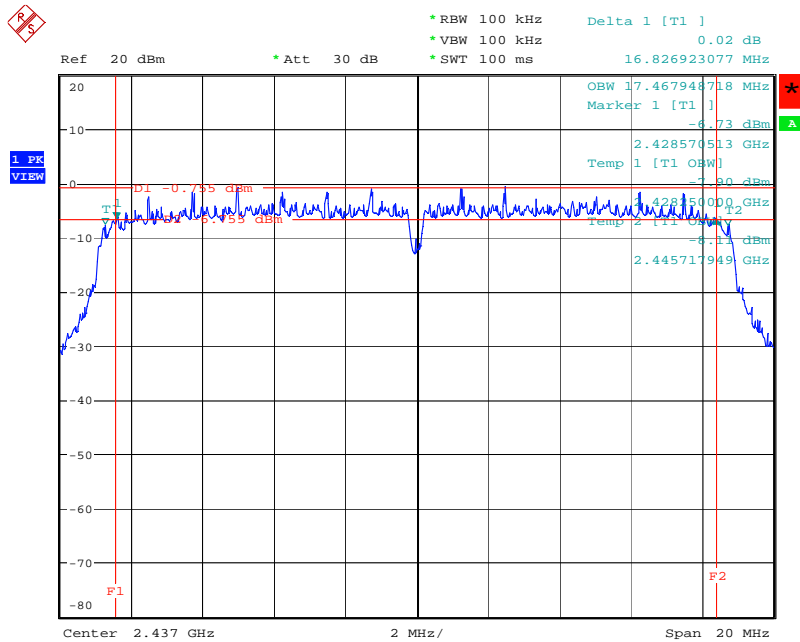

Date: 23.MAY.2007 15:00:59

6 dB Bandwidth Plot on Configuration Draft n MCS0 20MHz Ant. B / 2462 MHz

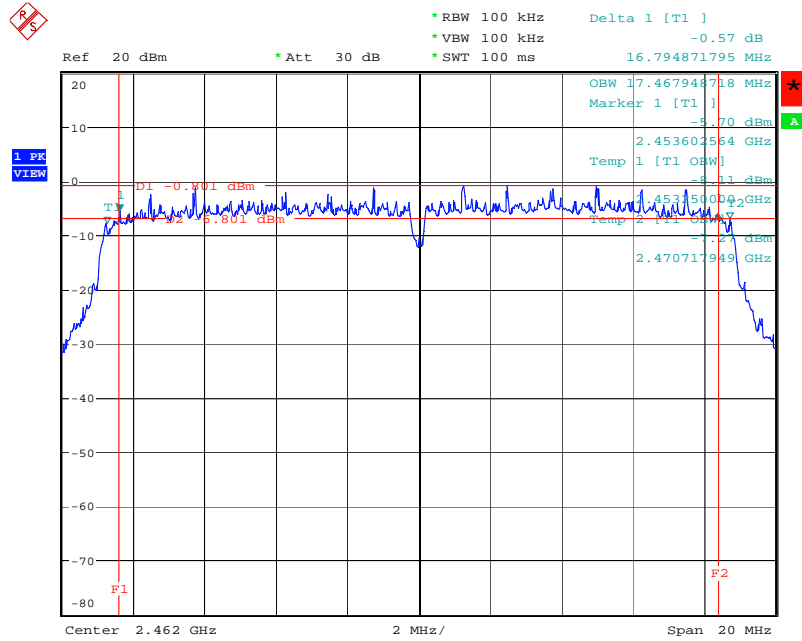

Date: 23.MAY.2007 15:02:38

6 dB Bandwidth Plot on Configuration Draft n MCS0 20MHz Ant. C / 2412 MHz

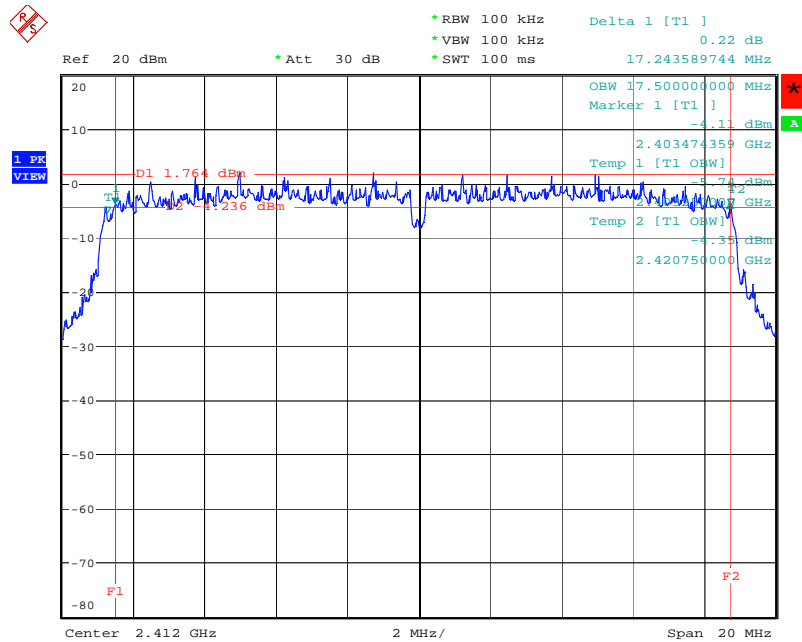

Date: 23.MAY.2007 14:44:53

6 dB Bandwidth Plot on Configuration Draft n MCS0 20MHz Ant. C / 2437 MHz

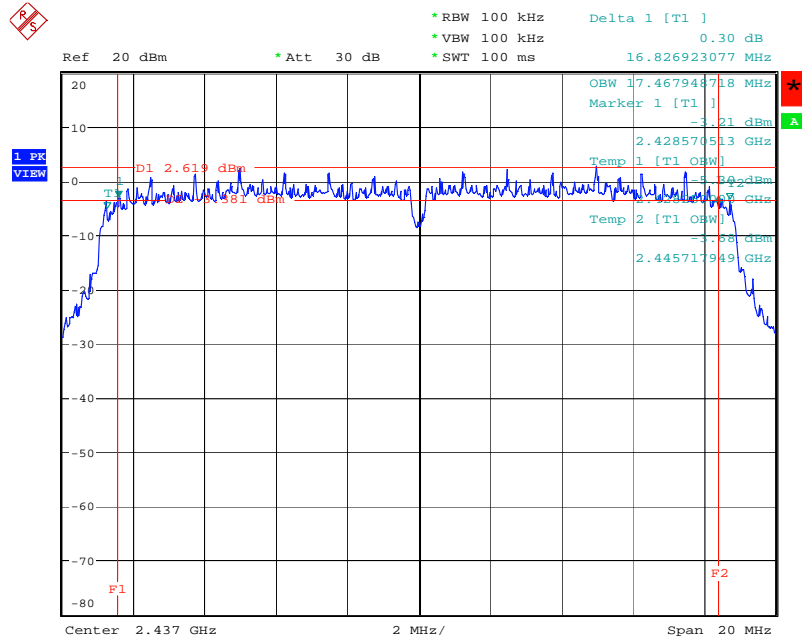

Date: 23.MAY.2007 14:43:31

6 dB Bandwidth Plot on Configuration Draft n MCS0 20MHz Ant. C / 2462 MHz

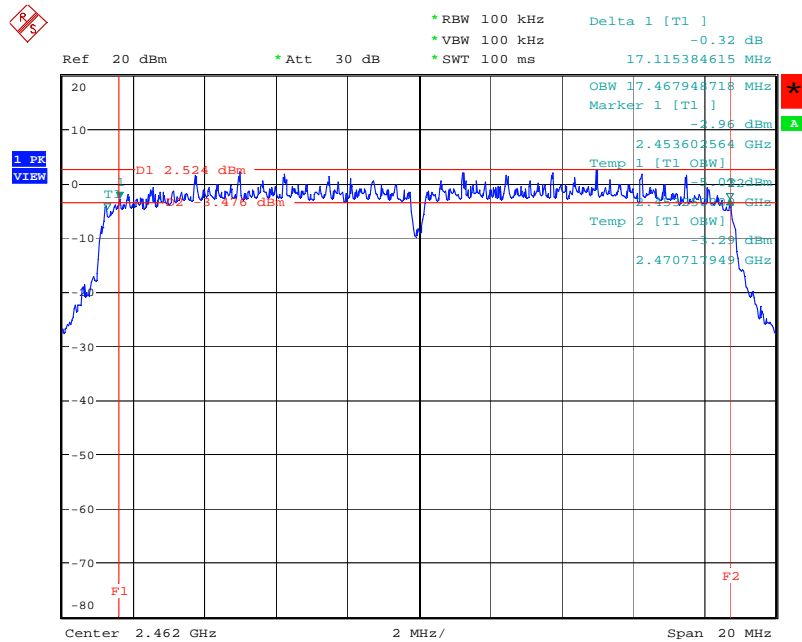

Date: 23.MAY.2007 14:40:21

6 dB Bandwidth Plot on Configuration Draft n MCS8 20MHz Ant. B + Ant. C / 2412 MHz

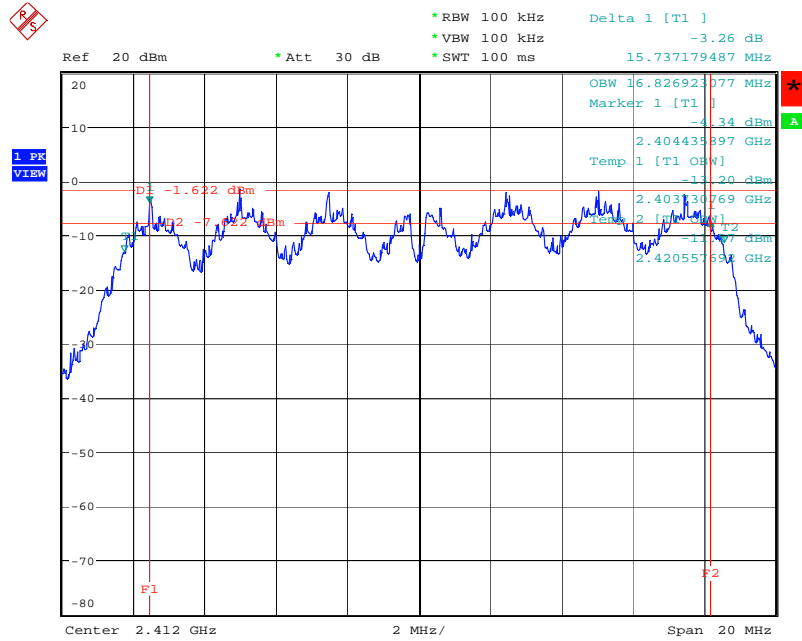

Date: 23.MAY.2007 17:07:19

6 dB Bandwidth Plot on Configuration Draft n MCS8 20MHz Ant. B + Ant. C / 2437 MHz

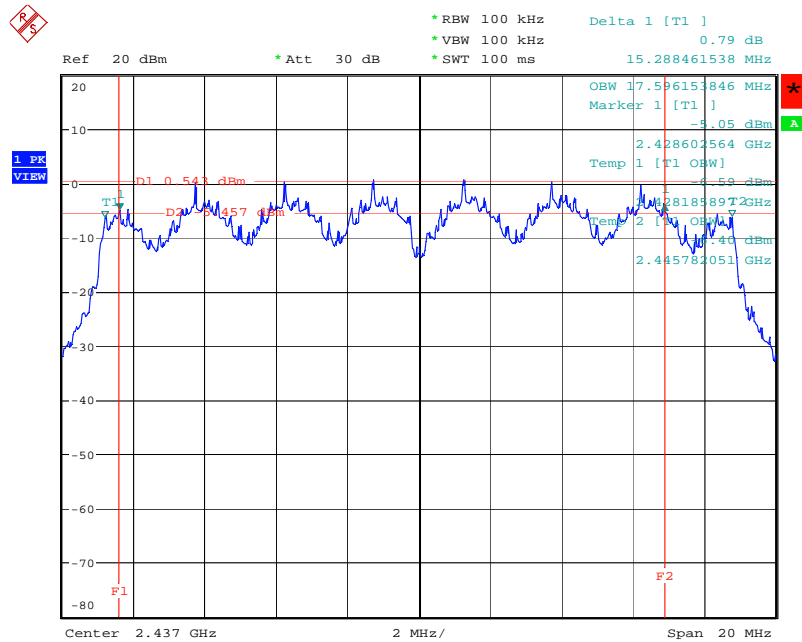

Date: 23.MAY.2007 17:05:47

6 dB Bandwidth Plot on Configuration Drafft n MCS8 20MHz Ant. B + Ant. C / 2462 MHz

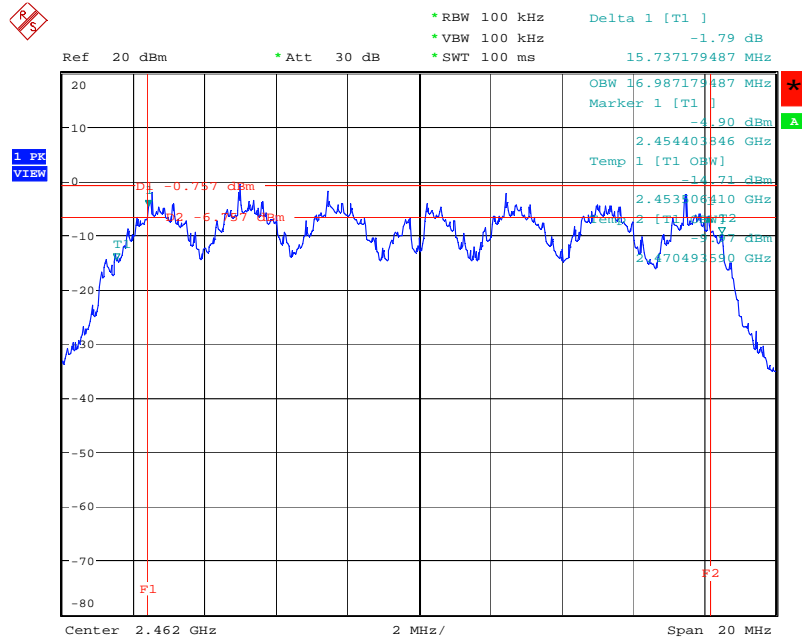

Date: 23.MAY.2007 17:04:27

6 dB Bandwidth Plot on Configuration Drafft n MCS0 40MHz Ant. B / 2422 MHz

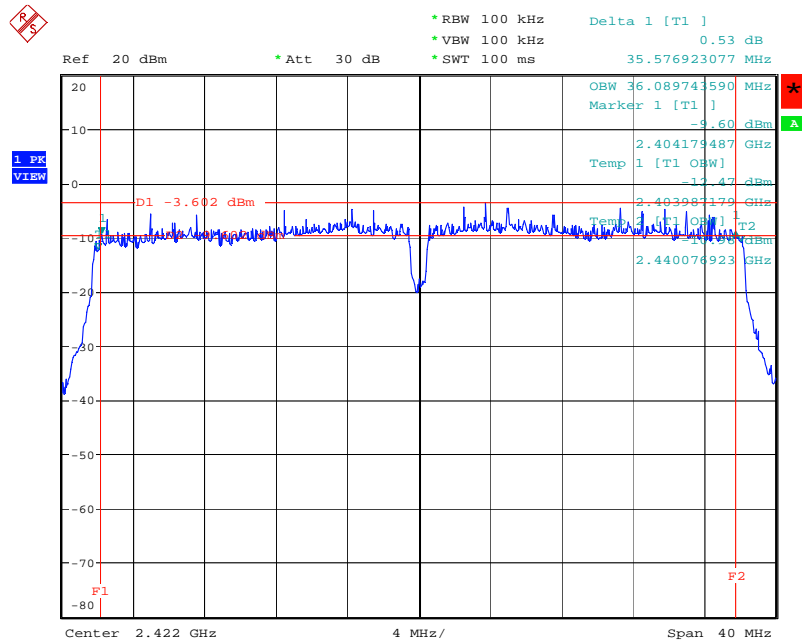

Date: 23.MAY.2007 15:09:32

6 dB Bandwidth Plot on Configuration Draft n MCS0 40MHz Ant. B / 2437 MHz

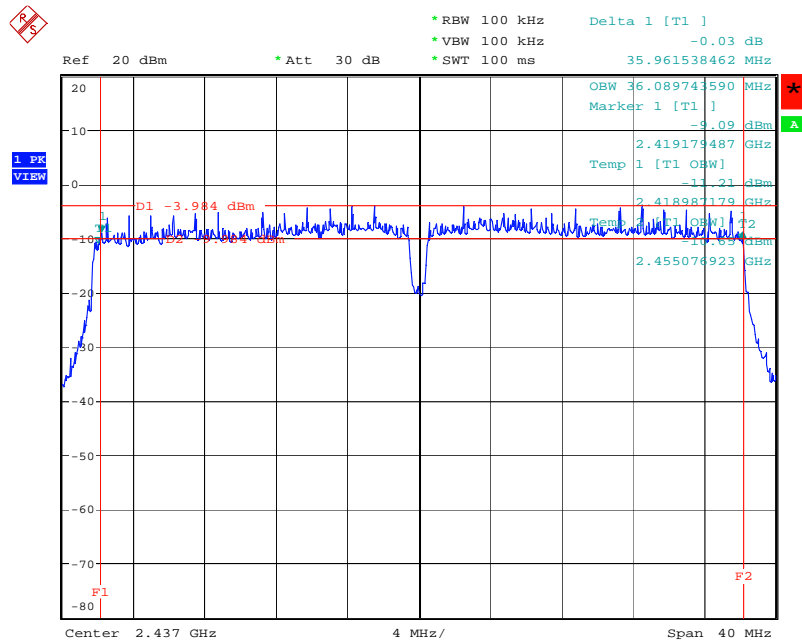

Date: 23.MAY.2007 15:10:58

6 dB Bandwidth Plot on Configuration Draft n MCS0 40MHz Ant. B / 2452 MHz

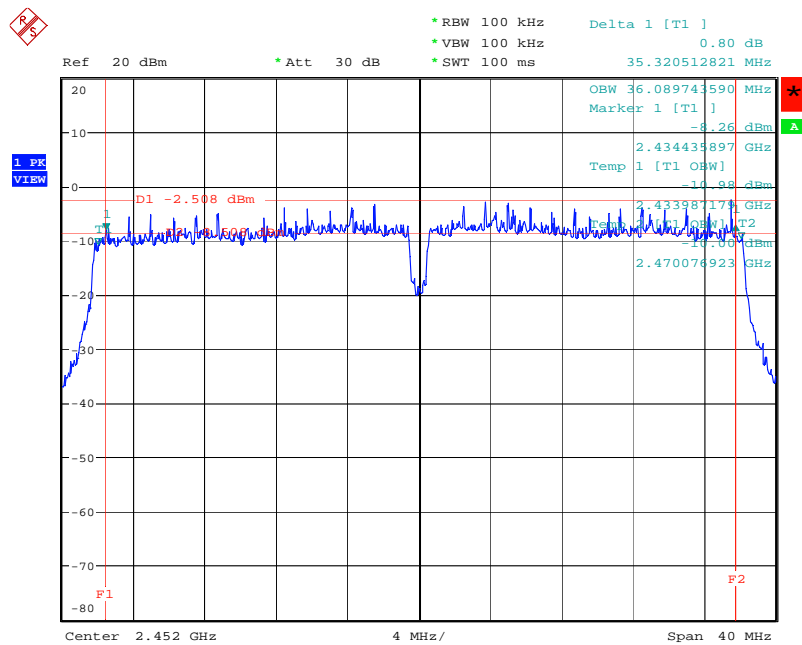

Date: 23.MAY.2007 15:14:49

6 dB Bandwidth Plot on Configuration Draft n MCS8 40MHz Ant. C / 2422 MHz

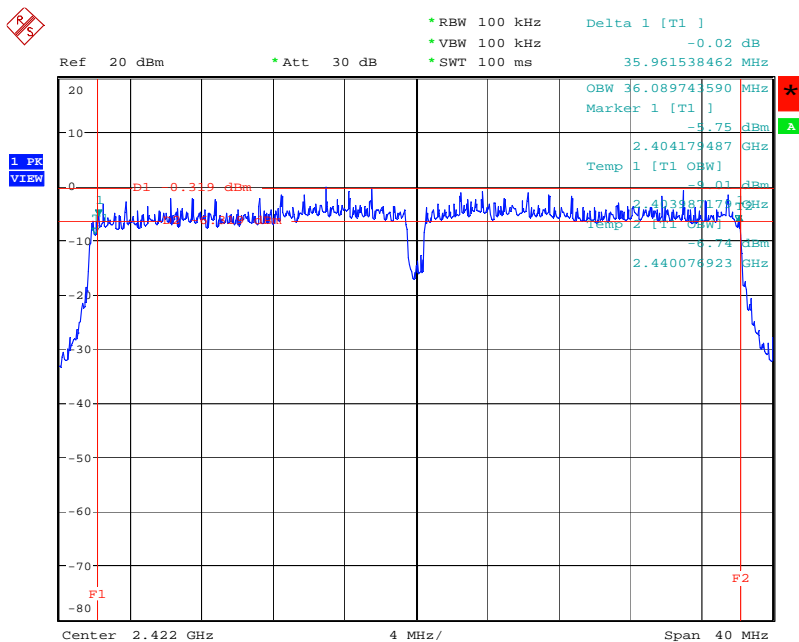

Date: 23.MAY.2007 15:38:19

6 dB Bandwidth Plot on Configuration Draft n MCS8 40MHz Ant. C / 2437 MHz

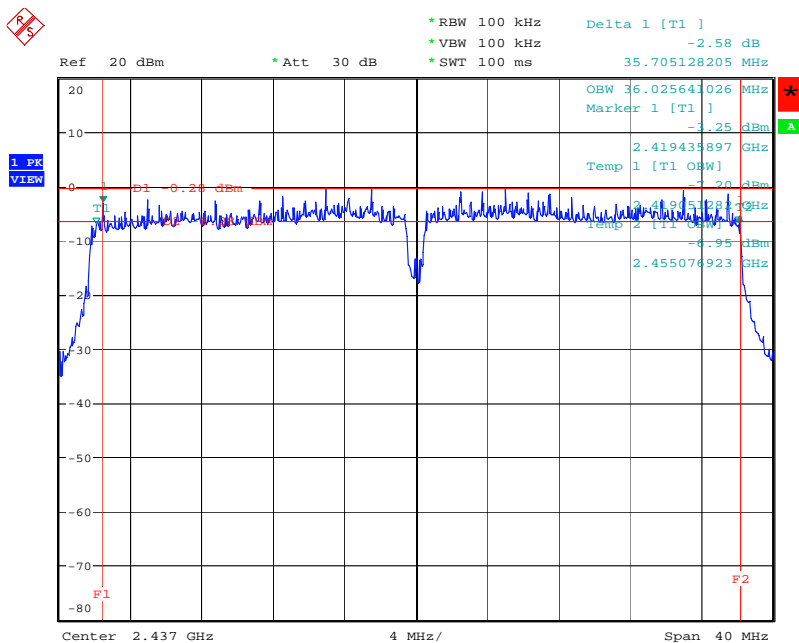

Date: 23.MAY.2007 15:37:03

6 dB Bandwidth Plot on Configuration Draft n MCS0 40MHz Ant. C / 2452 MHz

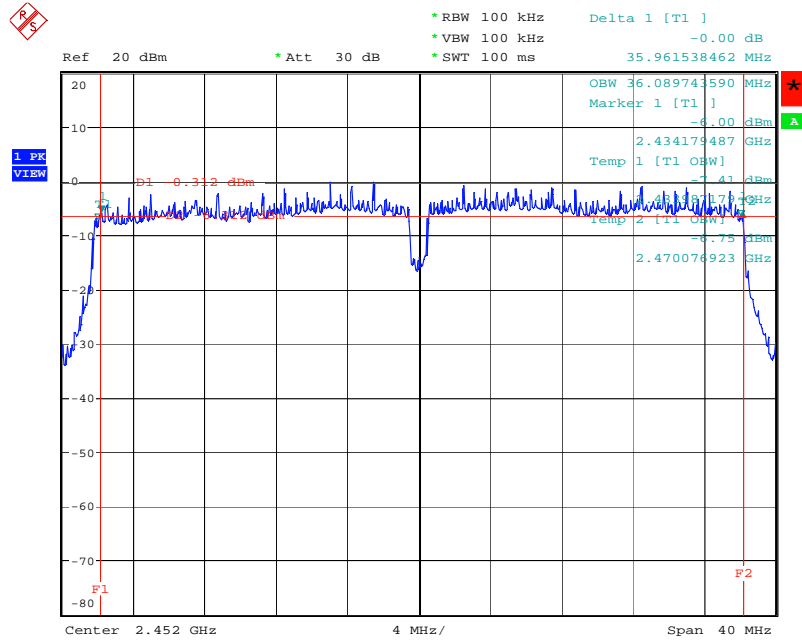

Date: 23.MAY.2007 15:35:37

6 dB Bandwidth Plot on Configuration Draft n MCS8 40MHz Ant. B + Ant. C / 2422 MHz

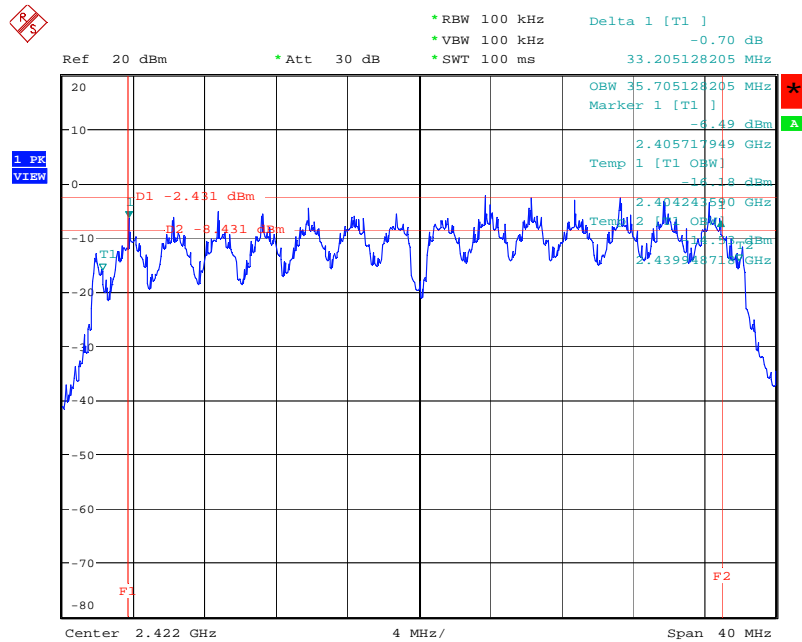

Date: 23.MAY.2007 16:45:28

6 dB Bandwidth Plot on Configuration Drafft n MCS8 40MHz Ant. B + Ant. C / 2437 MHz

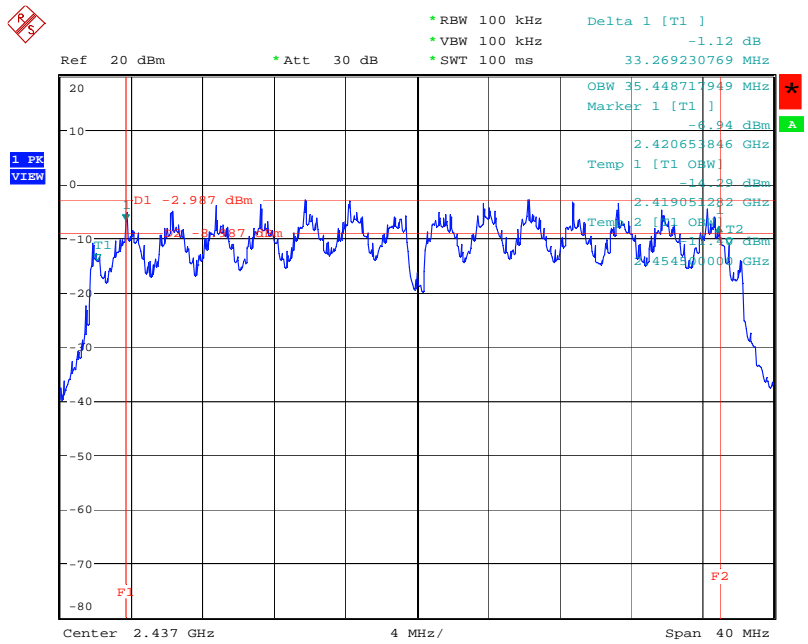

Date: 23.MAY.2007 16:44:05

6 dB Bandwidth Plot on Configuration Drafft n MCS8 40MHz Ant. B + Ant. C / 2452 MHz

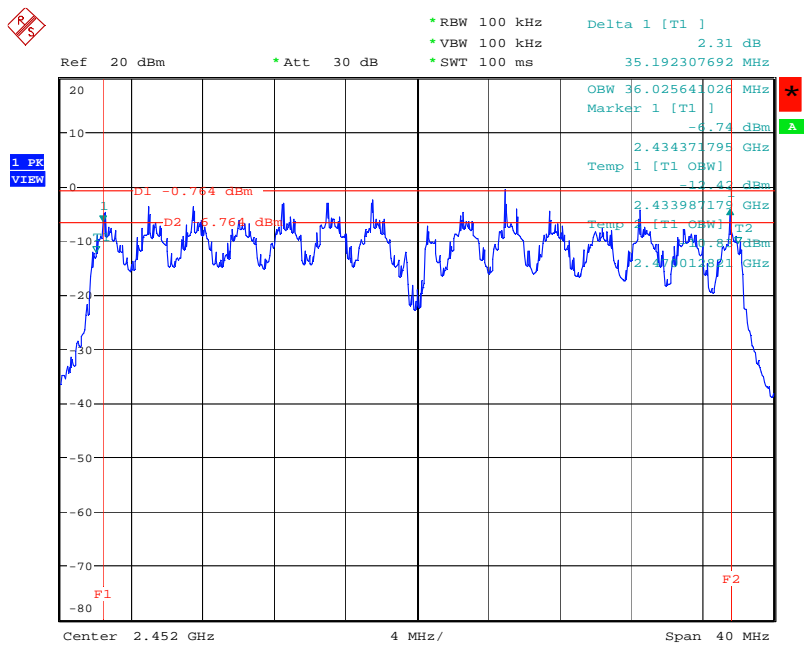

Date: 23.MAY.2007 16:42:41

4.5. Radiated Emissions Measurement

4.5.1. Limit

20dBc in any 100 kHz bandwidth outside the operating frequency band. In case the emission fall within the restricted band specified on 15.205(a), then the 15.209(a) limit in the table below has to be followed.

Frequencies (MHz)	Field Strength (micorvolts/meter)	Measurement Distance (meters)
0.009~0.490	2400/F(KHz)	300
0.490~1.705	24000/F(KHz)	30
1.705~30.0	30	30
30~88	100	3
88~216	150	3
216~960	200	3
Above 960	500	3

4.5.2. Measuring Instruments and Setting

Please refer to section 5 of equipments list in this report. The following table is the setting of spectrum analyzer and receiver.

Spectrum Parameter	Setting
Attenuation	Auto
Start Frequency	1000 MHz
Stop Frequency	10th carrier harmonic
RB / VB (Emission in restricted band)	1MHz / 1MHz for Peak, 1 MHz / 10Hz for Average
RB / VB (Emission in non-restricted band)	1000KHz / 1000KHz for peak

Receiver Parameter	Setting
Attenuation	Auto
Start ~ Stop Frequency	9kHz~150kHz / RB 200Hz for QP
Start ~ Stop Frequency	150kHz~30MHz / RB 9kHz for QP
Start ~ Stop Frequency	30MHz~1000MHz / RB 120kHz for QP

4.5.3. Test Procedures

1. Configure the EUT according to ANSI C63.4. The EUT was placed on the top of the turntable 0.8 meter above ground. The phase center of the receiving antenna mounted on the top of a height-variable antenna tower was placed 3 meters far away from the turntable.
2. Power on the EUT and all the supporting units. The turntable was rotated by 360 degrees to determine the position of the highest radiation.
3. The height of the broadband receiving antenna was varied between one meter and four meters above ground to find the maximum emissions field strength of both horizontal and vertical polarization.
4. For each suspected emissions, the antenna tower was scan (from 1 m to 4 m) and then the turntable was rotated (from 0 degree to 360 degrees) to find the maximum reading.
5. Set the test-receiver system to Peak or CISPR quasi-peak Detect Function with specified bandwidth under Maximum Hold Mode.
6. For emissions above 1GHz, use 1MHz VBW and RBW for peak reading. Then 1MHz RBW and 10Hz VBW for average reading in spectrum analyzer.
7. When the radiated emissions limits are expressed in terms of the average value of the emissions, and pulsed operation is employed, the measurement field strength shall be determined by averaging over one complete pulse train, including blanking intervals, as long as the pulse train does not exceed 0.1 seconds. As an alternative (provided the transmitter operates for longer than 0.1 seconds) or in cases where the pulse train exceeds 0.1 seconds, the measured field strength shall be determined from the average absolute voltage during a 0.1 second interval during which the field strength is at its maximum value.
8. If the emissions level of the EUT in peak mode was 3 dB lower than the average limit specified, then testing will be stopped and peak values of EUT will be reported, otherwise, the emissions which do not have 3 dB margin will be repeated one by one using the quasi-peak method for below 1GHz.
9. For testing above 1GHz, the emissions level of the EUT in peak mode was lower than average limit (that means the emissions level in peak mode also complies with the limit in average mode), then testing will be stopped and peak values of EUT will be reported, otherwise, the emissions will be measured in average mode again and reported.
10. In case the emission is lower than 30MHz, loop antenna has to be used for measurement and the recorded data should be QP measured by receiver. High – Low scan is not required in this case.

4.5.4. Test Setup Layout

For radiated emissions below 30MHz

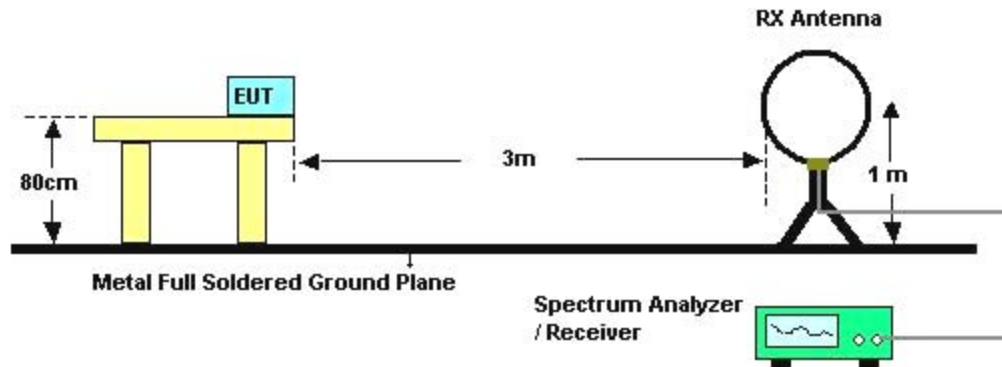

For radiated emissions above 30MHz

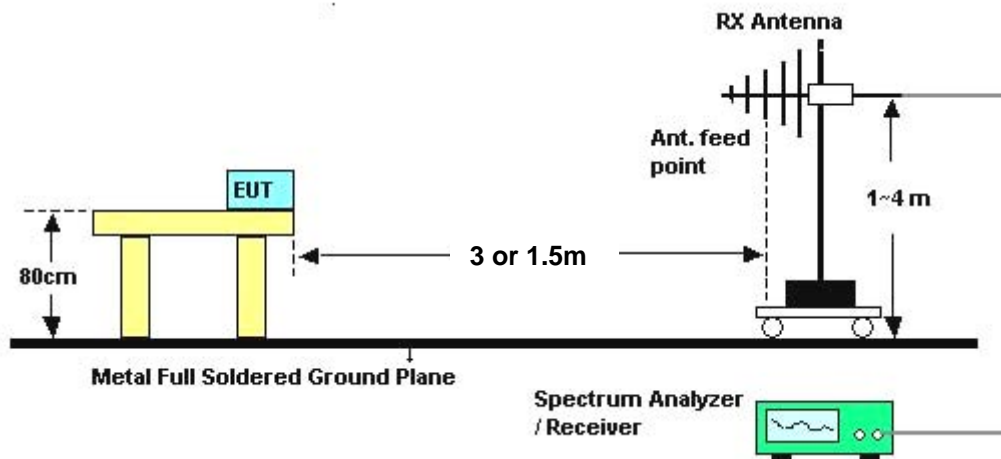

Above 10 GHz shall be extrapolated to the specified distance using an extrapolation factor of 20 dB/decade from 3m to 1.5m.

Distance extrapolation factor = $20 \log (\text{specific distance [3m]} / \text{test distance [1.5m]})$ (dB);

Limit line = specific limits (dBuV) + distance extrapolation factor [6 dB].

4.5.5. Test Deviation

There is no deviation with the original standard.

4.5.6. EUT Operation during Test

The EUT was programmed to be in continuously transmitting mode.

4.5.7. Results of Radiated Emissions (9kHz~30MHz)

Temperature	23°C	Humidity	62%
Test Engineer	Jacky Ho	Configurations	Draft n Ch 6 40MHz Ant. B + Ant. C

Freq. (MHz)	Level (dBuV)	Over Limit (dB)	Limit Line (dBuV)	Remark
-	-	-	-	See Note

Note:

The amplitude of spurious emissions which are attenuated by more than 20 dB below the permissible value has no need to be reported.

Distance extrapolation factor = $40 \log(\text{specific distance} / \text{test distance})$ (dB);

Limit line = specific limits (dBuV) + distance extrapolation factor.

4.5.8. Results of Radiated Emissions (30MHz~1GHz)

Temperature	23°C	Humidity	62%
Test Engineer	Jacky Ho	Configurations	Draft n Ch 6 Ant. B + Ant. C

Horizontal

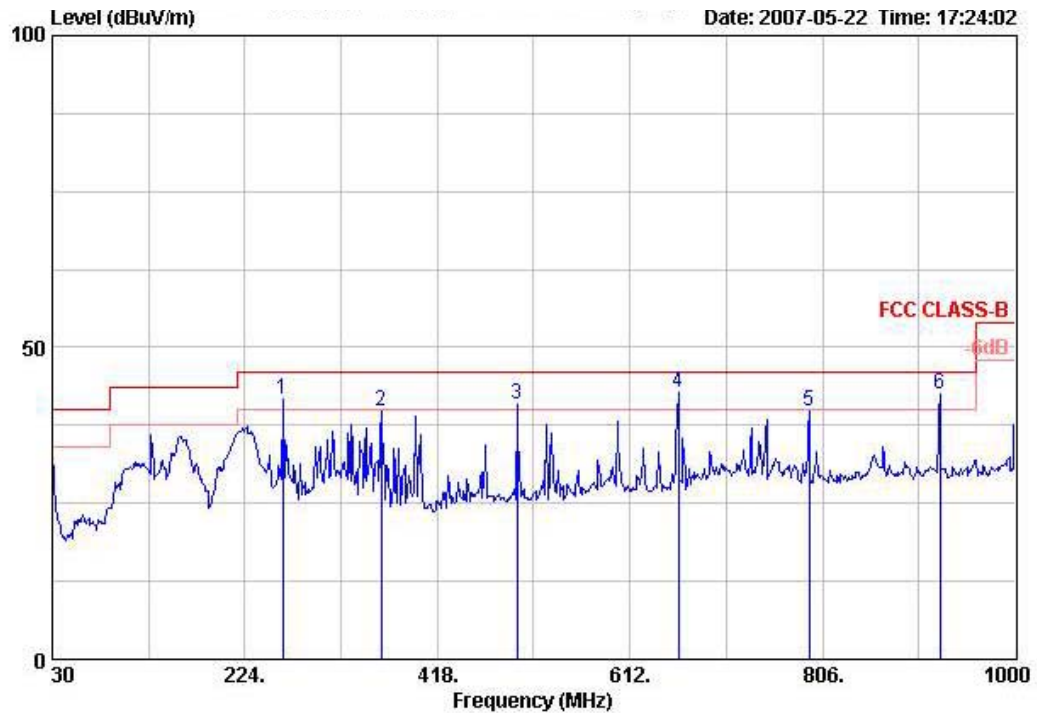

	Read Freq	Read Level	Limit Level	Limit Line	OverLimit	Antenna Factor	Preamp Factor	Cable Loss	Remark	Ant Pos	Table Pos	Pol/Phase
	MHz	dBuV	dBuV/m	dBuV/m	dB	dB/m	dB	dB		cm	deg	
1 !	261.830	56.55	41.59	46.00	-4.41	13.88	31.34	2.50	Peak	---	---	HORIZONTAL
2	361.740	52.79	39.75	46.00	-6.25	15.68	31.19	2.47	Peak	---	---	HORIZONTAL
3 !	498.510	50.72	40.93	46.00	-5.07	17.87	30.94	3.28	Peak	---	---	HORIZONTAL
4 *	660.500	50.06	42.88	46.00	-3.12	19.64	30.35	3.52	Peak	---	---	HORIZONTAL
5	792.420	45.52	39.78	46.00	-6.22	20.64	30.19	3.82	Peak	---	---	HORIZONTAL
6 !	924.340	46.23	42.37	46.00	-3.63	21.75	29.61	4.00	Peak	---	---	HORIZONTAL

Vertical

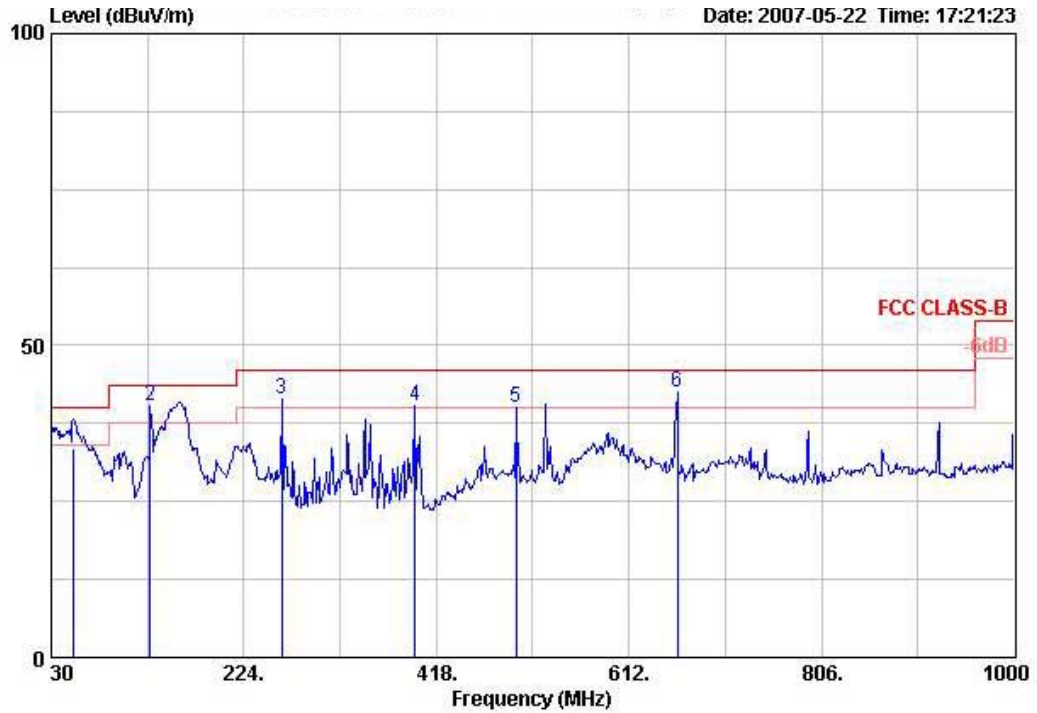

	Read Freq	Read Level	Limit Level	Limit Line	Over Limit	Antenna Factor	Preamp Factor	Cable Loss	Remark	Ant Pos	Table Pos	Pol/Phase
	MHz	dBuV	dBuV/m	dBuV/m	dB	dB/m	dB	dB		cm	deg	
1	52.120	55.40	33.46	40.00	-6.54	8.68	31.78	1.17	QP	100	35	VERTICAL
2 *	129.910	57.79	40.33	43.50	-3.17	12.50	31.67	1.70	Peak	---	---	VERTICAL
3 !	261.830	56.41	41.45	46.00	-4.55	13.88	31.34	2.50	Peak	---	---	VERTICAL
4 !	396.660	52.30	40.46	46.00	-5.54	16.53	31.04	2.68	Peak	---	---	VERTICAL
5 !	498.510	49.91	40.13	46.00	-5.87	17.87	30.94	3.28	Peak	---	---	VERTICAL
6 !	660.500	49.63	42.45	46.00	-3.55	19.64	30.35	3.52	Peak	---	---	VERTICAL

Note:

The amplitude of spurious emissions which are attenuated by more than 20 dB below the permissible value has no need to be reported.

Emission level (dBUV/m) = 20 log Emission level (uV/m).

Corrected Reading: Antenna Factor + Cable Loss + Read Level - Preamp Factor = Level.

4.5.9. Results for Radiated Emissions (1GHz~10th Harmonic)

Temperature	23°C	Humidity	62%
Test Engineer	Jacky Ho	Configurations	Draft n MCS8 20MHz Ch 1 Ant. B + Ant. C

Horizontal

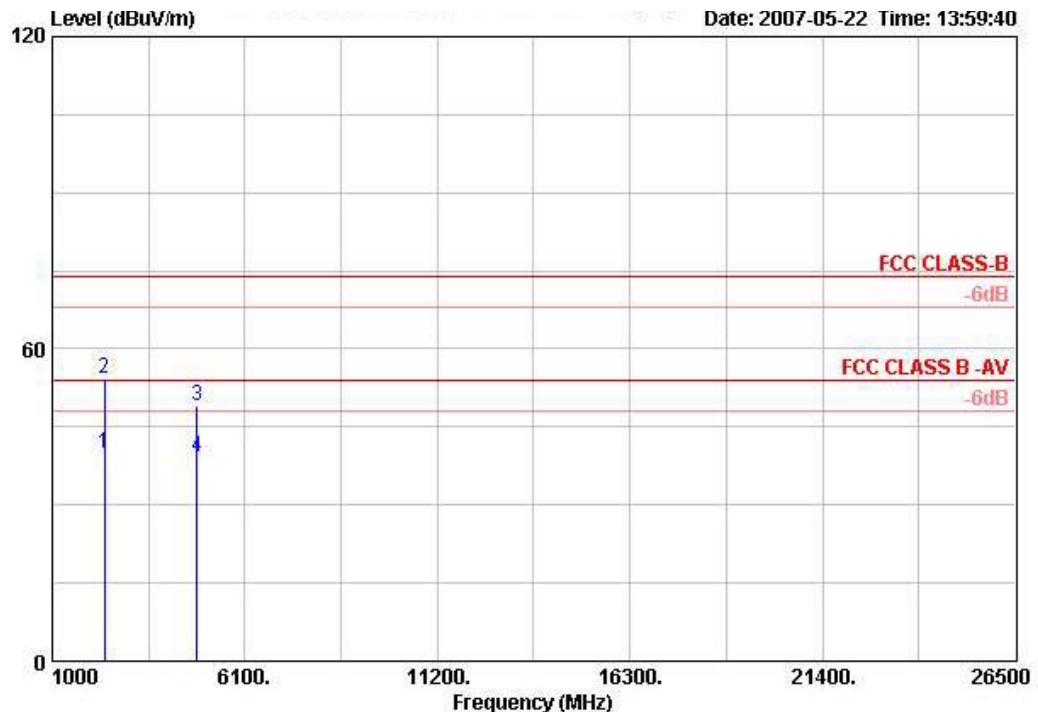

	Read	Limit	Over	Antenna	Preamp	Cable		Ant	Table			
	Level	Line	Limit	Factor	Factor	Loss	Remark	Pos	Pos			
	dBuV	dBuV/m	dBuV/m	dB	dB/m	dB		cm	deg			
1	2375.660	44.00	39.79	54.00	-14.21	28.13	35.10	2.76	AVERAGE	100	188	HORIZONTAL
2	2381.220	58.58	54.38	74.00	-19.62	28.13	35.10	2.76	PEAK	100	188	HORIZONTAL
3	4823.480	46.83	49.02	74.00	-24.98	33.06	35.16	4.30	PEAK	112	308	HORIZONTAL
4	4823.860	37.15	39.34	54.00	-14.66	33.06	35.16	4.30	AVERAGE	112	308	HORIZONTAL

Vertical

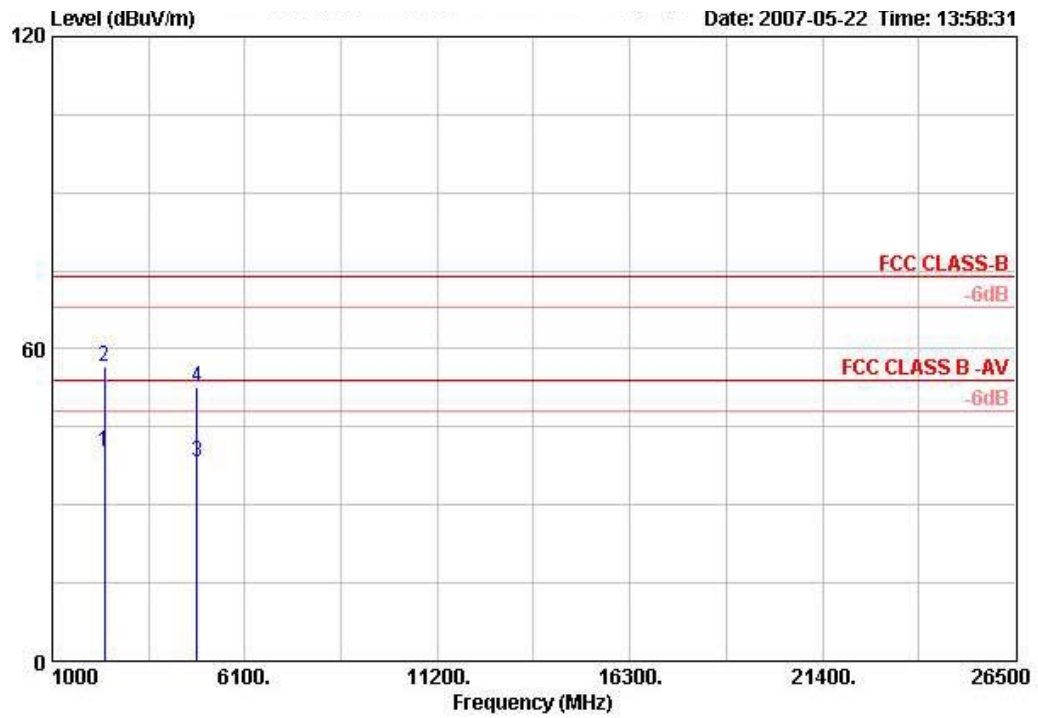

	Read Freq	Read Level	Limit Level	Limit Line	OverLimit	Antenna Factor	Preamp Factor	Cable Loss	Remark	Ant Pos	Table Pos	Pol/Phase
	MHz	dBuV	dBuV/m	dBuV/m	dB	dB/m	dB	dB		cm	deg	
1	2374.860	44.44	40.24	54.00	-13.76	28.13	35.10	2.76	AVERAGE	152	289	VERTICAL
2	2377.880	60.83	56.63	74.00	-17.37	28.13	35.10	2.76	PEAK	152	289	VERTICAL
3	4823.940	36.07	38.26	54.00	-15.74	33.06	35.16	4.30	AVERAGE	100	174	VERTICAL
4	4824.020	50.55	52.74	74.00	-21.26	33.06	35.16	4.30	PEAK	100	174	VERTICAL

Temperature	23°C	Humidity	62%
Test Engineer	Jacky Ho	Configurations	Draft n MCS8 20MHz Ch 6 Ant. B + Ant. C

Horizontal

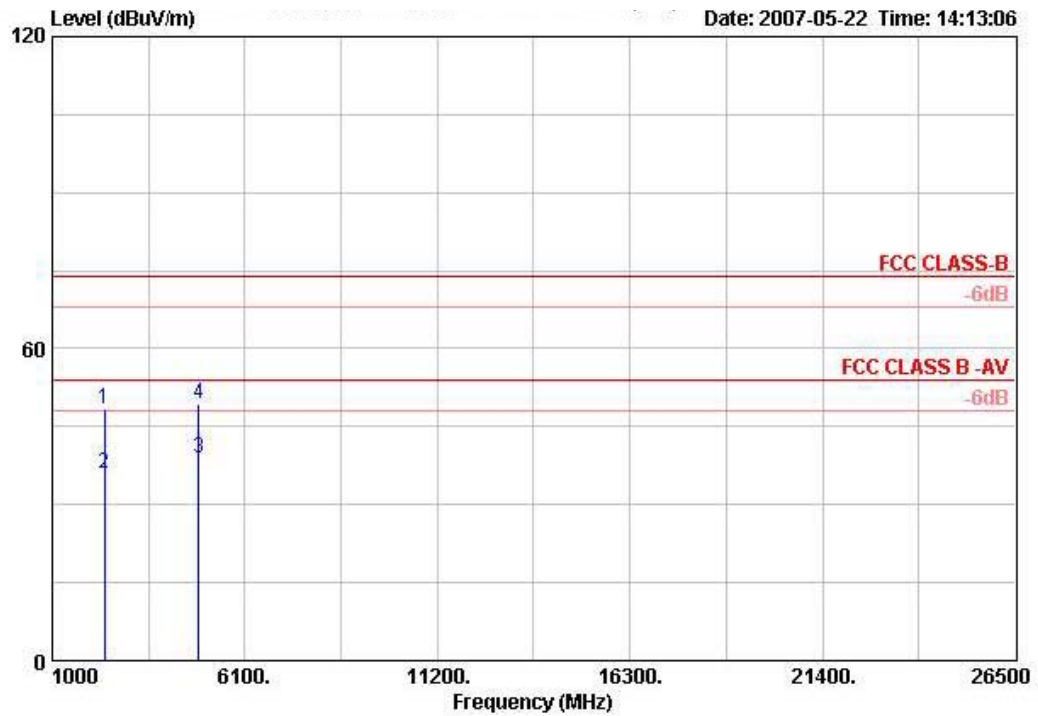

	Read Freq	Read Level	Read Level	Limit Line	OverLimit	Antenna Factor	Preamp Factor	Cable Loss	Remark	Ant Pos	Table Pos	Pol/Phase
	MHz	dBuV	dBuV/m	dBuV/m	dB	dB/m	dB	dB		cm	deg	
1	2374.500	52.69	48.48	74.00	-25.52	28.13	35.10	2.76	PEAK	100	190	HORIZONTAL
2	2377.060	40.18	35.98	54.00	-18.02	28.13	35.10	2.76	AVERAGE	100	190	HORIZONTAL
3	4873.980	36.74	39.05	54.00	-14.95	33.16	35.15	4.30	AVERAGE	118	300	HORIZONTAL
4	4873.980	47.07	49.38	74.00	-24.62	33.16	35.15	4.30	PEAK	118	300	HORIZONTAL

Vertical

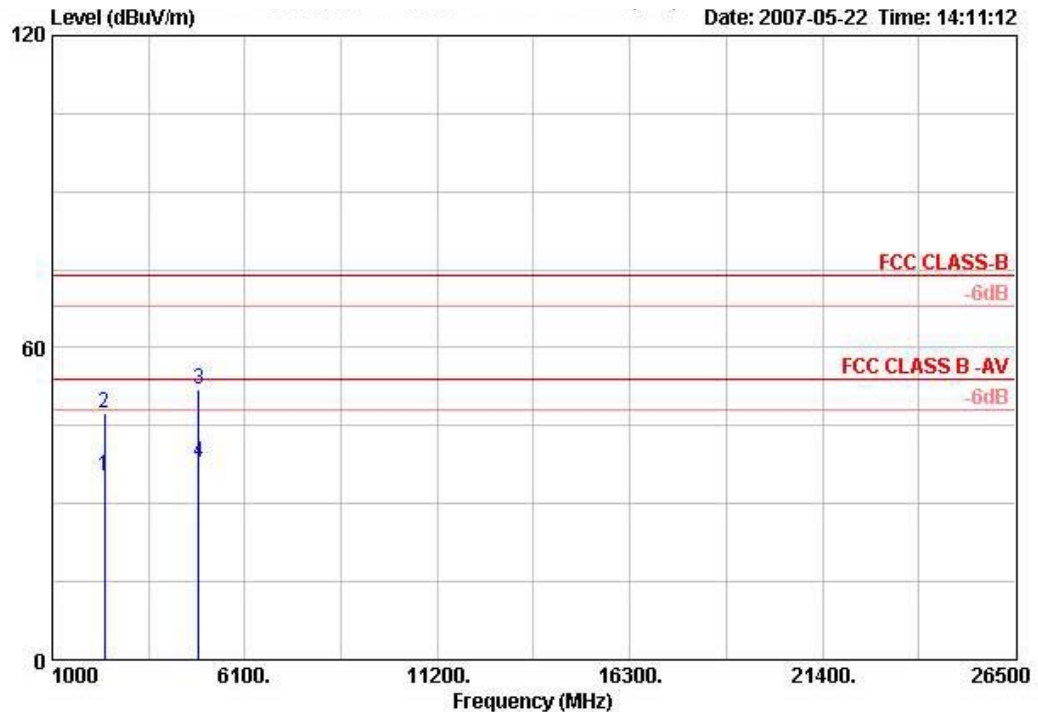

	Freq	Read Level	Limit Level	Limit Line	Over Limit	Antenna Factor	Preamp Factor	Cable Loss	Remark	Ant Pos	Table Pos	Pol/Phase
	MHz	dBuV	dBuV/m	dBuV/m	dB	dB/m	dB	dB		cm	deg	
1	2377.040	39.44	35.23	54.00	-18.77	28.13	35.10	2.76	AVERAGE	100	183	VERTICAL
2	2377.360	51.69	47.49	74.00	-26.51	28.13	35.10	2.76	PEAK	100	183	VERTICAL
3	4872.840	49.66	51.96	74.00	-22.04	33.16	35.15	4.30	PEAK	100	234	VERTICAL
4	4873.720	35.72	38.03	54.00	-15.97	33.16	35.15	4.30	AVERAGE	100	234	VERTICAL

Temperature	23°C	Humidity	62%
Test Engineer	Jacky Ho	Configurations	Draft n MCS8 20MHz Ch11 Ant. B + Ant. C

Horizontal

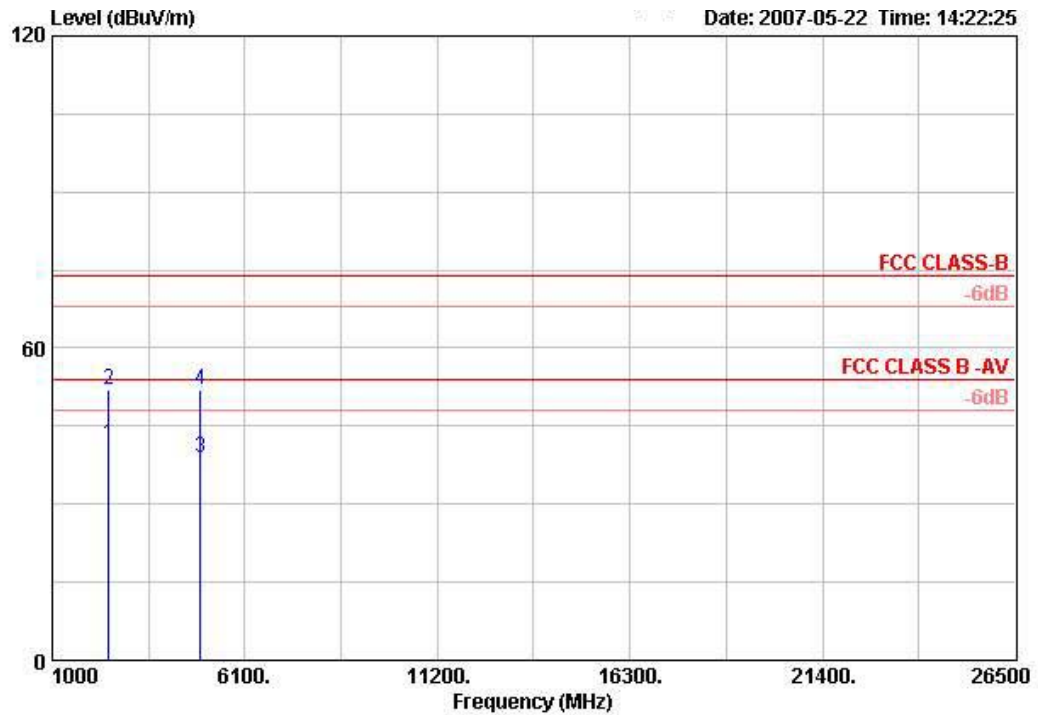

	Read Freq	Read Level	Read Level	Limit Line	Over Limit	Antenna Factor	Preamp Factor	Cable Loss	Remark	Ant Pos	Table Pos	Pol/Phase
	MHz	dBuV	dBuV/m	dBuV/m	dB	dB/m	dB	dB		cm	deg	
1	2499.800	45.58	41.65	54.00	-12.35	28.40	35.18	2.84	AVERAGE	135	168	HORIZONTAL
2	2499.800	55.89	51.96	74.00	-22.04	28.40	35.18	2.84	PEAK	135	168	HORIZONTAL
3	4924.100	36.47	38.89	54.00	-15.11	33.26	35.14	4.30	AVERAGE	100	246	HORIZONTAL
4	4924.500	49.49	51.91	74.00	-22.09	33.26	35.14	4.30	PEAK	100	246	HORIZONTAL

Vertical

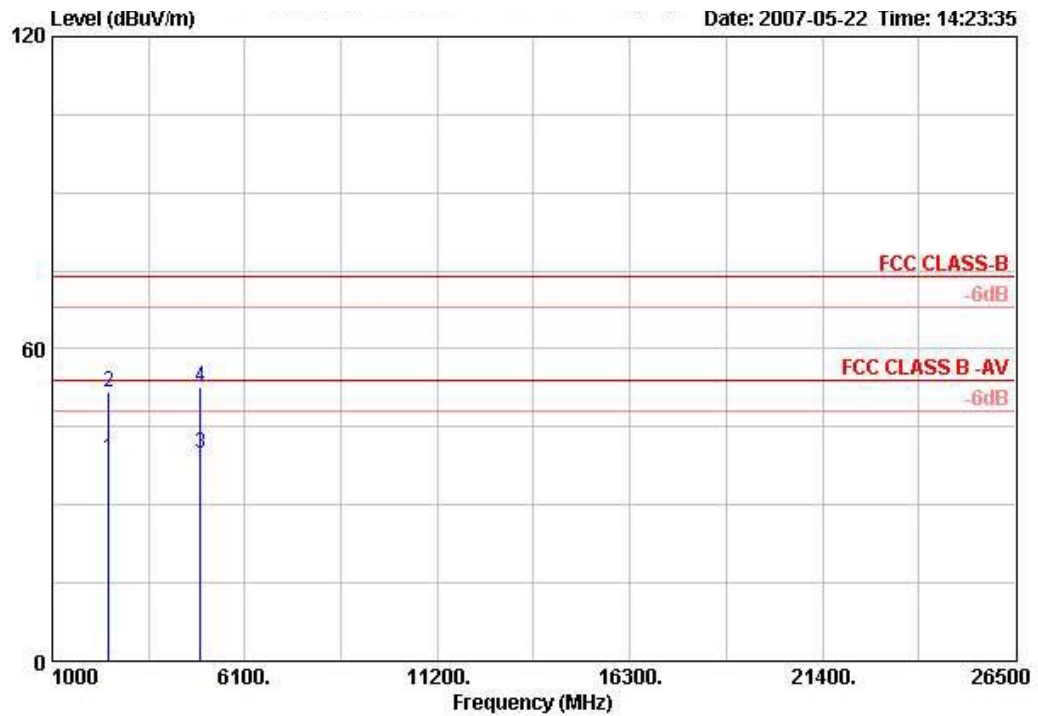

	Read Freq	Read Level	Read Level	Limit Line	OverLimit	Antenna Factor	Preamp Factor	Cable Loss	Remark	Ant Pos	Table Pos	Pol/Phase
	MHz	dBuV	dBuV/m	dBuV/m	dB	dB/m	dB	dB		cm	deg	
1	2499.800	42.96	39.02	54.00	-14.98	28.40	35.18	2.84	AVERAGE	100	218	VERTICAL
2	2499.800	55.55	51.61	74.00	-22.39	28.40	35.18	2.84	PEAK	100	218	VERTICAL
3	4923.960	37.61	40.03	54.00	-13.97	33.26	35.14	4.30	AVERAGE	100	200	VERTICAL
4	4928.500	50.14	52.56	74.00	-21.44	33.26	35.14	4.30	PEAK	100	200	VERTICAL

Temperature	23°C	Humidity	62%
Test Engineer	Jacky Ho	Configurations	Draft n MCS8 40MHz Ch 3 Ant. B + Ant. C

Horizontal

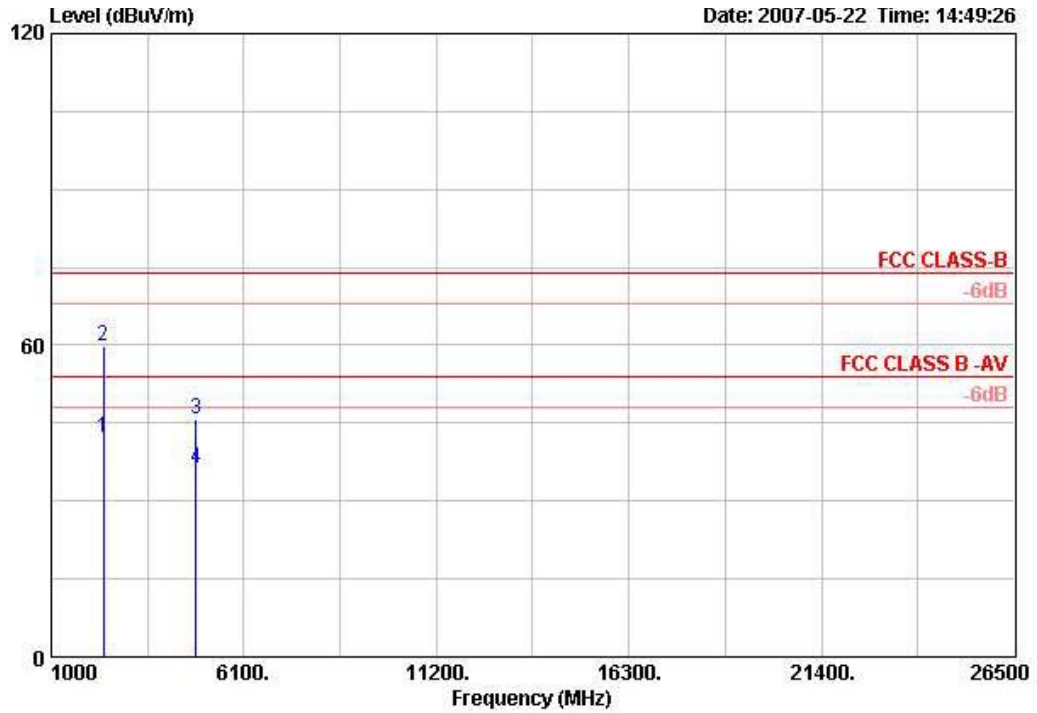

	Freq	Read Level	Level	Limit Line	Over Limit	Antenna Factor	Preamp Factor	Cable Loss	Remark	Ant Pos	Table Pos	Pol/Phase
	MHz	dBuV	dBuV/m	dBuV/m	dB	dB/m	dB	dB		cm	deg	
1	2378.580	46.38	42.18	54.00	-11.82	28.13	35.10	2.76	AVERAGE	100	191	HORIZONTAL
2	2378.780	63.97	59.77	74.00	-14.23	28.13	35.10	2.76	PEAK	100	191	HORIZONTAL
3	4843.960	43.56	45.80	74.00	-28.20	33.09	35.16	4.30	PEAK	100	244	HORIZONTAL
4	4843.980	34.00	36.23	54.00	-17.77	33.09	35.16	4.30	AVERAGE	100	244	HORIZONTAL

Vertical

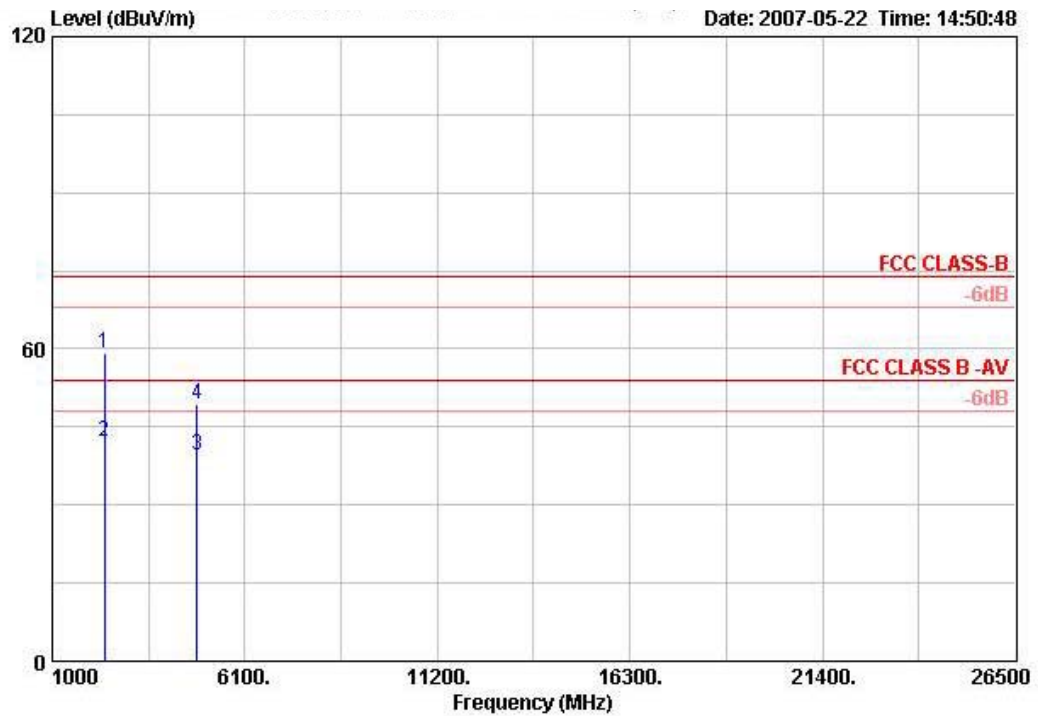

	Read Freq	Read Level	Limit Level	Limit Line	Over Limit	Antenna Factor	Preamp Factor	Cable Loss	Table Pos	Table Pos	Table Pol/Phase
	MHz	dBuV	dBuV/m	dBuV/m	dB	dB/m	dB	dB	cm	deg	
1	2376.780	63.47	59.27	74.00	-14.73	28.13	35.10	2.76	102	36	VERTICAL
2	2378.960	46.32	42.11	54.00	-11.89	28.13	35.10	2.76	102	36	VERTICAL
3	4843.960	37.46	39.69	54.00	-14.31	33.09	35.16	4.30	100	184	VERTICAL
4	4844.140	47.21	49.44	74.00	-24.56	33.09	35.16	4.30	100	184	VERTICAL

Temperature	23°C	Humidity	62%
Test Engineer	Jacky Ho	Configurations	Draft n MCS8 40MHz Ch 6 Ant. B + Ant. C

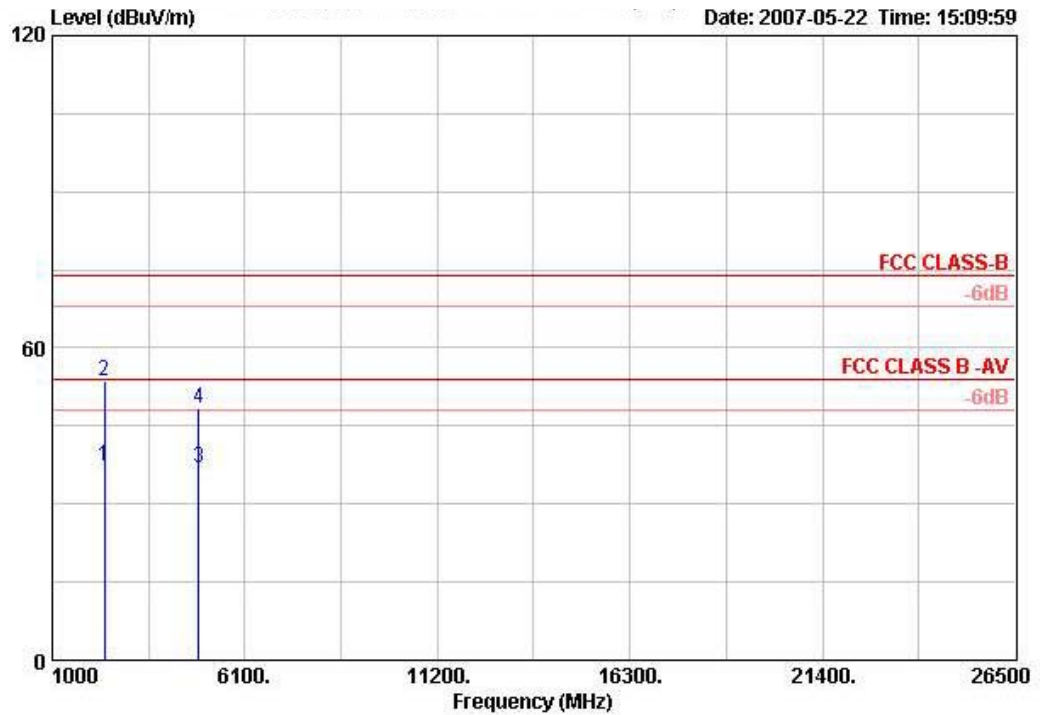
Horizontal

	Read Freq	Read Level	Read Level	Limit Line	Over Limit	Antenna Factor	Preamp Factor	Cable Loss	Remark	Ant Pos	Table Pos	Pol/Phase
	MHz	dBuV	dBuV/m	dBuV/m	dB	dB/m	dB	dB		cm	deg	
1	2379.060	41.35	37.15	54.00	-16.85	28.13	35.10	2.76	AVERAGE	100	190	HORIZONTAL
2	2379.240	57.96	53.75	74.00	-20.25	28.13	35.10	2.76	PEAK	100	190	HORIZONTAL
3	4874.000	34.54	36.84	54.00	-17.16	33.16	35.15	4.30	AVERAGE	128	239	HORIZONTAL
4	4874.460	46.02	48.33	74.00	-25.67	33.16	35.15	4.30	PEAK	128	239	HORIZONTAL

Vertical

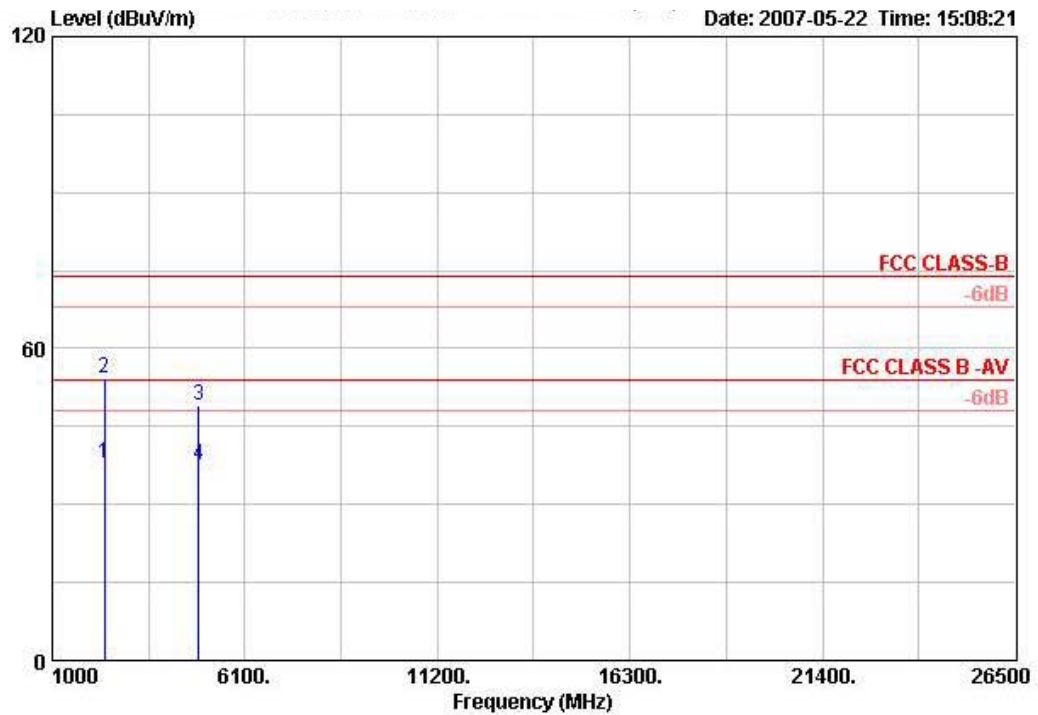

	Read	Limit	OverAntenna	Preamp	Cable	Ant	Table				
	Freq	Level	Line	Limit	Factor	Factor	Loss	Remark	Pos	Pos	Pol/Phase
	MHz	dBuV	dBuV/m	dBuV/m	dB	dB/m	dB		cm	deg	
1	2377.580	42.28	38.08	54.00	-15.92	28.13	35.10	2.76 AVERAGE	133	190	VERTICAL
2	2380.250	58.57	54.37	74.00	-19.63	28.13	35.10	2.76 PEAK	133	190	VERTICAL
3	4873.420	46.73	49.03	74.00	-24.97	33.16	35.15	4.30 PEAK	100	208	VERTICAL
4	4873.900	35.33	37.64	54.00	-16.36	33.16	35.15	4.30 AVERAGE	100	208	VERTICAL

Temperature	23°C	Humidity	62%
Test Engineer	Jacky Ho	Configurations	Draft n MCS8 40MHz Ch 9 Ant. B + Ant. C

Horizontal

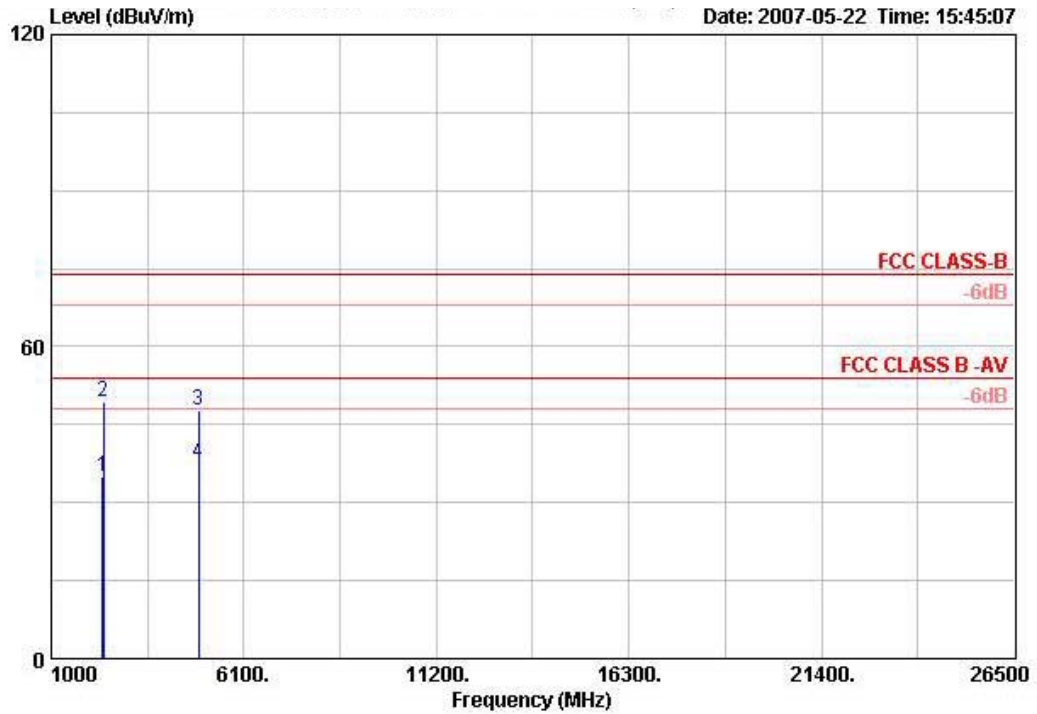

	Read Freq	Read Level	Read Level	Limit Line	OverLimit	Antenna Factor	Preamp Factor	Cable Loss	Remark	Ant Pos	Table Pos	Pol/Phase
	MHz	dBuV	dBuV/m	dBuV/m	dB	dB/m	dB	dB		cm	deg	
1	2371.000	39.13	34.93	54.00	-19.07	28.13	35.10	2.76	AVERAGE	161	171	HORIZONTAL
2	2374.780	53.69	49.49	74.00	-24.51	28.13	35.10	2.76	PEAK	161	171	HORIZONTAL
3	4903.880	45.46	47.84	74.00	-26.16	33.23	35.15	4.30	PEAK	128	28	HORIZONTAL
4	4903.940	35.18	37.56	54.00	-16.44	33.23	35.15	4.30	AVERAGE	128	28	HORIZONTAL

Vertical

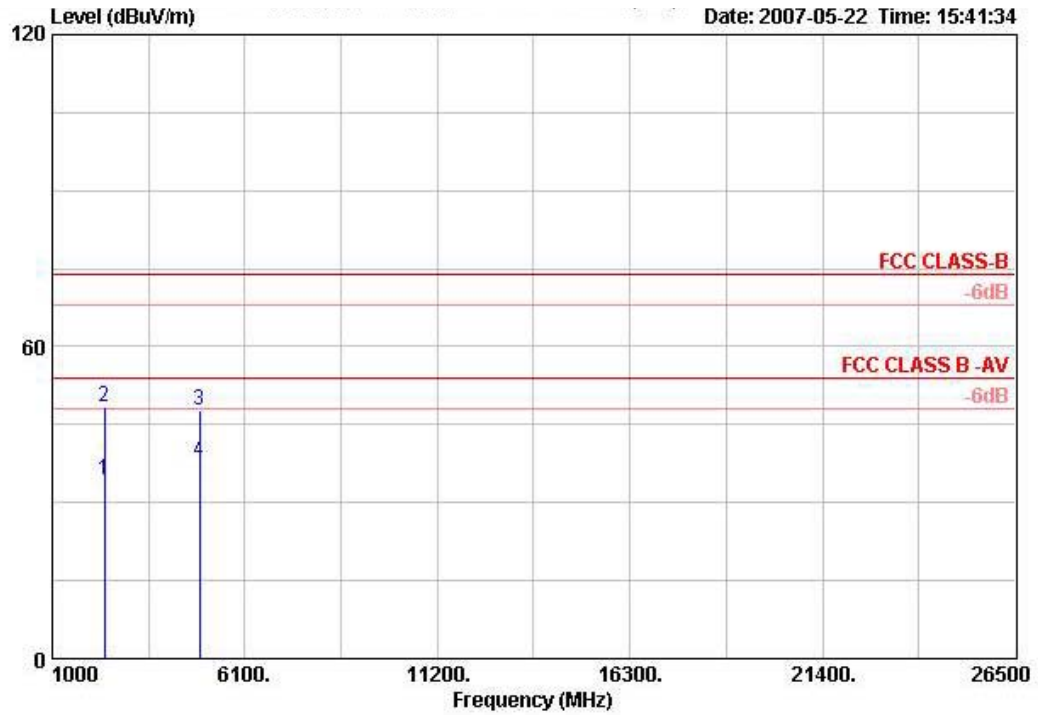

	Freq	Read Level	Limit Level	Limit Line	OverLimit	Antenna Factor	Preamp Factor	Cable Loss	Remark	Ant Pos	Table Pos	Pol/Phase
	MHz	dBuV	dBuV/m	dBuV/m	dB	dB/m	dB	dB		cm	deg	
1	2375.780	38.39	34.19	54.00	-19.81	28.13	35.10	2.76	AVERAGE	131	191	VERTICAL
2	2378.960	52.50	48.30	74.00	-25.70	28.13	35.10	2.76	PEAK	131	191	VERTICAL
3	4903.900	45.39	47.77	74.00	-26.23	33.23	35.15	4.30	PEAK	97	42	VERTICAL
4	4903.980	35.57	37.95	54.00	-16.05	33.23	35.15	4.30	AVERAGE	97	42	VERTICAL

Note:

The amplitude of spurious emissions which are attenuated by more than 20 dB below the permissible value has no need to be reported.

Emission level (dBUV/m) = 20 log Emission level (uV/m).

Corrected Reading: Antenna Factor + Cable Loss + Read Level - Preamp Factor = Level.

4.6. Band Edge Emissions Measurement

4.6.1. Limit

20dBc in any 100 kHz bandwidth outside the operating frequency band. In case the emission fall within the restricted band specified on 15.205(a), then the 15.209(a) limit in the table below has to be followed.

Frequencies (MHz)	Field Strength (micovolts/meter)	Measurement Distance (meters)
0.009~0.490	2400/F(KHz)	300
0.490~1.705	24000/F(KHz)	30
1.705~30.0	30	30
30~88	100	3
88~216	150	3
216~960	200	3
Above 960	500	3

4.6.2. Measuring Instruments and Setting

Please refer to section 5 of equipments list in this report. The following table is the setting of the spectrum analyzer.

Spectrum Parameter	Setting
Attenuation	Auto
Span Frequency	100 MHz
RB / VB (Emission in restricted band)	1 MHz / 1MHz for Peak, 1 MHz / 10Hz for Average
RB / VB (Emission in non-restricted band)	100 KHz /100 KHz for Peak

4.6.3. Test Procedures

1. The test procedure is the same as section 4.5.3, only the frequency range investigated is limited to 100MHz around bandedges.
2. In case the emission is fail due to the used RB/VB is too wide, marker-delta method of FCC Public Notice DA00-705 will be followed.

4.6.4. Test Setup Layout

This test setup layout is the same as that shown in section 4.5.4.

4.6.5. Test Deviation

There is no deviation with the original standard.

4.6.6. EUT Operation during Test

The EUT was programmed to be in continuously transmitting mode.

4.6.7. Test Result of Band Edge and Fundamental Emissions

Temperature	23°C	Humidity	62%
Test Engineer	Jacky Ho	Configurations	Draft n MCS8 20MHz Ch 1, 11 Ant. B + Ant. C

Channel 1

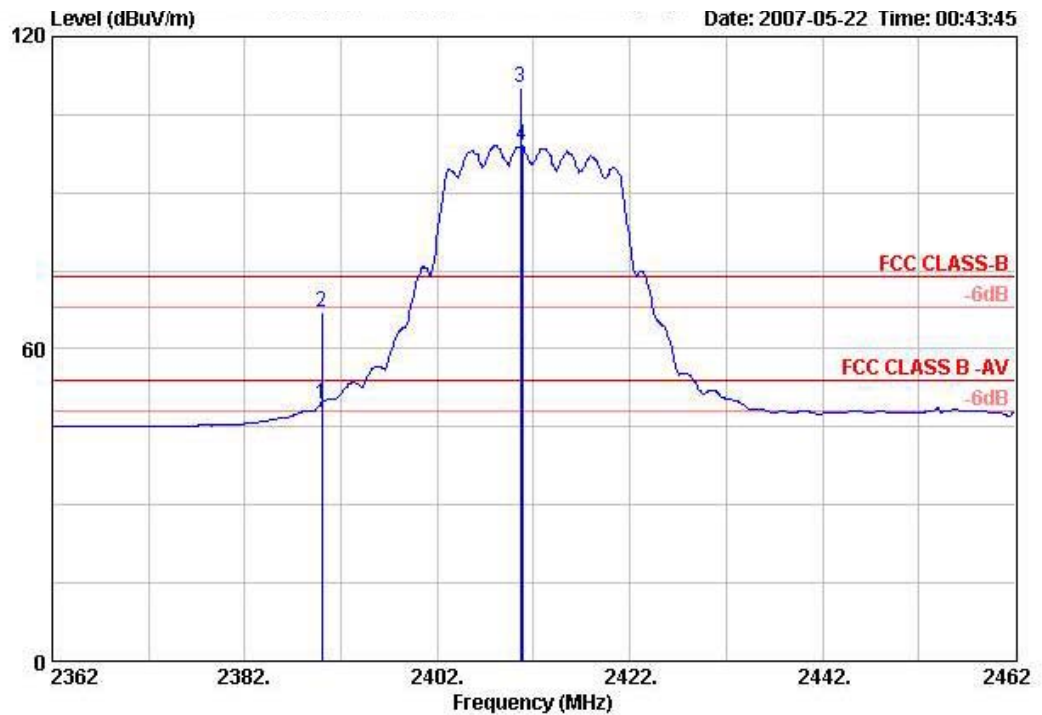

	Read Freq	Read Level	Read Level	Limit Line	Over Limit	Antenna Factor	Preamp Factor	Cable Loss	Remark	Ant Pos	Table Pos	Pol/Phase
	MHz	dBuV	dBuV/m	dBuV/m	dB	dB/m	dB	dB		cm	deg	
1 !	2390.000	18.60	49.53	54.00	-4.47	28.17	0.00	2.76	AVERAGE	100	193	VERTICAL
2	2390.000	36.12	67.05	74.00	-6.95	28.17	0.00	2.76	PEAK	100	193	VERTICAL
3 *	2410.600	79.17	110.17			28.21	0.00	2.79	PEAK	100	193	VERTICAL
4 *	2410.800	68.17	99.17			28.21	0.00	2.79	AVERAGE	100	193	VERTICAL

Item 3, 4 are the fundamental frequency at 2412 MHz

Channel 11

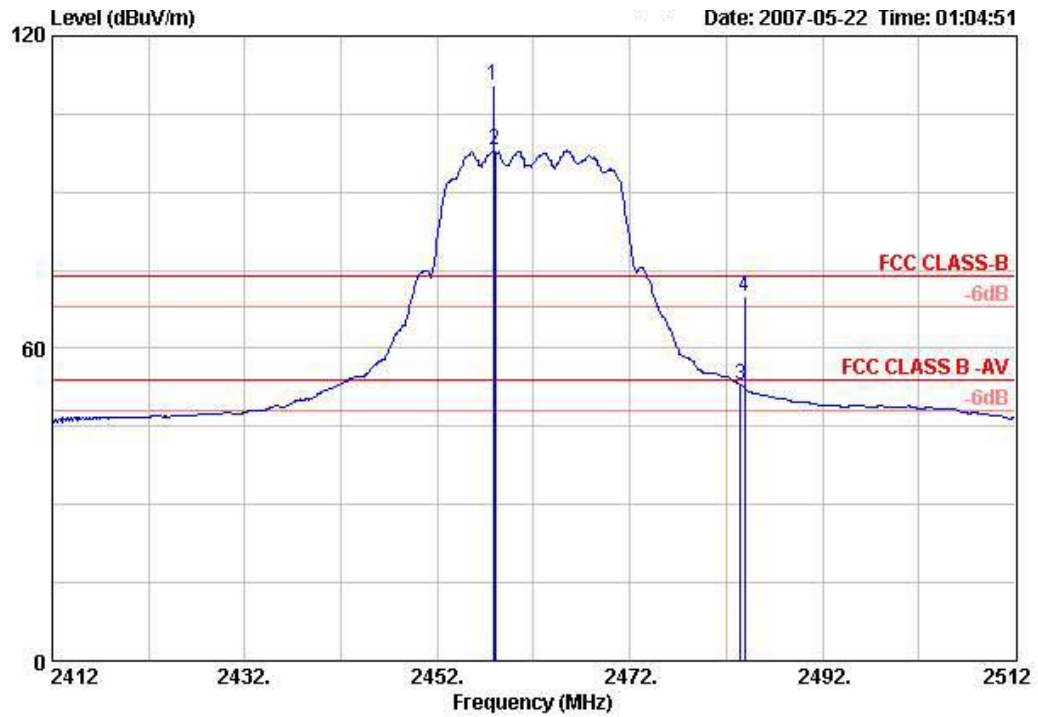

	Read Freq	Read Level	Limit Level	Limit Line	OverLimit	Antenna Factor	Preamp Factor	Cable Loss	Remark	Ant Pos	Table Pos	Pol/Phase
	MHz	dBuV	dBuV/m	dBuV/m	dB	dB/m	dB	dB		cm	deg	
1 *	2457.800	79.30	110.44			28.32	0.00	2.81	PEAK	122	186	VERTICAL
2 *	2458.000	66.80	97.94			28.32	0.00	2.81	AVERAGE	122	186	VERTICAL
3 *	2483.500	21.70	52.91	54.00	-1.09	28.36	0.00	2.84	AVERAGE	122	186	VERTICAL
4 !	2483.900	38.76	69.96	74.00	-4.04	28.36	0.00	2.84	PEAK	122	186	VERTICAL

Item 1, 2 are the fundamental frequency at 2462 MHz.

Temperature	23°C	Humidity	62%
Test Engineer	Jacky Ho	Configurations	Draft n MCS8 40MHz Ch 3, 9 Ant. B + Ant. C

Channel 3

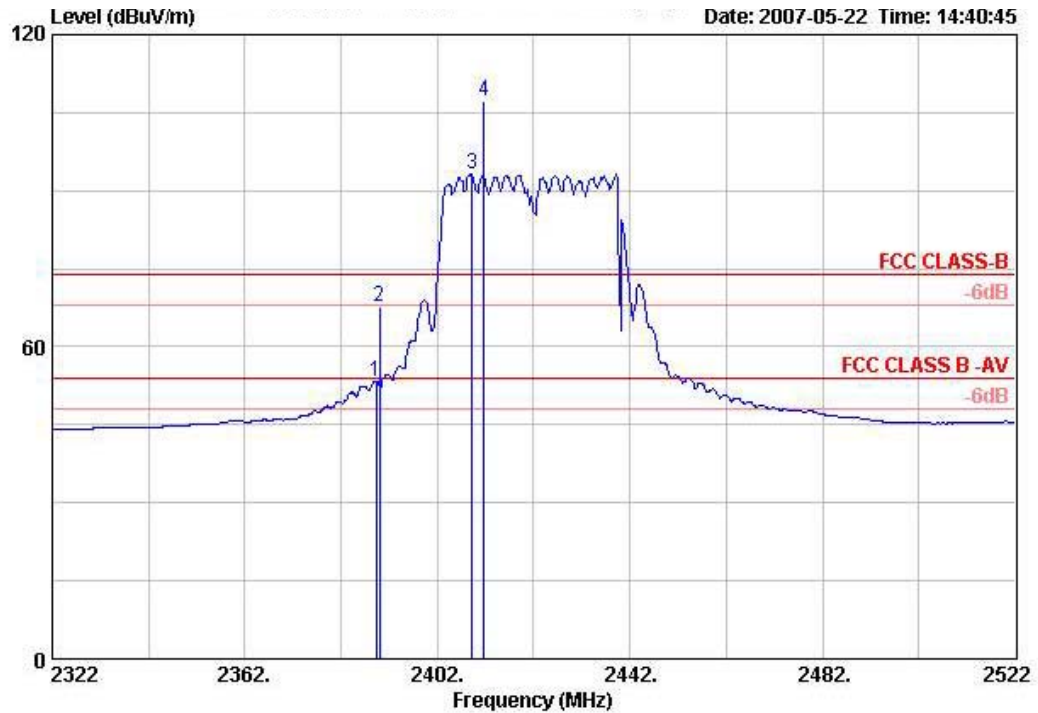

	Read Freq	Read Level	Read Level	Limit Line	Over Limit	Antenna Factor	Preamp Factor	Cable Loss	Remark	Ant Pos	Table Pos	Table Pol/Phase
	MHz	dBuV	dBuV/m	dBuV/m	dB	dB/m	dB	dB		cm	deg	
1 *	2389.200	22.40	53.33	54.00	-0.67	28.17	0.00	2.76	AVERAGE	102	191	VERTICAL
2	2390.000	36.65	67.59	74.00	-6.41	28.17	0.00	2.76	PEAK	102	191	VERTICAL
3 *	2409.200	62.25	93.25			28.21	0.00	2.79	AVERAGE	102	191	VERTICAL
4 *	2411.600	76.18	107.18			28.21	0.00	2.79	PEAK	102	191	VERTICAL

Item 3, 4 are the fundamental frequency at 2422 MHz.

Channel 9

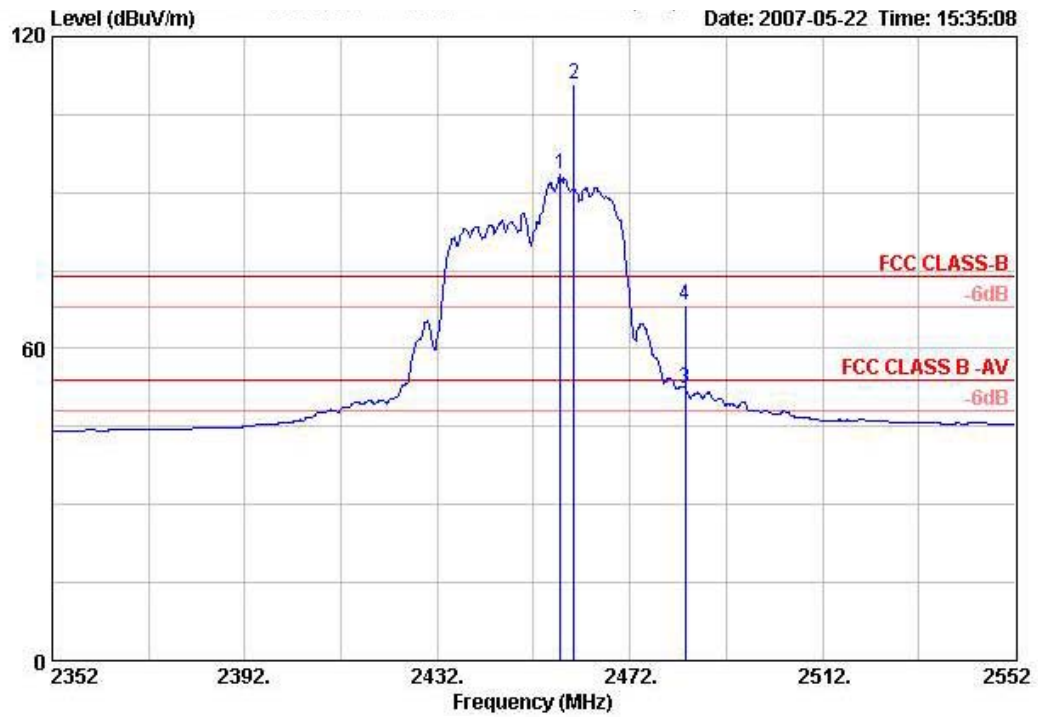

	Read	Limit	OverAntenna	Preamp	Cable	Ant	Table				
Freq	Level	Level	Line	Limit	Factor	Factor	Loss	Remark	Pos	Pos	Pol/Phase
MHz	dBuV	dBuV/m	dBuV/m	dB	dB/m	dB	dB		cm	deg	
1 *	2457.600	62.49	93.63		28.32	0.00	2.81	AVERAGE	114	171	HORIZONTAL
2 *	2460.400	79.86	111.00		28.32	0.00	2.81	PEAK	114	171	HORIZONTAL
3 *	2483.500	20.96	52.16	54.00	-1.84	28.36	0.00	2.84	114	171	HORIZONTAL
4 !	2483.500	37.19	68.39	74.00	-5.61	28.36	0.00	2.84	114	171	HORIZONTAL

Item 1, 2 are the fundamental frequency at 2452 MHz.

Note:

Emission level (dBuV/m) = 20 log Emission level (uV/m).

Corrected Reading: Antenna Factor + Cable Loss + Read Level - Preamp Factor = Level.

For Emission not in Restricted Band

Low Band Edge Plot on Configuration Drafft n MCS8 20MHz Ant. B + Ant. C / 2412 MHz

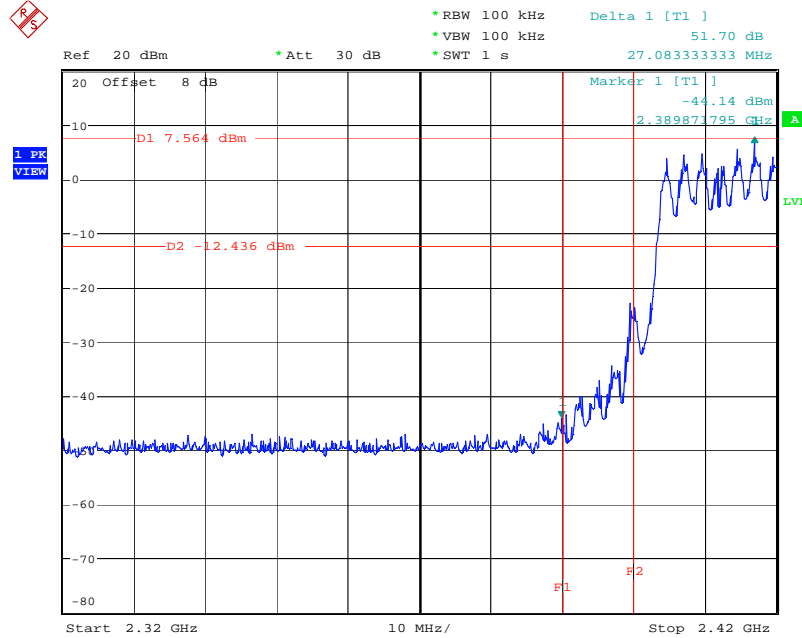

Date: 23.MAY.2007 17:07:53

High Band Edge Plot on Configuration Drafft n MCS8 20MHz Ant. B + Ant. C / 2462 MHz

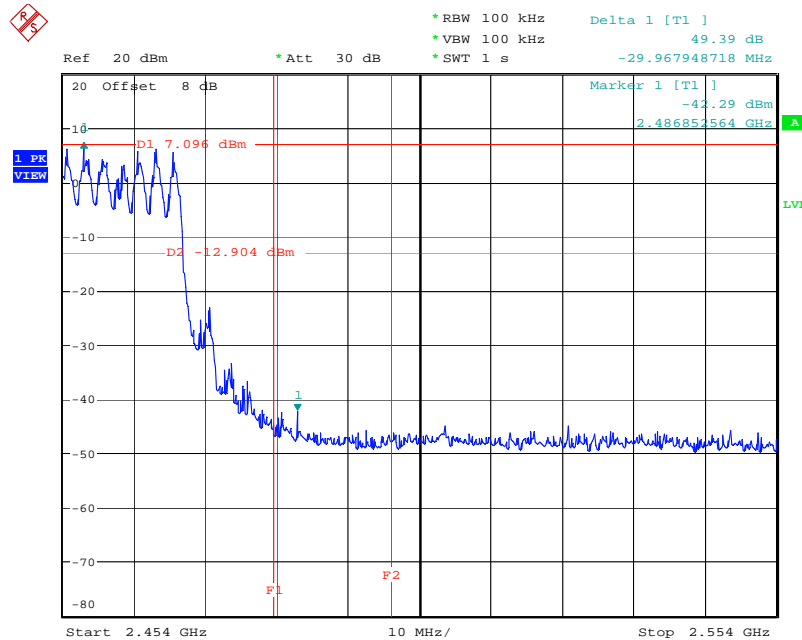

Date: 23.MAY.2007 17:04:51

For Emission not in Restricted Band

Low Band Edge Plot on Configuration Drafft n MCS8 40MHz Ant. B + Ant. C / 2422 MHz

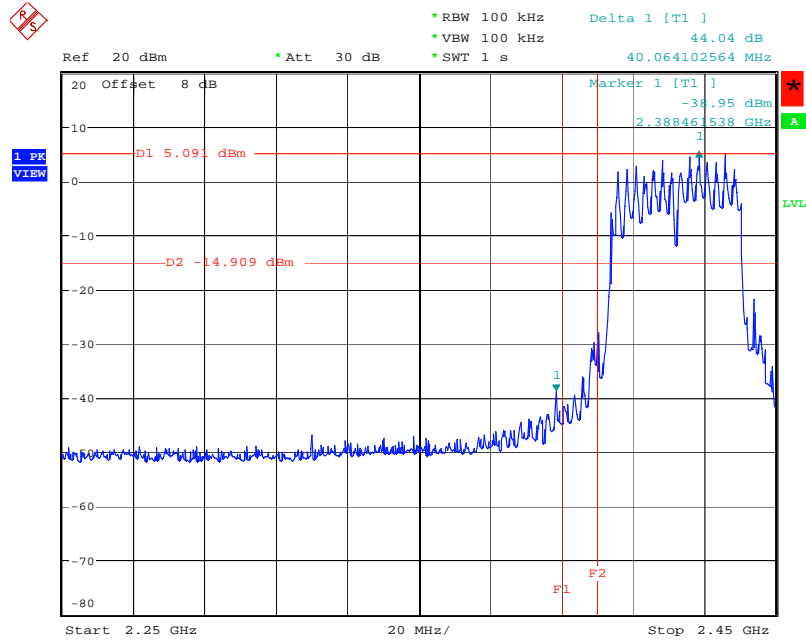

Date: 23.MAY.2007 16:46:02

High Band Edge Plot on Configuration Drafft n MCS8 40MHz Ant. B + Ant. C / 2452 MHz

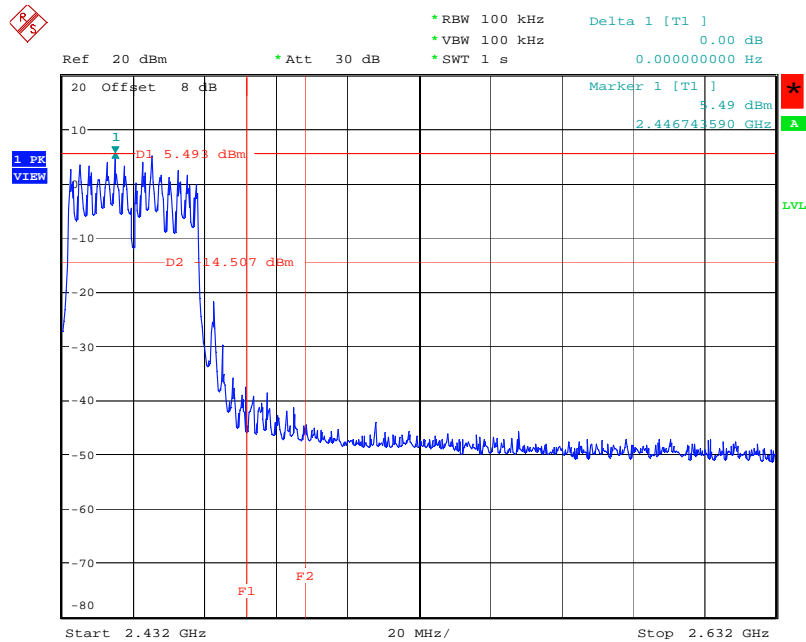

Date: 23.MAY.2007 16:43:15

4.7. Antenna Requirements

4.7.1. Limit

Except for special regulations, the Low-power Radio-frequency Devices must not be equipped with any jacket for installing an antenna with extension cable. An intentional radiator shall be designed to ensure that no antenna other than that furnished by the responsible party shall be used with the device. The use of a permanently attached antenna or of an antenna that uses a unique coupling to the intentional radiator shall be considered sufficient to comply with the provisions of this Section. The manufacturer may design the unit so that the user can replace a broken antenna, but the use of a standard antenna jack or electrical connector is prohibited. Further, this requirement does not apply to intentional radiators that must be professionally installed.

4.7.2. Antenna Connector Construction

Please refer to section 3.3 in this test report; antenna connector complied with the requirements.

5. LIST OF MEASURING EQUIPMENTS

Instrument	Manufacturer	Model No.	Serial No.	Characteristics	Calibration Date	Remark
EMC Receiver	R&S	ESCS 30	100359	9kHz – 2.75GHz	Mar. 01, 2007	Conduction (CO04-HY)
LISN	MessTec	NNB-2/16Z	99079	9kHz – 30MHz	Mar. 31, 2007	Conduction (CO04-HY)
LISN (Support Unit)	EMCO	3810/2NM	9703-1839	9kHz – 30MHz	Mar. 22, 2007	Conduction (CO04-HY)
RF Cable-CON	UTIFLEX	3102-26886-4	CB049	9kHz – 30MHz	Apr. 20, 2007	Conduction (CO04-HY)
ISN	SCHAFFNER	ISN T400	21653	9kHz – 30MHz	Mar. 27, 2007	Conduction (CO04-HY)
EMI Filter	LINDGREN	LRE-2030	2651	< 450 Hz	N/A	Conduction (CO04-HY)
Isolation Transformer	Erika Fiedler OHG	D-65396 Walluf	58	45MHz-2.15GHz	N/A	Conduction (CO04-HY)
3m Semi Anechoic Chamber	SIDT FRANKONIA	SAC-3M	03CH03-HY	30 MHz - 1 GHz 3m	Jun. 15, 2006	Radiation (03CH03-HY)
Amplifier	SCHAFFNER	CPA9231A	1886	9 kHz - 2 GHz	Jan. 22, 2007	Radiation (03CH03-HY)
Amplifier	Agilent	8449B	3008A02120	1 GHz - 26.5 GHz	May 29, 2006	Radiation (03CH03-HY)
Amplifier	MITEQ	AMF-6F-260400	923364	26.5 GHz - 40 GHz	Jan. 22, 2007*	Radiation (03CH03-HY)
Spectrum Analyzer	R&S	FSP40	100004/040	9 kHz - 40 GHz	Sep. 21, 2006	Radiation (03CH03-HY)
Loop Antenna	R&S	HFH2-Z2	860004/001	9 kHz - 30 MHz	May 23, 2006*	Radiation (03CH03-HY)
Bilog Antenna	SCHAFFNER	CBL 6112D	22237	30 MHz – 1 GHz	Jul. 24, 2006	Radiation (03CH03-HY)
Horn Antenna	EMCO	3115	6741	1GHz ~ 18GHz	May. 04, 2007	Radiation (03CH03-HY)
Horn Antenna	SCHWARZBECK	BBHA9170	BBHA9170154	15 GHz - 40 GHz	NCR	Radiation (03CH03-HY)
RF Cable-R03m	Jye Bao	RG142	CB021	30 MHz - 1 GHz	Dec. 02, 2006	Radiation (03CH03-HY)
RF Cable-HIGH	SUHNER	SUCOFLEX 106	03CH03-HY	1 GHz - 40 GHz	Dec. 02, 2006	Radiation (03CH03-HY)
Turn Table	HD	DS 420	420/650/00	0 – 360 degree	N/A	Radiation (03CH03-HY)
Antenna Mast	HD	MA 240	240/560/00	1 m - 4 m	N/A	Radiation (03CH03-HY)
Spectrum Analyzer	R&S	FSP30	100023	9kHz ~ 30GHz	Dec. 17, 2006	Conducted (TH01-HY)
Power Meter	R&S	NRVS	100764	DC ~ 40GHz	Jul. 20, 2006	Conducted (TH01-HY)
Power Sensor	R&S	NRV-Z51	100666	DC ~ 40GHz	Jul. 20, 2006	Conducted (TH01-HY)
Power Sensor	R&S	NRV-Z32	100057	30MHz ~ 6GHz	Jun. 10, 2006	Conducted (TH01-HY)
AC Power Source	HPC	HPA-500W	HPA-9100024	AC 0 ~ 300V	May. 04, 2007*	Conducted (TH01-HY)
DC Power Source	G.W.	GPC-6030D	C671845	DC 1V ~ 60V	Mar. 03, 2007	Conducted (TH01-HY)

Instrument	Manufacturer	Model No.	Serial No.	Characteristics	Calibration Date	Remark
Temp. and Humidity Chamber	KSON	THS-C3L	612	N/A	Oct. 02, 2006	Conducted (TH01-HY)
RF CABLE-1m	Jye Bao	RG142	CB034-1m	20MHz ~ 7GHz	Dec. 01, 2006	Conducted (TH01-HY)
RF CABLE-2m	Jye Bao	RG142	CB035-2m	20MHz ~ 1GHz	Dec. 01, 2006	Conducted (TH01-HY)
Oscilloscope	Tektronix	TDS1012	CO38515	100MHz / 1GS/s	Jun. 20, 2006	Conducted (TH01-HY)
Signal Generator	R&S	SMR40	100116	10MHz ~ 40GHz	Mar. 07, 2007	Conducted (TH01-HY)
Data Generator	Tektronix	DG2030	063-2920-50	0.1Hz~400MHz	Jun. 16, 2006	Conducted (TH01-HY)

Note: Calibration Interval of instruments listed above is one year.

* Calibration Interval of instruments listed above is two year.

NCR means Non-Calibration required.

6. TEST LOCATION

SHIJR	ADD : 6Fl., No. 106, Sec. 1, Shintai 5th Rd., Shijr City, Taipei, Taiwan 221, R.O.C. TEL : 886-2-2696-2468 FAX : 886-2-2696-2255
HWA YA	ADD : No. 52, Hwa Ya 1st Rd., Kwei-Shan Hsiang, Tao Yuan Hsien, Taiwan, R.O.C. TEL : 886-3-327-3456 FAX : 886-3-318-0055
LINKOU	ADD : No. 30-2, Dingfu Tsuen, Linkou Shiang, Taipei, Taiwan 244, R.O.C TEL : 886-2-2601-1640 FAX : 886-2-2601-1695
DUNGHU	ADD : No. 3, Lane 238, Kangle St., Neihu Chiu, Taipei, Taiwan 114, R.O.C. TEL : 886-2-2631-4739 FAX : 886-2-2631-9740
JUNGHE	ADD : 7Fl., No. 758, Jungjeng Rd., Junghe City, Taipei, Taiwan 235, R.O.C. TEL : 886-2-8227-2020 FAX : 886-2-8227-2626
NEIHU	ADD : 4Fl., No. 339, Hsin Hu 2 nd Rd., Taipei 114, Taiwan, R.O.C. TEL : 886-2-2794-8886 FAX : 886-2-2794-9777
JHUBEI	ADD : No.8, Lane 724, Bo-ai St., Jhubei City, HsinChu County 302, Taiwan, R.O.C. TEL : 886-3-656-9065 FAX : 886-3-656-9085

7. TAF CERTIFICATE OF ACCREDITATION



Certificate No. : L1190-070110

財團法人全國認證基金會
Taiwan Accreditation Foundation

Certificate of Accreditation

This is to certify that

Sporton International Inc.

EMC & Wireless Communications Laboratory

No.52, Hwa Ya 1st Rd., Hwa Ya Technology Park, Kwei-Shan Hsiang, Tao Yuan Hsien,
Taiwan, R.O.C.

is accredited in respect of laboratory

Accreditation Criteria	: ISO/IEC 17025:2005
Accreditation Number	: 1190
Originally Accredited	: December 15, 2003
Effective Period	: January 10, 2007 to January 09, 2010
Accredited Scope	: Testing Field, see described in the Appendix
Specific Accreditation Program	: Accreditation Program for Designated Testing Laboratory for Commodities Inspection Accreditation Program for Telecommunication Equipment Testing Laboratory



Jay-San Chen
President, Taiwan Accreditation Foundation
Date : January 10, 2007

P1, total 9 pages

The Appendix forms an integral part of this Certificate, which shall be invalid when used without the Appendix.