



SPORTON International Inc.

No. 52, Hwa Ya 1st Rd., Kwei-Shan Hsiang, TaoYuan Hsien, Taiwan, R.O.C.

Ph: 886-3-327-3456 / FAX: 886-3-327-0973 / www.sporton.com.tw

FCC RADIO TEST REPORT

Applicant's company	Netgear Incorporated
Applicant Address	4500 Great America Parkway Santa Clara, CA 95054 U.S.A.
FCC ID	PY306100037
Manufacturer's company	Gemtek Technology Co., Ltd.
Manufacturer Address	No. 1 Jen Ai Road, Hsinchu Industrial Park, Hukou, Hsinchu, Taiwan, R.O.C. 303

Product Name	RangeMax Next Wireless Router
Brand Name	NETGEAR
Model Name	WNR854T
Test Rule	47 CFR FCC Part 15 Subpart C § 15.247
Test Freq. Range	2400 ~ 2483.5MHz
Receive Date	Mar. 26, 2006
Test Date	Apr. 06, 2006
Submission Type	Original Equipment



Statement

Test result included is only for the draft 11n part of the product.

The test result in this report refers exclusively to the presented test model / sample.

Without written approval of SPORTON International Inc., the test report shall not be reproduced except in full.

The measurements and test results shown in this test report were made in accordance with the procedures and found in compliance with the limit given in **ANSI C63.4-2003** and **47 CFR FCC Part 15 Subpart C**.

The test equipment used to perform the test is calibrated and traceable to NML/ROC.

NVLAQ®

Lab Code: 200079-0



Table of Contents

1. CERTIFICATE OF COMPLIANCE	1
2. SUMMARY OF THE TEST RESULT	2
3. GENERAL INFORMATION	3
3.1. Product Details.....	3
3.2. Accessories	4
3.3. Table for Filed Antenna	5
3.4. Table for Carrier Frequencies	5
3.5. Table for Test Modes	6
3.6. Table for Testing Locations	6
3.7. Table for Supporting Units	6
3.8. Table for Parameters of Test Software Setting	7
3.9. Test Configurations	8
4. TEST RESULT	9
4.1. AC Power Line Conducted Emissions Measurement	9
4.2. Maximum Peak Output Power Measurement	15
4.3. Power Spectral Density Measurement	17
4.4. 6dB Spectrum Bandwidth Measurement	25
4.5. Radiated Emissions Measurement	33
4.6. Band Edge Emissions Measurement	65
4.7. Antenna Requirements	78
5. LIST OF MEASURING EQUIPMENTS	79
6. SPORTON COMPANY PROFILE	81
6.1. Test Location	81
7. NVLAP CERTIFICATE OF ACCREDITATION	82
APPENDIX A. PHOTOGRAPHS OF EUT	A1 ~ A14
APPENDIX B. TEST PHOTOS	B1 ~ B6
APPENDIX C. MAXIMUM PERMISSIBLE EXPOSURE	C1 ~C4



1. CERTIFICATE OF COMPLIANCE

Product Name : RangeMax Next Wireless Router
Brand Name : NETGEAR
Model Name : WNR854T
Applicant : Netgear Incorporated
Test Rule Part(s) : 47 CFR FCC Part 15 Subpart C § 15.247

Sporton International as requested by the applicant to evaluate the EMC performance of the product sample received on Mar. 26, 2006 would like to declare that the tested sample has been evaluated and found to be in compliance with the tested rule parts. The data recorded as well as the test configuration specified is true and accurate for showing the sample's EMC nature.

Mandy Liang 6.4.2006
Prepared By:
Mandy Liang / Specialist

Steven Lu 6.4.2006
Technical Acceptance By:
Steven Lu / Engineer

Wayne Hsu 6.4.06
Reviewed By:
Wayne Hsu / Supervisor



2. SUMMARY OF THE TEST RESULT

Applied Standard: 47 CFR FCC Part 15 Subpart C				
Part	Rule Section	Description of Test	Result	Under Limit
4.1	15.207	AC Power Line Conducted Emissions	Complies	2.28 dB
4.2	15.247(b)(3)	Maximum Peak Conducted Output Power	Complies	12.48 dB
4.3	15.247(e)	Power Spectral Density	Complies	23.01 dB
4.4	15.247(a)(2)	6dB Spectrum Bandwidth	Complies	-
4.5	15.247(d)	Radiated Emissions	Complies	0.38 dB
4.6	15.247(d)	Band Edge Emissions	Complies	0.95 dB
4.7	15.203	Antenna Requirements	Complies	-

Test Items	Uncertainty	Remark
AC Power Line Conducted Emissions	± 2.26 dB	Confidence levels of 95%
Maximum Peak Conducted Output Power	± 0.5 dB	Confidence levels of 95%
Power Spectral Density	± 0.71 dB	Confidence levels of 95%
6dB Spectrum Bandwidth	$\pm 6.25 \times 10^{-7}$	Confidence levels of 95%
Radiated Emissions/ Band Edge Emissions	± 3.72 dB	Confidence levels of 95%

3. GENERAL INFORMATION

3.1. Product Details

Items	Description
Product Type	WLAN
Radio Type	Intentional Transceiver
Power Type	Power Adapter
Interface Type	RJ-45
Modulation	DSSS for IEEE 802.11b ; OFDM for draft 802.11g see the below table for draft 11n
Data Modulation	DSSS (BPSK / QPSK / CCK) ; OFDM (BPSK / QPSK / 16QAM / 64QAM)
Data Rate (Mbps)	IEEE 802.11b (1/ 2/ 5.5/11) IEEE 802.11g (6/9/12/18/24/36/48/54) see the below table for draft 11n
Frequency Range	2400 ~ 2483.5MHz
Channel Number	11 for 20MHz bandwidth ; 7 for 40MHz bandwidth
Channel Band Width (99%)	MCS8(20MHz) : 17.68 MHz MCS8 (40MHz) : 36.00 MHz MCS15 (20MHz) : 17.68 MHz MCS15 (40MHz) : 36.08 MHz
Conducted Output Power	MCS8(20MHz) : 17.52 dBm MCS8 (40MHz) : 17.50 dBm MCS15 (20MHz) : 17.52 dBm MCS15 (40MHz) : 17.48 dBm
Carrier Frequencies	2412 ~ 2462 MHz
Antenna	Dipole Antenna

Bandwidth

Antenna	Single (TX)		Two (TX)		Three (RX Only)	
	20 MHz	40 MHz	20 MHz	40 MHz	20 MHz	40 MHz
802.11b	V	V	X	X	V	V
802.11g	V	V	V	V	V	V
draft 11n	V	V	V	V	V	V



draft 11n spec

MCS Index	Nss	Modulation	R	NBPS	NCBPS		NDBPS		Datarate(Mbps)			
					20MHz	40MHz	20MHz	40MHz	800nsGI		400nsGI	
									20MHz	40MHz	20MHz	40MHz
0	1	BPSK	1/2	1	52	108	26	54	6.5	13.5	7.200	15
1	1	QPSK	1/2	2	104	216	52	108	13.0	27.0	14.400	30
2	1	QPSK	3/4	2	104	216	78	162	19.5	40.5	21.700	45
3	1	16-QAM	1/2	4	208	432	104	216	26.0	54.0	28.900	60
4	1	16-QAM	3/4	4	208	432	156	324	39.0	81.0	43.300	90
5	1	64-QAM	2/3	6	312	648	208	432	52.0	108.0	57.800	120
6	1	64-QAM	3/4	6	312	648	234	486	58.5	121.5	65.000	135
7	1	64-QAM	5/6	6	312	648	260	540	65.0	135.0	72.200	150
8	2	BPSK	1/2	1	104	216	52	108	13.0	27.0	14.444	30
9	2	QPSK	1/2	2	208	432	104	216	26.0	54.0	28.889	60
10	2	QPSK	3/4	2	208	432	156	324	39.0	81.0	43.333	90
11	2	16-QAM	1/2	4	416	864	208	432	52.0	108.0	57.778	120
12	2	16-QAM	3/4	4	416	864	312	648	78.0	162.0	86.667	180
13	2	64-QAM	2/3	6	624	1296	416	864	104.0	216.0	115.556	240
14	2	64-QAM	3/4	6	624	1296	468	972	117.0	243.0	130.000	270
15	2	64-QAM	5/6	6	624	1296	520	1080	130.0	270.0	144.444	300

Symbol	Explanation
NSS	Number of spatial streams
R	Code rate
NBPS	Number of coded bits per single carrier
NCBPS	Number of coded bits per symbol
NDBPS	Number of data bits per symbol
GI	guard interval

3.2. Accessories

Power	Brand	Model	Rating
Adapter 1	NETGEAR	DSA-0151F-12	100-240VAC, 12VDC
Adapter 2	NETGEAR	MU18-2120150-A1	100-240VAC, 12VDC



3.3. Table for Filed Antenna

Ant.	Brand	Model Name	Antenna Type	Connector	Gain (dBi)
A	WHA YU	N/A	Dipole	U.FL	2dBi
B	WHA YU	N/A	Dipole	U.FL	2dBi
C	WHA YU	N/A	Dipole	U.FL	2dBi

3.4. Table for Carrier Frequencies

There are two bandwidth systems for draft 11n.

For both 20MHz bandwidth syetems, use Channel 1~Channel 11.

For both 40MHz bandwidth syetems, use Channel 3~Channel 9.

Frequency Band	Channel No.	Frequency	Channel No.	Frequency
2400~2483.5MHz	1	2412 MHz	7	2442 MHz
	2	2417 MHz	8	2447 MHz
	3	2422 MHz	9	2452 MHz
	4	2427 MHz	10	2457 MHz
	5	2432 MHz	11	2462 MHz
	6	2437 MHz		

For draft 11n, the two TX Ant. A & Ant. C could transmit simultaneously.



3.5. Table for Test Modes

Preliminary tests were performed in different data rate to find the worst radiated emission. The data rate shown in the table below is the worst-case rate with respect to the specific test item. Investigation has been done on all the possible configurations for searching the worst cases. The following table is a list of the test modes shown in this test report.

Test Items	Mode	Channel	Antenna
AC Power Line Conducted Emissions	Normal Link	6	A
Maximum Peak Conducted Output Power Power Spectral Density 6dB Spectrum Bandwidth	MCS8/20MHz	1/6/11	A+B
	MCS8/40MHz	3/6/9	A+B
	MCS15/20MHz	1/6/11	A+B
	MCS15/40MHz	3/6/9	A+B
Radiated Emissions 9kHz~1GHz	11n/BPSK	6	A
Radiated Emissions 1GHz~10 th Harmonic	MCS8/20MHz	1/6/11	A+B
	MCS8/40MHz	3/6/9	A+B
	MCS15/20MHz	1/6/11	A+B
	MCS15/40MHz	3/6/9	A+B
Band Edge Emissions	MCS8/20MHz	1/11	A+B
	MCS8/40MHz	3/9	A+B
	MCS15/20MHz	1/11	A+B
	MCS15/40MHz	3/9	A+B

3.6. Table for Testing Locations

Test Site No.	Site Category	Location	FCC Reg. No.	IC File No.	VCCI Reg. No
03CH03-HY	SAC	Hwa Ya	101377	IC 4088	-
CO04-HY	Conduction	Hwa Ya	101377	IC 4088	-
TH01-HY	OVEN Room	Hwa Ya	-	-	-

Open Area Test Site (OATS); Semi Anechoic Chamber (SAC); Fully Anechoic Chamber (FAC).

Please refer section 6 for Test Site Address.

3.7. Table for Supporting Units

Support Unit	Brand	Model	FCC ID
Printer	EPSON	LQ-300	DOC
Modem	ACEEX	DM-1414	IFAXDM1414
Notebook *2	DELL	PP01L	DOC

3.8. Table for Parameters of Test Software Setting

During testing, Channel & Power Controlling Software provided by the customer was used to control the operating channel as well as the output power level. The RF output power selection is for the setting of RF output power expected by the customer and is going to be fixed on the firmware of the final end product.

Power Parameters of draft 11n MCS8 20MHz Ant. A + Ant. B

Test Software Version	Hyper Terminal		
Frequency	2412 MHz	2437 MHz	2462 MHz
IEEE 802.11n	57	56	55

Power Parameters of draft 11n MCS8 40MHz Ant. A + Ant. B

Test Software Version	Hyper Terminal		
Frequency	2422 MHz	2437 MHz	2452 MHz
IEEE 802.11n	52	51	50

Power Parameters of draft 11n MCS15 20MHz Ant. A + Ant. B

Test Software Version	Hyper Terminal		
Frequency	2412 MHz	2437 MHz	2462 MHz
IEEE 802.11n	57	56	55

Power Parameters of draft 11n MCS15 40MHz Ant. A + Ant. B

Test Software Version	Hyper Terminal		
Frequency	2422 MHz	2437 MHz	2452 MHz
IEEE 802.11n	57	56	55

3.9. Test Configurations

3.9.1. Radiation Emissions Test Configuration

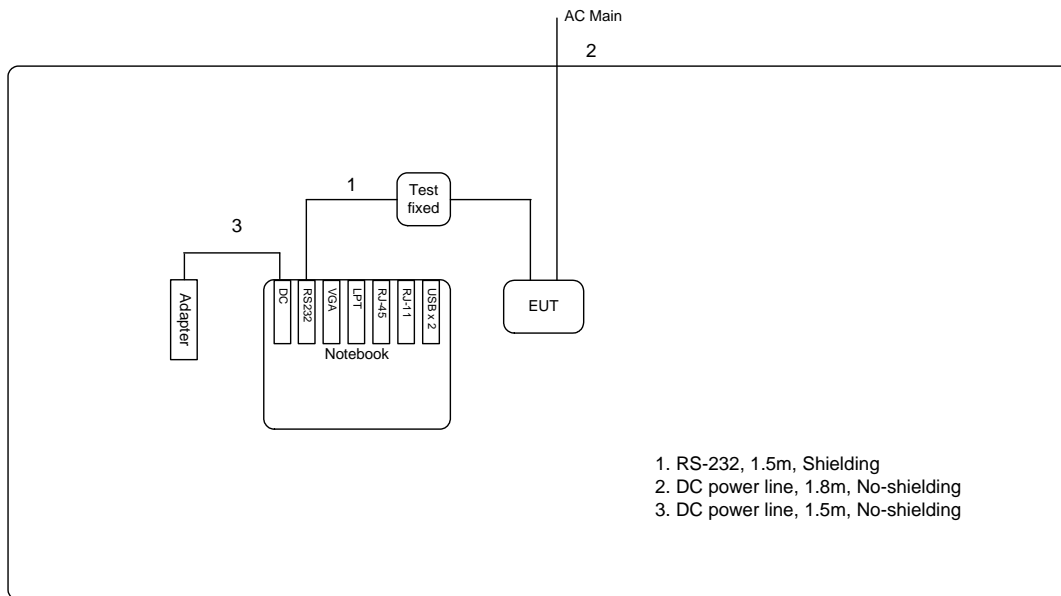

3.9.2. AC Power Line Conduction Emissions Test Configuration

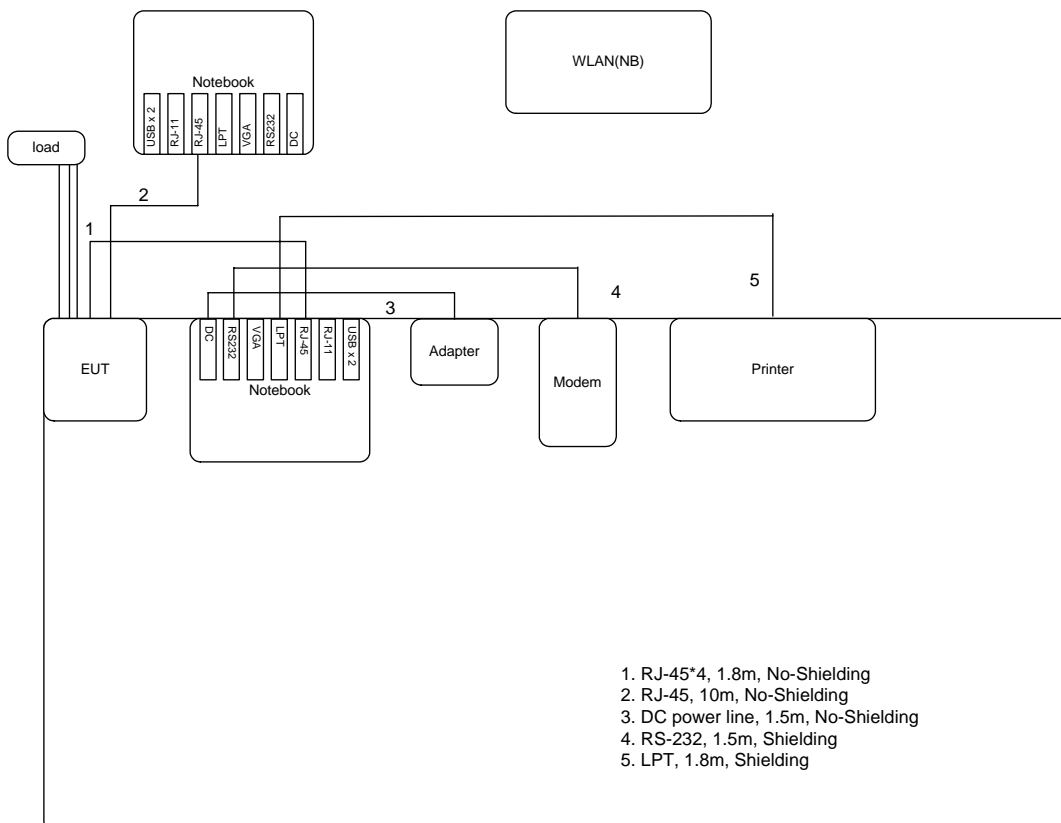

4. TEST RESULT

4.1. AC Power Line Conducted Emissions Measurement

4.1.1. Limit

For a Low-power Radio-frequency Device which is designed to be connected to the AC power line, the radio frequency voltage that is conducted back onto the AC power line on any frequency or frequencies within the band 150 kHz to 30 MHz shall not exceed below limits table.

Frequency (MHz)	QP Limit (dBuV)	AV Limit (dBuV)
0.15~0.5	66~56	56~46
0.5~5	56	46
5~30	60	50

4.1.2. Measuring Instruments and Setting

Please refer to section 5 in this report. The following table is the setting of the receiver.

Receiver Parameters	Setting
Attenuation	10 dB
Start Frequency	0.15 MHz
Stop Frequency	30 MHz
IF Bandwidth	9 KHz

4.1.3. Test Procedures

1. Configure the EUT according to ANSI C63.4. The EUT or host of EUT has to be placed 0.4 meter far from the conducting wall of the shielding room and at least 80 centimeters from any other grounded conducting surface.
2. Connect EUT or host of EUT to the power mains through a line impedance stabilization network (LISN).
3. All the support units are connected to the other LISNs. The LISN should provide 50uH/50ohms coupling impedance.
4. The frequency range from 150 KHz to 30 MHz was searched.
5. Set the test-receiver system to Peak Detect Function and Specified Bandwidth with Maximum Hold Mode.
6. The measurement has to be done between each power line and ground at the power terminal.

4.1.4. Test Setup Layout

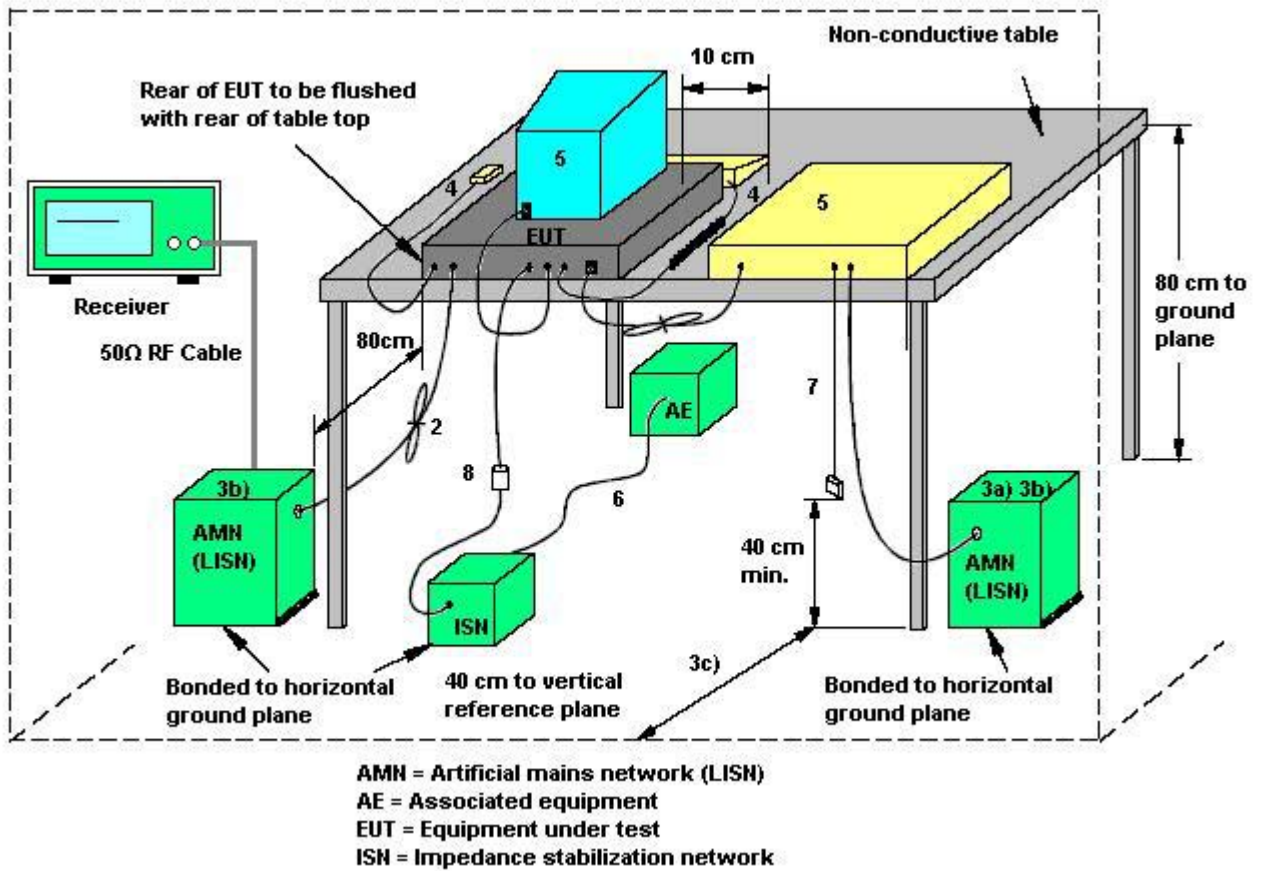

1. If cables, which hang closer than 40 cm to the horizontal metal groundplane, cannot be shortened to appropriate length, the excess shall be folded back and forth forming a bundle 30 cm to 40 cm long.
2. Excess mains cord shall be bundled in the centre or shortened to appropriate length.
3. EUT is connected to one artificial mains network (AMN). All AMNs and ISNs may alternatively be connected to a vertical reference plane or metal wall.
4. All other units of a system are powered from a second AMN. A multiple outlet strip can be used for multiple mains cords.
5. AMN and ISN are 80 cm from the EUT and at least 80 cm from other units and other metal planes.
6. Mains cords and signal cables shall be positioned for their entire lengths, as far as possible, at 40 cm from the vertical reference plane.
7. Cables of hand operated devices, such as keyboards, mice, etc. shall be placed as for normal usage.
8. Peripherals shall be placed at a distance of 10 cm from each other and from the controller, except for the monitor which, if this is an acceptable installation practice, shall be placed directly on the top of the controller.
9. I/O signal cable intended for external connection.
10. The end of the I/O signal cables which are not connected to an AE may be terminated, if required, using correct terminating impedance.
11. If used, the current probe shall be placed at 0,1 m from the ISN.

4.1.5. Test Deviation

There is no deviation with the original standard.

4.1.6. EUT Operation during Test

The EUT was placed on the test table and programmed in normal function.

4.1.7. Results of AC Power Line Conducted Emissions Measurement

Temperature	20°C	Humidity	70%
Test Engineer	Evelyn Shih	Phase	Line
Configuration	Normal Link draft 11n Channel 6		

Adapter 1

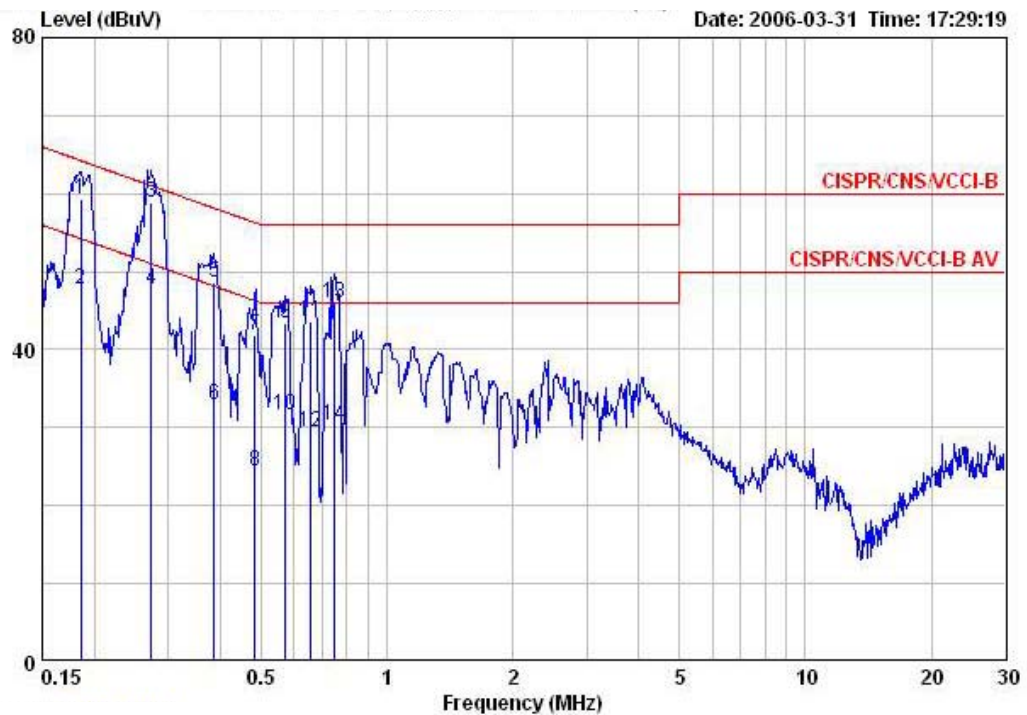

	Freq	Level	Over Limit	Limit Line	Read Level	LISN Factor	Cable Loss	Remark
	MHz	dBuV	dB	dBuV	dBuV	dB	dB	
1	0.18541	59.21	-5.03	64.24	57.64	1.37	0.20	QP
2	0.18541	47.72	-6.52	54.24	46.15	1.37	0.20	AVERAGE
3	0.27297	58.75	-2.28	61.03	57.68	0.87	0.20	QP
4	0.27297	47.64	-3.39	51.03	46.57	0.87	0.20	AVERAGE
5	0.38724	48.59	-9.53	58.12	47.79	0.60	0.20	QP
6	0.38724	32.90	-15.22	48.12	32.10	0.60	0.20	AVERAGE
7	0.48257	41.93	-14.36	56.29	41.33	0.50	0.10	QP
8	0.48257	24.41	-21.88	46.29	23.81	0.50	0.10	AVERAGE
9	0.57313	43.33	-12.67	56.00	42.73	0.40	0.20	QP
10	0.57313	31.64	-14.36	46.00	31.04	0.40	0.20	AVERAGE
11	0.65620	43.53	-12.47	56.00	42.93	0.40	0.20	QP
12	0.65620	29.44	-16.56	46.00	28.84	0.40	0.20	AVERAGE
13	0.75094	46.01	-9.99	56.00	45.51	0.30	0.20	QP
14	0.75094	30.27	-15.73	46.00	29.77	0.30	0.20	AVERAGE



Temperature	20°C	Humidity	70%
Test Engineer	Evelyn Shih	Phase	Neutral
Configuration	Normal Link draft 11n Channel 6		

Adapter 1

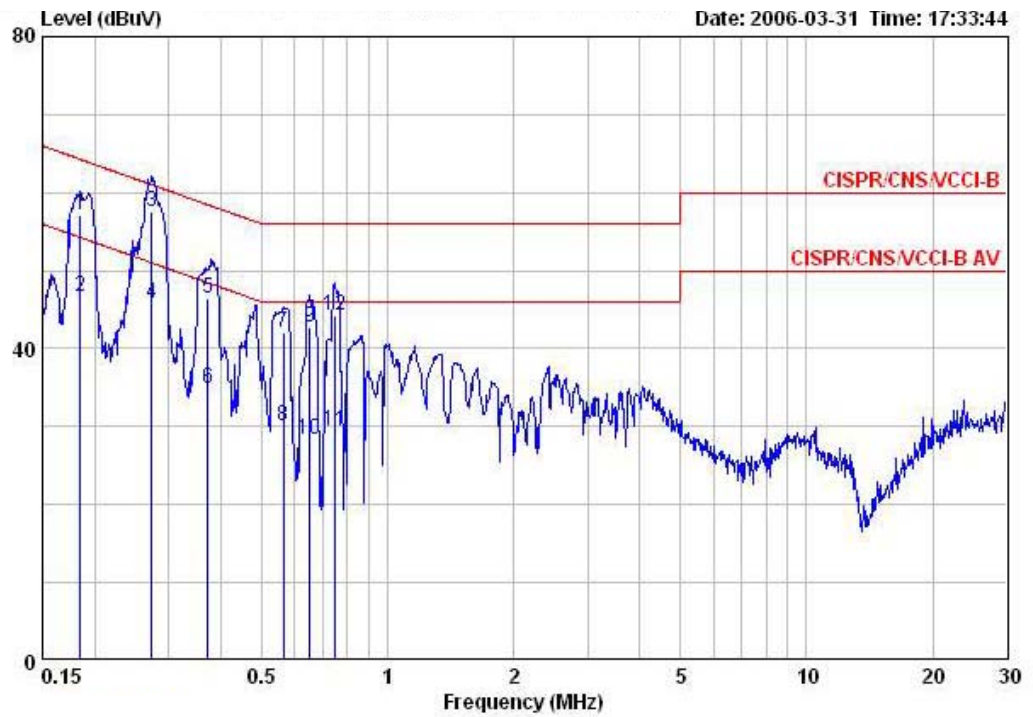

	Freq	Level	Over Limit	Limit Line	Read Level	LISN Factor	Cable Loss	Remark
	MHz	dBuV	dB	dBuV	dBuV	dB	dB	
1	0.18443	57.18	-7.10	64.28	55.71	1.27	0.20	QP
2	0.18443	46.68	-7.60	54.28	45.21	1.27	0.20	AVERAGE
3	0.27297	57.57	-3.46	61.03	56.67	0.70	0.20	QP
4	0.27297	45.86	-5.17	51.03	44.96	0.70	0.20	AVERAGE
5	0.37174	46.38	-12.08	58.46	45.68	0.50	0.20	QP
6	0.37174	34.78	-13.68	48.46	34.08	0.50	0.20	AVERAGE
7	0.56409	42.15	-13.85	56.00	41.65	0.30	0.20	QP
8	0.56409	30.07	-15.93	46.00	29.57	0.30	0.20	AVERAGE
9	0.65084	42.69	-13.31	56.00	42.19	0.30	0.20	QP
10	0.65084	28.27	-17.73	46.00	27.77	0.30	0.20	AVERAGE
11	0.75094	29.41	-16.59	46.00	28.91	0.30	0.20	AVERAGE
12	0.75094	44.21	-11.79	56.00	43.71	0.30	0.20	QP



Temperature	20°C	Humidity	70%
Test Engineer	Evelyn Shih	Phase	Line
Configuration	Normal Link draft 11n Channel 6		

Adapter 2

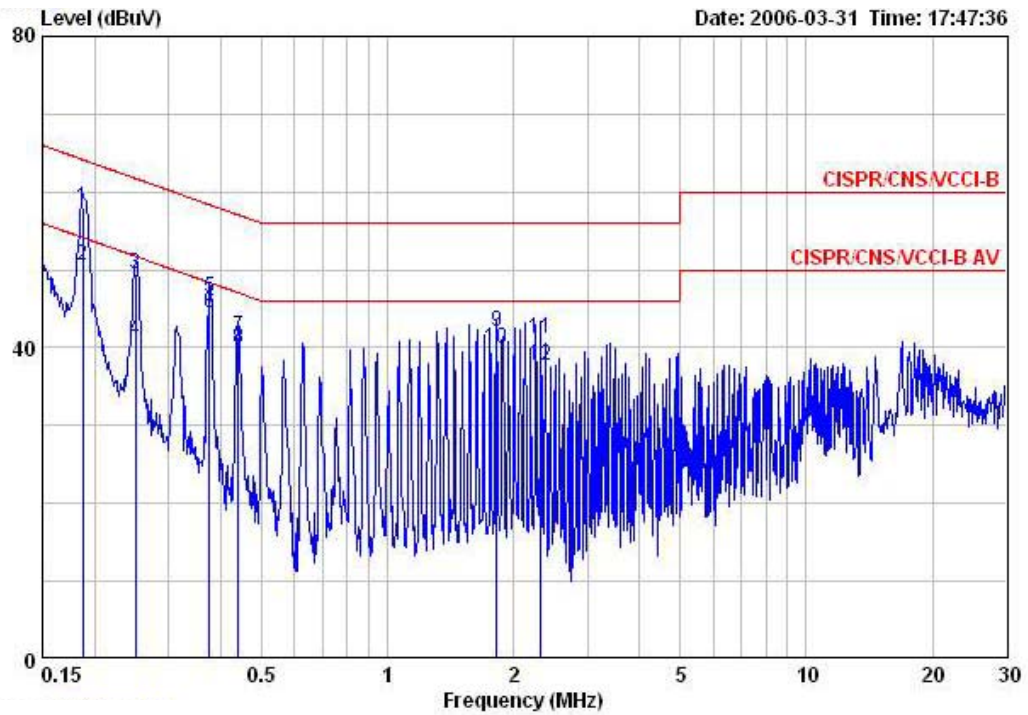

	Freq	Level	Over Limit	Limit Line	Read Level	LISN Factor	Cable Loss	Remark
	MHz	dBuV	dB	dBuV	dBuV	dB	dB	
1	0.18739	57.88	-6.27	64.15	56.42	1.26	0.20	QP
2	0.18739	50.58	-3.57	54.15	49.12	1.26	0.20	AVERAGE
3	0.25078	49.39	-12.34	61.73	48.29	0.90	0.20	QP
4	0.25078	41.08	-10.65	51.73	39.98	0.90	0.20	AVERAGE
5	0.37499	46.46	-11.93	58.39	45.66	0.60	0.20	QP
6	0.37499	44.40	-3.99	48.39	43.60	0.60	0.20	AVERAGE
7	0.43974	41.32	-15.75	57.07	40.62	0.50	0.20	QP
8	0.43974	39.86	-7.21	47.07	39.16	0.50	0.20	AVERAGE
9	1.819	42.11	-13.89	56.00	41.64	0.30	0.17	QP
10	1.819	39.91	-6.09	46.00	39.44	0.30	0.17	AVERAGE
11	2.321	41.16	-14.84	56.00	40.66	0.30	0.20	QP
12	2.321	37.75	-8.25	46.00	37.25	0.30	0.20	AVERAGE



Temperature	20°C	Humidity	70%
Test Engineer	Evelyn Shih	Phase	Neutral
Configuration	Normal Link draft 11n Channel 6		

Adapter 2

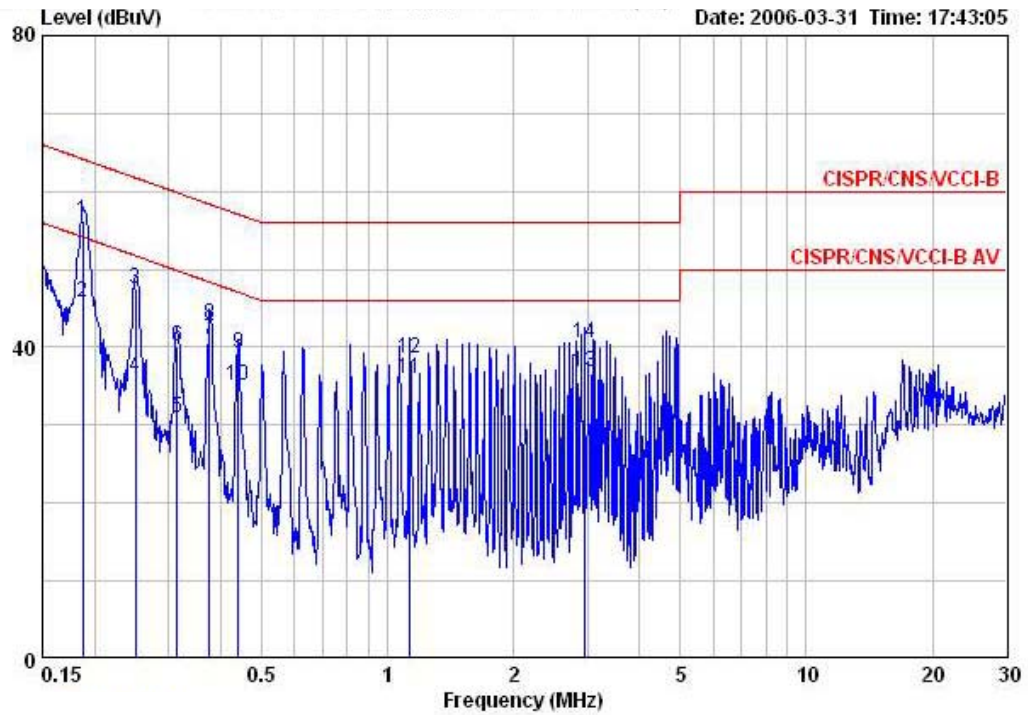

	Freq	Level	Over Limit	Limit Line	Read Level	LISN Factor	Cable Loss	Remark
	MHz	dBuV	dB	dBuV	dBuV	dB	dB	
1	0.18739	56.33	-7.83	64.15	54.99	1.14	0.20	QP
2	0.18739	45.81	-8.35	54.15	44.47	1.14	0.20	AVERAGE
3	0.25078	47.59	-14.14	61.73	46.59	0.80	0.20	QP
4	0.25078	36.22	-15.51	51.73	35.22	0.80	0.20	AVERAGE
5	0.31495	31.04	-18.80	49.84	30.19	0.65	0.20	AVERAGE
6	0.31495	40.02	-19.82	59.84	39.17	0.65	0.20	QP
7	0.37512	40.88	-7.51	48.39	40.18	0.50	0.20	AVERAGE
8	0.37512	42.97	-15.42	58.39	42.27	0.50	0.20	QP
9	0.43974	39.24	-17.83	57.07	38.64	0.40	0.20	QP
10	0.43974	35.00	-12.07	47.07	34.40	0.40	0.20	AVERAGE
11	1.129	36.06	-9.94	46.00	35.59	0.30	0.17	AVERAGE
12	1.129	38.65	-17.35	56.00	38.18	0.30	0.17	QP
13	2.946	36.88	-9.12	46.00	36.38	0.30	0.20	AVERAGE
14	2.946	40.62	-15.38	56.00	40.12	0.30	0.20	QP

Note:

Level = Read Level + LISN Factor + Cable Loss.

4.2. Maximum Peak Output Power Measurement

4.2.1. Limit

For systems using digital modulation in the 2400-2483.5MHz, the limit for peak output power is 30dBm. The limited has to be reduced by the amount in dB that the gain of the antenna exceed 6dBi. In case of point-to-point operation, the limit has to be reduced by 1dB for every 3dB that the directional gain of the antenna exceeds 6dBi.

4.2.2. Measuring Instruments and Setting

Please refer to section 5 in this report. The following table is the setting of the power meter.

Power Meter Parameter	Setting
Filter No.	Auto
Measurement time	0.135 s ~ 26 s
Used Peak Sensor	NRV-Z32 (model 04)

4.2.3. Test Procedures

1. The transmitter output (antenna port) was connected to the power meter.
2. Turn on the EUT and power meter and then record the peak power value.
3. Repeat above procedures on all channels needed to be tested.

4.2.4. Test Setup Layout

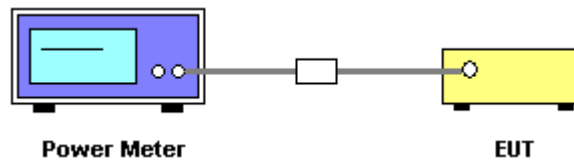

4.2.5. Test Deviation

There is no deviation with the original standard.

4.2.6. EUT Operation during Test

The EUT was programmed to be in continuously transmitting mode.

4.2.7. Test Result of Maximum Peak Output Power

Temperature	20°C	Humidity	70%
Test Engineer	Leo Hung	Configurations	draft 11n

Configuration draft 11n MCS8 20MHz Ant. A + Ant. B

Channel	Frequency	Conducted Power (dBm)	Max. Limit (dBm)	Result
1	2412 MHz	17.46	30.00	Complies
6	2437 MHz	17.50	30.00	Complies
11	2462 MHz	17.52	30.00	Complies

Configuration draft 11n MCS8 40MHz Ant. A + Ant. B

Channel	Frequency	Conducted Power (dBm)	Max. Limit (dBm)	Result
3	2422 MHz	17.34	30.00	Complies
6	2437 MHz	17.48	30.00	Complies
9	2452 MHz	17.50	30.00	Complies

Configuration draft 11n MCS15 20MHz Ant. A + Ant. B

Channel	Frequency	Conducted Power (dBm)	Max. Limit (dBm)	Result
1	2412 MHz	17.46	30.00	Complies
6	2437 MHz	17.48	30.00	Complies
11	2462 MHz	17.52	30.00	Complies

Configuration draft 11n MCS15 40MHz Ant. A + Ant. B

Channel	Frequency	Conducted Power (dBm)	Max. Limit (dBm)	Result
3	2422 MHz	17.42	30.00	Complies
6	2437 MHz	17.44	30.00	Complies
9	2452 MHz	17.48	30.00	Complies

4.3. Power Spectral Density Measurement

4.3.1. Limit

For digitally modulated systems, the power spectral density conducted from the intentional radiator to the antenna shall not be greater than 8 dBm in any 3 kHz band during any time interval of continuous transmission.

4.3.2. Measuring Instruments and Setting

Please refer to section 5 in this report. The following table is the setting of Spectrum Analyzer.

Spectrum Parameter	Setting
Attenuation	Auto
Span Frequency	1.5MHz
RB	3 kHz
VB	30 kHz
Detector	Peak
Trace	Max Hold
Sweep Time	500s

4.3.3. Test Procedures

1. The transmitter output (antenna port) was connected to the spectrum analyser.
2. Set RBW of spectrum analyzer to 3kHz and VBW to 30kHz. Set Detector to Peak, Trace to Max Hold.
3. Mark the frequency with maximum peak power as the center of the display of the spectrum.
4. Set the span to 1.5MHz and the sweep time to 500s and record the maximum peak value.

4.3.4. Test Setup Layout

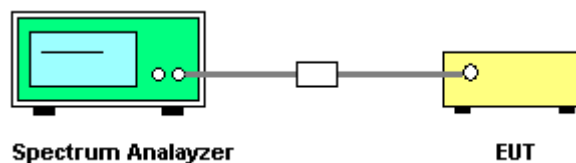

4.3.5. Test Deviation

There is no deviation with the original standard.



4.3.6. EUT Operation during Test

The EUT was programmed to be in continuously transmitting mode.

4.3.7. Test Result of Power Spectral Density

Temperature	20°C	Humidity	70%
Test Engineer	Leo Hung	Configurations	draft 11n

Configuration draft 11n MCS8 20MHz Ant. A + Ant. B

Channel	Frequency	Power Density (dBm)	Max. Limit (dBm)	Result
1	2412 MHz	-17.07	8.00	Complies
6	2437 MHz	-15.76	8.00	Complies
11	2462 MHz	-16.03	8.00	Complies

Configuration draft 11n MCS8 40MHz Ant. A + Ant. B

Channel	Frequency	Power Density (dBm)	Max. Limit (dBm)	Result
3	2422 MHz	-16.64	8.00	Complies
6	2437 MHz	-15.60	8.00	Complies
9	2452 MHz	-17.57	8.00	Complies

Configuration draft 11n MCS15 20MHz Ant. A + Ant. B

Channel	Frequency	Power Density (dBm)	Max. Limit (dBm)	Result
1	2412 MHz	-16.39	8.00	Complies
6	2437 MHz	-15.01	8.00	Complies
11	2462 MHz	-16.74	8.00	Complies

Configuration draft 11n MCS15 40MHz Ant. A + Ant. B

Channel	Frequency	Power Density (dBm)	Max. Limit (dBm)	Result
3	2422 MHz	-16.64	8.00	Complies
6	2437 MHz	-16.13	8.00	Complies
9	2452 MHz	-16.66	8.00	Complies



Power Density Plot on Configuration draft 11n MCS8 20MHz Ant. A + Ant. B / 2412 MHz

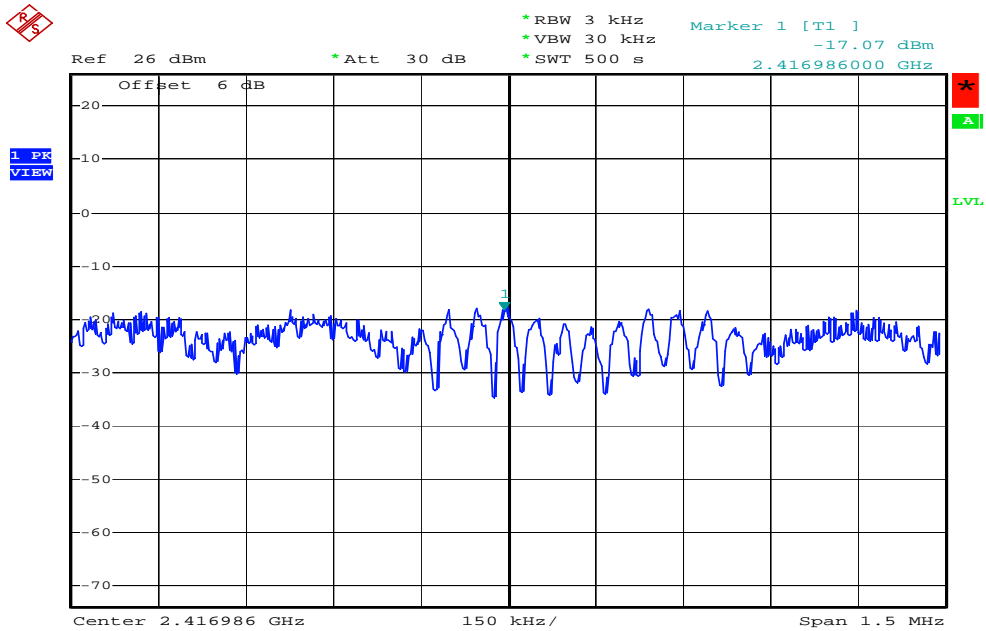

Date: 4.APR.2006 18:29:23

Power Density Plot on Configuration draft 11n MCS8 20MHz Ant. A + Ant. B / 2437 MHz

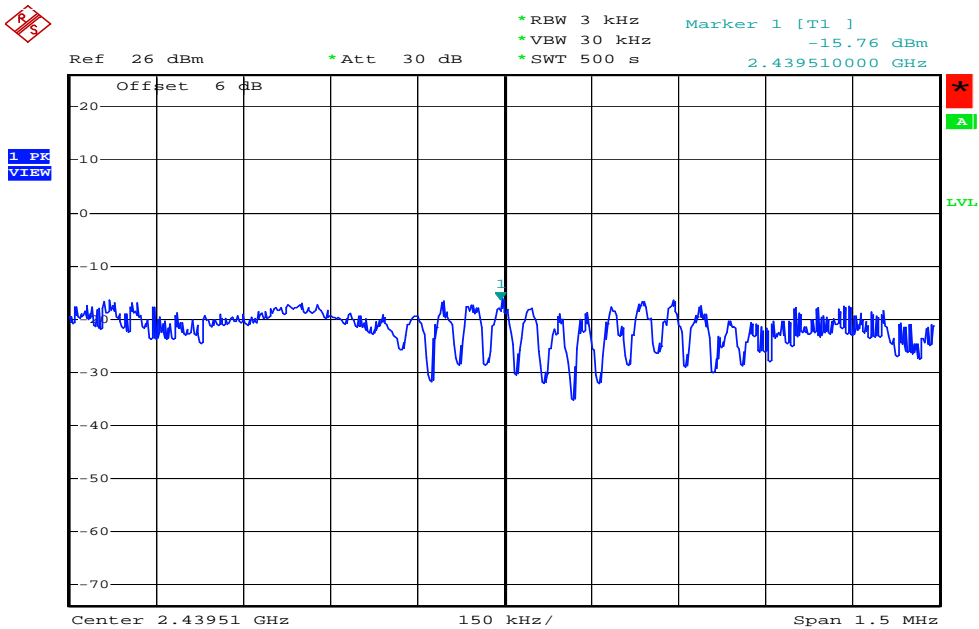

Date: 3.APR.2006 19:52:58



Power Density Plot on Configuration draft 11n MCS8 20MHz Ant. A + Ant. B / 2462 MHz

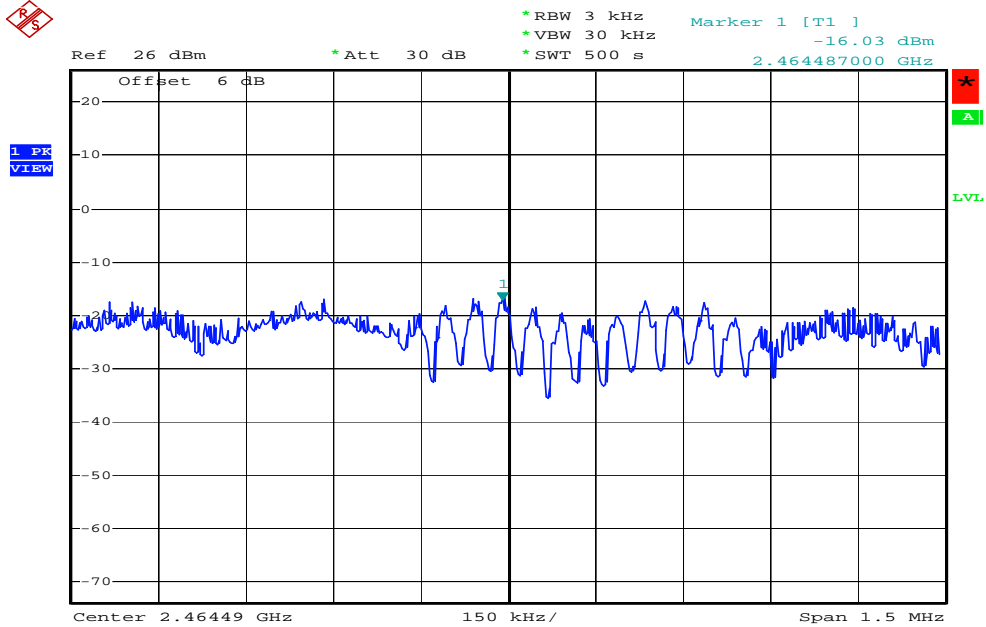

Date: 4.APR.2006 18:31:14

Power Density Plot on Configuration draft 11n MCS8 40MHz Ant. A + Ant. B / 2422 MHz

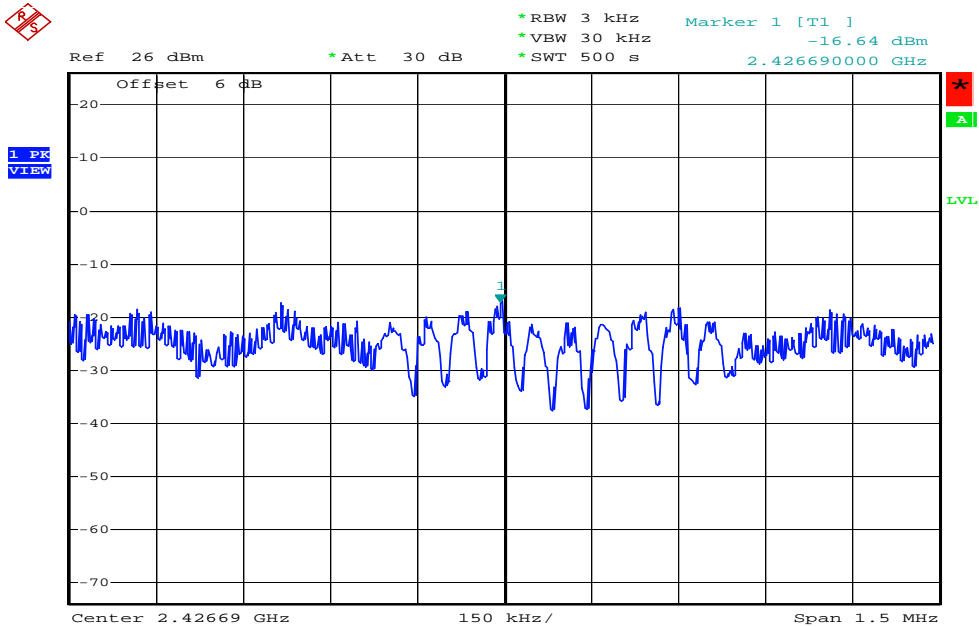

Date: 3.APR.2006 19:28:59



Power Density Plot on Configuration draft 11n MCS8 40MHz Ant. A + Ant. B / 2437 MHz

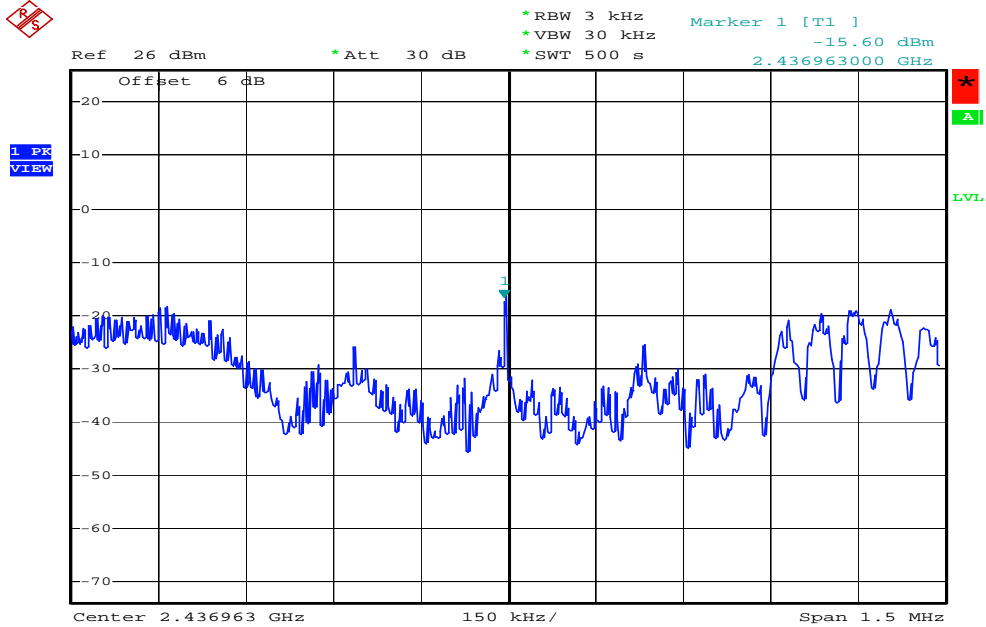

Date: 3.APR.2006 19:31:36

Power Density Plot on Configuration draft 11n MCS8 40MHz Ant. A + Ant. B / 2452 MHz

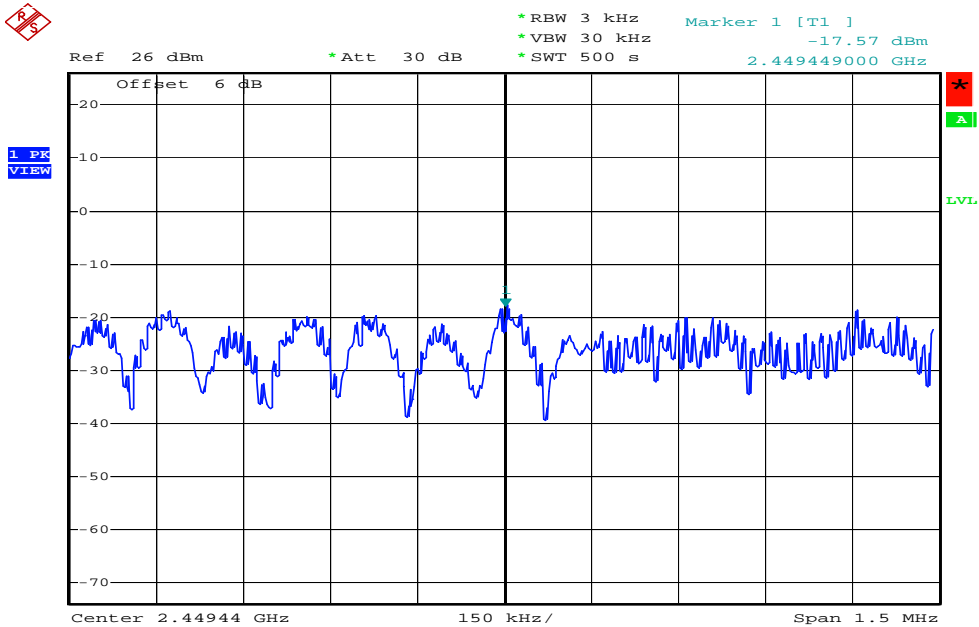

Date: 3.APR.2006 19:36:31



Power Density Plot on Configuration draft 11n MCS15 20MHz Ant. A + Ant. B / 2412 MHz

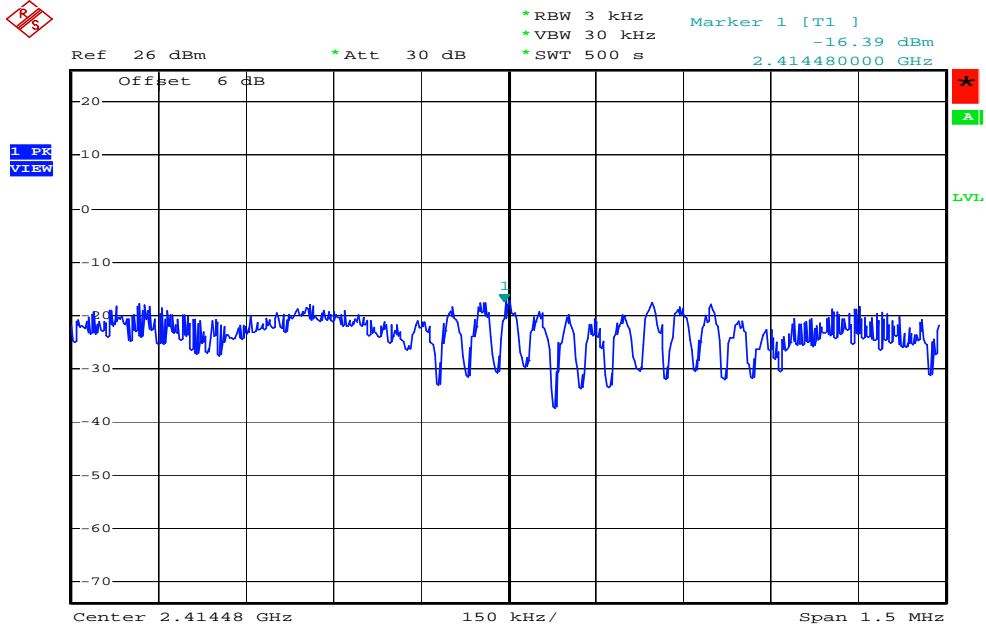

Date: 4.APR.2006 18:49:23

Power Density Plot on Configuration draft 11n MCS15 20MHz Ant. A + Ant. B / 2437 MHz

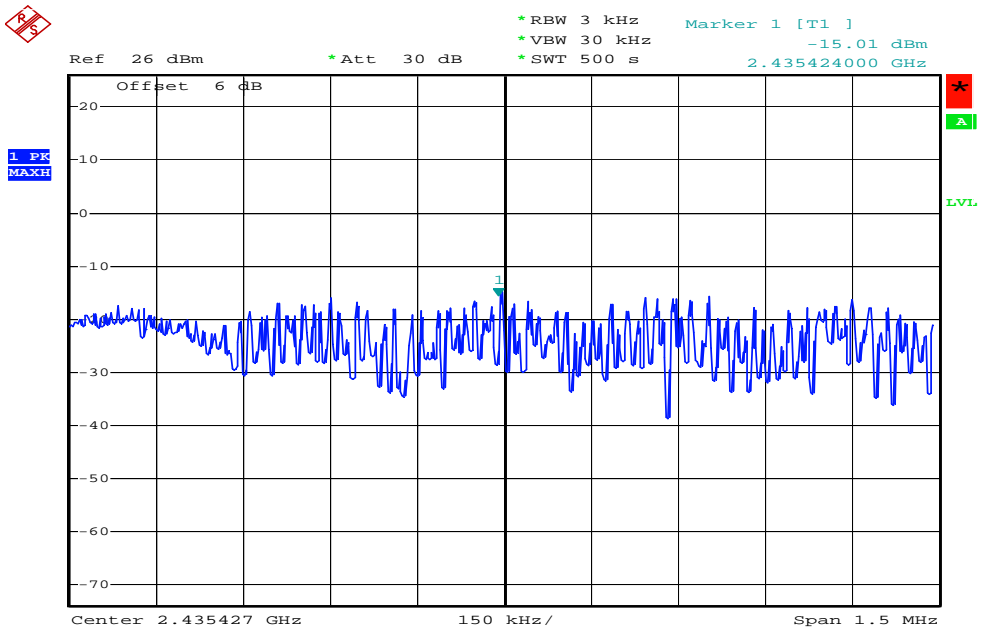

Date: 3.APR.2006 20:02:21



Power Density Plot on Configuration draft 11n MCS15 20MHz Ant. A + Ant. B / 2462 MHz

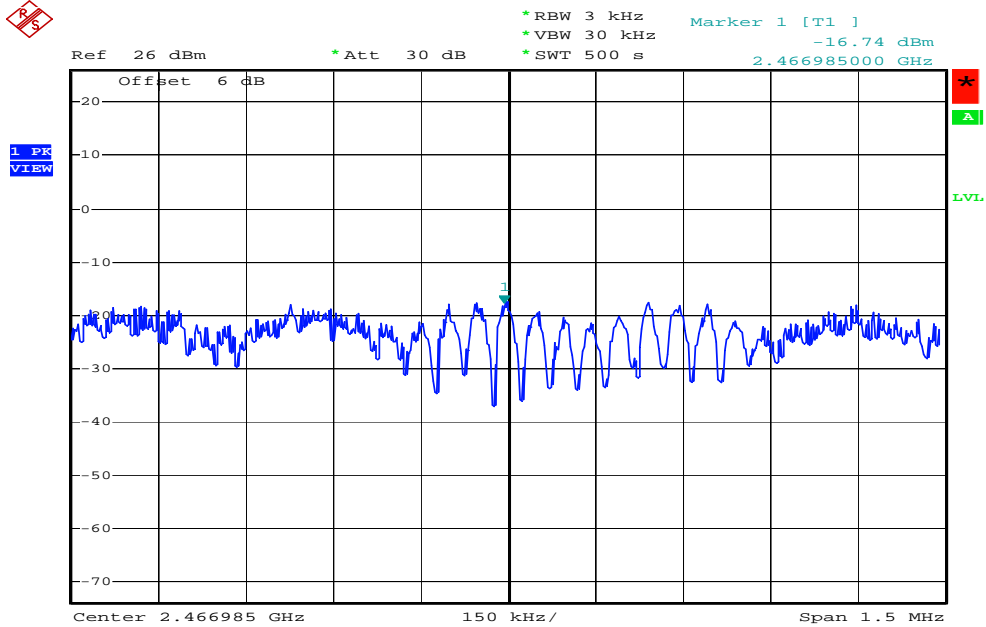

Date: 4.APR.2006 18:42:55

Power Density Plot on Configuration draft 11n MCS15 40MHz Ant. A + Ant. B / 2422 MHz

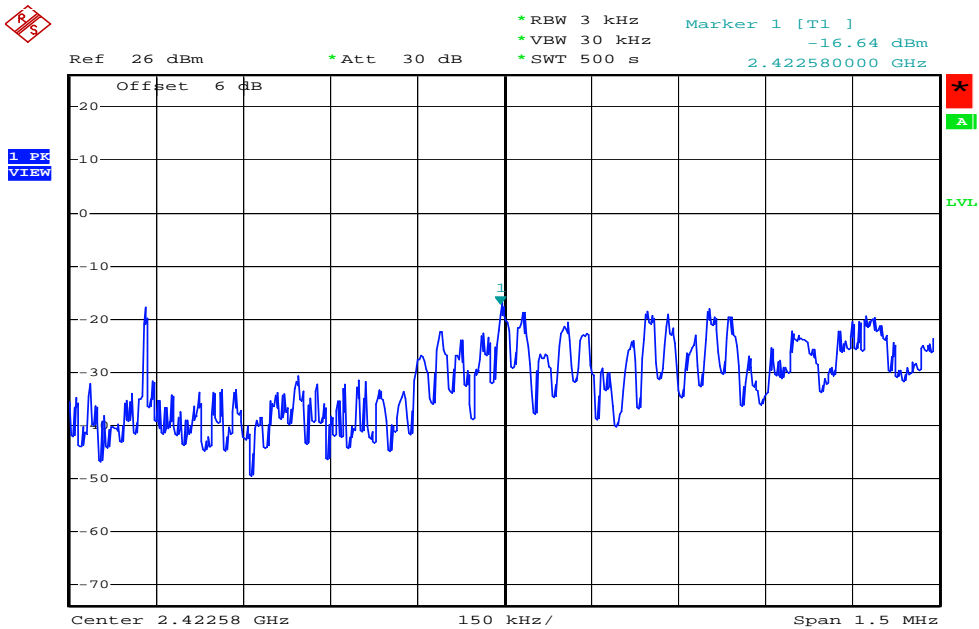

Date: 3.APR.2006 19:40:40



Power Density Plot on Configuration draft 11n MCS15 40MHz Ant. A + Ant. B / 2437 MHz

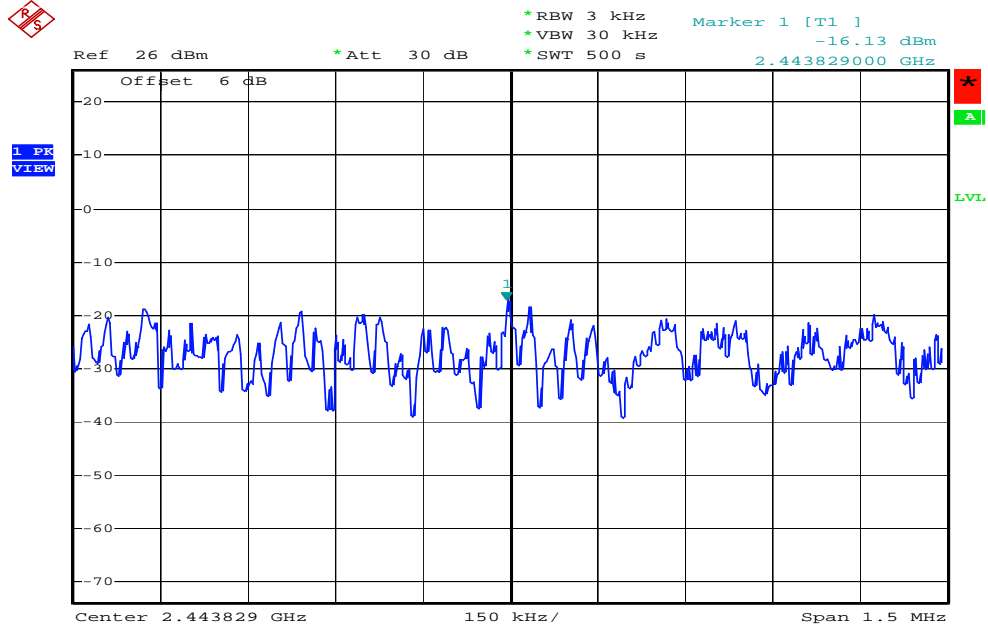

Date: 3.APR.2006 19:42:21

Power Density Plot on Configuration draft 11n MCS15 40MHz Ant. A + Ant. B / 2452 MHz

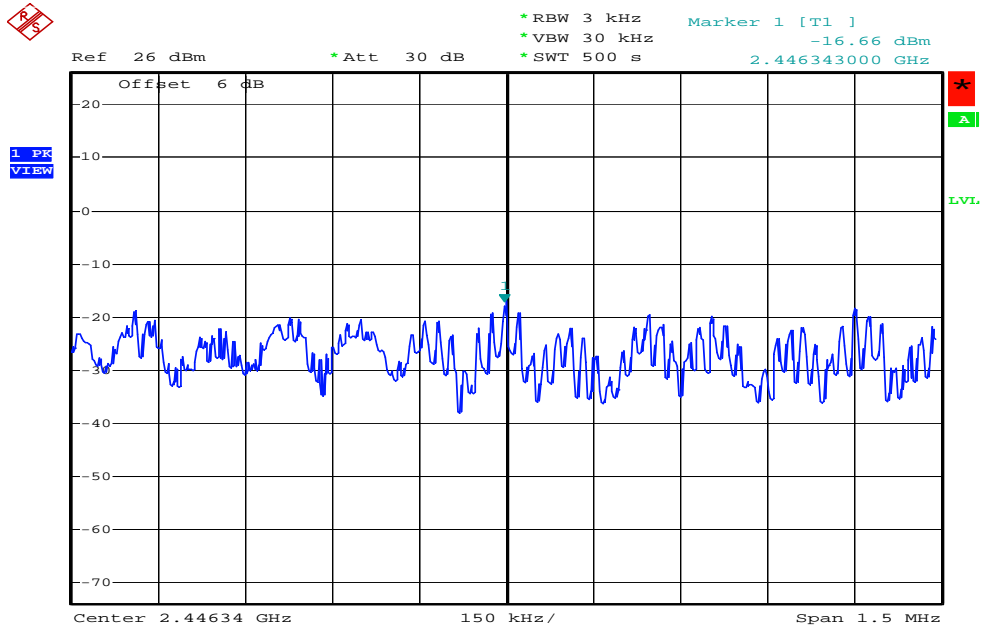

Date: 3.APR.2006 19:44:43

4.4. 6dB Spectrum Bandwidth Measurement

4.4.1. Limit

For digital modulation systems, the minimum 6 dB bandwidth shall be at least 500 kHz.

4.4.2. Measuring Instruments and Setting

Please refer to section 5 in this report. The following table is the setting of the Spectrum Analyzer.

Spectrum Parameters	Setting
Attenuation	Auto
Span Frequency	> 6dB Bandwidth
RB	100 kHz
VB	100 kHz
Detector	Peak
Trace	Max Hold
Sweep Time	Auto

4.4.3. Test Procedures

1. The transmitter output (antenna port) was connected to the spectrum analyser in peak hold mode.
2. The resolution bandwidth of 100 kHz and the video bandwidth of 100 kHz were used.
3. Measured the spectrum width with power higher than 6dB below carrier.

4.4.4. Test Setup Layout

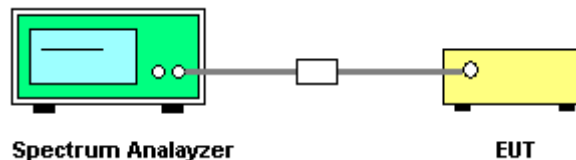

4.4.5. Test Deviation

There is no deviation with the original standard.

4.4.6. EUT Operation during Test

The EUT was programmed to be in continuously transmitting mode.

4.4.7. Test Result of 6dB Spectrum Bandwidth

Temperature	20°C	Humidity	70%
Test Engineer	Leo Hung	Configurations	draft 11n

Configuration draft 11n MCS8 20MHz Ant. A + Ant. B

Channel	Frequency	6dB Bandwidth (MHz)	99% Occupied Bandwidth (MHz)	Min. Limit (kHz)	Test Result
1	2412 MHz	17.72	17.68	500	Complies
6	2437 MHz	17.76	17.64	500	Complies
11	2462 MHz	17.72	17.68	500	Complies

Configuration draft 11n MCS8 40MHz Ant. A + Ant. B

Channel	Frequency	6dB Bandwidth (MHz)	99% Occupied Bandwidth (MHz)	Min. Limit (kHz)	Test Result
3	2422 MHz	30.16	35.92	500	Complies
6	2437 MHz	35.20	35.68	500	Complies
9	2452 MHz	35.44	36.00	500	Complies

Configuration draft 11n MCS15 20MHz Ant. A + Ant. B

Channel	Frequency	6dB Bandwidth (MHz)	99% Occupied Bandwidth (MHz)	Min. Limit (kHz)	Test Result
1	2412 MHz	17.72	17.68	500	Complies
6	2437 MHz	17.72	17.64	500	Complies
11	2462 MHz	17.72	17.68	500	Complies

Configuration draft 11n MCS15 40MHz Ant. A + Ant. B

Channel	Frequency	6dB Bandwidth (MHz)	99% Occupied Bandwidth (MHz)	Min. Limit (kHz)	Test Result
3	2422 MHz	31.28	35.68	500	Complies
6	2437 MHz	33.68	35.92	500	Complies
9	2452 MHz	35.84	36.08	500	Complies



6 dB Bandwidth Plot on Configuration draft 11n MCS8 20MHz Ant. A + Ant. B / 2412 MHz

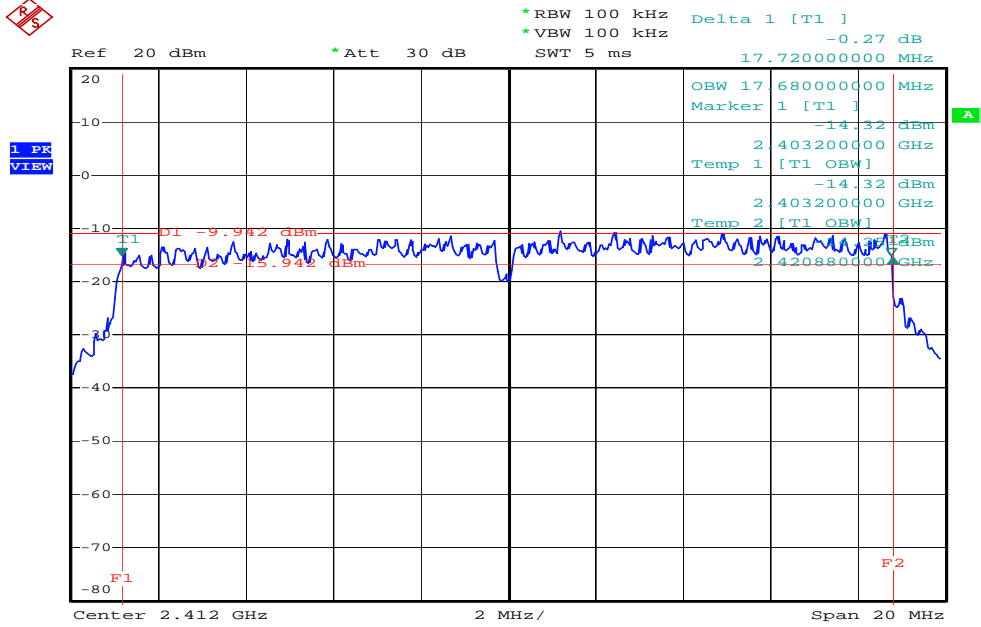

Date: 4.APR.2006 18:27:06

6 dB Bandwidth Plot on Configuration draft 11n MCS8 20MHz Ant. A + Ant. B / 2437 MHz

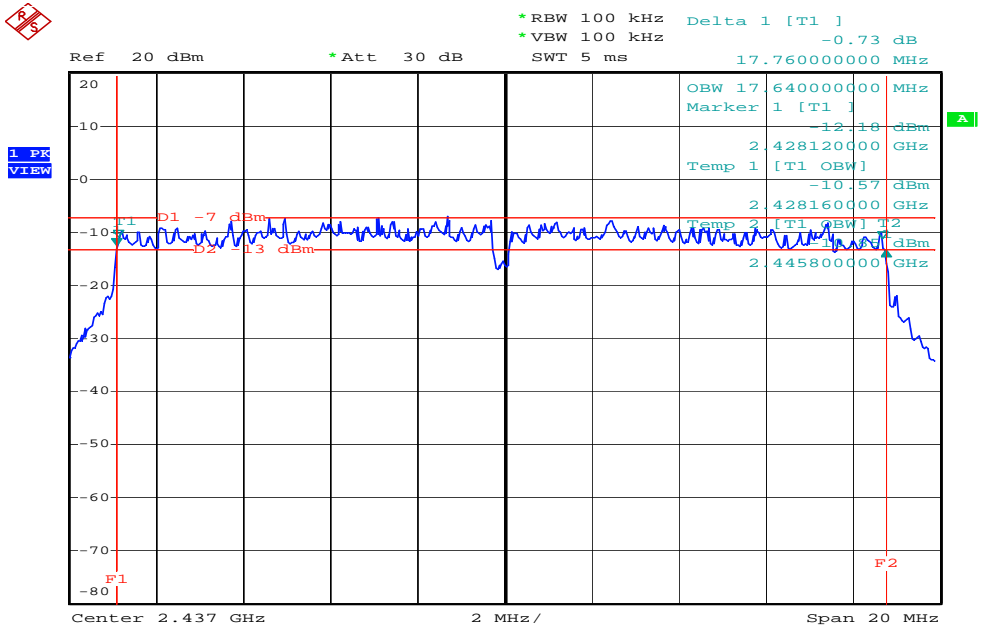

Date: 3.APR.2006 19:52:22



6 dB Bandwidth Plot on Configuration draft 11n MCS8 20MHz Ant. A + Ant. B / 2462 MHz

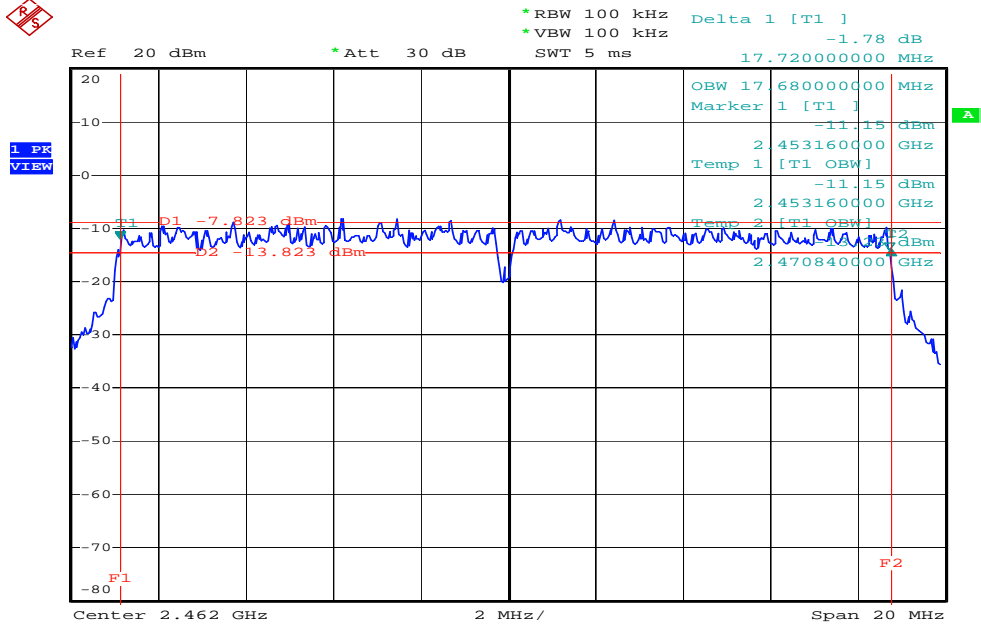

6 dB Bandwidth Plot on Configuration draft 11n MCS8 40MHz Ant. A + Ant. B / 2422 MHz

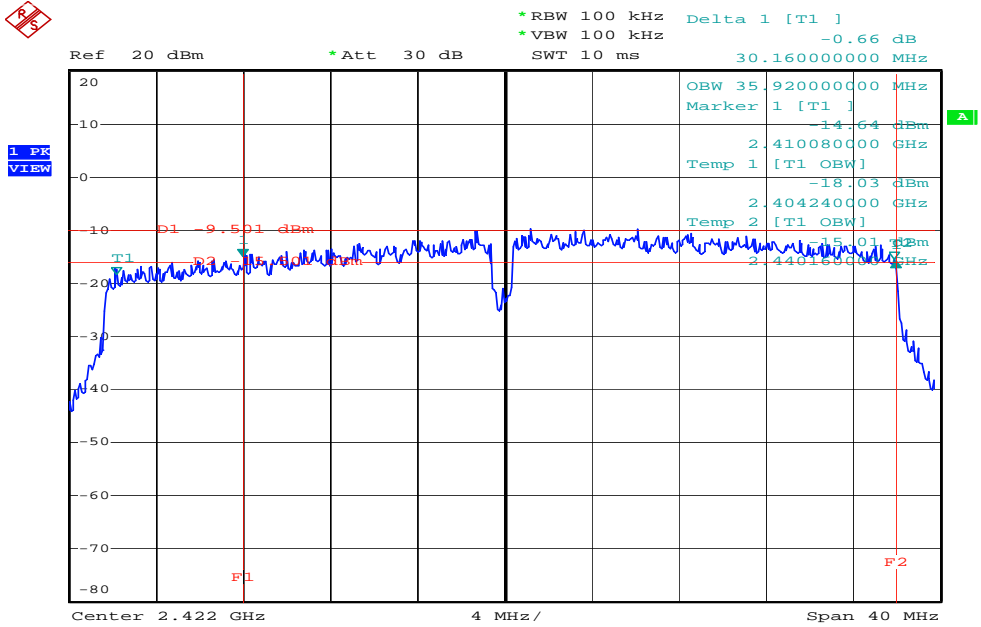



6 dB Bandwidth Plot on Configuration draft 11n MCS8 40MHz Ant. A + Ant. B / 2437 MHz

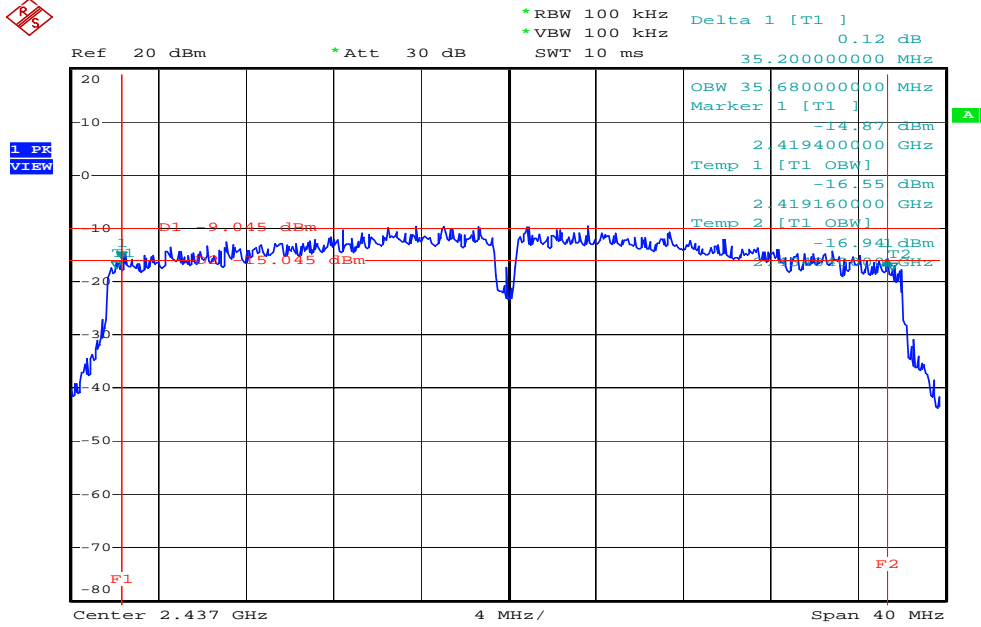

Date: 3.APR.2006 19:30:46

6 dB Bandwidth Plot on Configuration draft 11n MCS8 40MHz Ant. A + Ant. B / 2452 MHz

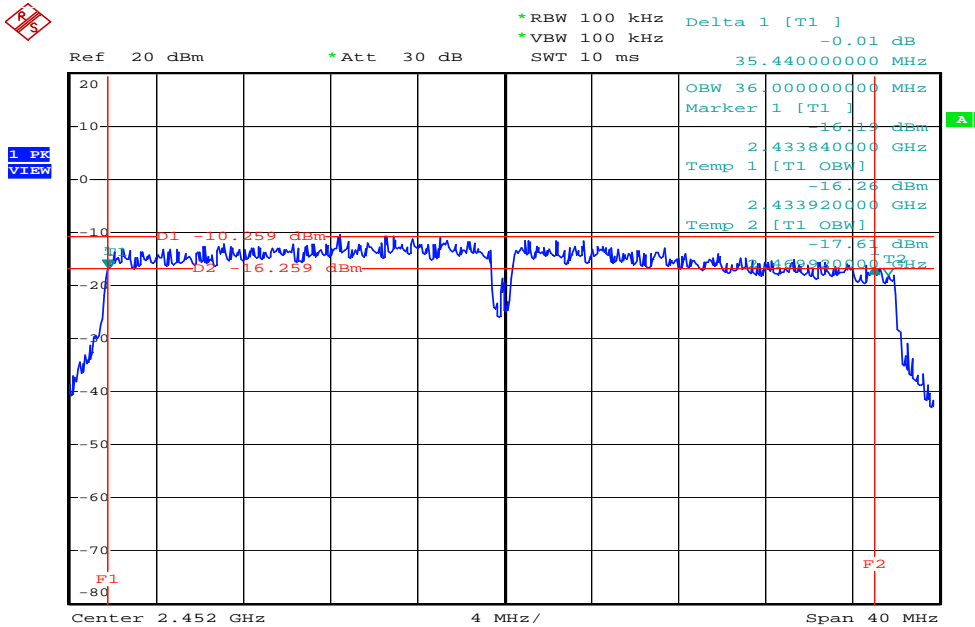

Date: 3.APR.2006 19:34:40



6 dB Bandwidth Plot on Configuration draft 11n MCS15 20MHz Ant. A + Ant. B / 2412 MHz

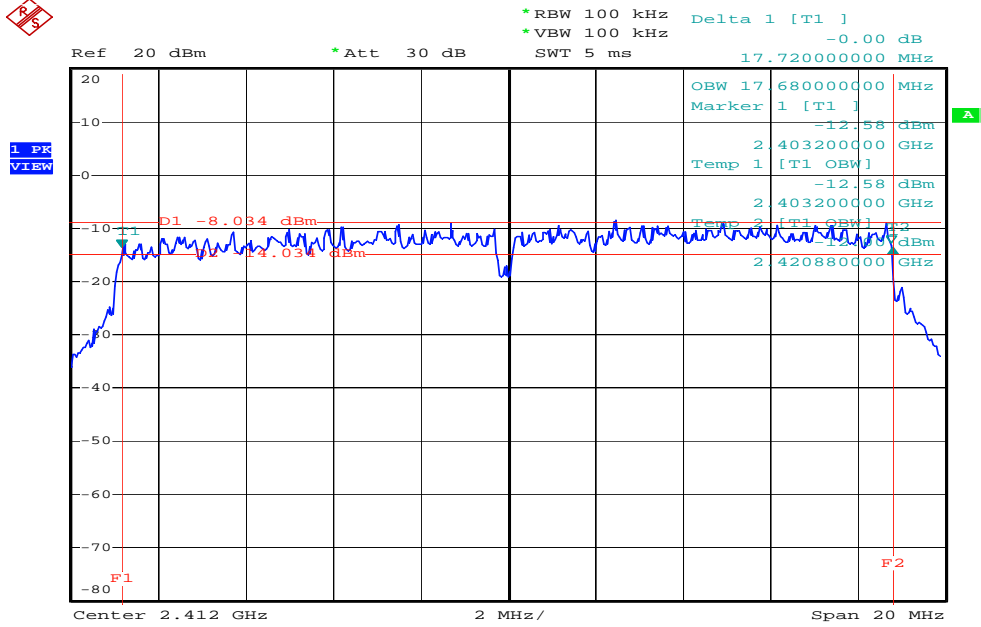

Date: 4.APR.2006 18:47:52

6 dB Bandwidth Plot on Configuration draft 11n MCS15 20MHz Ant. A + Ant. B / 2437 MHz

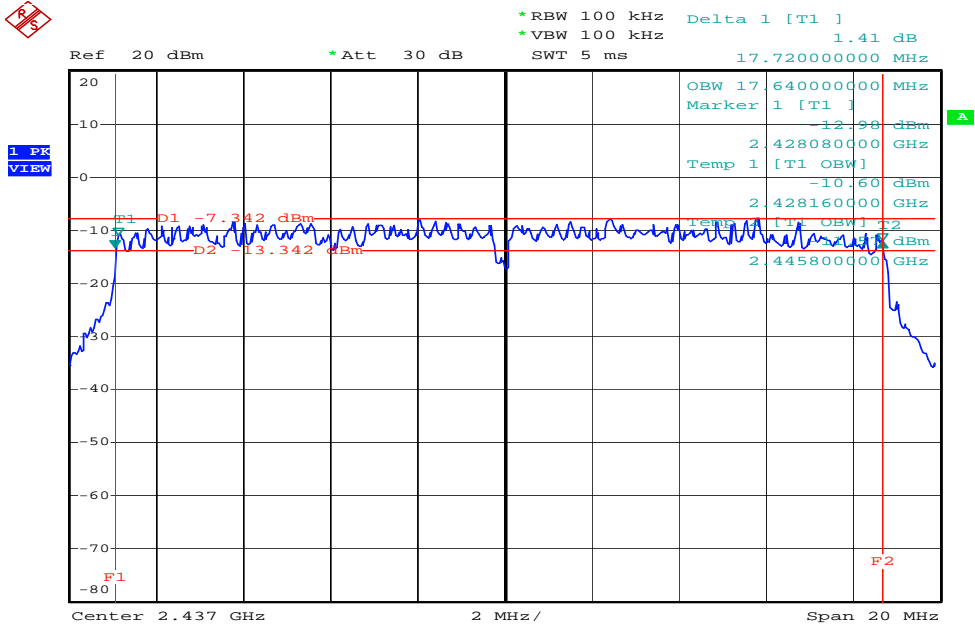

Date: 3.APR.2006 20:01:11



6 dB Bandwidth Plot on Configuration draft 11n MCS15 20MHz Ant. A + Ant. B / 2462 MHz

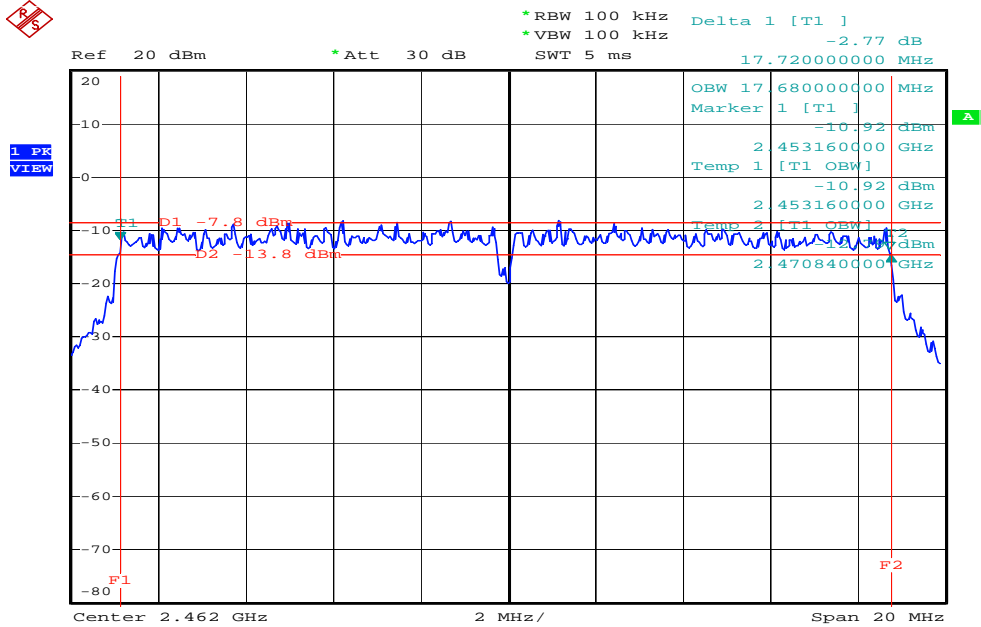

Date: 4.APR.2006 18:39:47

6 dB Bandwidth Plot on Configuration draft 11n MCS15 40MHz Ant. A + Ant. B / 2422 MHz

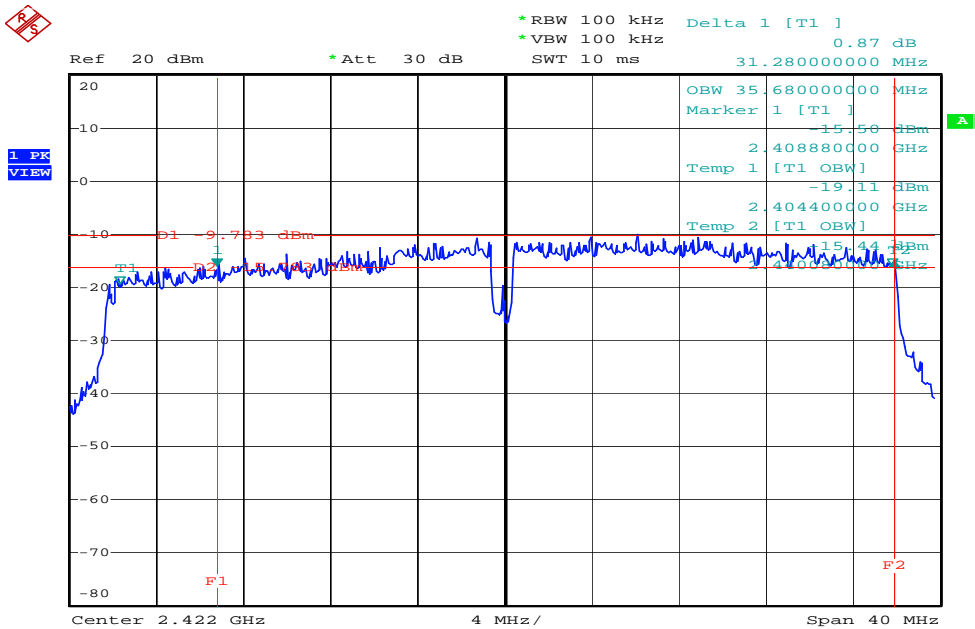

Date: 3.APR.2006 19:39:08



6 dB Bandwidth Plot on Configuration draft 11n MCS15 40MHz Ant. A + Ant. B / 2437 MHz

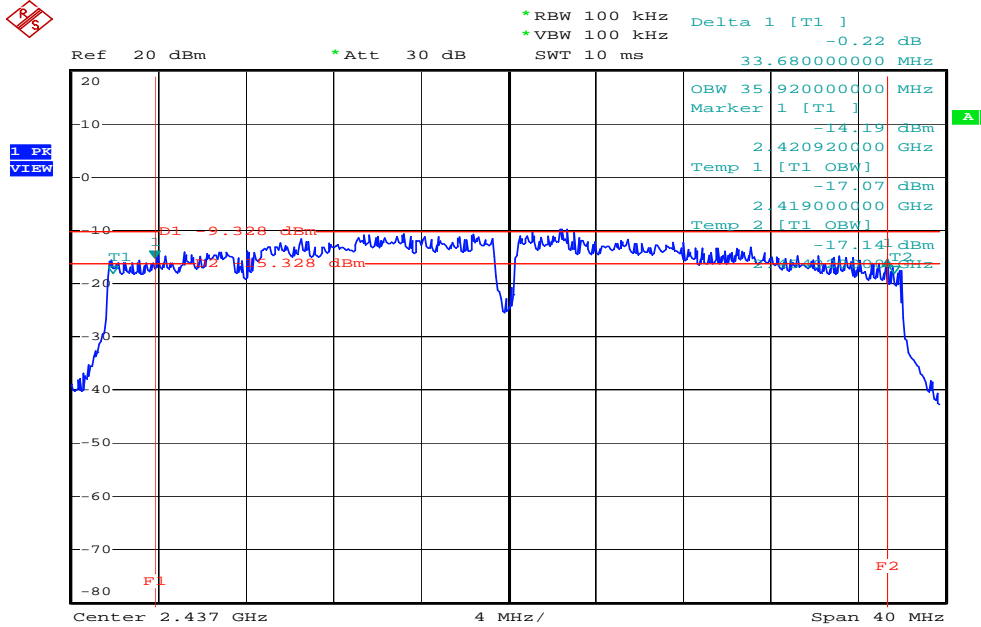

Date: 3.APR.2006 19:41:44

6 dB Bandwidth Plot on Configuration draft 11n MCS15 40MHz Ant. A + Ant. B / 2452 MHz

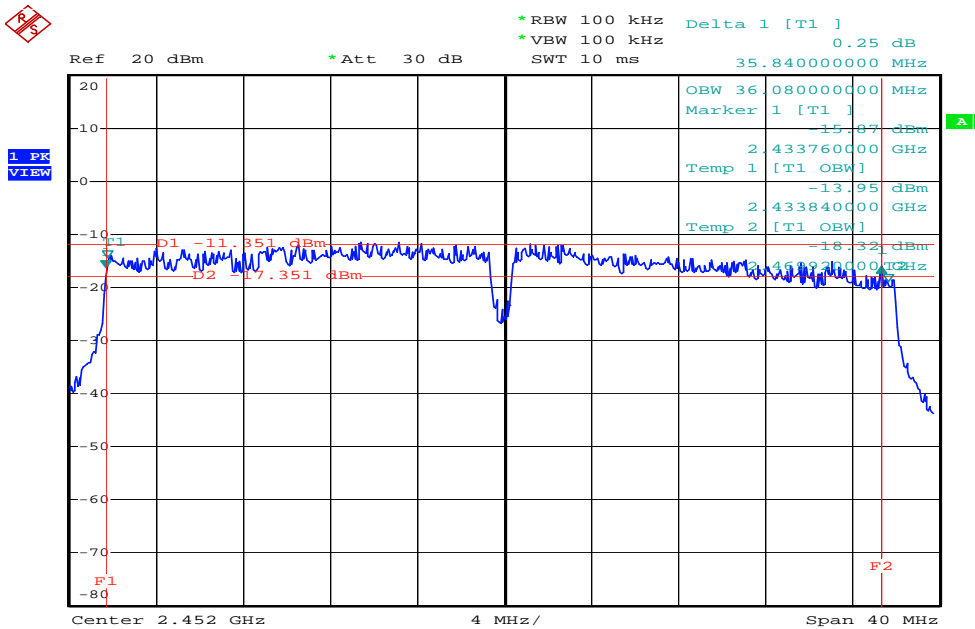

Date: 3.APR.2006 19:43:02

4.5. Radiated Emissions Measurement

4.5.1. Limit

20dBc in any 100 kHz bandwidth outside the operating frequency band. In case the emission fall within the restricted band specified on 15.205(a), then the 15.209(a) limit in the table below has to be followed.

Frequencies (MHz)	Field Strength (microrvolts/meter)	Measurement Distance (meters)
0.009~0.490	2400/F(KHz)	300
0.490~1.705	24000/F(KHz)	30
1.705~30.0	30	30
30~88	100	3
88~216	150	3
216~960	200	3
Above 960	500	3

4.5.2. Measuring Instruments and Setting

Please refer to section 5 in this report. The following table is the setting of spectrum analyzer and receiver.

Spectrum Parameter	Setting
Attenuation	Auto
Start Frequency	1000 MHz
Stop Frequency	10th carrier harmonic
RB / VB (emission in restricted band)	1MHz / 1MHz for Peak, 1 MHz / 10Hz for Average
RB / VB (other emission)	100KHz / 100KHz for peak

Receiver Parameter	Setting
Attenuation	Auto
Start ~ Stop Frequency	9kHz~150kHz / RB 200Hz for QP
Start ~ Stop Frequency	150kHz~30MHz / RB 9kHz for QP
Start ~ Stop Frequency	30MHz~1000MHz / RB 120kHz for QP

4.5.3. Test Procedures

1. Configure the EUT according to ANSI C63.4. The EUT was placed on the top of the turntable 0.8 meter above ground. The phase center of the receiving antenna mounted on the top of a height-variable antenna tower was placed 3 meters far away from the turntable.
2. Power on the EUT and all the supporting units. The turntable was rotated by 360 degrees to determine the position of the highest radiation.
3. The height of the broadband receiving antenna was varied between one meter and four meters above ground to find the maximum emissions field strength of both horizontal and vertical polarization.
4. For each suspected emissions, the antenna tower was scan (from 1 M to 4 M) and then the turntable was rotated (from 0 degree to 360 degrees) to find the maximum reading.
5. Set the test-receiver system to Peak or CISPR quasi-peak Detect Function with specified bandwidth under Maximum Hold Mode.
6. For emissions above 1GHz, use 1MHz VBW and RBW for peak reading. Then 1MHz RBW and 10Hz VBW for average reading in spectrum analyzer.
7. When the radiated emissions limits are expressed in terms of the average value of the emissions, and pulsed operation is employed, the measurement field strength shall be determined by averaging over one complete pulse train, including blanking intervals, as long as the pulse train does not exceed 0.1 seconds. As an alternative (provided the transmitter operates for longer than 0.1 seconds) or in cases where the pulse train exceeds 0.1 seconds, the measured field strength shall be determined from the average absolute voltage during a 0.1 second interval during which the field strength is at its maximum value.
8. If the emissions level of the EUT in peak mode was 3 dB lower than the average limit specified, then testing will be stopped and peak values of EUT will be reported, otherwise, the emissions which do not have 3 dB margin will be repeated one by one using the quasi-peak method for below 1GHz.
9. For testing above 1GHz, the emissions level of the EUT in peak mode was lower than average limit (that means the emissions level in peak mode also complies with the limit in average mode), then testing will be stopped and peak values of EUT will be reported, otherwise, the emissions will be measured in average mode again and reported.
10. In case the emission is lower than 30MHz, loop antenna has to be used for measurement and the recorded data should be QP measured by receiver. High – Low scan is not required in this case.

4.5.4. Test Setup Layout

For radiated emissions below 30MHz

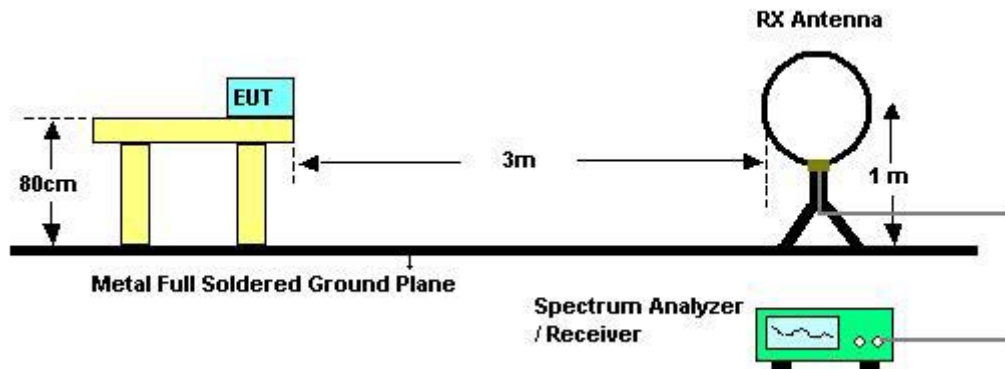

For radiated emissions above 30MHz

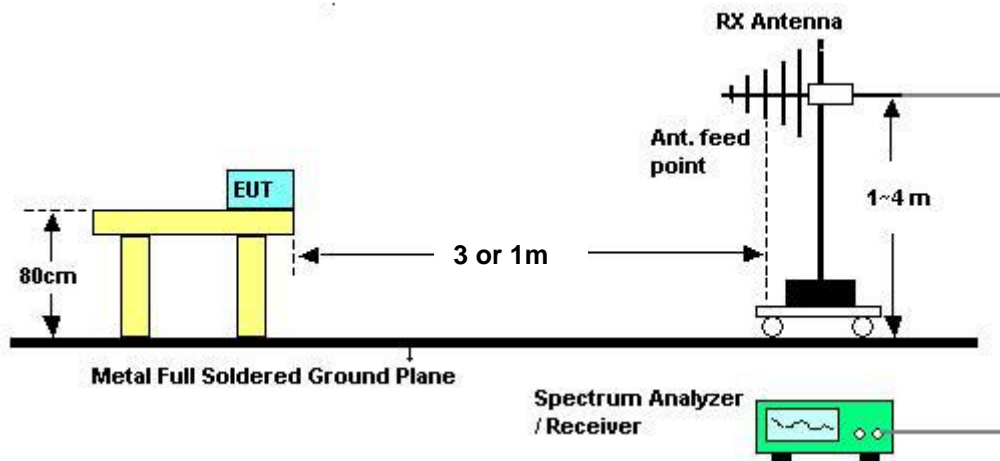

Above 10 GHz shall be extrapolated to the specified distance using an extrapolation factor of 20 dB/decade from 3m to 1m.

Distance extrapolation factor = $20 \log(\text{specific distance [3m]} / \text{test distance [1m]})$ (dB);

Limit line = specific limits (dBuV) + distance extrapolation factor [9.54 dB].

4.5.5. Test Deviation

There is no deviation with the original standard.

4.5.6. EUT Operation during Test

The EUT was programmed to be in continuously transmitting mode.

**4.5.7. Results of Radiated Emissions (9kHz~30MHz)**

Temperature	20°C	Humidity	70%
Test Engineer	Leo Hung	Configurations	draft 11n Channel 6

Freq. (MHz)	Level (dBuV)	Over Limit (dB)	Limit Line (dBuV)	Remark
-	-	-	-	See Note

Note:

The amplitude of spurious emissions which are attenuated by more than 20 dB below the permissible value has no need to be reported.

Distance extrapolation factor = $40 \log(\text{specific distance} / \text{test distance})$ (dB);

Limit line = specific limits (dBuV) + distance extrapolation factor.

4.5.8. Results of Radiated Emissions (30MHz~1GHz)

Temperature	20°C	Humidity	70%
Test Engineer	Leo Hung	Configurations	draft 11n Channel 6 / Adapter 1

Vertical

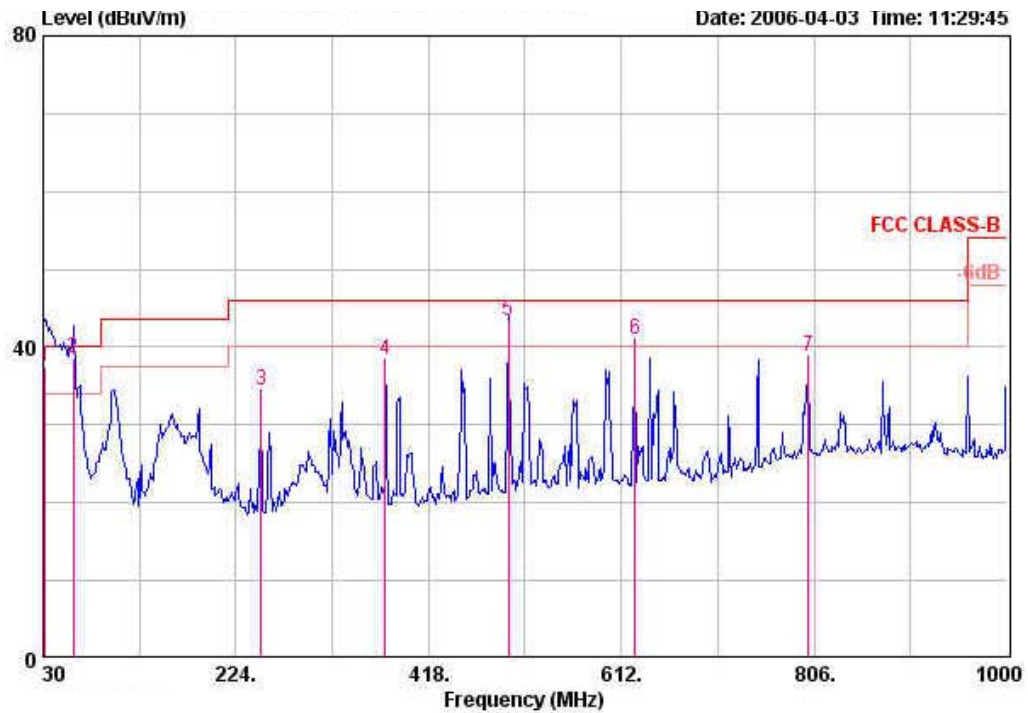

	Freq	Level	Over Limit	Limit Line	Read Level	Preamp Factor	Cable Loss	Antenna Factor	Remark	Ant Pos	Table Pos
	MHz	dBuV/m	dB	dBuV/m	dBuV	dB	dB	dB/m		cm	deg
1	31.940	37.54	-2.46	40.00	47.80	28.60	1.12	17.22	QP	100	172
2	60.070	38.52	-1.48	40.00	58.00	28.50	1.90	7.12	QP	100	180
3	249.220	34.48	-11.52	46.00	46.37	27.80	3.59	12.32	Peak	---	---
4	374.350	38.42	-7.58	46.00	46.75	28.15	4.30	15.52	Peak	---	---
5	498.510	43.35	-2.65	46.00	49.80	28.79	4.98	17.35	QP	100	270
6	625.580	40.88	-5.12	46.00	46.13	28.80	5.90	17.64	Peak	---	---
7	800.180	38.89	-7.11	46.00	39.07	27.70	6.40	21.12	Peak	---	---



Temperature	20°C	Humidity	70%
Test Engineer	Leo Hung	Configurations	draft 11n Channel 6 / Adapter 1

Horizontal

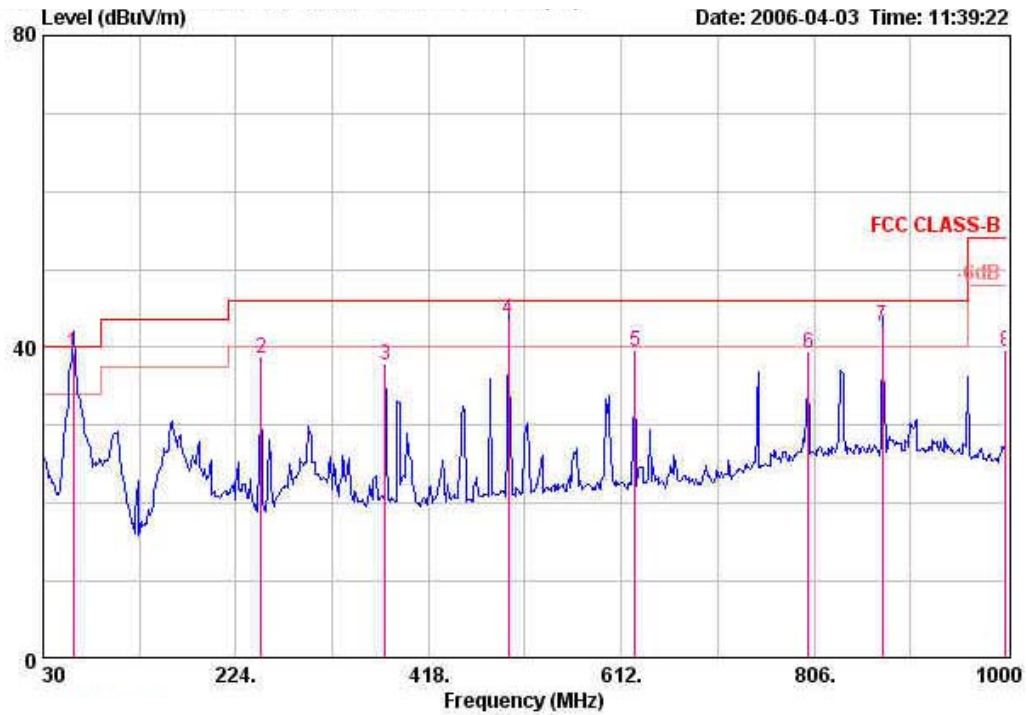

	Freq	Level	Over Limit	Limit Line	Read Level	Preamp Factor	Cable Loss	Antenna Factor	Remark	Ant Pos	Table Pos
	MHz	dBuV/m	dB	dBuV/m	dBuV	dB	dB	dB/m		cm	deg
1	60.070	39.32	-0.68	40.00	58.80	28.50	1.90	7.12	QP	400	180
2	249.220	38.55	-7.45	46.00	50.44	27.80	3.59	12.32	Peak	---	---
3	374.350	37.68	-8.32	46.00	46.01	28.15	4.30	15.52	Peak	---	---
4	498.510	43.65	-2.35	46.00	50.10	28.79	4.98	17.35	QP	137	262
5	625.580	39.49	-6.51	46.00	44.75	28.80	5.90	17.64	Peak	---	---
6	800.180	39.15	-6.85	46.00	39.33	27.70	6.40	21.12	Peak	---	---
7	874.870	42.71	-3.29	46.00	42.77	27.65	6.65	20.94	QP	118	316
8	999.030	39.55	-14.45	54.00	40.40	27.50	7.00	19.65	Peak	---	---



Temperature	20°C	Humidity	70%
Test Engineer	Leo Hung	Configurations	draft 11n Channel 6 / Adapter 2

Vertical

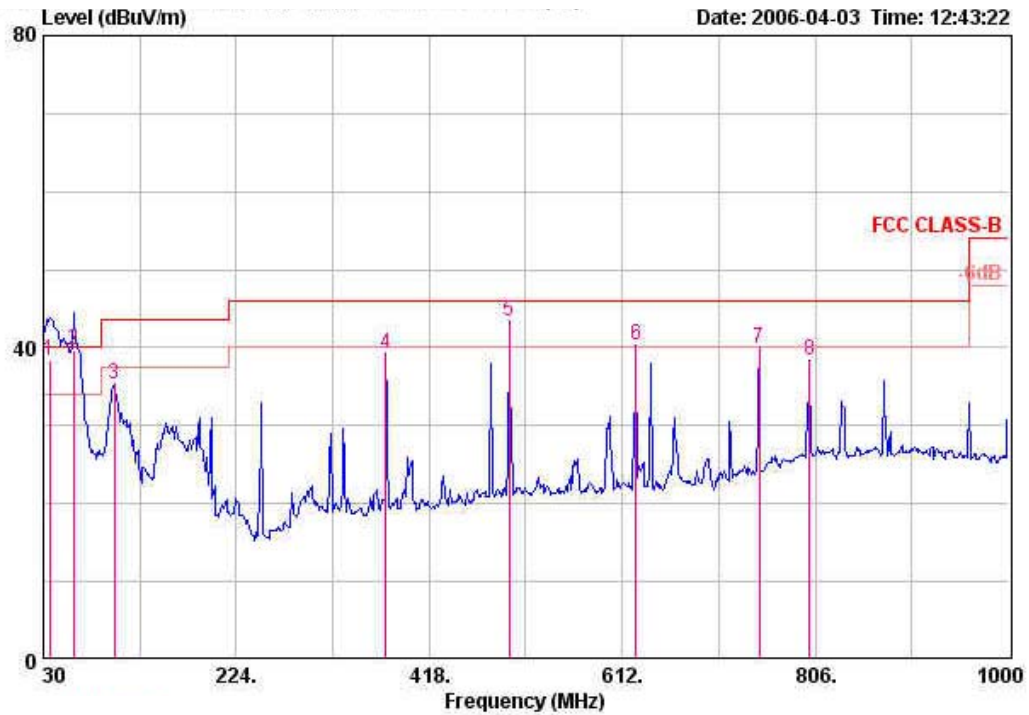

	Freq	Level	Over	Limit	Read	Preamp	Cable	Antenna	Ant	Table
	MHz	dBuV/m	dB	dBuV/m	Level	Factor	Loss	Factor	Pos	Pos
					dBuV	dB	dB	dB/m	cm	deg
1	36.790	38.45	-1.55	40.00	50.50	28.60	1.34	15.21	100	0
2	60.070	39.62	-0.38	40.00	59.10	28.50	1.90	7.12	100	90
3	101.780	35.30	-8.20	43.50	50.36	28.39	2.32	11.01	---	---
4	374.350	39.17	-6.83	46.00	47.51	28.15	4.30	15.52	---	---
5	498.510	43.32	-2.68	46.00	49.77	28.79	4.98	17.35	100	200
6	625.580	40.33	-5.67	46.00	45.58	28.80	5.90	17.64	---	---
7	749.740	39.99	-6.01	46.00	42.27	28.00	6.10	19.62	---	---
8	800.180	38.28	-7.72	46.00	38.46	27.70	6.40	21.12	---	---



Temperature	20°C	Humidity	70%
Test Engineer	Leo Hung	Configurations	draft 11n Channel 6 / Adapter 2

Horizontal

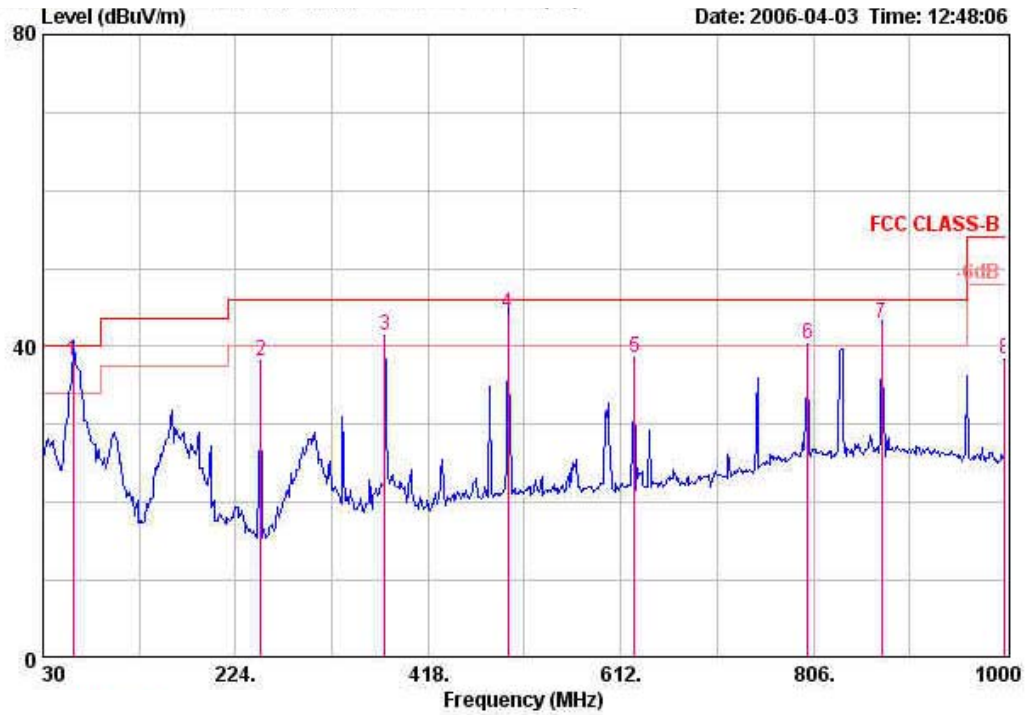

	Freq	Level	Over	Limit	Read	Preamp	CableAntenna		Ant	Table
	MHz	dBuV/m	Limit	Line	Level	Factor	Loss	Factor	Pos	Pos
			dB	dBuV/m	dBuV	dB	dB	dB/m	cm	deg
1	60.070	38.12	-1.88	40.00	57.60	28.50	1.90	7.12	QP	400 180
2	249.220	38.04	-7.96	46.00	49.93	27.80	3.59	12.32	Peak	--- ---
3	374.350	41.40	-4.60	46.00	49.73	28.15	4.30	15.52	Peak	--- ---
4	498.510	44.25	-1.75	46.00	50.70	28.79	4.98	17.35	QP	178 285
5	625.580	38.68	-7.32	46.00	43.94	28.80	5.90	17.64	Peak	--- ---
6	800.180	40.27	-5.73	46.00	40.45	27.70	6.40	21.12	Peak	--- ---
7	874.870	43.04	-2.96	46.00	43.10	27.65	6.65	20.94	QP	120 290
8	999.030	38.46	-15.54	54.00	39.31	27.50	7.00	19.65	Peak	--- ---

Note:

The amplitude of spurious emissions which are attenuated by more than 20 dB below the permissible value has no need to be reported.

Emission level (dBuV/m) = 20 log Emission level (uV/m).

Corrected Reading: Antenna Factor + Cable Loss + Read Level - Preamp Factor = Level.



4.5.9. Results for Radiated Emissions (1GHz~10th Harmonic)

Temperature	20°C	Humidity	70%
Test Engineer	Leo Hung	Configurations	draft 11n MCS8 20MHz Channel 1 Ant. A + Ant. B

Vertical

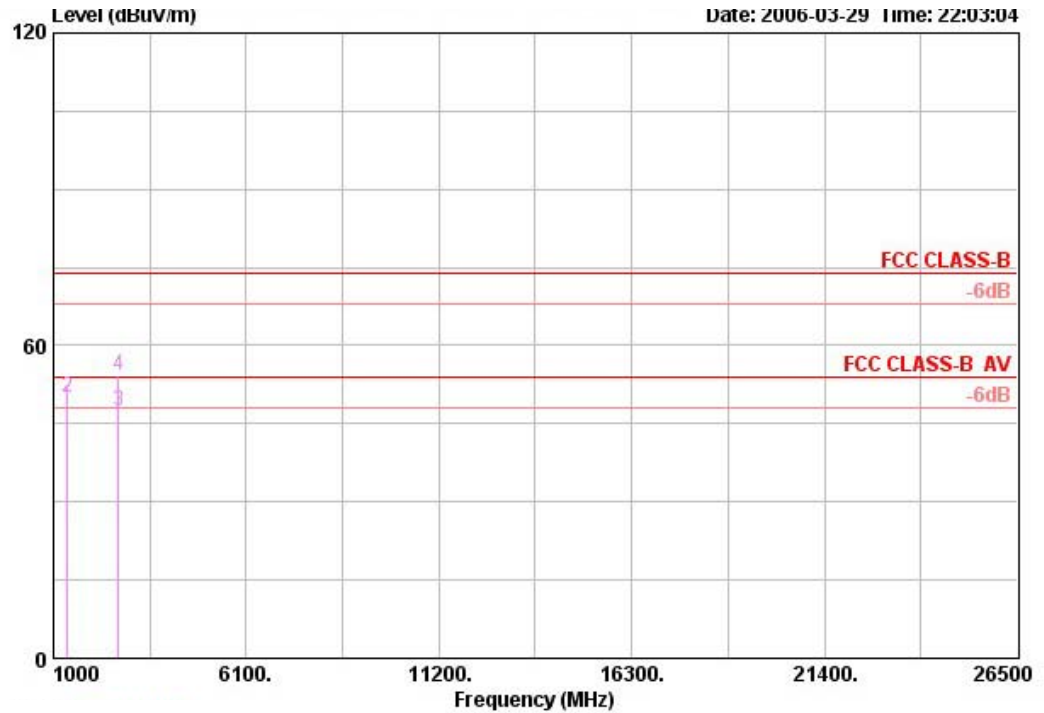

	Freq	Level	Over	Limit	Read	Antenna	Cable	Preamp	Remark	Ant	Table
	MHz	dBuV/m	dB	dBuV/m	dBuV	dB/m	dB	dB		cm	deg
1 *	1374.980	48.47	-5.53	54.00	52.73	24.96	5.37	34.59	AVERAGE	---	---
2	1374.980	49.99	-24.01	74.00	54.25	24.96	5.37	34.59	PEAK	---	---
3	2720.000	47.36	-6.64	54.00	44.62	29.65	8.24	35.15	AVERAGE	---	---
4	2720.000	54.24	-19.76	74.00	51.50	29.65	8.24	35.15	PEAK	---	---



Temperature	20°C	Humidity	70%
Test Engineer	Leo Hung	Configurations	draft 11n MCS8 20MHz Channel 1 Ant. A + Ant. B

Horizontal

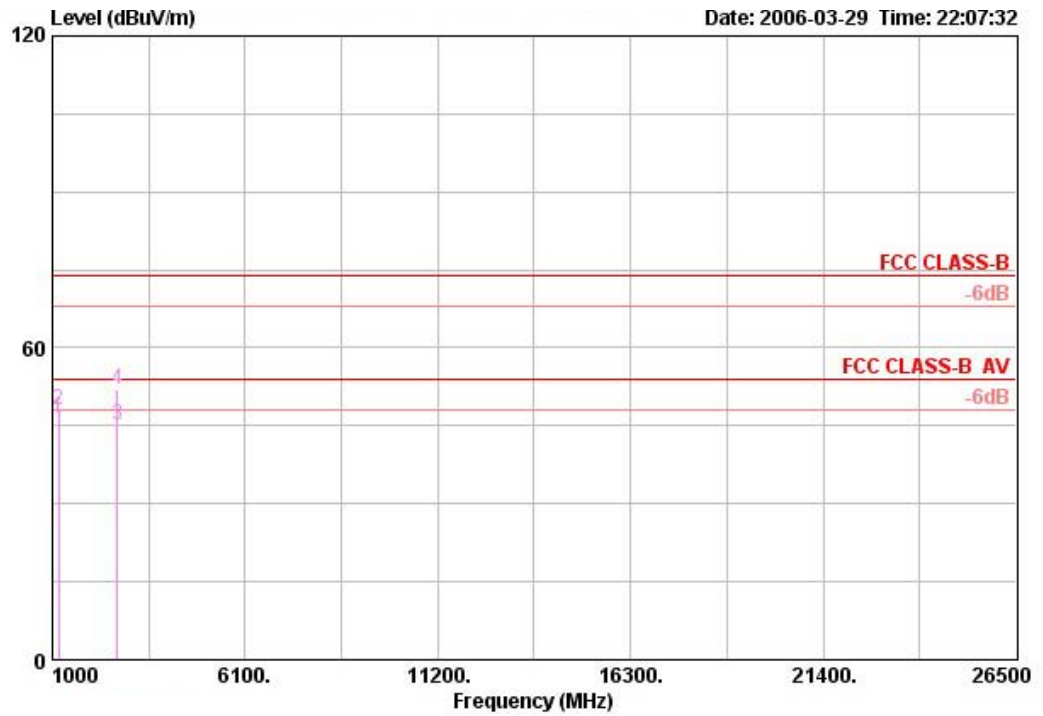

	Freq	Level	Over Limit	Limit Line	ReadAntenna Level	Antenna Factor	Cable Loss	Preamp Factor	Remark	Ant Pos	Table Pos
	MHz	dBuV/m	dB	dBuV/m	dBuV	dB/m	dB	dB		cm	deg
1	1166.720	46.54	-7.46	54.00	51.72	24.38	4.88	34.44	AVERAGE	---	---
2	1166.720	47.99	-26.01	74.00	53.16	24.38	4.88	34.44	PEAK	---	---
3	2720.000	45.10	-8.90	54.00	42.36	29.65	8.24	35.15	AVERAGE	---	---
4	2720.000	52.06	-21.94	74.00	49.32	29.65	8.24	35.15	PEAK	---	---



Temperature	20°C	Humidity	70%
Test Engineer	Leo Hung	Configurations	draft 11n MCS8 20MHz Channel 6 Ant. A + Ant. B

Vertical

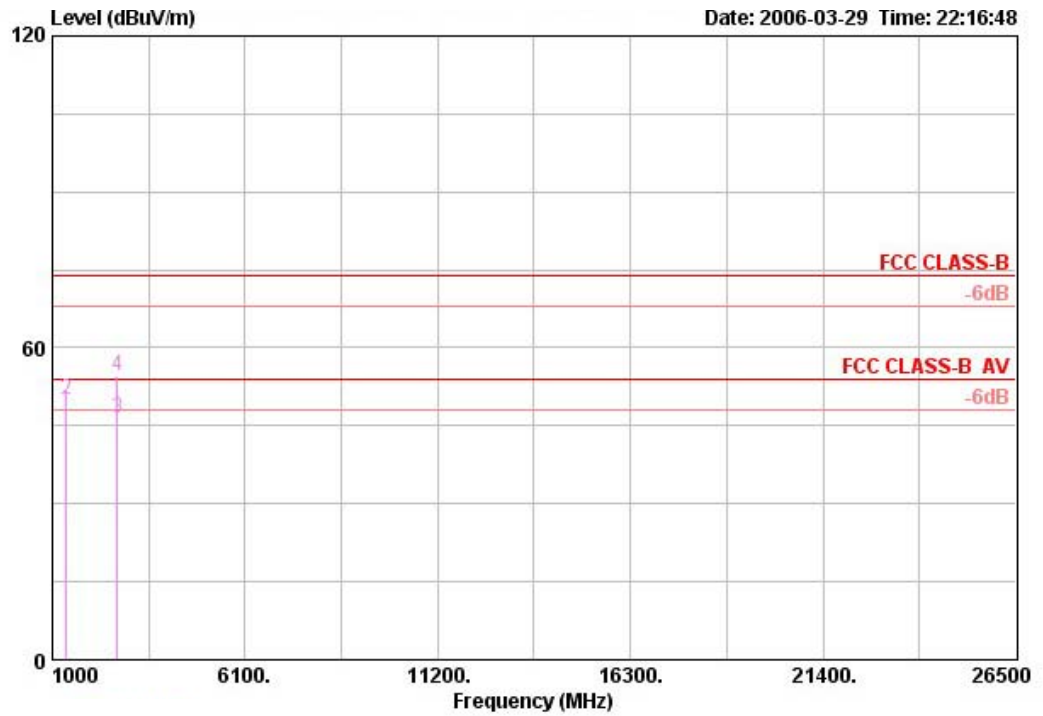

	Freq	Level	Over Limit	Limit Line	ReadAntenna Level	Antenna Factor	Cable Loss	Preamp Factor	Remark	Ant Pos	Table Pos
	MHz	dBuV/m	dB	dBuV/m	dBuV	dB/m	dB	dB		cm	deg
1	1375.000	47.97	-6.03	54.00	52.23	24.96	5.37	34.59	AVERAGE	---	---
2	1375.000	49.97	-24.03	74.00	54.23	24.96	5.37	34.59	PEAK	---	---
3	2720.000	46.46	-7.54	54.00	43.72	29.65	8.24	35.15	AVERAGE	---	---
4	2720.000	54.51	-19.49	74.00	51.76	29.65	8.24	35.15	PEAK	---	---



Temperature	20°C	Humidity	70%
Test Engineer	Leo Hung	Configurations	draft 11n MCS8 20MHz Channel 6 Ant. A + Ant. B

Horizontal

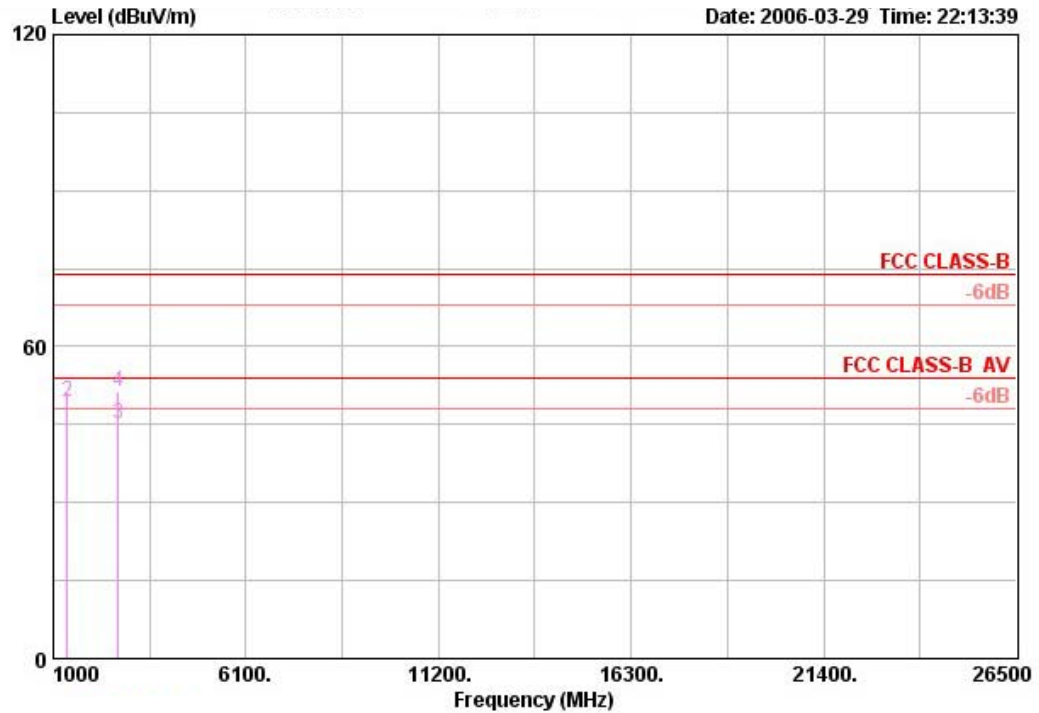

	Freq	Level	Over Limit	Limit Line	ReadAntenna Level	Antenna Factor	Cable Loss	Preamp Factor	Remark	Ant Pos	Table Pos
	MHz	dBuV/m	dB	dBuV/m	dBuV	dB/m	dB	dB		cm	deg
1	1375.040	47.52	-6.48	54.00	51.78	24.96	5.37	34.59	AVERAGE	---	---
2	1375.040	49.38	-24.62	74.00	53.63	24.96	5.37	34.59	PEAK	---	---
3	2720.000	45.19	-8.81	54.00	42.44	29.65	8.24	35.15	AVERAGE	---	---
4	2720.000	51.39	-22.61	74.00	48.65	29.65	8.24	35.15	PEAK	---	---



Temperature	20°C	Humidity	70%
Test Engineer	Leo Hung	Configurations	draft 11n MCS8 20MHz Channel 11 Ant. A + Ant. B

Vertical

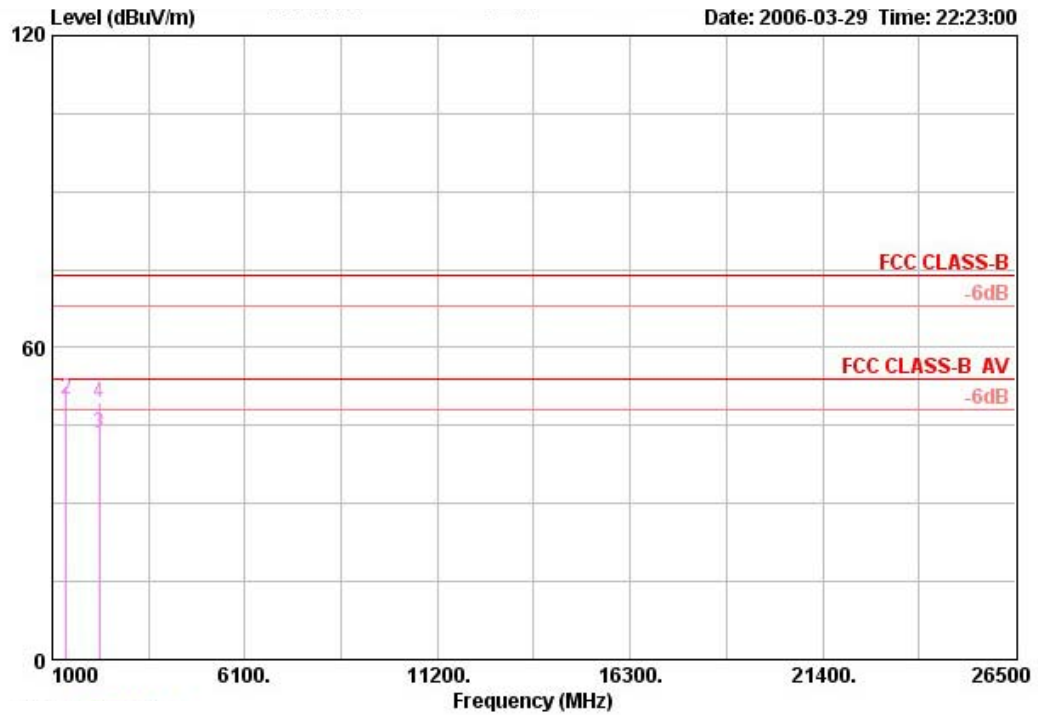

	Freq	Level	Over Limit	Limit Line	ReadAntenna Level	Antenna Factor	Cable Loss	Preamp Factor	Remark	Ant Pos	Table Pos
	MHz	dBuV/m	dB	dBuV/m	dBuV	dB/m	dB	dB		cm	deg
1 *	1375.020	48.41	-5.59	54.00	52.67	24.96	5.37	34.59	AVERAGE	---	---
2	1375.020	50.09	-23.91	74.00	54.34	24.96	5.37	34.59	PEAK	---	---
3	2240.000	43.42	-10.58	54.00	42.77	28.69	6.99	35.02	AVERAGE	---	---
4	2240.000	49.31	-24.69	74.00	48.65	28.69	6.99	35.02	PEAK	---	---



Temperature	20°C	Humidity	70%
Test Engineer	Leo Hung	Configurations	draft 11n MCS8 20MHz Channel 11 Ant. A + Ant. B

Horizontal

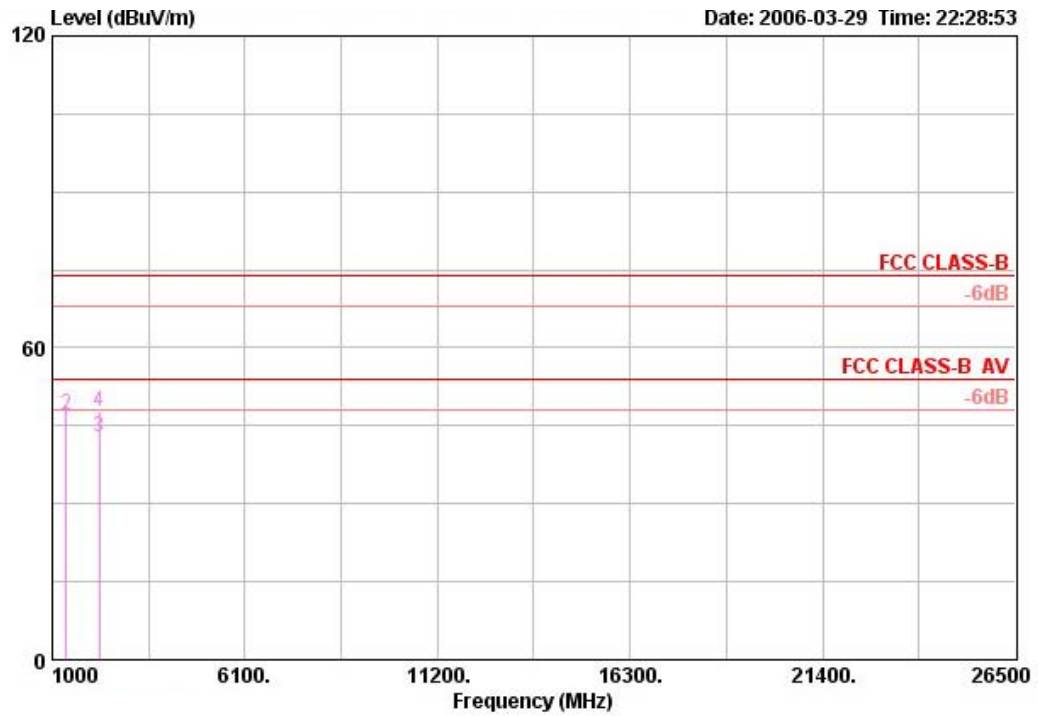

	Freq	Level	Over Limit	Limit Line	ReadAntenna Level	Antenna Factor	Cable Loss	Preamp Factor	Remark	Ant Pos	Table Pos
	MHz	dBuV/m	dB	dBuV/m	dBuV	dB/m	dB	dB		cm	deg
1	1374.900	44.78	-9.22	54.00	49.03	24.96	5.37	34.59	AVERAGE	---	---
2	1374.900	47.15	-26.85	74.00	51.41	24.96	5.37	34.59	PEAK	---	---
3	2250.000	42.83	-11.17	54.00	42.16	28.71	6.99	35.02	AVERAGE	---	---
4	2250.000	47.63	-26.37	74.00	46.96	28.71	6.99	35.02	PEAK	---	---



Temperature	20°C	Humidity	70%
Test Engineer	Leo Hung	Configurations	draft 11n MCS8 40MHz Channel 3 Ant. A + Ant. B

Vertical

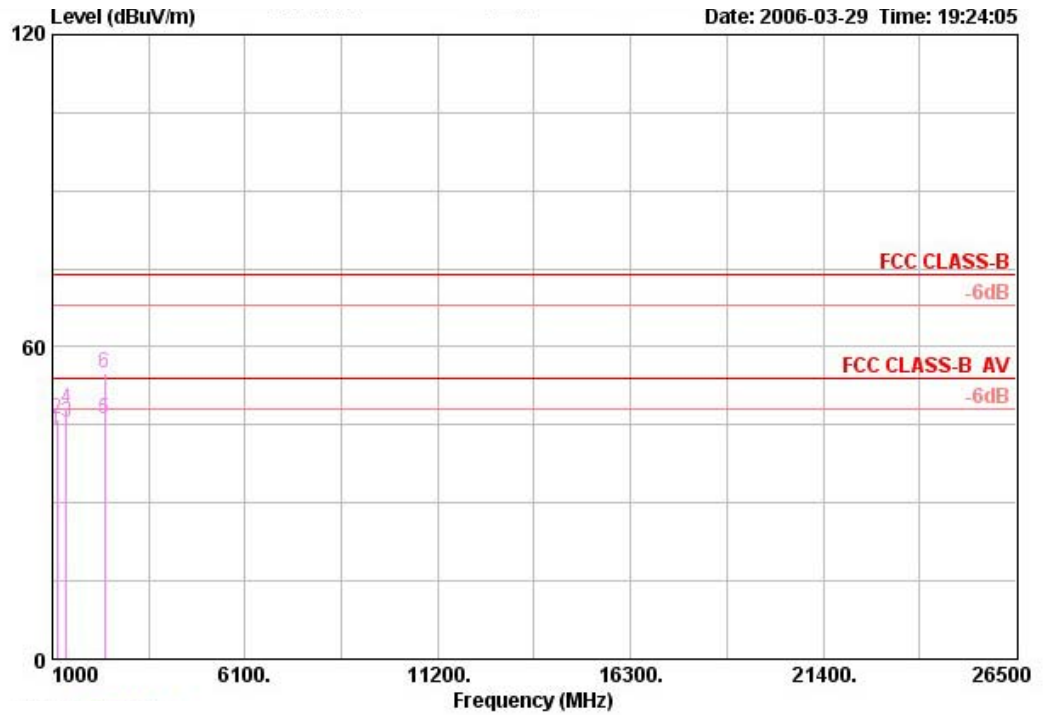

	Freq	Level	Over Limit	Limit Line	ReadAntenna Level	Antenna Factor	Cable Loss	Preamp Factor	Remark	Ant Pos	Table Pos
	MHz	dBuV/m	dB	dBuV/m	dBuV	dB/m	dB	dB		cm	deg
1	1119.960	43.89	-10.11	54.00	49.26	24.24	4.80	34.41	AVERAGE	---	---
2	1119.960	46.18	-27.82	74.00	51.55	24.24	4.80	34.41	PEAK	---	---
3	1374.960	45.44	-8.56	54.00	49.69	24.96	5.37	34.59	AVERAGE	---	---
4	1374.960	48.15	-25.85	74.00	52.41	24.96	5.37	34.59	PEAK	---	---
5	2373.200	46.21	-7.79	54.00	45.12	28.86	7.34	35.10	AVERAGE	---	---
6	2373.200	55.08	-18.92	74.00	53.99	28.86	7.34	35.10	PEAK	---	---



Temperature	20°C	Humidity	70%
Test Engineer	Leo Hung	Configurations	draft 11n MCS8 40MHz Channel 3 Ant. A + Ant. B

Horizontal

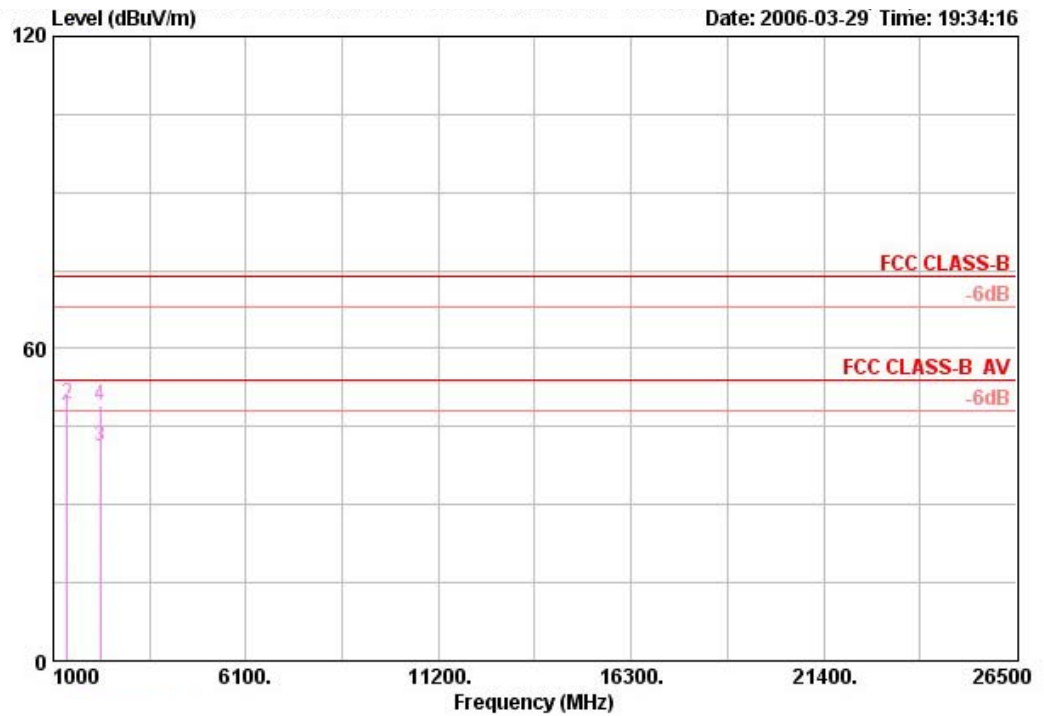

	Freq	Level	Over Limit	Limit Line	ReadAntenna Level	Antenna Factor	Cable Loss	Preamp Factor	Remark	Ant Pos	Table Pos
	MHz	dBuV/m	dB	dBuV/m	dBuV	dB/m	dB	dB		cm	deg
1	1375.000	47.25	-6.75	54.00	51.50	24.96	5.37	34.59	AVERAGE	---	---
2	1375.000	49.23	-24.77	74.00	53.49	24.96	5.37	34.59	PEAK	---	---
3	2240.000	41.21	-12.79	54.00	40.56	28.69	6.99	35.02	AVERAGE	---	---
4	2240.000	48.90	-25.10	74.00	48.24	28.69	6.99	35.02	PEAK	---	---



Temperature	20°C	Humidity	70%
Test Engineer	Leo Hung	Configurations	draft 11n MCS8 40MHz Channel 6 Ant. A + Ant. B

Vertical

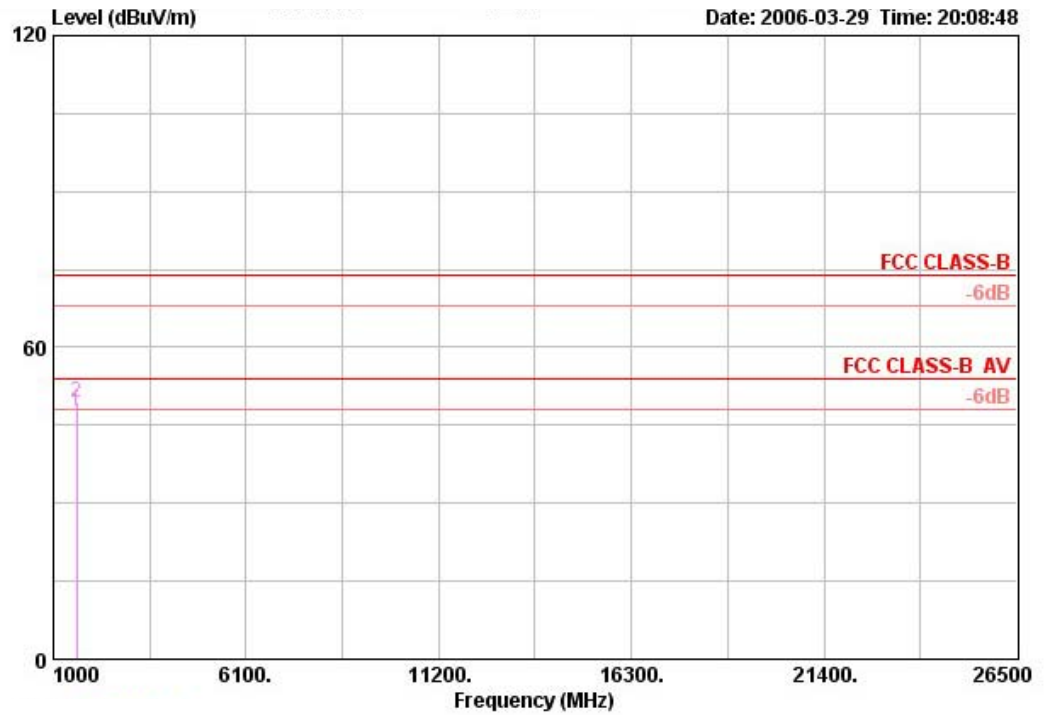

	Freq	Level	Over Limit	Limit Line	ReadAntenna Level	Antenna Factor	Cable Loss	Preamp Factor	Remark	Ant Pos	Table Pos
	MHz	dBuV/m	dB	dBuV/m	dBuV	dB/m	dB	dB		cm	deg
1	1625.000	47.81	-6.19	54.00	50.61	26.13	5.81	34.73	AVERAGE	---	---
2	1625.000	49.43	-24.57	74.00	52.22	26.13	5.81	34.73	PEAK	---	---



Temperature	20°C	Humidity	70%
Test Engineer	Leo Hung	Configurations	draft 11n MCS8 40MHz Channel 6 Ant. A + Ant. B

Horizontal

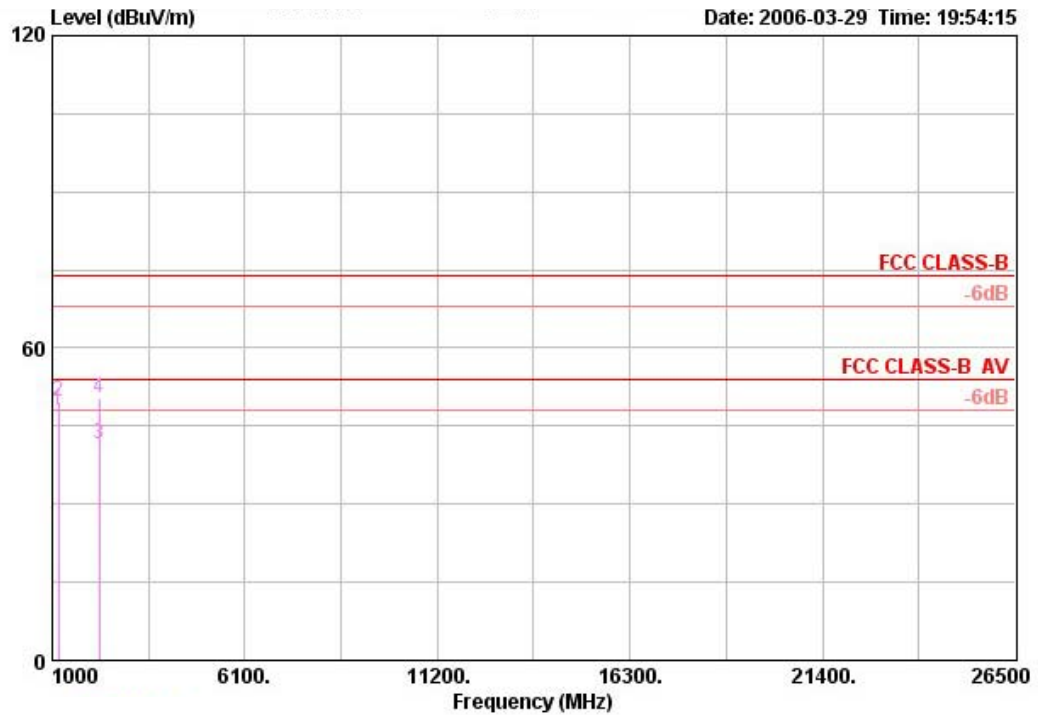

	Freq	Level	Over Limit	Limit Line	ReadAntenna Level	Antenna Factor	Cable Loss	Preamp Factor	Remark	Ant Pos	Table Pos
	MHz	dBuV/m	dB	dBuV/m	dBuV	dB/m	dB	dB		cm	deg
1	1166.700	47.91	-6.09	54.00	53.09	24.38	4.88	34.44	AVERAGE	---	---
2	1166.700	49.57	-24.43	74.00	54.75	24.38	4.88	34.44	PEAK	---	---
3	2240.000	41.37	-12.63	54.00	40.72	28.69	6.99	35.02	AVERAGE	---	---
4	2240.000	50.41	-23.59	74.00	49.76	28.69	6.99	35.02	PEAK	---	---



Temperature	20°C	Humidity	70%
Test Engineer	Leo Hung	Configurations	draft 11n MCS8 40MHz Channel 9 Ant. A + Ant. B

Vertical

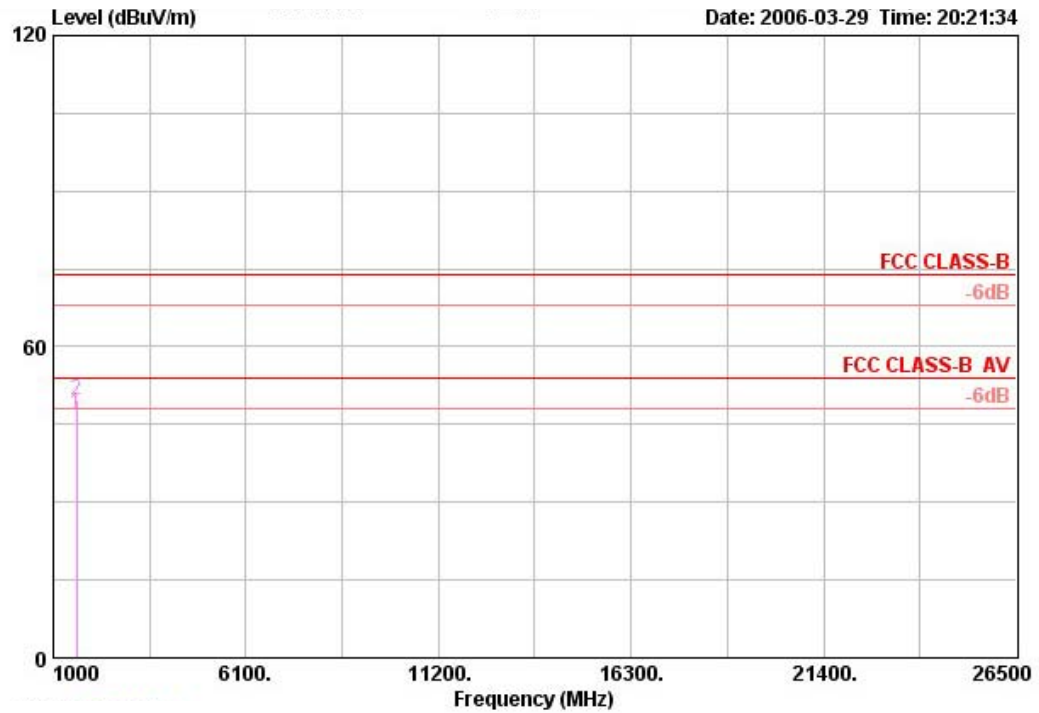

	Freq	Level	Over Limit	Limit Line	ReadAntenna Level	Antenna Factor	Cable Loss	Preamp Factor	Remark	Ant Pos	Table Pos
	MHz	dBuV/m	dB	dBuV/m	dBuV	dB/m	dB	dB		cm	deg
1	1625.000	47.15	-6.85	54.00	49.95	26.13	5.81	34.73	AVERAGE	---	---
2	1625.000	49.55	-24.45	74.00	52.35	26.13	5.81	34.73	PEAK	---	---



Temperature	20°C	Humidity	70%
Test Engineer	Leo Hung	Configurations	draft 11n MCS8 40MHz Channel 9 Ant. A + Ant. B

Horizontal

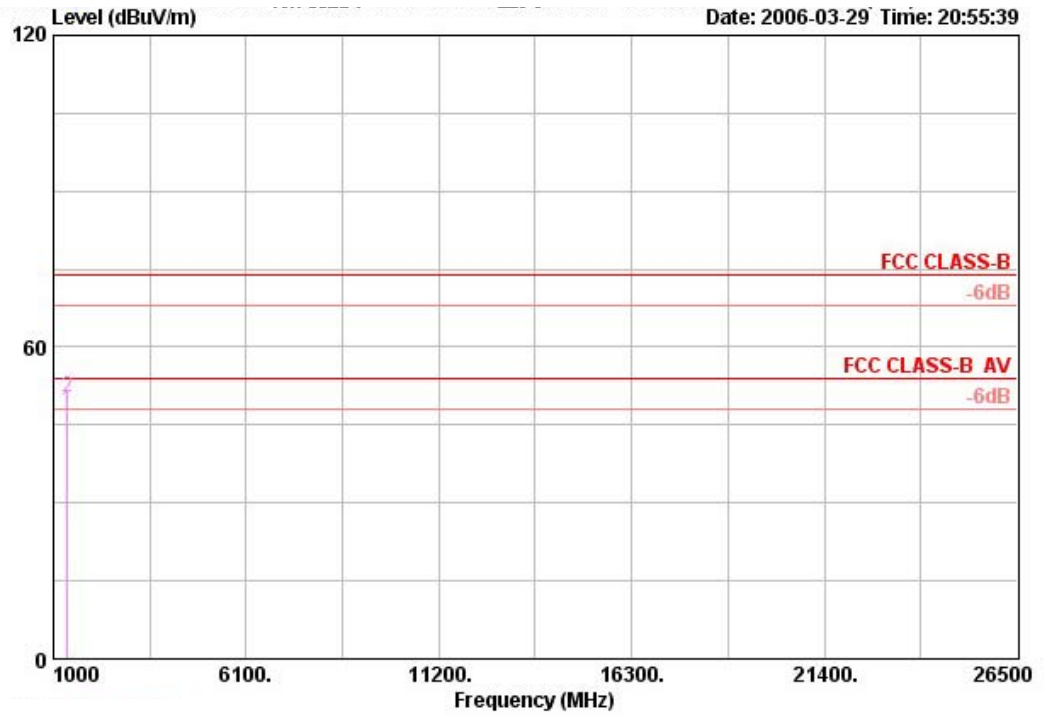

	Freq	Level	Over Limit	Limit Line	ReadAntenna Level	Antenna Factor	Cable Loss	Preamp Factor	Remark	Ant Pos	Table Pos
	MHz	dBuV/m	dB	dBuV/m	dBuV	dB/m	dB	dB		cm	deg
1	1375.040	47.68	-6.32	54.00	51.94	24.96	5.37	34.59	AVERAGE	---	---
2	1375.040	50.30	-23.70	74.00	54.56	24.96	5.37	34.59	PEAK	---	---



Temperature	20°C	Humidity	70%
Test Engineer	Leo Hung	Configurations	draft 11n MCS15 20MHz Channel 1 Ant. A + Ant. B

Vertical

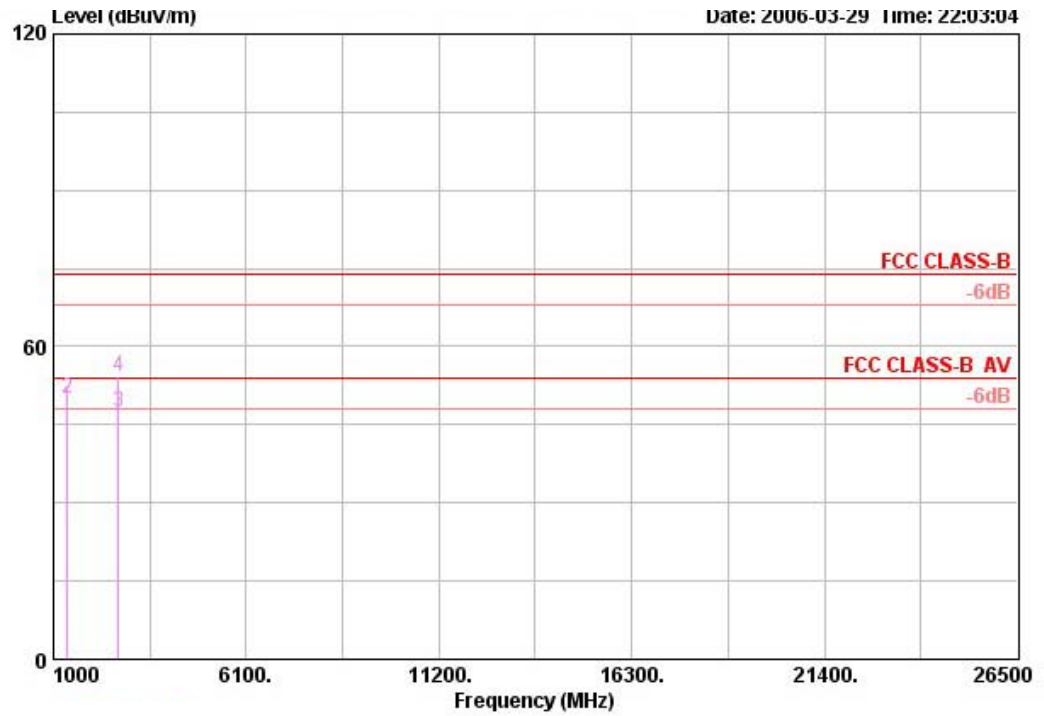

	Freq	Level	Over Limit	Limit Line	ReadAntenna Level	Antenna Factor	Cable Loss	Preamp Factor	Remark	Ant Pos	Table Pos
	MHz	dBuV/m	dB	dBuV/m	dBuV	dB/m	dB	dB		cm	deg
1 *	1374.980	48.47	-5.53	54.00	52.73	24.96	5.37	34.59	AVERAGE	---	---
2	1374.980	49.99	-24.01	74.00	54.25	24.96	5.37	34.59	PEAK	---	---
3	2720.000	47.36	-6.64	54.00	44.62	29.65	8.24	35.15	AVERAGE	---	---
4	2720.000	54.24	-19.76	74.00	51.50	29.65	8.24	35.15	PEAK	---	---



Temperature	20°C	Humidity	70%
Test Engineer	Leo Hung	Configurations	draft 11n MCS15 20MHz Channel 1 Ant. A + Ant. B

Horizontal

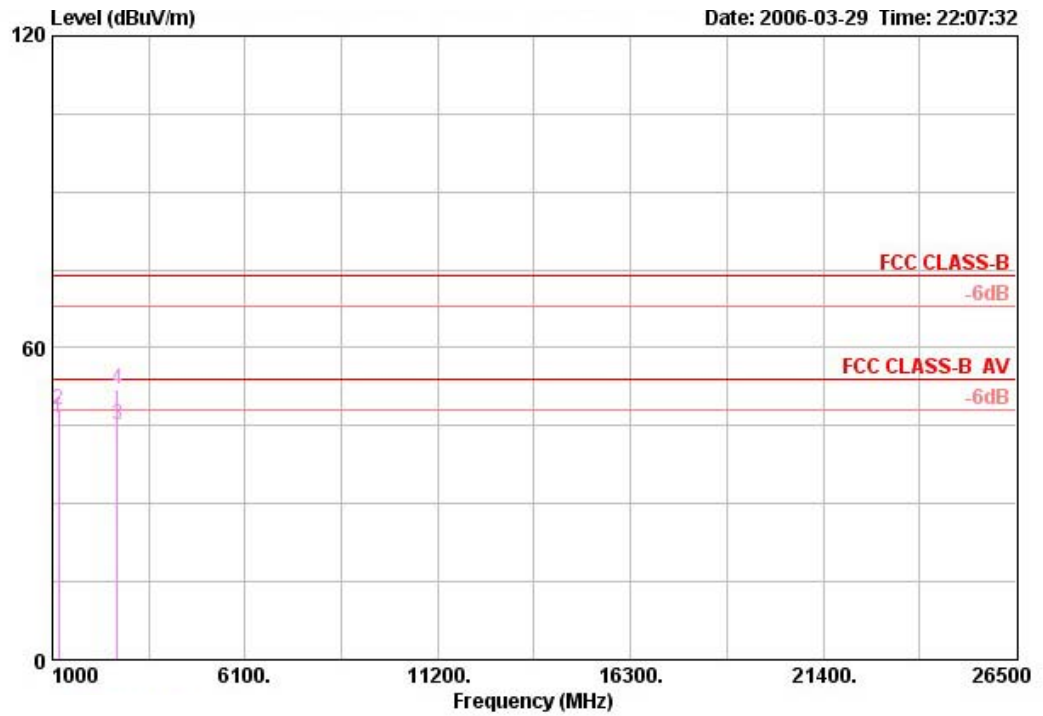

	Freq	Level	Over Limit	Limit Line	ReadAntenna Level	Antenna Factor	Cable Loss	Preamp Factor	Remark	Ant Pos	Table Pos
	MHz	dBuV/m	dB	dBuV/m	dBuV	dB/m	dB	dB		cm	deg
1	1166.720	46.54	-7.46	54.00	51.72	24.38	4.88	34.44	AVERAGE	---	---
2	1166.720	47.99	-26.01	74.00	53.16	24.38	4.88	34.44	PEAK	---	---
3	2720.000	45.10	-8.90	54.00	42.36	29.65	8.24	35.15	AVERAGE	---	---
4	2720.000	52.06	-21.94	74.00	49.32	29.65	8.24	35.15	PEAK	---	---



Temperature	20°C	Humidity	70%
Test Engineer	Leo Hung	Configurations	draft 11n MCS15 20MHz Channel 6 Ant. A + Ant. B

Vertical

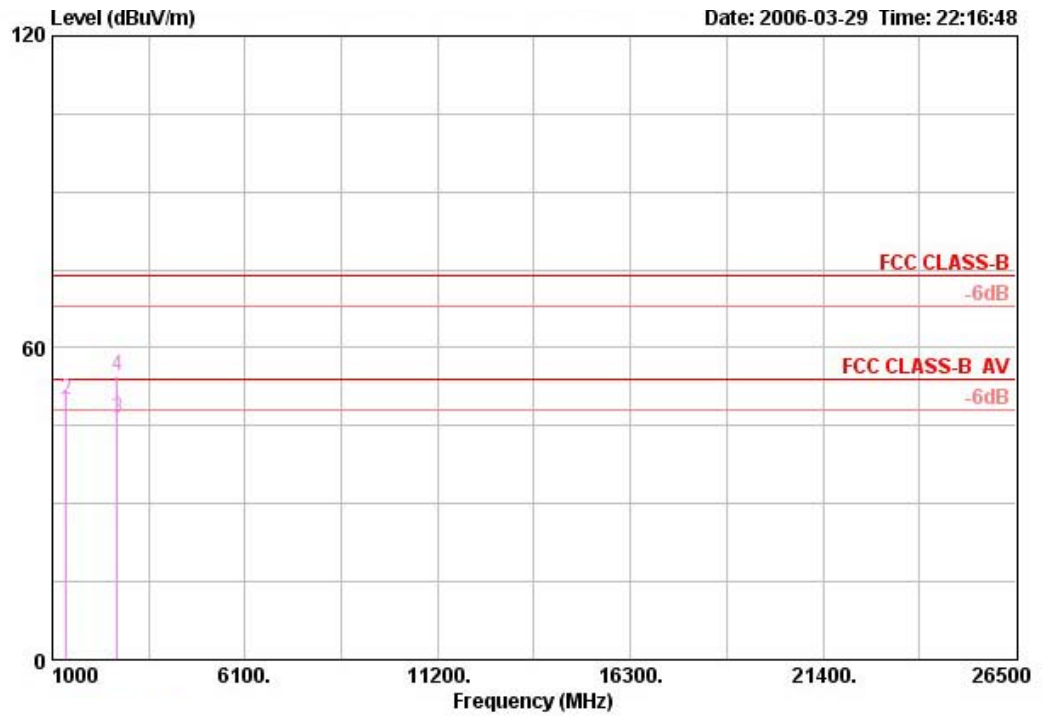

	Freq	Level	Over Limit	Limit Line	ReadAntenna Level	Antenna Factor	Cable Loss	Preamp Factor	Remark	Ant Pos	Table Pos
	MHz	dBuV/m	dB	dBuV/m	dBuV	dB/m	dB	dB		cm	deg
1	1375.000	47.97	-6.03	54.00	52.23	24.96	5.37	34.59	AVERAGE	---	---
2	1375.000	49.97	-24.03	74.00	54.23	24.96	5.37	34.59	PEAK	---	---
3	2720.000	46.46	-7.54	54.00	43.72	29.65	8.24	35.15	AVERAGE	---	---
4	2720.000	54.51	-19.49	74.00	51.76	29.65	8.24	35.15	PEAK	---	---



Temperature	20°C	Humidity	70%
Test Engineer	Leo Hung	Configurations	draft 11n MCS15 20MHz Channel 6 Ant. A + Ant. B

Horizontal

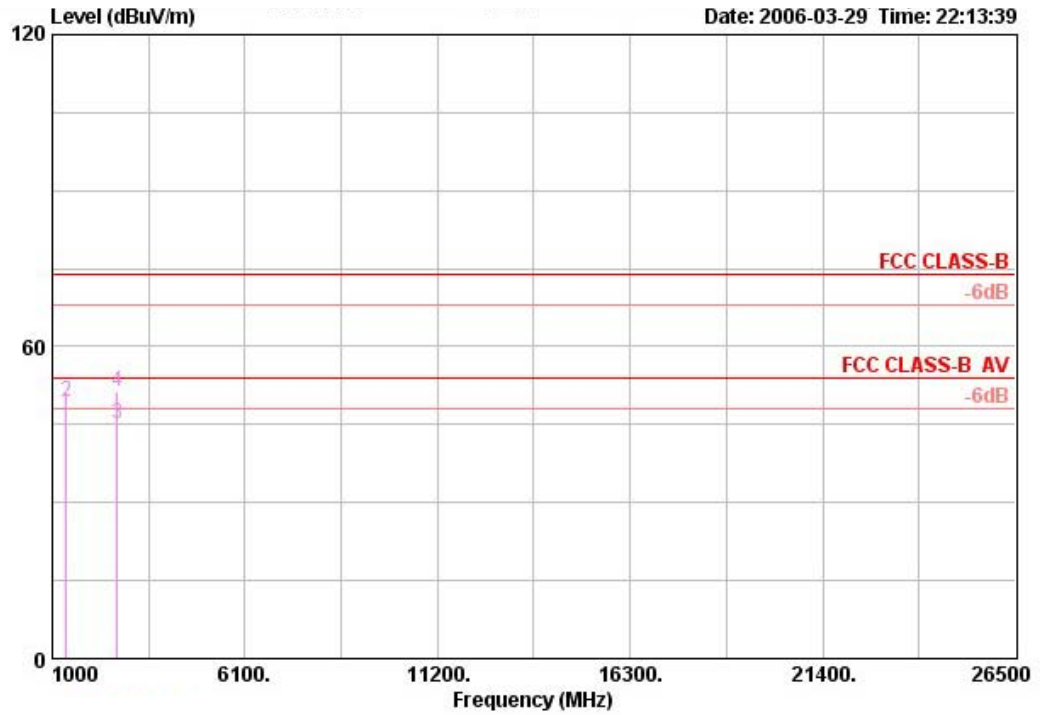

	Freq	Level	Over Limit	Limit Line	ReadAntenna Level	Antenna Factor	Cable Loss	Preamp Factor	Remark	Ant Pos	Table Pos
	MHz	dBuV/m	dB	dBuV/m	dBuV	dB/m	dB	dB		cm	deg
1	1375.040	47.52	-6.48	54.00	51.78	24.96	5.37	34.59	AVERAGE	---	---
2	1375.040	49.38	-24.62	74.00	53.63	24.96	5.37	34.59	PEAK	---	---
3	2720.000	45.19	-8.81	54.00	42.44	29.65	8.24	35.15	AVERAGE	---	---
4	2720.000	51.39	-22.61	74.00	48.65	29.65	8.24	35.15	PEAK	---	---



Temperature	20°C	Humidity	70%
Test Engineer	Leo Hung	Configurations	draft 11n MCS15 20MHz Channel 11 Ant. A + Ant. B

Vertical

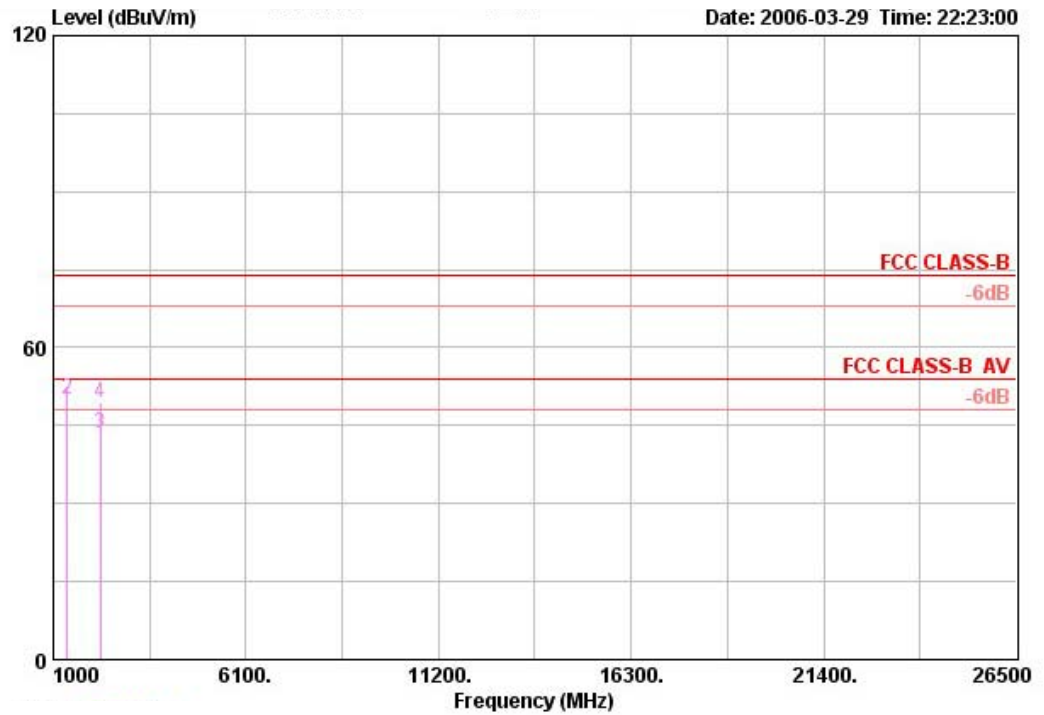

	Freq	Level	Over Limit	Limit Line	ReadAntenna Level	Antenna Factor	Cable Loss	Preamp Factor	Remark	Ant Pos	Table Pos
	MHz	dBUV/m	dB	dBUV/m	dBuV	dB/m	dB	dB		cm	deg
1 *	1375.020	48.41	-5.59	54.00	52.67	24.96	5.37	34.59	AVERAGE	---	---
2	1375.020	50.09	-23.91	74.00	54.34	24.96	5.37	34.59	PEAK	---	---
3	2240.000	43.42	-10.58	54.00	42.77	28.69	6.99	35.02	AVERAGE	---	---
4	2240.000	49.31	-24.69	74.00	48.65	28.69	6.99	35.02	PEAK	---	---



Temperature	20°C	Humidity	70%
Test Engineer	Leo Hung	Configurations	draft 11n MCS15 20MHz Channel 11 Ant. A + Ant. B

Horizontal

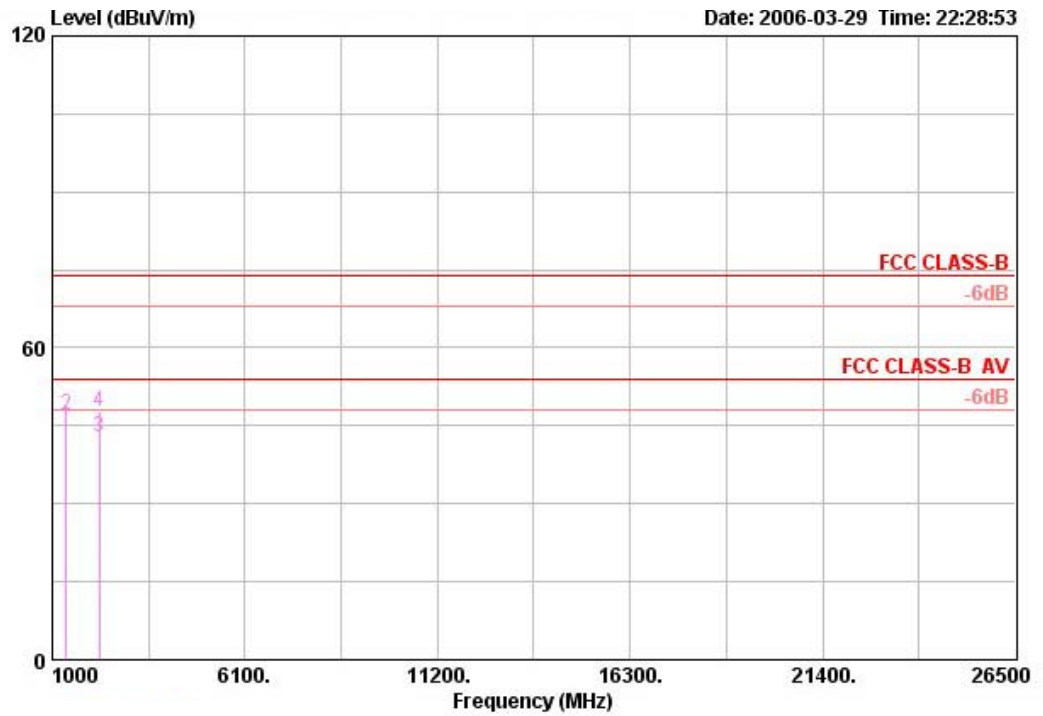

	Freq	Level	Over	Limit	ReadAntenna	Cable	Preamp	Remark	Ant	Table
	MHz	dBuV/m	dB	dBuV/m	dBuV	dB/m	dB	dB	cm	deg
1	1374.900	44.78	-9.22	54.00	49.03	24.96	5.37	34.59 AVERAGE	---	---
2	1374.900	47.15	-26.85	74.00	51.41	24.96	5.37	34.59 PEAK	---	---
3	2250.000	42.83	-11.17	54.00	42.16	28.71	6.99	35.02 AVERAGE	---	---
4	2250.000	47.63	-26.37	74.00	46.96	28.71	6.99	35.02 PEAK	---	---



Temperature	20°C	Humidity	70%
Test Engineer	Leo Hung	Configurations	draft 11n MCS15 40MHz Channel 3 Ant. A + Ant. B

Vertical

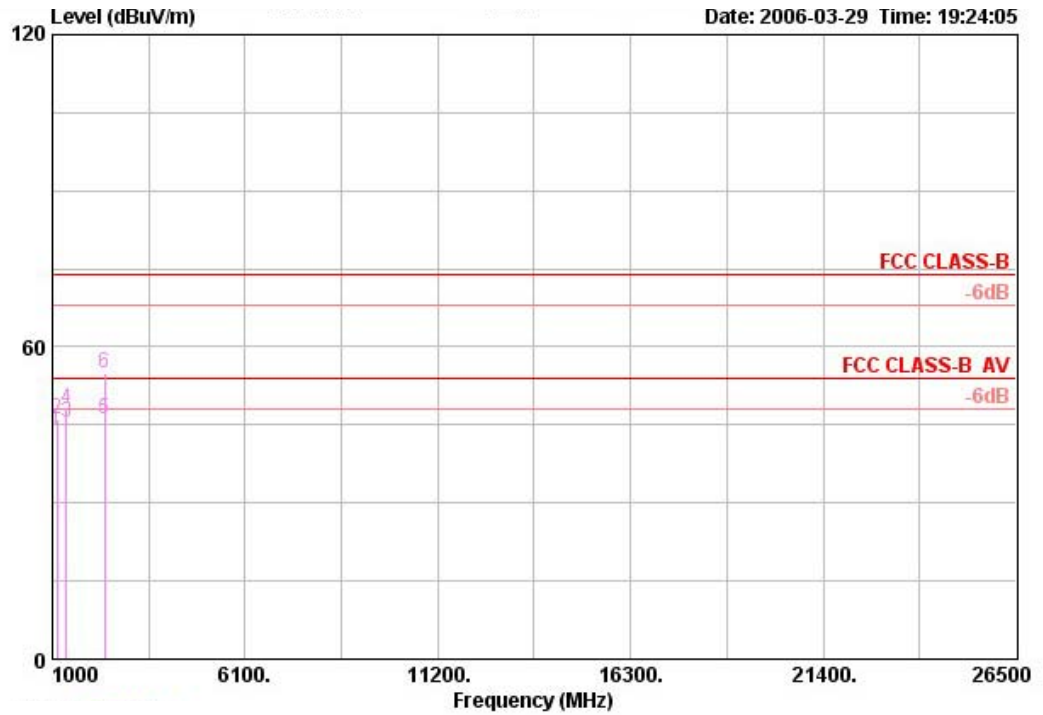

	Freq	Level	Over	Limit	Read	Antenna	Cable	Preamp	Remark	Ant	Table
	MHz	dBuV/m	dB	dBuV/m	dBuV	dB/m	dB	dB		cm	deg
1	1119.960	43.89	-10.11	54.00	49.26	24.24	4.80	34.41	AVERAGE	---	---
2	1119.960	46.18	-27.82	74.00	51.55	24.24	4.80	34.41	PEAK	---	---
3	1374.960	45.44	-8.56	54.00	49.69	24.96	5.37	34.59	AVERAGE	---	---
4	1374.960	48.15	-25.85	74.00	52.41	24.96	5.37	34.59	PEAK	---	---
5	2373.200	46.21	-7.79	54.00	45.12	28.86	7.34	35.10	AVERAGE	---	---
6	2373.200	55.08	-18.92	74.00	53.99	28.86	7.34	35.10	PEAK	---	---



Temperature	20°C	Humidity	70%
Test Engineer	Leo Hung	Configurations	draft 11n MCS15 40MHz Channel 3 Ant. A + Ant. B

Horizontal

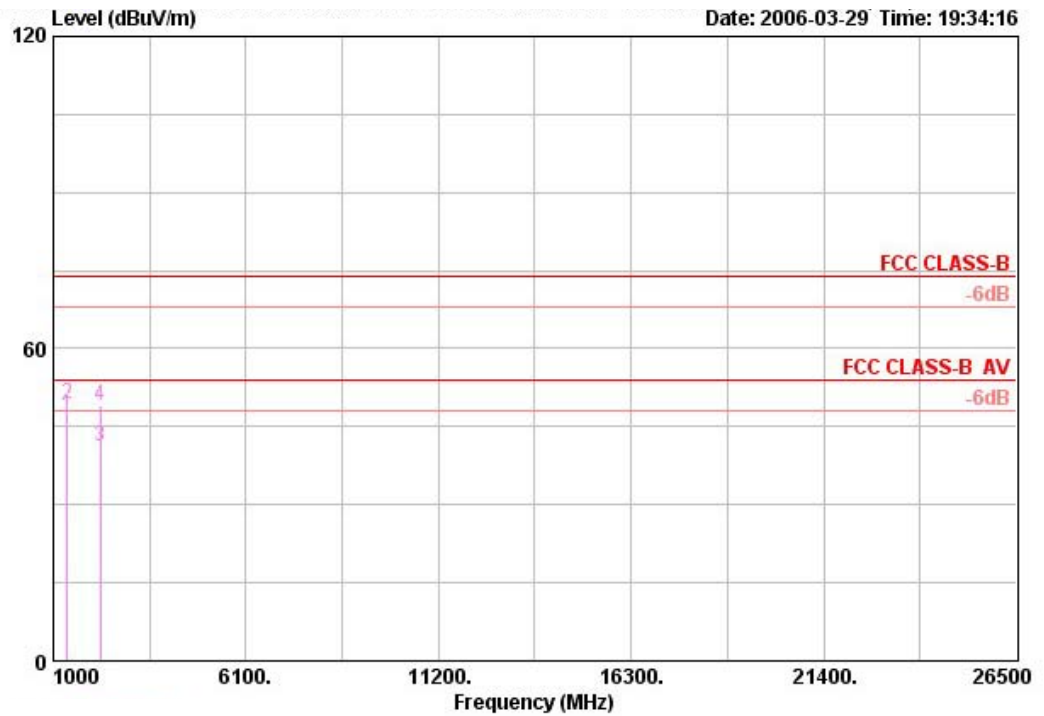

	Freq	Level	Over Limit	Limit Line	ReadAntenna Level	Antenna Factor	Cable Loss	Preamp Factor	Remark	Ant Pos	Table Pos
	MHz	dBuV/m	dB	dBuV/m	dBuV	dB/m	dB	dB		cm	deg
1	1375.000	47.25	-6.75	54.00	51.50	24.96	5.37	34.59	AVERAGE	---	---
2	1375.000	49.23	-24.77	74.00	53.49	24.96	5.37	34.59	PEAK	---	---
3	2240.000	41.21	-12.79	54.00	40.56	28.69	6.99	35.02	AVERAGE	---	---
4	2240.000	48.90	-25.10	74.00	48.24	28.69	6.99	35.02	PEAK	---	---



Temperature	20°C	Humidity	70%
Test Engineer	Leo Hung	Configurations	draft 11n MCS15 40MHz Channel 6 Ant. A + Ant. B

Vertical

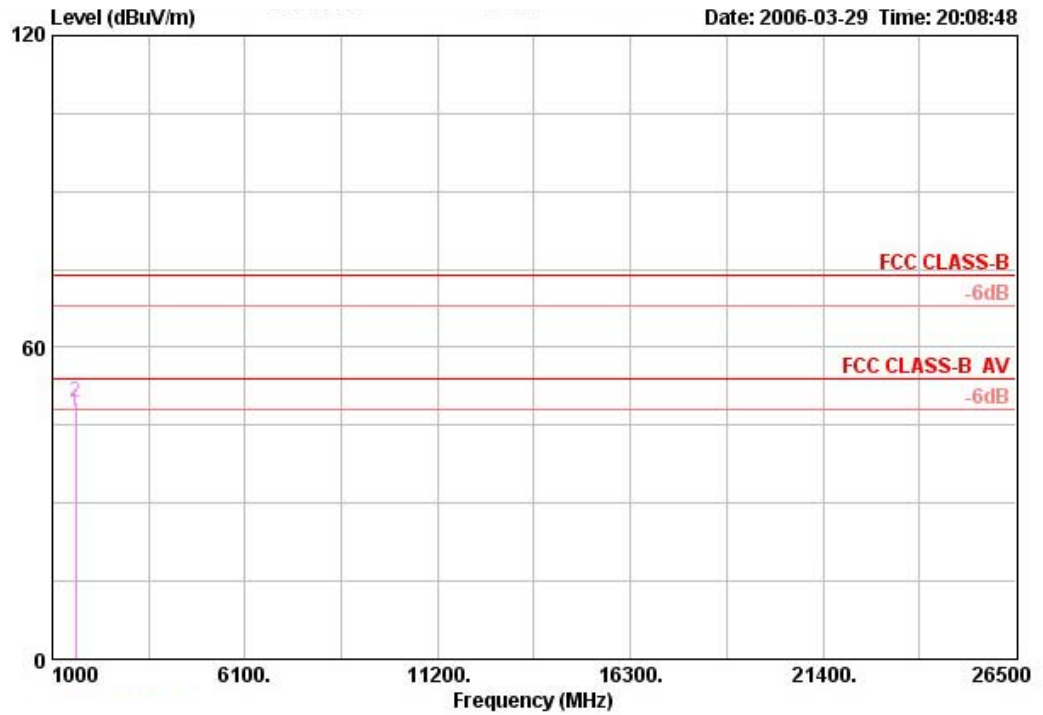

	Freq	Level	Over Limit	Limit Line	ReadAntenna Level	Antenna Factor	Cable Loss	Preamp Factor	Remark	Ant Pos	Table Pos
	MHz	dBUV/m	dB	dBUV/m	dBuV	dB/m	dB	dB		cm	deg
1	1625.000	47.81	-6.19	54.00	50.61	26.13	5.81	34.73	AVERAGE	---	---
2	1625.000	49.43	-24.57	74.00	52.22	26.13	5.81	34.73	PEAK	---	---



Temperature	20°C	Humidity	70%
Test Engineer	Leo Hung	Configurations	draft 11n MCS15 40MHz Channel 6 Ant. A + Ant. B

Horizontal

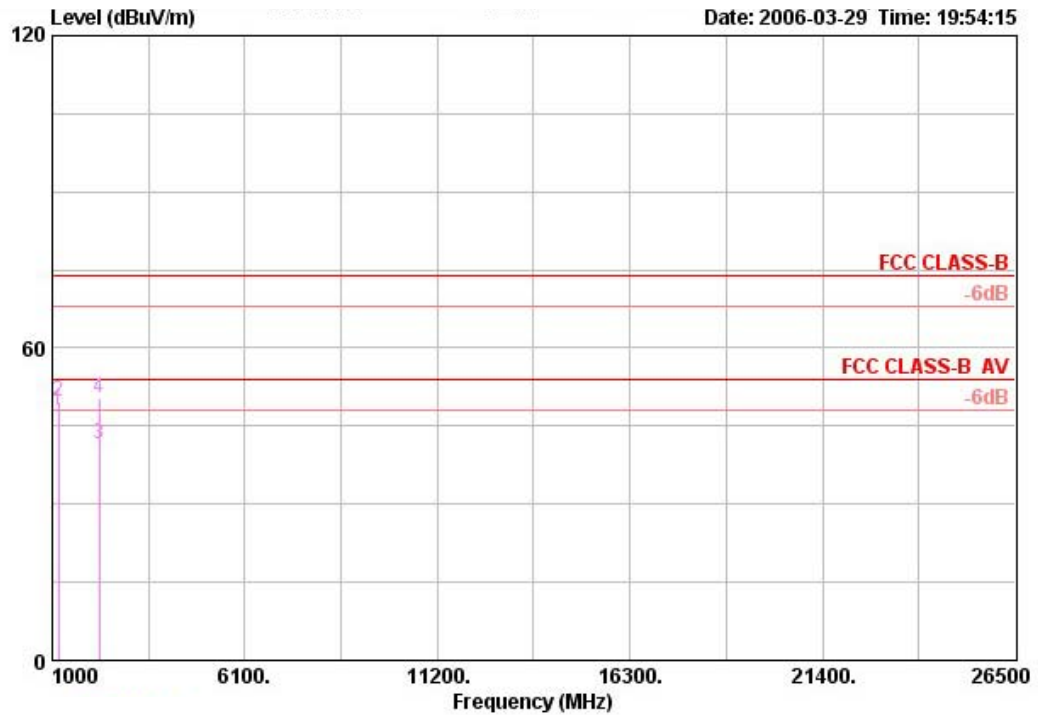

	Freq	Level	Over Limit	Limit Line	ReadAntenna Level	Antenna Factor	Cable Loss	Preamp Factor	Remark	Ant Pos	Table Pos
	MHz	dBuV/m	dB	dBuV/m	dBuV	dB/m	dB	dB		cm	deg
1	1166.700	47.91	-6.09	54.00	53.09	24.38	4.88	34.44	AVERAGE	---	---
2	1166.700	49.57	-24.43	74.00	54.75	24.38	4.88	34.44	PEAK	---	---
3	2240.000	41.37	-12.63	54.00	40.72	28.69	6.99	35.02	AVERAGE	---	---
4	2240.000	50.41	-23.59	74.00	49.76	28.69	6.99	35.02	PEAK	---	---



Temperature	20°C	Humidity	70%
Test Engineer	Leo Hung	Configurations	draft 11n MCS15 40MHz Channel 9 Ant. A + Ant. B

Vertical

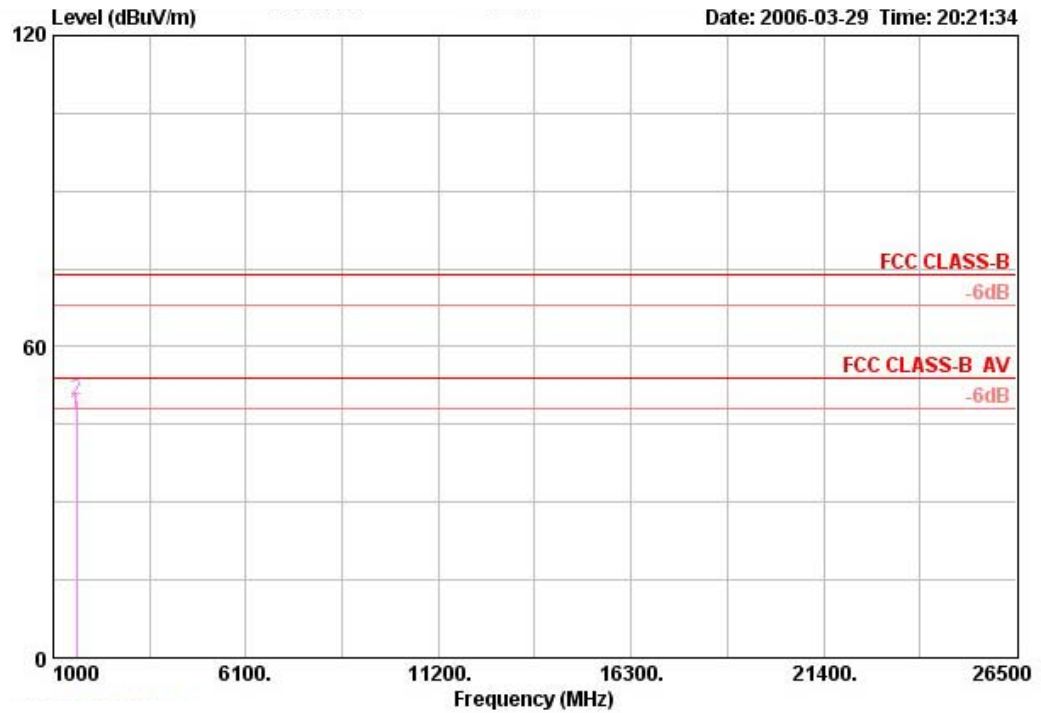

	Freq	Level	Over Limit	Limit Line	ReadAntenna Level	Antenna Factor	Cable Loss	Preamp Factor	Remark	Ant Pos	Table Pos
	MHz	dBUV/m	dB	dBUV/m	dBuV	dB/m	dB	dB		cm	deg
1	1625.000	47.15	-6.85	54.00	49.95	26.13	5.81	34.73	AVERAGE	---	---
2	1625.000	49.55	-24.45	74.00	52.35	26.13	5.81	34.73	PEAK	---	---



Temperature	20°C	Humidity	70%
Test Engineer	Leo Hung	Configurations	draft 11n MCS15 40MHz Channel 9 Ant. A + Ant. B

Horizontal

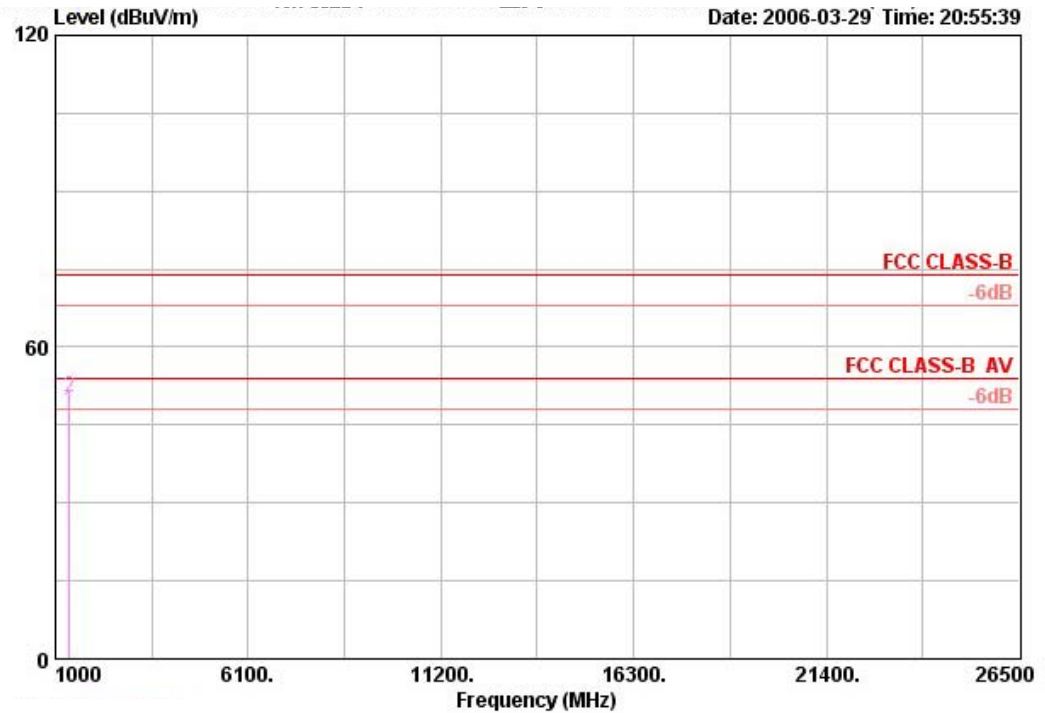

	Freq	Level	Over Limit	Limit Line	ReadAntenna Level	Antenna Factor	Cable Loss	Preamp Factor	Remark	Ant Pos	Table Pos
	MHz	dBuV/m	dB	dBuV/m	dBuV	dB/m	dB	dB		cm	deg
1	1375.040	47.68	-6.32	54.00	51.94	24.96	5.37	34.59	AVERAGE	---	---
2	1375.040	50.30	-23.70	74.00	54.56	24.96	5.37	34.59	PEAK	---	---

Note:

The amplitude of spurious emissions which are attenuated by more than 20 dB below the permissible value has no need to be reported.

Emission level (dBuV/m) = 20 log Emission level (uV/m).

Corrected Reading: Antenna Factor + Cable Loss + Read Level - Preamp Factor = Level.

4.6. Band Edge Emissions Measurement

4.6.1. Limit

20dBc in any 100 kHz bandwidth outside the operating frequency band. In case the emission fall within the restricted band specified on 15.205(a), then the 15.209(a) limit in the table below has to be followed.

Frequencies (MHz)	Field Strength (micorvolts/meter)	Measurement Distance (meters)
0.009~0.490	2400/F(KHz)	300
0.490~1.705	24000/F(KHz)	30
1.705~30.0	30	30
30~88	100	3
88~216	150	3
216~960	200	3
Above 960	500	3

4.6.2. Measuring Instruments and Setting

Please refer to section 5 in this report. The following table is the setting of the spectrum analyzer.

Spectrum Parameter	Setting
Attenuation	Auto
Span Frequency	100 MHz
RB / VB (emission in restricted band)	1MHz / 1MHz for Peak, 1 MHz / 10Hz for Average
RB / VB (other emission)	100 KHz /100 KHz for Peak

4.6.3. Test Procedures

1. The test procedure is the same as section 4.5.3, only the frequency range investigated is limited to 100MHz around bandedges.
2. In case the emission is fail due to the used RB/VB is too wide, marker-delta method of FCC Public Notice DA00-705 will be followed.

4.6.4. Test Setup Layout

This test setup layout is the same as that shown in section 4.5.4.

4.6.5. Test Deviation

There is no deviation with the original standard.

4.6.6. EUT Operation during Test

The EUT was programmed to be in continuously transmitting mode.

4.6.7. Test Result of Band Edge and Fundamental Emissions

Temperature	20°C	Humidity	70%
Test Engineer	Leo Hung	Configurations	draft 11n MCS8 20MHz Channel 1 Ant. A + Ant. B

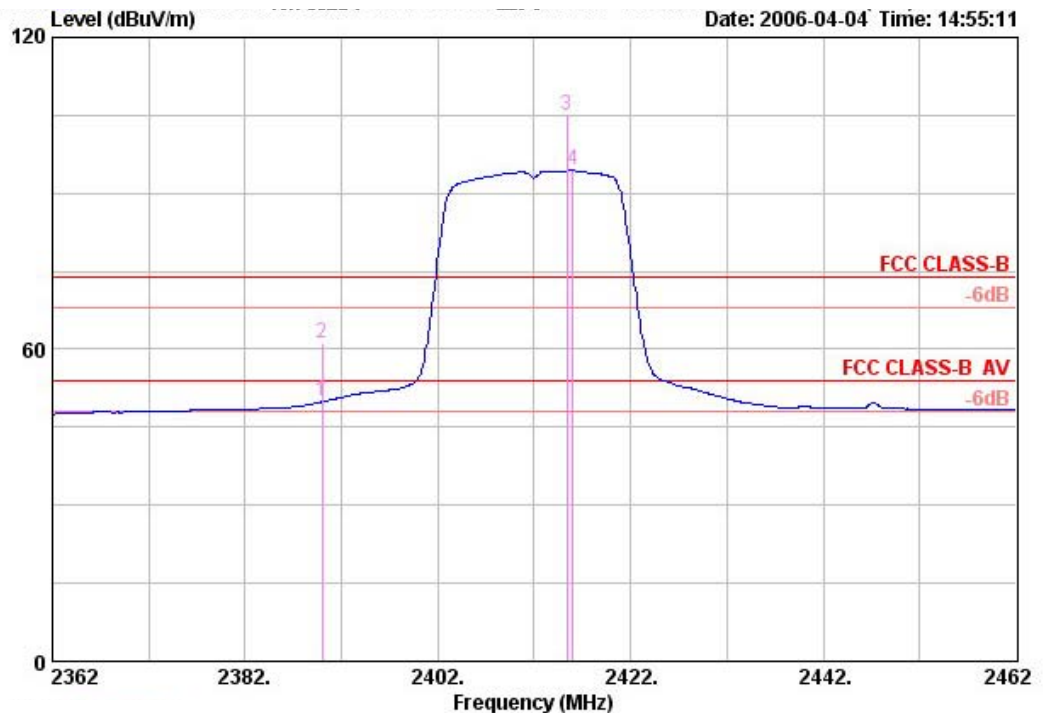

	Freq	Level	Over Limit	Limit Line	ReadAntenna Level	Antenna Factor	Cable Loss	Preamp Factor	Remark	Ant Pos	Table Pos
	MHz	dBuV/m	dB	dBuV/m	dBuV	dB/m	dB	dB		cm	deg
1 *	2390.000	49.86	-4.14	54.00	14.26	28.88	6.72	0.00	AVERAGE	---	---
2	2390.000	61.18	-12.82	74.00	25.58	28.88	6.72	0.00	PEAK	---	---
3 over	2415.400	105.03			69.34	28.90	6.80	0.00	PEAK	---	---
4 over	2416.000	94.37			58.68	28.90	6.80	0.00	AVERAGE	---	---

Channel 1 is fundamental frequency at 2412 MHz.

Temperature	20°C	Humidity	70%
Test Engineer	Leo Hung	Configurations	draft 11n MCS8 20MHz Channel 11 Ant. A + Ant. B

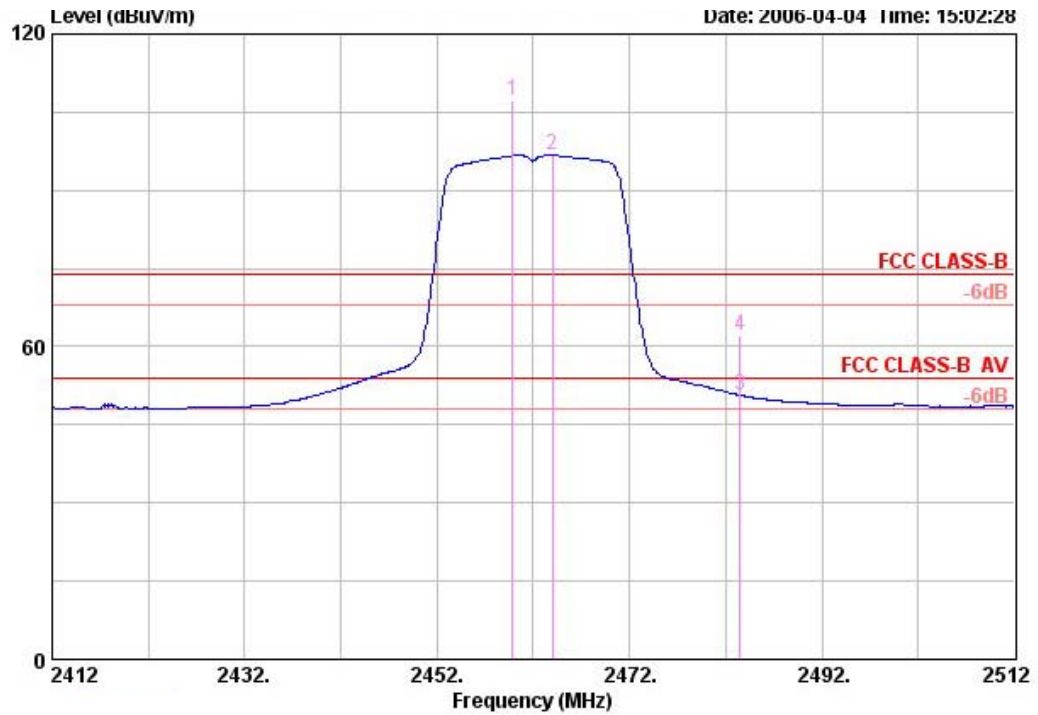

	Freq	Level	Over Limit	Limit Line	Read Level	Antenna Factor	Cable Loss	Preamp Factor	Remark	Ant Pos	Table Pos
	MHz	dBuV/m	dB	dBuV/m	dBuV	dB/m	dB	dB		cm	deg
1	over	2459.800	107.35		71.53	28.96	6.87	0.00	PEAK	---	---
2	⊕	2464.000	96.66		60.84	28.96	6.87	0.00	AVERAGE	---	---
3	*	2483.500	50.65	-3.35	54.00	14.73	28.98	6.94	AVERAGE	---	---
4		2483.500	62.18	-11.82	74.00	26.26	28.98	6.94	PEAK	---	---

Channel 11 is fundamental frequency at 2462 MHz.



Temperature	20°C	Humidity	70%
Test Engineer	Leo Hung	Configurations	draft 11n MCS8 40MHz Channel 3 Ant. A + Ant. B

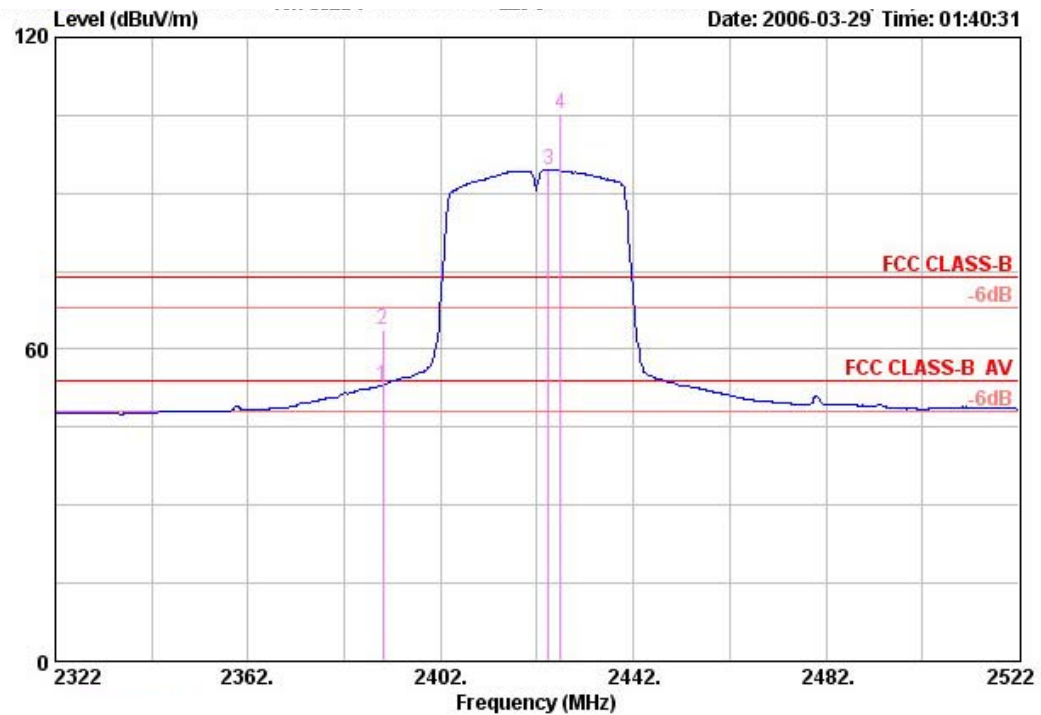

	Freq	Level	Over Limit	Limit Line	Read Level	Antenna Factor	Cable Loss	Preamp Factor	Remark	Ant Pos	Table Pos
	MHz	dBuV/m	dB	dBuV/m	dBuV	dB/m	dB	dB		cm	deg
1 *	2390.000	53.05	-0.95	54.00	17.45	28.88	6.72	0.00	AVERAGE	---	---
2	2390.000	63.84	-10.16	74.00	28.24	28.88	6.72	0.00	PEAK	---	---
3 over	2424.400	94.41			58.70	28.92	6.80	0.00	AVERAGE	---	---
4 over	2426.800	105.34			69.63	28.92	6.80	0.00	PEAK	---	---

Channel 3 is fundamental frequency at 2422 MHz.



Temperature	20°C	Humidity	70%
Test Engineer	Leo Hung	Configurations	draft 11n MCS8 40MHz Channel 9 Ant. A + Ant. B

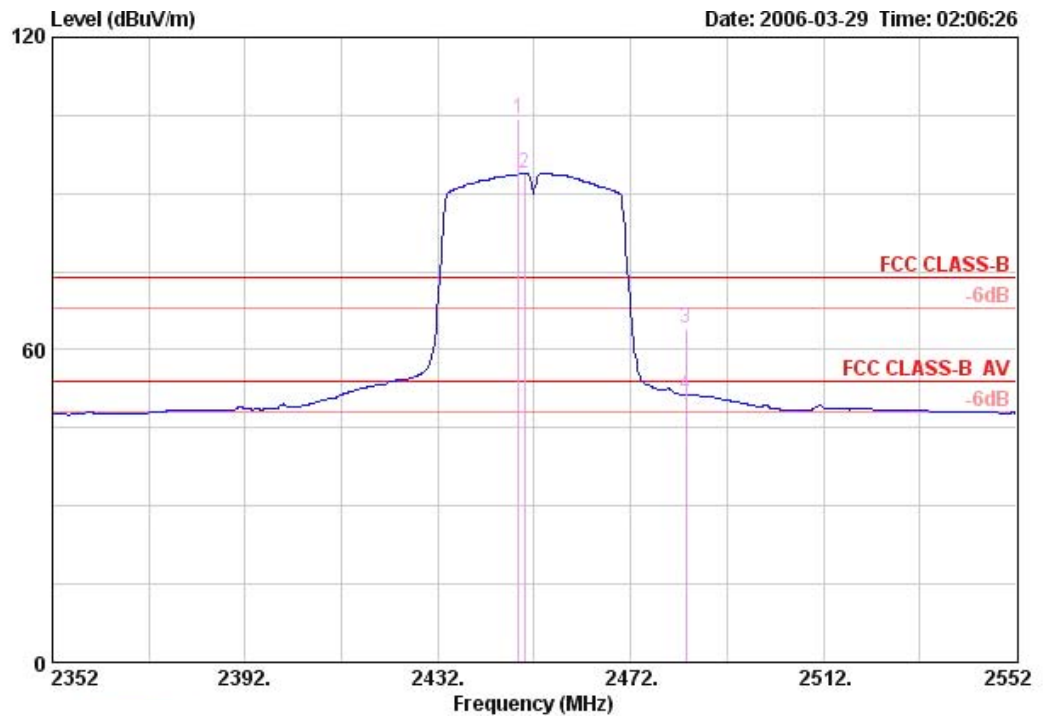

	Freq	Level	Over Limit	Limit Line	ReadAntenna Level	Antenna Factor	Cable Loss	Preamp Factor	Remark	Ant Pos	Table Pos
	MHz	dBUV/m	dB	dBUV/m	dBuV	dB/m	dB	dB		cm	deg
1 over	2448.800	104.43			68.62	28.94	6.87	0.00	PEAK	---	---
2 over	2450.000	93.83			58.03	28.94	6.87	0.00	AVERAGE	---	---
3	2483.500	64.12	-9.88	74.00	28.20	28.98	6.94	0.00	PEAK	---	---
4 *	2483.500	51.43	-2.57	54.00	15.51	28.98	6.94	0.00	AVERAGE	---	---

Channel 9 is fundamental frequency at 2452 MHz.



Temperature	20°C	Humidity	70%
Test Engineer	Leo Hung	Configurations	draft 11n MCS15 20MHz Channel 1 Ant. A + Ant. B

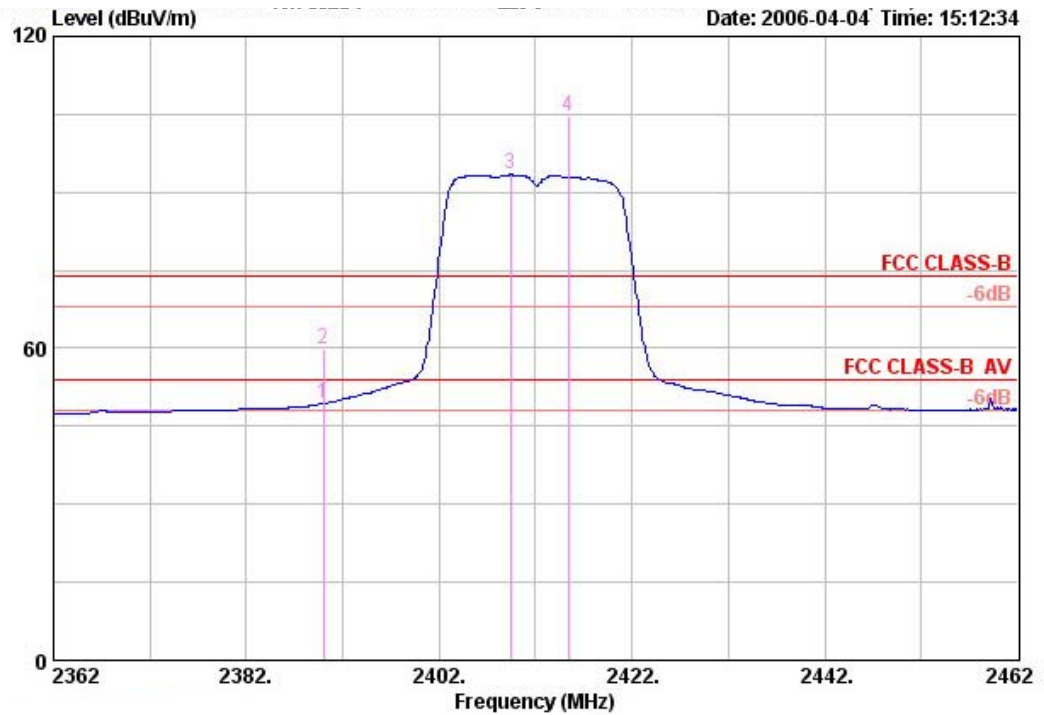

	Freq	Level	Over Limit	Limit Line	ReadAntenna Level	Antenna Factor	Cable Loss	Preamp Factor	Remark	Ant Pos	Table Pos
	MHz	dBUV/m	dB	dBUV/m	dBuV	dB/m	dB	dB		cm	deg
1 *	2390.000	49.38	-4.62	54.00	13.78	28.88	6.72	0.00	AVERAGE	---	---
2	2390.000	59.99	-14.01	74.00	24.39	28.88	6.72	0.00	PEAK	---	---
3 over	2409.400	93.38			57.69	28.90	6.80	0.00	AVERAGE	---	---
4 over	2415.400	104.61			68.92	28.90	6.80	0.00	PEAK	---	---

Channel 1 is fundamental frequency at 2412 MHz.



Temperature	20°C	Humidity	70%
Test Engineer	Leo Hung	Configurations	draft 11n MCS15 20MHz Channel 11 Ant. A + Ant. B

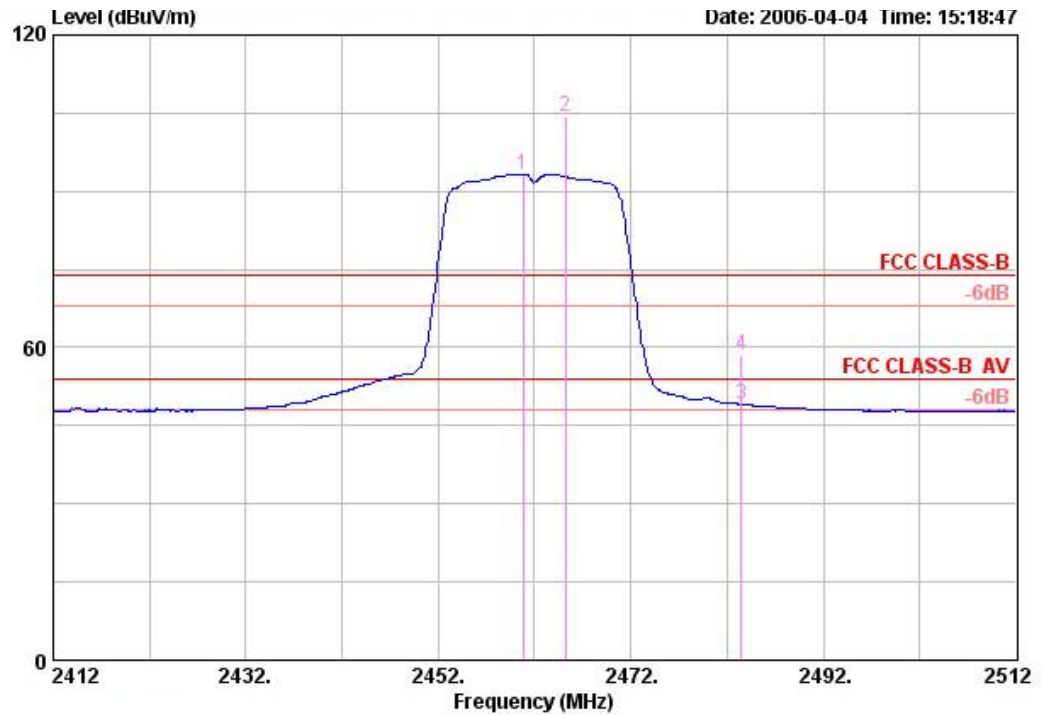

	Freq	Level	Over Limit	Limit Line	Read Level	Antenna Factor	Cable Loss	Preamp Factor	Remark	Ant Pos	Table Pos
	MHz	dBuV/m	dB	dBuV/m	dBuV	dB/m	dB	dB		cm	deg
1 over	2460.800	93.23			57.40	28.96	6.87	0.00	AVERAGE	---	---
2 over	2465.200	104.36			68.53	28.96	6.87	0.00	PERK	---	---
3 *	2483.500	49.08	-4.92	54.00	13.16	28.98	6.94	0.00	AVERAGE	---	---
4	2483.500	58.64	-15.36	74.00	22.72	28.98	6.94	0.00	PERK	---	---

Channel 11 is fundamental frequency at 2462 MHz.



Temperature	20°C	Humidity	70%
Test Engineer	Leo Hung	Configurations	draft 11n MCS15 40MHz Channel 3 Ant. A + Ant. B

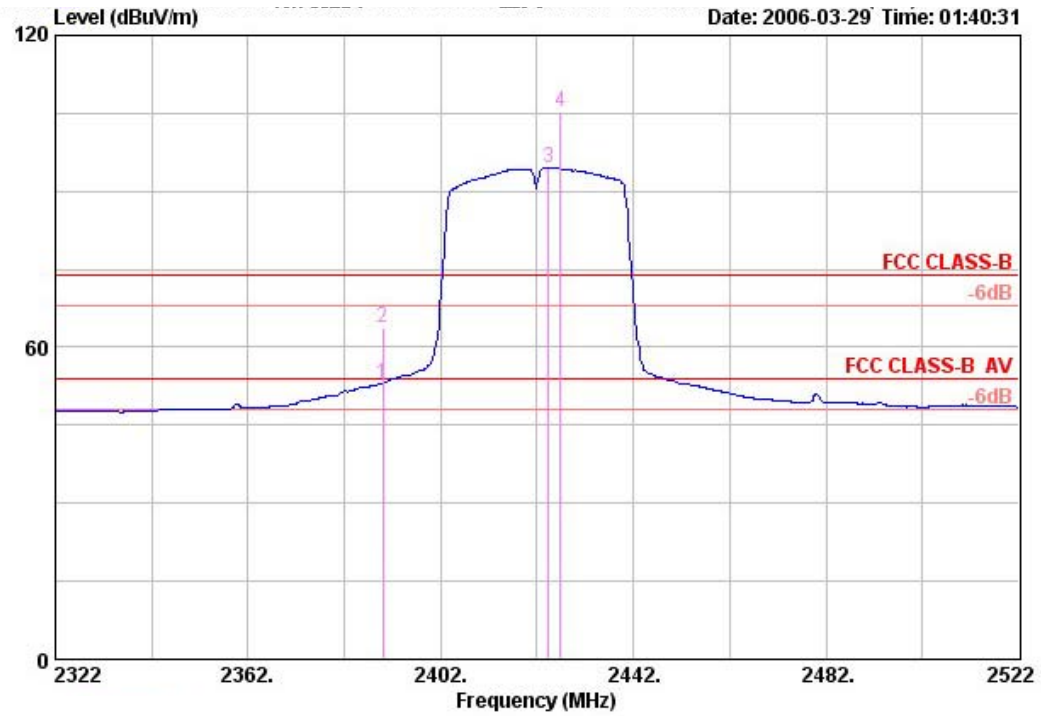

	Freq	Level	Over Limit	Limit Line	Read Level	Antenna Factor	Cable Loss	Preamp Factor	Remark	Ant Pos	Table Pos
	MHz	dBuV/m	dB	dBuV/m	dBuV	dB/m	dB	dB		cm	deg
1 *	2390.000	53.05	-0.95	54.00	17.45	28.88	6.72	0.00	AVERAGE	---	---
2	2390.000	63.84	-10.16	74.00	28.24	28.88	6.72	0.00	PEAK	---	---
3 over	2424.400	94.41			58.70	28.92	6.80	0.00	AVERAGE	---	---
4 over	2426.800	105.34			69.63	28.92	6.80	0.00	PEAK	---	---

Channel 3 is fundamental frequency at 2422 MHz.



Temperature	20°C	Humidity	70%
Test Engineer	Leo Hung	Configurations	draft 11n MCS15 40MHz Channel 9 Ant. A + Ant. B

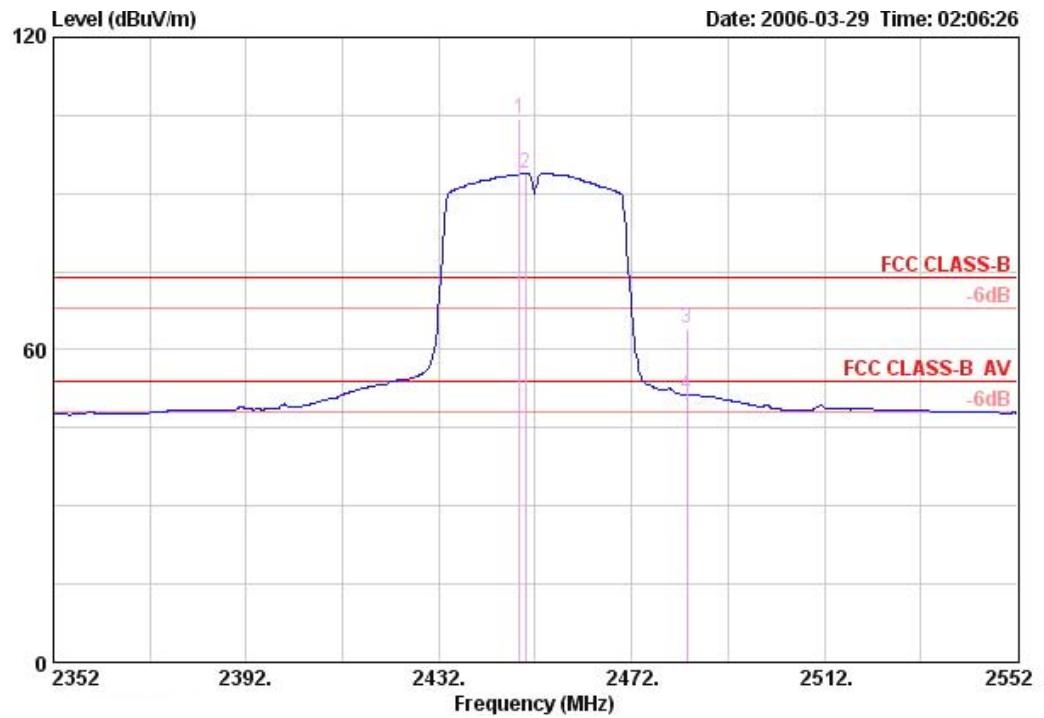

	Freq	Level	Over	Limit	Line	Read	Antenna	Cable	Preamp	Remark	Ant	Table
	MHz	dBuV/m	dB	dBuV/m	dBuV	dB/m	dB	dB	dB		cm	deg
1	over	2448.800	104.43		68.62	28.94	6.87	0.00	0.00	PEAK	---	---
2	over	2450.000	93.83		58.03	28.94	6.87	0.00	0.00	AVERAGE	---	---
3		2483.500	64.12	-9.88	74.00	28.20	28.98	6.94	0.00	PEAK	---	---
4	*	2483.500	51.43	-2.57	54.00	15.51	28.98	6.94	0.00	AVERAGE	---	---

Channel 9 is fundamental frequency at 2452 MHz.

Note:

Emission level (dBUV/m) = 20 log Emission level (uV/m).

Corrected Reading: Antenna Factor + Cable Loss + Read Level - Preamp Factor = Level.

Receiving maximum band edge emissions are Horizontal Polarization.



For Emission not in Restricted Band

Low Band Edge Plot on Configuration draft 11n MCS8 20MHz Ant. A + Ant. B / 2412 MHz

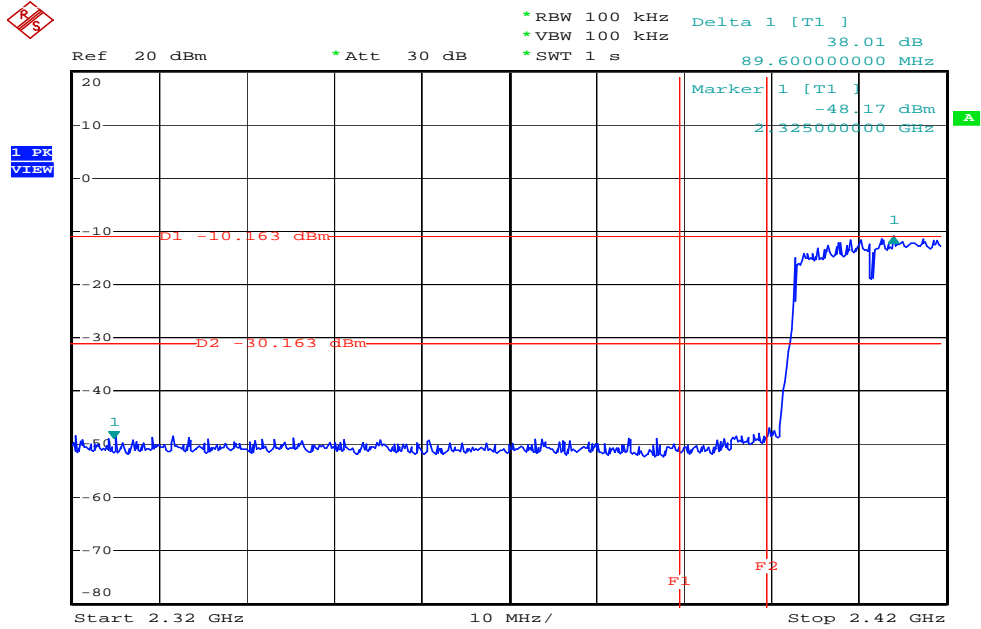

Date: 4.APR.2006 18:27:39

High Band Edge Plot on Configuration draft 11n MCS8 20MHz Ant. A + Ant. B / 2462 MHz

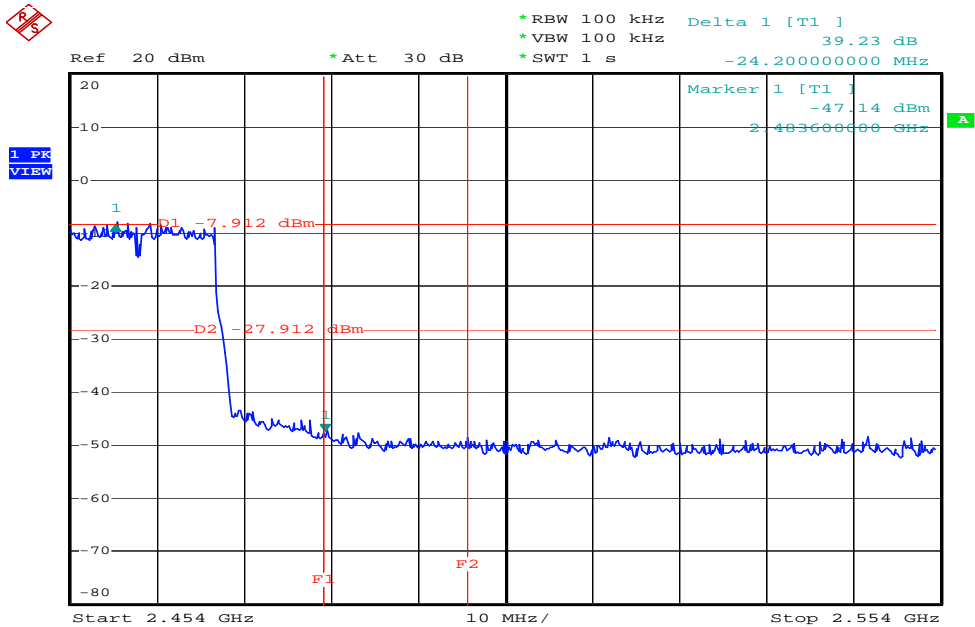

Date: 4.APR.2006 18:30:27

For Emission not in Restricted Band

Low Band Edge Plot on Configuration draft 11n MCS8 40MHz Ant. A + Ant. B / 2422 MHz

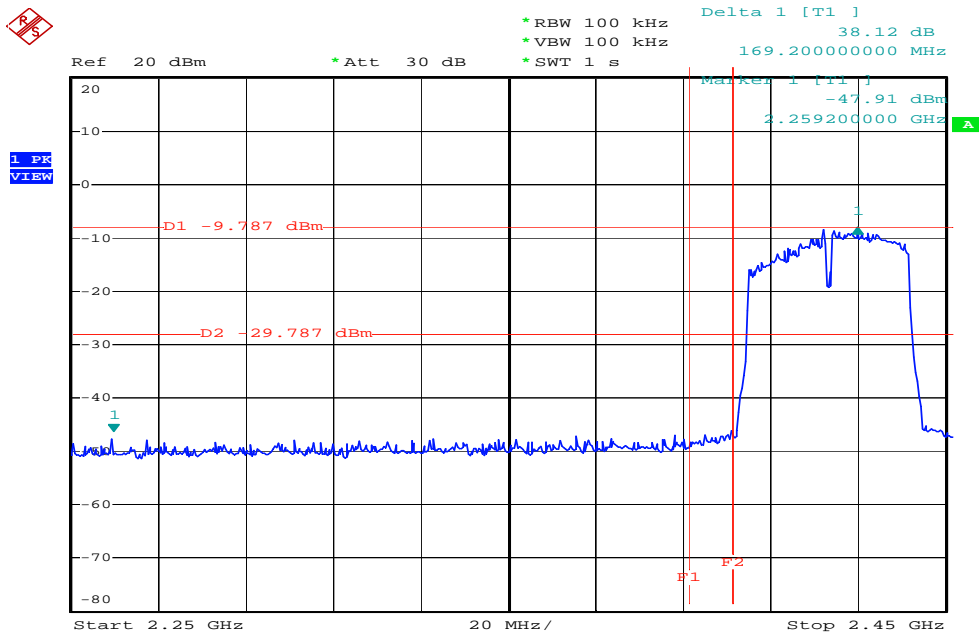

Date: 3.APR.2006 19:27:21

High Band Edge Plot on Configuration draft 11n MCS8 40MHz Ant. A + Ant. B / 2452 MHz

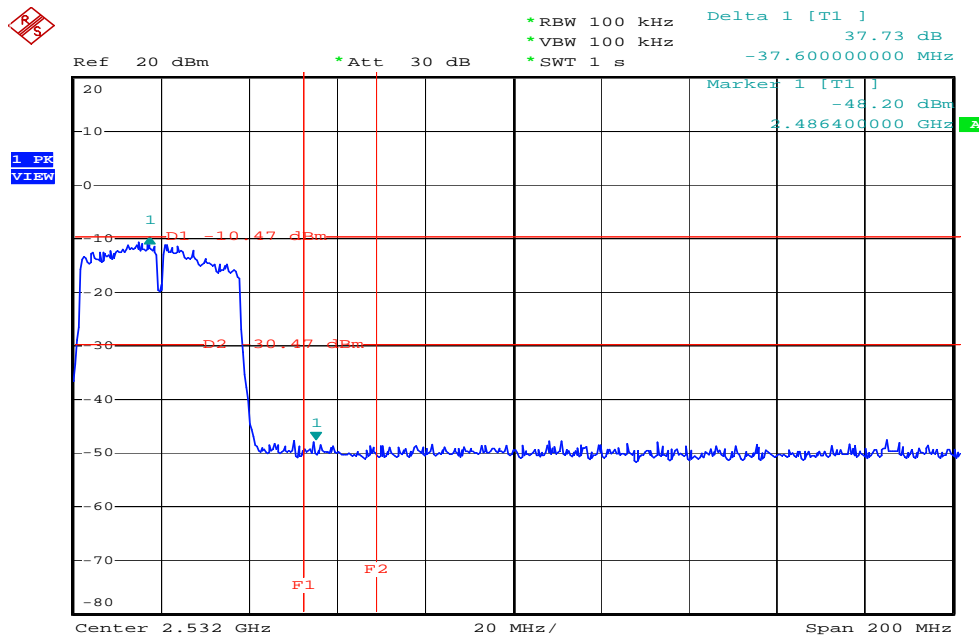

Date: 3.APR.2006 19:35:25



For Emission not in Restricted Band

Low Band Edge Plot on Configuration draft 11n MCS15 20MHz Ant. A + Ant. B / 2412 MHz

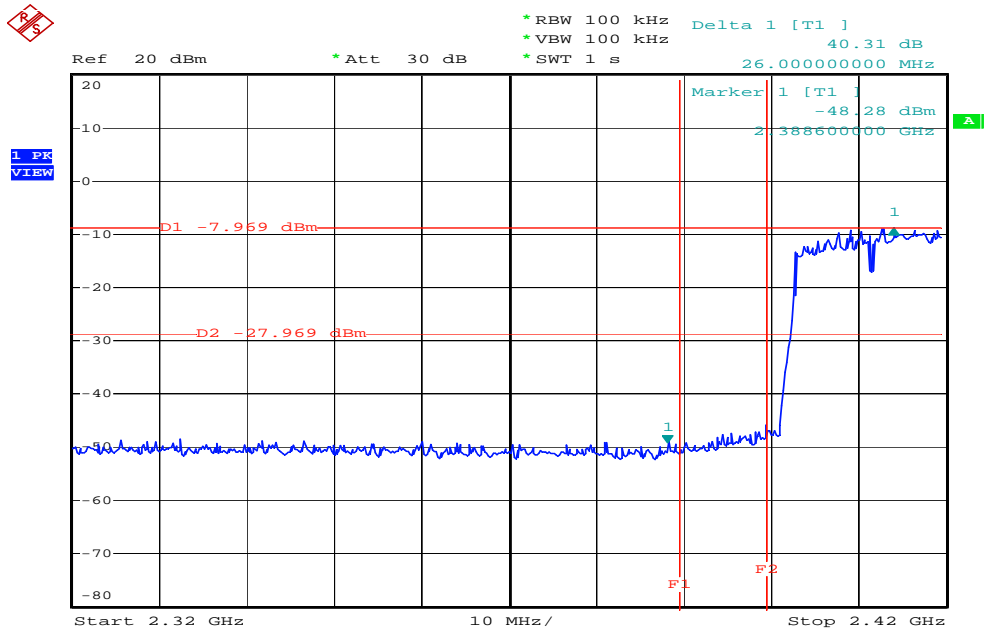

Date: 4.APR.2006 18:48:25

High Band Edge Plot on Configuration draft 11n MCS15 20MHz Ant. A + Ant. B / 2462 MHz

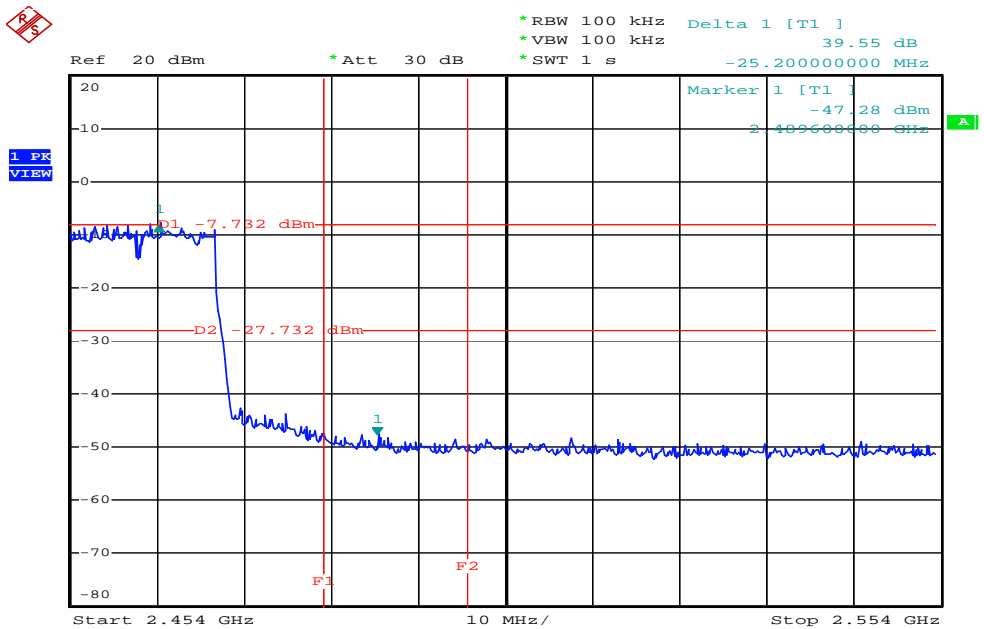

Date: 4.APR.2006 18:40:10

Low Band Edge Plot on Configuration draft 11n MCS15 40MHz Ant. A + Ant. B / 2422 MHz

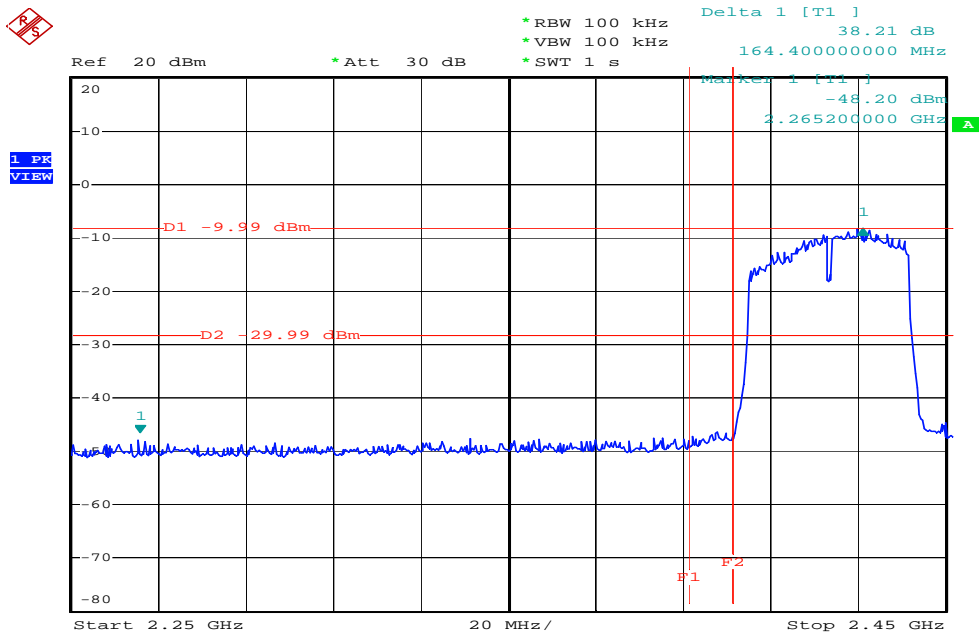

Date: 3.APR.2006 19:39:41

High Band Edge Plot on Configuration draft 11n MCS15 40MHz Ant. A + Ant. B / 2452 MHz

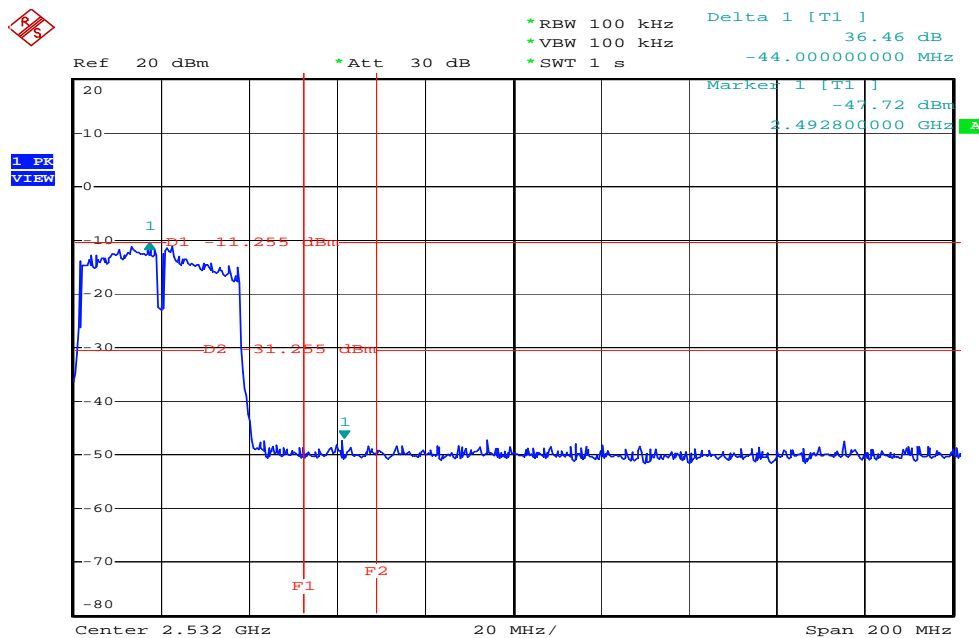

Date: 3.APR.2006 19:43:49



4.7. Antenna Requirements

4.7.1. Limit

Except for special regulations, the Low-power Radio-frequency Devices must not be equipped with any jacket for installing an antenna with extension cable. An intentional radiator shall be designed to ensure that no antenna other than that furnished by the responsible party shall be used with the device. The use of a permanently attached antenna or of an antenna that uses a unique coupling to the intentional radiator shall be considered sufficient to comply with the provisions of this Section. The manufacturer may design the unit so that the user can replace a broken antenna, but the use of a standard antenna jack or electrical connector is prohibited. Further, this requirement does not apply to intentional radiators that must be professionally installed.

4.7.2. Antenna Connector Construction

Please refer to section 3.3 in this test report, all antenna connectors comply with the requirements.

5. LIST OF MEASURING EQUIPMENTS

Instrument	Manufacturer	Model No.	Serial No.	Characteristics	Calibration Date	Remark
EMC Receiver	R&S	ESCS 30	100174	9kHz – 2.75GHz	Feb. 22, 2006	Conduction (CO04-HY)
LISN	MessTec	NNB-2/16Z	99079	9kHz – 30MHz	Dec. 19, 2005	Conduction (CO04-HY)
LISN (Support Unit)	EMCO	3810/2NM	9708-1839	9kHz – 30MHz	Mar. 18, 2006	Conduction (CO04-HY)
RF Cable-CON	UTIFLEX	3102-26886-4	CB049	9kHz – 30MHz	Apr. 20, 2005	Conduction (CO04-HY)
EMI Filter	LINDGREN	LRE-2030	2651	< 450 Hz	N/A	Conduction (CO04-HY)
3m Semi Anechoic Chamber	SIDT FRANKONIA	SAC-3M	03CH03-HY	30 MHz - 1 GHz 3m	Jun. 16, 2005	Radiation (03CH03-HY)
Amplifier	SCHAFFNER	CPA9231A	3565	9 kHz - 2 GHz	Jan. 18, 2006	Radiation (03CH03-HY)
Amplifier	Agilent	8449B	3008A02120	1 GHz - 26.5 GHz	May. 31, 2005	Radiation (03CH03-HY)
Amplifier	MITEQ	AMF-6F-260400	923364	26.5 GHz - 40 GHz	Jan. 24, 2006*	Radiation (03CH03-HY)
Spectrum Analyzer	R&S	FSP40	100004/040	9 kHz - 40 GHz	Sep. 30, 2005	Radiation (03CH03-HY)
Loop Antenna	R&S	HFH2-Z2	860004/001	9 kHz - 30 MHz	May. 24, 2004*	Radiation (03CH03-HY)
Biconical Antenna	SCHWARZBECK	VHBB 9124	301	30 MHz - 200 MHz	Jul. 22, 2005	Radiation (03CH03-HY)
Log Antenna	SCHWARZBECK	VUSLP 9111	221	200 MHz - 1 GHz	Jul. 22, 2005	Radiation (03CH03-HY)
Horn Antenna	EMCO	3115	6741	1 GHz - 18 GHz	Apr. 22, 2005	Radiation (03CH03-HY)
Horn Antenna	SCHWARZBECK	BBHA9170	BBHA9170154	15 GHz - 40 GHz	Jun. 09, 2004*	Radiation (03CH03-HY)
RF Cable-R03m	Jye Bao	RG142	CB021	30 MHz - 1 GHz	Dec.02, 2005	Radiation (03CH03-HY)
RF Cable-HIGH	SUHNER	SUCOFLEX 106	03CH03-HY	1 GHz - 40 GHz	Dec.02, 2005	Radiation (03CH03-HY)
Turn Table	HD	DS 420	420/650/00	0 - 360 degree	N/A	Radiation (03CH03-HY)
Antenna Mast	HD	MA 240	240/560/00	1 m - 4 m	N/A	Radiation (03CH03-HY)
Power sensor	R&S	NRV-Z55	100049	DC ~ 40GHz	Jul. 06, 2005	Conducted (TH01-HY)
Power Sensor	R&S	NRV-Z32	100057	30MHz ~ 6GHz	Apr. 28, 2005	Conducted (TH01-HY)
AC power source	HPC	HPA-500W	HPA-9100024	AC 0 ~ 300V	Apr. 21, 2005	Conducted (TH01-HY)
DC power source	G.W.	GPC-6030D	C671845	DC 1V ~ 60V	Dec. 28, 2005	Conducted (TH01-HY)
Temp. and Humidity Chamber	KSON	THS-C3L	612	N/A	Oct. 01, 2005	Conducted (TH01-HY)



Instrument	Manufacturer	Model No.	Serial No.	Characteristics	Calibration Date	Remark
RF CABLE-1m	Jye Bao	RG142	CB034-1m	20MHz ~ 7GHz	Dec. 30, 2005	Conducted (TH01-HY)
RF CABLE-2m	Jye Bao	RG142	CB035-2m	20MHz ~ 1GHz	Dec. 30, 2005	Conducted (TH01-HY)
Oscilloscope	Tektronix	TDS1012	CO38515	100MHz / 1GS/s	Apr. 15, 2005*	Conducted (TH01-HY)
Signal Generator	R&S	SMR40	100116	10MHz ~ 40GHz	Dec. 30, 2005	Conducted (TH01-HY)
Data Generator	Tektronix	DG2030	063-2920-50	0.1Hz~400MHz	Jun. 02, 2005	Conducted (TH01-HY)

※ Calibration Interval of instruments listed above is one year.

* Calibration Interval of instruments listed above is two year.

6. SPORTON COMPANY PROFILE

SPORTON Lab. was established in 1986 with one shielded room: the first private EMI test facility, offering local manufacturers an alternative EMI test facility apart from ERSO. In 1988, one 3M and 10M/3M open area test site were setup and also obtained official accreditation from FCC, VCCI and NEMKO. In 1993, a Safety laboratory was founded and obtained accreditation from UL of USA, CSA of Canada and TUV (Rhineland & PS) of Germany. In 1995, one EMC lab, including EMI and EMS test facilities was setup. In 1997, SPORTON Group has provided financial expense to relocate the headquarter to Orient Scientific Park in Taipei Hsien to offer more comprehensive, more qualified and better service to local suppliers and manufactures. In 1999, Safety Group and Component Group were setup. In 2001, SPORTON has established 3M/10M chamber in Hwa Ya Technology Park.

6.1. Test Location

SHIJR	ADD : 6Fl., No. 106, Sec. 1, Shintai 5th Rd., Shijr City, Taipei, Taiwan 221, R.O.C. TEL : 02-2696-2468 FAX : 02-2696-2255
HWA YA	ADD : No. 52, Hwa Ya 1st Rd., Kwei-Shan Hsiang, Tao Yuan Hsien, Taiwan, R.O.C. TEL : 03-327-3456 FAX : 03-318-0055
LINKOU	ADD : No. 30-2, Dingfu Tsuen, Linkou Shiang, Taipei, Taiwan 244, R.O.C. TEL : 02-2601-1640 FAX : 02-2601-1695
DUNGHU	ADD : No. 3, Lane 238, Kangle St., Neihu Chiu, Taipei, Taiwan 114, R.O.C. TEL : 02-2631-4739 FAX : 02-2631-9740
JUNGHE	ADD : 7Fl., No. 758, Jungjeng Rd., Junghe City, Taipei, Taiwan 235, R.O.C. TEL : 02-8227-2020 FAX : 02-8227-2626
NEIHU	ADD : 4Fl., No. 339, Hsin Hu 2 nd Rd., Taipei 114, Taiwan, R.O.C. TEL : 02-2794-8886 FAX : 02-2794-9777
JHUBEI	ADD : No.8, Lane 728, Bo-ai St., Jhubei City, Hsinchu County 302, Taiwan, R.O.C. TEL : 03-656-9065 FAX : 03-656-9085

7. NVLAP CERTIFICATE OF ACCREDITATION

United States Department of Commerce
National Institute of Standards and Technology

NVLAP[®]

Certificate of Accreditation to ISO/IEC 17025:1999

NVLAP LAB CODE: 200079-0

Sporton International, Inc. Hwa Ya EMC Laboratory
Tao Yuan Hsien 333
TAIWAN

*is recognized by the National Voluntary Laboratory Accreditation Program for conformance with criteria set forth in
NIST Handbook 150:2001 and all requirements of ISO/IEC 17025:1999.
Accreditation is granted for specific services, listed on the Scope of Accreditation, for:*

ELECTROMAGNETIC COMPATIBILITY AND TELECOMMUNICATIONS

2006-01-01 through 2006-12-31
Effective dates



[Signature]
For the National Institute of Standards and Technology