

RF Test Report

Applicant : Mobilehelp, LLC

Product Name : Cellular Base Station Gen4.0 Plus

Trade Name : MobileHelp

Model Number : DC-CBS4-03, DC-CBS4-13

Applicable Standard : FCC 47 CFR PART 15 SUBPART C
ANSI C63.10:2013

Received Date : Aug. 17, 2022

Test Period : Sep. 06 ~ Nov. 17, 2022

Issued Date : Dec. 06, 2022

Issued by

Eurofins E&E Wireless Taiwan Co., Ltd.
No. 140-1, Changan Street, Bade District,
Taoyuan City 334025, Taiwan (R.O.C.)
Tel : +886-3-2710188 / Fax : +886-3-2710190



Taiwan Accreditation Foundation accreditation number: 1330
Frequency Range: 9 kHz to 325 GHz (Bade test site)
Frequency Range: 9 kHz to 40 GHz (Wugu test site)
Test Firm MRA designation number: TW0010

Note:

- 1.The test results are valid only for samples provided by customers and under the test conditions described in this report.
- 2.This report shall not be reproduced except in full, without the written approval of Eurofins E&E Wireless Taiwan Co., Ltd.
- 3.The relevant information is provided by customers in this test report. According to the correctness, appropriateness or completeness of the information provided by the customer, if there is any doubt or error in the information which affects the validity of the test results, the laboratory does not take the responsibility.

Revision History

Version	Issued Date	Revisions	Revised By
00	Dec. 06, 2022	Initial Issue	Snow Wang

Verification of Compliance

Applicant : Mobilehelp, LLC

Product Name : Cellular Base Station Gen4.0 Plus

Trade Name : MobileHelp

Model Number : DC-CBS4-03, DC-CBS4-13

FCC ID : PXTCBS4-13

Applicable Standard : FCC 47 CFR PART 15 SUBPART C
ANSI C63.10:2013

Test Result : Complied

Performing Lab. : Eurofins E&E Wireless Taiwan Co., Ltd.
No. 140-1, Changan Street, Bade District,
Taoyuan City 334025, Taiwan (R.O.C.)
Tel : +886-3-2710188 / Fax : +886-3-2710190
Taiwan Accreditation Foundation accreditation number: 1330



Eurofins E&E Wireless Taiwan Co., Ltd. tested the above equipment in accordance with the requirements set forth in the above standards. All indications of Pass/Fail in this report are opinions expressed by Eurofins E&E Wireless Taiwan Co., Ltd. based on interpretations and/or observations of test results. The test results show that the equipment tested is capable of demonstrating compliance with the requirements as documented in this report.

Approved By : _____

TABLE OF CONTENTS

1	General Information	5
1.1.	Summary of Test Result.....	5
1.2.	Testing Location.....	5
1.3.	Measurement Uncertainty.....	6
2	EUT Description	7
3	Test Methodology	8
3.1.	Mode of Operation	8
3.2.	EUT Test Step.....	8
3.3.	Configuration of Test System Details	8
3.4.	Test Instruments	10
3.5.	Test Site Environment.....	12
4	Measurement Procedure	13
4.1.	AC Power Line Conducted Emission Measurement	13
4.2.	Radiated Emission Measurement	15
4.3.	Duration of transmission	19
4.4.	Bandwidth measurement	20
4.5.	Antenna Requirement.....	21
5	Test Results	22
5.1.	Conducted Emission.....	22
5.2.	Conducted Test Results.....	28
5.3.	Radiated Emission Measurement.....	30
Appendix A. Test Setup Photographs		

1 General Information

1.1. Summary of Test Result

Standard	Item	Results	Remark
15.207(a)	Conducted Emissions Voltage	PASS	---
15.231(e)	Radiated Emission Limits	PASS	---
15.231	Duration of transmission	PASS	---
15.231(c)	Bandwidth measurement	PASS	---
15.203	Antenna Requirement	PASS	----

Standard	Description
CFR47, Part 15, Subpart C	Intentional Radiators
ANSI C63. 10: 2013	American National Standard of Procedures for Compliance Testing of Unlicensed Wireless Devices

Decision Rule

- Uncertainty is not included.
- Uncertainty is included.

1.2. Testing Location

Lab Name: Eurofins E&E Wireless Taiwan Co., Ltd.

Site Address: No. 140-1, Changan Street, Bade District, Taoyuan City 334025, Taiwan (R.O.C.)

Site Address: No. 2, Wuquan 5th Rd. Wugu Dist., New Taipei City, Taiwan (R.O.C.)

1.3. Measurement Uncertainty

Test Item	Frequency Range	Uncertainty
Conducted Emission	150 kHz ~ 30 MHz	2.7 dB
Radiated Emission	9 kHz ~ 30 MHz	2.2 dB
	30 MHz ~ 1000 MHz	5.1 dB
	1000 MHz ~ 18000 MHz	5.2 dB
	18000 MHz ~ 26500 MHz	4.6 dB
	26500 MHz ~ 40000 MHz	4.6 dB
RF Bandwidth		4.7 %
Frequency Stability		1.3×10^{-7}

2 EUT Description

Applicant	Mobilehelp, LLC 5050 Conference Way North, Suite 125, Boca Raton, FL 33431
Product Name	Cellular Base Station Gen4.0 Plus
Trade Name	MobileHelp
Model Number	DC-CBS4-03, DC-CBS4-13
Difference description of model number	DC-CBS4-03 is for AT&T and DC-CBS4-13 is for Verizon
FCC ID	PXTCBS4-13
Frequency Range	433.92 MHz
Modulation Type	ASK
Number of Channels	1 Channel
Antenna Type	PCB Antenna
Antenna Max. Gain	-1.94 dBi
Operate Temp. Range	-10 ~ +50 °C
EUT Power Rating	5 Vdc, 2 A

3 Test Methodology

3.1. Mode of Operation

In the test report use EUT model: DC-CBS4-03 to operate testing.
 The following test mode(s) were scanned during the preliminary test :

Test Mode
Transmit Mode
RFID

Eurofins has verified the construction and function in typical operation. All the test modes were carried out with the EUT in normal operation.

3.2. EUT Test Step

1.	Setup the EUT shown on “Configuration of Test System Details”.
2.	Turn on the power of all equipment.
3.	The EUT will start to operate function.

3.3. Configuration of Test System Details

Conduction Emission

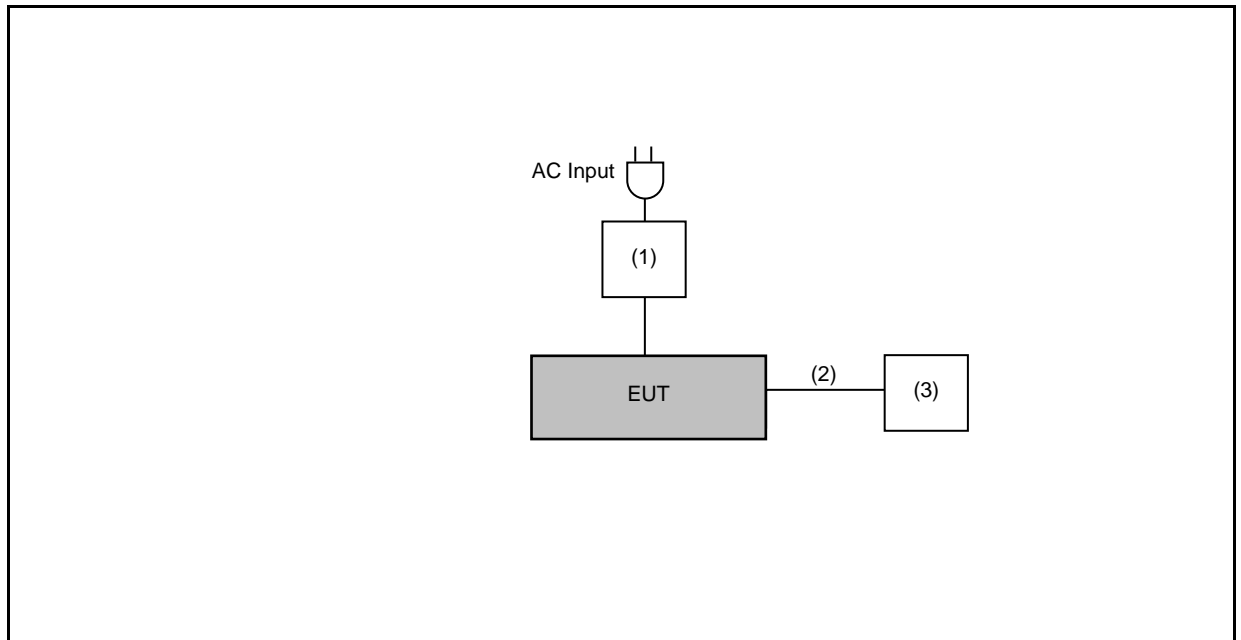

Radiated Emission

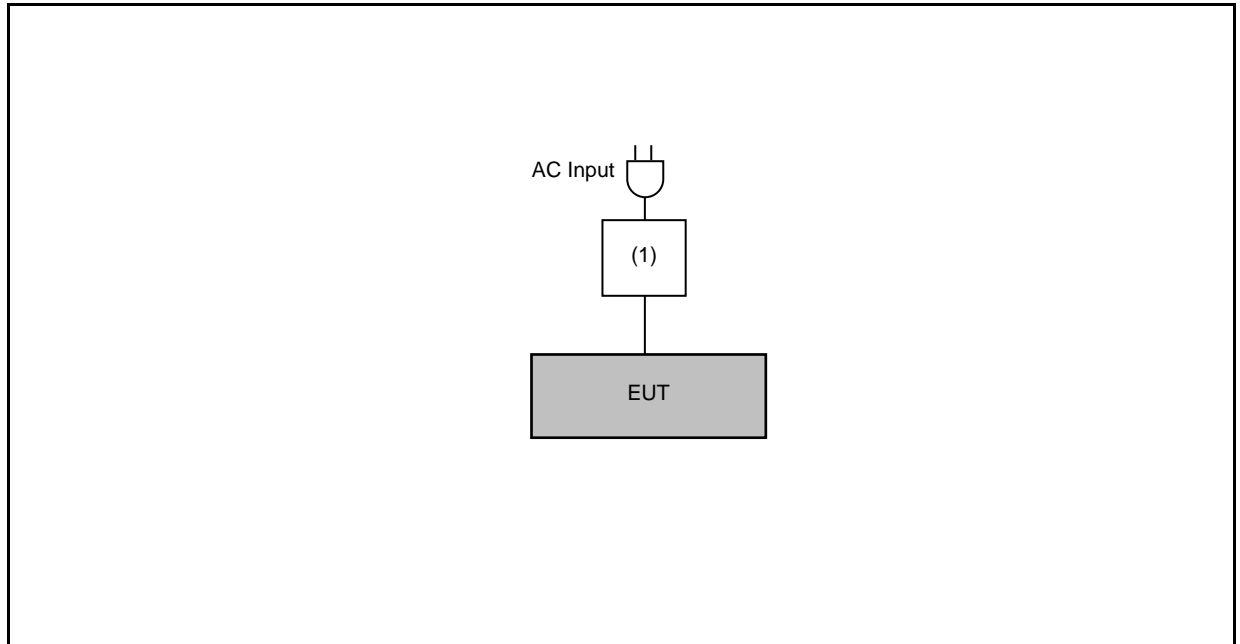

Devices Description					
	Product	Manufacturer	Model Number	Serial Number	Power Cord
(1)	AC Adapter	Keen Ocean	S09-012-0050-02000	---	---
(2)	USB Cable	ATL	TS-041-01	---	---
(3)	NB	ASUS	D1NXAS148534020	---	---

3.4. Test Instruments

For Conducted Emission

Test Period: Sep. 06, 2022

Testing Engineer: Amber Cheng

Use	Equipment	Manufacturer	Model Number	Serial Number	Cal. Date	Cal. Period
<input checked="" type="checkbox"/>	Test Receiver	R&S	ESCI	100367	May 19, 2022	1 year
<input type="checkbox"/>	Test Receiver	R&S	ESCI	100722	Nov. 02, 2021	1 year
<input type="checkbox"/>	Test Receiver	R&S	ESCI	101000	Nov. 26, 2021	1 year
<input checked="" type="checkbox"/>	LISN	R&S	ENV216	101040	Apr. 06, 2022	1 year
<input checked="" type="checkbox"/>	LISN	R&S	ENV216	101140	Jan. 25, 2022	1 year
<input checked="" type="checkbox"/>	RF Cable	Woken	00100D1380194M	TE-02-03	May 27, 2022	1 year
<input checked="" type="checkbox"/>	Software	EZ EMC	1.1.4.3	N/A	N.C.R.	---

For Conducted

Test Period: Sep. 07, 2022

Testing Engineer: Peter Shui

Use	Equipment	Manufacturer	Model Number	Serial Number	Cal. Date	Cal. Period
<input type="checkbox"/>	Spectrum Analyzer (10 Hz~26.5 GHz)	Keysight	N9010B	MY59071418	Mar. 16, 2022	1 year
<input checked="" type="checkbox"/>	Spectrum Analyzer (9 kHz~26.5 GHz)	Agilent	N9010A	MY48030518	Jul. 21, 2022	1 year
<input type="checkbox"/>	Spectrum Analyzer (3 Hz~50 GHz)	Agilent	N9030A	MY53120541	Jan. 05, 2022	1 year
<input type="checkbox"/>	Temperature & Humidity Chamber	TAICHY	MHU-225LA	980729	Mar. 28, 2022	1 year
<input type="checkbox"/>	Signal Generator	Keysight	N5182B	MY53052569	Apr. 16, 2022	1 year
<input type="checkbox"/>	Signal Generator	Keysight	N5182BX07	MY59360221	Apr. 16, 2022	1 year
<input type="checkbox"/>	Bluetooth Tester	R&S	CBT	100350	Mar. 17, 2021	2 years
<input type="checkbox"/>	Wireless Connectivity Tester	R&S	CMW270	102208	Jun. 01, 2022	1 year
<input type="checkbox"/>	Power Supply	KEITHLEY	2303	4045290	Jan. 19, 2022	1 year

Note: N.C.R. = No Calibration Request.

For Radiated Emissions
Test Period: Nov. 17, 2022
Testing Engineer: Hung Chou

Radiation test sites		Semi Anechoic Room				
Use	Equipment	Manufacturer	Model Number	Serial Number	Cal. Date	Cal. Period
<input type="checkbox"/>	Spectrum Analyzer (10 Hz~44 GHz)	Keysight	N9010A	MY52221312	Jan. 13, 2022	1 year
<input type="checkbox"/>	Spectrum Analyzer (3 Hz~50 GHz)	Agilent	N9030A	MY53120541	Jan. 05, 2022	1 year
<input type="checkbox"/>	Spectrum Analyzer (2 Hz~50 GHz)	Keysight	N9030B	MY57143537	Apr. 14, 2022	1 year
<input checked="" type="checkbox"/>	Spectrum Analyzer (10 Hz~44 GHz)	Keysight	N9020B	MY60112363	Feb. 27, 2022	1 year
<input checked="" type="checkbox"/>	Amplifier (100 kHz~1.3 GHz)	Agilent	8447D	2944A11119	Jan. 14, 2022	1 year
<input type="checkbox"/>	Amplifier (100 kHz~1.3 GHz)	Agilent	8447D	2944A10961	Jul. 07, 2022	1 year
<input type="checkbox"/>	Broadband Amplifier (100 kHz~1 GHz)	Titan	T0910E00014330 A1F	001	Jul. 21, 2022	1 year
<input type="checkbox"/>	Amplifier (1 GHz~26.5 GHz)	Agilent	8449B	3008A02237	Oct. 21, 2021	1 year
<input checked="" type="checkbox"/>	Broadband Amplifier (1 GHz~26.5 GHz)	Titan	T0912E01263025 A1F	002	Jul. 21, 2022	1 year
<input type="checkbox"/>	Preamplifier (26.5 GHz~40 GHz)	EMCI	EMC2654045	980028	Aug. 19, 2021	1 year
<input type="checkbox"/>	Loop Antenna (9 kHz~30 MHz)	COM-POWER CORPORATION	AL-130	121014	Mar. 28, 2022	1 year
<input type="checkbox"/>	Active Loop Antenna (9 kHz~30 MHz)	Schwarzbeck Mess-Elektronik	FMZB 1513-60	1513-60-031	Feb. 17, 2022	1 year
<input checked="" type="checkbox"/>	Trilog Broadband Antenna (30 kHz~1 GHz)	Schwarzbeck Mess-Elektronik	VULB9168	01146	Jul. 22, 2022	1 year
<input type="checkbox"/>	Trilog Broadband Antenna (30 kHz~1 GHz)	Schwarzbeck Mess-Elektronik	VULB9168	416	Nov. 17, 2021	1 year
<input type="checkbox"/>	Broadband Horn Antenna (1 GHz~18 GHz)	Schwarzbeck Mess-Elektronik	9120D	02207	Jul. 13, 2022	1 year
<input type="checkbox"/>	RF Cable	EMCI	EMC104-N-N-6000	TE01-1	Feb. 18, 2022	1 year
<input type="checkbox"/>	Microwave Cable	EMCI	EMC104-SM-SM-13000	170814	Feb. 18, 2022	1 year
<input type="checkbox"/>	Microwave Cable	EMCI	EMC102-KM-KM-14000	151001	Feb. 18, 2022	1 year

Note: N.C.R. = No Calibration Request.

Radiation test sites		Semi Anechoic Room				
Use	Equipment	Manufacturer	Model Number	Serial Number	Cal. Date	Cal. Period
<input checked="" type="checkbox"/>	Coaxial Cable	Titan	T0710AT327A10A 100	J11005	Aug. 04, 2022	1 year
<input checked="" type="checkbox"/>	Coaxial Cable	Titan	T0710AT327A10A 900	J11004	Aug. 04, 2022	1 year
<input checked="" type="checkbox"/>	Coaxial Cable	Titan	CFD400NL-LW	001	Aug. 04, 2022	1 year
<input type="checkbox"/>	Bluetooth Tester	R&S	CBT	100350	Mar. 17, 2021	2 years
<input type="checkbox"/>	Wireless Connectivity Tester	R&S	CMW270	102208	Jun. 01, 2022	1 year
<input type="checkbox"/>	Power Supply	KEITHLEY	2303	4045290	Jan. 19, 2022	1 year
<input checked="" type="checkbox"/>	Software	EZ EMC	1.1.4.4	N/A	N.C.R.	---

Note: N.C.R. = No Calibration Request.

3.5. Test Site Environment

Items	Required (IEC 60068-1)	Actual
Temperature (°C)	15-35	20-30
Humidity (%RH)	25-75	45-75

4 Measurement Procedure

4.1. AC Power Line Conducted Emission Measurement

■ Limit

Frequency (MHz)	Quasi-peak	Average
0.15 - 0.5	66 to 56	56 to 46
0.50 - 5.0	56	46
5.0 - 30.0	60	50

■ Test Setup

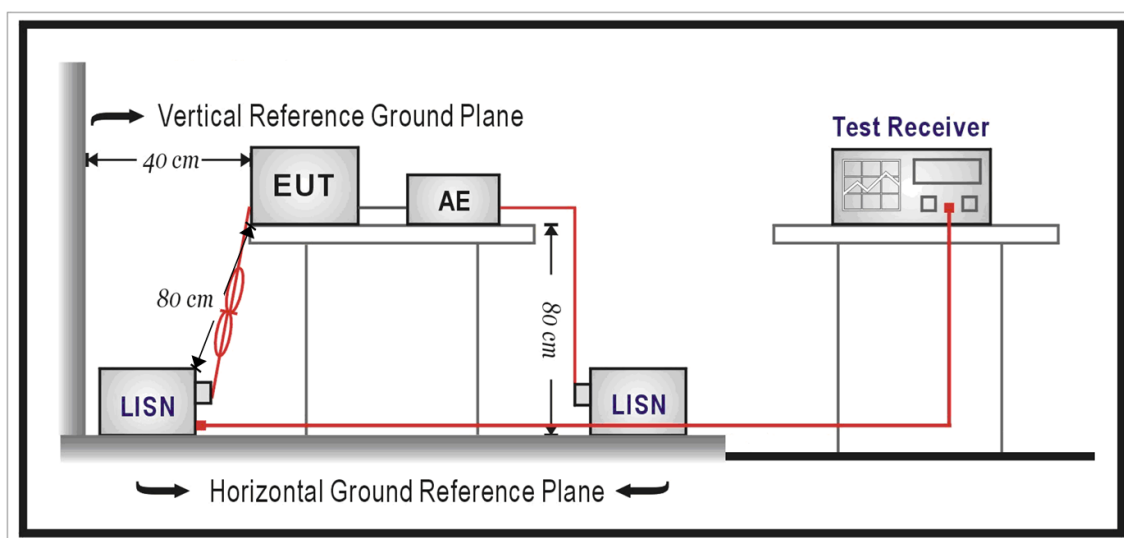

■ Test Procedure

The EUT and simulators are connected to the main power through a line impedance stabilization network (L.I.S.N.). This provides a $50 \Omega // 50 \mu\text{H}$ coupling impedance for the measuring equipment. The peripheral devices are also connected to the main power through a LISN that provides a $50 \Omega // 50 \mu\text{H}$ coupling impedance with 50 ohm termination.

Tabletop device shall be placed on a non-conducting platform, of nominal size 1 m by 1.5 m, raised 80 cm above the reference ground plane. The wall of screened room shall be located 40 cm to the rear of the EUT. Other surfaces of tabletop or floor standing EUT shall be at least 80 cm from any other ground conducting surface including one or more LISNs. For floor-standing device shall be placed under the EUT with a 12 mm insulating material.

Conducted emissions were investigated over the frequency range from 0.15 MHz to 30 MHz using a resolution bandwidth of 9 kHz. The equipment under test (EUT) shall be meet the limits in section 4.1, as applicable, including the average limit and the quasi-peak limit when using respectively, an average detector and quasi-peak detector measured in accordance with the methods described of related standard. When all of peak value were complied with quasi-peak and average limit from 150 kHz to 30 MHz then quasi-peak and average measurement was unnecessary.

The AMN shall be placed 0.8 m from the boundary of the unit under test and bonded to a ground reference plane for AMNs mounted on top of the ground reference plane. This distance is between the closest points of the AMN and the EUT. All other units of the EUT and associated equipment shall be at least 0.8 m from the AMN. If the mains power cable is longer than 1 m then the cable shall be folded back and forth at the centre of the lead to form a bundle no longer than 0.4 m. All of interconnecting cables that hang closer than 40 cm to the ground plane shall be folded back and forth in the center forming a bundle 30 cm to 40 cm long. All of EUT and AE shall be separate place more than 0.1 m. All 50Ω ports of the LISN shall be resistively terminated into 50Ω loads when not connected to the measuring instrument.

If the reading of the measuring receiver shows fluctuations close to the limit, the reading shall be observed for at least 15 s at each measurement frequency; the higher reading shall be recorded with the exception of any brief isolated high reading which shall be ignored..

4.2. Radiated Emission Measurement

■ Limit

According to §15.231 (e) Intentional radiators may operate at a periodic rate exceeding that specified in paragraph (a) of this section and may be employed for any type of operation, including operation prohibited in paragraph (a) of this section, provided the intentional radiator complies with the provisions of paragraphs (b) through (d) of this section, except the field strength table in paragraph (b) of this section is replaced by the following: Linear interpolations.

Fundamental frequency (MHz)	Field strength of fundamental (microvolts/meter)	Field strength of spurious emission (microvolts/meter)
40.66-40.70	1,000	100
70-130	500	50
130-174	500 to 1,500 ¹	50 to 150 ¹
174-260	1,500	150
260-470	1,500 to 5,000 ¹	150 to 500 ¹
Above 470	5,000	500

■ Setup

9 kHz ~ 30 MHz

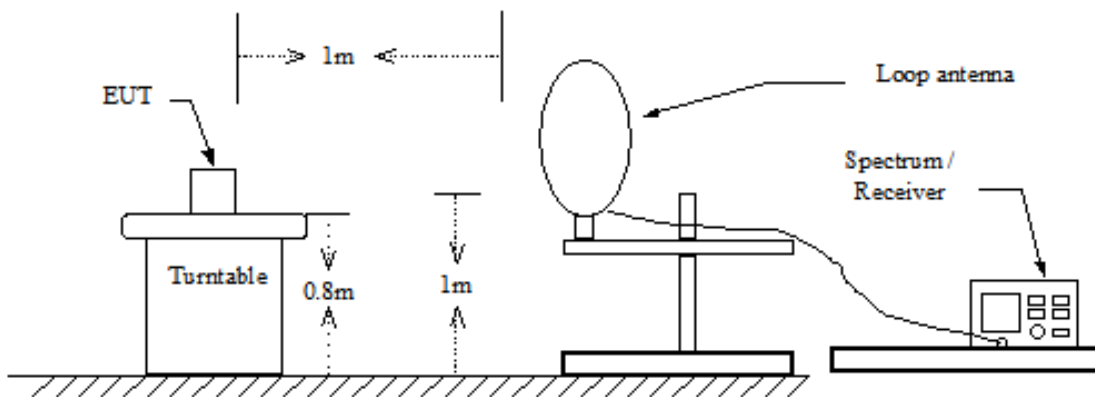

Below 1 GHz

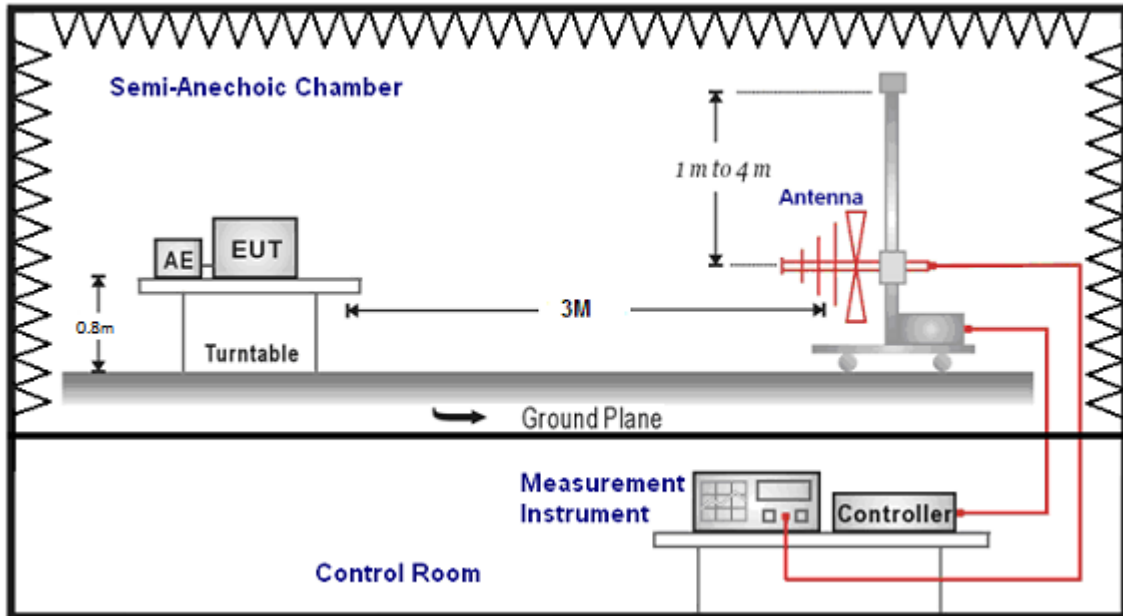

Above 1 GHz

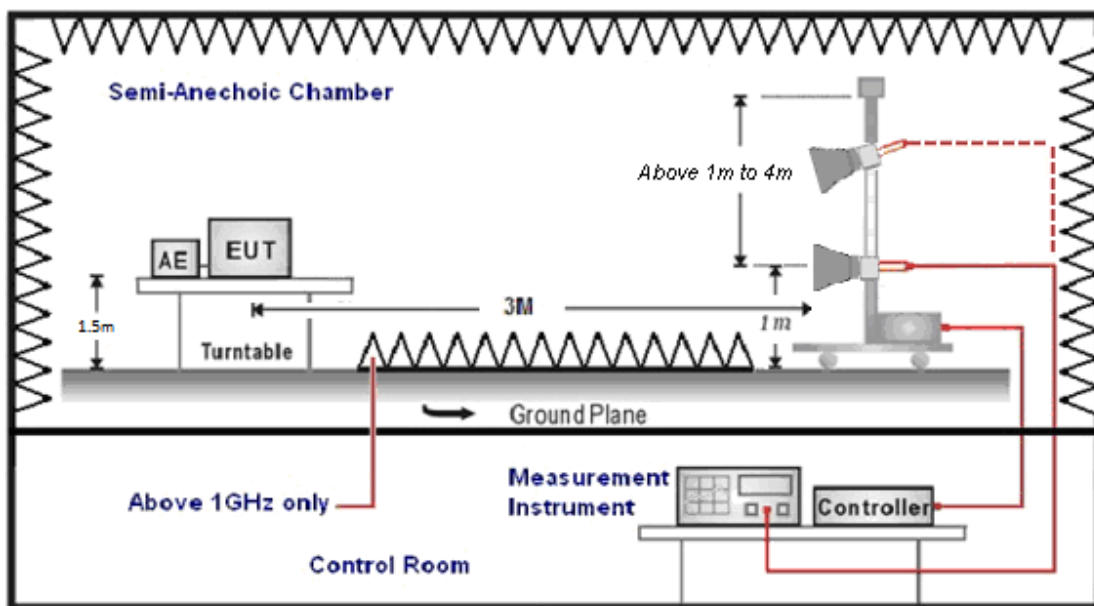

■ Test Procedure

Final radiation measurements were made on a three-meter, Semi Anechoic Chamber. The EUT system was placed on a nonconductive turntable which is 0.8 or 1.5 meters height, top surface 1.0 x 1.5 meter. The spectrum was examined from 250 MHz to 2.5 GHz in order to cover the whole spectrum below 10th harmonic which could generate from the EUT. During the test, EUT was set to transmit continuously & Measurements spectrum range from 9 kHz to 26.5 GHz is investigated.

For measurements below 1 GHz the resolution bandwidth is set to 100 kHz for peak detection measurements or 120 kHz for quasi-peak detection measurements. Peak detection is used unless otherwise noted as quasi-peak.

For measurements above 1 GHz the resolution bandwidth is set to 1 MHz, and then the video bandwidth is set to 3 MHz for peak measurements and 10 Hz for average measurements when Duty cycle >98 % / 1/T for average measurements when Duty cycle <98 %. A nonconductive material surrounded the EUT to supporting the EUT for standing on three orthogonal planes. At each condition, the EUT was rotated 360 degrees, and the antenna was raised and lowered from one to four meters to find the maximum emission levels. Measurements were taken using both horizontal and vertical antenna polarization.

SCHWARZBECK MESS-ELEKTRONIK Biconilog Antenna at 3 Meter and the SCHWARZBECK Double Ridged Guide Antenna was used in frequencies 1 – 26.5 GHz at a distance of 1 meter. All test results were extrapolated to equivalent signal at 3 meters utilizing an inverse linear distance extrapolation Factor (20 dB/decade).

For testing above 1 GHz, the emission level of the EUT in peak mode was 20 dB lower than average limit (that means the emission level in peak mode also complies with the limit in average mode), then testing will be stopped and peak values of EUT will be reported, otherwise, the emissions will be measured in average mode again and reported.

Appropriate preamplifiers were used for improving sensitivity and precautions were taken to avoid overloading or desensitizing the spectrum analyzer. No post – detector video filters were used in the test.

The spectrum analyzer's 6 dB bandwidth was set to 1 MHz, and the analyzer was operated in the peak detection mode, for frequencies both below and up 1 GHz. The average levels were obtained by subtracting the duty cycle correction factor from the peak readings.

The following procedures were used to convert the emission levels measured in decibels referenced to 1 microvolt (dBuV) into field intensity in micro volts pre meter (uV/m).

The actual field intensity in decibels referenced to 1 microvolt in to field intensity in micro volts per meter (dBuV/m).

The actual field intensity in referenced to 1 microvolt per meter (dBuV/m) is determined by algebraically adding the measured reading in dBuV, the antenna factor (dB), and cable loss (dB) and Subtracting the gain of preamplifier (dB) is auto calculate in spectrum analyzer.

(1) Correction factor (dBuV/m) = FI (dBuV) +AF (dBuV) +CL (dBuV)-Gain (dB)

FI= Reading of the field intensity.

AF= Antenna factor.

CL= Cable loss.

P.S Amplitude is auto calculate in spectrum analyzer.

(2) Result (dBuV/m) = Correction factor (dB/m) + Reading(dBuV).

(3) Actual Amplitude (dBuV/m) = Amplitude (dBuV)-Dis(dB)

The FCC specified emission limits were calculated according the EUT operating frequency and by following linear interpolation equations:

(a) For fundamental frequency : Transmitter Output < +30 dBm

(b) For spurious frequency : Spurious emission limits = fundamental emission limit /10

Data of measurement within this frequency range without mark in the table above means the reading of emissions are attenuated more than 20 dB below the permissible limits or the field strength is too small to be measured.

When peak results are less than average limit, so not need to evaluate the average.

4.3. Duration of transmission

■ Limit

In addition, devices operated under the provisions of this paragraph shall be provided with a means for automatically limiting operation so that the duration of each transmission shall not be greater than one second and the silent period between transmissions shall be at least 30 times the duration of the transmission but in no case less than 10 seconds.

■ Test Setup

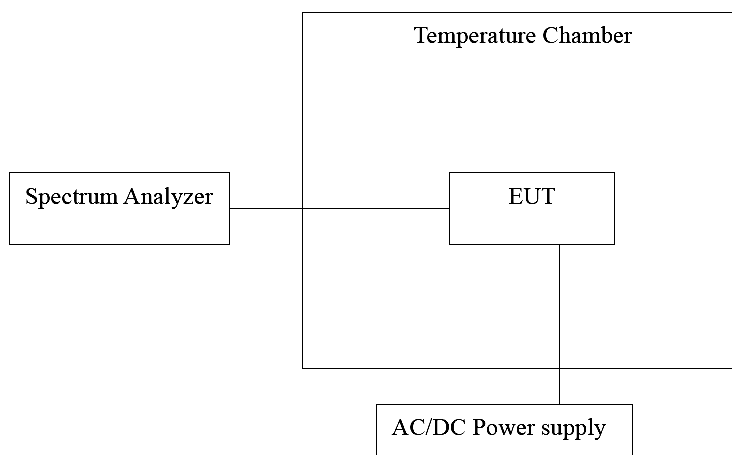

■ Test Procedure

1. Place the EUT on the table and set it in the transmitting mode.
2. Remove the antenna from the EUT and then connect a low loss RF cable from the antenna port to the spectrum analyzer.
3. Set the environment into appropriate environment.
4. Set the spectrum analyzer as RBW=100 kHz, VBW = RBW, Span = 0 Hz, Sweep = 12 S.
5. Mark the peak frequency and measure the frequency tolerance using frequency counter function.
6. Repeat until all the results are investigated.

4.4. Bandwidth measurement

■ Limit

According to §15.231 (c) The bandwidth of the emission shall be no wider than 0.25 % of the center frequency for devices operating above 70 MHz and below 900 MHz. For devices operating above 900 MHz, the emission shall be no wider than 0.5 % of the center frequency. Bandwidth is determined at the points 20 dB down from the modulated carrier.

■ Test Setup

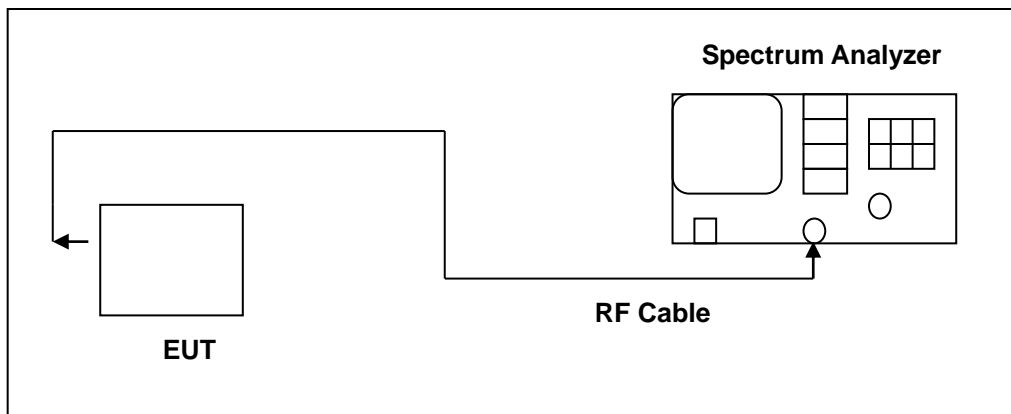

■ Test Procedure

1. Place the EUT on the table and set it in the transmitting mode.
2. Remove the antenna from the EUT and then connect a low loss RF cable from the antenna port to the spectrum analyzer.
3. Set the environment into appropriate environment.
4. Set the spectrum analyzer as RBW = 10 kHz, VBW = 30 kHz, Span = 1 MHz, Sweep = 12.4 ms.
5. Mark the peak frequency and measure the frequency tolerance using frequency counter function.
6. Repeat until all the results are investigated.

4.5. Antenna Requirement

■ Limit

For intentional device, according to 15.203, an intentional radiator shall be designed to ensure that no antenna other than that furnished by the responsible party shall be used with the device.

■ Antenna Connector Construction

See section 2 – antenna information.

5 Test Results

5.1. Conducted Emission

Standard:	FCC Part 15.231	Line:	L1
Test item:	Conducted Emission	Power:	AC 120 V/60 Hz
Mode:	Transmit Mode		
Description:			

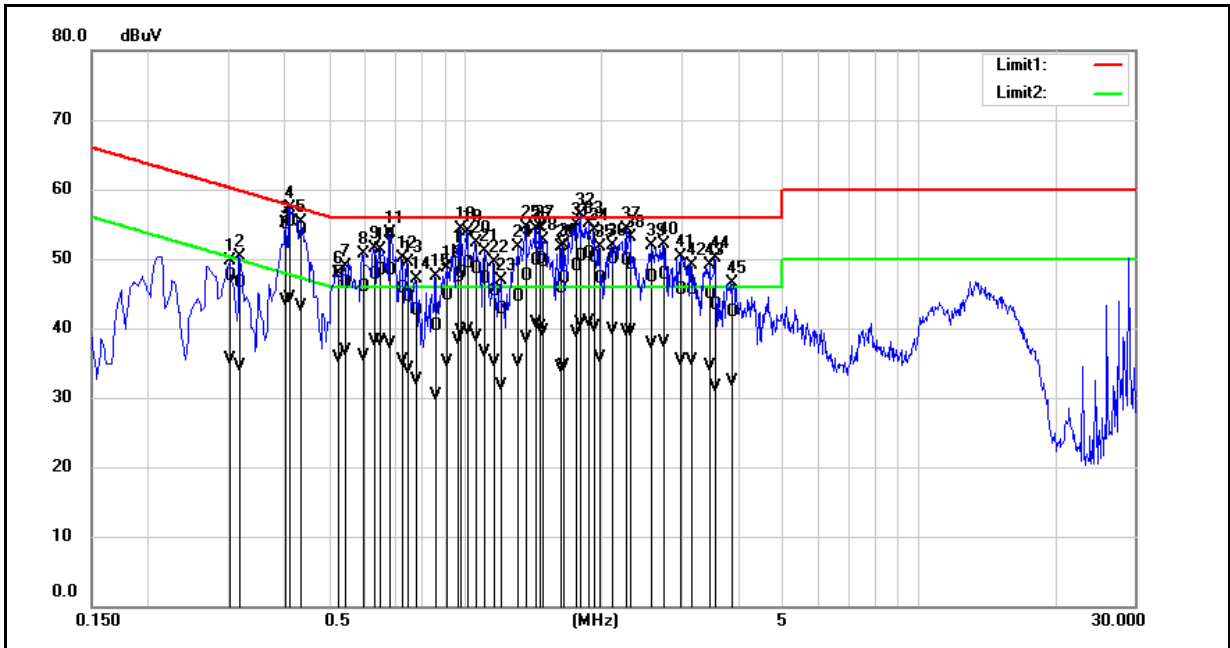

Standard:	FCC Part 15.231	Line:	L1
Test item:	Conducted Emission	Power:	AC 120 V/60 Hz
Mode:	Transmit Mode		
Description:			

No.	Frequency (MHz)	QP reading (dBuV)	AVG reading (dBuV)	Correction factor (dB)	QP result (dBuV)	AVG result (dBuV)	QP limit (dBuV)	AVG limit (dBuV)	QP margin (dB)	AVG margin (dB)	Remark
1	0.3020	37.96	25.92	9.54	47.50	35.46	60.19	50.19	-12.69	-14.73	Pass
2	0.3180	36.89	24.95	9.54	46.43	34.49	59.76	49.76	-13.33	-15.27	Pass
3	0.4020	45.38	34.45	9.55	54.93	44.00	57.81	47.81	-2.88	-3.81	Pass
4	0.4100	45.82	34.70	9.55	55.37	44.25	57.65	47.65	-2.28	-3.40	Pass
5	0.4340	44.58	33.61	9.55	54.13	43.16	57.18	47.18	-3.05	-4.02	Pass
6	0.5220	38.43	26.07	9.55	47.98	35.62	56.00	46.00	-8.02	-10.38	Pass
7	0.5420	36.99	27.13	9.55	46.54	36.68	56.00	46.00	-9.46	-9.32	Pass
8	0.5940	36.35	26.39	9.55	45.90	35.94	56.00	46.00	-10.10	-10.06	Pass
9	0.6300	38.07	28.49	9.56	47.63	38.05	56.00	46.00	-8.37	-7.95	Pass
10	0.6500	38.65	28.62	9.56	48.21	38.18	56.00	46.00	-7.79	-7.82	Pass
11	0.6820	38.74	28.20	9.56	48.30	37.76	56.00	46.00	-7.70	-8.24	Pass
12	0.7260	36.17	25.73	9.57	45.74	35.30	56.00	46.00	-10.26	-10.70	Pass
13	0.7460	34.94	24.45	9.57	44.51	34.02	56.00	46.00	-11.49	-11.98	Pass
14	0.7780	32.89	23.02	9.57	42.46	32.59	56.00	46.00	-13.54	-13.41	Pass
15	0.8580	30.66	20.72	9.57	40.23	30.29	56.00	46.00	-15.77	-15.71	Pass
16	0.9140	35.16	25.48	9.58	44.74	35.06	56.00	46.00	-11.26	-10.94	Pass
17	0.9620	37.77	28.63	9.58	47.35	38.21	56.00	46.00	-8.65	-7.79	Pass
18	0.9780	38.41	29.87	9.58	47.99	39.45	56.00	46.00	-8.01	-6.55	Pass
19	1.0060	39.74	30.15	9.58	49.32	39.73	56.00	46.00	-6.68	-6.27	Pass
20	1.0540	38.96	29.15	9.58	48.54	38.73	56.00	46.00	-7.46	-7.27	Pass
21	1.1060	37.48	26.93	9.58	47.06	36.51	56.00	46.00	-8.94	-9.49	Pass
22	1.1580	35.67	25.45	9.58	45.25	35.03	56.00	46.00	-10.75	-10.97	Pass
23	1.2020	33.04	22.07	9.59	42.63	31.66	56.00	46.00	-13.37	-14.34	Pass

Note: 1. Result (dBuV) = Correction factor (dB) + Reading(dBuV).

2. Correction factor (dB) = Cable loss (dB) + L.I.S.N. factor (dB).

Standard:	FCC Part 15.231	Line:	L1
Test item:	Conducted Emission	Power:	AC 120 V/60 Hz
Mode:	Transmit Mode		
Description:			

No.	Frequency (MHz)	QP reading (dBuV)	AVG reading (dBuV)	Correction factor (dB)	QP result (dBuV)	AVG result (dBuV)	QP limit (dBuV)	AVG limit (dBuV)	QP margin (dB)	AVG margin (dB)	Remark
24	1.3060	34.90	25.54	9.59	44.49	35.13	56.00	46.00	-11.51	-10.87	Pass
25	1.3540	37.92	28.84	9.59	47.51	38.43	56.00	46.00	-8.49	-7.57	Pass
26	1.4300	40.15	31.08	9.59	49.74	40.67	56.00	46.00	-6.26	-5.33	Pass
27	1.4620	40.36	30.51	9.59	49.95	40.10	56.00	46.00	-6.05	-5.90	Pass
28	1.4780	39.97	29.95	9.59	49.56	39.54	56.00	46.00	-6.44	-6.46	Pass
29	1.6220	36.17	24.76	9.60	45.77	34.36	56.00	46.00	-10.23	-11.64	Pass
30	1.6380	37.52	24.85	9.60	47.12	34.45	56.00	46.00	-8.88	-11.55	Pass
31	1.7580	39.25	29.61	9.60	48.85	39.21	56.00	46.00	-7.15	-6.79	Pass
32	1.7980	40.74	31.02	9.60	50.34	40.62	56.00	46.00	-5.66	-5.38	Pass
33	1.8740	41.08	31.31	9.61	50.69	40.92	56.00	46.00	-5.31	-5.08	Pass
34	1.9220	40.52	30.40	9.61	50.13	40.01	56.00	46.00	-5.87	-5.99	Pass
35	1.9780	37.44	26.05	9.61	47.05	35.66	56.00	46.00	-8.95	-10.34	Pass
36	2.1020	40.29	30.07	9.61	49.90	39.68	56.00	46.00	-6.10	-6.32	Pass
37	2.2660	40.07	29.96	9.62	49.69	39.58	56.00	46.00	-6.31	-6.42	Pass
38	2.3140	39.54	29.98	9.62	49.16	39.60	56.00	46.00	-6.84	-6.40	Pass
39	2.5780	37.74	28.13	9.63	47.37	37.76	56.00	46.00	-8.63	-8.24	Pass
40	2.7260	38.00	28.34	9.63	47.63	37.97	56.00	46.00	-8.37	-8.03	Pass
41	2.9780	35.83	25.76	9.64	45.47	35.40	56.00	46.00	-10.53	-10.60	Pass
42	3.1420	35.81	25.65	9.64	45.45	35.29	56.00	46.00	-10.55	-10.71	Pass
43	3.4540	35.19	24.94	9.65	44.84	34.59	56.00	46.00	-11.16	-11.41	Pass
44	3.5620	33.64	21.91	9.66	43.30	31.57	56.00	46.00	-12.70	-14.43	Pass
45	3.8620	32.57	22.56	9.67	42.24	32.23	56.00	46.00	-13.76	-13.77	Pass

Note: 1. Result (dBuV) = Correction factor (dB) + Reading(dBuV).
2. Correction factor (dB) = Cable loss (dB) + L.I.S.N. factor (dB).

Standard:	FCC Part 15.231	Line:	N
Test item:	Conducted Emission	Power:	AC 120 V/60 Hz
Mode:	Transmit Mode		
Description:			

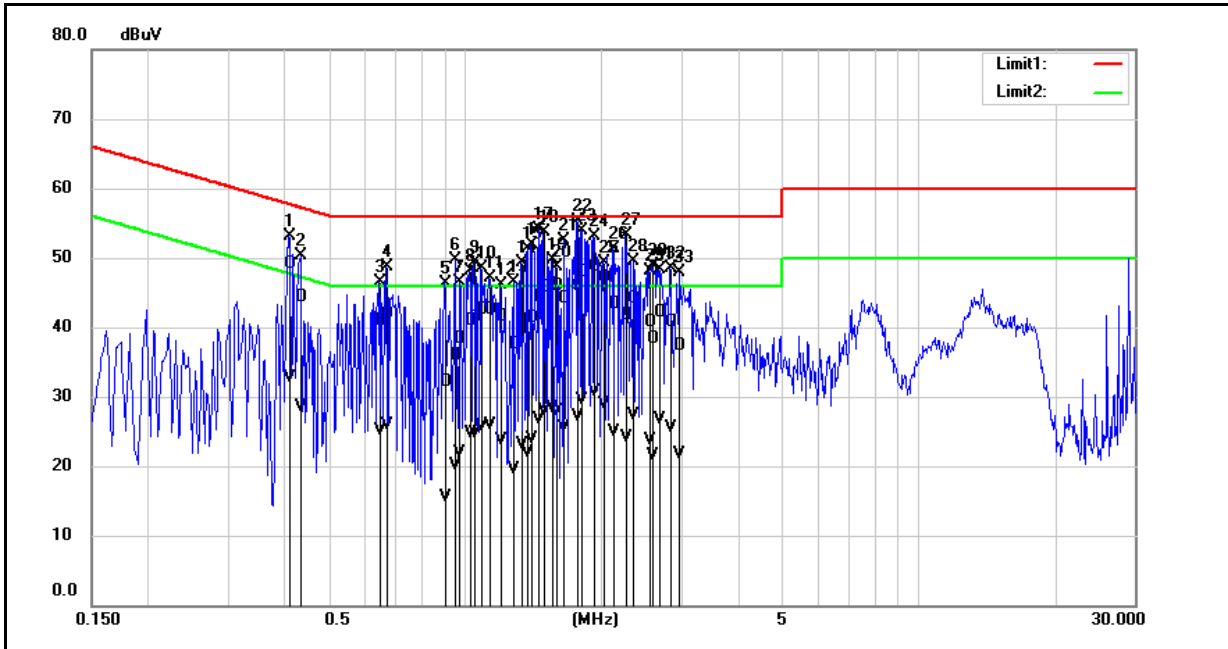

Standard:	FCC Part 15.231	Line:	N
Test item:	Conducted Emission	Power:	AC 120 V/60 Hz
Mode:	Transmit Mode		
Description:			

No.	Frequency (MHz)	QP reading (dBuV)	AVG reading (dBuV)	Correction factor (dB)	QP result (dBuV)	AVG result (dBuV)	QP limit (dBuV)	AVG limit (dBuV)	QP margin (dB)	AVG margin (dB)	Remark
1	0.4100	39.49	23.13	9.61	49.10	32.74	57.65	47.65	-8.55	-14.91	Pass
2	0.4340	34.76	18.98	9.61	44.37	28.59	57.18	47.18	-12.81	-18.59	Pass
3	0.6460	31.32	15.57	9.62	40.94	25.19	56.00	46.00	-15.06	-20.81	Pass
4	0.6700	32.37	16.21	9.62	41.99	25.83	56.00	46.00	-14.01	-20.17	Pass
5	0.9020	22.38	5.95	9.64	32.02	15.59	56.00	46.00	-23.98	-30.41	Pass
6	0.9500	26.31	10.43	9.64	35.95	20.07	56.00	46.00	-20.05	-25.93	Pass
7	0.9740	28.65	12.24	9.64	38.29	21.88	56.00	46.00	-17.71	-24.12	Pass
8	1.0220	31.21	14.97	9.64	40.85	24.61	56.00	46.00	-15.15	-21.39	Pass
9	1.0460	31.74	15.14	9.64	41.38	24.78	56.00	46.00	-14.62	-21.22	Pass
10	1.0860	32.78	16.02	9.64	42.42	25.66	56.00	46.00	-13.58	-20.34	Pass
11	1.1340	32.81	16.31	9.64	42.45	25.95	56.00	46.00	-13.55	-20.05	Pass
12	1.1940	31.91	14.02	9.65	41.56	23.67	56.00	46.00	-14.44	-22.33	Pass
13	1.2820	27.84	9.87	9.65	37.49	19.52	56.00	46.00	-18.51	-26.48	Pass
14	1.3260	31.33	13.43	9.65	40.98	23.08	56.00	46.00	-15.02	-22.92	Pass
15	1.3740	30.07	12.35	9.65	39.72	22.00	56.00	46.00	-16.28	-24.00	Pass
16	1.4020	31.74	14.27	9.65	41.39	23.92	56.00	46.00	-14.61	-22.08	Pass
17	1.4500	34.62	17.09	9.65	44.27	26.74	56.00	46.00	-11.73	-19.26	Pass
18	1.4900	35.97	18.30	9.65	45.62	27.95	56.00	46.00	-10.38	-18.05	Pass
19	1.5580	36.40	18.62	9.67	46.07	28.29	56.00	46.00	-9.93	-17.71	Pass
20	1.5860	36.20	18.27	9.67	45.87	27.94	56.00	46.00	-10.13	-18.06	Pass

Note: 1. Result (dBuV) = Correction factor (dB) + Reading(dBuV).

2. Correction factor (dB) = Cable loss (dB) + L.I.S.N. factor (dB).

Standard:	FCC Part 15.231	Line:	N
Test item:	Conducted Emission	Power:	AC 120 V/60 Hz
Mode:	Transmit Mode		
Description:			

No.	Frequency (MHz)	QP reading (dBuV)	AVG reading (dBuV)	Correction factor (dB)	QP result (dBuV)	AVG result (dBuV)	QP limit (dBuV)	AVG limit (dBuV)	QP margin (dB)	AVG margin (dB)	Remark
21	1.6540	34.36	15.86	9.67	44.03	25.53	56.00	46.00	-11.97	-20.47	Pass
22	1.7700	36.30	17.53	9.67	45.97	27.20	56.00	46.00	-10.03	-18.80	Pass
23	1.8100	38.31	19.81	9.67	47.98	29.48	56.00	46.00	-8.02	-16.52	Pass
24	1.9260	39.06	20.93	9.68	48.74	30.61	56.00	46.00	-7.26	-15.39	Pass
25	2.0220	37.42	19.25	9.68	47.10	28.93	56.00	46.00	-8.90	-17.07	Pass
26	2.1180	33.70	15.24	9.68	43.38	24.92	56.00	46.00	-12.62	-21.08	Pass
27	2.2500	32.06	14.40	9.69	41.75	24.09	56.00	46.00	-14.25	-21.91	Pass
28	2.3460	34.41	17.58	9.69	44.10	27.27	56.00	46.00	-11.90	-18.73	Pass
29	2.5420	30.96	14.07	9.69	40.65	23.76	56.00	46.00	-15.35	-22.24	Pass
30	2.5940	28.70	11.86	9.69	38.39	21.55	56.00	46.00	-17.61	-24.45	Pass
31	2.6740	32.37	16.98	9.69	42.06	26.67	56.00	46.00	-13.94	-19.33	Pass
32	2.8260	30.97	15.71	9.70	40.67	25.41	56.00	46.00	-15.33	-20.59	Pass
33	2.9620	27.65	11.94	9.70	37.35	21.64	56.00	46.00	-18.65	-24.36	Pass

Note: 1. Result (dBuV) = Correction factor (dB) + Reading(dBuV).

2. Correction factor (dB) = Cable loss (dB) + L.I.S.N. factor (dB).

5.2. Conducted Test Results

Duration of transmission

Test Mode	RFID			
Frequency (MHz)	Duration Time		Silent Time	
	Results (ms)	Limit (s)	Results (ms)	Limit (s)
433.9163	680	≤ 1	Pass	≥ 20.4

Note:1. Duration time=total sum tx on time is 680 ms

2. Silent Time Limit (s) = 30 * Duration Time (ms) = 30 * 680 (ms) = 20.4 (s)

■ Test Graphs

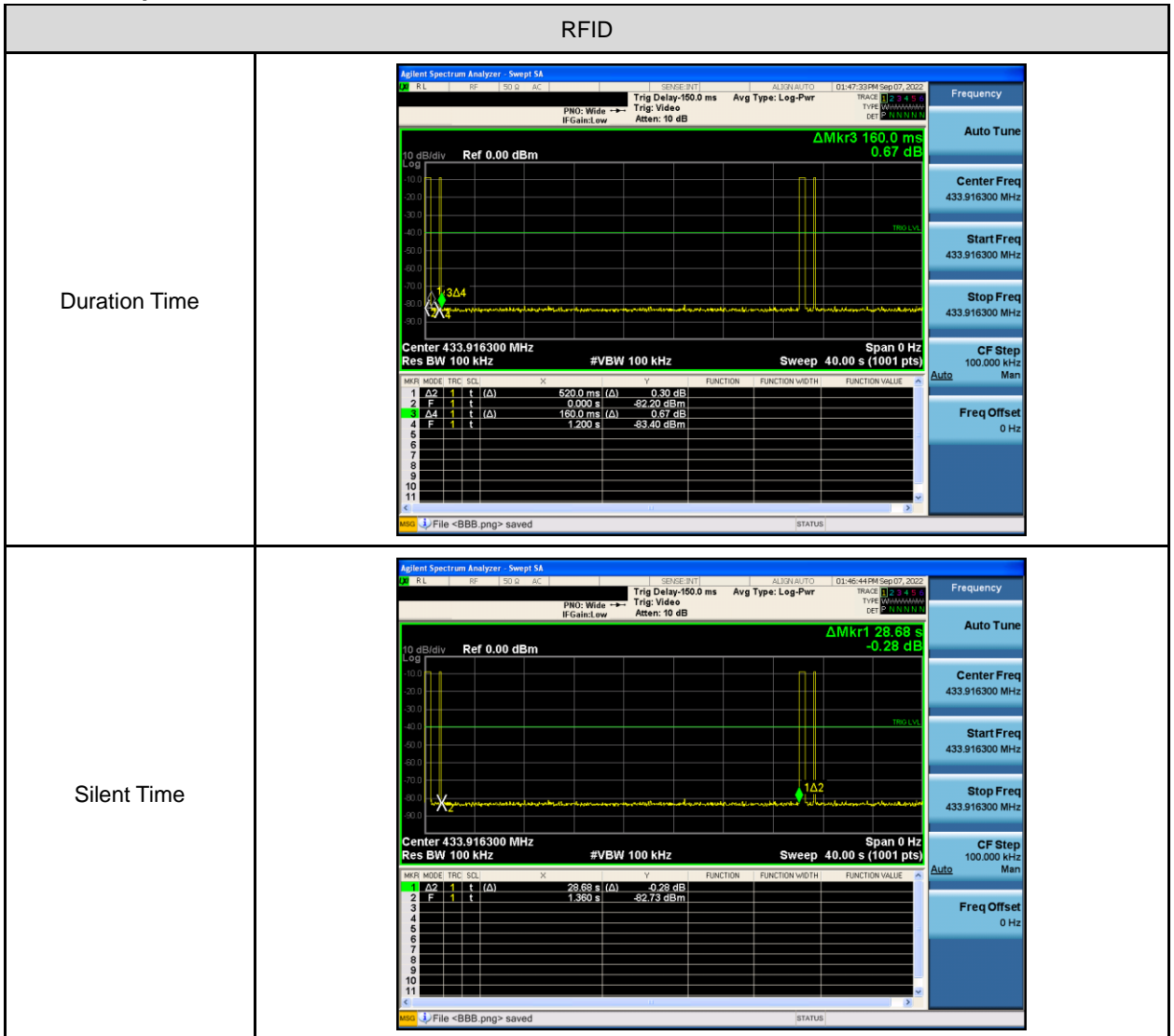

Bandwidth measurement

Test Mode	RFID		
Frequency (MHz)	Bandwidth Emission (kHz)	Limit (kHz)	Result
433.9163	6.242	1084.79075	Pass

■ **Test Graphs**

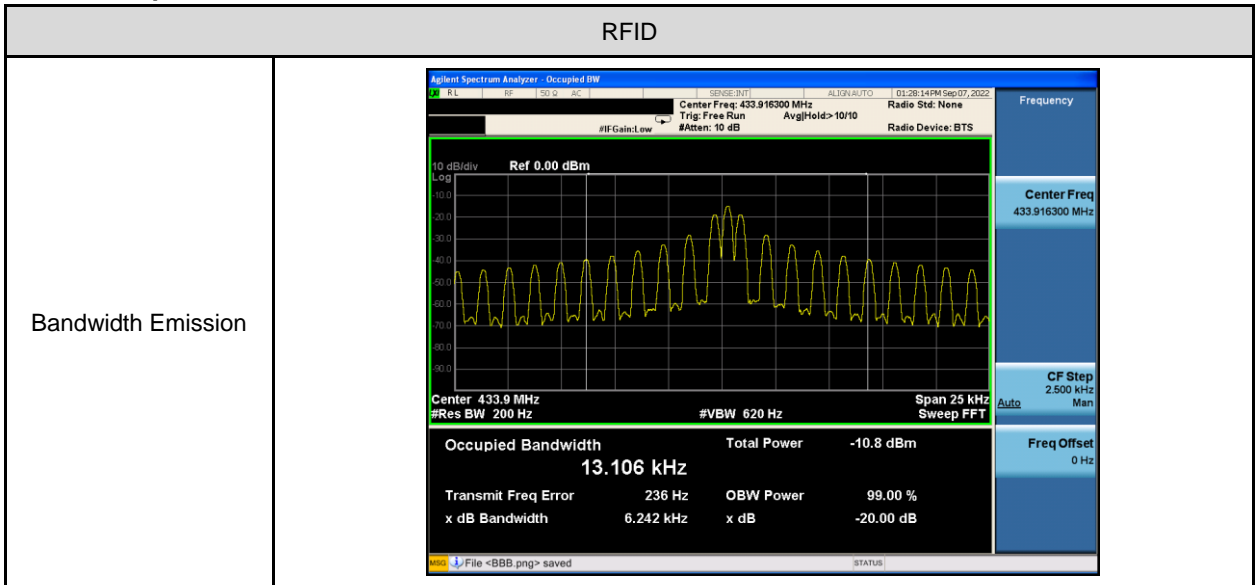

5.3. Radiated Emission Measurement

Fundamental

Standard:	FCC Part 15.231	Test Distance:	3 m
Test item:	Fundamental		
Mode:	RFID		
Ant.Polar.:	Horizontal		

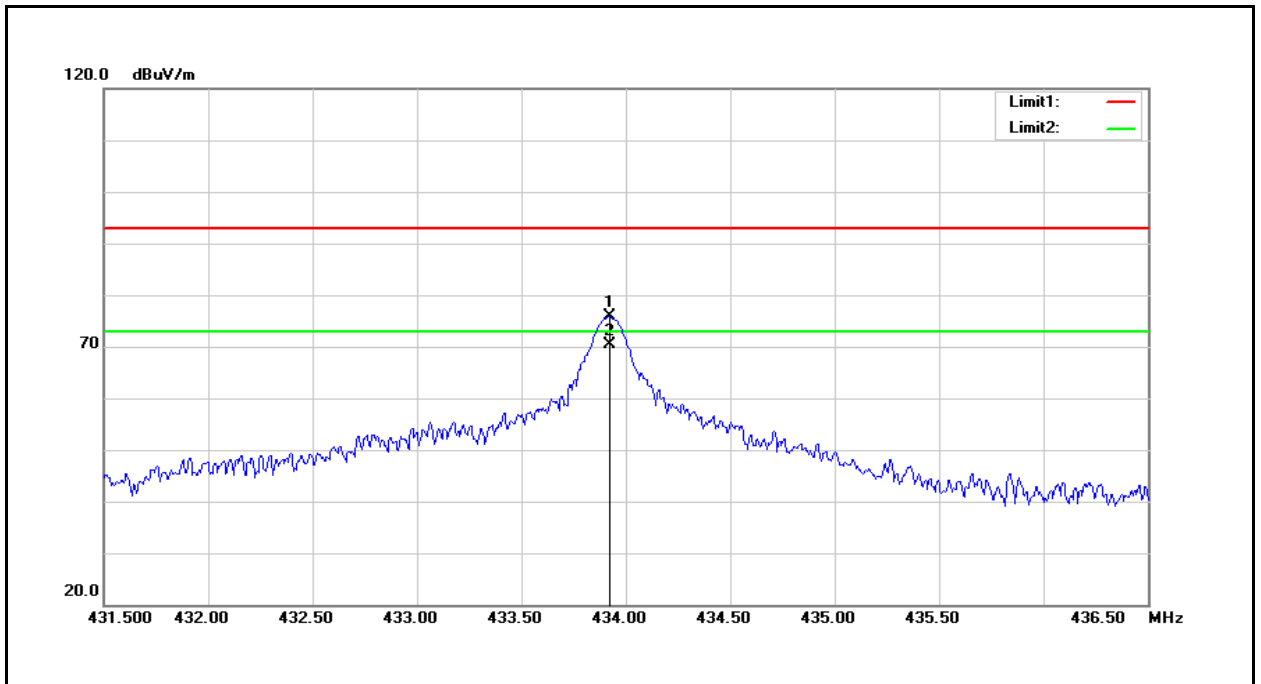

No.	Frequency (MHz)	Reading (dBuV)	Correct Factor (dB/m)	Result (dBuV/m)	Limit (dBuV/m)	Margin (dB)	Remark
1	433.9200	78.72	-2.94	75.78	92.87	-17.09	peak
2*	433.9200	73.27	-2.94	70.33	72.87	-2.54	AVG

Standard:	FCC Part 15.231	Test Distance:	3 m
Test item:	Fundamental		
Mode:	RFID		
Ant.Polar.:	Vertical		

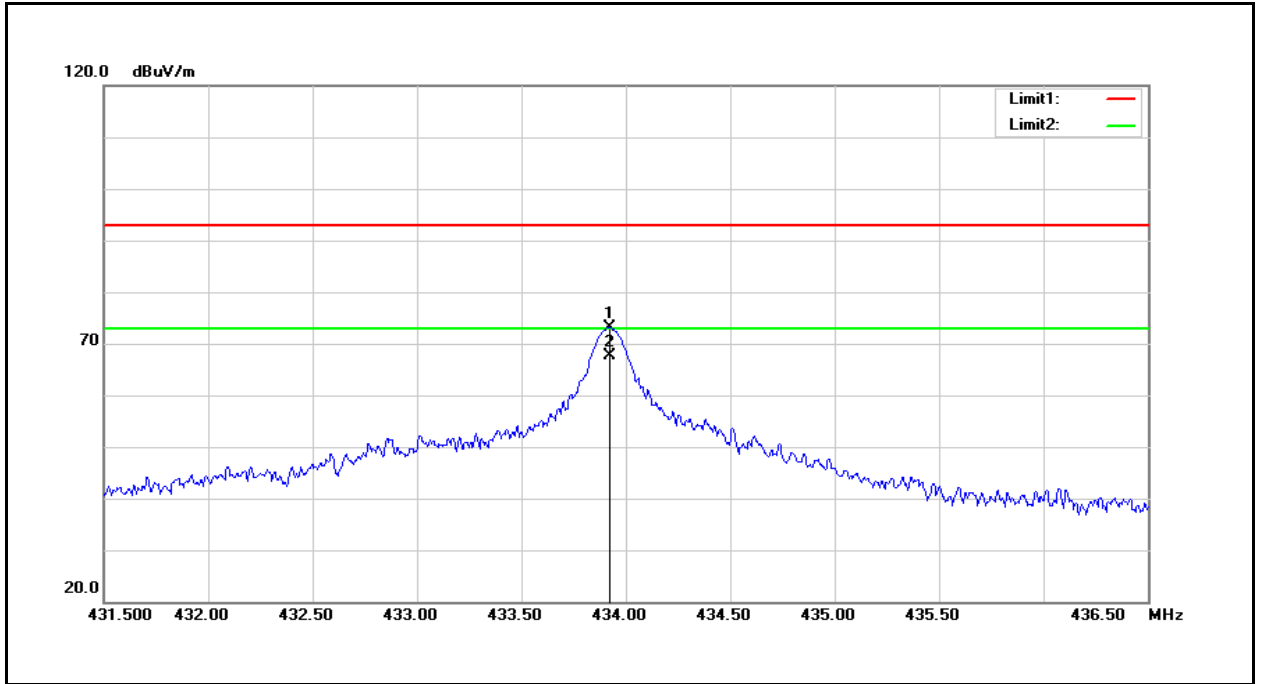

No.	Frequency (MHz)	Reading (dBuV)	Correct Factor (dB/m)	Result (dBuV/m)	Limit (dBuV/m)	Margin (dB)	Remark
1	433.9200	76.00	-2.94	73.06	92.87	-19.81	peak
2*	433.9200	70.55	-2.94	67.61	72.87	-5.26	AVG

Below 1 GHz

Standard:	FCC Part 15.231	Test Distance:	3 m
Test item:	Radiated Emission		
Mode:	Transmit Mode		
Ant.Polar.:	Horizontal		

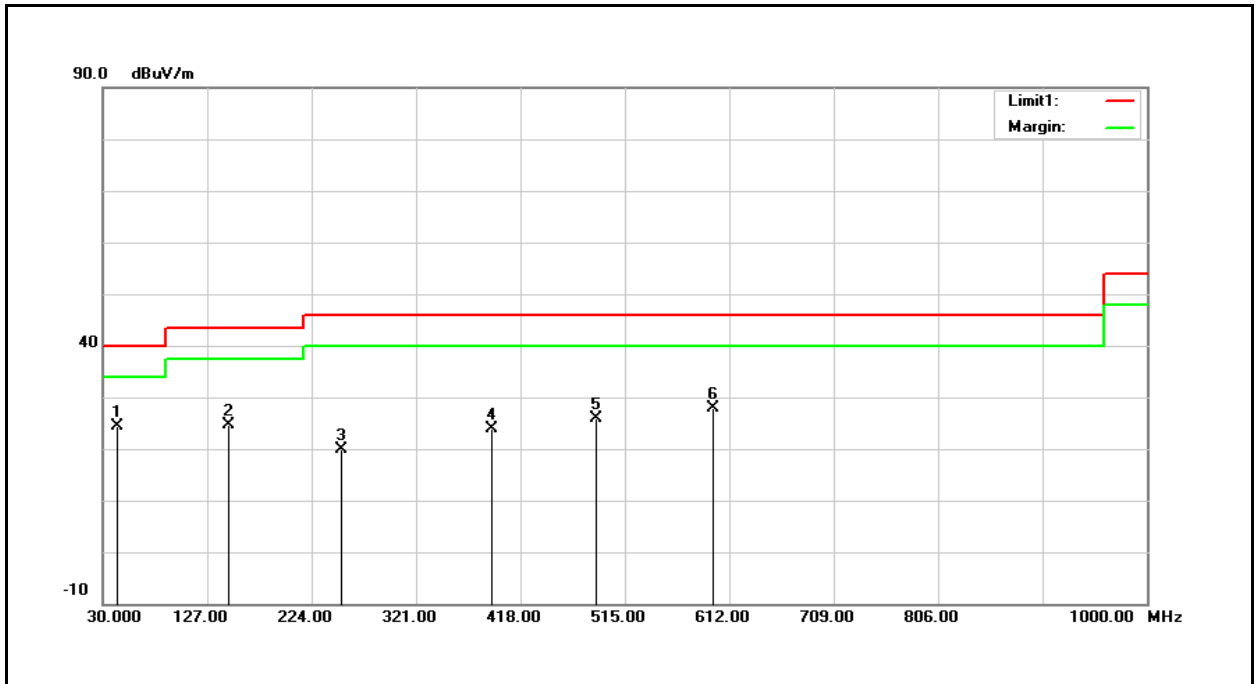

No.	Frequency (MHz)	Reading (dBuV)	Correct Factor (dB/m)	Result (dBuV/m)	Limit (dBuV/m)	Margin (dB)	Remark
1*	43.5800	31.59	-7.10	24.49	40.00	-15.51	QP
2	147.3700	31.63	-7.10	24.53	43.50	-18.97	QP
3	252.1300	27.24	-7.43	19.81	46.00	-26.19	QP
4	391.8100	27.86	-3.92	23.94	46.00	-22.06	QP
5	487.8400	27.86	-2.00	25.86	46.00	-20.14	QP
6	596.4800	27.38	0.55	27.93	46.00	-18.07	QP

Standard:	FCC Part 15.231	Test Distance:	3 m
Test item:	Radiated Emission		
Mode:	Transmit Mode		
Ant.Polar.:	Vertical		

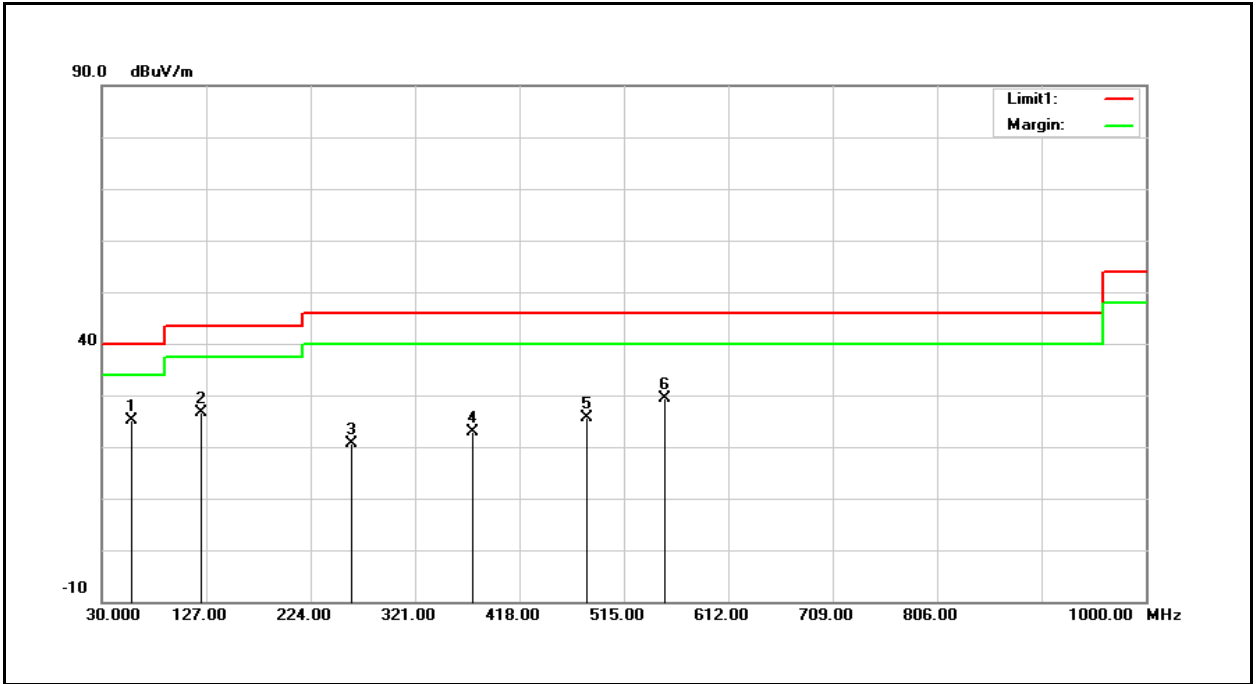

No.	Frequency (MHz)	Reading (dBuV)	Correct Factor (dB/m)	Result (dBuV/m)	Limit (dBuV/m)	Margin (dB)	Remark
1*	58.1300	32.95	-7.86	25.09	40.00	-14.91	QP
2	122.1500	36.17	-9.53	26.64	43.50	-16.86	QP
3	261.8300	27.83	-7.21	20.62	46.00	-25.38	QP
4	374.3500	27.37	-4.38	22.99	46.00	-23.01	QP
5	480.0800	27.81	-2.11	25.70	46.00	-20.30	QP
6	552.8300	30.00	-0.69	29.31	46.00	-16.69	QP

Harmonic

Above 1 GHz

Standard:	FCC Part 15.231	Test Distance:	3 m
Test item:	Harmonic		
Mode:	RFID		
Ant.Polar.:	Horizontal		

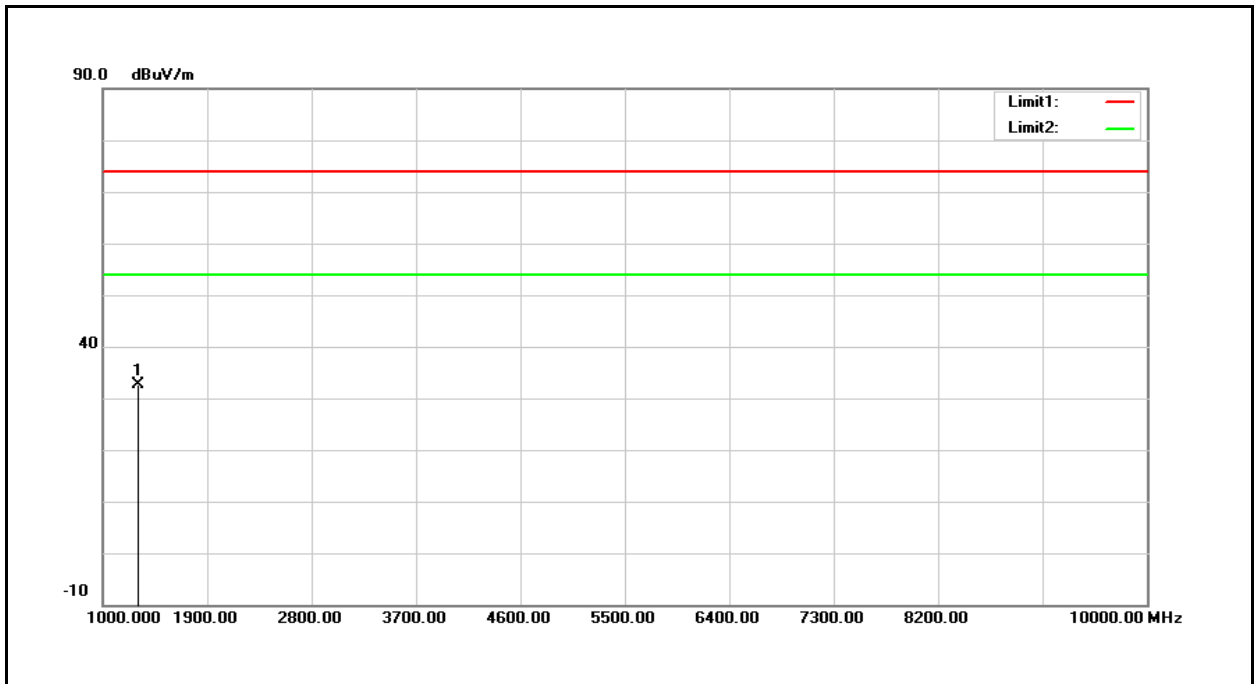

No.	Frequency (MHz)	Reading (dBuV)	Correct Factor (dB/m)	Result (dBuV/m)	Limit (dBuV/m)	Margin (dB)	Remark
1*	1301.730	42.15	-9.50	32.65	74.00	-41.35	peak

Standard:	FCC Part 15.231	Test Distance:	3 m
Test item:	Harmonic		
Mode:	RFID		
Ant.Polar.:	Vertical		

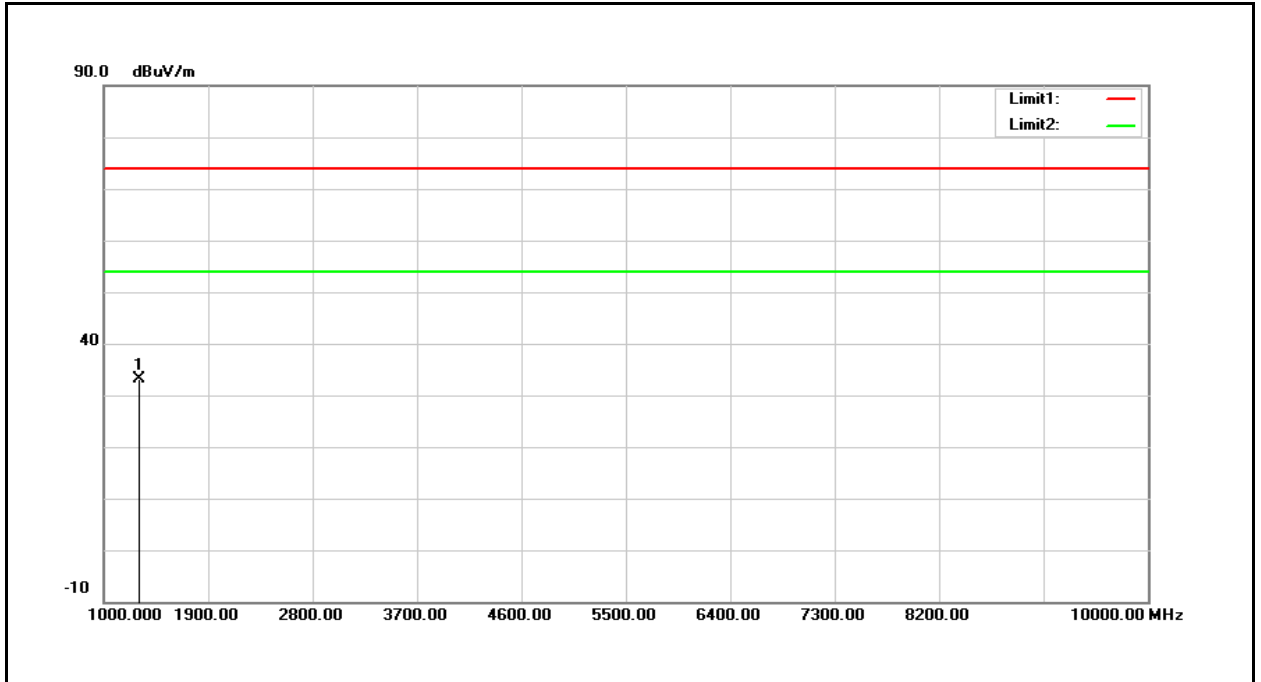

No.	Frequency (MHz)	Reading (dBuV)	Correct Factor (dB/m)	Result (dBuV/m)	Limit (dBuV/m)	Margin (dB)	Remark
1*	1301.730	42.62	-9.50	33.12	74.00	-40.88	peak

Standard:	FCC Part 15.231	Test Distance:	3 m
Test item:	Harmonic		
Mode:	Simultaneous Transmitting		
	BLE + LTE + RFID		
Ant.Polar.:	Horizontal		

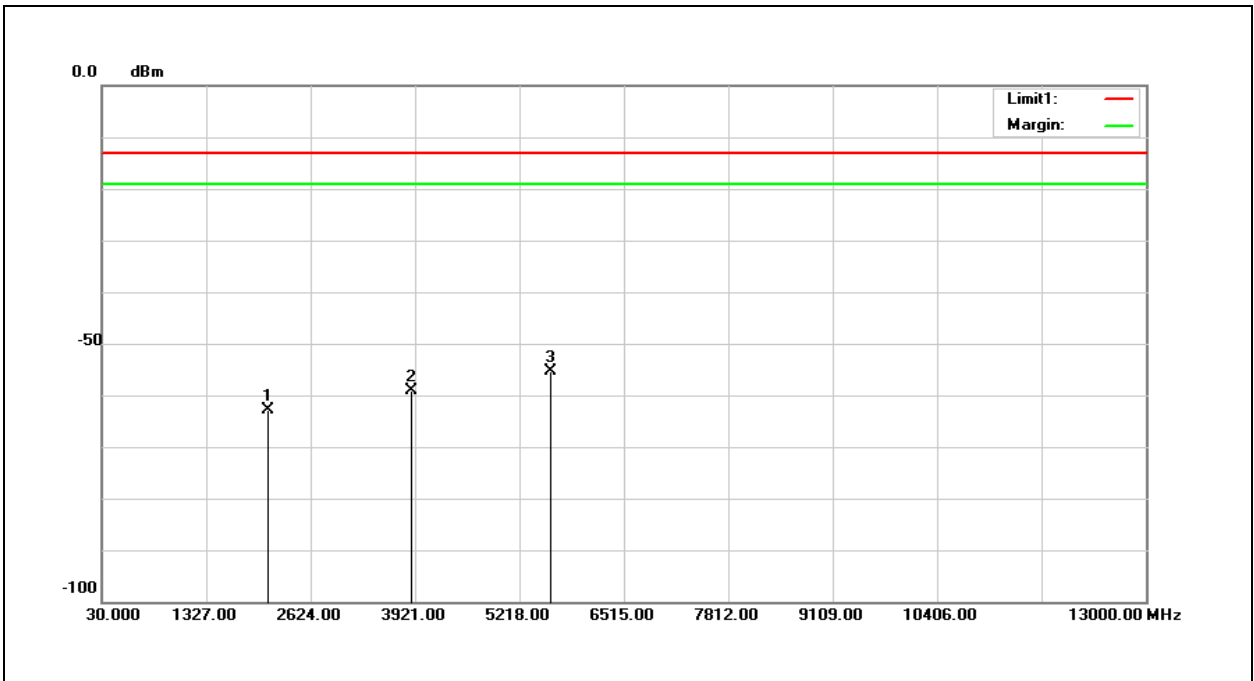

No.	Frequency (MHz)	Reading (dBuV)	Correct Factor (dB/m)	Result (dBuV/m)	Limit (dBuV/m)	Margin (dB)	Remark
1	2092.000	-66.63	3.72	-62.91	-13.00	-49.91	peak
2	3868.000	-68.46	9.26	-59.20	-13.00	-46.20	peak
3*	5596.000	-69.38	14.12	-55.26	-13.00	-42.26	peak

Standard:	FCC Part 15.231	Test Distance:	3 m
Test item:	Harmonic		
Mode:	Simultaneous Transmitting		
	BLE + LTE + RFID		
Ant.Polar.:	Vertical		

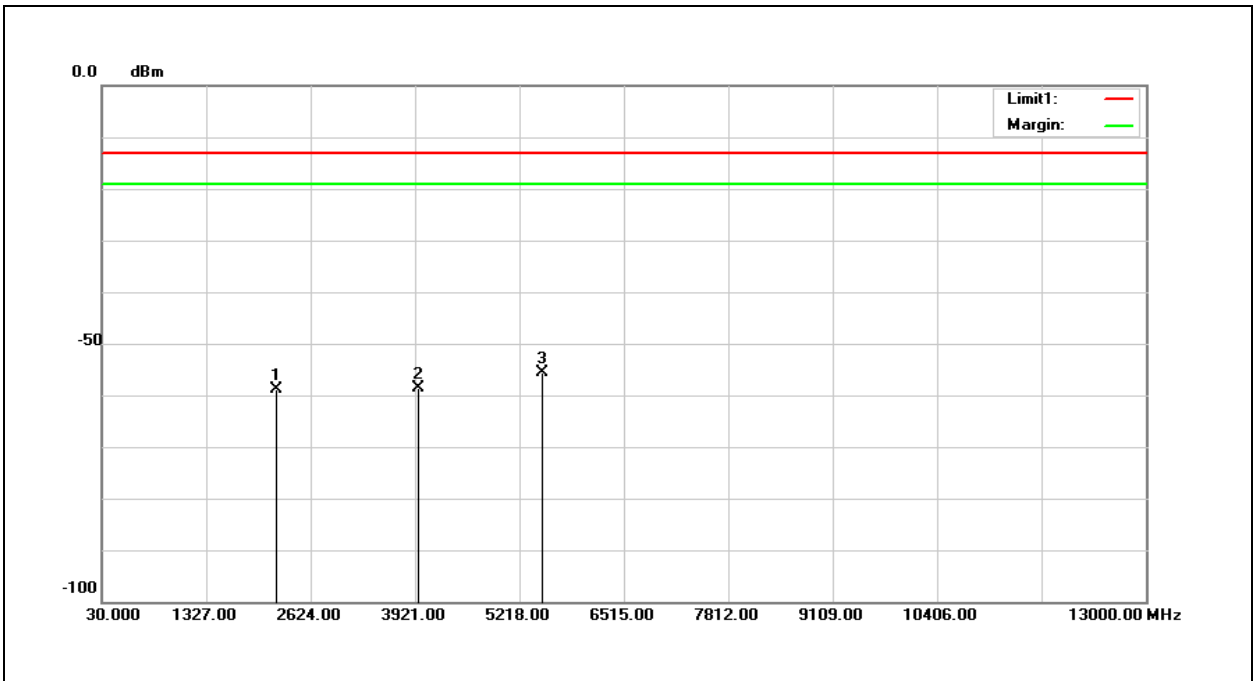

No.	Frequency (MHz)	Reading (dBuV)	Correct Factor (dB/m)	Result (dBuV/m)	Limit (dBuV/m)	Margin (dB)	Remark
1	2188.000	-63.06	4.14	-58.92	-13.00	-45.92	peak
2	3952.000	-68.24	9.55	-58.69	-13.00	-45.69	peak
3*	5500.000	-69.55	13.83	-55.72	-13.00	-42.72	peak

Band Edge

Standard:	FCC Part 15.231	Test Distance:	3 m
Test item:	Band edge		
Mode:	RFID		
Ant.Polar.:	Horizontal		

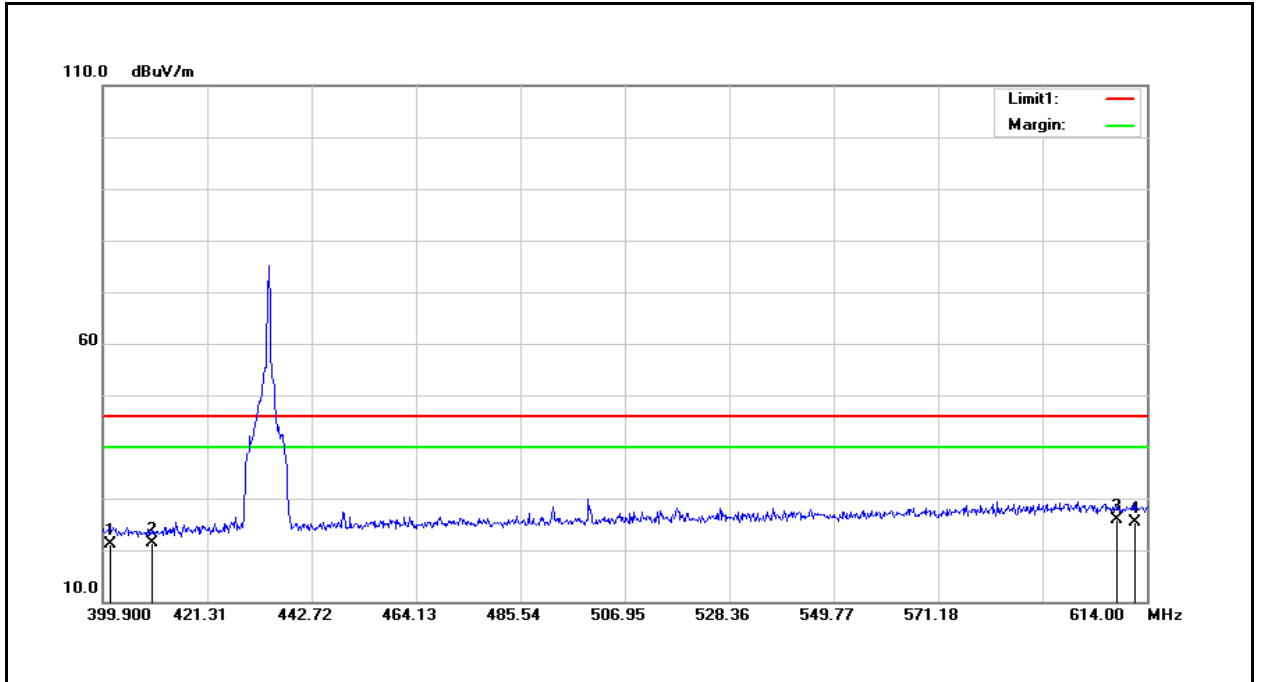

No.	Frequency (MHz)	Reading (dBuV)	Correct Factor (dB/m)	Result (dBuV/m)	Limit (dBuV/m)	Margin (dB)	Remark
1	401.3987	24.86	-3.69	21.17	46.00	-24.83	QP
2	410.0000	24.84	-3.48	21.36	46.00	-24.64	QP
3*	608.0000	25.13	0.69	25.82	46.00	-20.18	QP
4	611.6450	24.58	0.71	25.29	46.00	-20.71	QP

Standard:	FCC Part 15.231	Test Distance:	3 m
Test item:	Band edge		
Mode:	RFID		
Ant.Polar.:	Vertical		

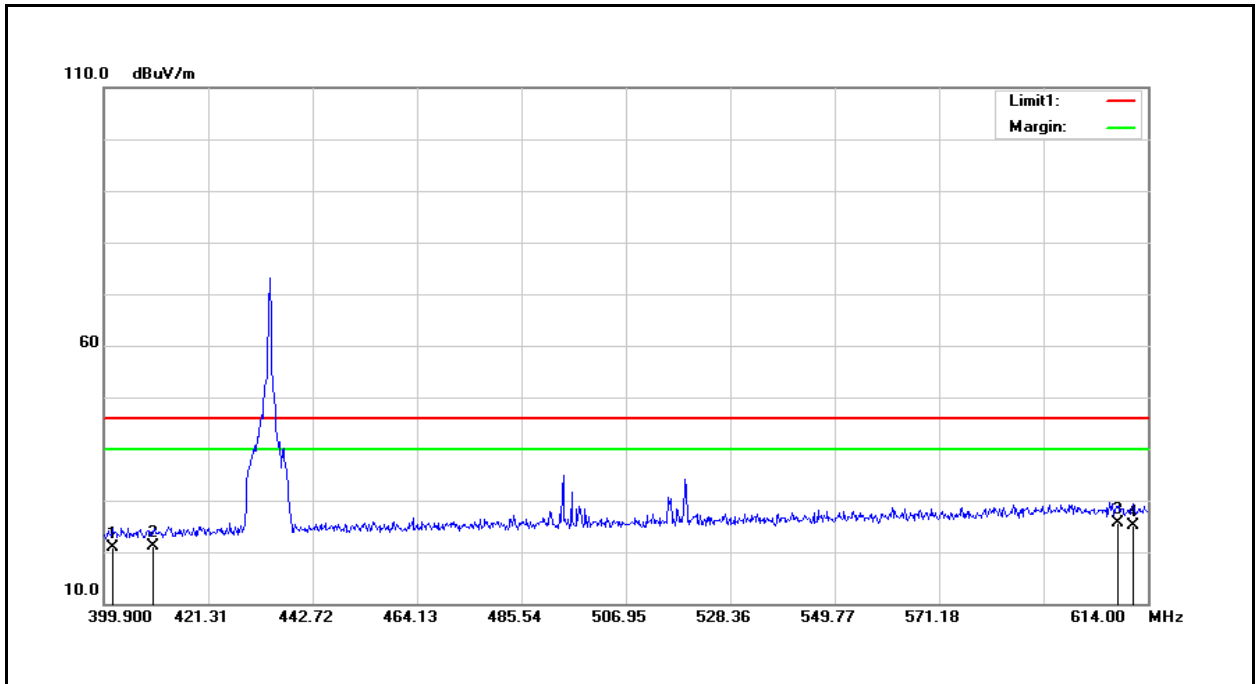

No.	Frequency (MHz)	Reading (dBuV)	Correct Factor (dB/m)	Result (dBuV/m)	Limit (dBuV/m)	Margin (dB)	Remark
1	401.8270	24.61	-3.68	20.93	46.00	-25.07	QP
2	410.0000	24.62	-3.48	21.14	46.00	-24.86	QP
3*	608.0000	24.82	0.69	25.51	46.00	-20.49	QP
4	611.0026	24.39	0.70	25.09	46.00	-20.91	QP

- Note: 1. $\text{Result (dBuV/m)} = \text{Correction factor (dB/m)} + \text{Reading (dBuV)}$.
2. $\text{Correction factor (dB/m)} = \text{Antenna Factor (dB/m)} + \text{Cable loss (dB)} - \text{Pre-Amplifier gain (dB)}$.
3. When peak results are less than average limit, so not need to evaluate the average.

---END---