

# A Test Lab Techno Corp.

No. 140-1, Changan Street, Bade District, Taoyuan City 33465, Taiwan (R.O.C.)

Tel : 886-3-271-0188 / Fax : 886-3-271-0190



## SAR EVALUATION REPORT

Applicant	: MobileHelp, LLC
Product Type	: LTE Module
Trade Name	: Quectel
Model Number	: SC20-A
Received Date	: Apr. 09, 2019
Test Period	: May 07 ~ May 09, 2019
Issue Date	: Jun. 26, 2019
Test Environment	: Ambient Temperature : $22 \pm 2^{\circ} \text{C}$ Relative Humidity : 40 - 70 %
Standard	: ANSI/IEEE C95.1-1992 / IEEE Std. 1528-2013 47 CFR Part §2.1093 KDB 865664 D01 v01r04 / KDB 865664 D02 v01r02 KDB 447498 D01 v06 / KDB 941225 D01 v03r01 KDB 941225 D05 v02r05 / KDB 616217 D04 v01r01 KDB 248227 D01 v02r02
Test Firm MRA designation number	: TW0010



1. A Test Lab Techno Corp. tested the above equipment in accordance with the requirements set forth in the above standards. All indications of Pass/Fail in this report are opinions expressed by A Test Lab Techno Corp. based on interpretations and/or observations of test results. The test results show that the equipment tested is capable of demonstrating compliance with the requirements as documented in this report.
2. This report shall not be reproduced except in full, without the written approval of A Test Lab Techno Corp. This document may be altered or revised by A Test Lab Techno Corp. personnel only, and shall be noted in the revision section of the document. The client should not use it to claim product endorsement by TAF, or any government agencies. The test results in the report only apply to the tested sample.

Approved By : Edison Hu  
(Edison Hu)

Tested By : Kris Pan  
(Kris Pan)



## Revision History

Rev.	Issue Date	Revisions	Revised By
00	Jun. 14, 2019	Initial Issue	Shelly Chen
01	Jun. 26, 2019	Page 50 Revised Standalone SAR Test Exclusion Calculation. Page 52 Revised Tune-up Power.	Shelly Chen



# Contents

1. Summary of Maximum Reported SAR Value.....	4
2. Description of Equipment under Test (EUT) .....	5
3. Introduction.....	7
3.1 SAR Definition .....	7
4. SAR Measurement Setup .....	8
4.1 DASY E-Field Probe System.....	9
4.1.1 E-Field Probe Specification .....	9
4.2 Data Acquisition Electronic (DAE) System.....	10
4.3 Robot.....	10
4.4 Measurement Server.....	10
4.5 Device Holder.....	11
4.6 Oval Flat Phantom - ELI 4.0.....	11
5. Tissue Simulating Liquids.....	12
5.1 The composition of the tissue simulating liquid.....	13
5.2 Liquid Parameters .....	14
5.3 Liquid Depth .....	15
6. SAR Testing with RF Transmitters .....	16
6.1 SAR Testing with WCDMA Transmitters .....	16
6.2 SAR Testing with HSDPA Transmitters .....	16
6.3 SAR Testing with LTE-FDD Transmitters .....	18
6.4 SAR Testing with LTE-TDD Transmitters .....	19
6.5 LTE Frequency range and channel bandwidth.....	20
6.5.1 Maximum power reduction (MPR).....	22
6.6 Power reduction .....	22
6.7 SAR Testing with 802.11 Transmitters.....	23
6.8 Conducted Power.....	24
6.9 Antenna location.....	49
6.10 Standalone SAR Test Exclusion Calculation .....	50
6.11 Simultaneous Transmitting Evaluate.....	52
6.11.1 Sum of 1-g SAR of all simultaneously transmitting .....	53
6.11.2 SAR to peak location separation ratio (SPLSR).....	55
6.12 SAR test reduction according to KDB .....	55
7. System Verification and Validation.....	56
7.1 Symmetric Dipoles for System Verification .....	56
7.2 Verification Summary .....	57
8. Test Equipment List.....	58
9. Measurement Uncertainty .....	59
10. Measurement Procedure.....	61
10.1 Spatial Peak SAR Evaluation .....	61
10.2 Area & Zoom Scan Procedures .....	62
10.3 Volume Scan Procedures.....	62
10.4 SAR Averaged Methods.....	62
10.5 Power Drift Monitoring.....	62
11. SAR Test Results Summary.....	63
11.1 Body SAR Measurement.....	64
11.2 SAR Variability Measurement.....	68
11.3 Std. C95.1-1992 RF Exposure Limit.....	69
12. References.....	70
Appendix A - System Performance Check.....	71
Appendix B - SAR Measurement Data.....	79
Appendix C - Calibration.....	90



## 1. Summary of Maximum Reported SAR Value

Equipment Class	Mode	Highest Reported
		Body standalone SAR <sub>1g</sub> (W/kg)
Licensed	WCDMA Band II	0.91
	WCDMA Band V	0.56
	LTE Band 2 (QPSK)	1.06
	LTE Band 4 (QPSK)	0.94
	LTE Band 5 (QPSK)	0.59
	LTE Band 12 (QPSK)	0.54
DTS	WLAN 2.4 GHz	0.14
U-NII	WLAN 5 GHz	0.21
DSS	Bluetooth	0.06
Highest Simultaneous Transmission SAR		Highest Simultaneous Transmission 1 g SAR (W/kg)
At test position side 4		1.31

NOTE: The SAR limit (Head & Body: SAR<sub>1g</sub> 1.6 W/kg) for general population / uncontrolled exposure is specified in FCC 47 CFR part 2 (2.1093) and ANSI/IEEE C95.1-1992.



## 2. Description of Equipment under Test (EUT)

Applicant	MobileHelp, LLC 5050 Conference Way N, Suite 125, Boca Raton, Florida 33431, United States	
Manufacture	Quectel Wireless Solutions Co., Ltd. 7th Floor, Hongye Building, No.1801 Hongmei Road, Xuhui District, Shanghai 200233, China	
Product Type	LTE Module	
Trade Name	Quectel	
Model Number	SC20-A	
IMEI No.	015559000091890	
FCC ID	PXT-201706SC20A	
Class II permissive change	<p>This is to request a Class II permissive change for FCC ID: PXT-201706SC20A, originally granted on 6/13/2019.</p> <p>The major change filed under this application is:</p> <p>Change #1: Host added, MobileHelp, model number: DC-TBS2-01.</p> <p>#2: Disable GSM, WCDMA B4 and LTE bands B7,B13,B25,B26 by firmware.</p> <p>#3: Reduce the Output Power through firmware, and SAR measurement were evaluated.</p> <p>(Only reduce WCDMA band 2/LTE band 2/Wi-Fi 2.4 GHz/Bluetooth output Power, other undescribed parts haven't changes).</p> <p>#4: Addition antennas, the WWAN WCDMA/LTE band 2 antenna gain higher then original grant, WLAN/Bluetooth antenna type different from original grant. The radiated emission has verified and compliance with FCC regulations. Other undescribed parts antenna gain lower then original grant.</p>	
Host Information	Product Type: Tablet Base Station Trade Name: MobileHelp Model Name: DC-TBS2-01	
RF Function	Operate Bands	Operate Frequency (MHz)
	WCDMA(RMC 12.2K) / HSDPA / HSUPA Band II	1852.4 - 1907.6
	WCDMA (RMC 12.2K) / HSDPA / HSUPA Band V	826.4 - 846.6
	LTE Band 2 (BW 1.4, 3, 5, 10, 15, 20 MHz)	1850 - 1910
	LTE Band 4 (BW 1.4, 3, 5, 10, 15, 20 MHz)	1710 - 1755
	LTE Band 5 (BW 1.4, 3, 5, 10 MHz)	824 - 849
	LTE Band 12 (BW 1.4, 3, 5, 10 MHz)	699 - 716
	IEEE 802.11b / 802.11g / 802.11n 2.4 GHz 20 MHz	2412 - 2462
	IEEE 802.11n 2.4 GHz 40 MHz	2422 - 2452
	IEEE 802.11a	5180 - 5825
	IEEE 802.11n 5 GHz 20 MHz	5180 - 5825
	IEEE 802.11n 5 GHz 40 MHz	5190 - 5795
	Bluetooth BR/EDR	2402 - 2480
	Bluetooth LE	2402 - 2480



Antenna Type	SMT PCB Antenna
Battery Option	Standard
	(1) Manufacturer: Fly Power Industries Limited Model: FLP-9373129 Spec: DC 3.7 V / 10000 mAh (2) Manufacturer: Mica Power Co. Ltd Model: MLP9073102 Spec: DC 3.7 V / 10000 mAh
Device Category	Portable Device
Application Type	Certification

Note: The above EUT's information was declared by manufacturer. Please refer to the specifications or user's manual for more detailed description.



### 3. Introduction

The A Test Lab Techno Corp. has performed measurements of the maximum potential exposure to the user of **MobileHelp, LLC Trade Name : Quectel Model(s) : SC20-A**. The test procedures, as described in American National Standards, Institute C95.1-1999 [ 1 ] were employed and they specify the maximum exposure limit of 1.6 mW/g as averaged over any 1 gram of tissue for portable devices being used within 20 cm between user and EUT in the uncontrolled environment. A description of the product and operating configuration, detailed summary of the test results, methodology and procedures used in the equipment used are included within this test report.

#### 3.1 SAR Definition

Specific Absorption Rate (SAR) is defined as the time derivative (rate) of the incremental energy (dw) absorbed by (dissipated in) an incremental mass (dm) contained in a volume element (dv) of a given density ( $\rho$ ). The equation description is as below :

$$\text{SAR} = \frac{d}{dt} \left( \frac{dw}{dm} \right) = \frac{d}{dt} \left( \frac{dw}{\rho dv} \right)$$

SAR is expressed in units of Watts per kilogram (W/kg)

SAR measurement can be related to the electrical field in the tissue by

$$\text{SAR} = \frac{\sigma |E|^2}{\rho}$$

Where :

$\sigma$  = conductivity of the tissue (S/m)

$\rho$  = mass density of the tissue (kg/m<sup>3</sup>)

$E$  = RMS electric field strength (V/m)

## 4. SAR Measurement Setup

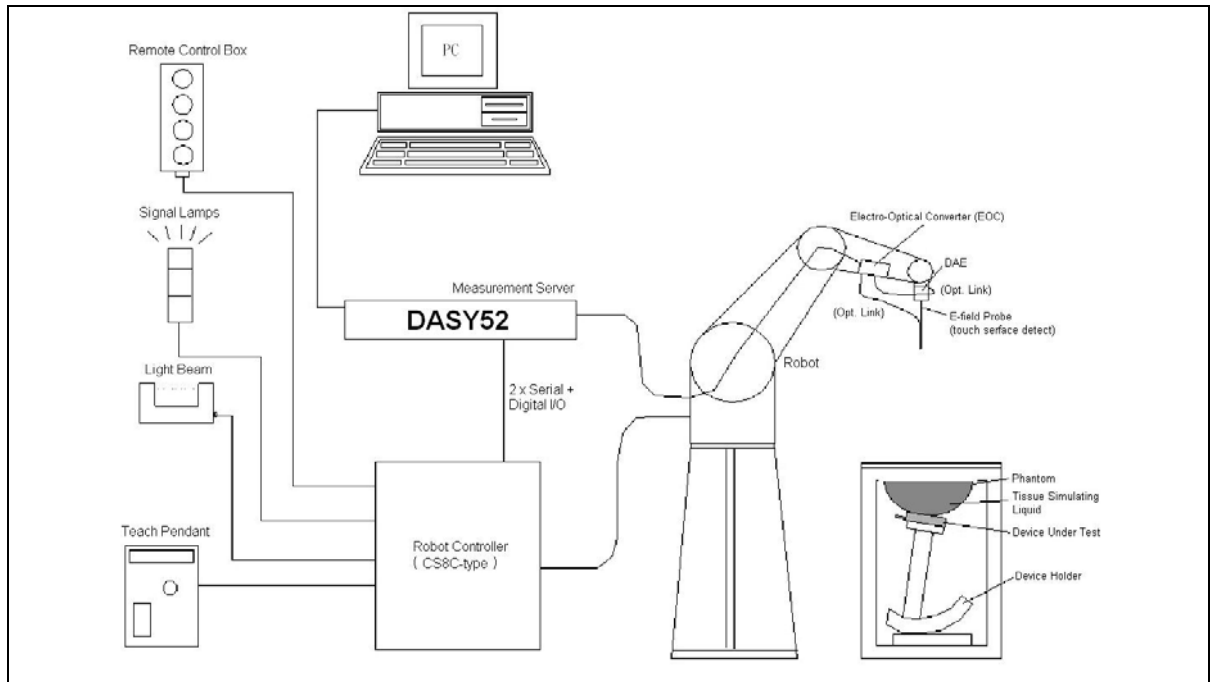

The DASY52 system for performing compliance tests consists of the following items:

1. A standard high precision 6-axis robot (Stäubli TX family) with controller, teach pendant and software. An arm extension for accommodating the data acquisition electronics (DAE).
2. A dosimetric probe, i.e., an isotropic E-field probe optimized and calibrated for usage in tissue simulating liquid. The probe is equipped with an optical surface detector system.
3. A data acquisition electronics (DAE) which performs the signal amplification, signal multiplexing, AD-conversion, offset measurements, mechanical surface detection, collision detection, etc. The unit is battery powered with standard or rechargeable batteries. The signal is optically transmitted to the EOC.
4. The function of the measurement server is to perform the time critical tasks such as signal filtering, control of the robot operation and fast movement interrupts.
5. A probe alignment unit which improves the (absolute) accuracy of the probe positioning.
6. A computer operating Windows 2000 or Windows XP.
7. DASY52 software.
8. Remote controls with teach pendant and additional circuitry for robot safety such as warning lamps, etc.
9. The SAM twin phantom enabling testing left-hand and right-hand usage.
10. The device holder for handheld mobile phones.
11. Tissue simulating liquid mixed according to the given recipes.
12. Validation dipole kits allowing validating the proper functioning of the system.



## 4.1 DASY E-Field Probe System

The SAR measurements were conducted with the dosimetric probe (manufactured by SPEAG), designed in the classical triangular configuration [ 3 ] and optimized for dosimetric evaluation. The probe is constructed using the thick film technique; with printed resistive lines on ceramic substrates. The probe is equipped with an optical multi-fiber line ending at the front of the probe tip. It is connected to the EOC box on the robot arm and provides an automatic detection of the phantom surface. Half of the fibers are connected to a pulsed infrared transmitter, the other half to a synchronized receiver. As the probe approaches the surface, the reflection from the surface produces a coupling from the transmitting to the receiving fibers. This reflection increases first during the approach, reaches maximum and then decreases. If the probe is flatly touching the surface, the coupling is zero. The distance of the coupling maximum to the surface is independent of the surface reflectivity and largely independent of the surface to probe angle. The DASY software reads the reflection during a software approach and looks for the maximum using a 2nd order fitting. The approach is stopped when reaching the maximum.

### 4.1.1 E-Field Probe Specification

Construction	Symmetrical design with triangular core Built-in shielding against static charges PEEK enclosure material (resistant to organic solvents, e.g., DGBE)
Calibration	ISO/IEC 17025 calibration service available
Frequency	10 MHz to > 6 GHz Linearity: $\pm 0.2$ dB (30 MHz to 6 GHz)
Directivity	$\pm 0.3$ dB in brain tissue (rotation around probe axis) $\pm 0.5$ dB in brain tissue (rotation normal probe axis)
Dimensions	Overall length: 337 mm (Tip: 20 mm) Tip diameter: 2.5 mm (Body: 12 mm) Typical distance from probe tip to dipole centers: 1 mm

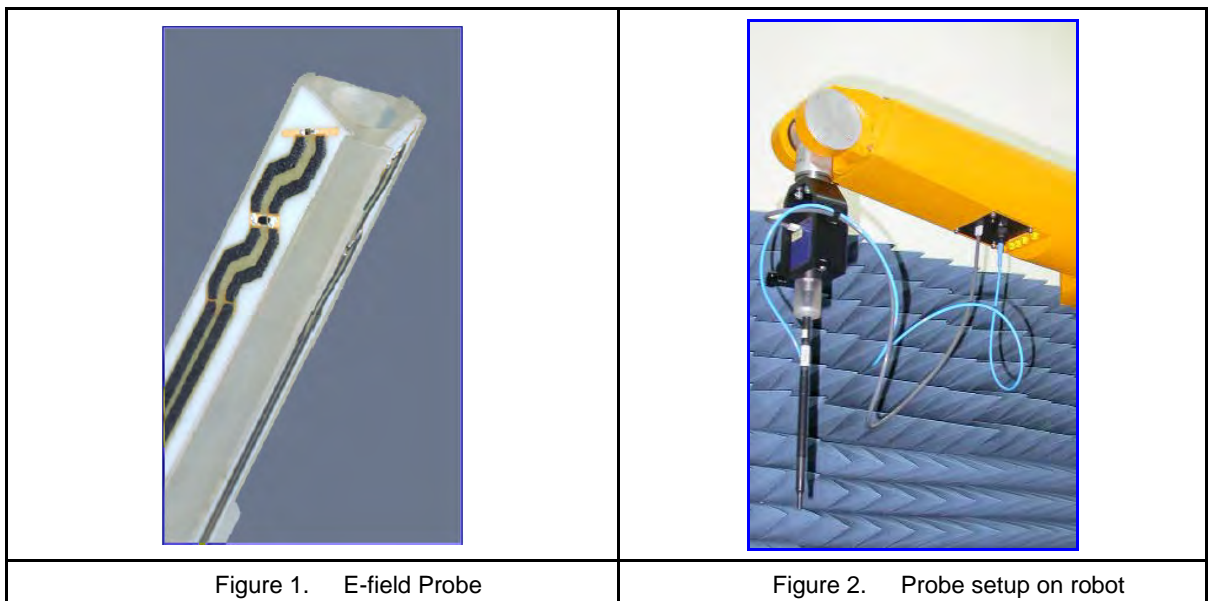



## 4.2 Data Acquisition Electronic (DAE) System

Model : DAE3, DAE4  
Construction : Signal amplifier, multiplexer, A/D converter and control logic. Serial optical link for communication with DASY4/5 embedded system (fully remote controlled). Two step probe touch detector for mechanical surface detection and emergency robot stop.  
Measurement Range : -100 to +300 mV (16 bit resolution and two range settings: 4 mV, 400 mV)  
Input Offset Voltage : < 5  $\mu$ V (with auto zero)  
Input Bias Current : < 50 fA  
Dimensions : 60 x 60 x 68 mm

## 4.3 Robot

Positioner : Stäubli Unimation Corp. Robot Model: TX90XL  
Repeatability :  $\pm 0.02$  mm  
No. of Axis : 6

## 4.4 Measurement Server

Processor : PC/104 with a 400MHz intel ULV Celeron  
I/O-board : Link to DAE4 (or DAE3)  
16-bit A/D converter for surface detection system  
Digital I/O interface  
Serial link to robot  
Direct emergency stop output for robot

## 4.5 Device Holder

The DASY device holder is constructed of low-loss POM material having the following dielectric parameters: relative permittivity  $\epsilon=3$  and loss tangent  $\delta=0.02$ . The amount of dielectric material has been reduced in the closest vicinity of the device, since measurements have suggested that the influence of the clamp on the test results could thus be lowered.

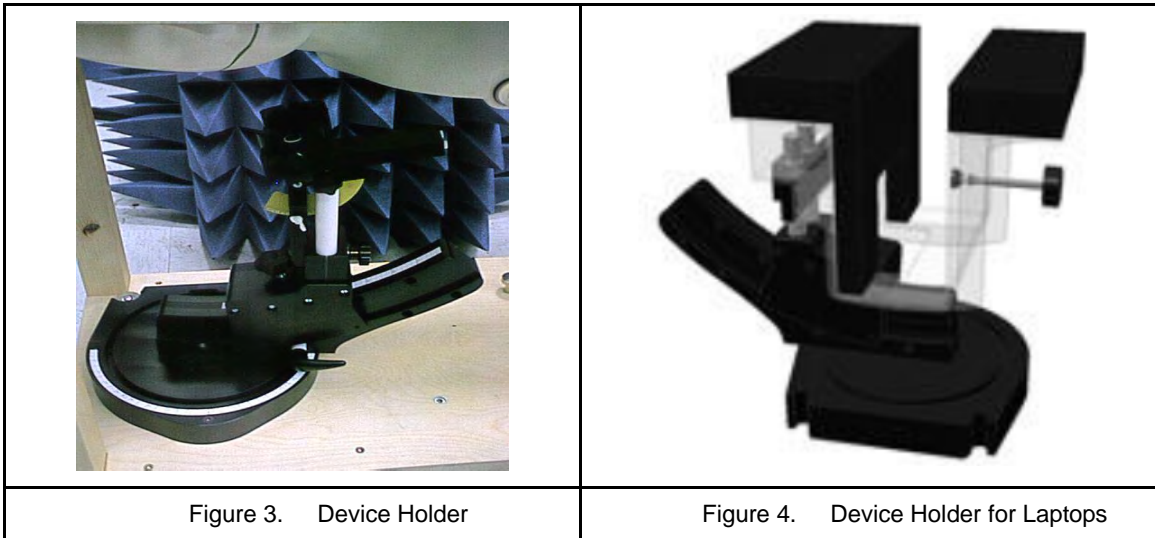

## 4.6 Oval Flat Phantom - ELI 4.0

The shell corresponds to the specifications of the Specific Anthropomorphic Mannequin (Oval Flat) phantom defined in IEEE 1528-2013, CENELEC 50361 and IEC 62209. It enables the dosimetric evaluation of wireless portable device usage as well as body mounted usage at the flat phantom region. A cover prevents evaporation of the liquid. Reference markings on the phantom allow the complete setup of all predefined phantom positions and measurement grids by manually teaching three points with the robot.

Shell Thickness	2 ±0.2 mm
Filling Volume	Approx. 30 liters
Dimensions	190x600x400 mm (HxLxW)
Table 1. Specification of ELI 4.0	

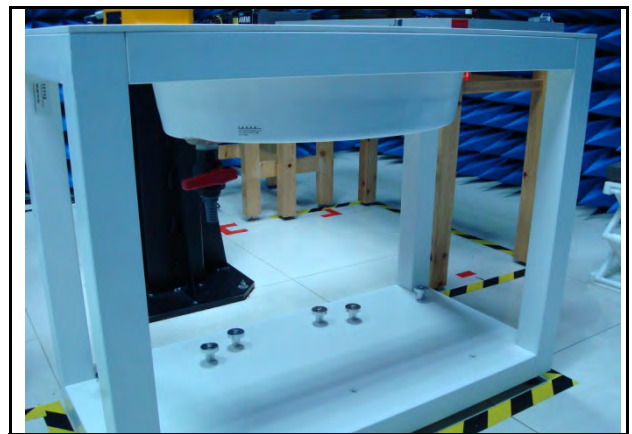

Figure 5. Oval Flat Phantom



## 5. Tissue Simulating Liquids

### IEEE SCC-34/SC-2 in 1528 recommended Tissue Dielectric Parameters

The head tissue dielectric parameters recommended by the IEEE SCC-34/SC-2 in 1528 have been incorporated in the following table. These head parameters are derived from planar layer models simulating the highest expected SAR for the dielectric properties and tissue thickness variations in human head. Other head and body tissue parameters that have not been specified in 1528 are derived from the tissue dielectric parameters computed from the 4-Cole-Cole equation and extrapolated according to the head parameter specified in 1528.

Target Frequency (MHz)	Head		Body	
	$\epsilon_r$	$\sigma$ (S/m)	$\epsilon_r$	$\sigma$ (S/m)
150	52.3	0.76	61.9	0.80
300	45.3	0.87	58.2	0.92
450	43.5	0.87	56.7	0.94
835	41.5	0.90	55.2	0.97
900	41.5	0.97	55.0	1.05
915	41.5	0.98	55.0	1.06
1450	40.5	1.20	54.0	1.30
1610	40.3	1.29	53.8	1.40
1800 - 2000	40.0	1.40	53.3	1.52
2450	39.2	1.80	52.7	1.95
3000	38.5	2.40	52.0	2.73
5800	35.3	5.27	48.2	6.00

(  $\epsilon_r$  = relative permittivity,  $\sigma$  = conductivity and  $\rho = 1000$  kg/m<sup>3</sup> )

Table 2. Tissue dielectric parameters for head and body phantoms



## 5.1 The composition of the tissue simulating liquid

Ingredients (% by weight)	Frequency (MHz)												Frequency (GHz)	
	750		835		1750		1900		2450		2600		5 GHz	
Tissue Type	Head	Body	Head	Body	Head	Body	Head	Body	Head	Body	Head	Body	Head	Body
Water	39.28	51.30	41.45	52.40	54.50	40.20	54.90	40.40	62.70	73.20	60.30	71.40	65.5	78.6
Salt (NaCl)	1.47	1.42	1.45	1.50	0.17	0.49	0.18	0.50	0.50	0.10	0.60	0.20	0.00	0.00
Sugar	58.15	46.18	56.00	45.00	0.00	0.00	0.00	0.00	0.00	0.00	0.00	0.00	0.00	0.00
HEC	1.00	1.00	1.00	1.00	0.00	0.00	0.00	0.00	0.00	0.00	0.00	0.00	0.00	0.00
Bactericide	0.10	0.10	0.10	0.10	0.00	0.00	0.00	0.00	0.00	0.00	0.00	0.00	0.00	0.00
Triton X-100	0.00	0.00	0.00	0.00	0.00	0.00	0.00	0.00	0.00	0.00	0.00	0.00	17.2	10.7
DGBE	0.00	0.00	0.00	0.00	45.33	59.31	44.92	59.10	36.80	26.70	39.10	28.40	0.00	0.00
Dielectric Constant	41.88	54.60	42.54	56.10	40.10	53.60	39.90	54.00	39.80	52.50	39.80	52.50	35.1~ 36.2	47.9~ 49.3
Conductivity (S/m)	0.90	0.97	0.91	0.95	1.39	1.49	1.42	1.45	1.88	1.78	1.88	1.78	4.45~ 5.48	5.07~ 6.23
Diethylene Glycol Mono-hexlether	0.00	0.00	0.00	0.00	0.00	0.00	0.00	0.00	0.00	0.00	0.00	0.00	17.3	10.7



## 5.2 Liquid Parameters

The dielectric parameters of the liquids were verified prior to the SAR evaluation using an 85070C Dielectric Probe Kit and an E5071B Network Analyzer.

Tissue Temp (°C)	Head / Body	Frequency (MHz)	Cond.	Perm.	target Cond.	target Perm.	$\sigma$ (Delta) (%)	$\epsilon_r$ (Delta) (%)	Limit (%)	Date
			$\sigma$	$\epsilon_r$	$\sigma$	$\epsilon_r$				
22.3	Body	1852.4	1.53	52.759	1.52	53.30	0.45	-1.02	±5	May. 07, 2019
22.3	Body	1880.0	1.56	52.727	1.52	53.30	2.62	-1.08	±5	May. 07, 2019
22.3	Body	1907.6	1.59	52.661	1.52	53.30	4.34	-1.20	±5	May. 07, 2019
22.3	Body	1860.0	1.54	52.746	1.52	53.30	1.16	-1.04	±5	May. 07, 2019
22.3	Body	1880.0	1.56	52.727	1.52	53.30	2.62	-1.08	±5	May. 07, 2019
22.3	Body	1900.0	1.58	52.694	1.52	53.30	3.89	-1.14	±5	May. 07, 2019
22.4	Body	826.4	0.99	56.991	0.97	55.23	2.23	3.19	±5	May. 08, 2019
22.4	Body	846.6	1.01	56.810	0.98	55.16	2.64	2.99	±5	May. 08, 2019
22.4	Body	836.6	1.00	56.894	0.97	55.200	2.98	3.07	±5	May. 08, 2019
22.4	Body	836.5	1.00	56.899	0.97	55.20	2.91	3.08	±5	May. 08, 2019
22.4	Body	1732.5	1.44	53.232	1.48	53.48	-2.51	-0.46	±5	May. 08, 2019
22.1	Body	707.5	0.93	57.160	0.96	55.67	-2.90	2.68	±5	May. 08, 2019
22.2	Body	2412.0	1.93	52.035	1.91	52.75	0.71	-1.35	±5	May. 09, 2019
22.2	Body	2437.0	1.96	51.979	1.94	52.72	0.91	-1.41	±5	May. 09, 2019
22.2	Body	2462.0	1.99	51.924	1.97	52.68	0.92	-1.44	±5	May. 09, 2019
22.2	Body	2402.0	1.92	52.058	1.90	52.76	0.65	-1.33	±5	May. 09, 2019
22.2	Body	2441.0	1.96	51.971	1.94	52.71	0.99	-1.40	±5	May. 09, 2019
22.2	Body	2480.0	2.01	51.877	1.99	52.66	0.69	-1.49	±5	May. 09, 2019
22.4	Body	5260.0	5.21	48.710	5.37	48.93	-2.96	-0.45	±5	May. 09, 2019
22.4	Body	5280.0	5.24	48.670	5.39	48.91	-2.84	-0.49	±5	May. 09, 2019
22.4	Body	5320.0	5.28	48.590	5.44	48.85	-2.87	-0.53	±5	May. 09, 2019
22.4	Body	5500.0	5.53	48.220	5.65	48.61	-2.09	-0.80	±5	May. 09, 2019
22.4	Body	5580.0	5.64	48.020	5.74	48.50	-1.83	-0.99	±5	May. 09, 2019
22.4	Body	5660.0	5.73	47.870	5.84	48.39	-1.78	-1.07	±5	May. 09, 2019
22.4	Body	5700.0	5.80	47.780	5.88	48.34	-1.38	-1.16	±5	May. 09, 2019
22.4	Body	5745.0	5.85	47.760	5.94	48.27	-1.47	-1.06	±5	May. 09, 2019
22.4	Body	5785.0	5.90	47.590	5.98	48.22	-1.30	-1.31	±5	May. 09, 2019
22.4	Body	5825.0	5.96	47.560	6.00	48.20	-0.65	-1.33	±5	May. 09, 2019

### 5.3 Liquid Depth

According to KDB865664 ,the depth of tissue-equivalent liquid in a phantom must be  $\geq 15.0$  cm with  $\leq \pm 0.5$  cm variation for SAR measurements  $\leq 3$  GHz and  $\geq 10.0$  cm with  $\leq \pm 0.5$  cm variation for measurements  $> 3$  GHz.



Figure 6. Liquid Height for Body SAR



## 6. SAR Testing with RF Transmitters

### 6.1 SAR Testing with WCDMA Transmitters

The following tests were completed according to the test requirements outlined in section 5.2 of the 3GPP TS34.121-1 specification. The DUT supports power Class 3, which has a nominal maximum output power of 24 dBm (+1.7/-3.7).

- Step 1: set a Test Mode 1 loop back with a 12.2 kbps Reference Measurement Channel (RMC).
- Step 2: set and send continuously up power control commands to the device.
- Step 3: measure the power at the device antenna connector using the power meter with average detector and test SAR

### 6.2 SAR Testing with HSDPA Transmitters

#### HSDPA Date Devices setup for SAR Measurement

HSDPA should be configured according to the UE category of a test device. The number of HS-DSCH/HS-PDSCHs, HARQ processes, minimum inter-TTI interval, transport block sizes and RV coding sequence are defined by the H-set. To maintain a consistent test configuration and stable transmission conditions, QPSK is used in the H-set for SAR testing. HS-DPCCH should be configured with a CQI feedback cycle of 4 ms with a CQI repetition factor of 2 to maintain a constant rate of active CQI slots. DPCCH and DPDCH gain factors( $\beta_c$ ,  $\beta_d$ ), and HS-DPCCH power offset parameters ( $\Delta_{ACK}$ ,  $\Delta_{NACK}$ ,  $\Delta_{CQI}$ ) should be set according to values indicated in the Table below. The CQI value is determined by the UE category, transport block size, number of HS-PDSCHs and modulation used in the H-set.

Setup for Release 5 HSDPA							
Sub-test	$\beta_c$	$\beta_d$	$\beta_d$ (SF)	$\beta_c/\beta_d$	$\beta_{hs}^{(1,2)}$	$CM^{(3)}$ (dB)	$MRP^{(3)}$ (dB)
1	2/15	15/15	64	2/15	4/15	0.0	0.0
2	12/15(4)	15/15(4)	64	12/15(4)	24/15	1.0	0.0
3	15/15	8/15	64	15/8	30/15	1.5	0.5
4	15/15	4/15	64	15/4	30/15	1.5	0.5

Note

1.  $\Delta_{ACK}$ ,  $\Delta_{NACK}$  and  $\Delta_{CQI} = 8 \Leftrightarrow A_{hs} = \beta_{hs}/\beta_c = 30/15 \Leftrightarrow \beta_{hs} = 30/15 * \beta_c$
2. For the HS-DPCCH power mask requirement test in clause 5.2C, 5.7A, and the Error Vector Magnitude(EVM) with HS-DPCCH test in clause 5.13.1A and HSDPA EVM with phase discontinuity in clause 5.13.1AA,  $\Delta_{ACK}$  and  $\Delta_{NACK} = 30/15$  with  $\beta_{hs} = 30/15 * \beta_c$  and  $\Delta_{CQI} = 24/15$  with  $\beta_{hs} = 24/15 * \beta_c$
3.  $CM = 1$  for  $\beta_c/\beta_d = 12/15$ ,  $\beta_{hs}/\beta_c = 24/15$ . For all other combinations of DPDCH, DPCCH and HS-DPCCH the MPR is based on the relative CM difference. This is applicable for only UEs that support HSDPA in release 6 and later releases.
4. For subtest 2 the  $\beta_c/\beta_d$  ratio of 12/15 for the TFC during the measurement period (TF1, TF0) is achieved by setting the signaled gain factors for the reference TFC (TF1, TF1) to  $\beta_c = 11/15$  and  $\beta_d = 15/15$ .





### **HSPA Data Devices setup for SAR Measurement.**

The following procedures are applicable to HSPA (HSUPA/HSDPA) data devices operating under 3GPP Release 6. Body exposure conditions generally apply to these devices, including handsets and data modems operating in various electronic devices. HSUPA operates in conjunction with WCDMA and HSDPA. SAR is initially measured in WCDMA test configurations without HSPA. The default test configuration is to establish a radio link between the DUT and a communication test set to configure a 12.2 kbps RMC (reference measurement channel) in Test Loop Mode 1. SAR for HSPA is selectively measured with HS-DPCCH, EDPCCH and E-DPDCH, all enabled, along with a 12.2 kbps RMC using the highest SAR configuration in WCDMA with 12.2 kbps RMC only. An FRC is configured according to HSDPCCH Sub-test 1 using H-set 1 and QPSK. HSPA is configured according to E-DCH Subtest 5 requirements. SAR for other HSPA sub-test configurations is also confirmed selectively according to output power, exposure conditions and E-DCH UE Category. Maximum output power is verified according to procedures in applicable versions of 3GPP TS 34.121 and SAR must be measured according to these maximum output conditions. The UE Categories for HSDPCCH and HSPA should be clearly identified in the SAR report. The following procedures are applicable only if Maximum Power Reduction (MPR) is implemented according to Cubic Metric (CM) requirements.

When voice transmission and head exposure conditions are applicable to a WCDMA/HSPA data device, head exposure is measured according to the 'Head SAR Measurements' procedures in the 'WCDMA Handsets' section of this document. SAR for body exposure configurations are measured according to the 'Body SAR Measurements' procedures in the 'WCDMA Handsets' section of this document. In addition, body SAR is also measured for HSPA when the maximum average output of each RF channel with HSPA active is at least ¼ dB higher than that measured without HSPA using 12.2 kbps RMC or the maximum SAR for 12.2 kbps RMC is above 75% of the SAR limit. Body SAR for HSPA is measured with E-DCH Sub-test 5, using H-Set 1 and QPSK for FRC and a 12.2 kbps RMC configured in Test Loop Mode 1 with power control algorithm 2, according to the highest body SAR configuration in 12.2 kbps RMC without HSPA. When VOIP is applicable for head exposure, SAR is not required when the maximum output of each RF channel with HSPA is less than ¼ dB higher than that measured using 12.2 kbps RMC; otherwise, the same HSPA configuration used for body measurements should be used to test for head exposure.

Due to inner loop power control requirements in HSPA, a commercial communication test set should be used for the output power and SAR tests. The 12.2 kbps RMC, FRC H-set 1 and E-DCH configurations for HSPA should be configured according to the  $\beta$  values indicated below as well as other applicable procedures described in the 'WCDMA Handset' and 'Release 5 HSDPA Data Devices' sections of this document.



The highest body SAR measured in Antenna Extended & Retracted configurations on a channel in 12.2 kbps RMC. The possible channels are the High, Middle & Low channel. Contact the FCC Laboratory for test and approval requirements if the maximum output power measured in E-DCH Sub-test 2 - 4 is higher than Sub-test 5.

Setup for Release 6 HSPA / Release 7 HSPA+													
Sub-test	$\beta_c$	$\beta_d$	$\beta_d$ (SF)	$\beta_c/\beta_d$	$\beta_{hs}^{(1)}$	$\beta_{ec}$	$\beta_{ed}$	Bed (SF)	Bed (codes)	CM <sup>(2)</sup> (dB)	MPR (dB)	AG <sup>(4)</sup> Index	E-TFCI
1	11/15 <sup>(3)</sup>	15/15 <sup>(3)</sup>	64	11/15 <sup>(3)</sup>	22/15	209/225	1039/225	4	1	1.0	0.0	20	75
2	6/15	15/15	64	6/15	12/15	12/15	94/75	4	1	3.0	2.0	12	67
3	15/15	9/15	64	15/9	30/15	30/15	$\beta_{ed1}$ : 47/15 $\beta_{ed2}$ : 47/15	4	2	2.0	1.0	15	92
4	2/15	15/15	64	2/15	4/15	2/15	56/75	4	1	3.0	2.0	17	71
5	15/15 <sup>(4)</sup>	15/15 <sup>(4)</sup>	64	15/15 <sup>(4)</sup>	30/15	24/15	134/15	4	1	1.0	0.0	21	81

Note

- $\Delta_{ACK}$ ,  $\Delta_{NACK}$  and  $\Delta_{CQI} = 8 \Leftrightarrow A_{hs} = \beta_{hs}/\beta_c = 30/15 \Leftrightarrow \beta_{hs} = 30/15 * \beta_c$ .
- CM = 1 for  $\beta_c/\beta_d = 12/15$ ,  $\beta_{hs}/\beta_c = 24/15$ . For all other combinations of DPDCH, DPCCH, HS-DPCCH, E-DPDCH and E-DPCCH the MPR is based on the relative CM difference.
- For subtest 1 the  $\beta_c/\beta_d$  ratio of 11/15 for the TFC during the measurement period (TF1, TF0) is achieved by setting the signaled gain factors for the reference TFC (TF1, TF1) to  $\beta_c = 10/15$  and  $\beta_d = 15/15$ .
- For subtest 5 the  $\beta_c/\beta_d$  ratio of 15/15 for the TFC during the measurement period (TF1, TF0) is achieved by setting the signaled gain factors for the reference TFC (TF1, TF1) to  $\beta_c = 14/15$  and  $\beta_d = 15/15$ .
- Testing UE using E-DPDCH Physical Layer category 1 Sub-test 3 is not required according to TS 25.306 Table 5.1g.
- $\beta_{ed}$  can not be set directly; it is set by Absolute Grant Value.

### 6.3 SAR Testing with LTE-FDD Transmitters

All SAR measurements for LTE were performed using the Anritsu MT8820C. A closed loop power control setting allowed the UE to transmit at the maximum output power during the SAR measurements. Configure the basestation to support LTE tests in respect to the 3GPP 36.521-1, and set ch, RB allocation number, RB allocation offset, and send continuously Up power control commands to the device.

MPR was enabled for this device. A-MPR was disabled for all SAR test measurements.



## 6.4 SAR Testing with LTE-TDD Transmitters

All SAR measurements for LTE were performed using the Anritsu MT8820C. A closed loop power control setting allowed the UE to transmit at the maximum output power during the SAR measurements. Configure the basestation to support LTE tests in respect to the 3GPP 36.521-1, and set ch , TDD mode , RB allocation number ,RB allocation offset , and send continuously Up power control commands to the device.

MPR was enabled for this device. A-MPR was disabled for all SAR test measurements.

For 3GPP table 4.2.1 as below, support configurations and worst-case UpPTS information into the table.

**3GPP Table 4.2-1: Configuration of special subframe (lengths of DwPTS/GP/UpPTS).**

Special subframe configuration	Normal cyclic prefix in downlink			Extended cyclic prefix in downlink			EUT Support Special subframe	Worst case UpPTS	
	DwPTS	UpPTS		DwPTS	UpPTS				
		Normal cyclic prefix in uplink	Extended cyclic prefix in uplink		Normal cyclic prefix in uplink	Extended cyclic prefix in uplink			
0	$6592 \times T_s$	$2192 \times T_s$	$2560 \times T_s$	$7680 \times T_s$	$2192 \times T_s$	$2560 \times T_s$	<input type="checkbox"/>	<input type="checkbox"/>	
1	$19760 \times T_s$			$20480 \times T_s$			<input type="checkbox"/>	<input type="checkbox"/>	
2	$21952 \times T_s$			$23040 \times T_s$			<input type="checkbox"/>	<input type="checkbox"/>	
3	$24144 \times T_s$			$25600 \times T_s$			<input checked="" type="checkbox"/>	<input type="checkbox"/>	
4	$26336 \times T_s$			$7680 \times T_s$			<input checked="" type="checkbox"/>	<input type="checkbox"/>	
5	$6592 \times T_s$	$4384 \times T_s$	$5120 \times T_s$	$20480 \times T_s$	$4384 \times T_s$	$5120 \times T_s$	<input type="checkbox"/>	<input type="checkbox"/>	
6	$19760 \times T_s$			$23040 \times T_s$			<input type="checkbox"/>	<input type="checkbox"/>	
7	$21952 \times T_s$			$12800 \times T_s$			<input checked="" type="checkbox"/>	<input checked="" type="checkbox"/>	
8	$24144 \times T_s$			-			-	<input type="checkbox"/>	<input type="checkbox"/>
9	$13168 \times T_s$			-			-	<input type="checkbox"/>	<input type="checkbox"/>
Duty cycle <sub>(maximum)</sub>								43.33 %	

The EUT only supports the 40 % case, which is Table 4.2.2, configuration #1 below.

Uplink-downlink configuration	Downlink-to-Uplink Switch-point periodicity	Subframe number										Type of EUT
		0	1	2	3	4	5	6	7	8	9	
0	5ms	D	S	U	U	U	D	S	U	U	U	<input type="checkbox"/>
1	5ms	D	S	U	U	D	D	S	U	U	D	<input checked="" type="checkbox"/>
2	5ms	D	S	U	D	D	D	S	U	D	D	<input type="checkbox"/>
3	10ms	D	S	U	U	U	D	D	D	D	D	<input type="checkbox"/>
4	10ms	D	S	U	U	D	D	D	D	D	D	<input type="checkbox"/>
5	10ms	D	S	U	D	D	D	D	D	D	D	<input type="checkbox"/>
6	5ms	D	S	U	U	U	D	S	U	U	D	<input type="checkbox"/>



## 6.5 LTE Frequency range and channel bandwidth

Channel bandwidth support:

Band	BW (MHz)					
	1.4	3	5	10	15	20
LTE Band 2	V	V	V	V	V	V
LTE Band 4	V	V	V	V	V	V
LTE Band 5	V	V	V	V	---	---
LTE Band 12	V	V	V	V	---	---

LTE Band	Bandwidth (MHz)	Test frequency ID	N <sub>UL</sub>	Frequency of Uplink (MHz)
LTE Band 2	1.4	Low Range	18607	1850.7
		Mid Range	18900	1880.0
		High Range	19193	1909.3
	3	Low Range	18615	1851.5
		Mid Range	18900	1880.0
		High Range	19185	1908.5
	5	Low Range	18625	1852.5
		Mid Range	18900	1880.0
		High Range	19175	1907.5
	10	Low Range	18650	1855.0
		Mid Range	18900	1880.0
		High Range	19150	1905.0
	15	Low Range	18675	1857.5
		Mid Range	18900	1880.0
		High Range	19125	1902.5
20	Low Range	18700	1860.0	
	Mid Range	18900	1880.0	
	High Range	19100	1900.0	



LTE Band	Bandwidth (MHz)	Test frequency ID	N <sub>UL</sub>	Frequency of Uplink (MHz)
LTE Band 4	1.4	Low Range	19957	1710.7
		Mid Range	20175	1732.5
		High Range	20393	1754.3
	3	Low Range	19965	1711.5
		Mid Range	20175	1732.5
		High Range	20385	1753.5
	5	Low Range	19975	1712.5
		Mid Range	20175	1732.5
		High Range	20375	1752.5
	10	Low Range	20000	1715.0
		Mid Range	20175	1732.5
		High Range	20350	1750.0
	15	Low Range	20025	1717.5
		Mid Range	20175	1732.5
		High Range	20325	1747.5
20	Low Range	20050	1720.0	
	Mid Range	20175	1732.5	
	High Range	20300	1745.0	
LTE Band 5	1.4	Low Range	20407	824.7
		Mid Range	20525	836.5
		High Range	20643	848.3
	3	Low Range	20415	825.5
		Mid Range	20525	836.5
		High Range	20635	847.5
	5	Low Range	20425	826.5
		Mid Range	20525	836.5
		High Range	20625	846.5
	10	Low Range	20450	829.0
		Mid Range	20525	836.5
		High Range	20600	844.0



LTE Band	Bandwidth (MHz)	Test frequency ID	N <sub>UL</sub>	Frequency of Uplink (MHz)
LTE Band 12	1.4	Low Range	23017	699.7
		Mid Range	23095	707.5
		High Range	23173	715.3
	3	Low Range	23025	700.5
		Mid Range	23095	707.5
		High Range	23165	714.5
	5	Low Range	23035	701.5
		Mid Range	23095	707.5
		High Range	23155	713.5
	10	Low Range	23060	704.0
		Mid Range	23095	707.5
		High Range	23130	711.0

### 6.5.1 Maximum power reduction (MPR)

Identify the LTE voice/data requirements in each operating mode and exposure condition with respect to head and body test configurations, antenna locations, handset flip-cover or slide positions, antenna diversity conditions etc.

The voice and data transmission:

- ◆ Data only device.

Identify if Maximum Power Reduction (MPR) is optional or mandatory, i.e. built-in by design:

- ◆ Maximum Power Reduction (MPR) is mandatory, i.e. built-in by design.
- ◆ A-MPR (additional MPR) must be disabled
- ◆ A-MPR was disabled during testing.

Maximum Power Reduction (MPR) for Power Class 3							
Channel bandwidth / Transmission bandwidth configuration (RB)							
Modulation	1.4 MHz	3 MHz	5 MHz	10 MHz	15 MHz	20MHz	MPR (dB)
QPSK	> 5	> 4	> 8	> 12	> 16	> 18	≤ 1
16 QAM	≤ 5	≤ 4	≤ 8	≤ 12	≤ 16	≤ 18	≤ 1
16 QAM	> 5	> 4	> 8	> 12	> 16	> 18	≤ 2

### 6.6 Power reduction

No power reduction issue.



## 6.7 SAR Testing with 802.11 Transmitters

SAR test reduction for 802.11 Wi-Fi transmission mode configurations are considered separately for DSSS and OFDM. An initial test position is determined to reduce the number of tests required for certain exposure configurations with multiple test positions. An initial test configuration is determined for each frequency band and aggregated band according to maximum output power, channel bandwidth, wireless mode configurations and other operating parameters to streamline the measurement requirements. For 2.4 GHz DSSS, either the initial test position or DSSS procedure is applied to reduce the number of SAR tests; these are mutually exclusive. For OFDM, an initial test position is only applicable to next to the ear, UMPC mini-tablet and hotspot mode configurations, which is tested using the initial test configuration to facilitate test reduction. For other exposure conditions with a fixed test position, SAR test reduction is determined using only the initial test configuration.

The multiple test positions require SAR measurements in head, hotspot mode or UMPC mini-tablet configurations may be reduced according to the highest reported SAR determined using the initial test position(s) by applying the DSSS or OFDM SAR measurement procedures in the required wireless mode test configuration(s). The initial test position(s) is measured using the highest measured maximum output power channel in the required wireless mode test configuration(s). When the reported SAR for the initial test position is:

- $\leq 0.4$  W/kg, further SAR measurement is not required for the other test positions in that exposure configuration and wireless mode combination within the frequency band or aggregated band. DSSS and OFDM configurations are considered separately according to the required SAR procedures.
- $> 0.4$  W/kg, SAR is repeated using the same wireless mode test configuration tested in the initial test position to measure the subsequent next closet/smallest test separation distance and maximum coupling test position, on the highest maximum output power channel, until the reported SAR is  $\leq 0.8$  W/kg or all required test positions are tested.
  - For subsequent test positions with equivalent test separation distance or when exposure is dominated by coupling conditions, the position for maximum coupling condition should be tested.
  - When it is unclear, all equivalent conditions must be tested.
- For all positions/configurations tested using the initial test position and subsequent test positions, when the reported SAR is  $> 0.8$  W/kg, measure the SAR for these positions/configurations on the subsequent next highest measured output power channel(s) until the reported SAR is  $\leq 1.2$  W/kg or all required test channels are considered.
  - The additional power measurements required for this step should be limited to those necessary for identifying subsequent highest output power channels to apply the test reduction.
- When the specified maximum output power is the same for both UNII 1 and UNII 2A, begin SAR measurements in UNII 2A with the channel with the highest measured output power. If the reported SAR for UNII 2A is  $\leq 1.2$  W/kg, SAR is not required for UNII 1; otherwise treat the remaining bands separately and test them independently for SAR.
- When the specified maximum output power is different between UNII 1 and UNII 2A, begin SAR with the band that has the higher specified maximum output. If the highest reported SAR for the band with the highest specified power is  $\leq 1.2$  W/kg, testing for the band with the lower specified output power is not required; otherwise test the remaining bands independently for SAR.

To determine the initial test position, Area Scans were performed to determine the position with the Maximum Value of SAR (measured). The position that produced the highest Maximum Value of SAR is considered the worst case position; thus used as the initial test position.



## 6.8 Conducted Power

Band	Modulation	Sub-test	CH	Frequency (MHz)	Burst Average Power (dBm)
WCDMA Band II	RMC12.2K	---	Lowest	1852.4	20.37
			Middle	1880.0	20.49
			Highest	1907.6	20.46
HSDPA Band II	QPSK	1	Lowest	1852.4	20.38
			Middle	1880.0	20.41
			Highest	1907.6	20.44
		2	Lowest	1852.4	20.33
			Middle	1880.0	20.34
			Highest	1907.6	20.37
		3	Lowest	1852.4	19.91
			Middle	1880.0	19.97
			Highest	1907.6	20.03
		4	Lowest	1852.4	19.86
			Middle	1880.0	19.89
			Highest	1907.6	19.94
HSUPA Band II	QPSK	1	Lowest	1852.4	19.71
			Middle	1880.0	19.80
			Highest	1907.6	19.87
		2	Lowest	1852.4	17.70
			Middle	1880.0	17.79
			Highest	1907.6	17.86
		3	Lowest	1852.4	18.69
			Middle	1880.0	18.78
			Highest	1907.6	18.85
		4	Lowest	1852.4	17.68
			Middle	1880.0	17.77
			Highest	1907.6	17.84
		5	Lowest	1852.4	20.31
			Middle	1880.0	20.32
			Highest	1907.6	20.34





Band	Modulation	Sub-test	CH	Frequency (MHz)	Burst Average Power (dBm)
WCDMA Band V	RMC12.2K	---	Lowest	826.4	23.32
			Middle	836.6	23.44
			Highest	846.6	23.48
HSDPA Band V	QPSK	1	Lowest	826.4	22.46
			Middle	836.6	22.56
			Highest	846.6	22.61
		2	Lowest	826.4	22.24
			Middle	836.6	22.39
			Highest	846.6	22.52
		3	Lowest	826.4	21.85
			Middle	836.6	21.96
			Highest	846.6	22.16
		4	Lowest	826.4	21.91
			Middle	836.6	22.05
			Highest	846.6	22.10
HSUPA Band V	QPSK	1	Lowest	826.4	21.87
			Middle	836.6	22.01
			Highest	846.6	22.06
		2	Lowest	826.4	19.82
			Middle	836.6	20.03
			Highest	846.6	20.01
		3	Lowest	826.4	20.81
			Middle	836.6	20.92
			Highest	846.6	21.04
		4	Lowest	826.4	19.75
			Middle	836.6	19.96
			Highest	846.6	19.93
		5	Lowest	826.4	21.79
			Middle	836.6	21.82
			Highest	846.6	21.92



Band	Channel Bandwidth	Modulation	Channel	Frequency (MHz)	RB Configuration		Average Power	
					Size	Offset	(dBm)	(W)
LTE Band2	1.4 MHz	QPSK	18607	1850.7	1	0	20.63	0.116
					1	2	20.79	0.120
					1	5	20.65	0.116
					3	0	20.58	0.114
					3	1	20.52	0.113
					3	3	20.61	0.115
			6	0	20.00	0.100		
			18900	1880.0	1	0	20.78	0.120
					1	2	21.09	0.129
					1	5	20.86	0.122
					3	0	21.01	0.126
					3	1	21.05	0.127
					3	3	21.14	0.130
			19193	1909.3	6	0	20.01	0.100
					1	0	20.88	0.122
					1	2	<b>21.29</b>	<b>0.135</b>
					1	5	21.23	0.133
					3	0	21.11	0.129
		3			1	21.11	0.129	
		16QAM	18607	1850.7	3	3	21.18	0.131
					6	0	20.13	0.103
					1	0	19.97	0.099
					1	2	20.08	0.102
					1	5	19.87	0.097
					3	0	20.23	0.105
			18900	1880.0	3	1	20.17	0.104
					3	3	20.16	0.104
					6	0	18.93	0.078
					1	0	20.35	0.108
					1	2	<b>20.56</b>	<b>0.114</b>
					1	5	20.07	0.102
			19193	1909.3	3	0	20.42	0.110
					3	1	20.46	0.111
					3	3	20.52	0.113
					6	0	19.08	0.081
					1	0	20.29	0.107
1	2				20.42	0.110		
19193	1909.3	1	5	20.08	0.102			
		3	0	20.31	0.107			
		3	1	20.40	0.110			
		3	3	20.39	0.109			
		6	0	19.14	0.082			
		6	0	19.14	0.082			



Band	Channel Bandwidth	Modulation	Channel	Frequency (MHz)	RB Configuration		Average Power	
					Size	Offset	(dBm)	(W)
LTE Band2	3 MHz	QPSK	18615	1851.5	1	0	20.75	0.119
					1	7	20.87	0.122
					1	14	20.94	0.124
					8	0	19.90	0.098
					8	3	19.95	0.099
					8	7	19.91	0.098
			15	0	19.86	0.097		
			1	0	20.87	0.122		
			1	7	21.01	0.126		
			1	14	21.03	0.127		
			8	0	19.98	0.100		
			8	3	19.88	0.097		
			8	7	19.96	0.099		
			15	0	19.88	0.097		
			1	0	20.89	0.123		
			1	7	21.06	0.128		
			1	14	<b>21.08</b>	<b>0.128</b>		
			8	0	20.00	0.100		
		8	3	20.05	0.101			
		8	7	20.03	0.101			
		15	0	20.02	0.100			
		1	0	19.95	0.099			
		1	7	19.77	0.095			
		1	14	19.92	0.098			
		8	0	18.82	0.076			
		8	3	18.86	0.077			
		8	7	18.81	0.076			
		15	0	18.88	0.077			
		1	0	20.13	0.103			
		1	7	20.31	0.107			
		1	14	20.19	0.104			
		8	0	18.87	0.077			
		8	3	18.81	0.076			
		8	7	18.86	0.077			
		15	0	18.89	0.077			
		1	0	<b>20.46</b>	<b>0.111</b>			
1	7	19.99	0.100					
1	14	20.06	0.101					
8	0	18.99	0.079					
8	3	19.02	0.080					
8	7	19.03	0.080					
15	0	18.95	0.079					



Band	Channel Bandwidth	Modulation	Channel	Frequency (MHz)	RB Configuration		Average Power	
					Size	Offset	(dBm)	(W)
LTE Band2	5 MHz	QPSK	18625	1852.5	1	0	20.46	0.111
					1	12	20.57	0.114
					1	24	20.75	0.119
					12	0	19.76	0.095
					12	6	19.73	0.094
					12	13	19.76	0.095
			25	0	19.76	0.095		
			18900	1880.0	1	0	20.83	0.121
			1	12	20.82	0.121		
			1	24	20.89	0.123		
			12	0	19.85	0.097		
			12	6	19.86	0.097		
			12	13	19.83	0.096		
			25	0	19.77	0.095		
			19175	1907.5	1	0	20.83	0.121
			1	12	20.96	0.125		
			1	24	<b>21.01</b>	<b>0.126</b>		
			12	0	19.98	0.100		
			12	6	19.89	0.097		
			12	13	19.95	0.099		
			25	0	19.99	0.100		
			18625	1852.5	1	0	19.91	0.098
			1	12	19.69	0.093		
			1	24	19.88	0.097		
		12	0	18.83	0.076			
		12	6	18.81	0.076			
		12	13	18.87	0.077			
		25	0	18.89	0.077			
		18900	1880.0	1	0	20.02	0.100	
		1	12	19.72	0.094			
		1	24	19.89	0.097			
		12	0	18.84	0.077			
		12	6	18.86	0.077			
		12	13	18.83	0.076			
		25	0	18.82	0.076			
		19175	1907.5	1	0	<b>20.02</b>	<b>0.100</b>	
		1	12	19.81	0.096			
		1	24	20.01	0.100			
		12	0	18.86	0.077			
		12	6	18.95	0.079			
		12	11	18.89	0.077			
		25	0	19.04	0.080			



Band	Channel Bandwidth	Modulation	Channel	Frequency (MHz)	RB Configuration		Average Power	
					Size	Offset	(dBm)	(W)
LTE Band2	10 MHz	QPSK	18650	1855.0	1	0	20.78	0.120
					1	24	20.79	0.120
					1	49	20.64	0.116
					25	0	19.74	0.094
					25	12	19.64	0.092
					25	25	19.71	0.094
			50	0	19.66	0.092		
			1	0	20.88	0.122		
			1	24	20.86	0.122		
			1	49	20.84	0.121		
			25	0	19.84	0.096		
			25	12	19.75	0.094		
			25	25	19.77	0.095		
			50	0	19.81	0.096		
			1	0	20.81	0.121		
			1	24	<b>20.97</b>	<b>0.125</b>		
			1	49	20.89	0.123		
			25	0	19.87	0.097		
			25	12	19.84	0.096		
			25	25	19.94	0.099		
			50	0	19.83	0.096		
			1	0	19.94	0.099		
			1	24	19.93	0.098		
			1	49	19.73	0.094		
		25	0	18.88	0.077			
		25	12	18.88	0.077			
		25	25	18.85	0.077			
		50	0	18.89	0.077			
		1	0	20.10	0.102			
		1	24	19.93	0.098			
		1	49	20.09	0.102			
		25	0	18.86	0.077			
		25	12	18.83	0.076			
		25	25	18.88	0.077			
		50	0	18.81	0.076			
		1	0	20.09	0.102			
		1	24	<b>20.12</b>	<b>0.103</b>			
		1	49	20.06	0.101			
		25	0	18.82	0.076			
		25	12	18.88	0.077			
		25	25	18.99	0.079			
		50	0	18.83	0.076			



Band	Channel Bandwidth	Modulation	Channel	Frequency (MHz)	RB Configuration		Average Power		
					Size	Offset	(dBm)	(W)	
LTE Band2	15 MHz	QPSK	18675	1857.5	1	0	20.49	0.112	
					1	37	20.50	0.112	
					1	74	20.70	0.117	
					36	0	19.65	0.092	
					36	19	19.53	0.090	
					36	39	19.64	0.092	
			75	0	19.61	0.091			
			75	0	19.61	0.091			
			18900	1880.0	1	0	20.69	0.117	
					1	37	20.65	0.116	
					1	74	<b>20.88</b>	<b>0.122</b>	
					36	0	19.76	0.095	
					36	19	19.70	0.093	
					36	39	19.66	0.092	
			75	0	19.67	0.093			
			19125	1902.5	1	0	20.80	0.120	
					1	37	20.65	0.116	
					1	74	20.83	0.121	
		36			0	19.75	0.094		
		36			19	19.71	0.094		
		36			39	19.89	0.097		
		75	0	19.75	0.094				
		16QAM	15 MHz	18675	1857.5	1	0	19.94	0.099
						1	37	19.83	0.096
						1	74	19.83	0.096
						36	0	18.86	0.077
						36	19	18.83	0.076
						36	39	18.85	0.077
				75	0	18.82	0.076		
				75	0	18.82	0.076		
				18900	1880.0	1	0	<b>20.15</b>	<b>0.104</b>
						1	37	19.59	0.091
						1	74	19.94	0.099
						36	0	18.82	0.076
						36	19	18.83	0.076
						36	39	18.89	0.077
75	0			18.81	0.076				
19125	1902.5			1	0	19.98	0.100		
				1	37	19.75	0.094		
				1	74	20.12	0.103		
		36	0	18.83	0.076				
		36	19	18.85	0.077				
		36	39	18.94	0.078				
75	0	18.82	0.076						



Band	Channel Bandwidth	Modulation	Channel	Frequency (MHz)	RB Configuration		Average Power	
					Size	Offset	(dBm)	(W)
LTE Band2	20 MHz	QPSK	18700	1860.0	1	0	20.83	0.121
					1	49	20.65	0.116
					1	99	20.82	0.121
					50	0	19.71	0.094
					50	25	19.65	0.092
					50	50	19.66	0.092
			100	0	19.70	0.093		
			1	0	20.81	0.121		
			1	49	20.69	0.117		
			1	99	20.63	0.116		
			50	0	19.75	0.094		
			50	25	19.75	0.094		
			50	50	19.76	0.095		
			100	0	19.80	0.095		
			1	0	<b>20.85</b>	<b>0.122</b>		
			1	49	20.79	0.120		
			1	99	20.71	0.118		
			50	0	19.83	0.096		
			50	25	19.62	0.092		
			50	50	19.75	0.094		
			100	0	19.78	0.095		
			1	0	20.10	0.102		
			1	49	19.88	0.097		
			1	99	19.83	0.096		
		50	0	19.86	0.097			
		50	25	19.66	0.092			
		50	50	19.69	0.093			
		100	0	19.58	0.091			
		1	0	20.11	0.103			
		1	49	20.02	0.100			
		1	99	19.93	0.098			
		50	0	19.47	0.089			
		50	25	19.53	0.090			
		50	50	19.59	0.091			
		100	0	19.29	0.085			
		1	0	20.14	0.103			
		1	49	20.11	0.103			
		1	99	<b>20.29</b>	<b>0.107</b>			
		50	0	19.88	0.097			
		50	25	19.85	0.097			
		50	50	19.86	0.097			
		100	0	19.83	0.096			



Band	Channel Bandwidth	Modulation	Channel	Frequency (MHz)	RB Configuration		Average Power	
					Size	Offset	(dBm)	(W)
LTE Band4	1.4 MHz	QPSK	19957	1710.7	1	0	23.20	0.209
					1	2	23.18	0.208
					1	5	23.13	0.206
					3	0	22.99	0.199
					3	1	23.02	0.200
					3	3	23.19	0.208
			6	0	22.11	0.163		
			1	0	23.05	0.202		
			1	2	<b>23.21</b>	<b>0.209</b>		
			1	5	23.08	0.203		
			3	0	23.13	0.206		
			3	1	23.16	0.207		
			3	3	23.10	0.204		
			6	0	22.12	0.163		
			1	0	22.85	0.193		
			1	2	22.96	0.198		
			1	5	22.82	0.191		
			3	0	22.84	0.192		
		3	1	22.87	0.194			
		3	3	22.80	0.191			
		6	0	21.93	0.156			
		1	0	22.08	0.161			
		1	2	22.04	0.160			
		1	5	22.34	0.171			
		3	0	21.56	0.143			
		3	1	21.38	0.137			
		3	3	21.30	0.135			
		6	0	20.57	0.114			
		1	0	22.12	0.163			
		1	2	22.25	0.168			
		1	5	<b>22.37</b>	<b>0.173</b>			
		3	0	21.73	0.149			
		3	1	21.70	0.148			
		3	3	21.60	0.145			
		6	0	20.58	0.114			
		1	0	22.07	0.161			
1	2	22.32	0.171					
1	5	22.18	0.165					
3	0	22.04	0.160					
3	1	22.19	0.166					
3	3	22.16	0.164					
6	0	21.24	0.133					





Band	Channel Bandwidth	Modulation	Channel	Frequency (MHz)	RB Configuration		Average Power	
					Size	Offset	(dBm)	(W)
LTE Band4	3 MHz	QPSK	19965	1711.5	1	0	<b>23.22</b>	<b>0.210</b>
					1	7	23.07	0.203
					1	14	23.09	0.204
					8	0	22.13	0.163
					8	3	22.12	0.163
					8	7	21.99	0.158
			15	0	22.13	0.163		
			1	0	23.13	0.206		
			1	7	23.00	0.200		
			1	14	23.03	0.201		
			8	0	22.18	0.165		
			8	3	22.18	0.165		
			8	7	22.04	0.160		
			15	0	22.12	0.163		
			1	0	22.95	0.197		
			1	7	22.79	0.190		
			1	14	22.90	0.195		
			8	0	21.97	0.157		
			8	3	21.99	0.158		
			8	7	21.89	0.155		
			15	0	21.88	0.154		
			1	0	<b>22.27</b>	<b>0.169</b>		
			1	7	22.15	0.164		
			1	14	22.22	0.167		
		8	0	21.24	0.133			
		8	3	21.20	0.132			
		8	7	21.10	0.129			
		15	0	21.07	0.128			
		1	0	22.17	0.165			
		1	7	22.19	0.166			
		1	14	22.22	0.167			
		8	0	20.98	0.125			
		8	3	20.89	0.123			
		8	7	20.70	0.117			
		15	0	21.14	0.130			
		1	0	22.21	0.166			
		1	7	22.17	0.165			
		1	14	22.14	0.164			
		8	0	20.90	0.123			
		8	3	20.83	0.121			
		8	7	20.84	0.121			
		15	0	20.84	0.121			



Band	Channel Bandwidth	Modulation	Channel	Frequency (MHz)	RB Configuration		Average Power	
					Size	Offset	(dBm)	(W)
LTE Band4	5 MHz	QPSK	19975	1712.5	1	0	23.06	0.202
					1	12	22.80	0.191
					1	24	22.99	0.199
					12	0	22.12	0.163
					12	6	21.98	0.158
					12	13	22.07	0.161
			25	0	22.07	0.161		
			1	0	<b>23.26</b>	<b>0.212</b>		
			1	12	22.87	0.194		
			1	24	23.00	0.200		
			12	0	22.05	0.160		
			12	6	22.03	0.160		
			12	13	22.09	0.162		
			25	0	22.11	0.163		
			1	0	22.85	0.193		
			1	12	22.72	0.187		
			1	24	22.87	0.194		
			12	0	21.81	0.152		
			12	6	21.85	0.153		
			12	13	21.98	0.158		
			25	0	21.84	0.153		
			1	0	22.00	0.158		
			1	12	21.74	0.149		
			1	24	22.10	0.162		
		12	0	20.93	0.124			
		12	6	20.81	0.121			
		12	13	21.03	0.127			
		25	0	21.12	0.129			
		1	0	<b>22.32</b>	<b>0.171</b>			
		1	12	21.89	0.155			
		1	24	22.18	0.165			
		12	0	21.24	0.133			
		12	6	21.15	0.130			
		12	13	21.20	0.132			
		25	0	21.24	0.133			
		1	0	22.08	0.161			
		1	12	21.86	0.153			
		1	24	22.13	0.163			
		12	0	20.86	0.122			
		12	6	20.80	0.120			
		12	11	20.82	0.121			
		25	0	20.89	0.123			



Band	Channel Bandwidth	Modulation	Channel	Frequency (MHz)	RB Configuration		Average Power	
					Size	Offset	(dBm)	(W)
LTE Band4	10 MHz	QPSK	20000	1715.0	1	0	<b>23.34</b>	<b>0.216</b>
					1	24	23.29	0.213
					1	49	23.20	0.209
					25	0	22.18	0.165
					25	12	22.09	0.162
					25	25	22.13	0.163
			50	0	22.15	0.164		
			1	0	23.31	0.214		
			1	24	23.26	0.212		
			1	49	23.09	0.204		
			25	0	22.26	0.168		
			25	12	22.07	0.161		
			25	25	22.05	0.160		
			50	0	22.11	0.163		
			1	0	23.00	0.200		
			1	24	22.93	0.196		
			1	49	22.82	0.191		
			25	0	22.02	0.159		
		25	12	21.89	0.155			
		25	25	21.95	0.157			
		50	0	21.84	0.153			
		1	0	22.13	0.163			
		1	24	22.39	0.173			
		1	49	<b>22.45</b>	<b>0.176</b>			
		25	0	20.67	0.117			
		25	12	20.55	0.114			
		25	25	20.56	0.114			
		50	0	20.66	0.116			
		1	0	22.27	0.169			
		1	24	22.39	0.173			
		1	49	22.17	0.165			
		25	0	20.74	0.119			
		25	12	20.56	0.114			
		25	25	20.54	0.113			
		50	0	20.65	0.116			
		1	0	21.79	0.151			
1	24	22.16	0.164					
1	49	22.05	0.160					
25	0	20.61	0.115					
25	12	20.50	0.112					
25	25	20.55	0.114					
50	0	20.45	0.111					



Band	Channel Bandwidth	Modulation	Channel	Frequency (MHz)	RB Configuration		Average Power	
					Size	Offset	(dBm)	(W)
LTE Band4	15 MHz	QPSK	20025	1717.5	1	0	23.44	0.221
					1	37	23.00	0.200
					1	74	23.33	0.215
					36	0	22.18	0.165
					36	19	22.09	0.162
					36	39	22.16	0.164
			75	0	22.08	0.161		
			75	0	<b>23.48</b>	<b>0.223</b>		
			1	37	23.00	0.200		
			1	74	23.03	0.201		
			36	0	22.25	0.168		
			36	19	22.07	0.161		
			36	39	22.09	0.162		
			75	0	22.13	0.163		
			1	0	23.14	0.206		
			1	37	22.73	0.187		
			1	74	23.05	0.202		
			36	0	22.08	0.161		
			36	19	21.96	0.157		
			36	39	21.93	0.156		
			75	0	21.98	0.158		
			1	0	22.61	0.182		
			1	37	22.46	0.176		
			1	74	22.35	0.172		
		36	0	20.98	0.125			
		36	19	20.86	0.122			
		36	39	20.91	0.123			
		75	0	21.14	0.130			
		1	0	22.47	0.177			
		1	37	22.50	0.178			
		1	74	22.45	0.176			
		36	0	21.29	0.135			
		36	19	20.96	0.125			
		36	39	21.01	0.126			
		75	0	21.11	0.129			
		1	0	22.46	0.176			
		1	37	22.51	0.178			
		1	74	<b>22.68</b>	<b>0.185</b>			
		36	0	20.96	0.125			
		36	19	20.84	0.121			
		36	39	21.07	0.128			
		75	0	21.04	0.127			



Band	Channel Bandwidth	Modulation	Channel	Frequency (MHz)	RB Configuration		Average Power	
					Size	Offset	(dBm)	(W)
LTE Band4	20 MHz	QPSK	20050	1720.0	1	0	23.47	0.222
					1	49	23.55	0.226
					1	99	23.33	0.215
					50	0	22.28	0.169
					50	25	22.15	0.164
					50	50	22.14	0.164
			100	0	22.19	0.166		
			1	0	<b>23.56</b>	<b>0.227</b>		
			1	49	23.20	0.209		
			1	99	22.99	0.199		
			50	0	22.37	0.173		
			50	25	22.16	0.164		
			50	50	22.00	0.158		
			100	0	22.16	0.164		
			1	0	23.18	0.208		
			1	49	22.81	0.191		
			1	99	23.02	0.200		
			50	0	22.10	0.162		
		50	25	22.01	0.159			
		50	50	22.05	0.160			
		100	0	22.06	0.161			
		1	0	22.40	0.174			
		1	49	22.26	0.168			
		1	99	22.49	0.177			
		50	0	21.43	0.139			
		50	25	21.31	0.135			
		50	50	21.33	0.136			
		100	0	21.47	0.140			
		1	0	22.54	0.179			
		1	49	22.32	0.171			
		1	99	21.91	0.155			
		50	0	21.61	0.145			
		50	25	21.38	0.137			
		50	50	21.34	0.136			
		100	0	21.37	0.137			
		1	0	<b>22.67</b>	<b>0.185</b>			
1	49	22.44	0.175					
1	99	22.61	0.182					
50	0	21.41	0.138					
50	25	21.22	0.132					
50	50	21.24	0.133					
100	0	21.28	0.134					



Band	Channel Bandwidth	Modulation	Channel	Frequency (MHz)	RB Configuration		Average Power	
					Size	Offset	(dBm)	(W)
LTE Band5	1.4 MHz	QPSK	20407	824.7	1	0	22.97	0.198
					1	2	23.11	0.205
					1	5	22.89	0.195
					3	0	23.08	0.203
					3	1	23.09	0.204
					3	3	22.96	0.198
			6	0	22.11	0.163		
			20525	836.5	1	0	23.10	0.204
					1	2	<b>23.15</b>	<b>0.207</b>
					1	5	23.04	0.201
					3	0	23.02	0.200
					3	1	22.93	0.196
					3	3	22.87	0.194
			20643	848.3	6	0	22.13	0.163
					1	0	23.00	0.200
					1	2	22.99	0.199
					1	5	22.84	0.192
					3	0	23.10	0.204
		3			1	22.98	0.199	
		16QAM	20407	824.7	3	3	22.90	0.195
					6	0	22.16	0.164
					1	0	22.17	0.165
					1	2	22.14	0.164
					1	5	22.28	0.169
					3	0	21.97	0.157
			20525	836.5	3	1	21.98	0.158
					3	3	21.95	0.157
					6	0	20.61	0.115
					1	0	22.20	0.166
					1	2	<b>22.31</b>	<b>0.170</b>
					1	5	22.20	0.166
			20643	848.3	3	0	21.55	0.143
					3	1	21.63	0.146
					3	3	21.52	0.142
					6	0	20.52	0.113
					1	0	22.05	0.160
					1	2	22.10	0.162
		20643	848.3	1	5	21.85	0.153	
				3	0	22.05	0.160	
				3	1	22.05	0.160	
				3	3	21.92	0.156	
				6	0	21.18	0.131	
6	0			21.18	0.131			



Band	Channel Bandwidth	Modulation	Channel	Frequency (MHz)	RB Configuration		Average Power	
					Size	Offset	(dBm)	(W)
LTE Band5	3 MHz	QPSK	20415	825.5	1	0	23.08	0.203
					1	7	22.96	0.198
					1	14	23.09	0.204
					8	0	22.06	0.161
					8	3	22.07	0.161
					8	7	22.15	0.164
			15	0	21.99	0.158		
			1	0	23.10	0.204		
			1	7	22.71	0.187		
			1	14	22.97	0.198		
			8	0	22.04	0.160		
			8	3	22.02	0.159		
			8	7	22.01	0.159		
			15	0	21.93	0.156		
			1	0	<b>23.17</b>	<b>0.207</b>		
			1	7	22.88	0.194		
			1	14	22.94	0.197		
			8	0	21.92	0.156		
			8	3	21.95	0.157		
			8	7	21.98	0.158		
			15	0	22.03	0.160		
			1	0	22.09	0.162		
			1	7	22.16	0.164		
			1	14	22.29	0.169		
		8	0	20.64	0.116			
		8	3	20.47	0.111			
		8	7	20.43	0.110			
		15	0	20.56	0.114			
		1	0	22.27	0.169			
		1	7	22.13	0.163			
		1	14	<b>22.34</b>	<b>0.171</b>			
		8	0	20.73	0.118			
		8	3	20.69	0.117			
		8	7	20.80	0.120			
		15	0	20.62	0.115			
		1	0	22.03	0.160			
		1	7	21.66	0.147			
		1	14	21.81	0.152			
		8	0	20.76	0.119			
		8	3	20.67	0.117			
		8	7	20.56	0.114			
		15	0	20.64	0.116			



Band	Channel Bandwidth	Modulation	Channel	Frequency (MHz)	RB Configuration		Average Power	
					Size	Offset	(dBm)	(W)
LTE Band5	5 MHz	QPSK	20425	826.5	1	0	22.97	0.198
					1	12	22.75	0.188
					1	24	22.99	0.199
					12	0	22.07	0.161
					12	6	21.92	0.156
					12	13	22.11	0.163
			25	0	22.14	0.164		
			25	0	22.14	0.164		
			20525	836.5	1	0	23.04	0.201
					1	12	22.71	0.187
					1	24	<b>23.20</b>	<b>0.209</b>
					12	0	21.95	0.157
					12	6	21.95	0.157
					12	13	21.98	0.158
			25	0	22.04	0.160		
			20625	846.5	1	0	23.06	0.202
					1	12	22.84	0.192
					1	24	23.18	0.208
		12			0	22.15	0.164	
		12			6	22.02	0.159	
		12			13	22.13	0.163	
		25	0	22.10	0.162			
		16QAM	20425	826.5	1	0	22.14	0.164
					1	12	21.78	0.151
					1	24	22.11	0.163
					12	0	21.19	0.132
					12	6	21.02	0.126
					12	13	21.15	0.130
			25	0	21.20	0.132		
			20525	836.5	1	0	<b>22.40</b>	<b>0.174</b>
					1	12	21.96	0.157
					1	24	22.16	0.164
					12	0	21.21	0.132
					12	6	21.17	0.131
					12	13	21.24	0.133
			25	0	21.18	0.131		
			20625	846.5	1	0	22.38	0.173
					1	12	21.84	0.153
					1	24	22.13	0.163
					12	0	21.13	0.130
		12			6	21.00	0.126	
		12			11	21.12	0.129	
		25	0	21.19	0.132			





Band	Channel Bandwidth	Modulation	Channel	Frequency (MHz)	RB Configuration		Average Power	
					Size	Offset	(dBm)	(W)
LTE Band5	10 MHz	QPSK	20450	829.0	1	0	23.19	0.208
					1	24	22.92	0.196
					1	49	22.97	0.198
					25	0	22.13	0.163
					25	12	21.98	0.158
					25	25	21.98	0.158
			50	0	22.12	0.163		
			1	0	<b>23.24</b>	<b>0.211</b>		
			1	24	22.87	0.194		
			1	49	22.86	0.193		
			25	0	22.13	0.163		
			25	12	22.05	0.160		
			25	25	22.01	0.159		
			50	0	22.09	0.162		
			1	0	23.10	0.204		
			1	24	22.90	0.195		
			1	49	22.85	0.193		
			25	0	22.05	0.160		
		25	12	22.02	0.159			
		25	25	22.00	0.158			
		50	0	22.06	0.161			
		1	0	22.24	0.167			
		1	24	22.06	0.161			
		1	49	21.92	0.156			
		25	0	20.81	0.121			
		25	12	20.60	0.115			
		25	25	20.60	0.115			
		50	0	20.81	0.121			
		1	0	22.22	0.167			
		1	24	22.21	0.166			
		1	49	22.27	0.169			
		25	0	21.00	0.126			
		25	12	20.82	0.121			
		25	25	20.76	0.119			
		50	0	20.74	0.119			
		1	0	<b>22.44</b>	<b>0.175</b>			
1	24	22.32	0.171					
1	49	22.44	0.175					
25	0	20.87	0.122					
25	12	20.71	0.118					
25	25	20.70	0.117					
50	0	20.86	0.122					



Band	Channel Bandwidth	Modulation	Channel	Frequency (MHz)	RB Configuration		Average Power	
					Size	Offset	(dBm)	(W)
LTE Band12	1.4 MHz	QPSK	23017	699.7	1	0	22.88	0.194
					1	2	23.09	0.204
					1	5	23.14	0.206
					3	0	23.02	0.200
					3	1	22.97	0.198
					3	3	23.04	0.201
			6	0	22.17	0.165		
			6	0	<b>23.20</b>	<b>0.209</b>		
			1	2	23.13	0.206		
			1	5	23.10	0.204		
			3	0	23.10	0.204		
			3	1	23.15	0.207		
			3	3	23.12	0.205		
			6	0	22.19	0.166		
			1	0	23.08	0.203		
			1	2	23.00	0.200		
			1	5	23.08	0.203		
			3	0	23.04	0.201		
		3	1	23.03	0.201			
		3	3	23.05	0.202			
		6	0	22.23	0.167			
		1	0	22.03	0.160			
		1	2	22.24	0.167			
		1	5	<b>22.37</b>	<b>0.173</b>			
		3	0	21.63	0.146			
		3	1	21.60	0.145			
		3	3	21.61	0.145			
		6	0	20.96	0.125			
		1	0	22.04	0.160			
		1	2	22.06	0.161			
		1	5	22.03	0.160			
		3	0	21.60	0.145			
		3	1	21.82	0.152			
		3	3	21.84	0.153			
		6	0	20.84	0.121			
		1	0	21.90	0.155			
		1	2	22.01	0.159			
		1	5	22.32	0.171			
		3	0	21.91	0.155			
		3	1	22.23	0.167			
		3	3	22.09	0.162			
		6	0	20.98	0.125			



Band	Channel Bandwidth	Modulation	Channel	Frequency (MHz)	RB Configuration		Average Power	
					Size	Offset	(dBm)	(W)
LTE Band12	3 MHz	QPSK	23025	700.5	1	0	23.01	0.200
					1	7	22.88	0.194
					1	14	22.90	0.195
					8	0	22.05	0.160
					8	3	22.02	0.159
					8	7	21.96	0.157
			15	0	22.01	0.159		
			1	0	23.07	0.203		
			1	7	22.85	0.193		
			1	14	23.02	0.200		
			8	0	22.09	0.162		
			8	3	22.04	0.160		
			8	7	21.97	0.157		
			15	0	22.01	0.159		
			1	0	23.20	0.209		
			1	7	23.22	0.210		
			1	14	<b>23.24</b>	<b>0.211</b>		
			8	0	22.09	0.162		
		8	3	22.07	0.161			
		8	7	22.01	0.159			
		15	0	22.07	0.161			
		1	0	22.32	0.171			
		1	7	22.28	0.169			
		1	14	<b>22.35</b>	<b>0.172</b>			
		8	0	20.84	0.121			
		8	3	20.68	0.117			
		8	7	20.58	0.114			
		15	0	20.67	0.117			
		1	0	22.24	0.167			
		1	7	22.23	0.167			
		1	14	22.13	0.163			
		8	0	20.86	0.122			
		8	3	20.66	0.116			
		8	7	20.64	0.116			
		15	0	20.77	0.119			
		1	0	22.19	0.166			
1	7	22.07	0.161					
1	14	22.04	0.160					
8	0	20.82	0.121					
8	3	20.74	0.119					
8	7	20.79	0.120					
15	0	20.77	0.119					



Band	Channel Bandwidth	Modulation	Channel	Frequency (MHz)	RB Configuration		Average Power			
					Size	Offset	(dBm)	(W)		
LTE Band12	5 MHz	QPSK	23035	701.5	1	0	22.76	0.189		
					1	12	22.76	0.189		
					1	24	22.92	0.196		
					12	0	21.95	0.157		
					12	6	21.94	0.156		
					12	13	22.02	0.159		
			25	0	21.89	0.155				
			23095	707.5	1	0	22.96	0.198		
			1		12	23.05	0.202			
			1		24	22.97	0.198			
			12		0	21.89	0.155			
			12		6	21.89	0.155			
			12		13	22.02	0.159			
			25	0	21.99	0.158				
			23155	713.5	1	0	22.93	0.196		
			1		12	22.86	0.193			
			1		24	<b>23.23</b>	<b>0.210</b>			
			12		0	22.08	0.161			
			12		6	22.11	0.163			
			12		13	22.10	0.162			
			25	0	22.01	0.159				
			16QAM	23035	701.5	1	0	21.87	0.154	
						1	12	21.70	0.148	
						1	24	21.91	0.155	
		12				0	21.02	0.126		
		12				6	20.75	0.119		
		12				13	20.80	0.120		
		25				0	20.91	0.123		
		23095				707.5	1	0	21.96	0.157
							1	12	22.31	0.170
							1	24	<b>22.33</b>	<b>0.171</b>
							12	0	20.94	0.124
							12	6	20.80	0.120
				12	13		20.84	0.121		
		25		0	21.01	0.126				
		23155		713.5	1	0	21.96	0.157		
					1	12	21.89	0.155		
					1	24	22.18	0.165		
					12	0	20.97	0.125		
					12	6	21.05	0.127		
					12	11	21.06	0.128		
		25		0	21.06	0.128				



Band	Channel Bandwidth	Modulation	Channel	Frequency (MHz)	RB Configuration		Average Power	
					Size	Offset	(dBm)	(W)
LTE Band12	10 MHz	QPSK	23060	704.0	1	0	23.13	0.206
					1	24	23.11	0.205
					1	49	22.63	0.183
					25	0	21.81	0.152
					25	12	22.05	0.160
					25	25	21.99	0.158
			50	0	21.89	0.155		
			50	0	21.89	0.155		
			23095	707.5	1	0	22.86	0.193
					1	24	<b>23.25</b>	<b>0.211</b>
					1	49	22.60	0.182
					25	0	22.00	0.158
					25	12	21.90	0.155
					25	25	21.79	0.151
			50	0	21.88	0.154		
			23130	711.0	1	0	23.24	0.211
					1	24	23.10	0.204
					1	49	22.88	0.194
		25			0	22.08	0.161	
		25			12	21.94	0.156	
		25			25	21.97	0.157	
		50	0	22.10	0.162			
		16QAM	23060	704.0	1	0	22.08	0.161
					1	24	22.15	0.164
					1	49	22.22	0.167
					25	0	20.38	0.109
					25	12	20.63	0.116
					25	25	20.58	0.114
			50	0	20.61	0.115		
			23095	707.5	1	0	22.21	0.166
					1	24	22.22	0.167
					1	49	22.13	0.163
					25	0	20.72	0.118
					25	12	20.75	0.119
					25	25	20.75	0.119
			50	0	20.63	0.116		
23130	711.0		1	0	22.22	0.167		
			1	24	<b>22.27</b>	<b>0.169</b>		
			1	49	21.93	0.156		
			25	0	20.75	0.119		
		25	12	20.70	0.117			
		25	25	20.63	0.116			
50	0	20.79	0.120					



Band	Data Rate	CH	Frequency (MHz)	Average Power (dBm)
IEEE 802.11b	1 M	1	2412.0	12.10
		6	2437.0	12.50
		11	2462.0	<b>13.03</b>
IEEE 802.11g	6 M	1	2412.0	10.37
		6	2437.0	<b>12.49</b>
		11	2462.0	11.76
IEEE 802.11n 2.4 GHz 20 MHz	6.5 M	1	2412.0	9.39
		6	2437.0	<b>12.22</b>
		11	2462.0	10.59
IEEE 802.11n 2.4 GHz 40 MHz	13.5 M	3	2422.0	7.14
		6	2437.0	<b>12.15</b>
		9	2452.0	7.98
IEEE 802.11a	6 M	36	5180.0	12.23
		40	5200.0	12.08
		44	5220.0	12.51
		48	5240.0	<b>12.66</b>
		52	5260.0	<b>12.83</b>
		56	5280.0	12.42
		60	5300.0	12.56
		64	5320.0	12.53
		100	5500.0	12.23
		104	5520.0	12.31
		108	5540.0	12.28
		112	5560.0	12.18
		116	5580.0	12.87
		132	5660.0	12.58
		136	5680.0	12.60
		140	5700.0	<b>12.90</b>
		149	5745.0	<b>11.77</b>
		153	5765.0	11.36
157	5785.0	11.39		
161	5805.0	10.99		
165	5825.0	11.42		



Band	Data Rate	CH	Frequency (MHz)	Average Power (dBm)
IEEE 802.11n 5 GHz 20 MHz	6.5 M	36	5180.0	12.82
		40	5200.0	13.32
		44	5220.0	13.66
		48	5240.0	<b>13.68</b>
		52	5260.0	<b>13.74</b>
		56	5280.0	13.35
		60	5300.0	13.51
		64	5320.0	13.26
		100	5500.0	12.26
		104	5520.0	12.32
		108	5540.0	12.29
		112	5560.0	12.23
		116	5580.0	12.47
		132	5660.0	12.50
		136	5680.0	12.65
		140	5700.0	<b>13.06</b>
		149	5745.0	11.41
		153	5765.0	<b>11.42</b>
157	5785.0	11.33		
161	5805.0	11.05		
165	5825.0	10.41		
IEEE 802.11n 5 GHz 40 MHz	13.5 M	38	5190.0	12.38
		46	5230.0	<b>12.81</b>
		54	5270.0	<b>12.83</b>
		62	5310.0	12.76
		102	5510.0	10.20
		110	5550.0	10.19
		134	5670.0	<b>11.99</b>
		151	5755.0	10.22
		159	5795.0	<b>10.38</b>



Band	CH	Frequency (MHz)	Packet Type	Average Power (dBm)
Bluetooth BR GFSK	0	2402.0	DH1	5.09
			DH3	5.10
			DH5	5.14
	39	2441.0	DH1	5.05
			DH3	5.06
			DH5	5.08
	78	2480.0	DH1	5.52
			DH3	5.53
			DH5	<b>5.55</b>
Bluetooth EDR $\pi/4$ -DQPSK	0	2402.0	2DH1	3.23
			2DH3	3.24
			2DH5	3.28
	39	2441.0	2DH1	3.20
			2DH3	3.20
			2DH5	3.23
	78	2480.0	2DH1	3.65
			2DH3	3.65
			2DH5	<b>3.67</b>
Bluetooth EDR 8DPSK	0	2402.0	3DH1	3.23
			3DH3	3.25
			3DH5	3.28
	39	2441.0	3DH1	3.20
			3DH3	3.20
			3DH5	3.23
	78	2480.0	3DH1	3.65
			3DH3	3.66
			3DH5	<b>3.68</b>
Bluetooth LE	0	2402.0	---	0.84
	19	2440.0		0.86
	39	2480.0		<b>0.97</b>



## 6.9 Antenna location

Ant	Antenna to user distance (mm)				
	Back	Side 1	Side 2	Side 3	Side 4
WWAN ANT	5	28	202.5	95	20
WLAN ANT	5	126.5	200	22	32
Bluetooth ANT	5	126.5	200	22	32

Note : We use a minimum distance of 5 mm for back side.

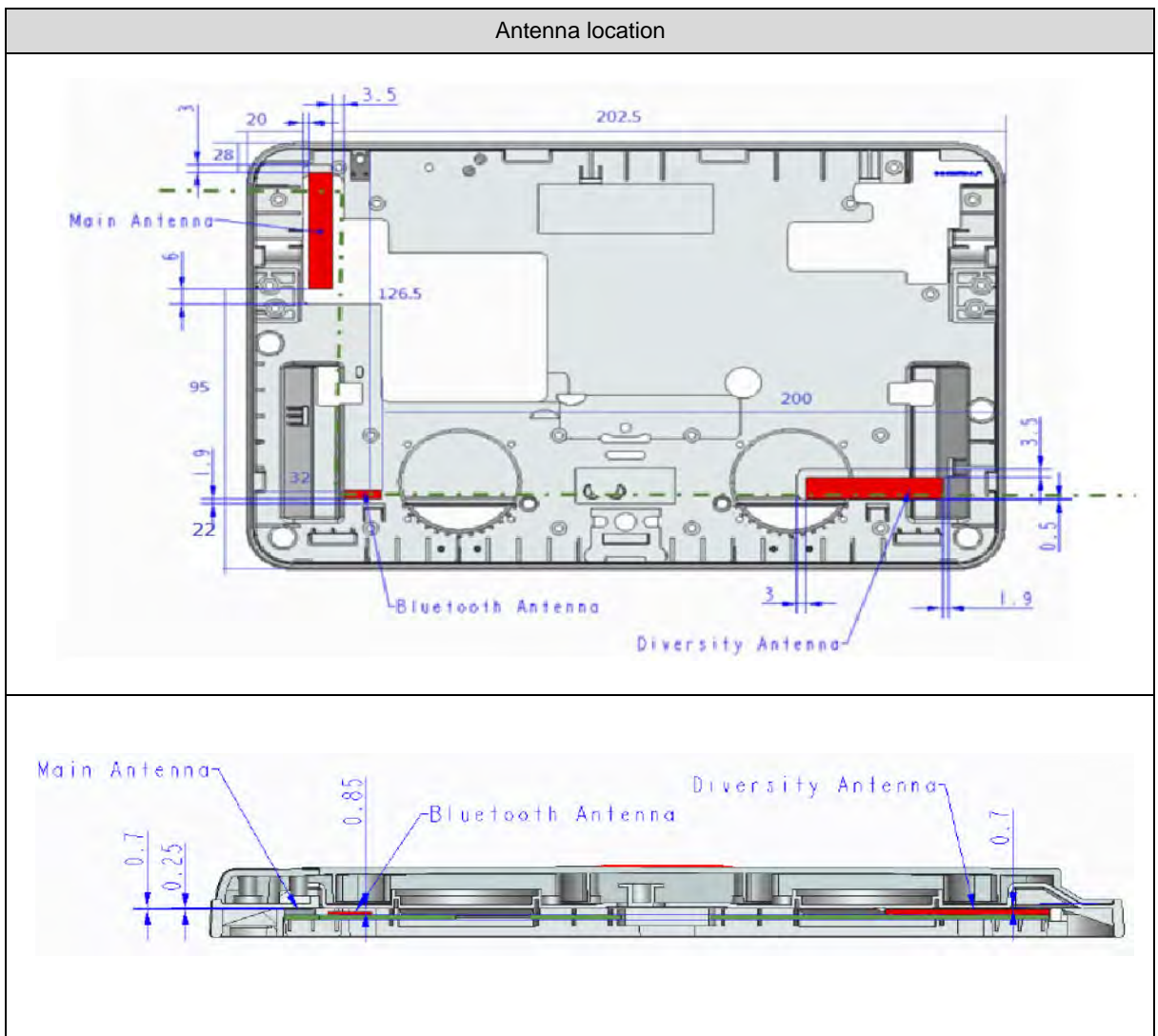



## 6.10 Standalone SAR Test Exclusion Calculation

Ant. Used	Band	Frequency	Tune-Power		Distance of Ant. To User (mm)				
		(GHz)	(dBm)	(mW)	Back	Side 1	Side 2	Side 3	Side 4
WWAN Antenna	WCDMA Band II	1.907	20.5	112	5	28	202.5	95	20
	WCDMA Band V	0.846	24.0	251	5	28	202.5	95	20
	LTE Band 2	1.909	21.4	138	5	28	202.5	95	20
	LTE Band 4	1.754	24.5	282	5	28	202.5	95	20
	LTE Band 5	0.848	24.5	282	5	28	202.5	95	20
	LTE Band 12	0.715	24.0	251	5	28	202.5	95	20
Bluetooth Antenna	BT	2.480	7.0	5	5	126.5	200	22	32
WLAN Antenna	WLAN 2.4 GHz	2.462	13.5	22	5	126.5	200	22	32
	WLAN 5 GHz	5.825	14.0	25	5	126.5	200	22	32

Ant. Used	Band	Frequency	Tune-Power		Calculated value and evaluated result					
		(GHz)	(dBm)	(mW)	Back	Side1	Side2	Side3	Side4	exclusion threshold
WWAN Antenna	WCDMA Band II	1.907	20.5	112	30.9	5.5	1634.0	559.0	7.7	3
					MEASURE	MEASURE	EXEMPT	EXEMPT	MEASURE	
	WCDMA Band V	0.846	24.0	251	46.2	8.3	1023.2mW	416.9mW	11.5	3
					MEASURE	MEASURE	EXEMPT	EXEMPT	MEASURE	
	LTE Band 2	1.909	21.4	138	38.1	6.8	1634.0	559.0	9.5	3
					MEASURE	MEASURE	EXEMPT	EXEMPT	MEASURE	
	LTE Band 4	1.754	24.5	282	74.7	13.3	1638.0	563.0	18.7	3
					MEASURE	MEASURE	EXEMPT	EXEMPT	MEASURE	
	LTE Band 5	0.848	24.5	282	51.9	9.3	1025mW	417.3mW	13.0	3
					MEASURE	MEASURE	EXEMPT	EXEMPT	MEASURE	
	LTE Band 12	0.715	24.0	251	42.5	7.6	904.3mW	391.9mW	10.6	3
					MEASURE	MEASURE	EXEMPT	EXEMPT	MEASURE	
Bluetooth Antenna	BT	2.480	7.0	5	1.6	860.0	1595.0	0.4	0.3	3
					EXEMPT	EXEMPT	EXEMPT	EXEMPT	EXEMPT	
WLAN Antenna	WLAN 2.4 GHz	2.462	13.5	22	6.9	861.0	1596.0	1.6	1.1	3
					MEASURE	EXEMPT	EXEMPT	EXEMPT	EXEMPT	
	WLAN 5 GHz	5.825	14.0	25	12.1	827.0	1562.0	2.7	1.9	3
					MEASURE	EXEMPT	EXEMPT	EXEMPT	EXEMPT	



Note:

1. The test reduction for distance less than 50 mm and more than 50 mm. Use the max power to make sure minimum distance by evaluated for SAR testing.
2. For 100 MHz to 6 GHz and test separation distances > 50 mm, According to KDB 447498, if the calculated Power threshold is less than the output power then SAR testing is required. Calculated Value include string "mW", that is mean through compare output power with threshold, if the output power more than threshold value the SAR test should be perform. Otherwise, the SAR test could be exempt. (> 50mm).
3. For 100 MHz to 6 GHz and test separation distances  $\leq$  50 mm, the 1-g and 10-g SAR test exclusion thresholds are determined by the following:  
According to KDB 447498, if the calculated threshold value are >3 then Body SAR and >7.5 then Limbs SAR testing are required. Calculated Value only include number format, that is mean through compare output power with threshold, if the Calculated value more than 3, the SAR test should be perform. Otherwise, the SAR test could be exempt. (<50 mm).
4. When an antenna qualifies for the standalone SAR test exclusion of KDB 447498 section 4.3.1 and also transmits simultaneously with other antennas, the standalone SAR value must be estimated according to KDB 447498 section "4.3.2. Simultaneous transmission SAR test exclusion considerations b)".
5. We used highest frequency and power, that result should be evaluated the worst case.
6. Power and distance are rounded to the nearest mW and mm before calculation.
7. The result is rounded to one decimal place for comparison.



## 6.11 Simultaneous Transmitting Evaluate

Simultaneous transmission configurations as below:

Condition	Frequency Band			
	WWAN ANT	WLAN 2.4 GHz ANT	WLAN 5 GHz ANT	Bluetooth ANT
1	V	V	V	V

### Estimated SAR

Ant. Used	Band	Frequency	Tune-Power		Estimated SAR 1-g (W/kg)				
		(GHz)	(dBm)	(mW)	Back	Side1	Side2	Side3	Side4
WWAN Antenna	WCDMA Band II	1.907	20.5	112	---	---	0.4	0.4	---
	WCDMA Band V	0.846	24.0	251	---	---	0.4	0.4	---
	LTE Band 2	1.909	21.4	138	---	---	0.4	0.4	---
	LTE Band 4	1.754	24.5	282	---	---	0.4	0.4	---
	LTE Band 5	0.848	24.5	282	---	---	0.4	0.4	---
	LTE Band 12	0.715	24.0	251	---	---	0.4	0.4	---
Bluetooth Antenna	BT	2.480	7.0	5	0.21	0.4	0.4	0.05	0.03
WLAN Antenna	WLAN 2.4 GHz	2.462	13.5	22	---	0.4	0.4	0.21	0.14
	WLAN 5 GHz	5.825	14.0	25	---	0.4	0.4	0.37	0.25



### 6.11.1 Sum of 1-g SAR of all simultaneously transmitting

When the sum of 1-g SAR of all simultaneously transmitting antennas in and operating mode and exposure condition combination is within the SAR limit, SAR test exclusion applies to that simultaneous transmission configuration.

Sum of 1-g SAR of summary as below:

Phantom Position		Spacing (mm)	ASSY	WWAN ANT (1)		WLAN 2.4 GHz ANT (2)		(1)+(2) Σ SAR <sub>1g</sub> (W/Kg)	Event
				Band	SAR <sub>1g</sub> (W/Kg)	Band	SAR <sub>1g</sub> (W/Kg)		
Flat	Back	0	N/A	LTE Band	0.94	IEEE 802.11	0.14	1.08	<1.6
	Side 1	0	N/A	LTE Band	0.29	IEEE 802.11	0.4	0.69	<1.6
	Side 2	0	N/A	LTE Band	0.08	IEEE 802.11	0.4	0.48	<1.6
	Side 3	0	N/A	LTE Band	0.07	IEEE 802.11	0.21	0.28	<1.6
	Side 4	0	N/A	LTE Band	1.06	IEEE 802.11	0.14	1.20	<1.6

Phantom Position		Spacing (mm)	ASSY	WWAN ANT (1)		WLAN 5 GHz ANT (3)		(1)+(3) Σ SAR <sub>1g</sub> (W/Kg)	Event
				Band	SAR <sub>1g</sub> (W/Kg)	Band	SAR <sub>1g</sub> (W/Kg)		
Flat	Back	0	N/A	LTE Band	0.94	IEEE 802.11	0.21	1.15	<1.6
	Side 1	0	N/A	LTE Band	0.29	IEEE 802.11	**0.4	0.69	<1.6
	Side 2	0	N/A	LTE Band	0.08	IEEE 802.11	**0.4	0.48	<1.6
	Side 3	0	N/A	LTE Band	0.07	IEEE 802.11	*0.37	0.44	<1.6
	Side 4	0	N/A	LTE Band	1.06	IEEE 802.11	*0.25	1.31	<1.6

Phantom Position		Spacing (mm)	ASSY	WWAN ANT (1)		Bluetooth ANT (4)		(1)+(4) Σ SAR <sub>1g</sub> (W/Kg)	Event
				Band	SAR <sub>1g</sub> (W/Kg)	Band	SAR <sub>1g</sub> (W/Kg)		
Flat	Back	0	N/A	LTE Band	0.94	Bluetooth	0.06	1.00	<1.6
	Side 1	0	N/A	LTE Band	0.29	Bluetooth	**0.4	0.69	<1.6
	Side 2	0	N/A	LTE Band	0.08	Bluetooth	**0.4	0.48	<1.6
	Side 3	0	N/A	LTE Band	0.07	Bluetooth	*0.05	0.12	<1.6
	Side 4	0	N/A	LTE Band	1.06	Bluetooth	*0.03	1.09	<1.6



Phantom Position		Spacing (mm)	ASSY	WLAN 2.4 GHz ANT (2)		WLAN 5 GHz ANT (3)		(2)+(3)	Event
				Band	SAR <sub>1g</sub> (W/Kg)	Band	SAR <sub>1g</sub> (W/Kg)	∑ SAR <sub>1g</sub> (W/Kg)	
Flat	Back	0	N/A	IEEE 802.11	0.14	IEEE 802.11	0.21	0.35	<1.6
	Side 1	0	N/A	IEEE 802.11	**0.4	IEEE 802.11	**0.4	0.80	<1.6
	Side 2	0	N/A	IEEE 802.11	**0.4	IEEE 802.11	**0.4	0.80	<1.6
	Side 3	0	N/A	IEEE 802.11	*0.21	IEEE 802.11	*0.37	0.58	<1.6
	Side 4	0	N/A	IEEE 802.11	*0.14	IEEE 802.11	*0.25	0.39	<1.6

Phantom Position		Spacing (mm)	ASSY	WLAN 2.4 GHz ANT (2)		Bluetooth ANT (4)		(2)+(4)	Event
				Band	SAR <sub>1g</sub> (W/Kg)	Band	SAR <sub>1g</sub> (W/Kg)	∑ SAR <sub>1g</sub> (W/Kg)	
Flat	Back	0	N/A	IEEE 802.11	0.14	Bluetooth	0.06	0.20	<1.6
	Side 1	0	N/A	IEEE 802.11	**0.4	Bluetooth	**0.4	0.80	<1.6
	Side 2	0	N/A	IEEE 802.11	**0.4	Bluetooth	**0.4	0.80	<1.6
	Side 3	0	N/A	IEEE 802.11	*0.21	Bluetooth	*0.05	0.26	<1.6
	Side 4	0	N/A	IEEE 802.11	*0.14	Bluetooth	*0.03	0.17	<1.6

Phantom Position		Spacing (mm)	ASSY	WLAN 5 GHz ANT (3)		Bluetooth ANT (4)		(3)+(4)	Event
				Band	SAR <sub>1g</sub> (W/Kg)	Band	SAR <sub>1g</sub> (W/Kg)	∑ SAR <sub>1g</sub> (W/Kg)	
Flat	Back	0	N/A	IEEE 802.11	0.21	Bluetooth	0.06	0.27	<1.6
	Side 1	0	N/A	IEEE 802.11	**0.4	Bluetooth	**0.4	0.80	<1.6
	Side 2	0	N/A	IEEE 802.11	**0.4	Bluetooth	**0.4	0.80	<1.6
	Side 3	0	N/A	IEEE 802.11	*0.37	Bluetooth	*0.05	0.42	<1.6
	Side 4	0	N/A	IEEE 802.11	*0.25	Bluetooth	*0.03	0.28	<1.6

- Note: 1. \*=Estimated SAR.
2. \*\*The Estimated SAR 0.4 W/Kg, test separation distances is > 50 mm.
3. When the sum of 1-g SAR of all simultaneously transmitting antennas in and operating mode and exposure condition combination is within the SAR limit, SAR test exclusion applies to that simultaneous transmission configuration.



### 6.11.2 SAR to peak location separation ratio (SPLSR)

When the sum of SAR is larger than the limit, SAR test exclusion is determined by the SAR to peak location separation ratio. The ratio is determined by  $(SAR1 + SAR2)^{1.5}/R_i$ , rounded to two decimal digits, and must be  $\leq 0.04$  for all antenna pairs in the configuration to qualify for 1-g SAR test exclusion.

**All of sum of SAR < 1.6 W/kg, therefore SPLSR is not required.**

## 6.12 SAR test reduction according to KDB

General:

- The test data reported are the worst-case SAR value with the position set in a typical configuration. Test procedures used were according to FCC, Supplement C [June 2001], IEEE1528-2013.
- All modes of operation were investigated, and worst-case results are reported.
- Tissue parameters and temperatures are listed on the SAR plots.
- Batteries are fully charged for all readings.
- When the Channel's SAR 1 g of maximum conducted power is  $> 0.8$  mW/g, low, middle and high channel are supposed to be tested.

KDB 447498:

- The test data reported are the worst-case SAR value with the position set in a typical configuration. Test procedures used were according to IEEE1528-2013.

KDB 865664:

- Repeated measurement is not required when the original highest measured SAR is  $< 0.80$  W/kg.
- When the original highest measured SAR is  $\geq 0.80$  W/kg, repeat that measurement once.
- Perform a second repeated measurement only if the ratio of largest to smallest SAR for the original and first repeated measurements is  $> 1.20$  or when the original or repeated measurement is  $\geq 1.45$  W/kg.
- Perform a third repeated measurement only if the original, first or second repeated measurement is  $\geq 1.5$  W/kg and the ratio of largest to smallest SAR for the original, first and second repeated measurements is  $> 1.20$ .

KDB 941225:

- When HSDPA & (HSUPA / HSPA+ uplink with QPSK) power are not more than WCDMA 12.2K RMC 0.25 dB and the SAR value of WCDMA BII/BV  $< 1.2$  W/kg, therefore HSDPA & HSUPA / HSPA+ Stand-alone SAR is not required.
- SAR for EVDO Rev. A is not required when the maximum average output of each RF channels is less than that measured in Subtype 0/1 Physical layer configurations.
- For 1xRTT SAR is not required when the maximum average output of each channel is less than 1/4 dB higher than that measured in EVDO Rev.0.
- When the reported SAR is  $\leq 0.8$  W/kg, testing of the remaining RB offset configurations and required test channels is not required for 1 RB allocation, otherwise, SAR is required for the remaining required test channels and only for the RB offset configuration with the highest output power for that channel.
- For QPSK with 100 % RB allocation, SAR is not required when the highest maximum output power for 100 % RB allocation is less than the highest maximum output power in 50% and 1 RB allocations and the highest reported SAR for 1 RB and 50% RB allocation in 5.2.1 and 5.2.2 are  $\leq 0.8$  W/kg. Otherwise, SAR is measured for the highest output power channel and if the reported SAR is  $> 1.45$  W/kg, the remaining required test channels must also be tested.
- SAR is required only when the highest maximum output power for the configuration in the higher order modulation is  $> \frac{1}{2}$  dB higher than the same configuration in QPSK or when the reported SAR for the QPSK configuration is  $> 1.45$  W/kg.
- For smaller channel bandwidth SAR when the highest maximum output power of a configuration requiring testing in the smaller channel bandwidth is  $> \frac{1}{2}$  dB higher than the equivalent channel configurations in the largest channel bandwidth configuration or the reported SAR of a configuration for the largest channel bandwidth is  $> 1.45$  W/kg.

KDB 248227:

- Refer 6.7 SAR Testing with 802.11 Transmitters.

## 7. System Verification and Validation

### 7.1 Symmetric Dipoles for System Verification

Construction	Symmetrical dipole with 1/4 balun enables measurement of feed point impedance with NWA matched for use near flat phantoms filled with head simulating solutions Includes distance holder and tripod adaptor Calibration Calibrated SAR value for specified position and input power at the flat phantom in head simulating solutions.
Return Loss	> 20 dB at specified verification position
Options	Dipoles for other frequencies or solutions and other calibration conditions are available upon request

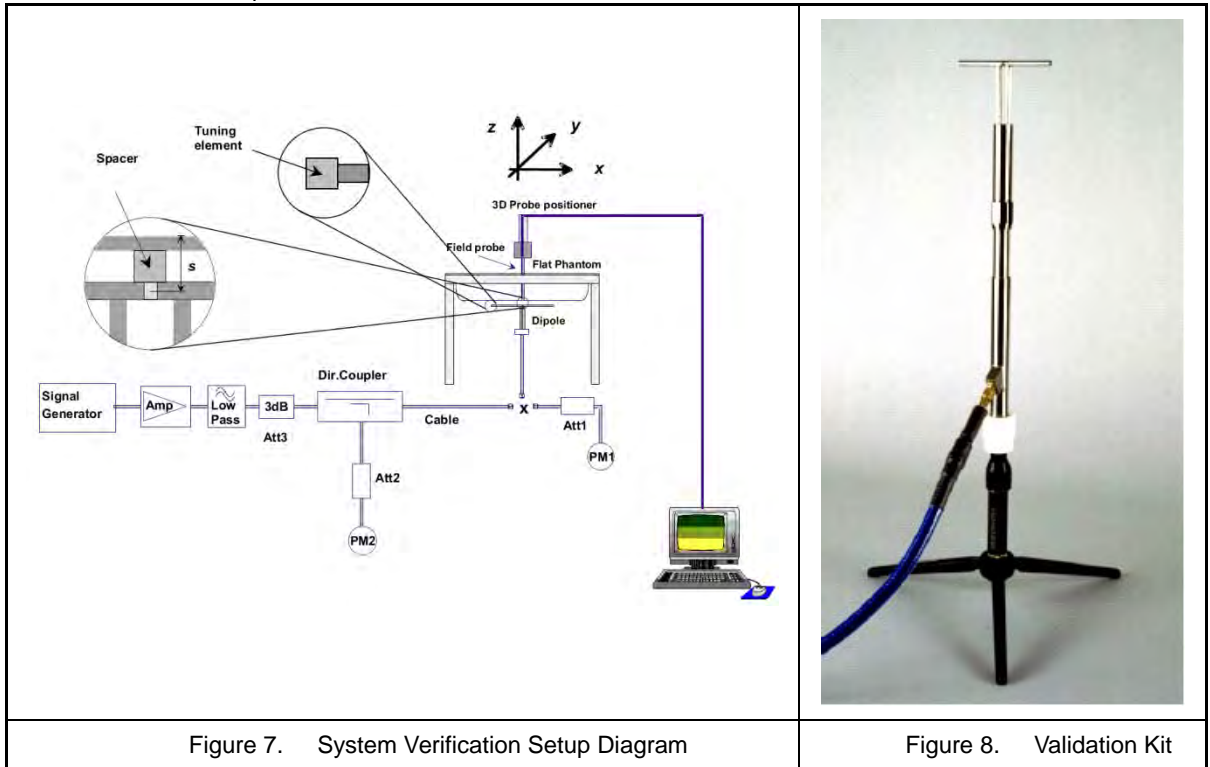

Figure 7. System Verification Setup Diagram



Figure 8. Validation Kit





## 7.2 Verification Summary

Prior to the assessment, the system validation kit was used to test whether the system was operating within its specifications of  $\pm 10\%$ . The measured SAR will be normalized to 1 W input power. The verification was performed at 750, 835, 1750, 1900, 2450, 5200, 5500 and 5800 MHz.

Mixture Type	Frequency (MHz)	Power	Probe Model / Serial No.	Dipole Model / Serial No.	SAR <sub>1g</sub> (W/Kg)	SAR <sub>10g</sub> (W/Kg)	1 W Target		Difference percentage		Date
							SAR <sub>1g</sub> [W/kg]	SAR <sub>10g</sub> [W/kg]	1 g	10 g	
Body	750	250 mW	EX3DV4-SN3578	D750V3-SN1004	2.38	1.61	8.80	5.97	7.6 %	7.3 %	May 08, 2019
		Normalize to 1 Watt			9.52	6.44					
Body	835	250 mW	EX3DV4-SN3578	D835V2-SN4d082	2.42	1.59	9.66	6.50	0.2 %	-2.2 %	May 08, 2019
		Normalize to 1 Watt			9.68	6.36					
Body	1750	250 mW	EX3DV4-SN3578	D1750V2-SN1023	9.39	4.85	36.80	19.70	2.0 %	-1.5 %	May 07, 2019
		Normalize to 1 Watt			37.56	19.40					
Body	1900	250 mW	EX3DV4-SN3578	D1900V2-SN5d111	10.5	5.42	40.40	21.80	3.8 %	-0.6 %	May 07, 2019
		Normalize to 1 Watt			42.00	21.68					
Body	2450	250 mW	EX3DV4-SN3578	D2450V2-SN735	13.2	5.8	50.20	23.70	4.9 %	-2.2 %	May 09, 2019
		Normalize to 1 Watt			52.80	23.20					
Body	5200	100 mW	EX3DV4-SN3578	D5200V2-SN1021	7.71	2.08	74.80	20.90	3.0 %	-0.5 %	May 09, 2019
		Normalize to 1 Watt			77.10	20.80					
Body	5500	100 mW	EX3DV4-SN3578	D5500V2-SN1021	8.49	2.3	81.50	22.60	4.0 %	1.7 %	May 09, 2019
		Normalize to 1 Watt			84.90	23.00					
Body	5800	100 mW	EX3DV4-SN3578	D5800V2-SN1021	8.46	2.26	77.70	21.60	8.2 %	4.4 %	May 09, 2019
		Normalize to 1 Watt			84.60	22.60					



## 8. Test Equipment List

Manufacturer	Name of Equipment	Type/Model	Serial Number	Calibration	
				Cal. Date	Cal.Period
SPEAG	750 MHz System Validation Kit	D750V3	1004	09/05/2018	1 year
SPEAG	835 MHz System Validation Kit	D835V2	4d082	09/06/2018	1 year
SPEAG	1800 MHz System Validation Kit	D1750V2	1023	06/11/2018	1 year
SPEAG	1900 MHz System Validation Kit	D1900V2	5d111	09/11/2018	1 year
SPEAG	2450 MHz System Validation Kit	D2450V2	735	12/11/2018	1 year
SPEAG	5 GHz System Validation Kit	D5GHzV2	1021	04/19/2019	1 year
SPEAG	Dosimetric E-Field Probe	EX3DV4	3578	05/29/2018	1 year
SPEAG	Data Acquisition Electronics	DAE4	541	03/19/2019	1 year
SPEAG	Measurement Server	SE UMS 011 AA	1025	NCR	
SPEAG	Device Holder	N/A	N/A	NCR	
SPEAG	Phantom	ELI V4.0	1036	NCR	
SPEAG	Robot	Staubli TX90XL	F16/54FTA1/A/01	NCR	
SPEAG	Software	DASY52 V52.10 (2)	N/A	NCR	
SPEAG	Software	SEMCAD X V14.6.12 (7450)	N/A	NCR	
R&S	Wireless Communication Test Set	CMU200	112387	12/03/2018	1 year
Anritsu	Radio Communication Analyzer	MT8820C	6201342039	12/13/2018	1 year
Agilent	ENA Series Network Analyzer	E5071B	MY42404655	04/17/2019	1 year
Agilent	Dielectric Probe Kit	85070C	US99360094	NCR	
HILA	Digital Thermometer	TM-906	GF-006	05/22/2018	1 year
Agilent	Power Sensor	8481H	3318A20779	06/12/2018	1 year
Agilent	Power Meter	EDM Series E4418B	GB40206143	06/12/2018	1 year
Agilent	Signal Generator	E8257D	MY44320425	03/05/2019	1 year
Agilent	Dual Directional Coupler	778D	50334	NCR	
Woken	Dual Directional Coupler	0100AZ20200801O	11012409517	NCR	
Mini-Circuits	Power Amplifier	EMC014225P	980292	NCR	
Mini-Circuits	Power Amplifier	EMC2830P	980293	NCR	
Aisi	Attenuator	IEAT 3dB	N/A	NCR	

Table 3. Test Equipment List



## 9. Measurement Uncertainty

Item	Uncertainty Component	Uncertainty Value	Prob. Dist	Div.	$c_i$ (1 g)	$c_i$ (10 g)	Std. Unc. (1-g)	Std. Unc. (10-g)	$v_i$ or $v_{eff}$
<b>Measurement System</b>									
u1	Probe Calibration ( $k=1$ )	±6.0 %	Normal	1	1	1	±6.0 %	±6.0 %	∞
u2	Axial Isotropy	±4.7 %	Rectangular	$\sqrt{3}$	0.7	0.7	±1.9 %	±1.9 %	∞
u3	Hemispherical Isotropy	±9.6 %	Rectangular	$\sqrt{3}$	0.7	0.7	±3.9 %	±3.9 %	
u4	Boundary Effect	±1.0 %	Rectangular	$\sqrt{3}$	1	1	±0.6 %	±0.6 %	∞
u5	Linearity	±4.7 %	Rectangular	$\sqrt{3}$	1	1	±2.7 %	±2.7 %	∞
u6	System Detection Limit	±1.0 %	Rectangular	$\sqrt{3}$	1	1	±0.6 %	±0.6 %	∞
u7	Readout Electronics	±0.3 %	Normal	1	1	1	±0.3 %	±0.3 %	∞
u8	Response Time	±0.8 %	Rectangular	$\sqrt{3}$	1	1	±0.5 %	±0.5 %	∞
u9	Integration Time	±1.9 %	Rectangular	$\sqrt{3}$	1	1	±1.1 %	±1.1 %	∞
u10	RF Ambient Conditions	±3.0 %	Rectangular	$\sqrt{3}$	1	1	±1.7 %	±1.7 %	∞
u11	RF Ambient Reflections	±3.0 %	Rectangular	$\sqrt{3}$	1	1	±1.7 %	±1.7 %	∞
u12	Probe Positioner Mechanical Tolerance	±0.4 %	Rectangular	$\sqrt{3}$	1	1	±0.2 %	±0.2 %	∞
u13	Probe Positioning with respect to Phantom Shell	±2.9 %	Rectangular	$\sqrt{3}$	1	1	±1.7 %	±1.7 %	∞
u14	Extrapolation, interpolation and integration Algorithms for Max. SAR Evaluation	±1.0 %	Rectangular	$\sqrt{3}$	1	1	±0.6 %	±0.6 %	∞
<b>Test sample Related</b>									
u15	Test sample Positioning	±2.9 %	Normal	1	1	1	±2.9 %	±2.9 %	89
u16	Device Holder Uncertainty	±3.6 %	Normal	1	1	1	±3.6 %	±3.6 %	5
u17	Output Power Variation - SAR drift measurement	±5.0 %	Rectangular	$\sqrt{3}$	1	1	±2.9 %	±2.9 %	∞
<b>Phantom and Tissue Parameters</b>									
u18	Phantom Uncertainty ( shape and thickness tolerances)	±4.0 %	Rectangular	$\sqrt{3}$	1	1	±2.3 %	±2.3 %	∞
u19	Liquid Conductivity - deviation from target values	±5.0 %	Rectangular	$\sqrt{3}$	0.64	0.43	±1.8 %	±1.2 %	∞
u20	Liquid Conductivity - measurement uncertainty	±2.5 %	Normal	1	0.64	0.43	±1.6 %	±1.08 %	69
u21	Liquid Permittivity - deviation from target values	±5.0 %	Rectangular	$\sqrt{3}$	0.6	0.49	±1.7 %	±1.4 %	∞
u22	Liquid Permittivity - measurement uncertainty	±2.5 %	Normal	1	0.6	0.49	±1.5 %	±1.23 %	69
Combined standard uncertainty			RSS				±10.94 %	±10.71 %	380
Expanded uncertainty (95 % CONFIDENCE LEVEL )			$k=2$				±21.88 %	±21.41 %	

Table 4. Uncertainty Budget for frequency range 300 MHz to 3 GHz



Item	Uncertainty Component	Uncertainty Value	Prob. Dist	Div.	$c_i$ (1 g)	$c_i$ (10 g)	Std. Unc. (1-g)	Std. Unc. (10-g)	$v_i$ or $V_{eff}$
Measurement System									
u1	Probe Calibration ( $k=1$ )	±6.5 %	Normal	1	1	1	±6.5 %	±6.5 %	∞
u2	Axial Isotropy	±4.7 %	Rectangular	$\sqrt{3}$	0.7	0.7	±1.9 %	±1.9 %	∞
u3	Hemispherical Isotropy	±9.6 %	Rectangular	$\sqrt{3}$	0.7	0.7	±3.9 %	±3.9 %	
u4	Boundary Effect	±2.0 %	Rectangular	$\sqrt{3}$	1	1	±1.2 %	±1.2 %	∞
u5	Linearity	±4.7 %	Rectangular	$\sqrt{3}$	1	1	±2.7 %	±2.7 %	∞
u6	System Detection Limit	±1.0 %	Rectangular	$\sqrt{3}$	1	1	±0.6 %	±0.6 %	∞
u7	Readout Electronics	±0.0 %	Normal	1	1	1	±0.0 %	±0.0 %	∞
u8	Response Time	±0.8 %	Rectangular	$\sqrt{3}$	1	1	±0.5 %	±0.5 %	∞
u9	Integration Time	±2.8 %	Rectangular	$\sqrt{3}$	1	1	±2.8 %	±2.8 %	∞
u10	RF Ambient Conditions	±3.0 %	Rectangular	$\sqrt{3}$	1	1	±1.7 %	±1.7 %	∞
u11	RF Ambient Reflections	±3.0 %	Rectangular	$\sqrt{3}$	1	1	±1.7 %	±1.7 %	∞
u12	Probe Positioner Mechanical Tolerance	±0.7 %	Rectangular	$\sqrt{3}$	1	1	±0.7 %	±0.7 %	∞
u13	Probe Positioning with respect to Phantom Shell	±9.9 %	Rectangular	$\sqrt{3}$	1	1	±5.7 %	±5.7 %	∞
u14	Extrapolation, interpolation and integration Algorithms for Max. SAR Evaluation	±3.0 %	Rectangular	$\sqrt{3}$	1	1	±1.7 %	±1.7 %	∞
Test sample Related									
u15	Test sample Positioning	±2.9 %	Normal	1	1	1	±2.9 %	±2.9 %	89
u16	Device Holder Uncertainty	±3.6 %	Normal	1	1	1	±3.6 %	±3.6 %	5
u17	Output Power Variation - SAR drift measurement	±5.0 %	Rectangular	$\sqrt{3}$	1	1	±2.9 %	±2.9 %	∞
Phantom and Tissue Parameters									
u18	Phantom Uncertainty ( shape and thickness tolerances)	±4.0 %	Rectangular	$\sqrt{3}$	1	1	±2.3 %	±2.3 %	∞
u19	Liquid Conductivity - deviation from target values	±5.0 %	Rectangular	$\sqrt{3}$	0.64	0.43	±1.8 %	±1.2 %	∞
u20	Liquid Conductivity - measurement uncertainty	±2.5 %	Normal	1	0.64	0.43	±1.6 %	±1.08 %	69
u21	Liquid Permittivity - deviation from target values	±5.0 %	Rectangular	$\sqrt{3}$	0.6	0.49	±1.7 %	±1.4 %	∞
u22	Liquid Permittivity - measurement uncertainty	±2.5 %	Normal	1	0.6	0.49	±1.5 %	±1.23 %	69
Combined standard uncertainty			RSS				±12.68 %	±12.48 %	700
Expanded uncertainty (95 % CONFIDENCE LEVEL )			$k=2$				±25.37 %	±24.97 %	

Table 5. Uncertainty Budget for frequency range 3 GHz to 6 GHz



## 10. Measurement Procedure

The measurement procedures are as follows:

1. For WLAN function, engineering testing software installed on DUTs can provide continuous transmitting signal.
2. Measure output power through RF cable and power meter
3. Set scan area, grid size and other setting on the DASY software
4. Find out the largest SAR result on these testing positions of each band
5. Measure SAR results for other channels in worst SAR testing position if the SAR of highest power channel is larger than 0.8 W/kg

According to the test standard, the recommended procedure for assessing the peak spatial-average SAR value consists of the following steps:

1. Power reference measurement
2. Area scan
3. Zoom scan
4. Power drift measurement

### 10.1 Spatial Peak SAR Evaluation

The procedure for spatial peak SAR evaluation has been implemented according to the test standard. It can be conducted for 1 g and 10 g, as well as for user-specific masses. The DASY software includes all numerical procedures necessary to evaluate the spatial peak SAR value.

The base for the evaluation is a "cube" measurement. The measured volume must include the 1 g and 10 g cubes with the highest averaged SAR values. For that purpose, the center of the measured volume is aligned to the interpolated peak SAR value of a previously performed area scan.

The entire evaluation of the spatial peak values is performed within the post-processing engine (SEMCAD). The system always gives the maximum values for the 1 g and 10 g cubes. The algorithm to find the cube with highest averaged SAR is divided into the following stages

1. Extraction of the measured data (grid and values) from the Zoom Scan
2. Calculation of the SAR value at every measurement point based on all stored data (A/D values and measurement parameters)
3. Generation of a high-resolution mesh within the measured volume
4. Interpolation of all measured values from the measurement grid to the high-resolution grid
5. Extrapolation of the entire 3-D field distribution to the phantom surface over the distance from sensor to surface
6. Calculation of the averaged SAR within masses of 1 g and 10 g



## 10.2 Area & Zoom Scan Procedures

First Area Scan is used to locate the approximate location(s) of the local peak SAR value(s). The measurement grid within an Area Scan is defined by the grid extent, grid step size and grid offset. Next, in order to determine the EM field distribution in a three-dimensional spatial extension, Zoom Scan is required. The Zoom Scan measures points and step size follow as below. The Zoom Scan is performed around the highest E-field value to determine the averaged SAR-distribution over 10 g.

Grid Type	Frequency		Step size (mm)			X*Y*Z (Point)	Cube size			Step size		
			X	Y	Z		X	Y	Z	X	Y	Z
uniform grid	≤ 3 GHz	≤ 2 GHz	≤ 8	≤ 8	≤ 5	5*5*7	32	32	30	8	8	5
		2 G - 3 G	≤ 5	≤ 5	≤ 5	7*7*7	30	30	30	5	5	5
	3 - 6 GHz	3 - 4 GHz	≤ 5	≤ 5	≤ 4	7*7*8	30	30	28	5	5	4
		4 - 5 GHz	≤ 4	≤ 4	≤ 3	8*8*10	28	28	27	4	4	3
		5 - 6 GHz	≤ 4	≤ 4	≤ 2	8*8*12	28	28	22	4	4	2

(Our measure settings are refer KDB Publication 865664 D01v01r04)

## 10.3 Volume Scan Procedures

The volume scan is used for assess overlapping SAR distributions for antennas transmitting in different frequency bands. It is equivalent to an oversized zoom scan used in standalone measurements. The measurement volume will be used to enclose all the simultaneous transmitting antennas. For antennas transmitting simultaneously in different frequency bands, the volume scan is measured separately in each frequency band. In order to sum correctly to compute the 1 g aggregate SAR, the DUT remain in the same test position for all measurements and all volume scan use the same spatial resolution and grid spacing. When all volume scan were completed, the software, SEMCAD postprocessor can combine and subsequently superpose these measurement data to calculating the multiband SAR.

## 10.4 SAR Averaged Methods

In DASYS, the interpolation and extrapolation are both based on the modified Quadratic Shepard's method. The interpolation scheme combines a least-square fitted function method and a weighted average method which are the two basic types of computational interpolation and approximation. Extrapolation routines are used to obtain SAR values between the lowest measurement points and the inner phantom surface. The extrapolation distance is determined by the surface detection distance and the probe sensor offset. The uncertainty increases with the extrapolation distance. To keep the uncertainty within 1% for the 1 g and 10 g cubes, the extrapolation distance should not be larger than 5 mm.

## 10.5 Power Drift Monitoring

All SAR testing is under the DUT install full charged battery and transmit maximum output power. In DASYS measurement software, the power reference measurement and power drift measurement procedures are used for monitoring the power drift of DUT during SAR test. Both these procedures measure the field at a specified reference position before and after the SAR testing. The software will calculate the field difference in dB. If the power drift more than 5 %, the SAR will be retested.



## 11. SAR Test Results Summary

1. Based on the IEEE1528 and IEC 62209 requirements, the low, mid and high frequency channels for the configuration with the highest SAR value must be tested regardless of the SAR value measured.
2. Start with the largest channel bandwidth and measure SAR for QPSK with 1 RB allocation, using the RB offset and required test channel combination with the highest maximum output power for RB offsets at the upper edge, middle and lower edge of each required test channel.
3. When the highest reported SAR for 1 RB and 50 % RB allocation are  $> 0.8$  W/kg, SAR is measured for the highest output power channel in 100 % RB.
4. The procedures required for 1 RB allocation are applied to measure the SAR for QPSK with 50 % RB allocation.
5. When a device supports overlapping channel assignment in a channel bandwidth configuration, the middle channel of the group of overlapping channels should be selected for testing; therefore, the requirement for H, M, and L channels may not fully apply.
6. When the maximum output power and tune-up tolerance specified for production units in a secondary mode is  $\leq \frac{1}{4}$  dB higher than the primary mode or when the highest reported SAR of the primary mode is scaled by the ratio of specified maximum output power and tune-up tolerance of secondary to primary mode and the adjusted SAR is  $\leq 1.2$  W/kg, SAR measurement is not required for the secondary mode.
7. The 3G SAR test reduction procedure is applied to HSPA (HSUPA/HSDPA with RMC) configurations with 12.2 kbps RMC as the primary mode.
8. When the reported SAR of the highest measured maximum output power channel is  $\leq 0.8$  W/kg, no further SAR testing is required for 802.11b DSSS.
9. The initial test configuration for OFDM transmission modes is determined by the 802.11 configuration with the highest maximum output power specified for production units, including tune-up tolerance, in each standalone and aggregated frequency band.
10. SAR for the initial test configuration is measured using the highest maximum output power channel.
11. When different maximum output power is specified for the band1&band2A, begin SAR measurement in the band with higher specified maximum output power. The highest reported SAR for the tested configuration is adjusted by the ratio of lower to higher specified maximum output power for the two bands. When the adjusted SAR is  $\leq 1.2$  W/kg, SAR is not required for the band with lower maximum output power in that test configuration; otherwise, each band is tested independently for SAR.
12. When the highest reported SAR for the initial test configuration, according to the initial test position or fixed exposure position requirements, is adjusted by the ratio of the subsequent test configuration to initial test configuration specified maximum output power and the adjusted SAR is  $\leq 1.2$  W/kg, SAR is not required for that subsequent test configuration.
13. Model MLP9073102 is the battery 2 which using in test mode.



## 11.1 Body SAR Measurement

Index.	Band	Frequency		Modulation or Sub-Test	Test Position	Spacing (mm)	EUT & Accessory	SAR <sub>1g</sub> (W/kg)	Burst Avg Power	Max tune-up	Duty Cycle (%)	Reported SAR <sub>1g</sub> (W/kg)
		Ch.	MHz									
#1	WCDMA Band II	9400	1880.0	RMC12.2K	Back	0	---	0.707	20.49	20.5	100	0.71
#2	WCDMA Band II	9400	1880.0	RMC12.2K	Side 1	0	---	0.210	20.49	20.5	100	0.21
#3	WCDMA Band II	9400	1880.0	RMC12.2K	Side 4	0	---	0.906	20.49	20.5	100	<b>0.91</b>
#6	WCDMA Band II	9400	1880.0	RMC12.2K	Side 4	0	Battery 2	0.879	20.49	20.5	100	0.88
#4	WCDMA Band II	9262	1852.4	RMC12.2K	Side 4	0	---	0.830	20.37	20.5	100	0.86
#5	WCDMA Band II	9538	1907.6	RMC12.2K	Side 4	0	---	0.814	20.46	20.5	100	0.82
#33	WCDMA Band V	4233	846.6	RMC12.2K	Back	0	---	0.489	23.48	24.0	100	0.55
#34	WCDMA Band V	4132	826.4	RMC12.2K	Back	0	---	0.477	23.32	24.0	100	<b>0.56</b>
#40	WCDMA Band V	4132	826.4	RMC12.2K	Back	0	Battery 2	0.463	23.32	24.0	100	0.54
#35	WCDMA Band V	4183	836.6	RMC12.2K	Back	0	---	0.480	23.44	24.0	100	0.55
#36	WCDMA Band V	4233	846.6	RMC12.2K	Side 1	0	---	0.244	23.48	24.0	100	0.28
#37	WCDMA Band V	4233	846.6	RMC12.2K	Side 2	0	---	0.053	23.48	24.0	100	0.06
#38	WCDMA Band V	4233	846.6	RMC12.2K	Side 3	0	---	0.036	23.48	24.0	100	0.04
#39	WCDMA Band V	4233	846.6	RMC12.2K	Side 4	0	---	0.297	23.48	24.0	100	0.34





Index.	Band	Frequency		Bandwidth	RB Size	RB Offset	Test Position	Spacing (mm)	EUT & Accessory	SAR <sub>1g</sub> (W/kg)	Burst Avg Power	Max tune-up	Duty Cycle (%)	Reported SAR <sub>1g</sub> (W/kg)
		Ch.	MHz											
#7	LTE Band 2 (QPSK)	19100	1900.0	20 MHz	1	0	Back	0	---	0.748	20.85	21.0	100	0.77
#13	LTE Band 2 (QPSK)	18700	1860.0	20 MHz	1	0	Back	0	---	0.807	20.83	21.0	100	0.84
#14	LTE Band 2 (QPSK)	18900	1880.0	20 MHz	1	0	Back	0	---	0.832	20.81	21.0	100	0.87
#8	LTE Band 2 (QPSK)	19100	1900.0	20 MHz	50	0	Back	0	---	0.616	19.83	20.0	100	0.64
#15	LTE Band 2 (QPSK)	18900	1880.0	20 MHz	100	0	Back	0	---	0.582	19.80	20.0	100	0.61
#9	LTE Band 2 (QPSK)	19100	1900.0	20 MHz	1	0	Side 1	0	---	0.239	20.85	21.0	100	0.25
#10	LTE Band 2 (QPSK)	19100	1900.0	20 MHz	50	0	Side 1	0	---	0.193	19.83	20.0	100	0.20
#11	LTE Band 2 (QPSK)	19100	1900.0	20 MHz	1	0	Side 4	0	---	1.000	20.85	21.0	100	1.04
#16	LTE Band 2 (QPSK)	18700	1860.0	20 MHz	1	0	Side 4	0	---	0.914	20.83	21.0	100	0.95
#17	LTE Band 2 (QPSK)	18900	1880.0	20 MHz	1	0	Side 4	0	---	1.010	20.81	21.0	100	<b>1.06</b>
#21	LTE Band 2 (QPSK)	18900	1880.0	20 MHz	1	0	Side 4	0	Battery 2	0.985	20.81	21.0	100	1.03
#12	LTE Band 2 (QPSK)	19100	1900.0	20 MHz	50	0	Side 4	0	---	0.776	19.83	20.0	100	0.81
#18	LTE Band 2 (QPSK)	18700	1860.0	20 MHz	50	0	Side 4	0	---	0.729	19.71	20.0	100	0.78
#19	LTE Band 2 (QPSK)	18900	1880.0	20 MHz	50	50	Side 4	0	---	0.769	19.76	20.0	100	0.81
#20	LTE Band 2 (QPSK)	18900	1880.0	20 MHz	100	0	Side 4	0	---	0.784	19.80	20.0	100	0.82
#23	LTE Band 4 (QPSK)	20175	1732.5	20 MHz	1	0	Back	0	---	0.754	23.56	24.5	100	<b>0.94</b>
#24	LTE Band 4 (QPSK)	20175	1732.5	20 MHz	50	0	Back	0	---	0.629	22.37	23.5	100	0.82
#25	LTE Band 4 (QPSK)	20175	1732.5	20 MHz	100	0	Back	0	---	0.631	22.16	23.5	100	0.86
#26	LTE Band 4 (QPSK)	20175	1732.5	20 MHz	1	0	Side 1	0	---	0.235	23.56	24.5	100	0.29
#27	LTE Band 4 (QPSK)	20175	1732.5	20 MHz	50	0	Side 1	0	---	0.180	22.37	23.5	100	0.23
#28	LTE Band 4 (QPSK)	20175	1732.5	20 MHz	1	0	Side 4	0	---	0.755	23.56	24.5	100	0.94
#31	LTE Band 4 (QPSK)	20175	1732.5	20 MHz	1	0	Side 4	0	Battery 2	0.734	23.56	24.5	100	0.91
#29	LTE Band 4 (QPSK)	20175	1732.5	20 MHz	50	0	Side 4	0	---	0.615	22.37	23.5	100	0.80
#30	LTE Band 4 (QPSK)	20175	1732.5	20 MHz	100	0	Side 4	0	---	0.624	22.16	23.5	100	0.85



Index.	Band	Frequency		Bandwidth	RB Size	RB Offset	Test Position	Spacing (mm)	EUT & Accessory	SAR <sub>1g</sub> (W/kg)	Burst Avg Power	Max tune-up	Duty Cycle (%)	Reported SAR <sub>1g</sub> (W/kg)
		Ch.	MHz											
#42	LTE Band 5 (QPSK)	20525	836.5	10 MHz	1	0	Back	0	---	0.440	23.24	24.5	100	<b>0.59</b>
#52	LTE Band 5 (QPSK)	20525	836.5	10 MHz	1	0	Back	0	Battery 2	0.428	23.24	24.5	100	0.57
#43	LTE Band 5 (QPSK)	20525	836.5	10 MHz	25	0	Back	0	---	0.360	22.13	23.5	100	0.49
#44	LTE Band 5 (QPSK)	20525	836.5	10 MHz	1	0	Side 1	0	---	0.200	23.24	24.5	100	0.27
#45	LTE Band 5 (QPSK)	20525	836.5	10 MHz	25	0	Side 1	0	---	0.161	22.13	23.5	100	0.22
#46	LTE Band 5 (QPSK)	20525	836.5	10 MHz	1	0	Side 2	0	---	0.060	23.24	24.5	100	0.08
#47	LTE Band 5 (QPSK)	20525	836.5	10 MHz	25	0	Side 2	0	---	0.048	22.13	23.5	100	0.07
#48	LTE Band 5 (QPSK)	20525	836.5	10 MHz	1	0	Side 3	0	---	0.031	23.24	24.5	100	0.04
#49	LTE Band 5 (QPSK)	20525	836.5	10 MHz	25	0	Side 3	0	---	0.026	22.13	23.5	100	0.04
#50	LTE Band 5 (QPSK)	20525	836.5	10 MHz	1	0	Side 4	0	---	0.237	23.24	24.5	100	0.32
#51	LTE Band 5 (QPSK)	20525	836.5	10 MHz	25	0	Side 4	0	---	0.189	22.13	23.5	100	0.26
#54	LTE Band 12 (QPSK)	23095	707.5	10 MHz	1	24	Back	0	---	0.458	23.25	24.0	100	<b>0.54</b>
#64	LTE Band 12 (QPSK)	23095	707.5	10 MHz	1	24	Back	0	Battery 2	0.441	23.25	24.0	100	0.52
#55	LTE Band 12 (QPSK)	23095	707.5	10 MHz	25	0	Back	0	---	0.362	22.00	23.0	100	0.46
#56	LTE Band 12 (QPSK)	23095	707.5	10 MHz	1	24	Side 1	0	---	0.126	23.25	24.0	100	0.15
#57	LTE Band 12 (QPSK)	23095	707.5	10 MHz	25	0	Side 1	0	---	0.102	22.00	23.0	100	0.13
#58	LTE Band 12 (QPSK)	23095	707.5	10 MHz	1	24	Side 2	0	---	0.047	23.25	24.0	100	0.06
#59	LTE Band 12 (QPSK)	23095	707.5	10 MHz	25	0	Side 2	0	---	0.034	22.00	23.0	100	0.04
#60	LTE Band 12 (QPSK)	23095	707.5	10 MHz	1	24	Side 3	0	---	0.060	23.25	24.0	100	0.07
#61	LTE Band 12 (QPSK)	23095	707.5	10 MHz	25	0	Side 3	0	---	0.047	22.00	23.0	100	0.06
#62	LTE Band 12 (QPSK)	23095	707.5	10 MHz	1	24	Side 4	0	---	0.295	23.25	24.0	100	0.35
#63	LTE Band 12 (QPSK)	23095	707.5	10 MHz	25	0	Side 4	0	---	0.251	22.00	23.0	100	0.32



Index.	Band	Mode	Frequency		Data Rate	Test Position	Spacing (mm)	EUT & Accessory	SAR <sub>1g</sub> (W/kg)	Burst Avg Power	Max tune-up	Duty Cycle %	Reported SAR <sub>1g</sub> (W/kg)
			Ch.	MHz									
#66	WLAN 2.4 GHz	802.11b	6	2437.0	1 Mbps	Back	0	---	0.105	12.50	13.5	97.6	0.14
#67	WLAN 2.4 GHz	802.11b	1	2412.0	1 Mbps	Back	0	---	0.084	12.10	13.5	97.6	0.12
#69	WLAN 2.4 GHz	802.11b	1	2412.0	1 Mbps	Back	0	Battery 2	0.081	12.10	13.5	97.6	0.12
#68	WLAN 2.4 GHz	802.11b	11	2462.0	1 Mbps	Back	0	---	0.074	13.03	13.5	97.6	0.09
#72	Bluetooth	---	0	2402.0	1 Mbps	Back	0	---	0.031	5.14	7.0	76.5	0.05
#73	Bluetooth	---	39	2441.0	1 Mbps	Back	0	---	0.033	5.08	7.0	76.5	0.06
#74	Bluetooth	---	78	2480.0	1 Mbps	Back	0	---	0.034	5.55	7.0	76.5	0.05
#75	Bluetooth	---	78	2480.0	1 Mbps	Back	0	Battery 2	0.033	5.55	7.0	76.5	0.05
#77	WLAN 5 GHz	802.11n 20 MHz	60	5300.0	6.5 Mbps	Back	0	---	0.106	13.51	14.0	84.3	0.14
#78	WLAN 5 GHz	802.11n 20 MHz	52	5260.0	6.5 Mbps	Back	0	---	0.083	13.74	14.0	84.3	0.11
#79	WLAN 5 GHz	802.11n 20 MHz	56	5280.0	6.5 Mbps	Back	0	---	0.090	13.35	14.0	84.3	0.12
#80	WLAN 5 GHz	802.11n 20 MHz	64	5320.0	6.5 Mbps	Back	0	---	0.104	13.26	14.0	84.3	0.15
#81	WLAN 5 GHz	802.11n 20 MHz	64	5320.0	6.5 Mbps	Back	0	Battery 2	0.100	13.26	14.0	84.3	0.14
#83	WLAN 5 GHz	802.11n 20 MHz	116	5580.0	6.5 Mbps	Back	0	---	0.120	12.47	13.5	84.3	0.18
#84	WLAN 5 GHz	802.11n 20 MHz	100	5500.0	6.5 Mbps	Back	0	---	0.109	12.26	13.5	84.3	0.17
#86	WLAN 5 GHz	802.11n 20 MHz	132	5660.0	6.5 Mbps	Back	0	---	0.135	12.50	13.5	84.3	0.20
#88	WLAN 5 GHz	802.11n 20 MHz	132	5660.0	6.5 Mbps	Back	0	Battery 2	0.130	12.50	13.5	84.3	0.19
#87	WLAN 5 GHz	802.11n 20 MHz	140	5700.0	6.5 Mbps	Back	0	---	0.129	13.06	13.5	84.3	0.17
#90	WLAN 5 GHz	802.11a	165	5825.0	6 Mbps	Back	0	---	0.145	11.42	12.5	89.8	0.21
#93	WLAN 5 GHz	802.11a	165	5825.0	6 Mbps	Back	0	Battery 2	0.144	11.42	12.5	89.8	0.21
#91	WLAN 5 GHz	802.11a	149	5745.0	6 Mbps	Back	0	---	0.119	11.77	12.5	89.8	0.16
#92	WLAN 5 GHz	802.11a	157	5785.0	6 Mbps	Back	0	---	0.128	11.39	12.5	89.8	0.18



## 11.2 SAR Variability Measurement

Detailed evaluations please refer KDB 865664 on "SAR test reduction according to KDB" section.

SAR measurement variability must be assessed for each frequency band, which is determined by the SAR probe calibration point and tissue-equivalent medium used for the device measurements. When both head and body tissue-equivalent media are required for SAR measurements in a frequency band, the variability measurement procedures should be applied to the tissue medium with the highest measured SAR, using the highest measured SAR configuration for that tissue-equivalent medium.

The following procedures are applied to determine if repeated measurements are required.

1. The original highest measured Reported SAR  $1g$  is  $\geq 0.80$  W/kg, repeat that measurement once.
2. Perform a second repeated measurement the ratio of largest to smallest SAR for the original and first repeated measurements is  $< 1.2$ , the original or repeated measurement is  $\geq 1.45$  W/kg ( $\sim 10\%$  from the 1-g SAR limit).
3. Perform a third repeated measurement only if the original, first or second repeated measurement is  $\geq 1.5$  W/kg and the ratio of largest to smallest SAR for the original, first and second repeated measurements is  $> 1.20$ .

Index.	Band	Frequency		Bandwidth	RB Size	RB Offset	Test Position	Spacing (mm)	EUT & Accessory	Note	Original SAR <sub>1g</sub> (W/Kg)	First SAR <sub>1g</sub> (W/Kg)	Ratio
		Ch.	MHz										
#22	LTE Band 2 (QPSK)	18900	1880.0	20 MHz	1	0	Side 4	0	---	original #17	1.010	1.000	1.01



### 11.3 Std. C95.1-1992 RF Exposure Limit

Human Exposure	Population Uncontrolled Exposure ( W/kg ) or (mW/g)	Occupational Controlled Exposure ( W/kg ) or (mW/g)
Spatial Peak SAR* (head)	1.60	8.00
Spatial Peak SAR** (Whole Body)	0.08	0.40
Spatial Peak SAR*** (Partial-Body)	1.60	8.00
Spatial Peak SAR**** (Hands / Feet / Ankle / Wrist )	4.00	20.00

Table 6. Safety Limits for Partial Body Exposure

**Notes :**

- \* The Spatial Peak value of the SAR averaged over any 1 gram of tissue. ( defined as a tissue volume in the shape of a cube ) and over the appropriate averaging time.
- \*\* The Spatial Average value of the SAR averaged over the whole – body.
- \*\*\* The Spatial Average value of the SAR averaged over the partial – body.
- \*\*\*\* The Spatial Peak value of the SAR averaged over any 10 grams of tissue. ( defined as a tissue volume in the shape of a cube ) and over the appropriate averaging time.

**Population / Uncontrolled Environments :** are defined as locations where there is the exposure of individuals who have no knowledge or control of their exposure.

**Occupational / Controlled Environments :** are defined as locations where there is exposure that may be incurred by persons who are aware of the potential for exposure, (i.e. as a result of employment or occupation).



## 12. References

- [1] Std. C95.1-1999, "American National Standard safety levels with respect to human exposure to radio frequency electromagnetic fields, 300KHz to 100GHz", New York.
- [2] NCRP, National Council on Radiation Protection and Measurements, "Biological Effects and Exposure Criteria for Radio frequency Electromagnetic Fields", NCRP report NO. 86, 1986.
- [3] T. Schmid, O. Egger, and N. Kuster, "Automatic E-field scanning system for dosimetric assessments", IEEE Transactions on Microwave Theory and Techniques, vol. 44, pp, 105-113, Jan. 1996.
- [4] K. Pokovi<sup>c</sup>, T. Schmid, and N. Kuster, "Robust setup for precise calibration of E-field probes in tissue simulating liquids at mobile communications frequency", in ICECOM'97, Dubrovnik, October 15-17, 1997, pp.120-124.
- [5] K. Pokovi<sup>c</sup>, T. Schmid, and N. Kuster, "E-field probe with improved isotropy in brain simulating liquids", in Proceedings of the ELMAR, Zadar, Croatia, 23-25 June, 1996, pp.172-175.
- [6] N. Kuster, and Q. Balzano, "Energy absorption mechanism by biological bodies in the near field of dipole antennas above 300MHz", IEEE Transaction on Vehicular Technology, vol. 41, no. 1, Feb. 1992, pp. 17-23.
- [7] Robert J. Renka, "Multivariate Interpolation Of Large Sets Of Scattered Data", University of North Texas ACM Transactions on Mathematical Software, vol. 14, no. 2, June 1988 , pp. 139-148.
- [8] N. Kuster, R. Kastle, T. Schmid, Dosimetric evaluation of mobile communications equipment with known precision, IEEE Transaction on Communications, vol. E80-B, no. 5, May 1997, pp. 645-652.
- [9] Std. C95.3-1991, "IEEE Recommended Practice for the Measurement of Potentially Hazardous Electromagnetic Fields – RF and Microwave, New York: IEEE, Aug. 1992.
- [10] CENELEC CLC/SC111B, European Prestandard (prENV 50166-2), Human Exposure to Electromagnetic Fields High-frequency: 10KHz-300GHz, Jan. 1995.
- [11] IEEE Std 1528™-2013 - IEEE Recommended Practice for Determining the Peak Spatial-Average Specific Absorption Rate (SAR) in the Human Head From Wireless Communications Devices: Measurement Techniques

## Appendix A - System Performance Check

Test Laboratory: A Test Lab Techno Corp.

Date/Time: 2019/5/8

### System Performance Check at 750MHz\_20190508\_Body

**DUT: Dipole 750 MHz; Type: D750V3; Serial: D750V3 - SN:1004**

Communication System: UID 0, CW (0); Frequency: 750 MHz; Duty Cycle: 1:1

Medium parameters used:  $f = 750 \text{ MHz}$ ;  $\sigma = 0.969 \text{ S/m}$ ;  $\epsilon_r = 56.569$ ;  $\rho = 1000 \text{ kg/m}^3$

Phantom section: Flat Section

Measurement Standard: DASYS (IEEE/IEC/ANSI C63.19-2007)

DASY5.2 Configuration:

- Area Scan setting - Find Secondary Maximum Within: 2.0dB and with a peak SAR value greater than 0.5 W/Kg
- Probe: EX3DV4 - SN3578; ConvF(9.89, 9.89, 9.89); Calibrated: 2018/5/29
- Sensor-Surface: 1.4mm (Mechanical Surface Detection)
- Electronics: DAE4 Sn541; Calibrated: 2019/3/19
- Phantom: ELI v4.0; Type: QDOVA001BB; Serial: TP:1036
- Measurement SW: DASYS2, Version 52.10 (2); SEMCAD X Version 14.6.12 (7450)

**System Performance Check at 750MHz/Area Scan (61x121x1):** Interpolated grid:  $dx=1.500 \text{ mm}$ ,  $dy=1.500 \text{ mm}$

Maximum value of SAR (interpolated) = 3.18 W/kg

**System Performance Check at 750MHz/Zoom Scan (5x5x7)/Cube 0:** Measurement grid:  $dx=8\text{mm}$ ,  $dy=8\text{mm}$ ,  $dz=5\text{mm}$

Reference Value = 59.16 V/m; Power Drift = -0.03 dB

Peak SAR (extrapolated) = 3.60 W/kg

**SAR(1 g) = 2.38 W/kg; SAR(10 g) = 1.61 W/kg**

Maximum value of SAR (measured) = 3.16 W/kg

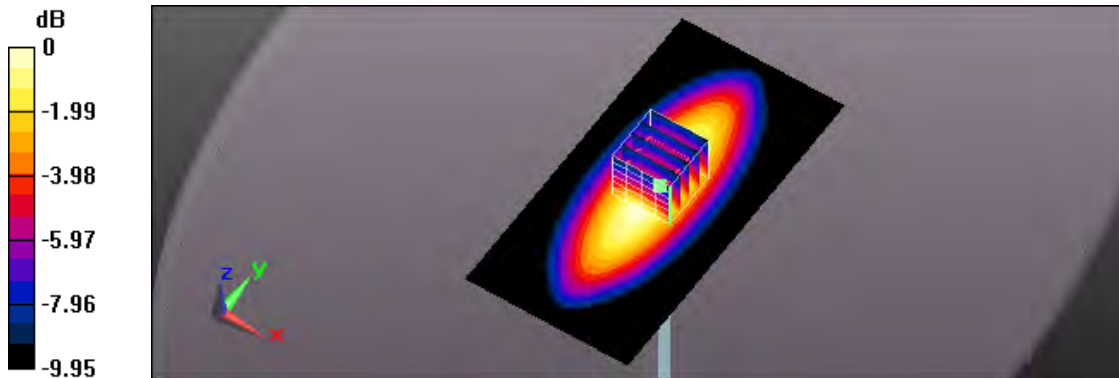

0 dB = 3.16 W/kg = 5.00 dBW/kg

Test Laboratory: A Test Lab Techno Corp.

Date/Time: 2019/5/8

**System Performance Check at 835MHz\_20190508\_Body**

**DUT: Dipole 835 MHz; Type: D835V2; Serial: D835V2 - SN:4d082**

Communication System: UID 0, CW (0); Frequency: 835 MHz; Duty Cycle: 1:1

Medium parameters used:  $f = 835 \text{ MHz}$ ;  $\sigma = 0.999 \text{ S/m}$ ;  $\epsilon_r = 56.912$ ;  $\rho = 1000 \text{ kg/m}^3$

Phantom section: Flat Section

Measurement Standard: DASYS (IEEE/IEC/ANSI C63.19-2007)

DASY5.2 Configuration:

- Area Scan setting - Find Secondary Maximum Within:2.0dB and with a peak SAR value greater than 0.5 W/Kg
- Probe: EX3DV4 - SN3578; ConvF(9.49, 9.49, 9.49); Calibrated: 2018/5/29
- Sensor-Surface: 1.4mm (Mechanical Surface Detection)
- Electronics: DAE4 Sn541; Calibrated: 2019/3/19
- Phantom: ELI v4.0; Type: QDOVA001BB; Serial: TP:1036
- Measurement SW: DASYS2, Version 52.10 (2); SEMCAD X Version 14.6.12 (7450)

**System Performance Check at 835MHz/Area Scan (61x121x1):** Interpolated grid:  $dx=1.500 \text{ mm}$ ,  $dy=1.500 \text{ mm}$

Maximum value of SAR (interpolated) = 3.27 W/kg

**System Performance Check at 835MHz/Zoom Scan (5x5x7)/Cube 0:** Measurement grid:  $dx=8\text{mm}$ ,  $dy=8\text{mm}$ ,  $dz=5\text{mm}$

Reference Value = 59.13 V/m; Power Drift = -0.01 dB

Peak SAR (extrapolated) = 3.72 W/kg

**SAR(1 g) = 2.42 W/kg; SAR(10 g) = 1.59 W/kg**

Maximum value of SAR (measured) = 3.27 W/kg

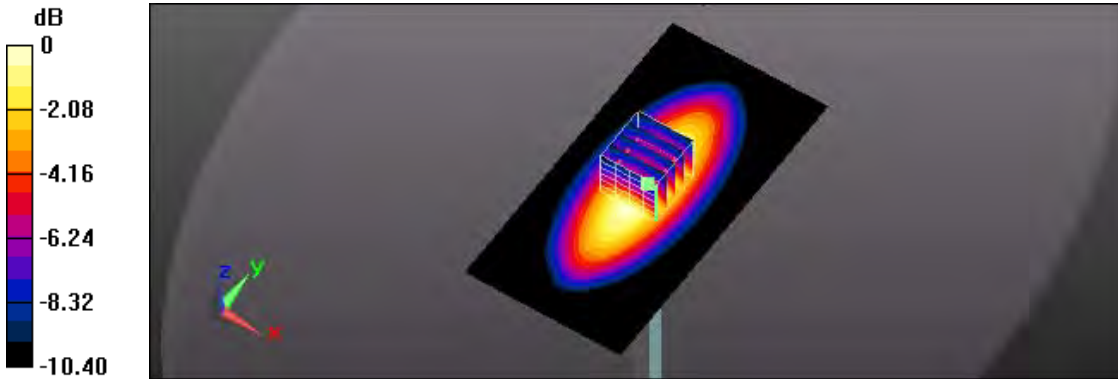

0 dB = 3.27 W/kg = 5.15 dBW/kg



Test Laboratory: A Test Lab Techno Corp.

Date/Time: 2019/5/7

**System Performance Check at 1750MHz\_20190507\_Body**

**DUT: Dipole 1750 MHz; Type: D1750V2; Serial: D1750V2 - SN:1023**

Communication System: UID 0, CW (0); Frequency: 1750 MHz; Duty Cycle: 1:1

Medium parameters used:  $f = 1750 \text{ MHz}$ ;  $\sigma = 1.457 \text{ S/m}$ ;  $\epsilon_r = 53.164$ ;  $\rho = 1000 \text{ kg/m}^3$

Phantom section: Flat Section

Measurement Standard: DASY5 (IEEE/IEC/ANSI C63.19-2007)

DASY5.2 Configuration:

- Area Scan setting - Find Secondary Maximum Within: 2.0dB and with a peak SAR value greater than 0.5 W/Kg
- Probe: EX3DV4 - SN3578; ConvF(7.92, 7.92, 7.92); Calibrated: 2018/5/29
- Sensor-Surface: 1.4mm (Mechanical Surface Detection)
- Electronics: DAE4 Sn541; Calibrated: 2019/3/19
- Phantom: ELI v4.0; Type: QDOVA001BB; Serial: TP:1036
- Measurement SW: DASY52, Version 52.10 (2); SEMCAD X Version 14.6.12 (7450)

**System Performance Check at 1750MHz/Area Scan (61x61x1):** Interpolated grid:  $dx=1.500 \text{ mm}$ ,  $dy=1.500 \text{ mm}$

Maximum value of SAR (interpolated) = 14.9 W/kg

**System Performance Check at 1750MHz/Zoom Scan (5x5x7)/Cube 0:** Measurement grid:  $dx=8\text{mm}$ ,  $dy=8\text{mm}$ ,  $dz=5\text{mm}$

Reference Value = 103.8 V/m; Power Drift = -0.01 dB

Peak SAR (extrapolated) = 17.8 W/kg

**SAR(1 g) = 9.39 W/kg; SAR(10 g) = 4.85 W/kg**

Maximum value of SAR (measured) = 14.8 W/kg

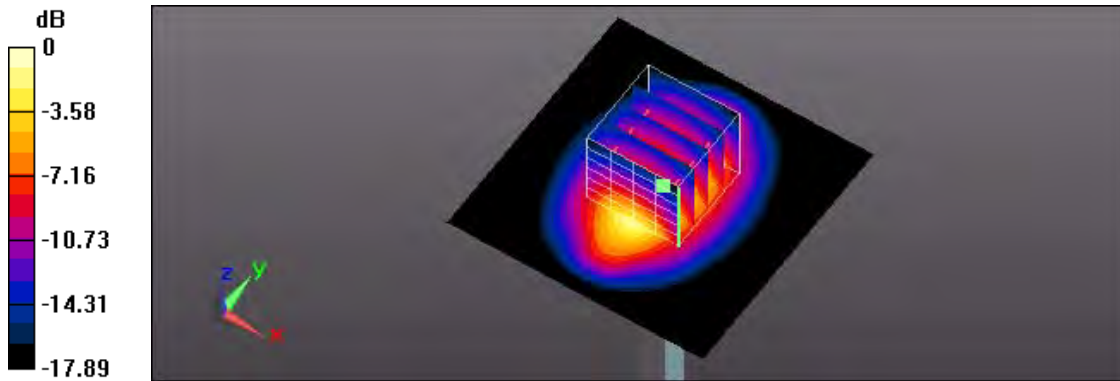

0 dB = 14.8 W/kg = 11.70 dBW/kg

Test Laboratory: A Test Lab Techno Corp.

Date/Time: 2019/5/7

**System Performance Check at 1900MHz\_20190507\_Body**

**DUT: Dipole 1900MHz; Type: D1900V2; Serial: D1900V2 - SN:5d111**

Communication System: UID 0, CW (0); Frequency: 1900 MHz; Duty Cycle: 1:1

Medium parameters used:  $f = 1900$  MHz;  $\sigma = 1.579$  S/m;  $\epsilon_r = 52.694$ ;  $\rho = 1000$  kg/m<sup>3</sup>

Phantom section: Flat Section

Measurement Standard: DASYS (IEEE/IEC/ANSI C63.19-2007)

DASY5.2 Configuration:

- Area Scan setting - Find Secondary Maximum Within: 2.0dB and with a peak SAR value greater than 0.5 W/Kg
- Probe: EX3DV4 - SN3578; ConvF(7.68, 7.68, 7.68); Calibrated: 2018/5/29
- Sensor-Surface: 1.4mm (Mechanical Surface Detection)
- Electronics: DAE4 Sn541; Calibrated: 2019/3/19
- Phantom: ELI v4.0; Type: QDOVA001BB; Serial: TP:1036
- Measurement SW: DASYS2, Version 52.10 (2); SEMCAD X Version 14.6.12 (7450)

**System Performance Check at 1900MHz/Area Scan (61x61x1):** Interpolated grid: dx=1.500 mm, dy=1.500 mm

Maximum value of SAR (interpolated) = 16.7 W/kg

**System Performance Check at 1900MHz/Zoom Scan (5x5x7)/Cube 0:** Measurement grid: dx=8mm, dy=8mm, dz=5mm

Reference Value = 105.7 V/m; Power Drift = 0.03 dB

Peak SAR (extrapolated) = 20.0 W/kg

**SAR(1 g) = 10.5 W/kg; SAR(10 g) = 5.42 W/kg**

Maximum value of SAR (measured) = 16.6 W/kg

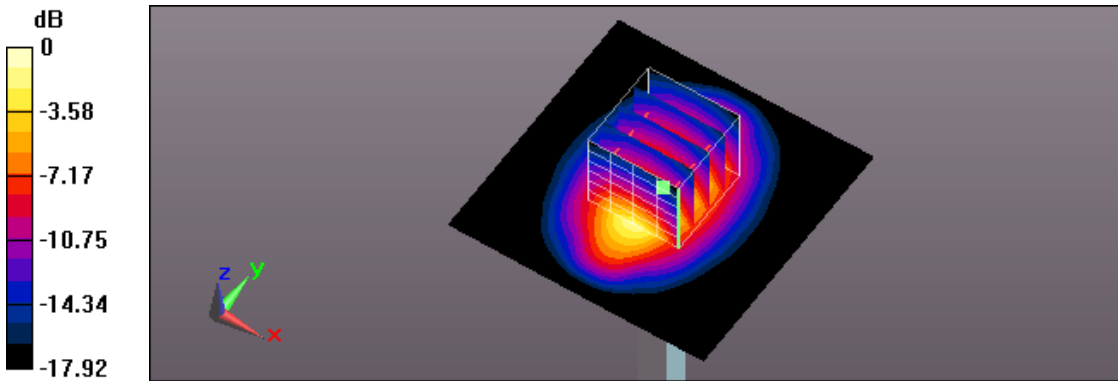

0 dB = 16.6 W/kg = 12.20 dBW/kg

Test Laboratory: A Test Lab Techno Corp.

Date/Time: 2019/5/9

**System Performance Check at 2450MHz\_20190509\_Body**

**DUT: Dipole 2450 MHz; Type: D2450V2; Serial: D2450V2 - SN:735**

Communication System: UID 0, CW (0); Frequency: 2450 MHz; Duty Cycle: 1:1

Medium parameters used:  $f = 2450$  MHz;  $\sigma = 1.971$  S/m;  $\epsilon_r = 51.951$ ;  $\rho = 1000$  kg/m<sup>3</sup>

Phantom section: Flat Section

Measurement Standard: DASY5 (IEEE/IEC/ANSI C63.19-2007)

DASY5.2 Configuration:

- Area Scan setting - Find Secondary Maximum Within: 2.0dB and with a peak SAR value greater than 0.5 W/Kg
- Probe: EX3DV4 - SN3578; ConvF(7.44, 7.44, 7.44); Calibrated: 2018/5/29
- Sensor-Surface: 1.4mm (Mechanical Surface Detection)
- Electronics: DAE4 Sn541; Calibrated: 2019/3/19
- Phantom: ELI v4.0; Type: QDOVA001BB; Serial: TP:1036
- Measurement SW: DASY52, Version 52.10 (2); SEMCAD X Version 14.6.12 (7450)

**System Performance Check at 2450MHz/Area Scan (81x81x1):** Interpolated grid: dx=1.200 mm, dy=1.200 mm

Maximum value of SAR (interpolated) = 22.6 W/kg

**System Performance Check at 2450MHz/Zoom Scan (7x7x7)/Cube 0:** Measurement grid: dx=5mm, dy=5mm, dz=5mm

Reference Value = 112.6 V/m; Power Drift = 0.09 dB

Peak SAR (extrapolated) = 28.6 W/kg

**SAR(1 g) = 13.2 W/kg; SAR(10 g) = 5.8 W/kg**

Maximum value of SAR (measured) = 23.0 W/kg

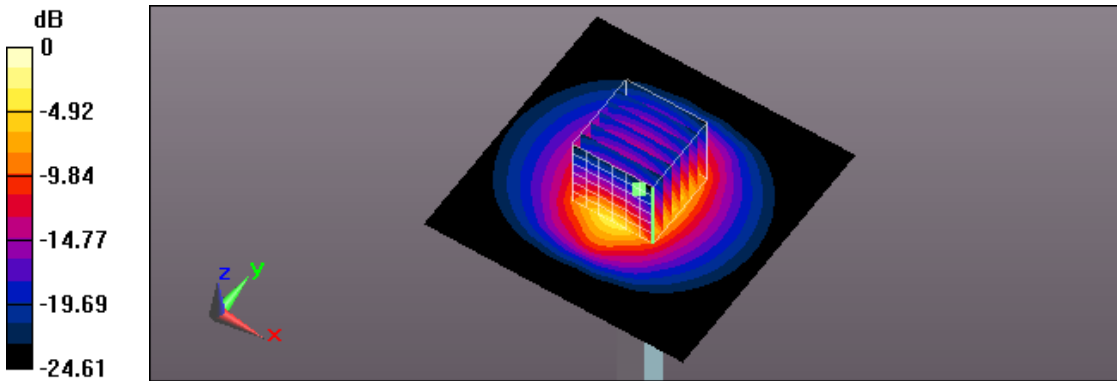

0 dB = 23.0 W/kg = 13.62 dBW/kg

Test Laboratory: A Test Lab Techno Corp.

Date/Time: 2019/5/9

**System Performance Check at 5200MHz\_20190509\_Body**

**DUT: Dipole D5GHzV2; Type: D5GHzV2; Serial: D5GHzV2 - SN:1021**

Communication System: UID 0, CW (0); Frequency: 5200 MHz; Duty Cycle: 1:1

Medium parameters used:  $f = 5200 \text{ MHz}$ ;  $\sigma = 5.136 \text{ S/m}$ ;  $\epsilon_r = 48.83$ ;  $\rho = 1000 \text{ kg/m}^3$

Phantom section: Flat Section

Measurement Standard: DASYS (IEEE/IEC/ANSI C63.19-2007)

DASY5.2 Configuration:

- Area Scan setting - Find Secondary Maximum Within: 2.0dB and with a peak SAR value greater than 0.5 W/Kg
- Probe: EX3DV4 - SN3578; ConvF(4.96, 4.96, 4.96); Calibrated: 2018/5/29
- Sensor-Surface: 1.4mm (Mechanical Surface Detection)
- Electronics: DAE4 Sn541; Calibrated: 2019/3/19
- Phantom: ELI v4.0; Type: QDOVA001BB; Serial: TP:1036
- Measurement SW: DASYS2, Version 52.10 (2); SEMCAD X Version 14.6.12 (7450)

**System Performance Check at 5200MHz/Area Scan (91x91x1):** Interpolated grid:  $dx=1.000 \text{ mm}$ ,  $dy=1.000 \text{ mm}$

Maximum value of SAR (interpolated) = 18.3 W/kg

**System Performance Check at 5200MHz/Zoom Scan (7x7x7)/Cube 0:** Measurement grid:  $dx=4\text{mm}$ ,  $dy=4\text{mm}$ ,  $dz=1.4\text{mm}$

Reference Value = 69.50 V/m; Power Drift = -0.07 dB

Peak SAR (extrapolated) = 32.7 W/kg

**SAR(1 g) = 7.71 W/kg; SAR(10 g) = 2.08 W/kg**

Maximum value of SAR (measured) = 19.7 W/kg

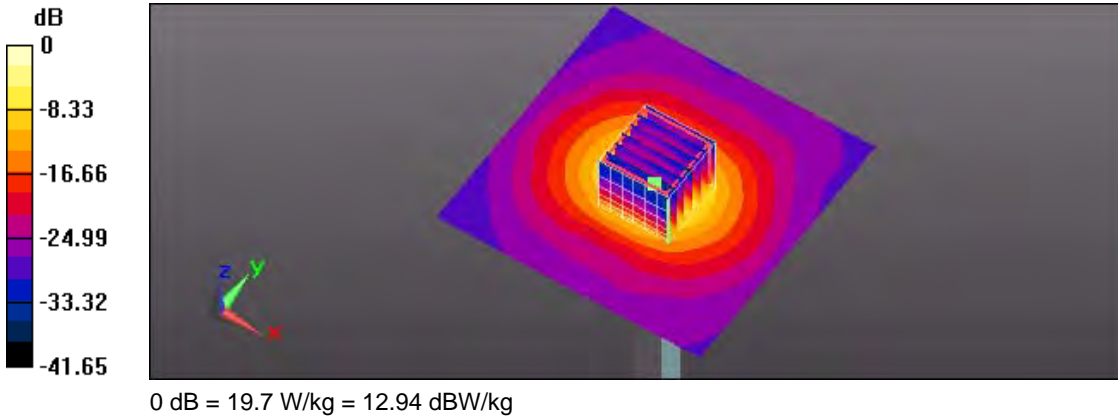



Test Laboratory: A Test Lab Techno Corp.

Date/Time: 2019/5/9

**System Performance Check at 5500MHz\_20190509\_Body**

**DUT: Dipole D5GHzV2; Type: D5GHzV2; Serial: D5GHzV2 - SN:1021**

Communication System: UID 0, CW (0); Frequency: 5500 MHz; Duty Cycle: 1:1

Medium parameters used:  $f = 5500$  MHz;  $\sigma = 5.532$  S/m;  $\epsilon_r = 48.225$ ;  $\rho = 1000$  kg/m<sup>3</sup>

Phantom section: Flat Section

Measurement Standard: DASYS (IEEE/IEC/ANSI C63.19-2007)

DASY5.2 Configuration:

- Area Scan setting - Find Secondary Maximum Within: 2.0dB and with a peak SAR value greater than 0.5 W/Kg
- Probe: EX3DV4 - SN3578; ConvF(4.22, 4.22, 4.22); Calibrated: 2018/5/29
- Sensor-Surface: 1.4mm (Mechanical Surface Detection)
- Electronics: DAE4 Sn541; Calibrated: 2019/3/19
- Phantom: ELI v4.0; Type: QDOVA001BB; Serial: TP:1036
- Measurement SW: DASYS2, Version 52.10 (2); SEMCAD X Version 14.6.12 (7450)

**System Performance Check at 5500MHz/Area Scan (91x91x1):** Interpolated grid: dx=1.000 mm, dy=1.000 mm

Maximum value of SAR (interpolated) = 20.8 W/kg

**System Performance Check at 5500MHz/Zoom Scan (7x7x7)/Cube 0:** Measurement grid: dx=4mm, dy=4mm, dz=1.4mm

Reference Value = 71.27 V/m; Power Drift = -0.07 dB

Peak SAR (extrapolated) = 39.8 W/kg

**SAR(1 g) = 8.49 W/kg; SAR(10 g) = 2.3 W/kg**

Maximum value of SAR (measured) = 22.0 W/kg

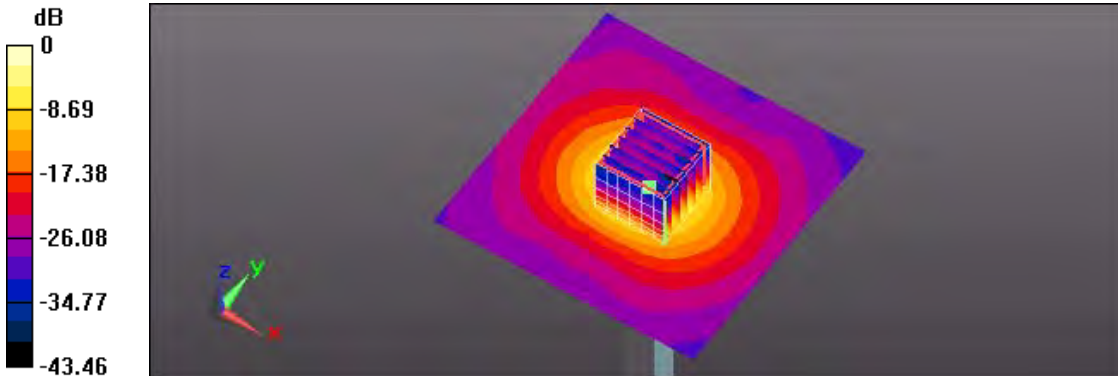

0 dB = 22.0 W/kg = 13.42 dBW/kg

Test Laboratory: A Test Lab Techno Corp.

Date/Time: 2019/5/9

**System Performance Check at 5800MHz\_20190509\_Body**

**DUT: Dipole D5GHzV2; Type: D5GHzV2; Serial: D5GHzV2 - SN:1021**

Communication System: UID 0, CW (0); Frequency: 5800 MHz; Duty Cycle: 1:1

Medium parameters used:  $f = 5800 \text{ MHz}$ ;  $\sigma = 5.93 \text{ S/m}$ ;  $\epsilon_r = 47.571$ ;  $\rho = 1000 \text{ kg/m}^3$

Phantom section: Flat Section

Measurement Standard: DASYS (IEEE/IEC/ANSI C63.19-2007)

DASY5.2 Configuration:

- Area Scan setting - Find Secondary Maximum Within: 2.0dB and with a peak SAR value greater than 0.5 W/Kg
- Probe: EX3DV4 - SN3578; ConvF(4.34, 4.34, 4.34); Calibrated: 2018/5/29
- Sensor-Surface: 1.4mm (Mechanical Surface Detection)
- Electronics: DAE4 Sn541; Calibrated: 2019/3/19
- Phantom: ELI v4.0; Type: QDOVA001BB; Serial: TP:1036
- Measurement SW: DASYS2, Version 52.10 (2); SEMCAD X Version 14.6.12 (7450)

**System Performance Check at 5800MHz/Area Scan (91x91x1):** Interpolated grid:  $dx=1.000 \text{ mm}$ ,  $dy=1.000 \text{ mm}$

Maximum value of SAR (interpolated) = 20.7 W/kg

**System Performance Check at 5800MHz/Zoom Scan (7x7x7)/Cube 0:** Measurement grid:  $dx=4\text{mm}$ ,  $dy=4\text{mm}$ ,  $dz=1.4\text{mm}$

Reference Value = 68.72 V/m; Power Drift = -0.12 dB

Peak SAR (extrapolated) = 42.4 W/kg

**SAR(1 g) = 8.46 W/kg; SAR(10 g) = 2.26 W/kg**

Maximum value of SAR (measured) = 22.5 W/kg

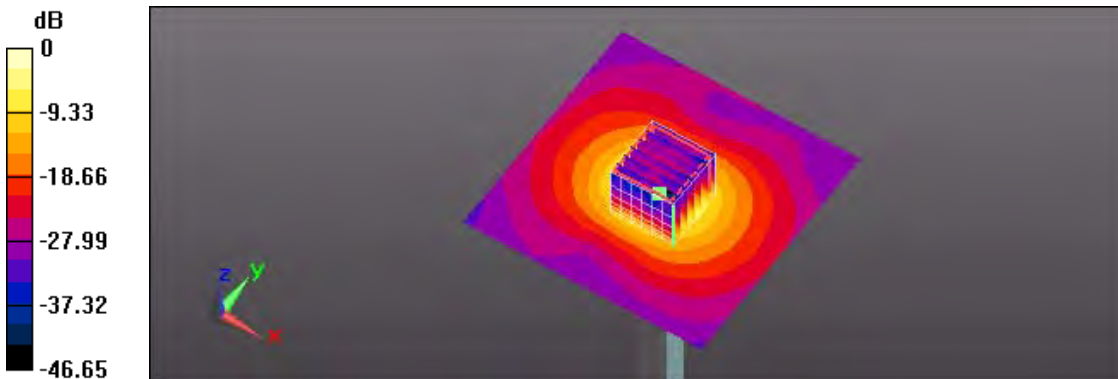

0 dB = 22.5 W/kg = 13.52 dBW/kg

## Appendix B - SAR Measurement Data

Test Laboratory: A Test Lab Techno Corp.

Date/Time: 2019/5/7

**03\_WCDMA Band II CH 9400\_Side 4\_0mm**

**DUT: SC20-A; Type: LTE Module**

Communication System: UID 0, WCDMA Band II (0); Frequency: 1880 MHz; Duty Cycle: 1:1

Medium parameters used:  $f = 1880$  MHz;  $\sigma = 1.56$  S/m;  $\epsilon_r = 52.727$ ;  $\rho = 1000$  kg/m<sup>3</sup>

Phantom section: Flat Section

Measurement Standard: DASYS (IEEE/IEC/ANSI C63.19-2007)

DASY5.2 Configuration:

- Area Scan setting - Find Secondary Maximum Within: 2.0dB and with a peak SAR value greater than 0.5 W/Kg
- Probe: EX3DV4 - SN3578; ConvF(7.68, 7.68, 7.68); Calibrated: 2018/5/29
- Sensor-Surface: 1.4mm (Mechanical Surface Detection)
- Electronics: DAE4 Sn541; Calibrated: 2019/3/19
- Phantom: ELI v4.0; Type: QDOVA001BB; Serial: TP:1036
- Measurement SW: DASYS2, Version 52.10 (2); SEMCAD X Version 14.6.12 (7450)

**Area Scan (61x81x1):** Interpolated grid: dx=1.500 mm, dy=1.500 mm

Maximum value of SAR (interpolated) = 1.37 W/kg

**Zoom Scan (5x5x7)/Cube 0:** Measurement grid: dx=8mm, dy=8mm, dz=5mm

Reference Value = 27.33 V/m; Power Drift = 0.05 dB

Peak SAR (extrapolated) = 1.67 W/kg

**SAR(1 g) = 0.906 W/kg; SAR(10 g) = 0.460 W/kg**

Maximum value of SAR (measured) = 1.39 W/kg

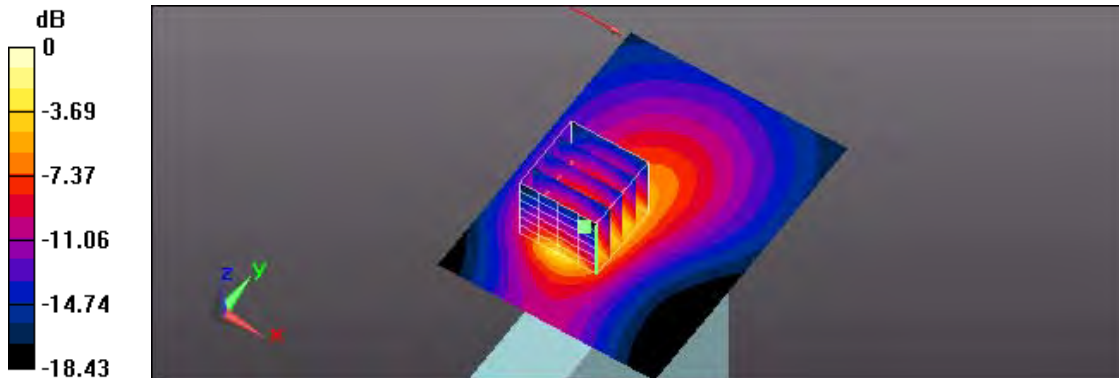

0 dB = 1.39 W/kg = 1.43 dBW/kg

Test Laboratory: A Test Lab Techno Corp.

Date/Time: 2019/5/8

**34\_WCDMA Band V CH 4132\_Back\_0mm**

**DUT: SC20-A; Type: LTE Module**

Communication System: UID 0, WCDMA Band V (0); Frequency: 826.4 MHz; Duty Cycle: 1:1

Medium parameters used (interpolated):  $f = 826.4$  MHz;  $\sigma = 0.991$  S/m;  $\epsilon_r = 56.991$ ;  $\rho = 1000$  kg/m<sup>3</sup>

Phantom section: Flat Section

Measurement Standard: DASYS5 (IEEE/IEC/ANSI C63.19-2007)

DASY5.2 Configuration:

- Area Scan setting - Find Secondary Maximum Within: 2.0dB and with a peak SAR value greater than 0.5 W/Kg
- Probe: EX3DV4 - SN3578; ConvF(9.49, 9.49, 9.49); Calibrated: 2018/5/29
- Sensor-Surface: 1.4mm (Mechanical Surface Detection)
- Electronics: DAE4 Sn541; Calibrated: 2019/3/19
- Phantom: ELI v4.0; Type: QDOVA001BB; Serial: TP:1036
- Measurement SW: DASYS52, Version 52.10 (2); SEMCAD X Version 14.6.12 (7450)

**Area Scan (61x81x1):** Interpolated grid: dx=1.500 mm, dy=1.500 mm

Maximum value of SAR (interpolated) = 0.643 W/kg

**Zoom Scan (5x5x7)/Cube 0:** Measurement grid: dx=8mm, dy=8mm, dz=5mm

Reference Value = 24.92 V/m; Power Drift = -0.06 dB

Peak SAR (extrapolated) = 0.735 W/kg

**SAR(1 g) = 0.477 W/kg; SAR(10 g) = 0.321 W/kg**

Maximum value of SAR (measured) = 0.633 W/kg

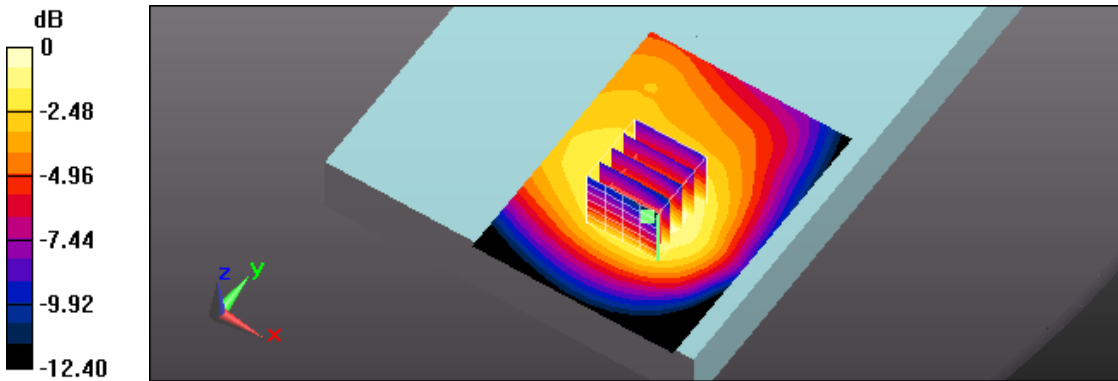

0 dB = 0.633 W/kg = -1.99 dBW/kg





Test Laboratory: A Test Lab Techno Corp.

Date/Time: 2019/5/7

**17\_LTE Band 2 CH 18900\_QPSK\_BW 20M\_1RB Size 0RB Offset\_Side 4\_0mm**

**DUT: SC20-A; Type: LTE Module**

Communication System: UID 0, Generic LTE (0); Frequency: 1880 MHz; Duty Cycle: 1:1

Medium parameters used:  $f = 1880$  MHz;  $\sigma = 1.56$  S/m;  $\epsilon_r = 52.727$ ;  $\rho = 1000$  kg/m<sup>3</sup>

Phantom section: Flat Section

Measurement Standard: DASYS5 (IEEE/IEC/ANSI C63.19-2007)

DASY5.2 Configuration:

- Area Scan setting - Find Secondary Maximum Within: 2.0dB and with a peak SAR value greater than 0.5 W/Kg
- Probe: EX3DV4 - SN3578; ConvF(7.68, 7.68, 7.68); Calibrated: 2018/5/29
- Sensor-Surface: 1.4mm (Mechanical Surface Detection)
- Electronics: DAE4 Sn541; Calibrated: 2019/3/19
- Phantom: ELI v4.0; Type: QDOVA001BB; Serial: TP:1036
- Measurement SW: DASYS52, Version 52.10 (2); SEMCAD X Version 14.6.12 (7450)

**Area Scan (61x81x1):** Interpolated grid: dx=1.500 mm, dy=1.500 mm

Maximum value of SAR (interpolated) = 1.53 W/kg

**Zoom Scan (5x5x7)/Cube 0:** Measurement grid: dx=8mm, dy=8mm, dz=5mm

Reference Value = 28.93 V/m; Power Drift = -0.10 dB

Peak SAR (extrapolated) = 1.86 W/kg

**SAR(1 g) = 1.01 W/kg; SAR(10 g) = 0.525 W/kg**

Maximum value of SAR (measured) = 1.52 W/kg

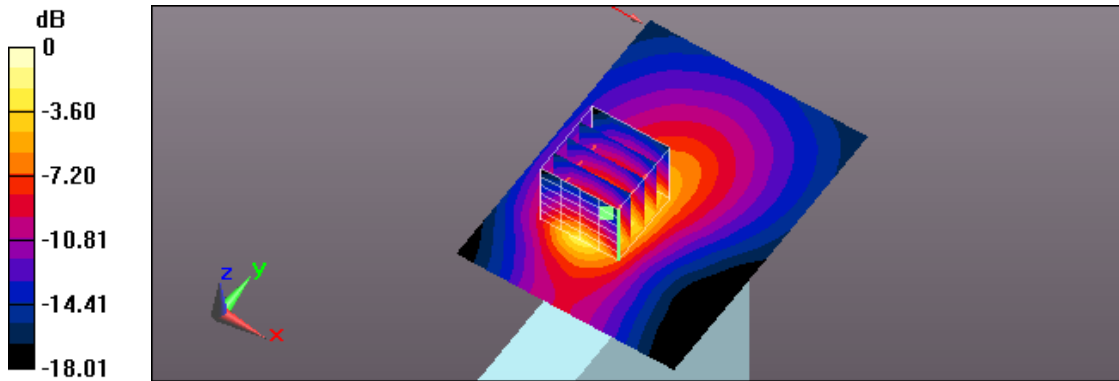

0 dB = 1.52 W/kg = 1.82 dBW/kg

Test Laboratory: A Test Lab Techno Corp.

Date/Time: 2019/5/8

**28\_LTE Band 4 CH 20175\_QPSK\_BW 20M\_1RB Size 0RB Offset\_Side 4\_0mm**

**DUT: SC20-A; Type: LTE Module**

Communication System: UID 0, Generic LTE (0); Frequency: 1732.5 MHz; Duty Cycle: 1:1

Medium parameters used (interpolated):  $f = 1732.5$  MHz;  $\sigma = 1.44$  S/m;  $\epsilon_r = 53.232$ ;  $\rho = 1000$  kg/m<sup>3</sup>

Phantom section: Flat Section

Measurement Standard: DASYS (IEEE/IEC/ANSI C63.19-2007)

DASY5.2 Configuration:

- Area Scan setting - Find Secondary Maximum Within: 2.0dB and with a peak SAR value greater than 0.5 W/Kg
- Probe: EX3DV4 - SN3578; ConvF(7.92, 7.92, 7.92); Calibrated: 2018/5/29
- Sensor-Surface: 1.4mm (Mechanical Surface Detection)
- Electronics: DAE4 Sn541; Calibrated: 2019/3/19
- Phantom: ELI v4.0; Type: QDOVA001BB; Serial: TP:1036
- Measurement SW: DASYS2, Version 52.10 (2); SEMCAD X Version 14.6.12 (7450)

**Area Scan (61x81x1):** Interpolated grid: dx=1.500 mm, dy=1.500 mm

Maximum value of SAR (interpolated) = 1.13 W/kg

**Zoom Scan (5x5x7)/Cube 0:** Measurement grid: dx=8mm, dy=8mm, dz=5mm

Reference Value = 24.35 V/m; Power Drift = 0.09 dB

Peak SAR (extrapolated) = 1.27 W/kg

**SAR(1 g) = 0.755 W/kg; SAR(10 g) = 0.418 W/kg**

Maximum value of SAR (measured) = 1.09 W/kg

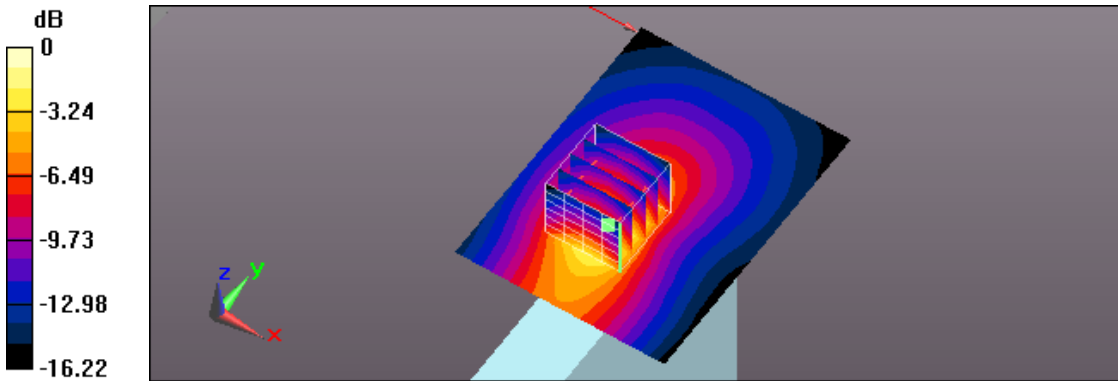

0 dB = 1.09 W/kg = 0.37 dBW/kg

Test Laboratory: A Test Lab Techno Corp.

Date/Time: 2019/5/8

**42\_LTE Band 5 CH 20525\_QPSK\_BW 10M\_1RB Size 0RB Offset\_Back\_0mm**

**DUT: SC20-A; Type: LTE Module**

Communication System: UID 0, Generic LTE (0); Frequency: 836.5 MHz; Duty Cycle: 1:1

Medium parameters used (interpolated):  $f = 836.5$  MHz;  $\sigma = 1$  S/m;  $\epsilon_r = 56.899$ ;  $\rho = 1000$  kg/m<sup>3</sup>

Phantom section: Flat Section

Measurement Standard: DASYS (IEEE/IEC/ANSI C63.19-2007)

DASY5.2 Configuration:

- Area Scan setting - Find Secondary Maximum Within: 2.0dB and with a peak SAR value greater than 0.5 W/Kg
- Probe: EX3DV4 - SN3578; ConvF(9.49, 9.49, 9.49); Calibrated: 2018/5/29
- Sensor-Surface: 1.4mm (Mechanical Surface Detection)
- Electronics: DAE4 Sn541; Calibrated: 2019/3/19
- Phantom: ELI v4.0; Type: QDOVA001BB; Serial: TP:1036
- Measurement SW: DASYS2, Version 52.10 (2); SEMCAD X Version 14.6.12 (7450)

**Area Scan (71x81x1):** Interpolated grid: dx=1.500 mm, dy=1.500 mm

Maximum value of SAR (interpolated) = 0.572 W/kg

**Zoom Scan (5x5x7)/Cube 0:** Measurement grid: dx=8mm, dy=8mm, dz=5mm

Reference Value = 25.18 V/m; Power Drift = -0.10 dB

Peak SAR (extrapolated) = 0.668 W/kg

**SAR(1 g) = 0.440 W/kg; SAR(10 g) = 0.296 W/kg**

Maximum value of SAR (measured) = 0.587 W/kg

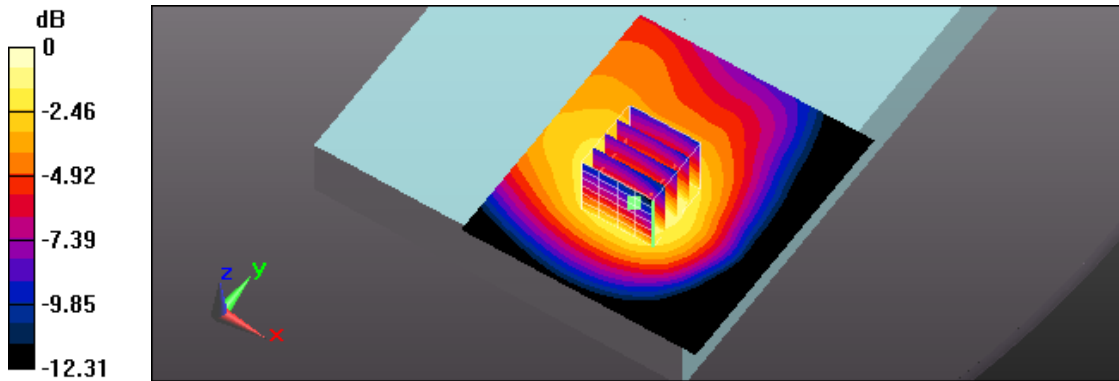

0 dB = 0.587 W/kg = -2.31 dBW/kg



Test Laboratory: A Test Lab Techno Corp.

Date/Time: 2019/5/8

**54\_LTE Band 12 CH 23095\_QPSK\_BW 10M\_1RB Size 24RB Offset\_Back\_0mm**

**DUT: SC20-A; Type: LTE Module**

Communication System: UID 0, Generic LTE (0); Frequency: 707.5 MHz; Duty Cycle: 1:1

Medium parameters used (interpolated):  $f = 707.5$  MHz;  $\sigma = 0.929$  S/m;  $\epsilon_r = 57.16$ ;  $\rho = 1000$  kg/m<sup>3</sup>

Phantom section: Flat Section

Measurement Standard: DASYS5 (IEEE/IEC/ANSI C63.19-2007)

DASY5.2 Configuration:

- Area Scan setting - Find Secondary Maximum Within: 2.0dB and with a peak SAR value greater than 0.5 W/Kg
- Probe: EX3DV4 - SN3578; ConvF(9.89, 9.89, 9.89); Calibrated: 2018/5/29
- Sensor-Surface: 1.4mm (Mechanical Surface Detection)
- Electronics: DAE4 Sn541; Calibrated: 2019/3/19
- Phantom: ELI v4.0; Type: QDOVA001BB; Serial: TP:1036
- Measurement SW: DASYS2, Version 52.10 (2); SEMCAD X Version 14.6.12 (7450)

**Area Scan (71x81x1):** Interpolated grid: dx=1.500 mm, dy=1.500 mm

Maximum value of SAR (interpolated) = 0.556 W/kg

**Zoom Scan (5x5x7)/Cube 0:** Measurement grid: dx=8mm, dy=8mm, dz=5mm

Reference Value = 25.68 V/m; Power Drift = 0.10 dB

Peak SAR (extrapolated) = 0.661 W/kg

**SAR(1 g) = 0.458 W/kg; SAR(10 g) = 0.338 W/kg**

Maximum value of SAR (measured) = 0.575 W/kg

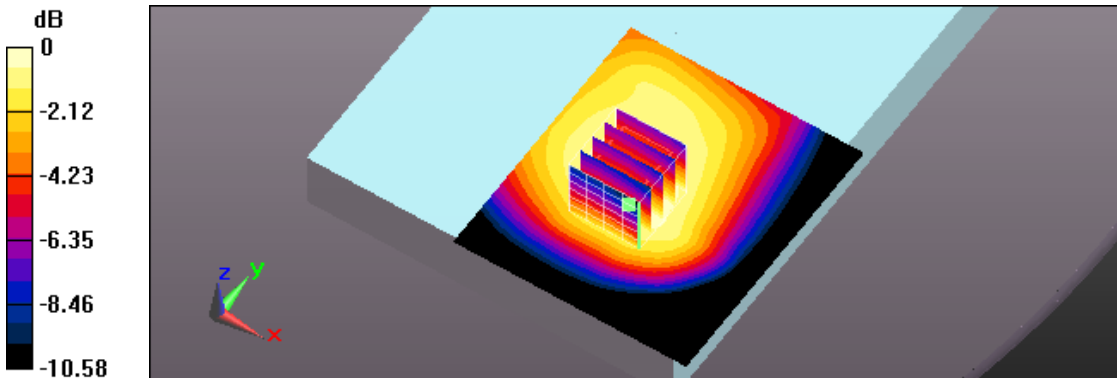

0 dB = 0.575 W/kg = -2.40 dBW/kg

Test Laboratory: A Test Lab Techno Corp.

Date/Time: 2019/5/9

**66\_ IEEE 802.11b CH6\_1M\_Back\_0mm**

**DUT: SC20-A; Type: LTE Module**

Communication System: UID 0, IEEE 802.11b (0); Frequency: 2437 MHz; Duty Cycle: 1:1.025

Medium parameters used:  $f = 2437$  MHz;  $\sigma = 1.956$  S/m;  $\epsilon_r = 51.979$ ;  $\rho = 1000$  kg/m<sup>3</sup>

Phantom section: Flat Section

Measurement Standard: DASY5 (IEEE/IEC/ANSI C63.19-2007)

DASY5.2 Configuration:

- Area Scan setting - Find Secondary Maximum Within: 2.0dB and with a peak SAR value greater than 0.5 W/Kg
- Probe: EX3DV4 - SN3578; ConvF(7.44, 7.44, 7.44); Calibrated: 2018/5/29
- Sensor-Surface: 1.4mm (Mechanical Surface Detection)
- Electronics: DAE4 Sn541; Calibrated: 2019/3/19
- Phantom: ELI v4.0; Type: QDOVA001BB; Serial: TP:1036
- Measurement SW: DASY52, Version 52.10 (2); SEMCAD X Version 14.6.12 (7450)

**Area Scan (81x101x1):** Interpolated grid: dx=1.200 mm, dy=1.200 mm

Maximum value of SAR (interpolated) = 0.402 W/kg

**Zoom Scan (7x7x7)/Cube 0:** Measurement grid: dx=5mm, dy=5mm, dz=5mm

Reference Value = 8.957 V/m; Power Drift = 0.04 dB

Peak SAR (extrapolated) = 0.178 W/kg

**SAR(1 g) = 0.105 W/kg; SAR(10 g) = 0.059 W/kg**

Maximum value of SAR (measured) = 0.151 W/kg

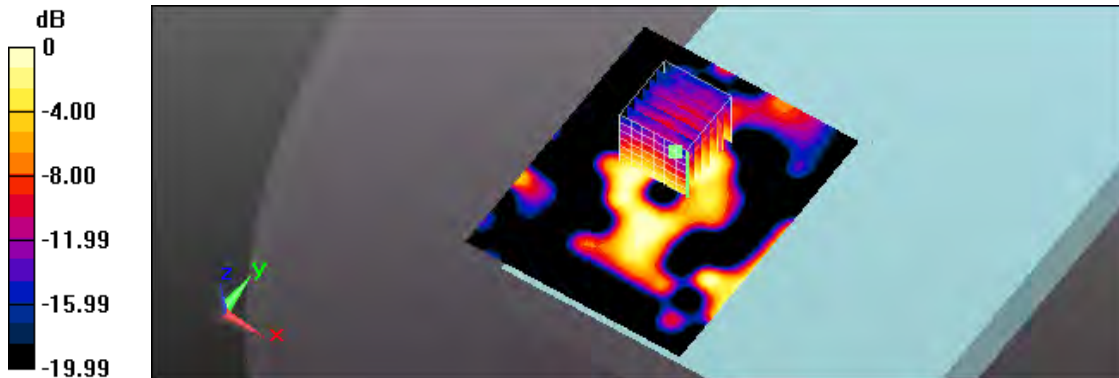

0 dB = 0.151 W/kg = -8.21 dBW/kg

Test Laboratory: A Test Lab Techno Corp.

Date/Time: 2019/5/9 PM 02:34:44

**73\_Bluetooth CH39\_1M\_Back\_0mm**

**DUT: SC20-A; Type: LTE Module**

Communication System: UID 0, Bluetooth 3.0 (0); Frequency: 2441 MHz; Duty Cycle: 1:1.089

Medium parameters used:  $f = 2441$  MHz;  $\sigma = 1.96$  S/m;  $\epsilon_r = 51.971$ ;  $\rho = 1000$  kg/m<sup>3</sup>

Phantom section: Flat Section

Measurement Standard: DASYS (IEEE/IEC/ANSI C63.19-2007)

DASY5.2 Configuration:

- Area Scan setting - Find Secondary Maximum Within: 2.0dB and with a peak SAR value greater than 0.5 W/Kg
- Probe: EX3DV4 - SN3578; ConvF(7.44, 7.44, 7.44) @ 2441 MHz; Calibrated: 2018/5/29
- Sensor-Surface: 1.4mm (Mechanical Surface Detection)
- Electronics: DAE4 Sn541; Calibrated: 2019/3/19
- Phantom: ELI v4.0; Type: QDOVA001BB; Serial: TP:1036
- Measurement SW: DASYS2, Version 52.10 (2); SEMCAD X Version 14.6.12 (7450)

**Area Scan (81x101x1):** Interpolated grid: dx=1.200 mm, dy=1.200 mm

Maximum value of SAR (interpolated) = 0.0469 W/kg

**Zoom Scan (7x7x7)/Cube 0:** Measurement grid: dx=5mm, dy=5mm, dz=5mm

Reference Value = 4.745 V/m; Power Drift = 0.03 dB

Peak SAR (extrapolated) = 0.0510 W/kg

**SAR(1 g) = 0.033 W/kg; SAR(10 g) = 0.020 W/kg**

Maximum value of SAR (measured) = 0.0445 W/kg

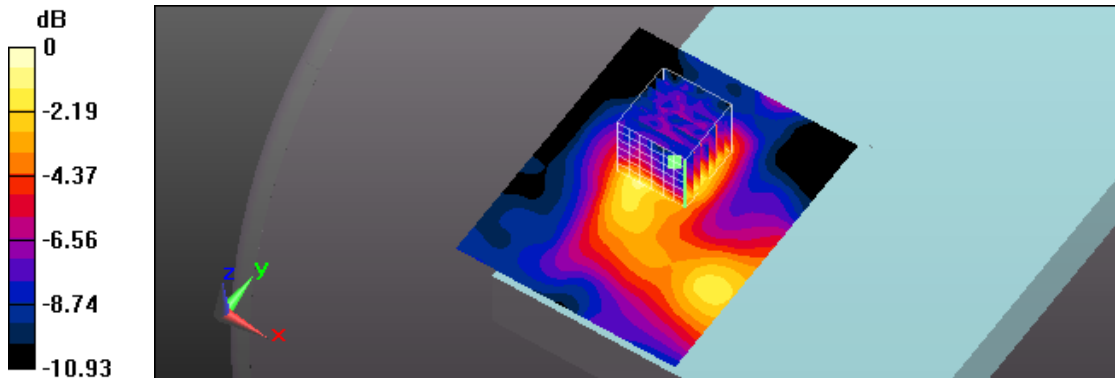

0 dB = 0.0445 W/kg = -13.52 dBW/kg

Test Laboratory: A Test Lab Techno Corp.

Date/Time: 2019/5/9

**80\_IEEE 802.11n20 CH64\_HT0\_Back\_0mm**

**DUT: SC20-A; Type: LTE Module**

Communication System: UID 0, IEEE 802.11n(5GHz)HT20 (0); Frequency: 5320 MHz;Duty Cycle: 1:1.186

Medium parameters used:  $f = 5320$  MHz;  $\sigma = 5.283$  S/m;  $\epsilon_r = 48.586$ ;  $\rho = 1000$  kg/m<sup>3</sup>

Phantom section: Flat Section

Measurement Standard: DASY5 (IEEE/IEC/ANSI C63.19-2007)

DASY5.2 Configuration:

- Area Scan setting - Find Secondary Maximum Within:2.0dB and with a peak SAR value greater than 0.5 W/Kg
- Probe: EX3DV4 - SN3578; ConvF(4.96, 4.96, 4.96); Calibrated: 2018/5/29
- Sensor-Surface: 1.4mm (Mechanical Surface Detection)
- Electronics: DAE4 Sn541; Calibrated: 2019/3/19
- Phantom: ELI v4.0; Type: QDOVA001BB; Serial: TP:1036
- Measurement SW: DASY52, Version 52.10 (2); SEMCAD X Version 14.6.12 (7450)

**Area Scan (91x121x1):** Interpolated grid: dx=1.000 mm, dy=1.000 mm

Maximum value of SAR (interpolated) = 0.247 W/kg

**Zoom Scan (7x7x7)/Cube 0:** Measurement grid: dx=4mm, dy=4mm, dz=1.4mm

Reference Value = 6.535 V/m; Power Drift = 0.15 dB

Peak SAR (extrapolated) = 0.403 W/kg

**SAR(1 g) = 0.104 W/kg; SAR(10 g) = 0.038 W/kg**

Maximum value of SAR (measured) = 0.226 W/kg

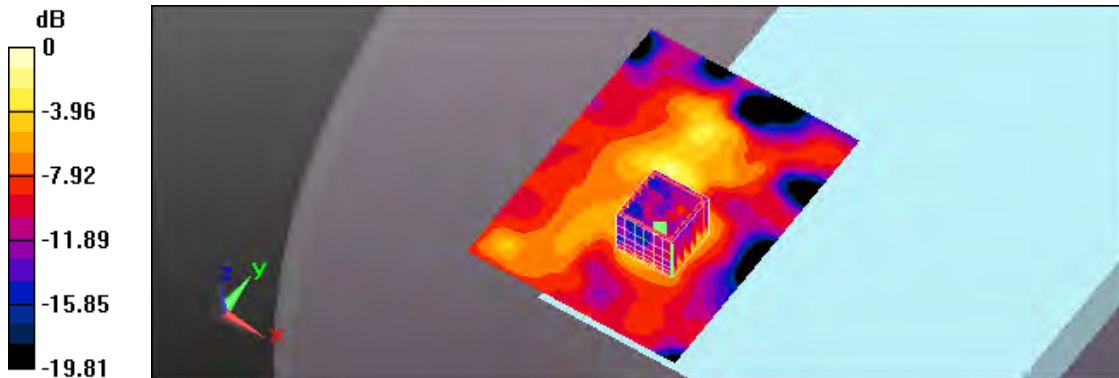

0 dB = 0.226 W/kg = -6.46 dBW/kg

Test Laboratory: A Test Lab Techno Corp.

Date/Time: 2019/5/9

**86\_IEEE 802.11n20 CH132\_HT0\_Back\_0mm**

**DUT: SC20-A; Type: LTE Module**

Communication System: UID 0, IEEE 802.11n(5GHz)HT20 (0); Frequency: 5660 MHz;Duty Cycle: 1:1.186

Medium parameters used:  $f = 5660 \text{ MHz}$ ;  $\sigma = 5.732 \text{ S/m}$ ;  $\epsilon_r = 47.867$ ;  $\rho = 1000 \text{ kg/m}^3$

Phantom section: Flat Section

Measurement Standard: DASY5 (IEEE/IEC/ANSI C63.19-2007)

DASY5.2 Configuration:

- Area Scan setting - Find Secondary Maximum Within:2.0dB and with a peak SAR value greater than 0.5 W/Kg
- Probe: EX3DV4 - SN3578; ConvF(4.22, 4.22, 4.22); Calibrated: 2018/5/29
- Sensor-Surface: 1.4mm (Mechanical Surface Detection)
- Electronics: DAE4 Sn541; Calibrated: 2019/3/19
- Phantom: ELI v4.0; Type: QDOVA001BB; Serial: TP:1036
- Measurement SW: DASY52, Version 52.10 (2); SEMCAD X Version 14.6.12 (7450)

**Area Scan (91x121x1):** Interpolated grid:  $dx=1.000 \text{ mm}$ ,  $dy=1.000 \text{ mm}$

Maximum value of SAR (interpolated) = 0.313 W/kg

**Zoom Scan (7x7x7)/Cube 0:** Measurement grid:  $dx=4\text{mm}$ ,  $dy=4\text{mm}$ ,  $dz=1.4\text{mm}$

Reference Value = 7.107 V/m; Power Drift = 0.15 dB

Peak SAR (extrapolated) = 0.611 W/kg

**SAR(1 g) = 0.135 W/kg; SAR(10 g) = 0.050 W/kg**

Maximum value of SAR (measured) = 0.313 W/kg

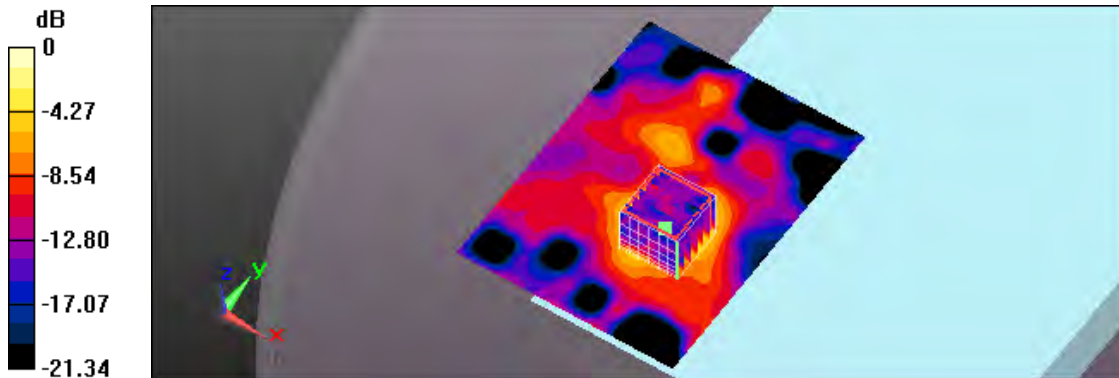

0 dB = 0.313 W/kg = -5.04 dBW/kg



Test Laboratory: A Test Lab Techno Corp.

Date/Time: 2019/5/9

**90\_ IEEE 802.11a CH165\_6M\_Back\_0mm**

**DUT: SC20-A; Type: LTE Module**

Communication System: UID 0, IEEE 802.11a (0); Frequency: 5825 MHz; Duty Cycle: 1:1.114

Medium parameters used:  $f = 5825 \text{ MHz}$ ;  $\sigma = 5.961 \text{ S/m}$ ;  $\epsilon_r = 47.563$ ;  $\rho = 1000 \text{ kg/m}^3$

Phantom section: Flat Section

Measurement Standard: DASYS (IEEE/IEC/ANSI C63.19-2007)

DASY5.2 Configuration:

- Area Scan setting - Find Secondary Maximum Within: 2.0dB and with a peak SAR value greater than 0.5 W/Kg
- Probe: EX3DV4 - SN3578; ConvF(4.34, 4.34, 4.34); Calibrated: 2018/5/29
- Sensor-Surface: 1.4mm (Mechanical Surface Detection)
- Electronics: DAE4 Sn541; Calibrated: 2019/3/19
- Phantom: ELI v4.0; Type: QDOVA001BB; Serial: TP:1036
- Measurement SW: DASYS2, Version 52.10 (2); SEMCAD X Version 14.6.12 (7450)

**Area Scan (91x121x1):** Interpolated grid:  $dx=1.000 \text{ mm}$ ,  $dy=1.000 \text{ mm}$

Maximum value of SAR (interpolated) = 0.348 W/kg

**Zoom Scan (7x7x7)/Cube 0:** Measurement grid:  $dx=4\text{mm}$ ,  $dy=4\text{mm}$ ,  $dz=1.4\text{mm}$

Reference Value = 6.934 V/m; Power Drift = 0.07 dB

Peak SAR (extrapolated) = 0.629 W/kg

**SAR(1 g) = 0.145 W/kg; SAR(10 g) = 0.053 W/kg**

Maximum value of SAR (measured) = 0.327 W/kg

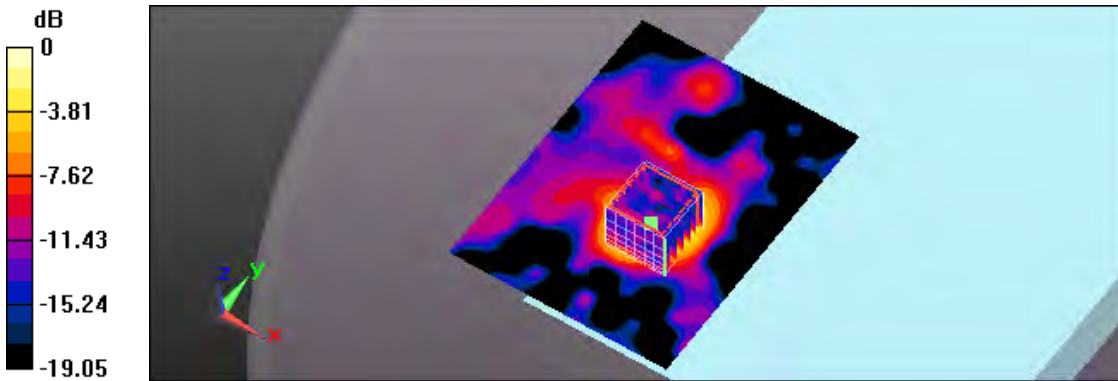

0 dB = 0.327 W/kg = -4.85 dBW/kg



## ***Appendix C - Calibration***

All of the instruments Calibration information are listed below.

- Dipole \_ D750V3 SN:1004
- Dipole \_ D835V2 SN:4d082
- Dipole \_ D1750V2 SN:1023
- Dipole \_ D1900V2 SN:5d111
- Dipole \_ D2450V2 SN:735
- Dipole \_ D5GHzV2 SN:1021
- Probe \_ EX3DV4 SN:3578
- DAE \_ DAE4 SN:541



57-044\_18-245



In Collaboration with  
**s p e a g**  
CALIBRATION LABORATORY



中国认可  
国际互认  
校准  
CALIBRATION  
CNAS L0570

Add: No.51 Xueyuan Road, Haidian District, Beijing, 100191, China  
Tel: +86-10-62304633-2079 Fax: +86-10-62304633-2504  
E-mail: cttl@chinattl.com http://www.chinattl.cn

Client **ATL**

Certificate No: **Z18-60307**

### CALIBRATION CERTIFICATE

Object: **D750V3 - SN: 1004**

Calibration Procedure(s): **FF-Z11-003-01**  
Calibration Procedures for dipole validation kits

Calibration date: **September 5, 2018**

This calibration Certificate documents the traceability to national standards, which realize the physical units of measurements(SI). The measurements and the uncertainties with confidence probability are given on the following pages and are part of the certificate.

All calibrations have been conducted in the closed laboratory facility: environment temperature(22±3)°C and humidity<70%.

Calibration Equipment used (M&TE critical for calibration)

Primary Standards	ID #	Cal Date(Calibrated by, Certificate No.)	Scheduled Calibration
Power Meter NRVD	102083	01-Nov-17 (CTTL, No.J17X08756)	Oct-18
Power sensor NRV-Z5	100542	01-Nov-17 (CTTL, No.J17X08756)	Oct-18
Reference Probe EX3DV4	SN 7464	12-Sep-17(SPEAG,No.EX3-7464_Sep17)	Sep-18
DAE4	SN 1524	13-Sep-17(SPEAG,No.DAE4-1524_Sep17)	Sep-18
Secondary Standards	ID #	Cal Date(Calibrated by, Certificate No.)	Scheduled Calibration
Signal Generator E4438C	MY49071430	23-Jan-18 (CTTL, No.J18X00560)	Jan-19
NetworkAnalyzer E5071C	MY46110673	24-Jan-18 (CTTL, No.J18X00561)	Jan-19

	Name	Function	Signature
Calibrated by:	Zhao Jing	SAR Test Engineer	
Reviewed by:	Lin Hao	SAR Test Engineer	
Approved by:	Qi Dianyuan	SAR Project Leader	

Issued: September 8, 2018

This calibration certificate shall not be reproduced except in full without written approval of the laboratory.

**Glossary:**

TSL	tissue simulating liquid
ConvF	sensitivity in TSL / NORM <sub>x,y,z</sub>
N/A	not applicable or not measured

**Calibration is Performed According to the Following Standards:**

- IEEE Std 1528-2013, "IEEE Recommended Practice for Determining the Peak Spatial-Averaged Specific Absorption Rate (SAR) in the Human Head from Wireless Communications Devices: Measurement Techniques", June 2013
- IEC 62209-1, "Measurement procedure for assessment of specific absorption rate of human exposure to radio frequency fields from hand-held and body-mounted wireless communication devices- Part 1: Device used next to the ear (Frequency range of 300MHz to 6GHz)", July 2016
- IEC 62209-2, "Procedure to measure the Specific Absorption Rate (SAR) For wireless communication devices used in close proximity to the human body (frequency range of 30MHz to 6GHz)", March 2010
- KDB865664, SAR Measurement Requirements for 100 MHz to 6 GHz

**Additional Documentation:**

- DASY4/5 System Handbook

**Methods Applied and Interpretation of Parameters:**

- Measurement Conditions:* Further details are available from the Validation Report at the end of the certificate. All figures stated in the certificate are valid at the frequency indicated.
- Antenna Parameters with TSL:* The dipole is mounted with the spacer to position its feed point exactly below the center marking of the flat phantom section, with the arms oriented parallel to the body axis.
- Feed Point Impedance and Return Loss:* These parameters are measured with the dipole positioned under the liquid filled phantom. The impedance stated is transformed from the measurement at the SMA connector to the feed point. The Return Loss ensures low reflected power. No uncertainty required.
- Electrical Delay:* One-way delay between the SMA connector and the antenna feed point. No uncertainty required.
- SAR measured:* SAR measured at the stated antenna input power.
- SAR normalized:* SAR as measured, normalized to an input power of 1 W at the antenna connector.
- SAR for nominal TSL parameters:* The measured TSL parameters are used to calculate the nominal SAR result.

The reported uncertainty of measurement is stated as the standard uncertainty of Measurement multiplied by the coverage factor  $k=2$ , which for a normal distribution Corresponds to a coverage probability of approximately 95%.

### Measurement Conditions

DASY system configuration, as far as not given on page 1.

<b>DASY Version</b>	DASY52	52.10.1.1476
<b>Extrapolation</b>	Advanced Extrapolation	
<b>Phantom</b>	Triple Flat Phantom 5.1C	
<b>Distance Dipole Center - TSL</b>	15 mm	with Spacer
<b>Zoom Scan Resolution</b>	dx, dy, dz = 5 mm	
<b>Frequency</b>	750 MHz ± 1 MHz	

### Head TSL parameters

The following parameters and calculations were applied.

	Temperature	Permittivity	Conductivity
<b>Nominal Head TSL parameters</b>	22.0 °C	41.9	0.89 mho/m
<b>Measured Head TSL parameters</b>	(22.0 ± 0.2) °C	43.1 ± 6 %	0.87 mho/m ± 6 %
<b>Head TSL temperature change during test</b>	<1.0 °C	----	----

### SAR result with Head TSL

SAR averaged over 1 cm <sup>3</sup> (1 g) of Head TSL	Condition	
SAR measured	250 mW input power	2.06 mW / g
SAR for nominal Head TSL parameters	normalized to 1W	<b>8.47 mW /g ± 18.8 % (k=2)</b>
SAR averaged over 10 cm <sup>3</sup> (10 g) of Head TSL	Condition	
SAR measured	250 mW input power	1.39 mW / g
SAR for nominal Head TSL parameters	normalized to 1W	<b>5.68 mW /g ± 18.7 % (k=2)</b>

### Body TSL parameters

The following parameters and calculations were applied.

	Temperature	Permittivity	Conductivity
<b>Nominal Body TSL parameters</b>	22.0 °C	55.5	0.96 mho/m
<b>Measured Body TSL parameters</b>	(22.0 ± 0.2) °C	56.8 ± 6 %	0.93 mho/m ± 6 %
<b>Body TSL temperature change during test</b>	<1.0 °C	----	----

### SAR result with Body TSL

SAR averaged over 1 cm <sup>3</sup> (1 g) of Body TSL	Condition	
SAR measured	250 mW input power	2.14 mW / g
SAR for nominal Body TSL parameters	normalized to 1W	<b>8.80 mW /g ± 18.8 % (k=2)</b>
SAR averaged over 10 cm <sup>3</sup> (10 g) of Body TSL	Condition	
SAR measured	250 mW input power	1.46 mW / g
SAR for nominal Body TSL parameters	normalized to 1W	<b>5.97 mW /g ± 18.7 % (k=2)</b>



Add: No.51 Xueyuan Road, Haidian District, Beijing, 100191, China  
 Tel: +86-10-62304633-2079 Fax: +86-10-62304633-2504  
 E-mail: cttl@chinattl.com http://www.chinattl.cn

**Appendix (Additional assessments outside the scope of CNAS L0570)**

**Antenna Parameters with Head TSL**

Impedance, transformed to feed point	54.4Ω+ 0.96jΩ
Return Loss	- 27.3dB

**Antenna Parameters with Body TSL**

Impedance, transformed to feed point	48.2Ω- 1.43jΩ
Return Loss	- 32.5dB

**General Antenna Parameters and Design**

Electrical Delay (one direction)	0.906 ns
----------------------------------	----------

After long term use with 100W radiated power, only a slight warming of the dipole near the feedpoint can be measured.

The dipole is made of standard semirigid coaxial cable. The center conductor of the feeding line is directly connected to the second arm of the dipole. The antenna is therefore short-circuited for DC-signals. On some of the dipoles, small end caps are added to the dipole arms in order to improve matching when loaded according to the position as explained in the "Measurement Conditions" paragraph. The SAR data are not affected by this change. The overall dipole length is still according to the Standard. No excessive force must be applied to the dipole arms, because they might bend or the soldered connections near the feedpoint may be damaged.

**Additional EUT Data**

Manufactured by	SPEAG
-----------------	-------

**DASY5 Validation Report for Head TSL**

Date: 09.05.2018

Test Laboratory: CTTL, Beijing, China

**DUT: Dipole 750 MHz; Type: D750V3; Serial: D750V3 - SN: 1004**

Communication System: UID 0, CW; Frequency: 750 MHz; Duty Cycle: 1:1

Medium parameters used:  $f = 750 \text{ MHz}$ ;  $\sigma = 0.866 \text{ S/m}$ ;  $\epsilon_r = 43.13$ ;  $\rho = 1000 \text{ kg/m}^3$

Phantom section: Right Section

DASY5 Configuration:

- Probe: EX3DV4 - SN7464; ConvF(10.57, 10.57, 10.57) @ 750 MHz; Calibrated: 9/12/2017
- Sensor-Surface: 1.4mm (Mechanical Surface Detection)
- Electronics: DAE4 Sn1524; Calibrated: 9/13/2017
- Phantom: MFP\_V5.1C ; Type: QD 000 P51CA; Serial: 1062
- Measurement SW: DASY52, Version 52.10 (1); SEMCAD X Version 14.6.11 (7439)

**Dipole Calibration/Zoom Scan (7x7x7) (7x7x7)/Cube 0:** Measurement grid:  $dx=5\text{mm}$ ,  $dy=5\text{mm}$ ,  $dz=5\text{mm}$

Reference Value = 55.10 V/m; Power Drift = -0.07 dB

Peak SAR (extrapolated) = 3.01 W/kg

**SAR(1 g) = 2.06 W/kg; SAR(10 g) = 1.39 W/kg**

Maximum value of SAR (measured) = 2.69 W/kg

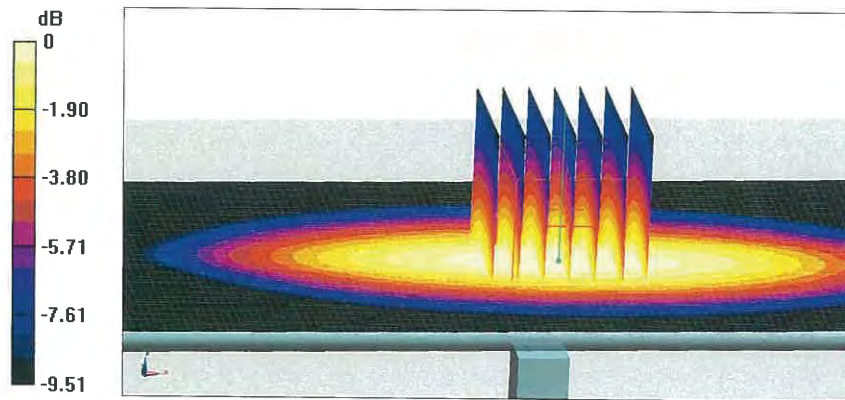



In Collaboration with  
**s p e a g**  
CALIBRATION LABORATORY

Add: No.51 Xueyuan Road, Haidian District, Beijing, 100191, China  
Tel: +86-10-62304633-2079 Fax: +86-10-62304633-2504  
E-mail: cttl@chinattl.com http://www.chinattl.cn

### Impedance Measurement Plot for Head TSL

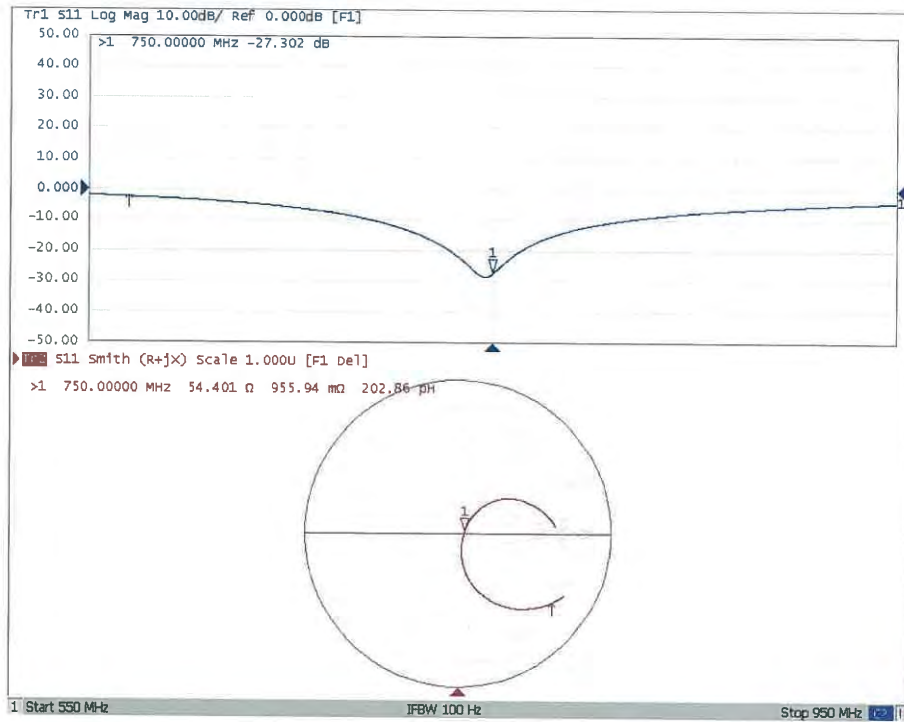



**DASY5 Validation Report for Body TSL**

Date: 09.05.2018

Test Laboratory: CTTL, Beijing, China

**DUT: Dipole 750 MHz; Type: D750V3; Serial: D750V3 - SN: 1004**

Communication System: UID 0, CW; Frequency: 750 MHz; Duty Cycle: 1:1

Medium parameters used:  $f = 750 \text{ MHz}$ ;  $\sigma = 0.932 \text{ S/m}$ ;  $\epsilon_r = 56.82$ ;  $\rho = 1000 \text{ kg/m}^3$

Phantom section: Center Section

DASY5 Configuration:

- Probe: EX3DV4 - SN7464; ConvF(10.63, 10.63, 10.63) @ 750 MHz; Calibrated: 9/12/2017
- Sensor-Surface: 1.4mm (Mechanical Surface Detection)
- Electronics: DAE4 Sn1524; Calibrated: 9/13/2017
- Phantom: MFP\_V5.1C ; Type: QD 000 P51CA; Serial: 1062
- Measurement SW: DASY52, Version 52.10 (1); SEMCAD X Version 14.6.11 (7439)

**Dipole Calibration/Zoom Scan (7x7x7) (7x7x7)/Cube 0:** Measurement grid:  $dx=5\text{mm}$ ,  $dy=5\text{mm}$ ,  $dz=5\text{mm}$

Reference Value = 54.38 V/m; Power Drift = -0.05 dB

Peak SAR (extrapolated) = 3.08 W/kg

**SAR(1 g) = 2.14 W/kg; SAR(10 g) = 1.46 W/kg**

Maximum value of SAR (measured) = 2.77 W/kg

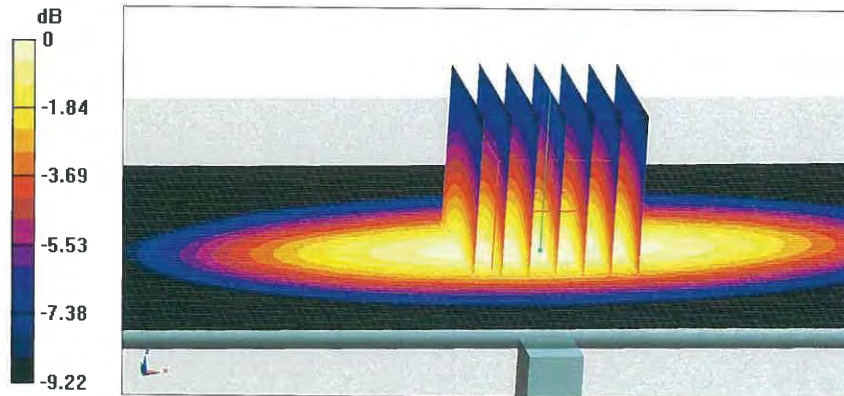

0 dB = 2.77 W/kg = 4.42 dBW/kg



In Collaboration with  
**s p e a g**  
CALIBRATION LABORATORY

Add: No.51 Xueyuan Road, Haidian District, Beijing, 100191, China  
Tel: +86-10-62304633-2079 Fax: +86-10-62304633-2504  
E-mail: cttl@chinattl.com http://www.chinattl.cn

### Impedance Measurement Plot for Body TSL

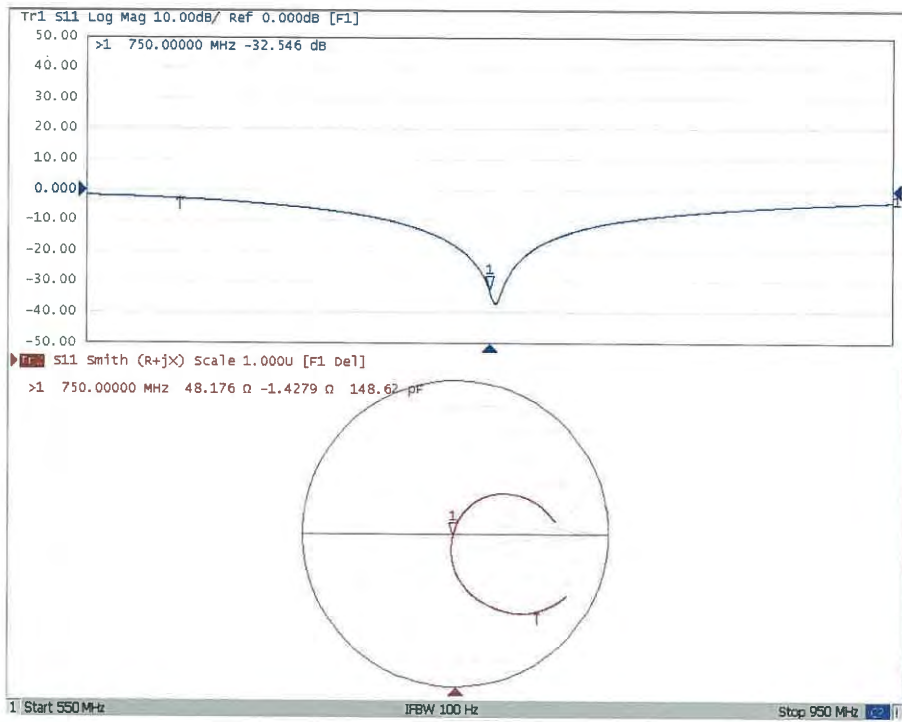



ST-039-18-246



In Collaboration with  
**s p e a g**  
CALIBRATION LABORATORY



中国认可  
国际互认  
校准  
CALIBRATION  
CNAS L0570

Add: No.51 Xueyuan Road, Haidian District, Beijing, 100191, China  
Tel: +86-10-62304633-2079 Fax: +86-10-62304633-2504  
E-mail: cttl@chinattl.com http://www.chinattl.cn

Client **ATL**

Certificate No: **Z18-60308**

## CALIBRATION CERTIFICATE

Object: D835V2 - SN: 4d082

Calibration Procedure(s): FF-Z11-003-01  
Calibration Procedures for dipole validation kits

Calibration date: September 6, 2018

This calibration Certificate documents the traceability to national standards, which realize the physical units of measurements(SI). The measurements and the uncertainties with confidence probability are given on the following pages and are part of the certificate.

All calibrations have been conducted in the closed laboratory facility: environment temperature(22±3)°C and humidity<70%.

Calibration Equipment used (M&TE critical for calibration)

Primary Standards	ID #	Cal Date(Calibrated by, Certificate No.)	Scheduled Calibration
Power Meter NRVD	102083	01-Nov-17 (CTTL, No.J17X08756)	Oct-18
Power sensor NRV-Z5	100542	01-Nov-17 (CTTL, No.J17X08756)	Oct-18
Reference Probe EX3DV4	SN 7464	12-Sep-17(SPEAG,No.EX3-7464_Sep17)	Sep-18
DAE4	SN 1524	13-Sep-17(SPEAG,No.DAE4-1524_Sep17)	Sep-18
Secondary Standards	ID #	Cal Date(Calibrated by, Certificate No.)	Scheduled Calibration
Signal Generator E4438C	MY49071430	23-Jan-18 (CTTL, No.J18X00560)	Jan-19
NetworkAnalyzer E5071C	MY46110673	24-Jan-18 (CTTL, No.J18X00561)	Jan-19

	Name	Function	Signature
Calibrated by:	Zhao Jing	SAR Test Engineer	
Reviewed by:	Lin Hao	SAR Test Engineer	
Approved by:	Qi Dianyuan	SAR Project Leader	

Issued: September 9, 2018

This calibration certificate shall not be reproduced except in full without written approval of the laboratory.

Certificate No: Z18-60308

Page 1 of 8

**Glossary:**

TSL	tissue simulating liquid
ConvF	sensitivity in TSL / NORM <sub>x,y,z</sub>
N/A	not applicable or not measured

**Calibration is Performed According to the Following Standards:**

- IEEE Std 1528-2013, "IEEE Recommended Practice for Determining the Peak Spatial-Averaged Specific Absorption Rate (SAR) in the Human Head from Wireless Communications Devices: Measurement Techniques", June 2013
- IEC 62209-1, "Measurement procedure for assessment of specific absorption rate of human exposure to radio frequency fields from hand-held and body-mounted wireless communication devices- Part 1: Device used next to the ear (Frequency range of 300MHz to 6GHz)", July 2016
- IEC 62209-2, "Procedure to measure the Specific Absorption Rate (SAR) For wireless communication devices used in close proximity to the human body (frequency range of 30MHz to 6GHz)", March 2010
- KDB865664, SAR Measurement Requirements for 100 MHz to 6 GHz

**Additional Documentation:**

- DASY4/5 System Handbook

**Methods Applied and Interpretation of Parameters:**

- Measurement Conditions:* Further details are available from the Validation Report at the end of the certificate. All figures stated in the certificate are valid at the frequency indicated.
- Antenna Parameters with TSL:* The dipole is mounted with the spacer to position its feed point exactly below the center marking of the flat phantom section, with the arms oriented parallel to the body axis.
- Feed Point Impedance and Return Loss:* These parameters are measured with the dipole positioned under the liquid filled phantom. The impedance stated is transformed from the measurement at the SMA connector to the feed point. The Return Loss ensures low reflected power. No uncertainty required.
- Electrical Delay:* One-way delay between the SMA connector and the antenna feed point. No uncertainty required.
- SAR measured:* SAR measured at the stated antenna input power.
- SAR normalized:* SAR as measured, normalized to an input power of 1 W at the antenna connector.
- SAR for nominal TSL parameters:* The measured TSL parameters are used to calculate the nominal SAR result.

The reported uncertainty of measurement is stated as the standard uncertainty of Measurement multiplied by the coverage factor  $k=2$ , which for a normal distribution corresponds to a coverage probability of approximately 95%.

### Measurement Conditions

DASY system configuration, as far as not given on page 1.

DASY Version	DASY52	52.10.1.1476
Extrapolation	Advanced Extrapolation	
Phantom	Triple Flat Phantom 5.1C	
Distance Dipole Center - TSL	15 mm	with Spacer
Zoom Scan Resolution	dx, dy, dz = 5 mm	
Frequency	835 MHz $\pm$ 1 MHz	

### Head TSL parameters

The following parameters and calculations were applied.

	Temperature	Permittivity	Conductivity
Nominal Head TSL parameters	22.0 °C	41.5	0.90 mho/m
Measured Head TSL parameters	(22.0 $\pm$ 0.2) °C	42.7 $\pm$ 6 %	0.90 mho/m $\pm$ 6 %
Head TSL temperature change during test	<1.0 °C	----	----

### SAR result with Head TSL

SAR averaged over 1 cm <sup>3</sup> (1 g) of Head TSL	Condition	
SAR measured	250 mW input power	2.32 mW / g
SAR for nominal Head TSL parameters	normalized to 1W	<b>9.31 mW / g <math>\pm</math> 18.8 % (k=2)</b>
SAR averaged over 10 cm <sup>3</sup> (10 g) of Head TSL	Condition	
SAR measured	250 mW input power	1.52 mW / g
SAR for nominal Head TSL parameters	normalized to 1W	<b>6.09 mW / g <math>\pm</math> 18.7 % (k=2)</b>

### Body TSL parameters

The following parameters and calculations were applied.

	Temperature	Permittivity	Conductivity
Nominal Body TSL parameters	22.0 °C	55.2	0.97 mho/m
Measured Body TSL parameters	(22.0 $\pm$ 0.2) °C	56.0 $\pm$ 6 %	1.00 mho/m $\pm$ 6 %
Body TSL temperature change during test	<1.0 °C	----	----

### SAR result with Body TSL

SAR averaged over 1 cm <sup>3</sup> (1 g) of Body TSL	Condition	
SAR measured	250 mW input power	2.46 mW / g
SAR for nominal Body TSL parameters	normalized to 1W	<b>9.66 mW / g <math>\pm</math> 18.8 % (k=2)</b>
SAR averaged over 10 cm <sup>3</sup> (10 g) of Body TSL	Condition	
SAR measured	250 mW input power	1.65 mW / g
SAR for nominal Body TSL parameters	normalized to 1W	<b>6.50 mW / g <math>\pm</math> 18.7 % (k=2)</b>



Add: No.51 Xueyuan Road, Haidian District, Beijing, 100191, China  
 Tel: +86-10-62304633-2079 Fax: +86-10-62304633-2504  
 E-mail: cttl@chinattl.com http://www.chinattl.cn

**Appendix (Additional assessments outside the scope of CNAS L0570)**

**Antenna Parameters with Head TSL**

Impedance, transformed to feed point	50.7Ω- 4.27jΩ
Return Loss	- 27.4dB

**Antenna Parameters with Body TSL**

Impedance, transformed to feed point	47.5Ω- 6.62jΩ
Return Loss	- 22.8dB

**General Antenna Parameters and Design**

Electrical Delay (one direction)	1.252 ns
----------------------------------	----------

After long term use with 100W radiated power, only a slight warming of the dipole near the feedpoint can be measured.

The dipole is made of standard semirigid coaxial cable. The center conductor of the feeding line is directly connected to the second arm of the dipole. The antenna is therefore short-circuited for DC-signals. On some of the dipoles, small end caps are added to the dipole arms in order to improve matching when loaded according to the position as explained in the "Measurement Conditions" paragraph. The SAR data are not affected by this change. The overall dipole length is still according to the Standard. No excessive force must be applied to the dipole arms, because they might bend or the soldered connections near the feedpoint may be damaged.

**Additional EUT Data**

Manufactured by	SPEAG
-----------------	-------

**DASY5 Validation Report for Head TSL**

Date: 09.04.2018

Test Laboratory: CTTL, Beijing, China

**DUT: Dipole 835 MHz; Type: D835V2; Serial: D835V2 - SN: 4d082**

Communication System: UID 0, CW; Frequency: 835 MHz; Duty Cycle: 1:1

Medium parameters used:  $f = 835 \text{ MHz}$ ;  $\sigma = 0.904 \text{ S/m}$ ;  $\epsilon_r = 42.71$ ;  $\rho = 1000 \text{ kg/m}^3$

Phantom section: Right Section

DASY5 Configuration:

- Probe: EX3DV4 - SN7464; ConvF(10.28, 10.28, 10.28) @ 835 MHz; Calibrated: 9/12/2017
- Sensor-Surface: 1.4mm (Mechanical Surface Detection)
- Electronics: DAE4 Sn1524; Calibrated: 9/13/2017
- Phantom: MFP\_V5.1C ; Type: QD 000 P51CA; Serial: 1062
- Measurement SW: DASY52, Version 52.10 (1); SEMCAD X Version 14.6.11 (7439)

**Dipole Calibration/Zoom Scan (7x7x7) (7x7x7)/Cube 0:** Measurement grid:  $dx=5\text{mm}$ ,  $dy=5\text{mm}$ ,  $dz=5\text{mm}$

Reference Value = 57.68 V/m; Power Drift = -0.07 dB

Peak SAR (extrapolated) = 3.52 W/kg

**SAR(1 g) = 2.32 W/kg; SAR(10 g) = 1.52 W/kg**

Maximum value of SAR (measured) = 3.11 W/kg

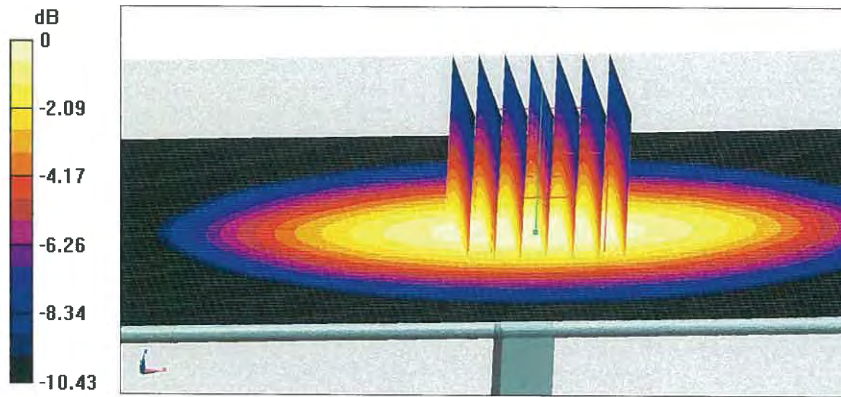

### Impedance Measurement Plot for Head TSL

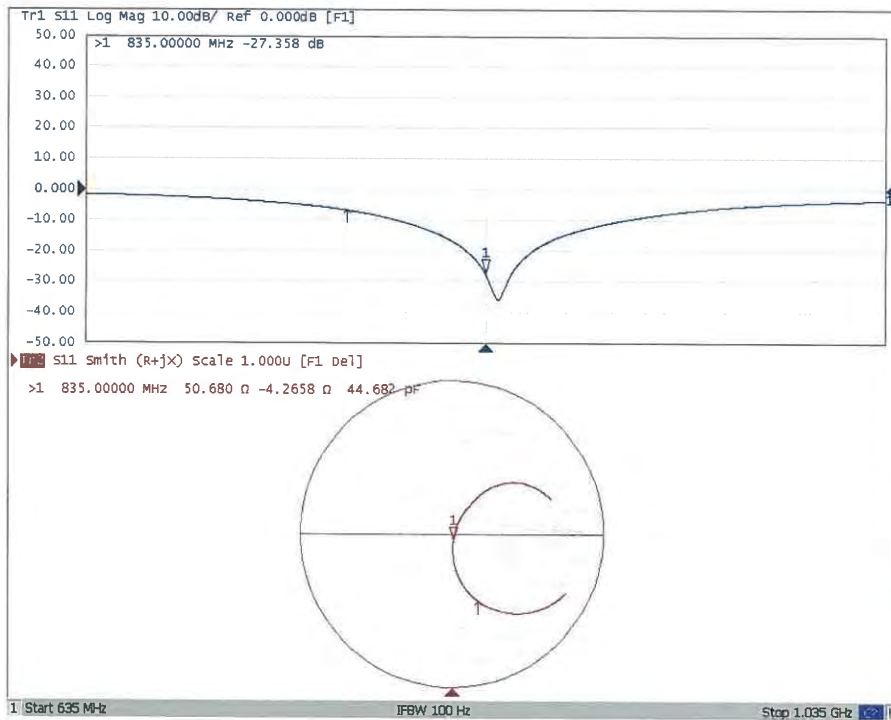



**DASY5 Validation Report for Body TSL**

Date: 09.06.2018

Test Laboratory: CTTL, Beijing, China

**DUT: Dipole 835 MHz; Type: D835V2; Serial: D835V2 - SN: 4d082**

Communication System: UID 0, CW; Frequency: 835 MHz; Duty Cycle: 1:1

Medium parameters used:  $f = 835$  MHz;  $\sigma = 0.998$  S/m;  $\epsilon_r = 56.04$ ;  $\rho = 1000$  kg/m<sup>3</sup>

Phantom section: Center Section

DASY5 Configuration:

- Probe: EX3DV4 - SN7464; ConvF(10.21, 10.21, 10.21) @ 835 MHz; Calibrated: 9/12/2017
- Sensor-Surface: 1.4mm (Mechanical Surface Detection)
- Electronics: DAE4 Sn1524; Calibrated: 9/13/2017
- Phantom: MFP\_V5.1C ; Type: QD 000 P51CA; Serial: 1062
- Measurement SW: DASY52, Version 52.10 (1); SEMCAD X Version 14.6.11 (7439)

**Dipole Calibration/Zoom Scan (7x7x7) (7x7x7)/Cube 0:** Measurement grid: dx=5mm, dy=5mm, dz=5mm

Reference Value = 56.02 V/m; Power Drift = -0.05 dB

Peak SAR (extrapolated) = 3.69 W/kg

**SAR(1 g) = 2.46 W/kg; SAR(10 g) = 1.65 W/kg**

Maximum value of SAR (measured) = 3.26 W/kg

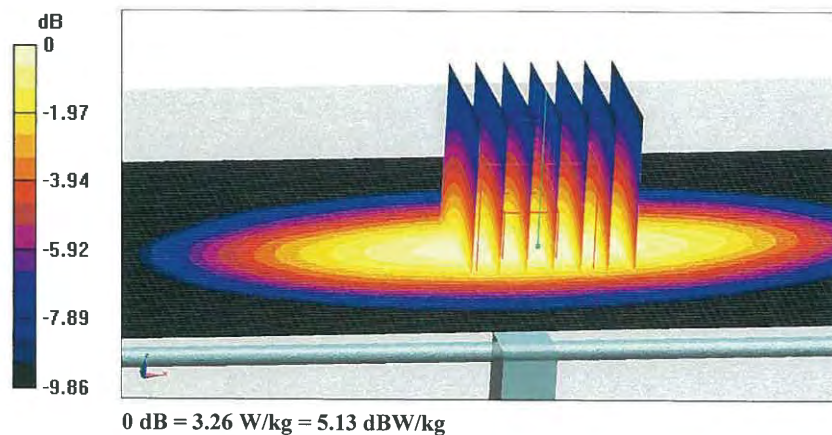

**Impedance Measurement Plot for Body TSL**

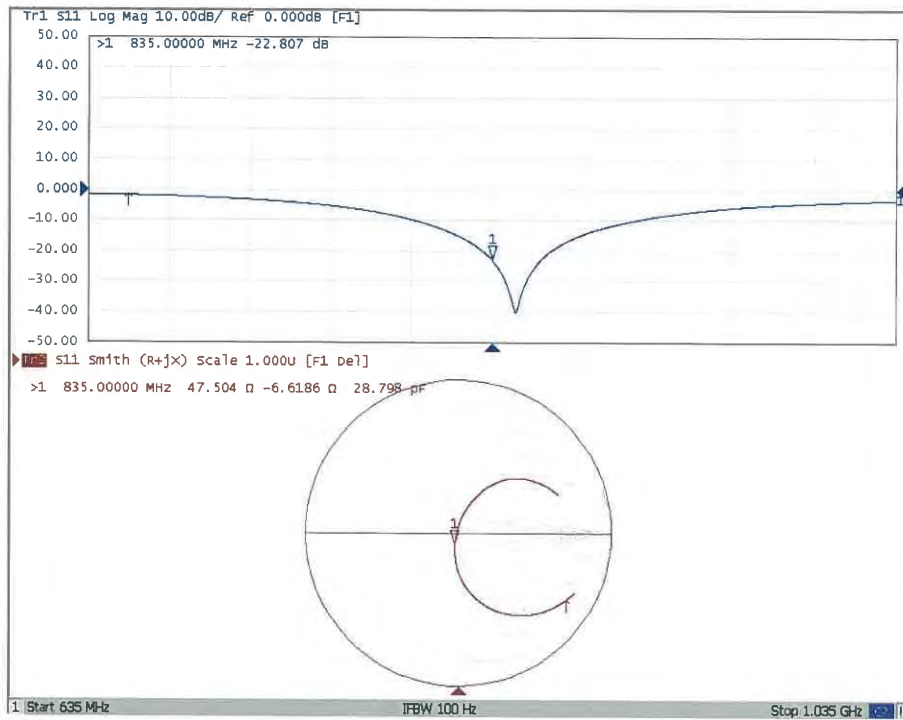

**Calibration Laboratory of  
Schmid & Partner  
Engineering AG**  
Zeughausstrasse 43, 8004 Zurich, Switzerland



**S** Schweizerischer Kalibrierdienst  
**C** Service suisse d'étalonnage  
**S** Servizio svizzero di taratura  
**S** Swiss Calibration Service

Accredited by the Swiss Accreditation Service (SAS)  
The Swiss Accreditation Service is one of the signatories to the EA  
Multilateral Agreement for the recognition of calibration certificates

Accreditation No.: **SCS 0108**

Client **Auden**

Certificate No: **D1750V2-1023\_Jun18**

## CALIBRATION CERTIFICATE

Object **D1750V2 - SN:1023**

Calibration procedure(s) **QA CAL-05.v10  
Calibration procedure for dipole validation kits above 700 MHz**

Calibration date: **June 11, 2018**

This calibration certificate documents the traceability to national standards, which realize the physical units of measurements (SI).  
The measurements and the uncertainties with confidence probability are given on the following pages and are part of the certificate.

All calibrations have been conducted in the closed laboratory facility: environment temperature (22 ± 3)°C and humidity < 70%.

Calibration Equipment used (M&TE critical for calibration)

Primary Standards	ID #	Cal Date (Certificate No.)	Scheduled Calibration
Power meter NRP	SN: 104778	04-Apr-18 (No. 217-02672/02673)	Apr-19
Power sensor NRP-Z91	SN: 103244	04-Apr-18 (No. 217-02672)	Apr-19
Power sensor NRP-Z91	SN: 103245	04-Apr-18 (No. 217-02673)	Apr-19
Reference 20 dB Attenuator	SN: 5058 (20k)	04-Apr-18 (No. 217-02682)	Apr-19
Type-N mismatch combination	SN: 5047.2 / 06327	04-Apr-18 (No. 217-02683)	Apr-19
Reference Probe EX3DV4	SN: 7349	30-Dec-17 (No. EX3-7349_Dec17)	Dec-18
DAE4	SN: 601	26-Oct-17 (No. DAE4-601_Oct17)	Oct-18
Secondary Standards	ID #	Check Date (in house)	Scheduled Check
Power meter EPM-442A	SN: GB37480704	07-Oct-15 (in house check Oct-16)	In house check: Oct-18
Power sensor HP 8481A	SN: US37292783	07-Oct-15 (in house check Oct-16)	In house check: Oct-18
Power sensor HP 8481A	SN: MY41092317	07-Oct-15 (in house check Oct-16)	In house check: Oct-18
RF generator R&S SMT-06	SN: 100972	15-Jun-15 (in house check Oct-16)	In house check: Oct-18
Network Analyzer HP 8753E	SN: US37390585	18-Oct-01 (in house check Oct-17)	In house check: Oct-18

Calibrated by: **Jeton Kastrati**      Name: **Jeton Kastrati**      Function: **Laboratory Technician**      Signature: 

Approved by: **Katja Pokovic**      Name: **Katja Pokovic**      Function: **Technical Manager**      Signature: 

Issued: June 11, 2018

This calibration certificate shall not be reproduced except in full without written approval of the laboratory.

**Calibration Laboratory of**  
Schmid & Partner  
Engineering AG  
Zeughausstrasse 43, 8004 Zurich, Switzerland



**S** Schweizerischer Kalibrierdienst  
**C** Service suisse d'étalonnage  
**S** Servizio svizzero di taratura  
**S** Swiss Calibration Service

Accredited by the Swiss Accreditation Service (SAS)  
The Swiss Accreditation Service is one of the signatories to the EA  
Multilateral Agreement for the recognition of calibration certificates

Accreditation No.: **SCS 0108**

**Glossary:**

TSL tissue simulating liquid  
ConvF sensitivity in TSL / NORM x,y,z  
N/A not applicable or not measured

**Calibration is Performed According to the Following Standards:**

- a) IEEE Std 1528-2013, "IEEE Recommended Practice for Determining the Peak Spatial-Averaged Specific Absorption Rate (SAR) in the Human Head from Wireless Communications Devices: Measurement Techniques", June 2013
- b) IEC 62209-1, "Measurement procedure for the assessment of Specific Absorption Rate (SAR) from hand-held and body-mounted devices used next to the ear (frequency range of 300 MHz to 6 GHz)", July 2016
- c) IEC 62209-2, "Procedure to determine the Specific Absorption Rate (SAR) for wireless communication devices used in close proximity to the human body (frequency range of 30 MHz to 6 GHz)", March 2010
- d) KDB 865664, "SAR Measurement Requirements for 100 MHz to 6 GHz"

**Additional Documentation:**

- e) DASY4/5 System Handbook

**Methods Applied and Interpretation of Parameters:**

- *Measurement Conditions:* Further details are available from the Validation Report at the end of the certificate. All figures stated in the certificate are valid at the frequency indicated.
- *Antenna Parameters with TSL:* The dipole is mounted with the spacer to position its feed point exactly below the center marking of the flat phantom section, with the arms oriented parallel to the body axis.
- *Feed Point Impedance and Return Loss:* These parameters are measured with the dipole positioned under the liquid filled phantom. The impedance stated is transformed from the measurement at the SMA connector to the feed point. The Return Loss ensures low reflected power. No uncertainty required.
- *Electrical Delay:* One-way delay between the SMA connector and the antenna feed point. No uncertainty required.
- *SAR measured:* SAR measured at the stated antenna input power.
- *SAR normalized:* SAR as measured, normalized to an input power of 1 W at the antenna connector.
- *SAR for nominal TSL parameters:* The measured TSL parameters are used to calculate the nominal SAR result.

The reported uncertainty of measurement is stated as the standard uncertainty of measurement multiplied by the coverage factor  $k=2$ , which for a normal distribution corresponds to a coverage probability of approximately 95%.



### Measurement Conditions

DASY system configuration, as far as not given on page 1.

DASY Version	DASY5	V52.10.1
Extrapolation	Advanced Extrapolation	
Phantom	Modular Flat Phantom	
Distance Dipole Center - TSL	10 mm	with Spacer
Zoom Scan Resolution	dx, dy, dz = 5 mm	
Frequency	1750 MHz $\pm$ 1 MHz	

### Head TSL parameters

The following parameters and calculations were applied.

	Temperature	Permittivity	Conductivity
Nominal Head TSL parameters	22.0 °C	40.1	1.37 mho/m
Measured Head TSL parameters	(22.0 $\pm$ 0.2) °C	39.0 $\pm$ 6 %	1.36 mho/m $\pm$ 6 %
Head TSL temperature change during test	< 0.5 °C	----	----

### SAR result with Head TSL

SAR averaged over 1 cm <sup>3</sup> (1 g) of Head TSL	Condition	
SAR measured	250 mW input power	9.10 W/kg
SAR for nominal Head TSL parameters	normalized to 1W	<b>36.3 W/kg <math>\pm</math> 17.0 % (k=2)</b>

SAR averaged over 10 cm <sup>3</sup> (10 g) of Head TSL	condition	
SAR measured	250 mW input power	4.82 W/kg
SAR for nominal Head TSL parameters	normalized to 1W	<b>19.3 W/kg <math>\pm</math> 16.5 % (k=2)</b>

### Body TSL parameters

The following parameters and calculations were applied.

	Temperature	Permittivity	Conductivity
Nominal Body TSL parameters	22.0 °C	53.4	1.49 mho/m
Measured Body TSL parameters	(22.0 $\pm$ 0.2) °C	53.6 $\pm$ 6 %	1.47 mho/m $\pm$ 6 %
Body TSL temperature change during test	< 0.5 °C	----	----

### SAR result with Body TSL

SAR averaged over 1 cm <sup>3</sup> (1 g) of Body TSL	Condition	
SAR measured	250 mW input power	9.12 W/kg
SAR for nominal Body TSL parameters	normalized to 1W	<b>36.8 W/kg <math>\pm</math> 17.0 % (k=2)</b>

SAR averaged over 10 cm <sup>3</sup> (10 g) of Body TSL	condition	
SAR measured	250 mW input power	4.90 W/kg
SAR for nominal Body TSL parameters	normalized to 1W	<b>19.7 W/kg <math>\pm</math> 16.5 % (k=2)</b>



## Appendix (Additional assessments outside the scope of SCS 0108)

### Antenna Parameters with Head TSL

Impedance, transformed to feed point	51.0 $\Omega$ - 0.5 $j\Omega$
Return Loss	- 39.1 dB

### Antenna Parameters with Body TSL

Impedance, transformed to feed point	46.0 $\Omega$ + 0.3 $j\Omega$
Return Loss	- 27.5 dB

### General Antenna Parameters and Design

Electrical Delay (one direction)	1.217 ns
----------------------------------	----------

After long term use with 100W radiated power, only a slight warming of the dipole near the feedpoint can be measured.

The dipole is made of standard semirigid coaxial cable. The center conductor of the feeding line is directly connected to the second arm of the dipole. The antenna is therefore short-circuited for DC-signals. On some of the dipoles, small end caps are added to the dipole arms in order to improve matching when loaded according to the position as explained in the "Measurement Conditions" paragraph. The SAR data are not affected by this change. The overall dipole length is still according to the Standard.

No excessive force must be applied to the dipole arms, because they might bend or the soldered connections near the feedpoint may be damaged.

### Additional EUT Data

Manufactured by	SPEAG
Manufactured on	August 20, 2009

## DASY5 Validation Report for Head TSL

Date: 11.06.2018

Test Laboratory: SPEAG, Zurich, Switzerland

**DUT: Dipole 1750 MHz; Type: D1750V2; Serial: D1750V2 - SN:1023**

Communication System: UID 0 - CW; Frequency: 1750 MHz

Medium parameters used:  $f = 1750$  MHz;  $\sigma = 1.36$  S/m;  $\epsilon_r = 39$ ;  $\rho = 1000$  kg/m<sup>3</sup>

Phantom section: Flat Section

Measurement Standard: DASY5 (IEEE/IEC/ANSI C63.19-2011)

DASY52 Configuration:

- Probe: EX3DV4 - SN7349; ConvF(8.5, 8.5, 8.5) @ 1750 MHz; Calibrated: 30.12.2017
- Sensor-Surface: 1.4mm (Mechanical Surface Detection)
- Electronics: DAE4 Sn601; Calibrated: 26.10.2017
- Phantom: Flat Phantom 5.0 (front); Type: QD 000 P50 AA; Serial: 1001
- DASY52 52.10.1(1476); SEMCAD X 14.6.11(7439)

### Dipole Calibration for Head Tissue/Pin=250 mW, d=10mm/Zoom Scan (7x7x7)/Cube 0:

Measurement grid: dx=5mm, dy=5mm, dz=5mm

Reference Value = 106.5 V/m; Power Drift = -0.05 dB

Peak SAR (extrapolated) = 16.5 W/kg

**SAR(1 g) = 9.1 W/kg; SAR(10 g) = 4.82 W/kg**

Maximum value of SAR (measured) = 14.0 W/kg

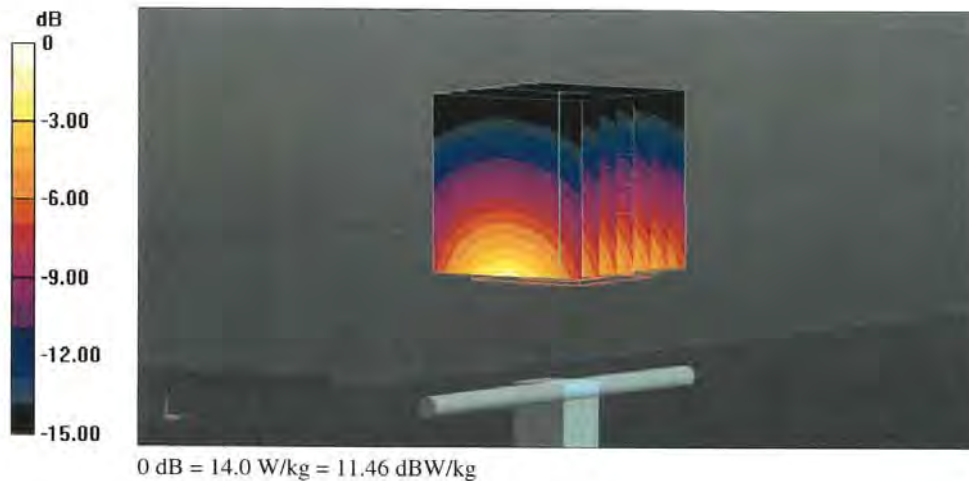



### Impedance Measurement Plot for Head TSL

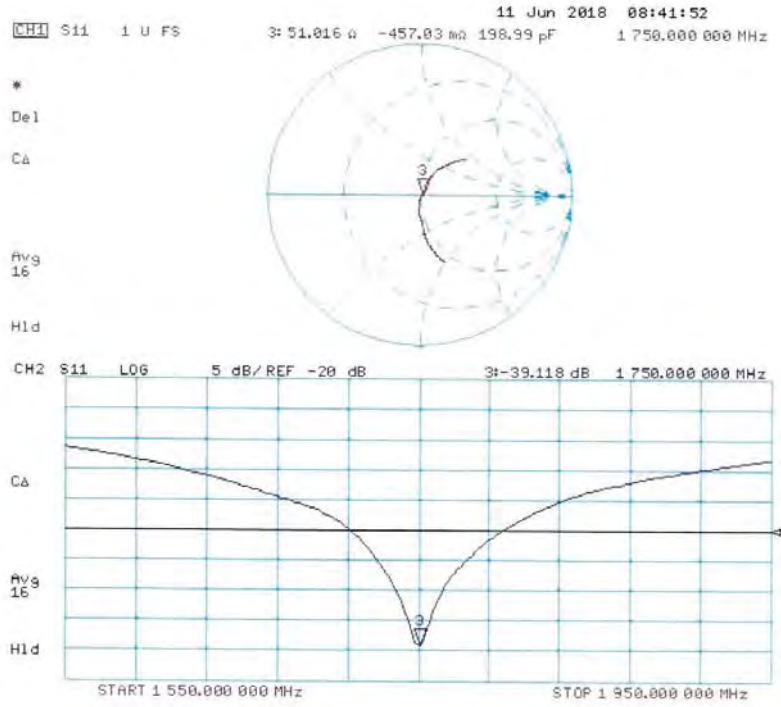



**DASY5 Validation Report for Body TSL**

Date: 11.06.2018

Test Laboratory: SPEAG, Zurich, Switzerland

**DUT: Dipole 1750 MHz; Type: D1750V2; Serial: D1750V2 - SN:1023**

Communication System: UID 0 - CW; Frequency: 1750 MHz  
 Medium parameters used:  $f = 1750$  MHz;  $\sigma = 1.47$  S/m;  $\epsilon_r = 53.6$ ;  $\rho = 1000$  kg/m<sup>3</sup>  
 Phantom section: Flat Section  
 Measurement Standard: DASY5 (IEEE/IEC/ANSI C63.19-2011)

DASY52 Configuration:

- Probe: EX3DV4 - SN7349; ConvF(8.35, 8.35, 8.35) @ 1750 MHz; Calibrated: 30.12.2017
- Sensor-Surface: 1.4mm (Mechanical Surface Detection)
- Electronics: DAE4 Sn601; Calibrated: 26.10.2017
- Phantom: Flat Phantom 5.0 (back); Type: QD 000 P50 AA; Serial: 1002
- DASY52 52.10.1(1476); SEMCAD X 14.6.11(7439)

**Dipole Calibration for Body Tissue/Pin=250 mW, d=10mm/Zoom Scan (7x7x7)/Cube 0:**

Measurement grid: dx=5mm, dy=5mm, dz=5mm  
 Reference Value = 102.3 V/m; Power Drift = -0.05 dB  
 Peak SAR (extrapolated) = 15.8 W/kg  
**SAR(1 g) = 9.12 W/kg; SAR(10 g) = 4.9 W/kg**  
 Maximum value of SAR (measured) = 13.5 W/kg

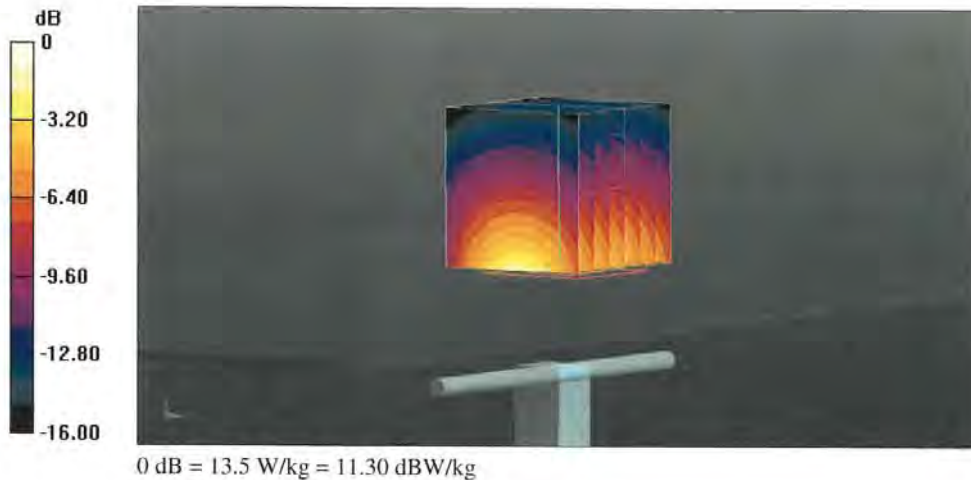



### Impedance Measurement Plot for Body TSL

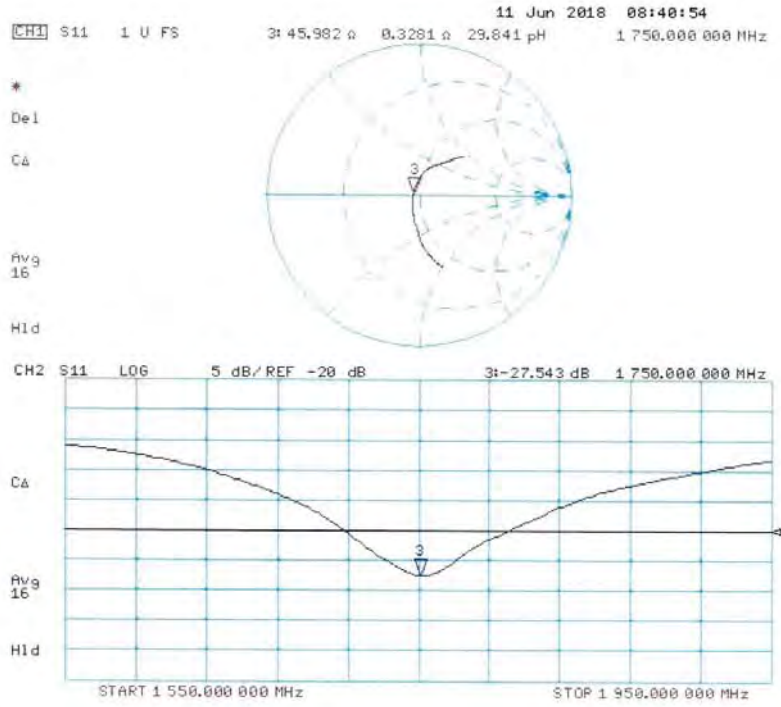



In Collaboration with  
**s p e a g**  
CALIBRATION LABORATORY



中国认可  
国际互认  
校准  
CALIBRATION  
CNAS L0570

ST-038-18-247

Add: No.51 Xueyuan Road, Haidian District, Beijing, 100191, China  
Tel: +86-10-62304633-2079 Fax: +86-10-62304633-2504  
E-mail: cttl@chinattl.com http://www.chinattl.cn

Client **ATL**

Certificate No: **Z18-60309**

## CALIBRATION CERTIFICATE

Object: D1900V2 - SN: 5d111

Calibration Procedure(s): FF-Z11-003-01  
Calibration Procedures for dipole validation kits

Calibration date: September 11, 2018

This calibration Certificate documents the traceability to national standards, which realize the physical units of measurements(SI). The measurements and the uncertainties with confidence probability are given on the following pages and are part of the certificate.

All calibrations have been conducted in the closed laboratory facility: environment temperature(22±3)°C and humidity<70%.

Calibration Equipment used (M&TE critical for calibration)

Primary Standards	ID #	Cal Date(Calibrated by, Certificate No.)	Scheduled Calibration
Power Meter NRVD	102083	01-Nov-17 (CTTL, No.J17X08756)	Oct-18
Power sensor NRV-Z5	100542	01-Nov-17 (CTTL, No.J17X08756)	Oct-18
Reference Probe EX3DV4	SN 7464	12-Sep-17(SPEAG,No.EX3-7464_Sep17)	Sep-18
DAE4	SN 1524	13-Sep-17(SPEAG,No.DAE4-1524_Sep17)	Sep-18
Secondary Standards	ID #	Cal Date(Calibrated by, Certificate No.)	Scheduled Calibration
Signal Generator E4438C	MY49071430	23-Jan-18 (CTTL, No.J18X00560)	Jan-19
NetworkAnalyzer E5071C	MY46110673	24-Jan-18 (CTTL, No.J18X00561)	Jan-19

	Name	Function	Signature
Calibrated by:	Zhao Jing	SAR Test Engineer	
Reviewed by:	Lin Jun	SAR Test Engineer	
Approved by:	Qi Dianyuan	SAR Project Leader	

Issued: September 15, 2018

This calibration certificate shall not be reproduced except in full without written approval of the laboratory.

**lossary:**

TSL	tissue simulating liquid
ConvF	sensitivity in TSL / NORM <sub>x,y,z</sub>
N/A	not applicable or not measured

**Calibration is Performed According to the Following Standards:**

- IEEE Std 1528-2013, "IEEE Recommended Practice for Determining the Peak Spatial-Averaged Specific Absorption Rate (SAR) in the Human Head from Wireless Communications Devices: Measurement Techniques", June 2013
- IEC 62209-1, "Measurement procedure for assessment of specific absorption rate of human exposure to radio frequency fields from hand-held and body-mounted wireless communication devices- Part 1: Device used next to the ear (Frequency range of 300MHz to 6GHz)", July 2016
- IEC 62209-2, "Procedure to measure the Specific Absorption Rate (SAR) For wireless communication devices used in close proximity to the human body (frequency range of 30MHz to 6GHz)", March 2010
- KDB865664, SAR Measurement Requirements for 100 MHz to 6 GHz

**Additional Documentation:**

- DASY4/5 System Handbook

**Methods Applied and Interpretation of Parameters:**

- Measurement Conditions:** Further details are available from the Validation Report at the end of the certificate. All figures stated in the certificate are valid at the frequency indicated.
- Antenna Parameters with TSL:** The dipole is mounted with the spacer to position its feed point exactly below the center marking of the flat phantom section, with the arms oriented parallel to the body axis.
- Feed Point Impedance and Return Loss:** These parameters are measured with the dipole positioned under the liquid filled phantom. The impedance stated is transformed from the measurement at the SMA connector to the feed point. The Return Loss ensures low reflected power. No uncertainty required.
- Electrical Delay:** One-way delay between the SMA connector and the antenna feed point. No uncertainty required.
- SAR measured:** SAR measured at the stated antenna input power.
- SAR normalized:** SAR as measured, normalized to an input power of 1 W at the antenna connector.
- SAR for nominal TSL parameters:** The measured TSL parameters are used to calculate the nominal SAR result.

The reported uncertainty of measurement is stated as the standard uncertainty of Measurement multiplied by the coverage factor  $k=2$ , which for a normal distribution Corresponds to a coverage probability of approximately 95%.

### Measurement Conditions

DASY system configuration, as far as not given on page 1.

DASY Version	DASY52	52.10.1.1476
Extrapolation	Advanced Extrapolation	
Phantom	Triple Flat Phantom 5.1C	
Distance Dipole Center - TSL	10 mm	with Spacer
Zoom Scan Resolution	dx, dy, dz = 5 mm	
Frequency	1900 MHz $\pm$ 1 MHz	

### Head TSL parameters

The following parameters and calculations were applied.

	Temperature	Permittivity	Conductivity
Nominal Head TSL parameters	22.0 °C	40.0	1.40 mho/m
Measured Head TSL parameters	(22.0 $\pm$ 0.2) °C	40.4 $\pm$ 6 %	1.44 mho/m $\pm$ 6 %
Head TSL temperature change during test	<1.0 °C	----	----

### SAR result with Head TSL

SAR averaged over 1 $cm^3$ (1 g) of Head TSL	Condition	
SAR measured	250 mW input power	10.1 mW / g
SAR for nominal Head TSL parameters	normalized to 1W	<b>39.8 mW / g <math>\pm</math> 18.8 % (k=2)</b>
SAR averaged over 10 $cm^3$ (10 g) of Head TSL	Condition	
SAR measured	250 mW input power	5.33 mW / g
SAR for nominal Head TSL parameters	normalized to 1W	<b>21.1 mW / g <math>\pm</math> 18.7 % (k=2)</b>

### Body TSL parameters

The following parameters and calculations were applied.

	Temperature	Permittivity	Conductivity
Nominal Body TSL parameters	22.0 °C	53.3	1.52 mho/m
Measured Body TSL parameters	(22.0 $\pm$ 0.2) °C	53.3 $\pm$ 6 %	1.49 mho/m $\pm$ 6 %
Body TSL temperature change during test	<1.0 °C	----	----

### SAR result with Body TSL

SAR averaged over 1 $cm^3$ (1 g) of Body TSL	Condition	
SAR measured	250 mW input power	9.99 mW / g
SAR for nominal Body TSL parameters	normalized to 1W	<b>40.4 mW / g <math>\pm</math> 18.8 % (k=2)</b>
SAR averaged over 10 $cm^3$ (10 g) of Body TSL	Condition	
SAR measured	250 mW input power	5.41 mW / g
SAR for nominal Body TSL parameters	normalized to 1W	<b>21.8 mW / g <math>\pm</math> 18.7 % (k=2)</b>

## Appendix (Additional assessments outside the scope of CNAS L0570)

### Antenna Parameters with Head TSL

Impedance, transformed to feed point	51.6Ω+ 6.78jΩ
Return Loss	- 23.3dB

### Antenna Parameters with Body TSL

Impedance, transformed to feed point	46.3Ω+ 6.22jΩ
Return Loss	- 22.5dB

### General Antenna Parameters and Design

Electrical Delay (one direction)	1.066 ns
----------------------------------	----------

After long term use with 100W radiated power, only a slight warming of the dipole near the feedpoint can be measured.

The dipole is made of standard semirigid coaxial cable. The center conductor of the feeding line is directly connected to the second arm of the dipole. The antenna is therefore short-circuited for DC-signals. On some of the dipoles, small end caps are added to the dipole arms in order to improve matching when loaded according to the position as explained in the "Measurement Conditions" paragraph. The SAR data are not affected by this change. The overall dipole length is still according to the Standard.

No excessive force must be applied to the dipole arms, because they might bend or the soldered connections near the feedpoint may be damaged.

### Additional EUT Data

Manufactured by	SPEAG
-----------------	-------

**DASY5 Validation Report for Head TSL**

Date: 09.10.2018

Test Laboratory: CTTL, Beijing, China

**DUT: Dipole 1900 MHz; Type: D1900V2; Serial: D1900V2 - SN: 5d111**

Communication System: UID 0, CW; Frequency: 1900 MHz; Duty Cycle: 1:1

Medium parameters used:  $f = 1900$  MHz;  $\sigma = 1.438$  S/m;  $\epsilon_r = 40.37$ ;  $\rho = 1000$  kg/m<sup>3</sup>

Phantom section: Center Section

DASY5 Configuration:

- Probe: EX3DV4 - SN7464; ConvF(8.39, 8.39, 8.39) @ 1900 MHz; Calibrated: 9/12/2017
- Sensor-Surface: 1.4mm (Mechanical Surface Detection)
- Electronics: DAE4 Sn1524; Calibrated: 9/13/2017
- Phantom: MFP\_V5.1C ; Type: QD 000 P51CA; Serial: 1062
- Measurement SW: DASY52, Version 52.10 (1); SEMCAD X Version 14.6.11 (7439)

**System Performance Check/Zoom Scan (7x7x7) (7x7x7)/Cube 0: Measurement grid:**

$dx=5$ mm,  $dy=5$ mm,  $dz=5$ mm

Reference Value = 95.90 V/m; Power Drift = -0.01 dB

Peak SAR (extrapolated) = 19.0 W/kg

**SAR(1 g) = 10.1 W/kg; SAR(10 g) = 5.33 W/kg**

Maximum value of SAR (measured) = 15.8 W/kg

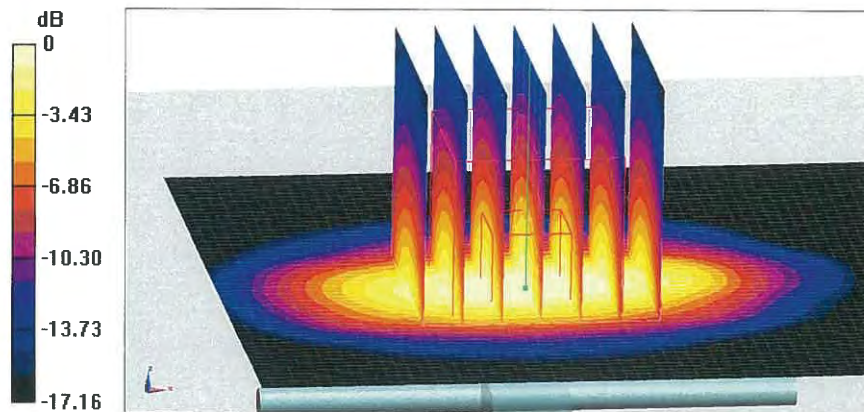

**0 dB = 15.8 W/kg = 11.99 dBW/kg**

### Impedance Measurement Plot for Head TSL

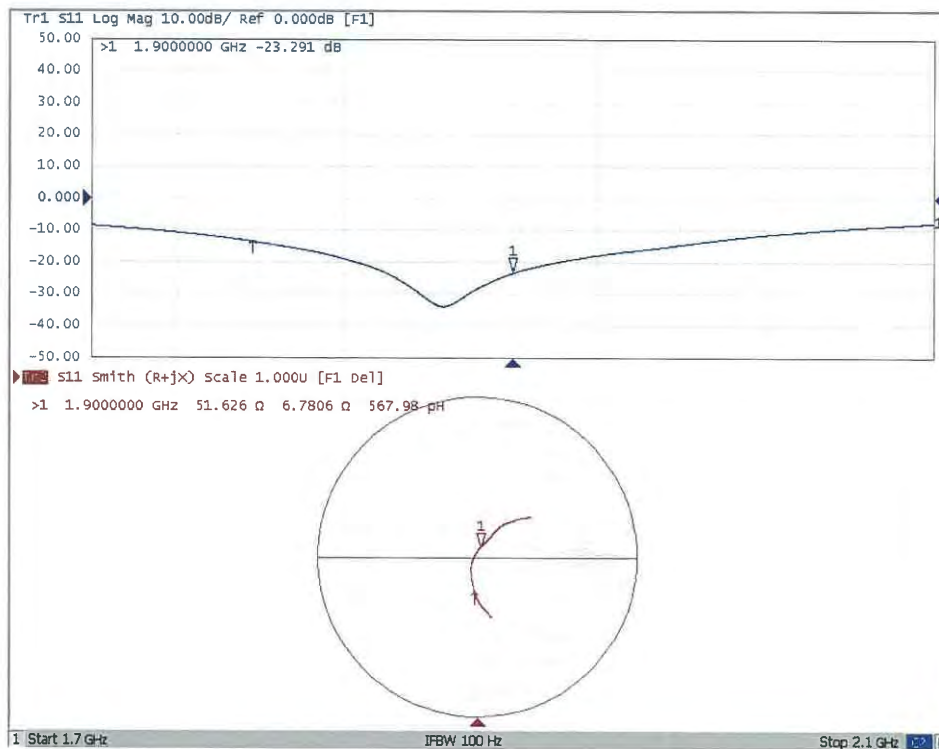



**DASY5 Validation Report for Body TSL**

Date: 09.10.2018

Test Laboratory: CTTL, Beijing, China

**DUT: Dipole 1900 MHz; Type: D1900V2; Serial: D1900V2 - SN: 5d111**

Communication System: UID 0, CW; Frequency: 1900 MHz; Duty Cycle: 1:1

Medium parameters used:  $f = 1900$  MHz;  $\sigma = 1.493$  S/m;  $\epsilon_r = 53.34$ ;  $\rho = 1000$  kg/m<sup>3</sup>

Phantom section: Right Section

DASY5 Configuration:

- Probe: EX3DV4 - SN7464; ConvF(8.32, 8.32, 8.32) @ 1900 MHz; Calibrated: 9/12/2017
- Sensor-Surface: 1.4mm (Mechanical Surface Detection)
- Electronics: DAE4 Sn1524; Calibrated: 9/13/2017
- Phantom: MFP\_V5.1C ; Type: QD 000 P51CA; Serial: 1062
- Measurement SW: DASY52, Version 52.10 (1); SEMCAD X Version 14.6.11 (7439)

**System Performance Check/Zoom Scan (7x7x7) (7x7x7)/Cube 0: Measurement grid:**

$dx=5$ mm,  $dy=5$ mm,  $dz=5$ mm

Reference Value = 96.64 V/m; Power Drift = -0.04 dB

Peak SAR (extrapolated) = 17.6 W/kg

**SAR(1 g) = 9.99 W/kg; SAR(10 g) = 5.41 W/kg**

Maximum value of SAR (measured) = 15.0 W/kg

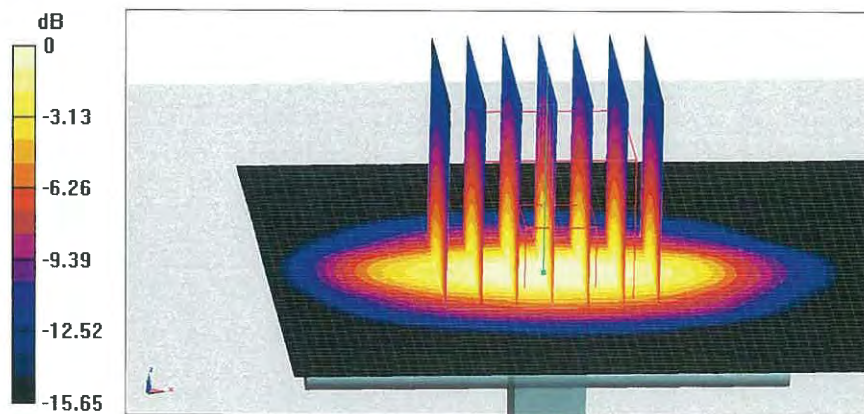

0 dB = 15.0 W/kg = 11.76 dBW/kg

### Impedance Measurement Plot for Body TSL

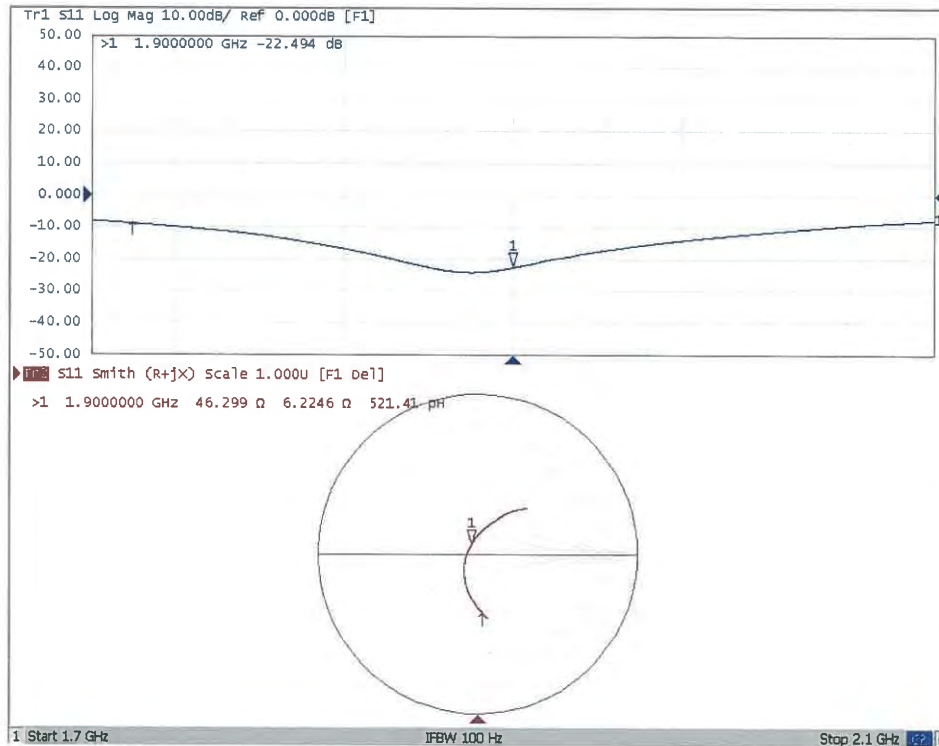

**Calibration Laboratory of  
Schmid & Partner  
Engineering AG**  
Zeughausstrasse 43, 8004 Zurich, Switzerland



**S** Schweizerischer Kalibrierdienst  
**C** Service suisse d'étalonnage  
**S** Servizio svizzero di taratura  
**S** Swiss Calibration Service

Accredited by the Swiss Accreditation Service (SAS)  
The Swiss Accreditation Service is one of the signatories to the EA  
Multilateral Agreement for the recognition of calibration certificates

Accreditation No.: **SCS 0108**

Client **Auden**

Certificate No: **D2450V2-735\_Dec18**

## CALIBRATION CERTIFICATE

Object **D2450V2 - SN:735**

Calibration procedure(s) **QA CAL-05.v10  
Calibration procedure for dipole validation kits above 700 MHz**

Calibration date: **December 11, 2018**

This calibration certificate documents the traceability to national standards, which realize the physical units of measurements (SI).  
The measurements and the uncertainties with confidence probability are given on the following pages and are part of the certificate.

All calibrations have been conducted in the closed laboratory facility: environment temperature ( $22 \pm 3$ )°C and humidity < 70%.

Calibration Equipment used (M&TE critical for calibration)

Primary Standards	ID #	Cal Date (Certificate No.)	Scheduled Calibration
Power meter NRP	SN: 104778	04-Apr-18 (No. 217-02672/02673)	Apr-19
Power sensor NRP-Z91	SN: 103244	04-Apr-18 (No. 217-02672)	Apr-19
Power sensor NRP-Z91	SN: 103245	04-Apr-18 (No. 217-02673)	Apr-19
Reference 20 dB Attenuator	SN: 5058 (20k)	04-Apr-18 (No. 217-02682)	Apr-19
Type-N mismatch combination	SN: 5047.2 / 06327	04-Apr-18 (No. 217-02683)	Apr-19
Reference Probe EX3DV4	SN: 7349	30-Dec-17 (No. EX3-7349_Dec17)	Dec-18
DAE4	SN: 601	04-Oct-18 (No. DAE4-601_Oct18)	Oct-19
Secondary Standards	ID #	Check Date (in house)	Scheduled Check
Power meter EPM-442A	SN: GB37480704	07-Oct-15 (in house check Oct-18)	In house check: Oct-20
Power sensor HP 8481A	SN: US37292783	07-Oct-15 (in house check Oct-18)	In house check: Oct-20
Power sensor HP 8481A	SN: MY41092317	07-Oct-15 (in house check Oct-18)	In house check: Oct-20
RF generator R&S SMT-06	SN: 100972	15-Jun-15 (in house check Oct-18)	In house check: Oct-20
Network Analyzer Agilent E8358A	SN: US41080477	31-Mar-14 (in house check Oct-18)	In house check: Oct-19

Calibrated by: **Name: Jeton Kastrati, Function: Laboratory Technician**

Approved by: **Name: Katja Pokovic, Function: Technical Manager**

Signature  
  

Issued: December 13, 2018

This calibration certificate shall not be reproduced except in full without written approval of the laboratory.

**Calibration Laboratory of**  
**Schmid & Partner**  
**Engineering AG**  
 Zeughausstrasse 43, 8004 Zurich, Switzerland



**S** Schweizerischer Kalibrierdienst  
**S** Service suisse d'étalonnage  
**C** Servizio svizzero di taratura  
**S** Swiss Calibration Service

Accredited by the Swiss Accreditation Service (SAS)  
 The Swiss Accreditation Service is one of the signatories to the EA  
 Multilateral Agreement for the recognition of calibration certificates

Accreditation No.: **SCS 0108**

**Glossary:**

TSL tissue simulating liquid  
 ConvF sensitivity in TSL / NORM x,y,z  
 N/A not applicable or not measured

**Calibration is Performed According to the Following Standards:**

- a) IEEE Std 1528-2013, "IEEE Recommended Practice for Determining the Peak Spatial-Averaged Specific Absorption Rate (SAR) in the Human Head from Wireless Communications Devices: Measurement Techniques", June 2013
- b) IEC 62209-1, "Measurement procedure for the assessment of Specific Absorption Rate (SAR) from hand-held and body-mounted devices used next to the ear (frequency range of 300 MHz to 6 GHz)", July 2016
- c) IEC 62209-2, "Procedure to determine the Specific Absorption Rate (SAR) for wireless communication devices used in close proximity to the human body (frequency range of 30 MHz to 6 GHz)", March 2010
- d) KDB 865664, "SAR Measurement Requirements for 100 MHz to 6 GHz"

**Additional Documentation:**

- e) DASY4/5 System Handbook

**Methods Applied and Interpretation of Parameters:**

- *Measurement Conditions:* Further details are available from the Validation Report at the end of the certificate. All figures stated in the certificate are valid at the frequency indicated.
- *Antenna Parameters with TSL:* The dipole is mounted with the spacer to position its feed point exactly below the center marking of the flat phantom section, with the arms oriented parallel to the body axis.
- *Feed Point Impedance and Return Loss:* These parameters are measured with the dipole positioned under the liquid filled phantom. The impedance stated is transformed from the measurement at the SMA connector to the feed point. The Return Loss ensures low reflected power. No uncertainty required.
- *Electrical Delay:* One-way delay between the SMA connector and the antenna feed point. No uncertainty required.
- *SAR measured:* SAR measured at the stated antenna input power.
- *SAR normalized:* SAR as measured, normalized to an input power of 1 W at the antenna connector.
- *SAR for nominal TSL parameters:* The measured TSL parameters are used to calculate the nominal SAR result.

The reported uncertainty of measurement is stated as the standard uncertainty of measurement multiplied by the coverage factor  $k=2$ , which for a normal distribution corresponds to a coverage probability of approximately 95%.

### Measurement Conditions

DASY system configuration, as far as not given on page 1.

DASY Version	DASY5	V52.10.2
Extrapolation	Advanced Extrapolation	
Phantom	Modular Flat Phantom	
Distance Dipole Center - TSL	10 mm	with Spacer
Zoom Scan Resolution	dx, dy, dz = 5 mm	
Frequency	2450 MHz $\pm$ 1 MHz	

### Head TSL parameters

The following parameters and calculations were applied.

	Temperature	Permittivity	Conductivity
Nominal Head TSL parameters	22.0 °C	39.2	1.80 mho/m
Measured Head TSL parameters	(22.0 $\pm$ 0.2) °C	37.8 $\pm$ 6 %	1.86 mho/m $\pm$ 6 %
Head TSL temperature change during test	< 0.5 °C	----	----

### SAR result with Head TSL

SAR averaged over 1 cm <sup>3</sup> (1 g) of Head TSL	Condition	
SAR measured	250 mW input power	13.4 W/kg
SAR for nominal Head TSL parameters	normalized to 1W	<b>52.3 W/kg <math>\pm</math> 17.0 % (k=2)</b>

SAR averaged over 10 cm <sup>3</sup> (10 g) of Head TSL	condition	
SAR measured	250 mW input power	6.19 W/kg
SAR for nominal Head TSL parameters	normalized to 1W	<b>24.4 W/kg <math>\pm</math> 16.5 % (k=2)</b>

### Body TSL parameters

The following parameters and calculations were applied.

	Temperature	Permittivity	Conductivity
Nominal Body TSL parameters	22.0 °C	52.7	1.95 mho/m
Measured Body TSL parameters	(22.0 $\pm$ 0.2) °C	51.0 $\pm$ 6 %	2.03 mho/m $\pm$ 6 %
Body TSL temperature change during test	< 0.5 °C	----	----

### SAR result with Body TSL

SAR averaged over 1 cm <sup>3</sup> (1 g) of Body TSL	Condition	
SAR measured	250 mW input power	12.9 W/kg
SAR for nominal Body TSL parameters	normalized to 1W	<b>50.2 W/kg <math>\pm</math> 17.0 % (k=2)</b>

SAR averaged over 10 cm <sup>3</sup> (10 g) of Body TSL	condition	
SAR measured	250 mW input power	6.01 W/kg
SAR for nominal Body TSL parameters	normalized to 1W	<b>23.7 W/kg <math>\pm</math> 16.5 % (k=2)</b>



## Appendix (Additional assessments outside the scope of SCS 0108)

### Antenna Parameters with Head TSL

Impedance, transformed to feed point	$55.3 \Omega + 5.7 j\Omega$
Return Loss	- 22.6 dB

### Antenna Parameters with Body TSL

Impedance, transformed to feed point	$50.5 \Omega + 6.5 j\Omega$
Return Loss	- 23.8 dB

### General Antenna Parameters and Design

Electrical Delay (one direction)	1.154 ns
----------------------------------	----------

After long term use with 100W radiated power, only a slight warming of the dipole near the feedpoint can be measured.

The dipole is made of standard semirigid coaxial cable. The center conductor of the feeding line is directly connected to the second arm of the dipole. The antenna is therefore short-circuited for DC-signals. On some of the dipoles, small end caps are added to the dipole arms in order to improve matching when loaded according to the position as explained in the "Measurement Conditions" paragraph. The SAR data are not affected by this change. The overall dipole length is still according to the Standard.

No excessive force must be applied to the dipole arms, because they might bend or the soldered connections near the feedpoint may be damaged.

### Additional EUT Data

Manufactured by	SPEAG
Manufactured on	May 07, 2003

## DASY5 Validation Report for Head TSL

Date: 11.12.2018

Test Laboratory: SPEAG, Zurich, Switzerland

**DUT: Dipole 2450 MHz; Type: D2450V2; Serial: D2450V2 - SN:735**

Communication System: UID 0 - CW; Frequency: 2450 MHz

Medium parameters used:  $f = 2450$  MHz;  $\sigma = 1.86$  S/m;  $\epsilon_r = 37.8$ ;  $\rho = 1000$  kg/m<sup>3</sup>

Phantom section: Flat Section

Measurement Standard: DASY5 (IEEE/IEC/ANSI C63.19-2011)

DASY52 Configuration:

- Probe: EX3DV4 - SN7349; ConvF(7.88, 7.88, 7.88) @ 2450 MHz; Calibrated: 30.12.2017
- Sensor-Surface: 1.4mm (Mechanical Surface Detection)
- Electronics: DAE4 Sn601; Calibrated: 04.10.2018
- Phantom: Flat Phantom 5.0 (front); Type: QD 000 P50 AA; Serial: 1001
- DASY52 52.10.2(1495); SEMCAD X 14.6.12(7450)

### Dipole Calibration for Head Tissue/Pin=250 mW, d=10mm/Zoom Scan (7x7x7)/Cube 0:

Measurement grid: dx=5mm, dy=5mm, dz=5mm

Reference Value = 117.4 V/m; Power Drift = -0.04 dB

Peak SAR (extrapolated) = 27.2 W/kg

**SAR(1 g) = 13.4 W/kg; SAR(10 g) = 6.19 W/kg**

Maximum value of SAR (measured) = 22.4 W/kg

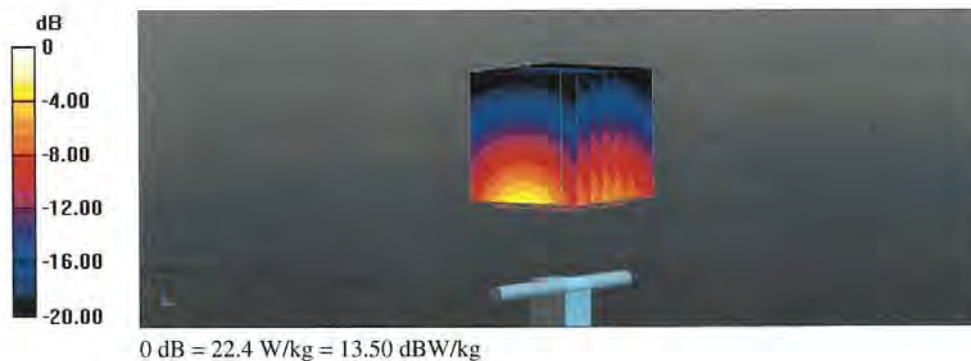



### Impedance Measurement Plot for Head TSL

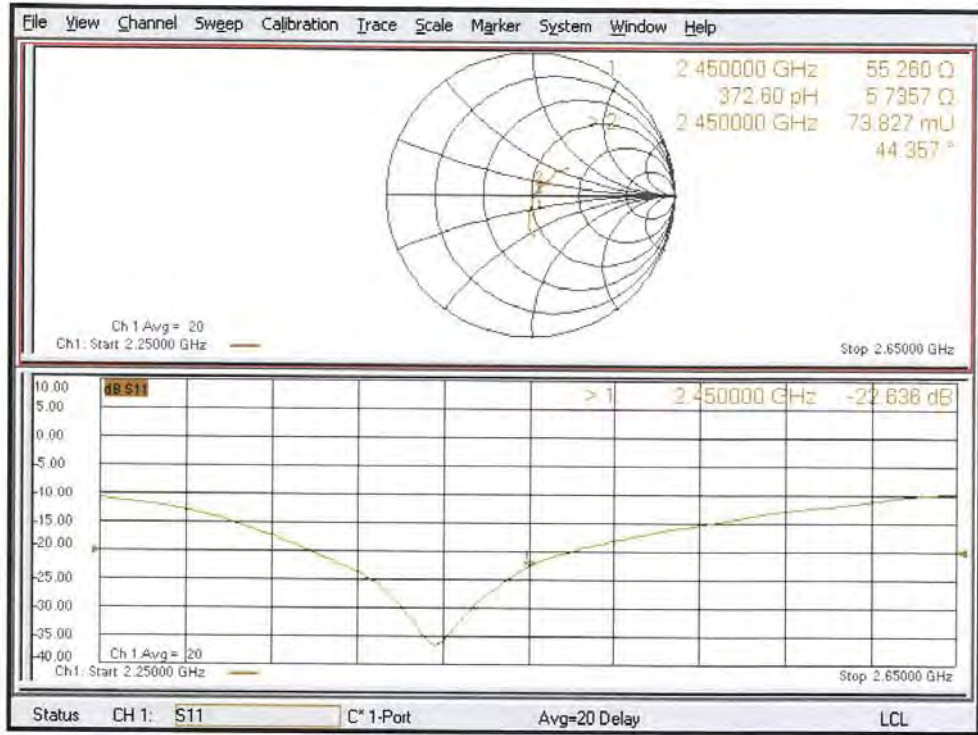



## DASY5 Validation Report for Body TSL

Date: 11.12.2018

Test Laboratory: SPEAG, Zurich, Switzerland

**DUT: Dipole 2450 MHz; Type: D2450V2; Serial: D2450V2 - SN:735**

Communication System: UID 0 - CW; Frequency: 2450 MHz

Medium parameters used:  $f = 2450$  MHz;  $\sigma = 2.03$  S/m;  $\epsilon_r = 51$ ;  $\rho = 1000$  kg/m<sup>3</sup>

Phantom section: Flat Section

Measurement Standard: DASY5 (IEEE/IEC/ANSI C63.19-2011)

DASY52 Configuration:

- Probe: EX3DV4 - SN7349; ConvF(8.01, 8.01, 8.01) @ 2450 MHz; Calibrated: 30.12.2017
- Sensor-Surface: 1.4mm (Mechanical Surface Detection)
- Electronics: DAE4 Sn601; Calibrated: 04.10.2018
- Phantom: Flat Phantom 5.0 (back); Type: QD 000 P50 AA; Serial: 1002
- DASY52 52.10.2(1495); SEMCAD X 14.6.12(7450)

### Dipole Calibration for Body Tissue/Pin=250 mW, d=10mm/Zoom Scan (7x7x7)/Cube 0:

Measurement grid: dx=5mm, dy=5mm, dz=5mm

Reference Value = 107.2 V/m; Power Drift = -0.03 dB

Peak SAR (extrapolated) = 25.8 W/kg

**SAR(1 g) = 12.9 W/kg; SAR(10 g) = 6.01 W/kg**

Maximum value of SAR (measured) = 21.0 W/kg





### Impedance Measurement Plot for Body TSL

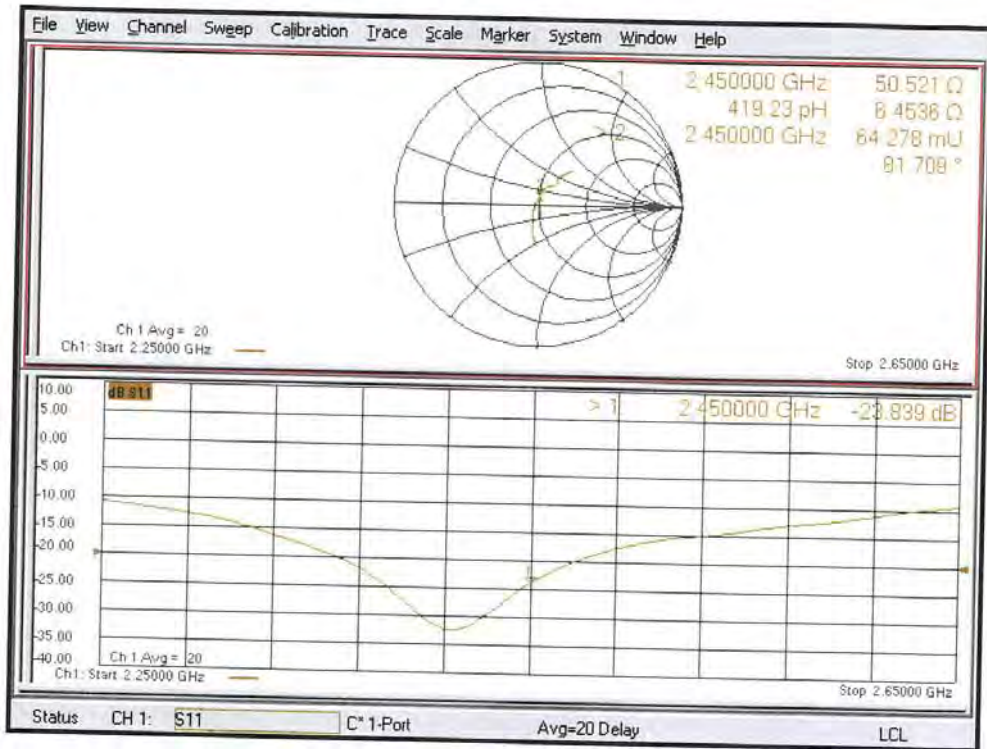



中国认可  
国际互认  
校准  
CALIBRATION  
CNAS L0570

ST-001-19-084

Add: No.51 Xueyuan Road, Haidian District, Beijing, 100191, China  
Tel: +86-10-62304633-2512 Fax: +86-10-62304633-2504  
E-mail: cttl@chinattl.com http://www.chinattl.cn

Client **ATL**

Certificate No: **Z19-60131**

## CALIBRATION CERTIFICATE

Object: D5GHzV2 - SN: 1021

Calibration Procedure(s): FF-Z11-003-01  
Calibration Procedures for dipole validation kits

Calibration date: April 19, 2019

This calibration Certificate documents the traceability to national standards, which realize the physical units of measurements(SI). The measurements and the uncertainties with confidence probability are given on the following pages and are part of the certificate.

All calibrations have been conducted in the closed laboratory facility: environment temperature(22±3)°C and humidity<70%.

Calibration Equipment used (M&TE critical for calibration)

Primary Standards	ID #	Cal Date(Calibrated by, Certificate No.)	Scheduled Calibration
Power Meter NRP2	106277	20-Aug-18 (CTTL, No.J18X06862)	Aug-19
Power sensor NRP8S	104291	20-Aug-18 (CTTL, No.J18X06862)	Aug-19
ReferenceProbe EX3DV4	SN 7514	27-Aug-18(SPEAG,No.EX3-7514_Aug18/2)	Aug-19
DAE4	SN 1331	06-Feb-19(SPEAG,No.DAE4-1331_Feb19)	Feb-20
Secondary Standards	ID #	Cal Date(Calibrated by, Certificate No.)	Scheduled Calibration
Signal Generator E4438C	MY49071430	23-Jan-19 (CTTL, No.J19X00336)	Jan-20
NetworkAnalyzerE5071C	MY46110673	24-Jan-19 (CTTL, No.J19X00547)	Jan-20

	Name	Function	Signature
Calibrated by:	Zhao Jing	SAR Test Engineer	
Reviewed by:	Lin Hao	SAR Test Engineer	
Approved by:	Qi Dianyuan	SAR Project Leader	

Issued: April 25, 2019

This calibration certificate shall not be reproduced except in full without written approval of the laboratory.

**Glossary:**

TSL	tissue simulating liquid
ConvF	sensitivity in TSL / NORM <sub>x,y,z</sub>
N/A	not applicable or not measured

**Calibration is Performed According to the Following Standards:**

- IEEE Std 1528-2013, "IEEE Recommended Practice for Determining the Peak Spatial-Averaged Specific Absorption Rate (SAR) in the Human Head from Wireless Communications Devices: Measurement Techniques", June 2013
- IEC 62209-1, "Measurement procedure for assessment of specific absorption rate of human exposure to radio frequency fields from hand-held and body-mounted wireless communication devices- Part 1: Device used next to the ear (Frequency range of 300MHz to 6GHz)", July 2016
- IEC 62209-2, "Procedure to measure the Specific Absorption Rate (SAR) For wireless communication devices used in close proximity to the human body (frequency range of 30MHz to 6GHz)", March 2010
- KDB865664, SAR Measurement Requirements for 100 MHz to 6 GHz

**Additional Documentation:**

- DASY4/5 System Handbook

**Methods Applied and Interpretation of Parameters:**

- Measurement Conditions:* Further details are available from the Validation Report at the end of the certificate. All figures stated in the certificate are valid at the frequency indicated.
- Antenna Parameters with TSL:* The dipole is mounted with the spacer to position its feed point exactly below the center marking of the flat phantom section, with the arms oriented parallel to the body axis.
- Feed Point Impedance and Return Loss:* These parameters are measured with the dipole positioned under the liquid filled phantom. The impedance stated is transformed from the measurement at the SMA connector to the feed point. The Return Loss ensures low reflected power. No uncertainty required.
- Electrical Delay:* One-way delay between the SMA connector and the antenna feed point. No uncertainty required.
- SAR measured:* SAR measured at the stated antenna input power.
- SAR normalized:* SAR as measured, normalized to an input power of 1 W at the antenna connector.
- SAR for nominal TSL parameters:* The measured TSL parameters are used to calculate the nominal SAR result.

The reported uncertainty of measurement is stated as the standard uncertainty of Measurement multiplied by the coverage factor  $k=2$ , which for a normal distribution Corresponds to a coverage probability of approximately 95%.

### Measurement Conditions

DASY system configuration, as far as not given on page 1.

DASY Version	DASY52	52.10.2.1495
Extrapolation	Advanced Extrapolation	
Phantom	Triple Flat Phantom 5.1C	
Distance Dipole Center - TSL	10 mm	with Spacer
Zoom Scan Resolution	dx, dy = 4 mm, dz = 1.4 mm	Graded Ratio = 1.4 (Z direction)
Frequency	5250 MHz ± 1 MHz 5600 MHz ± 1 MHz 5750 MHz ± 1 MHz	

### Head TSL parameters at 5250 MHz

The following parameters and calculations were applied.

	Temperature	Permittivity	Conductivity
Nominal Head TSL parameters	22.0 °C	35.9	4.71 mho/m
Measured Head TSL parameters	(22.0 ± 0.2) °C	34.9 ± 6 %	4.58 mho/m ± 6 %
Head TSL temperature change during test	<1.0 °C	----	----

### SAR result with Head TSL at 5250 MHz

SAR averaged over 1 cm <sup>3</sup> (1 g) of Head TSL	Condition	
SAR measured	100 mW input power	7.66 W/kg
SAR for nominal Head TSL parameters	normalized to 1W	<b>76.1 W/kg ± 24.4 % (k=2)</b>
SAR averaged over 10 cm <sup>3</sup> (10 g) of Head TSL	Condition	
SAR measured	100 mW input power	2.18 W/kg
SAR for nominal Head TSL parameters	normalized to 1W	<b>21.6 W/kg ± 24.2 % (k=2)</b>

### Head TSL parameters at 5600 MHz

The following parameters and calculations were applied.

	Temperature	Permittivity	Conductivity
Nominal Head TSL parameters	22.0 °C	35.5	5.07 mho/m
Measured Head TSL parameters	(22.0 ± 0.2) °C	34.5 ± 6 %	4.92 mho/m ± 6 %
Head TSL temperature change during test	<1.0 °C	----	----

### SAR result with Head TSL at 5600 MHz

SAR averaged over 1 cm <sup>3</sup> (1 g) of Head TSL	Condition	
SAR measured	100 mW input power	8.16 W/kg
SAR for nominal Head TSL parameters	normalized to 1W	<b>81.0 W/kg ± 24.4 % (k=2)</b>
SAR averaged over 10 cm <sup>3</sup> (10 g) of Head TSL	Condition	
SAR measured	100 mW input power	2.29 W/kg
SAR for nominal Head TSL parameters	normalized to 1W	<b>22.7 W/kg ± 24.2 % (k=2)</b>

### Head TSL parameters at 5750 MHz

The following parameters and calculations were applied.

	Temperature	Permittivity	Conductivity
Nominal Head TSL parameters	22.0 °C	35.4	5.22 mho/m
Measured Head TSL parameters	(22.0 ± 0.2) °C	34.4 ± 6 %	5.07 mho/m ± 6 %
Head TSL temperature change during test	<1.0 °C	----	----

### SAR result with Head TSL at 5750 MHz

SAR averaged over 1 cm <sup>3</sup> (1 g) of Head TSL	Condition	
SAR measured	100 mW input power	7.66 W/kg
SAR for nominal Head TSL parameters	normalized to 1W	<b>76.1 W/kg ± 24.4 % (k=2)</b>
SAR averaged over 10 cm <sup>3</sup> (10 g) of Head TSL	Condition	
SAR measured	100 mW input power	2.15 W/kg
SAR for nominal Head TSL parameters	normalized to 1W	<b>21.3 W/kg ± 24.2 % (k=2)</b>

### Body TSL parameters at 5250 MHz

The following parameters and calculations were applied.

	Temperature	Permittivity	Conductivity
<b>Nominal Body TSL parameters</b>	22.0 °C	48.9	5.36 mho/m
<b>Measured Body TSL parameters</b>	(22.0 ± 0.2) °C	50.3 ± 6 %	5.49 mho/m ± 6 %
<b>Body TSL temperature change during test</b>	<1.0 °C	----	----

### SAR result with Body TSL at 5250 MHz

<b>SAR averaged over 1 cm<sup>3</sup> (1 g) of Body TSL</b>	Condition	
SAR measured	100 mW input power	7.39 W/kg
SAR for nominal Body TSL parameters	normalized to 1W	<b>74.4 W/kg ± 24.4 % (k=2)</b>
<b>SAR averaged over 10 cm<sup>3</sup> (10 g) of Body TSL</b>	Condition	
SAR measured	100 mW input power	2.09 W/kg
SAR for nominal Body TSL parameters	normalized to 1W	<b>21.1 W/kg ± 24.2 % (k=2)</b>

### Body TSL parameters at 5600 MHz

The following parameters and calculations were applied.

	Temperature	Permittivity	Conductivity
<b>Nominal Body TSL parameters</b>	22.0 °C	48.5	5.77 mho/m
<b>Measured Body TSL parameters</b>	(22.0 ± 0.2) °C	49.9 ± 6 %	5.94 mho/m ± 6 %
<b>Body TSL temperature change during test</b>	<1.0 °C	----	----

### SAR result with Body TSL at 5600 MHz

<b>SAR averaged over 1 cm<sup>3</sup> (1 g) of Body TSL</b>	Condition	
SAR measured	100 mW input power	7.65 W/kg
SAR for nominal Body TSL parameters	normalized to 1W	<b>77.0 W/kg ± 24.4 % (k=2)</b>
<b>SAR averaged over 10 cm<sup>3</sup> (10 g) of Body TSL</b>	Condition	
SAR measured	100 mW input power	2.16 W/kg
SAR for nominal Body TSL parameters	normalized to 1W	<b>21.8 W/kg ± 24.2 % (k=2)</b>

### Body TSL parameters at 5750 MHz

The following parameters and calculations were applied.

	Temperature	Permittivity	Conductivity
Nominal Body TSL parameters	22.0 °C	48.3	5.94 mho/m
Measured Body TSL parameters	(22.0 ± 0.2) °C	49.7 ± 6 %	6.11 mho/m ± 6 %
Body TSL temperature change during test	<1.0 °C	----	----

### SAR result with Body TSL at 5750 MHz

SAR averaged over 1 cm <sup>3</sup> (1 g) of Body TSL	Condition	
SAR measured	100 mW input power	7.41 W/kg
SAR for nominal Body TSL parameters	normalized to 1W	<b>74.6 W/kg ± 24.4 % (k=2)</b>
SAR averaged over 10 cm <sup>3</sup> (10 g) of Body TSL	Condition	
SAR measured	100 mW input power	2.08 W/kg
SAR for nominal Body TSL parameters	normalized to 1W	<b>21.0 W/kg ± 24.2 % (k=2)</b>



**Appendix (Additional assessments outside the scope of CNAS L0570)**

**Antenna Parameters with Head TSL at 5250 MHz**

Impedance, transformed to feed point	51.9Ω - 4.22jΩ
Return Loss	- 26.9dB

**Antenna Parameters with Head TSL at 5600 MHz**

Impedance, transformed to feed point	58.4Ω - 0.27jΩ
Return Loss	- 22.2dB

**Antenna Parameters with Head TSL at 5750 MHz**

Impedance, transformed to feed point	56.7Ω + 1.19jΩ
Return Loss	- 23.9dB

**Antenna Parameters with Body TSL at 5250 MHz**

Impedance, transformed to feed point	52.3Ω - 2.82jΩ
Return Loss	- 28.9dB

**Antenna Parameters with Body TSL at 5600 MHz**

Impedance, transformed to feed point	58.7Ω + 1.14jΩ
Return Loss	- 21.8dB

**Antenna Parameters with Body TSL at 5750 MHz**

Impedance, transformed to feed point	57.5Ω + 1.49jΩ
Return Loss	- 23.0dB



Add: No.51 Xueyuan Road, Haidian District, Beijing, 100191, China  
Tel: +86-10-62304633-2512 Fax: +86-10-62304633-2504  
E-mail: cttl@chinattl.com http://www.chinattl.cn

### General Antenna Parameters and Design

Electrical Delay (one direction)	1.064 ns
----------------------------------	----------

After long term use with 100W radiated power, only a slight warming of the dipole near the feedpoint can be measured.

The dipole is made of standard semirigid coaxial cable. The center conductor of the feeding line is directly connected to the second arm of the dipole. The antenna is therefore short-circuited for DC-signals. On some of the dipoles, small end caps are added to the dipole arms in order to improve matching when loaded according to the position as explained in the "Measurement Conditions" paragraph. The SAR data are not affected by this change. The overall dipole length is still according to the Standard. No excessive force must be applied to the dipole arms, because they might bend or the soldered connections near the feedpoint may be damaged.

### Additional EUT Data

Manufactured by	SPEAG
-----------------	-------



Add: No.51 Xueyuan Road, Haidian District, Beijing, 100191, China  
Tel: +86-10-62304633-2512 Fax: +86-10-62304633-2504  
E-mail: cttl@chinattl.com http://www.chinattl.cn

**DASY5 Validation Report for Head TSL**

Date: 04.17.2019

Test Laboratory: CTTL, Beijing, China

**DUT: Dipole 5GHz; Type: D5GHzV2; Serial: D5GHzV2 - SN: 1021**

Communication System: CW; Frequency: 5250 MHz, Frequency: 5600 MHz,  
Frequency: 5750 MHz,

Medium parameters used:  $f = 5250$  MHz;  $\sigma = 4.576$  S/m;  $\epsilon_r = 34.9$ ;  $\rho = 1000$  kg/m<sup>3</sup>,  
Medium parameters used:  $f = 5600$  MHz;  $\sigma = 4.923$  S/m;  $\epsilon_r = 34.46$ ;  $\rho = 1000$   
kg/m<sup>3</sup>, Medium parameters used:  $f = 5750$  MHz;  $\sigma = 5.066$  S/m;  $\epsilon_r = 34.4$ ;  $\rho =$   
1000 kg/m<sup>3</sup>,

Phantom section: Center Section

DASY5 Configuration:

- Probe: EX3DV4 - SN7514; ConvF(5.02, 5.02, 5.02) @ 5250 MHz; Calibrated: 8/27/2018, ConvF(4.41, 4.41, 4.41) @ 5600 MHz; Calibrated: 8/27/2018, ConvF(4.47, 4.47, 4.47) @ 5750 MHz; Calibrated: 8/27/2018,
- Sensor-Surface: 1.4mm (Mechanical Surface Detection)
- Electronics: DAE4 Sn1331; Calibrated: 2/6/2019
- Phantom: MFP\_V5.1C ; Type: QD 000 P51CA; Serial: 1062
- Measurement SW: DASY52, Version 52.10 (2); SEMCAD X Version 14.6.12 (7450)

**Dipole Calibration /Pin=100mW, d=10mm, f=5250 MHz/Zoom Scan,**

**dist=1.4mm (8x8x7)/Cube 0:** Measurement grid: dx=4mm, dy=4mm, dz=1.4mm

Reference Value = 70.41 V/m; Power Drift = -0.01 dB

Peak SAR (extrapolated) = 33.3 W/kg

**SAR(1 g) = 7.66 W/kg; SAR(10 g) = 2.18 W/kg**

Maximum value of SAR (measured) = 18.1 W/kg

**Dipole Calibration /Pin=100mW, d=10mm, f=5600 MHz/Zoom Scan,**

**dist=1.4mm (8x8x7)/Cube 0:** Measurement grid: dx=4mm, dy=4mm, dz=1.4mm

Reference Value = 61.17 V/m; Power Drift = 0.00 dB

Peak SAR (extrapolated) = 38.8 W/kg

**SAR(1 g) = 8.16 W/kg; SAR(10 g) = 2.29 W/kg**

Maximum value of SAR (measured) = 21.0 W/kg

**Dipole Calibration /Pin=100mW, d=10mm, f=5750 MHz/Zoom Scan,**

**dist=1.4mm (8x8x7)/Cube 0:** Measurement grid: dx=4mm, dy=4mm, dz=1.4mm

Reference Value = 63.86 V/m; Power Drift = 0.03 dB

Peak SAR (extrapolated) = 38.0 W/kg

**SAR(1 g) = 7.66 W/kg; SAR(10 g) = 2.15 W/kg**

Maximum value of SAR (measured) = 19.2 W/kg

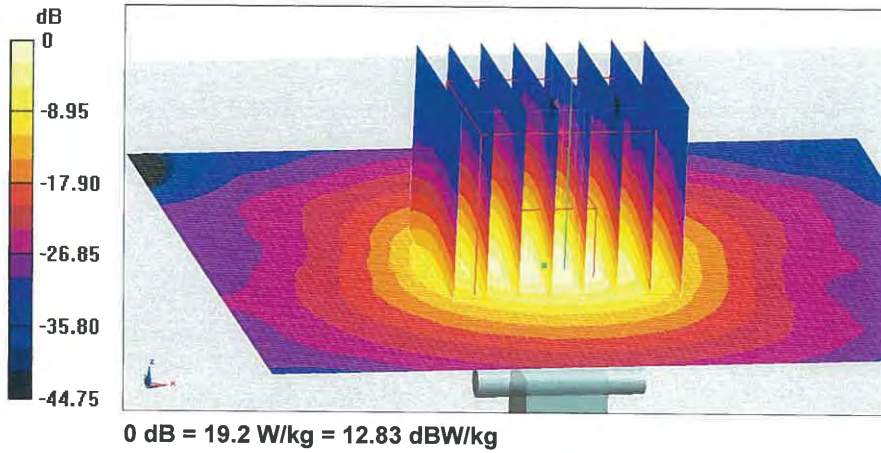



Add: No.51 Xueyuan Road, Haidian District, Beijing, 100191, China  
Tel: +86-10-62304633-2512 Fax: +86-10-62304633-2504  
E-mail: cttl@chinattl.com http://www.chinattl.cn

### Impedance Measurement Plot for Head TSL

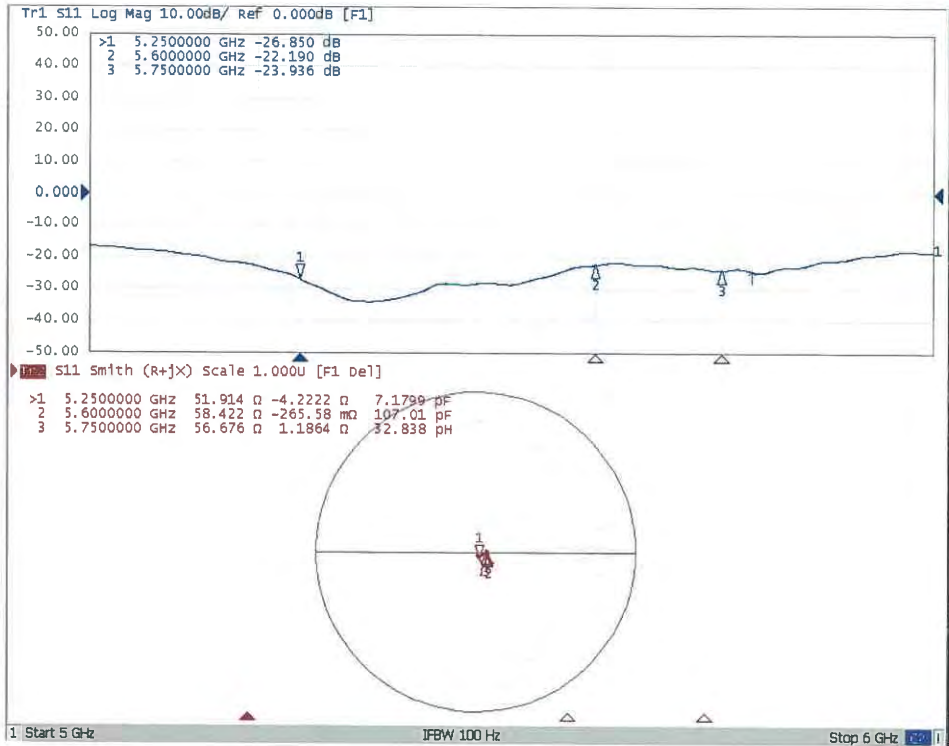



Add: No.51 Xueyuan Road, Haidian District, Beijing, 100191, China  
Tel: +86-10-62304633-2512 Fax: +86-10-62304633-2504  
E-mail: cttl@chinattl.com http://www.chinattl.cn

## DASY5 Validation Report for Body TSL

Date: 04.19.2019

Test Laboratory: CTTL, Beijing, China

**DUT: Dipole 5GHz; Type: D5GHzV2; Serial: D5GHzV2 - SN: 1021**

Communication System: CW; Frequency: 5250 MHz, Frequency: 5600 MHz, Frequency: 5750 MHz,

Medium parameters used:  $f = 5250$  MHz;  $\sigma = 5.492$  S/m;  $\epsilon_r = 50.32$ ;  $\rho = 1000$  kg/m<sup>3</sup>, Medium parameters used:  $f = 5600$  MHz;  $\sigma = 5.937$  S/m;  $\epsilon_r = 49.85$ ;  $\rho = 1000$  kg/m<sup>3</sup>, Medium parameters used:  $f = 5750$  MHz;  $\sigma = 6.109$  S/m;  $\epsilon_r = 49.74$ ;  $\rho = 1000$  kg/m<sup>3</sup>,

Phantom section: Right Section

DASY5 Configuration:

- Probe: EX3DV4 - SN7514; ConvF(4.54, 4.54, 4.54) @ 5250 MHz; Calibrated: 8/27/2018, ConvF(4, 4, 4) @ 5600 MHz; Calibrated: 8/27/2018, ConvF(3.98, 3.98, 3.98) @ 5750 MHz; Calibrated: 8/27/2018,
- Sensor-Surface: 1.4mm (Mechanical Surface Detection)
- Electronics: DAE4 Sn1331; Calibrated: 2/6/2019
- Phantom: MFP\_V5.1C ; Type: QD 000 P51CA; Serial: 1062
- Measurement SW: DASY52, Version 52.10 (2); SEMCAD X Version 14.6.12 (7450)

**Dipole Calibration /Pin=100mW, d=10mm, f=5250 MHz/Zoom Scan,**

**dist=1.4mm (8x8x7)/Cube 0:** Measurement grid: dx=4mm, dy=4mm, dz=1.4mm

Reference Value = 58.99 V/m; Power Drift = 0.00 dB

Peak SAR (extrapolated) = 29.9 W/kg

**SAR(1 g) = 7.39 W/kg; SAR(10 g) = 2.09 W/kg**

Maximum value of SAR (measured) = 17.3 W/kg

**Dipole Calibration /Pin=100mW, d=10mm, f=5600 MHz/Zoom Scan,**

**dist=1.4mm (8x8x7)/Cube 0:** Measurement grid: dx=4mm, dy=4mm, dz=1.4mm

Reference Value = 54.86 V/m; Power Drift = 0.01 dB

Peak SAR (extrapolated) = 35.6 W/kg

**SAR(1 g) = 7.65 W/kg; SAR(10 g) = 2.16 W/kg**

Maximum value of SAR (measured) = 19.2 W/kg

**Dipole Calibration /Pin=100mW, d=10mm, f=5750 MHz/Zoom Scan,**

**dist=1.4mm (8x8x7)/Cube 0:** Measurement grid: dx=4mm, dy=4mm, dz=1.4mm

Reference Value = 55.96 V/m; Power Drift = 0.02 dB

Peak SAR (extrapolated) = 35.0 W/kg

**SAR(1 g) = 7.41 W/kg; SAR(10 g) = 2.08 W/kg**

Maximum value of SAR (measured) = 18.5 W/kg

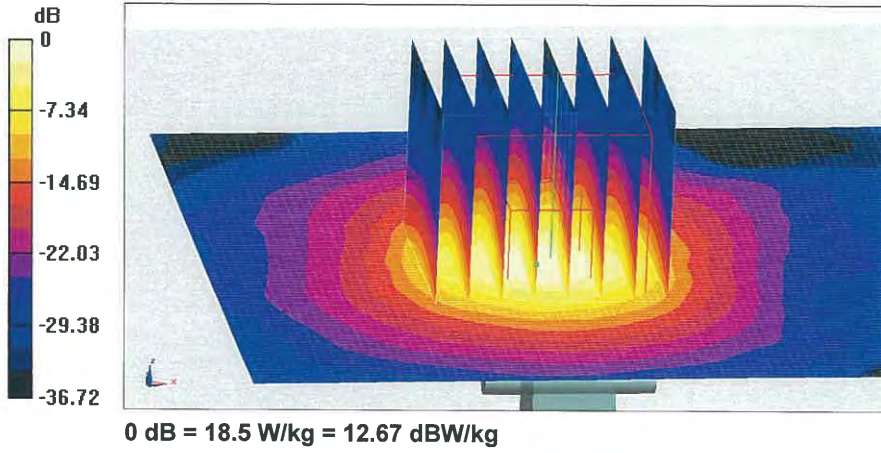



Add: No.51 Xueyuan Road, Haidian District, Beijing, 100191, China  
Tel: +86-10-62304633-2512 Fax: +86-10-62304633-2504  
E-mail: cttl@chinattl.com http://www.chinattl.cn

### Impedance Measurement Plot for Body TSL

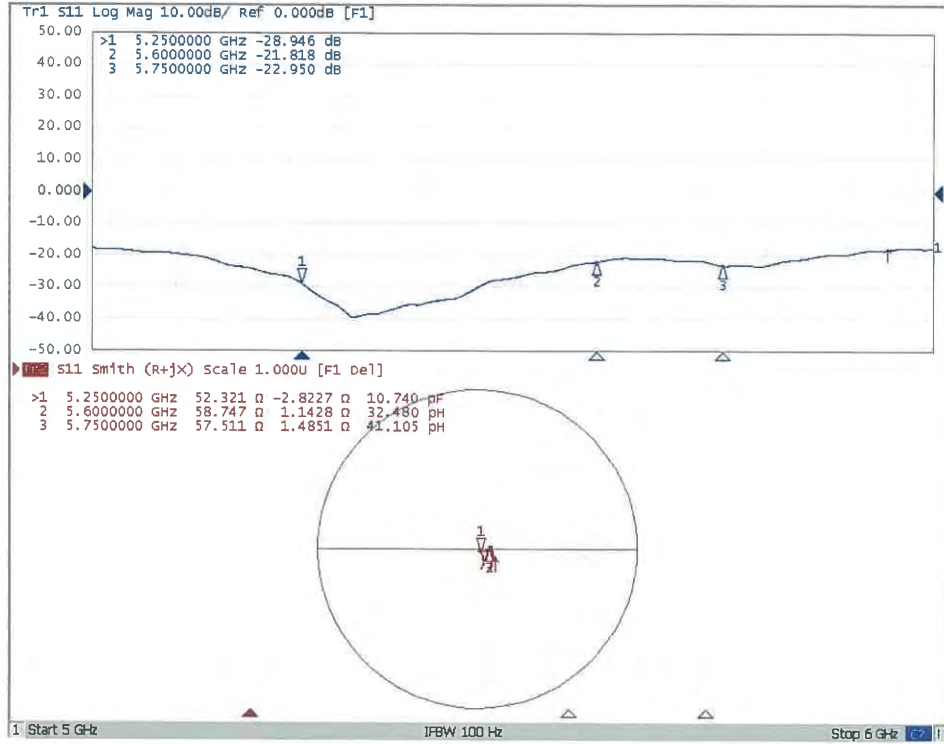





In Collaboration with  
**s p e a g**  
CALIBRATION LABORATORY



中国认可  
国际互认  
校准  
CALIBRATION  
CNAS L0570

Add: No.51 Xueyuan Road, Haidian District, Beijing, 100191, China  
Tel: +86-10-62304633-2512 Fax: +86-10-62304633-2504  
E-mail: cttl@chinattl.com [Http://www.chinattl.cn](http://www.chinattl.cn)

Client **Auden**

Certificate No: **Z18-60104**

## CALIBRATION CERTIFICATE

Object **EX3DV4 - SN:3578**

Calibration Procedure(s) **FF-Z11-004-01**  
**Calibration Procedures for Dosimetric E-field Probes**

Calibration date: **May 29, 2018**

This calibration Certificate documents the traceability to national standards, which realize the physical units of measurements(SI). The measurements and the uncertainties with confidence probability are given on the following pages and are part of the certificate.

All calibrations have been conducted in the closed laboratory facility: environment temperature(22±3)°C and humidity<70%.

Calibration Equipment used (M&TE critical for calibration)

Primary Standards	ID #	Cal Date(Calibrated by, Certificate No.)	Scheduled Calibration
Power Meter NRP2	101919	27-Jun-17 (CTTL, No.J17X05857)	Jun-18
Power sensor NRP-Z91	101547	27-Jun-17 (CTTL, No.J17X05857)	Jun-18
Power sensor NRP-Z91	101548	27-Jun-17 (CTTL, No.J17X05857)	Jun-18
Reference10dBAttenuator	18N50W-10dB	09-Feb-18(CTTL, No.J18X01133)	Feb-20
Reference20dBAttenuator	18N50W-20dB	09-Feb-18(CTTL, No.J18X01132)	Feb-20
Reference Probe EX3DV4	SN 3846	25-Jan-18(SPEAG,No.EX3-3846_Jan18)	Jan-19
DAE4	SN 777	15-Dec-17(SPEAG, No.DAE4-777_Dec17)	Dec -18
Secondary Standards	ID #	Cal Date(Calibrated by, Certificate No.)	Scheduled Calibration
SignalGeneratorMG3700A	6201052605	27-Jun-17 (CTTL, No.J17X05858)	Jun-18
Network Analyzer E5071C	MY46110673	14-Jan-18 (CTTL, No.J18X00561)	Jan -19

	Name	Function	Signature
Calibrated by:	Yu Zongying	SAR Test Engineer	
Reviewed by:	Lin Hao	SAR Test Engineer	
Approved by:	Qi Dianyuan	SAR Project Leader	

Issued: May 31, 2018

This calibration certificate shall not be reproduced except in full without written approval of the laboratory.

Certificate No: Z18-60104

Page 1 of 11

### Glossary:

TSL	tissue simulating liquid
NORM <sub>x,y,z</sub>	sensitivity in free space
ConvF	sensitivity in TSL / NORM <sub>x,y,z</sub>
DCP	diode compression point
CF	crest factor (1/duty_cycle) of the RF signal
A,B,C,D	modulation dependent linearization parameters
Polarization $\Phi$	$\Phi$ rotation around probe axis
Polarization $\theta$	$\theta$ rotation around an axis that is in the plane normal to probe axis (at measurement center), i $\theta=0$ is normal to probe axis

Connector Angle information used in DASY system to align probe sensor X to the robot coordinate system

### Calibration is performed According to the Following Standards:

- IEEE Std 1528-2013, "IEEE Recommended Practice for Determining the Peak Spatial-Averaged Specific Absorption Rate (SAR) in the Human Head from Wireless Communications Devices: Measurement Techniques", June 2013
- IEC 62209-1, "Measurement procedure for the assessment of Specific Absorption Rate (SAR) from hand-held and body-mounted devices used next to the ear (frequency range of 300 MHz to 6 GHz)", July 2016
- IEC 62209-2, "Procedure to determine the Specific Absorption Rate (SAR) for wireless communication devices used in close proximity to the human body (frequency range of 30 MHz to 6 GHz)", March 2010
- KDB 865664, "SAR Measurement Requirements for 100 MHz to 6 GHz"

### Methods Applied and Interpretation of Parameters:

- NORM<sub>x,y,z</sub>**: Assessed for E-field polarization  $\theta=0$  ( $f \leq 900\text{MHz}$  in TEM-cell;  $f > 1800\text{MHz}$ : waveguide). NORM<sub>x,y,z</sub> are only intermediate values, i.e., the uncertainties of NORM<sub>x,y,z</sub> does not effect the  $E^2$ -field uncertainty inside TSL (see below ConvF).
- NORM(f)<sub>x,y,z</sub> = NORM<sub>x,y,z</sub> \* frequency\_response** (see Frequency Response Chart). This linearization is implemented in DASY4 software versions later than 4.2. The uncertainty of the frequency response is included in the stated uncertainty of ConvF.
- DCP<sub>x,y,z</sub>**: DCP are numerical linearization parameters assessed based on the data of power sweep (no uncertainty required). DCP does not depend on frequency nor media.
- PAR**: PAR is the Peak to Average Ratio that is not calibrated but determined based on the signal characteristics.
- A<sub>x,y,z</sub>; B<sub>x,y,z</sub>; C<sub>x,y,z</sub>; VR<sub>x,y,z</sub>; A,B,C** are numerical linearization parameters assessed based on the data of power sweep for specific modulation signal. The parameters do not depend on frequency nor media. VR is the maximum calibration range expressed in RMS voltage across the diode.
- ConvF and Boundary Effect Parameters**: Assessed in flat phantom using E-field (or Temperature Transfer Standard for  $f \leq 800\text{MHz}$ ) and inside waveguide using analytical field distributions based on power measurements for  $f > 800\text{MHz}$ . The same setups are used for assessment of the parameters applied for boundary compensation (alpha, depth) of which typical uncertainty valued are given. These parameters are used in DASY4 software to improve probe accuracy close to the boundary. The sensitivity in TSL corresponds to NORM<sub>x,y,z</sub> \* ConvF whereby the uncertainty corresponds to that given for ConvF. A frequency dependent ConvF is used in DASY version 4.4 and higher which allows extending the validity from  $\pm 50\text{MHz}$  to  $\pm 100\text{MHz}$ .
- Spherical isotropy (3D deviation from isotropy)**: in a field of low gradients realized using a flat phantom exposed by a patch antenna.
- Sensor Offset**: The sensor offset corresponds to the offset of virtual measurement center from the probe tip (on probe axis). No tolerance required.
- Connector Angle**: The angle is assessed using the information gained by determining the NORM<sub>x</sub> (no uncertainty required).

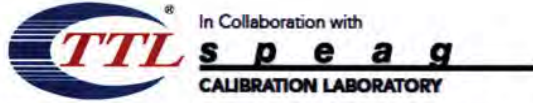

Add: No.51 Xueyuan Road, Haidian District, Beijing, 100191, China  
Tel: +86-10-62304633-2512 Fax: +86-10-62304633-2504  
E-mail: [ctl@chinattl.com](mailto:ctl@chinattl.com) [Http://www.chinattl.cn](http://www.chinattl.cn)

# Probe EX3DV4

SN: 3578

Calibrated: May 29, 2018

Calibrated for DASY/EASY Systems

(Note: non-compatible with DASY2 system!)

## DASY/EASY – Parameters of Probe: EX3DV4 – SN: 3578

### Basic Calibration Parameters

	Sensor X	Sensor Y	Sensor Z	Unc (k=2)
Norm( $\mu\text{V}/(\text{V}/\text{m})^2$ ) <sup>A</sup>	0.42	0.38	0.45	±10.0%
DCP(mV) <sup>B</sup>	104.5	108.3	108.1	

### Modulation Calibration Parameters

UID	Communication System Name		A dB	B dB $\sqrt{\mu\text{V}}$	C	D dB	VR mV	Unc <sup>E</sup> (k=2)
0	CW	X	0.0	0.0	1.0	0.00	151.8	±2.2%
		Y	0.0	0.0	1.0		142.8	
		Z	0.0	0.0	1.0		161.3	

The reported uncertainty of measurement is stated as the standard uncertainty of Measurement multiplied by the coverage factor k=2, which for a normal distribution Corresponds to a coverage probability of approximately 95%.

<sup>A</sup> The uncertainties of Norm X, Y, Z do not affect the E<sup>2</sup>-field uncertainty inside TSL (see Page 5 and Page 6).

<sup>B</sup> Numerical linearization parameter: uncertainty not required.

<sup>E</sup> Uncertainty is determined using the max. deviation from linear response applying rectangular distribution and is expressed for the square of the field value.

## DASY/EASY – Parameters of Probe: EX3DV4 – SN: 3578

### Calibration Parameter Determined in Head Tissue Simulating Media

f [MHz] <sup>C</sup>	Relative Permittivity <sup>F</sup>	Conductivity (S/m) <sup>F</sup>	ConvF X	ConvF Y	ConvF Z	Alpha <sup>G</sup>	Depth <sup>G</sup> (mm)	Unct. (k=2)
750	41.9	0.89	9.69	9.69	9.69	0.40	0.80	±12.1%
835	41.5	0.90	9.36	9.36	9.36	0.12	1.69	±12.1%
900	41.5	0.97	9.49	9.49	9.49	0.15	1.40	±12.1%
1750	40.1	1.37	8.20	8.20	8.20	0.18	1.16	±12.1%
1900	40.0	1.40	7.93	7.93	7.93	0.20	1.09	±12.1%
2000	40.0	1.40	8.10	8.10	8.10	0.22	1.05	±12.1%
2300	39.5	1.67	7.96	7.96	7.96	0.40	0.75	±12.1%
2450	39.2	1.80	7.51	7.51	7.51	0.40	0.90	±12.1%
2600	39.0	1.96	7.30	7.30	7.30	0.51	0.76	±12.1%
3500	37.9	2.91	6.93	6.93	6.93	0.57	0.95	±13.3%
5250	35.9	4.71	5.44	5.44	5.44	0.40	1.45	±13.3%
5600	35.5	5.07	4.75	4.75	4.75	0.45	1.15	±13.3%
5750	35.4	5.22	4.78	4.78	4.78	0.45	1.55	±13.3%

<sup>C</sup> Frequency validity above 300 MHz of ±100MHz only applies for DASY v4.4 and higher (Page 2), else it is restricted to ±50MHz. The uncertainty is the RSS of ConvF uncertainty at calibration frequency and the uncertainty for the indicated frequency band. Frequency validity below 300 MHz is ± 10, 25, 40, 50 and 70 MHz for ConvF assessments at 30, 64, 128, 150 and 220 MHz respectively. Above 5 GHz frequency validity can be extended to ± 110 MHz.

<sup>F</sup> At frequency below 3 GHz, the validity of tissue parameters ( $\epsilon$  and  $\sigma$ ) can be relaxed to ±10% if liquid compensation formula is applied to measured SAR values. At frequencies above 3 GHz, the validity of tissue parameters ( $\epsilon$  and  $\sigma$ ) is restricted to ±5%. The uncertainty is the RSS of the ConvF uncertainty for indicated target tissue parameters.

<sup>G</sup> Alpha/Depth are determined during calibration. SPEAG warrants that the remaining deviation due to the boundary effect after compensation is always less than ± 1% for frequencies below 3 GHz and below ± 2% for the frequencies between 3-6 GHz at any distance larger than half the probe tip diameter from the boundary.

## DASY/EASY – Parameters of Probe: EX3DV4 – SN: 3578

### Calibration Parameter Determined in Body Tissue Simulating Media

f [MHz] <sup>C</sup>	Relative Permittivity <sup>F</sup>	Conductivity (S/m) <sup>F</sup>	ConvF X	ConvF Y	ConvF Z	Alpha <sup>G</sup>	Depth <sup>G</sup> (mm)	Unct. (k=2)
750	55.5	0.96	9.89	9.89	9.89	0.40	0.80	±12.1%
835	55.2	0.97	9.49	9.49	9.49	0.18	1.39	±12.1%
900	55.0	1.05	9.45	9.45	9.45	0.22	1.19	±12.1%
1750	53.4	1.49	7.92	7.92	7.92	0.18	1.18	±12.1%
1900	53.3	1.52	7.68	7.68	7.68	0.17	1.28	±12.1%
2000	53.3	1.52	7.88	7.88	7.88	0.20	1.18	±12.1%
2300	52.9	1.81	7.65	7.65	7.65	0.50	0.83	±12.1%
2450	52.7	1.95	7.44	7.44	7.44	0.35	1.14	±12.1%
2600	52.5	2.16	7.12	7.12	7.12	0.52	0.81	±12.1%
3500	51.3	3.31	6.57	6.57	6.57	0.64	0.91	±13.3%
5250	48.9	5.36	4.96	4.96	4.96	0.55	1.25	±13.3%
5600	48.5	5.77	4.22	4.22	4.22	0.48	1.40	±13.3%
5750	48.3	5.94	4.34	4.34	4.34	0.49	1.45	±13.3%

<sup>C</sup> Frequency validity above 300 MHz of ±100MHz only applies for DASY v4.4 and higher (Page 2), else it is restricted to ±50MHz. The uncertainty is the RSS of ConvF uncertainty at calibration frequency and the uncertainty for the indicated frequency band. Frequency validity below 300 MHz is ± 10, 25, 40, 50 and 70 MHz for ConvF assessments at 30, 64, 128, 150 and 220 MHz respectively. Above 5 GHz frequency validity can be extended to ± 110 MHz.

<sup>F</sup> At frequency below 3 GHz, the validity of tissue parameters ( $\epsilon$  and  $\sigma$ ) can be relaxed to ±10% if liquid compensation formula is applied to measured SAR values. At frequencies above 3 GHz, the validity of tissue parameters ( $\epsilon$  and  $\sigma$ ) is restricted to ±5%. The uncertainty is the RSS of the ConvF uncertainty for indicated target tissue parameters.

<sup>G</sup> Alpha/Depth are determined during calibration. SPEAG warrants that the remaining deviation due to the boundary effect after compensation is always less than ± 1% for frequencies below 3 GHz and below ± 2% for the frequencies between 3-6 GHz at any distance larger than half the probe tip diameter from the boundary.

## Frequency Response of E-Field (TEM-Cell: ifi110 EXX, Waveguide: R22)

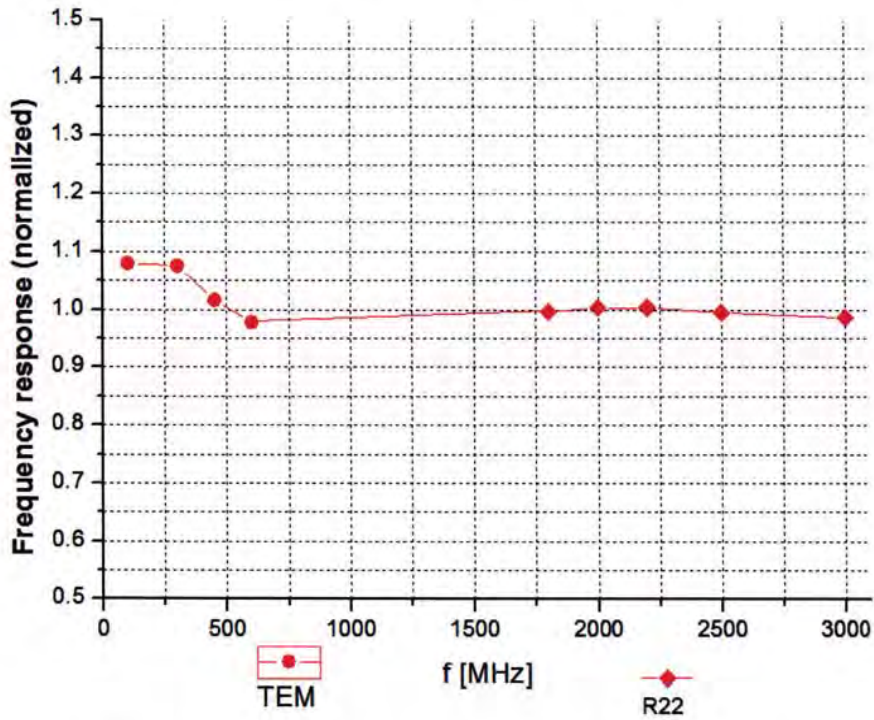

Uncertainty of Frequency Response of E-field:  $\pm 7.4\%$  ( $k=2$ )

### Receiving Pattern ( $\Phi$ ), $\theta=0^\circ$

**f=600 MHz, TEM**

**f=1800 MHz, R22**

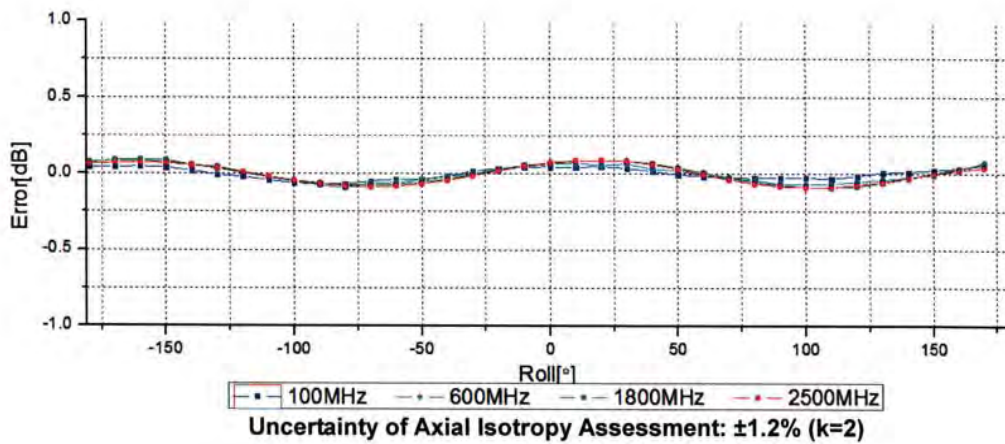
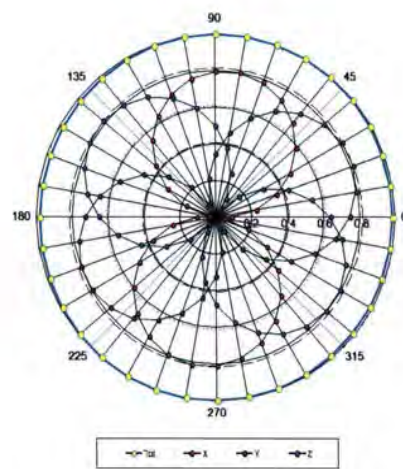
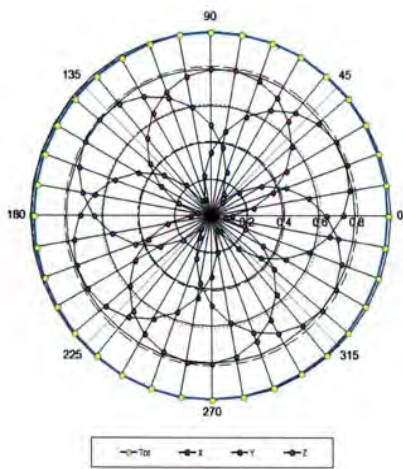



### Dynamic Range f(SAR<sub>head</sub>) (TEM cell, f = 900 MHz)

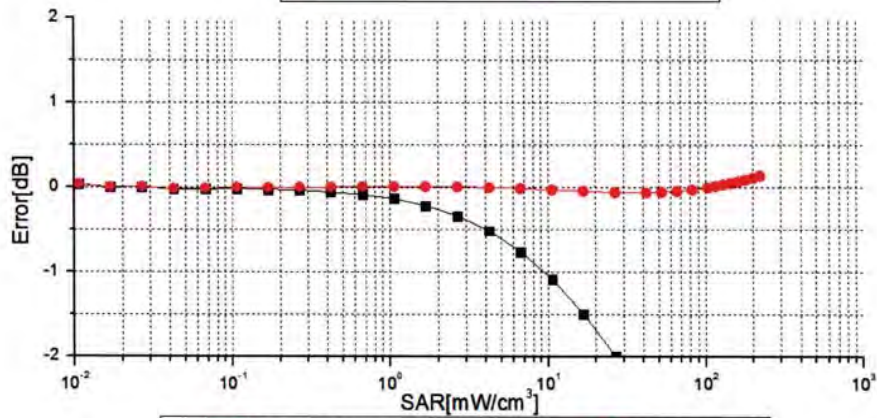
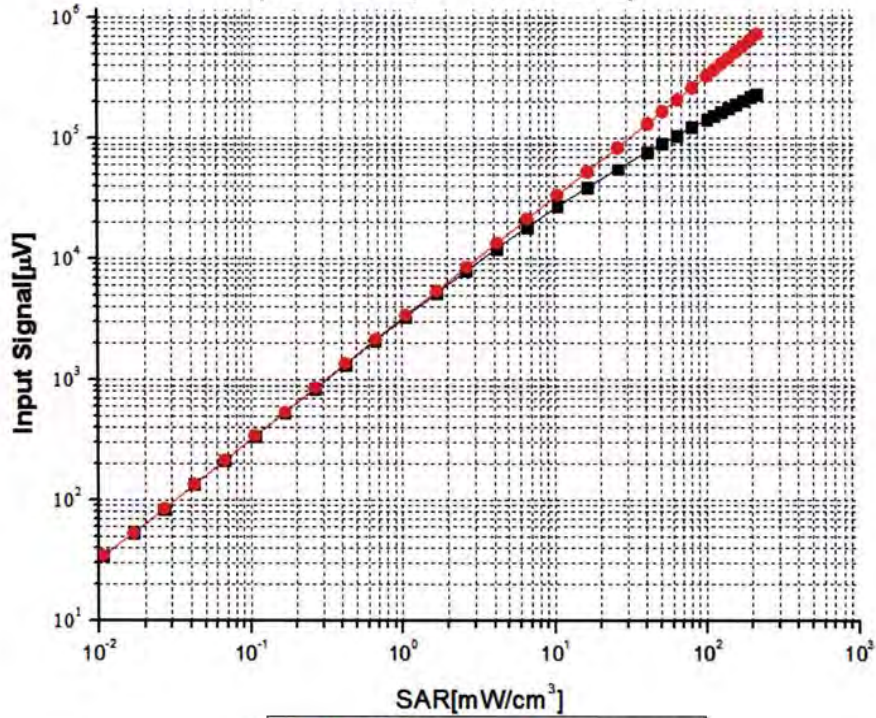

Uncertainty of Linearity Assessment: ±0.9% (k=2)

## Conversion Factor Assessment

f=750 MHz, WGLS R9(H\_convF)

f=1750 MHz, WGLS R22(H\_convF)

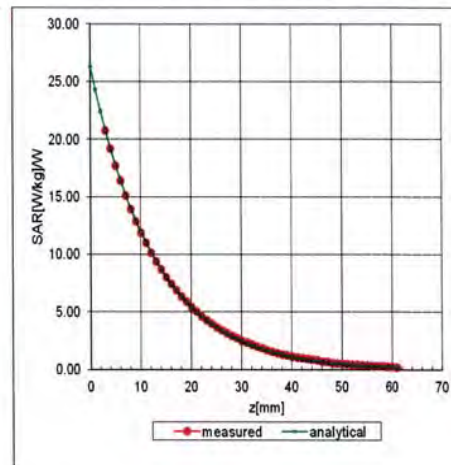
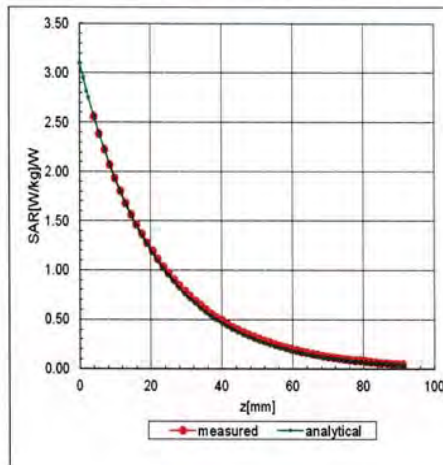

## Deviation from Isotropy in Liquid

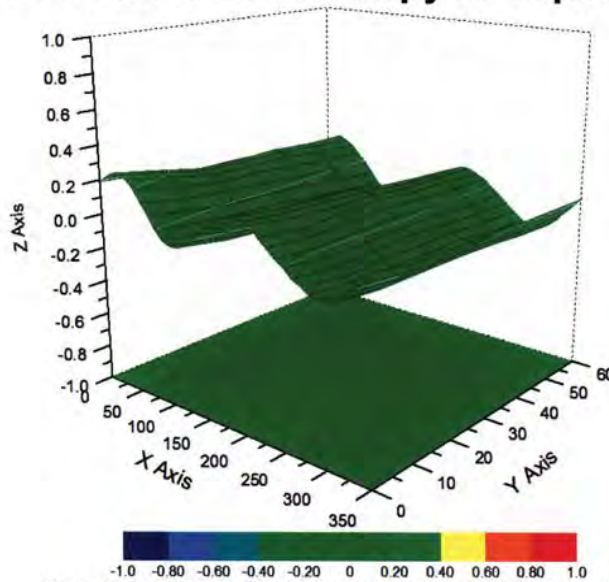

Uncertainty of Spherical Isotropy Assessment:  $\pm 3.2\%$  (K=2)

## DASY/EASY – Parameters of Probe: EX3DV4 – SN: 3578

### Other Probe Parameters

Sensor Arrangement	Triangular
Connector Angle (°)	169.7
Mechanical Surface Detection Mode	enabled
Optical Surface Detection Mode	disable
Probe Overall Length	337mm
Probe Body Diameter	10mm
Tip Length	9mm
Tip Diameter	2.5mm
Probe Tip to Sensor X Calibration Point	1mm
Probe Tip to Sensor Y Calibration Point	1mm
Probe Tip to Sensor Z Calibration Point	1mm
Recommended Measurement Distance from Surface	1.4mm



In Collaboration with  
**s p e a g**  
CALIBRATION LABORATORY



中国认可  
国际互认  
校准  
CALIBRATION  
CNAS L0570

MR-008\_19-056

Add: No.51 Xueyuan Road, Haidian District, Beijing, 100191, China  
Tel: +86-10-62304633-2512 Fax: +86-10-62304633-2504  
E-mail: cttl@chinattl.com [Http://www.chinattl.cn](http://www.chinattl.cn)

Client : **ATL**

Certificate No: **Z19-60080**

## CALIBRATION CERTIFICATE

Object: **DAE4 - SN: 541**

Calibration Procedure(s): **FF-Z11-002-01**  
Calibration Procedure for the Data Acquisition Electronics (DAEx)

Calibration date: **March 19, 2019**

This calibration Certificate documents the traceability to national standards, which realize the physical units of measurements(SI). The measurements and the uncertainties with confidence probability are given on the following pages and are part of the certificate.

All calibrations have been conducted in the closed laboratory facility: environment temperature(22±3)°C and humidity<70%.

Calibration Equipment used (M&TE critical for calibration)

Primary Standards	ID #	Cal Date(Calibrated by, Certificate No.)	Scheduled Calibration
Process Calibrator 753	1971018	20-Jun-18 (CTTL, No.J18X05034)	June-19

	Name	Function	Signature
Calibrated by:	Yu Zongying	SAR Test Engineer	
Reviewed by:	Lin Hao	SAR Test Engineer	
Approved by:	Qi Dianyuan	SAR Project Leader	

Issued: March 20, 2019

This calibration certificate shall not be reproduced except in full without written approval of the laboratory.

Certificate No: Z19-60080

Page 1 of 3



Add: No.51 Xueyuan Road, Haidian District, Beijing, 100191, China  
Tel: +86-10-62304633-2512 Fax: +86-10-62304633-2504  
E-mail: cttl@chinatl.com Http://www.chinatl.cn

#### **Glossary:**

DAE data acquisition electronics  
Connector angle information used in DASY system to align probe sensor X to the robot coordinate system.

#### **Methods Applied and Interpretation of Parameters:**

- *DC Voltage Measurement:* Calibration Factor assessed for use in DASY system by comparison with a calibrated instrument traceable to national standards. The figure given corresponds to the full scale range of the voltmeter in the respective range.
- *Connector angle:* The angle of the connector is assessed measuring the angle mechanically by a tool inserted. Uncertainty is not required.
- The report provide only calibration results for DAE, it does not contain other performance test results.



Add: No.51 Xueyuan Road, Haidian District, Beijing, 100191, China  
 Tel: +86-10-62304633-2512 Fax: +86-10-62304633-2504  
 E-mail: cttl@chinattl.com Http://www.chinattl.cn

**DC Voltage Measurement**

A/D - Converter Resolution nominal

High Range: 1LSB = 6.1μV , full range = -100...+300 mV  
 Low Range: 1LSB = 61nV , full range = -1.....+3mV

DASY measurement parameters: Auto Zero Time: 3 sec; Measuring time: 3 sec

Calibration Factors	X	Y	Z
High Range	404.544 ± 0.15% (k=2)	404.406 ± 0.15% (k=2)	404.170 ± 0.15% (k=2)
Low Range	3.96863 ± 0.7% (k=2)	3.93444 ± 0.7% (k=2)	3.97515 ± 0.7% (k=2)

**Connector Angle**

Connector Angle to be used in DASY system	288.5° ± 1 °
---	--------------