



TEST REPORT

Report Number: 0234159U.doc

Project Number: 3034159

November 12, 2002

**Evaluation of the
Dual Band Tri-mode CDMA Cellular Phone**

Model Number: T608

FCC ID: PXITR-CA0802

IC: 4170A-CA0802

to

FCC Part 15

FCC Part 22 Subpart H

FCC Part 24 Subpart E

IC RSS-129

IC RSS-133

For

Sony Ericsson Mobile Communications Inc.

Test Performed by:

Intertek Testing Services
1950 Evergreen Blvd, Suite 100
Duluth, GA 30096

Test Authorized by:

Sony Ericsson Mobile Communications Inc.
7001 Development Drive
Research Triangle Park, NC 27709

Prepared by:

Jeffrey D. Hiday, Senior Project Engineer

Date:

11/14/02

Reviewed by:

David J. Schramm, EMC Team Leader

Date:

11/14/02

All services undertaken are subject to the following general policy: Reports are submitted for exclusive use of the client to whom they are addressed. Their significance is subject to the adequacy and representative character of the samples and to the comprehensiveness of the tests, examinations or surveys made. This report shall not be reproduced except in full, without written consent of Intertek Testing Services NA Inc. This report must not be used to claim product endorsement by A2LA, NIST nor any other agency of the U.S. Government.

TABLE OF CONTENTS

EXECUTIVE SUMMARY..... 4

1 JOB DESCRIPTION..... 5

1.1 CLIENT INFORMATION.....5

1.2 TEST PLAN REFERENCE:.....5

1.3 EQUIPMENT UNDER TEST (EUT)6

 1.3.1 System Support Equipment..... 7

 1.3.2 Cables associated with EUT..... 7

 1.3.3 System Block Diagram..... 7

 1.3.4 Justification..... 8

 1.3.5 Mode(s) of operation..... 8

1.4 MODIFICATIONS REQUIRED FOR COMPLIANCE8

1.5 RELATED SUBMITTAL(S) GRANTS.....8

2 TEST FACILITY..... 9

3 CONDUCTED RF POWER..... 10

3.1 TEST PROCEDURE..... 10

3.2 TEST EQUIPMENT 10

3.3 TEST RESULTS..... 10

4 RADIATED RF POWER..... 12

4.1 TEST PROCEDURE..... 12

4.2 TEST EQUIPMENT 12

4.3 TEST RESULTS..... 13

5 MODULATION DEVIATION LIMITING..... 14

5.1 TEST PROCEDURE..... 14

5.2 TEST EQUIPMENT 14

5.3 TEST RESULTS..... 14

6 AUDIO FILTER CHARACTERISTICS..... 17

6.1 TEST PROCEDURE..... 17

6.2 TEST EQUIPMENT 18

6.3 TEST RESULTS..... 18

7 EMISSION LIMITATIONS, OCCUPIED BANDWIDTH..... 20

7.1 TEST PROCEDURE..... 20

7.2 TEST EQUIPMENT 20

7.3 TEST RESULTS..... 21

8 OUT OF BAND EMISSION AT ANTENNA TERMINALS 25

8.1 TEST PROCEDURE..... 25

8.2 TEST EQUIPMENT 25

8.3 TEST RESULTS..... 26

9 FIELD STRENGTH OF SPURIOUS RADIATION..... 35

9.1 TEST PROCEDURE..... 35

9.2 TEST EQUIPMENT 35

Intertek Testing Services

9.3	TEST RESULTS.....	35
10	POWER LINE CONDUCTED EMISSIONS.....	36
10.1	TEST PROCEDURE.....	36
10.2	TEST EQUIPMENT.....	36
10.3	TEST RESULTS.....	36
10.4	TEST CONFIGURATION PHOTOGRAPH.....	39
11	FREQUENCY STABILITY VS TEMPERATURE.....	41
11.1	TEST PROCEDURE.....	41
11.2	TEST EQUIPMENT.....	41
11.3	TEST RESULTS.....	41
12	FREQUENCY STABILITY VS VOLTAGE.....	43
12.1	TEST PROCEDURE.....	43
12.2	TEST EQUIPMENT.....	43
12.3	TEST RESULTS.....	43
13	RECEIVER SPURIOUS EMISSIONS.....	45
13.1	TEST LIMITS.....	45
13.2	TEST EQUIPMENT.....	45
13.3	TEST PROCEDURE.....	45
13.4	TEST RESULTS.....	46
13.5	TEST CONFIGURATION PHOTOGRAPH.....	47

Intertek Testing Services

Executive Summary

Testing performed for: Sony Ericsson Mobile Communications Inc.

Equipment Under Test: T608, Dual Band Tri-mode CDMA Cellular Phone

FCC RULE	IC RULE	DESCRIPTION OF TEST	RESULT	PAGE
§2.1046	RSS-129 §7.1, §9.1 RSS-133 §6.2	RF Power Output	Passed	10
§22.913, §24.232	RSS-129 §7.1, §9.1 RSS-133 §6.2	ERP, EIRP	Passed	13
§2.1047 §22.915(b)(c)	RSS-129 §5.9, §6.1	Modulation Deviation Limiting	Passed	14
§22.915(d)(1)	RSS-129 §6.2	Audio Filter Characteristics	Passed	18
§2.1049 §22.917(b)(d)	RSS-129 §6.3, RSS-129 §8.1	Emission Limitation, Occupied Bandwidth	Passed	20
§2.1051 §22.917(e) §22.917(f) §24.238(a)	RSS-129 §6.3, §7.2.2, §8.1.1, §10 RSS-133 §6.3	Out of Band Emissions at Antenna Terminals Mobile Emissions In Base Frequency Range	Passed	25
§2.1053	RSS-129 §8.1	Field Strength of Spurious Radiation	Passed	35
§15.107, §15.207	IC ES-003	Power Line Conducted Emissions	Passed	36
§2.1055, §22.355, §24.235	RSS-133 §7	Frequency Stability vs. Temperature	Passed	41
§2.1055, §22.355, §24.235	--	Frequency Stability vs. Voltage	Passed	43
§2.1091, §2.1093	RSS-129 §11, RSS-133 §8	Specific Absorption Rate	N/S	See Note ¹
§15.109	IC ES-003 RSS-129 §10, RSS-133 §9	Receiver Spurious Emission	Passed	45

N/S: Not under scope of this evaluation

¹ Specific Absorption Rate testing was not under the scope of this evaluation.

1 JOB DESCRIPTION

1.1 Client information

The Dual Band Tri-mode CDMA Cellular Phone has been tested at the request of

Company: Sony Ericsson Mobile Communications Inc.
7001 Development Drive
Research Triangle Park, NC 27709

Name of contact: Pierre Chery
Telephone: 919-472-1697
Fax: 919-472-6382

1.2 Test plan reference:

Tests were performed to the following standards:

- FCC Part 15
- FCC Part 22 Subpart H rules for an intentional radiator
- FCC Part 24 Subpart E rules for an intentional radiator
- IC RSS-129
- IC RSS-133

The test procedures described in this test report and ANSI C63.4: 1992 were employed.

Intertek Testing Services

1.3 Equipment Under Test (EUT)

Product	Dual Band Tri-mode CDMA Cellular Phone
EUT Model Number	T608
EUT Serial Number	UA2020P5R8 (conducted tests); UA2020P5S3 (radiated tests)
Whether quantity (>1) production is planned	Quantity production is planned.
Cellular Phone standards	AMPS, CDMA800 and CDMA1900
Type(s) of Emission	40K0F8W, 40K0F1D, 1M29G9W
RF Output Power	824-849 MHz: 26.5 dBm – AMPS 824-849 MHz: 23.8 dBm – CDMA800 1850-1910 MHz: 23.9 dBm – CDMA1900
Frequency Range	824 – 849 AMPS and CDMA800 1850 – 1910 CDMA1900
Antenna & Gain	Integrated, non-retractable (internal)
Detachable Antenna ?	No
External input	<input checked="" type="checkbox"/> Audio <input type="checkbox"/> Digital Data

EUT receive date: November 1, 2002
EUT receive condition: The EUT was received in good condition with no apparent damage.
Test start date: November 4, 2002
Test completion date: November 11, 2002

The test results in this report pertain only to the item tested.

1.3.1 System Support Equipment

Table 1-1 contains the details of the support equipment associated with the Equipment Under Test during the FCC Part 15 and ICES-003 testing.

Table 1-1: System Support Equipment

Description	Manufacturer	Model Number	Serial Number	FCC ID number
Hands-free accessory	Sony Ericsson	RLF 501 25/03	Not labeled	Not labeled
Home charging base	Sony Ericsson (Salcomp)	CST-15 GSAC-MN2 (Type 4020075-US)	Not labeled	Not labeled
Home charging base	Sony Ericsson (Salcomp)	CST-12 (Type 402 0068US) (316AMS43001)	0130	Not labeled
Home charging base	Sony Ericsson (Salcomp)	CST-16	242000000700	Not labeled

1.3.2 Cables associated with EUT

Table 1-2 contains the details of the cables associated with the EUT.

Table 1-2: Interconnecting cables between modules of EUT

Cables					
Description	Length	Shielding	Ferrites	Connection	
				From	To
Adapter cable	2m	None	None	EUT	Charging adapter
Hands free	1.2m	None	None	EUT	Ear piece

1.3.3 System Block Diagram

The diagram shown below details the interconnection of the EUT and its accessories during FCC Part 15 testing. For specific layout, refer to the test configuration photograph in the relevant section of this report.

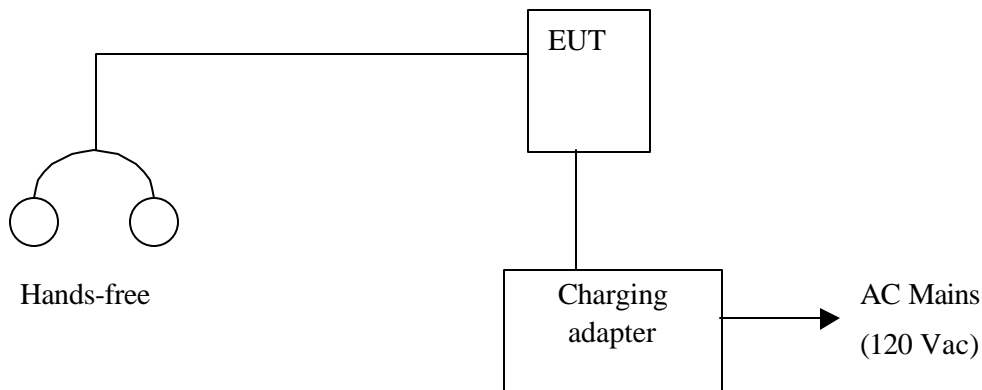

1.3.4 Justification

The EUT was operated in the stand-alone configuration.

1.3.5 Mode(s) of operation

The EUT was powered from 3.8 Vdc. For the radiated transmitter power and radiated transmitter spurious emissions, a fully charged battery was used. For antenna port measurements, the 3.8 Vdc was supplied by a bench top power supply.

The EUT was set to the AMPS, CDMA800, or CDMA1900 mode during testing.

1.4 Modifications required for compliance

No modifications were implemented by Intertek Testing Services.

1.5 Related Submittal(s) Grants

None

2 TEST FACILITY

The ITS-Duluth site is located at 1950 Evergreen Blvd., Suite 100, Duluth, Georgia. The radiated emission test site is a 10-meter semi-anechoic chamber. The chamber meets the characteristics of CISPR 16-1: 1993 and ANSI C63.4: 1992. For measurements, a remotely controlled flush-mount metal-top turntable is used to rotate the EUT a full 360 degrees. A remote controlled non-conductive antenna mast is used to scan the antenna height from one to four meters.

This site is on file with the FCC.

The Industry Canada file number for this site is IC 2077.

3 CONDUCTED RF POWER

FCC §2.1046, IC RSS-129 §7.1 and §9.1, IC RSS-133 §6.2

3.1 Test Procedure

The transmitter output was connected to a calibrated coaxial attenuator, the other end of which was connected to a power meter. Transmitter output was read off the power meter in dBm. The power output at the transmitter antenna port was determined by adding the value of the attenuator to the power meter reading.

Tests were performed at three frequencies (low, middle, and high channels) and on the highest power levels, which can be setup on the transmitters.

3.2 Test Equipment

Description	Manufacturer	Model Number	Serial Number	Calibration due date
Power meter	HP	436A	1803A04471	3/23/03
Power sensor	HP	8481A	2652A15356	3/23/03
Attenuator	Weinschel	2 (10 dB)	BK2313	5/6/03

3.3 Test Results

The Dual Band Tri-mode CDMA Cellular Phone met the RF power output requirements of FCC Part 22 Subpart H, FCC Part 24 Subpart E, IC RSS-129 §7.1 and §9.1, and IC RSS-133 §6.2. The test results are located in Table 3-1 and Table 3-2.

Table 3-1 Conducted RF Power

EUT Mode	Frequency MHz	Channel	Measured Power dBm
AMPS	824.04	991	26.50
	836.49	383	26.50
	848.97	799	26.40
CDMA800	824.70	1013	23.80
	836.52	384	23.80
	848.31	777	23.80
CDMA1900	1851.25	25	23.70
	1880.00	600	23.90
	1908.75	1175	23.80

Table 3-2 RF Power Variation with temperature

EUT Mode	Frequency MHz	Channel	Measured Power dBm		
			+60°C	+20°C	-30°C
AMPS	824.04	991	26.3	26.50	26.2
	836.49	383	26.2	26.50	26.6
	848.97	799	26.3	26.40	26.6
CDMA800	824.70	1013	23.5	23.80	23.4
	836.52	384	23.3	23.80	23.7
	848.31	777	23.4	23.80	23.9
CDMA1900	1850.20	25	23.6	23.70	23.4
	1880.00	600	23.7	23.90	23.6
	1909.80	1175	23.8	23.80	23.9

4 RADIATED RF POWER

FCC §22.913 and IC RSS-129 §7.1 and §9.1: The Effective Radiated Power (ERP) of mobile transmitters and auxiliary test transmitters must not exceed 7 Watts.

FCC §24.232 and IC RSS-133 §6.2: The equivalent Isotropic Radiated Power (EIRP) must not exceed 2 Watts.

4.1 Test Procedure

The EUT was placed on a non-conductive turntable with the earpiece attached. The earpiece was extended vertically above the EUT using a non-conductive support. The radiated emission at the fundamental frequency was measured at 3m with a test antenna and EMI receiver.

During the measurement of the EUT, the receiver resolution bandwidth was set to 3 MHz and the average bandwidth was set to 10 kHz. These settings matched the power readings of a power meter with a thermocouple power sensor. The highest emission was recorded with the rotation of the turntable and the raising and lowering of the test antenna. The receiver reading was recorded and the field strength (E in dBμV/m) was calculated.

ERP in frequency band 824-849 MHz, and EIRP in frequency band 1851.25-1910 MHz were measured using a substitution method. The EUT was replaced by half-wave dipole (824-849 MHz) or horn antenna (1851.25-1910 MHz) connected to a signal generator, which was set to approximately -10 dBm. The spectrum analyzer reading was recorded and ERP/EIRP was calculated as follows:

$$ERP = E_1 - E_2 + V_g$$

$$EIRP = E_1 - E_2 + V_g + G$$

where,

E_1 is the receiver reading in dBμV/m when measuring the field strength of the EUT

E_2 is the receiver reading in dBμV/m when measured field strength from the generator

V_g is the generator output in dBm

G is the gain of the transmitting antenna in dBi.

4.2 Test Equipment

Description	Manufacturer	Model Number	Serial Number	Calibration due date
Power meter	HP	436A	1803A04471	3/23/03
Power sensor	HP	8481A	2652A15356	3/23/03
Signal Generator	HP	83620B	3722A00537	2/11/03
Dipole Antenna	CDI	A100	R4	9/16/03
Horn Antenna	A.H. Systems	SAS-200/571	246	1/13/03
Receive Antenna	Schaffner-Chase	CBL6112B	2622	8/26/03
EMI Receiver	HP	8546A	3410A00173/ 3448A00203	3/28/03
Attenuator	Weinschel	2 (10dB)	BK2313	5/6/03

Intertek Testing Services

4.3 Test Results

The Dual Band Tri-mode CDMA Cellular Phone met the radiated power requirements of FCC §22.913, FCC §24.232, IC RSS-129 §7.1 and §9.1, and IC RSS-133 §6.2. The test results are located in Table 4-1.

Table 4-1 Radiated RF Power

EUT Mode	Measurement Method	Frequency MHz	Channel	Measured Power dBm
AMPS	ERP	824.04	991	24.4
	ERP	836.49	383	25.4
	ERP	848.97	799	26.3
CDMA800	ERP	824.70	1013	22.0
	ERP	836.52	384	22.8
	ERP	848.31	777	23.4
CDMA1900	EIRP	1851.25	25	20.0
	EIRP	1880.00	600	21.8
	EIRP	1908.75	1175	21.9

5 MODULATION DEVIATION LIMITING

FCC §2.1047, FCC §22.915(b)(c), RSS-129 §5.9, and §6.1

Digital Modulation Techniques

Cdma2000, 1XRTT Mode uses Binary Phase Shift Keying (BPSK) modulation with a pilot.
CdmaOne (IS-95) Mode uses Offset Quadrature Phase Shift Keying (OQPSK).

5.1 Test Procedure

The RF output of the transceiver was connected to the input of a modulation analyzer through sufficient attenuation so as not to overload the meter or distort the readings. The multifunction synthesizer (audio generator) was configured as an audio signal generator and was coupled into the external microphone jack of the transceiver, or alternatively, the microphone element was removed and the generator output was connected to the microphone wires by clip leads.

At three different modulating frequencies, the output level of the audio generator was varied from -30 to +30 dB in reference to the level required to generate 8kHz deviation at 1kHz. The dynamic signal analyzer was setup record the modulation output of the EUT.

The compander was enabled for this test.

5.2 Test Equipment

Description	Manufacturer	Model Number	Serial Number	Calibration due date
Modulation Analyzer	HP	8901A	2026A00875	11/30/03
Dynamic Signal Analyzer	HP	3562A	2798A02846	5/8/03
Multifunction Synthesizer	HP	8904A	2942A02980	8/1/03
Attenuator	Weinschel	2 (10dB)	BK2313	5/6/03

5.3 Test Results

The deviation is not to exceed 12 kHz. The Dual Band Tri-mode CDMA Cellular Phone met the modulation deviation limiting requirements of FCC §22.915(b)(c), and IC RSS-129 §5.9, and §6.1. The test results are located in Figure 5-1. The audio input level to achieve 8 kHz deviation with at 1 kHz was 315 mV.

Intertek Testing Services

Figure 5-1: Modulation Deviation Limiting – Voice

Manufacturer: Sony Ericsson
EUT: T608 (S/N: UA2020P5R8)
FCCID: PXITR-CA0802
IC: 4170A-CA0802

Modulation Limiting: Voice

Tested by: Jeffrey D. Hiday
Date: 11/05/2002

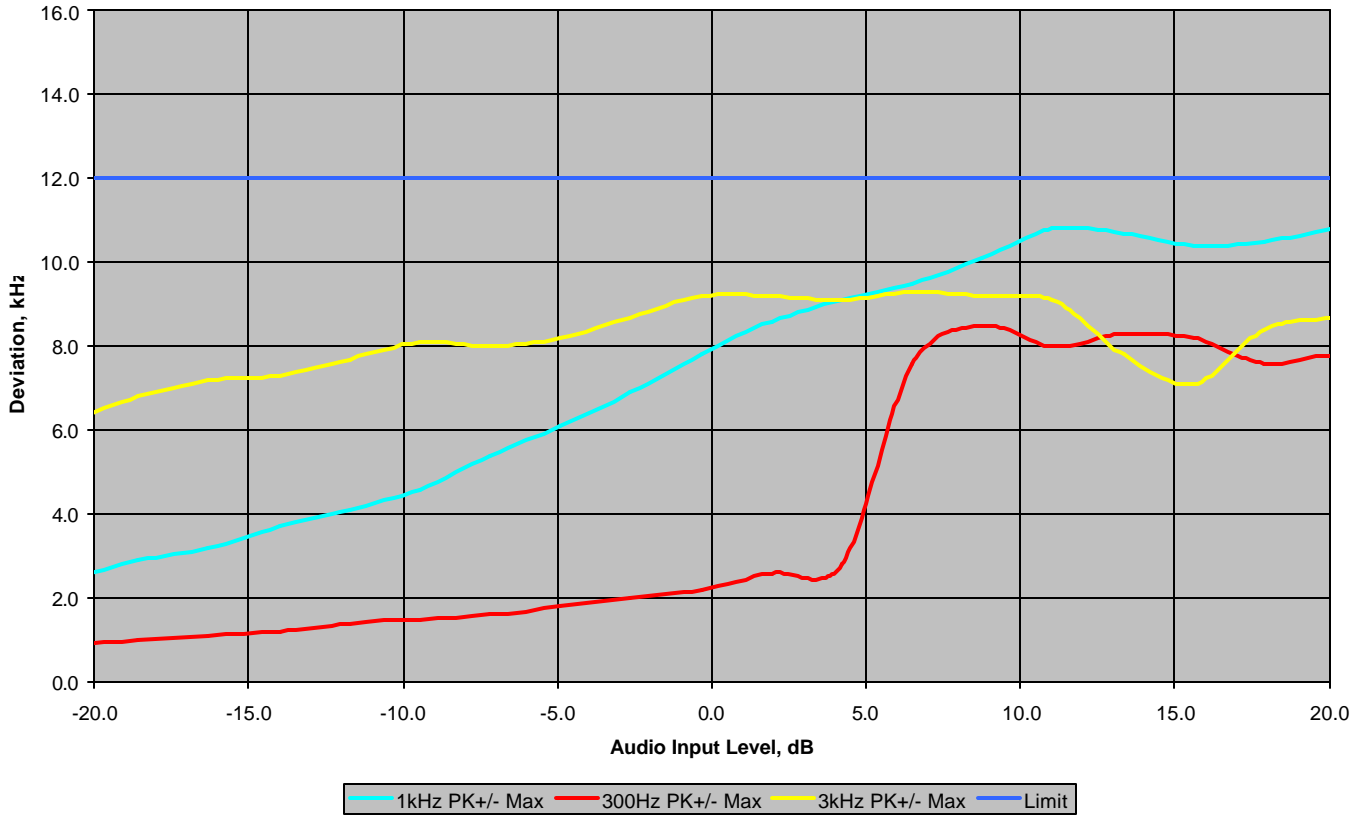
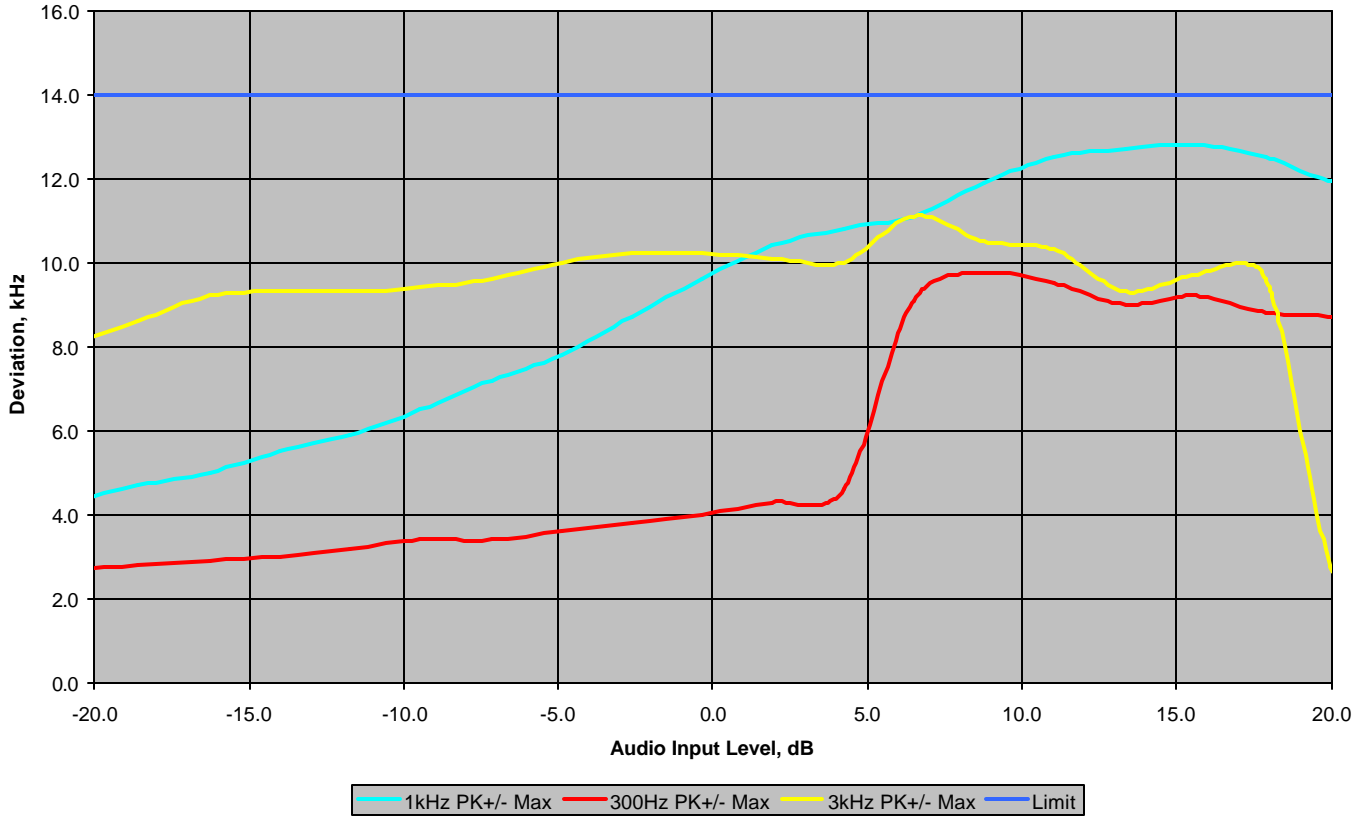

Figure 5-2: Modulation Deviation Limiting – Voice and SAT

Manufacturer: Sony Ericsson
EUT: T608 (S/N: UA2020P5R8)
FCCID: PXITR-CA0802
IC: 4170A-CA0802

Modulation Limiting: Voice and SAT

Tested by: Jeffrey D. Hiday
Date: 11/05/2002



6 AUDIO FILTER CHARACTERISTICS

CFR 47 §22.915(D), IC RSS-129 §6.2

6.1 Test Procedure

The RF output of the transceiver was connected to the input of a modulation analyzer through sufficient attenuation so as not to overload the meter or distort the readings. A multifunction synthesizer (audio signal generator) was coupled into the external microphone jack of the transceiver, or alternatively, the microphone element was removed and the generator output was connected to the microphone wires by clip leads.

The test was performed according to the block diagram shown below.

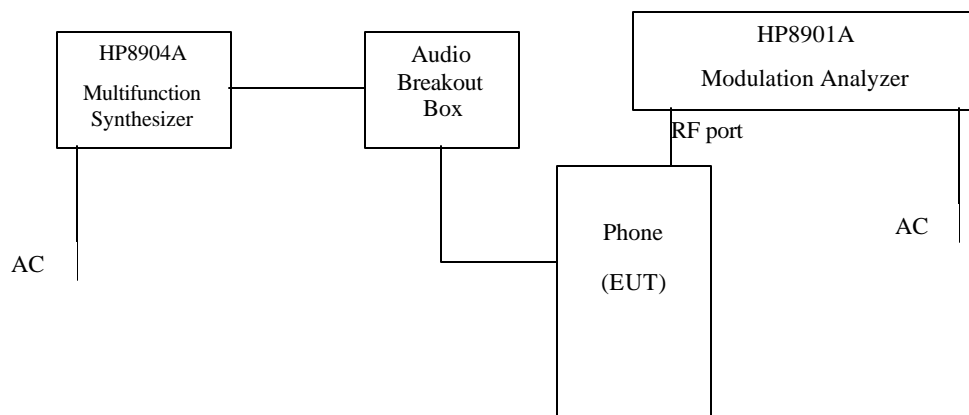

Audio Filter Characteristics

Operate the transmitter with the compander disabled, and monitor the output with a deviation meter without standard 750 microsecond de-emphasis, and without C-message weighted filter. Apply a sine wave audio input to the transmitter external audio input port, vary the modulating frequency from 300 to 3000 Hz, and observe the input levels necessary to maintain a constant ± 2.9 kHz system deviation.

From 300 to 3000 Hz the audio frequency response shall not vary more than +1 to -3 dB from a true 6 dB/octave pre-emphasis characteristic referred to the 1000 Hz level (with the exception of a permissible 6 dB/octave roll-off from 2500 to 3000 Hz).

Post Limiter Attenuation

Adjust the audio input frequency to 1000 Hz, and adjust the input level to 20 dB greater than that required to produce ± 8 kHz deviation. Note the output level on the frequency deviation meter. Using this output as reference (0 dB), vary the modulating frequency from 3000 Hz to 30,000 Hz, and observe the change in output while maintaining a constant audio input level.

For mobile stations, these signals must be attenuated, relative to the level at 1 kHz, as follows:

- In the frequency ranges of 3.0 to 5.9 kHz and 6.1 to 15.0 kHz, signals must be attenuated by at least $40 \log(f/3)$ dB, where f is the frequency of the signal in kHz.
- In the frequency range of 5.9 to 6.1 kHz, signals must be attenuated at least 35 dB.
- In the frequency range above 15 kHz, signals must be attenuated at least 28 dB.

6.2 Test Equipment

Description	Manufacturer	Model Number	Serial Number	Calibration due date
Modulation Analyzer	HP	8901A	2026A00875	11/30/03
Dynamic Signal Analyzer	HP	3562A	2798A02846	5/8/03
Multifunction Synthesizer	HP	8904A	2942A02980	8/1/03
Attenuator	Weinschel	2 (10dB)	BK2313	5/6/03

6.3 Test Results

The Dual Band Tri-mode CDMA Cellular Phone met the audio response characteristic requirements of FCC §22.915(d) and IC RSS-129 §6.2. The test results are located in Figure 6-1.

Figure 6-1: Audio Filter Characteristics

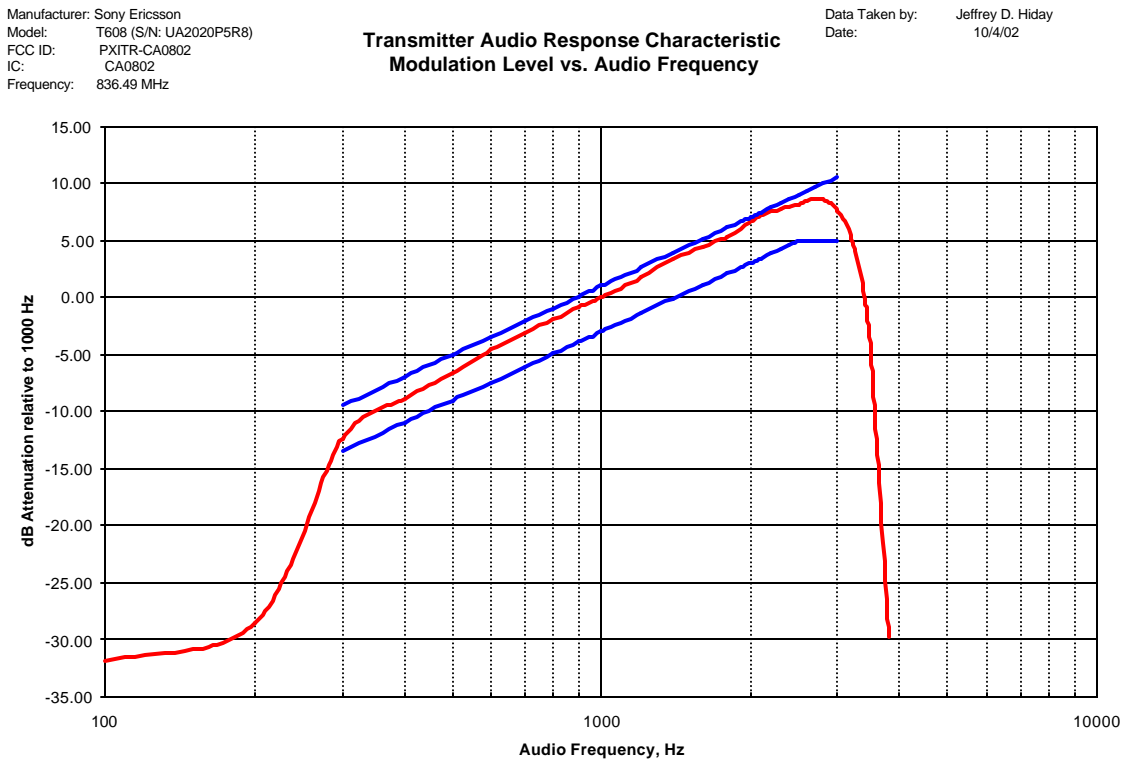
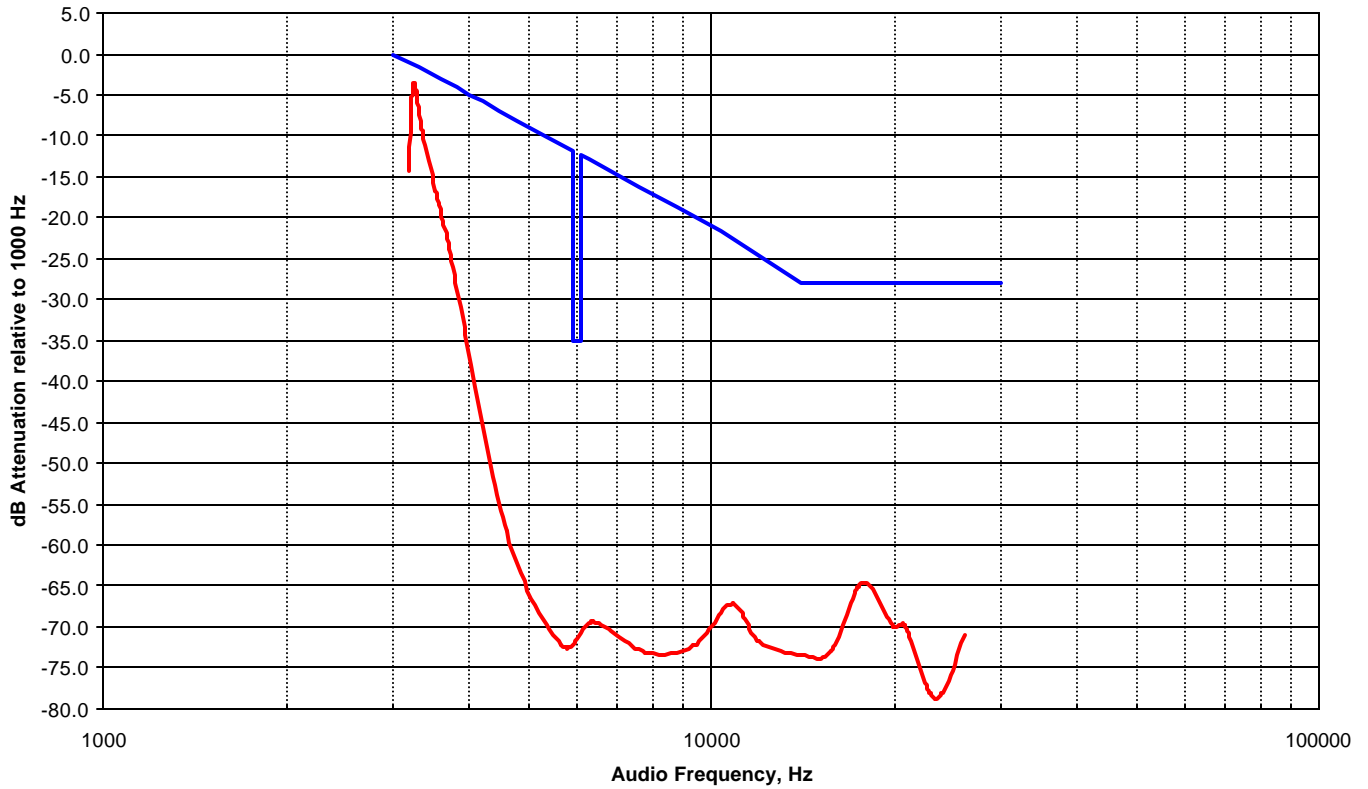

Figure 6-2: Post Limiter Filter Attenuation

Manufacturer: Sony Ericsson
Model: T608 (S/N: UA2020P5R8)
FCC ID: PXITR-CA0802
IC: CA0802
Frequency: 836.49 MHz

Data Taken by: Jeffrey D. Hiday
Date: 10/4/02

**Transmitter Audio Response Characteristic
Modulation Level vs. Audio Frequency**



7 EMISSION LIMITATIONS, OCCUPIED BANDWIDTH

CFR 47 §2.1049, §22.917(b)(d), IC RSS-129 §6.3 and §8.1

For F3E/F3D emission mask uses with audio filter, the mean power of emissions must be attenuated below the mean power of the unmodulated carrier wave (P) as follows:

- On any frequency removed from the carrier frequency by more than 20 kHz but not more than 45 kHz: at least 26 dB;
- On any frequency removed from the carrier frequency by more than 45 kHz, up to the first multiple of the carrier frequency: at least 60 dB or $43 + 10 \log P$ dB, whichever is the lesser attenuation.

For F1D emission mask, the mean power of emissions must be attenuated below the mean power of the unmodulated carrier (P) as follows:

- On any frequency removed from the carrier frequency by more than 20 kHz but no more than 45 kHz: at least 26 dB;
- On any frequency removed from the carrier frequency by more than 45 kHz but not more than 90 kHz: at least 45 dB;
- On any frequency removed from the carrier frequency by more than 90 kHz, up to the first multiple of the carrier frequency: at least 60 dB or $43 + 10 \log P$ dB, whichever is the lesser attenuation.

7.1 Test Procedure

The RF output of the transceiver was connected to the input of the spectrum analyzer through sufficient attenuation. The audio generator was connected to the audio input of the transceiver.

The spectrum with no modulation was recorded. The audio input signal was adjusted to obtain the frequencies deviation equal 6 kHz at the audio frequency of maximum response which was determined measuring deviation versus frequency from 300 Hz to 3.5 kHz and was found 2.8 kHz. The audio input level was increased by 16 dB. The audio frequency was set to the frequency 2.5 kHz.

The resolution bandwidth of the spectrum analyzer was set at 300 Hz and the spectrum was recorded in the frequency band ± 100 kHz from the carrier frequency. The same plots were generated for wideband emissions, SAT, ST, DTMF9, Voice, some of the combinations of these modulating signals and in CDMA mode.

7.2 Test Equipment

Description	Manufacturer	Model Number	Serial Number	Calibration due date
Spectrum Analyzer	HP	8566B	2134A01032/ 2344A05843	12/3/02
Attenuator	Weinschel	2 (10dB)	BK2313	5/6/03

Intertek Testing Services

7.3 Test Results

The Dual Band Tri-mode CDMA Cellular Phone met the occupied bandwidth requirements of FCC §22.917(b)(d) and IC RSS-129 §6.3 and §8.1.

Table 7-1: Summary of test result locations

Location	Mode	Channel	Description
Figure 7-1	AMPS	383	Occupied Bandwidth – SAT
Figure 7-2	AMPS	383	Occupied Bandwidth – Signaling Tone
Figure 7-3	AMPS	383	Occupied bandwidth – SAT and ST
Figure 7-4	AMPS	383	Occupied bandwidth – DTMF
Figure 7-5	AMPS	383	Occupied Bandwidth – Voice
Figure 7-6	AMPS	383	Occupied Bandwidth – 10kb Wideband Data

Table 7-2: Occupied bandwidth measurements for CDMA modes

Mode	Channel	Resolution Bandwidth	Video Bandwidth	Sweep time	Measured Bandwidth MHz
CDMA800	384	30 kHz	300 kHz	500 ms	1.275
CDMA 1XRTT	384	30 kHz	300 kHz	500 ms	1.288
CDMA800	1013	30 kHz	300 kHz	500 ms	1.275
CDMA 1XRTT	1013	30 kHz	300 kHz	500 ms	1.275
CDMA800	777	30 kHz	300 kHz	500 ms	1.275
CDMA 1XRTT	777	30 kHz	300 kHz	500 ms	1.288
CDMA1900	25	30 kHz	300 kHz	500 ms	1.288
CDMA 1XRTT	25	30 kHz	300 kHz	500 ms	1.288
CDMA1900	600	30 kHz	300 kHz	500 ms	1.275
CDMA 1XRTT	600	30 kHz	300 kHz	500 ms	1.288
CDMA1900	1175	30 kHz	300 kHz	500 ms	1.288
CDMA 1XRTT	1175	30 kHz	300 kHz	500 ms	1.275

Intertek Testing Services

Figure 7-1: Occupied Bandwidth – SAT

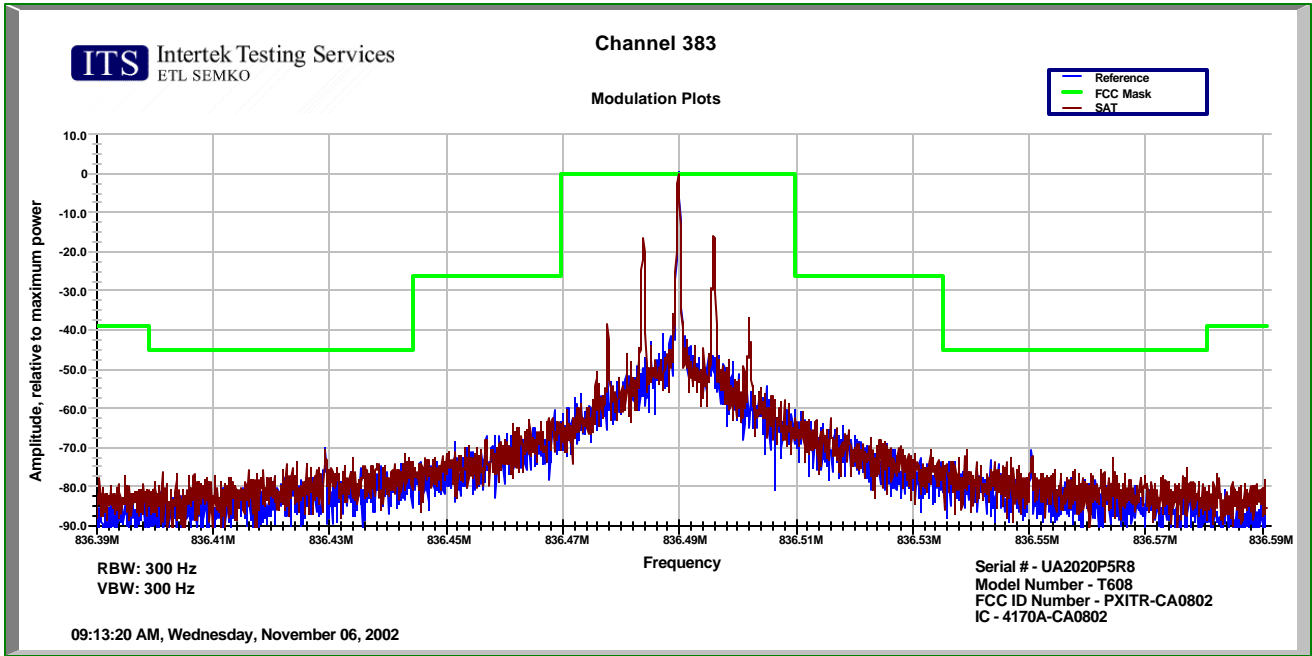
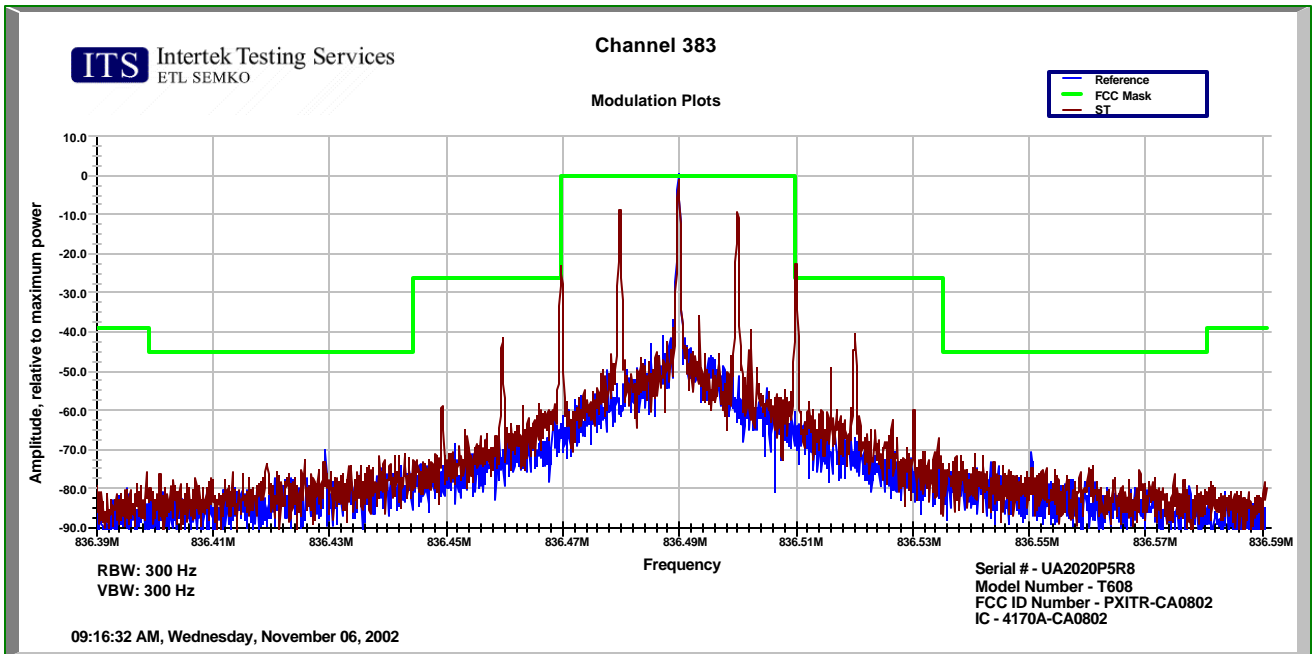

Figure 7-2: Occupied Bandwidth – Signaling Tone



Intertek Testing Services

Figure 7-3: Occupied bandwidth – SAT and ST

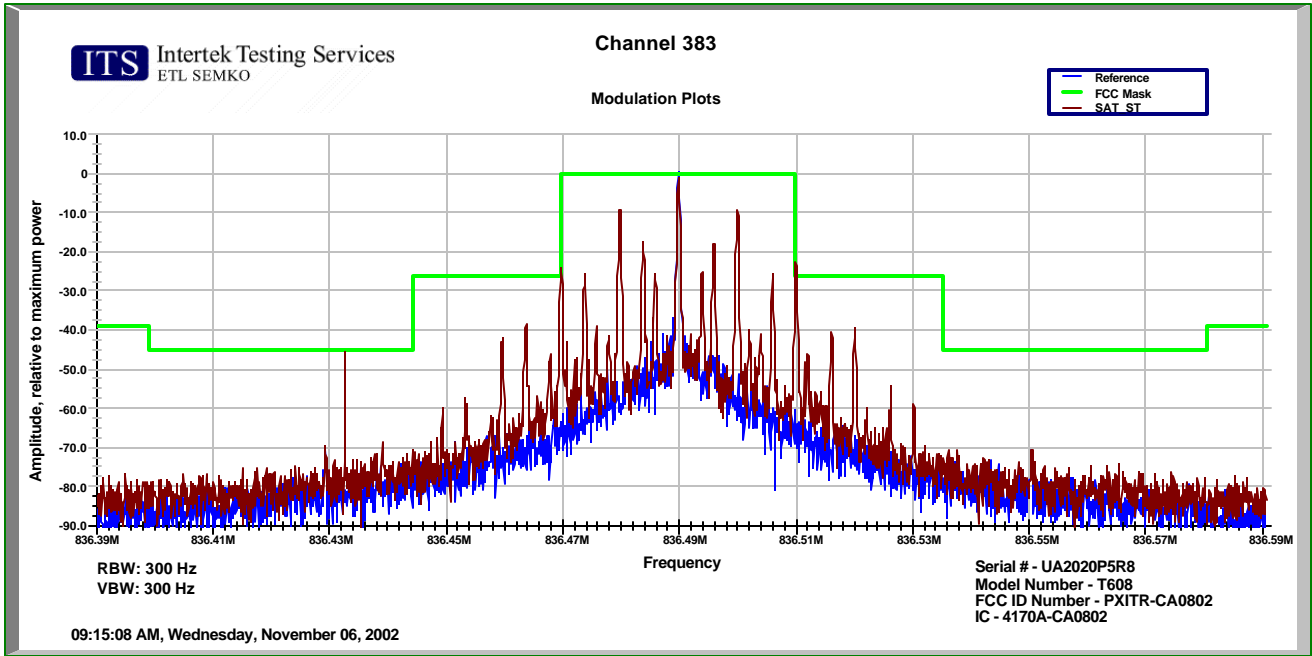
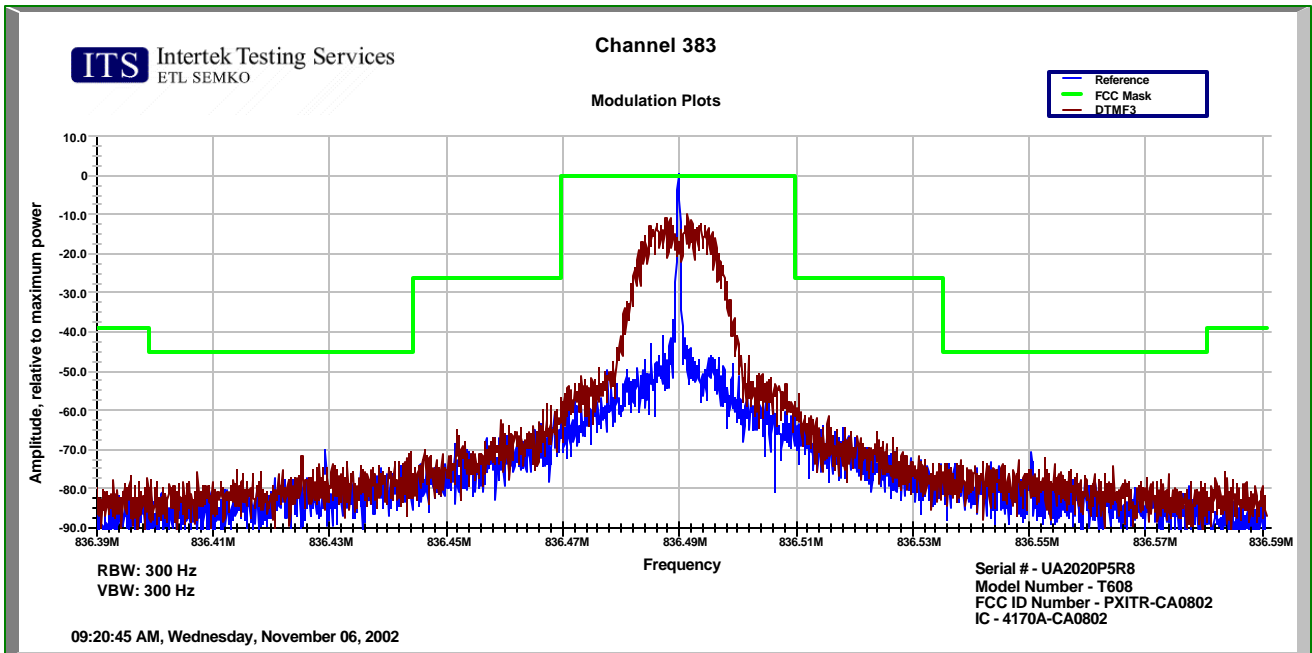

Figure 7-4: Occupied bandwidth – DTMF3



Intertek Testing Services

Figure 7-5: Occupied Bandwidth – Voice

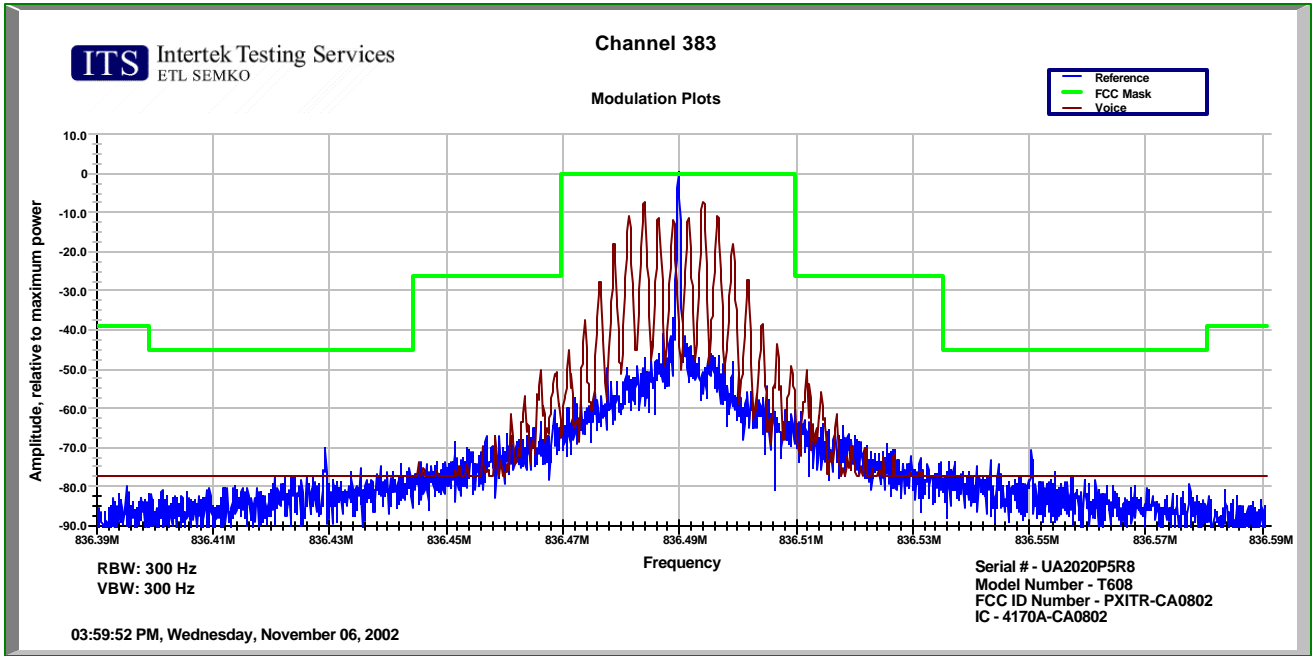
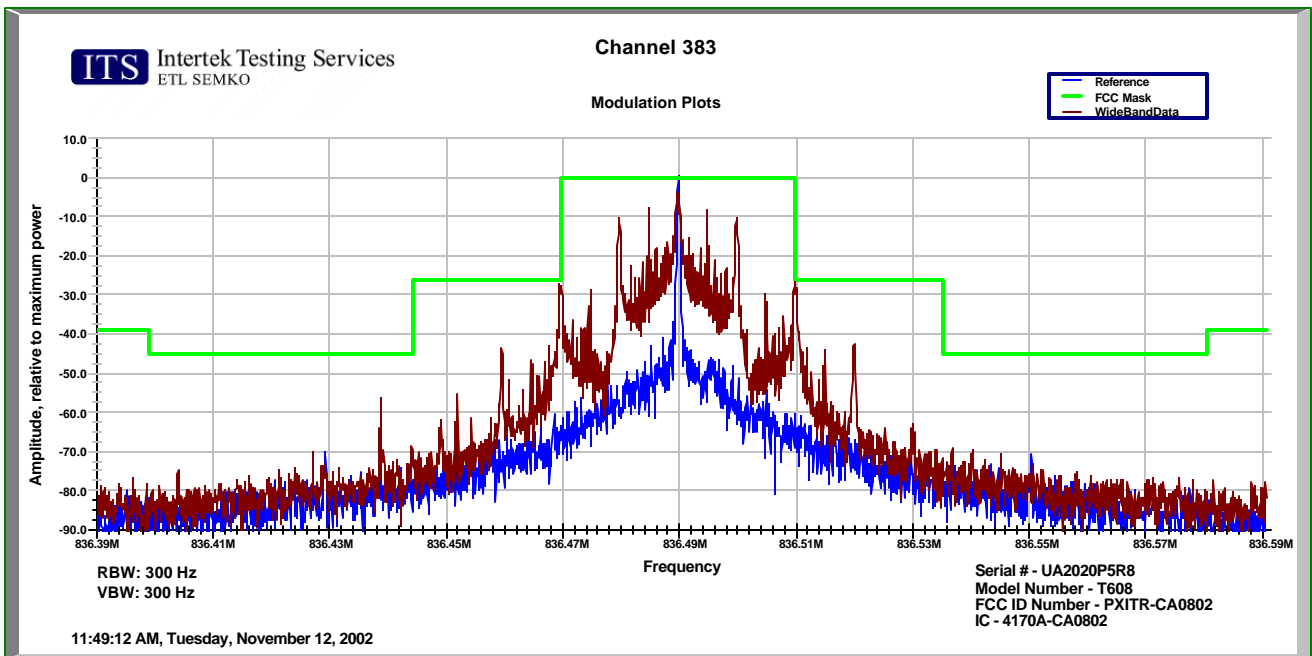

Figure 7-6: Occupied Bandwidth – 10kb Wideband Data



8 OUT OF BAND EMISSION AT ANTENNA TERMINALS

FCC §2.1047, FCC §22.917(f), FCC §24.238(a), IC RSS-129 6.3, §7.2.2, §8.1.1, and §10, and IC RSS-133 §6.3

Out of Band Emissions: The mean power of emissions must be attenuated below the mean power of the unmodulated carrier (P) on any frequency twice or more than twice the fundamental frequency by at least $43 + 10 \log P$ dB.

Mobile Emissions in Base Frequency Range: The mean power of any emissions appearing in the base station frequency range from cellular mobile transmitters operated must be attenuated to a level not to exceed -80 dBm at the transmit antenna connector.

Band Edge Requirements: In the 1 MHz bands immediately outside and adjacent to the frequency block, a resolution bandwidth of at least 1 percent of the emission bandwidth of the fundamental emission of the transmitter may be employed to measure the Out of Band Emissions.

8.1 Test Procedure

The RF output of the transceiver was connected to a spectrum analyzer through appropriate attenuation. The resolution bandwidth of the spectrum analyzer was set at 1 MHz. The audio modulating signal was adjusted like it is described in Section 6.1 of this report. Sufficient scans were taken to show the out of band Emissions if any up to 10th harmonic.

8.2 Test Equipment

Description	Manufacturer	Model Number	Serial Number	Calibration due date
Spectrum Analyzer	HP	8566B	2134A01032/ 2344A05843	12/3/02
Highpass Filter	FILTEK	HP12/1000-5AB	ITS213156	5/6/03
Highpass Filter	FILTEK	HP12/2000-5AB	ITS213156	5/6/03
Attenuator	Weinschel	2 (10dB)	BK2313	5/6/03

8.3 Test Results

The Dual Band Tri-mode CDMA Cellular Phone met the out of band emission at antenna terminal requirements of FCC §22.917(f), FCC §24.238(a), IC RSS-129 6.3, §7.2.2, §8.1.1, and §10, and IC RSS-133 §6.3.

Table 8-1: Summary of test result locations

Location	Mode (Band)	Channel	Description
Figure 8-1	AMPS	383	Conducted spurious emissions, 30MHz to 10 GHz
Figure 8-2	AMPS	799	Conducted spurious emissions, 30MHz to 10 GHz
Figure 8-3	AMPS	991	Conducted spurious emissions, 30MHz to 10 GHz
Figure 8-4	CDMA800	384	Conducted spurious emissions, 30MHz to 10 GHz
Figure 8-5	CDMA800	777	Conducted spurious emissions, 30MHz to 10 GHz
Figure 8-6	CDMA800	1013	Conducted spurious emissions, 30MHz to 10 GHz
Figure 8-7	CDMA1900	25	Conducted spurious emissions, 30MHz to 20 GHz
Figure 8-8	CDMA1900	600	Conducted spurious emissions, 30MHz to 20 GHz
Figure 8-9	CDMA1900	1175	Conducted spurious emissions, 30MHz to 20 GHz
Figure 8-10	AMPS	383, 799, 991	Emissions in base frequency range, 869 to 894 MHz
Figure 8-11	CDMA800	384, 777, 1013	Emissions in base frequency range, 869 to 894 MHz
Figure 8-12	CDMA800	1013	Emissions within 1 MHz of band edge
Figure 8-13	CDMA800	777	Emissions within 1 MHz of band edge
Figure 8-14	CDMA1900	25	Emissions within 1 MHz of band edge
Figure 8-15	CDMA1900	1175	Emissions within 1 MHz of band edge

Figure 8-1: Out of band emissions at antenna terminals – AMPS Channel 383

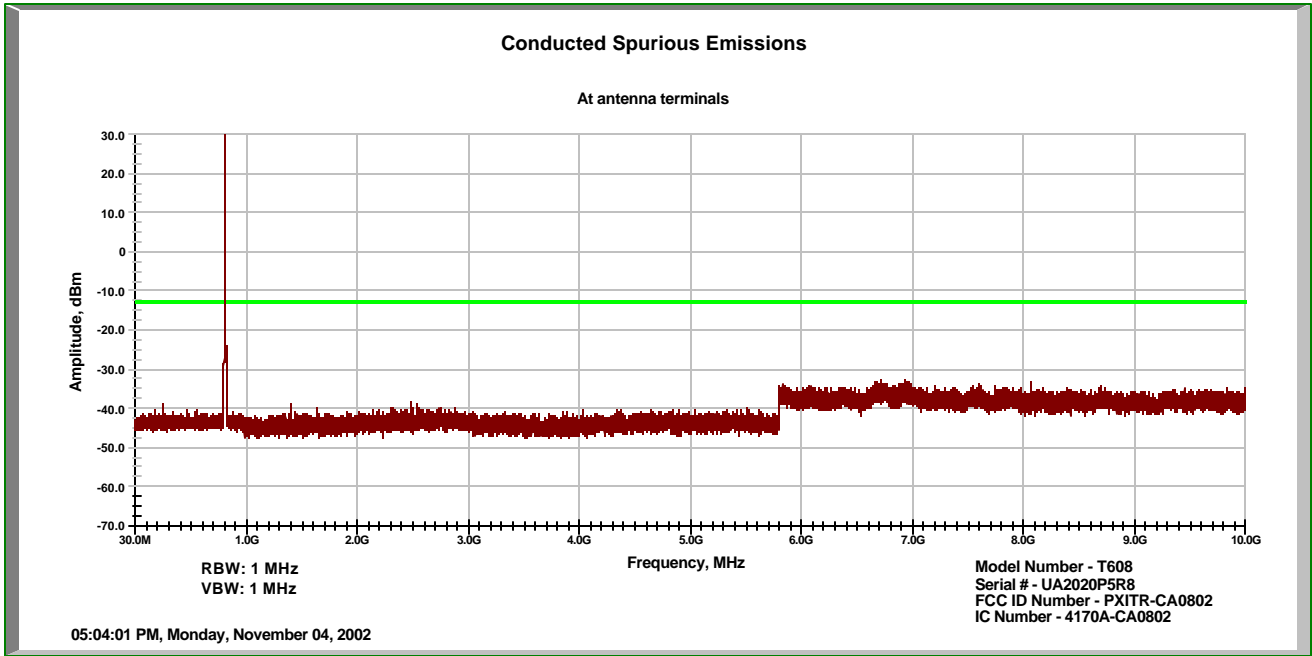

Figure 8-2: Out of band emissions at antenna terminals – AMPS Channel 799

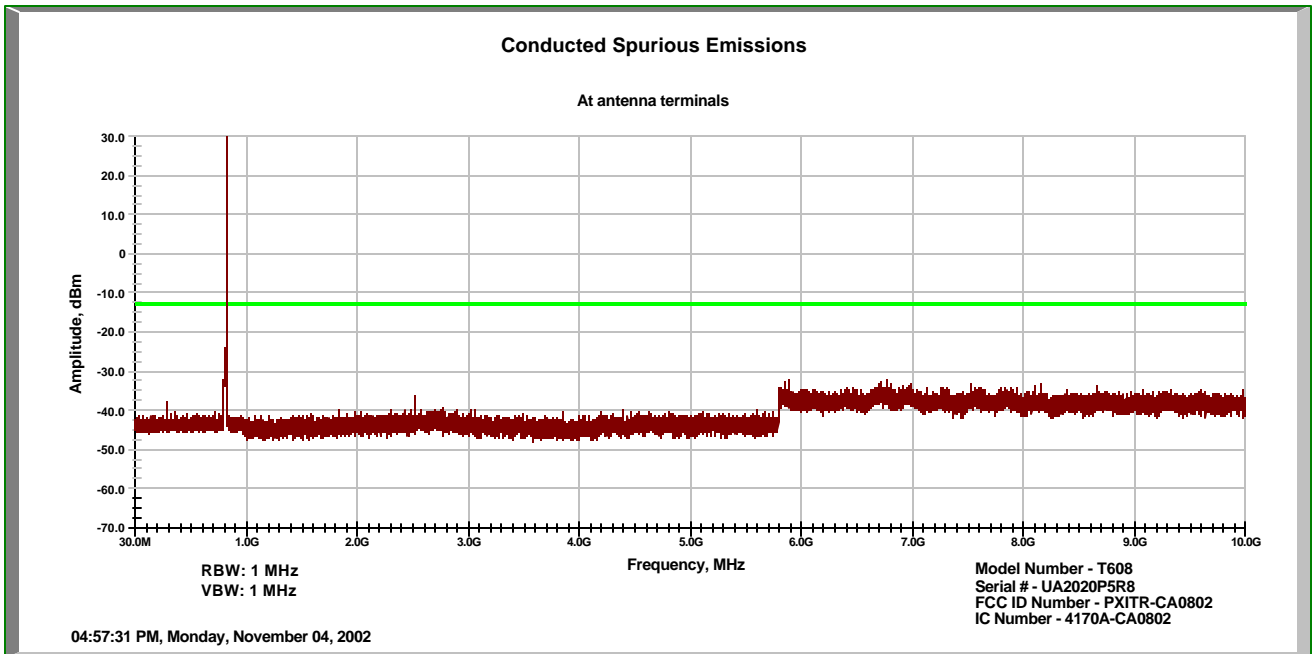

Figure 8-3: Out of band emissions at antenna terminals – AMPS Channel 991

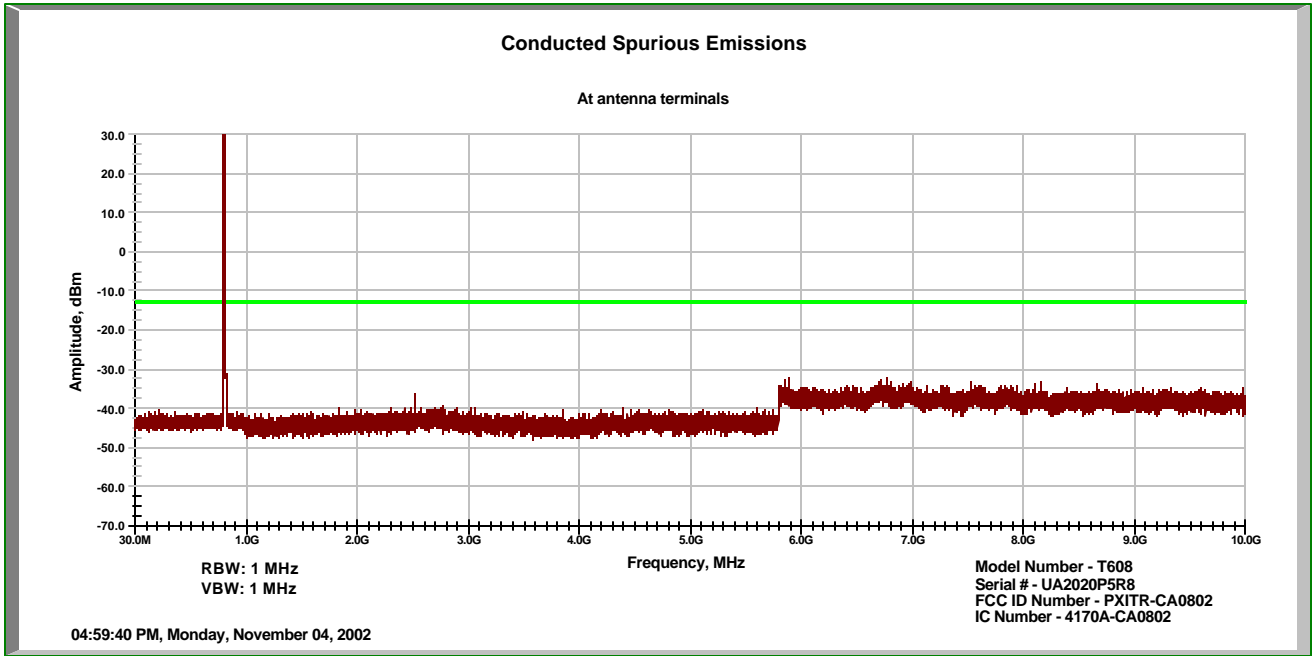

Figure 8-4: Out of band emissions at antenna terminals – CDMA800 Channel 384

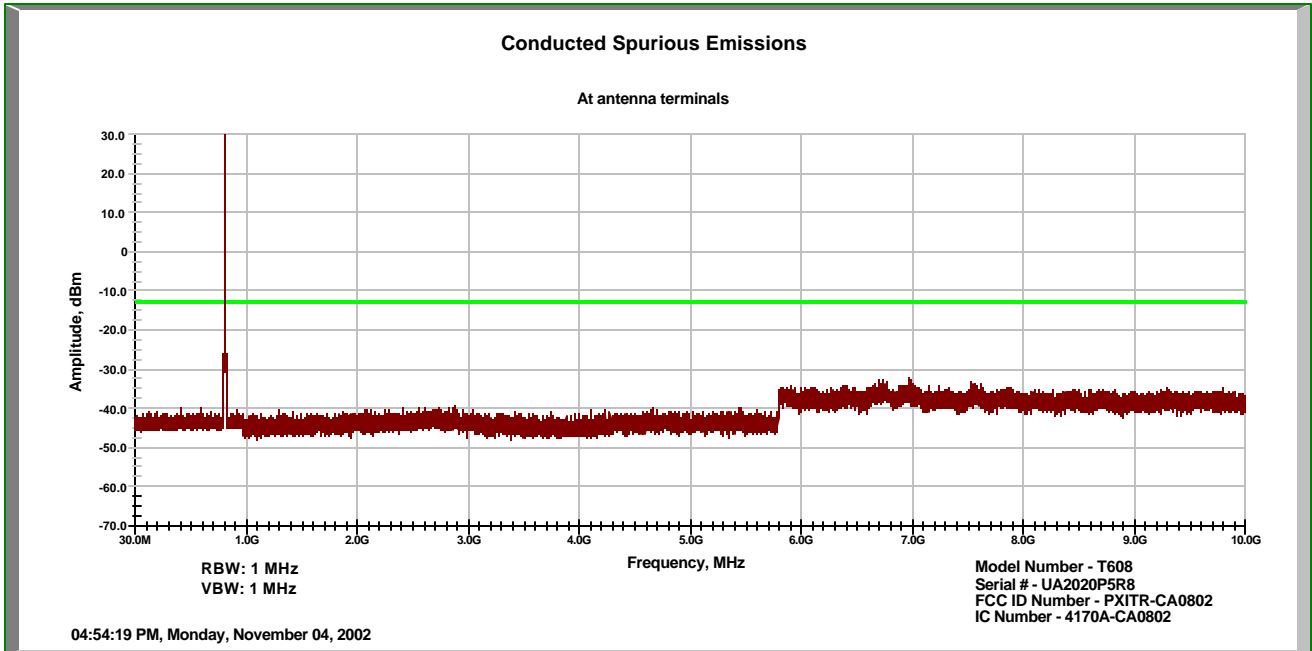

Figure 8-5: Out of band emissions at antenna terminals – CDMA800 Channel 777

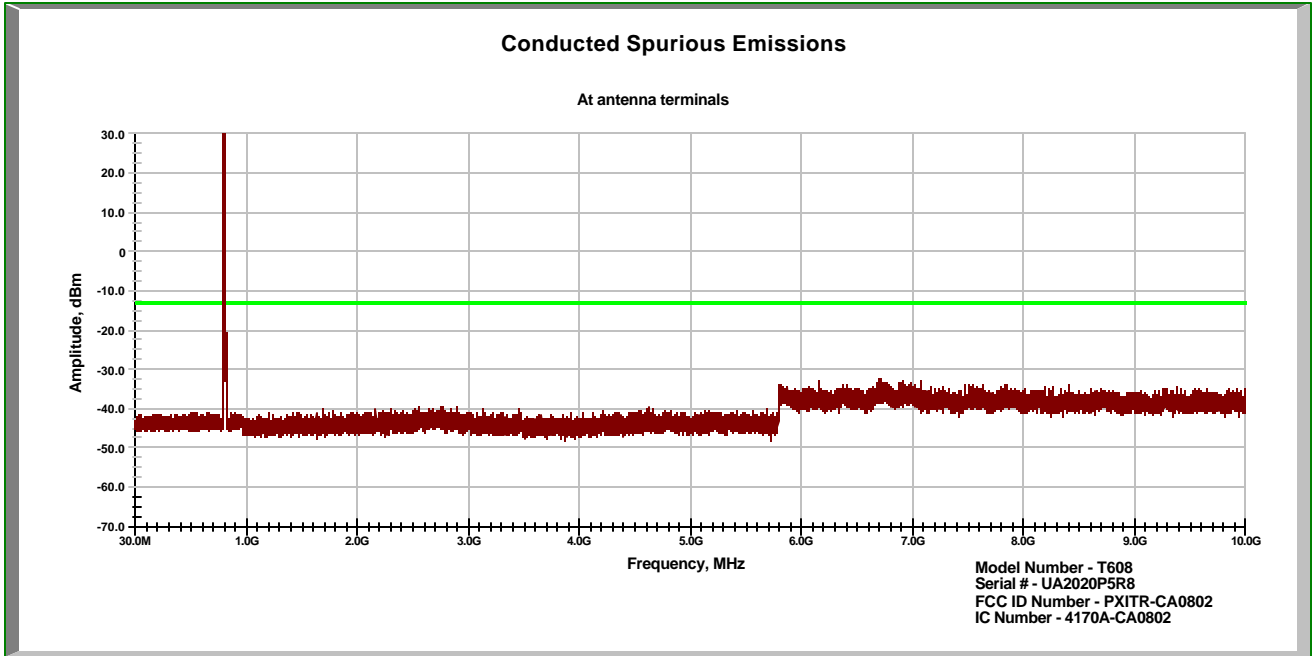

Figure 8-6: Out of band emissions at antenna terminals – CDMA800 Channel 1013

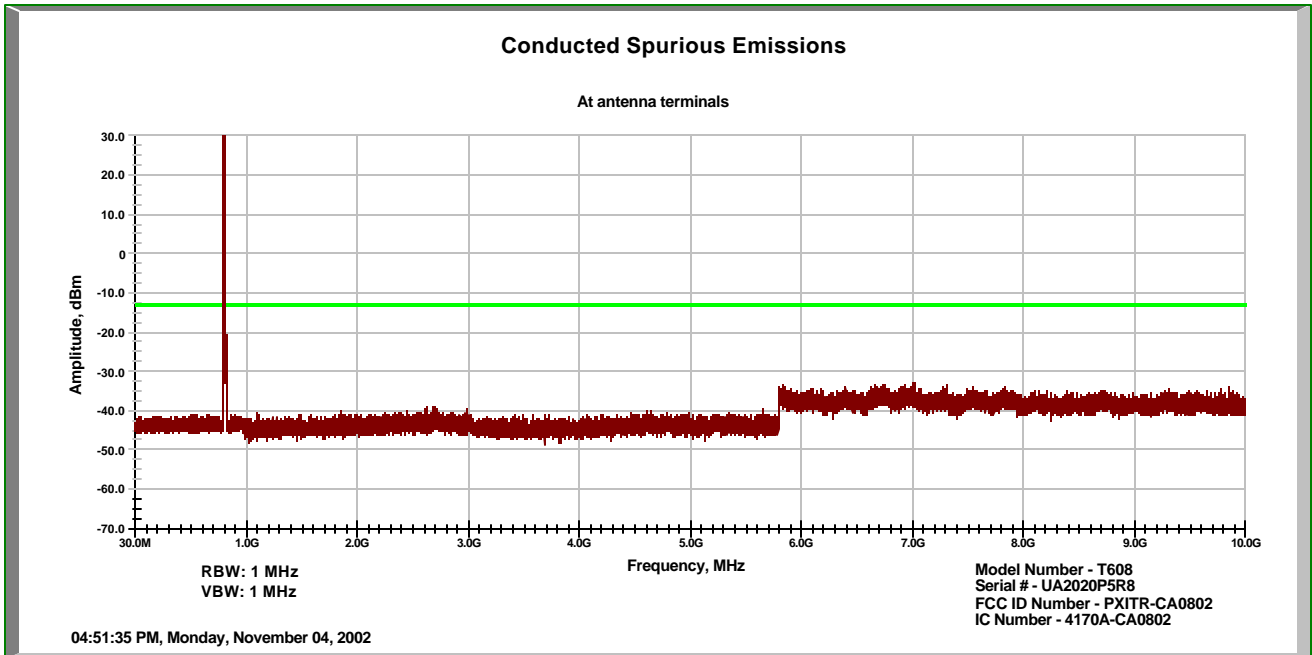

Figure 8-7: Out of band emissions at antenna terminals – CDMA1900 Channel 25

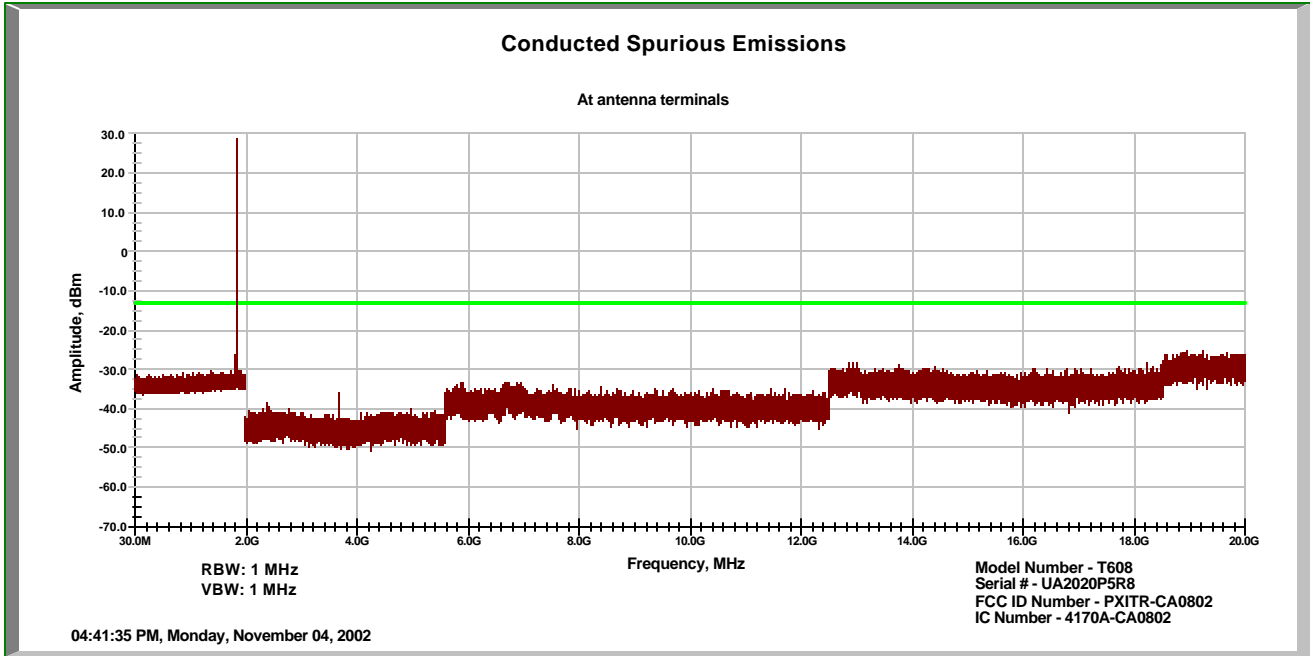

Figure 8-8: Out of band emissions at antenna terminals – CDMA800 Channel 600

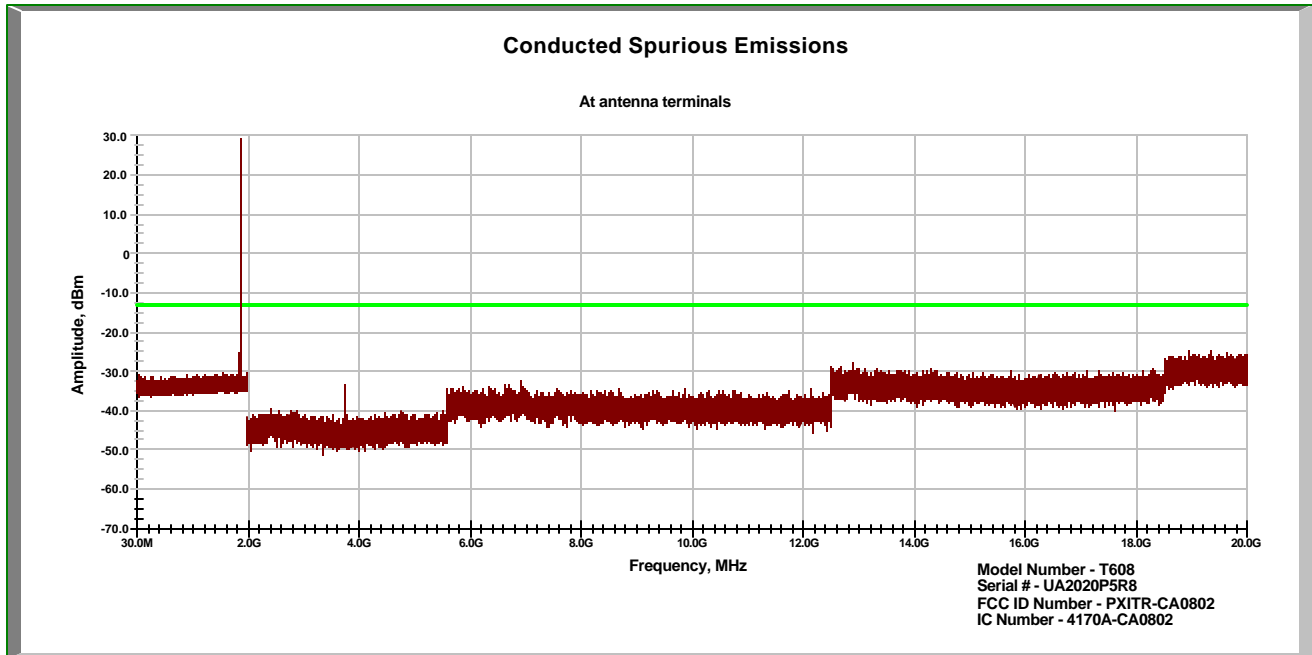

Figure 8-9: Out of band emissions at antenna terminals – CDMA1900 Channel 1175

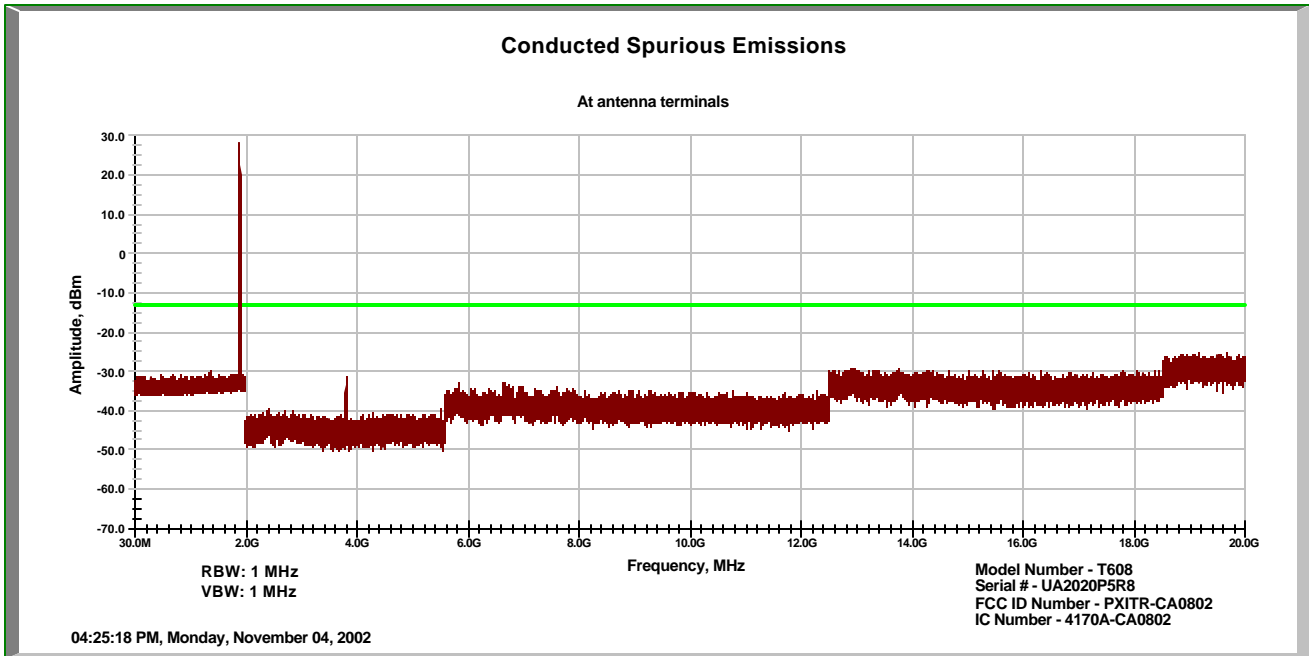

Figure 8-10: Emissions in base frequency range – AMPS Channels 383, 799, 991

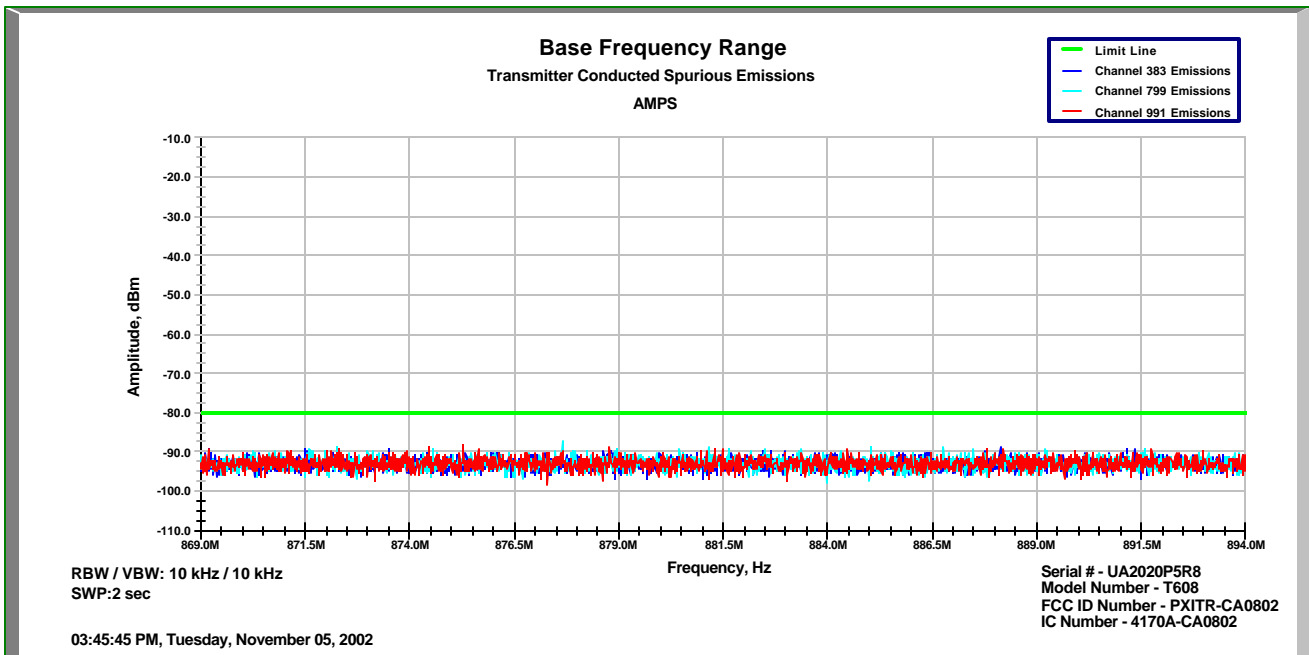

Figure 8-11: Emissions in base frequency range – CDMA800 Channels 384, 777, 1013

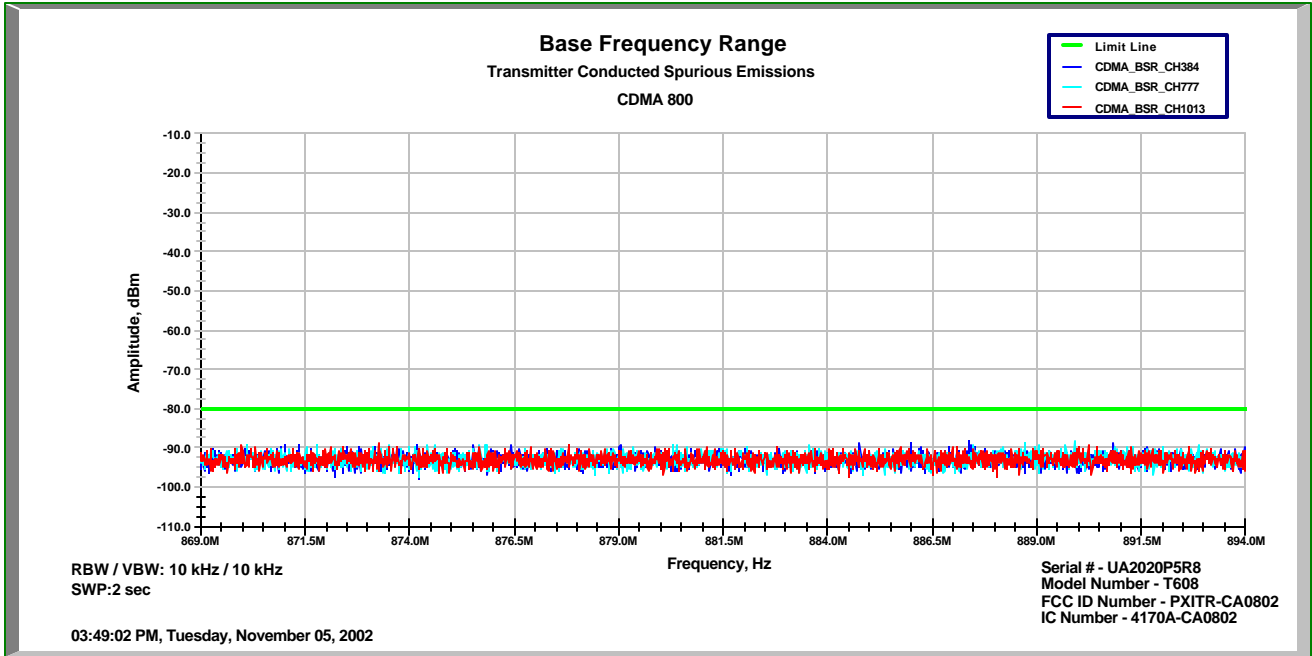

Figure 8-12: Emissions within 1 MHz of band edge, CDMA 800 Channel 1013

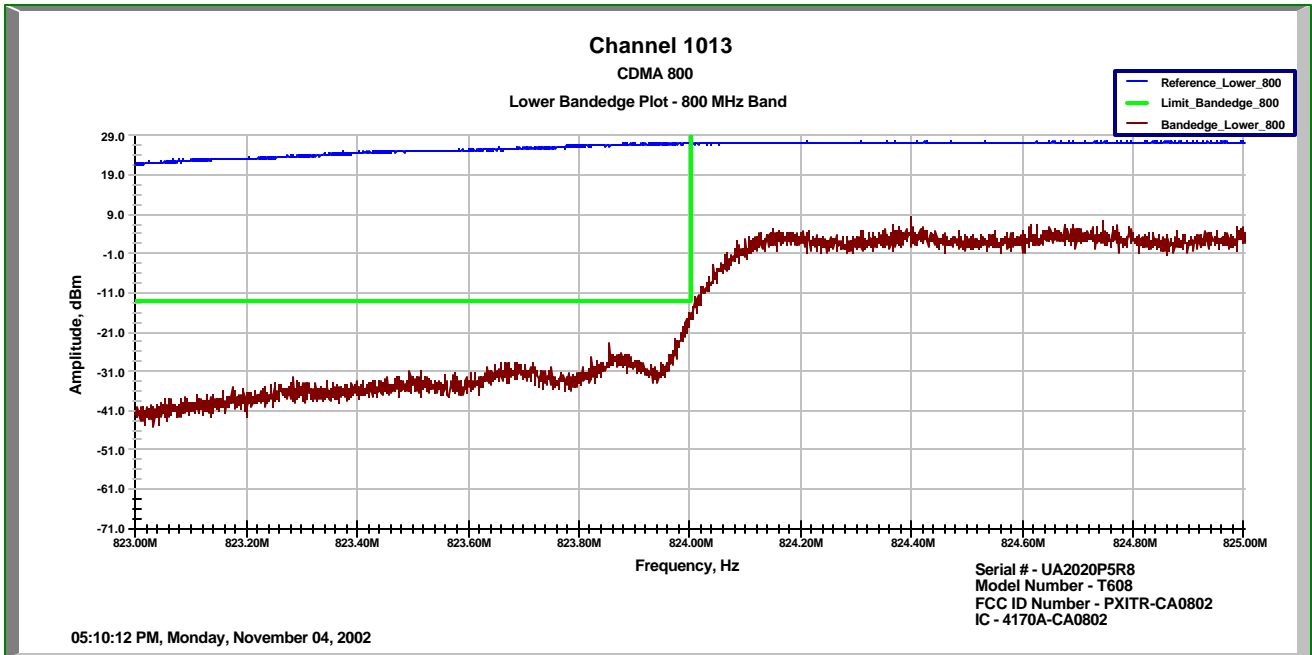

Figure 8-13: Emissions within 1 MHz of band edge, CDMA 800 Channel 777

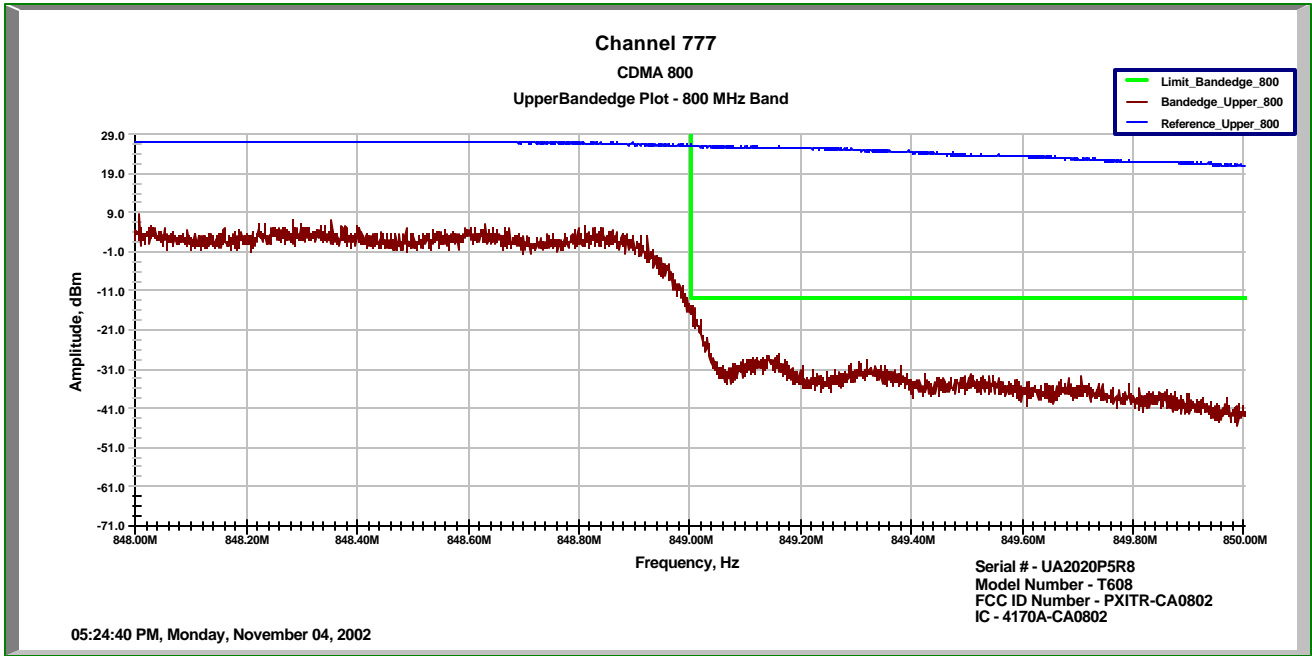

Figure 8-14: Emissions within 1 MHz of band edge, CDMA 1900 Channel 25

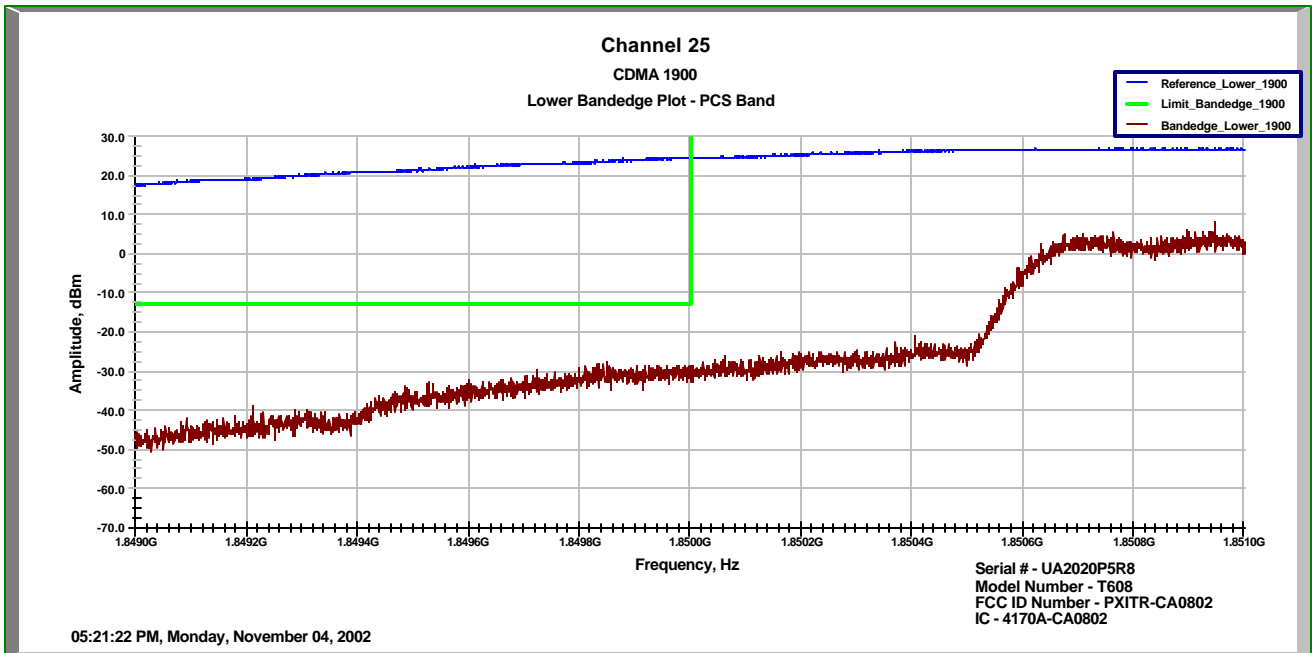
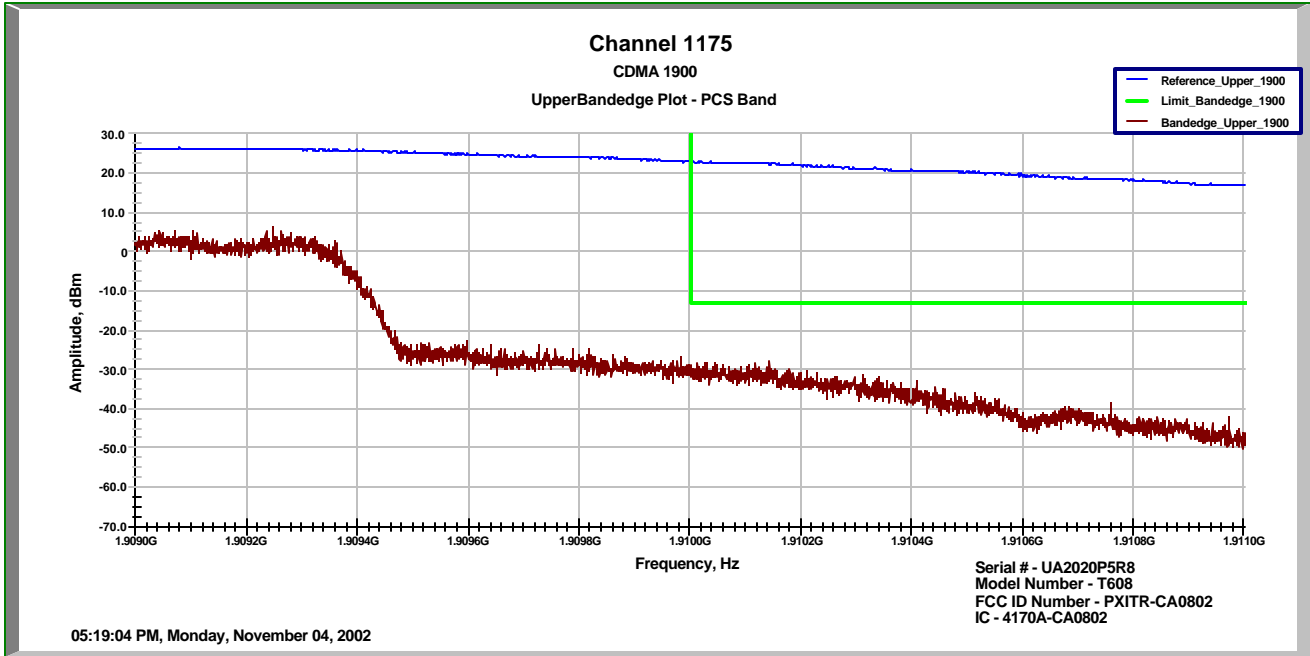

Figure 8-15: Emissions within 1 MHz of band edge, CDMA 1900 Channel 1175



9 FIELD STRENGTH OF SPURIOUS RADIATION

FCC §2.1053, IC RSS-129 §8.1

9.1 Test Procedure

The EUT was placed on a non-conductive turntable with the earpiece attached. The earpiece was extended vertically above the EUT using a non-conductive support. The measurement antenna was placed at a distance of 3 meters from the EUT. During the tests, the antenna height and EUT azimuth were varied in order to identify the maximum level of emissions from the EUT. This maximization process was repeated with the EUT positioned in each of its three orthogonal orientations.

The frequency range up to tenth harmonic was investigated for each of three fundamental frequencies (low, middle, and high channels). Once spurious emissions were identified, the power of the emission was determined using the substitution method.

The spurious emissions attenuation was calculated as the difference between radiated power at the fundamental frequency and at the spurious emissions frequency.

9.2 Test Equipment

Description	Manufacturer	Model Number	Serial Number	Calibration due date
Spectrum Analyzer	HP	8566B	2134A01032/ 2344A05843	12/3/02
Spectrum Analyzer	HP	8546A	3410A00173/ 3448A00203	3/28/03
Preamplifier	HP	8447D	2648A04926	2/22/03
Preamplifier	HP	8449B	3008A00989	10/29/03
Antenna	Schaffner-Chase	CBL6112B	2622	8/26/03
High pass Filter	FILTEK	HP12/1000-5AB	ITS213156	5/6/03
High pass Filter	FILTEK	HP12/2000-5AB	ITS213156	5/6/03
Receiving Biconilog Antenna	Chase	CBL6112	2622	8/26/03
Receiving Horn Antenna	AH-Systems	SAS-200/571	246	1/13/03
Transmitting Dipole Antenna	CDI	A100	423-B4	9/16/03
Transmitting Horn Antenna	EMCO	3115	9208-3919	2/20/03

9.3 Test Results

The Dual Band Tri-mode CDMA Cellular Phone met the field strength of spurious radiation requirements of FCC §2.1053 and IC RSS-129 §8.1. There were no emissions detected within 20 dB of the limit.

10 POWER LINE CONDUCTED EMISSIONS

FCC §15.107, FCC §15.207

10.1 Test Procedure

Measurements are carried out using quasi-peak and average detector receivers in accordance with CISPR 16. An AMN is required to provide a defined impedance at high frequencies across the power feed at the point of measurement of terminal voltage and also to provide isolation of the circuit under test from the ambient noise on the power lines. An AMN as defined in CISPR 16 shall be used.

The EUT is located so that the distance between the boundary of the EUT and the closest surface of the AMN is 0.8m.

Where a flexible mains cord is provided by the manufacturer, this shall be 1m long or if in excess of 1m, the excess cable is folded back and forth as far as possible so as to form a bundle not exceeding 0.4m in length.

The EUT is arranged and connected with cables terminated in accordance with the product specification.

Conducted disturbance is measured between the phase lead and the reference ground, and between the neutral lead and the reference ground. Both measured values are reported.

The EUT, where intended for tabletop use, is placed on a table whose top is 0.8m above the ground plane. A vertical, metal reference plane is placed 0.4m from the EUT. The vertical metal reference-plane is at least 2m by 2m. The EUT shall be kept at least 0.8m from any other metal surface or other ground plane not being part of the EUT. The table is constructed of non-conductive materials. Its dimensions are 1m by 1.5m, but may be extended for larger EUT.

Floor standing EUTs are placed on a horizontal metal ground plane and isolated from the ground plane by 3 to 12 mm of insulating material. The metal ground plane extends at least 0.5m beyond the boundaries of the EUT and has minimum dimensions of 2m by 2m.

Equipment setup for conducted disturbance tests followed the guidelines of ANSI C63.4: 1992.

10.2 Test Equipment

Description	Manufacturer	Model Number	Serial Number	Calibration due date
Spectrum Analyzer	HP	8566B	2134A010321/ 2344A05843	12/3/02
EMI Receiver	HP	8546A	3410A00173/ 3448A00203	3/28/03
LISN	FCC	FCC-LISN-50-50- M	2020	5/12/03

10.3 Test Results

The Dual Band Tri-mode CDMA Cellular Phone met the power line conducted emission requirements of FCC §15.107 and §15.207. The test results are located in Figure 10-1.

Intertek Testing Services

Figure 10-1: FCC §15.107 and §15.207 power line conducted emissions (peak) (CST-16)

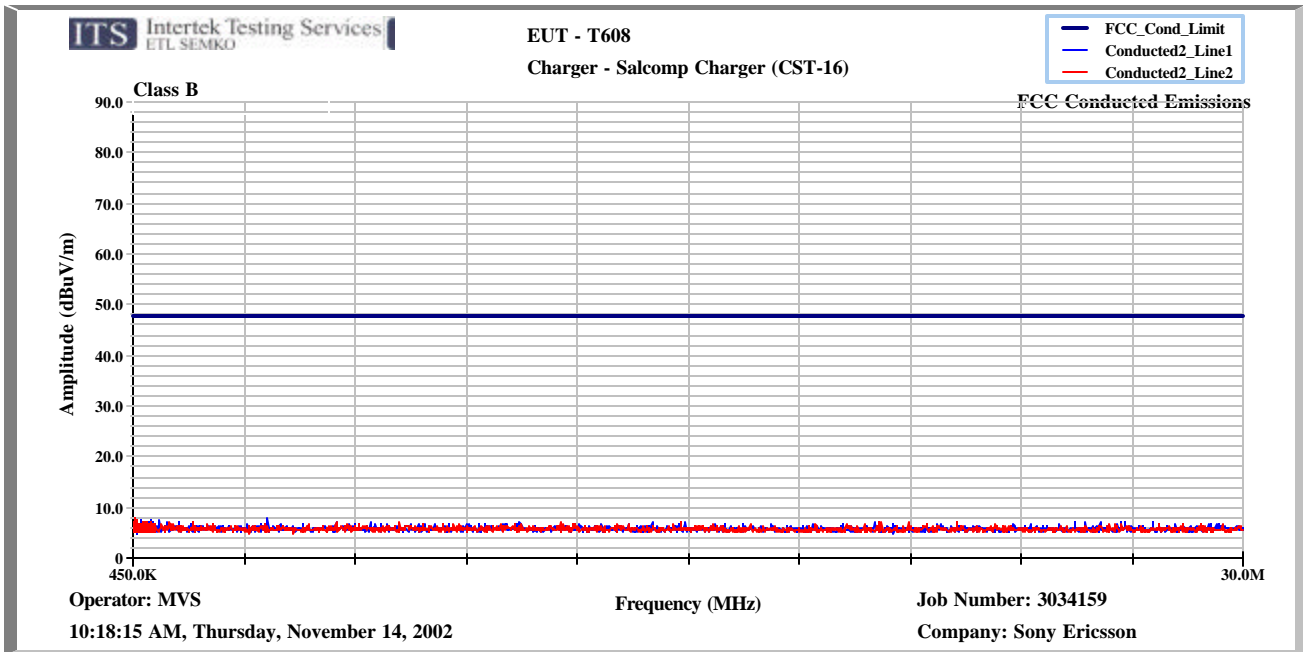

There were no emissions detected within 20 dB of the limit.

Figure 10-2: FCC §15.107 and §15.207 power line conducted emissions (peak) (CST-15)

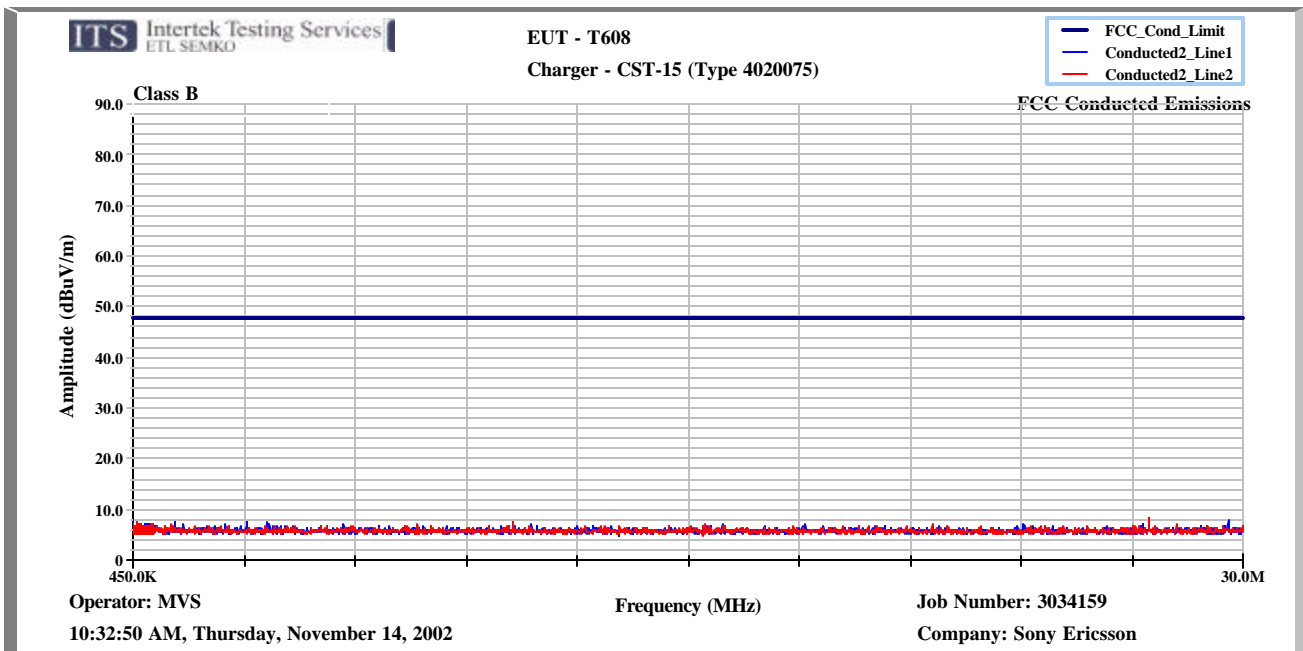

There were no emissions detected within 20 dB of the limit.

Intertek Testing Services

Figure 10-3: FCC §15.107 and §15.207 power line conducted emissions (peak) (CST-12)

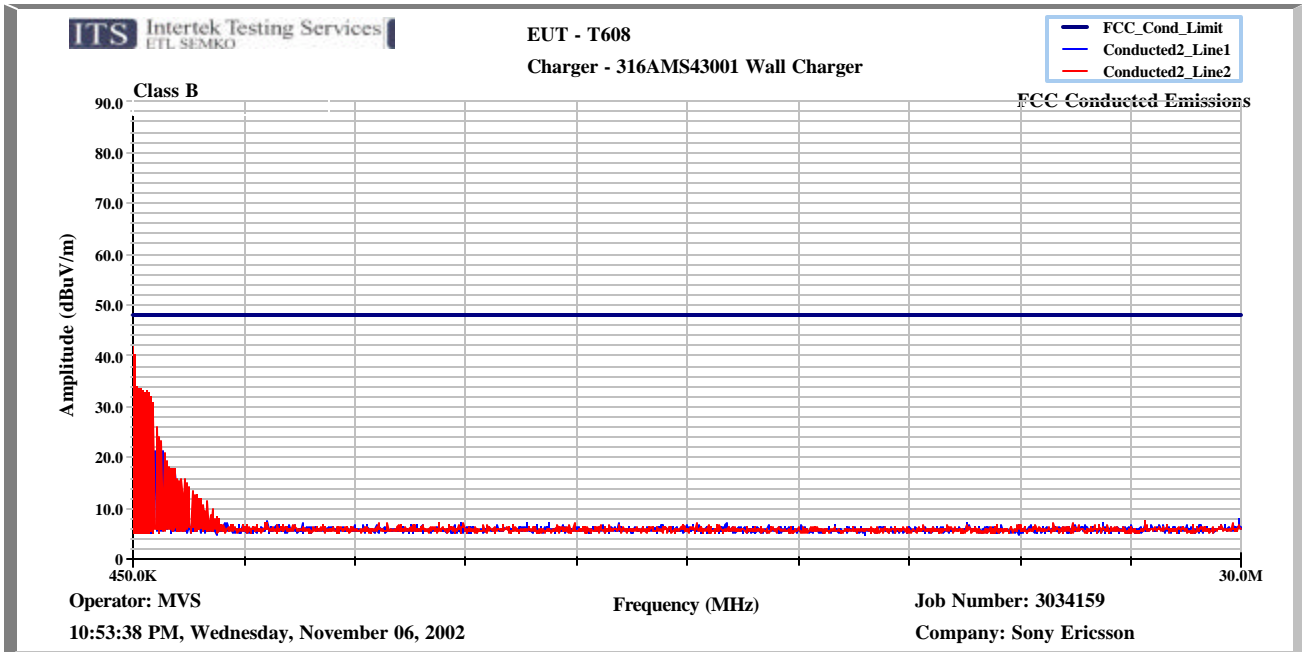

Company: Sony Ericsson
 Model: 316AMS43001 Wall Charger CST-12
 Job No.: 3034159
 Date: 11/06/02
 Standard: FCC15
 Class: B
 Notes:

Tested by: Matthew Van Steen
 Location: Duluth
 Detector: HP8546
 Cable(s): Cable TT4
 Limiter: no

Group: None

Frequency MHz	Reading Side A dB	Reading Side B dB	Attenuator Factor dB	System Loss dB	Quasi-Peak		
					Net dB(uV)	Limit dB(uV)	Margin dB
0.450	32.9	35.8	0.0	1.0	36.8	48.0	-11.2
0.513	23.7	28.1	0.0	1.0	29.1	48.0	-18.9
0.643	15.9	27.2	0.0	1.0	28.2	48.0	-19.8
0.843	16.3	25.7	0.0	1.0	26.7	48.0	-21.3
1.007	14.6	22.4	0.0	1.0	23.4	48.0	-24.6
1.470	10.6	10.9	0.0	1.0	11.9	48.0	-36.1

10.4 Test Configuration Photograph

Figure 10-4 and Figure 10-5 show the testing configurations used.

Figure 10-4: Configuration photograph, AC mains conducted emission, front view

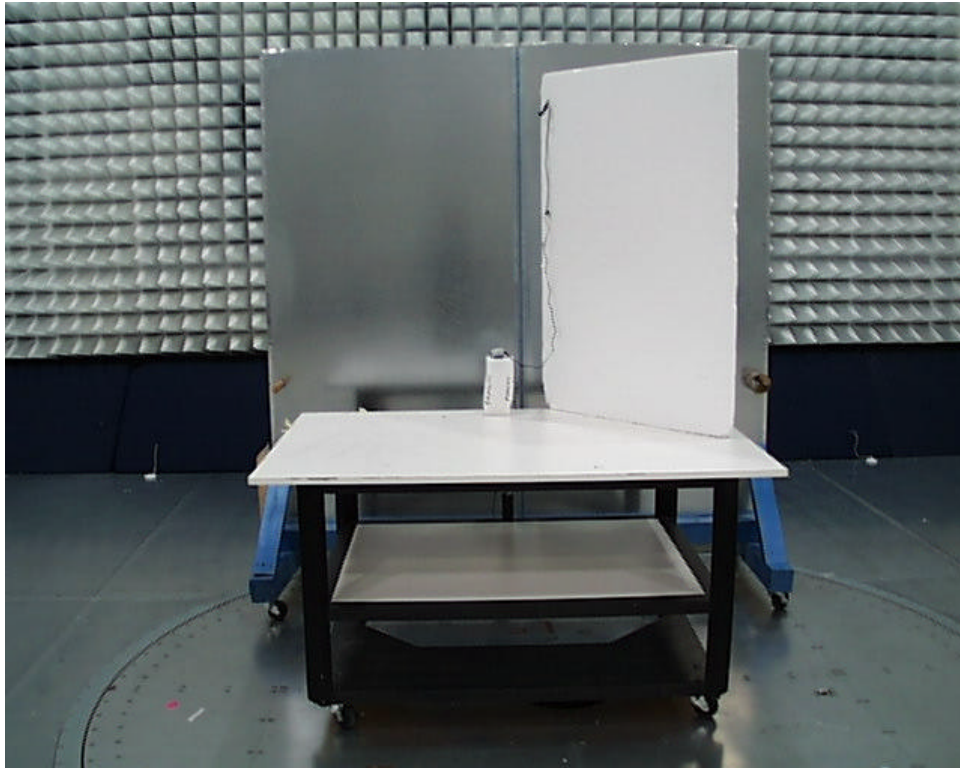

Figure 10-5: Configuration photograph, AC mains conducted emission, rear view



11 FREQUENCY STABILITY VS TEMPERATURE

FCC §2.1055, FCC §22.355, FCC §24.235, IC RSS-133

Frequency tolerance: 2.5ppm

11.1 Test Procedure

The equipment under test was connected to an external DC power supply and the RF output was connected to a frequency counter via feedthrough attenuators. The EUT was placed inside the temperature chamber. The DC leads, RF output cable, and external PTT cable exited the chamber through an opening made for that purpose.

After the temperature stabilized for approximately 30 minutes, the external PTT switch was activated, and the frequency output was recorded from the counter.

11.2 Test Equipment

Description	Manufacturer	Model Number	Serial Number	Calibration due date
DC Power Supply	Tektronix	PS2352G	TW50199	12/5/02
CDMA mobile station test set	HP	8924C	US39224578	11/15/03
PCS Interface	HP	83236B	3711J305170	11/15/03
Temperature Chamber	Thermotron	SE-600-3-3	29411	2/4/2003

11.3 Test Results

The Dual Band Tri-mode CDMA Cellular Phone met the frequency stability requirements of FCC §2.1055, FCC §22.355, FCC §24.235, IC RSS-133. The test results are located in Table 11-1 and Table 11-2.

Intertek Testing Services

Table 11-1: CDMA1900 Channel 600, Frequency stability vs. Temperature

Tx Frequency: 1880 MHz
Tolerance: +/-4700 Hz

Temperature (°C)	Difference (Hz)
60	-39.6
50	+44.9
40	+50.3
30	-25.7
20	-35.2
10	-22.4
0	+32.1
-10	+34.1
-20	+14.7
-30	+19.1

Table 11-2: CDMA800 Channel 384, Frequency stability vs. Temperature

Tx Frequency: 836.52 MHz
Tolerance: +/-2091Hz

Temperature (°C)	Difference (Hz)
60	+12.2
50	+24.0
40	+28.4
30	-14.4
20	+15.3
10	+21.2
0	-18.0
-10	-18.4
-20	-7.4
-30	-10.7

12 FREQUENCY STABILITY VS VOLTAGE

FCC §2.1055, FCC §22.355

Frequency tolerance: 2.5ppm

12.1 Test Procedure

An external variable DC power supply was connected to the battery terminals of the equipment under test. The voltage was set to 115% of the nominal value and was then decreased to the battery end point, which was determined by Sony Ericsson to be 85% of the nominal value. The output frequency was recorded for each battery voltage.

12.2 Test Equipment

Description	Manufacturer	Model Number	Serial Number	Calibration due date
DC Power Supply	Tektronix	PS2352G	TW50199	12/5/02
CDMA mobile station test set	HP	8924C	US39224578	11/15/03
PCS Interface	HP	83236B	3711J305170	11/15/03
Temperature Chamber	Thermotron	SE-600-3-3	29411	2/4/2003

12.3 Test Results

The Dual Band Tri-mode CDMA Cellular Phone met the frequency stability requirements of FCC §2.1055, FCC §22.355. The test results are located in Table 12-1, and Table 12-2.

Intertek Testing Services

Table 12-1: CDMA 1900 Channel 600, Frequency stability vs. input voltage

Tx Frequency: 1880 MHz

Tolerance: +/-4700 Hz

Supply (Battery)	Difference
Volts	(Hz)
3.4	-35.9
3.5	+17.5
3.6	+36.1
3.7	-28.5
3.8	-34.0
3.9	-29.3
4	-15.5
4.1	+44.5
4.2	-26.7

Table 12-2: CDMA 800 Channel 384, Frequency stability vs. input voltage

Tx Frequency: 836.52 MHz

Tolerance: +/-2091 Hz

Supply (Battery)	Difference
Volts	(Hz)
3.4	+33.8
3.5	-26.6
3.6	+28.2
3.7	+59.6
3.8	-18.2
3.9	-15.5
4	-12.3
4.1	+1.9
4.2	+20.2

13 RECEIVER SPURIOUS EMISSIONS

13.1 Test Limits

Table 13-1 Radiated Emission Limit for FCC §15.109, IC RSS-129 §10, and IC RSS-133 §9

Radiated Emission Limits at 3 meters	
Frequency (MHz)	Quasi-Peak limits, dB (µV/m)
30 to 88	40.0
88 to 216	43.5
216 to 960	46.0
960 and up	54.0

13.2 Test Equipment

Description	Make	Model	Serial #	Cal Due Date
EMI Receiver	HP	85462A	3650A00362	3/28/03
RF Filter Selector	HP	85460A	3704A00331	3/28/03
Spectrum Analyzer	HP	8566B	2134A01032 / 2344A05843	12/4/02
PreAmp	HP	8449B	3008A0089	10/30/03
BiLog Antenna	Chase	CBL6112B	2622	8/26/03
Horn Antenna	AH Systems	SAS200/571	246	1/21/03
Cable	N/A	Cable N2	ITS# 211999a2	6/12/03
Cable	N/A	CableTW2	ITS# 211411	6/12/03
Cable	N/A	CableTW3	ITS# 211412	6/12/03

13.3 Test Procedure

Measurements are made over the frequency range of 30 MHz to five times the highest frequency operating within the device. The measuring receiver meets the requirements of Section One of CISPR 16 and the measuring antenna correlates to a balanced dipole. From 30 to 1000 MHz, a quasi-peak detector was used for measurement. Above 1000 MHz, average measurements were performed.

Measurements of the radiated field are made with the antenna located at a distance of 3 meters from the EUT. If the field-strength measurements at 3m cannot be made because of high ambient noise level or for other reasons, measurements may be made at a closer distance, for example 1m. An inverse proportionality factor of 20 dB per decade should be used to normalize the measured data to the specified distance for determining compliance.

The antenna is adjusted between 1m and 4m in height above the ground plane for maximum meter reading at each test frequency.

The antenna-to-EUT azimuth is varied during the measurement to find the maximum field-strength readings.

Intertek Testing Services

The antenna-to-EUT polarization (horizontal and vertical) is varied during the measurements to find the maximum field-strength readings.

The EUT, where intended for tabletop use, is placed on a table whose top is 0.8m above the ground plane. The table is constructed of non-conductive materials. Its dimensions are 1m by 1.5m, but may be extended for larger EUT.

Floor standing EUTs are placed on a horizontal metal ground plane and isolated from the ground plane by 3 to 12 mm of insulating material.

Equipment setup for radiated disturbance tests followed the guidelines of ANSI C63.4: 1992.

13.4 Test Results

The Dual Band Tri-mode CDMA Cellular Phone met the radiated disturbance requirements of FCC §15.109, IC RSS-129, and IC RSS-133. The test results are located in Figure 13-1. There were no other emissions detected within 10 dB of the limit.

Figure 13-1 FCC §15.109, IC RSS-129, and IC RSS-133 Worst Case Receiver Spurious Emissions

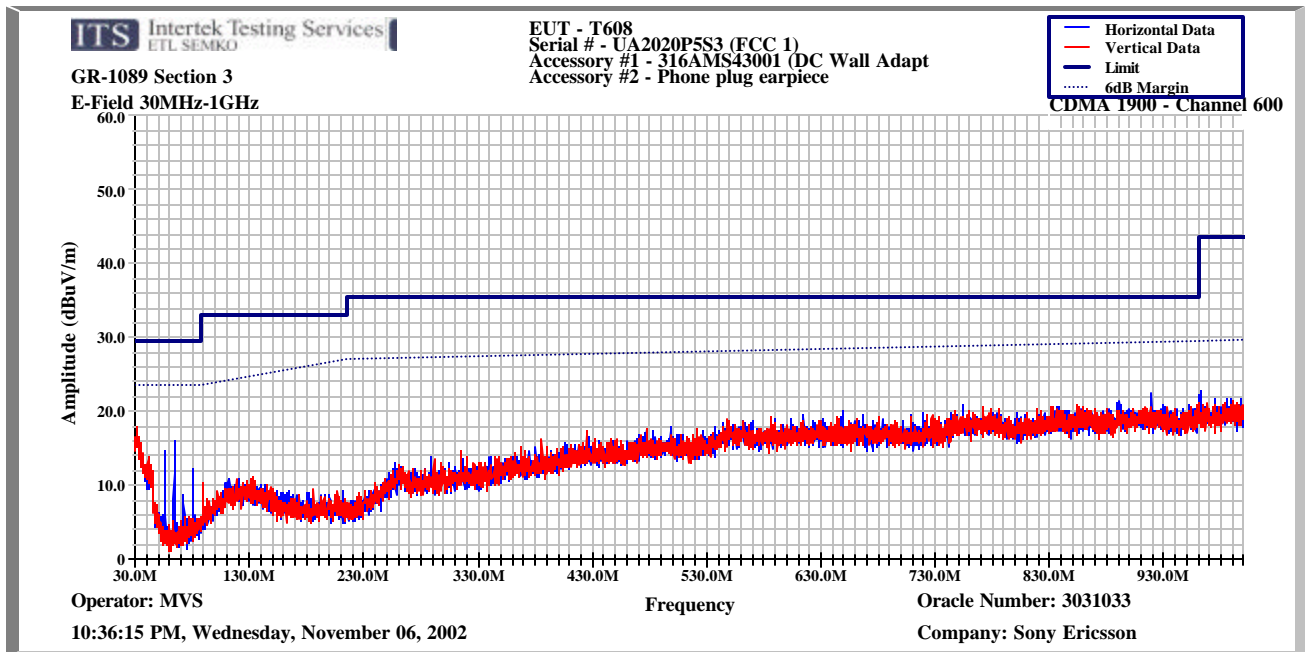

13.5 Test Configuration Photograph

Figure 13-1 and Figure 13-2 show the testing configurations used.

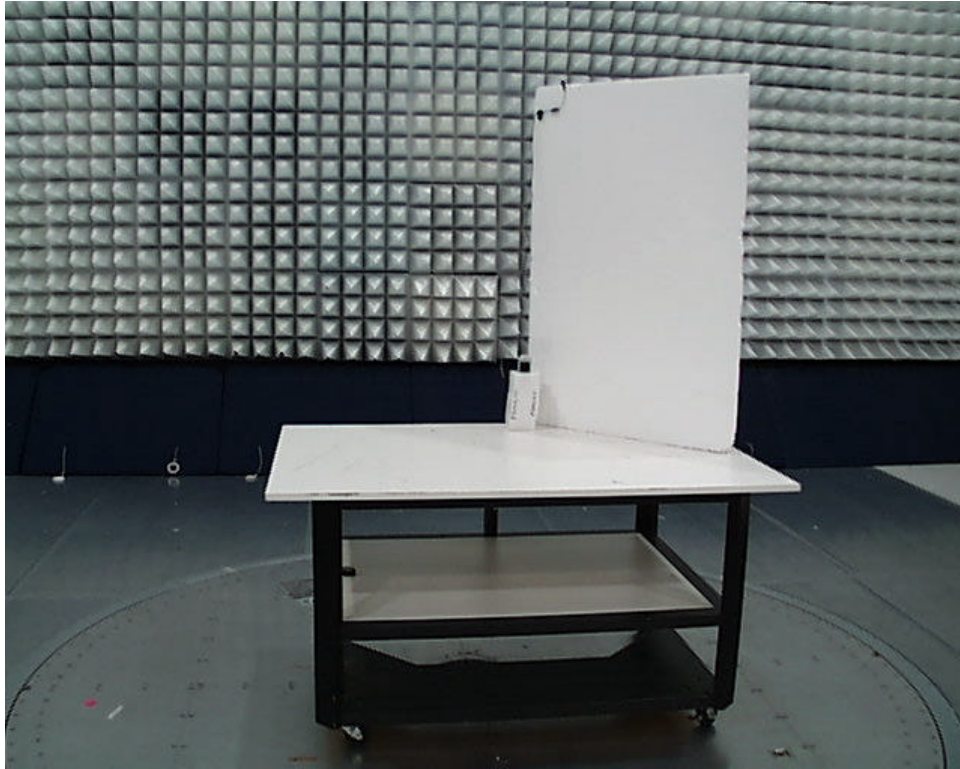

Figure 13-1: Configuration photograph, radiated emission, front view



Figure 13-2: Configuration photograph, radiated emission, rear view