



**TEST REPORT**

**Report Number: 0123646U.doc**  
**Project Number: 3023646**  
**May 16, 2002**

**Evaluation of the**  
**Dual Band Tri-mode CDMA Cellular Phone**  
**Model Number: T206**  
**FCC ID: PXITR-503-A2**  
**IC: 4170A-TR503**  
**to**

**FCC Part 15**  
**FCC Part 22 Subpart H**  
**FCC Part 24 Subpart E**  
**IC RSS-129**  
**IC RSS-133**

**For**

**Sony Ericsson Mobile Communications Inc.**

Test Performed by:  
Intertek Testing Services  
1950 Evergreen Blvd, Suite 100  
Duluth, GA 30096

Test Authorized by:  
Sony Ericsson Mobile Communications Inc.  
7001 Development Drive  
Research Triangle Park, NC 27709

Prepared by: \_\_\_\_\_  
Grace Lin, Sr. Project Engineer

Date: \_\_\_\_\_

Reviewed by: \_\_\_\_\_  
David J. Schramm, EMC Team Leader

Date: \_\_\_\_\_

*All services undertaken are subject to the following general policy: Reports are submitted for exclusive use of the client to whom they are addressed. Their significance is subject to the adequacy and representative character of the samples and to the comprehensiveness of the tests, examinations or surveys made. This report shall not be reproduced except in full, without written consent of Intertek Testing Services NA Inc. This report must not be used to claim product endorsement by A2LA, NIST nor any other agency of the U.S. Government.*

TABLE OF CONTENTS

**EXECUTIVE SUMMARY ..... 4**

**1 JOB DESCRIPTION ..... 5**

1.1 CLIENT INFORMATION ..... 5

1.2 TEST PLAN REFERENCE: ..... 5

1.3 EQUIPMENT UNDER TEST (EUT) ..... 6

    1.3.1 System Support Equipment..... 7

    1.3.2 Cables associated with EUT ..... 7

    1.3.3 System Block Diagram..... 7

    1.3.4 Justification..... 8

    1.3.5 Mode(s) of operation..... 8

1.4 MODIFICATIONS REQUIRED FOR COMPLIANCE ..... 8

1.5 RELATED SUBMITTAL(S) GRANTS ..... 8

**2 TEST FACILITY ..... 9**

**3 RF POWER OUTPUT ..... 10**

3.1 TEST PROCEDURE..... 10

3.2 TEST EQUIPMENT ..... 10

3.3 TEST RESULTS ..... 10

**4 RADIATED POWER ..... 12**

4.1 TEST PROCEDURE..... 12

4.2 TEST EQUIPMENT ..... 12

4.3 TEST RESULTS ..... 13

**5 MODULATION DEVIATION LIMITING ..... 14**

5.1 TEST PROCEDURE..... 14

5.2 TEST EQUIPMENT ..... 14

5.3 TEST RESULTS ..... 14

**6 AUDIO FILTER CHARACTERISTICS..... 17**

6.1 TEST PROCEDURE..... 17

6.2 TEST EQUIPMENT ..... 17

6.3 TEST RESULTS ..... 18

**7 EMISSION LIMITATIONS, OCCUPIED BANDWIDTH ..... 20**

7.1 TEST PROCEDURE..... 20

7.2 TEST EQUIPMENT ..... 20

7.3 TEST RESULTS ..... 21

**8 OUT OF BAND EMISSION AT ANTENNA TERMINALS..... 26**

8.1 TEST PROCEDURE..... 26

8.2 TEST EQUIPMENT ..... 26

8.3 TEST RESULTS ..... 27

**9 FIELD STRENGTH OF SPURIOUS RADIATION ..... 36**

9.1 TEST PROCEDURE..... 36

9.2 TEST EQUIPMENT ..... 36

# Intertek Testing Services

---

9.3	TEST RESULTS .....	36
<b>10</b>	<b>POWER LINE CONDUCTED EMISSIONS .....</b>	<b>38</b>
10.1	TEST PROCEDURE.....	38
10.2	TEST EQUIPMENT .....	38
10.3	TEST RESULTS .....	38
10.4	TEST CONFIGURATION PHOTOGRAPH.....	40
<b>11</b>	<b>FREQUENCY STABILITY VS TEMPERATURE.....</b>	<b>42</b>
11.1	TEST PROCEDURE.....	42
11.2	TEST EQUIPMENT .....	42
11.3	TEST RESULTS .....	42
<b>12</b>	<b>FREQUENCY STABILITY VS VOLTAGE.....</b>	<b>44</b>
12.1	TEST PROCEDURE.....	44
12.2	TEST RESULTS .....	44
<b>13</b>	<b>RECEIVER SPURIOUS EMISSION .....</b>	<b>46</b>
13.1	TEST LIMITS .....	46
13.2	TEST PROCEDURE.....	46
13.3	TEST RESULTS .....	47
13.4	TEST CONFIGURATION PHOTOGRAPH.....	48

## Executive Summary

Testing performed for: Sony Ericsson Mobile Communications Inc.

Equipment Under Test: T206, Dual Band Tri-mode CDMA Cellular Phone

FCC RULE	IC RULE	DESCRIPTION OF TEST	RESULT	PAGE
§2.1046	RSS-129 §7.1, §9.1 RSS-133 §6.2	RF Power Output	Passed	10
§22.913, §24.232	RSS-129 §7.1, §9.1 RSS-133 §6.2	ERP, EIRP	Passed	13
§2.1047 §22.915(b)(c)	RSS-129 §5.9, §6.1	Modulation Deviation Limiting	Passed	14
§22.915(d)(1)	RSS-129 §6.2	Audio Filter Characteristics	Passed	17
§2.1049 §22.917(b)(d)	RSS-129 §6.3, RSS-129 §8.1	Emission Limitation, Occupied Bandwidth	Passed	20
§2.1051 §22.917(e) §22.917(f) §24.238(a)	RSS-129 §6.3, §7.2.2, §8.1.1, §10 RSS-133 §6.3	Out of Band Emissions at Antenna Terminals Mobile Emissions In Base Frequency Range	Passed	26
§2.1053	RSS-129 §8.1	Field Strength of Spurious Radiation	Passed	36
§15.107, §15.207	IC ES-003	Power Line Conducted Emissions	Passed	38
§2.1055, §22.355, §24.235	RSS-133 §7	Frequency Stability vs. Temperature	Passed	42
§2.1055, §22.355, §24.235	--	Frequency Stability vs. Voltage	Passed	44
§2.1091, §2.1093	RSS-129 §11, RSS-133 §8	Specific Absorption Rate	N/S	See Note <sup>1</sup>
§15.109	IC ES-003 RSS-129 §10, RSS-133 §9	Receiver Spurious Emission	Passed	

N/S: Not under scope of this evaluation

---

<sup>1</sup> Specific Absorption Rate testing was not under the scope of this evaluation.

## 1 JOB DESCRIPTION

### 1.1 Client information

The Dual Band Tri-mode CDMA Cellular Phone has been tested at the request of

**Company:** Sony Ericsson Mobile Communications Inc.  
7001 Development Drive  
Research Triangle Park, NC 27709

**Name of contact:** Pierre Chery  
**Telephone:** 919-472-1697  
**Fax:** 919-472-6382

### 1.2 Test plan reference:

Tests were performed to the following standards:

- FCC Part 15
- FCC Part 22 Subpart H rules for an intentional radiator
- FCC Part 24 Subpart E rules for an intentional radiator
- IC RSS-129
- IC RSS-133

The test procedures described in this test report and ANSI C63.4: 1992 were employed.

## Intertek Testing Services

---

### 1.3 Equipment Under Test (EUT)

Product	Dual Band Tri-mode CDMA Cellular Phone
EUT Model Number	T206
EUT Serial Number	UA2020NPF4
Whether quantity (>1) production is planned	Quantity production is planned.
Cellular Phone standards	AMPS, CDMA and CDMA (PCS)
Type(s) of Emission	40K0F8W, 40K0F1D, 1M30G9W
RF Output Power	824-849 MHz: 26.07 dBm - AMPS 824-849 MHz: 23.40 dBm - CDMA 1850-1910 MHz: 23.75 dBm - CDMA
Frequency Range	824 – 849 AMPS and CDMA 1850 – 1910 CDMA (PCS)
Antenna & Gain	Integrated, non-retractable
Detachable Antenna ?	No
External input	<input checked="" type="checkbox"/> Audio <input type="checkbox"/> Digital Data

EUT receive date: May 6, 2002  
EUT receive condition: The EUT was received in good condition with no apparent damage.  
Test start date: May 6, 2002  
Test completion date: May 14, 2002

The test results in this report pertain only to the item tested.

# Intertek Testing Services

## 1.3.1 System Support Equipment

Table 1.3-1 contains the details of the support equipment associated with the Equipment Under Test during the FCC Part 15 and ICES-003 testing.

Table 1.3-1: System Support Equipment

Description	Manufacturer	Model Number	Serial Number	FCC ID number
Hands-free accessory	Sony Ericsson	RLF 501 25/03	Not labeled	Not labeled
Home charging base	Sony Ericsson	S16AMS43001	0213	Not labeled

## 1.3.2 Cables associated with EUT

Table 1.3-2 contains the details of the cables associated with the EUT.

Table 1.3-2: Interconnecting cables between modules of EUT

Cables					
Description	Length	Shielding	Ferrites	Connection	
				From	To
Adapter cable	2m	None	None	EUT	Charging adapter
Hands free	1.2m	None	None	EUT	Ear piece

## 1.3.3 System Block Diagram

The diagram shown below details the interconnection of the EUT and its accessories during FCC Part 15 testing. For specific layout, refer to the test configuration photograph in the relevant section of this report.

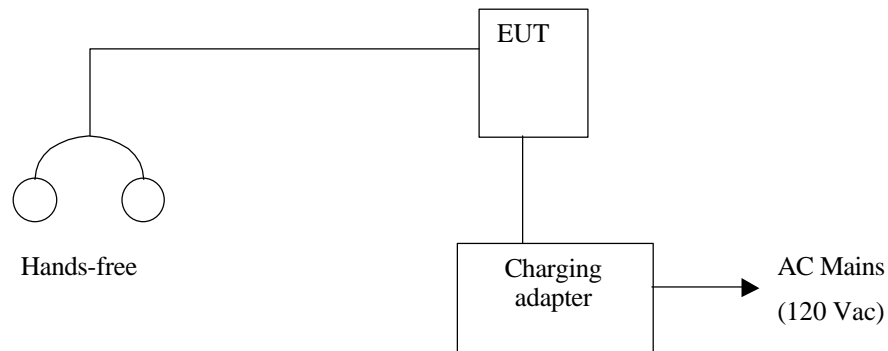

## **1.3.4 Justification**

The EUT was operated in the stand-alone configuration.

## **1.3.5 Mode(s) of operation**

The EUT was powered from 3.8 Vdc.

The EUT was set to the AMPS, CDMA 800, or CDMA 1900 (PCS) mode during testing.

## **1.4 Modifications required for compliance**

No modifications were implemented by Intertek Testing Services.

## **1.5 Related Submittal(s) Grants**

None



## 2 TEST FACILITY

The ITS-Duluth site is located at 1950 Evergreen Blvd., Suite 100, Duluth, Georgia. The radiated emission test site is a 10-meter semi-anechoic chamber. The chamber meets the characteristics of CISPR 16-1: 1993 and ANSI C63.4: 1992. For measurements, a remotely controlled flush-mount metal-top turntable is used to rotate the EUT a full 360 degrees. A remote controlled non-conductive antenna mast is used to scan the antenna height from one to four meters.

This site is on file with the FCC.

The Industry Canada file number for this site is IC 2077.

### 3 RF POWER OUTPUT

FCC §2.1046, IC RSS-129 §7.1 and §9.1, IC RSS-133 §6.2

#### 3.1 Test Procedure

The transmitter output was connected to a calibrated coaxial attenuator, the other end of which was connected to a power meter. Transmitter output was read off the power meter in dBm. The power output at the transmitter antenna port was determined by adding the value of the attenuator to the power meter reading.

Tests were performed at three frequencies (low, middle, and high channels) and on the highest power levels, which can be setup on the transmitters.

#### 3.2 Test Equipment

Description	Manufacturer	Model Number	Serial Number	Calibration due date
Power meter	HP	436A	1930A05553	3/29/03
Power sensor	HP	8481A	173690	3/29/03
Attenuator	Weinschel	2 (10 dB)	BK2313	5/6/03

#### 3.3 Test Results

The Dual Band Tri-mode CDMA Cellular Phone met the RF power output requirements of FCC Part 22 Subpart H, FCC Part 24 Subpart E, IC RSS-129 §7.1 and §9.1, and IC RSS-133 §6.2. The test results are located in Table 3.3-1.

*Table 3.3-1 RF Power Output*

EUT Mode	Frequency MHz	Channel	Measured Power dBm
AMPS	824.04	991	26.07
	836.49	383	26.00
	848.97	799	25.83
CDMA800	824.70	1013	23.40
	836.52	384	23.36
	848.31	777	23.35
CDMA PCS	1851.25	25	23.75
	1880.00	600	23.25
	1908.75	1175	23.35

## Intertek Testing Services

---

EUT Mode	Frequency MHz	Channel	Measured Power dBm		
			+60°C	+20°C	-30°C
AMPS	824.04	991	25.95	26.07	25.89
	836.49	383	26.02	26.00	25.93
	848.97	799	25.54	25.83	25.65
CDMA800	824.70	1013	22.70	23.40	22.65
	836.52	384	22.91	23.36	22.75
	848.31	777	22.81	23.35	22.29
CDMA1900	1850.20	25	23.70	23.75	23.69
	1880.00	600	23.22	23.25	23.18
	1909.80	1175	23.29	23.35	23.22

**4 RADIATED POWER**

FCC §22.913 and IC RSS-129 §7.1 and §9.1: The Effective Radiated Power (ERP) of mobile transmitters and auxiliary test transmitters must not exceed 7 Watts.

FCC §24.232 and IC RSS-133 §6.2: The equivalent Isotropic Radiated Power (EIRP) must not exceed 2 Watts.

**4.1 Test Procedure**

The EUT was positioned on a non-conductive tripod, 1.5m above the ground plane inside a 10 meter semi-anechoic chamber. The radiated emission at the fundamental frequency was measured at 3m with a test antenna and EMI receiver.

During the measurement of the EUT, the receiver resolution bandwidth was set to 3 MHz and the average bandwidth was set to 10 kHz. These settings matched the power readings of a power meter with a thermocouple power sensor. The highest emission was recorded with the rotation of the turntable and the raising and lowering of the test antenna. The receiver reading was recorded and the field strength (E in dBμV/m) was calculated.

ERP in frequency band 824-849 MHz, and EIRP in frequency band 1851.25-1910 MHz were measured using a substitution method. The EUT was replaced by half-wave dipole (824-849 MHz) or horn antenna (1851.25-1910 MHz) connected to a signal generator, which was set to approximately 23 dBm. The spectrum analyzer reading was recorded and ERP/EIRP was calculated as follows:

$$ERP = E_1 - E_2 + V_g$$

$$EIRP = E_1 - E_2 + V_g + G$$

where,

E<sub>1</sub> is the receiver reading in dBμV/m when measuring the field strength of the EUT

E<sub>2</sub> is the receiver reading in dBμV/m when measured field strength from the generator

V<sub>g</sub> is the generator output in dBm

G is the gain of the transmitting antenna in dBi.

**4.2 Test Equipment**

Description	Manufacturer	Model Number	Serial Number	Calibration due date
Power Meter	HP	436A	1930A05553	3/29/03
Power Sensor	HP	8481A	173690	3/29/03
Signal Generator	HP	83620B	3722A00537	2/11/03
Dipole Antenna	CDI	A100	R4	8/1/02
Horn Antenna	A.H. Systems	SAS-200/571	246	1/13/03
Receive Antenna	Schaffner-Chase	CBL6112B	2622	8/14/02
EMI Receiver	HP	8546A	3410A00173/ 3448A00203	3/28/03
Attenuator	Weinschel	2 (10dB)	BK2313	5/6/03

### 4.3 Test Results

The Dual Band Tri-mode CDMA Cellular Phone met the radiated power requirements of FCC §22.913, FCC §24.232, IC RSS-129 §7.1 and §9.1, and IC RSS-133 §6.2. The test results are located in Table 4.3-1.

*Table 4.3-1 RF Power Output*

EUT Mode	Measurement Method	Frequency MHz	Channel	Measured Power dBm
AMPS	ERP	824.04	991	23.84
	ERP	836.49	383	24.22
	ERP	848.97	799	24.00
CDMA800	ERP	824.70	1013	21.01
	ERP	836.52	384	21.59
	ERP	848.31	777	20.96
CDMA PCS	EIRP	1851.25	25	21.42
	EIRP	1880.00	600	21.42
	EIRP	1908.75	1175	22.16

## 5 MODULATION DEVIATION LIMITING

FCC §2.1047, FCC §22.915(b)(c), RSS-129 §5.9, and §6.1

### Digital Modulation Techniques

Cdma2000, 1XRTT Mode uses Binary Phase Shift Keying (BPSK) modulation with a pilot.  
CdmaOne (IS-95) Mode uses Offset Quadrature Phase Shift Keying (OQPSK).

### 5.1 Test Procedure

The RF output of the transceiver was connected to the input of a CDMA mobile station test set with PCS interface through sufficient attenuation so as not to overload the meter or distort the readings. The CDMA mobile station test set was configured as an audio signal generator and was coupled into the external microphone jack of the transceiver, or alternatively, the microphone element was removed and the generator output was connected to the microphone wires by clip leads.

At three different modulating frequencies, the output level of the audio generator was varied from -30 to +30 dB in reference to the level required to generate 8kHz deviation at 1kHz. The CDMA mobile station test set was setup to generate the audio input and record the modulation output of the EUT.

### 5.2 Test Equipment

Description	Manufacturer	Model Number	Serial Number	Calibration due date
CDMA mobile station test set	HP	8924C	US37111069	11/6/02
PCS Interface	HP	83236B	3711J02934	11/6/02
Attenuator	Weinschel	2 (10dB)	BK2313	5/6/03

### 5.3 Test Results

The deviation is not to exceed 12 kHz. The Dual Band Tri-mode CDMA Cellular Phone met the modulation deviation limiting requirements of FCC §22.915(b)(c), and IC RSS-129 §5.9, and §6.1. The test results are located in Figure 5.3-1.

Figure 5.3-1: Modulation Deviation Limiting – Voice

Manufacturer: Sony Ericsson  
EUT: T206 (UA2020NPF4)  
FCCID: PXITR-503-A2  
IC: 4170A-TR503

**Modulation Limiting: Voice**

Tested by: David Schramm  
Date: 5/8/2002  
Project: 3023646

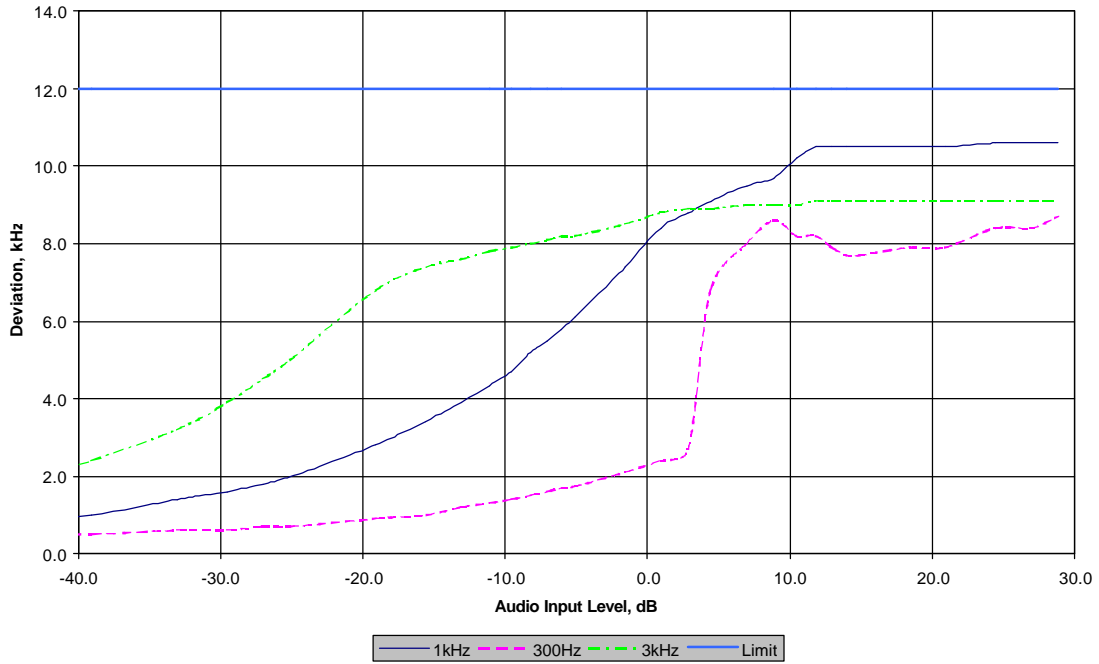
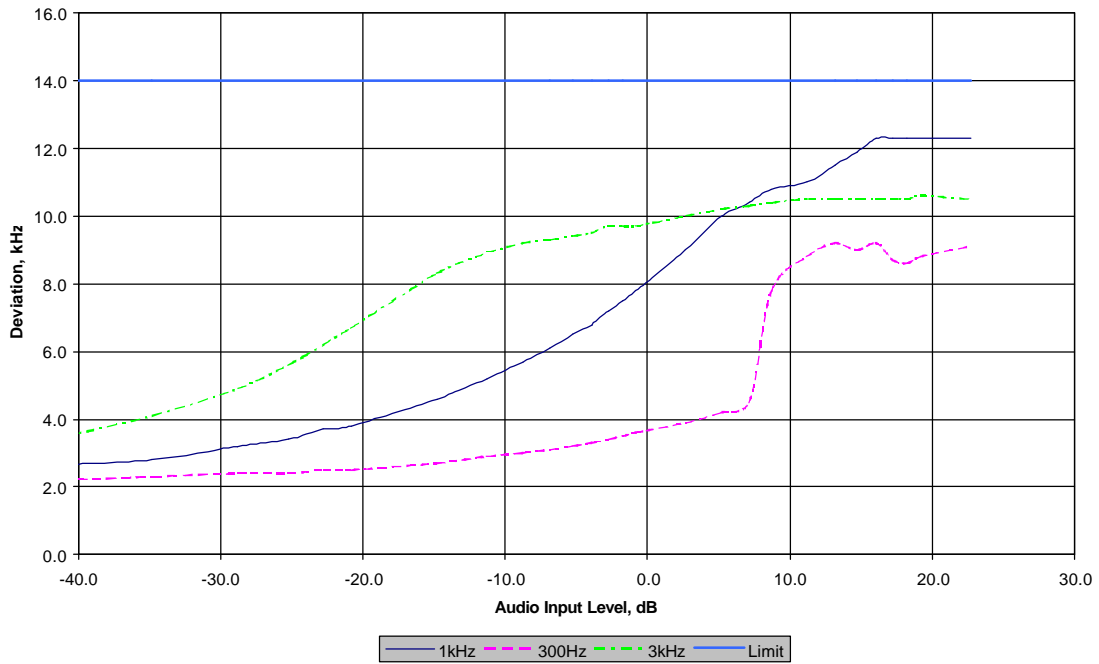

Figure 5.3-2: Modulation Deviation Limiting – Voice and SAT

Manufacturer: Sony Ericsson  
EUT: T206 (UA2020NPF4)  
FCCID: PXITR-503-A2  
IC: 4170A-TR503

**Modulation Limiting: Voice + SAT**

Tested by: David Schramm  
Date: 5/8/2002  
Project: 3023646





**6 AUDIO FILTER CHARACTERISTICS**

CFR 47 §22.915(D), IC RSS-129 §6.2

**6.1 Test Procedure**

The RF output of the transceiver was connected to the input of a CDMA mobile station test set through sufficient attenuation so as not to overload the meter or distort the readings. An audio signal generator of the CDMA mobile station test set was coupled into the external microphone jack of the transceiver, or alternatively, the microphone element was removed and the generator output was connected to the microphone wires by clip leads.

The test was performed according to the block diagram shown below.

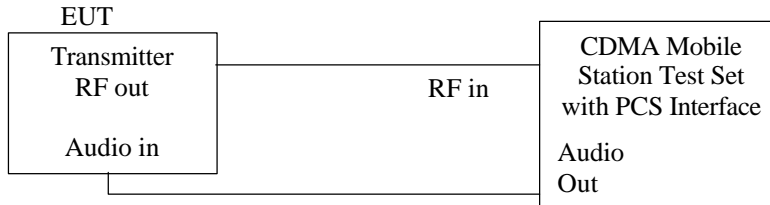

Audio Filter Characteristics

Operate the transmitter with the compander disabled, and monitor the output with a deviation meter without standard 750 microsecond de-emphasis, and without C-message weighted filter. Apply a sine wave audio input to the transmitter external audio input port, vary the modulating frequency from 300 to 3000 Hz, and observe the input levels necessary to maintain a constant  $\pm 2.9$  kHz system deviation.

From 300 to 3000 Hz the audio frequency response shall not vary more than +1 to -3 dB from a true 6 dB/octave pre-emphasis characteristic referred to the 1000 Hz level (with the exception of a permissible 6 dB/octave roll-off from 2500 to 3000 Hz).

Post Limiter Attenuation

Adjust the audio input frequency to 1000 Hz, and adjust the input level to 20 dB greater than that required to produce  $\pm 8$  kHz deviation. Note the output level on the frequency deviation meter. Using this output as reference (0 dB), vary the modulating frequency from 3000 Hz to 30,000 Hz, and observe the change in output while maintaining a constant audio input level.

For mobile stations, these signals must be attenuated, relative to the level at 1 kHz, as follows:

- In the frequency ranges of 3.0 to 5.9 kHz and 6.1 to 15.0 kHz, signals must be attenuated by at least  $40 \log (f/3)$  dB, where f is the frequency of the signal in kHz.
- In the frequency range of 5.9 to 6.1 kHz, signals must be attenuated at least 35 dB.
- In the frequency range above 15 kHz, signals must be attenuated at least 28 dB.

**6.2 Test Equipment**

Description	Manufacturer	Model Number	Serial Number	Calibration due date
CDMA mobile station test set	HP	8924C	US37111069	11/6/02
PCS Interface	HP	83236B	3711J02934	11/6/02
Attenuator	Weinschel	2 (10dB)	BK2313	5/6/03

6.3 Test Results

The Dual Band Tri-mode CDMA Cellular Phone met the audio response characteristic requirements of FCC §22.915(d) and IC RSS-129 §6.2. The test results are located in Figure 6.3-1.

Figure 6.3-1: Audio Filter Characteristics

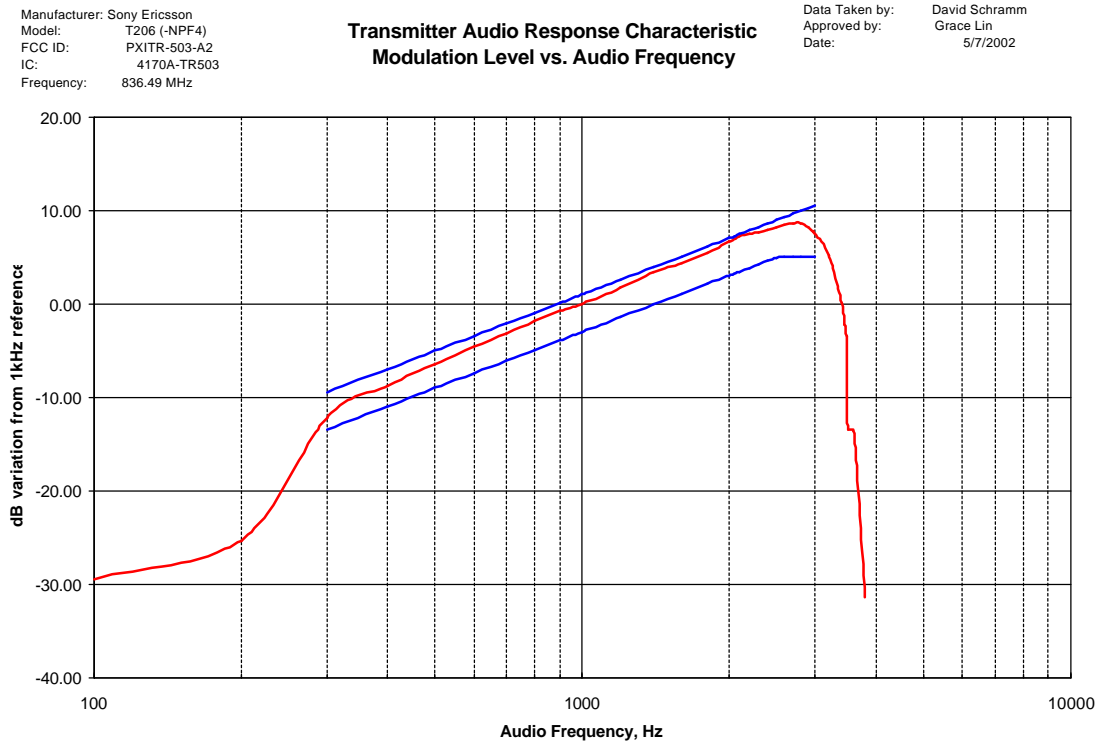
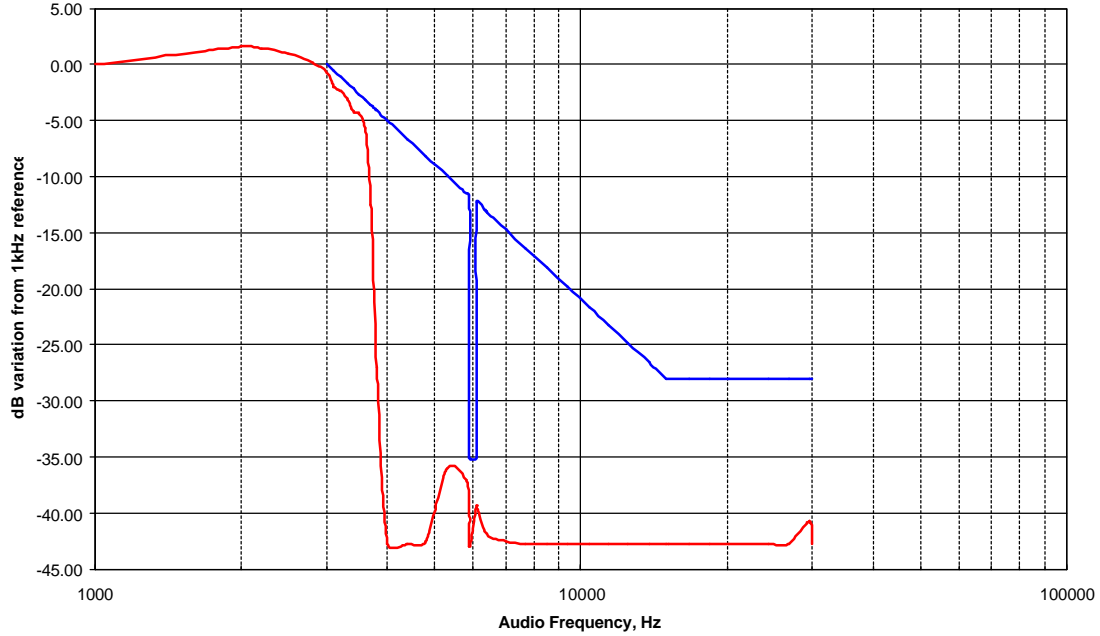

Figure 6.3-2: Post Limiter Filter Attenuation

Manufacturer: Sony Ericsson  
Model: T206 (-NPF4)  
FCC ID: PXITR-503-A2  
IC: 4170A-TR503  
Frequency: 836.49 MHz

**Transmitter Audio Response Characteristic**  
**Post Limiter Filter Attenuation vs. Audio Frequency**

Data Taken by: David Schramm  
Approved by: Grace Lin  
Date: 5/7/2002



## 7 EMISSION LIMITATIONS, OCCUPIED BANDWIDTH

CFR 47 §2.1049, §22.917(b)(d), IC RSS-129 §6.3 and §8.1

For F3E/F3D emission mask uses with audio filter, the mean power of emissions must be attenuated below the mean power of the unmodulated carrier wave (P) as follows:

- On any frequency removed from the carrier frequency by more than 20 kHz but not more than 45 kHz: at least 26 dB;
- On any frequency removed from the carrier frequency by more than 45 kHz, up to the first multiple of the carrier frequency: at least 60 dB or  $43 + 10 \log P$  dB, whichever is the lesser attenuation.

For F1D emission mask, the mean power of emissions must be attenuated below the mean power of the unmodulated carrier (P) as follows:

- On any frequency removed from the carrier frequency by more than 20 kHz but no more than 45 kHz: at least 26 dB;
- On any frequency removed from the carrier frequency by more than 45 kHz but not more than 90 kHz: at least 45 dB;
- On any frequency removed from the carrier frequency by more than 90 kHz, up to the first multiple of the carrier frequency: at least 60 dB or  $43 + 10 \log P$  dB, whichever is the lesser attenuation.

### 7.1 Test Procedure

The RF output of the transceiver was connected to the input of the spectrum analyzer through sufficient attenuation. The audio generator was connected to the audio input of the transceiver.

The spectrum with no modulation was recorded. The audio input signal was adjusted to obtain the frequencies deviation equal 6 kHz at the audio frequency of maximum response which was determined measuring deviation versus frequency from 300 Hz to 3.5 kHz and was found 2.8 kHz. The audio input level was increased by 16 dB. The audio frequency was set to the frequency 2.5 kHz.

The resolution bandwidth of the spectrum analyzer was set at 300 Hz and the spectrum was recorded in the frequency band  $\pm 100$  kHz from the carrier frequency. The same plots were generated for wideband emissions, SAT, ST, DTMF9, Voice, some of the combinations of these modulating signals and in CDMA mode.

### 7.2 Test Equipment

Description	Manufacturer	Model Number	Serial Number	Calibration due date
Spectrum Analyzer	HP	8566B	2134A01032/ 2344A05843	12/3/02
Attenuator	Weinschel	2 (10dB)	BK2313	5/6/03

# Intertek Testing Services

## 7.3 Test Results

The Dual Band Tri-mode CDMA Cellular Phone met the occupied bandwidth requirements of FCC §22.917(b)(d) and IC RSS-129 §6.3 and §8.1.

Table 7.3-1: Summary of test result locations

Location	Mode	Channel	Description
Figure 7.3-1	AMPS	383	Occupied Bandwidth – SAT
Figure 7.3-2	AMPS	383	Occupied Bandwidth – Signaling Tone
Figure 7.3-3	AMPS	383	Occupied bandwidth – SAT and ST
Figure 7.3-4	AMPS	383	Occupied bandwidth – DTMF
Figure 7.3-5	AMPS	383	Occupied Bandwidth – Voice
Figure 7.3-6	AMPS	383	Occupied bandwidth – Voice and SAT
Figure 7.3-7	AMPS	383	Occupied Bandwidth – 10kb Wideband Data

Table 7.3-2: Occupied bandwidth measurements for CDMA modes

Mode	Channel	Resolution Bandwidth	Video Bandwidth	Sweep time	Measured Bandwidth
CDMA800	384	30 kHz	300 kHz	500 ms	1.298 MHz
CDMA 1XRTT	384	30 kHz	300 kHz	500 ms	1.283 MHz
CDMA800	1013	30 kHz	300 kHz	500 ms	1.298 MHz
CDMA 1XRTT	1013	30 kHz	300 kHz	500 ms	1.290 MHz
CDMA800	777	30 kHz	300 kHz	500 ms	1.305 MHz
CDMA 1XRTT	777	30 kHz	300 kHz	500 ms	1.290 MHz
CDMA1900	25	30 kHz	300 kHz	500 ms	1.288 MHz
CDMA1900	600	30 kHz	300 kHz	500 ms	1.300 MHz
CDMA1900	1175	30 kHz	300 kHz	500 ms	1.300 MHz

Figure 7.3-1: Occupied Bandwidth – SAT

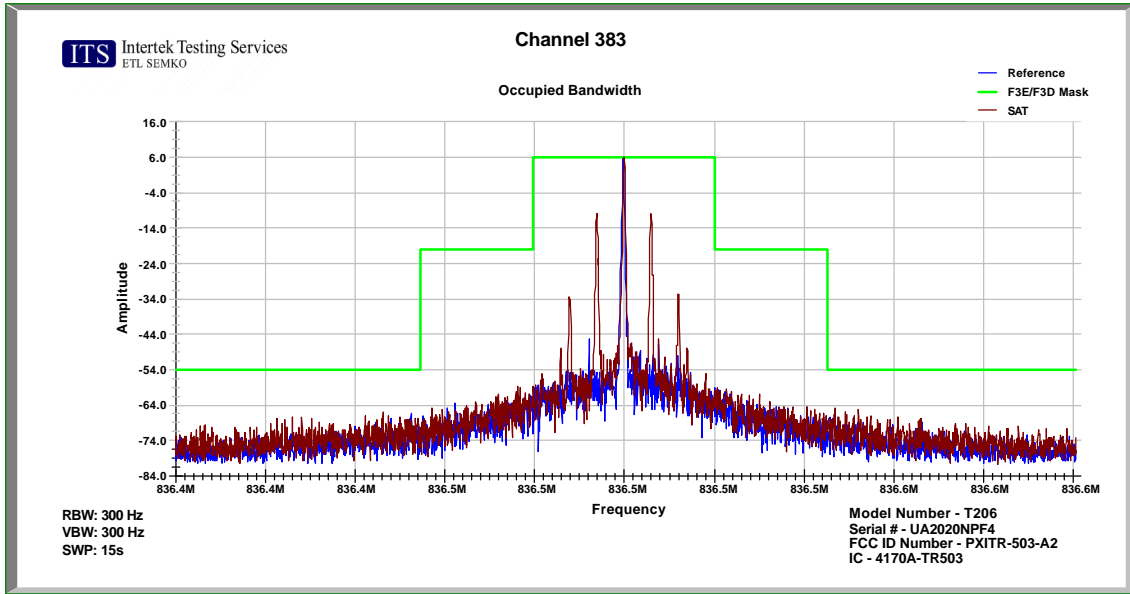

Figure 7.3-2: Occupied Bandwidth – Signaling Tone

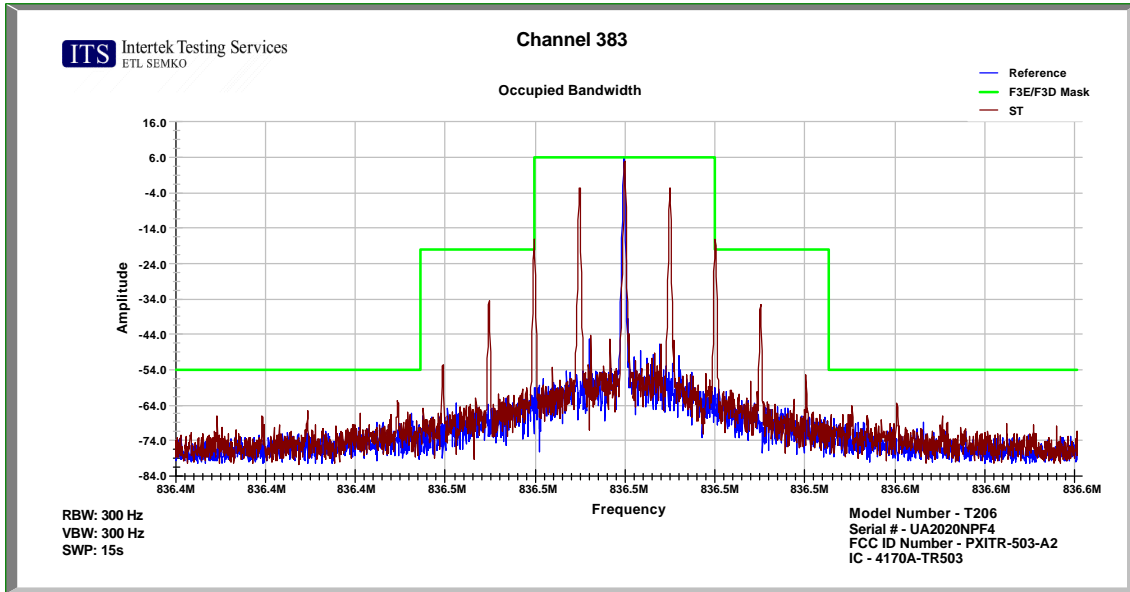

Figure 7.3-3: Occupied bandwidth – SAT and ST

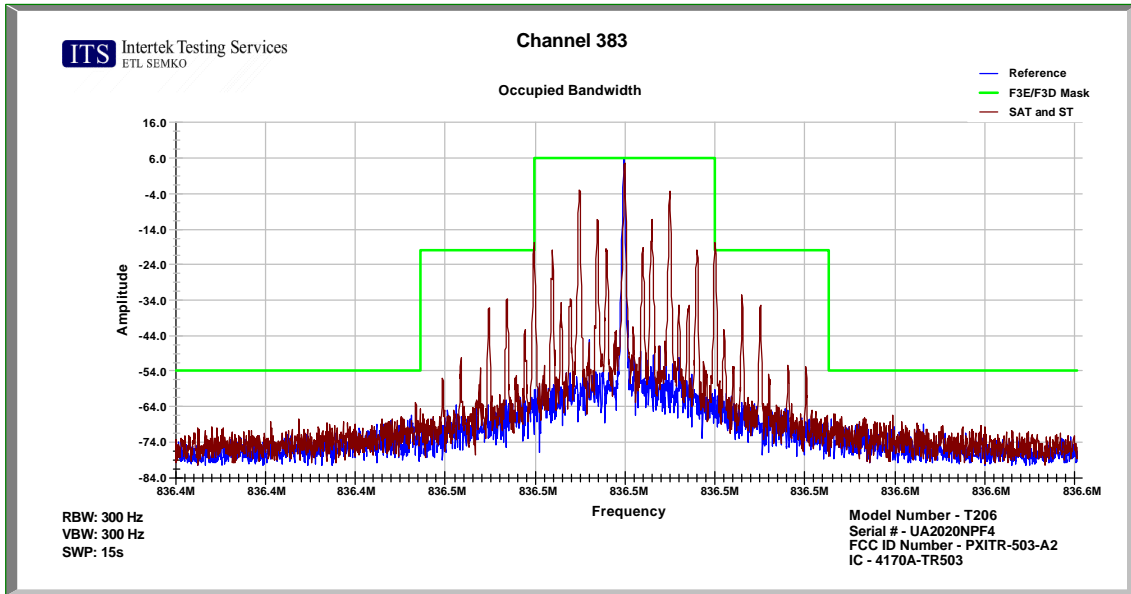
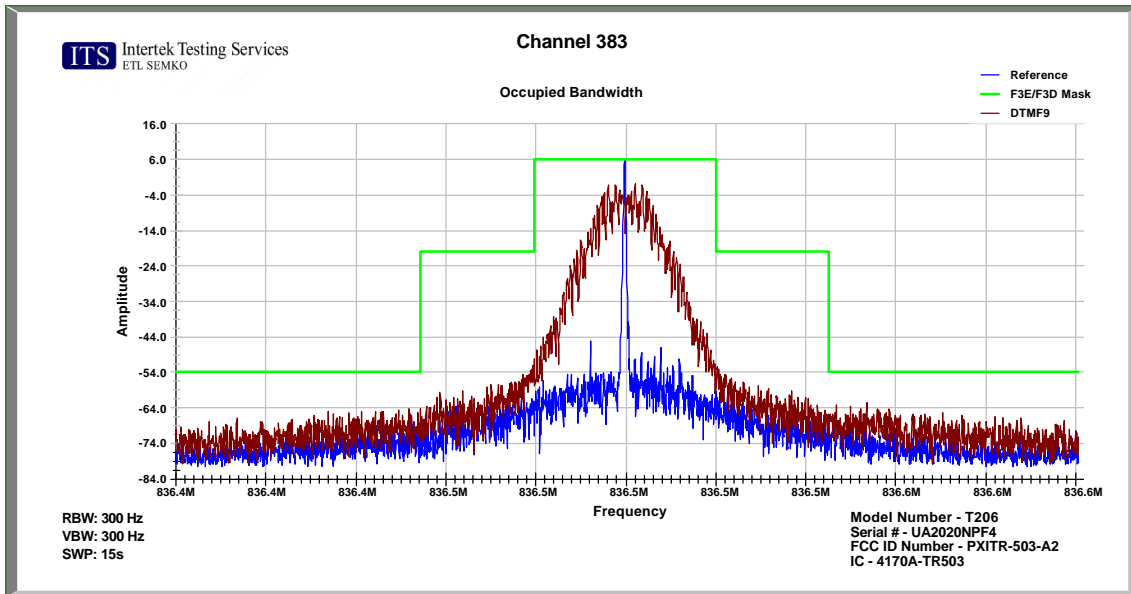

Figure 7.3-4: Occupied bandwidth – DTMF9



# Intertek Testing Services

Figure 7.3-5: Occupied Bandwidth – Voice

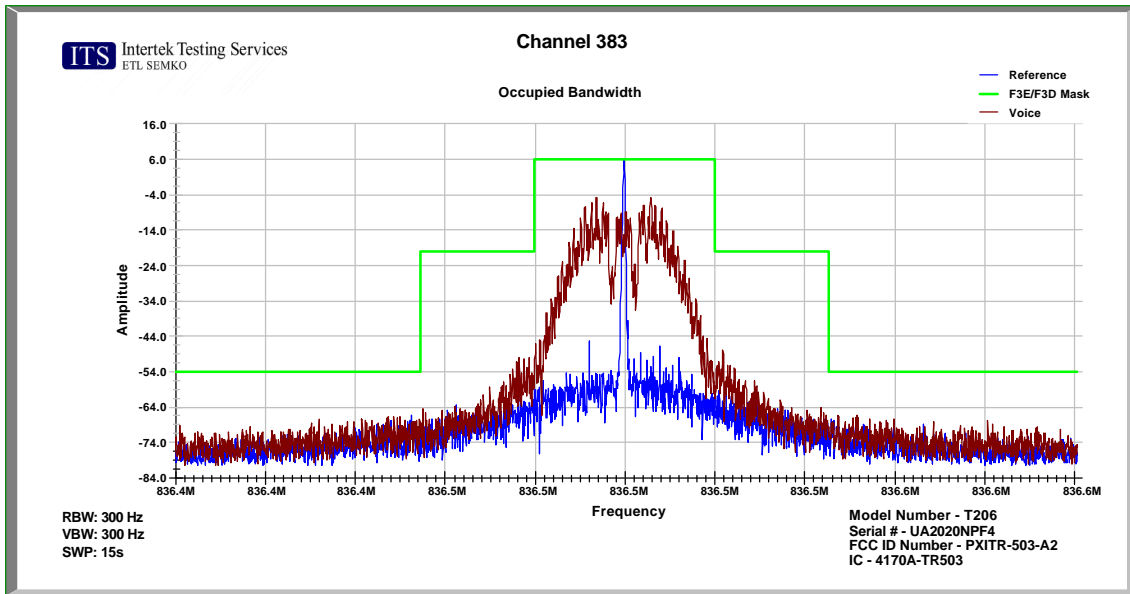

Figure 7.3-6: Occupied bandwidth – Voice and SAT

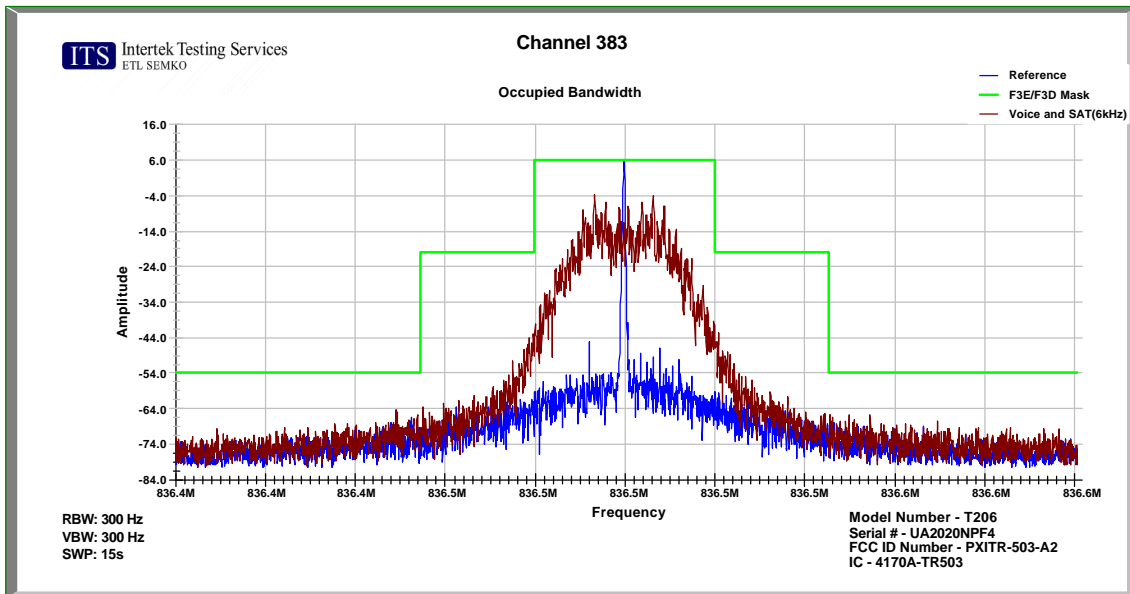
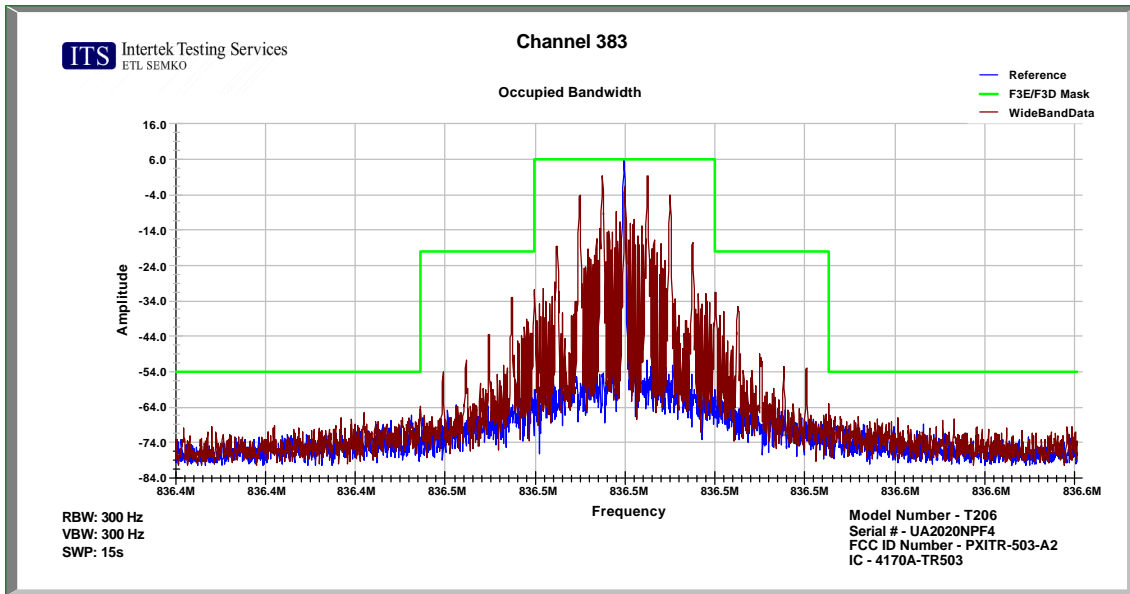



Figure 7.3-7: Occupied Bandwidth – 10kb Wideband Data



**8 OUT OF BAND EMISSION AT ANTENNA TERMINALS**

FCC §2.1047, FCC §22.917(f), FCC §24.238(a), IC RSS-129 6.3, §7.2.2, §8.1.1, and §10, and IC RSS-133 §6.3

Out of Band Emissions: The mean power of emissions must be attenuated below the mean power of the unmodulated carrier (P) on any frequency twice or more than twice the fundamental frequency by at least  $43 + 10 \log P$  dB.

Mobile Emissions in Base Frequency Range: The mean power of any emissions appearing in the base station frequency range from cellular mobile transmitters operated must be attenuated to a level not to exceed -80 dBm at the transmit antenna connector.

**8.1 Test Procedure**

The RF output of the transceiver was connected to a spectrum analyzer through appropriate attenuation. The resolution bandwidth of the spectrum analyzer was set at 30 kHz. The audio modulating signal was adjusted like it is described in Section 6.1 of this report. Sufficient scans were taken to show the out of band Emissions if any up to 10th harmonic.

**8.2 Test Equipment**

Description	Manufacturer	Model Number	Serial Number	Calibration due date
Spectrum Analyzer	HP	8566B	2134A01032/ 2344A05843	12/3/02
Highpass Filter	FILTEK	HP12/1000-5AB	ITS213156	5/6/03
Highpass Filter	FILTEK	HP12/2000-5AB	ITS213156	5/6/03
Notch Filter, tunable	Wainwright Instruments GmbH	WRCO880/960-8 EEK	5	5/14/03
Attenuator	Weinschel	2 (10dB)	BK2313	5/6/03

**8.3 Test Results**

The Dual Band Tri-mode CDMA Cellular Phone met the out of band emission at antenna terminal requirements of FCC §22.917(f), FCC §24.238(a), IC RSS-129 6.3, §7.2.2, §8.1.1, and §10, and IC RSS-133 §6.3.

*Table 8.3-1: Summary of test result locations*

Location	Mode (Band)	Channel	Description
Figure 8.3-1	AMPS	383	Conducted spurious emissions, 30MHz to 10 GHz
Figure 8.3-2	AMPS	799	Conducted spurious emissions, 30MHz to 10 GHz
Figure 8.3-3	AMPS	991	Conducted spurious emissions, 30MHz to 10 GHz
Figure 8.3-4	CDMA800	384	Conducted spurious emissions, 30MHz to 10 GHz
Figure 8.3-5	CDMA800	777	Conducted spurious emissions, 30MHz to 10 GHz
Figure 8.3-6	CDMA800	1013	Conducted spurious emissions, 30MHz to 10 GHz
Figure 8.3-7	CDMA1900	25	Conducted spurious emissions, 30MHz to 20 GHz
Figure 8.3-8	CDMA1900	600	Conducted spurious emissions, 30MHz to 20 GHz
Figure 8.3-9	CDMA1900	1175	Conducted spurious emissions, 30MHz to 20 GHz
Figure 8.3-10	AMPS	383	Emissions in base frequency range, 869 to 894 MHz
Figure 8.3-11	AMPS	799	Emissions in base frequency range, 869 to 894 MHz
Figure 8.3-12	AMPS	991	Emissions in base frequency range, 869 to 894 MHz
Figure 8.3-13	CDMA800	384	Emissions in base frequency range, 869 to 894 MHz
Figure 8.3-14	CDMA800	777	Emissions in base frequency range, 869 to 894 MHz
Figure 8.3-15	CDMA800	1013	Emissions in base frequency range, 869 to 894 MHz

Figure 8.3-1: Out of band emissions at antenna terminals – AMPS Channel 383

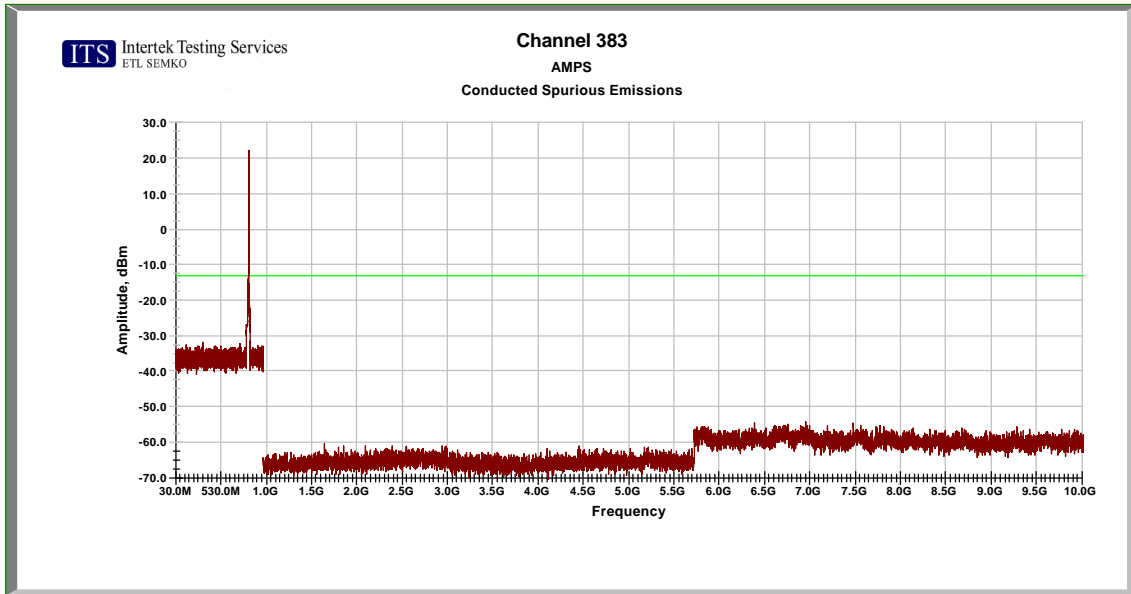

Figure 8.3-2: Out of band emissions at antenna terminals – AMPS Channel 799

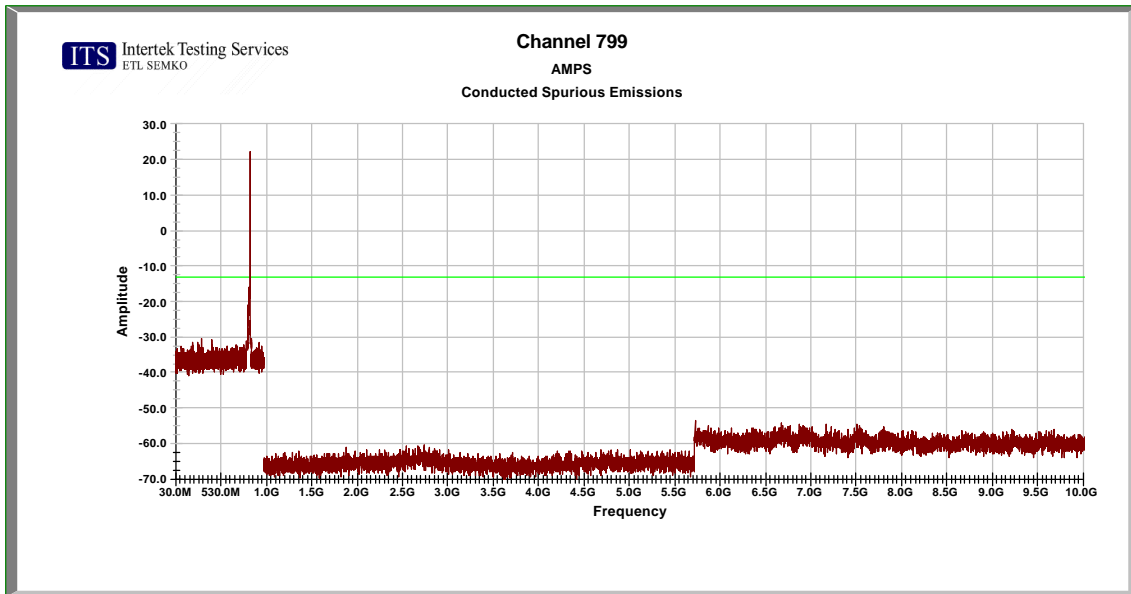

Figure 8.3-3: Out of band emissions at antenna terminals – AMPS Channel 991

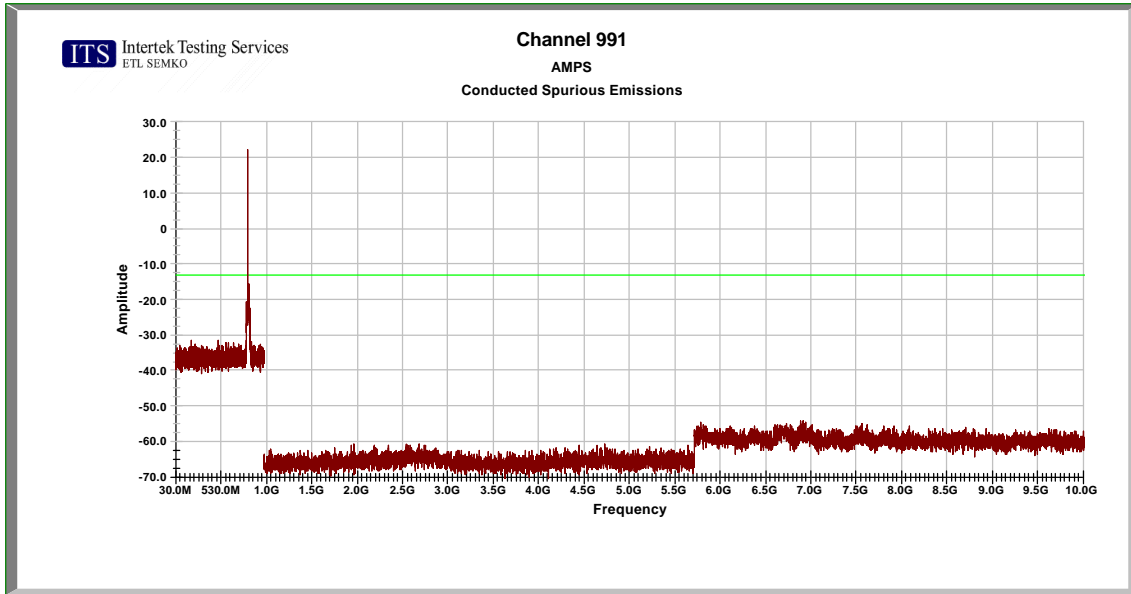

Figure 8.3-4: Out of band emissions at antenna terminals – CDMA800 Channel 384

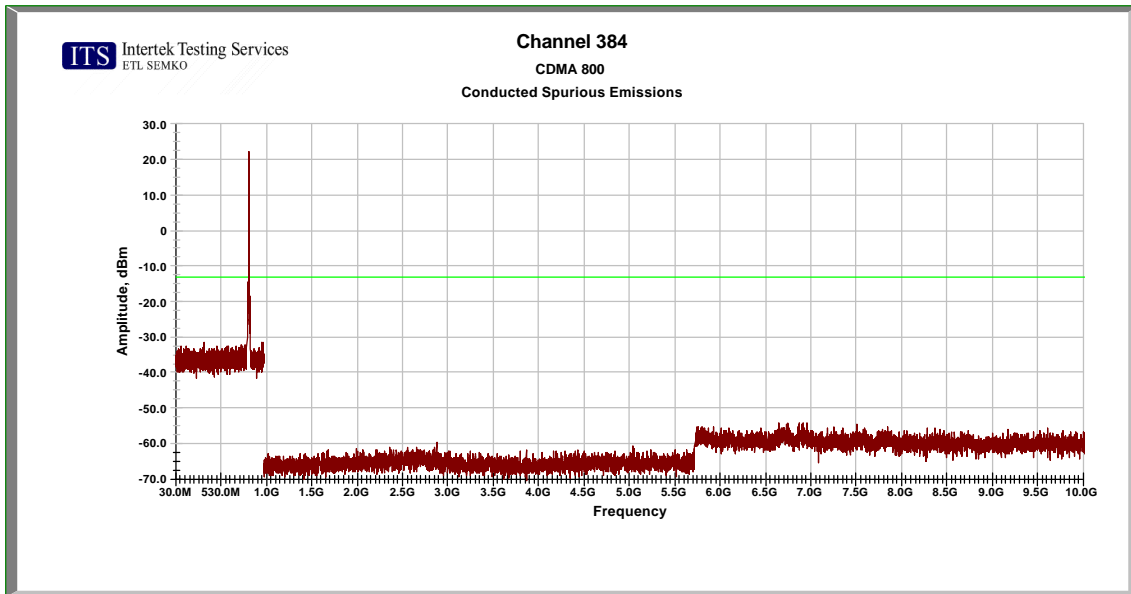

Figure 8.3-5: Out of band emissions at antenna terminals – CDMA800 Channel 777

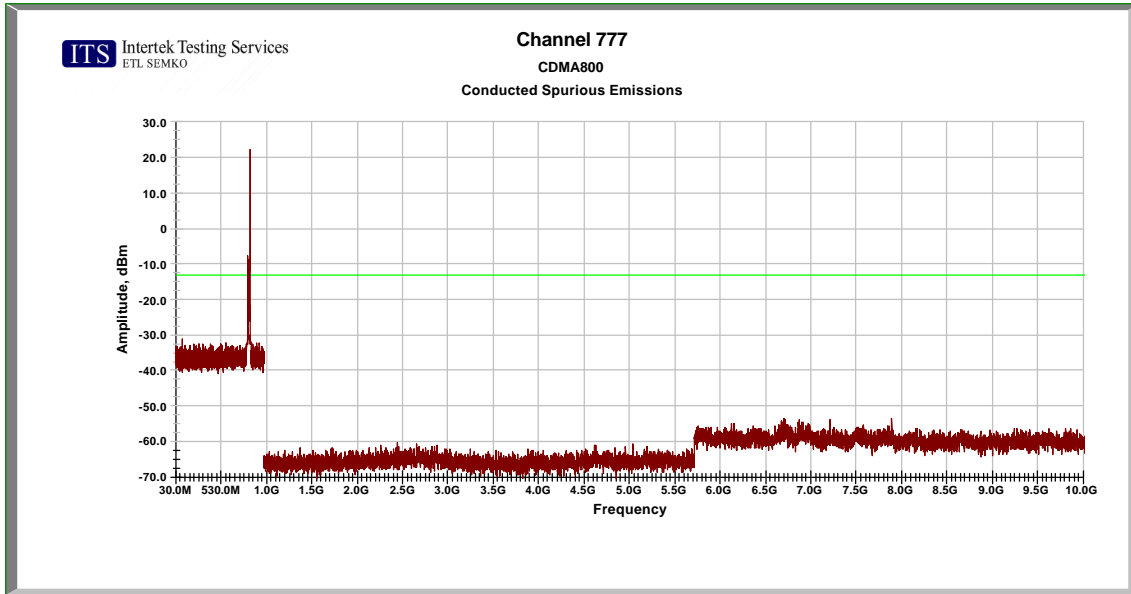

Figure 8.3-6: Out of band emissions at antenna terminals – CDMA800 Channel 1013

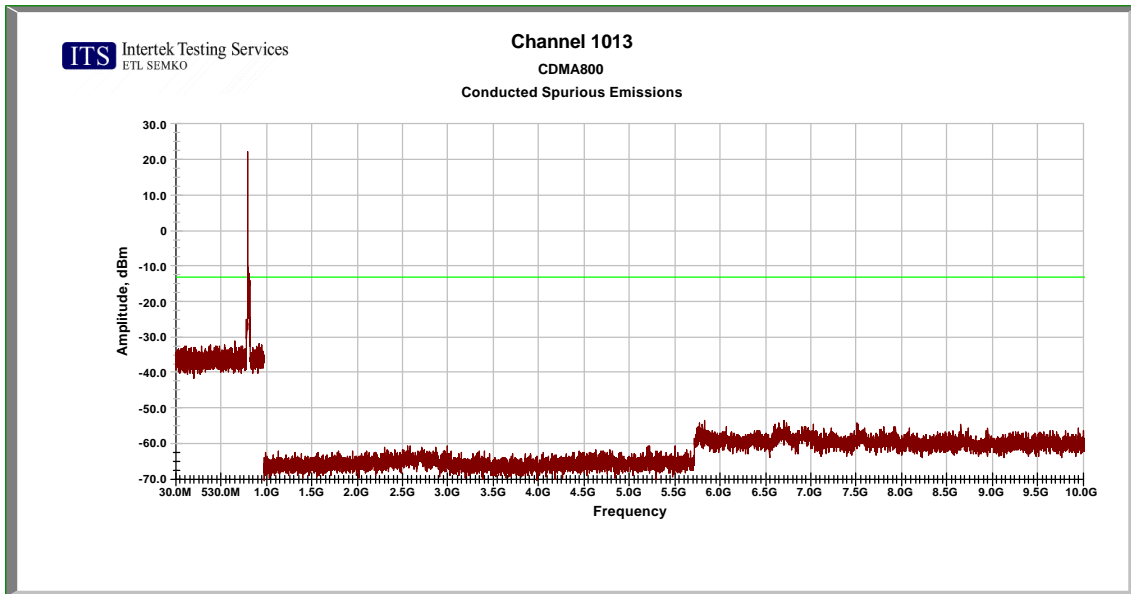

Figure 8.3-7: Out of band emissions at antenna terminals – CDMA1900 Channel 25

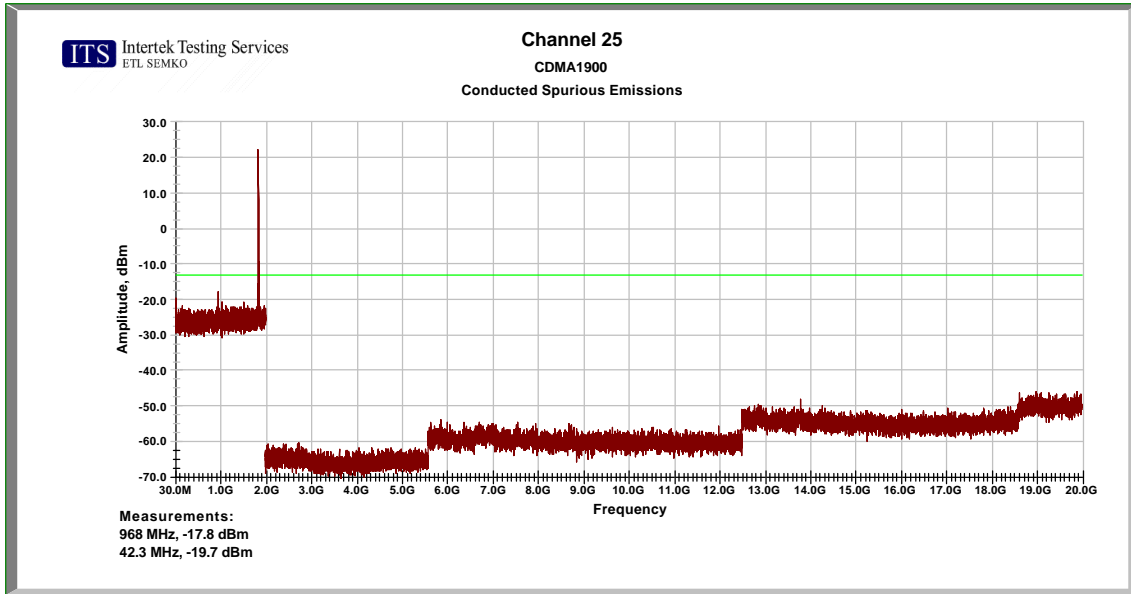

Figure 8.3-8: Out of band emissions at antenna terminals – CDMA800 Channel 600

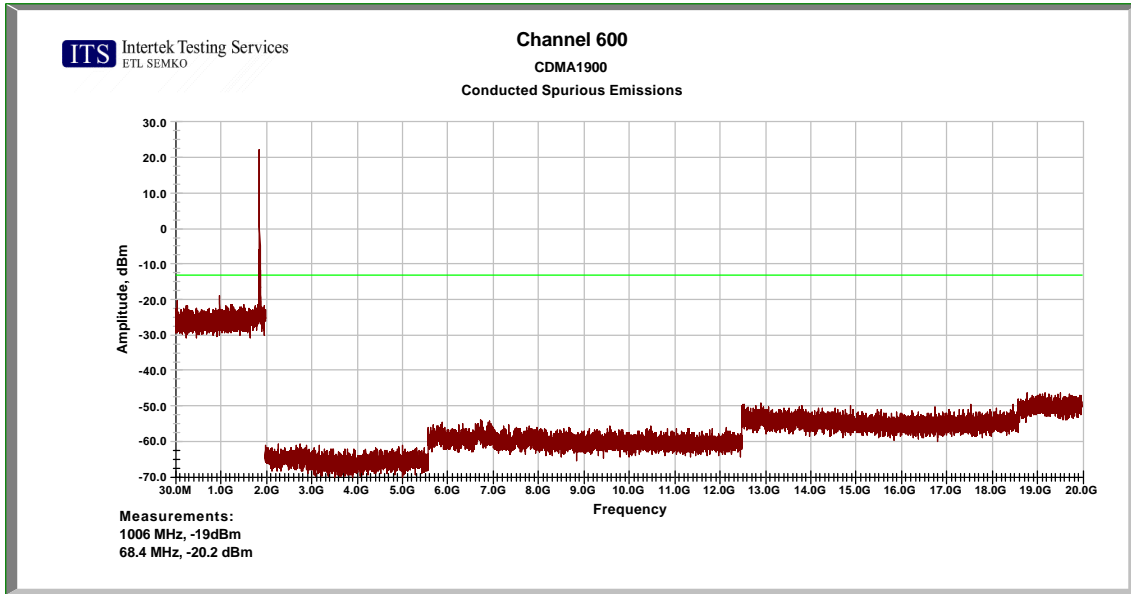

Figure 8.3-9: Out of band emissions at antenna terminals – CDMA1900 Channel 1175

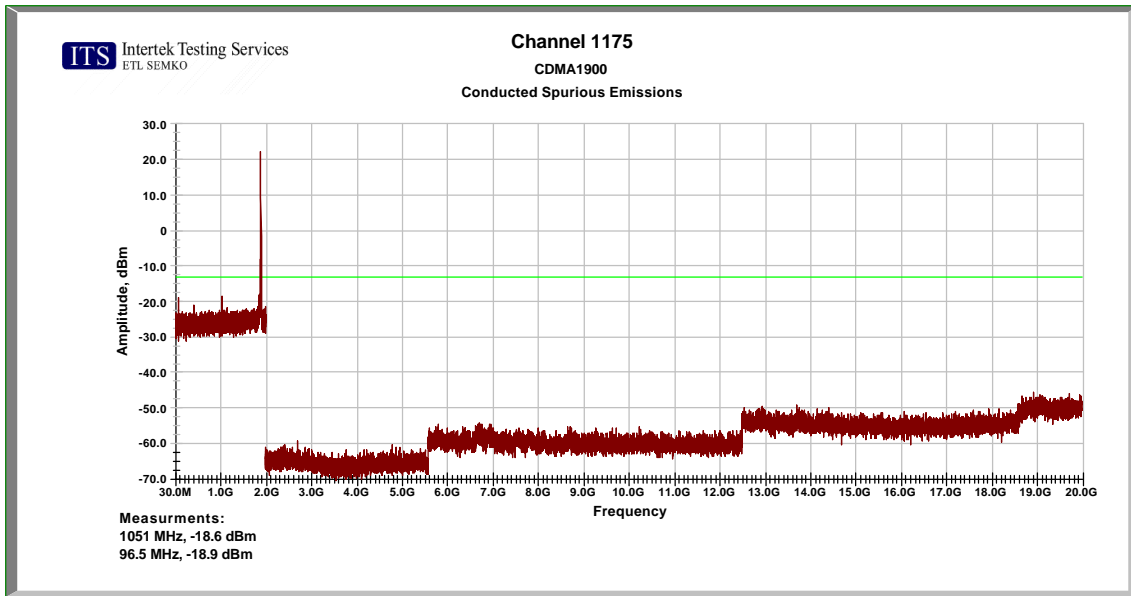
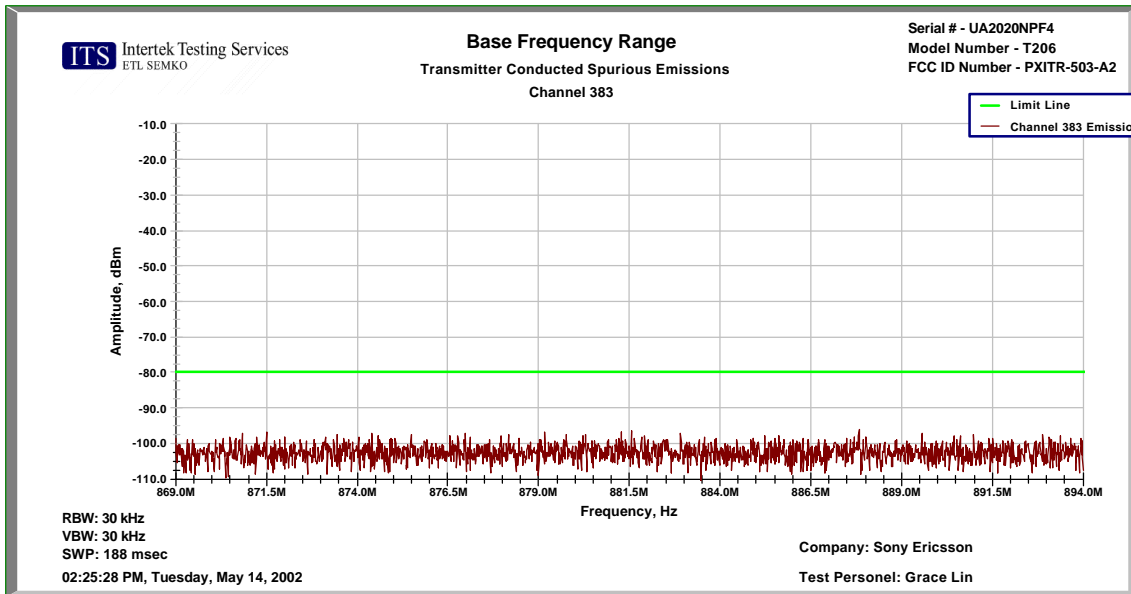

Figure 8.3-10: Emissions in base frequency range – AMPS Channel 383





# Intertek Testing Services

Figure 8.3-11: Emissions in base frequency range – AMPS Channel 799

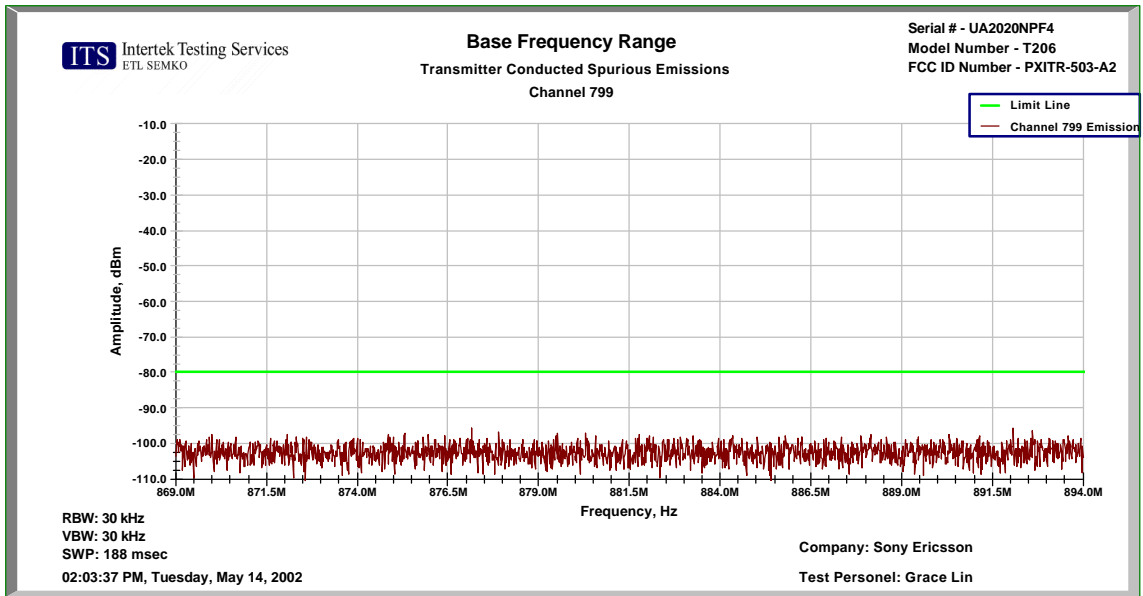

Figure 8.3-12: Emissions in base frequency range – AMPS Channel 991

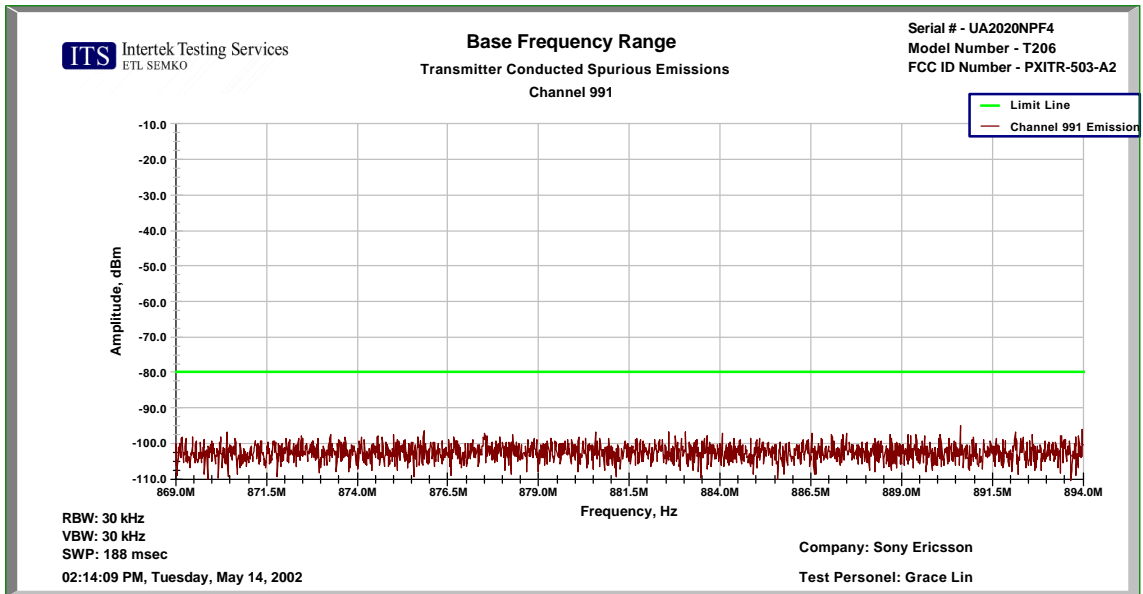

Figure 8.3-13: Emissions in base frequency range – CDMA 800 Channel 384

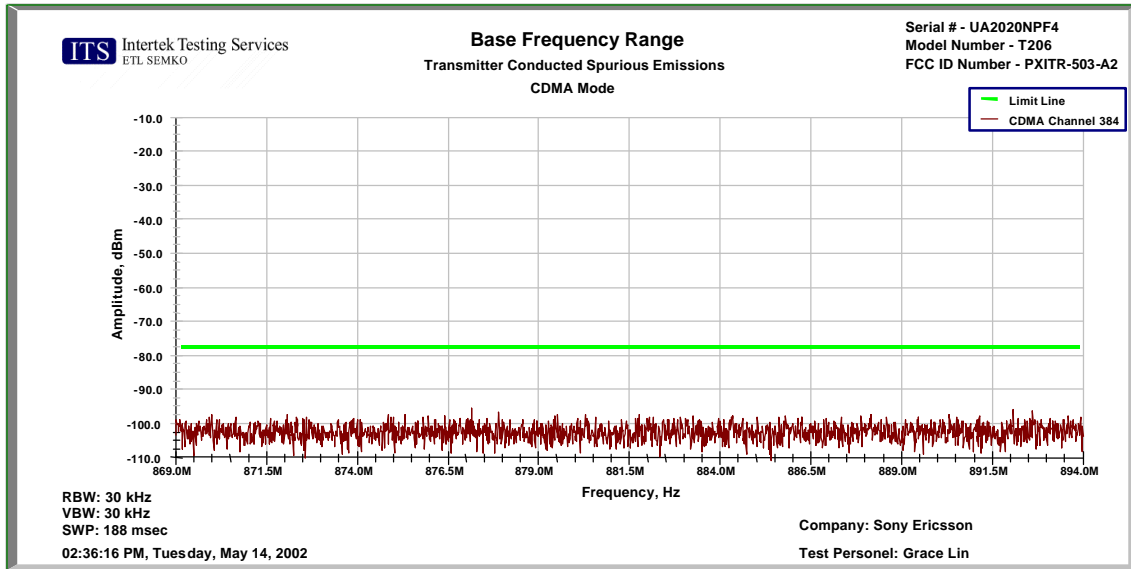

Figure 8.3-14: Emissions in base frequency range – CDMA 800 Channel 777

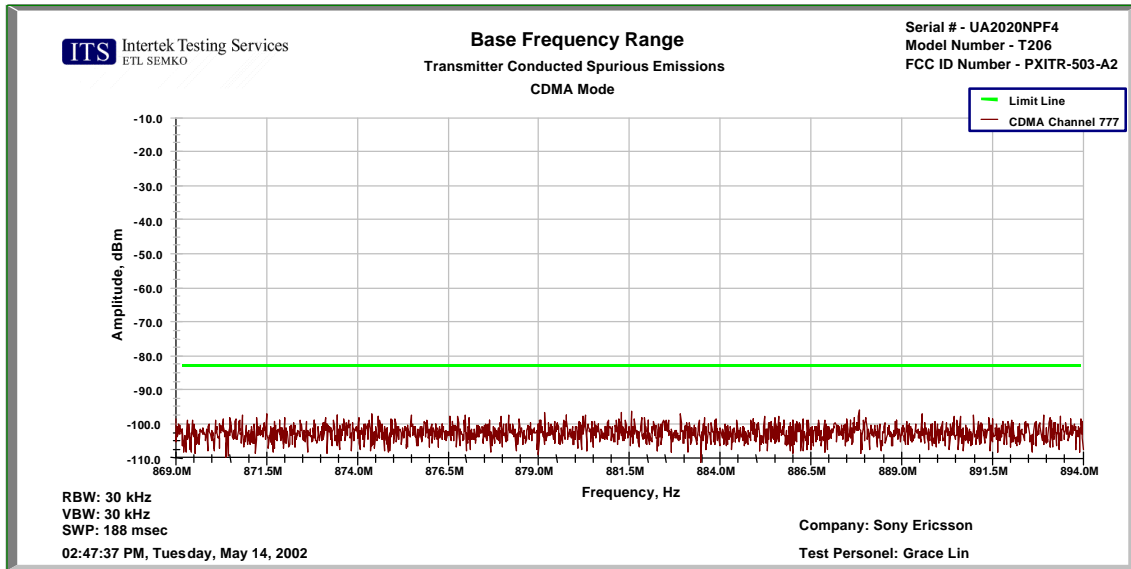
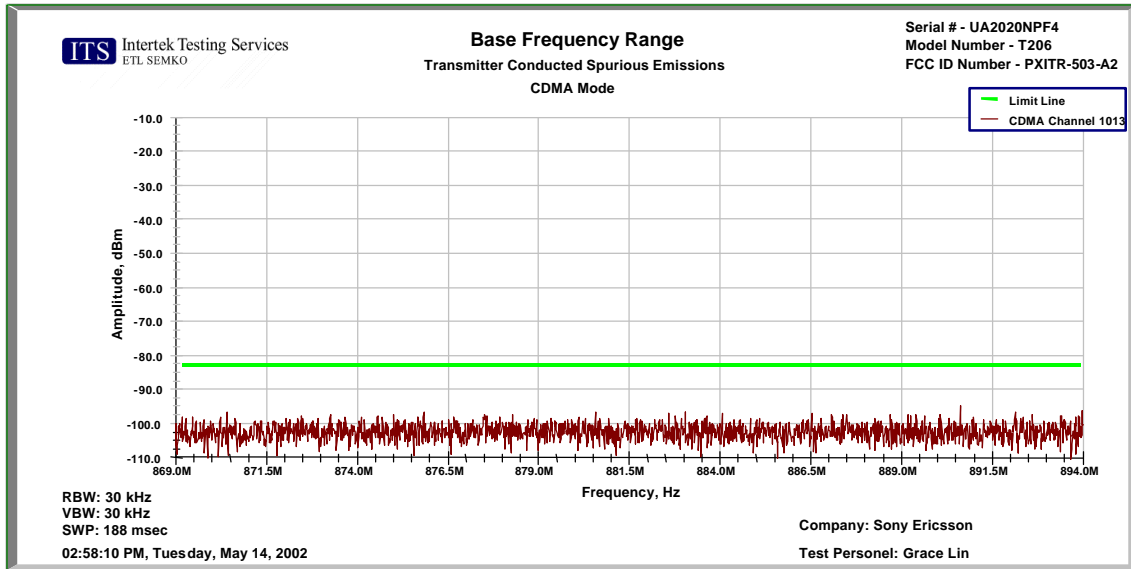

Figure 8.3-15: Emissions in base frequency range – CDMA 800 Channel 1013



**9 FIELD STRENGTH OF SPURIOUS RADIATION**

FCC §2.1053, IC RSS-129 §8.1

**9.1 Test Procedure**

The measurement antenna was placed at a distance of 3 meters from the EUT. During the tests, the antenna height and EUT azimuth were varied in order to identify the maximum level of emissions from the EUT. This maximization process was repeated with the EUT positioned in each of its three orthogonal orientations.

The frequency range up to tenth harmonic was investigated for each of three fundamental frequencies (low, middle, and high channels). Once spurious emissions were identified, the power of the emission was determined using the substitution method.

The spurious emissions attenuation was calculated as the difference between radiated power at the fundamental frequency and at the spurious emissions frequency.

**9.2 Test Equipment**

Description	Manufacturer	Model Number	Serial Number	Calibration due date
Spectrum Analyzer	HP	8566B	2134A01032/ 2344A05843	12/3/02
Spectrum Analyzer	HP	8546A	3410A00173/ 3448A00203	3/28/03
Preamplifier	HP	8447D	2648A04926	2/22/03
Preamplifier	HP	8449B	3008A00989	10/24/02
Antenna	Schaffner-Chase	CBL6112B	2622	8/14/02
High pass Filter	FILTEK	HP12/1000-5AB	ITS213156	5/6/03
High pass Filter	FILTEK	HP12/2000-5AB	ITS213156	5/6/03
Receiving Biconilog Antenna	Chase	CBL6112	2622	8/15/02
Receiving Horn Antenna	AH-Systems	SAS-200/571	246	1/13/03
Transmitting Dipole Antenna	CDI	A100	R4	8/1/02
Transmitting Horn Antenna	EMCO	3115	9208-3919	2/20/03

**9.3 Test Results**

The Dual Band Tri-mode CDMA Cellular Phone met the field strength of spurious radiation requirements of FCC §2.1053 and IC RSS-129 §8.1. The test results are located in Table 9.3-1. There were no other emissions detected within 20 dB of the limit.

# Intertek Testing Services

*Table 9.3-1: Attenuation of spurious radiation below fundamental*

Company: <b>Sony/Ericsson</b>	Tested by: Matthew Van Steen
Model: <b>T206</b>	Location: Duluth
Project No.: <b>3023646</b>	Detector: HP8546
Date: 05/07/02	Antenna: Emco3115
Notes: Antenna Pol=H	Distance: <b>3</b>

1 EUT Pos. (X,Y,Z)	2 Frequency MHz	3 Receiver reading dBuV	4 Sign Gen Level dBm	5 Antenna Gain dBi	6 EIRP dBm	7 EIRP Limit dBm	8 Margin dB
-----------------------------	-----------------------	----------------------------------	-------------------------------	-----------------------------	------------------	---------------------------	-------------------

**CDMA800 - CH. 384**

Y	1673.000	50.2	-54.1	6.5	-47.6	-13.0	-34.6
Z	2509.640	58.2	-41.9	7.6	-34.3	-13.0	-21.3

**CDMA800 - CH. 777**

X	1696.000	56.5	-47.6	6.5	-41.1	-13.0	-28.1
Z	2545.560	59.7	-45.8	7.6	-38.2	-13.0	-25.2

**CDMA800 - CH. 1013**

X	1649.040	55.2	-49.3	6.5	-42.8	-13.0	-29.8
Z	2473.440	57.2	-43.1	7.6	-35.5	-13.0	-22.5

**CDMA1900 - CH. 25**

X	3702.000	46.2	-46.3	8.2	-38.1	-13.0	-25.1
---	----------	------	-------	-----	-------	-------	-------

**CDMA1900 - CH. 600**

Z	3760.000	46.2	-45.8	8.2	-37.6	-13.0	-24.6
---	----------	------	-------	-----	-------	-------	-------

**CDMA1900 - CH. 1175**

Z	3817.000	47.2	-43.9	8.2	-35.7	-13.0	-22.7
---	----------	------	-------	-----	-------	-------	-------

**AMPS - CH. 383**

X	1672.800	62.6	-41.7	6.5	-35.2	-13.0	-22.2
Y	2509.300	64.5	-41.9	7.6	-34.3	-13.0	-21.3

**AMPS - CH. 799**

Y	1697.700	50.4	-53.7	6.5	-47.2	-13.0	-34.2
Z	2546.710	68.2	-37.4	7.6	-29.8	-13.0	-16.8

**AMPS - CH. 991**

X	1648.170	59.6	-45.0	6.5	-38.5	-13.0	-25.5
Z	2472.480	65.2	-39.1	7.6	-31.5	-13.0	-18.5

- 1 - Orthogonal orientation of EUT
- 2 - Frequency of measurement
- 3 - Highest emission from EUT recorded on receiver
- 4 - Signal generator level required to reach the highest emission from theEUT
- 5 - Substitution antenna gain, dBi
- 6 - Effective Isotopic Radiated Power, dBm (4 + 5)
- 7 - Spurious emission limit, dBm (10Log(P\*1000)-43+10Log(P))
- 8 - Margin, dB (6 - 7)

## 10 POWER LINE CONDUCTED EMISSIONS

FCC §15.107, FCC §15.207

### 10.1 Test Procedure

Measurements are carried out using quasi-peak and average detector receivers in accordance with CISPR 16. An AMN is required to provide a defined impedance at high frequencies across the power feed at the point of measurement of terminal voltage and also to provide isolation of the circuit under test from the ambient noise on the power lines. An AMN as defined in CISPR 16 shall be used.

The EUT is located so that the distance between the boundary of the EUT and the closest surface of the AMN is 0.8m.

Where a flexible mains cord is provided by the manufacturer, this shall be 1m long or if in excess of 1m, the excess cable is folded back and forth as far as possible so as to form a bundle not exceeding 0.4m in length.

The EUT is arranged and connected with cables terminated in accordance with the product specification.

Conducted disturbance is measured between the phase lead and the reference ground, and between the neutral lead and the reference ground. Both measured values are reported.

The EUT, where intended for tabletop use, is placed on a table whose top is 0.8m above the ground plane. A vertical, metal reference plane is placed 0.4m from the EUT. The vertical metal reference-plane is at least 2m by 2m. The EUT shall be kept at least 0.8m from any other metal surface or other ground plane not being part of the EUT. The table is constructed of non-conductive materials. Its dimensions are 1m by 1.5m, but may be extended for larger EUT.

Floor standing EUTs are placed on a horizontal metal ground plane and isolated from the ground plane by 3 to 12 mm of insulating material. The metal ground plane extends at least 0.5m beyond the boundaries of the EUT and has minimum dimensions of 2m by 2m.

Equipment setup for conducted disturbance tests followed the guidelines of ANSI C63.4: 1992.

### 10.2 Test Equipment

Description	Manufacturer	Model Number	Serial Number	Calibration due date
Spectrum Analyzer	HP	8566B	2134a010321/ 2344A05843	12/3/02
EMI Receiver	HP	8546A	3410A00173/ 3448A00203	3/28/03
LISN	FCC	FCC-LISN-50-50- M	2020	5/12/03

### 10.3 Test Results

The Dual Band Tri-mode CDMA Cellular Phone met the power line conducted emission requirements of FCC §15.107 and §15.207. The test results are located in Table 10.3-1.

# Intertek Testing Services

---

Table 10.3-1 FCC §15.107 and §15.207 Power line Conducted Emissions

Company: **Sony/Ericson**  
Model: **T206**  
Job No.: **3023646**  
Date: 05/08/02  
Standard: FCC15  
Class: B  
Notes:

Group: None

Tested by: Matthew Van Steen  
Location: Duluth  
Detector: HP8546  
Cable(s): CABLETT5  
Limiter: no

Frequency MHz	Reading Side A dB	Reading Side B dB	Attenuator Factor dB	System Loss dB	Quasi-Peak		
					Net dB(uV)	Limit dB(uV)	Margin dB
0.450	25.2	28.3	0.0	1.0	29.3	48.0	-18.7
0.573	22.1	28.0	0.0	1.0	29.0	48.0	-19.0
0.644	20.6	27.8	0.0	1.0	28.8	48.0	-19.2
1.000	4.1	21.5	0.0	1.0	22.5	48.0	-25.5
1.160	8.6	19.6	0.0	1.0	20.6	48.0	-27.4
1.270	8.1	16.5	0.0	1.0	17.5	48.0	-30.5

**10.4 Test Configuration Photograph**

Figure 10.4-1 and Figure 10.4-2 show the testing configurations used.

*Figure 10.4-1: Configuration photograph, AC mains conducted emission, front view*





*Figure 10.4-2: Configuration photograph, AC mains conducted emission, rear view*

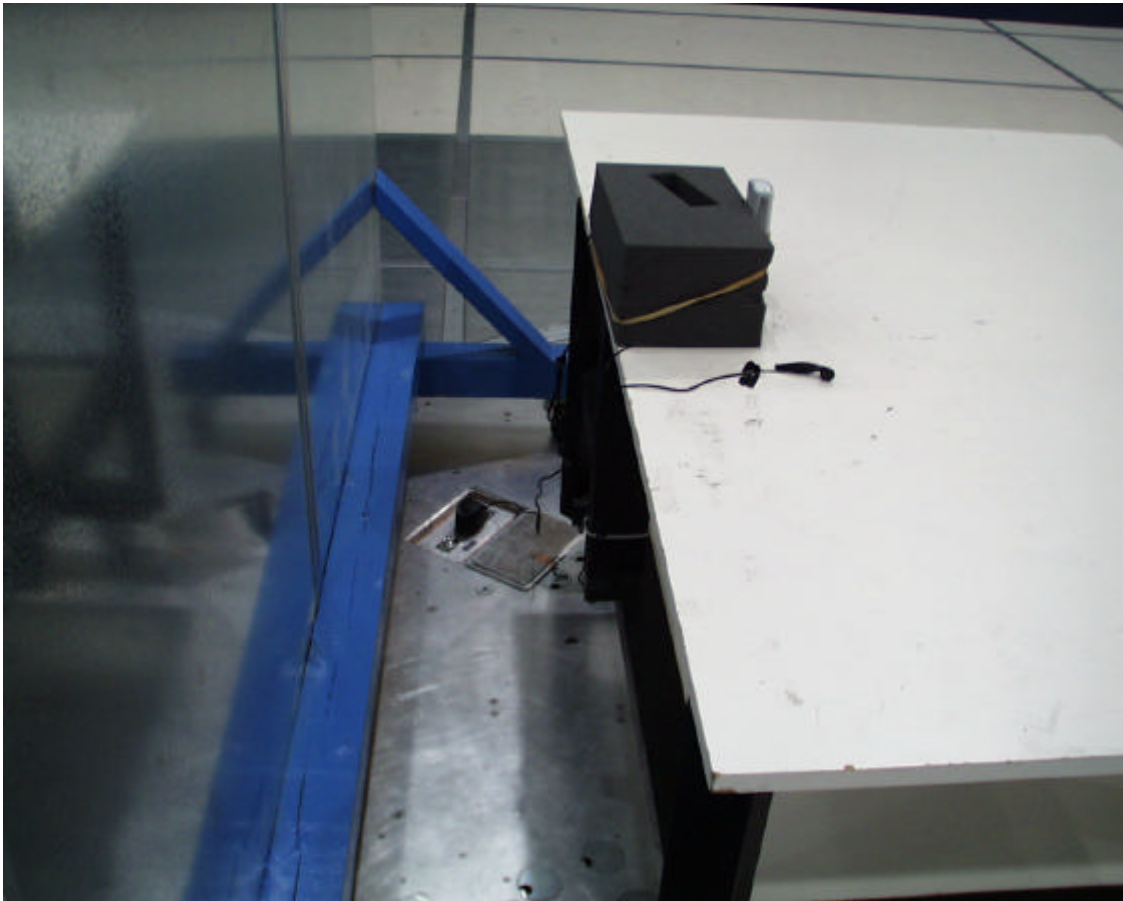

## 11 FREQUENCY STABILITY VS TEMPERATURE

FCC §2.1055, FCC §22.355, FCC §24.235, IC RSS-133 §7

Frequency tolerance: 2.5ppm

### 11.1 Test Procedure

The equipment under test was connected to an external DC power supply and the RF output was connected to a frequency counter via feedthrough attenuators. The EUT was placed inside the temperature chamber. The DC leads, RF output cable, and external PTT cable exited the chamber through an opening made for that purpose.

After the temperature stabilized for approximately 30 minutes, the external PTT switch was activated, and the frequency output was recorded from the counter.

### 11.2 Test Equipment

Description	Manufacturer	Model Number	Serial Number	Calibration due date
Spectrum Analyzer	HP	8593E	3407A01055	7/31/02
DC Power Supply	Topward	TPS-4000	Not Labeled	Calibration not required
Multimeter	Fluke	87	62150572R	11/5/02
Attenuator	Weinschel	2	BK2313	5/6/03
Temperature Chamber	Thermotron	SM-4S	505/25199RF	4/10/03

### 11.3 Test Results

The Dual Band Tri-mode CDMA Cellular Phone met the frequency stability requirements of FCC §2.1055, FCC §22.355, FCC §24.235, IC RSS-133 §7. The test results are located in Table 11.3-1 and Table 11.3-2.

# Intertek Testing Services

---

Table 11.3-1: AMPS Channel 383, Frequency stability vs. Temperature

Tx Frequency: 836.49 MHz

Tolerance: +/- 2091 Hz

Temperature (°C)	Frequency (MHz)	Difference (Hz)
60	836.490175	+175
50	836.490169	+169
40	836.490160	+160
30	836.490137	+137
20	836.490105	+105
10	836.490135	+135
0	836.490145	+145
-10	836.490145	+145
-20	836.490145	+145
-30	836.490145	+145

Table 11.3-2: CDMA1900 Channel 600, Frequency stability vs. Temperature

Tx Frequency: 1880 MHz

Tolerance: +/-4700 Hz

Temperature (°C)	Frequency (MHz)	Difference (Hz)
60	1880.000523	+524
50	1880.000426	+426
40	1880.000323	+323
30	1880.000260	+260
20	1880.000335	+335
10	1880.000355	+355
0	1880.000365	+365
-10	1880.000365	+365
-20	1880.000360	+360
-30	1880.000375	+375

## 12 FREQUENCY STABILITY VS VOLTAGE

FCC §2.1055, FCC §22.355

Frequency tolerance: 2.5ppm

### 12.1 Test Procedure

An external variable DC power supply was connected to the battery terminals of the equipment under test. The voltage was set to 115% of the nominal value and was then decreased until the transmitter light no longer illuminates; i.e., the battery end point. The output frequency was recorded for each battery voltage.

### 12.2 Test Equipment

Description	Manufacturer	Model Number	Serial Number	Calibration due date
Spectrum Analyzer	HP	8593E	3407A01055	7/31/02
DC Power Supply	Topward	TPS-4000	Not Labeled	Calibration not required
Multimeter	Fluke	87	62150572R	11/5/02
Attenuator	Weinschel	2	BK2313	5/6/03

### 12.3 Test Results

The Dual Band Tri-mode CDMA Cellular Phone met the frequency stability requirements of FCC §2.1055, FCC §22.355. The test results are located in Table 12.3-1 and Table 12.3-2.

# Intertek Testing Services

---

Table 12.3-1: AMPS Channel 383, Frequency stability vs. input voltage

Tx Frequency: 836.49 MHz  
Tolerance: +/- 2091 Hz

Supply (Battery) Volts	Frequency (MHz)	Difference ( Hz)
3.4	836.4900106	106.00
3.5	836.4900105	105.00
3.6	836.4900105	105.00
3.7	836.4900105	105.00
3.8	836.4900105	105.00
3.9	836.4900106	106.00
4.0	836.4900106	106.00
4.1	836.4900107	107.00
4.2	836.4900108	108.00

Table 12.3-2: CDMA 1900 Channel 600, Frequency stability vs. input voltage

Tx Frequency: 1880 MHz  
Tolerance: +/-4700 Hz

Supply (Battery) Volts	Frequency (MHz)	Difference ( Hz)
3.4	1880.0003550	355
3.5	1880.0003450	345
3.6	1880.0003450	345
3.7	1880.0003350	335
3.8	1880.0003350	335
3.9	1880.0003350	335
4.0	1880.0003250	325
4.1	1880.0003250	325
4.2	1880.0003150	315

**13 RECEIVER SPURIOUS EMISSION**

**13.1 Test Limits**

*Table 13.1-1 Radiated Emission Limit for FCC §15.109, IC RSS-129 §10, and IC RSS-133 §9*

Radiated Emission Limits at 3 meters	
Frequency (MHz)	Quasi-Peak limits, dB (µV/m)
30 to 88	40.0
88 to 216	43.5
216 to 960	46.0
960 and up	54.0

**13.2 Test Equipment**

Description	Make	Model	Serial #	Cal Due Date
EMI Receiver	HP	85462A	3650A00362	3/28/03
RF Filter Selector	HP	85460A	3704A00331	3/28/03
Spectrum Analyzer	HP	8566B	2134A01032 / 2344A05843	12/4/02
PreAmp	HP	8449B	3008A0089	10/24/02
BiLog Antenna	Chase	CBL6112B	2622	8/14/02
Horn Antenna	AH Systems	SAS200/571	246	1/21/03
Cable	N/A	Cable N2	ITS# 211999a2	6/7/02
Cable	N/A	CableTW2	ITS# 211411	6/7/02
Cable	N/A	CableTW3	ITS# 211412	6/7/02

**13.3 Test Procedure**

Measurements are conducted with a quasi-peak detector instrument in the frequency range of 30 MHz to 1000 MHz. The measuring receiver meets the requirements of Section One of CISPR 16 and the measuring antenna correlates to a balanced dipole.

Measurements of the radiated field are made with the antenna located at a distance of 3 meters from the EUT. If the field-strength measurements at 3m cannot be made because of high ambient noise level or for other reasons, measurements may be made at a closer distance, for example 1m. An inverse proportionality factor of 20 dB per decade should be used to normalize the measured data to the specified distance for determining compliance.

The antenna is adjusted between 1m and 4m in height above the ground plane for maximum meter reading at each test frequency.

The antenna-to-EUT azimuth is varied during the measurement to find the maximum field-strength readings.

# Intertek Testing Services

The antenna-to-EUT polarization (horizontal and vertical) is varied during the measurements to find the maximum field-strength readings.

The EUT, when intended for tabletop use, is placed on a table whose top is 0.8m above the ground plane. The table is constructed of non-conductive materials. Its dimensions are 1m by 1.5m, but may be extended for larger EUT.

Floor standing EUTs are placed on a horizontal metal ground plane and isolated from the ground plane by 3 to 12 mm of insulating material.

Equipment setup for radiated disturbance tests followed the guidelines of ANSI C63.4: 1992.

## 13.4 Test Results

The Dual Band Tri-mode CDMA Cellular Phone met the radiated disturbance requirements of FCC §15.109, IC RSS-129 §10, and IC RSS-133 §9. The test results are located in Table 13.4-1. There were no other emissions detected within 10 dB of the limit.

*Table 13.4-1 FCC §15.109, IC RSS-129 §10, and IC RSS-133 §9 Receiver Spurious Emission*

Company: <b>Sony/Ericsson</b>	Tested by: Matthew Van Steen
Model: <b>T206</b>	Location: Duluth
Project No.: <b>3023646</b>	Detector: HP8546
Date: 05/06/02	Antenna: CHAS2622
Standard: FCC15	PreAmp: HP-1G
Class: B	Group: None
Notes: Tested in CDMA 800 mode - CH 384	Cable(s): CABLETW2 CABLEN2
	Distance: <b>10</b>

Ant. Pol. (V/H)	Frequency MHz	Reading dB(uV)	Antenna Factor dB(1/m)	Cable Loss dB	Pre-amp Factor dB	Distance Factor dB	Net dB(uV/m)	Limit dB(uV/m)	Margin dB
V	691.200	26.6	18.9	5.4	26.6	-10.5	34.6	46.0	-11.4
H	691.200	27.9	18.9	5.4	26.6	-10.5	35.9	46.0	-10.1
H	576.025	23.7	18.8	5.0	26.6	-10.5	31.3	46.0	-14.7
H	537.757	24.8	17.7	4.7	26.6	-10.5	31.0	46.0	-15.0
H	835.000	17.1	19.9	5.9	26.3	-10.5	27.1	46.0	-18.9
H	499.200	22.4	17.6	4.7	26.6	-10.5	28.6	46.0	-17.4

**13.5 Test Configuration Photograph**

Figure 13.5-1 and Figure 13.5-2 show the testing configurations used.



*Figure 13.5-1: Configuration photograph, radiated emission, front view*





*Figure 13.5-2: Configuration photograph, radiated emission, rear view*