



EUROFINS PRODUCT SERVICE GMBH

TEST - REPORT

**FCC PART 15 D for Isochronous UPCS devices
RSS-213 for LE-PCS devices**

**FCC ID: PXARFP5-1G9
IC: 4604A-FP51G9**

**Test report no.:
G0M20812-2118-C-1**



Testing Cert #1983.01



Eurofins Product Service GmbH
Storkower Str. 38c, D-15526 Reichenwalde,
Germany

Phone +49-33631-888 00
Fax +49-33631-888 660

TABLE OF CONTENTS

1	General information	3
1.1	Notes	3
1.2	Testing laboratory	4
1.3	Details of approval holder	4
1.4	Application details	5
1.5	Test item	5
1.6	Test standards	7
2	TECHNICAL TEST	8
2.1	Summary of test results	8
2.2	Test environment	8
2.3	Test equipment utilized	9
3	RESULTS OF EXAMINATIONS AND TESTS	10
3.1.	Examinations and Test Procedures	11
3.1.1	Coordination with fixed microwave service, FCC 15.307 (b)	11
3.1.2	Reference to Subpart B, FCC 15.309 (b)	11
3.1.3	Conducted limits AC Power line, FCC 15.315, 15.207; RSS-213 4.2; 6.3	12
3.1.4	Antenna requirement, FCC 15.317, 15.203	13
3.1.5	Modulation techniques, FCC 15.319 (b); RSS-213 6.1	13
3.1.6	Emission bandwidth, FCC 15.323 (a); FCC 15.31 (e); RSS-213 6.4	14
3.1.7	Peak Transmit Power, FCC 15.319 (c); RSS-213 4.3.1, 6:5	16
3.1.8	Power spectral density, FCC 15.319 (d); RSS-213 4.3.1, 6:6	17
3.1.9	Directional gain of the antenna, FCC 15.319 (e); RSS-213 4.1 (e)	18
3.1.10	Automatic discontinuation of transmission, FCC 15.319 (f); RSS-213 4.3.4 (a)	19
3.1.11	Radio frequency radiation exposure, FCC 15.319 (i); RSS-Gen 5.5	20

3.1.12	Monitoring threshold; Least interfered channel; FCC 15.323 (c)(2); (c)(5) (c)(9); RSS-213 4.3.4 (b)(2)	21
3.1.13	Monitoring of intended transmit window and maximum reaction time, FCC 15.323 (c)(1); RSS-213 4.3.4 (b)(1)	24
3.1.14	Monitoring bandwidth, FCC 15.323 (c)(7); RSS-213 4.3.4 (b)(7)	26
3.1.15	Random waiting interval, FCC 15.323 (c)(6); RSS-213 4.3.4 (b)(6)	27
3.1.16	Duration of transmission, FCC 15.323 (c)(3); RSS-213 4.3.4 (b)(3)	28
3.1.17	Connection acknowledgement, Unacknowledged transmissions, FCC 15.323 (c)(4); RSS-213 4.3.4 (b)(5)	29
3.1.18	Selected channel confirmation, Segment occupancy; FCC 15.323 (c)(5)	30
3.1.19	Monitoring antenna, FCC 15.323 (c)(8); RSS-213 4.3.4 (b)(8)	31
3.1.20	Duplex connections, FCC 15.323 (c)(10); RSS-213 4.3.4 (b)(10)	32
3.1.21	Alternative monitoring interval for co-located devices, FCC 15.323 (c)(11); RSS-213 4.3.4 (b)(11)	34
3.1.22	Fair access to spectrum related to (c)(10) and (c)(11), FCC 15.323 (c)(12); RSS-213 4.3.4 (b)(12)	34
3.1.23	Spurious emission, radiated Emissions inside and outside the sub-band, FCC 15.323 (d); RSS-213 6.7	35
3.1.24	Frame period, FCC 323 (e); RSS-213 4.3.(c).	40
3.1.25	Frequency stability, FCC 323 (f); RSS-213 6.8	42
3.1.26	Receiver spurious emissions; RSS-213 6.8	43
Annex		44

1 General Information

1.1 Notes

The purpose of conformity testing is to increase the probability of adherence to the essential requirements or conformity specifications, as appropriate.

The complexity of the technical specifications, however, means that full and thorough testing is impractical for both technical and economic reasons.

Furthermore, there is no guarantee that a test sample which has Passed all the relevant tests conforms to a specification.

Neither is there any guarantee that such a test sample will interoperate with other genuinely open systems.

The existence of the tests nevertheless provides the confidence that the test sample possesses the qualities as maintained and that its performance generally conforms to representative cases of communications equipment.

The test results of this test report relate exclusively to the item tested as specified in 1.5.

The test report may only be reproduced or published in full.

Reproduction or publication of extracts from the report requires the prior written approval of the Eurofins Product Service GmbH.

Specific Conditions:

Usage of the hereunder tested device in combination with other integrated or external antennas requires at least additional output power measurements, spurious emission measurements, conducted emission measurements (AC supply lines) and radio frequency exposure evaluations for each individual configuration are performed, for certification by competent authorities FCC; IC.

This report is related to FCC Part 15 D applied to UPCS devices of which technology is derived from DECT standard.

Additional this report covers the requirement of RSS-213, 2 GHz Licence exempt Personal Communications Services Devices (LE-PCS) released by Industry Canada (IC). In following the term UPCS covers the term LE-PCS too.

Operator:

14.01.2009		W. Treffke	
_____	_____	_____	_____
Date	Eurofins -Lab.	Name	Signature

Technical responsibility for area of testing:

14.01.2009		T. Jahn	
_____	_____	_____	_____
Date	Eurofins	Name	Signature

1.2 Testing laboratory

1.2.1 Location

EUROFINS PRODUCT SERVICE GMBH
Storkower Straße 38c
D-15526 Reichenwalde b. Berlin
Germany
Telefon : +49 33631 888 00
Telefax : +49 33631 888 66

1.2.2 Details of accreditation status

DAR ACCREDITED TESTING LABORATORY
DAR-REGISTRATION NUMBER: DAT-P-268/08

RECOGNIZED NOTIFIED BODY EMC
REGISTRATION NUMBER: BNetzA-bS EMV-07/61

RECOGNIZED NOTIFIED BODY R&TTE
REGISTRATION NUMBER: BNetzA-bS-02/51-53

FCC FILED TEST LABORATORY
REG.-No. 96970

A2LA ACCREDITED TESTING LABORATORY
CERTIFICATE No. 1983.01

BLUETOOTH QUALIFICATION TEST FACILITY (BQTF)
ACCREDITED BY BLUETOOTH QUALIFICATION REVIEW BOARD

INDUSTRY CANADA FILED TEST LABORATORY
REG. No. IC 3470

1.3 Details of approval holder

Name	: Polycom Denmark ApS
Street	: Langmarksvej 34
Town	: 8700 Horsens
Country	: Denmark
Telephone	: +45 7628 1280
Fax	: +45 7560 2851
Contact	: Mr. Henrik Birch Rasmussen
Telephone	: +45 7628 1280
E-mail	: henrik.rasmussen@polycom.com

1.4 Application details

Date of receipt of application : 05.12.2008
 Date of receipt of test item : 05.12.2008
 Date of test : 11.12.2008 - 15.12.2008

1.5 Test item

Description of test item : Isochronous UPCS device, cordless phone based on DECT modified technology.

Function	
Portable part	
Base station	<input checked="" type="checkbox"/>
Repeater	

Description of test item : DECT6.0 RFP
 Type identification : RFP5 1G9
 Fixed part
 Brand Name : POLYCOM
 Software : 001
 Hardware : 001
 Serial number : Test model without serial number.
 Photos : See annex

Technical data

Frequency bands : 1920 – 1930 MHz

Operating Channel numbers	Test Frequencies	Channel center frequency (MHz)
4	F_L	1921.536
3		1923.264
2	F_M *)	1924.992
1		1926.720
0	F_U	1928.448

*) for frequency stability test and spurious emission test in RX mode only

Number of channels : 60 (in time and spectrum window, declared by manufacturer)
 Operating modes : duplex
 Type of modulation : GFSK

Max. slot type:

single slot	<input checked="" type="checkbox"/>
double slot	<input type="checkbox"/>

 Fixed point-to-point operation: Yes/No

Antenna	Type	Gain [dBi]	internal	external
1	Ceramic monopole	0	<input checked="" type="checkbox"/>	<input type="checkbox"/>
2	Ceramic monopole	0	<input checked="" type="checkbox"/>	<input type="checkbox"/>

Antenna connector : n.a.

Antenna diversity : diversity supported

Antenna	Diversity supported	
	Tx	Rx
1	<input checked="" type="checkbox"/>	<input checked="" type="checkbox"/>
2	<input checked="" type="checkbox"/>	<input checked="" type="checkbox"/>

Host device : KIRK DECT CCFP (Central Controle Fixed part); Kirk wireless server 1500.

Classification : related to radio frequency radiation exposure

Fixed Device	<input type="checkbox"/>
Mobile Device (Human Body distance > 20cm)	<input checked="" type="checkbox"/>
Portable Device (Human Body distance < 20cm)	<input type="checkbox"/>

Power supply : 48.0 V DC 120 V AC/ DC Adapter

Data connection :

Connection	used
None	<input type="checkbox"/>
PSTN	<input type="checkbox"/>
Data Networks	<input type="checkbox"/>
others	<input checked="" type="checkbox"/>

Remark: Devices intended to be connected to PSTN have to be applied for FCC PART 68 registration, in USA and for Industry Canada standard CS-03.

Manufacturer:
(if applicable)

Name : Polycom Denmark ApS
Street : Langmarksvej 34
Town : 8700 Horsens
Country : Denmark

1.6 Test standards

Technical standard : FCC PART 15, Subpart D; RSS-213

Test method and procedure: Following requirements of FCC Part 15 D, RSS-213 and ANSI C63.17-1998 (Revision Draft 3.5 ANSI-C63.17-1998 January 14, 2006 if applicable)

Additional information : The row scheme for frequency generation, radio channels, receiver parameters, synchronization procedure, and other parameters are determined by the DECT standard. Details are content of operational description provided by manufacturer.

The manufacturer declared that the device DECT6.0 RFP RFP5 1G9 is structurally identical to the DECT RFP RFP5 1G9 tested and certificated with test report number G0M20806-1827-C-1.

Reported changes to preview hardware version:

- The PCB has been changed from layer 6 to 4 layer board.
- A second LP-filter has been inserted in the TX-part of the transceiver.

Therefore a shortened test plan was created in confirmation with the manufacturer.

2 Technical test

2.1 Summary of test results

No deviations from the technical specification(s) were ascertained in the course of the tests performed.

or

The deviations were ascertained in the course of the tests performed

2.2 Test environment

Temperature	:	25°C		
Relative humidity content	:	20 ... 75 %		
Air pressure	:	86 ... 103 kPa		
Details of power supply	:	48.0 V DC	120 V AC/DC Adaptor	
Extreme conditions parameters: (manufacturer declaration)	:	test voltage - extreme	min :	43.2 V, DC
			max:	52.8 V, DC
		temperatures – extreme	min:	-10°C ¹⁾
			max:	+55°C ¹⁾

Remarks: ¹⁾ declared by manufacturer

2.3 Test equipment utilized

No.	Test equipment	Type	Manufacturer
ETS 0012	Biconical Antenna	HK 116	R & S
ETS 0013	LPD Antenna	HL 223	R & S
ETS 0014	Log Periodical Antenna	HL 025	R & S
ETS 0031	Turn table	DS 412	Heinrich Deisel
ETS 0406	Signal Generator	SML 02	R & S
ETS 0125	Reference dipole	0003126-1880	ETS Lindgren
ETS 0224C	Programmable high resolution timer counter	PM6654G	Philips
ETS 0253	Spectrum Analyzer	FSIQ 26	R & S
ETS 0267	RF Signal Generator	SMT 03	R & S
ETS 0539	Vector Signal Generator	SMIQ 03B	R & S
ETS 0288	Artificial mains	ESH2-Z5	R & S
ETS 0310	Anechoic chamber	AC 3	Frankonia
ETS 0474	EMI Test Receiver	ESCS 30	R&S
ETS 0494	Switching unit	SSCU	R & S
ETS 0495	RF Step Attenuator	RSP	R & S
ETS 0496	Spectrum Analyzer	FSP	R & S
ETS 0497	Power Meter	NRVD	R & S
ETS 0498	Diode Power Sensor	NRV-Z1	R & S
ETS 0500	Signal Generator	SMIQ03	R & S
ETS 0501	Signal Generator	SMIQ03	R & S
ETS 0502	Power Splitter	DS-808-4	Macom

3 RESULTS OF EXAMINATIONS AND TESTS (enclosure)

TEST CASE	FCC Rules	RSS-213	Required	Customer Declaration	Test passed	Test failed
Coordination with fixed microwave service	15.307 (b)		<input checked="" type="checkbox"/>	<input checked="" type="checkbox"/>	<input type="checkbox"/>	<input type="checkbox"/>
Reference to Subpart B	15.309 (b)		<input type="checkbox"/>	<input type="checkbox"/>	<input type="checkbox"/>	<input type="checkbox"/>
Conducted limits AC Power line	15.315 , 15.207	4.2;6.3	<input type="checkbox"/>	<input type="checkbox"/>	<input type="checkbox"/>	<input type="checkbox"/>
Antenna requirement	15.317, 15.203		<input checked="" type="checkbox"/>	<input checked="" type="checkbox"/>	<input type="checkbox"/>	<input type="checkbox"/>
Modulation techniques	15.319 (b)	6.1	<input checked="" type="checkbox"/>	<input checked="" type="checkbox"/>	<input type="checkbox"/>	<input type="checkbox"/>
Emission bandwidth	15.323 (a)	6.4	<input checked="" type="checkbox"/>	<input type="checkbox"/>	<input checked="" type="checkbox"/>	<input type="checkbox"/>
Peak Transmit Power	15.319 (c)	4.3.1;6.5	<input checked="" type="checkbox"/>	<input type="checkbox"/>	<input checked="" type="checkbox"/>	<input type="checkbox"/>
Power spectral density	15.319 (d)	4.3.1;6.6	<input type="checkbox"/>	<input type="checkbox"/>	<input type="checkbox"/>	<input type="checkbox"/>
Directional gain of the antenna	15.319 (e)	4.1 (e)	<input checked="" type="checkbox"/>	<input checked="" type="checkbox"/>	<input type="checkbox"/>	<input type="checkbox"/>
Automatic discontinuation of transmission	15.319 (f)	4.3.4 (a)	<input checked="" type="checkbox"/>	<input checked="" type="checkbox"/>	<input type="checkbox"/>	<input type="checkbox"/>
Radio frequency radiation exposure	15.319 (i)	RSS – 102 Gen 5.5	<input checked="" type="checkbox"/>	<input type="checkbox"/>	<input checked="" type="checkbox"/>	<input type="checkbox"/>
Monitoring threshold	15.323(c)(2); (c)(9)	4.3.4 (b)(2)	<input type="checkbox"/>	<input type="checkbox"/>	<input type="checkbox"/>	<input type="checkbox"/>
Monitoring of intended transmit window and maximum reaction time	15.323(c)(1)	4.3.4 (b)(1)	<input type="checkbox"/>	<input type="checkbox"/>	<input type="checkbox"/>	<input type="checkbox"/>
Monitoring bandwidth	15.323 (c)(7)	4.3.4 (b)(7)	<input type="checkbox"/>	<input type="checkbox"/>	<input type="checkbox"/>	<input type="checkbox"/>
Random waiting interval,	15.323 (c)(6)	4.3.4 (b)(6)	<input type="checkbox"/>	<input type="checkbox"/>	<input type="checkbox"/>	<input type="checkbox"/>
Duration of transmission,	15.323 (c)(3)	4.3.4 (b)(3)	<input type="checkbox"/>	<input type="checkbox"/>	<input type="checkbox"/>	<input type="checkbox"/>
Connection acknowledgement,	15.323 (c)(4)	4.3.4 (b)(4)	<input type="checkbox"/>	<input type="checkbox"/>	<input type="checkbox"/>	<input type="checkbox"/>
Selected channel confirmation, power accuracy, segment occupancy	15.323 (c)(5)	4.3.4 (b)(5)	<input type="checkbox"/>	<input type="checkbox"/>	<input type="checkbox"/>	<input type="checkbox"/>
Monitoring antenna	15.323 (c)(8)	4.3.4 (b)(8)	<input type="checkbox"/>	<input type="checkbox"/>	<input type="checkbox"/>	<input type="checkbox"/>
Duplex connections	15,323 (c)(10)	4.3.4 (b)(10)	<input type="checkbox"/>	<input type="checkbox"/>	<input type="checkbox"/>	<input type="checkbox"/>
Alternative monitoring interval for co-located devices	15.323 (c)(11)	4.3.4 (b)(11)	<input type="checkbox"/>	<input type="checkbox"/>	<input type="checkbox"/>	<input type="checkbox"/>
Fair access to spectrum related to (c)(10) and (c)(11)	15.323 (c)(12)	4.3.4 (b)(12)	<input checked="" type="checkbox"/>	<input checked="" type="checkbox"/>	<input type="checkbox"/>	<input type="checkbox"/>
Spurious emission	15.209		<input checked="" type="checkbox"/>	<input type="checkbox"/>	<input checked="" type="checkbox"/>	<input type="checkbox"/>
Emissions inside and outside the sub-band	15.323 (d)	6.7	<input checked="" type="checkbox"/>	<input type="checkbox"/>	<input checked="" type="checkbox"/>	<input type="checkbox"/>
Frame period	15.323 (e)	4.3.4 (c)	<input checked="" type="checkbox"/>	<input type="checkbox"/>	<input checked="" type="checkbox"/>	<input type="checkbox"/>
Frequency stability	15.323 (f)	6.2	<input checked="" type="checkbox"/>	<input type="checkbox"/>	<input checked="" type="checkbox"/>	<input type="checkbox"/>
Receiver spurious emissions		6.8	<input checked="" type="checkbox"/>	<input type="checkbox"/>	<input checked="" type="checkbox"/>	<input type="checkbox"/>

Test Report No.: G0M20812-2118-C-1

3.1 Examinations and Test Procedures

The test procedures are performed following the requirements of FCC Part 15, RSS-213 and test standard ANSI C63.17-1998 [American National Standard for Methods of Measurement of the Electromagnetic and Operational Compatibility of Unlicensed Personal Communications Services (UPCS) Devices] and Revision Draft 3.5 ANSI-C63.17-1998 January 14, 2006 if applicable.

3.1.1 Coordination with fixed microwave service, FCC 15.307 (b)

For USA UTAM, Inc., is designated to coordinate and manage the transition of the 1910 – 1930 MHz band from Private Operational-Fixed Microwave Service (OFS) operating under Part 94 of this Chapter to unlicensed PCS operations.

Therefore each applicant for certification operating under the provisions of this Subpart must be accompanied by an affidavit from UTAM, Inc. certifying that the applicant is a participating member of UTAM, Inc.

The affidavit from UTAM Inc. is attached in Annex	<input type="checkbox"/>
The applicant will provide the affidavit from UTAM Inc. later in the course of certification by TCB or FCC	<input checked="" type="checkbox"/>

3.1.2 Reference to Subpart B, FCC 15.309 (b)

For USA the requirements of Subpart D apply only to the radio transmitter contained in the PCS device. Other aspects of the operation of a PCS device may be subject to requirements contained elsewhere in this Chapter. In particular, a PCS device that includes digital circuitry not direct associated with the radio transmitter also is subject to the requirements for unintentional radiators in Subpart B, For Canada unintentional radiators, other than radio receivers, are regulated by the Departments Interference Causing Equipment Standards.

Test procedures: FCC Part 15B, ICES - 003

This requirement is not applicable because the test sample does not include digital circuitry which is not direct associated with the radio transmitter	<input checked="" type="checkbox"/>
For test results according to FCC 15B and / or ICES – 003 see Appendix C	<input type="checkbox"/>
This requirement is covered by results of radiated emission test according to FCC 15.323(d) and / or RSS – 213 6.7	<input type="checkbox"/>

3.1.3 Conducted limits AC Power line, FCC 15.315, 15.207; RSS-213 4.2, 6.3 / RSS – Gen 7.2.2

For an intentional radiator which is designed to be connected to the public utility (AC) power line, the radio frequency voltage that is conducted back onto the AC line on any frequency or frequencies within the band 150 kHz to 30 MHz shall not exceed the limits in the table below. Compliance with this provision shall be based on the measurement of the radio frequency voltage between each power line and ground at the power terminals.

This measurement was transact first with instrumentation using an average and peak detector and a 10 kHz bandwidth. If the peak detector achieves a calculated level, the measurement is repeated by an instrumentation using a quasi-peak detector.

Test equipment used: ETS 0125; ETS 0288; ETS 0474

Frequency	Level	
	quasi-peak	average
150 kHz	--	--

Limits:

Frequency of Emission (MHz)	Conducted Limit (dBuV)	
	Quasi Peak	Average
0.15-0.5	66 to 56	56 to 46
0.5-5	56	46
5-30	60	50

Verdict:

Pass	Fail
<input type="checkbox"/>	<input type="checkbox"/>

Comment: Not required.

3.1.4 Antenna requirement, FCC 15.317, 15.203

For USA an UPCS device must meet the antenna requirement of Section 15.203.

Outcome of visual inspection:

This unit uses internal antennas. There is no provision for an external antenna.	<input checked="" type="checkbox"/>
This unit uses an unique antenna jack for connection to dedicated external antenna	<input type="checkbox"/>
This unit has an external antenna which is fix attached.	<input type="checkbox"/>
This unit with its antenna will be professionally installed as described in manufacturers description.	<input type="checkbox"/>

See Annex A for pictures.

In this arrangement the EUT fulfils the requirements of FCC 15.203.

3.1.5 Modulation techniques, FCC 15.319 (b); RSS-213 6.1

All transmissions must use only digital modulation.

The test sample is an isochronous digital modulated device that operates in 1920-1930 MHz band. This device bases on DECT technology described in European Standards EN 300 175-2 and EN 300 175-3, now operating in frequency channels mentioned before on sub-clause 1.5.

The operating modes are MC/TDMA/TDD (Multi carrier / Time Division Multiple Access / Time Division Duplex) using Digital GFSK modulation.

For further details see operational description provided by manufacturer.

3.1.6 Emission bandwidth, FCC 15.323 (a); RSS 213 6.4

Operation will be contained within the 1920 – 1930 MHz band. The emission bandwidth shall be less than 2.5 MHz, but in no event the emission bandwidth shall be less than 50 kHz.

Emission bandwidth is measured according to ANSI 63.17 sub-clause 6.1.3 using test set-up no. 1.

$f_x = 1921.54 \text{ MHz}$			
ΔP	$f_{(low)}$	$f_{(high)}$	$\Delta f = f_{(high)} - f_{(low)}$
-26	1920.814	1922.21	1.40
-12	1920.974	1922.002	1.04
-6	1921.096	1921.554	0.46

$f_x = 1924.99 \text{ MHz}$			
ΔP	$f_{(low)}$	$f_{(high)}$	$\Delta f = f_{(high)} - f_{(low)}$
-26	1924.284	1925.640	1.38
-12	1924.472	1925.400	0.93
-6	1924.564	1924.998	0.43

$f_x = 1928.45 \text{ MHz}$			
ΔP	$f_{(low)}$	$f_{(high)}$	$\Delta f = f_{(high)} - f_{(low)}$
-26	1927.724	1929.162	1.43
-12	1927.906	1928.918	1.01
-6	1928.006	1928.482	0.48

Occupied Bandwidth (99%) – RSS Gen

Test conditions	Channel 4	Channel 2	Channel 0
	MHz	MHz	MHz
$T_{nom} = 25 \text{ }^\circ\text{C}$ $V_{nom} =$	--	--	--
Measurement uncertainty	< 10 Hz		

Limit:

Δf_{\min} (-26dB)	>	50 KHz
Δf_{\max} (-26dB)	<	2.5 MHz

Verdict:

Pass	Fail
<input checked="" type="checkbox"/>	<input type="checkbox"/>

For measurements diagrams see Annex B

Test set-up 1 – General equipment configuration for conducted RF tests

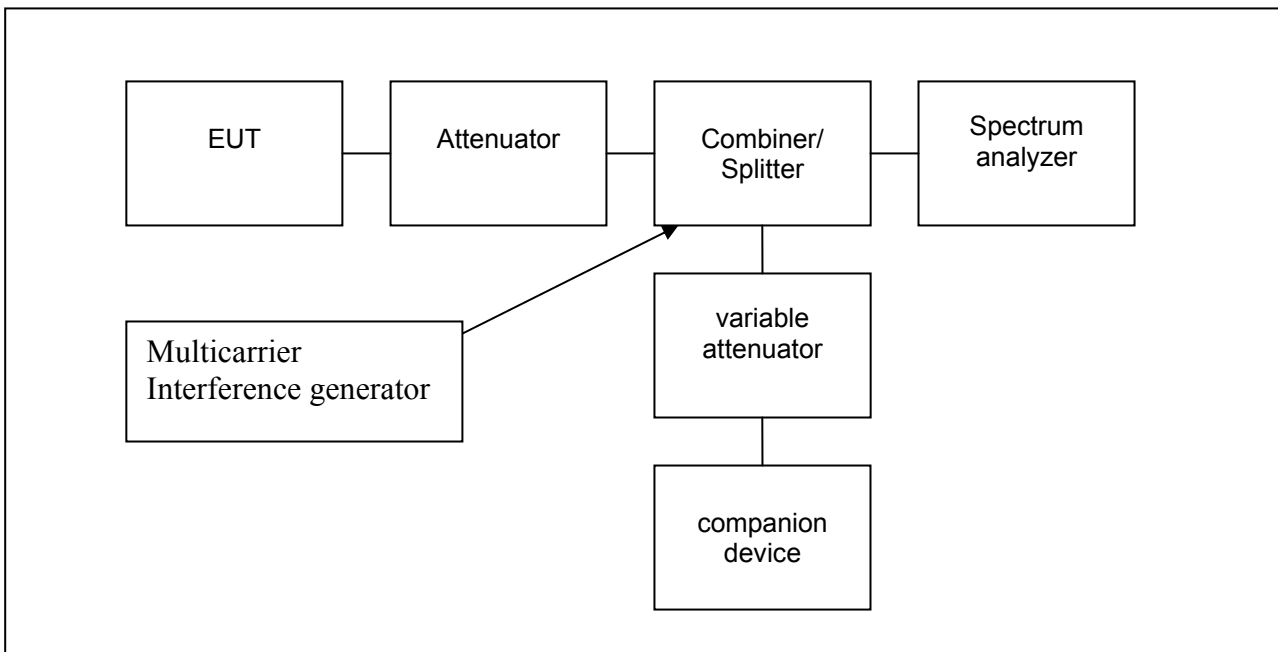
 Test equipment used: EZS 0267, ETS 0406, ETS 0495, ETS 0496, ETS 0500, ETS 0501;
 ETS 0502, ETS 0539

3.1.7 Peak transmit power, FCC 15.319 (c), FCC 15.31(e); RSS-213 4.3.1, 6.5

Peak transmit power shall not exceed 100 microwatts multiplied by the square root of the emission bandwidth in hertz. Peak transmit power must be measured over any interval of continuous transmission using instrumentation calibrated in terms of an rms-equivalent voltage. The measurement results shall be properly adjusted for any instrument limitations, such as detector response times, limited resolution bandwidth capability when compared to the emission bandwidth, sensitivity, etc., so as to obtain a true peak measurement for the emission in question over the full bandwidth of the channel.

The Peak transmit Power is measured according to ANSI 63.17 sub-clause 6.1.2. using test set-up No. 1. The limit for Peak Transmit Power has to be calculated according to following formula using the emission bandwidth measured before and the directional antenna gain.

$$\begin{aligned} \text{PTP} &= 100\mu\text{W} \times \sqrt{\text{EBW}} \\ \text{when } G_A \leq g & \quad \text{PTP} = 100\mu\text{W} \times \sqrt{\text{EBW} - (G_A - g)} \end{aligned}$$

EBW = emission bandwidth [Hz]

G_A = EUT antenna gain [dBi]

g = Allowable excess gain over that of an isotropic antenna without a transmit power reduction [$g = 3$ dB, acc. to FCC 15.319 (e)] and / or RSS-213 4.1(e)

The directional gain of used antenna has to be considered.

The test is performed with the variation of supply voltage of +/- 15% for FP. For PP a full battery is used. For devices with transmitter antenna diversity is checked that the feeding way to all antennas is identical. Therefore one conducted PTP measurements is sufficient.

Results:

On the attached diagrams PEAK AVG represents the related measurement value determined by values in time between T1 and T2.

Frequency [MHz]	Power [dBm]		
	for U_{nom}	for U_{max}	for U_{min}
F_L	19.89	--	--
F_H	19.76	--	--

Limit:

EBW [MHz]	Max. power [dBm]	Corrected by antenna gain > 3 dBi
1.43	20.73	--

Verdict:

Pass	Fail
<input checked="" type="checkbox"/>	<input type="checkbox"/>

For measurements diagrams see Annex C

3.1.8 Power spectral density, FCC 15.319 (d); RSS-213 4.3.2.1, 6.6

Power spectral density shall not exceed 3 mW in any 3 kHz bandwidth as measured with a spectrum analyzer having a resolution bandwidth of 3 kHz.

Power spectral density is measured according to ANSI 63.17 sub-clause 6.1.5 using test set-up No. 1.

Max Hold function is applied to Max Peak detector with used sweep time as long as no changes on the curve are visible.

Results:

Frequency [MHz]	Power density [mW/3kHz]
F_L	--
F_H	--

Limit:

Power spectral Density	Test condition
3 mW = 4.77 dBm	3 kHz bandwidth

Verdict:

Pass	Fail
<input type="checkbox"/>	<input type="checkbox"/>

3.1.9 Directional gain of antenna, FCC 15.319 (e), RSS 213 4.1(e)

The peak transmit power shall be reduced by the amount in decibels that the maximum directional gain of the antenna exceeds 3 dBi.

Procedure: Consideration of antenna gain value provided by manufacturer or additional radiated test of Peak transmit power.

Max antenna gain [dBi]	Reduction of power (if antenna gain > 3 dBi)
0	0

The antenna gain value is derived from:

Manufacturer declaration	<input checked="" type="checkbox"/>
Antenna diagram	<input type="checkbox"/>
Measured gain of complete system	<input type="checkbox"/>

Comment: Manufacturer declaration documents or Antenna diagrams will be considered in course of certification by responsible authority.

**3.1.10 Automatic discontinuation of transmission, FCC 15.319 (f);
RSS-213 4.3.4 (a)**

The device shall automatically discontinue transmission in case of either absence of information to transmit or operational failure. These provisions are not intended to preclude transmission of control and signaling information or use of repetitive codes used by certain digital technologies to complete frame or burst intervals.

FP repetitive codes are allowed	<input checked="" type="checkbox"/>
PP	<input type="checkbox"/>

Automatic break off the transmission means break off of connection and break of transmissions which are not control and signaling information or receptive codes of complete frame or burst intervals. In case of devices using basics of DECT technology at least fixed parts and repeaters are using control and signaling information without direct connection to their remote station.

Evaluation		Verdict
Test according to a)	<input type="checkbox"/>	--
Assessment of manufacturer declaration	<input checked="" type="checkbox"/>	Pass

a) The tests are done after establishment of a connection to counter part.

	Test case	Reaction of EUT	Verdict
1	Switch – off counterpart	B	Pass
2	Hook-on by counterpart	B	Pass
3	Switch- off by EUT	B	Pass
4	Hook -on on EUT side	B	Pass
5	Remove power from EUT	A	Pass
6	Remove power from counterpart	B	Pass

- A – Connection break down, cease of transmit
- B – Connection break down, EUT transmits signaling information
- C – Connection break down, counterpart transmits signaling information

Comment: Manufacturer declaration documents will be considered in course of certification by responsible authority.

3.1.11 Radio frequency radiation exposure, FCC 15.319 (i); RSS-102

UPCS devices are subject to the radio frequency radiation exposure requirements specified in FCC parts 1.1307 (b), 2.1091, 2.1093 and RSS-102, as appropriate. All equipment shall be considered to operate in a “general population / uncontrolled environment. For portable devices tests according to IEEE 1528 are requested, if applicable.

Consideration of radio frequency radiation exposure for EUT is done as

SAR test acc. IEEE 1528	<input type="checkbox"/>
MPE calculation as below	<input checked="" type="checkbox"/>

SAR test results: not applicable

MPE calculation:

Please find radiated power test results in Appendix C.

The EUT is considered as a mobile device according to OET Bulletin 65, Edition – 97 – 01. Therefore distance to human body of min. 20 cm is determined.

The internal / external antennas used for this mobile transmitter must provide a separation distance of at least 20 cm from all persons and must not be co-located or operating in conjunction with any other antenna or transmitter.

A safety statement concerning minimum separation distances from enclosure of the device will be integrated in the user’s manual to provide end-users with transmitter operating conditions for satisfying RFE exposure compliance.

Formula:

$$S = \text{EIRP} / 4\pi R^2$$

Calculation:

EIRP	Radiated Power [dBm]	21.89
EIRP	Radiated Power [mW]	154,525
R	Distance [cm]	20
S	Power Density [mW/cm ²]	0.031

Limit:

The limit of Power density for General Population / Uncontrolled Exposure is 1.0 mW/cm². Compliance with the requirements will be considered by calculation of power density derived from radiated power value.

Verdict:

Pass	Fail
<input checked="" type="checkbox"/>	<input type="checkbox"/>

3.1.12 Monitoring threshold; Least interfered channel; FCC 15.323 (c)(2); (c)(5); (c)(9); RSS-213 4.3.4 (b)(2)

The lower monitoring threshold for EUTs without LIC procedure (least interfered channel) must not be more than 30 dB above the thermal noise power for a bandwidth equivalent to the emission bandwidth of the device.

Devices that have a power output lower than the maximum permitted under the rules can increase their monitoring detection threshold by one decibel for each one decibel that the transmitter power is below the maximum permitted.

For EUTs which support least interfered channel procedure (LIC) there is no need to measure the lower threshold because the rule 15.323(c)(2) is automatically met by the LIC procedure. For EUTs with 40 and more logical channels the upper threshold is applicable.

Monitoring threshold is measured according to Revision Draft ANSI 63.17 sub-clause 7.1, 7.2, 7.3 using test set-up No. 2.

This test set-up is used for most tests related to monitoring.

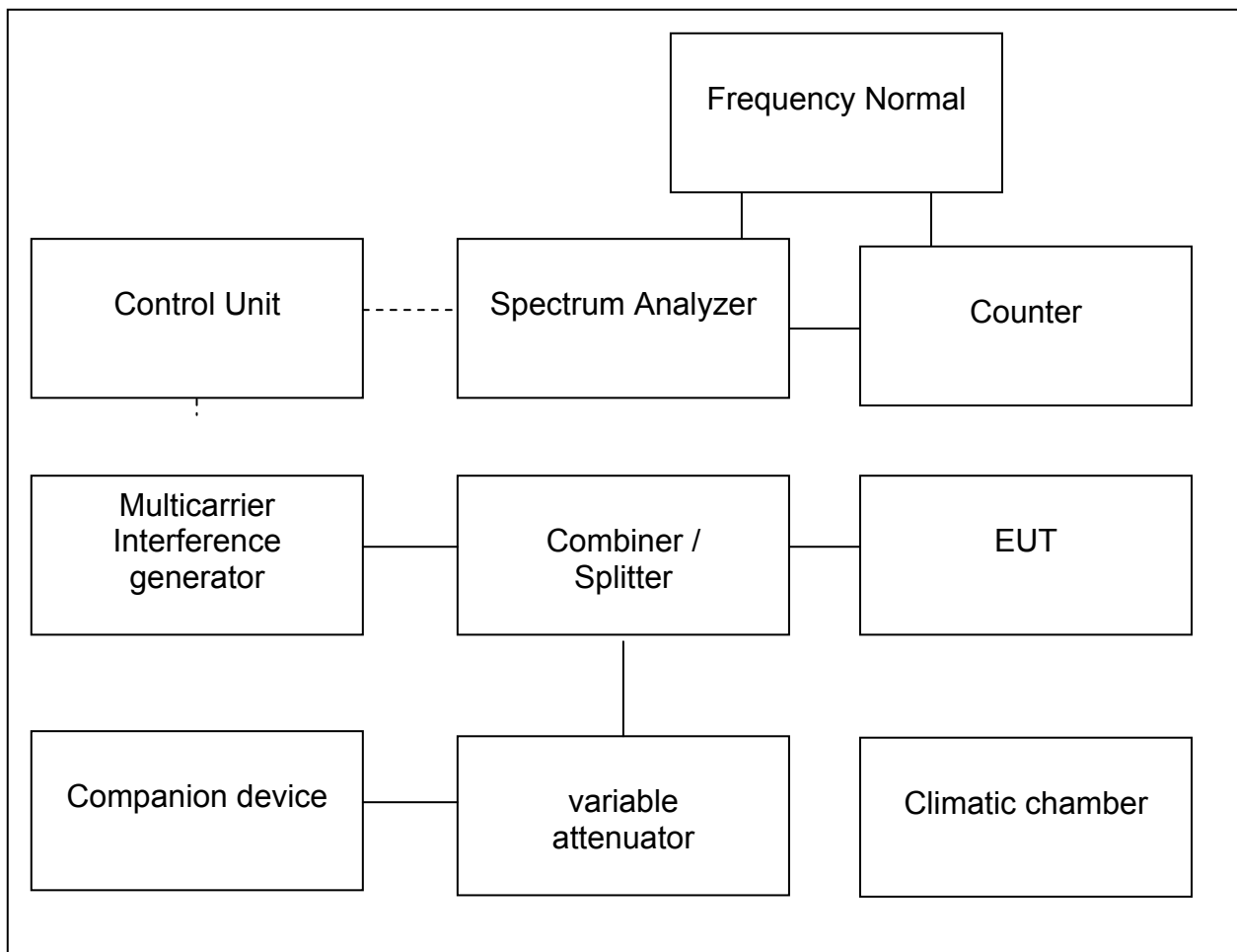

Test set-up 2 General equipment configuration for monitoring tests

Test equipment used: ETS 0406, ETS 0496, ETS 0495, ETS 0267, ETS 0539, ETS 0500, ETS 0501, ETS 0502, ETS 0497, ETS 0498, ETS 0224 C

Monitoring tests generally determine the lower and upper threshold of the EUT , and verify that if the EUT is operating in the “least-interfered channel” mode, it can properly select the channel with the lowest interference power, within a 6 dB resolution. The “preferred” end of the 1920-1930 MHz band denotes the end at which the search for channels with interference below the lower threshold shall begin. For devices with an emission bandwidth of less than 625 kHz, the search shall begin within 3 MHz , of the lower end of the band (i.e., 1920 MHz). For device with an emission bandwidth of greater than 625 kHz, the search shall begin within 3 MHz of the upper end of the band.

Calculation of monitoring threshold limits for isochronous devices:

Lower threshold:

$$T_L = 15 \log_{10}B - 184 + 30 - P \text{ (dBm)}$$

Upper threshold:

$$T_H = 15 \log_{10}B - 184 + 50 - P \text{ (dBm)}$$

B= emission bandwidth (Hz) }
 P = transmitted power (dBm) } measured values

calculated thresholds:

lower threshold [dBm]	--
upper threshold [dBm]	--

The upper threshold is applicable for systems which have defined a minimum of 40 duplex system access channels.

Measurement procedure:

For devices without LIC procedure:

For a not or defined interfered band the system will initiate a connection on channel with the lowest level.

After that interferer level on this channel will be increased by 1dB steps, until a new connection on an other channel will established. The related interferer level represents the measured lower threshold.

For devices supporting LIC (least interferer channel) procedure:

Except of two channels (f_1 ; f_2) all other channels are blocked by interferers at levels of 26 dB above the lower limit. Then interferers apply to f_1 and f_2 with dedicated levels related to calculated lower threshold according to Revision Draft ANSI 63.17 sub-clause 7.3.3, check the behavior and repeat each test case 5 times. If the behavior is correct all times, the test is passed.

Upper threshold (for > 40 channels):

An interferer level of about 16 dB above calculated upper threshold is applicable on all system carriers. The interference level is uniformly decreased on all carriers until the EUT starts to transmit. This level is upper threshold.

Results:

Least interfered channel	--
Lower threshold [dBm]	n.a.
Upper threshold [dBm]	--

Comment: No test required.

Limits:

Used results	Emission bandwidth [MHz]	1.4.
	Peak transmit power [dBm]	19.89
Limits	Lower threshold [dBm] + 6 dB margin	$\leq -78.6 \dots -72.6$
	Upper threshold [dBm] + 6 dB margin	$\leq -58.6 \dots -52.6$

3.1.13 Monitoring of intended transmit window and maximum reaction time, FCC 15.323 (c)(1); RSS-213 4.3.4 (b)(1)

Immediately prior to initiating transmission, devices must monitor the combined time and spectrum window in which they intend to transmit. For a period of at least 10 milliseconds for systems designed to use a 10 millisecond or shorter frame period or at least 20 milliseconds for systems designed to use a 20 millisecond frame period.

Monitoring of intended transmit window is tested according to Revision Draft ANSI 63.7 sub-clause 7.5 using test set-up No. 2.

These tests are related to isochronous reaction time and monitoring interval.

The reaction time is the duration of the RF power, during the monitoring interval, that shall be detected by the device to determine that the monitored time and spectrum window is occupied.

The objective of the test is to demonstrate that the device defers use of a region of spectrum when the interfering signals are of a time duration that exceeds the allowed limit.

If the sample fulfills the requirements of reaction time it shows that it has monitored the intended transmit window.

Test c:

With the channel interferer level at the calculated threshold limit, plus a 6 dB margin verify that the EUT does not establish a connection when the width of the interference pulse exceeds the largest of 50 μ s and $50 \sqrt{1.25/B}$ μ s.

B-Emission bandwidth of EUT in MHz

Test d:

With the channel interferer set to a level that is 6 dB above the calculated threshold limit, plus a 6 dB margin, verify that no connection occurs with a interference pulse width which exceeds the largest of 35 μ s and $35 \sqrt{1.25/B}$ μ s.

Results:

Pulse width	Connection	
	F _L	F _U
50 μ s or $50 \sqrt{1.25/B}$ μ s	no	no
35 μ s or $35 \sqrt{1.25/B}$ μ s	no	no

Verdict:

Pass	Fail
<input type="checkbox"/>	<input type="checkbox"/>

Comment: No test required.

Calculation of applied pulse width and maximum reaction time:
 For Emission bandwidth > 1,25 MHz the pulse width is always 35 µs and 50 µs

Used results	Emission bandwidth [MHz]	e.g. 1.434
Max. reaction time and Pulse width	$50 \sqrt{1.25/B} \mu\text{s}$.	46.68
	$35 \sqrt{1.25/B} \mu\text{s}$	32.67

3.1.14 Monitoring bandwidth, Monitoring reaction time, FCC 15.323 (c)(7); RSS-213, 4.3.4 (b)(7)

Monitoring bandwidth is measured according to Revision Draft ANSI 63.17 sub-clause 7.4.1. using test set-up No. 2.

Test procedure:

Center the interfering signal at a frequency above the center of the emission of the EUT, separated by 30% of the emission bandwidth of the EUT, at a level that is 10 dB + U_M above the appropriate threshold limit. The bandwidth of the interfering signal shall be equal to or greater than the minimum emission bandwidth allowed for the sub-band. It shall be verified that the EUT does not establish a connection. The procedure is repeated with the interference centered at a frequency below the center of the emission of the EUT, separated by 30% of the emission bandwidth of the EUT, at a level that is 10 dB + U_M above the appropriate threshold limit. It shall be verified that the EUT does not establish a connection.

Results:

Interferer level [dBm]		--
Test frequency	Interferer frequency	Connection
F_L	F_L - 30 % BW	--
	F_L + 30 % BW	--
F_U	F_U - 30% BW	---
	F_U + 30 % BW	--

Verdict:

Pass	Fail
<input type="checkbox"/>	<input type="checkbox"/>

Comment: No test required.

3.1.15 Random waiting interval, FCC 15.323 (c)(6); RSS-213, 4.3.4 (b)(6)

If the selected combined time and spectrum windows are unavailable, the device may either monitor and select different windows or seek to use the same window after waiting an amount of time, randomly chosen from a uniform random distribution between 10 and 150 milliseconds, commencing when the channel becomes available.

Random waiting interval is considered according ANSI 63.17 sub-clause 8.1.3.
This test applies to an EUT capable of transmitting control and signaling information on its own without companion device.

It is measured the time interval between the end of the EUT transmission and the beginning of transmission by the EUT in the same time and spectrum window..
Test set-up No. 1 is used.

Comment: This test is not applicable for this EUT.

Test procedure: ANSI 63.17 Sub-clause 8.1

3.1.16 Duration of Transmission, FCC 15.323 (c)(3); RSS-213 4.3.4 (b)(3)

If no signal above the threshold level is detected, transmission may commence and continue with the same emission bandwidth in the monitored time and spectrum windows without further monitoring. However, occupation of the same combined time and spectrum window by a device or group of cooperating devices continuously over a period of time longer than 8 hours is not permitted without repeating the access criteria.

Duration of Transmission (Maximum transmit period) is measured according to Revision Draft ANSI 63.17 sub-clause 8.2.2 using test set-up No. 1.

Comment: For DECT based technology the PP is the initiating device and determines duration of transmission. The fix part follows the portable part.

Result:

Maximum transmission time [min]	n.a.
---------------------------------	------

Limit:

Maximum transmission time [h]	< 8
-------------------------------	-----

Verdict:

Pass	Fail
<input type="checkbox"/>	<input type="checkbox"/>

Comment: No test required.

**3.1.17 Connection acknowledgements, Unacknowledged transmissions
FCC 15.323(c)(4);
RSS-213 4.3.4 (b)(4)**

Once access to specific combined time and spectrum windows is obtained an acknowledgement from a system participant must be received by the initiating transmitter within one second or transmission must cease. Periodic acknowledgements must be received at least every 30 seconds or transmission must cease. Channels used exclusively for control and signaling information may transmit continuously for 30 seconds without receiving an acknowledgement, at which time the access criteria must be repeated.

Connection acknowledgements are tested according to Revision Draft ANSI 63.17 sub-clause 8.2.1, Unacknowledged transmission following sub clause 8.1.1. Access criteria test interval and 8.1.2 Access criteria functional test. subclause 8.1.3 Access criteria functional test is not applicable because option FCC 15.323 (c)(6) /RSS-213 4.3.4 (b)(6) is not implemented.

Unacknowledged transmission:

Results:

Requirement	Time	Verdict
Access criteria test interval (8.1.1)	--	--
Access criteria functional test (8.1.2)	--	--

Limits:

Requirement	Value
Access criteria test interval (8.1.1)	≤ 30 s
Access criteria functional test (8.1.2)	mandatory

Connection acknowledgement

Requirement	Time	Verdict
Connection acknowledgement [8.2.1 (a)(b)] PP only	--	n.a.
Termination of transmission [8.2.1 (c)]	--	--

Limits:

Requirement	Value
Connection acknowledgement [8.2.1 (a)(b)] PP only	≤ 1 s
Termination of transmission [8.2.1 (c)]	≤ 30 s

Comment: No test required.

**3.1.18 Selected channel confirmation, segment occupancy, FCC 15.323 (c)(5);
RSS-213 4.3.4 (b)(5)**

If a minimum of 40 duplex system access channels are defined, the system must have monitored all access channels defined for its system within the last 10 seconds and must verify, within the 20 milliseconds (40 milliseconds for devices designed to use a 20 milliseconds frame period) immediately preceding actual channel access that the detected power of the selected time and spectrum windows is no higher than the previously detected value.

The power measurement resolution for this comparison must be accurate within 6 dB.

No device or group of co-operating devices located within 1 meter of each other shall during any frame period occupy more than 6 MHz of aggregate bandwidth, or alternatively, more than one third of the time and spectrum windows defined by the system.

Selected channel confirmation:

This test is done according to Revision Draft ANSI 63.17 sub-clause 7.3.4 using test set-up No. 2.

Results:

Test	Transmit on f_1	Transmit on f_2	Verdict
--	--	--	--

Power accuracy

The power measurement resolution for the previous comparisons must be accurate to within 6 dB.

This requirement was proved automatically by testing of monitoring thresholds according to FCC 15.323 (c)(2); RSS-213 4.3.4 (b)(2), see 2.4.12.

Segment occupancy

Document	available	sufficient
Manufacturers declaration	<input checked="" type="checkbox"/>	<input checked="" type="checkbox"/>
Technical description	<input type="checkbox"/>	<input type="checkbox"/>

Comment: No test required.

3.1.19 Monitoring antenna, FCC 15.323 (c)(8); RSS-213 4.3.4 (b)(8)

The monitoring system shall use the same antenna used for transmission, or an antenna that yields equivalent reception at that location.

The monitoring system shall use the same antenna used for transmission or an antenna that yields equivalent reception at that location.

System uses same antenna(s)	<input checked="" type="checkbox"/>
System uses different antenna(s)	<input type="checkbox"/>

If the monitoring antenna is different from the transmitting antenna, it shall be verified that the monitoring antenna provides coverage equivalent to that of the transmitting antenna.

The related tests are to perform according to Revision Draft ANSI 63.17 sub-clause 4.5 using test set-up No. 3.

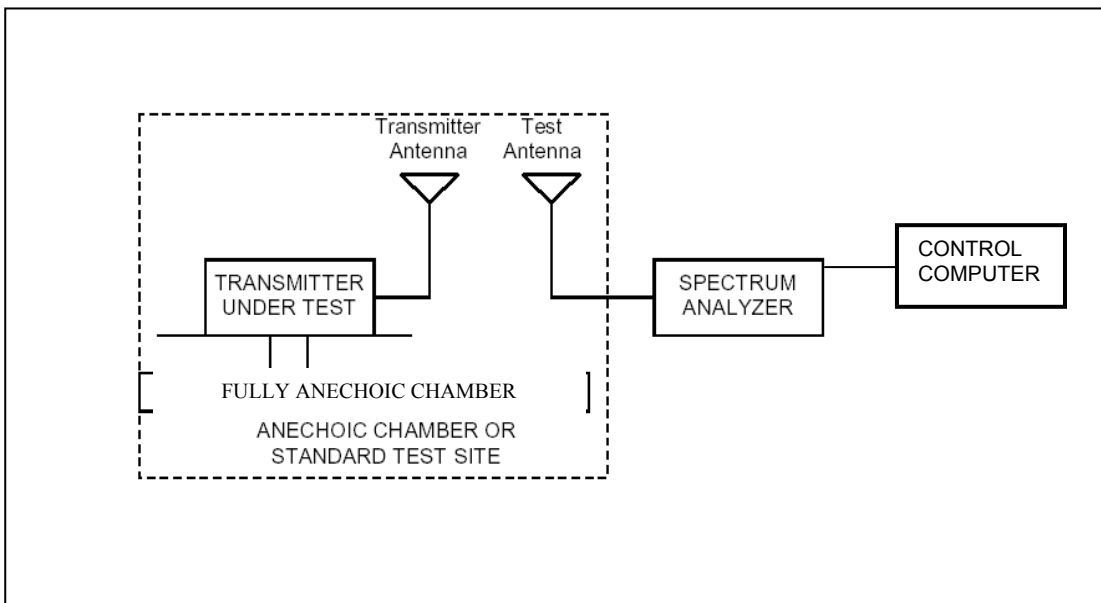

Test set-up 3 Equipment configuration for radiated tests

Test equipment used: ETS 0012, ETS 0013, ETS 0014, ETS 0031, ETS 0253, ETS 0310

3.1.20 Duplex connections, FCC 15.323 (c)(10); RSS-213 4.3.4 (b)(10)

An initiating device may attempt to establish a duplex connection by monitoring both its intended transmit and receive time spectrum windows. If both the intended transmit and receive time and spectrum window meet the access criteria, then the initiating device can initiate a transmission in the intended transmit time and spectrum window. If the power detected by the responding device can be decoded as a duplex connection signal from the initiating device, then the responding device may immediately begin transmitting on the receive time and spectrum window monitored by the initiating device.

This test verifies that the two devices communicating over a duplex connection comply with the access criteria. The Initiating device is the EUT, the responding device is the companion device tested in conjunction with the EUT.

The EUT is a responding device Therefore these tests are not applicable	<input type="checkbox"/>
The EUT do not implement upper threshold. ANSI 63.17 8.3.1 is applicable	<input type="checkbox"/>
The EUT implements upper threshold. ANSI 63.17 8.3.2 is applicable	<input type="checkbox"/>

Tests according to subclause 8.3.1 “Validation of dual access criteria check for EUTs which do not implement the upper threshold”:

Test b)

The test proves the basic conditions for the following tests. The out-of-operating-region interference is used to confine the EUT to the band.

Test c) and d)

These tests proves whether a connection can be established with interferences levels of $T_L + U_M$ on all if its receive time/spectrum windows except one which is interference free.

Apply interference at $T_L + U_M$ on all transmit time/spectrum windows of the EUT.

If a connection is established the test fails.

Test e) and f)

These tests proves whether a connection can be established with interferences levels of $T_L + U_M$ on all if its transmit time/spectrum windows except one which is interference free.

Apply interference at $T_L + U_M$ on all receive time/spectrum windows of the EUT.

If a connection is established the test fails.

Tests according to subclause 8.3.2 “Validation of dual access criteria check for EUTs which implement the upper threshold”:

Test b)

The test proves the basic conditions for the following tests. The out-of-operating-region interference is used to confine the EUT to the band.

Test c) and d)

Apply interferences of $T_L + U_M$ to the EUT on the EUTs transmit time/ spectrum windows except for one which is free of interferences. Apply interferences of $T_L + U_M + 7$ dB to the receive time/spectrum windows except for one which is free of interferences. The interference-free receive time/spectrum window must not be the duplex mate of the interference-free transmit time/spectrum window. The connection should be made on the interference-free time/spectrum window and its duplex mate.

Test e) and f)

Apply interferences of $T_L + U_M$ to the EUT on the EUTs receive time/spectrum windows except one which is free of interferences. Apply interferences of $T_L + U_M + 7$ dB to the transmit time/spectrum windows except one which is free of interferences. The interference-free time/spectrum windows should not constitute a duplex pair.

The connection should be made on the interference free transmit time/spectrum window and its duplex mate.

Test g)

Raise the interferences to the EUT on all of the EUTs transmit and receive time/spectrum windows to $T_U + U_M$ except for a single transmit time/spectrum window and a single receive time/spectrum window which shall have low interference levels.

These low-interference level time/spectrum windows shall not constitute a duplex pair. If the EUT transmits or a connection is established, the test is failed.

Test		applicable	Connection	No connection	verdict
8.3.1	c) and d)	<input type="checkbox"/>	<input type="checkbox"/>	<input type="checkbox"/>	n.a.
	e) and f)	<input type="checkbox"/>	<input type="checkbox"/>	<input type="checkbox"/>	n.a.
8.3.2	c) and d)	<input type="checkbox"/>	<input type="checkbox"/>	<input type="checkbox"/>	n.a.
	e) and f)	<input type="checkbox"/>	<input type="checkbox"/>	<input type="checkbox"/>	n.a.
	g)	<input type="checkbox"/>	<input type="checkbox"/>	<input type="checkbox"/>	n.a.

Comment: For DECT based technology the PP is the initiating device and determines duplex connections.

Comment: No applicable

3.1.21 Alternative monitoring interval for co-located devices, FCC 15.323 (c)(11); RSS–213 4.3.4 (b)(11)

An initiating device that is prevented from monitoring during its intended transmit window due to monitoring system blocking from the transmissions of a co-located (within one meter) transmitter of the same system, may monitor the portions of the time and spectrum windows in which they intend to receive over a period of at least 10 milliseconds. The monitored time and spectrum window must total at least 50 percent of the 10 millisecond frame interval and the monitored spectrum must be within 1.25 MHz of the center frequency of channel(s) already occupied by that device or co-located co-operating device. If the access criteria is met for the intended receive time and spectrum window under the above conditions, then transmission in the intended transmit window by the initiating device may commence.

Alternative monitoring interval for co-located devices may be tested according Revision Draft ANSI 63.17 sub-clause 8.4 using test set-up No. 2.

Results.

The manufacturer declares that this provision is not utilized by the EUT.

3.1.22 Fair access to spectrum related to (c)(10) and (c)(11), FCC 15.323 (c)(12); RSS–213 4.3.4 (b)(12)

The provisions of FCC 15.323 (c)(10) or (c)(11) and RSS–213 4.3.4 (b)(10) or (11) shall not be used to extend the range of spectrum occupied over space or time for the purpose of denying fair access to spectrum for other devices.

The manufacturer declares that is device does not work in a mode which denies fair access to spectrum for other participants.

3.1.23 Radiated spurious emissions, generally requirements

Reference

FCC	CFR part 15.247(d), 15.205. 15.209, 15.35
IC	RSS-210 A8.5, RSS-210 2.7

Method of measurement

Spurious emission was measured with modulation (declared by manufacturer).

According to 47 CFR 15, Part 15.247 (d): In any 100 kHz bandwidth outside the frequency band in which the spread spectrum or digitally modulated intentional radiator is operating, the radio frequency power that is produced by the intentional radiator shall be at least 20 dB below that in the 100 kHz bandwidth within the band that contains the highest level of the desired power, based on either an RF conducted or a radiated measurement, provided the transmitter demonstrates compliance with the peak conducted power limits.

If the transmitter complies with the conducted power limits based on the use of RMS averaging over a time interval, as permitted under paragraph (b)(3) of this section, the attenuation required under this paragraph shall be 30 dB instead of 20 dB. Attenuation below the general limits specified in Section 15.209(a) is not required.

In addition, radiated emissions which fall in the restricted bands, as defined in Section 15.205(a), must also comply with the radiated emission limits specified in Section 15.209(a) (see Section 15.205(c)).

Calculation of Limit:

All results are updated by an automatic measuring system in accordance to point 2.3

Limit = max. reading (because peak detector is used)

Limit = Max. reading - 20 dB (because average detector is used)

Limits for restricted bands

FCC & IC	20 dB below peak output power, emissions which fall in the restricted bands (15.205(a)) / (RSS-210 2.7) must comply the following limits: Frequencies below 1GHz:		
	Frequency of emission	Field strength	Field strength
	[MHz]	[$\mu\text{V} / \text{m}$]	[dB $\mu\text{V} / \text{m}$]
	30 - 88	100	40.0
	88 - 216	150	43.5
	216 - 960	200	46.0
	Above 960	500	54.0
For frequencies above 1 GHz (Avg measurements): 54.0 dB $\mu\text{V} / \text{m}$ For frequencies above 1 GHz (Pk measurements): Limit + 20 dB = 54.0 dB $\mu\text{V} / \text{m}$ + 20 dB = 74 dB $\mu\text{V} / \text{m}$			

Calculation of test results:

Such factors like antenna correction, cable loss, external attenuation etc. are already included in the provided measurement results.

The peak and average spurious emission plots was measured with the average limits. In the Table being listed the critical peak and average value an exhibit the compliance with the above calculated Limits.

If in the column's correction factor states a value then the max. Field strength in the same row is corrected by a value gained from the "Marker-Delta-Method" or the „Duty-Cycle Correction Factor“.

15.35 (c) Duty cycle correction average value

When the radiated emission limits are expressed in terms of the average value of the emission, and pulsed operation is employed, the measurement field strength shall be determined by averaging over one complete pulse train, including blanking intervals, as long as the pulse train does not exceed 0.1 seconds.

Duty cycle correction = $20 \log(\text{dwell time} / 100 \text{ ms or less})$

DA 00-705 Duty cycle correction peak value

The analyzer setting was as following:

Frequency range	RES bandwidth		Video bandwidth	
	Pk	Avg	Pk	Avg
f < 1GHz	100 kHz	100 kHz	10 Hz	10 Hz
f > 1GHz	1 MHz	1 MHz	10 Hz	10 Hz

Set the VBW to 10 Hz, while maintaining all of the other instrument settings. This peak level, once corrected, must comply with the limit specified in Section 15.209. If the dwell time per channel of the hopping signal is less than 100 ms, then the reading obtained with the 10 Hz VBW may be further adjusted by a "duty cycle correction factor", derived from $20 \log(\text{dwell time} / 100 \text{ ms})$, in an effort to demonstrate compliance with the 15.209 limit. Submit this data.

If the intentional radiator operates below 10 GHz: to the tenth harmonic of the highest fundamental frequency or to 40 GHz, whichever is lower.

Test results

Summary table with radiated data of the test plots

Freq.	Used Ch.	Frequency Marker [GHz]	Polarization	Δ corrections dB	Max. Field Strength [dB μ V/m]	Compliance Limit [dB μ V/m]	Detector	BW [kHz]	Margin [dB]
3	L/H	1.930	V		-43.67	-39.5	P	10	-4.17
3	L/H	1.930	H		-47.79	-39.5	P	10	-8.29

Freq. - Frequency Range:

1:	30	–	200 MHz
2:	200	–	1000 MHz
3:	1	–	4 GHz
4:	4	–	8 GHz
5:	8	–	12 GHz
6:	12	–	17 GHz
7:	17	–	26,5 GHz

Comment: For measurements diagrams see Annex D.

**Emissions inside and outside the sub-bands, FCC 15.323 (d);
RSS-213 6.7**

Emissions outside the sub-bands shall be attenuated below a reference power of 112 milliwatts as follows: 30 dB between the sub-band and 1.25 MHz above or below the sub-band, (-9.5 dBm); 50 dB between 1.25 and 2.5 MHz above or below the sub-band, (-29.5 dBm); and 60 dB at 2.5 MHz or greater above or below the sub-band, (-39.5 dBm)

Emissions inside the sub-band must comply with the following emission mask: In the bands between 1B and 2B (“B” is defined as the emission bandwidth of the device in hertz) measured from the center of the emission bandwidth the total power emitted by the device shall be at least 50 dB below the transmit power permitted for that radiator; in the bands between 3B and the sub-band edge the total power emitted by an intentional radiator in the measurement bandwidth shall be at least 60 dB below the transmit power permitted for that radiator.

Compliance with the emission limits is based on the use of measurement instrumentation employing peak detector function with an instrument resolution bandwidth approximately equal to 1.0 percent of the emission bandwidth of the device under measurement.

Emission inside and outside the sub-band are tested according to ANSI 63.17 sub-clauses 6.1.6.1 and 6.1.6.2.

Determination of measurement bandwidth:

$$BT_T = \text{approx. } 1\% \text{ of } B$$

Used results	Emission bandwidth [MHz]	1.49
Calculated value	Resolution bandwidth [kHz]	14.9
Determined value	Resolution bandwidth [kHz]	10

Emissions inside the sub-band

Testing of emissions inside the sub-band are performed using test set-up No.1.
The applied emission mask limit was created using the current emission bandwidth.

For measurements diagrams see Annex K.

Emissions outside the sub-band

Out of sub band emissions are tested as radiated measurement bandwidth of about 1% of emission bandwidth near the band edges and at critical frequencies where the measurement values come near the limits. For practical reasons other frequencies the more stringent bandwidth of 100 kHz is used.
As test environment serves a fully anechoic chamber providing a free space environment (test set-up No. 3)

All results will be updated by an automatic measuring system in accordance with point 2.3.

Calculation of test results:

Such factors like antenna correction, cable loss, external attenuation etc. are already included in the provided measurement results. This is done by using validated test software and calibrated test system according the accreditation requirements.

The significant peak and average values are listed in the tables below showing the compliance with the above calculated limits. For frequency ranges with measurement value far below the limits no measurement diagrams are shown.

Summary table with radiated data of the test plots

Freq.	Used Ch.	Frequency Marker [GHz]	Polarization	Δ corrections dB	Max. Power level [dBm]	Compliance Limit [dBm]	Detector	BW [kHz]	Margin [dB]
--	--	--	--	--	--	--	--	--	--
--	--	--	--	--	--	--	--	--	--

Freq. – Frequency Range:

- 1: 30 – 200 MHz
- 2: 200 – 1000 MHz
- 3: 1 – 4 GHz
- 4: 4 – 8 GHz
- 5: 8 – 12 GHz
- 6: 12 – 17 GHz
- 7: 17 – 26.5 GHz

For measurements diagrams see Annex D.

Limits:

For spectrum mask and limit lines see diagrams.

Verdict:

Pass	Fail
<input checked="" type="checkbox"/>	<input type="checkbox"/>

3.1.24 Frame period, FCC 15.323 (e); RSS-213 4.3.4 (c)

The frame period (a set of consecutive time slots in which the position of each time slot can be identified by reference to a synchronizing source) of an intentional radiator operating in these subbands shall be 20 milliseconds/X where x is a positive whole number. Each device that implements time division for the purposes of maintaining a duplex connection on a given frequency carrier shall maintain a frame repetition rate with a frequency stability of at least 50 parts per millions (ppm). Each devices which further divides access in time in order to support multiple communication links on a given frequency carrier shall maintain a frame repetition rate with a frequency stability of at least 10 ppm. The jitter (time-related, abrupt, spurious variations in the duration of the frame interval) introduced at the two ends of such a communication link shall not exceed 25 microseconds for any two consecutive transmissions.

Transmissions shall be continuous in every time and spectrum window during the frame period defined for the device.

Frame repetition stability is tested according to Revision Draft ANSI 63.17 sub-clause 6.2.2. Frame period and jitter are tested following sub-clause 6.2.3. For all measurements test set-up No.1 is used.

Frame repetition stability:

The spectrum analyzer is used as an envelope detector and provides gating signals to a frequency counter. The obtained frequency values are computed to get mean value, deviation and frame repetition stability. Frame repetition stability is three times of the standard deviation SD.

Results:

Frequency (MHz)	Standard Deviation (Hz)	Mean(Hz)	3 x SD (ppm)
1924.992	0.12E-04	100.000545	0.371238

Limits:

Time division mode	Frame repetition stability	applicable
TDA	50 ppm	<input type="checkbox"/>
TDMA	10 ppm	<input checked="" type="checkbox"/>

Verdict:

Pass	Fail
<input checked="" type="checkbox"/>	<input type="checkbox"/>

Frame period and jitter:

Frame period and jitter test the spectrum and modulation is used to obtain the time duration between rising edges. These measurement value are used to compute the difference between any two consecutive frame periods (jitter).

The measured mean time is the frame period.

Results:

Frequency (MHz)	Mean (ms)	Deviation (Hz)	Peak to Peak (µs)
1924.992	9.999568	1.0E-05	0.047497

For examples of measurements sheets see Annex E.

Limits:

Frame period [ms]	20 or 10/x
Max. jitter [µs]	25
3 times the standard deviation SD [µs] value of jitter ²⁾	12.5

²⁾ This item is not required by FCC 15.323(e).

Verdict:

Pass	Fail
<input checked="" type="checkbox"/>	<input type="checkbox"/>

3.1.25 Frequency stability, FCC 15.323 (f); RSS – 213 6.2

The frequency stability of the carrier frequency of the intentional radiator shall be maintained within ± 10 ppm over 1 hour or the interval between channel access monitoring, whichever is shorter. The frequency stability shall be maintained over a temperature variation of -20° to +50 ° degrees C at normal supply voltage, and over a variation in the primary supply voltage of 85 percent to 115 percent of the rated supply voltage at a temperature of 20°C. For equipment that is capable only of operating from a battery, the frequency stability tests shall be performed using a new battery without any further requirements to vary supply voltage.

Frequency stability is measured by spectrum analyzer in modulation mode according to Revision Draft ANSI 63.17 sub-clause 6.2.1.

The procedure is carried out with conditions shown in result table below, where the first row shows the carrier frequency stability over time.

Results:

Temp °C	Supply Voltage	Frequency of carrier (MHz)	Stability over time (ppm)		Mean (MHz)	Deviation ppm
			f _{max}	f _{min}		
20	Vnom	1924.963968	7.18	8.14	1924.965055	-0.56
20	Vmin	--	--	--	--	--
20	Vmax	--	--	--	--	--
-10	Vnom	--	--	--	--	--
55	Vnom	--	--	--	--	--

Limit : 10 ppm

$$Deviation\ ppm = \frac{FR - FM}{FR} * 10^6,9$$

FR = Reference frequency of carrier at 20°C and V_{nom}

FM = Measured frequency of carrier

Limit:

Temperature [°C]	Supply voltage	Frequency deviation [ppm]
20	85-115% or new batteries	Reference
-20	Normal	10
+50	Normal	10
Others ¹⁾ -10	Normal	10
Others ¹⁾ +55	Normal	10

¹⁾ declared by manufacturer

Verdict:

Pass	Fail
<input checked="" type="checkbox"/>	<input type="checkbox"/>

For measurements diagrams see Annex F.

3.1.26 Receiver spurious emissions, RSS-213 6.8

Receiver spurious emissions shall comply with the limits specified in RSS-Gen.

For radiated measurements the resolution bandwidth of the spectrum analyzer shall be 100 kHz for spurious emissions below 1 GHz and 1 MHz above 1 GHz. For emissions below 1 GHz a CISPR quasi peak demodulator is used. Above 1 GHz an average detector is used.

The receiver operating frequency shall be putted to the middle of the band for this test.

Results:

Summary table

Freq.	Frequency Marker [MHz]	Polarization	Δ corrections dB	Worst case emission level [μ V/m]	Compliance Limit [μ V/m]	Margin [μ V/m]
1	62,300			24,18	100	<u>-75,82</u>
	198,489			22,83	150	<u>-127,17</u>
2	964,444			11,55	500	<u>-488,45</u>
	975,111			11,71	500	<u>-488,29</u>
3	3770,000			142,40	500	<u>-357,60</u>
	3990,000			131,22	500	<u>-368,78</u>
4	7591,000			142,72	500	<u>-357,28</u>
	7960,000			130,02	500	<u>-369,98</u>

Freq. – Frequency Range:

- 1: 30 – 200 MHz
- 2: 200 – 1000 MHz
- 3: 1 – 4 GHz
- 4: 4 – 8 GHz

Limit:

Spurious Frequency (MHz)	Field Strength (microvolt/m at 3 metres)	dB μ V/m
30 – 88	100	40
88 – 216	150	43.5
216 – 960	200	46
Above 960	500	54

Verdict:

Pass	Fail
<input checked="" type="checkbox"/>	<input type="checkbox"/>

For measurements diagrams see Annex G.

Annex

A	Pictures	9 pages
B	Emission bandwidth	6 pages
C	Peak Transmit Power	2 pages
D	Spurious emissions; Emissions inside and outside the sub-band	28 pages
E	Frame period	2 pages
F	Frequency stability	1 pages
G	Receiver spurious emissions	8 pages

Annex B

Emission bandwidth

FCC Part 15.303(b) Emission bandwidth

Testprocedure ANSI 63.17-2006 6.1.3UPCS

EUT	DECT RFP
Model	RFP5 1G9
Applicant	Polycom Denmark ApS
Temperature	23°C
Test Site / Operator	Eurofins Product Service GmbH
Test Specification	6.1.3 Emission bandwidth

Measured Bandwidth Emission Bandwidth = 1.4MHz
 Max. Permitted Power Limit = 2.5 MHz

Test result Verdict = PASS



Emission Bandwidth

*RBW 10 kHz Delta 2 [T1]
 *VBW 30 kHz 0.81 dB

Ref 25 dBm

*Att 40 dB

SWT 40 ms

1.400000000 MHz

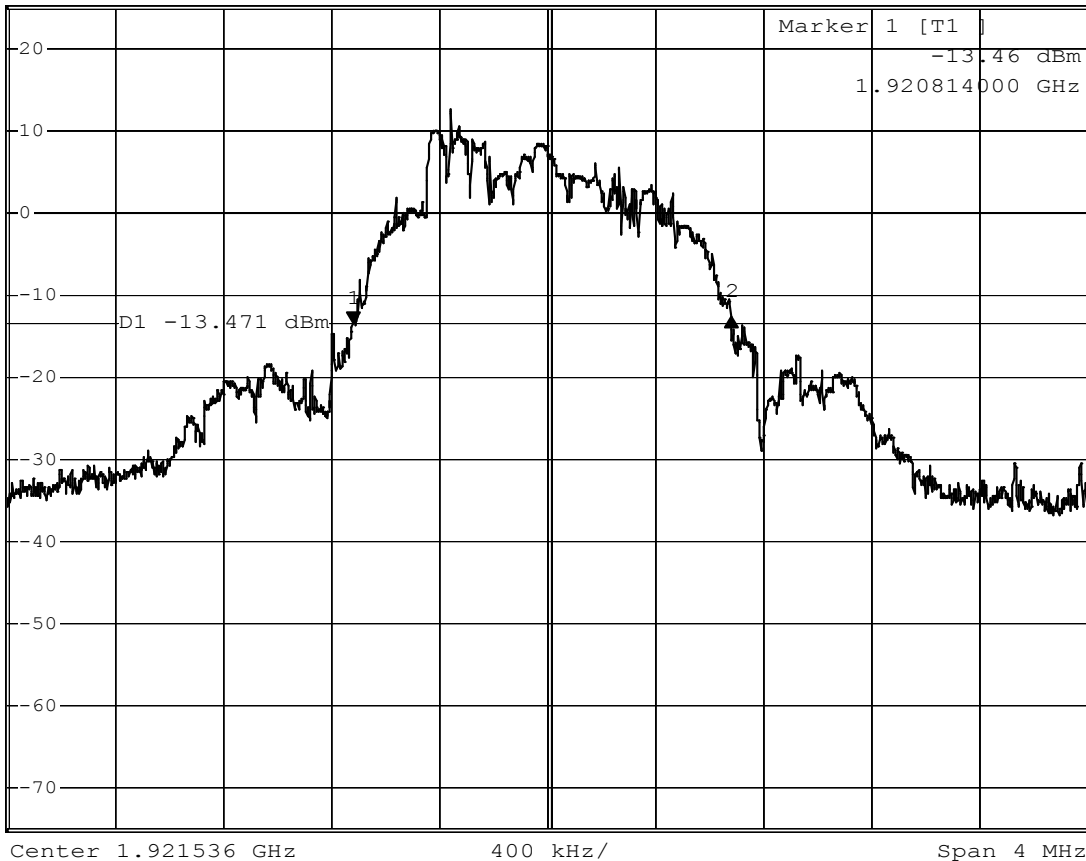

Comment: Ansi C63.17-2006 6.1.3

Date: 11.DEC.2008 13:47:09

Measurement diagram

Eurofins Product Service GmbH
 Storkower Str. 38c, D-15526 Reichenwalde, Germany

**Additional values as required for the detailed threshold monitoring bandwidth test
ANSI C63.17-1988 7.4.2**

-6 dB points

Lower frequency : 1921.096MHz
Higher frequency : 1921.554MHz

-12 dB points

Lower frequency : 1920.974MHz
Higher frequency : 1922.002MHz

FCC Part 15.303(b) Emission bandwidth

Testprocedure ANSI 63.17-2006 6.1.3UPCS

EUT	DECT RFP
Model	RFP5 1G9
Applicant	Polycom Denmark ApS
Temperature	23°C
Test Site / Operator	Eurofins Product Service GmbH
Test Specification	6.1.3 Emission bandwidth

Measured Bandwidth Emission Bandwidth = 1.38MHz
 Max. Permitted Power Limit = 2.5 MHz

Test result Verdict = PASS



Emission Bandwidth

*RBW 10 kHz Delta 2 [T1]

*VBW 30 kHz 1.62 dB

Ref 25 dBm

*Att 40 dB

SWT 40 ms

1.380000000 MHz

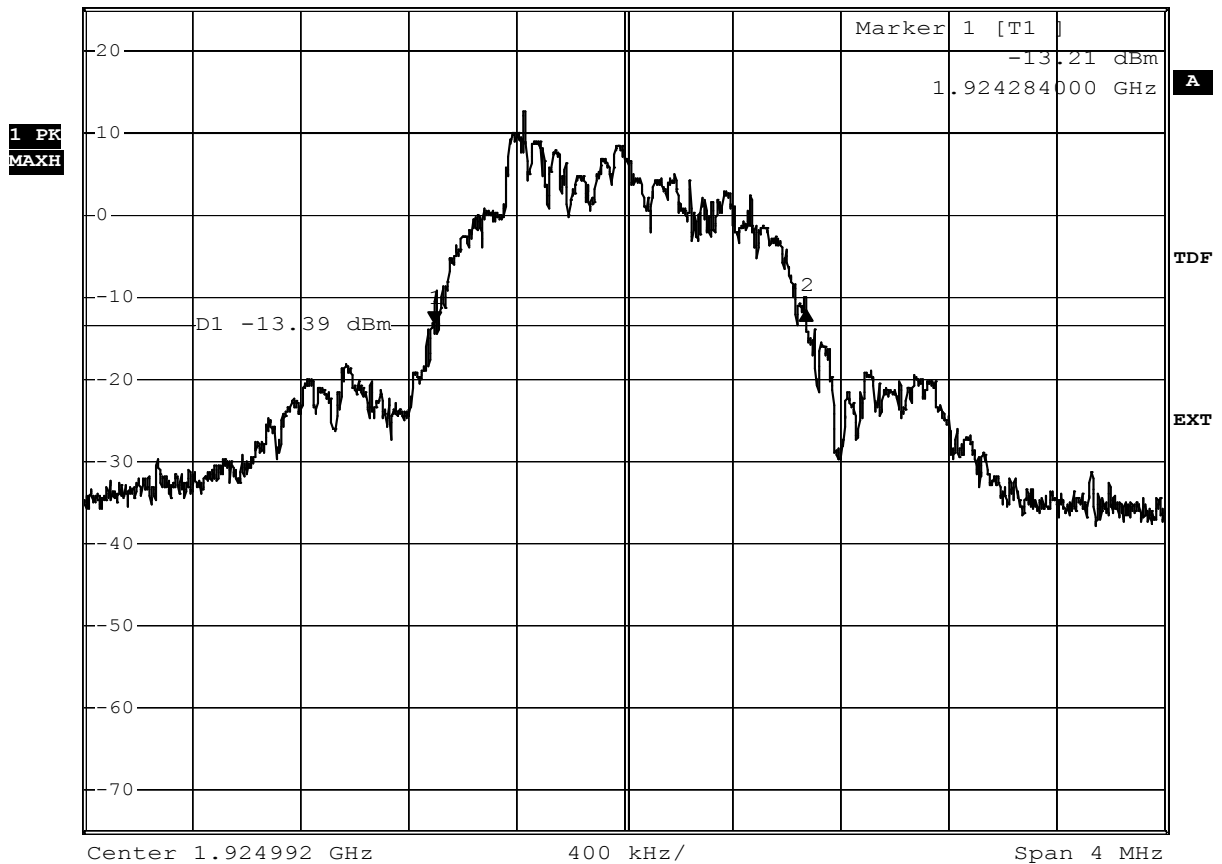

Comment: Ansi C63.17-2006 6.1.3
 Date: 11.DEC.2008 13:38:21

Measurement diagram

Eurofins Product Service GmbH
 Storkower Str. 38c, D-15526 Reichenwalde, Germany

**Additional values as required for the detailed threshold monitoring bandwidth test
ANSI C63.17-1988 7.4.2**

-6 dB points

Lower frequency : 1924.564MHz
Higher frequency : 1924.998MHz

-12 dB points

Lower frequency : 1924.472MHz
Higher frequency : 1925.4MHz

FCC Part 15.303(b) Emission bandwidth

Testprocedure ANSI 63.17-2006 6.1.3UPCS

EUT	DECT RFP
Model	RFP5 1G9
Applicant	Polycom Denmark ApS
Temperature	23°C
Test Site / Operator	Eurofins Product Service GmbH
Test Specification	6.1.3 Emission bandwidth

Measured Bandwidth Emission Bandwidth = 1.44MHz
 Max. Permitted Power Limit = 2.5 MHz

Test result Verdict = PASS



Emission Bandwidth

*RBW 10 kHz Delta 2 [T1]

*VBW 30 kHz 0.25 dB

Ref 25 dBm

*Att 40 dB

SWT 40 ms

1.43800000 MHz

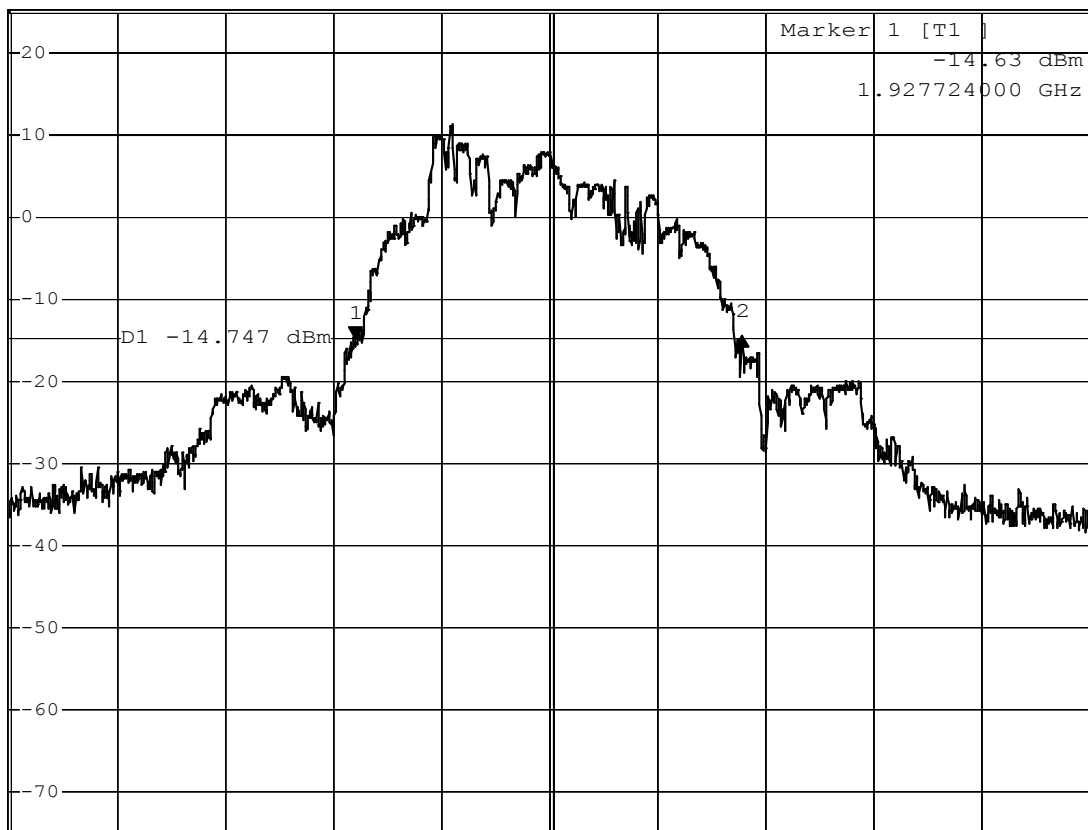

Center 1.928448 GHz

400 kHz/

Span 4 MHz

Comment: Ansi C63.17-2006 6.1.3
 Date: 11.DEC.2008 14:20:59

Measurement diagram

Eurofins Product Service GmbH
 Storkower Str. 38c, D-15526 Reichenwalde, Germany

**Additional values as required for the detailed threshold monitoring bandwidth test
ANSI C63.17-1988 7.4.2**

-6 dB points

Lower frequency : 1928.006MHz
Higher frequency : 1928.482MHz

-12 dB points

Lower frequency : 1927.906MHz
Higher frequency : 1928.918MHz

Annex C

Peak Transmit Power

FCC Part 15.319(c) Peak Transmit Power limit

Testprocedure ANSI 63.17-2006 6.1.2 UPCS

EUT	DECT RFP
Model	RFP5 1G9
Applicant	Polycom Denmark ApS
Temperature	23°C
Test Site / Operator	Eurofins Product Service GmbH
Test Specification	6.1.2 Peak transmit power
Supply	
Measured Bandwidth	1.4MHz
Max. Permitted Power	20,73 dBm
Measured Power	19,89 dBm
Test result	Verdict = PASS



Peak transmit power

RBW 3 MHz Marker 1 [T1]

*VBW 10 MHz -30.47 dBm

Ref 30 dBm

*Att 40 dB

SWT 200 µs

150.000000 µs

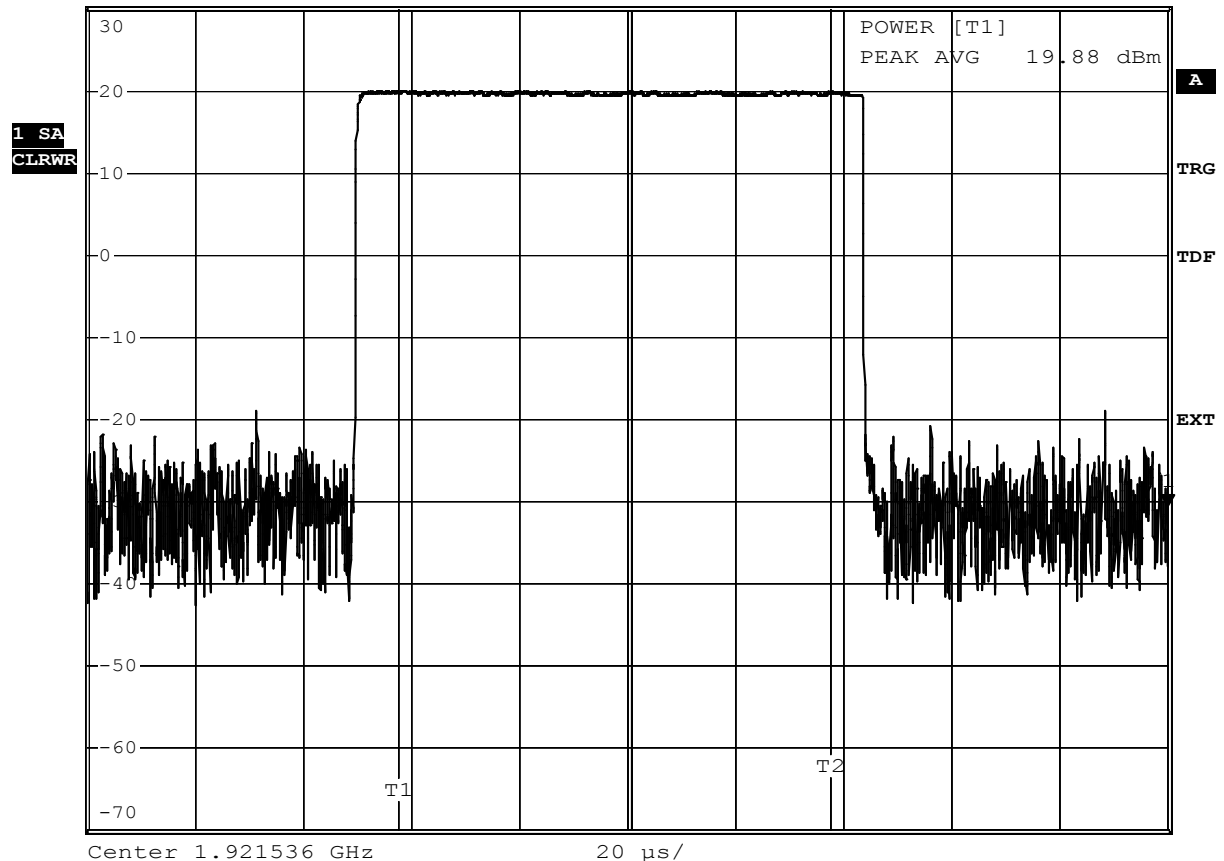

Comment: Ansi C63.17-2006 6.1.2

Date: 11.DEC.2008 14:04:09

Measurement diagram

 Eurofins Product Service GmbH
 Storkower Str. 38c, D-15526 Reichenwalde, Germany

FCC Part 15.319(c) Peak Transmit Power limit

Testprocedure ANSI 63.17-2006 6.1.2 UPCS

EUT	DECT RFP
Model	RFP5 1G9
Applicant	Polycom Denmark ApS
Temperature	23°C
Test Site / Operator	Eurofins Product Service GmbH
Test Specification	6.1.2 Peak transmit power
Supply	
Measured Bandwidth	1.438MHz
Max. Permitted Power	20,78 dBm
Measured Power	19,76 dBm
Test result	Verdict = PASS



Peak transmit power

RBW 3 MHz Marker 1 [T1]

*VBW 10 MHz 19.40 dBm

Ref 30 dBm

*Att 40 dB

SWT 200 µs

85.250000 µs

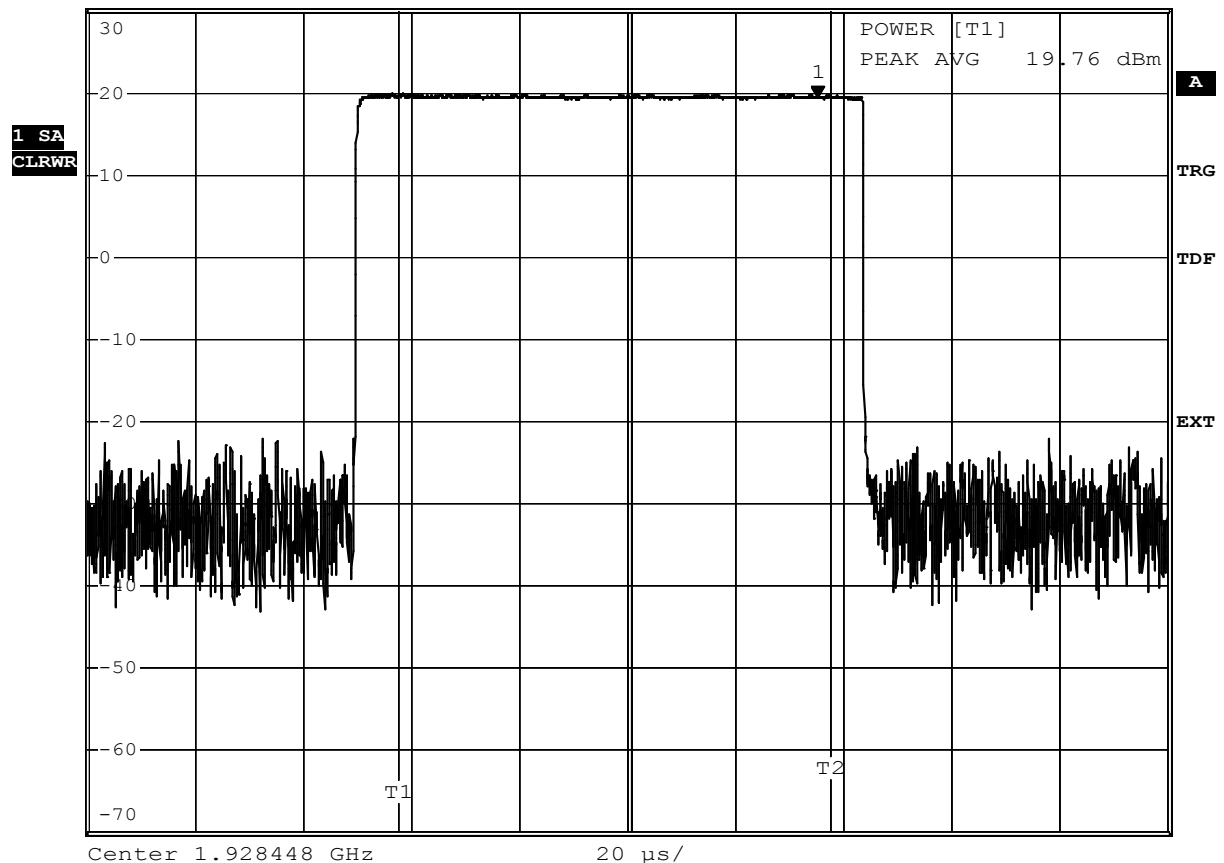

Comment: Ansi C63.17-2006 6.1.2
Date: 11.DEC.2008 14:24:18

Measurement diagram

Eurofins Product Service GmbH
Storkower Str. 38c, D-15526 Reichenwalde, Germany

Annex D

Emission inside and outside the sub-band; Spurious Emission

FCC Part 15.323(d.2) In-band unwanted emission

Testprocedure ANSI 63.17-2006 6.1.6.1 UPCS

EUT	DECT RFP
Model	RFP5 1G9
Applicant	Polycom Denmark ApS
Temperature	23°C
Test Site / Operator	Eurofins Product Service GmbH
Test Specification	6.1.6.1 In-band unwanted emission

1.4MHz



In-band unwanted emis

*RBW 10 kHz

*VBW 30 kHz

Ref 10 dBm

*Att 20 dB

*SWT 23 s

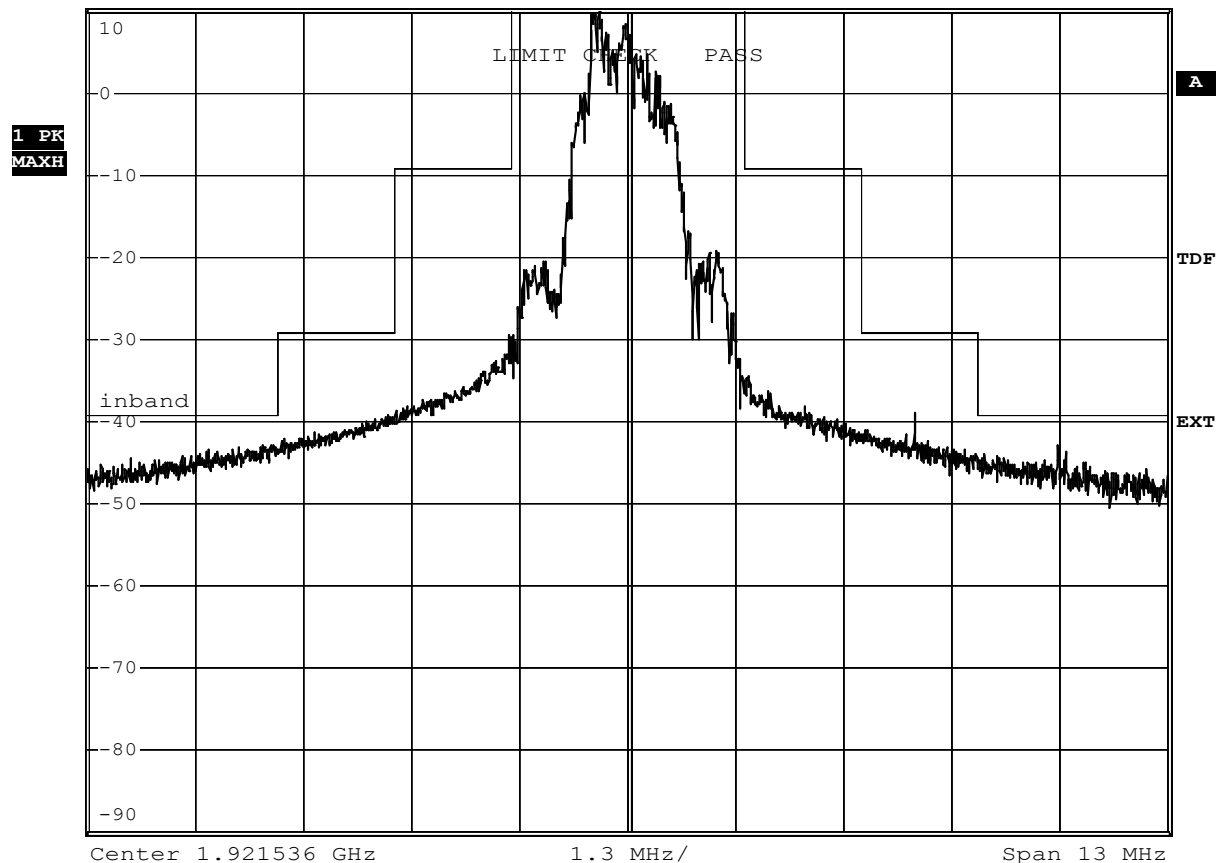

Comment: Ansi C63.17-2006 6.1.6.1

Date: 11.DEC.2008 14:12:24

Measurement diagram

Eurofins Product Service GmbH
Storkower Str. 38c, D-15526 Reichenwalde, Germany

FCC Part 15.323(d.2) In-band unwanted emission

Testprocedure ANSI 63.17-2006 6.1.6.1 UPCS

EUT	DECT RFP
Model	RFP5 1G9
Applicant	Polycom Denmark ApS
Temperature	23°C
Test Site / Operator	Eurofins Product Service GmbH
Test Specification	6.1.6.1 In-band unwanted emission

1.438MHz



In-band unwanted emis

*RBW 10 kHz

*VBW 30 kHz

Ref 10 dBm

*Att 20 dB

*SWT 23 s

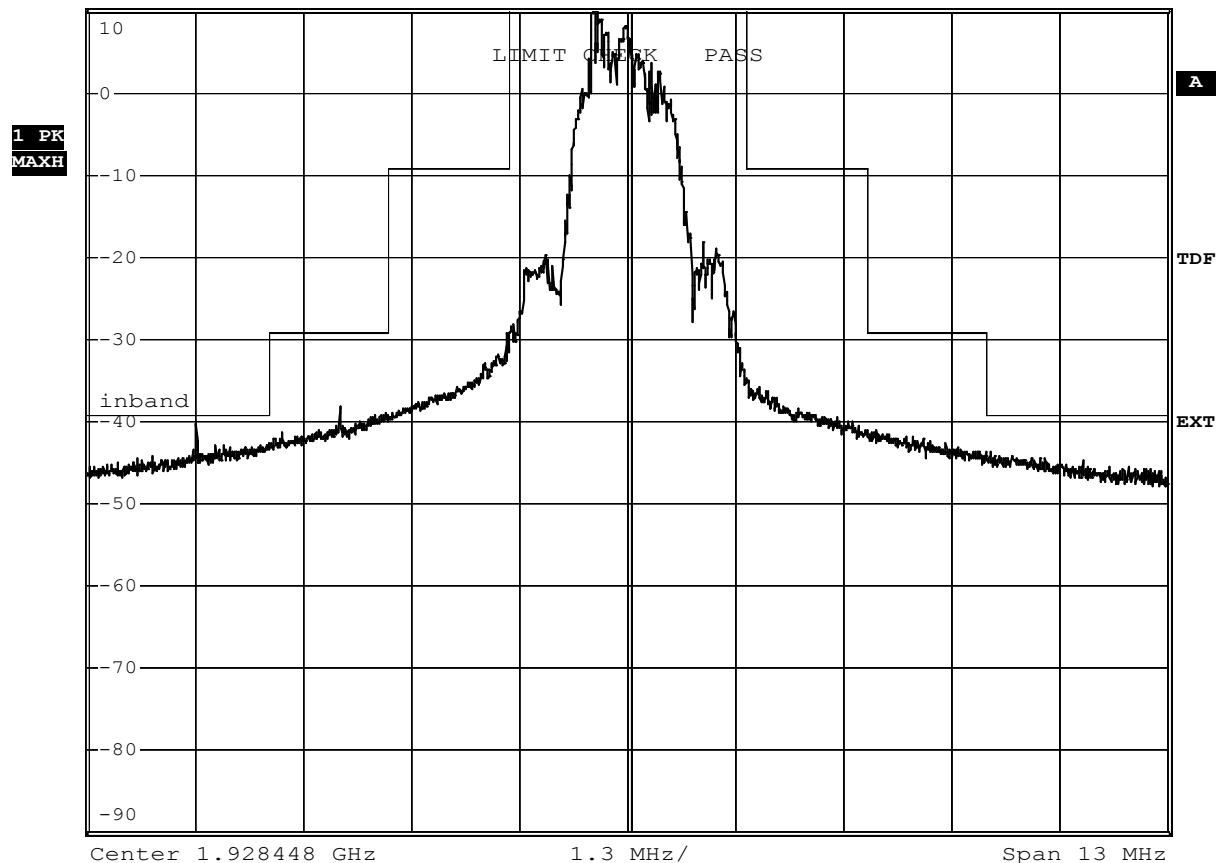

Comment: Ansi C63.17-2006 6.1.6.1

Date: 11.DEC.2008 14:31:34

Measurement diagram

Eurofins Product Service GmbH
Storkower Str. 38c, D-15526 Reichenwalde, Germany

FCC Part 15.323(d.1) Out-of-band emission

Testprocedure ANSI 63.17-2006 6.1.6.2 UPCS

EUT	DECT RFP
Model	RFP5 1G9
Applicant	Polycom Denmark ApS
Temperature	23°C
Test Site / Operator	Eurofins Product Service GmbH
Test Specification	6.1.6.2 Out-of-band emission

measurement on the lowest carrier
Carrier=1921.536MHz



Out-of-band emission

*RBW 10 kHz

*VBW 30 kHz

Ref 10 dBm

*Att 20 dB

*SWT 23 s

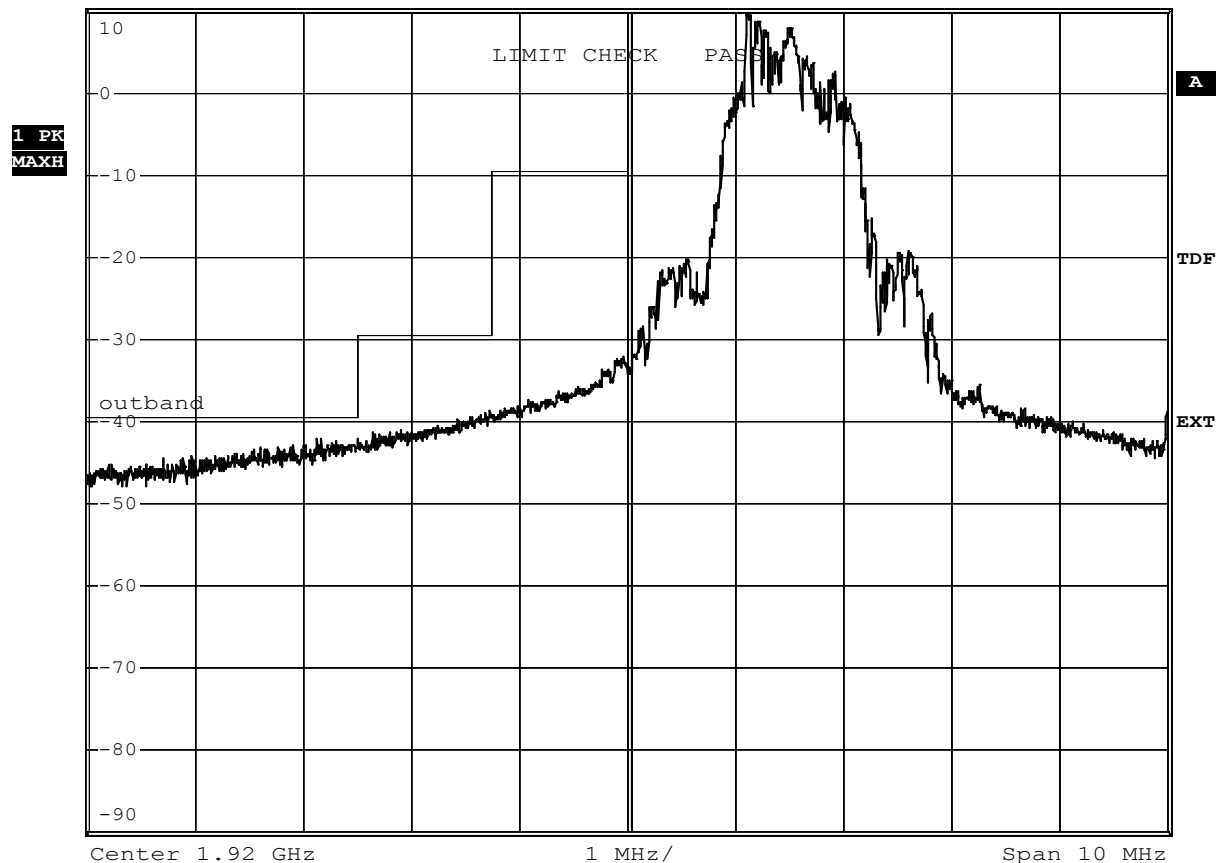

Comment: Ansi C63.17-2006 6.1.6.2

Date: 11.DEC.2008 14:16:24

Measurement diagram

Eurofins Product Service GmbH
Storkower Str. 38c, D-15526 Reichenwalde, Germany

FCC Part 15.323(d.1) Out-of-band emission

Testprocedure ANSI 63.17-2006 6.1.6.2 UPCS

EUT	DECT RFP
Model	RFP5 1G9
Applicant	Polycom Denmark ApS
Temperature	23°C
Test Site / Operator	Eurofins Product Service GmbH
Test Specification	6.1.6.2 Out-of-band emission

measurement on the highest carrier
Carrier=1928.448MHz



Out-of-band emission

*RBW 10 kHz

*VBW 30 kHz

Ref 10 dBm

*Att 20 dB

*SWT 23 s

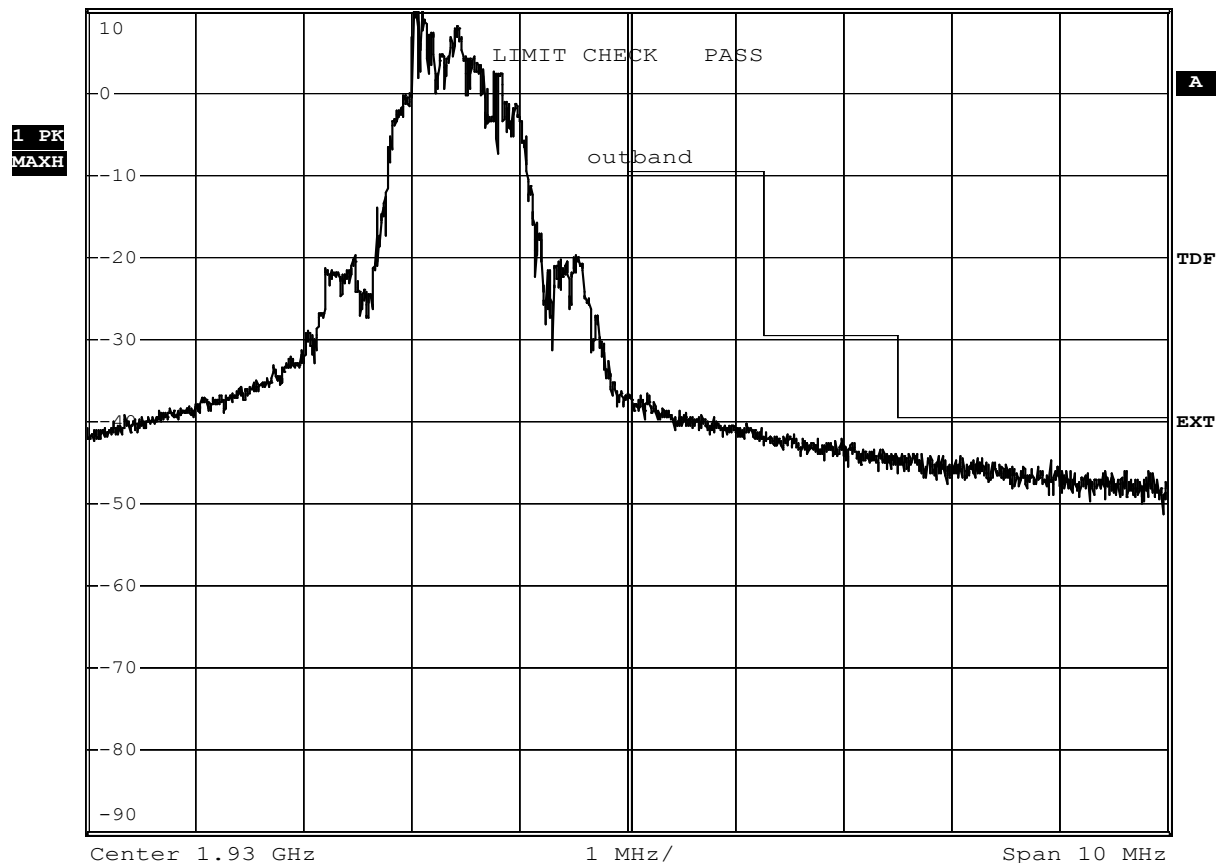

Comment: Ansi C63.17-2006 6.1.6.2

Date: 11.DEC.2008 14:34:21

Measurement diagram

Eurofins Product Service GmbH
Storkower Str. 38c, D-15526 Reichenwalde, Germany

Spurious emissions under normal conditions

FCC RULES PART 15, SUBPART D

Approval Holder: POLYCOM KIRK telecom ApS
EUT: DECT RFP
Model: RFP5 1G9 / 1921.536 MHz; 1928.448
Operator: Eurofins Product Service GmbH / Mr. Handrik
Test Conditions: 25°C / Vnom.: 48 V DC
Test Specification: Fully anechoic chamber / mode: Tx
Comment 1: Dist.: 3m, Ant.: HK 116,
Comment 2: Freq:179.789MHz Pmax:-63.48dBm RBW: 100 kHz

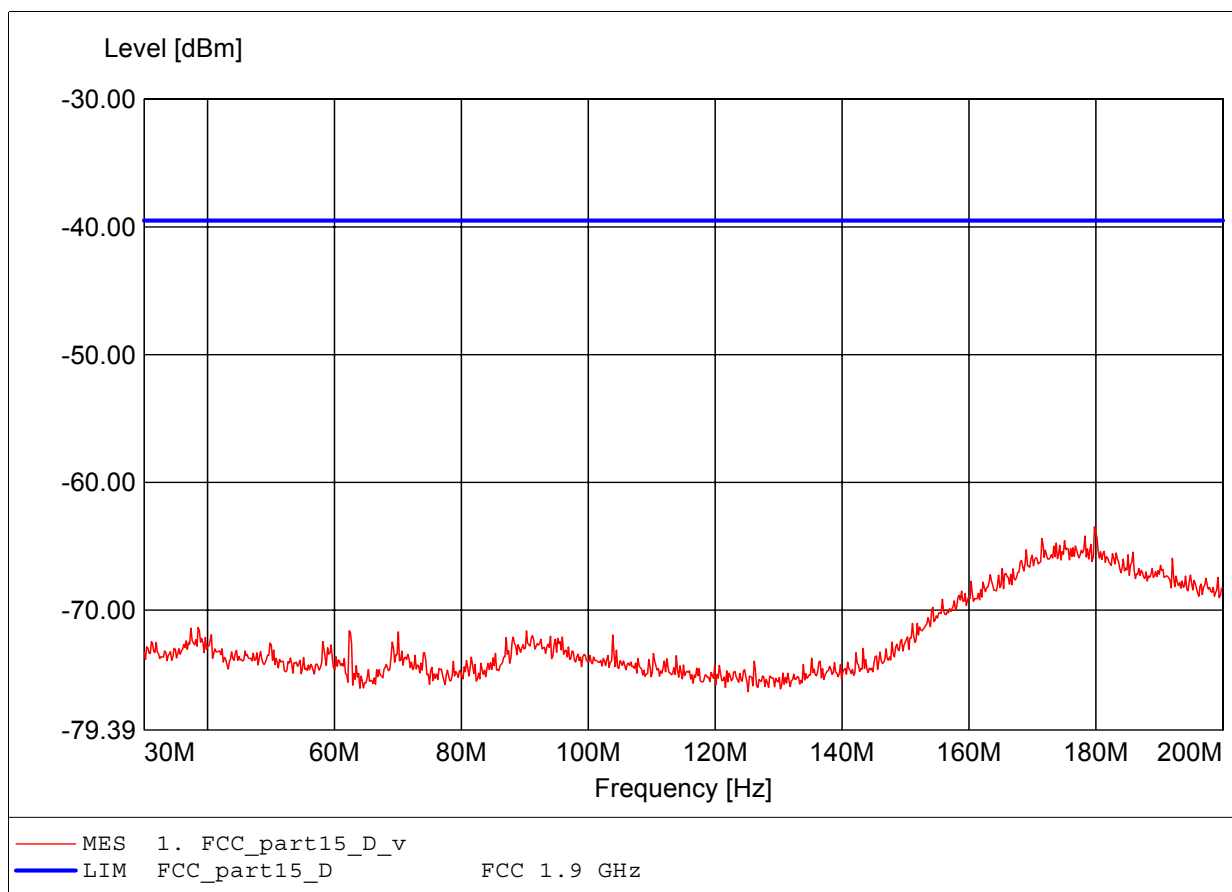

Spurious emissions under normal conditions

FCC RULES PART 15, SUBPART D

Approval Holder: POLYCOM KIRK telecom ApS
EUT: DECT RFP
Model: RFP5 1G9 / 1921.536 MHz; 1928.448
Operator: Eurofins Product Service GmbH / Mr. Handrik
Test Conditions: 25°C / Vnom.: 48 V DC
Test Specification: Fully anechoic chamber / mode: Tx
Comment 1: Dist.: 3m, Ant.: HK 116,
Comment 2: Freq:195.278MHz Pmax:-61.49dBm RBW: 100 kHz

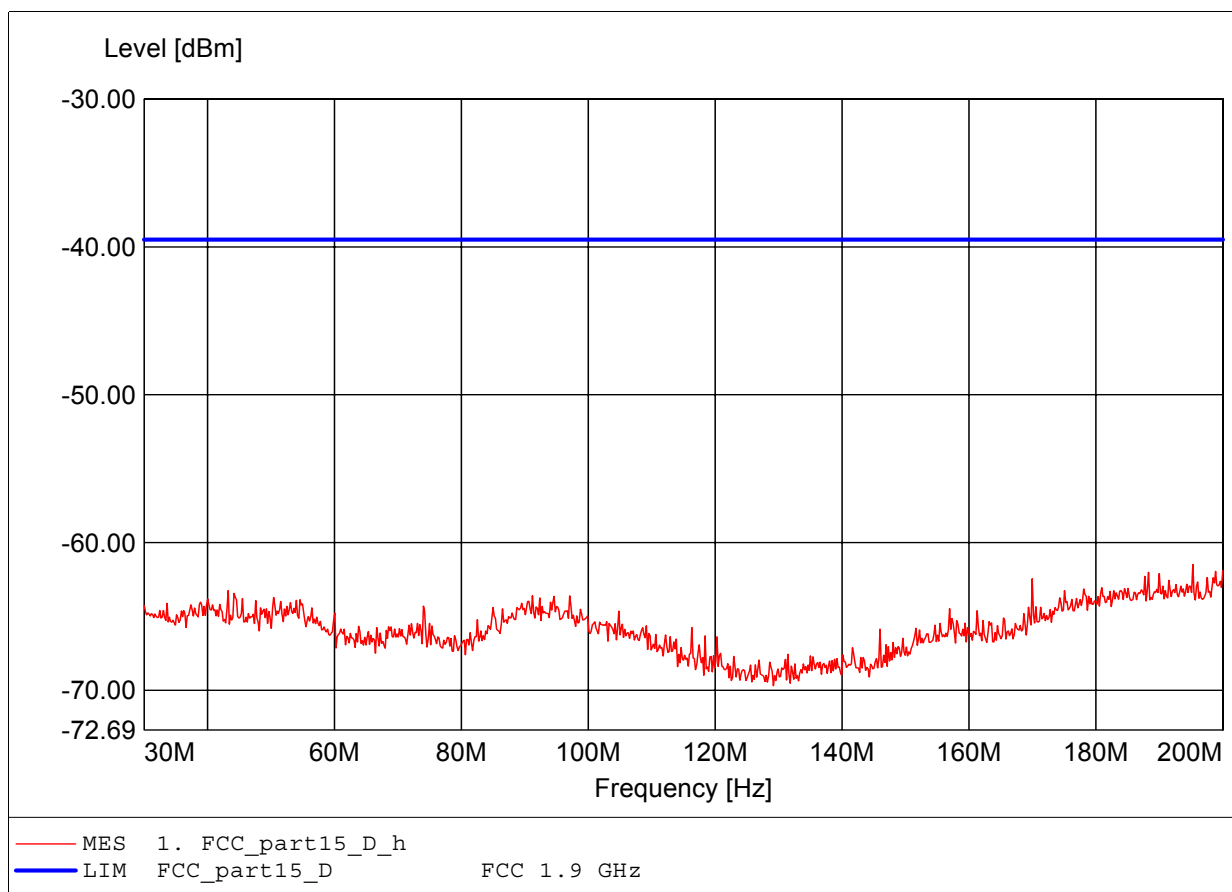

Spurious emissions under normal conditions

FCC RULES PART 15, SUBPART D

Approval Holder: POLYCOM KIRK telecom ApS
EUT: DECT RFP
Model: RFP5 1G9 / 1921.536 MHz; 1928.448
Operator: Eurofins Product Service GmbH / Mr. Handrik
Test Conditions: 25°C / Vnom.: 48 V DC
Test Specification: Fully anechoic chamber / mode: Tx
Comment 1: Dist.: 3m, Ant.: HL 223, ampl.
Comment 2: Freq:991.111MHz Pmax:-72.76dBm RBW: 100 kHz

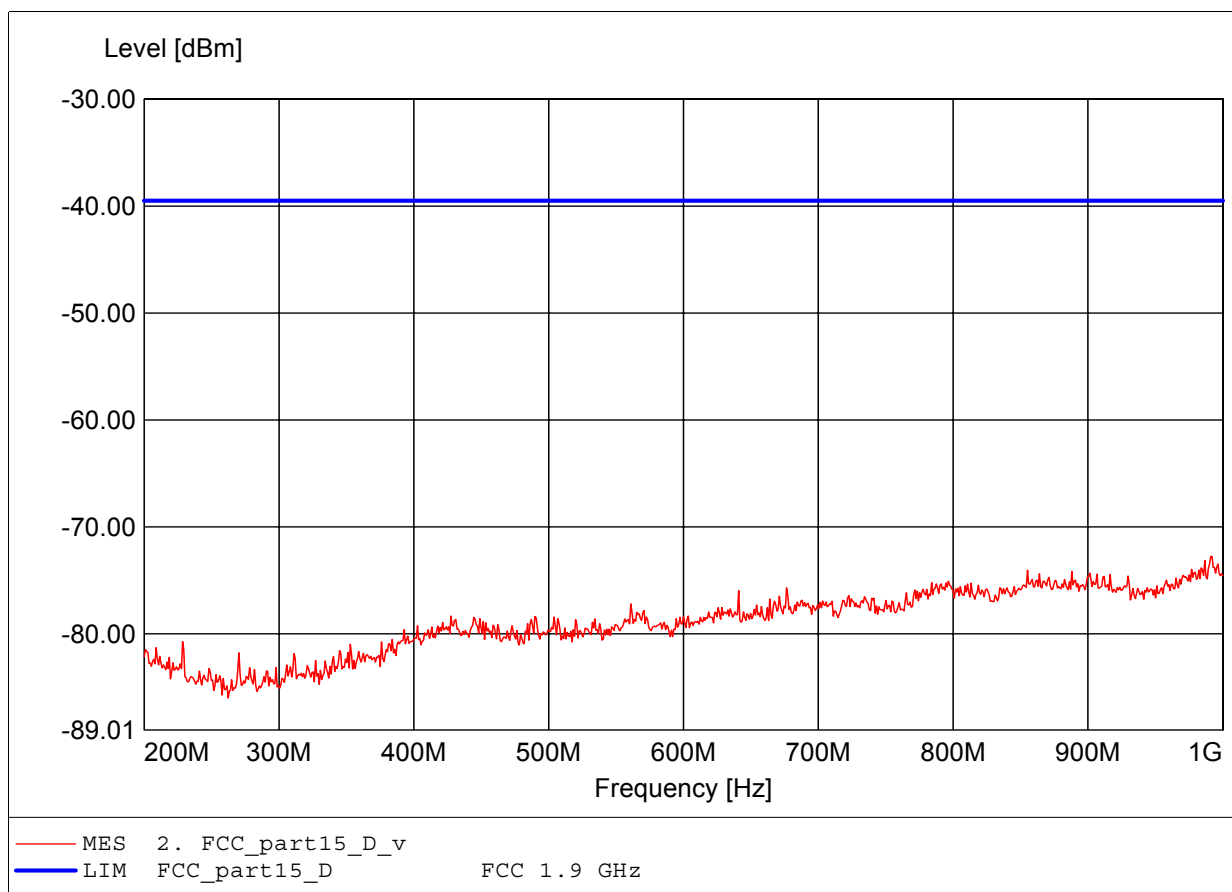

Spurious emissions under normal conditions

FCC RULES PART 15, SUBPART D

Approval Holder: POLYCOM KIRK telecom ApS
EUT: DECT RFP
Model: RFP5 1G9 / 1921.536 MHz; 1928.448
Operator: Eurofins Product Service GmbH / Mr. Handrik
Test Conditions: 25°C / Vnom.: 48 V DC
Test Specification: Fully anechoic chamber / mode: Tx
Comment 1: Dist.: 3m, Ant.: HL 223, ampl.
Comment 2: Freq:992.889MHz Pmax:-76.32dBm RBW: 100 kHz

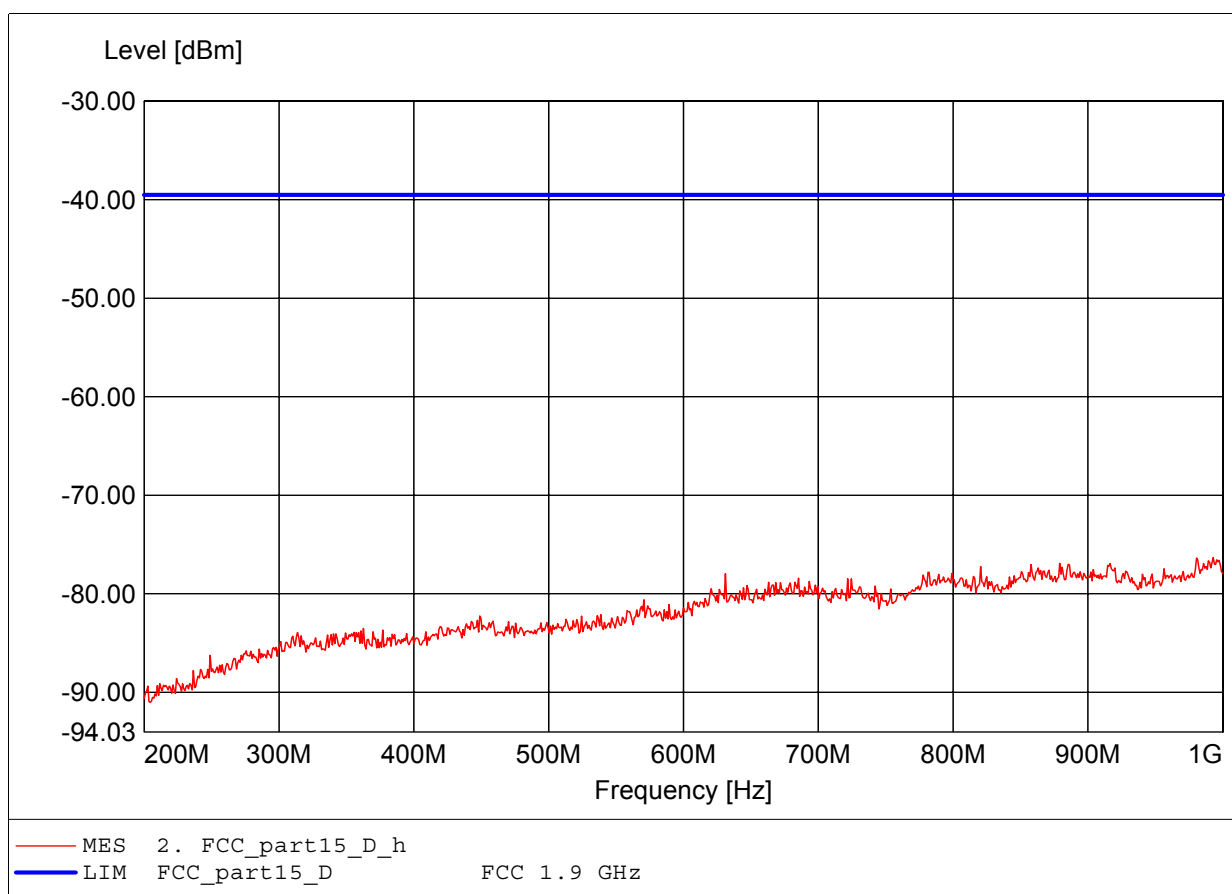

Spurious emissions under normal conditions

FCC RULES PART 15, SUBPART D

Approval Holder: POLYCOM KIRK telecom ApS
EUT: DECT RFP
Model: RFP5 1G9 / 1921.536 MHz; 1928.448
Operator: Eurofins Product Service GmbH / Mr. Handrik
Test Conditions: 25°C / Vnom.: 48 V DC
Test Specification: Fully anechoic chamber / mode: Tx
Comment 1: Dist.: 1m, Ant.: HL 025, ampl.
Comment 2: Freq:1.912GHz Pmax:-50.30dBm RBW: 100 kHz

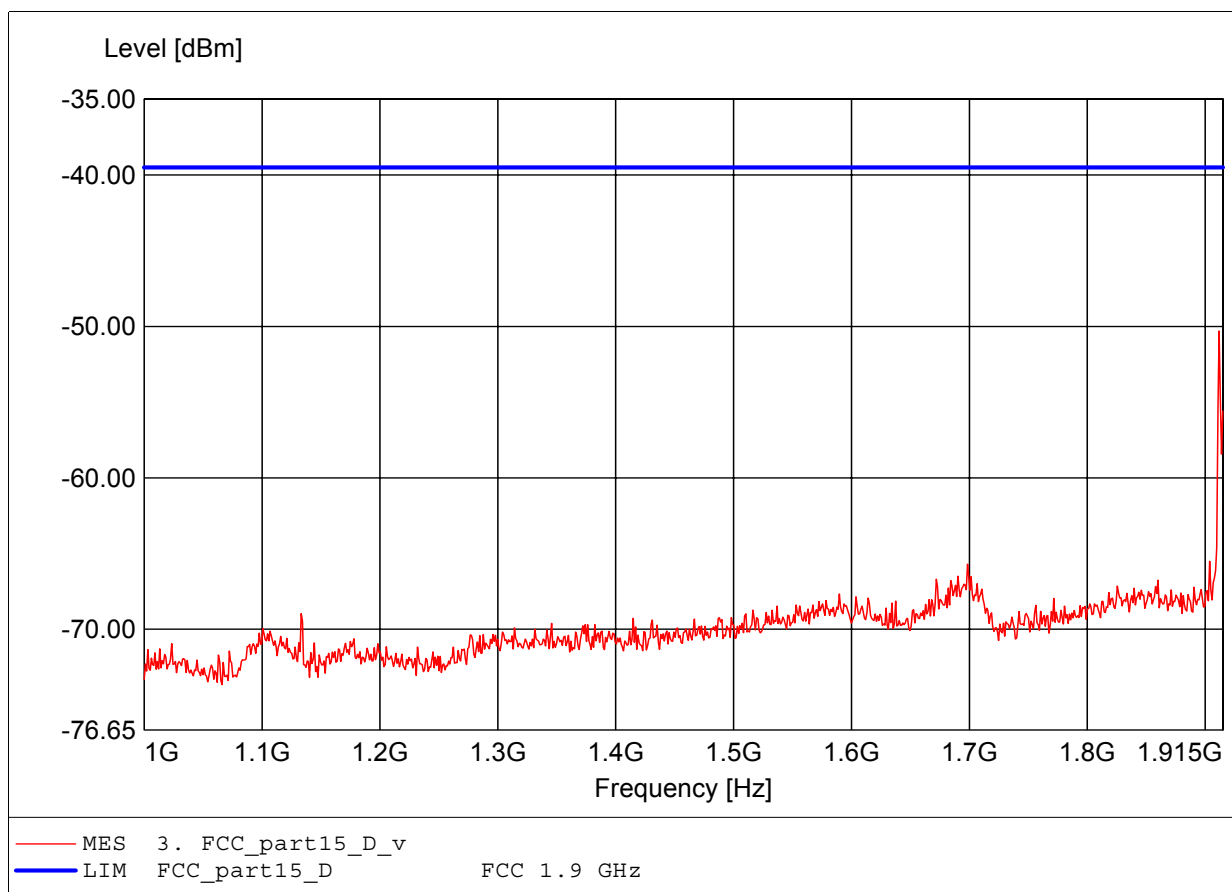

Spurious emissions under normal conditions

FCC RULES PART 15, SUBPART D

Approval Holder: POLYCOM KIRK telecom ApS
EUT: DECT RFP
Model: RFP5 1G9 / 1921.536 MHz; 1928.448
Operator: Eurofins Product Service GmbH / Mr. Handrik
Test Conditions: 25°C / Vnom.: 48 V DC
Test Specification: Fully anechoic chamber / mode: Tx
Comment 1: Dist.: 1m, Ant.: HL 025, ampl.
Comment 2: Freq:1.912GHz Pmax:-55.61dBm RBW: 100 kHz

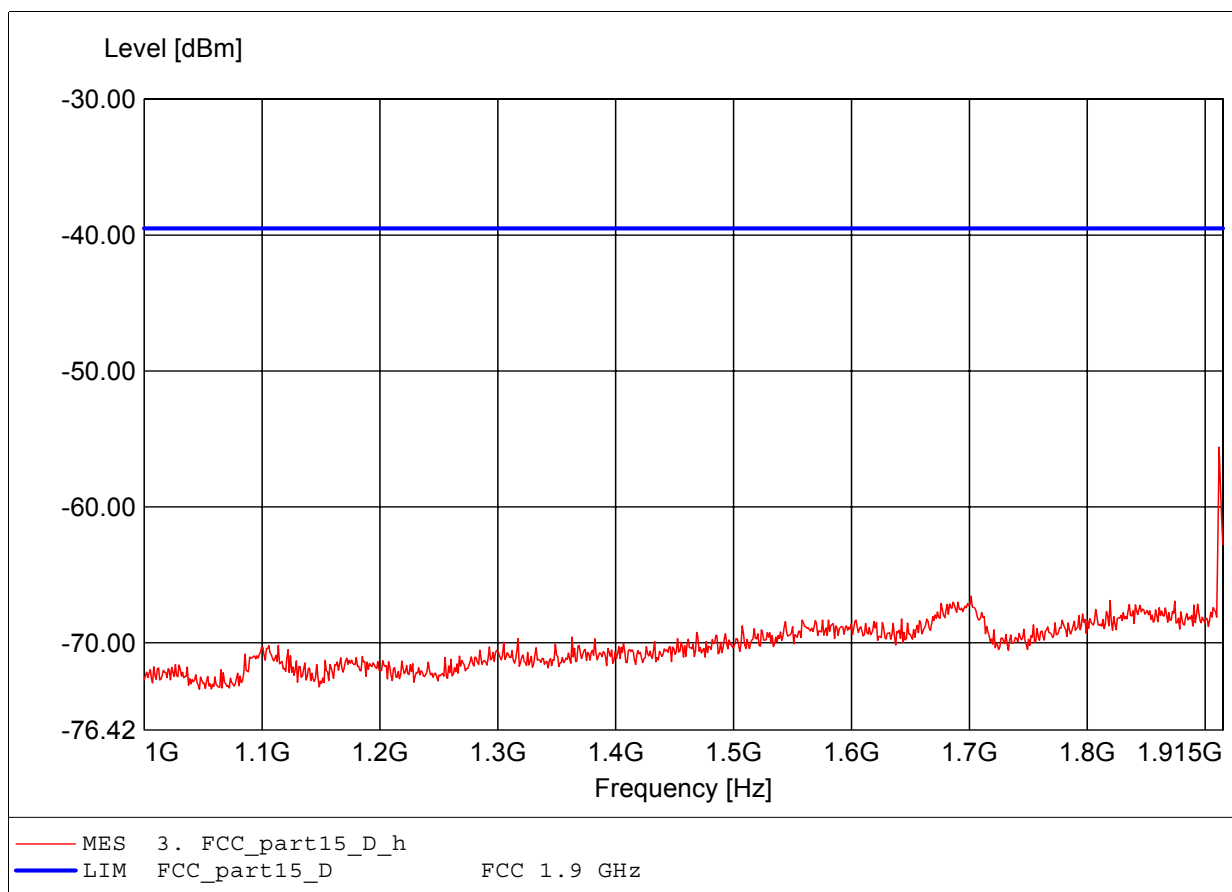

Spurious emissions under normal conditions

FCC PART 15, SUBPART D (ANSI C63.17-1998, Subclause 6.1.6.3)

Approval Holder: POLYCOM KIRK telecom ApS
EUT: DECT RFP
Model: RFP5 1G9 / 1921.536 MHz; 1928.448
Operator: Eurofins Product Service GmbH / Mr. Handrik
Test Conditions: 25°C / Vnom.: 48 V DC
Test Specification: Fully anechoic chamber / mode: Tx
Comment 1: Dist.: 1m, Ant.: HL 025, ampl.
Comment 2: Freq:1.930GHz Pmax:-43.67dBm RBW: 10 kHz

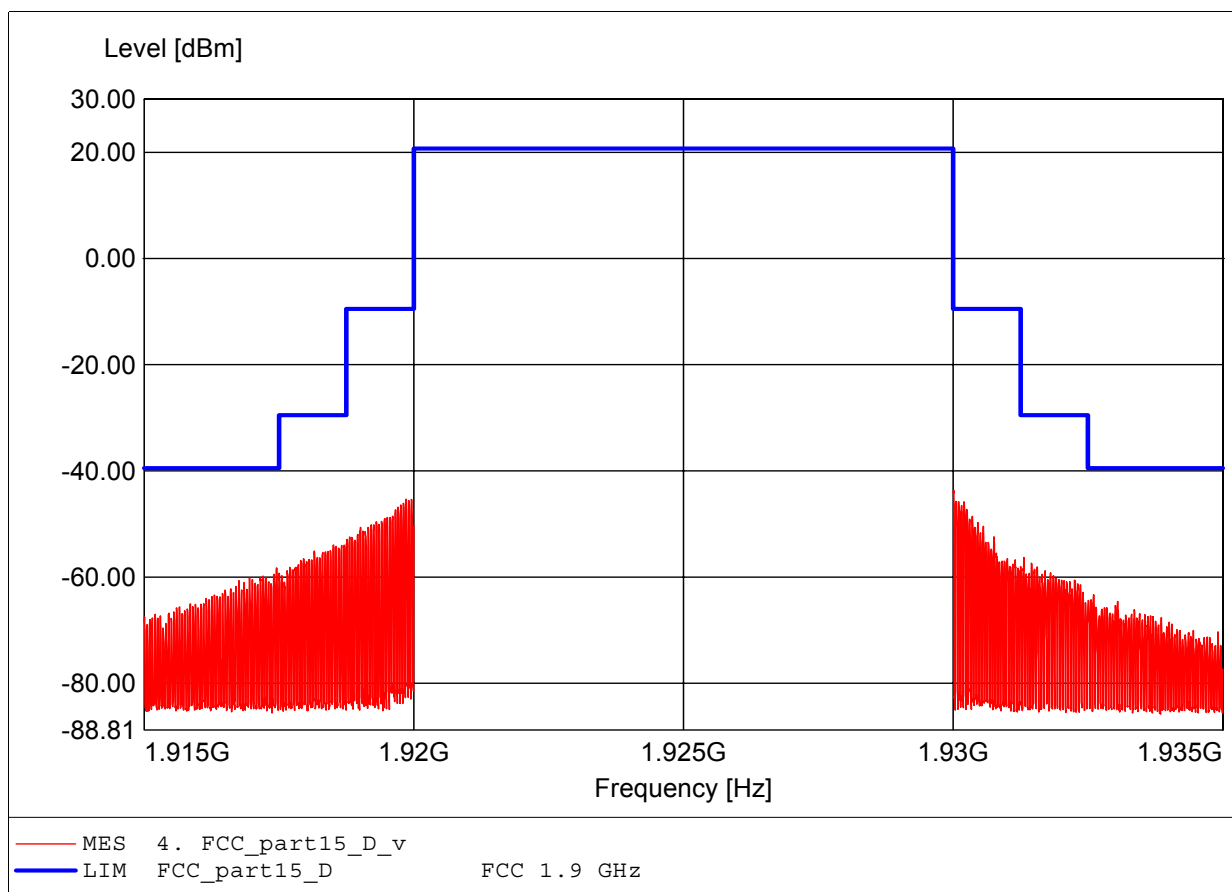

Spurious emissions under normal conditions

FCC PART 15, SUBPART D (ANSI C63.17-1998, Subclause 6.1.6.3)

Approval Holder: POLYCOM KIRK telecom ApS
EUT: DECT RFP
Model: RFP5 1G9 / 1921.536 MHz; 1928.448
Operator: Eurofins Product Service GmbH / Mr. Handrik
Test Conditions: 25°C / Vnom.: 48 V DC
Test Specification: Fully anechoic chamber / mode: Tx
Comment 1: Dist.: 1m, Ant.: HL 025, ampl.
Comment 2: Freq:1.930GHz Pmax:-47.79dBm RBW: 10 kHz

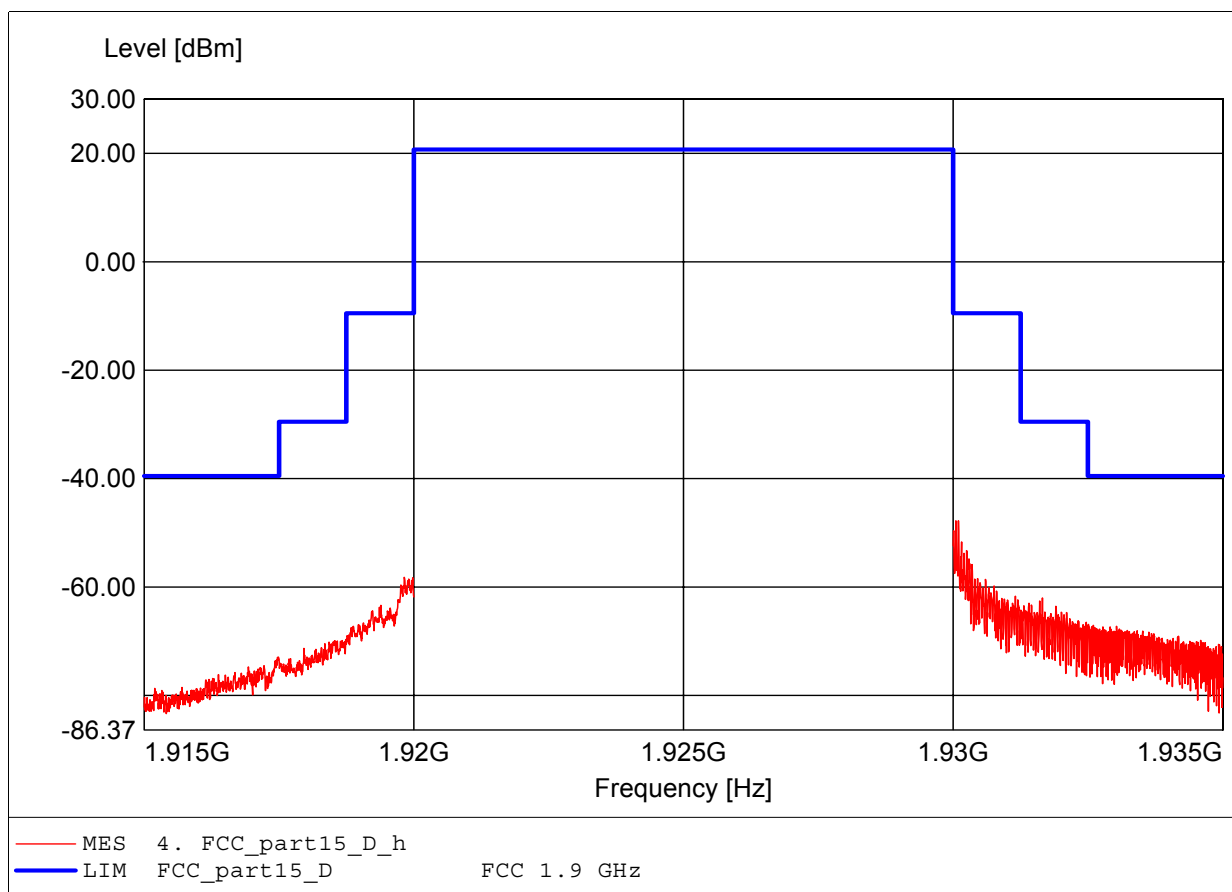

Spurious emissions under normal conditions

FCC RULES PART 15, SUBPART D

Approval Holder: POLYCOM KIRK telecom ApS
EUT: DECT RFP
Model: RFP5 1G9 / 1921.536 MHz; 1928.448
Operator: Eurofins Product Service GmbH / Mr. Handrik
Test Conditions: 25°C / Vnom.: 48 V DC
Test Specification: Fully anechoic chamber / mode: Tx
Comment 1: Dist.: 1m, Ant.: HL 025, ampl.
Comment 2: Freq:3.952GHz Pmax:-56.37dBm RBW: 100 kHz

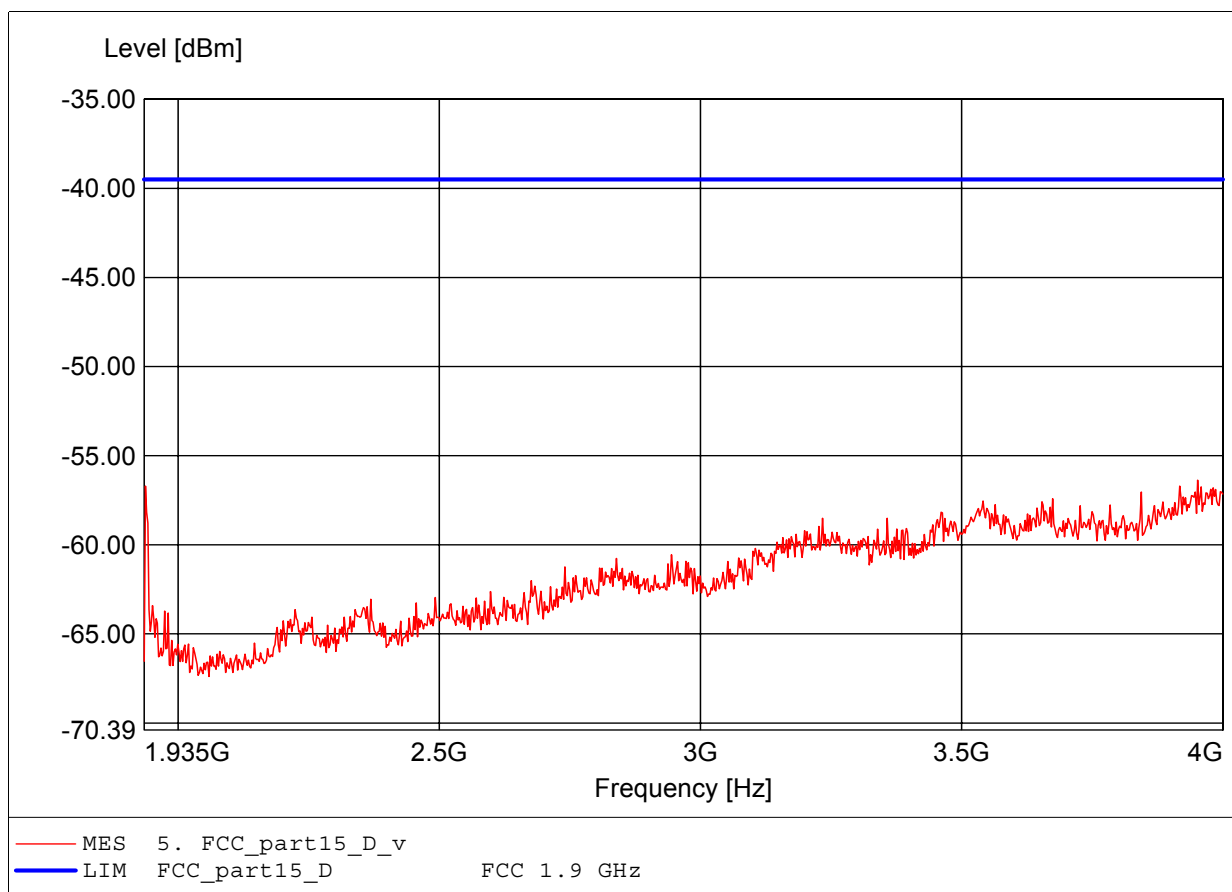

Spurious emissions under normal conditions

FCC RULES PART 15, SUBPART D

Approval Holder: POLYCOM KIRK telecom ApS
EUT: DECT RFP
Model: RFP5 1G9 / 1921.536 MHz; 1928.448
Operator: Eurofins Product Service GmbH / Mr. Handrik
Test Conditions: 25°C / Vnom.: 48 V DC
Test Specification: Fully anechoic chamber / mode: Tx
Comment 1: Dist.: 1m, Ant.: HL 025, ampl.
Comment 2: Freq:3.858GHz Pmax:-52.15dBm RBW: 100 kHz

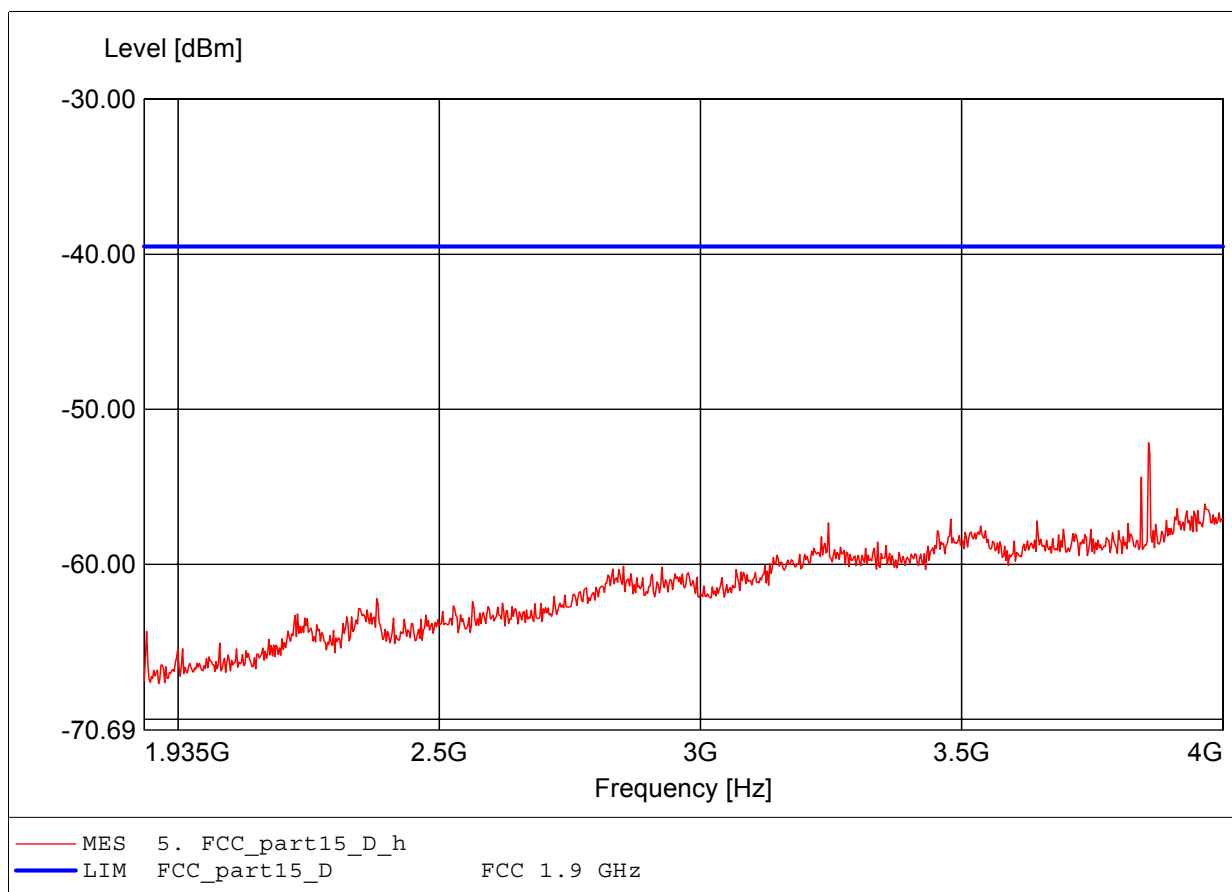

Spurious emissions under normal conditions

FCC PART 15, SUBPART D (ANSI C63.17-1998, Subclause 6.1.6.3)

Approval Holder: POLYCOM KIRK telecom ApS
EUT: DECT RFP
Model: RFP5 1G9 / 1921.536 MHz; 1928.448
Operator: Eurofins Product Service GmbH / Mr. Handrik
Test Conditions: 25°C / Vnom.: 48 V DC
Test Specification: Fully anechoic chamber / mode: Tx
Comment 1: Dist.: 1m, Ant.: HL 025, ampl.
Comment 2: Freq:3.856GHz Pmax:-61.99dBm RBW:10 kHz

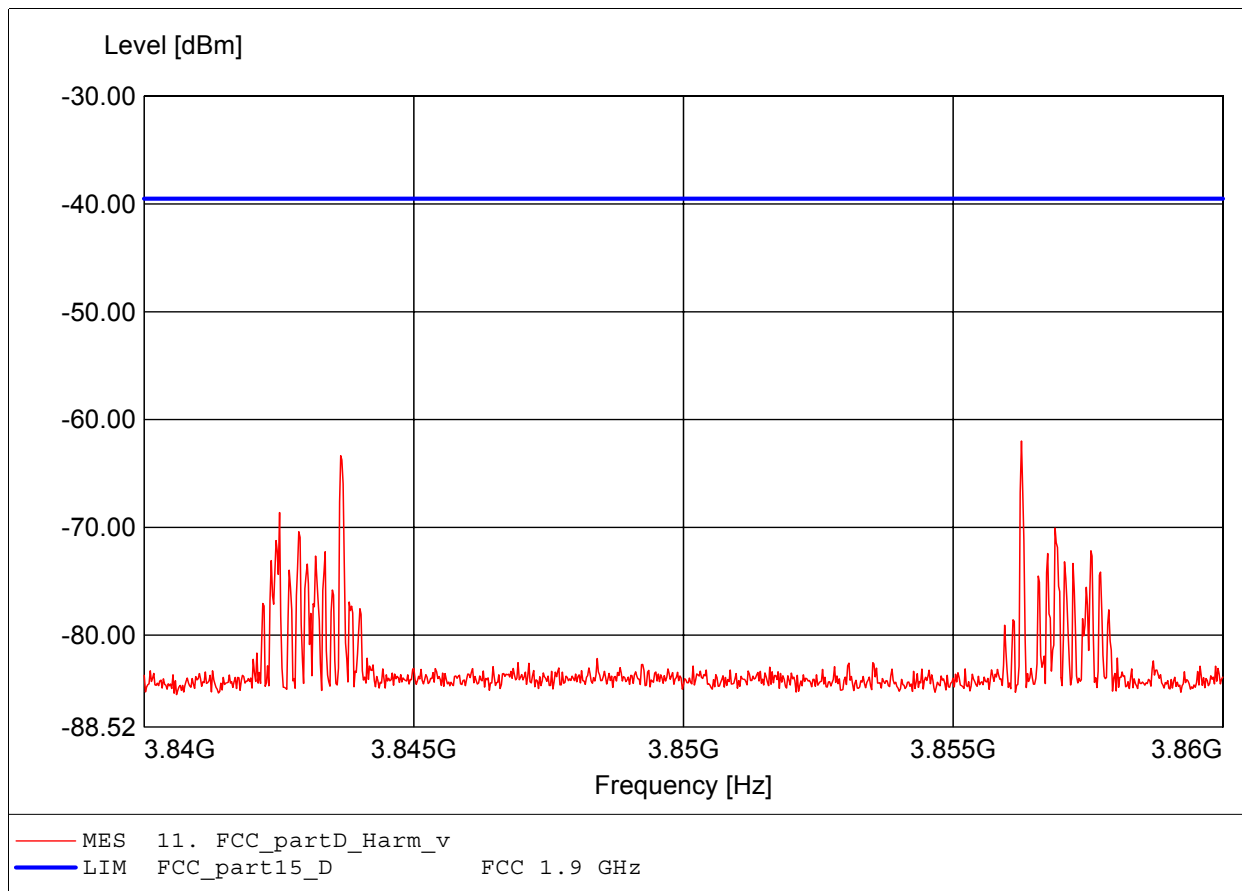

Spurious emissions under normal conditions

FCC PART 15, SUBPART D (ANSI C63.17-1998, Subclause 6.1.6.3)

Approval Holder: POLYCOM KIRK telecom ApS
EUT: DECT RFP
Model: RFP5 1G9 / 1921.536 MHz; 1928.448
Operator: Eurofins Product Service GmbH / Mr. Handrik
Test Conditions: 25°C / Vnom.: 48 V DC
Test Specification: Fully anechoic chamber / mode: Tx
Comment 1: Dist.: 1m, Ant.: HL 025, ampl.
Comment 2: Freq:3.856GHz Pmax:-59.14dBm RBW:10 kHz

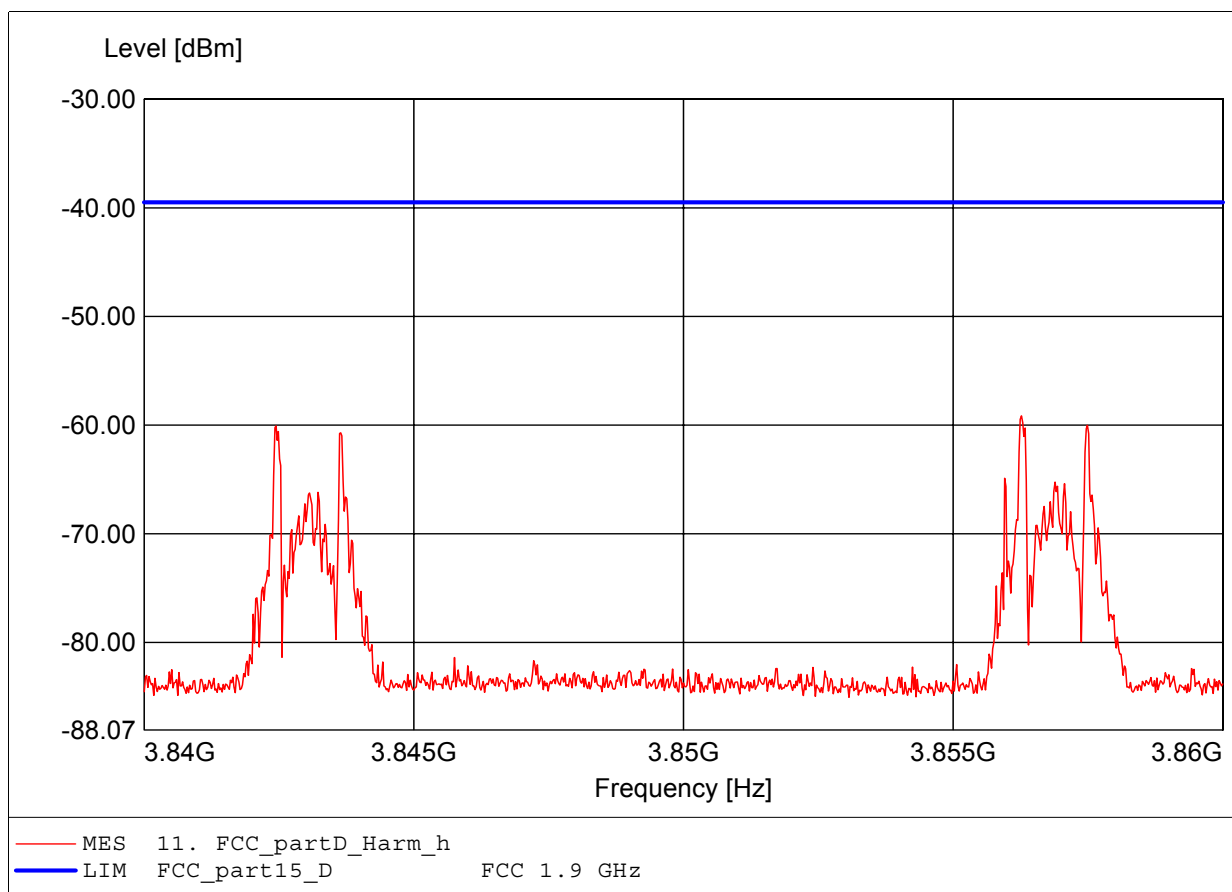

Spurious emissions under normal conditions

FCC PART 15, SUBPART D (ANSI C63.17-1998, Subclause 6.1.6.3)

Approval Holder: POLYCOM KIRK telecom ApS
EUT: DECT RFP
Model: RFP5 1G9 / 1921.536 MHz; 1928.448
Operator: Eurofins Product Service GmbH / Mr. Handrik
Test Conditions: 25°C / Vnom.: 48 V DC
Test Specification: Fully anechoic chamber / mode: Tx
Comment 1: Dist.: 1m, Ant.: HL 025, ampl.
Comment 2: Freq:5.764GHz Pmax:-70.06dBm RBW:10 kHz

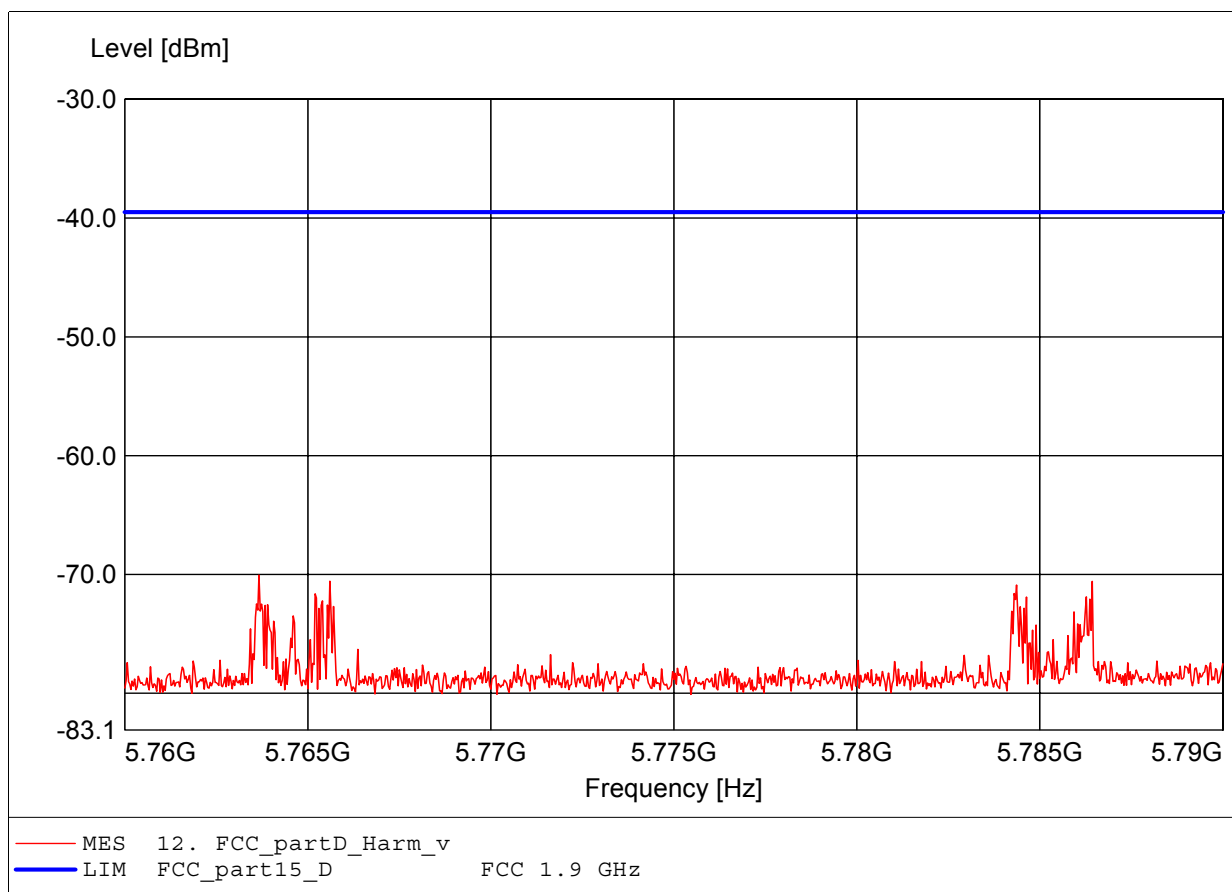

Spurious emissions under normal conditions

FCC PART 15, SUBPART D (ANSI C63.17-1998, Subclause 6.1.6.3)

Approval Holder: POLYCOM KIRK telecom ApS
EUT: DECT RFP
Model: RFP5 1G9 / 1921.536 MHz; 1928.448
Operator: Eurofins Product Service GmbH / Mr. Handrik
Test Conditions: 25°C / Vnom.: 48 V DC
Test Specification: Fully anechoic chamber / mode: Tx
Comment 1: Dist.: 1m, Ant.: HL 025, ampl.
Comment 2: Freq:5.764GHz Pmax:-66.10dBm RBW:10 kHz

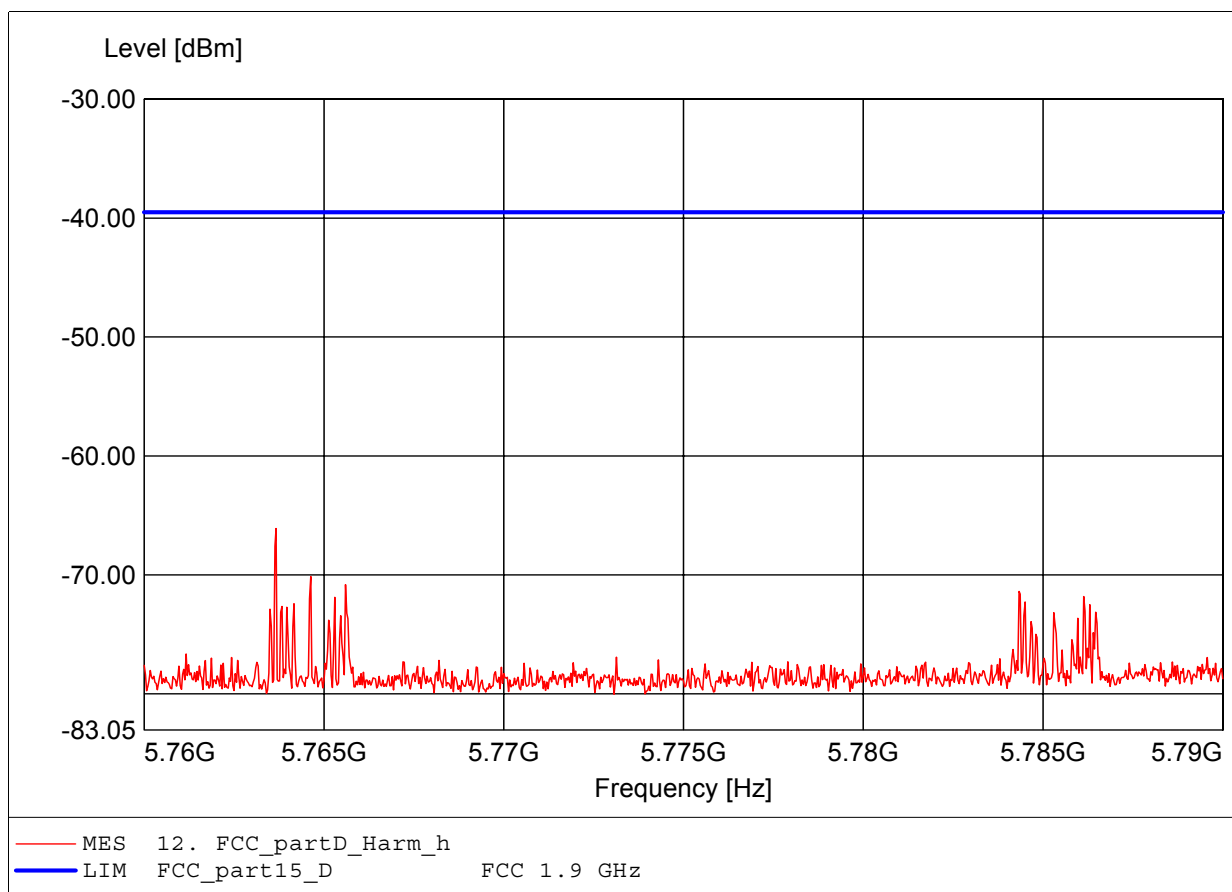

Spurious emissions under normal conditions

FCC PART 15, SUBPART D (ANSI C63.17-1998, Subclause 6.1.6.3)

Approval Holder: POLYCOM KIRK telecom ApS
EUT: DECT RFP
Model: RFP5 1G9 / 1921.536 MHz; 1928.448
Operator: Eurofins Product Service GmbH / Mr. Handrik
Test Conditions: 25°C / Vnom.: 48 V DC
Test Specification: Fully anechoic chamber / mode: Tx
Comment 1: Dist.: 1m, Ant.: HL 025, ampl.
Comment 2: Freq:7.712GHz Pmax:-59.68dBm RBW:10 kHz

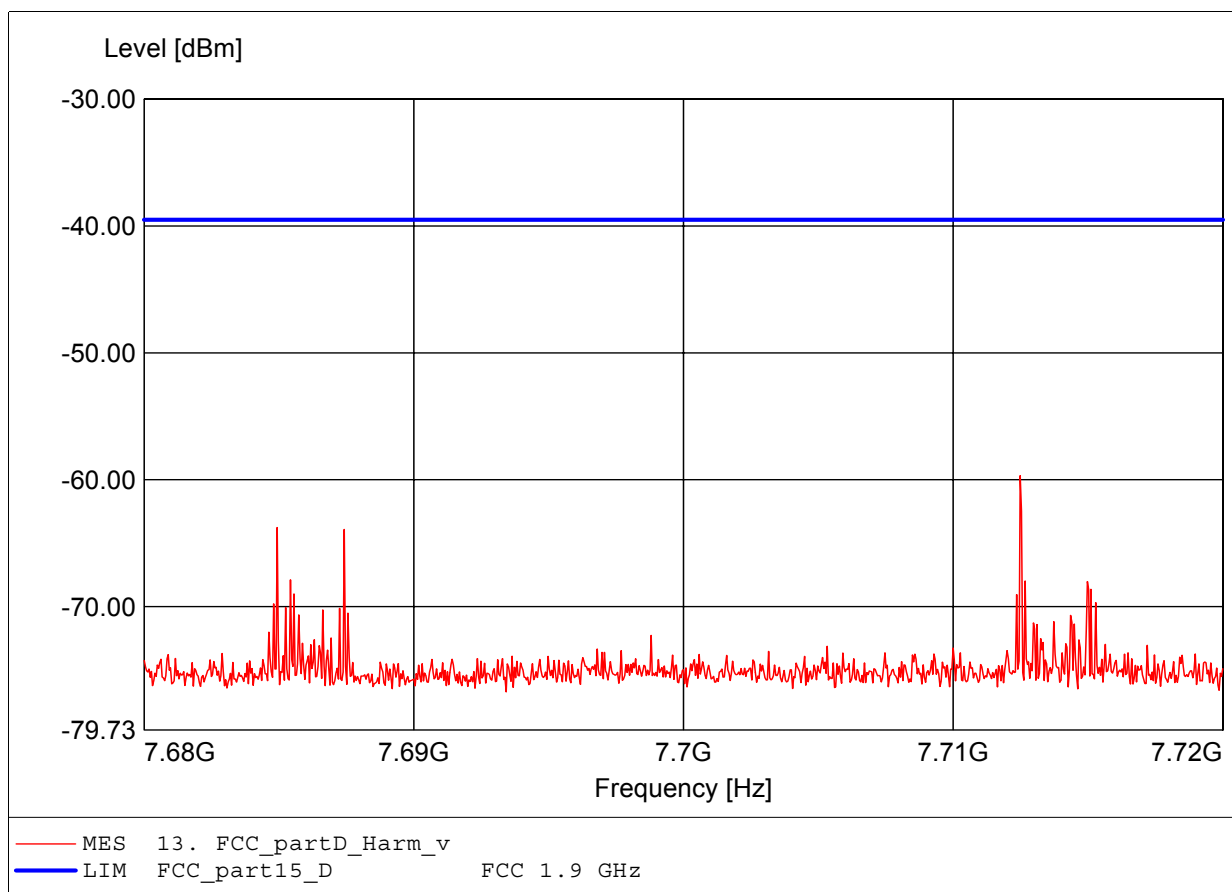

Spurious emissions under normal conditions

FCC PART 15, SUBPART D (ANSI C63.17-1998, Subclause 6.1.6.3)

Approval Holder: POLYCOM KIRK telecom ApS
EUT: DECT RFP
Model: RFP5 1G9 / 1921.536 MHz; 1928.448
Operator: Eurofins Product Service GmbH / Mr. Handrik
Test Conditions: 25°C / Vnom.: 48 V DC
Test Specification: Fully anechoic chamber / mode: Tx
Comment 1: Dist.: 1m, Ant.: HL 025, ampl.
Comment 2: Freq:7.687GHz Pmax:-62.08dBm RBW:10 kHz

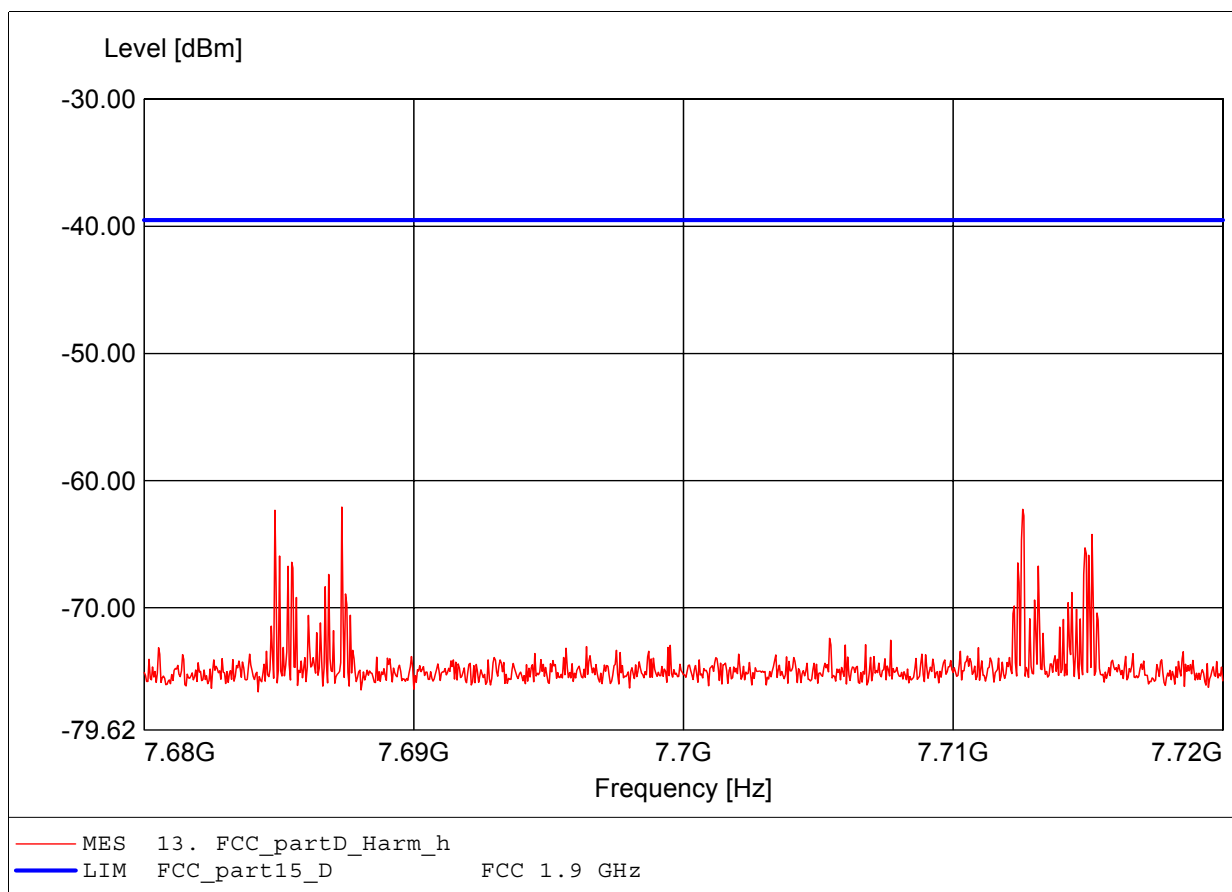

Spurious emissions under normal conditions

FCC PART 15, SUBPART D (ANSI C63.17-1998, Subclause 6.1.6.3)

Approval Holder: POLYCOM KIRK telecom ApS
EUT: DECT RFP
Model: RFP5 1G9 / 1921.536 MHz; 1928.448
Operator: Eurofins Product Service GmbH / Mr. Handrik
Test Conditions: 25°C / Vnom.: 48 V DC
Test Specification: Fully anechoic chamber / mode: Tx
Comment 1: Dist.: 1m, Ant.: HL 025, ampl.
Comment 2: Freq:9.641GHz Pmax:-60.06dBm RBW:10 kHz

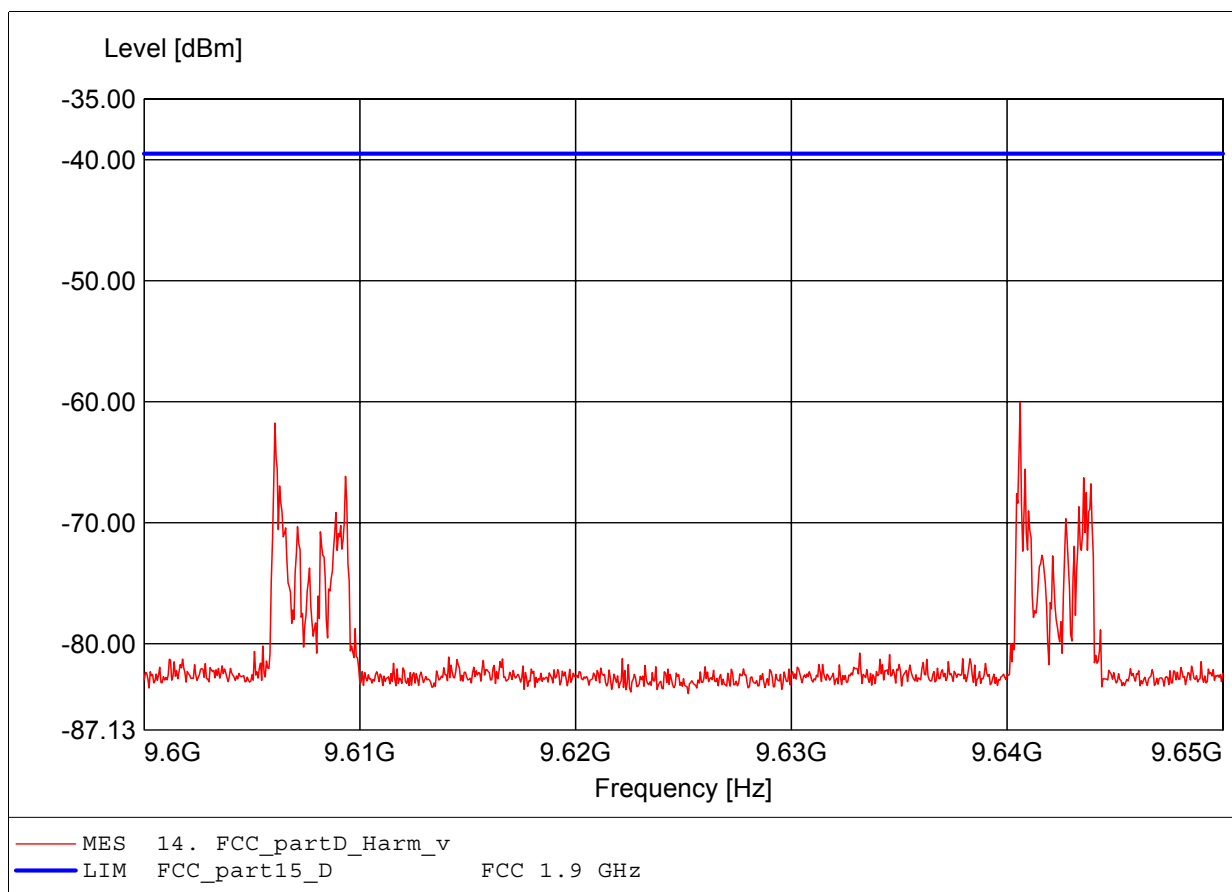

Spurious emissions under normal conditions

FCC PART 15, SUBPART D (ANSI C63.17-1998, Subclause 6.1.6.3)

Approval Holder: POLYCOM KIRK telecom ApS
EUT: DECT RFP
Model: RFP5 1G9 / 1921.536 MHz; 1928.448
Operator: Eurofins Product Service GmbH / Mr. Handrik
Test Conditions: 25°C / Vnom.: 48 V DC
Test Specification: Fully anechoic chamber / mode: Tx
Comment 1: Dist.: 1m, Ant.: HL 025, ampl.
Comment 2: Freq:9.641GHz Pmax:-56.12dBm RBW:10 kHz

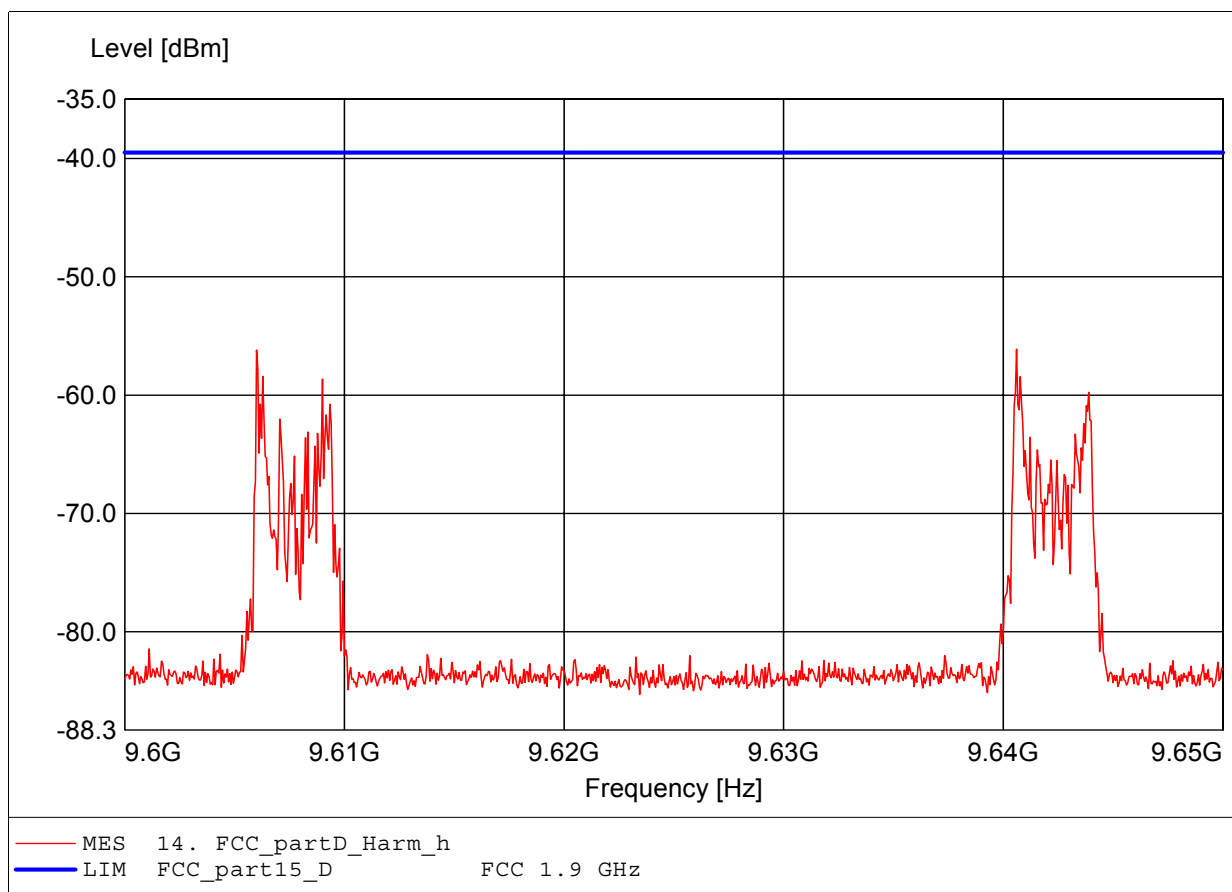

Spurious emissions under normal conditions

FCC PART 15, SUBPART D (ANSI C63.17-1998, Subclause 6.1.6.3)

Approval Holder: POLYCOM KIRK telecom ApS
EUT: DECT RFP
Model: RFP5 1G9 / 1921.536 MHz; 1928.448
Operator: Eurofins Product Service GmbH / Mr. Handrik
Test Conditions: 25°C / Vnom.: 48 V DC
Test Specification: Fully anechoic chamber / mode: Tx
Comment 1: Dist.: 1m, Ant.: HL 025, ampl.
Comment 2: Freq:11.527GHz Pmax:-65.16dBm RBW:10 kHz

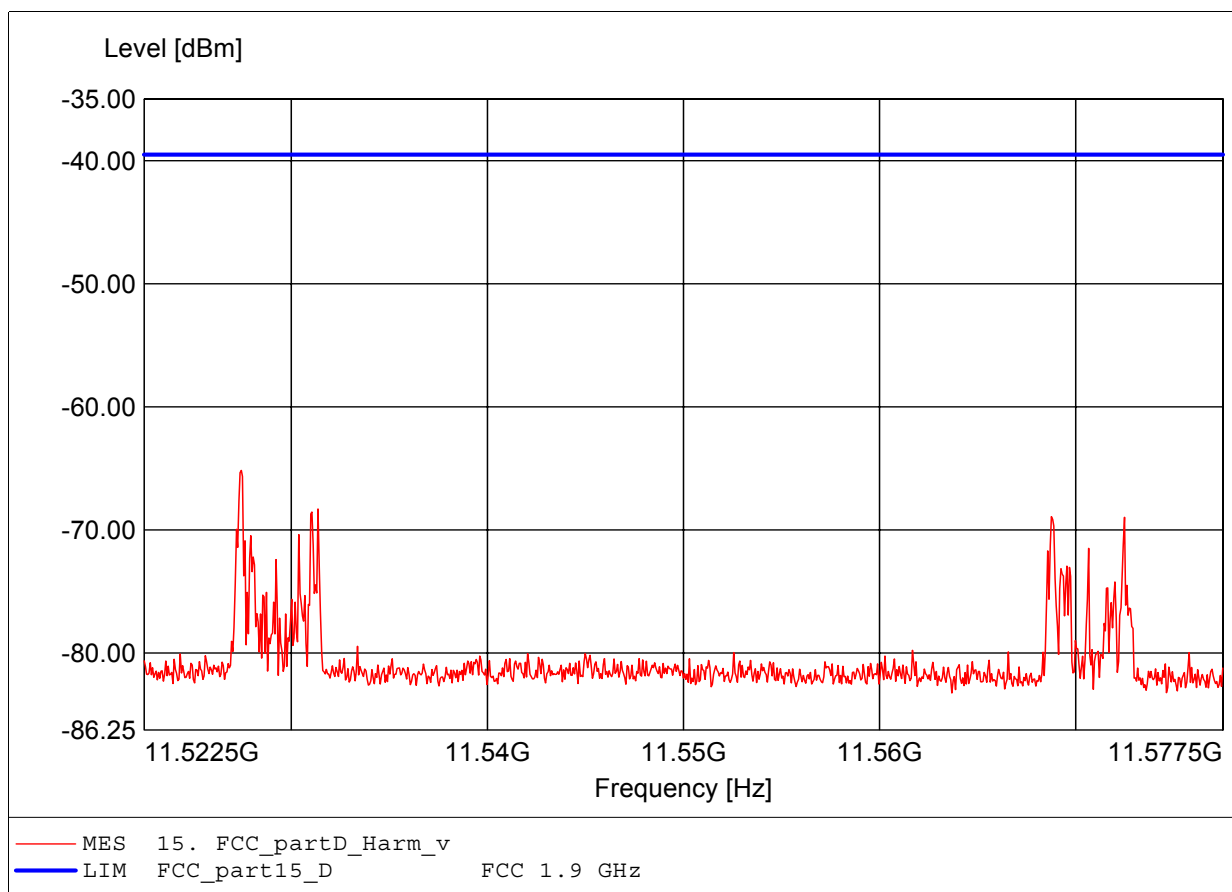

Spurious emissions under normal conditions

FCC PART 15, SUBPART D (ANSI C63.17-1998, Subclause 6.1.6.3)

Approval Holder: POLYCOM KIRK telecom ApS
EUT: DECT RFP
Model: RFP5 1G9 / 1921.536 MHz; 1928.448
Operator: Eurofins Product Service GmbH / Mr. Handrik
Test Conditions: 25°C / Vnom.: 48 V DC
Test Specification: Fully anechoic chamber / mode: Tx
Comment 1: Dist.: 1m, Ant.: HL 025, ampl.
Comment 2: Freq:11.527GHz Pmax:-63.74dBm RBW:10 kHz

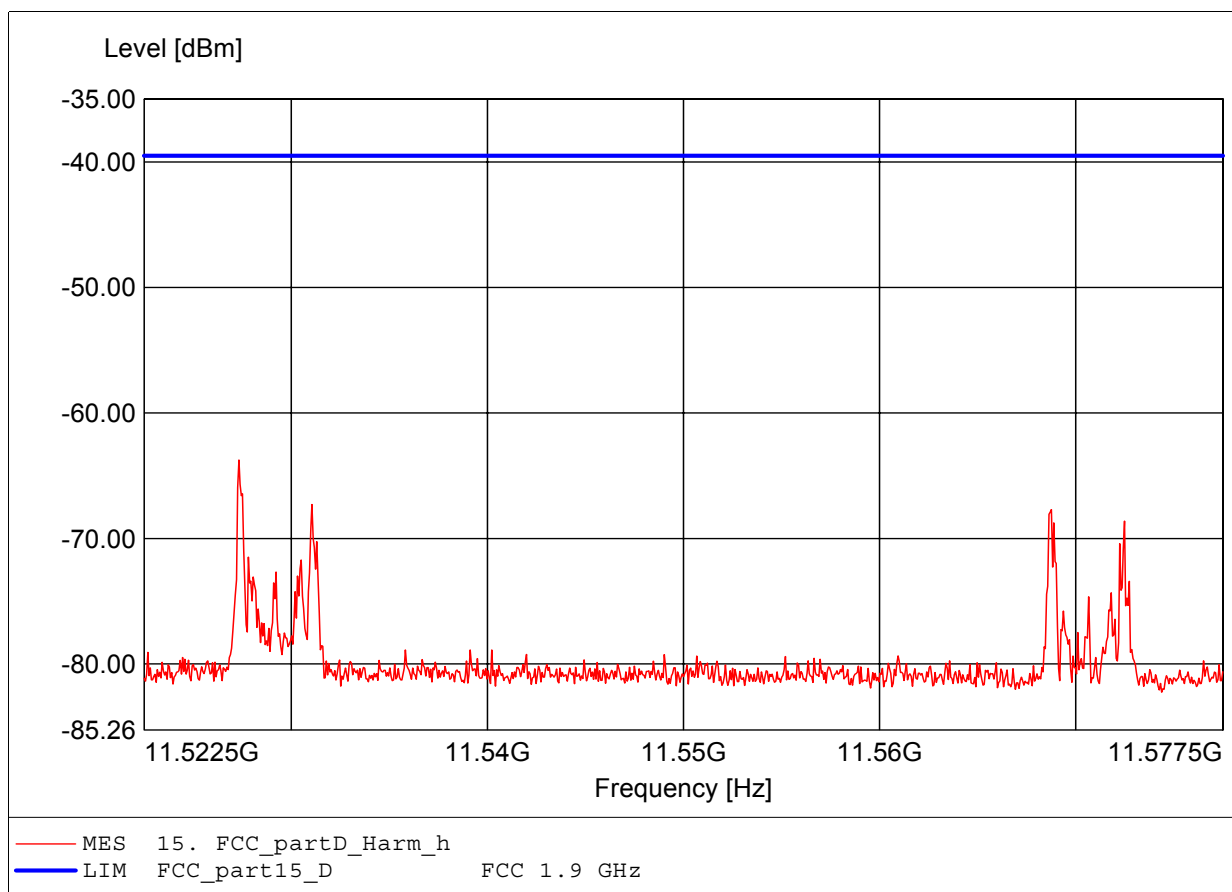

Spurious emissions under normal conditions

FCC PART 15, SUBPART D (ANSI C63.17-1998, Subclause 6.1.6.3)

Approval Holder: POLYCOM KIRK telecom ApS
EUT: DECT RFP
Model: RFP5 1G9 / 1921.536 MHz; 1928.448
Operator: Eurofins Product Service GmbH / Mr. Handrik
Test Conditions: 25°C / Vnom.: 48 V DC
Test Specification: Fully anechoic chamber / mode: Tx
Comment 1: Dist.: 1m, Ant.: HL 025, ampl.
Comment 2: Freq:13.449GHz Pmax:-65.14dBm RBW:10 kHz

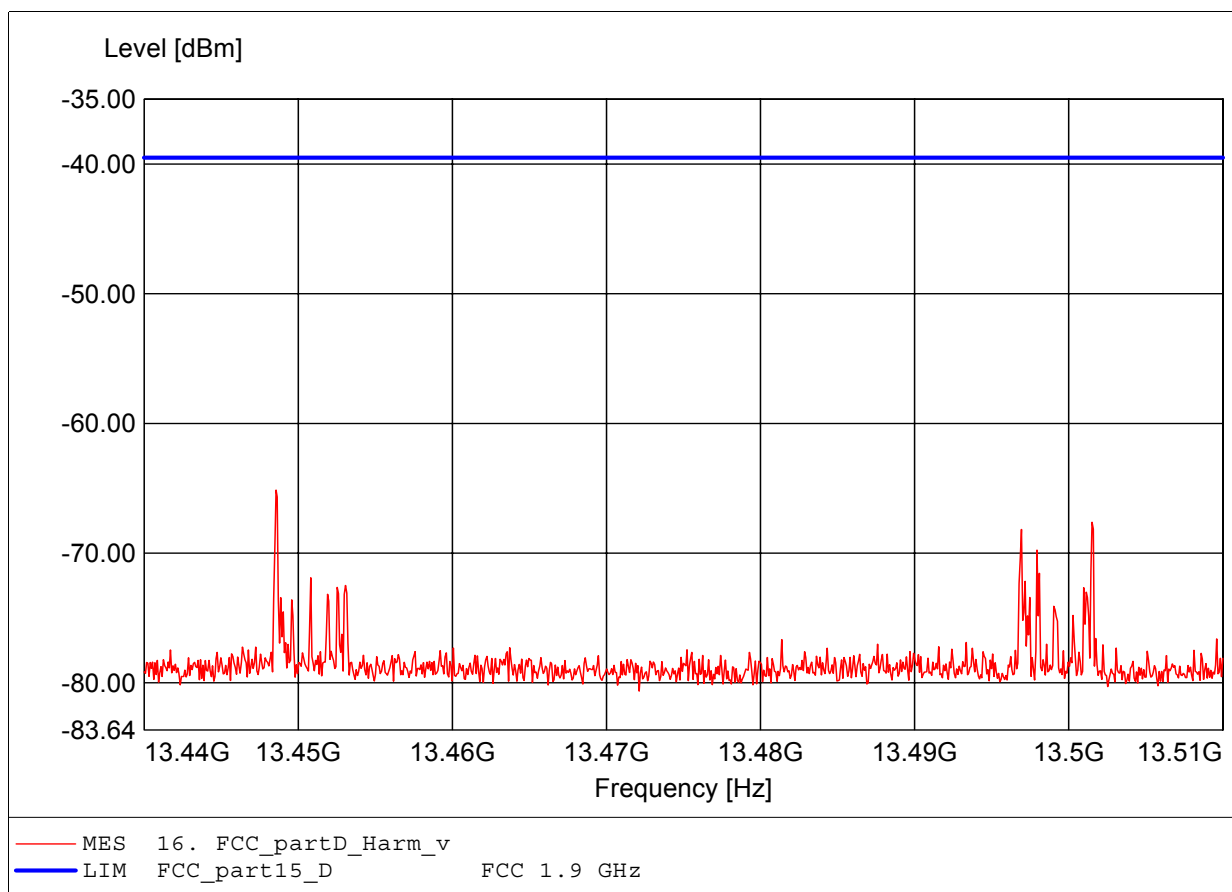

Spurious emissions under normal conditions

FCC PART 15, SUBPART D (ANSI C63.17-1998, Subclause 6.1.6.3)

Approval Holder: POLYCOM KIRK telecom ApS
EUT: DECT RFP
Model: RFP5 1G9 / 1921.536 MHz; 1928.448
Operator: Eurofins Product Service GmbH / Mr. Handrik
Test Conditions: 25°C / Vnom.: 48 V DC
Test Specification: Fully anechoic chamber / mode: Tx
Comment 1: Dist.: 1m, Ant.: HL 025, ampl.
Comment 2: Freq:13.497GHz Pmax:-69.15dBm RBW:10 kHz

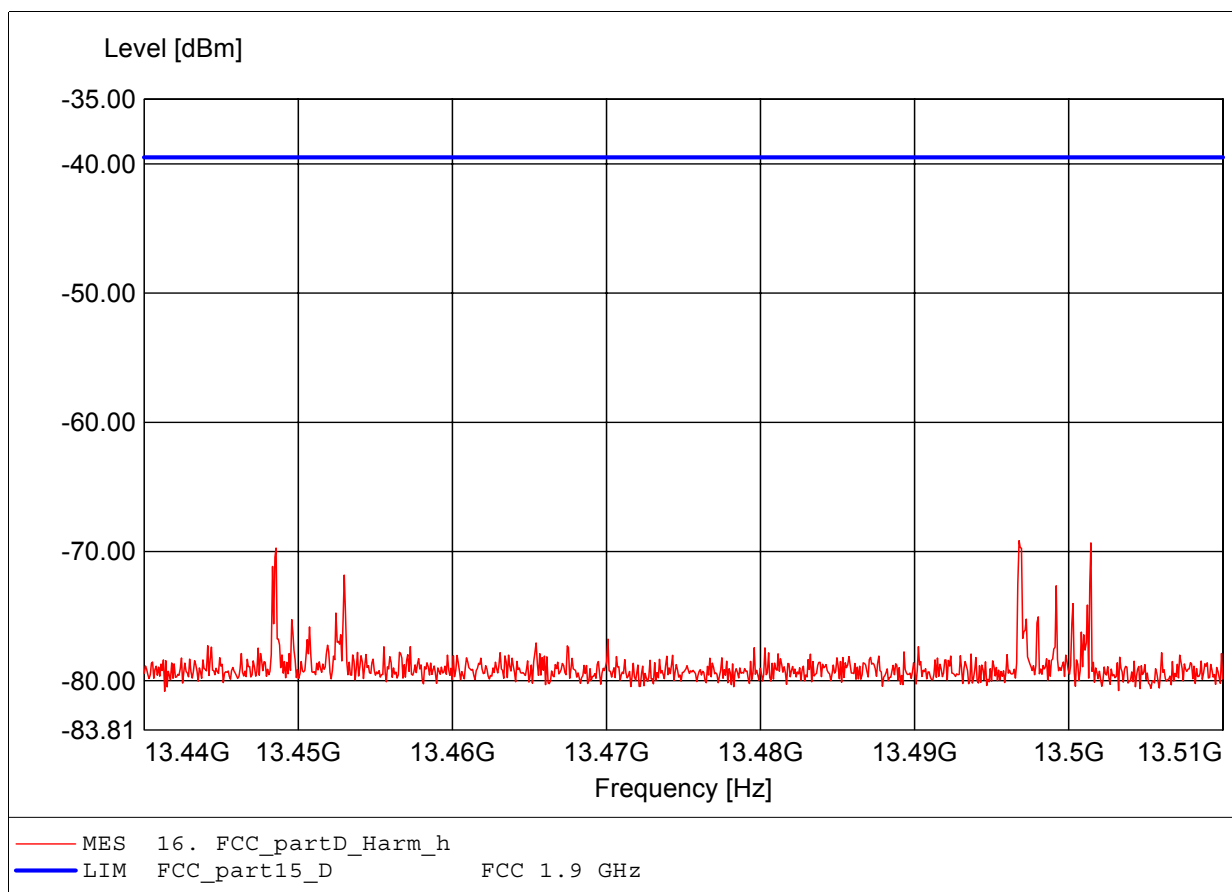

Spurious emissions under normal conditions

FCC PART 15, SUBPART D (ANSI C63.17-1998, Subclause 6.1.6.3)

Approval Holder: POLYCOM KIRK telecom ApS
EUT: DECT RFP
Model: RFP5 1G9 / 1921.536 MHz; 1928.448
Operator: Eurofins Product Service GmbH / Mr. Handrik
Test Conditions: 25°C / Vnom.: 48 V DC
Test Specification: Fully anechoic chamber / mode: Tx
Comment 1: Dist.: 1m, Ant.: HL 025, ampl.
Comment 2: Freq:15.425GHz Pmax:-75.91dBm RBW:10 kHz

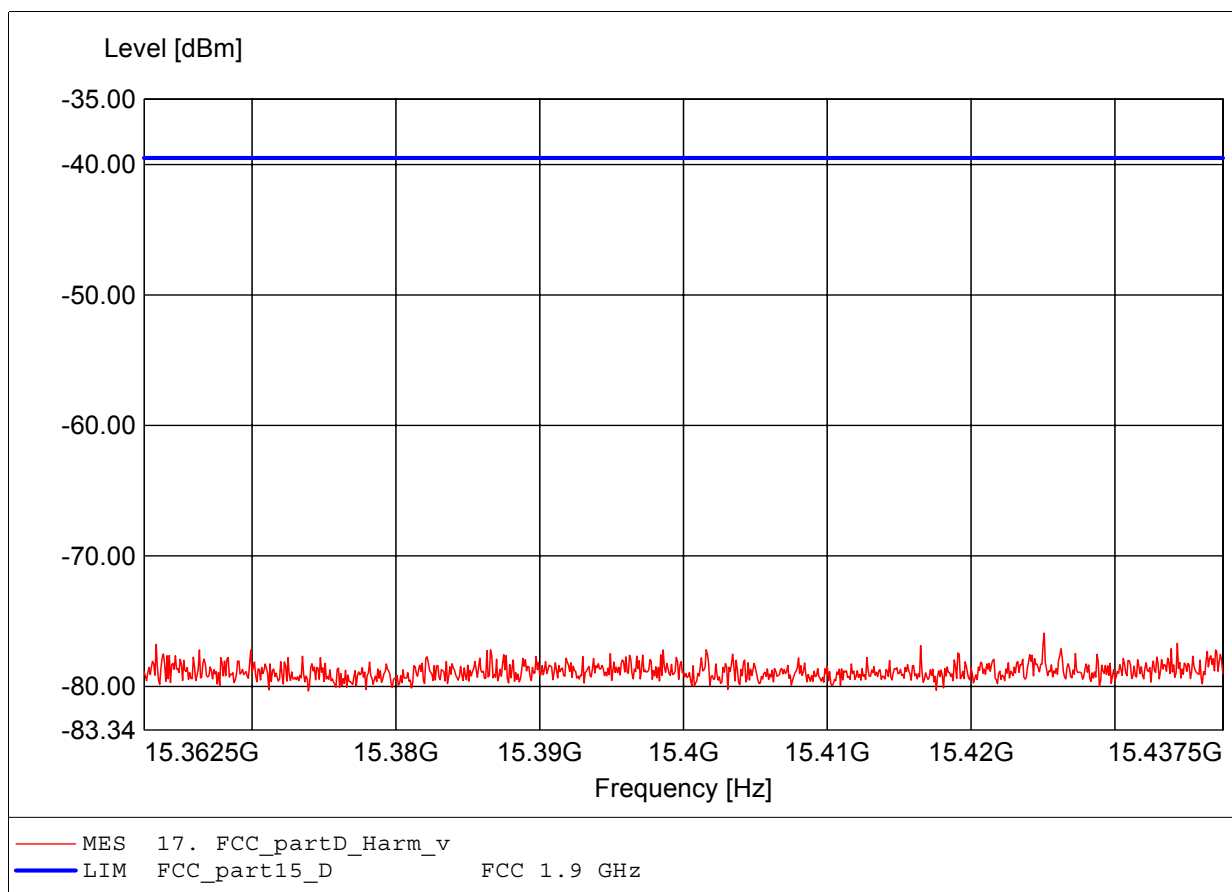

Spurious emissions under normal conditions

FCC PART 15, SUBPART D (ANSI C63.17-1998, Subclause 6.1.6.3)

Approval Holder: POLYCOM KIRK telecom ApS
EUT: DECT RFP
Model: RFP5 1G9 / 1921.536 MHz; 1928.448
Operator: Eurofins Product Service GmbH / Mr. Handrik
Test Conditions: 25°C / Vnom.: 48 V DC
Test Specification: Fully anechoic chamber / mode: Tx
Comment 1: Dist.: 1m, Ant.: HL 025, ampl.
Comment 2: Freq:15.370GHz Pmax:-73.37dBm RBW:10 kHz

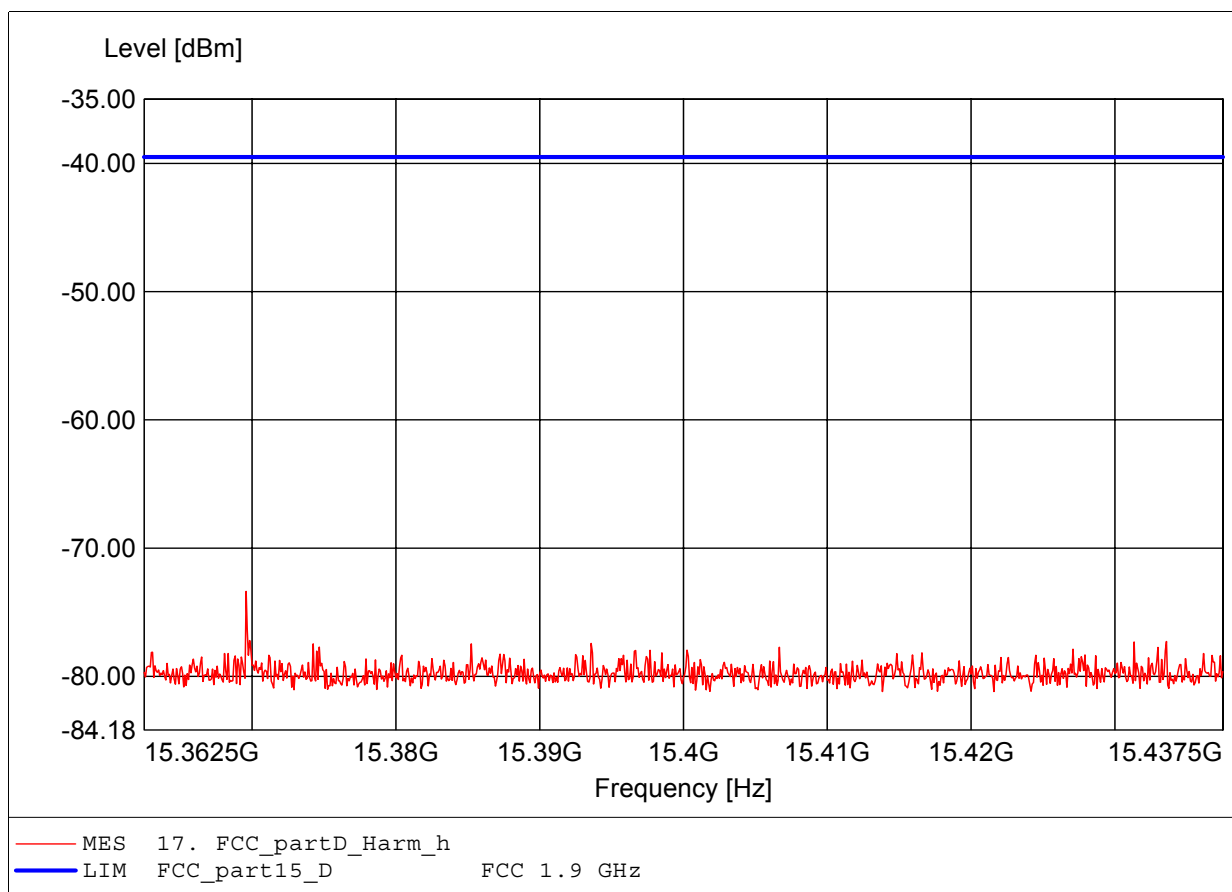

Spurious emissions under normal conditions

FCC PART 15, SUBPART D (ANSI C63.17-1998, Subclause 6.1.6.3)

Approval Holder: POLYCOM KIRK telecom ApS
EUT: DECT RFP
Model: RFP5 1G9 / 1921.536 MHz; 1928.448
Operator: Eurofins Product Service GmbH / Mr. Handrik
Test Conditions: 25°C / Vnom.: 48 V DC
Test Specification: Fully anechoic chamber / mode: Tx
Comment 1: Dist.: 1m, Ant.: HL 025, ampl.
Comment 2: Freq:17.312GHz Pmax:-74.90dBm RBW:10 kHz

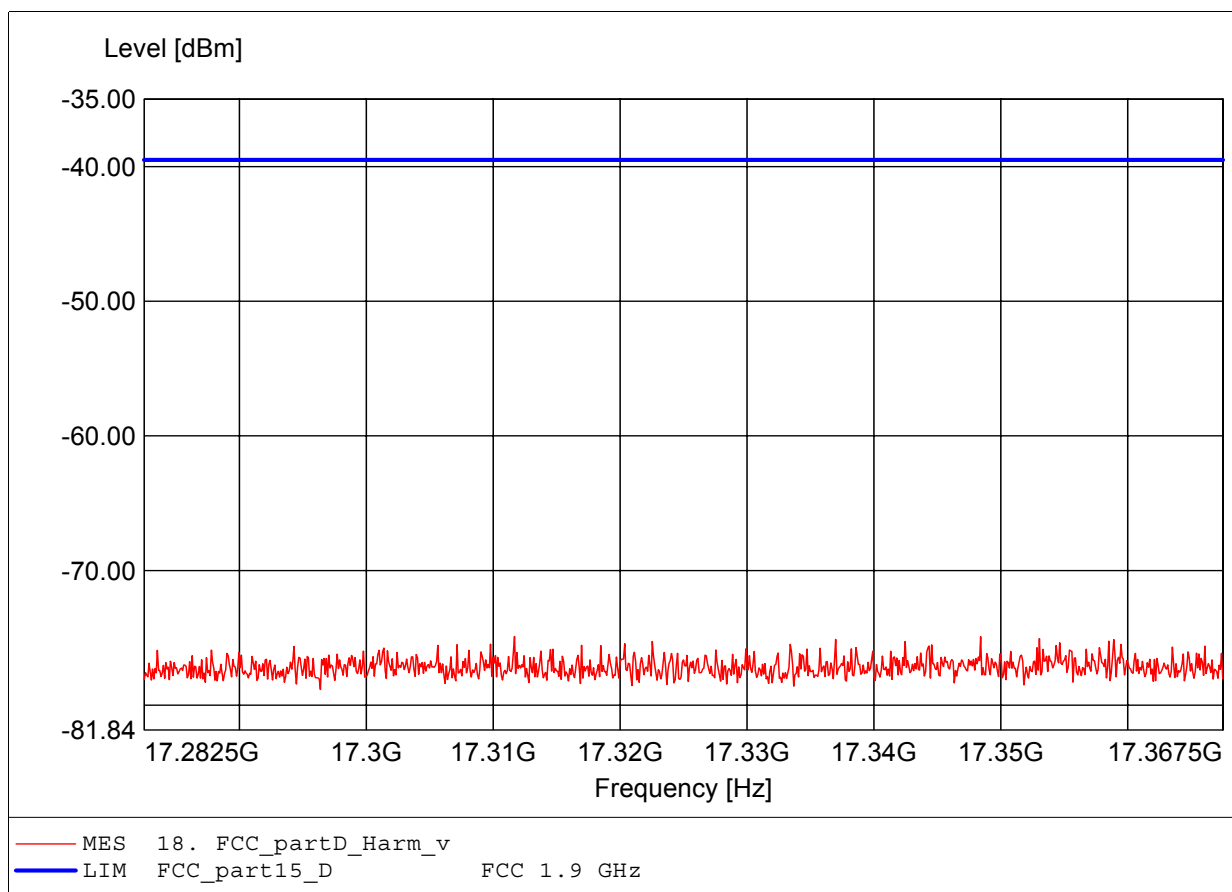

Spurious emissions under normal conditions

FCC PART 15, SUBPART D (ANSI C63.17-1998, Subclause 6.1.6.3)

Approval Holder: POLYCOM KIRK telecom ApS
EUT: DECT RFP
Model: RFP5 1G9 / 1921.536 MHz; 1928.448
Operator: Eurofins Product Service GmbH / Mr. Handrik
Test Conditions: 25°C / Vnom.: 48 V DC
Test Specification: Fully anechoic chamber / mode: Tx
Comment 1: Dist.: 1m, Ant.: HL 025, ampl.
Comment 2: Freq:17.353GHz Pmax:-70.07dBm RBW:10 kHz

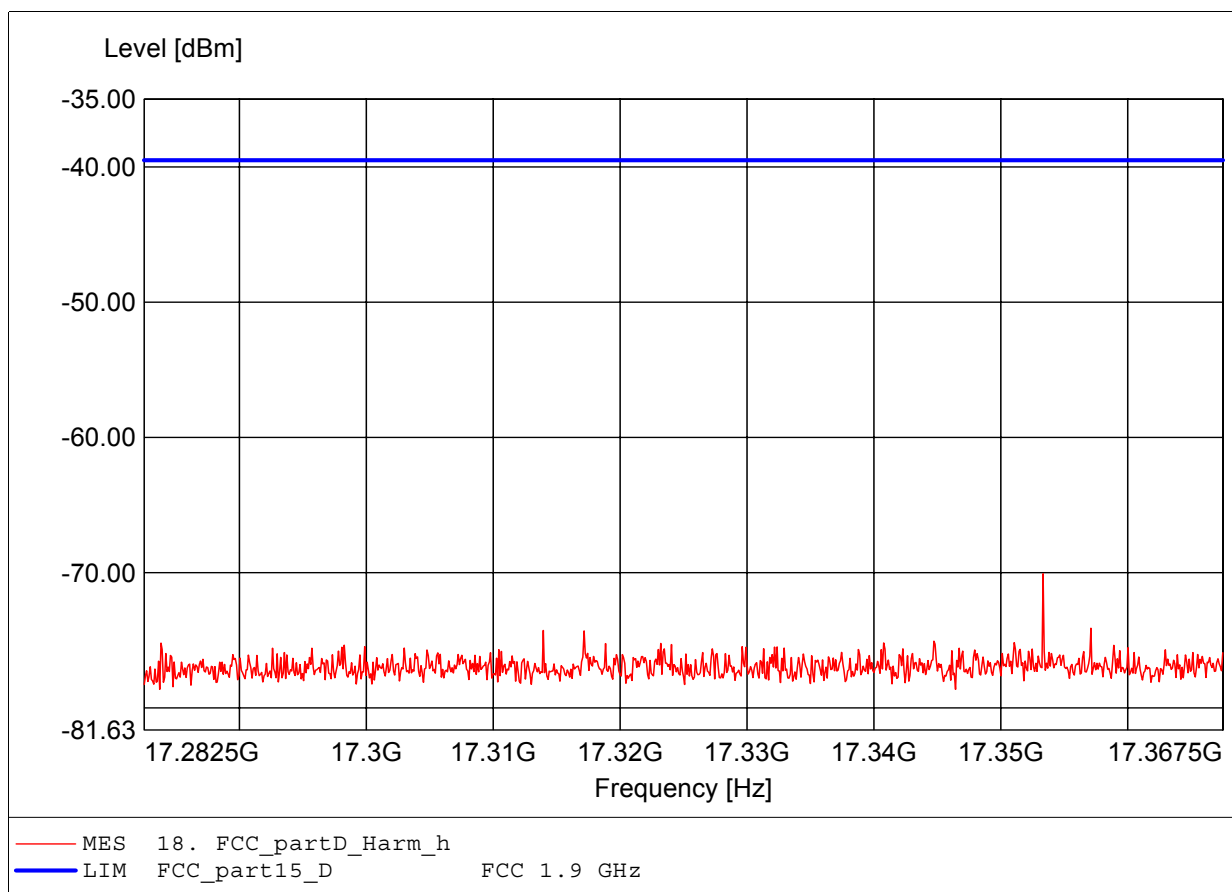

Spurious emissions under normal conditions

FCC PART 15, SUBPART D (ANSI C63.17-1998, Subclause 6.1.6.3)

Approval Holder: POLYCOM KIRK telecom ApS
EUT: DECT RFP
Model: RFP5 1G9 / 1921.536 MHz; 1928.448
Operator: Eurofins Product Service GmbH / Mr. Handrik
Test Conditions: 25°C / Vnom.: 48 V DC
Test Specification: Fully anechoic chamber / mode: Tx
Comment 1: Dist.: 1m, Ant.: HL 025, ampl.
Comment 2: Freq:19.212GHz Pmax:-69.09dBm RBW:10 kHz

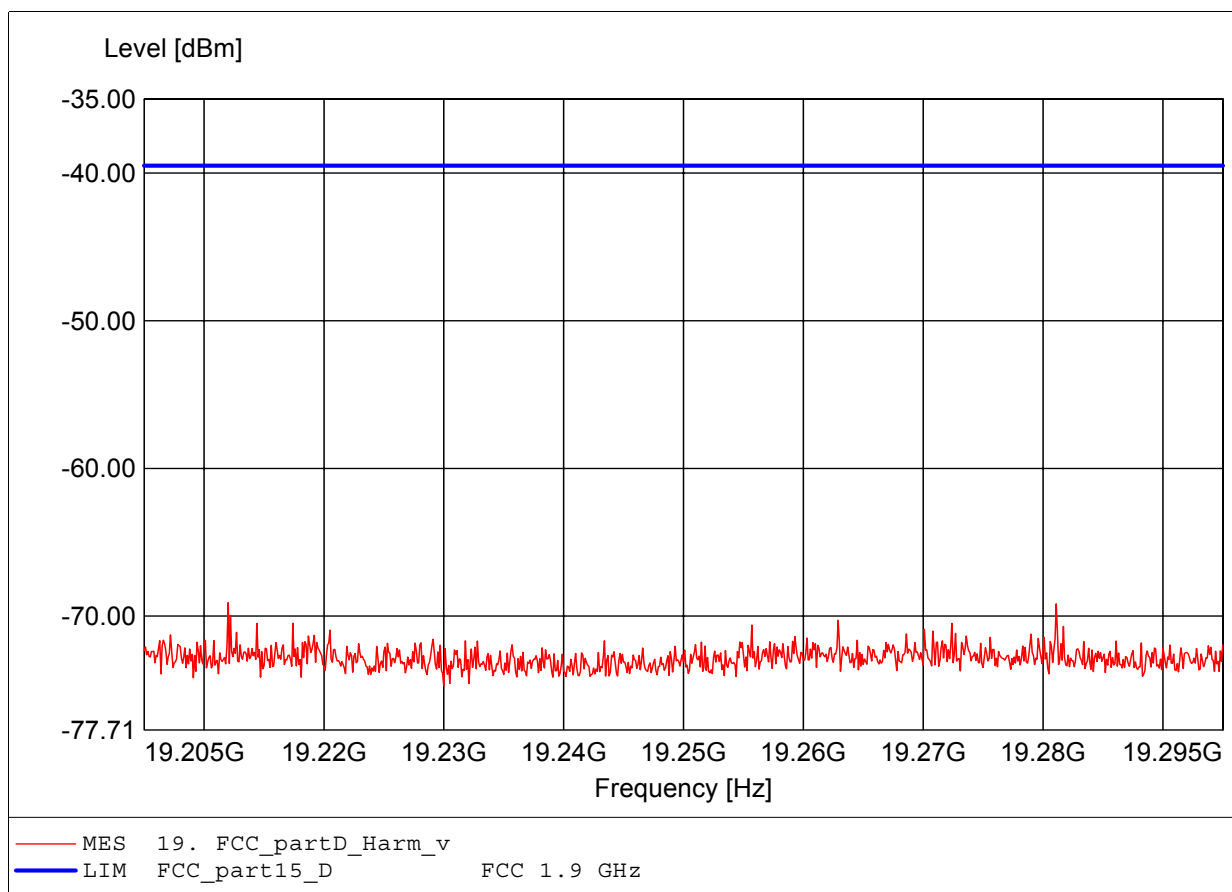

Spurious emissions under normal conditions

FCC PART 15, SUBPART D (ANSI C63.17-1998, Subclause 6.1.6.3)

Approval Holder: POLYCOM KIRK telecom ApS
EUT: DECT RFP
Model: RFP5 1G9 / 1921.536 MHz; 1928.448
Operator: Eurofins Product Service GmbH / Mr. Handrik
Test Conditions: 25°C / Vnom.: 48 V DC
Test Specification: Fully anechoic chamber / mode: Tx
Comment 1: Dist.: 1m, Ant.: HL 025, ampl.
Comment 2: Freq:19.279GHz Pmax:-70.91dBm RBW:10 kHz

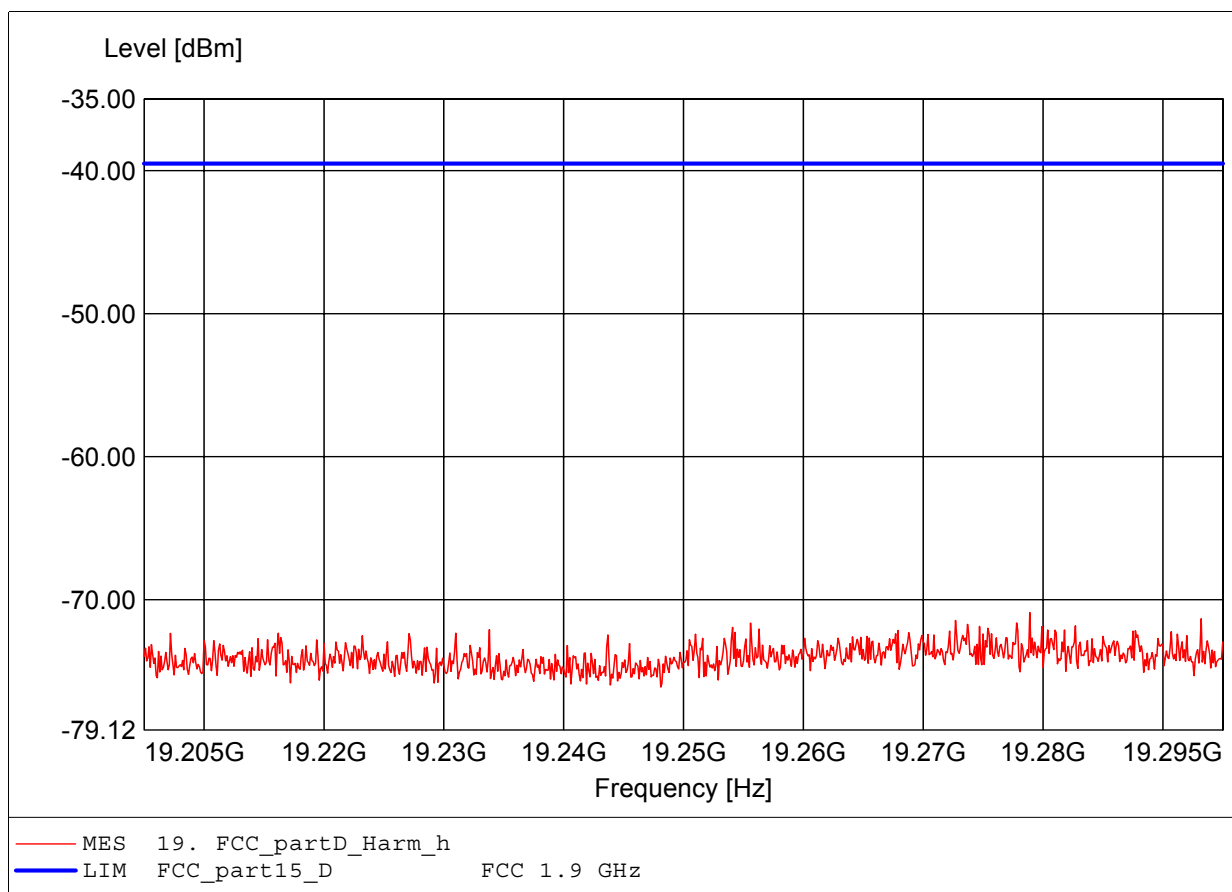

Annex E

Frame period

FCC Part 15.323(e.4) Frame Period and jitter

Testprocedure ANSI 63.17-2006 6.2.3 UCPS

EUT	DECT RFP
Model	RFP5 1G9
Applicant	Polycom Denmark ApS
Temperature	23°C
Test Site / Operator	Eurofins Product Service GmbH
Test Specification	6.2.3 Frame Period and jitter

Width of the time class	0,001900 μ s
Mean	9,999568 ms
Deviation	0,000010
Max-Min	0,047497 μ s
Test result	Verdict = PASS

Histogram

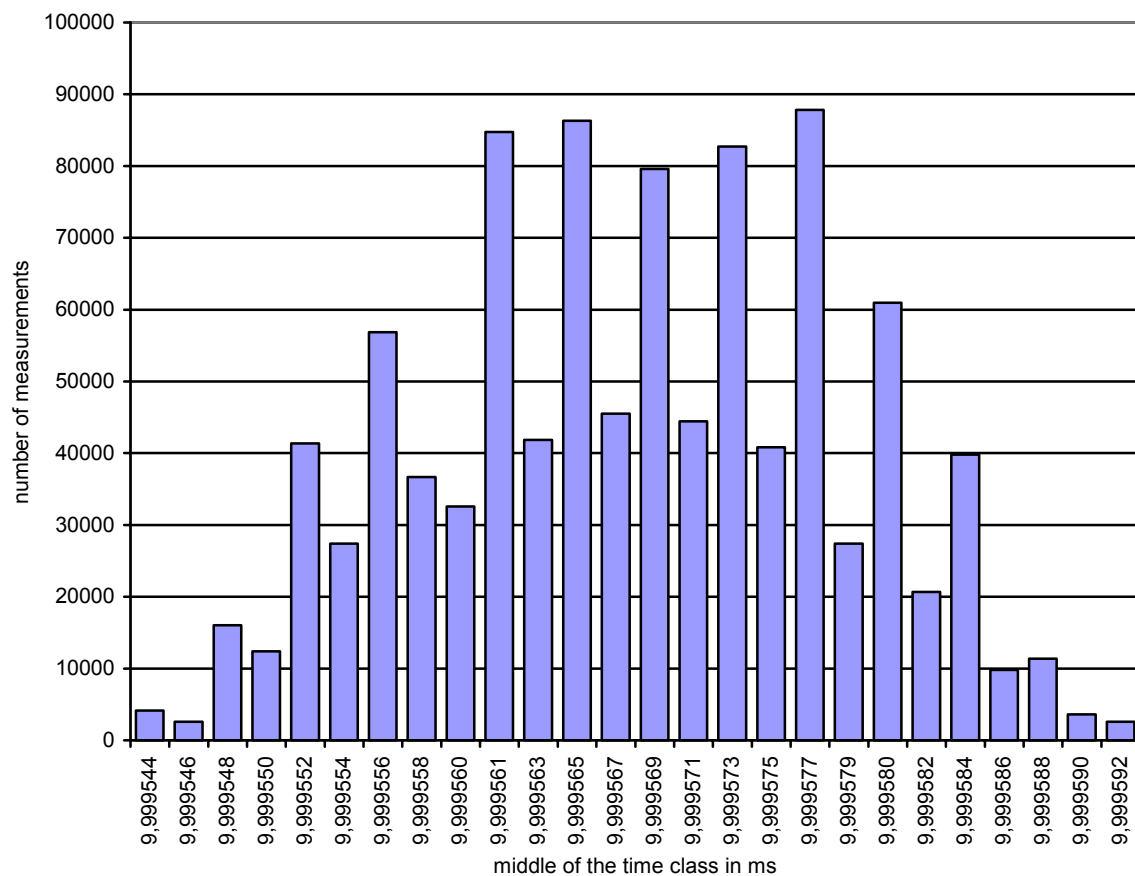

Measurement diagram

FCC Part 15.323(e.1) Frame repetition

Testprocedure ANSI 63.17-2006 6.2.2 UCPS

EUT	DECT RFP
Model	RFP5 1G9
Applicant	Polycom Denmark ApS
Temperature	23°C
Test Site / Operator	Eurofins Product Service GmbH
Test Specification	6.2.2 Frame repetition

Width of the frequency class	0,000002 Hz
Mean	100,000545 Hz
Deviation	0,000012
Stability in ppm	0,371238 ppm
Test result	Verdict = PASS

Histogram

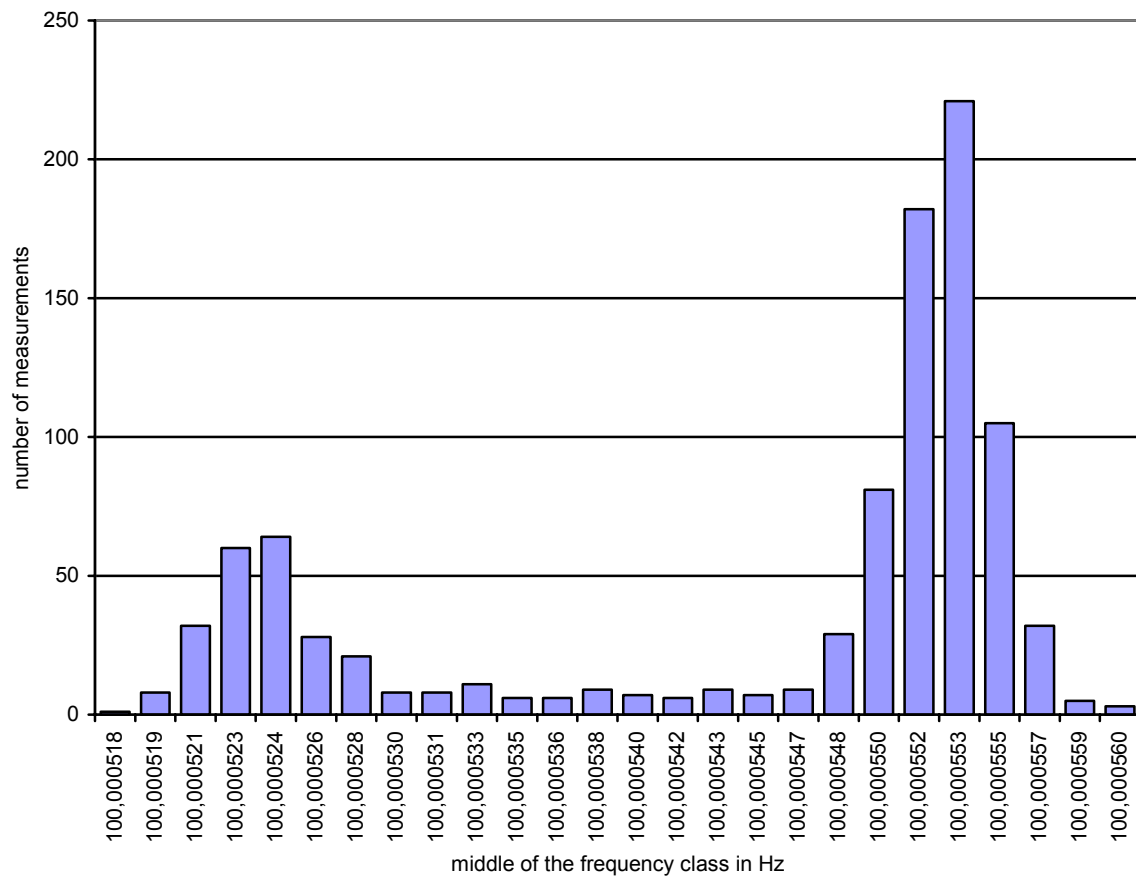

Measurement diagram

Annex F

Frequency stability

FCC Part 15.323(f) Frequency Stability

Testprocedure ANSI 63.17-2006 6.2.1

EUT	DECT RFP
Model	RFP5 1G9
Applicant	Polycm Denmark ApS
Temperature	20 °C
Test Site / Operator	Eurofins Product Service GmbH
Test Specification	6.2.1 Frequency stability

Power supply	Vnom
Frequency of carrier	1924,963968 MHz
Measured mean	1924,965055 MHz
Stability (supply temp)	-0,56 ppm
Result	Verdict = PASS
Stability over time	fmax : 7,18 ppm fmin : 8,14 ppm
Result	Verdict = PASS

Histogram

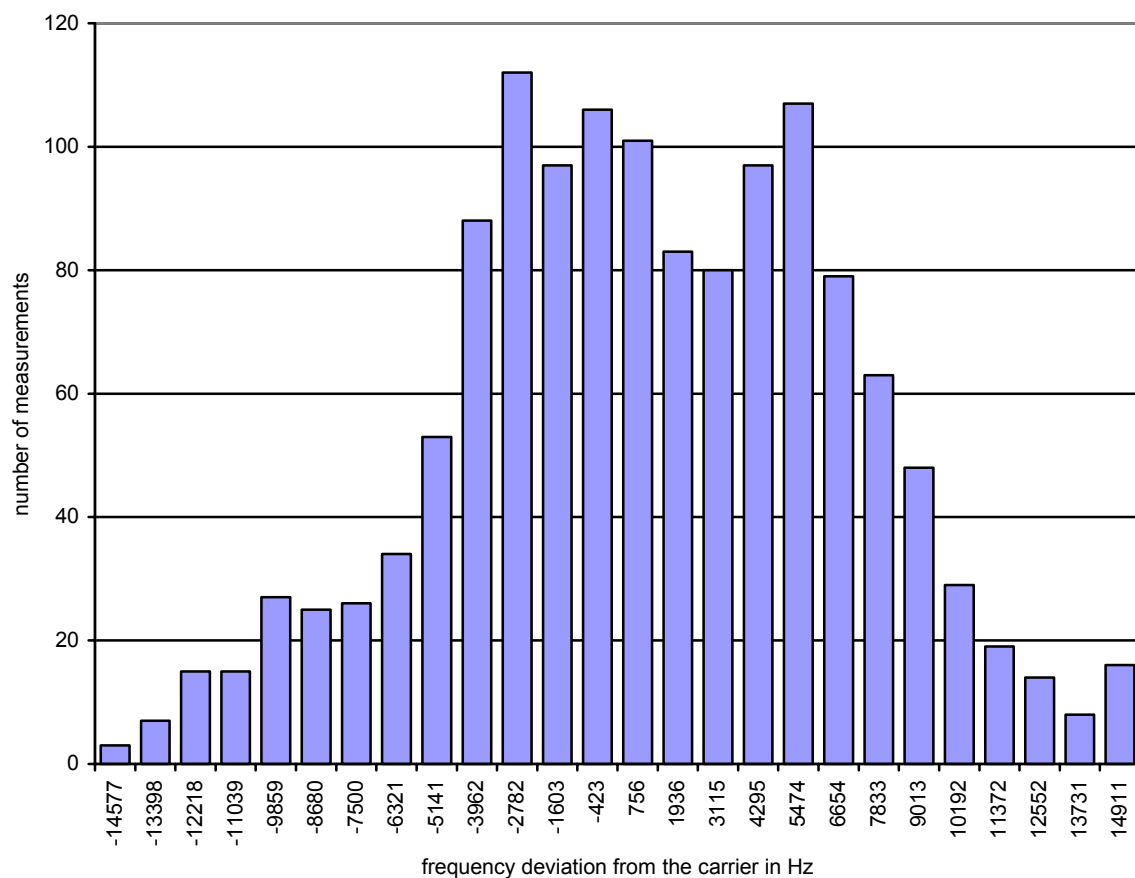

Measurement diagram

Annex G

Receiver spurious emissions

Field Strength under normal conditions

Standards Industry Canada, RSS-GEN

Approval Holder: POLYCOM KIRK telecom ApS
EUT: DECT RFP
Model: RFP5 1G9 / 1924.992 MHz
Operator: Eurofins Product Service GmbH / Mr. Handrik
Test Conditions: 25°C / Vnom.: 48 V DC
Test Specification: according to RSS-Gen
Comment 1: Dist.: 3m, Ant.: HK 116
Comment 2: Freq:62.300MHz Emax:27.67dBuV/m RBW: 100 kHz

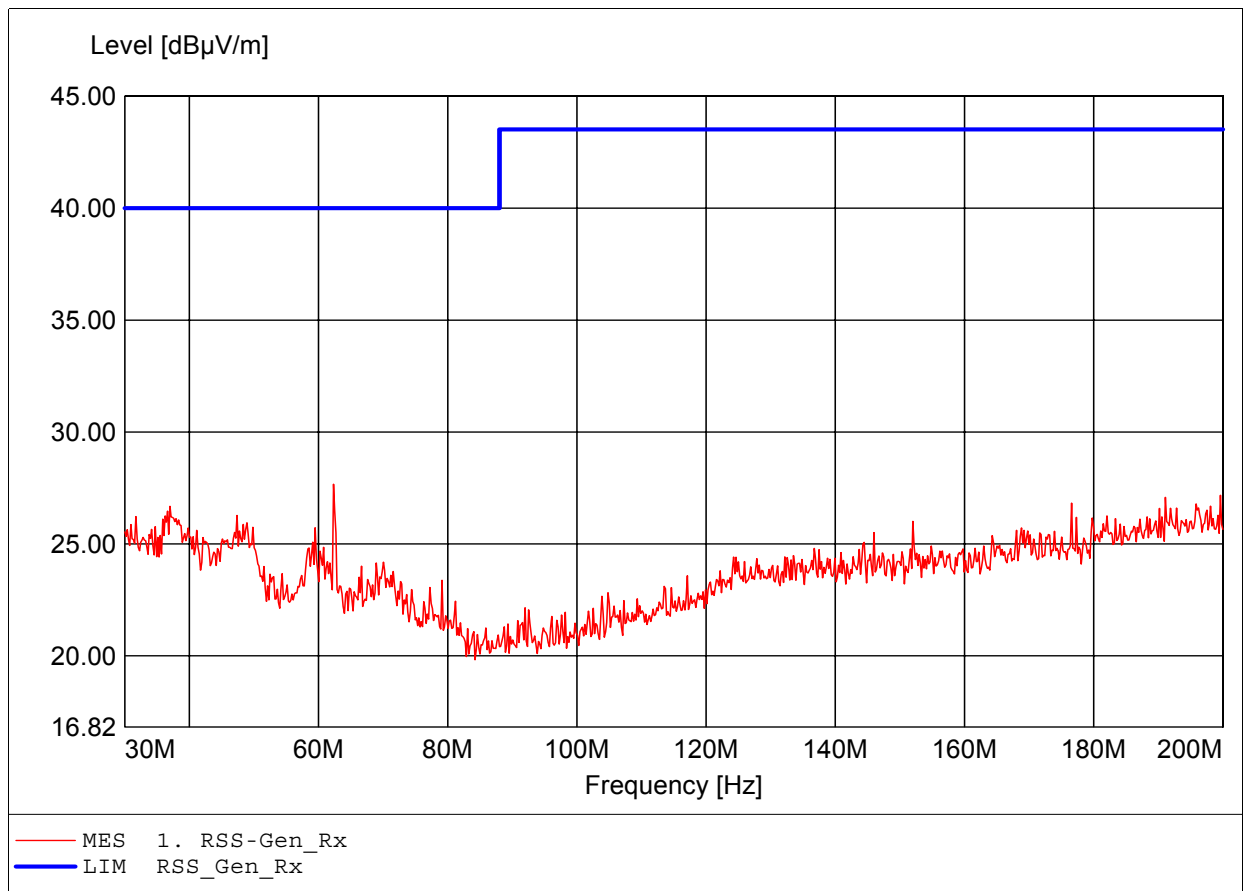

Field Strength under normal conditions

Standards Industry Canada, RSS-GEN

Approval Holder: POLYCOM KIRK telecom ApS
EUT: DECT RFP
Model: RFP5 1G9 / 1924.992 MHz
Operator: Eurofins Product Service GmbH / Mr. Handrik
Test Conditions: 25°C / Vnom.: 48 V DC
Test Specification: according to RSS-Gen
Comment 1: Dist.: 3m, Ant.: HK 116
Comment 2: Freq:198.489MHz Emax:27.17dBµV/m RBW: 100 kHz

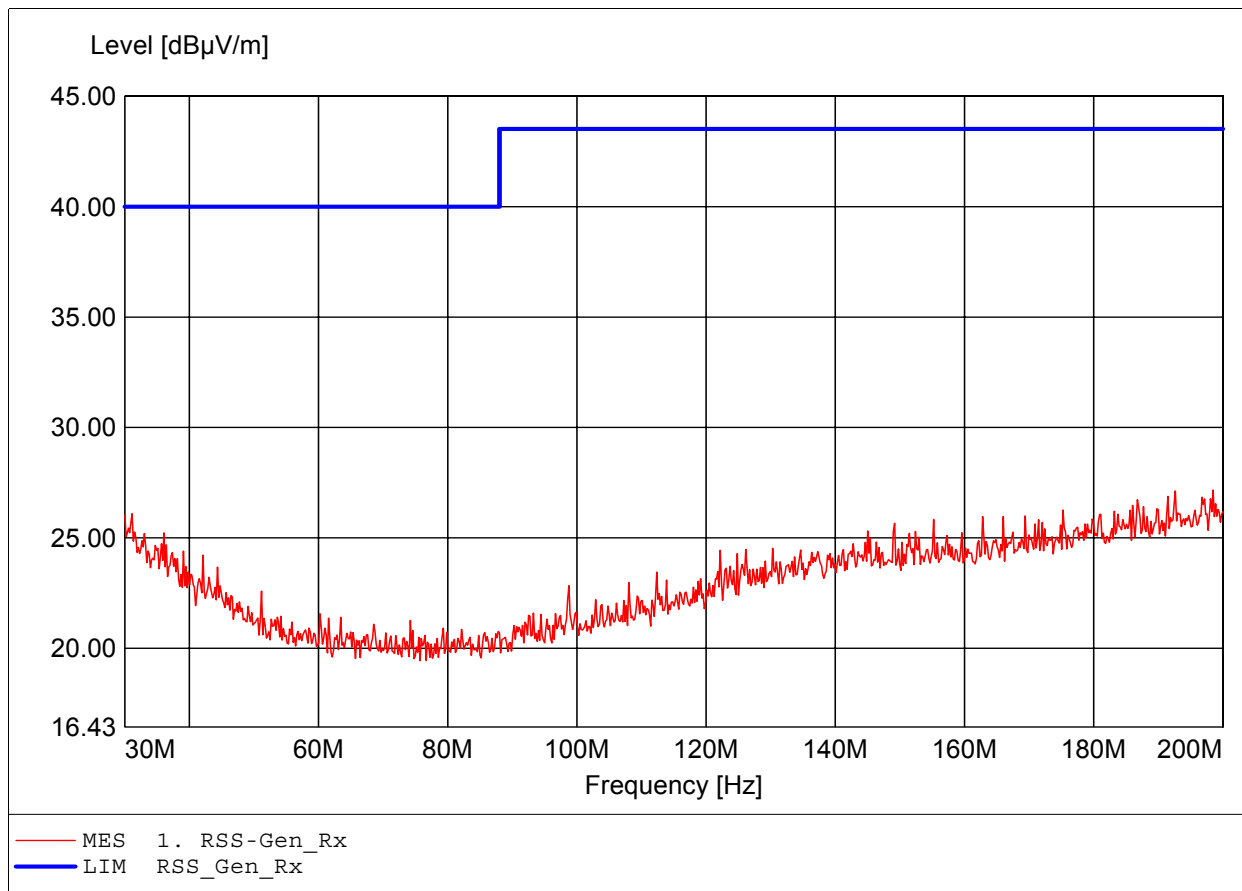

Field Strength under normal conditions

Standards Industry Canada, RSS-GEN

Approval Holder: POLYCOM KIRK telecom ApS
EUT: DECT RFP
Model: RFP5 1G9 / 1924.992 MHz
Operator: Eurofins Product Service GmbH / Mr. Handrik
Test Conditions: 25°C / Vnom.: 48 V DC
Test Specification: according to RSS-Gen
Comment 1: Dist.: 3m, Ant.: HL 223, ampl.
Comment 2: Freq:964.444MHz Emax:21.25dBµV/m RBW: 100 kHz

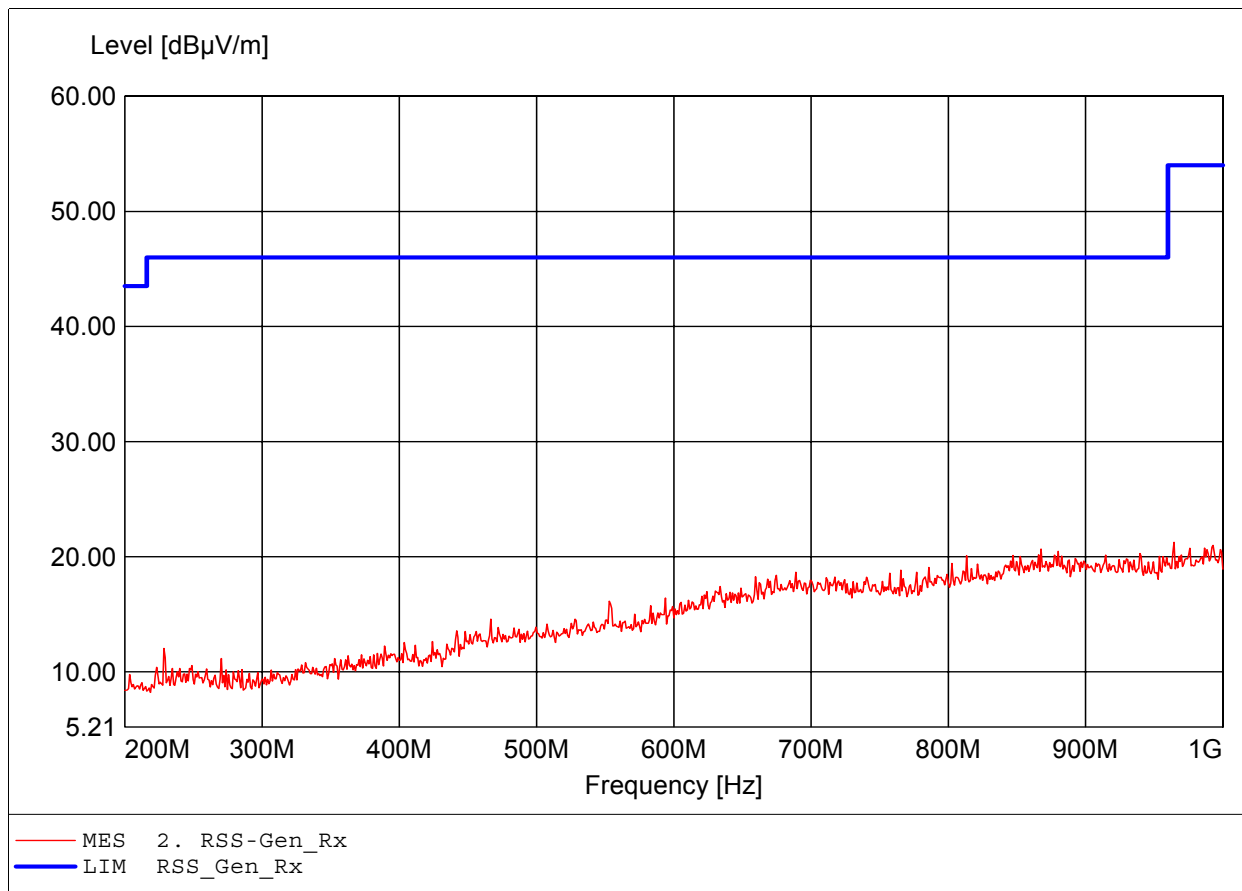

Field Strength under normal conditions

Standards Industry Canada, RSS-GEN

Approval Holder: POLYCOM KIRK telecom ApS
EUT: DECT RFP
Model: RFP5 1G9 / 1924.992 MHz
Operator: Eurofins Product Service GmbH / Mr. Handrik
Test Conditions: 25°C / Vnom.: 48 V DC
Test Specification: according to RSS-Gen
Comment 1: Dist.: 3m, Ant.: HL 223, ampl.
Comment 2: Freq:975.111MHz Emax:21.37dBµV/m RBW: 100 kHz

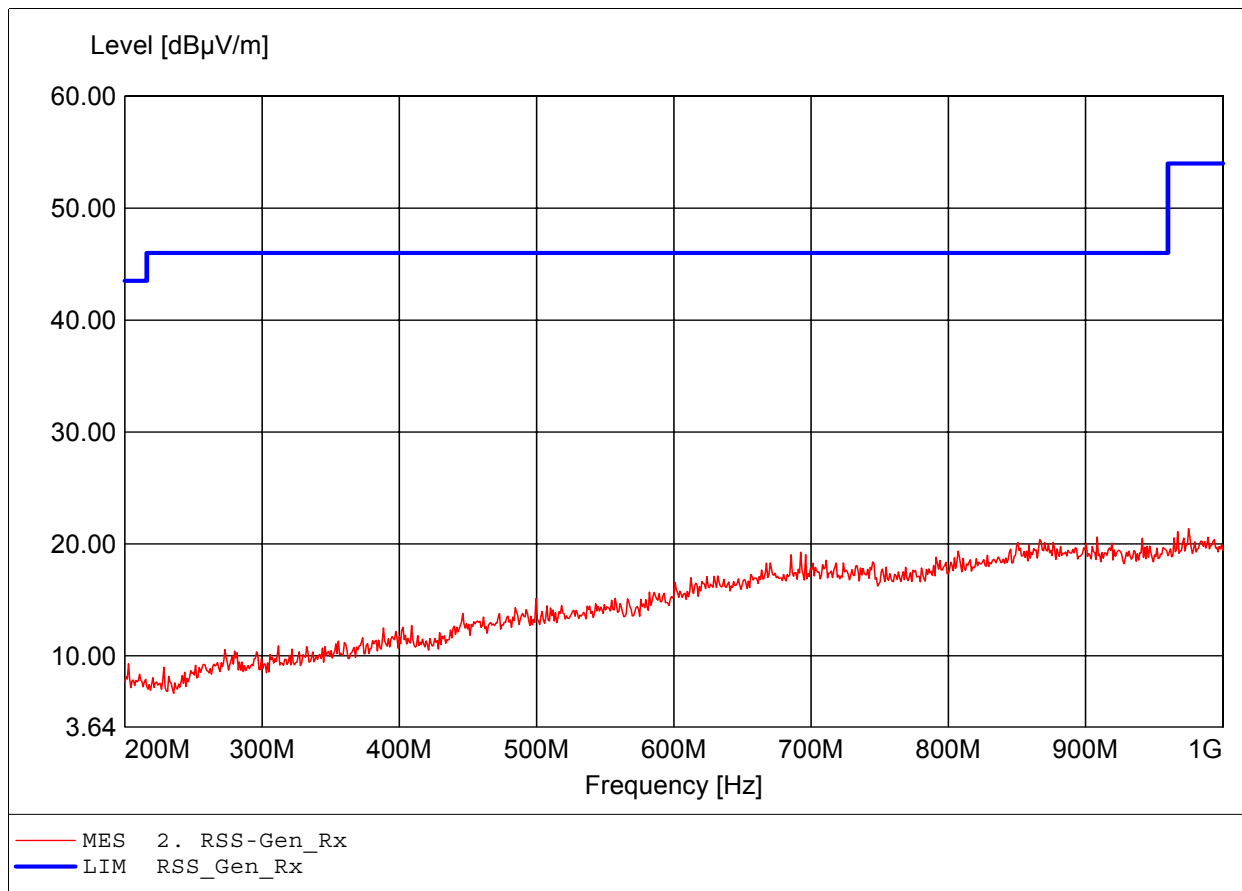

Field Strength under normal conditions

Standards Industry Canada, RSS-GEN

Approval Holder: POLYCOM KIRK telecom ApS
EUT: DECT RFP
Model: RFP5 1G9 / 1924.992 MHz
Operator: Eurofins Product Service GmbH / Mr. Handrik
Test Conditions: 25°C / Vnom.: 48 V DC
Test Specification: according to §15109, peak detector
Comment 1: Dist.: 3m, Ant.: HL025, ampl.
Comment 2: Freq:3.770GHz Emax:43.07dBµV/m RBW: 1 MHz

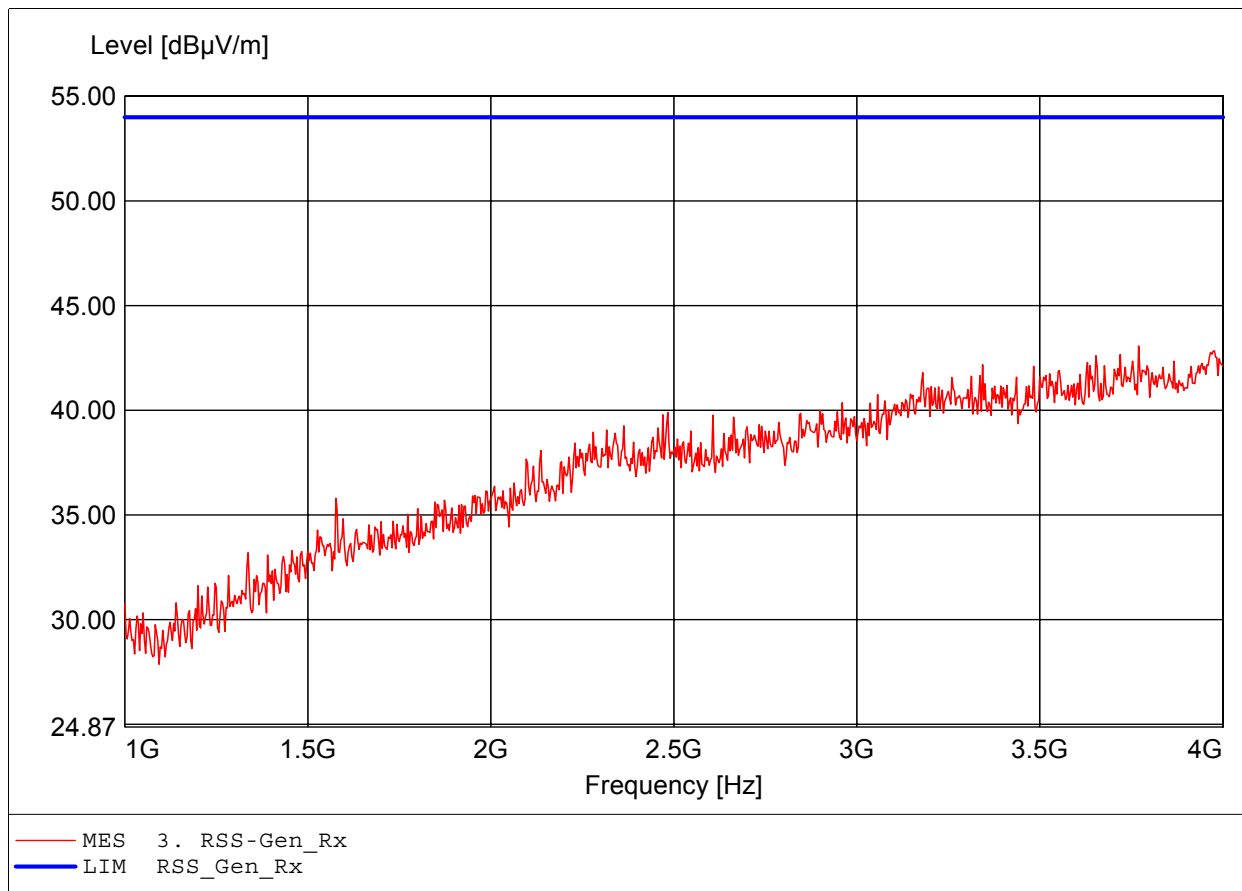

Field Strength under normal conditions

Standards Industry Canada, RSS-GEN

Approval Holder: POLYCOM KIRK telecom ApS
EUT: DECT RFP
Model: RFP5 1G9 / 1924.992 MHz
Operator: Eurofins Product Service GmbH / Mr. Handrik
Test Conditions: 25°C / Vnom.: 48 V DC
Test Specification: according to §15109, peak detector
Comment 1: Dist.: 3m, Ant.: HL025, ampl.
Comment 2: Freq:3.990GHz Emax:42.36dBµV/m RBW: 1 MHz

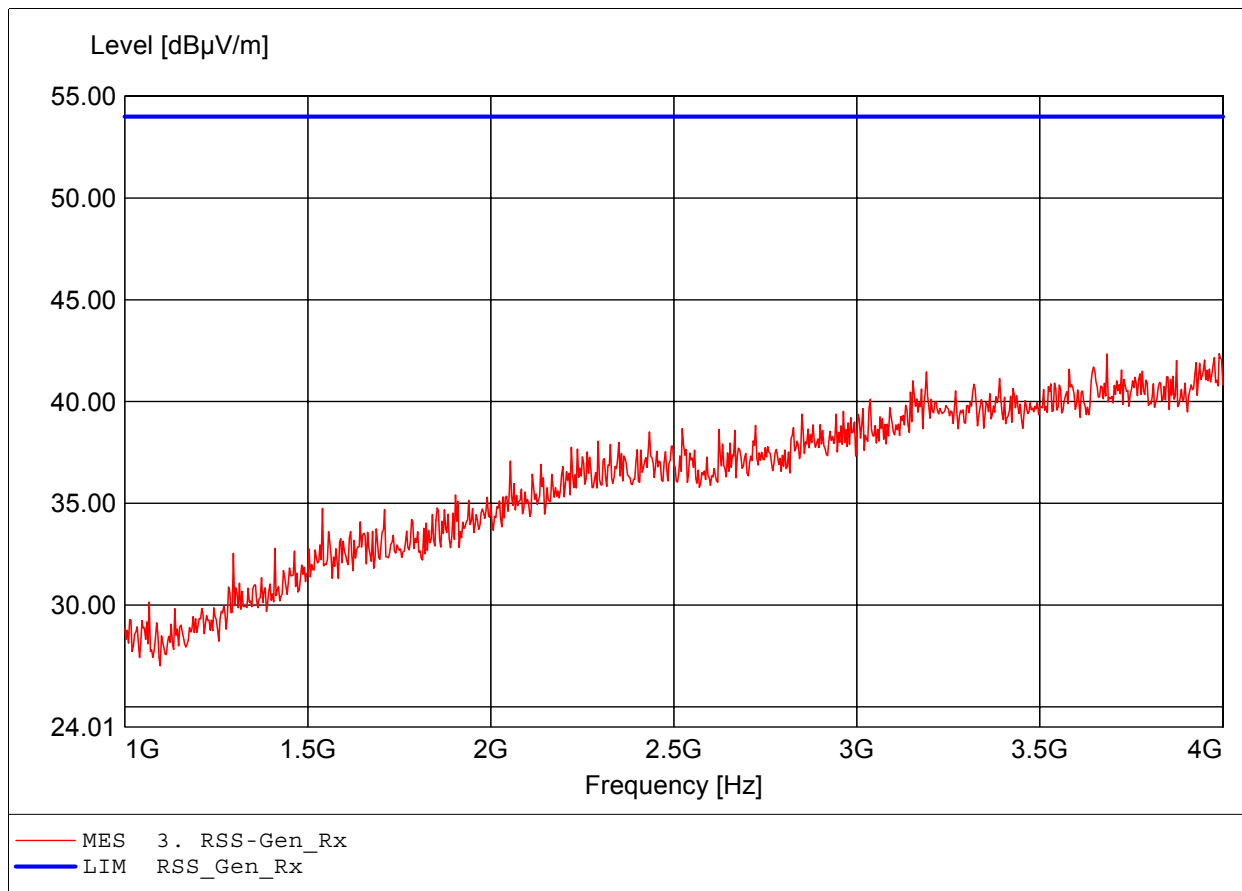

Field Strength under normal conditions

Standards Industry Canada, RSS-GEN

Approval Holder: POLYCOM KIRK telecom ApS
EUT: DECT RFP
Model: RFP5 1G9 / 1924.992 MHz
Operator: Eurofins Product Service GmbH / Mr. Handrik
Test Conditions: 25°C / Vnom.: 48 V DC
Test Specification: according to §15109, peak detector
Comment 1: Dist.: 3m, Ant.: HL025, ampl.
Comment 2: Freq:7.591GHz Emax:43.09dBµV/m RBW: 1 MHz

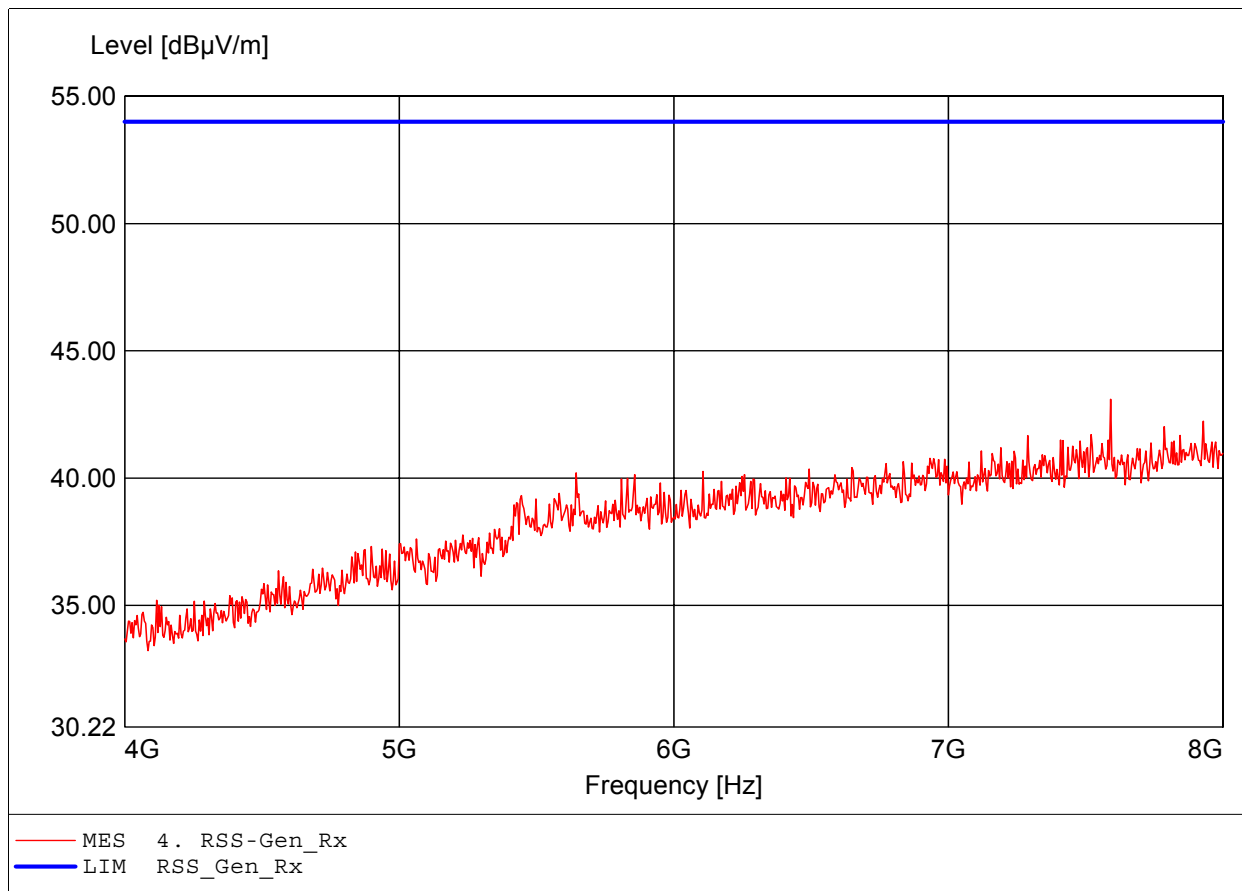

Field Strength under normal conditions

Standards Industry Canada, RSS-GEN

Approval Holder: POLYCOM KIRK telecom ApS
EUT: DECT RFP
Model: RFP5 1G9 / 1924.992 MHz
Operator: Eurofins Product Service GmbH / Mr. Handrik
Test Conditions: 25°C / Vnom.: 48 V DC
Test Specification: according to §15109, peak detector
Comment 1: Dist.: 3m, Ant.: HL025, ampl.
Comment 2: Freq:7.960GHz Emax:42.28dBµV/m RBW: 1 MHz

