

MARS 2.4GHz

Frequency hopping and Dual slot diversity description

History

| | | | |
|---------|-----|--------|--|
| Ver 0.1 | JTP | 980909 | Initial version |
| Ver 0.2 | FM | 990111 | Updated/changed for type approval |
| Ver 0.3 | FM | 990204 | Updated/changed for type approval with new crystal |
| Ver 0.4 | FM | 990730 | Updated/New frequencies /new delay |
| Ver 0.5 | FM | 990909 | Updated/New frequencies |

| | | | | |
|--|--------------------------------|---------------------|-------------|----------------------|
| R T X | Technical Documentation | | | Specification |
| | MARS 2G4 Freq. Hopping | | | |
| File marsalgorithmstypeappr oval.doc | Date 1999-09-09 | Revision 0.4 | Ref. JTP/FM | Page 1 of 9 |

| | |
|---|----------|
| HISTORY | 1 |
| 1. INTRODUCTION | 3 |
| 2. AVOIDANCE METHOD | 3 |
| 2.1 KNOWN HOPPERS | 3 |
| 2.2 MICROWAVE OVENS..... | 3 |
| 2.3 CW INTERFERENCE ON FIXED RF CARRIERS | 3 |
| 2.4 OTHER HOPPERS..... | 3 |
| 2.5 IMPROVE RANGE / MULTI-PATH PERFORMANCE..... | 3 |
| 3. ADAPTATION TO 2.4GHZ ISM BAND | 4 |
| 3.1 FRAME FORMAT: | 4 |
| 3.2 BURST FORMAT:..... | 5 |
| 3.2.1 Sync-field | 5 |
| 3.2.2 A-field | 5 |
| 3.2.3 B-field | 6 |
| 3.2.4 XZ-field..... | 7 |
| 3.3 FREQUENCY HOPPING ALGORITHM..... | 7 |
| 3.3.1 Excluded carriers..... | 7 |
| 3.3.2 Hopping tables..... | 8 |
| 3.3.3 Example | 8 |
| 3.4 PP SYNCHRONIZATION PROCEDURE | 8 |
| 3.5 DUAL SLOT DIVERSITY | 9 |
| 3.6 POWER AMPLIFIER ACTIVATION | 9 |
| 3.6.1 External connection..... | 9 |
| 3.6.2 Internal connection..... | 9 |

| | | | | |
|--|--------------------------------|---------------------|-------------|----------------------|
| R T X | Technical Documentation | | | |
| | MARS 2G4 Freq. Hopping | | | Specification |
| File marsalgorithmstypeappr oval.doc | Date 1999-09-09 | Revision 0.4 | Ref. JTP/FM | Page 2 of 9 |

1. Introduction

The Mars system is based on DECT the ETSI standard ETS-300-175-1 to ETS-300-175-9. The Mars system is improved by implementing extra features to combat the interference at 2.4 GHz.

The frequency hopping method for 2.4 GHz ISM band has to provide optimal performance and connection quality in environment with 5 different types of interference:

1. Other interference of MARS-type, known hopping algorithm and avoidance method (synchronized/unsynchronized).
2. Microwave ovens, sweeping the most of the band and running on 60Hz mains supply.
3. Interference on fixed RF carrier, CW interference. Direct sequence CDMA is also detected as this type of interference.
4. Other hoppers using the ISM band, with unknown hopping algorithm, example: Wireless LAN based on IEEE802.11, etc.
5. "Range / multi-path propagation"

The frame format is based on DECT, but modified from 24 timeslots to 18 or 20 timeslots and 79/23/27/35 possible RF carriers. Frequency hopping is implemented on a frame by frame basis. The system is implemented with encryption based on DECT.

2. Avoidance method

2.1 Known hoppers

Use 79 RF channels. Re-map though hopping table. Part of RFPI/RPN defines which hopping sequence to use. Bearer hand-over: change of slot-position and hopping index. Avoid modulo 16 sequences (= DECT sequences).

Different connection/bearer should use different hopping index.

2.2 Microwave ovens

Use dual slot diversity. Transmission of same B-field content in two slots on different carrier. Normal one frame delay extended to two frames delay in each direction in order to ensure seamless selection of best received burst. Total extra round-trip delay is two extra frames.

2.3 CW interference on fixed RF carriers

Exclude discrete RF carriers and adaptive use of dual-slot diversity.

2.4 Other hoppers

Appears like random interference. Adaptive usage of dual-slot diversity.

2.5 Improve range / multi-path performance

Use prolonged preamble. In the base the frequency hopping sequence must be: RX – TX

| | | | | |
|--|--------------------------------|---------------------|-------------|----------------------|
| R T X | Technical Documentation | | | |
| | MARS 2G4 Freq. Hopping | | | Specification |
| File marsalgorithmstypeappr oval.doc | Date 1999-09-09 | Revision 0.4 | Ref. JTP/FM | Page 3 of 9 |

3. Adaptation to 2.4GHz ISM band

3.1 Frame format:

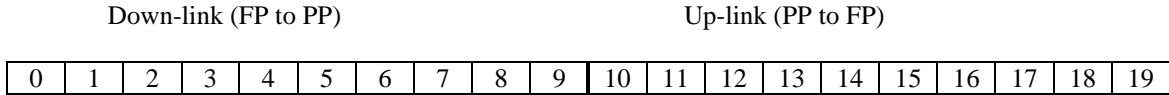

length 11.15 ms
or

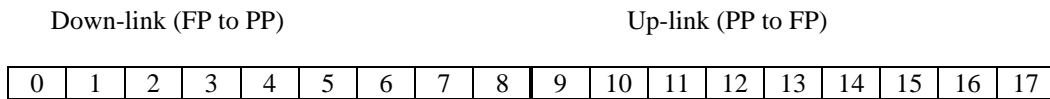

length 10 ms

3.1.1 Crystal frequency 9.302131 MHz

Symbol rate: 1.033570 Mbit/sec.
 Frame length: 20 timeslots, same as 11.1458 msec.
 Frame frequency: 89.72 Hz
 Number of symbols for frame: 11520
 Number of symbols per slot: 576 (440 in burst and 136 in guard space)

3.1.2 Crystal frequency 9.216000 MHz

Symbol rate: 1.024 Mbit/sec.
 Frame length: 18 timeslots with 568 bits + 18 bits, same as 10 msec.
 Frame frequency: 100 Hz
 Number of symbols for frame: 10240
 Number of symbols per slot: 568 (440 in burst and 128 in guard space)

For the remaining part of the document the 10 slots are replaced with 9.

Frequency hopping frame begins from slot 10. Slots are used in pairs for duplex bearers (0,10), (1,11), etc. The same RF carrier used in up-link direction of a slot-pair in frame N is used in down-link direction in frame N+1.

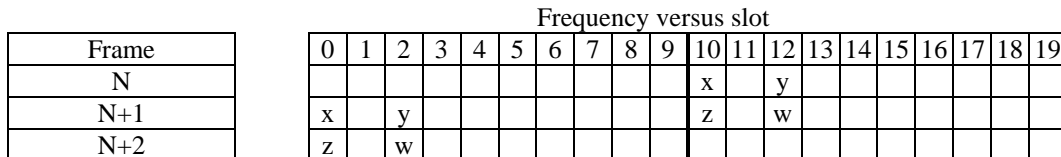

| | | | | |
|---|---|---------------------|-------------|----------------------|
| | Technical Documentation MARS 2G4 Freq. Hopping | | | Specification |
| File marsalgorithmstypeappr oval.doc | Date 1999-09-09 | Revision 0.4 | Ref. JTP/FM | Page 4 of 9 |

3.2 Burst format:

| | | | | |
|------------|---------|---------|----|-------------|
| Sync field | A field | B field | XZ | Guard space |
|------------|---------|---------|----|-------------|

3.2.1 Sync-field

Length: up to 48 symbols consisting of

- Possibly Prolonged preamble: 16 bit data
- Preamble for bit-synchronization: 16 bit data
- Frame synchronization word: FP: E98Ah
PP: 1675h

Pattern for transmission from FP:
1010 0101 1010 1010 1110 1001 1000 1010

Pattern for transmission from PP:
0011 0011 0011 0011 0101 1010 0101 0101 0001 0110 0111 0101

3.2.2 A-field

Total length 64 symbols
Header: 8 bit
Tail: 40 bit
CRC: 16 bit

3.2.2.1 T-MUX:

- NT: RFPI is normally broadcast 7 out of every 8 frames.
- QT: Static system information
- PT: Broadcast, paging
- MT: MAC layer control
- CT: Connection oriented higher layer signaling

3.2.2.2 Derive hopping SeQuenceCode (SQC) from RFPI

In order to distribute usage of different hopping sequences, the actual used sequence is derived from the FP identity, RFPI. The RFPI is normally broadcast 7 out of every 8 frames which then allows immediate recognition of hopping sequence by the PP during the initial synchronization.

The RFPI consists of 40 bits (5 bytes):

| | | | | | |
|-------|--|--|--|--|-----|
| E ARC | | | | | RPN |
| a8 | | | | | a47 |

If the ARC equal 000 the RPN has three bits in length and is a Park type A, otherwise the RPN has a length of eight and is.

| | | | | | |
|-------|--|--|--|--|-----|
| E ARC | | | | | RPN |
| a8 | | | | | a47 |

| | | | | |
|--|---|---------------------|-------------|----------------------|
| R T X | Technical Documentation MARS 2G4 Freq. Hopping | | | Specification |
| File marsalgorithmstypeappr oval.doc | Date 1999-09-09 | Revision 0.4 | Ref. JTP/FM | Page 5 of 9 |

This document and the information contained is property of RTX Telecom A/S, Denmark. Unauthorized copying is not allowed. The information in this document is believed to be correct at the time of writing. RTX Telecom A/S reserves the right at any time to change said content, circuitry and specifications.

Two different positions of the SeQuenceCode (SQC) inside the RFPI is defined, in order to flexibility in deciding usage of same or different hopping sequence in multi-cell systems.

Option 0:

Park type A (residential):

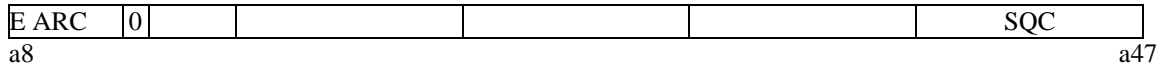

The SQC is located from bit a42 to a47.

Park type different from A:

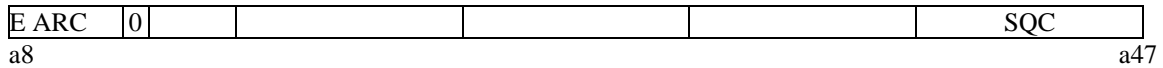

The SQC is located from bit a42 to a47.

Option 1:

Park type A (residential):

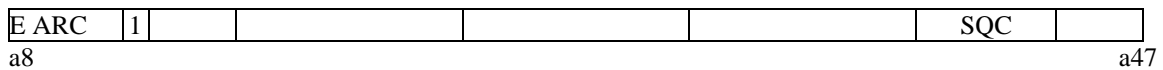

The SQC is located from bit a40 to a44.

Park type different from A:

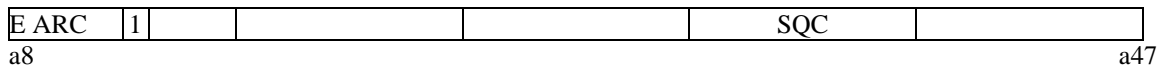

The SQC is located from bit a34 to a39.

3.2.2.3 Excluding fixed carriers.

List of excluded RF carriers or parts hereof is broadcast using paging (reserved code 3). Two different methods are defined:

- PT₃ (1): *EXCN0*[7], *EXCN1*[7], *EXCN2*[7], *EXCN3*[7] (28 bits used)
- PT₃ (2): *ExcpPattern0*[32] (32 bits used)
- PT₃ (3): *ExcpPattern1*[32] (32 bits used)
- PT₃ (4): *ExcpPattern2*[15] (15 bits used)

EXCN_x is the carrier number of an excluded RF carrier. Up to four individual carriers may be excluded using this method.

ExcpPattern_x describes a complete pattern of excluded RF carriers.

3.2.3 B-field

Format and usage of B-field is similar to DECT. 320 bits of ADPCM data.

| | | | | |
|--|--------------------------------|---------------------|-------------|----------------------|
| R T X | Technical Documentation | | | |
| | MARS 2G4 Freq. Hopping | | | Specification |
| File marsalgorithmstypeappr oval.doc | Date 1999-09-09 | Revision 0.4 | Ref. JTP/FM | Page 6 of 9 |

3.2.4 XZ-field

Format and usage of XZ-field is similar to DECT. X-field is a 4-bit CRC on the B-field content. Z-field is a copy of the X field and is used to detect sliding collision.

3.3 Frequency hopping algorithm

The number of used frequencies (NUF) in hopping algorithm is:

| | |
|----------------|----|
| North America | 79 |
| Most of Europe | 79 |
| Japan | 23 |
| Spain | 27 |
| France | 35 |

In FP and PP exists a PrimaryHoppingIndexNumber (PHIN). This number is incremented modulo NUF in the end of the normal downlink half-frame. It is broadcast in Q0 message instead of PSCN.

To a simplex or an established duplex bearer is assigned a HoppingIndexOffset (HIO), which is analogue to the used RF carrier in a FDMA system. This value is broadcast in place of CN in Q0 message. In the FP in all unused slots in up-link direction the receiver is scanning with HIO=0. The receiver scanning doesn't exclude RF-carriers.

Different FPs use different hopping sequences. The different sequences are derived from the hopping table by adding an offset, SequenceCode (SQC). This is a value in the range 0 – (NUF-1), extracted from the FP identity (RFPI).

A hopping table maps an index I to a carrier number: $CN = f(I)$

The physical RF carrier is calculated by the formula:

$$CN = (f ((PHIN+HIO) \text{ mod } NUF) + SQC) \text{ mod } NUF$$

3.3.1 Excluded carriers

Excluded carriers (exceptions) are fixed carriers that constantly are interfered by CW RF-carrier. The decision for excluding a RF carrier, are based on:

- RSSI monitor during scanning in the FP.
- Bearer quality in FP correlated to specific RF-carriers.
- Bearer quality detected in PP and reported using Q1 in MAC-header.

When exception carriers are included the complete algorithm is:

```

I = (PHIN+HIO) mod NUF
CN = ( f (I) + SQC ) mod NUF
While CN in ExclusionList
{
  I = I + ((FrameNumber16 / NUF) mod (NUF-1)) +1
  CN = ( f (I) + SQC ) mod NUF
}
    
```

FrameNumber16 equals 1

| | | | | |
|--|---|---------------------|-------------|----------------------|
| R T X | Technical Documentation MARS 2G4 Freq. Hopping | | | Specification |
| File marsalgorithmstypeappr oval.doc | Date 1999-09-09 | Revision 0.4 | Ref. JTP/FM | Page 7 of 9 |

3.3.2 Hopping tables

Three different hopping tables are defined.

3.3.2.1 Hopping sequence for North America and most of Europe

For 9.302131 MHz crystal the frequencies are derived as:

Frequency: $2400.983 + CN * 1.033570$ MHz

For 9.216000 MHz crystal the frequencies are derived as:

Frequency: $2401.280 + CN * 1.024000$ MHz

| i | f(I) | i | f(i) | I | f(i) | i | f(i) | i | f(f) | i | f(i) | i | f(i) | i | f(i) |
|---|------|----|------|----|------|----|------|----|------|----|------|----|------|----|------|
| 0 | 0 | 10 | 76 | 20 | 18 | 30 | 34 | 40 | 14 | 50 | 20 | 60 | 48 | 70 | 55 |
| 1 | 23 | 11 | 29 | 21 | 11 | 31 | 66 | 41 | 57 | 51 | 73 | 61 | 15 | 71 | 35 |
| 2 | 62 | 12 | 59 | 22 | 36 | 32 | 7 | 42 | 41 | 52 | 64 | 62 | 5 | 72 | 53 |
| 3 | 8 | 13 | 22 | 23 | 72 | 33 | 68 | 43 | 74 | 53 | 39 | 63 | 17 | 73 | 24 |
| 4 | 43 | 14 | 52 | 24 | 54 | 34 | 75 | 44 | 32 | 54 | 13 | 64 | 6 | 74 | 44 |
| 5 | 16 | 15 | 63 | 25 | 69 | 35 | 4 | 45 | 70 | 55 | 33 | 65 | 67 | 75 | 51 |
| 6 | 71 | 16 | 26 | 26 | 21 | 36 | 60 | 46 | 9 | 56 | 65 | 66 | 49 | 76 | 38 |
| 7 | 47 | 17 | 77 | 27 | 3 | 37 | 27 | 47 | 58 | 57 | 50 | 67 | 40 | 77 | 30 |
| 8 | 19 | 18 | 31 | 28 | 37 | 38 | 12 | 48 | 78 | 58 | 56 | 68 | 1 | 78 | 46 |
| 9 | 61 | 19 | 2 | 29 | 10 | 39 | 25 | 49 | 45 | 59 | 42 | 69 | 28 | | |

3.3.3 Example.

This example shows receive and transmit frequencies in a number of consecutive frames. The example is seen from the FP side with two simultaneous connections. Transmission is indicated in bold.

Used hopping table: North America
 Excluded RF carrier: 11
 SeQUENCECode (SQC): 3
 HoppingIndexOffset (HIO): 0 and 2

Frequency versus slot

| Frame | 0 | 1 | 2 | 3 | 4 | 5 | 6 | 7 | 8 | 9 | 10 | 11 | 12 | 13 | 14 | 15 | 16 | 17 | 18 | 19 | PHIN |
|-------|---|---|-----------|---|-----------|---|---|---|---|---|----|----|----|----|----|----|----|----|----|----|------|
| N | | | 49 | | 26 | | | | | | 3 | 3 | 3 | 3 | 65 | 3 | 3 | 3 | 3 | 3 | 0 |
| N+1 | | | 3 | | 65 | | | | | | 23 | 23 | 26 | 23 | 46 | 23 | 23 | 23 | 23 | 23 | 1 |
| N+2 | | | 26 | | 46 | | | | | | 62 | 62 | 65 | 62 | 46 | 62 | 62 | 62 | 62 | 62 | 2 |
| N+3 | | | 65 | | 46 | | | | | | 11 | 11 | 46 | 11 | 19 | 11 | 11 | 11 | 11 | 11 | 3 |
| N+4 | | | 46 | | 19 | | | | | | 46 | 46 | 46 | 46 | 74 | 46 | 46 | 46 | 46 | 46 | 4 |

3.4 PP synchronization procedure

PP selects a random RF carrier and tries to receive a frame within 0.9 sec. If nothing is received then a new RF carrier is selected.

When a burst with correct A-CRC is received and it is a Nt (RFPI) the hopping sequence (SQC) is known and the PP must receive in the following frames using the hopping sequence. If the received A-field is

| | | | | |
|---|---|-----------------|---------------------|----------------------|
|  | Technical Documentation MARS 2G4 Freq. Hopping | | | Specification |
| | File marsalgorithmstypeappr oval.doc | Date 1999-09-09 | Revision 0.4 | Ref. JTP/FM |

different from a Nt, the PP selects a new RF carrier randomly and waits for Nt. In this state the PP do not have information of excluded RF carriers, but just follows the known hopping sequence without excluding any RF carriers. Only individual frames are missed on the excluded carriers. When PT3 is received, the PP is able to receive on exception carriers.

3.5 Dual slot diversity

Dual slot diversity is activated in case interference is detected. That is, two bearers are active, carrying the same B-field content. The receiver decides which of the received speech frames to use, depending on A-CRC and/or X-CRC. The setup and release of the 2nd bearer are performed dynamically by the FP-MAC and PP-MAC to adapt to current interference level. The two bearers are managed independently in the MAC, like a stalled intra-cell bearer hand-over with two established bearers. HoppingIndexOffset (HIO) for the two bearers are selected independently.

3.6 Power amplifier activation

3.6.1 External connection

The FP has one connection active at all times to make synchronization of the PP possible. In case a speech connection is active one slot will be active in down-link direction and one slot will be active from in up-link direction. The power amplifier will be active from start of sync field to the end of XZ field, which is slightly less than 1/24 of the total frame. In case dual slot diversity is active, two slots will be active equal to 2/24 of a frame.

3.6.2 Internal connection

Two handsets are able to make an internal connection. In this case two bearers will be active in the down-link direction from FP, and one bearer will be active from each handset. The two bearers in down-link direction are not correlated and uses different HoppingIndexOffset. Dual slot diversity is activated independently towards each handset, i.e. up to four bearers may be activated in down-link direction, and two bearer may be active in up-link direction.

| | | | | |
|---|---|---------------------|-------------|----------------------|
| R T X | Technical Documentation MARS 2G4 Freq. Hopping | | | Specification |
| File marsalgorithmstypeapproval.doc | Date 1999-09-09 | Revision 0.4 | Ref. JTP/FM | Page 9 of 9 |

System description

This document describes the complete Kirk MARS system in overall terms. The system described below is a DECT system, but the KIRK MARS system is designed in the same way and thus functionality is the same as the KIRK dect-z System 1500.

The only difference is the RF communication through the air which is frequency hopping 2.4 GHz instead of DECT at 1.8 GHz. The system consist of a CCFP (central unit), a RFP (Radio Fixed Part), a WRFP (Repeater) and some handset.

The only part, made by RTX telecom, that must be approved are RFP, WRFP and PP

The drawing below show the system where the RFP is connected to the CCFP through a telephone wire. The handset can have a connection through the repeater to the RFP or directly to the RFP.

The RFP is powered from the CCFP through the telephone wire.

Below the drawing we have put in some descriptions of this system.

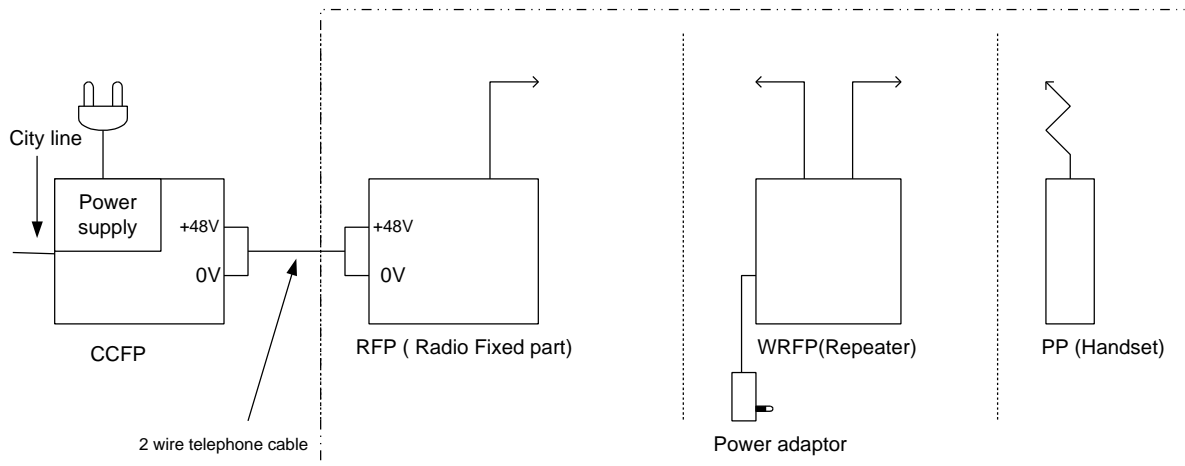

Products

The KIRK dect-z System 1500 is expandable up to a max of 128 cordless DECT handsets and 32 base stations in its fully expanded version.

The system consists of four different parts: A control unit which is connected to the switch board (PABX) of the company.

A number of base stations has to be placed at different places in the company - they are needed for the support of the coverage area. Chargers in which the handsets are placed for charging, e.g. overnight and finally the KIRK dect-z handset, the small and very user-friendly cordless telephone.

The easy installation of the KIRK dect-z System 1500 makes it outstanding. You simply connect it to the existing PABX in your company. There is not necessarily any need to lay out new cables or invest in other radical installations.

The user gets - beyond the already known facilities from the switch board - a large scale of new facilities, e.g. caller identification, registration of your handset with name and number etc.

If you need further information about any of the particular parts of the KIRK dect-z System 1500 or general information on DECT telecommunication you just click on one of the below mentioned items:

| | | | | |
|--|--------------------------------|-----------------------|-----------|---------------------------|
| | Technical Documentation | | | System description |
| | Date: 2001-04-07 | File: Kirk_System.doc | Ref.: MGP | Rev.: 1 |
| | | | | Page: 1 of 5 page(s) |

CCFP (Control Unit)

The Control Unit or CCFP controls the communication between the subscribed handsets and the PABX/switch board as well as the telephone traffic between the base stations in order to have the radio covered area appearing as one unique radio network where the user has no need to know how the telephone traffic is working.

Connection of base stations:

The Control Unit has in its basic version 8 connections for base stations and may be enlarged to another 8 base stations with an extra card, i.e. the maximum enlargement of the base stations is 16. The number of base stations needed depends of the coverage area. In specific areas with high telephone traffic it may be necessary to install an extra base station.

Connection of handsets:

The Control Unit contains an IWU card (Inter Working Unit). The card having 8 analogue lines is connected to the switch board. The number of IWU cards to be installed depends of the number of cordless handsets to be connected to the system. The Control Unit can as a maximum be extended with 8 IWU cards corresponding to 64 cordless handsets in all.

The analogue connection at the Control Unit contains the following possible settings:

- Signalling: DTMF or Pulse
- Recall function: Loop break / Earth Pulse
- Ringing frequency: 25 Hz - 50 Hz
- Public network: Dial tone detect pause
- Transmission: Parallel operation down to 8 mA

So the KIRK dect-z System 1500 is a flexible system offering many possibilities of individuality to already installed as well as new switch boards. It is the users decision whether to connect the handset parallel to the existing corded telephone and with that the same local extension number or to connect the cordless telephone to its own local extension number. The KIRK dect-z handset can only be installed parallel to an analogue telephone.

System features:

The KIRK dect-z System 1500 does not contain proper switch board facilities but may be considered as transparent seen from the switch board. This is to avoid conflicts arising between the existing switch board's facilities and the KIRK dect-z System 1500.

GAP standard:

The KIRK dect-z System 1500 is based on the open DECT standard GAP (Generic Access Profile), i.e. the handset is applicable to other GAP systems as well as other GAP handsets are applicable to the KIRK dect-z System 1500.

To the users of a DECT handset this means that they in the future may choose cordless telephones from different manufacturers to cover special demands and at the same time choose other cordless DECT equipment e.g. a cordless fax or stationary cordless local extension telephones. In this way the company avoids to make new installations when moving employees around.

Text messages:

When registering the handset a text string may be encoded, e.g. the user's name. This text is then shown in the display when the handset is subscribed to the system. It also helps you to identify your handset among the others in a multi charger or elsewhere. Furthermore the

| | | | | |
|---|--------------------------------|-----------|---------|---------------------------|
|  | Technical Documentation | | | System description |
| Date: 2001-04-07 | File: Kirk_System.doc | Ref.: MGP | Rev.: 1 | Page: 2 of 5 page(s) |

receptionist easily finds out whom among the staff is out of the house if they have left their handsets in a multi charger in the reception.

The KIRK dect-z contains a so-called CLIP (Calling Line Identification Presentation) function making it possible to see who is calling, either in name or with a telephone number.

RFP (Radio Fixed Part)

The RFP (Radio Fixed Part) is the base station of the system. Up to 16 base stations may be connected to the system in its basic version.

Features of one base station:

- Supports 4 simultaneous DECT traffic channels
- Remotely powered from the Control Unit
- Operates on standard two wired telephone cables

The base stations of KIRK dect-z are easy to install. They are connected to the Control Unit as ordinary analogue telephones, i.e. through an ordinary two wired duplex telephone cable. The base stations are powered from the same cable.

At a normal installation the Control Unit is mounted next to the main distributing frame of the switch board. If you have a surplus of cables these may be used to connect the base stations and as such facilitate the installation work. It is not necessary to measure out the cables to install KIRK dect-z System 1500. This is automatically done from the Control Unit when the installation is completed.

A good DECT system is conditional on a certain overlap between the base stations within the coverage area. It is of great importance having enough base stations installed. Because of the two wired cable connection between the base stations and the Control Unit each base station is only able to handle 4 simultaneous telephone conversations.

This corresponds to 8-10 DECT users within the coverage area of one base station. If it is necessary to have further DECT users within a coverage area the system may be enlarged with an extra base station.

WRFP (repeater)

The latest product from KIRK telecom is a repeater meant for the KIRK dect-z System 1500. The repeater extends the DECT system's coverage area and may be seen as a cordless base station. The repeater needs radio contact with just one base station in your DECT system and no cabling to the control unit.

The repeater is primarily meant for areas with low traffic intensity, e.g. in peripheral areas or - if an external antenna is coupled - in remote areas from the original coverage area of your DECT system.

The new repeater from KIRK telecom provides you with the possibility of covering "holes" in your DECT system's coverage area at very low installation costs, e.g. in places having "shadows" in the radio coverage as in stair cases, storage and warehouses or cellars and lofts etc.

It is very easy and fast to install the new repeater while it is feeded directly from the power supply via the enclosed adapter. Configuration of the repeater is made very smoothly with a matching programming kit and a Windows installation programme, logical and simple in its application. You have to buy the programming kit separately but the Windows installation programme may be downloaded directly from KIRK

| | | | | |
|---|--------------------------------|------------------|----------------|-----------------------------|
|  | Technical Documentation | | | System description |
| Date: 2001-04-07 | File: Kirk_System.doc | Ref.: MGP | Rev.: 1 | Page: 3 of 5 page(s) |

telecom's homepage: www.kirktelecom.dk - free of charge - from the menu "Download". You may also order the programme at KIRK telecom and will then be charged a smaller administration fee.

The size of the repeater is only (LxWxH): 150 x 80 x 35 mm.

PP4 Handset

The handsets of the KIRK dect-z System 1500 are small and very userfriendly telephones. Each telephones size and weight allows it easily to be carried, e.g. in your pocket. However, the size of the handset has not influenced the display which clearly shows numbers and text, nor the keyboard having several key functions. The KIRK dect-z handset has a speech time of 10 hours and a standby time of 90 hours, corresponding to app. two days of normal use without charging the battery. Follow the links below to learn more about your favorite KIRK telecom handset.

Handset 3040 from KIRK telecom

KIRK telecom is a Danish producer of advanced telecommunications solutions that break with conventional standards in the areas of design and functionality. In order to maintain the position as one of the market leaders in business DECT systems, the department for Research and Development has developed a new handset, not only for the **KIRK dect-z 1500 cordless telephone system**, but for any system compatible with the DECT/GAP standard.

The new handset from KIRK telecom – **KIRK Z-3040** – is packed with a wide range of advanced features and facilities. Below you will find a few examples of the functions that the technical wizards have managed to include in the **KIRK Z-3040** handset:

- CCITT Alphanumeric Keyboard
- Telephone book with room for 80 numbers
- Programming of 2 different set-ups (for example indoor/outdoor mode)
- 36 character display with backlight
- Stack for 10 caller-ID presentations
- Stack for 10 redial presentations
- 9 different ringtones and adjustable ringer volume
- Headset connection
- Vibrator

"The **KIRK Z-3040** handset from KIRK telecom is not supposed to replace the original KIRK dect-z handset, which users of DECT systems all over the world have come to love," states Peter Skov, Managing Director KIRK telecom.

"We have no intention of withdrawing a modern, technologically advanced product from the market. Actually we have improved the dect-z handset with new software and a built-in vibrator as standard. And with the introduction of the new **KIRK Z-3040**

| | | | | |
|---|-------------------------|-----------------------|-----------|--------------------|
|  | Technical Documentation | | | System description |
| | Date: 2001-04-07 | File: Kirk_System.doc | Ref.: MGP | Rev.: 1 |



handset as a complementary product, we hope to satisfy even more users of state-of-the-art cordless telecommunication."

| | | | | |
|-------------------------|--------------------------------|------------------|----------------|-----------------------------|
| | Technical Documentation | | | System description |
| Date: 2001-04-07 | File: Kirk_System.doc | Ref.: MGP | Rev.: 1 | Page: 5 of 5 page(s) |

This document and the information contained is property of RTX Telecom A/S, Denmark. Unauthorized copying is not allowed. The information in this document is believed to be correct at the time of writing. RTX Telecom A/S reserves the right at any time to change said content, circuitry and specifications.

Applicant's declaration of implementation

It's hereby declared that the product:

.....RFP4 2G4.....

fulfills the requirement in FCC test relating to the antenna type.

TheRFP4 2G4.....confirm to FCC recommendation with internal antenna type:

simple wire antenna (1/4 wave antenna)
With the gain of 0 dBi
frequency range 2401.280 MHz to 2481.152 MHz.

The mounting of the antenna is fixed to the radio module and no other antenna should be used.

Company: KIRK telecom A/S

Address: Langmarksvej 34

City: Horsens

ZIP / Postal code: DK-8700

Country: Denmark

Signature:



Date:

8/6 - 07



Langmarksvej 34 - DK-8700 Horsens