



EUROFINS ETS PRODUCT SERVICE GMBH

TEST - REPORT

FCC PART 15 D for Isochronous UPCS devices
RSS-213 for LE-PCS devices

FCC ID: PXAPP6N40-1G9

Test report no.:

G0M20801-0399-C-1



Certificate #1983.01

TABLE OF CONTENTS

1 General information

- 1.1 Notes
- 1.2 Testing laboratory
- 1.3 Details of approval holder
- 1.4 Application details
- 1.5 Test item
- 1.6 Test standards

2 TECHNICAL TEST

- 2.1 Summary of test results
- 2.2 Test environment
- 2.3 Test equipment utilized
- 2.4 Examinations and Test Procedures

3 RESULTS OF EXAMINATIONS AND TESTS

- 3.1. Examinations and Test Procedures
 - 3.1.1 Coordination with fixed microwave service, FCC 15.307 (b)
 - 3.1.2 Reference to Subpart B, FCC 15.309 (b)
 - 3.1.3 Conducted limits AC Power line, FCC 15.315, 15.207; RSS-213 4.2; 6.3
 - 3.1.4 Antenna requirement, FCC 15.317, 15.203
 - 3.1.5 Modulation techniques, FCC 15.319 (b); RSS-213 6.1
 - 3.1.6 Emission bandwidth, FCC 15.323 (a); FCC 15.31 (e); RSS-213 6.4
 - 3.1.7 Peak Transmit Power, FCC 15.319 (c); RSS-213 4.3.1, 6:5
 - 3.1.8 Power spectral density, FCC 15.319 (d); RSS-213 4.3.1, 6:6
 - 3.1.9 Directional gain of the antenna, FCC 15.319 (e); RSS-213 4.1 (e)
 - 3.1.10 Automatic discontinuation of transmission, FCC 15.319 (f); RSS-213 4.3.4 (a)
 - 3.1.11 Radio frequency radiation exposure, FCC 15.319 (i); RSS-Gen 5.5
 - 3.1.12 Monitoring threshold; Least interfered channel; FCC 15.323 (c)(2); (c)(5) (c)(9); RSS-213 4.3.4 (b)(2)
 - 3.1.13 Monitoring of intended transmit window and maximum reaction time, FCC 15.323 (c)(1); RSS-213 4.3.4 (b)(1)

- 3.1.14 Monitoring bandwidth, FCC 15.323 (c)(7); RSS-213 4.3.4 (b)(7)
- 3.1.15 Random waiting interval, FCC 15.323 (c)(6); RSS-213 4.3.4 (b)(6)
- 3.1.16 Duration of transmission, FCC 15.323 (c)(3); RSS-213 4.3.4 (b)(3)
- 3.1.17 Connection acknowledgement, Unacknowledged transmissions, FCC 15.323 (c)(4); RSS-213 4.3.4 (b)(5)
- 3.1.18 Selected channel confirmation, Segment occupancy; FCC 15.323 (c)(5)
- 3.1.19 Monitoring antenna, FCC 15.323 (c)(8); RSS-213 4.3.4 (b)(8)
- 3.1.20 Duplex connections, FCC 15.323 (c)(10); RSS-213 4.3.4 (b)(10)
- 3.1.21 Alternative monitoring interval for co-located devices, FCC 15.323 (c)(11); RSS-213 4.3.4 (b)(11)
- 3.1.22 Fair access to spectrum related to (c)(10) and (c)(11), FCC 15.323 (c)(12); RSS-213 4.3.4 (b)(12)
- 3.1.23 Emissions inside and outside the sub-band, FCC 15.323 (d); RSS-213 6.7
- 3.1.24 Frame period, FCC 323 (e); RSS-213 4.3.(c).
- 3.1.25 Frequency stability, FCC 323 (f); RSS-213 6.8
- 3.1.26 Receiver spurious emissions; RSS-213 6.8

1 General Information
1.1 Notes

The purpose of conformity testing is to increase the probability of adherence to the essential requirements or conformity specifications, as appropriate.

The complexity of the technical specifications, however, means that full and thorough testing is impractical for both technical and economic reasons.

Furthermore, there is no guarantee that a test sample which has Passed all the relevant tests conforms to a specification.

Neither is there any guarantee that such a test sample will interoperate with other genuinely open systems.

The existence of the tests nevertheless provides the confidence that the test sample possesses the qualities as maintained and that its performance generally conforms to representative cases of communications equipment.

The test results of this test report relate exclusively to the item tested as specified in 1.5.

The test report may only be reproduced or published in full.

Reproduction or publication of extracts from the report requires the prior written approval of the Eurofins ETS Product Service GmbH.

Specific Conditions:

Usage of the hereunder tested device in combination with other integrated or external antennas requires at least additional output power measurements, spurious emission measurements, conducted emission measurements (AC supply lines) and radio frequency exposure evaluations for each individual configuration are performed, for certification by competent authorities FCC; IC.

This report is related to FCC Part 15 D applied to UPCS devices of which technology is derived from DECT standard.

Additional this report covers the requirement of RSS-213, 2 GHz Licence exempt Personal Communications Services Devices (LE-PCS) released by Industry Canada (IC). In following the term UPCS covers the term LE-PCS too.

Tester:

07.03.2008

W. Treffke



Date

ETS-Lab.

Name

Signature

Technical responsibility for area of testing:

07.03.2008

K. Damm



Date

ETS

Name

Signature

1.2 Testing laboratory

1.2.1 Location

EUROFINS ETS PRODUCT SERVICE GMBH
Storkower Str. 38c
15526 Reichenwalde b. Berlin
Germany

Telefon : +49 33631 888 00
Telefax : +49 33631 888 66

1.2.2 Details of accreditation status

DAR ACCREDITED TESTING LABORATORY

DAR-REGISTRATION NUMBER: DAT-P-268/08

RECOGNIZED NOTIFIED BODY EMC

REGISTRATION NUMBER: BNetzA-bS EMV-07/61

RECOGNIZED NOTIFIED BODY R&TTE

REGISTRATION NUMBER: BNetzA-bS-02/51-53

FCC FILED TEST LABORATORY

REG.-No. 96970

A2LA ACCREDITED TESTING LABORATORY

CERTIFICATE No. 1983.01

BLUETOOTH QUALIFICATION TEST FACILITY (BQTF)

ACCREDITED BY BLUETOOTH QUALIFICATION REVIEW BOARD

INDUSTRY CANADA FILED TEST LABORATORY

REG. NO. IC 3470

1.3 Details of approval holder

Name : POLYCOM KIRK telecom ApS
Street : Langmarksvej 34
Town : 8700 Horsens
Country : Denmark
Telephone : +45 7628 1280
Fax : +45 7560 2851

Contact : Mr. Henrik Birch Rasmussen
Telephone : +45 7628 1280
E-mail : henrik.rasmussen@polycom.com

1.4 Application details

Date of receipt of application : 23.01.2008
 Date of receipt of test item : 23.01.2008
 Date of test : 14.02.2008 – 06.03.2008

1.5 Test item

Description of test item : Isochronous UPCS device, cordless phone based on DECT modified technology.

Function	
Portable part	<input checked="" type="checkbox"/>
Base station	
Repeater	

Description of test item : UPCS (DECT based) handset (PP)
 Type identification : PP6N40 1G9
 Portable Part
 Serial number : Test model without serial number.
 Photos : See annex

Technical data

Frequency bands : 1920 – 1930 MHz

Operating Channel numbers	Test Frequencies	Channel center frequency (MHz)
4	F_L	1921.536
3		1923.264
2	F_M *)	1924.992
1		1926.720
0	F_U	1928.448

*) for frequency stability test and spurious emission test in RX mode only

Number of channels : 60 (in time and spectrum window, declared by manufacturer)
 Operating modes : MC/TDMA/TDD
 Type of modulation : GFSK

Max. slot type:

single slot	<input checked="" type="checkbox"/>
double slot	<input type="checkbox"/>

Fixed point-to-point operation: Yes/No

Antenna	Type	Gain [dBi]	internal	external
0	Ceramic monopole antenna	0	<input checked="" type="checkbox"/>	<input type="checkbox"/>
1	ANT8030-2R4-01	2	<input checked="" type="checkbox"/>	<input type="checkbox"/>

Antenna connector : ./.

Antenna diversity :

Antenna	Diversity supported	
	Tx	Rx
0	<input checked="" type="checkbox"/>	<input type="checkbox"/>
1	<input checked="" type="checkbox"/>	<input type="checkbox"/>

Host device : none

Classification : related to radio frequency radiation exposure

Fixed Device	<input type="checkbox"/>
Mobile Device (Human Body distance > 20cm)	<input type="checkbox"/>
Portable Device (Human Body distance < 20cm)	<input checked="" type="checkbox"/>

Power supply : 3.7 V DC 120 V AC/DC Adapter

Data connection :

Connection	used
None	<input type="checkbox"/>
PSTN	<input type="checkbox"/>
Data Networks	<input type="checkbox"/>
others	<input checked="" type="checkbox"/>

Remark: Devices intended to be connected to PSTN have to be applied for FCC PART 68 registration, in USA and for Industry Canada standard CS-03.

Manufacturer:
(if applicable)

Name : POLYCOM KIRK telecom ApS
Street : Langmarksvej 34
Town : 8700 Horsens
Country : Denmark

1.6 Test standards

Technical standard : FCC PART 15, Subpart D; RSS-213

Test method and procedure: Following requirements of FCC Part 15 D, RSS-213 and ANSI C63.17-1998 (Revision Draft 3.5 , January 14, 2006 if applicable)

Additional information : The row scheme for frequency generation, radio channels, receiver parameters, synchronization procedure, and other parameters are determined by the DECT standard. Details are content of operational description provided by manufacturer.

2 Technical test

2.1 Summary of test results

No deviations from the technical specification(s) were ascertained in the course of the tests performed.

or

The deviations as specified in 2.5 were ascertained in the course of the tests performed.

2.2 Test environment

Temperature : 25°C

Relative humidity content : 20 ... 75 %

Air pressure : 86 ... 103 kPa

Details of power supply : 3.7 V DC 120 V AC/DC Adapter

Extreme conditions parameters: : test voltage - extreme min : 3.2 V, DC
(manufacturer declaration) max: 4.6 V, DC

temperatures – extreme min: -10°C ¹⁾
max: 55°C ¹⁾

Remarks: ¹⁾ declared by manufacturer

2.3 Test equipment utilized

No.	Test equipment	Type	Manufacturer
ETS 0001	ESD Gun	SESD 30000	Schlöder
ETS 0002	Test receiver	ESVP	R & S
ETS 0003	Diode Power Sensor	NRV-Z2	R & S
ETS 0004	Spektrum- and Network-Analyzer	FSMS 26	R & S
ETS 0005	RF amplifier matrix	RSU-ETS-CTR6	ETS
ETS 0006	HP-Filter	H1G04G01	Microwave
ETS 0007	Horn antenna	AT 4004	ar
ETS 0008	Antenna	Loop antenna	Siemens
ETS 0009	Comb Generator Emitter	CGE 02	York EMC Services
ETS 0011	Antenna (van Veen/Frame)	HM020Z3	R & S
ETS 0012	Biconical Antenna	HK 116	R & S
ETS 0013	LPD Antenna	HL 223	R & S
ETS 0014	Log Periodical Antenna	HL 025	R & S
ETS 0015	Log Periodical Antenna	HL 025	R & S
ETS 0016	Precision antenna kit	VHAP	Schwarzbeck
ETS 0017	Precision antenna kit	UHAP	Schwarzbeck
ETS 0018	Horn antenna	BBHA 9120 D	Schwarzbeck
ETS 0019	Horn antenna	BBHA 9120 D	Schwarzbeck
ETS 0020	Antenna	DP 21	MEB
ETS 0021	Antenna	DP 3	MEB
ETS 0022	Antenna	SAS-200/ 521	A.H. Systeme+D65
ETS 0023	Antenna	DP 1	MEB
ETS 0024	Antenna mast	AF 2	MEB
ETS 0025	Antenna mast	AF 2	MEB
ETS 0026	Tripod		Heinrich Deisel
ETS 0027	Tripod		Heinrich Deisel
ETS 0028	Tripod	STA 2	C. Lorenz AG
ETS 0029	Tripod		Berlebach
ETS 0030	Biconical Antenna	HK 116	R & S
ETS 0031	Turn table	DS 412	Heinrich Deisel
ETS 0032	Controller	HD 050	Heinrich Deisel
ETS 0033	Calibr. Set CDN	3x Adaptor 50-150 Ohm	ETS
ETS 0034	RF Generator/ Amplifier	SMLR	R & S
ETS 0035	RF Generator/ Amplifier	SMLM	R & S
ETS 0036	Zirc. Antenna	3102	EMCO
ETS 0037	Zirc. Antenna	3102L	EMCO
ETS 0038	RF amplifier	150L	Amplifier Research
ETS 0039	Absorbing clamp	MDS 21	R & S
ETS 0040	Artificial Mains Network	ESH3-Z5	R & S

Test Report No.: G0M20801-0399-C-1

No.	Test equipment	Type	Manufacturer
ETS 0041	T-Artificial Mains Network	ESH3-Z4	R & S
ETS 0042	Artificial Mains	ESH3-Z6	R & S
ETS 0043	Directional Coupler	1850	KRYTAR
ETS 0044	Vehicle LISN	NNBM 8125	Schwarzbeck
ETS 0045	Vehicle LISN	NNBM 8126D	Schwarzbeck
ETS 0046	Power supply	2224.7	Statron
ETS 0047	Power supply	2224.7	Statron
ETS 0048	Power supply	2224.7	Statron
ETS 0049	Power supply	2228.1	Statron
ETS 0050	Power supply	2224.2	Statron
ETS 0051	Oscilloscope	TDS 640A	Tektronix
ETS 0051a	Probe a	P6139A	Tektronix
ETS 0051b	Probe b	P6139A	Tektronix
ETS 0052	Audio analyzer	UPA 4	R & S
ETS 0056	Ultra Compact Simulator	UCS 500 M4	EM Test
ETS 0057	Motor Variac	MV 2616	EM Test
ETS 0058	Capacitive coupling clamp	E 502 B	Keytek/ EMC
ETS 0059	Kikusui amplifier	PCR 2000L	Keytek/ EMC
ETS 0064	CDN IEC 61000-4-6		Keytek/ EMC
ETS 0066	EM Injection Clamp		FCC/ EMC
ETS 0067	Calibration Fixture	IEC 801-2031 CF	FCC/ EMC
ETS 0068	CDN IEC 61000-4-6	CDN	FCC/ EMC
ETS 0069	EM Radiation Monitor	EMR-20	W & G
ETS 0070	PC Transfer set EMR-20	EMR-20	W & G
ETS 0071	Video camera system	KMB012	Kocom
ETS 0072	Interphone system	JS-1400	Jiuh Sheng
ETS 0073	Audio noise meter	GSM 2	MKD/ RFT
ETS 0075	NF Generator	GF 22	Präcitronic
ETS 0076	Feeding bridge A	SBA 1000	ESP
ETS 0078	LCR meter	SR 720	SRS
ETS 0079	Functional Generator	MX-2020	Maxcom
ETS 0082	PC system		Esotronic
ETS 0085	Shielded room	SR 1	Frankonia
ETS 0086	Semi-Anechoic chamber	AC 1	Frankonia
ETS 0087	Climatic cell	HC 4033	Heraeus
ETS 0088	Color TV pattern Generator	PM 5518-TX VPS	Philips
ETS 0089	Radio Communication tester	CMS 54	R & S
ETS 0091	Signal Generator	SME 03	R & S
ETS 0092	Power Amplifier	150W1000	AR Amplifier Research
ETS 0093	Attenuator	57-20-33	Weinschel
ETS 0094	Power Sensor	NRV-Z55	R & S
ETS 0095	DECT system controller	PSMD	R & S
ETS 0096	DECT Signaling unit	PSMD-B11	R & S
ETS 0097	Rack, 19", 36 HU	TS 89RA	R & S
ETS 0098	System engineering and software	CS 893BE	R & S

Test Report No.: G0M20801-0399-C-1

No.	Test equipment	Type	Manufacturer
ETS 0099	Extension unit for basic version	TS 8930B	R & S
ETS 0100	Signal Generator	SME-06	R & S
ETS 0101	Power Amplifier	50W1000B	AR Amplifier Research
ETS 0102	CDN	M3-801/6	MEB
ETS 0103	Magnetic field test set	MF1000	EMC-Partner
ETS 0105	RF Signal Generator (High power synthesizer/ sweeper)	SMP 02 (SMP 22 / 02)	R & S
ETS 0106	Antenna	Vamp 9243	Schwarzbeck
ETS 0108	DECT protocol tester TBR 22	TS 1220	R & S
ETS 0110	Real time Signaling unit	PSMD-B2	R & S
ETS 0111	PCM Real-time audio interface for PSM	PSMD-B3	R & S
ETS 0112	Synthesizer Module	PSMD-B4	R & S
ETS 0114	RF step attenuator	RSG	R & S
ETS 0116	Protokolltester	PTW 70	R & S
ETS 0117	Insertion unit	URV5-Z2	R & S
ETS 0120	RF step attenuator	TRI-50-20	INCO
ETS 0121	Resonant loop	0003127-1880	ETS Lindgren
ETS 0122	Resonant loop	0003127-836	ETS Lindgren
ETS 0123	RF attenuator	RBU	R & S
ETS 0124	Tripod	STA 2	R & S
ETS 0125	Reference dipole	0003126-1880	ETS Lindgren
ETS 0126	Reference dipole	0003126-836	ETS Lindgren
ETS 0127	Circular polarized antenna	3102	ETS Lindgren
ETS 0128	Dual Horn Antenna	3164-04	EMCO
ETS 0136	Attenuator	33-6-34	Weinschel
ETS 0140	High voltage Generator	IP 6Wa	TPW
ETS 0141	Sliding bridge	J 573	RFT
ETS 0143	Impedance converter	TK 12	RFT
ETS 0144	Notch filter	WRCT 24000/2497-80-20SS	Wainwright
ETS 0145	Coaxial Directional	3002-20	Narda
ETS 0146	Active Voltage Probe	ESH2-Z2	R & S
ETS 0148	RF Current Probe	F-65	FCC
ETS 0149	Power divider	ZAPD-21	MCL
ETS 0150	Switcher	HR07-720	Wisi
ETS 0151	Interference pulse Generator	NSG 500C	Schaffner
ETS 0152	Simulator for Load-Dump-Impulse	NSG 506C (I)	Schaffner
ETS 0153	Simulator for Load-Dump-Impulse	NSG 506C (II)	Schaffner
ETS 0155	Signal Generator	SMG	R & S
ETS 0157	TV and Sat-Signalgenerator	VTG 700	Grundig
ETS 0159	Programmable power supply	TOE 8815	Toellner
ETS 0160	Amplifier	AR 1W1000	Amplifier Research
ETS 0161	Harmonic / Flicker Analyzer	HFA 3000	Schlöder
ETS 0162	Acoustic chamber	403-A	IAC

Test Report No.: G0M20801-0399-C-1

No.	Test equipment	Type	Manufacturer
ETS 0163	Test head	BK 4602	Brüel & Kjær
ETS 0164	Simulator ear	BK 4185	Brüel & Kjær
ETS 0165	Simulator mouth	BK 4227	Brüel & Kjær
ETS 0166	Sound level calibrator	BK 4231	Brüel & Kjær
ETS 0167	Communication Analysis System	CAS TE I	HEAD acoustics
ETS 0168	Acoustical test for DECT	CTR 10	HEAD acoustics
ETS 0169	Measurement - Front-end (analog)	MFE III	HEAD acoustics
ETS 0170	Measurement - Front-end (digital)	MFE IV	HEAD acoustics
ETS 0171	Electronic test cradle	TEH	HEAD acoustics
ETS 0172	Noise Generator	HNG III.1	HEAD acoustics
ETS 0173	Speaker	Canton S Pluss	HEAD acoustics
ETS 0174	Measurement - Front-end line interface	MFE V	HEAD acoustics
ETS 0175	Software Line interface (analog)	COPTZV5	HEAD acoustics
ETS 0176	Acoustic volt meter	COP 4	HEAD acoustics
ETS 0177	Feeding bridge B	SBB 1000	ESP
ETS 0178	Open area test side	10m	ETS
ETS 0179	Open area test side	3 m	ETS
ETS 0186	Power supply	DF 1730	WJG
ETS 0189	Spectrum Analyzer	FSEB	R & S
ETS 0191	Sweep function Generator	7202	Dagatron
ETS 0218	RF probe	URV5-Z7	R & S
ETS 0219	Power sensor	NRV-Z2	R & S
ETS 0221	ISDN-S0-Analyzer	K1403	Siemens
ETS 0222	ISDN Protocol Analyzer	TE965	Tekelec Teleco.
ETS 0223	GSM/ PCN/ PCS-Simul.	TS8916B	R & S
ETS 0224A	Millivolt meter	URV5	R & S
ETS 0224B	Diode Power Sensor	NRV-Z1	R & S
ETS 0224C	Programmable high resolution timer counter	PM6654G	Philips
ETS 0224D	RF Stepp Attenuator	RSP	R & S
ETS 0224E	Signal Generator	SMG	R & S
ETS 0225	SIM Simulator		Orga
ETS 0226	SIM Editor		Orga
ETS 0227	Vibration table	TIRA vib	GenRad
	Accelerator	PCB_M353B33	PCB Piezotronics Inc.
ETS 0228	Climatic chamber	VT 4010	Vötsch
ETS 0229	Radio Communication. Tester	CMT 54	R & S
ETS 0230	Radio Communication. Tester	CMD 65	R & S
ETS 0232	Radiation test source	VSQ 1	MEB
ETS 0233	Direction coupler	RK 100	MEB
ETS 0234	Power meter	NRVD	R & S
ETS 0235	RF-network-Analyzer	8752 C	HP
ETS 0236	RF-amplifier	100A100	ar

Test Report No.: G0M20801-0399-C-1

No.	Test equipment	Type	Manufacturer
ETS 0237	RF-amplifier	100W1000M1	ar
ETS 0238	Field strong meter	FM 2000	ar
ETS 0239	Isotropic field probe 40 GHz	FP 2080 Kit	ar
ETS 0240	Isotropic field probe 1 GHz	FP 2000 Kit	ar
ETS 0241	Pulse Generator	4050	PicoSecond PL
ETS 0244	Ultra Compact Simulator	UCS 200 M	EM-Test
ETS 0245	Load dump Generator	LD 200 B1	EM-Test
ETS 0246	Voltage drop simulator	VDS 200	EM-Test
ETS 0247	Calibration adaptor	KW50	EM-Test
ETS 0248	Calibration adaptor	KW1000	EM-Test
ETS 0251	Climatic chamber	VT 4004	Vötsch
ETS 0252	System controller	PSM 12	R & S
ETS 0253	Spectrum Analyzer	FSIQ 26	R & S
ETS 0254	RF Generator	SMIQ 03	R & S
ETS 0255	RF Generator	SMIQ 03	R & S
ETS 0256	RF Generator	SMR 27	R & S
ETS 0257	Step attenuator	RSP	R & S
ETS 0258	Rubidium standard	RSTU	DATUM GmbH
ETS 0259	Power meter	NRVD	R & S
ETS 0260	Power sensor	NRV-Z1	R & S
ETS 0261	Power sensor	NRV-Z1	R & S
ETS 0262	Switching unit	SSCU	R & S
ETS 0263	Signaling unit	PTW 60	R & S
ETS 0265	Loop antenna	HFRA 9150	Schwarzbeck
ETS 0266	Messadapter 1:100	50 Ohm	
ETS 0267	RF Signal Generator	SMT 03	R & S
ETS 0268	Signal Generator	SMP 02	R & S
ETS 0269	RF bridge 50 Ohm	86205 A	Agilent
ETS 0270	Signal Generator	SMP 04	R & S
ETS 0271	Spectrum Analyzer	FSEK 30	R & S
ETS 0272	Signal Generator	SME 03	R & S
ETS 0273	Signal Generator	SME 03	R & S
ETS 0274	Signal Generator	SMY 01	R & S
ETS 0275	Power sensor	NRV-Z51	R & S
ETS 0276	Audio Analyzer	UPL 16	R & S
ETS 0277	Power sensor	NRV-Z1	R & S
ETS 0278	Power sensor	NRV-Z31	R & S
ETS 0279	Step attenuator	RSP	R & S
ETS 0280	Power meter	NRVD	R & S
ETS 0281	Spectrum Analyzer	FSM	R & S
ETS 0282	RF bridge 75 Ohm	86207 A	HP
ETS 0283	RF bridge 50 Ohm	86205 A	HP
ETS 0284	Field probe	11940 A	HP

Test Report No.: G0M20801-0399-C-1

No.	Test equipment	Type	Manufacturer
ETS 0285	Field probe	11941 A	HP
ETS 0286	Limither	11867 A	HP
ETS 0287	EMI Test receiver	ESHS10	R & S
ETS 0288	Artificial mains	ESH2-Z5	R & S
ETS 0289	Audio Generator	TAG 101	Troneer
ETS 0290	Audio Generator	TAG 101	Troneer
ETS 0291	Loop antenna	HFH2-Z2	R & S
ETS 0292	RF Generator	SMHU	R & S
ETS 0293	Artificial mains	NNBM 8125	Schwarzbeck
ETS 0294	Biconical antenna	HK 116	R & S
ETS 0295	LPD antenna	HL 223	R & S
ETS 0296	GTEM cell	GTEM 500	Schaffner
ETS 0297	Power pulse Generator	IGUF 2910	Schwarzbeck
ETS 0299	DECT protocol tester	TS 1220	R & S
ETS 0300	RF amplifier	75 A 250	ar
ETS 0301	Relay switch unit	RSU	R & S
ETS 0302	Data line CDN	CM-I/O CD	Keytek
ETS 0303	Telecom line CDN	CM-TEL CD	Keytek
ETS 0306	Function Generator	HP 33120A	HP
ETS 0307	Commu. Sign. Analyzer	CSA 803 A	Tektronix
ETS 0308	Spectrum analyzer	R 3361A	Advantest
ETS 0309	Anechoic chamber	AC 2	Frankonia
ETS 0310	Anechoic chamber	AC 3	Frankonia
ETS 0311	Anechoic chamber	AC 4	Frankonia
ETS 0313	Power sensor	NRV-Z51	R & S
ETS 0314	LPD antenna	HL 223	R & S
ETS 0315	Biconical antenna	HK 116	R & S
ETS 0316	Switcher	Hr 07-720	WISI
ETS 0318	Dial pulse/ DTMF tester	210	HE
ETS 0319	Opto link	GPIB 140	NI
ETS 0320	Opto link	GPIB 140	NI
ETS 0322	Insertion unit	URV5-Z4	R & S
ETS 0328	ELF Field Strength Measurement System	HI-3604	Holiday Ind., INC.
ETS 0329	VDT / VLF Radiation Measurement System	HI-3603	Holiday Ind., INC.
ETS 0330	Fiber Optic Remote Control	HI-3616	Holiday Ind., INC.
ETS 0331	TS 1220		
ETS 0332	PSM		
ETS 0333	Turn table	DE 350	Heinrich Deisel
ETS 0334	Controller	HD 100	Heinrich Deisel
ETS 0336	LPD antenna	HL 223	R & S
ETS 0338	Coupling network	KN002	ETS
ETS 0339	Isolating Transformer	KN003	ETS

Test Report No.: G0M20801-0399-C-1

No.	Test equipment	Type	Manufacturer
ETS 0347	Current Probe	EZ-17	R & S
ETS 0348	RF Millivolt meter	URV 55	R & S
ETS 0350	Horn Antenna	BBHA 9120-C	Schwarzbeck
ETS 0351	RF amplifier	DWT-18057	Microwave
ETS 0354	RF amplifier	DBS-0408N423	Microwave
ETS 0355	high pass	H03G12G3	Microwave
ETS 0356	high pass	H03G12G3	Microwave
ETS 0357	high pass	H08G18G3	Microwave
ETS 0358	RF amplifier	AFD3-010040-15-In	MITEQ
ETS 0359	RF amplifier	M/N AM-1331	MITEQ
ETS 0360	RF amplifier	DBS-0408N423	Microwave
ETS 0361	RF amplifier	DBS 1826N515	Microwave
ETS 0362	high pass	H03G12G3	Microwave
ETS 0363	high pass	H08G18G3	Microwave
ETS 0364	high pass	H08G18G3	Microwave
ETS 0365	Notch filter 2.4 GHz	WRCT2.40/248	Wain Wright
ETS 0366	high pass	H08G18G3	Microwave
ETS 0367	high pass	H03G12G3	Microwave
ETS 0368	Notch filter 0.5-1 GHz	BN86883	Schomandl
ETS 0369	Notch filter 210-500 MHz	BN86882	Schomandl
ETS 0370	Notch filter 15-90 MHz	BN86880	Schomandl
ETS 0371	Notch filter 85-250 MHz	BN86881	Schomandl
ETS 0372	Direction coupler	RK 100	MEB
ETS 0373	Direction coupler	DC3001	EMC
ETS 0374	DC Power Supply	NGSM32	R & S
ETS 0375	Vector Signal Gener.	SMIQ03B	R & S
ETS 0376	Signal Generator	SMP22	R & S
ETS 0377	Advanced Signal Conditioning Unit	ASCU850	R & S
ETS 0378	Advanced Signal Conditioning Unit	ASCU190	R & S
ETS 0379	Advanced Signal Conditioning Unit	ASCU180	R & S
ETS 0380	Advanced Signal Conditioning Unit	ASCU900	R & S
ETS 0381	Ethernet HUB	CS-HUB	R & S
ETS 0382	Vector Signal Gener.	SMIQ03B	R & S
ETS 0383	Spectrum Analyzer	FSU26	R & S
ETS 0384	Main Frame Signal and Conditioning Unit	SSCU-GW	R & S
ETS 0385	Protocol Slave	CRTU-RU (CRTU-G)	R & S
ETS 0386	Power meter	NRVD	R & S
ETS 0387	Power Sensor	NRV-Z1	R & S
ETS 0388	Power Sensor	NRV-Z1	R & S
ETS 0389	Fading Simulator	ABFS	R & S
ETS 0390	System PC PC3600	TS-PC36	R & S
ETS 0391	Rubidium Frequency Standard	DATUM 8040	DATUM GmbH
ETS 0392	RF Distribution	DATUM 6502	DATUM GmbH

Test Report No.: G0M20801-0399-C-1

No.	Test equipment	Type	Manufacturer
ETS 0393	Insertion unit	URV5-Z4	R & S
ETS 0394	Advanced Signal Conditioning Unit	ASCUFDD-WCDMA	R & S
ETS 0395	Universal Protocol Tester	CRTU-G	R & S
ETS 0396	Protocol Slave	CRTU-S	R & S
ETS 0397	Protocol Slave	CRTU-S	R & S
ETS 0398	Fading Simulator	ABFS	R & S
ETS 0399	Univ. Protocol Tester (Protocol Unit) (Radio Unit)	CRTU-W (CRTU-PU) (CRTU-RU)	R & S
ETS 0400	Univ. Protocol Tester (Protocol Unit) (Radio Unit)	CRTU-W (CRTU-PU) (CRTU-RU)	R & S
ETS 0401	MPEG2 Generator	DVG	R & S
ETS 0402	TV Messenger	SFQ	R & S
ETS 0403	RF Current Probe	F-140	FCC
ETS 0404	Exposure Level Tester	ELT-400	Narda
ETS 0405	Magnetic Field Probe 100 cm ²	2300/90.10	Narda
ETS 0406	Signal Generator	SML 02	R & S
ETS 0407	EMC Emission tester	Harmonics 1000	EMC Partner
ETS 0408	Transient 2000	TRA1Z191N	EMC Partner
ETS 0409	Stripline	DC220	Schwarzbeck
ETS 0410	BAN	1	ETS
ETS 0411	Universal Protocol Tester	CRTU-G	R & S
ETS 0412	Spectrum Analyzer	FSU 3	R & S
ETS 0413	Signal Analyzer	FSIQ 26	R & S
ETS 0416	Power Supply	EX752M	TTi
ETS 0417	Beacon Tester	BT100S	WS Tech. Inc.
ETS 0418	High pass filter 4 - 8 G		Microwave
ETS 0419	High pass filter 8 - 18 G		Microwave
ETS 0420	Amplifier 0.1-1 GHz	M/N AM-1331	MITEQ
ETS 0421	Amplifier 1-4 GHz	AFD3-010040-15-LN	MITEQ
ETS 0422	Amplifier 4-8 GHz	DBS-0408N423	Narda
ETS 0423	Amplifier 8-18 GHz	DWT-18057	Narda
ETS 0424	Amplifier 18-26.5 GHz	DBS-1826N515	Narda
ETS 0425	T-Artificial Mains Network	ESH3-Z4	R & S
ETS 0426	CDN	T4 HF	MEB
ETS 0427	Power sensor	NRV-Z6	R & S
ETS 0428	4-WIRE ISN with B1	ENY41	R & S
ETS 0429	Current Probe Test Jig	SW14 7LY	Chase
ETS 0430	Signal Generator	SML02	R&S
ETS 0431	AC Mains Adaptor	BS5733	Travel Emporium
ETS 0432	RF amplifier matrix	RSU-ETS-BT	ETS
ETS 0433	RF amplifier matrix	RSU-ETS-CTR6	ETS
ETS 0435	HP-Filter	H1G04G01	Microwave
ETS 0436	HP-Filter	H1G04G01	Microwave
ETS 0437	HP-Filter	H04G08G1	Microwave

Test Report No.: G0M20801-0399-C-1

No.	Test equipment	Type	Manufacturer
ETS 0438	HP-Filter	H0G408G1	Microwave
ETS 0439	Amplifier	DBS-1826N515	Narda-DBS-Microwave
ETS 0440	Amplifier	AM-1331	MITEQ
ETS 0441	Bluetooth Protocol Tester	PTW 60	R & S
ETS 0445	RF-Attenuator 6dB	50FH-006-300	JFK
ETS 0446	RF-Attenuator 30dB	50FH-030-300	JFK
ETS 0447	Artificial Mains Network	LN-KFZ/200	Heine
ETS 0448	RF Power Amplifier	AR 60S1G3	AR Amplifier Research
ETS 0449	Stäubli Robot	RX90B L	Stäubli
ETS 0450	Stäubli Robot Controller	CS/MBs&p	Stäubli
ETS 0451	DASY 4 Measurement Server		Schmid & Partner
ETS 0452	Control Pendant		Stäubli
ETS 0453	Compaq Computer	Pentium IV, 2GHz	Schmid & Partner
ETS 0454	Data Acquisition Electronics	DAE3V1	Schmid & Partner
ETS 0455	Dummy Probe		Schmid & Partner
ETS 0456	Dosimetric E-Field Probe	ET3DV6	Schmid & Partner
ETS 0457	Dosimetric E-Field Probe	ET3DV6	Schmid & Partner
ETS 0458	Dosimetric H-Field Probe	H3DV6	Schmid & Partner
ETS 0459	System Validation Kit	D900V2	Schmid & Partner
ETS 0460	System Validation Kit	D1800V2	Schmid & Partner
ETS 0461	System Validation Kit	D1900V2	Schmid & Partner
ETS 0462	System Validation Kit	D2450V2	Schmid & Partner
ETS 0463	Probe Alignment Unit	LBV2	Schmid & Partner
ETS 0464	SAM Twin phantom	V 4.0	
ETS 0465	Mounting Device	V 3.1	
ETS 0466	Directional Coupler	HP 87300B	HP
ETS 0467	Oval flat phantom	ELI 4	Schmid & Partner
ETS 0468	Isotropic E-Field Probe	ER3DV6	Schmid & Partner
ETS 0469	Dielectric Probe Kit	85070D	Agilent
ETS 0470	Amplifier	AM-1300-1103	withEQ
ETS 0472	Antenna	BTA-H	Frankonia
ETS 0473	GSM / UMTS System Simulator	TS 8950	R&S
ETS 0474	EMI Test Receiver	ESCS 30	R&S
ETS 0475	Amplifier	AFS4-00101800-U	withEQ
ETS 0476	EMI Test receiver	ESCS 30	R&S
ETS 0477	GPS-System (active GPS-antenne)	4490	HOPF
ETS 0478	Crystal filter	MQF 127.50-2400/F	Vectron International
ETS 0479	System Validation Dipoles	D300V3	Schmid & Partner
ETS 0480	System Validation Dipoles	D450V3	Schmid & Partner
ETS 0481	40GHz Standard Gain Horn with Amplifier	22240-25 CBL26402075	Flann Microwave
ETS 0482	40GHz High Gain Antenna	AT4560	Amplifier research
ETS 0483	Amplifier	AFD3010040-15-LN	MITEQ

Test Report No.: G0M20801-0399-C-1

No.	Test equipment	Type	Manufacturer
ETS 0484	Radio Communication Tester	CMU 200	R&S
ETS 0485	Radio Communication Tester	CMU 200	R&S
ETS 0486	Circular polarized antenna	3101L	EMCO
ETS 0487	Torso simulator		ETS
ETS 0488	EMI Test Receiver	ESHS10	R & S
ETS 0489	Rubidium Frequency Standard	MFS	DATUM
ETS 0490	Rubidium Frequency Standard	8040	DATUM
ETS 0491	RF Distribution	DATUM 6502	DATUM
ETS 0492	Industrial Controller	PSM12	R & S
ETS 0493	Protokoll Tester	PTW60	R & S
ETS 0494	Switching unit	SSCU	R & S
ETS 0495	RF Step Attenuator	RSP	R & S
ETS 0496	Spectrum Analyzer	FSP	R & S
ETS 0497	Power Meter	NRVD	R & S
ETS 0498	Diode Power Sensor	NRV-Z1	R & S
ETS 0499	Diode Power Sensor	NRV-Z1	R & S
ETS 0500	Signal Generator	SMIQ03	R & S
ETS 0501	Signal Generator	SMIQ03	R & S
ETS 0502	Power Splitter	DS-808-4	Macom
ETS 0503	Directional Coupler	IAW	Microwave Filter Company
ETS 0504	AMTS-Simulator A	Feeding Bridge A	Emmerich
ETS 0505	Diode Power Sensor	NRV-Z1	R & S
ETS 0506	Diode Power Sensor	NRV-Z6	R & S
ETS 0507	Power Divider	PS-Z101-4S	UMCC
ETS 0508	Power Divider	T-1000	Macom
ETS 0509	Power Divider	T-1000	Macom
ETS 0510	Power Divider	T-1000	Macom
ETS 0511	Power Divider	DS-409-4	Anzac
ETS 0512	Log Periodical Antenna	HL 025	R & S
ETS 0513	Flat Phantom	V4.4	Schmid & Partner
ETS 0514	Limiting amplifier	APT55-00100200-500-D66	Amplitech
ETS 0515	Limiting amplifier	APT55-00100200-500-D66	Amplitech

3 RESULTS OF EXAMINATIONS AND TESTS (enclosure)

TEST CASE	FCC Rules	RSS-213	Required	Customer Declaration	Test passed	Test failed
Coordination with fixed microwave service	15.307 (b)		<input checked="" type="checkbox"/>	<input checked="" type="checkbox"/>	<input type="checkbox"/>	<input type="checkbox"/>
Reference to Subpart B	15.309 (b)		<input type="checkbox"/>	<input type="checkbox"/>	<input type="checkbox"/>	<input type="checkbox"/>
Conducted limits AC Power line	15.315 , 15.207	4.2; 6.3	<input checked="" type="checkbox"/>	<input type="checkbox"/>	<input checked="" type="checkbox"/>	<input type="checkbox"/>
Antenna requirement	15.317, 15.203		<input checked="" type="checkbox"/>	<input checked="" type="checkbox"/>	<input type="checkbox"/>	<input type="checkbox"/>
Modulation techniques	15.319 (b)	6.1	<input checked="" type="checkbox"/>	<input checked="" type="checkbox"/>	<input type="checkbox"/>	<input type="checkbox"/>
Emission bandwidth	15.323 (a)	6.4	<input checked="" type="checkbox"/>	<input type="checkbox"/>	<input checked="" type="checkbox"/>	<input type="checkbox"/>
Peak Transmit Power	15.319 (c)	4.3.1; 6.5	<input checked="" type="checkbox"/>	<input type="checkbox"/>	<input checked="" type="checkbox"/>	<input type="checkbox"/>
Power spectral density	15.319 (d)	4.3.1; 6.6	<input checked="" type="checkbox"/>	<input type="checkbox"/>	<input checked="" type="checkbox"/>	<input type="checkbox"/>
Directional gain of the antenna	15.319 (e)	4.1 (e)	<input checked="" type="checkbox"/>	<input checked="" type="checkbox"/>	<input type="checkbox"/>	<input type="checkbox"/>
Automatic discontinuation of transmission	15.319 (f)	4.3.4 (a)	<input checked="" type="checkbox"/>	<input checked="" type="checkbox"/>	<input type="checkbox"/>	<input type="checkbox"/>
Radio frequency radiation exposure	15.319 (i)	RSS – 102 Gen 5.5	<input checked="" type="checkbox"/>	<input type="checkbox"/>	<input checked="" type="checkbox"/>	<input type="checkbox"/>
Monitoring threshold	15.323(c)(2); (c)(9)	4.3.4 (b)(2)	<input checked="" type="checkbox"/>	<input type="checkbox"/>	<input checked="" type="checkbox"/>	<input type="checkbox"/>
Monitoring of intended transmit window and maximum reaction time	15.323(c)(1)	4.3.4 (b)(1)	<input checked="" type="checkbox"/>	<input type="checkbox"/>	<input checked="" type="checkbox"/>	<input type="checkbox"/>
Monitoring bandwidth	15.323 (c)(7)	4.3.4 (b)(7)	<input type="checkbox"/>	<input type="checkbox"/>	<input type="checkbox"/>	<input type="checkbox"/>
Random waiting interval,	15.323 (c)(6)	4.3.4 (b)(6)	<input type="checkbox"/>	<input type="checkbox"/>	<input type="checkbox"/>	<input type="checkbox"/>
Duration of transmission,	15.323 (c)(3)	4.3.4 (b)(3)	<input checked="" type="checkbox"/>	<input type="checkbox"/>	<input checked="" type="checkbox"/>	<input type="checkbox"/>
Connection acknowledgement,	15.323 (c)(4)	4.3.4 (b)(4)	<input checked="" type="checkbox"/>	<input type="checkbox"/>	<input checked="" type="checkbox"/>	<input type="checkbox"/>
Selected channel confirmation, power accuracy, segment occupancy	15.323 (c)(5)	4.3.4 (b)(5)	<input checked="" type="checkbox"/>	<input type="checkbox"/>	<input checked="" type="checkbox"/>	<input type="checkbox"/>
Monitoring antenna,	15.323 (c)(8)	4.3.4 (b)(8)	<input checked="" type="checkbox"/>	<input checked="" type="checkbox"/>	<input type="checkbox"/>	<input type="checkbox"/>
Duplex connections	15.323 (c)(10)	4.3.4 (b)(10)	<input checked="" type="checkbox"/>	<input type="checkbox"/>	<input checked="" type="checkbox"/>	<input type="checkbox"/>
Alternative monitoring interval for co-located devices	15.323 (c)(11)	4.3.4 (b)(11)	<input checked="" type="checkbox"/>	<input checked="" type="checkbox"/>	<input type="checkbox"/>	<input type="checkbox"/>
Fair access to spectrum related to (c)(10) and (c)(11)	15.323 (c)(12)	4.3.4 (b)(12)	<input checked="" type="checkbox"/>	<input checked="" type="checkbox"/>	<input type="checkbox"/>	<input type="checkbox"/>
Emissions inside and outside the sub-band	15.323 (d)	6.7	<input checked="" type="checkbox"/>	<input type="checkbox"/>	<input checked="" type="checkbox"/>	<input type="checkbox"/>
Frame period	15.323 (e)	4.3.4 (c)	<input checked="" type="checkbox"/>	<input type="checkbox"/>	<input checked="" type="checkbox"/>	<input type="checkbox"/>
Frequency stability	15.323 (f)	6.2	<input checked="" type="checkbox"/>	<input type="checkbox"/>	<input checked="" type="checkbox"/>	<input type="checkbox"/>
Receiver spurious emissions		6.8	<input type="checkbox"/>	<input type="checkbox"/>	<input type="checkbox"/>	<input type="checkbox"/>

Test Report No.: G0M20801-0399-C-1

 Eurofins ETS Product Service GmbH
 Storkower Str. 38c, D-15526 Reichenwalde, Germany

3.1 Examinations and Test Procedures

The test procedures are performed following the requirements of FCC Part 15, RSS-213 and test standard ANSI C63.17-1998 [American National Standard for Methods of Measurement of the Electromagnetic and Operational Compatibility of Unlicensed Personal Communications Services (UPCS) Devices] and Revision Draft 3.5 ANSI-C63.17-1998 January 14, 2006 if applicable.

3.1.1 Coordination with fixed microwave service, FCC 15.307 (b)

For USA UTAM, Inc., is designated to coordinate and manage the transition of the 1910 – 1930 MHz band from Private Operational-Fixed Microwave Service (OFS) operating under Part 94 of this Chapter to unlicensed PCS operations.

Therefore each applicant for certification operating under the provisions of this Subpart must be accompanied by an affidavit from UTAM, Inc. certifying that the applicant is a participating member of UTAM, Inc.

The affidavit from UTAM Inc. is attached in Appendix B	<input checked="" type="checkbox"/>
The applicant will provide the affidavit from UTAM Inc. later in the course of certification by TCB or FCC	<input type="checkbox"/>

3.1.2 Reference to Subpart B, FCC 15.309 (b)

For USA the requirements of Subpart D apply only to the radio transmitter contained in the PCS device. Other aspects of the operation of a PCS device may be subject to requirements contained elsewhere in this Chapter. In particular, a PCS device that includes digital circuitry not direct associated with the radio transmitter also is subject to the requirements for unintentional radiators in Subpart B, For Canada unintentional radiators, other than radio receivers, are regulated by the Departments Interference Causing Equipment Standards.

Test procedures: FCC Part 15B, ICES - 003

This requirement is not applicable because the test sample does not include digital circuitry which is not direct associated with the radio transmitter	<input checked="" type="checkbox"/>
For test results according to FCC 15B and / or ICES – 003 see Appendix C	<input type="checkbox"/>
This requirement is covered by results of radiated emission test according to FCC 15.323(d) and / or RSS – 213 6.7	<input type="checkbox"/>

3.1.3 Conducted limits AC Power line, FCC 15.315, 15.207; RSS-213 4.2, 6.3 / RSS – Gen 7.2.2

For an intentional radiator which is designed to be connected to the public utility (AC) power line, the radio frequency voltage that is conducted back onto the AC line on any frequency or frequencies within the band 150 kHz to 30 MHz shall not exceed the limits in the table below. Compliance with this provision shall be based on the measurement of the radio frequency voltage between each power line and ground at the power terminals.

This measurement was transact first with instrumentation using an average and peak detector and a 10 kHz bandwidth. If the peak detector achieves a calculated level, the measurement is repeated by an instrumentation using a quasi-peak detector.

Test equipment used: ETS 0288; ETS 0474

Frequency	Level	
	quasi-peak	average
150 kHz	Lower limit line	Lower limit line

See appendix D for measurement diagrams.

Limits:

Frequency of Emission (MHz)	Conducted Limit (dB μ V)	
	Quasi Peak	Average
0.15-0.5	66 to 56	56 to 46
0.5-5	56	46
5-30	60	50

Verdict:

Pass	Fail
<input checked="" type="checkbox"/>	<input type="checkbox"/>

3.1.4 Antenna requirement, FCC 15.317, 15.203

For USA an UPCS device must meet the antenna requirement of Section 15.203.

Outcome of visual inspection:

This unit uses internal antennas. There is no provision for an external antenna.	<input checked="" type="checkbox"/>
This unit uses an unique antenna jack for connection to dedicated external antenna	<input type="checkbox"/>
This unit has an external antenna which is fix attached.	<input type="checkbox"/>
This unit with its antenna will be professionally installed as described in manufacturers description.	<input type="checkbox"/>

See Appendix A for pictures.

In this arrangement the EUT fulfils the requirements of FCC 15.203.

3.1.5 Modulation techniques, FCC 15.319 (b); RSS-213 6.1

All transmissions must use only digital modulation.

The test sample is an isochronous digital modulated device that operates in 1920-1930 MHz band. This device bases on DECT technology described in European Standards EN 300 175-2 and EN 300 175-3, now operating in frequency channels mentioned before on sub-clause 1.5.

The operating modes are MC/TDMA/TDD (Multi carrier / Time Division Multiple Access / Time Division Duplex) using Digital GFSK modulation.

For further details see operational description provided by manufacturer.

3.1.6 Emission bandwidth, FCC 15.323 (a); RSS 213 6.4

Operation will be contained within the 1920 – 1930 MHz band. The emission bandwidth shall be less than 2.5 MHz , but in no event the emission bandwidth shall be less than 50 kHz.

Emission bandwidth is measured according to ANSI 63.17 sub-clause 6.1.3 using test set-up no. 1.

$f_x = 1921.54 \text{ MHz}$			
ΔP	$f_{(low)}$	$f_{(high)}$	$\Delta f = f_{(high)} - f_{(low)}$
-26	1920.80	1922.26	1.46
-12	1920.93	1922.13	1.20
-6	1921.06	1921.97	0.91

$f_x = 1928.45 \text{ MHz}$			
ΔP	$f_{(low)}$	$f_{(high)}$	$\Delta f = f_{(high)} - f_{(low)}$
-26	1927.72	1929.17	1.45
-12	1927.88	1928.99	1.11
-6	1928.04	1928.82	0.78

See Appendix E for measurement diagrams.

Limit:

$\Delta f_{min} (-26\text{dB})$	>	50 kHz
$\Delta f_{max} (-26\text{dB})$	<	2.5 MHz

Verdict:

Pass	Fail
<input checked="" type="checkbox"/>	<input type="checkbox"/>

Test set-up 1 – General equipment configuration for conducted RF tests

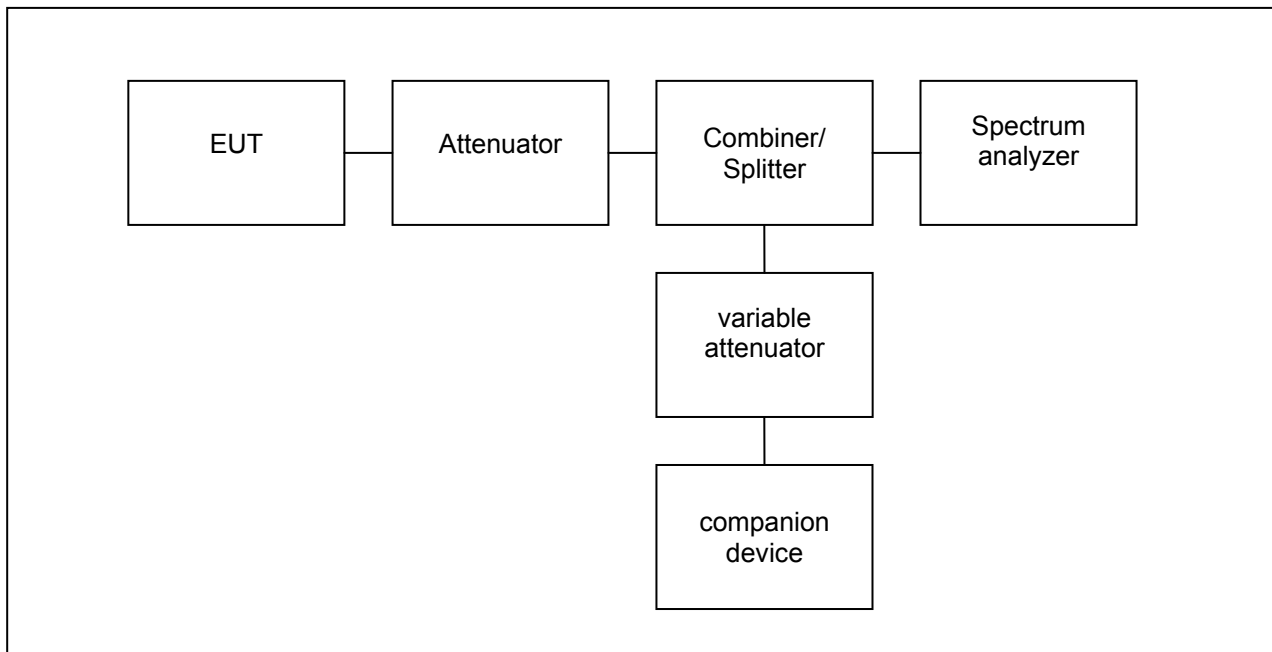

Test equipment used: ETS 0990, ETS 0492, ETS 0495, ETS 0496, ETS 0502

3.1.7 Peak transmit power, FCC 15.319 (c), FCC 15.31(e); RSS-213 4.3.1, 6.5

Peak transmit power shall not exceed 100 microwatts multiplied by the square root of the emission bandwidth in hertz. Peak transmit power must be measured over any interval of continuous transmission using instrumentation calibrated in terms of an rms-equivalent voltage. The measurement results shall be properly adjusted for any instrument limitations, such as detector response times, limited resolution bandwidth capability when compared to the emission bandwidth, sensitivity, etc., so as to obtain a true peak measurement for the emission in question over the full bandwidth of the channel.

The Peak transmit Power is measured according to ANSI 63.17 sub-clause 6.1.2. using test set-up No. 1. The limit for Peak Transmit Power has to be calculated according to following formula using the emission bandwidth measured before and the directional antenna gain.

$$\begin{aligned} \text{when } G_A \leq g \quad & \text{PTP} = 100\mu\text{W} \times \sqrt{\text{EBW}} \\ & \text{PTP} = 100\mu\text{W} \times \sqrt{\text{EBW} - (G_A - g)} \end{aligned}$$

EBW = emission bandwidth [Hz]

G_A = EUT antenna gain [dBi]

g = Allowable excess gain over that of an isotropic antenna without a transmit power reduction [$g = 3$ dB, acc. to FCC 15.319 (e)] and / or RSS-213 4.1(e)

The directional gain of used antenna has to be considered.

The test is performed with the variation of supply voltage of +/- 15% for FP. For PP a full battery is used. For devices with transmitter antenna diversity is checked that the feeding way to all antennas is identical.

Therefore one conducted PTP measurements is sufficient.

Results:

On the attached diagrams PEAK AVG represents the related measurement value determined by values in time between T1 and T2.

Frequency [MHz]	Power [dBm]		
	for U_{nom}	for U_{max}	for U_{min}
F_L	20.58	--	--
F_M	--	--	--
F_H	20.45	--	--

See Appendix F for measurement diagrams.

Limit:

EBW [MHz]	Max. power [dBm]	Corrected by antenna gain > 3 dBi
1.46	20.82	--

Verdict:

Pass	Fail
<input checked="" type="checkbox"/>	<input type="checkbox"/>

3.1.8 Power spectral density, FCC 15.319 (d); RSS-213 4.3.2.1, 6.6

Power spectral density shall not exceed 3 mW in any 3 kHz bandwidth as measured with a spectrum analyzer having a resolution bandwidth of 3 kHz.

Power spectral density is measured according to ANSI 63.17 sub-clause 6.1.5 using test set-up No. 1.

Max Hold function is applied to Max Peak detector with used sweep time as long as no changes on the curve are visible.

Results:

Frequency [MHz]	Power density [mW/3kHz]
F_L	0.8309
F_H	0.3662

See Appendix G for measurement diagrams.

Limit:

Power spectral Density	Test condition
3 mW = 4.77 dBm	3 kHz bandwidth

Verdict:

Pass	Fail
<input checked="" type="checkbox"/>	<input type="checkbox"/>

3.1.9 Directional gain of antenna, FCC 15.319 (e), RSS 213 4.1(e)

The peak transmit power shall be reduced by the amount in decibels that the maximum directional gain of the antenna exceeds 3 dBi.

Procedure: Consideration of antenna gain value provided by manufacturer or additional radiated test of Peak transmit power.

Max antenna gain [dBi]	Exceeds 3 dBi by amount [dB]
0	0

The antenna gain value is derived from:

Manufacturer declaration	<input checked="" type="checkbox"/>
Antenna diagram	<input type="checkbox"/>
Measured gain of complete system	<input type="checkbox"/>

Comment: Manufacturer declaration documents or Antenna diagrams will be considered in course of certification by responsible authority.

3.1.10 Automatic discontinuation of transmission, FCC 15.319 (f); RSS-213 4.3.4 (a)

The device shall automatically discontinue transmission in case of either absence of information to transmit or operational failure. These provisions are not intended to preclude transmission of control and signaling information or use of repetitive codes used by certain digital technologies to complete frame or burst intervals.

FP repetitive codes are allowed	<input type="checkbox"/>
PP	<input checked="" type="checkbox"/>

Automatic break off the transmission means break off of connection and break of transmissions which are not control and signaling information or receptive codes of complete frame or burst intervals. In case of devices using basics of DECT technology at least fixed parts and repeaters are using control and signaling information without direct connection to their remote station.

Evaluation		Verdict
Test according to a)	<input checked="" type="checkbox"/>	pass
Assessment of manufacturer declaration	<input type="checkbox"/>	

a) The tests are done after establishment of a connection to counter part.

	Test case	Reaction of EUT	Verdict
1	Switch – off counterpart	A	pass
2	Hook-on by counterpart	C	pass
3	Switch- off by EUT	A	pass
4	Hook -on on EUT side	B	pass
5	Remove power from EUT	A	pass
6	Remove power from counterpart	A	pass

A – Connection break down, cease of transmit

B – Connection break down, EUT transmits signaling information

C – Connection break down, counter part transmits signaling information

3.1.11 Radio frequency radiation exposure, FCC 15.319 (i); RSS-102

UPCS devices are subject to the radio frequency radiation exposure requirements specified in FCC parts 1.1307 (b), 2.1091, 2.1093 and RSS-102, as appropriate. All equipment shall be considered to operate in a "general population / uncontrolled environment. For portable devices tests according to IEEE 1528 are requested, if applicable.

Consideration of radio frequency radiation exposure for EUT is done as

SAR test acc. IEEE 1528	<input checked="" type="checkbox"/>
MPE calculation as below	<input type="checkbox"/>

SAR test results: Please see SAR test report G0M20801-0399-S-8.

MPE calculation: not applicable

The EUT is considered as a mobile device according to OET Bulletin 65, Edition – 97 – 01. Therefore distance to human body of min. 20 cm is determined.

The internal / external antennas used for this mobile transmitter must provide a separation distance of at least 20 cm from all persons and must not be co-located or operating in conjunction with any other antenna or transmitter.

A safety statement concerning minimum separation distances from enclosure of the device will be integrated in the user's manual to provide end-users with transmitter operating conditions for satisfying RFE exposure compliance.

Formula:

$$S = \text{EIRP} / 4\pi R^2 \quad (\text{EIRP} = P \cdot G)$$

Calculation:

EIRP	Radiated Power [dBm]	--
EIRP	Radiated Power [mW]	--
R	Distance [cm]	--
S	Power Density [mW/cm ²]	--

Limit:

The limit of Power density for General Population / Uncontrolled Exposure is 1.0 mW/cm². Compliance with the requirements will be considered by calculation of power density derived from radiated power value.

Verdict:

Pass	Fail
<input checked="" type="checkbox"/>	<input type="checkbox"/>

3.1.12 Monitoring threshold; Least interfered channel; FCC 15.323 (c)(2); (c)(5); (c)(9); RSS-213 4.3.4 (b)(2)

The lower monitoring threshold for EUTs without LIC procedure (least interfered channel) must not be more than 30 dB above the thermal noise power for a bandwidth equivalent to the emission bandwidth of the device.

Devices that have a power output lower than the maximum permitted under the rules can increase their monitoring detection threshold by one decibel for each one decibel that the transmitter power is below the maximum permitted.

For EUTs which support least interfered channel procedure (LIC) there is no need to measure the lower threshold because the rule 15.323(c)(2) is automatically met by the LIC procedure. For EUTs with 40 and more logical channels the upper threshold is applicable.

Monitoring threshold is measured according to Revision Draft ANSI 63.17 sub-clause 7.1, 7.2, 7.3 using test set-up No. 2.

This test set-up is used for most tests related to monitoring.

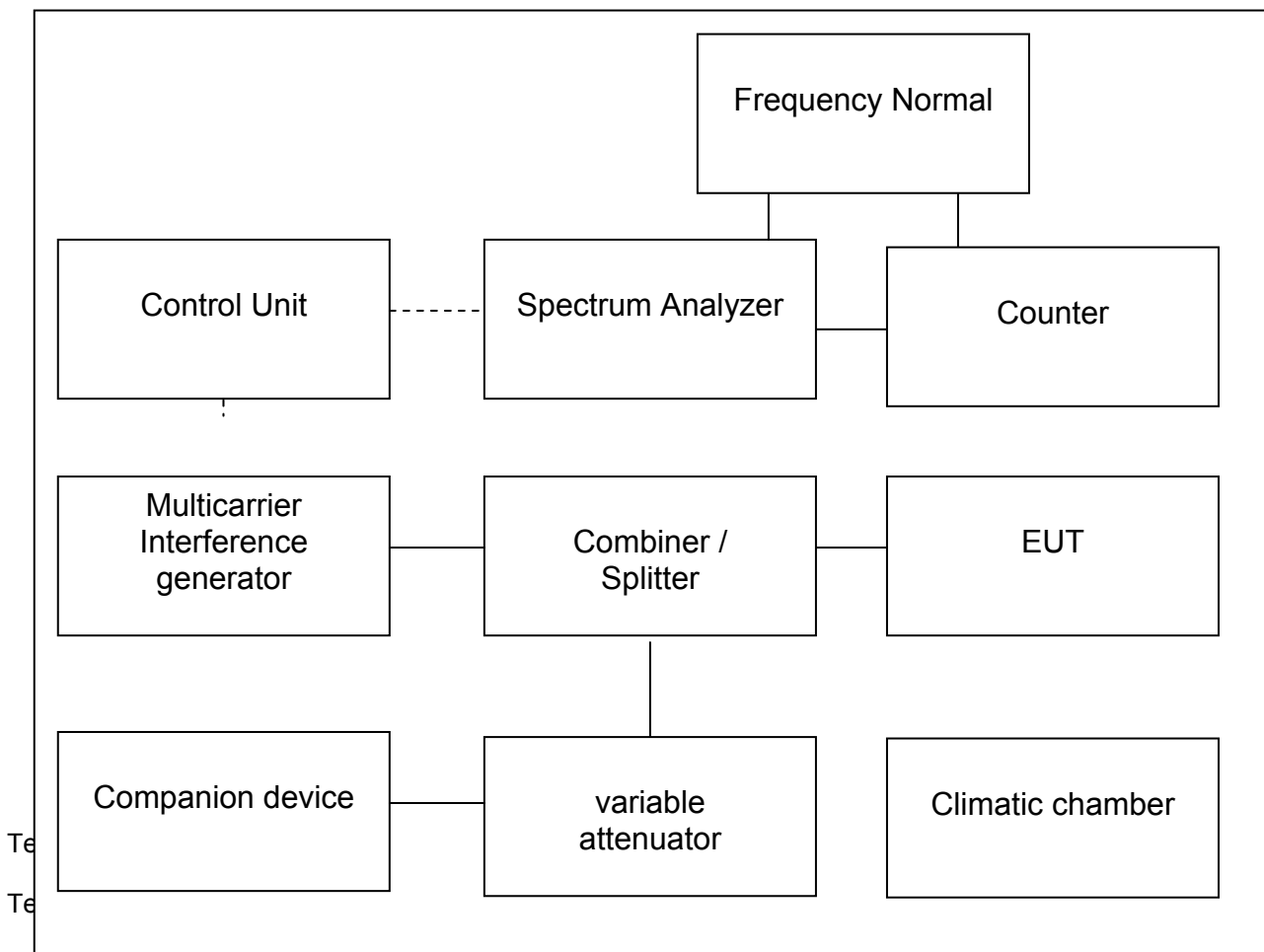

Monitoring tests generally determine the lower and upper threshold of the EUT , and verify that if the EUT is operating in the “least-interfered channel” mode, it can properly select the channel with the lowest interference power, within a 6 dB resolution. The “preferred” end of the 1920-1930 MHz band denotes the

end at which the search for channels with interference below the lower threshold shall begin. For devices with an emission bandwidth of less than 625 kHz, the search shall begin within 3 MHz , of the lower end of the band (i.e., 1920 MHz). For device with an emission bandwidth of greater than 625 kHz, the search shall begin within 3 MHz of the upper end of the band.

Calculation of monitoring threshold limits for isochronous devices:

Lower threshold:

$$T_L = 15 \log_{10}B - 184 + 30 - P \text{ (dBm)}$$

Upper threshold:

$$T_H = 15 \log_{10}B - 184 + 50 - P \text{ (dBm)}$$

B= emission bandwidth (Hz) }
 P = transmitted power (dBm) } measured values

calculated thresholds:

lower threshold [dBm]	-78.1
upper threshold [dBm]	-58.1

The upper threshold is applicable for systems which have defined a minimum of 40 duplex system access channels.

Measurement procedure:

For devices without LIC procedure:

For a not or defined interfered band the system will initiate a connection on channel with the lowest level. After that interferer level on this channel will be increased by 1dB steps, until a new connection on an other channel will established. The related interferer level represents the measured lower threshold.

For devices supporting LIC (least interferer channel) procedure:

Except of two channels (f_1 ; f_2) all other channels are blocked by interferers at levels of 26 dB above the lower limit. Then interferers apply to f_1 and f_2 with dedicated levels related to calculated lower threshold according to Revision Draft ANSI 63.17 sub-clause 7.3.3, check the behavior and repeat each test case 5 times. If the behavior is correct all times, the test is passed.

Upper threshold (for > 40 channels):

An interferer level of about 16 dB above calculated upper threshold is applicable on all system carriers. The interference level is uniformly decreased on all carriers until the EUT starts to transmit. This level is upper threshold.

Results:

Least interfered channel	Pass
Lower threshold [dBm]	n.a.
Upper threshold [dBm]	-60.0

For Log tables and / or measurement diagrams see Appendix J.

Limits:

Used results	Emission bandwidth [MHz]	1.46
	Peak transmit power [dBm]	18.23
Limits	Lower threshold [dBm] + 6 dB margin	$\leq -78.1 \dots -72.1$
	Upper threshold [dBm] + 6 dB margin	$\leq -58.1 \dots -52.1$

3.1.13 Monitoring of intended transmit window and maximum reaction time, FCC 15.323 (c)(1); RSS-213 4.3.4 (b)(1)

Immediately prior to initiating transmission, devices must monitor the combined time and spectrum window in which they intend to transmit. For a period of at least 10 milliseconds for systems designed to use a 10 millisecond or shorter frame period or at least 20 milliseconds for systems designed to use a 20 millisecond frame period.

Monitoring of intended transmit window is tested according to Revision Draft ANSI 63.7 sub-clause 7.5 using test set-up No. 2.

These tests are related to isochronous reaction time and monitoring interval.

The reaction time is the duration of the RF power, during the monitoring interval, that shall be detected by the device to determine that the monitored time and spectrum window is occupied.

The objective of the test is to demonstrate that the device defers use of a region of spectrum when the interfering signals are of a time duration that exceeds the allowed limit.

If the sample fulfills the requirements of reaction time it shows that it has monitored the intended transmit window.

Test c:

With the channel interferer level at the calculated threshold limit, plus a 6 dB margin verify that the EUT does not establish a connection when the width of the interference pulse exceeds the largest of 50 μs and $50\sqrt{1.25/B}$ μs .

B-Emission bandwidth of EUT in MHz

Test d:

With the channel interferer set to a level that is 6 dB above the calculated threshold limit, plus a 6 dB margin, verify that no connection occurs with a interference pulse width which exceeds the largest of 35 μs and $35\sqrt{1.25/B}$ μs .

Results:

Pulse width	Connection	
	F _L	F _U
50 μs or $50\sqrt{1.25/B}$ μs	no	no
35 μs or $35\sqrt{1.25/B}$ μs	no	no

For Log tables and / or measurement diagrams see Appendix K.

Verdict:

Pass	Fail
<input checked="" type="checkbox"/>	<input type="checkbox"/>

Comment:

Calculation of applied pulse width and maximum reaction time:

For Emission bandwidth > 1,25 MHz the pulse width is always 35 μ s and 50 μ s

Used results	Emission bandwidth [MHz]	e.g. 1.434
Max. reaction time and Pulse width	$50 \sqrt{1.25/B} \mu\text{s}$.	46.68
	$35 \sqrt{1.25/B} \mu\text{s}$	32.67

3.1.14 Monitoring bandwidth, Monitoring reaction time, FCC 15.323 (c)(7); RSS-213, 4.3.4 (b)(7)

Monitoring bandwidth is measured according to Revision Draft ANSI 63.17 sub-clause 7.4.1. using test set-up No. 2.

Test procedure:

Center the interfering signal at a frequency above the center of the emission of the EUT, separated by 30% of the emission bandwidth of the EUT, at a level that is 10 dB + U_M above the appropriate threshold limit. The bandwidth of the interfering signal shall be equal to or greater than the minimum emission bandwidth allowed for the sub-band. It shall be verified that the EUT does not establish a connection. The procedure is repeated with the interference centered at a frequency below the center of the emission of the EUT, separated by 30% of the emission bandwidth of the EUT, at a level that is 10 dB + U_M above the appropriate threshold limit. It shall be verified that the EUT does not establish a connection.

Results:

Interferer level [dBm]		48.1
Test frequency	Interferer frequency	Connection
F_L	F_L - 30 % BW	no
	F_L + 30 % BW	no
F_U	F_U - 30% BW	no
	F_U + 30 % BW	no

For examples of log tables and / or measurement diagrams see Appendix L.

Verdict:

Pass	Fail
<input checked="" type="checkbox"/>	<input type="checkbox"/>

3.1.15 Random waiting interval, FCC 15.323 (c)(6); RSS-213, 4.3.4 (b)(6)

If the selected combined time and spectrum windows are unavailable, the device may either monitor and select different windows or seek to use the same window after waiting an amount of time, randomly chosen from a uniform random distribution between 10 and 150 milliseconds, commencing when the channel becomes available.

Random waiting interval is considered according ANSI 63.17 sub-clause 8.1.3.

This test applies to an EUT capable of transmitting control and signaling information on its own without companion device.

It is measured the time interval between the end of the EUT transmission and the beginning of transmission by the EUT in the same time and spectrum window..

Test set-up No. 1 is used.

Comment: This test is not applicable for this EUT.

Test procedure: ANSI 63.17 Sub-clause 8.1

3.1.16 Duration of Transmission, FCC 15.323 (c)(3); RSS-213 4.3.4 (b)(3)

If no signal above the threshold level is detected, transmission may commence and continue with the same emission bandwidth in the monitored time and spectrum windows without further monitoring. However, occupation of the same combined time and spectrum window by a device or group of cooperating devices continuously over a period of time longer than 8 hours is not permitted without repeating the access criteria.

Duration of Transmission (Maximum transmit period) is measured according to Revision Draft ANSI 63.17 sub-clause 8.2.2 using test set-up No. 1.

Comment: For DECT based technology the PP is the initiating device and determines duration of transmission. The fix part follows the portable part.

Result:

Maximum transmission time	3 h 15 min
---------------------------	------------

For examples of log tables and / or measurement diagrams see Appendix N:

Limit:

Maximum transmission time [h]	< 8
-------------------------------	-----

Verdict:

Pass	Fail
<input checked="" type="checkbox"/>	<input type="checkbox"/>

3.1.17 Connection acknowledgements, Unacknowledged transmissions FCC 15.323 (c)(4); RSS-213 4.3.4 (b)(4)

Once access to specific combined time and spectrum windows is obtained an acknowledgement from a system participant must be received by the initiating transmitter within one second or transmission must cease. Periodic acknowledgements must be received at least every 30 seconds or transmission must cease. Channels used exclusively for control and signaling information may transmit continuously for 30 seconds without receiving an acknowledgement, at which time the access criteria must be repeated.

Connection acknowledgements are tested according to Revision Draft ANSI 63.17 sub-clause 8.2.1, Unacknowledged transmission following sub clause 8.1.1. Access criteria test interval and 8.1.2 Access criteria functional test. subclause 8.1.3 Access criteria functional test is not applicable because option FCC 15.323 (c)(6) /RSS-213 4.3.4 (b)(6) is not implemented.

Unacknowledged transmission:

Results:

Requirement	Time	Verdict
Access criteria test interval (8.1.1)	--	n.a.
Access criteria functional test (8.1.2)	--	n.a.

Limits:

Requirement	Value
Access criteria test interval (8.1.1)	≤ 30 s
Access criteria functional test (8.1.2)	mandatory

Connection acknowledgement

Results:

Requirement	Time	Verdict
Connection acknowledgement [8.2.1 (a)(b)] PP only	822 ms	pass
Termination of transmission [8.2.1 (c)]	3.41 s	pass

Limits:

Requirement	Value
Connection acknowledgement [8.2.1 (a)(b)] PP only	≤ 1 s
Termination of transmission [8.2.1 (c)]	≤ 30 s

For LOG tables see Appendix O.

3.1.18 Selected channel confirmation, segment occupancy, FCC 15.323 (c)(5); RSS-213 4.3.4 (b)(5)

If a minimum of 40 duplex system access channels are defined, the system must have monitored all access channels defined for its system within the last 10 seconds and must verify, within the 20 milliseconds (40 milliseconds for devices designed to use a 20 milliseconds frame period) immediately preceding actual channel access that the detected power of the selected time and spectrum windows is no higher than the previously detected value.

The power measurement resolution for this comparison must be accurate within 6 dB.

No device or group of co-operating devices located within 1 meter of each other shall during any frame period occupy more than 6 MHz of aggregate bandwidth, or alternatively, more than one third of the time and spectrum windows defined by the system.

Selected channel confirmation:

This test is done according to Revision Draft ANSI 63.17 sub-clause 7.3.4 using test set-up No. 2.

Results:

Test	Transmit on f_1	Transmit on f_2	Verdict
c	yes	no	pass

Power accuracy

The power measurement resolution for the previous comparisons must be accurate to within 6 dB.

This requirement was proved automatically by testing of monitoring thresholds according to FCC 15.323 (c)(2); RSS-213 4.3.4 (b)(2), see 2.4.12.

Segment occupancy

Document	available	sufficient
Manufacturers declaration	<input checked="" type="checkbox"/>	<input checked="" type="checkbox"/>
Technical description	<input type="checkbox"/>	<input type="checkbox"/>

See attached diagrams in Appendix P.

3.1.19 Monitoring antenna, FCC 15.323 (c)(8); RSS-213 4.3.4 (b)(8)

The monitoring system shall use the same antenna used for transmission, or an antenna that yields equivalent reception at that location.

The monitoring system shall use the same antenna used for transmission or an antenna that yields equivalent reception at that location.

System uses same antenna(s)	<input checked="" type="checkbox"/>
System uses different antenna(s)	<input type="checkbox"/>

If the monitoring antenna is different from the transmitting antenna, it shall be verified that the monitoring antenna provides coverage equivalent to that of the transmitting antenna.

The related tests are to perform according to Revision Draft ANSI 63.17 sub-clause 4.5 using test set-up No. 3.

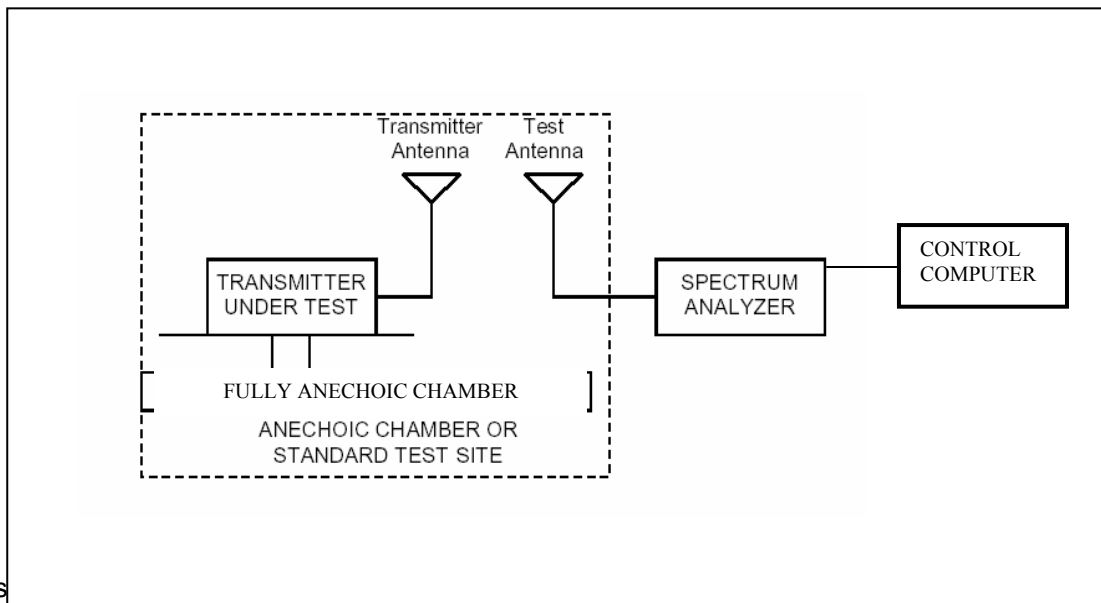

Test equipment used: ETS 0012, ETS 0013, ETS 0014, ETS 0031, ETS 0253, ETS 0310

3.1.20 Duplex connections, FCC 15.323 (c)(10); RSS-213 4.3.4 (b)(10)

An initiating device may attempt to establish a duplex connection by monitoring both its intended transmit and receive time spectrum windows. If both the intended transmit and receive time and spectrum window meet the access criteria, then the initiating device can initiate a transmission in the intended transmit time and spectrum window. If the power detected by the responding device can be decoded as a duplex connection signal from the initiating device, then the responding device may immediately begin transmitting on the receive time and spectrum window monitored by the initiating device.

This test verifies that the two devices communicating over a duplex connection comply with the access criteria. The Initiating device is the EUT, the responding device is the companion device tested in conjunction with the EUT.

The EUT is a responding device Therefore these tests are not applicable	<input type="checkbox"/>
The EUT do not implement upper threshold. ANSI 63.17 8.3.1 is applicable	<input type="checkbox"/>
The EUT implements upper threshold. ANSI 63.17 8.3.2 is applicable	<input checked="" type="checkbox"/>

Tests according to subclause 8.3.1 “Validation of dual access criteria check for EUTs which do not implement the upper threshold”:

Test b)

The test proves the basic conditions for the following tests. The out-of-operating-region interference is used to confine the EUT to the band.

Test c) and d)

These tests proves whether a connection can be established with interferences levels of $T_L + U_M$ on all if its receive time/spectrum windows except one which is interference free.

Apply interference at $T_L + U_M$ on all transmit time/spectrum windows of the EUT.

If a connection is established the test fails.

Test e) and f)

These tests proves whether a connection can be established with interferences levels of $T_L + U_M$ on all if its transmit time/spectrum windows except one which is interference free.

Apply interference at $T_L + U_M$ on all receive time/spectrum windows of the EUT.

If a connection is established the test fails.

Tests according to subclause 8.3.2 “Validation of dual access criteria check for EUTs which implement the upper threshold”:

Test b)

The test proves the basic conditions for the following tests. The out-of-operating-region interference is used to confine the EUT to the band.

Test c) and d)

Apply interferences of $T_L + U_M$ to the EUT on the EUTs transmit time/ spectrum windows except for one which is free of interferences. Apply interferences of $T_L + U_M + 7$ dB to the receive time/spectrum windows except for one which is free of interferences. The interference-free receive time/spectrum window must not be the duplex mate of the interference-free transmit time/spectrum window. The connection should be made on the interference-free time/spectrum window and its duplex mate.

Test e) and f)

Apply interferences of $T_L + U_M$ to the EUT on the EUTs receive time/spectrum windows except one which is free of interferences. Apply interferences of $T_L + U_M + 7$ dB to the transmit time/spectrum windows except one which is free of interferences. The interference-free time/spectrum windows should not constitute a duplex pair.

The connection should be made on the interference free transmit time/spectrum window and its duplex mate.

Test g)

Raise the interferences to the EUT on all of the EUTs transmit and receive time/spectrum windows to $T_U + U_M$ except for a single transmit time/spectrum window and a single transmit time/spectrum window and a single receive time/spectrum window which shall have low interference levels.

These low-interference level time/spectrum windows shall not constitute a duplex pair. If the EUT transmits or a connection is established, the test is failed.

Test		applicable	Connection	No connection	verdict
8.3.1	c) and d)	<input type="checkbox"/>	<input type="checkbox"/>	<input type="checkbox"/>	n.a.
	e) and f)	<input type="checkbox"/>	<input type="checkbox"/>	<input type="checkbox"/>	n.a.
8.3.2	c) and d)	<input checked="" type="checkbox"/>	<input checked="" type="checkbox"/>	<input type="checkbox"/>	pass
	e) and f)	<input checked="" type="checkbox"/>	<input checked="" type="checkbox"/>	<input type="checkbox"/>	pass
	g)	<input checked="" type="checkbox"/>	<input type="checkbox"/>	<input checked="" type="checkbox"/>	pass

Comment: For DECT based technology the PP is the initiating device and determines duplex connections.

The fix part is the responding device and follows the initiating device in its functions.

3.1.21 Alternative monitoring interval for co-located devices, FCC 15.323 (c)(11); RSS–213 4.3.4 (b)(11)

An initiating device that is prevented from monitoring during its intended transmit window due to monitoring system blocking from the transmissions of a co-located (within one meter) transmitter of the same system, may monitor the portions of the time and spectrum windows in which they intend to receive over a period of at least 10 milliseconds. The monitored time and spectrum window must total at least 50 percent of the 10 millisecond frame interval and the monitored spectrum must be within 1.25 MHz of the center frequency of channel(s) already occupied by that device or co-located co-operating device. If the access criteria is met for the intended receive time and spectrum window under the above conditions, then transmission in the intended transmit window by the initiating device may commence.

Alternative monitoring interval for co-located devices may be tested according Revision Draft ANSI 63.17 sub-clause 8.4 using test set-up No. 2.

Results.

The manufacturer declares that this provision is not utilized by the EUT.

3.1.22 Fair access to spectrum related to (c)(10) and (c)(11), FCC 15.323 (c)(12); RSS–213 4.3.4 (b)(12)

The provisions of FCC 15.323 (c)(10) or (c)(11) and RSS–213 4.3.4 (b)(10) or (11) shall not be used to extend the range of spectrum occupied over space or time for the purpose of denying fair access to spectrum for other devices.

The manufacturer declares that is device does not work in a mode which denies fair access to spectrum for other participants.

3.1.23 Emissions inside and outside the sub-bands, FCC 15.323 (d); RSS-213 6.7

Emissions outside the sub-bands shall be attenuated below a reference power of 112 milliwatts as follows: 30 dB between the sub-band and 1.25 MHz above or below the sub-band, (-9.5 dBm); 50 dB between 1.25 and 2.5 MHz above or below the sub-band, (-29,5 dBm); and 60 dB at 2.5 MHz or greater above or below the sub-band, (-39.5 dBm)

Emissions inside the sub-band must comply with the following emission mask: In the bands between 1B and 2B ("B" is defined as the emission bandwidth of the device in hertz) measured from the center of the emission bandwidth the total power emitted by the device shall be at least 50 dB below the transmit power permitted for that radiator; in the bands between 3B and the sub-band edge the total power emitted by an intentional radiator in the measurement bandwidth shall be at least 60 dB below the transmit power permitted for that radiator.

Compliance with the emission limits is based on the use of measurement instrumentation employing peak detector function with an instrument resolution bandwidth approximately equal to 1.0 percent of the emission bandwidth of the device under measurement.

Emission inside and outside the sub-band are tested according to ANSI 63.17 sub-clauses 6.1.6.1 and 6.1.6.2.

Determination of measurement bandwidth:

$$BT_T = \text{approx. } 1\% \text{ of } B$$

Used results	Emission bandwidth [MHz]	1.46
Calculated value	Resolution bandwidth [kHz]	14.6
Determined value	Resolution bandwidth [kHz]	10

Emissions inside the sub-band

Testing of emissions inside the sub-band are performed using test set-up No.1. The applied emission mask limit was created using the current emission bandwidth.

For results see diagrams in Appendix R.

Emissions outside the sub-band

Out of sub band emissions are tested as radiated measurement bandwidth of about 1% of emission bandwidth near the band edges and at critical frequencies where the measurement values come near the limits. For practical reasons other frequencies the more stringent bandwidth of 100 kHz is used.

As test environment serves a fully anechoic chamber providing a free space environment (test set-up No. 3)

All results will be updated by an automatic measuring system in accordance with point 2.3.

Calculation of test results:

Such factors like antenna correction, cable loss, external attenuation etc. are already included in the provided measurement results. This is done by using validated test software and calibrated test system according the accreditation requirements.

The significant peak and average values are listed in the tables below showing the compliance with the above calculated limits. For frequency ranges with measurement value far below the limits no measurement diagrams are shown.

Summary table with radiated data of the test plots

Freq.	Used Ch.	Frequency Marker [GHz]	Polarization	Δ corrections dB	Max. Power level [dBm]	Compliance Limit [dBm]	Detector	BW [kHz]	Margin [dB]

Freq. – Frequency Range:

- 1: 30 – 200 MHz
- 2: 200 – 1000 MHz
- 3: 1 – 4 GHz
- 4: 4 – 8 GHz
- 5: 8 – 12 GHz
- 6: 12 – 17 GHz
- 7: 17 – 26.5 GHz

For results see diagrams in Appendix R.

Limits:

For spectrum mask and limit lines see diagrams.

Verdict:

Pass	Fail
<input checked="" type="checkbox"/>	<input type="checkbox"/>

3.1.24 Frame period, FCC 15.323 (e); RSS-213 4.3.4 (c)

The frame period (a set of consecutive time slots in which the position of each time slot can be identified by reference to a synchronizing source) of an intentional radiator operating in these subbands shall be 20 milliseconds/X where x is a positive whole number. Each device that implements time division for the purposes of maintaining a duplex connection on a given frequency carrier shall maintain a frame repetition rate with a frequency stability of at least 50 parts per millions (ppm). Each devices which further divides access in time in order to support multiple communication links on a given frequency carrier shall maintain a frame repetition rate with a frequency stability of at least 10 ppm. The jitter (time-related, abrupt, spurious variations in the duration of the frame interval) introduced at the two ends of such a communication link shall not exceed 25 microseconds for any two consecutive transmissions. Transmissions shall be continuous in every time and spectrum window during the frame period defined for the device.

Frame repetition stability is tested according to Revision Draft ANSI 63.17 sub-clause 6.2.2. Frame period and jitter are tested following sub-clause 6.2.3. For all measurements test set-up No.1 is used.

Frame repetition stability:

The spectrum analyzer is used as an envelope detector and provides gating signals to a frequency counter. The obtained frequency values are computed to get mean value, deviation and frame repetition stability. Frame repetition stability is three times of the standard deviation SD.

Results:

Frequency (MHz)	Standard Deviation	Mean(Hz)	3 x SD (ppm)
1924.992	0.000005	99.999935	0.082860

Limits:

Time division mode	Frame repetition stability	applicable
TDA	50 ppm	<input type="checkbox"/>
TDMA	10 ppm	<input checked="" type="checkbox"/>

Verdict:

Pass	Fail
<input checked="" type="checkbox"/>	<input type="checkbox"/>

Frame period and jitter:

Frame period and jitter test the spectrum and modulation is used to obtain the time duration between rising edges. These measurement value are used to compute the difference between any two consecutive frame periods (jitter).

The measured mean time is the frame period.

Results:

Frequency (MHz)	Mean (ms)	Deviation (Hz)	Peak to Peak (µs)
1924.992	9.999350	0.000012	0.070781

For examples of measurements sheets see Appendix S.

Limits:

Frame period [ms]	20 or 10/x
Max. jitter [µs]	25
3 times the standard deviation SD [µs] value of jitter ²⁾	12.5

²⁾ This item is not required by FCC 15.323(e).

Verdict:

Pass	Fail
<input checked="" type="checkbox"/>	<input type="checkbox"/>

3.1.25 Frequency stability, FCC 15.323 (f); RSS – 213 6.2

The frequency stability of the carrier frequency of the intentional radiator shall be maintained within ± 10 ppm over 1 hour or the interval between channel access monitoring, whichever is shorter. The frequency stability shall be maintained over a temperature variation of -20° to $+50^{\circ}$ degrees C at normal supply voltage, and over a variation in the primary supply voltage of 85 percent to 115 percent of the rated supply voltage at a temperature of 20° C. For equipment that is capable only of operating from a battery, the frequency stability tests shall be performed using a new battery without any further requirements to vary supply voltage.

Frequency stability is measured by spectrum analyzer in modulation mode according to Revision Draft ANSI 63.17 sub-clause 6.2.1.

The procedure is carried out with conditions shown in result table below, where the first row shows the carrier frequency stability over time.

Results:

Temp °C	Supply Voltage	Frequency of carrier (MHz)	Stability over time f_{max} (ppm)	Stability over time f_{min} (ppm)	Mean (MHz)	Stability (ppm)
25	Vnom	1924.9922	2.66	2.19	1924.992249	Reference
55	Vnom	1924.992854	3,24	4,31	1924.988471	2,28
-10	Vnom	1924.992854	1.95	6.31	1925.005126	-6.37

Limit : 10 ppm

$$Deviation \text{ ppm} = \frac{FR - FM}{FR} * 10^6 \quad 69$$

FR = Reference frequency of carrier at 20° C and V_{nom}

FM = Measured frequency of carrier

For histograms see Appendix T.

Limit:

Temperature [°C]	Supply voltage	Frequency deviation [ppm]
25	85-115% or new batteries	Reference
-25	Normal	10
+50	Normal	10
Others ¹⁾ -10	Normal	10
Others ¹⁾ +55	Normal	10

¹⁾ declared by manufacturer

Verdict:

Pass	Fail
<input checked="" type="checkbox"/>	<input type="checkbox"/>

3.1.26 Receiver spurious emissions, RSS-213 6.8

Receiver spurious emissions shall comply with the limits specified in RSS-Gen.

For radiated measurements the resolution bandwidth of the spectrum analyzer shall be 100 kHz for spurious emissions below 1 GHz and 1 MHz above 1 GHz. For emissions below 1 GHz a CISPR quasi peak demodulator is used. Above 1 GHz an average detector is used.

The receiver operating frequency shall be putted to the middle of the band for this test.

Results:

Device Frequency	Frequency marker indication [MHz]	Antenna polarization	Worst case emission level [$\mu\text{V/m}$]	Compliance limit [$\mu\text{V/m}$]	Results [$\mu\text{V/m}$]
2441 MHz	198,300	V	28,39	150	<u>-123,73</u>
	191,311	H	28,36	150	<u>-123,82</u>
	713,778	V	23,18	200	<u>-185,58</u>
	942,222	H	22,14	200	<u>-187,21</u>
	3977,000	V	44,14	500	<u>-338,94</u>
	3670,000	H	43,3	500	<u>-353,78</u>
	7689,000	V	42,4	150	<u>-123,73</u>
	7418,000	H	43,28	150	<u>-123,82</u>

Freq. – Frequency Range:

- 1: 30 – 200 MHz
- 2: 200 – 1000 MHz
- 3: 1 – 4 GHz
- 4: 4 – 8 GHz

For results see diagrams in Appendix U.

Limit:

Spurious Frequency (MHz)	Field Strength (microvolt/m at 3 metres)	dB $\mu\text{V/m}$
30 – 88	100	40
88 – 216	150	43.5
216 – 960	200	46
Above 960	500	54

Verdict:

Pass	Fail
<input checked="" type="checkbox"/>	<input type="checkbox"/>

Appendix

A	Pictures
B	Coordination with fixed microwave service
C	Conducted limits AC Power line
D	Emission bandwidth
E	Peak Transmit Power
F	Power spectral density
G	Radio frequency radiation exposure
H	Monitoring threshold
I	Monitoring of intended transmit window and maximum reaction time
J	Monitoring bandwidth
K	Duration of Transmission
L	Connection acknowledgement
M	Selected channel, power accuracy, segment occupancy
N	Duplex connections
O	Emissions inside and outside the sub-band
P	Frame period
Q	Frequency stability
R	Receiver spurious emissions