

ELECTRONIC TECHNOLOGY SYSTEMS  
DR. GENZ GMBH

# TEST - REPORT

FCC PART 15 for Isochronous UPCS devices

FCC ID: PXAPP3N-1G9

Test report no.:

G0M20505-9482-C-2



Certificate 1983-01

## TABLE OF CONTENTS

### **1 General information**

- 1.1 Notes
- 1.2 Testing laboratory
- 1.3 Details of approval holder
- 1.4 Application details
- 1.5 Test item
- 1.6 Test standards

### **2 TECHNICAL TEST**

- 2.1 Summary of test results
- 2.2 Test environment
- 2.3 Test equipment utilized
- 2.4 Examinations and Test Procedures
  - 2.4.1 Coordination with fixed microwave service, FCC 15.307 (b)
  - 2.4.2 Reference to Subpart B, FCC 15.309 (b)
  - 2.4.3 Labeling requirements, FCC 15.311,15.19(a)(3)
  - 2.4.4 Conducted limits AC Power line, FCC 15.315 , 15.207
  - 2.4.5 Antenna requirement, FCC 15.317, 15.203
  - 2.4.6 Modulation techniques, FCC 15.319 (b)
  - 2.4.7 Emission band width, FCC 15.323 (a); FCC 15.31 (e)
  - 2.4.8 Peak Transmit Power, FCC 15.319 (c)
  - 2.4.9 Power spectral density, FCC 15.319 (d)
  - 2.4.10 Directional gain of the antenna, FCC 15.319 (e)
  - 2.4.11 Automatic discontinuation of transmission, FCC 15.319 (f)
  - 2.4.12 Radio frequency radiation exposure, FCC 15.319 (i)
  - 2.4.13 Monitoring threshold; Least interfered channel; FCC 15.323 (c)(2); (c)(5) (c)(9)
  - 2.4.14 Monitoring of intended transmit window and maximum reaction time, FCC 15.323 (c)(1)
  - 2.4.15 Monitoring band width, FCC 15.323 (c)(7)
  - 2.4.16 Random waiting interval, FCC 15.323 (c)(6)
  - 2.4.17 Duration of transmission, FCC 15.323 (c)(3)
  - 2.4.18 Connection acknowledgement, Unacknowledged transmissions, FCC 15.323 (c)(4)
  - 2.4.19 Selected channel confirmation, Power accuracy, Segment occupancy; FCC 15.323 (c)(5)
  - 2.4.20 Monitoring antenna, FCC 15.323 (c)(8)
  - 2.4.21 Duplex connections, FCC 15.323 (c)(10)
  - 2.4.22 Alternative monitoring interval for co-located devices, FCC 15.323 (c)(11)
  - 2.4.23 Fair access to spectrum related to (c)(10) and (c)(11), FCC 15.323 (c)(12)
  - 2.4.24 Emissions inside and outside the sub-band, FCC 15.323 (d)
  - 2.4.25 Frame period, FCC 323 (e)
  - 2.4.26 Frequency stability, FCC 323 (f)

### 3 RESULTS OF EXAMINATIONS AND TESTS

- 3.1 Coordination with fixed microwave service, FCC 15.307 (b)
- 3.2 Reference to Subpart B, FCC 15.309 (b)
- 3.3 Labeling requirements, FCC 15.311, 15.19(a)(3)
- 3.4 Conducted limits AC Power line, FCC 15.315 , 15.207
- 3.5 Antenna requirement, FCC 15.317, 15.203
- 3.6 Modulation techniques, FCC 15.319 (b)
- 3.7 Emission band width, FCC 15.323 (a)
- 3.8 Peak Transmit Power, FCC 15.319 (c); FCC 15.31 (e)
- 3.9 Power spectral density, FCC 15.319 (d)
- 3.10 Directional gain of the antenna, FCC 15.319 (e)
- 3.11 Automatic discontinuation of transmission, FCC 15.319 (f)
- 3.12 Radio frequency radiation exposure, FCC 15.319 (i)
- 3.13 Monitoring threshold , FCC 15.323 (c)(2); (c)(9)
- 3.14 Monitoring of intended transmit window and maximum reaction time,  
FCC 15.323 (c)(1)
- 3.15 Monitoring band width, FCC 15.323 (c)(7)
- 3.16 Random waiting interval, FCC 15.323 (c)(6)
- 3.17 Duration of transmission, FCC 15.323 (c)(3)
- 3.18 Connection acknowledgement, Unacknowledged transmissions FCC 15.323 (c)(4)
- 3.19 Selected channel confirmation, Power accuracy, Segment occupancy;  
FCC 15.323 (c)(5)
- 3.20 Monitoring antenna, FCC 15.323 (c)(8)
- 3.21 Duplex connections, FCC 15.323 (c)(10)
- 3.22 Alternative monitoring interval for co-located devices, FCC 15.323 (c)(11)
- 3.23 Fair access to spectrum related to (c)(10) and (c)(11), FCC 15.323 (c)(12)
- 3.24 Emissions inside and outside the sub-band, FCC 15.323 (d)
- 3.25 Frame period, FCC 323 (e)
- 3.26 Frequency stability, FCC 323 (f)

# 1 General Information

## 1.1 Notes

The purpose of conformity testing is to increase the probability of adherence to the essential requirements or conformity specifications, as appropriate.

The complexity of the technical specifications, however, means that full and thorough testing is impractical for both technical and economic reasons.

Furthermore, there is no guarantee that a test sample which has Passed all the relevant tests conforms to a specification.

Neither is there any guarantee that such a test sample will interoperate with other genuinely open systems.

The existence of the tests nevertheless provides the confidence that the test sample possesses the qualities as maintained and that its performance generally conforms to representative cases of communications equipment.

The test results of this test report relate exclusively to the item tested as specified in 1.5.

The test report may only be reproduced or published in full.

Reproduction or publication of extracts from the report requires the prior written approval of the ELECTRONIC TECHNOLOGY SYSTEMS DR. GENZ GMBH.

### Specific Conditions:

Usage of the hereunder tested device in combination with other integrated or external antennas requires at least additional output power measurements, spurious emission measurements, conducted emission measurements (AC supply lines) and radio frequency exposure evaluations for each individual configuration are performed, for certification by FCC.

This report is related to FCC Part 15 D applied to UPCS devices of which technology is derived from DECT standard.

### Tester:

|            |  |            |  |
|------------|--|------------|--|
| 02.09.2005 |  | W. Treffke | <i>i.s. Kuv</i>  |
|------------|--|------------|--|

|      |          |      |           |
|------|----------|------|-----------|
| Date | ETS-Lab. | Name | Signature |
|------|----------|------|-----------|

### Technical responsibility for area of testing:

|            |  |           |  |
|------------|--|-----------|--|
| 02.09.2005 |  | N. Kaspar |  |
|------------|--|-----------|--|

|      |     |      |           |
|------|-----|------|-----------|
| Date | ETS | Name | Signature |
|------|-----|------|-----------|

## 1.2 Testing laboratory

### 1.2.1 Location

ELECTRONIC TECHNOLOGY SYSTEM DR. GENZ GMBH (ETS)  
Storkower Straße 38c  
D-15526 Reichenwalde b. Berlin  
Germany  
Telefon : +49 33631 888 00  
Telefax : +49 33631 888 66

### 1.2.2 Details of accreditation status

**ACCREDITED TESTING LABORATORY**  
**DAR-REGISTRATION NUMBER:** TTI-P-G 126/96

**ACCREDITED COMPETENT BODY**  
**DAR-REGISTRATION NUMBER:** BPT-ZE-026/96

**FCC FILED TEST LABORATORY** REG. NO. 96970

**Bluetooth Qualification Test Facility (BQTF)**  
Accredited by Bluetooth Qualification Review Board (BQRF)

**INDUSTRY CANADA FILED TEST LABORATORY** REG. NO. IC 3470

**A2LA ACCREDITED** Certificate Number: 1983-01

## 1.3 Details of approval holder

Name : KIRK telecom A/S  
Street : Langmarksvej 34  
Town : DK-8700 Horsens  
Country : Denmark  
Telephone : +45 7628 1280  
Fax : +45 7560 2851  
  
Contact : Mr. Henrik Birch Rasmussen  
Telephone : +45 7628 1280  
E-mail : hbr@kirktelecom.dk

## 1.4 Application details

Date of receipt of application : 09.05.2005  
 Date of receipt of test item : 09.05.2005  
 Date of test : 09.05.2005 – 31.08.2005

## 1.5 Test item

Description of test item : Isochronous UPCS device, cordless phone based on DECT modified technology.

| Function      |                                     |
|---------------|-------------------------------------|
| Portable part | <input checked="" type="checkbox"/> |
| Base station  |                                     |
| Repeater      |                                     |

Description of test item : KIRK UPCS (DECT based) Handset (PP)  
 Type identification : PP3N 1G9  
 Portable part  
 Brand Name : Kirk telecom A/S  
 Serial number : Test model without serial number.  
 Photos : See annex

### Technical data

Frequency bands : 1920 – 1930 MHz

| Operating Channel numbers | Test Frequencies | Channel center frequency (MHz) |
|---------------------------|------------------|--------------------------------|
| -14                       | F <sub>L</sub>   | 1921.54                        |
| -15                       |                  | 1923.26                        |
| -16                       | F <sub>M</sub>   | 1924.99                        |
| -17                       |                  | 1926.72                        |
| -18                       | F <sub>U</sub>   | 1928.45                        |

Number of channels : 60 (in time and spectrum window, declared by manufacturer)  
 Operating modes : MC / TDMA / TDD  
 Type of modulation : GFSK  
 Max. slot type:

|             |                                     |
|-------------|-------------------------------------|
| single slot | <input checked="" type="checkbox"/> |
| double slot | <input type="checkbox"/>            |

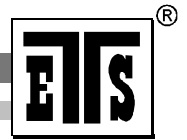

Fixed point-to-point operation: Yes/No

| Antenna | Type     | Gain [dBi] | internal                            | external                 |
|---------|----------|------------|-------------------------------------|--------------------------|
| 1       | Monopole | 2          | <input checked="" type="checkbox"/> | <input type="checkbox"/> |

Antenna connector : n.a.

Antenna diversity :

| Antenna | Diversity supported      |                          |
|---------|--------------------------|--------------------------|
|         | Tx                       | Rx                       |
| 1       | <input type="checkbox"/> | <input type="checkbox"/> |
| 2       | <input type="checkbox"/> | <input type="checkbox"/> |

Host device : none

Classification : related to radio frequency radiation exposure

|  |                                     |
|--|-------------------------------------|
| Fixed Device                                 | <input type="checkbox"/>            |
| Mobile Device (Human Body distance > 20cm)   | <input type="checkbox"/>            |
| Portable Device (Human Body distance < 20cm) | <input checked="" type="checkbox"/> |

Power supply : 3.6 V DC

Type of power supply : Battery; charger: Desk Stand (84642447)

Data connection :

| Connection    | used                                |
|---------------|-------------------------------------|
| None          | <input checked="" type="checkbox"/> |
| PSTN          | <input type="checkbox"/>            |
| Data Networks | <input type="checkbox"/>            |
| others        | <input type="checkbox"/>            |

Remark: Devices intended to be connected to PSTN have to be applied for FCC PART 68 registration.

**Manufacturer:**  
(if applicable)

Name :  
Street :  
Town :  
Country :

**1.6 Test standards**

Technical standard : FCC PART 15, Subpart D

Test method and procedure: Following requirements of FCC Part 15 D and ANSI C63.17-1998 / (Revision Draft ANSI-C63.17-1998 Febr. 1, 2005 if applicable.)

Additional information : The row scheme for frequency generation, radio channels, receiver parameters, synchronization procedure, and other parameters are determined by the DECT standard. Details are content of operational description provided by manufacturer.



## 2 Technical test

### 2.1 Summary of test results

No deviations from the technical specification(s) were ascertained in the course of the tests performed.



or

The deviations as specified in 2.5 were ascertained in the course of the tests performed.



### 2.2 Test environment

Temperature : 25°C

Relative humidity content : 20 ... 75 %

Air pressure : 86 ... 103 kPa

Details of power supply : 3.6 V DC battery

Extreme conditions parameters: : test voltage - extreme min : 3.24 V, DC  
(manufacturer declaration) max: 4.5 V, DC

temperatures – extreme min: -10°C <sup>1)</sup>  
max: +55°C <sup>1)</sup>

Remarks: <sup>1)</sup> declared by manufacturer

## 2.3 Test equipment utilized

| No.      | Test equipment                | Type                 | Manufacturer     |
|----------|-------------------------------|----------------------|------------------|
| ETS 0001 | ESD Gun                       | SESD 30000           | Schlöder         |
| ETS 0002 | Test receiver                 | ESVP                 | Rohde & Schwarz  |
| ETS 0003 | Diode power sensor            | NRV-Z2               | Rohde & Schwarz  |
| ETS 0004 | Spectrum and network analyzer | FSMS 26              | Rohde & Schwarz  |
| ETS 0005 | Test receiver                 | SMV 11               | MEB              |
| ETS 0006 | Test receiver system          | SME 12               | MEB              |
| ETS 0007 | Horn antenna                  | AT 4004              | ar               |
| ETS 0008 | Antenna                       | Loop antenna         | Siemens          |
| ETS 0009 | Antenna                       | ARA 2                | MEB              |
| ETS 0010 | Antenna                       | Loop antenna         | MEB              |
| ETS 0011 | Antenna                       | van Veen/ Frame      | Rohde & Schwarz  |
| ETS 0012 | Antenna                       | HK 116               | Rohde & Schwarz  |
| ETS 0013 | Antenna                       | HL 223               | Rohde & Schwarz  |
| ETS 0014 | Antenna                       | HL 025               | Rohde & Schwarz  |
| ETS 0015 | Antenna                       | HL 025               | Rohde & Schwarz  |
| ETS 0016 | Precision antenna kit         | VHAP                 | Schwarzbeck      |
| ETS 0017 | Precision antenna kit         | UHAP                 | Schwarzbeck      |
| ETS 0018 | Horn antenna                  | BBHA 9120 D          | Schwarzbeck      |
| ETS 0019 | Horn antenna                  | BBHA 9120 D          | Schwarzbeck      |
| ETS 0020 | Antenna                       | DP 21                | MEB              |
| ETS 0021 | Antenna                       | DP 3                 | MEB              |
| ETS 0022 | Antenna                       | SAS-200/ 521         | A.H. Systeme+D65 |
| ETS 0023 | Antenna                       | DP 1                 | MEB              |
| ETS 0024 | Antenna mast                  | AF 2                 | MEB              |
| ETS 0025 | Antenna mast                  | AF 2                 | MEB              |
| ETS 0026 | Tripod                        |                      | Heinrich Deisel  |
| ETS 0027 | Tripod                        |                      | Heinrich Deisel  |
| ETS 0028 | Tripod                        | STA 2                | C. Lorenz AG     |
| ETS 0029 | Tripod                        |                      | Berlebach        |
| ETS 0030 | Antenna                       | HK 116               | Rohde & Schwarz  |
| ETS 0031 | Turn table                    | DS 412               | Heinrich Deisel  |
| ETS 0032 | Controller                    | HD 050               | Heinrich Deisel  |
| ETS 0033 | Calibr.Set CDN                | 3xAdapter 50-150 Ohm | ETS              |
| ETS 0034 | RF generator/ Amplifier       | SMLR                 | Rohde & Schwarz  |
| ETS 0035 | RF generator/ Amplifier       | SMLM                 | Rohde & Schwarz  |

| No.      | Test equipment               | Type            | Manufacturer        |
|----------|------------------------------|-----------------|---------------------|
| ETS 0036 | Zirc. Antenna                | 3102            | EMCO                |
| ETS 0037 | Zirc. Antenna                | 3102L           | EMCO                |
| ETS 0038 | RF amplifier                 | 150L            | Amplifier Research  |
| ETS 0039 | Absorbing clamp              | MDS 21          | Rohde & Schwarz     |
| ETS 0040 | Artificial mains             | ESH3-Z5         | Rohde & Schwarz     |
| ETS 0041 | Artificial mains             | ESH3-Z4         | Rohde & Schwarz     |
| ETS 0042 | Artificial mains             | ESH3-Z6         | Rohde & Schwarz     |
| ETS 0043 | Directional coupler          | 1850            | KRYTAR              |
| ETS 0044 | Artificial mains             | NNB 111         | MEB                 |
| ETS 0045 | Stripe line                  | IEC 801-3       | ETS                 |
| ETS 0046 | Power supply                 | LTS 006         | RFT                 |
| ETS 0047 | Power supply                 | TG 20/ 1        | Statron             |
| ETS 0048 | Power supply                 | TG 20/ 1        | Statron             |
| ETS 0049 | Power supply                 | T 102           | TPW                 |
| ETS 0050 | Power supply                 | T 101b          | TPW                 |
| ETS 0051 | Oscilloscope                 | TDS 640A        | Tektronix           |
| ETS 0053 | ECAT Control center          | CE 40           | Keytek/ EMV         |
| ETS 0054 | EFT simulator                | E 412           | Keytek/ EMV         |
| ETS 0055 | Module network coupler       | E 4551          | Keytek/ EMV         |
| ETS 0056 | Blank plug-in                |                 | Keytek/ EMV         |
| ETS 0057 | Module SURGE with DC coupler | E 501           | Keytek/ EMV         |
| ETS 0058 | Capacitive coupling clamp    | E 502 B         | Keytek/ EMV         |
| ETS 0059 | Kikusui amplifier            | PCR 2000L       | Keytek/ EMV         |
| ETS 0060 | Xitron power analyzer        |                 | Keytek/ EMV         |
| ETS 0061 | Power/ Arb (Harm., Ramp)     |                 | Keytek/ EMV         |
| ETS 0062 | Reference impedance          |                 | Keytek/ EMV         |
| ETS 0063 | Blank plug-in                |                 | Keytek/ EMV         |
| ETS 0064 | CDN IEC 1000-4-6             |                 | Keytek/ EMV         |
| ETS 0065 | ESD-generator minizap        |                 | Keytek/ EMV         |
| ETS 0066 | EM Injection Clamp           |                 | FCC/ EMV            |
| ETS 0067 | Calibration Fixture          | IEC 801-2031 CF | FCC/ EMV            |
| ETS 0068 | CDN IEC 1000-4-6             | CDN             | FCC/ EMV            |
| ETS 0069 | EM Radiation Monitor         | EMR-20          | Wandel & Goltermann |
| ETS 0070 | PC Transfer set EMR-20       | EMR-20          | Wandel & Goltermann |
| ETS 0071 | Video camera system          | KMB012          | Kocom               |
| ETS 0072 | Interphone system            | JS-1400         | Jiuh Sheng          |
| ETS 0073 | Audio noise meter            | GSM 2           | MKD/ RFT            |
| ETS 0074 | RF millivoltmeter            | QRV 2           | MKD/ RFT            |

| No.      | Test equipment                        | Type           | Manufacturer              |
|----------|---------------------------------------|----------------|---------------------------|
| ETS 0075 | NF generator                          | GF 22          | Präcitronic               |
| ETS 0076 | Feeding bridge A                      | SBA 1000       | ESP                       |
| ETS 0078 | LCR meter                             | SR 720         | SRS                       |
| ETS 0079 | Functional generator                  | MX-2020        | Maxcom                    |
| ETS 0080 | EMI Software                          | ES-K1          | Rohde & Schwarz           |
| ETS 0081 | EMI Software                          | ES-K10         | Rohde & Schwarz           |
| ETS 0082 | PC system                             | Novell         | Esotronic                 |
| ETS 0083 | Apple computer system                 | Performa 630   | Macintosh                 |
| ETS 0084 | Process controller                    | PSA 15         | Rohde & Schwarz           |
| ETS 0085 | Shielded room                         | SR 1           | Frankonia                 |
| ETS 0086 | Anechoic chamber                      | AC 1           | Frankonia                 |
| ETS 0087 | Climatic cell                         | HC 4033        | Heraeus                   |
| ETS 0088 | Color TV pattern generator            | PM 5518-TX VPS | Philips                   |
| ETS 0089 | Radio communication tester            | CMS 54         | Rohde & Schwarz           |
| ETS 0090 | DECT type approval CTR06              | TS 8930        | Rohde & Schwarz           |
| ETS 0091 | RF signal generator                   | SME 03         | Rohde & Schwarz           |
| ETS 0092 | Power amplifier                       | 150W1000       | AR Amplifier Research     |
| ETS 0093 | Attenuator                            | 57-20-33       | Weinschel                 |
| ETS 0094 | Power sensor                          | NRV-Z55        | Rohde & Schwarz           |
| ETS 0095 | DECT system controller                | PSMD           | Rohde & Schwarz           |
| ETS 0096 | DECT Signaling unit                   | PSMD-B11       | Rohde & Schwarz           |
| ETS 0097 | Rack, 19", 36 HU                      | TS 89RA        | Rohde & Schwarz           |
| ETS 0098 | System engineering and software       | CS 893BE       | Rohde & Schwarz           |
| ETS 0099 | Extension unit for basic version      | TS 8930B       | Rohde & Schwarz           |
| ETS 0100 | RF signal generator                   | SME-06         | Rohde & Schwarz           |
| ETS 0101 | Power amplifier                       | 50W1000B       | AR Amplifier Research     |
| ETS 0102 | CDN                                   | M3-801/6       | MEB                       |
| ETS 0103 | Magnetic field test set               | MF1000         | EMC Partner               |
| ETS 0105 | High power synthesizer/ sweeper       | SMP 22 / 02    | Rohde & Schwarz           |
| ETS 0106 | Antenna                               | VAMP 9443      | Schwarzbeck Meßelektronik |
| ETS 0108 | DECT protocol tester TBR 22           | TS 1220        | Rohde & Schwarz           |
| ETS 0109 | Process controller                    | PSM 2          | Rohde & Schwarz           |
| ETS 0110 | Real time signaling unit              | PSMD-B2        | Rohde & Schwarz           |
| ETS 0111 | PCM Real-time audio interface for PSM | PSMD-B3        | Rohde & Schwarz           |
| ETS 0112 | Synthesizer Module                    | PSMD-B4        | Rohde & Schwarz           |
| ETS 0113 | Keyboard                              | PSA-Z2         | Rohde & Schwarz           |
| ETS 0114 | RF step attenuator                    | RSG            | Rohde & Schwarz           |
| ETS 0115 | Glide path                            |                | Rohde & Schwarz           |

| No.      | Test equipment                       | Type          | Manufacturer    |
|----------|--------------------------------------|---------------|-----------------|
| ETS 0117 | Insertion unit                       | URV-Z2        | Rohde & Schwarz |
| ETS 0118 | Mixer                                | MFC 1000      | Avcom           |
| ETS 0119 | Mixer                                | MFC 2000      | Avcom           |
| ETS 0120 | RF step attenuator                   | TRI-50-20     | INCO            |
| ETS 0121 | Oscilloscope                         | EO 147A       | Serute          |
| ETS 0122 | Oscilloscope                         | 5201          | Dagatron        |
| ETS 0123 | RF step attenuator                   | RBU           | Rohde & Schwarz |
| ETS 0124 | Tripod                               | STA 2         | Rohde & Schwarz |
| ETS 0125 | Small components                     |               |                 |
| ETS 0126 | Uninterruptible power supply         | UPS - 1500    | Sendon          |
| ETS 0127 | Uninterruptible power supply         | UPS - 1000 LC | Sendon          |
| ETS 0128 | Uninterruptible power supply         | UPS - 1000    | Sendon          |
| ETS 0129 | Uninterruptible power supply         | UPS - 500     | Sendon          |
| ETS 0130 | Uninterruptible power supply         | Power saver   | Sendon          |
| ETS 0131 | Telephone connection box             |               | Systel          |
| ETS 0132 | Frequency doubler                    | TR-0616       | EMG             |
| ETS 0133 | Probe body                           | P6015         | Tektronix       |
| ETS 0135 | Measuring switching point            | AK 11         | RFT             |
| ETS 0136 | Attenuator                           | 33-6-34       | Weinschel       |
| ETS 0137 | Multimeter                           | YX-360TRA     | Mastech         |
| ETS 0138 | Multimeter                           | DT-9410       | Diditec         |
| ETS 0139 | Multimeter                           | ST-9202       | Standard        |
| ETS 0140 | High voltage generator               | IP 6Wa        | TPW             |
| ETS 0141 | Sliding bridge                       | J 573         | RFT             |
| ETS 0142 | Impedance converter                  | TK 11         | RFT             |
| ETS 0143 | Impedance converter                  | TK 12         | RFT             |
| ETS 0146 | Active RF probe                      | ESH2-Z2       | Rohde & Schwarz |
| ETS 0147 | Probe                                | TK 103        | MEB             |
| ETS 0149 | Power divider                        | ZAPD-21       | MCL             |
| ETS 0150 | Switcher                             | HR07-720      | Wisi            |
| ETS 0151 | Interference pulse generator         | NSG 500C      | Schaffner       |
| ETS 0155 | Signal generator                     | SMG           | Rohde & Schwarz |
| ETS 0157 | TV and Sat-Signalgenerator           | VTG 700       | Grundig         |
| ETS 0158 | TV and Sat Signalgenerator           | VTG 700       | Grundig         |
| ETS 0156 | Adjacent channel power meter         | NKS           | Rohde & Schwarz |
| ETS 0159 | Programmable power supply            | TOE 8815      | Toellner        |
| ETS 0160 | Protective wire and isolation tester | PI 6001 D     | SPS electronic  |
| ETS 0161 | Harmonic / Flicker Analyser          | HFA 3000      | Schlöder        |

| No.      | Test equipment                         | Type           | Manufacturer    |
|----------|--|----------------|-----------------|
| ETS 0162 | Acoustic chamber                       | 403-A          | IAC             |
| ETS 0163 | Test head                              | BK 4602        | Brüel & Kjær    |
| ETS 0164 | Simulator ear                          | BK 4185        | Brüel & Kjær    |
| ETS 0165 | Simulator mouth                        | BK 4227        | Brüel & Kjær    |
| ETS 0166 | Acoustic calibrator                    | BK 4231        | Brüel & Kjær    |
| ETS 0167 | Communication Analysis System          | CAS TE I       | HEAD acoustics  |
| ETS 0168 | Acoustical test for DECT               | CTR 10         | HEAD acoustics  |
| ETS 0169 | Measurement - Front-end (analogue)     | MFE III        | HEAD acoustics  |
| ETS 0170 | Measurement - Front-end (digital)      | MFE IV         | HEAD acoustics  |
| ETS 0171 | Electronic test cradle                 | TEH            | HEAD acoustics  |
| ETS 0172 | Noise generator                        | HNG III.1      | HEAD acoustics  |
| ETS 0173 | Speaker                                | Canton S Pluss | HEAD acoustics  |
| ETS 0174 | Measurement - Front-end line interface | MFE V          | HEAD acoustics  |
| ETS 0175 | Software line interface (analogue)     | COPTZV5        | HEAD acoustics  |
| ETS 0176 | Acoustic volt meter                    | COP 4          | HEAD acoustics  |
| ETS 0177 | Feeding bridge B                       | SBB 1000       | ESP             |
| ETS 0178 | Open area test side                    | 10m            | ETS             |
| ETS 0180 | Artificial mains                       | NNB01/RFZ      | RFZ             |
| ETS 0181 | Test pin for protective wire           | PE 156-i       | SPS electronic  |
| ETS 0182 | Power supply                           | MX-9300        | Maxcom          |
| ETS 0183 | Frequency counter                      | MX-9300        | Maxcom          |
| ETS 0184 | Function generator                     | MX-9300        | Maxcom          |
| ETS 0185 | Digital multimeter                     | MX-9300        | Maxcom          |
| ETS 0186 | Power supply                           | DF 1730        | WJG             |
| ETS 0187 | Power supply                           |                | TPW/RFT         |
| ETS 0188 | High voltage generator                 |                |                 |
| ETS 0189 | Spectrum analyzer                      | FSEB           | Rohde & Schwarz |
| ETS 0190 | Function generator                     | MX 2020        | Maxcom          |
| ETS 0191 | Sweep function generator               | 7202           | Dagatron        |
| ETS 0192 | Audio generator                        | 7101           | Dagatron        |
| ETS 0193 | Vibration table                        | N1-201-M       | Sandex          |
| ETS 0194 | Digital multimeter                     | PMM 208        | Dagatron        |
| ETS 0195 | Thermo hygro recorder                  |                | Amarell         |
| ETS 0196 | Digital thermometer                    | AK-688         | KD              |
| ETS 0197 | Digital thermometer                    |                | Prima           |
| ETS 0198 | Digital thermometer                    | ad 170th       | ama-digit       |
| ETS 0199 | Digital thermometer                    | ad 31th        | ama-digit       |

| No.      | Test equipment                            | Type       | Manufacturer       |
|----------|---|------------|--------------------|
| ETS 0200 | Digital thermometer / hygrometer          | ad 90h     | ama-digit          |
| ETS 0201 | Digital thermometer / hygrometer          | 37950-10   | Cole Parmer        |
| ETS 0202 | Digital thermometer                       | ad 15th    | ama-digit          |
| ETS 0204 | Digital thermometer                       | ad 20th    | ama-digit          |
| ETS 0205 | High voltage test generator               | HA 3300 D  | SPS electronic     |
| ETS 0206 | High voltage test accessories             | HVGZ 312   | SPS electronic     |
| ETS 0207 | Socket outlet torque balance              | F 37.13    | PTL                |
| ETS 0208 | Unjointed Finger probe                    | P 10.05    | PTL                |
| ETS 0209 | Flexible Finger probe                     | P 10.01    | PTL                |
| ETS 0210 | Spring operated impact hammer             | P 22.50    | PTL                |
| ETS 0211 | Metallic ball                             | F 53.32    | PTL                |
| ETS 0212 | Hazardous live probe                      | P 10.06    | PTL                |
| ETS 0213 | Hazardous live probe                      | P 10.11    | PTL                |
| ETS 0214 | Ball pressure test apparatus              | T 10.02    | PTL                |
| ETS 0215 | Glow Wire tester                          | T 03.14    | PTL                |
| ETS 0216 | Force indicator 50N                       | P 10.31    | PTL                |
| ETS 0218 | RF probe                                  | URV5-Z7    | Rohde & Schwarz    |
| ETS 0219 | Power sensor                              | NRV-Z2     | Rohde & Schwarz    |
| ETS 0221 | ISDN-S0-Analyzer                          | K1403      | Siemens            |
| ETS 0222 | ISDN Protocol Analyzer                    | TE965      | Tekelec Teleco.    |
| ETS 0223 | GSM/ PCN/ PCS-Simul.                      | TS8915B    | Rohde & Schwarz    |
| ETS0224A | Millivolt meter                           | URV5       | Rohde & Schwarz    |
| ETS0224B | Diode Power Sensor                        | NRV-Z1     | Rohde & Schwarz    |
| ETS0224C | Programmable high resolution time counter | PM6654G    | Philips            |
| ETS0224D | RF Stepp Attenuator                       | RSP        | Rohde & Schwarz    |
| ETS 0225 | SIM Simulator                             |            | Orga               |
| ETS 0226 | SIM Editor                                |            | Orga               |
| ETS 0227 | Vibration table                           | TIRA vib   | GenRad             |
| ETS 0228 | Climatic chamber                          | VT 4010    | Vötsch             |
| ETS 0229 | Radio commun. tester                      | CMT 54     | Rohde & Schwarz    |
| ETS 0230 | Radio commun. tester                      | CMD 65     | Rohde & Schwarz    |
| ETS 0232 | Radiation test source                     | VSQ 1      | MEB                |
| ETS 0233 | Direction coupler                         | RK 100     | MEB                |
| ETS 0234 | Power meter                               | NRVD       | Rohde & Schwarz    |
| ETS 0235 | RF network-analyzer                       | 8752 C     | Hewlett Packard    |
| ETS 0236 | RF amplifier                              | 100A100    | Amplifier Research |
| ETS 0237 | RF amplifier                              | 100W1000M1 | Amplifier Research |
| ETS 0238 | Field strength meter                      | FM 2000    | Amplifier Research |

| No.      | Test equipment            | Type        | Manufacturer       |
|----------|---------------------------|-------------|--------------------|
| ETS 0239 | Isotr. field probe 40 GHz | FP 2080 Kit | Amplifier Research |
| ETS 0240 | Isotr. field probe 1 GHz  | FP 2000 Kit | Amplifier Research |
| ETS 0241 | Pulse Generator           | 4050        | PicoSecond PL      |
| ETS 0242 | Harmonics analyzer        | F 41B       | Fluke              |
| ETS 0243 | AC-clamp 1000 A           | 80i 1000s   | Fluke              |
| ETS 0244 | Burst generator           | EFT 200     | EM-Test            |
| ETS 0245 | Load dump generator       | LD 200      | EM-Test            |
| ETS 0246 | Voltage drop simulator    | VDS 200     | EM-Test            |
| ETS 0247 | Microsecond generator     | MPG 200     | EM-Test            |
| ETS 0248 | Switch unit               | AN 200      | EM-Test            |
| ETS 0249 | Coupling network          | CNA 200     | EM-Test            |
| ETS 0250 | Coupling clamp            | ACC         | EM-Test            |
| ETS 0251 | Climatic chamber          | VT 4004     | Vötsch             |
| ETS 0252 | System controller         | PSM 12      | Rohde & Schwarz    |
| ETS 0253 | Spectrum analyzer         | FSIQ        | Rohde & Schwarz    |
| ETS 0254 | RF generator              | SMIQ 03     | Rohde & Schwarz    |
| ETS 0255 | RF generator              | SMIQ 03     | Rohde & Schwarz    |
| ETS 0256 | RF generator              | SMP 03      | Rohde & Schwarz    |
| ETS 0257 | Step attenuator           | RSP         | Rohde & Schwarz    |
| ETS 0258 | Rubidium standard         | RSTU        | DATUM GmbH         |
| ETS 0259 | Power meter               | NRVD        | Rohde & Schwarz    |
| ETS 0260 | Power sensor              | NRVD-Z1     | Rohde & Schwarz    |
| ETS 0261 | Power sensor              | NRVD-Z1     | Rohde & Schwarz    |
| ETS 0262 | Switching unit            | SSCU        | Rohde & Schwarz    |
| ETS 0263 | Signaling unit            | PTW60       | Rohde & Schwarz    |
| ETS 0264 | Spectrum analyzer         | F 1048      | HAMEG              |
| ETS 0265 | Loop antenna              | HFRA 9150   | Schwarzbeck        |
| ETS 0266 | Measurement adapter 1:100 | 50 Ohm      |                    |
| ETS 0267 | RF signal generator       | SMT 03      | Rohde & Schwarz    |
| ETS 0268 | RF signal generator       | SMP 02      | Rohde & Schwarz    |
| ETS 0269 | RF bridge 50 Ohm          | 86205 A     | Aglient            |
| ETS 0270 | RF signal generator       | SMP 04      | Rohde & Schwarz    |
| ETS 0271 | Spectrum analyser         | FSEK30      | Rohde & Schwarz    |
| ETS 0272 | RF signal generator       | SME 03      | Rohde & Schwarz    |
| ETS 0273 | RF signal generator       | SME 03      | Rohde & Schwarz    |
| ETS 0274 | RF signal generator       | SMY 01      | Rohde & Schwarz    |
| ETS 0275 | Power sensor              | NRV-Z51     | Rohde & Schwarz    |
| ETS 0276 | Audio analyzer            | UPL         | Rohde & Schwarz    |



| No.      | Test equipment        | Type      | Manufacturer       |
|----------|-----------------------|-----------|--------------------|
| ETS 0277 | Power sensor          | NRV-Z1    | Rohde & Schwarz    |
| ETS 0278 | Power sensor          | NRV-Z31   | Rohde & Schwarz    |
| ETS 0279 | Step attenuator       | RSP       | Rohde & Schwarz    |
| ETS 0280 | Power meter           | NRVD      | Rohde & Schwarz    |
| ETS 0281 | Spectrum analyzer     | FSM       | Rohde & Schwarz    |
| ETS 0282 | RF bridge 75 Ohm      | 86207 A   | Hewlett Packard    |
| ETS 0283 | RF bridge 50 Ohm      | 86205 A   | Hewlett Packard    |
| ETS 0284 | Field probe           | 11940 A   | Hewlett Packard    |
| ETS 0285 | Field probe           | 11941 A   | Hewlett Packard    |
| ETS 0286 | Limiter               | 11867 A   | Hewlett Packard    |
| ETS 0287 | Test receiver         | ESHS 10   | Rohde & Schwarz    |
| ETS 0288 | Artificial mains      | ESH2-Z5   | Rohde & Schwarz    |
| ETS 0289 | Audio generator       | TAG 101   | Troneer            |
| ETS 0290 | Audio generator       | TAG 101   | Troneer            |
| ETS 0291 | Loop antenna          | HFH2-Z2   | Rohde & Schwarz    |
| ETS 0292 | RF generator          | SMHU      | Rohde & Schwarz    |
| ETS 0293 | Artificial mains      | NNBM 8125 | Schwarzbeck        |
| ETS 0294 | Biconical antenna     | HK 116    | Rohde & Schwarz    |
| ETS 0295 | LPD antenna           | HL 223    | Rohde & Schwarz    |
| ETS 0297 | Power pulse generator | IGUF 2910 | Schwarzbeck        |
| ETS 0298 | ICO tester            | TS 1232   | Rohde & Schwarz    |
| ETS 0299 | DECT protocol tester  | TS 1220   | Rohde & Schwarz    |
| ETS 0300 | RF amplifier          | 75 A 250  | Amplifier Research |
| ETS 0301 | Relay switch unit     | RSU       | Rohde & Schwarz    |
| ETS 0302 | Data line CDN         | CM-I/O CD | Keytek             |
| ETS 0303 | Telecom line CDN      | CM-TEL CD | Keytek             |
| ETS 0304 | Test receiver         | ESHS 10   | Rohde & Schwarz    |
| ETS 0305 | Test receiver         | ESVS 10   | Rohde & Schwarz    |
| ETS 0306 | Function generator    | HP 33120A | Hewlett Packard    |
| ETS 0307 | Commu. Sign. Analyzer | CSA 803 A | Tektronix          |
| ETS 0308 | Spectrum analyzer     | R 3361A   | Advantest          |
| ETS 0309 | Anechoic chamber      | AC 2      | Frankonia          |
| ETS 0310 | Anechoic chamber      | AC 3      | Frankonia          |
| ETS 0311 | Anechoic chamber      | AC 4      | Frankonia          |
| ETS 0312 | Climatic chamber      | VC 0033   | Vötsch             |
| ETS 0313 | Power sensor          | NRV-Z51   | Rohde & Schwarz    |
| ETS 0314 | LPD antenna           | HL 223    | Rohde & Schwarz    |
| ETS 0315 | Biconical antenna     | HK 116    | Rohde & Schwarz    |

| No.      | Test equipment               | Type              | Manufacturer             |
|----------|------------------------------|-------------------|--------------------------|
| ETS 0316 | Switcher                     | Hr 07-720         | WISI                     |
| ETS 0318 | Dial pulse/ DTMF tester      | 210               | HE                       |
| ETS 0319 | Opto link                    | GPIB 140          | NI                       |
| ETS 0320 | Opto link                    | GPIB 140          | NI                       |
| ETS 0322 | Insertion unit               | URV5-Z4           | Rohde & Schwarz          |
| ETS 0323 | DECT portable part           | Gigaset 1000      | SIEMENS                  |
| ETS 0324 | DECT fix part                | Gigaset 1000      | SIEMENS                  |
| ETS 0325 | DECT portable part           |                   | Philipps                 |
| ETS 0326 | DECT fix part                |                   | Philipps                 |
| ETS 0327 | Blue Unit                    | V 2.0             | Nokia                    |
| ETS 0328 | ELF Field Strenght System    | HI-3604           | Holiday Industries, INC. |
| ETS 0329 | VDT/VLF Radiation System     | HI-3603           | Holiday Industries, INC. |
| ETS 0330 | Fiber Optic Remote Control   | HI.3616           | Holiday Industries, INC. |
| ETS 0331 | TS 1220                      |                   |                          |
| ETS 0332 | PSM                          |                   |                          |
| ETS 0333 | turn table                   | DE 350            | Heinrich Deisel          |
| ETS 0334 | Controllor                   | HD 100            | Heinrich Deisel          |
| ETS 0335 | BT development kit           | CASIRA            | CSR                      |
| ETS 0336 | LPD Antenna                  | HL 223            | Rohde & Schwarz          |
| ETS 0337 | Professional Power Amplifier | SE-1200           | Wharfedale Pro           |
| ETS 0338 | Coupling network             | KN002             | ETS                      |
| ETS 0339 | Isolating transformer        | KN003             | ETS                      |
| ETS 0340 | Thermometer                  |                   | Proficell                |
| ETS 0341 | Thermometer                  |                   | Proficell                |
| ETS 0342 | Thermometer                  |                   | Proficell                |
| ETS 0343 | Thermometer                  |                   | Proficell                |
| ETS 0344 | Thermometer                  |                   | Proficell                |
| ETS 0345 | Thermometer                  |                   | Proficell                |
| ETS 0346 | Thermometer                  |                   | Proficell                |
| ETS 0347 | Current Probe                | EZ-17             | Rohde & Schwarz          |
| ETS 0348 | RF millivoltmeter            | URV 55            | Rohde & Schwarz          |
| ETS 0349 | Insertion unit               | URV5-Z4           | Rohde & Schwarz          |
| ETS 0350 | Horn Antenna                 | BBHA 9120-C       | Schwarzbeck              |
| ETS 0351 | RF amplifier                 | DWT-1857          | Microwave                |
| ETS 0354 | RF amplifier                 | DBS-0408N423      | Microwave                |
| ETS 0355 | high pass                    | H03G12G3          | Microwave                |
| ETS 0356 | high pass                    | H03G12G3          | Microwave                |
| ETS 0357 | high pass                    | H08G18G3          | Microwave                |
| ETS 0358 | RF amplifier                 | AFD3-010040-15-ln | MITEQ                    |
| ETS 0359 | RF amplifier                 | M/N AM-1331       | MITEQ                    |
| ETS 0360 | RF amplifier                 | DBS-0408N423      | Microwave                |
| ETS 0361 | RF amplifier                 | DBS 1826N515      | Microwave                |

| No.      | Test equipment                  | Type              | Manufacturer    |
|----------|---------------------------------|-------------------|-----------------|
| ETS 0362 | high pass                       | H03G12G3          | Microwave       |
| ETS 0363 | high pass                       | H08G18G3          | Microwave       |
| ETS 0364 | high pass                       | H08G18G3          | Microwave       |
| ETS 0365 | Notch filter 2.4 GHz            | WRCT2.40/248      | Wain Wright     |
| ETS 0366 | high pass                       | H08G18G3          | Microwave       |
| ETS 0367 | high pass                       | H03G12G3          | Microwave       |
| ETS 0368 | Notch filter 0.5-1 GHz          | BN86883           | Schomandl       |
| ETS 0369 | Notch filter 210-500 MHz        | BN86882           | Schomandl       |
| ETS 0370 | Notch filter 15-90 MHz          | BN86880           | Schomandl       |
| ETS 0371 | Notch filter 85-250 MHz         | BN86881           | Schomandl       |
| ETS 0372 | Direction coupler               | RK 100            | MEB             |
| ETS 0373 | Direction coupler               | DC3001            | emv             |
| ETS 0374 | Power Supply                    | NGSM32            | Rohde & Schwarz |
| ETS 0375 | Vector Signal Generator         | SMIQ03B           | Rohde & Schwarz |
| ETS 0376 | Signal Generator                | SMP22             | Rohde & Schwarz |
| ETS 0377 | Advanced Signal Condi. Unit     | ASCU850           | Rohde & Schwarz |
| ETS 0378 | Advanced Signal Condi. Unit     | ASCU190           | Rohde & Schwarz |
| ETS 0379 | Advanced Signal Condi. Unit     | ASCU180           | Rohde & Schwarz |
| ETS 0380 | Advanced Signal Condi. Unit     | ASCU900           | Rohde & Schwarz |
| ETS 0381 | Ethernet HUB                    | CS-HUB            | Rohde & Schwarz |
| ETS 0382 | Vector Signal Generator         | SMIQ03B           | Rohde & Schwarz |
| ETS 0383 | Spectrum Analyzer               | FSU26             | Rohde & Schwarz |
| ETS 0384 | Main Frame Signal and Con. Unit | SSCU-GW           | Rohde & Schwarz |
| ETS 0385 | Universal Protocol Tester       | CRTU-RU           | Rohde & Schwarz |
| ETS 0386 | Power meter                     | NRVD              | Rohde & Schwarz |
| ETS 0387 | Power sensor                    | NRV-Z1            | Rohde & Schwarz |
| ETS 0388 | Power sensor                    | NRV-Z1            | Rohde & Schwarz |
| ETS 0389 | Fading Simulator                | ABFS              | Rohde & Schwarz |
| ETS 0390 | System PC PC3600                | TS-PC36           | Rohde & Schwarz |
| ETS 0391 | Rubidium Frequency Standard     | DATUM 8040        | DATUM GmbH      |
| ETS 0392 | RF Distribution                 | DATUM 6502        | DATUM GmbH      |
| ETS 0393 | Insertion unit                  | URV5-Z4           | Rohde & Schwarz |
| ETS 0394 | Advanced Signal Cond. Unit      | ASCUFDD-WCDMA     | Rohde & Schwarz |
| ETS 0395 | Universal Protocol Tester       | CRTU-RU           | Rohde & Schwarz |
| ETS 0396 | Universal Protocol Tester       | CRTU-RU           | Rohde & Schwarz |
| ETS 0397 | Universal Protocol Tester       | CRTU-RU           | Rohde & Schwarz |
| ETS 0398 | Fading Simulator                | ABFS              | Rohde & Schwarz |
| ETS 0399 | Universal Protocol Tester       | CRTU-PU           | Rohde & Schwarz |
| ETS 0400 | Universal Protocol Tester       | CRTU-W            | Rohde & Schwarz |
| ETS 0418 | High pass filter 4-8GHz         |                   | Microwave       |
| ETS 0419 | High pass filter 8-18 GHz       |                   | Microwave       |
| ETS 0420 | Amplifier 0.1-1 GHz             | M/N AM-1331       | MITEC           |
| ETS 0421 | Amplifier 1-4 GHz               | AFD3-010040-15-LN | MITEC           |
| ETS 0422 | Amplifier 4-8 GHz               | DBS-0408N423      | Narda           |
| ETS 0423 | Amplifier 8-18 GHz              | DWT-18057         | Narda           |
| ETS 0424 | Amplifier 18-26.5 GHz           | DBS-1826N515      | Narda           |

| No.      | Test equipment                   | Type             | Manufacturer                |
|----------|----------------------------------|------------------|-----------------------------|
| ETS 0425 | T-network                        | ESH 3-Z4         | R&S                         |
| ETS 0426 | CDN                              | T4 HF            | MEB                         |
| ETS 0427 | Power sensor                     | NRV-Z6           | Rohde & Schwarz             |
| ETS 0428 | 4-WIRE ISN with B1               | ENY41            | Rohde & Schwarz             |
| ETS 0429 | Current probe test jig           | SW14 7LY         | Chase                       |
| ETS 0430 | RF signal generator              | SML02            | R&S                         |
| ETS 0431 | AC mains adapter                 | BS5733           | Travel Emporium             |
| ETS 0432 | RF amplifier matrix              | RSU-ETS-BT       | ETS                         |
| ETS 0433 | RF amplifier matrix              | RSU-ETS-CTR6     | ETS                         |
| ETS 0434 | Reserved Tre                     | RSU-ETS-GSM      |                             |
| ETS 0435 | HP-Filter                        | H1G04G01         | Microwave                   |
| ETS 0436 | HP-Filter                        | H1G04G01         | Microwave                   |
| ETS 0437 | HP-Filter                        | H0G408G1         | Microwave                   |
| ETS 0438 | HP-Filter                        | H0G408G1         | Microwave                   |
| ETS 0439 | Amplifier                        | DBS-1826N515     | Narda-DBS-Microwave         |
| ETS 0440 | Amplifier                        | AM-1331          | MITEQ                       |
| ETS 0441 | Bluetooth Protocol Tester        | PTW 60           | Rohde & Schwarz             |
| ETS 0442 | Nokia Tester for Bluetooth 1.1   | DTL - 1          | Nokia                       |
| ETS 0443 | IBM BT PC Card                   | BTPCN101         | IBM / Motorola              |
| ETS 0444 | Sony BT DUN Modem                | BTA- NW 1        | Sony                        |
| ETS 0445 | RF attenuator 6dB                | 50FH-006-300     | JFK                         |
| ETS 0446 | RF attenuator 30dB               | 50FH-030-300     | JFK                         |
| ETS 0447 | Motor vehicle artificial network | LN-KFZ/200       | R. Heine Hochfrequenztechn. |
| ETS 0448 | RF power amplifier               | AR 60S1G3        | AR Amplifier Resarch        |
| ETS 0449 | Stäubli robot                    | RX90B L          | Stäubli                     |
| ETS 0450 | Stäubli robot controller         | CS/MBs&p         | Stäubli                     |
| ETS 0451 | DASY 4 measurement server        |                  | Schmidt & Partner           |
| ETS 0452 | Control pendant                  |                  | Stäubli                     |
| ETS 0453 | Compaq computer                  | Pentium IV 2 GHz | Schmidt & Partner           |
| ETS 0454 | Dabu acquisition electronics     | DAE3V1           | Schmidt & Partner           |
| ETS 0455 | Dummy probe                      |                  | Schmidt & Partner           |
| ETS 0456 | Dosimetric E-field probe         | ET3DV6           | Schmidt & Partner           |
| ETS 0457 | Dosimetric E-field probe         | ET3DV6           | Schmidt & Partner           |
| ETS 0458 | Dosimetric H-field probe         | H3DV6            | Schmidt & Partner           |
| ETS 0459 | System validation kit            | D900V2           | Schmidt & Partner           |
| ETS 0460 | System validation kit            | D1800V2          | Schmidt & Partner           |
| ETS 0461 | System validation kit            | D1900V2          | Schmidt & Partner           |
| ETS 0462 | System validation kit            | D2450V2          | Schmidt & Partner           |
| ETS 0463 | Probe alignment unit             | LBV2             | Schmidt & Partner           |
| ETS 0464 | SAM twin phantom                 | V4.0             |                             |
| ETS 0465 | Mounting device                  | V 3.1            |                             |
| ETS 0466 | Directional coupler              | HP 87300B        |                             |
| ETS 0468 | Isotropic E-Field Probe          | ER3DV6           | Schmid&Partner              |
| ETS 0469 | Dielectric probe kit             | 85070D           | Agilent                     |
| ETS 0470 | Amplifier                        | AM-1300-1103     | MITEQ                       |
| ETS 0472 | Antenna                          | BTA-H            | Frankonia                   |

| No.      | Test equipment                          | Type                    | Manufacturer          |
|----------|---|-------------------------|-----------------------|
| ETS 0473 | GSM / UMTS system simulator             | TS 8950                 | Rohde & Schwarz       |
| ETS 0474 | EMI test receiver                       | ESCS30                  | Rohde & Schwarz       |
| ETS 0475 | Amplifier                               | AFS4-00101800-U         | MITEQ                 |
| ETS 0476 | Test receiver                           | ESCS 30                 | Rohde & Schwarz       |
| ETS 0477 | GPS system (active GPS antenna)         | 4490                    | HOPF                  |
| ETS 0478 | Crystal filter                          | MQF 127.50-2400/F       | Vectron International |
| ETS 0480 | Validation dipole                       | DB 3                    | EMCO                  |
| ETS 0481 | 40GHz standard gain horn with amplifier | 22240-25<br>CBL26402075 | Flann Microwave       |
| ETS 0482 | 40GHz high gain antenna                 | AT4560                  | Amplifier research    |
| ETS 0483 | Amplifier                               | AFD3010040-15-LN        | MITEQ                 |
| ETS 0485 | Radio Communication Tester              | CMU 200                 | Rohde & Schwarz       |
| ETS 0490 | Rubidium Frequency Standard             | 8040                    | DATUM                 |
| ETS 0491 | RF Distribution                         | 6502                    | DATUM                 |
| ETS 0492 | Indusrtial Cotroller                    | PSM12                   | R & S                 |
| ETS 0493 | Protokoll Tester                        | PTW60                   | R & S                 |
| ETS 0494 | Switching unit                          | SSCU                    | R & S                 |
| ETS 0495 | RF Step Attenuator                      | RSP                     | R & S                 |
| ETS 0496 | Spectrum Analyzer                       | FSP                     | R & S                 |
| ETS 0497 | Power Meter                             | NRVD                    | R & S                 |
| ETS 0498 | Diode Power Sensor                      | NRV-Z1                  | R & S                 |
| ETS 0499 | Diode Power Sensor                      | NRV-Z1                  | R & S                 |
| ETS 0500 | Signal Generator                        | SMIQ03                  | R & S                 |
| ETS 0501 | Signal Generator                        | SMIQ03                  | R & S                 |
| ETS 0502 | Power Splitter                          | DS-808-4                | Macom                 |

## **2.4 Examinations and Test Procedures**

The test procedures are performed following the requirements of FCC Part 15 and test standard Revision Draft 1.1 of ANSI C63.17-1998 [American National Standard for Methods of Measurement of the Electromagnetic and Operational Compatibility of Unlicensed Personal Communications Services (UPCS) Devices].

### **2.4.1 Coordination with fixed microwave service, FCC 15.307 (b)**

UTAM, Inc., is designated to coordinate and manage the transition of the 1910 – 1930 MHz band from Private Operational-Fixed Microwave Service (OFS) operating under Part 94 of this Chapter to unlicensed PCS operations.

Therefore each applicant for certification operating under the provisions of this Subpart must be accompanied by an affidavit from UTAM, Inc. certifying that the applicant is a participating member of UTAM, Inc.

### **2.4.2 Reference to Subpart B, FCC 15.309 (b)**

The requirements of Subpart D apply only to the radio transmitter contained in the PCS device. Other aspects of the operation of a PCS device may be subject to requirements contained elsewhere in this Chapter. In particular, a PCS device that includes digital circuitry not direct associated with the radio transmitter also is subject to the requirements for unintentional radiators in Subpart B,

Test procedure: FCC Part 15B

### **2.4.3 Labeling requirements, FCC 15.311, 15.19; DA05-1005**

This requirement is provisional suspended by FCC Public Notice DA 05-1005 dated April 04, 2005.

### **2.4.4 Conducted limits AC Power line, FCC 15.315, 15.207**

An unlicensed PCS device that is designated to be connected to the public utility (AC) power line must meet the limits specified in Section 15.207.

Test procedure: FCC Part 15.207

### **2.4.5 Antenna requirement, FCC 15.317, 15.203**

An unlicensed PCS device must meet the antenna requirement of Section 15.203

Test procedure: Visual inspection

#### **2.4.6 Modulation techniques, FCC 15.319 (b)**

All transmissions must use only digital modulation techniques.

Procedure: Consideration of declaration provided by applicant.

#### **2.4.7 Emission band width, FCC 15.323 (a)**

Operation will be contained within the 1920 – 1930 MHz band. The emission band width shall be less than 2.5 MHz, but in no event the emission band width shall be less than 50 kHz.

Test procedure: ANSI 63.17 Sub-clause 6.1.3

#### **2.4.8 Peak transmit power, FCC 15.319 (c), FCC 15.31(e)**

Peak transmit power shall not exceed 100 microwatts multiplied by the square root of the emission band width in hertz. Peak transmit power must be measured over any interval of continuous transmission using instrumentation calibrated in terms of an rms-equivalent voltage. The measurement results shall be properly adjusted for any instrument limitations, such as detector response times, limited resolution band width capability when compared to the emission band width, sensitivity, etc., so as to obtain a true peak measurement for the emission in question over the full band width of the channel.

The variation of the signal level of the fundamental emission shall be tested with the supply voltage varied between 85% and 115% of the nominal rated supply voltage. For battery-operated equipment the tests shall be performed using a new battery.

Test procedure: ANSI 63.17 Sub-clause 6.1.2

#### **2.4.9 Power spectral density, FCC 15.319 (d)**

Power spectral density shall not exceed 3 mW in any 3 kHz band width as measured with a spectrum analyzer having a resolution band width of 3 kHz.

Test procedure: ANSI 63.17 Sub-clause 6.1.5

#### **2.4.10 Directional gain of antenna, FCC 15.319 (e)**

The peak transmit power shall be reduced by the amount in decibels that the maximum directional gain of the antenna exceeds 3 dBi.

Procedure: Consideration of antenna gain value provided by manufacturer or additional radiated test of Peak transmit power.

#### **2.4.11 Automatic discontinuation of transmission, FCC 15.319 (f)**

The device shall automatically discontinue transmission in case of either absence of information to transmit or operational failure. These provisions are not intended to preclude transmission of control and signaling information or use of repetitive codes used by certain digital technologies to complete frame or burst intervals.

Procedure: Consideration of declaration provided by applicant.

#### **2.4.12 Radio frequency radiation exposure, FCC 15.319 (i)**

UPCS devices are subject to the radio frequency radiation exposure requirements specified in FCC parts 1.1307 (b), 2.1091 and 2.1093, as appropriate. All equipment shall be considered to operate in a “general population / uncontrolled environment. For portable devices tests according to IEEE 1528 are requested, if applicable.

Procedure: MPE or SAR evaluation depending on power value – distance to human body criteria.

#### **2.4.13 Monitoring threshold; Least interfered channel; FCC 15.323 (c)(2); (c)(5); (c)(9)**

The lower monitoring threshold for EUTs without LIC procedure (least interfered channel) must not be more than 30 dB above the thermal noise power for a band width equivalent to the emission band width of the device.

Test procedure: Revision Draft 1.1 ANSI 63.17 Sub-clause 7.3.1.1; 7.3.1.1.2; 7.3.1.1.3

Devices that have a power output lower than the maximum permitted under the rules can increase their monitoring detection threshold by one decibel for each one decibel that the transmitter power is below the maximum permitted.

Test procedure: Revision Draft ANSI 63.17 Sub-clause 4.4 or 4.7, if applicable

For EUTs which support least interfered channel procedure (LIC) there is no need to measure the lower threshold because the rule 15.323(c)(2) is automatically met by the LIC procedure. For EUTs with 40 and more logical channels the upper threshold is applicable.

#### **2.4.14 Monitoring of intended transmit window and maximum reaction time, FCC 15.323 (c)(1)**

Immediately prior to initiating transmission, devices must monitor the combined time and spectrum window in which they intend to transmit. For a period of at least 10 milliseconds for systems designed to use a 10 millisecond or shorter frame period or at least 20 milliseconds for systems designed to use a 20 millisecond frame period.

Test procedure: ANSI 63.17 Sub-clause 7.5



#### **2.4.15 Monitoring band width, Monitoring reaction time, FCC 15.323 (c)(7)**

The monitoring system band width must be equal to or greater than the emission band width of the intended transmission and have a maximum reaction time less than  $50 \times \text{SQRT}(1.25/\text{emission band width in MHz})$  microseconds for signals at the applicable threshold level but shall not be required to be less than 50 microsecond. If a signal is detected that is 6 dB or more above the applicable threshold level, the maximum reaction time shall be  $35 \times \text{SQRT}(1.25/\text{emission band width in MHz})$  microseconds but shall not be required to be less than 35 microseconds.

Test procedure: ANSI 63.17 Sub-clause 7.4 and 7.5

#### **2.4.16 Random waiting interval, FCC 15.323 (c)(6)**

If the selected combined time and spectrum windows are unavailable, the device may either monitor and select different windows or seek to use the same window after waiting an amount of time, randomly chosen from a uniform random distribution between 10 and 150 milliseconds, commencing when the channel becomes available.

Test procedure: ANSI 63.17 Sub-clause 8.1

#### **2.4.17 Duration of Transmission, FCC 15.323 (c)(3)**

If no signal above the threshold level is detected, transmission may commence and continue with the same emission band width in the monitored time and spectrum windows without further monitoring. However, occupation of the same combined time and spectrum window by a device or group of cooperating devices continuously over a period of time longer than 8 hours is not permitted without repeating the access criteria.

Procedure: Consideration of declaration provided by applicant or test according to ANSI 63.17 Sub-clause 8.2.2

#### **2.4.18 Connection acknowledgements, Unacknowledged transmissions FCC 15.323 (c)(4)**

Once access to specific combined time and spectrum windows is obtained an acknowledgement from a system participant must be received by the initiating transmitter within one second or transmission must cease. Periodic acknowledgements must be received at least every 30 seconds or transmission must cease. Channels used exclusively for control and signaling information may transmit continuously for 30 seconds without receiving an acknowledgement, at which time the access criteria must be repeated.

Test procedure: ANSI 63.17 Sub-clause 8.2.1

#### **2.4.19 Selected channel confirmation, segment occupancy, FCC 15.323 (c)(5)**

If a minimum of 40 duplex system access channels are defined, the system must have monitored all access channels defined for its system within the last 10 seconds and must verify, within the 20 milliseconds (40 milliseconds for devices designed to use a 20 milliseconds frame period) immediately preceding actual channel access that the detected power of the selected time and spectrum windows is no higher than the previously detected value.

The power measurement resolution for this comparison must be accurate within 6 dB.

No device or group of co-operating devices located within 1 meter of each other shall during any frame period occupy more than 6 MHz of aggregate band width, or alternatively, more than one third of the time and spectrum windows defined by the system.

Test procedure: ANSI 63.17 Sub-clause 7.3.1.2

#### **2.4.20 Monitoring antenna, FCC 15.323 (c)(8)**

The monitoring system shall use the same antenna used for transmission, or an antenna that yields equivalent reception at that location.

Procedure: Consideration of declaration provided by applicant or test according to ANSI 63.17 Sub-clause 4

#### **2.4.21 Duplex connections, FCC 15.323 (c)(10)**

An initiating device may attempt to establish a duplex connection by monitoring both its intended transmit and receive time spectrum windows. If both the intended transmit and receive time and spectrum window meet the access criteria, then the initiating device can initiate a transmission in the intended transmit time and spectrum window. If the power detected by the responding device can be decoded as a duplex connection signal from the initiating device, then the responding device may immediately begin transmitting on the receive time and spectrum window monitored by the initiating device.

Test procedure: Revision Draft ANSI 63.17 Sub-clause 8.2.1, if applicable

#### **2.4.22 Alternative monitoring interval for co-located devices, FCC 15.323 (c)(11)**

An initiating device that is prevented from monitoring during its intended transmit window due to monitoring system blocking from the transmissions of a co-located (within one meter) transmitter of the same system, may monitor the portions of the time and spectrum windows in which they intend to receive over a period of at least 10 milliseconds. The monitored time and spectrum window must total at least 50 percent of the 10 millisecond frame interval and the monitored spectrum must be within 1.25 MHz of the center frequency of channel(s) already occupied by that device or co-located co-operating device. If the access criteria is met for the intended receive time and spectrum window under the above conditions, then transmission in the intended transmit window by the initiating device may commence.

Test procedure: ANSI 63.17 Sub-clause 8.2.4, if applicable

#### **2.4.23 Fair access to spectrum related to (c)(10) and (c)(11), FCC 15.323 (c)(12)**

The provisions of (c)(10) or (c)(11) shall not be used to extend the range of spectrum occupied over space or time for the purpose of denying fair access to spectrum for other devices.

#### **2.4.24 Emissions inside and outside the sub-bands, FCC 15.323 (d)**

Emissions outside the sub-bands shall be attenuated below a reference power of 112 milliwatts as follows: 30 dB between the sub-band and 1.25 MHz above or below the sub-band; 50 dB between 1.25 and 2.5 MHz above or below the sub-band; and 60 dB at 2.5 MHz or greater above or below the sub-band.

Emissions inside the sub-band must comply with the following emission mask: In the bands between 1B and 2B ("B" is defined as the emission band width of the device in hertz) measured from the center of the emission band width the total power emitted by the device shall be at least 50 dB below the transmit power permitted for that radiator; in the bands between 3B and the sub-band edge the total power emitted by an intentional radiator in the measurement band width shall be at least 60 dB below the transmit power permitted for that radiator.

Compliance with the emission limits is based on the use of measurement instrumentation employing peak detector function with an instrument resolution band width approximately equal to 1.0 percent of the emission band width of the device under measurement.

Test procedure: ANSI 63.17 Sub-clause 6.1.6.1; 6.1.6.2

#### **2.4.25 Frame period, FCC 15.323 (e)**

The frame period (a set of consecutive time slots in which the position of each time slot can be identified by reference to a synchronizing source) of an intentional radiator operating in these subbands shall be 20 milliseconds/X where x is a positive whole number. Each device that implements time division for the purposes of maintaining a duplex connection on a given frequency carrier shall maintain a frame repetition rate with a frequency stability of at least 50 parts per millions (ppm). Each devices which further divides access in time in order to support multiple communication links on a given frequency carrier shall maintain a frame repetition rate with a frequency stability of at least 10 ppm. The jitter (time-related, abrupt, spurious variations in the duration of the frame interval) introduced at the two ends of such a communication link shall not exceed 25 microseconds for any two consecutive transmissions.

Transmissions shall be continuous in every time and spectrum window during the frame period defined for the device.

#### **2.4.26 Frequency stability, FCC 15.323 (f)**

The frequency stability of the carrier frequency of the intentional radiator shall be maintained within  $\pm 10$  ppm over 1 hour or the interval between channel access monitoring, whichever is shorter. The frequency stability shall be maintained over a temperature variation of  $-20^{\circ}$  to  $+50^{\circ}$  degrees C at normal supply voltage, and over a variation in the primary supply voltage of 85 percent to 115 percent of the rated supply voltage at a temperature of  $20^{\circ}$ C. For equipment that is capable only of operating from a battery, the frequency stability test shall be performed using a new battery without any further requirements to vary supply voltage.

### 3 RESULTS OF EXAMINATIONS AND TESTS (enclosure)

| TEST CASE  | FCC Rules                   | Required                            | Customer Declaration                | Test passed                         | Test failed              |
|--|-----------------------------|-------------------------------------|-------------------------------------|-------------------------------------|--------------------------|
| Coordination with fixed microwave service                        | FCC 15.307 (b)              | <input checked="" type="checkbox"/> | <input checked="" type="checkbox"/> | <input type="checkbox"/>            | <input type="checkbox"/> |
| Reference to Subpart B   | FCC 15.309 (b)              | <input type="checkbox"/>            | <input type="checkbox"/>            | <input type="checkbox"/>            | <input type="checkbox"/> |
| Labeling requirements  | FCC 15.311, 15.19(a)(3)     | <input type="checkbox"/>            | <input type="checkbox"/>            | <input type="checkbox"/>            | <input type="checkbox"/> |
| Conducted limits AC Power line                                   | FCC 15.315 , 15.207         | <input checked="" type="checkbox"/> | <input type="checkbox"/>            | <input checked="" type="checkbox"/> | <input type="checkbox"/> |
| Antenna requirement  | FCC 15.317, 15.203          | <input checked="" type="checkbox"/> | <input type="checkbox"/>            | <input checked="" type="checkbox"/> | <input type="checkbox"/> |
| Modulation techniques  | FCC 15.319 (b)              | <input checked="" type="checkbox"/> | <input checked="" type="checkbox"/> | <input type="checkbox"/>            | <input type="checkbox"/> |
| Emission band width  | FCC 15.323 (a)              | <input checked="" type="checkbox"/> | <input type="checkbox"/>            | <input checked="" type="checkbox"/> | <input type="checkbox"/> |
| Peak Transmit Power  | FCC 15.319 (c)              | <input checked="" type="checkbox"/> | <input type="checkbox"/>            | <input checked="" type="checkbox"/> | <input type="checkbox"/> |
| Power spectral density   | FCC 15.319 (d)              | <input checked="" type="checkbox"/> | <input type="checkbox"/>            | <input checked="" type="checkbox"/> | <input type="checkbox"/> |
| Directional gain of the antenna                                  | FCC 15.319 (e)              | <input checked="" type="checkbox"/> | <input checked="" type="checkbox"/> | <input type="checkbox"/>            | <input type="checkbox"/> |
| Automatic discontinuation of transmission                        | FCC 15.319 (f)              | <input checked="" type="checkbox"/> | <input checked="" type="checkbox"/> | <input type="checkbox"/>            | <input type="checkbox"/> |
| Radio frequency radiation exposure                               | FCC 15.319 (i)              | <input checked="" type="checkbox"/> | <input type="checkbox"/>            | <input checked="" type="checkbox"/> | <input type="checkbox"/> |
| Monitoring threshold   | FCC 15.323(c)(2);<br>(c)(9) | <input checked="" type="checkbox"/> | <input type="checkbox"/>            | <input checked="" type="checkbox"/> | <input type="checkbox"/> |
| Monitoring of intended transmit window and maximum reaction time | FCC 15.323(c)(1)            | <input checked="" type="checkbox"/> | <input type="checkbox"/>            | <input checked="" type="checkbox"/> | <input type="checkbox"/> |
| Monitoring band width  | FCC 15.323 (c)(7)           | <input checked="" type="checkbox"/> | <input type="checkbox"/>            | <input checked="" type="checkbox"/> | <input type="checkbox"/> |
| Random waiting interval,   | FCC 15.323 (c)(6)           | <input type="checkbox"/>            | <input type="checkbox"/>            | <input type="checkbox"/>            | <input type="checkbox"/> |
| Duration of transmission,  | FCC 15.323 (c)(3)           | <input checked="" type="checkbox"/> | <input type="checkbox"/>            | <input checked="" type="checkbox"/> | <input type="checkbox"/> |
| Connection acknowledgement,                                      | FCC 15.323 (c)(4)           | <input checked="" type="checkbox"/> | <input type="checkbox"/>            | <input checked="" type="checkbox"/> | <input type="checkbox"/> |
| Selected channel confirmation, power accuracy, segment occupancy | FCC 15.323 (c)(5)           | <input checked="" type="checkbox"/> | <input type="checkbox"/>            | <input checked="" type="checkbox"/> | <input type="checkbox"/> |
| Monitoring antenna,  | FCC 15.323 (c)(8)           | <input checked="" type="checkbox"/> | <input checked="" type="checkbox"/> | <input type="checkbox"/>            | <input type="checkbox"/> |
| Duplex connections   | FCC 15,323 (c)(10)          | <input checked="" type="checkbox"/> | <input type="checkbox"/>            | <input checked="" type="checkbox"/> | <input type="checkbox"/> |
| Alternative monitoring interval for co-located devices           | FCC 15.323 (c)(11)          | <input checked="" type="checkbox"/> | <input checked="" type="checkbox"/> | <input type="checkbox"/>            | <input type="checkbox"/> |
| Fair access to spectrum related to (c)(10) and (c)(11)           | FCC 15.323 (c)(12)          | <input checked="" type="checkbox"/> | <input checked="" type="checkbox"/> | <input type="checkbox"/>            | <input type="checkbox"/> |
| Emissions inside and outside the sub-band                        | FCC 15.323 (d)              | <input checked="" type="checkbox"/> | <input type="checkbox"/>            | <input checked="" type="checkbox"/> | <input type="checkbox"/> |
| Frame period   | FCC 323 (e)                 | <input checked="" type="checkbox"/> | <input type="checkbox"/>            | <input checked="" type="checkbox"/> | <input type="checkbox"/> |
| Frequency stability  | FCC 323 (f)                 | <input checked="" type="checkbox"/> | <input type="checkbox"/>            | <input checked="" type="checkbox"/> | <input type="checkbox"/> |

### 3.1 Coordination with fixed microwave service, FCC 15.307 (b)

|  |                                     |
|--|-------------------------------------|
| The affidavit from UTAM Inc. is attached in Appendix B   | <input checked="" type="checkbox"/> |
| The applicant will provide the affidavit from UTAM Inc. later in the course of certification by TCB or FCC | <input type="checkbox"/>            |

### 3.2 Reference to Subpart B, FCC 15.309 (b)

|   |                                     |
|---|-------------------------------------|
| This requirement is not applicable because the test sample do not include digital circuitry which is not direct associated with the radio transmitter | <input checked="" type="checkbox"/> |
| For test results according to FCC 15B see Appendix C  | <input type="checkbox"/>            |
| This requirement is covered by results of radiated emission test according to FCC 15.323(d)   | <input type="checkbox"/>            |

### 3.3 Labeling requirements, FCC 15.311; 15.19 (a)(3)

This requirement is provisional suspended by FCC Public Notice DA 05-1005 dated April 04, 2005.

|  |                                     |
|--|-------------------------------------|
| The applicant will provide labeling documentation later in the course of certification by TCB or FCC   | <input checked="" type="checkbox"/> |
| Labeling of the test sample confirms to the requirements of DA05-1005 for documentation see Appendix D | <input type="checkbox"/>            |

### 3.4 Conducted limits AC Power line, FCC 15.315 , 15.207

For an intentional radiator which is designed to be connected to the public utility (AC) power line, the radio frequency voltage that is conducted back onto the AC line on any frequency or frequencies within the band 150 kHz to 30 MHz shall not exceed the limits in the table below. Compliance with this provision shall be based on the measurement of the radio frequency voltage between each power line and ground at the power terminals.

This measurement was transact first with instrumentation using an average and peak detector and a 10 kHz band width. If the peak detector achieves a calculated level, the measurement is repeated by an instrumentation using a quasi-peak detector.

| Frequency | Level            |                  |
|-----------|------------------|------------------|
|           | quasi-peak       | average          |
| 150 kHz   | Lower limit line | Lower limit line |

#### Limits:

| Frequency of Emission (MHz) | Conducted Limit (dBuV) |          |
|-----------------------------|------------------------|----------|
|                             | Quasi Peak             | Average  |
| 0.15-0.5                    | 66 to 56               | 56 to 46 |
| 0.5-5                       | 56                     | 46       |
| 5-30                        | 60                     | 50       |

Test equipment used: ETS 0125; ETS 0288; ETS 0474

Comment: See attached diagrams in Appendix E.

### 3.5 Antenna requirement, FCC 15.317, 15.203

In this arrangement the EUT fulfils the requirements of FCC 15.203.

|  |                                     |
|--|-------------------------------------|
| This unit uses internal antennas .<br>There is no provision for an external antenna.                     | <input checked="" type="checkbox"/> |
| This unit uses an unique antenna jack for connection to<br>dedicated external antenna                    | <input type="checkbox"/>            |
| This unit has an external antenna which is fix attached.   | <input type="checkbox"/>            |
| This unit with its antenna will be professionally installed as<br>described in manufacturer description. | <input type="checkbox"/>            |

Comment: See Appendix A for pictures.

### 3.6 Modulation techniques, FCC 15.319 (b)

The test sample is an isochronous digital modulated device that operates in 1920-1930 MHz band.

This device bases on DECT technology described in European Standards EN 300 175-2 and EN 300 175-3, now operating in frequency channels mentioned before on sub-clause 1.5.

The operating modes are MC/TDMA/TDD (Multi carrier / Time Division Multiple Access / Time Division Duplex) using Digital GFSK modulation.

For further details see operational description provided by manufacturer.



### 3.7 Emission band width, FCC 15.323 (a)

Emission band width is measured according to ANSI 63.17 sub-clause 6.1.3 using test set-up no. 1. See Appendix F for measurement diagrams.

| $f_x = 1921.54 \text{ MHz}$ |             |              |                                     |
|-----------------------------|-------------|--------------|-------------------------------------|
| $\Delta P$                  | $f_{(low)}$ | $f_{(high)}$ | $\Delta f = f_{(high)} - f_{(low)}$ |
| -26                         | 1920.78     | 1922.26      | 1.48                                |
| -12                         | 1920.95     | 1922.08      | 1.13                                |
| -6                          | 1921.04     | 1921.88      | 0.84                                |

| $f_x = 1924.99 \text{ MHz}$ |             |              |                                     |
|-----------------------------|-------------|--------------|-------------------------------------|
| $\Delta P$                  | $f_{(low)}$ | $f_{(high)}$ | $\Delta f = f_{(high)} - f_{(low)}$ |
| -26                         | 1924.24     | 1925.71      | 1.47                                |
| -12                         | 1924.40     | 1925.49      | 1.09                                |
| -6                          | 1924.57     | 1925.32      | 0.75                                |

| $f_x = 1928.45 \text{ MHz}$ |             |              |                                     |
|-----------------------------|-------------|--------------|-------------------------------------|
| $\Delta P$                  | $f_{(low)}$ | $f_{(high)}$ | $\Delta f = f_{(high)} - f_{(low)}$ |
| -26                         | 1927.70     | 1929.18      | 1.48                                |
| -12                         | 1927.88     | 1928.98      | 1.10                                |
| -6                          | 1927.98     | 1928.86      | 0.88                                |

Limit:

|  |
|--|
| $\Delta f_{\min} (-26\text{dB}) > 50 \text{ KHz}$  |
| $\Delta f_{\max} (-26\text{dB}) < 2.5 \text{ MHz}$ |

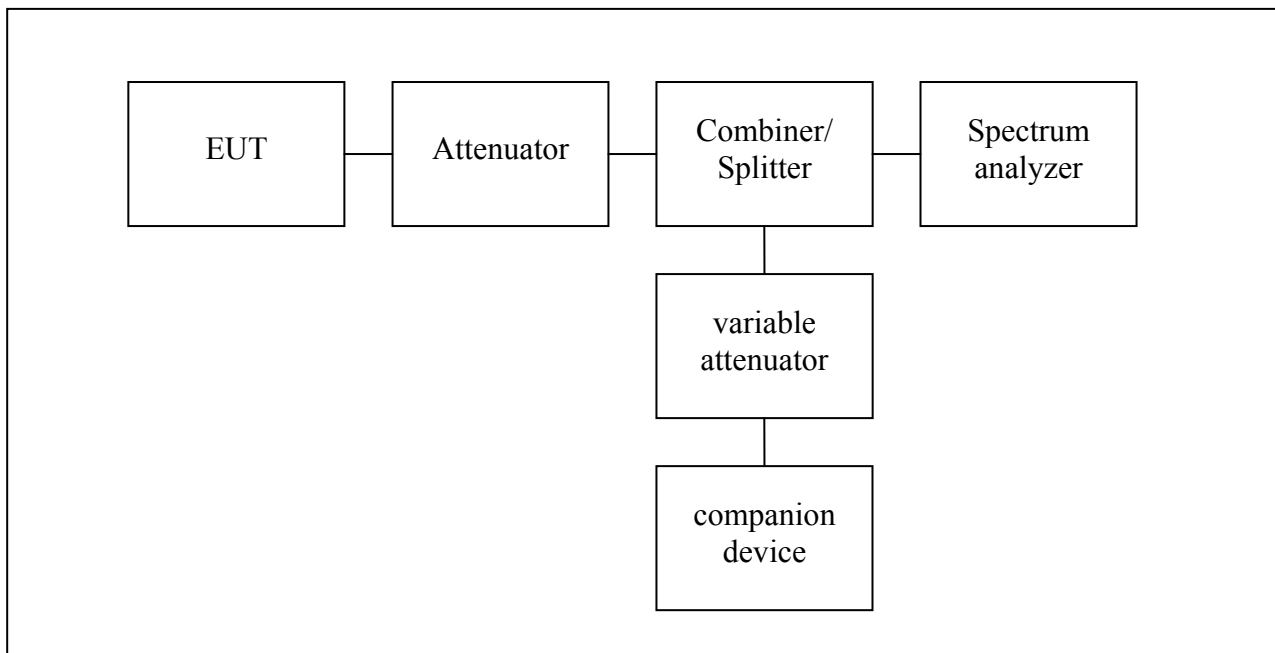

Test set-up 1 – Equipment configuration for conducted RF tests

Test equipment used: ETS 0990, ETS 0492, ETS 0495, ETS 0496, ETS 0502

### 3.8 Peak Transmit Power, FCC 15.319 (c), FCC 15.31 (e)

The Peak transmit Power is measured according to ANSI 63.17 sub-clause 6.1.2. using test set-up No. 1.

The limit for Peak Transmit Power has to be calculated according to following formula using the emission band width measured before and the directional antenna gain.

$$\text{when } G_A \leq g \quad \begin{aligned} \text{PTP} &= 100\mu\text{W} \times \sqrt{\text{EBW}} \\ \text{PTP} &= 100\mu\text{W} \times \sqrt{\text{EBW} - (G_A - g)} \end{aligned}$$

EBW = emission band width [Hz]

$G_A$  = EUT antenna gain [dBi]

$g$  = Allowable excess gain over that of an isotropic antenna without a transmit power reduction [ $g = 3$  dB, acc. to FCC 15.319 (e)]

Additionally the directional gain of used antenna [FCC 15.319(e)] has to be considered.

The test is performed with the variation of supply voltage of +/- 15% for FP. For PP a full battery is used.

Results:

On the attached diagrams PEAK AVG re presents the related measurement value determined by values in time between T1 and T2.

| Frequency [MHz] | Power [dBm]          |                      |                      |
|-----------------|----------------------|----------------------|----------------------|
|                 | for $U_{\text{nom}}$ | for $U_{\text{max}}$ | for $U_{\text{min}}$ |
| $F_L$           | 20.65                | --                   | --                   |
| $F_M$           | 20.60                | --                   | --                   |
| $F_H$           | 20.60                | --                   | --                   |

Limit:

| EBW [Hz]  | Max. power [dBm] | Corrected by antenna gain > 3 dBi |
|-----------|------------------|-----------------------------------|
| 1.480.000 | 20.85            | 20.85                             |

Comment: See Appendix G for measurement diagrams.

### 3.9 Power spectral density, FCC 15.319 (d)

Power spectral density is measured according to ANSI 63.17 sub-clause 6.1.5 using test set-up No. 6.1.

Max Hold function is applied to Max Peak detector with used sweep time as long as no changes on the curve are visible.

Results:

| Frequency [MHz] | Power density [mW/3kHz] |
|-----------------|-------------------------|
| $F_L$           | 1.74                    |
| $F_M$           | 1.61                    |
| $F_H$           | 0.97                    |

Limit:

| Power spectral Density | Test condition   |
|------------------------|------------------|
| 3 mW = 4.77 dBm        | 3 kHz band width |

Comment: See Appendix H for measurement diagrams.

### 3.10 Directional gain of the antenna, FCC 15.319 (e)

Directional gain of antennas influences the limit of peak transmit power if the maximum directional gain exceeds 3 dBi.

| Max antenna gain [dBi] | Exceeds 3 dBi by amount [dB] |
|------------------------|------------------------------|
| 2                      | 0                            |

The antenna gain value is derived from:

|                                  |                                     |
|----------------------------------|-------------------------------------|
| Manufacturer declaration         | <input checked="" type="checkbox"/> |
| Antenna diagram                  | <input type="checkbox"/>            |
| Measured gain of complete system | <input type="checkbox"/>            |

Comment: Manufacturer declaration documents or Antenna diagrams will be considered in course of certification by responsible authority.

### 3.11 Automatic discontinuation of transmission; FCC 15.319(f)

|                                 |                                     |
|---------------------------------|-------------------------------------|
| FP repetitive codes are allowed | <input type="checkbox"/>            |
| PP                              | <input checked="" type="checkbox"/> |

Automatic break off the transmission means break off of connection and break of transmissions which are not control and signaling information or receptive codes of complete frame or burst intervals. In case of devices using basics of DECT technology at least fixed parts and repeaters are using control and signaling information without direct connection to their remote station.

| Evaluation                             |                                     | Verdict |
|--|-------------------------------------|---------|
| Test according to a)                   | <input type="checkbox"/>            |         |
| Assessment of manufacturer declaration | <input checked="" type="checkbox"/> | pass    |

a) The tests are done after establishment of a connection to counter part.

|   | Test case                     | Reaction of EUT | Verdict |
|---|-------------------------------|-----------------|---------|
| 1 | Switch – off counterpart      | A               | pass    |
| 2 | Hook-on by counterpart        | A               | pass    |
| 3 | Switch- off by EUT            | A               | pass    |
| 4 | Hook -on on EUT side          | A               | pass    |
| 5 | Remove power from EUT         | A               | pass    |
| 6 | Remove power from counterpart | A               | pass    |

A – Connection break down, cease of transmit

B – Connection break down, EUT transmits signaling information

C – Connection break down, counter part transmits signaling information

### 3.12 Radio frequency radiation exposure; FCC 15.319(i)

Consideration of radio frequency radiation exposure for EUT is done as

|   |                                     |
|---|-------------------------------------|
| SAR test acc. IEEE 1528 (for PP)            | <input checked="" type="checkbox"/> |
| MPE calculation as below (for FP, Repeater) | <input type="checkbox"/>            |

SAR test results: See SAR test report no. G0M20505-9482-S-8 provided by ETS Dr. Genz GmbH.

MPE calculation: not applicable

The EUT is considered as a mobile device according to OET Bulletin 65, Edition – 97 – 01. Therefore distance to human body of min. 20 cm is determined.

The limit of Power density for General Population / Uncontrolled Exposure is 1.0 mW/cm<sup>2</sup>.

Formula:

$$S = \text{EIRP} / 4\pi R^2$$

Calculation:

|      |                                     |    |
|------|-------------------------------------|----|
| EIRP | Radiated Power [dBm]                | -- |
| EIRP | Radiated Power [mW]                 | -- |
| R    | Distance [cm]                       | -- |
| S    | Power Density [mW/cm <sup>2</sup> ] | -- |

Result:

The EUT complies with the radio frequency radiation exposure requirement.

Comment: Not required.

### 3.13 Monitoring of threshold; Least interfered channel, FCC 15.323 (c)(2); (c)(5); (c)(9)

Monitoring threshold is measured according to Revision Draft 1.1 ANSI 63.17 sub-clause 7.3.1.1 using test set-up No. 2.

This test set-up is used for most tests related to monitoring.

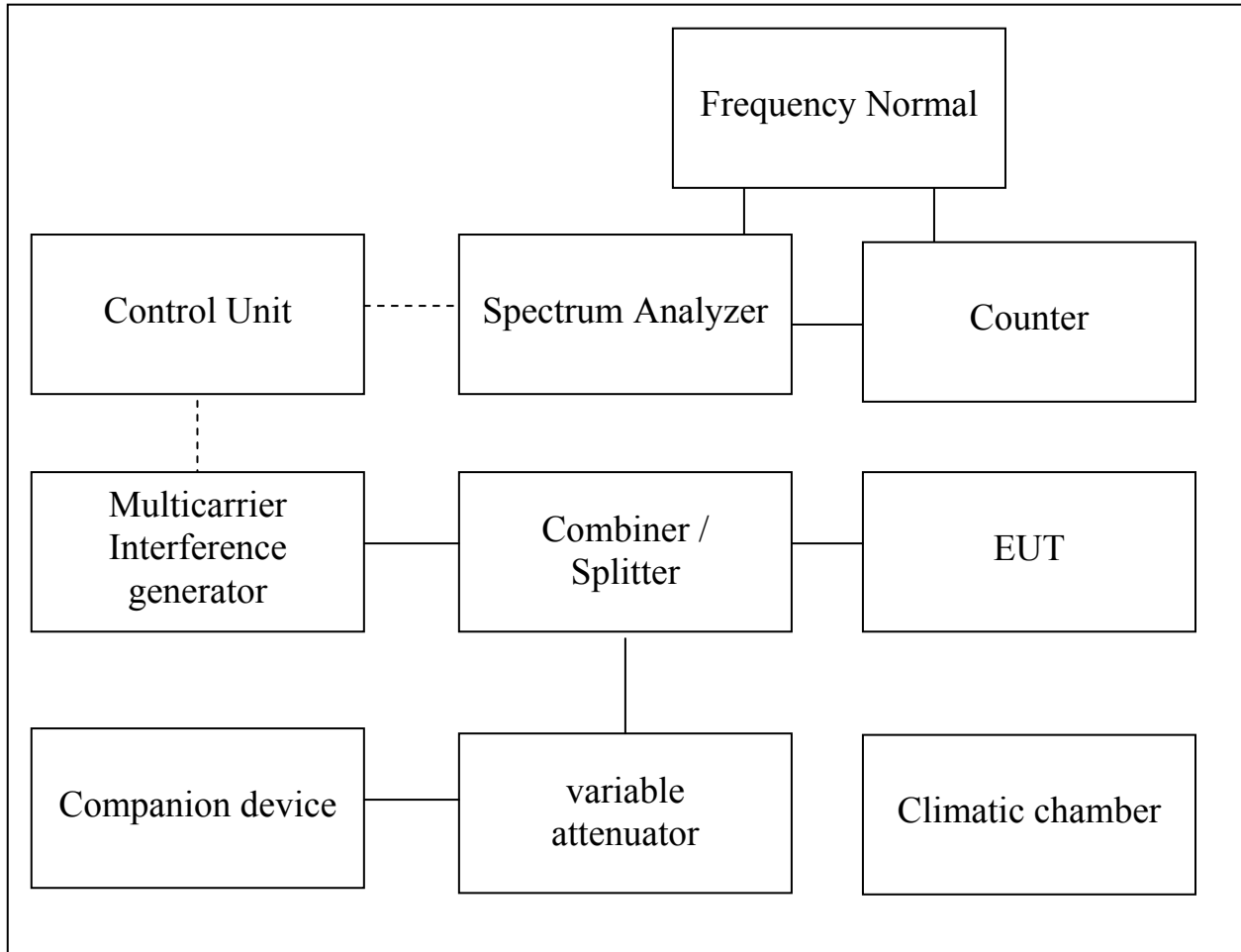

Test set-up 2 Equipment configuration for monitoring tests

Monitoring tests generally determine the lower and upper threshold of the EUT , and verify that if the EUT is operating in the “least-interfered channel” mode, it can properly select the channel with the lowest interference power, within a 6 dB resolution. The “preferred” end of the 1920-1930 MHz band denotes the end at which the search for channels with interference below the lower threshold shall begin. For devices with an emission band width of less than 625 kHz, the search shall begin within 3 MHz , of the lower end of the band (i.e., 1920 MHz). For device with an emission band width of greater than 625 kHz, the search shall begin within 3 MHz of the upper end of the band.

Test equipment used: ETS 0496, ETS 0495, ETS 0267, ETS 0273, ETS 0500, ETS 0501, ETS 0502, ETS 0497, ETS 0498, ETS 0105, ETS 0312, ETS 0224 C



Calculation of monitoring threshold limits for isochronous devices:

Lower threshold:

$$T_L = 15 \log_{10} B - 184 + 30 - P \quad (\text{dBm})$$

Upper threshold:

$$T_H = 15 \log_{10} B - 184 + 50 - P \quad (\text{dBm})$$

$$\begin{array}{l} B = \text{emission bandwidth (Hz)} \\ P = \text{transmitted power (dBm)} \end{array} \quad \left. \begin{array}{l} \} \\ \} \end{array} \right\} \text{measured values}$$

calculated thresholds:

|                       |        |
|-----------------------|--------|
| lower threshold [dBm] | - 82.1 |
| upper threshold [dBm] | - 62.1 |

The upper threshold is applicable for systems which have defined a minimum of 40 duplex system access channels.

Measurement procedure:

For devices without LIC procedure:

For a not or defined interfered band the system will initiate a connection on channel with the lowest level.

After that interferer level on this channel will be increased by 1dB steps, until a new connection on an other channel will established. The related interferer level represents the measured lower threshold.

For devices supporting LIC (least interferer channel) procedure:

Except of two channels ( $f_1$ ;  $f_2$ ) all other channels are blocked by interferers at levels of 20 dB above the lower limit. Then interferers apply to  $f_1$  and  $f_2$  with dedicated levels related to calculated lower threshold according to Revision Draft ANSI 63.17 sub-clause 7.3.1.1.2, check the behavior and repeat each test case 5 times. If the behavior is correct all times, the test is passed.

Upper threshold (for > 40 channels):

An interferer level of about 10 dB above calculated upper threshold is applicable on all system carriers. The interference level is uniformly decreased on all carriers until the EUT starts to transmit. This level is upper threshold.

Results:

|                          |      |
|--------------------------|------|
| Least interfered channel | Pass |
| Lower threshold [dBm]    | n.a. |
| Upper threshold [dBm]    | -60  |

Limits:

|              |                                     |                    |
|--------------|-------------------------------------|--------------------|
| Used results | Emission band width [MHz]           | 1.48               |
|              | Peak transmit power [dBm]           | 20.65              |
| Limits       | Lower threshold [dBm] + 6 dB margin | - 82.1 ... - 76.1  |
|              | Upper threshold [dBm] + 6 dB margin | - 62..1 ... - 56.1 |

Comment: For LOG tables and measurement diagrams see Appendix K.

### 3.14 Monitoring of intended transmit window and maximum reaction time, FCC 15.323 (c) (1)

Monitoring of intended transmit window is tested according to ANSI 63.7 sub-clause 7.5 using test set-up No. 2.

These tests are related to isochronous reaction time and monitoring interval.

The reaction time is the duration of the RF power, during the monitoring interval, that shall be detected by the device to determine that the monitored time and spectrum window is occupied.

The objective of the test is to demonstrate that the device defers use of a region of spectrum when the interfering signals are of a time duration that exceeds the allowed limit.

If the sample fulfills the requirements of reaction time it shows that it has monitored the intended transmit window.

Test c:

With the channel interferer level at the calculated threshold limit, plus a 6dB margin verify that the EUT does not establish a connection when the width of the interference pulse exceeds the largest of 50  $\mu$ s and  $50 \sqrt{1.25/B}$   $\mu$ s.

B-Emission band width of EUT in MHz

Test d:

With the channel interferer set to a level that is 6 dB above the calculated threshold limit, plus a 6 dB margin, verify that no connection occurs with a interference pulse width which exceeds the largest of 35  $\mu$ s and  $35 \sqrt{1.25/B}$   $\mu$ s.

Test e:

Increase the pulse duration to the largest of 75  $\mu$ s and  $75 \sqrt{1.25/B}$   $\mu$ s. Set the interference power to a level 10 dB above the calculated upper threshold limit plus a 6dB margin and randomly vary the synchronization of the pulsed interference generator with respect to the EUT frame. Verify that the EUT does not transmit.

Results:

| Pulse width                              | Connection     |                |                |
|--|----------------|----------------|----------------|
|  | F <sub>L</sub> | F <sub>M</sub> | F <sub>U</sub> |
| 50 $\mu$ s or $50 \sqrt{1.25/B}$ $\mu$ s | no             | no             | no             |
| 35 $\mu$ s or $35 \sqrt{1.25/B}$ $\mu$ s | no             | no             | no             |
| 75 $\mu$ s or $75 \sqrt{1.25/B}$ $\mu$ s | no             | no             | no             |

Calculation of applied pulse width and maximum reaction time:

For Emission band width > 1,25 MHz the pulse width is always 35  $\mu$ s, 50  $\mu$ s and 75  $\mu$ s

| Used results                             | Emission band width [MHz]      | e.g. 1.47 |
|--|--------------------------------|-----------|
| Max. reaction time<br>and<br>Pulse width | $50 \sqrt{1.25/B} \mu\text{s}$ | 46.1      |
|  | $35 \sqrt{1.25/B} \mu\text{s}$ | 32.3      |
| Pulse width                              | $75 \sqrt{1.25/B} \mu\text{s}$ | 69.2      |

Comment: For examples of LOG tables and measurement diagrams see Appendix L.

### 3.15 Monitoring band width, FCC 15.323 (c)(7)

Monitoring band width is measured according to ANSI 63.17 sub-clause 7.4.1. using test set-up No. 2.

Test procedure:

Center the interfering signal at a frequency above the center of the emission of the EUT, separated by 30% of the emission band width of the EUT, at a level that is 10 dB above the calculated threshold limit. The band width of the interfering signal shall be equal to or greater than the minimum emission band width allowed for the sub-band. It shall be verified that the EUT does not establish a connection. The procedure is repeated with the interference centered at a frequency below the center of the emission of the EUT, separated by 30% of the emission band width of the EUT, at a level that is 10 dB above the calculated threshold limit. It shall be verified that the EUT does not establish a connection.

Results:

|                        |                          |            |
|------------------------|--------------------------|------------|
| Interferer level [dBm] |                          | -78.2      |
| Test frequency         | Interferer frequency     | Connection |
| F <sub>L</sub>         | F <sub>L</sub> - 30 % BW | no         |
|                        | F <sub>L</sub> + 30 % BW | no         |
| F <sub>M</sub>         | F <sub>M</sub> - 30% BW  | no         |
|                        | F <sub>M</sub> + 30 % BW | no         |
| F <sub>U</sub>         | F <sub>U</sub> - 30% BW  | no         |
|                        | F <sub>U</sub> + 30 % BW | no         |

Comment: For LOG tables see Appendix M.

### 3.16 Random waiting interval, FCC 15.323 (c)(6)

Random waiting interval is considered according ANSI 63.17 sub-clause 8.13.

This test applies to an EUT capable of transmitting control and signaling information on its own without companion device.

Sub-clause 8.1.6 limits this test to devices which support the procedure to choose to reselect an unavailable access channel after a random delay between 10-150 ms. This feature may be used by systems not utilizing the provisions of 15.323 (c)(5), e.g. single carrier systems.

It is measured the time interval between the end of the EUT transmission and the beginning of transmission by the EUT.

Test set-up No. 1 is used.

Comment: This test is not applicable for this EUT.

**3.17 Duration of Transmission, FCC 15.323 (c)(3)**

Duration of Transmission (Maximum transmit period) is measured according to ANSI 63.17 sub-clause 8.2.2 using test set-up No. 1.

Result:

|                           |            |
|---------------------------|------------|
| Maximum transmission time | 5 h 15 min |
|---------------------------|------------|

Limit:

|                               |     |
|-------------------------------|-----|
| Maximum transmission time [h] | < 8 |
|-------------------------------|-----|

Comment: For LOG tables see Appendix O.  
For DECT based technology the PP is the initiating device and determines duration of transmission.

### 3.18 Connection acknowledgement; Unacknowledged transmission; FCC 15.323 (c)(4)

Connection acknowledgements are tested according to ANSI 63.17 sub-clause 8.2.1 , Unacknowledged transmission following sub clause 8.1.3.

#### Unacknowledged transmission:

Results:

| Requirement                                       | Time | Verdict |
|---|------|---------|
| Change of access criteria for control information | --   | n.a     |
| Pause length                                      | --   | n.a     |
| Change of access channel                          | --   | n.a     |

Limits:

| Requirement                                       | Value     |
|---|-----------|
| Change of access criteria for control information | 30 s      |
| Pause length                                      | > 10 ms   |
| Change of access channel                          | mandatory |

#### Connection acknowledgement

| Requirement                 | Time  | Verdict |
|-----------------------------|-------|---------|
| Connection acknowledgement  | 5 ms  | pass    |
| Termination of transmission | 3.7 s | pass    |

Limits:

| Requirement                 | Value |
|-----------------------------|-------|
| Connection acknowledgement  | 1 s   |
| Termination of transmission | 30 s  |

Comment: For LOG tables see Appendix P.



### 3.19 Selected channel confirmation, power accuracy, segment occupancy; FCC 15.323 (c)(5)

#### Selected channel confirmation:

This test is done according to Revision Draft 1.1 ANSI 63.17 sub-clause 7.3.1.2 using test set-up No. 2.

Results:

| Test | Transmit on $f_1$ | Transmit on $f_2$ | Verdict |
|------|-------------------|-------------------|---------|
| c    | yes               | no                | pass    |

#### Power accuracy

The power measurement resolution for the previous comparisons must be accurate to within 6 dB. This requirement was proved automatically by testing of monitoring thresholds according to FCC 15.323 (2); 3.13.

#### Segment occupancy

| Document                  | available                           | sufficient                          |
|---------------------------|-------------------------------------|-------------------------------------|
| Manufacturers declaration | <input checked="" type="checkbox"/> | <input checked="" type="checkbox"/> |
| Technical description     | <input type="checkbox"/>            | <input type="checkbox"/>            |

Comment: See attached diagrams in Appendix Q.

**3.20 Monitoring antenna, FCC 15.323 (c)(8)**

The monitoring system shall use the same antenna used for transmission or an antenna that yields equivalent reception.

|                                  |                                     |
|----------------------------------|-------------------------------------|
| System uses same antenna(s)      | <input checked="" type="checkbox"/> |
| System uses different antenna(s) | <input type="checkbox"/>            |

If the monitoring antenna is different from the transmitting antenna, it shall be verified that the monitoring antenna provides coverage equivalent to that of the transmitting antenna.

The related tests are to perform according to ANSI 63.17 sub-clause 4 using test set-up No. 3.

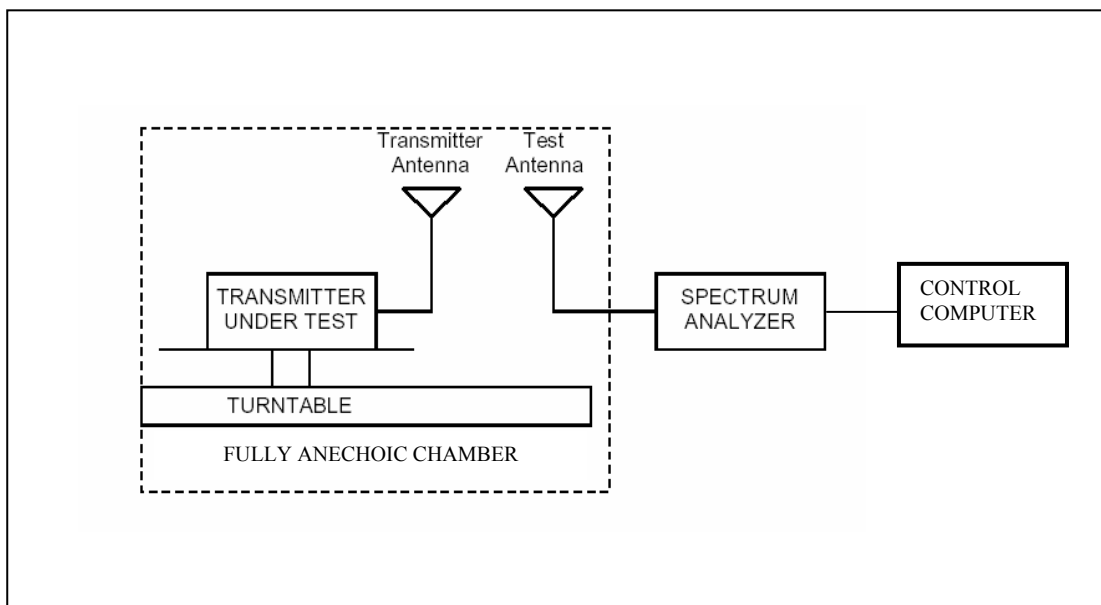

Test set-up 3 Equipment configuration for radiated tests

Test equipment used: ETS 0012, ETS 0013, ETS 0014, ETS 0031, ETS 0253, ETS 0310

### 3.21 Duplex connections, FCC 15.323 (c)(10)

This test verifies that the two devices communicating over a duplex connection comply with the access criteria.

The test is done according to Revision Draft ANSI 63.17 sub-clause 8.2.1 using test set-up No. 2.

Test 3.

The test proves the basic conditions for the following tests. The out-of-operating-region interference is used to confine the EUT to the band.

Test 3. – 11.

The interference levels at the companion device are at least 10 dB below the measured lower threshold.

Test 4. and 5. (< 40 channels)

This test proves whether a connection can be established with interferences at 6 dB above calculated lower threshold level in transmit window and receive window in which one slot is free of interferences.

For system with less than 40 channels a connection is not allowed.

Test 6. and 7. (< 40 channels)

This test proves whether a connection can be established with interferences at 6 dB above calculated lower threshold level in receive window and transmit window in which one slot is free of interferences.

For systems with less than 40 channels a connection is not allowed.

Test 8. and 9. ( $\geq$  40 channels)

For this test the transmit window is interfered with a level of +6 dB above the calculated lower threshold except for one slot which is free.

The receive window is interfered with a level of +13dB above the calculated lower threshold only except for one slot which is free.

A connection shall be established on the free receive slot and its duplex mate.

Test 10. and 11. ( $\geq$  40 channels)

The receive window is interfered with a level of +6 dB above the calculated lower threshold except for one slot which is free.

The transmit window is interfered with a level of +13 dB above the calculated lower threshold only except for one slot and its duplex mate.

Test 12. ( $\geq$  40 channels)

For this test both windows are interfered with a level of 6 dB above the calculated upper threshold except one slot in each window.

The received signal to the EUT from companion device is at least 30 dB above the upper threshold.

A connection shall not be established.

| Test    | applicable                          | Connection                          | No connection                       | verdict |
|---------|-------------------------------------|-------------------------------------|-------------------------------------|---------|
| 3       | <input checked="" type="checkbox"/> | <input checked="" type="checkbox"/> | <input type="checkbox"/>            | pass    |
| 4 + 5   | <input type="checkbox"/>            | <input type="checkbox"/>            | <input type="checkbox"/>            |         |
| 6 + 7   | <input type="checkbox"/>            | <input type="checkbox"/>            | <input type="checkbox"/>            |         |
| 8 + 9   | <input checked="" type="checkbox"/> | <input checked="" type="checkbox"/> | <input type="checkbox"/>            | pass    |
| 10 + 11 | <input checked="" type="checkbox"/> | <input checked="" type="checkbox"/> | <input type="checkbox"/>            | pass    |
| 12      | <input checked="" type="checkbox"/> | <input type="checkbox"/>            | <input checked="" type="checkbox"/> | pass    |

Comment: See attached diagrams in Appendix R.

**3.22 Alternative monitoring interval for co-located devices, FCC 15.323 (c)(11)**

Alternative monitoring interval for co-located devices may be tested according ANSI 63.17 sub-clause 8.2.4 using test set-up No. 2.

Results.

The manufacturer declares that this provision is not utilized by the EUT.

**3.23 Fair access to spectrum related to (c)(10) and (c)(11), FCC 15.323 (c)(12)**

The provisions of (c)(10) or (c)(11) shall not be used to extend the range of spectrum occupied over space or time for the purpose of denying fair access to spectrum to other devices.

The manufacturer declares that is device does not work in a mode which denies fair access to spectrum for other participants.

### 3.24 Emissions inside and outside the sub-band, FCC 15.323 (d)

Emission inside and outside the sub-band are tested according to ANSI 63.17 sub-clauses 6.1.6.1 and 6.1.6.2.

Determination of measurement band width:

$$BT_T = \text{approx. } 1\% \text{ of } B$$

|                  |                             |      |
|------------------|-----------------------------|------|
| Used results     | Emission band width [MHz]   | 1.48 |
| Calculated value | Resolution band width [kHz] | 14.8 |
| Determined value | Resolution band width [kHz] | 10   |

#### Emissions inside the sub-band

Testing of emissions inside the sub-band are performed using test set-up No.1.  
The applied emission mask limit was created using the current emission band width.

Comment: For results see diagrams in Appendix S.

#### Emissions outside the sub-band

Out of sub band emissions are tested as radiated measurement band width of about 1% of emission band width near the band edges and at critical frequencies where the measurement values come near the limits. For practical reasons other frequencies the more stringent band width of 1 MHz is used.

As test environment serves a fully anechoic chamber providing a free space environment (test set-up No. 3)

All results will be updated by an automatic measuring system in accordance with point 2.3.

Calculation of test results:

Such factors like antenna correction, cable loss, external attenuation etc. are already included in the provided measurement results. This is done by using validated test software and calibrated test system according the accreditation requirements.

The significant peak and average values are listed in the tables below showing the compliance with the above calculated limits.

Remark: Both versions (4040 and 4020) are considered related to their radiated spurious emissions and have passed the test.

## Summary table with radiated data of the test plots

| Freq. | Used Ch. | Frequency Marker [GHz] | Polarization | $\Delta$ corrections dB | Max. Power level [dBm] | Compliance Limit [dBm] | Detector | BW [MHz] | Margin [dB]  |
|-------|----------|------------------------|--------------|-------------------------|------------------------|------------------------|----------|----------|--------------|
| 3     | L        | 3.844                  | V            |                         | -44.91                 | -39.5                  | P        | 1        | <u>-5.41</u> |
| 3     | L        | 3.844                  | H            |                         | -49.15                 | -39.5                  | P        | 1        | <u>-9.65</u> |
| 4     | L        | 7.689                  | V            |                         | -42.11                 | -39.5                  | P        | 1        | <u>-2.61</u> |
| 4     | L        | 7.684                  | H            |                         | -43.26                 | -39.5                  | P        | 1        | <u>-3.76</u> |
| 5     | L        | 11.533                 | V            |                         | -40.89                 | -39.5                  | P        | 1        | <u>-1.39</u> |
| 5     | L        | 11.527                 | V            |                         | -42.75                 | -39.5                  | P        | 0.01     | <u>-3.25</u> |
| 5     | L        | 11.529                 | H            |                         | -42.25                 | -39.5                  | P        | 1        | <u>-2.75</u> |
| 5     | L        | 11.527                 | H            |                         | -40.06                 | -39.5                  | P        | 0.01     | <u>-0.56</u> |
| 4     | M        | 7.702                  | V            |                         | -33.36                 | -39.5                  | P        | 1        |              |
| 4     | M        | 7.699                  | V            |                         | -42.89                 | -39.5                  | P        | 0.01     | <u>-3.39</u> |
| 4     | M        | 7.702                  | H            |                         | -43.52                 | -39.5                  | P        | 1        | <u>-4.02</u> |
| 5     | M        | 11.551                 | V            |                         | -40.10                 | -39.5                  | P        | 1        | <u>-0.60</u> |
| 5     | M        | 11.552                 | V            |                         | -44.35                 | -39.5                  | P        | 0.01     | <u>-4.85</u> |
| 5     | M        | 11.551                 | H            |                         | -33.07                 | -39.5                  | P        | 1        |              |
| 5     | M        | 11.548                 | H            |                         | -41.50                 | -39.5                  | P        | 0.01     | <u>-2.0</u>  |
| 3     | H        | 3.858                  | V            |                         | -43.32                 | -39.5                  | P        | 1        | <u>-3.82</u> |
| 3     | H        | 3.858                  | H            |                         | -46.82                 | -39.5                  | P        | 1        | <u>-7.32</u> |
| 4     | H        | 7.711                  | V            |                         | -42.09                 | -39.5                  | P        | 1        | <u>-2.59</u> |
| 4     | H        | 7.711                  | H            |                         | -41.91                 | -39.5                  | P        | 1        | <u>-2.41</u> |
| 5     | H        | 11.569                 | V            |                         | -33.06                 | -39.5                  | P        | 1        |              |
| 5     | H        | 11.569                 | V            |                         | -42.33                 | -39.5                  | P        | 0.01     | <u>-2.83</u> |
| 5     | H        | 11.573                 | H            |                         | -33.11                 | -39.5                  | P        | 1        |              |
| 5     | H        | 11.569                 | H            |                         | -40.94                 | -39.5                  | P        | 0.01     | <u>-1.44</u> |
| 6     | H        | 13.500                 | V            |                         | -42.62                 | -39.5                  | P        | 1        | <u>-3.12</u> |
| 6     | H        | 13.500                 | V            |                         | 43.69                  | -39.5                  | P        | 1        | <u>-4.19</u> |

## Freq. – Frequency Range:

|    |     |   |          |
|----|-----|---|----------|
| 1: | 30  | – | 200 MHz  |
| 2: | 200 | – | 1000 MHz |
| 3: | 1   | – | 4 GHz    |
| 4: | 4   | – | 8 GHz    |
| 5: | 8   | – | 12 GHz   |
| 6: | 12  | – | 17 GHz   |
| 7: | 17  | – | 26.5 GHz |

Comment: For diagrams see Appendix S.

### 3.25 Frame period, FCC 323 (e)

Frame repetition stability is tested according to ANSI 63.17 sub-clause 6.2.3. Frame period and jitter are tested following ANSI 63.17 sub-clause 6.2.4. For all measurement test set-up No.1 is used.

#### Frame repetition stability:

The spectrum analyzer is used as an envelope detector and provides gating signals to a frequency counter.

The obtained frequency values are computed to get mean value, deviation and frame repetition stability. Frame repetition stability is three times of the standard deviation SD.

Results:

| Frequency (MHz) | Standard Deviation (Hz) | Mean(Hz)    | Frame Repetition Stability (ppm) |
|-----------------|-------------------------|-------------|----------------------------------|
| 1924,992        | 1.92927E-06             | 99.99999837 | 0.058                            |

Limits:

| Time division mode | Frame repetition stability | applicable                          |
|--------------------|----------------------------|-------------------------------------|
| TDA                | 50 ppm                     | <input type="checkbox"/>            |
| TDMA               | 10 ppm                     | <input checked="" type="checkbox"/> |

#### Frame period and jitter:

Frame period and jitter test the spectrum and modulation is used to obtain the time duration between rising edges. These measurement value are used to compute the difference between any two consecutive frame periods (jitter).

The measured mean time is the frame period.

Results:

| Frequency (MHz) | Max. jitter [ $\mu$ s] | 3xSD jitter [ $\mu$ s] | Frame period [ms] |
|-----------------|------------------------|------------------------|-------------------|
| 1924,992        | 0.156                  | 0.468 <sup>1)</sup>    | 10.00000016       |



Limits:

|   |            |
|---|------------|
| Frame period [ms]   | 20 or 10/x |
| Max. jitter [ $\mu$ s]  | 25         |
| 3 times the standard deviation SD [ $\mu$ s]<br>value of jitter <sup>2)</sup> | 12.5       |

<sup>2)</sup> This item is not required by FCC 15.323(e).

Comment: For example measurement sheet of frame period see Appendix T.

**3.26 Frequency stability, FCC 323 (f)**

Frequency stability is measured by spectrum analyzer in modulation mode.  
The procedure is carried out with conditions shown in result table.

|                           |                          |                                     |
|---------------------------|--------------------------|-------------------------------------|
| This sample is powered by | wired supply             | battery                             |
|                           | <input type="checkbox"/> | <input checked="" type="checkbox"/> |

Results:

| Temp °C | Supply Voltage | Frequency of carrier (MHz) | delta f(min) (KHz) | delta f(max) (KHz) | maximum delta f (ppm) | Mean (MHz)  | Deviation ppm |
|---------|----------------|----------------------------|--------------------|--------------------|-----------------------|-------------|---------------|
| 20      | Vnom           | 1924,992                   | -61,378            | 2,562              | -31,88                | 1924,960837 | Reference     |
| -10     | Vnom           | 1924,992                   | -46,646            | 23,307             | -24,23                | 1924,978135 | -8,99         |
| 55      | Vnom           | 1924,992                   | -78,659            | 52,07              | -40,86                | 1924,950845 | 5,19          |

Limit : 10 ppm

$$Deviation\ ppm = \frac{FR - FM}{FR} * 10^6$$

FR = Reference frequency of carrier at 20°C and V<sub>nom</sub>

FM = Measured frequency of carrier

Limit:

| Temperature [°C]          | Supply voltage           | Frequency deviation [ppm] |
|---------------------------|--------------------------|---------------------------|
| 20                        | 85-115% or new batteries | Reference / 10            |
| -20                       | Normal                   | 10                        |
| +50                       | Normal                   | 10                        |
| Others <sup>1)</sup> - 10 | Normal                   | 10                        |
| Others <sup>1)</sup> + 55 | Normal                   | 10                        |

<sup>1)</sup> declared by manufacturer

Comment: For histograms see Appendix U.

## Appendix

|   |  |
|---|--|
| A | Pictures   |
| B | Coordination with fixed microwave service                        |
| C | Reference to Subpart B   |
| D | Labeling requirements  |
| E | Conducted limits AC Power line                                   |
| F | Emission band width  |
| G | Peak Transmit Power  |
| H | Power spectral density   |
| I | Directional gain of the antenna                                  |
| J | Radio frequency radiation exposure                               |
| K | Monitoring threshold   |
| L | Monitoring of intended transmit window and maximum reaction time |
| M | Monitoring band width  |
| N | Random waiting interval  |
| O | Duration of Transmission   |
| P | Connection acknowledgement                                       |
| Q | Selected channel confirmation, power accuracy, segment occupancy |
| R | Duplex connections   |
| S | Emissions inside and outside the sub-band                        |
| T | Frame period   |
| U | Frequency stability  |