



EUROFINS PRODUCT SERVICE GMBH



Testing Cert #1983.01

# TEST- REPORT

**Compliance Test Report**

**FCC PART 15 SUBPART C  
IC RSS 210 ISSUE 7**

**Bluetooth Radio Part**

**FCC ID: PXA-PP6P-67XX  
IC: 1849C-PP6P67XX**

**DECT Telephone Handsets**

**60xx and 70xx**

**TEST REPORT NUMBER: G0M21006-3316-P-15**



Eurofins Product Service GmbH  
Storkower Str. 38c, 15526 Reichenwalde,  
Germany

Phone +49-33631-888 0  
Fax +49-33631-888 660

## TABLE OF CONTENTS

<b>1</b>	<b>General Information</b>	<b>4</b>
1.1	Notes	4
1.2	Testing laboratory	5
1.3	Details of approval holder	6
1.4	Application details	6
1.5	Test item	6
1.6	Test standards	7
1.7	Acronyms and abbreviations	7
<b>2</b>	<b>Technical test</b>	<b>8</b>
2.1	Summary of test results	8
2.2	Test environment	8
2.3	Test equipment utilized	9
2.4	Sample emission level calculation	10
2.5	Test results	11
<b>3</b>	<b>Informational Transmitter parameters</b>	<b>12</b>
3.1	Transmitter Modes for conformance testing	12
3.2	Occupied Bandwidth	13
<b>4</b>	<b>Transmitter parameters</b>	<b>15</b>
4.1	20dB Bandwidth	15
4.2	Frequency hopping channel number	17
4.3	Frequency hopping channel spacing	19
4.4	Time of occupancy (Dwell time)	21
4.5	Maximum peak conducted output power	23
4.6	Maximum e.i.r.p. output power	25
4.7	Transmitter band-edge compliance	27
4.8	Transmitter conducted spurious emissions	29
4.9	Transmitter radiated spurious emissions	31
<b>5</b>	<b>Receiver parameters</b>	<b>34</b>
5.1	Receiver spurious emissions	34
<b>6</b>	<b>Power Line parameters</b>	<b>36</b>
6.1	AC power line conducted emissions	36

<b>Annex A</b>	<b>Photos</b>	<b>37</b>
<b>Annex B</b>	<b>Transmitter occupied bandwidth</b>	<b>48</b>
<b>Annex C</b>	<b>Transmitter 20dB bandwidth</b>	<b>51</b>
<b>Annex D</b>	<b>Hopping channels</b>	<b>54</b>
<b>Annex E</b>	<b>Hopping channel separation</b>	<b>58</b>
<b>Annex F</b>	<b>Time of occupancy</b>	<b>59</b>
<b>Annex G</b>	<b>AC Powerline Conducted Emissions</b>	<b>61</b>
<b>Annex H</b>	<b>Transmitter conducted spurious emissions</b>	<b>69</b>
<b>Annex I</b>	<b>Band edge compliance</b>	<b>78</b>
<b>Annex J</b>	<b>Transmitter radiated spurious emissions</b>	<b>82</b>
<b>Annex K</b>	<b>Receiver radiated spurious emissions</b>	<b>109</b>

# 1 General Information

## 1.1 Notes

The results of this test report relate exclusively to the item tested as specified in chapter "Description of test item" and are not transferable to any other test items.

Eurofins Product Service GmbH is not responsible for any generalisations and conclusions drawn from this report. Any modification of the test item can lead to invalidity of test results and this test report may therefore be not applicable to the modified test item.

The test report may only be reproduced or published in full. Reproducing or publishing extracts of the report requires the prior written approval of the Eurofins Product Service GmbH.

This document is subject to the General Terms and Conditions and the Testing and Certification System of Eurofins Product Service GmbH, available on request or accessible at [www.pt.eurofins.com](http://www.pt.eurofins.com)

### Operator:

30.09.2010

W. Treffke

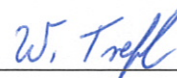

Date

Eurofins-Lab.

Name

Signature

### Technical responsibility for area of testing:

30.09.2010

J. Zimmermann

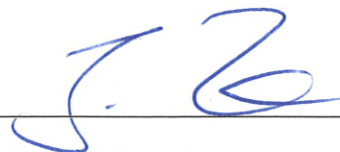

Date

Eurofins

Name

Signature

## 1.2 Testing laboratory

EUROFINS PRODUCT SERVICE GMBH  
Storkower Strasse 38c  
D-15526 Reichenwalde b. Berlin  
Germany  
Telefon : +49 33631 888 00  
Telefax : +49 33631 888 660

**DAR ACCREDITED TESTING LABORATORY**  
DAR-REGISTRATION NUMBER: DAT-P-268/08

**RECOGNIZED NOTIFIED BODY EMC**  
REGISTRATION NUMBER: BNetzA-bS EMV-07/61

**RECOGNIZED NOTIFIED BODY R&TTE**  
REGISTRATION NUMBER: BNetzA-bS-02/51-53

**FCC FILED TEST LABORATORY**  
REG.-No. 96970

**A2LA ACCREDITED TESTING LABORATORY**  
CERTIFICATE No. 1983.01

**BLUETOOTH QUALIFICATION TEST FACILITY (BQTF)**  
ACCREDITED BY BLUETOOTH QUALIFICATION REVIEW BOARD

**INDUSTRY CANADA FILED TEST LABORATORY**  
REG. NO. IC 3470

### Test location, where different:

Name : ./.  
Street : ./.  
Town : ./.  
Country : ./.  
Telephone : ./.  
Fax : ./.

### 1.3 Details of approval holder

Name : Polycom Inc.  
Street : 4750 Willow Road  
Town : Pleasanton, CA, 94588-2708  
Country : USA  
Telephone : +44 1753 723011  
Fax : +44 1600 715 799

Contact : Mr. Tony Griffiths  
E-mail : tony.griffiths@polycom.com

### 1.4 Application details

Date of receipt of application : 29.07.2010  
Date of receipt of test item : 29.07.2010  
Date of test : 26.08.2010 -20.09.2010

### 1.5 Test item

Description of test item : DECT Telephone Handsets  
Type identification : 60xx and 70xx (Family incorporating Kirk 6020, Kirk 6040; Kirk 7010, Kirk 7020 and Kirk 7040)  
Serial number : 00077 09869604  
Equipment type : End product

#### Technical data

Frequency range : 2400 - 2483.5MHz  
Tested frequencies : F<sub>1</sub> 2402MHz  
Tested frequencies : F<sub>2</sub> 2441MHz  
Tested frequencies : F<sub>3</sub> 2480MHz  
Antenna type : internal  
Antenna model : ceramic antenna  
Number of antennas : 1  
Antenna gain : 0dBi (Declared by approval holder)  
Power supply : 3.7VDC 120V AC/DC Adapter  
Operating mode : semi duplex  
Spreading technique : FHSS  
Modulations : GFSK  
Device classification : Portable Device (Human Body distance < 20 cm)

Additional information : The results in this test report cover only the bluetooth radio part of the EUT. The results for the UPCS radio part are given in test-report G0M21006-3316-C-1.

The manufacturer declared that the device Kirk 6020, Kirk 7010, Kirk 7020 and Kirk 7040 are identical to the tested device Kirk 6040. The Kirk 6040 has been selected as worst case device. Therefore only the Kirk 6040 have been tested.

**Manufacturer:**  
(if applicable)

Name : Polycom Inc.  
 Street : 4750 Willow Road  
 Town : Pleasanton, CA, 94588-2708  
 Country : USA

## 1.6 Test standards

Technical standard :  **FCC PART 15 SUBPART C**  
 **IC RSS 210 ISSUE 7**

## 1.7 Acronyms and abbreviations

EUT : Equipment under Test  
 TX : Transmission  
 RX : Reception  
 RBW : Measurement Resolution Bandwidth  
 Pol : Measurement Polarization  
 e.i.r.p. : Equivalent isotropic radiated power  
 FHSS : Frequency hopping spread spectrum  
 DSSS : Direct Sequence Spread Spectrum  
 OFDM : Orthogonal frequency division multiplexing  
 CCK : Complementary code keying  
 GFSK : Gaussian frequency shift keying  
 DQPSK : Differential quadrature phase shift keying  
 PSK : Phase shift keying  
 $T_{nom}$  : Nominal Temperature  
 $T_{min}$  : Minimum Temperature  
 $T_{max}$  : Maximum Temperature  
 $V_{nom}$  : Nominal Supply Voltage  
 $V_{min}$  : Minimum Supply Voltage  
 $V_{max}$  : Maximum Supply Voltage  
 VDC : DC voltage  
 N/A : Not applicable  
 IC : Industry Canada

## 2 Technical test

### 2.1 Summary of test results

No deviations from the technical specification(s) were ascertained in the course of the tests performed.

or

The deviations as specified in 2.4 were ascertained in the course of the tests performed.

### 2.2 Test environment

Temperature : 22 ... 26°C

Relative humidity content : 20 ... 75%

Air pressure : 86 ... 103kPa

Extreme conditions parameters:

$V_{nom}$  : 3.7VDC 120V AC/DC Adapter

$V_{min} (V_{nom}-15\%)$  : -

$V_{max} (V_{nom}+15\%)$  : -

$T_{nom}$  : 25°C

Other parameter: None



## 2.3 Test equipment utilized

Measurement Equipment List					
No.	Measurement device:	Type:	Manufacturer:	Last Cal.	Next Cal.
ETS 0086	Semi-anechoic chamber	AC1	Frankonia	12.03.2010	12.03.2011
ETS 0271	Spectrum Analyzer	FSEK30	Rohde & Schwarz	19.03.2009	19.03.2011
ETS 0012	Biconical Antenna	HK 116	Rohde & Schwarz	29.01.2010	29.01.2011
ETS 0336	LPD Antenna	HL 223	Rohde & Schwarz	28.01.2010	28.01.2011
ETS 0018	Horn Antenna	BBHA 9120D	Schwarzbeck	26.08.2010	26.08.2011
ETS 0432	Amplifier-Matrix			02.06.2010	02.06.2012
ETS 0496	Spectrum Analyzer	FSP30	Rohde & Schwarz	26.08.2010	26.08.2011
ETS 0086	Semi-anechoic chamber	AC1	Frankonia	12.03.2010	12.03.2011

## 2.4 Sample emission level calculation

The following is a description of terms and a sample calculation, as appears in the radiated emissions data table. The numbers used in the calculation are for example only. There is no direct correlation to the specific data taken for the product described in this document:

Reading:

This is the reading obtained on the spectrum analyzer in dB $\mu$ V. Any external preamplifiers used are taken into account through internal analyzer settings.

A.F.:

This is the antenna factor for the receiving antenna. It is a conversion factor, which converts electric fields strengths to voltages, which can be measured directly on the spectrum analyzer. It is treated as a loss in dB. Cable losses have been included with the A.F. to simplify the calculations. The antenna factor is used in calculations as follows:

$$\text{Reading on Analyzer (dB}\mu\text{V)} + \text{A.F. (dB)} = \text{Net field strength (dB}\mu\text{V/m)}$$

Net:

This is the net field strength measurement (as shown above).

Limit:

This is the FCC Class B radiated emission limit (in units of dB $\mu$ V/m). The FCC limits are given in units of  $\mu$ V/m. The following formula is used to convert the units of  $\mu$ V/m to dB $\mu$ V/m:

$$\text{Limit (dB}\mu\text{V/m)} = 20 \cdot \log(\mu\text{V/m})$$

Margin:

This is the margin of compliance below the FCC limit. The units are given in dB. A negative margin indicates the emission was below the limit. A positive margin indicates that the emission exceeds the limit.

Example only:

$$\begin{array}{rclcl} \text{Reading} & + & \text{AF} & = & \text{Net Reading} & : & \text{Net reading} - \text{FCC limit} = \text{Margin} \\ 21.5 \text{ dB}\mu\text{V} & + & 26 \text{ dB} & = & 47.5 \text{ dB}\mu\text{V/m} & : & 47.5 \text{ dB}\mu\text{V/m} - 57.0 \text{ dB}\mu\text{V/m} = -9.5 \text{ dB} \end{array}$$

## 2.5 Test results

 1<sup>st</sup> test

 test after modification

 production test

Test case	Clause	Required	Result	Remarks
<b>INFORMATIONAL TRANSMITTER PARAMETERS</b>				
Occupied Bandwidth	IC RSS-Gen. 4.6.1	<input checked="" type="checkbox"/>	PASS	
<b>TRANSMITTER PARAMETERS</b>				
20dB Bandwidth	FCC § 15.247(a)(1) IC RSS-210 § A8.1	<input checked="" type="checkbox"/>	PASS	
Frequency hopping channel number	FCC § 15.247(a)(1)(iii) IC RSS-210 § A8.1	<input checked="" type="checkbox"/>	PASS	
Frequency hopping channel spacing	FCC § 15.247(a)(1) IC RSS-210 § A8.1	<input checked="" type="checkbox"/>	PASS	
Time of occupancy (dwell time)	FCC § 15.247(a)(1)(iii) IC RSS-210 § A8.1	<input checked="" type="checkbox"/>	PASS	
Maximum peak conducted output power	FCC § 15.247(b) IC RSS-210 § A8.4	<input checked="" type="checkbox"/>	PASS	
Maximum peak e.i.r.p. output power	FCC § 15.247(b) IC RSS-210 § A8.4	<input checked="" type="checkbox"/>	PASS	
Band-edge Compliance	FCC § 15.247(d) IC RSS-210 § A8.5	<input checked="" type="checkbox"/>	PASS	
Conducted spurious emissions	FCC § 15.247(d) IC RSS-210 § A8.5	<input checked="" type="checkbox"/>	PASS	
Radiated spurious emissions	FCC § 15.247(d) FCC § 15.209 IC RSS-210 § A8.5 IC RSS-Gen § 4.9	<input checked="" type="checkbox"/>	PASS	
<b>RECEIVER PARAMETERS</b>				
Radiated spurious emissions	FCC § 15.109 IC RSS-Gen § 4.10 IC RSS-Gen § 7.2.3	<input checked="" type="checkbox"/>	PASS	IC only
<b>POWER LINE PARAMETERS</b>				
AC power line conducted emissions	FCC § 15.207 IC RSS-Gen. 7.2.2	<input checked="" type="checkbox"/>	PASS	

### 3 Informational Transmitter parameters

#### 3.1 Transmitter Modes for conformance testing

The following transmission modes are elected for compliance testing.

TEST MODE DH5	
Conditions	
Spread Spectrum :	<input checked="" type="checkbox"/> Yes <input type="checkbox"/> No
Spreading Technique :	FHSS
Modulation :	GFSK
Packet Type :	DH5
Data rate :	1Mbps

### 3.2 Occupied Bandwidth

According to RSS-Gen Section 4.6.1 the 99% emission bandwidth occupied by the modulated transmitted signal has to be reported as calculated or measured.

#### 3.2.1 Measurement procedure

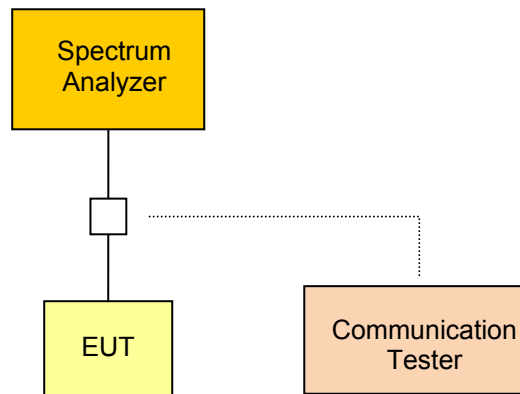

The EUT is connected to a spectrum analyzer and set to transmission mode (using a communication tester if needed) with maximum power under normal test conditions. The span of the analyzer is set wide enough to capture all significant emissions of the modulation spectrum. The resolution bandwidth is set as close as possible to 1% of the selected span without being below 1%. The occupied bandwidth is then measured and evaluated by an internal measurement procedure of the analyzer.

### 3.2.2 Results

Transmitter occupied bandwidth			
Measurement Conditions			
Power occupation :		99%	
Channel [MHz]	Lower edge frequency [MHz]	Upper edge frequency [MHz]	Occupied Bandwidth [MHz]
Test mode DH5			
2402	2401.550	2402.460	0.910
2441	2440.550	2441.460	0.910
2480	2479.530	2480.480	0.950
See attached diagram in Annex			
Verdict			PASS

## 4 Transmitter parameters

### 4.1 20dB Bandwidth

According FCC rules 47 CFR 15.247(a)(1) and RSS-210 Section A8.1 the 20dB Bandwidth determines the necessary carrier spacing used in the frequency hopping system.

#### 4.1.1 Limits

According FCC and IC rules frequency hopping systems shall have hopping channel carrier frequencies separated by a minimum of 25kHz or the 20dB bandwidth of the hopping channel, whichever is greater. Alternatively, frequency hopping systems operating in the 2400–2483.5 MHz band may have hopping channel carrier frequencies that are separated by 25 kHz or two-thirds of the 20 dB bandwidth of the hopping channel, whichever is greater, provided the systems operate with an output power no greater than 125 mW.

20dB bandwidth limits	
Output Power	20dB Bandwidth Limit
$\leq 125\text{mW} / 21\text{dBm}$	1.5 * carrier spacing
125mW – 1W / 21 – 30dBm	1.0 * carrier spacing

#### 4.1.2 Measurement procedure

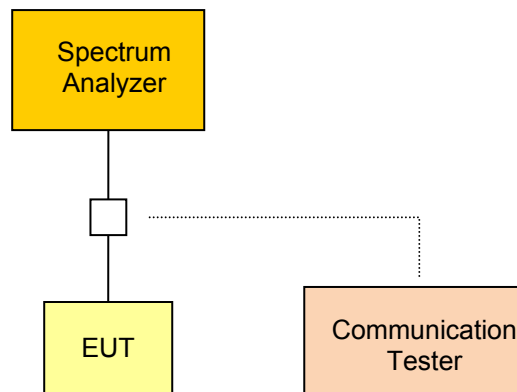

The EUT is connected to a spectrum analyzer and set to transmission mode (using a communication tester if needed) with maximum power under normal test conditions. The resolution bandwidth is set to 1% of the 20dB bandwidth of the emission spectrum ( $VBW \geq RBW$ ). The center frequency is set to the hopping channel center frequency. The span of the analyzer is set to 2 -3 times the 20dB bandwidth. The bandwidth is determined using markers with peak detector and max hold.

According to 47 CFR 15.31 battery power equipment is measured using new batteries and equipment using external power supply is measured with 85%, 100% and 115% of the nominal rated supply voltage.

#### 4.1.3 Results

20dB bandwidth		
Measurement Conditions		
Max. output power :	-6.3dBm	
Carrier spacing :	1MHz	
Channel [MHz]	20dB Bandwidth [MHz]	Bandwidth Limit [MHz]
Test mode DH5		
2402	0.847	≤ 1.5
2441	0.847	≤ 1.5
2480	0.851	≤ 1.5
See attached diagrams in Annex		
Measurement uncertainty		4.22dB
<b>Verdict</b>		<b>PASS</b>



## 4.2 Frequency hopping channel number

According FCC rules 47 CFR 15.247(a)(1)(iii) and RSS-210 Section A8.1 the number of hopping channels used, determines if the system can be certified as a hopping system and also the power level the system can use.

### 4.2.1 Limits

According FCC and IC rules frequency hopping systems shall use a minimum of 15 hopping channels. If the hopping system uses at least 75 hopping channels, the maximum conducted output power can be increased from 0.125W to 1W.

Frequency hopping channel number limits	
Max. conducted output Power	Minimum number of channels
$\leq 125\text{mW} / 21\text{dBm}$	15
125mW – 1W / 21 - 30dBm	75

### 4.2.2 Measurement procedure

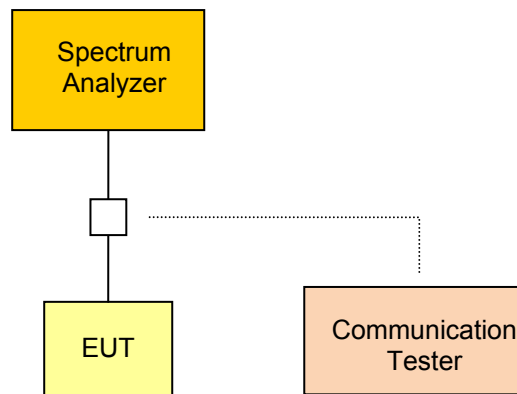

The EUT is connected to a spectrum analyzer and set to transmission mode (using a communication tester if needed) with hopping activated. The resolution bandwidth is set to 1% of the span ( $VBW \geq RBW$ ) and the span is set to 2400 – 2483.5MHz. The power level is measured with peak detector and max hold.

#### 4.2.3 Results

Number of hopping channels	
<b>Measurement Conditions</b>	
<b>Test mode :</b>	DH5
<b>Max. output power :</b>	-6.3dBm
Number of channels	Hopping channel limit
79	≥ 15
<b>See attached diagrams in Annex</b>	
Measurement uncertainty	4.22dB
<b>Verdict</b>	<b>PASS</b>

### 4.3 Frequency hopping channel spacing

According FCC rules 47 CFR 15.247(a)(1) and RSS-210 Section A8.1 the minimum hopping channel frequency spacing is correlated to the 20dB bandwidth of the hopping channel emission and and maximum peak output power.

#### 4.3.1 Limits

According FCC and IC rules frequency hopping systems shall have hopping channel carrier frequencies separated by a minimum of 25kHz or the 20dB bandwidth of the hopping channel, whichever is greater. Alternatively, frequency hopping systems operating in the 2400–2483.5 MHz band may have hopping channel carrier frequencies that are separated by 25 kHz or two-thirds of the 20 dB bandwidth of the hopping channel, whichever is greater, provided the systems operate with an output power no greater than 125 mW.

Frequency hopping channel spacing limits	
Max. conducted output Power	Minimum hopping channel spacing
$\leq 125\text{mW} / 21\text{dBm}$	$\geq 25\text{kHz}$ or $\frac{2}{3}$ of 20dB bandwidth
$125\text{mW} - 1\text{W} / 21 - 30\text{dBm}$	$\geq 25\text{kHz}$ or 20dB bandwidth

#### 4.3.2 Measurement procedure

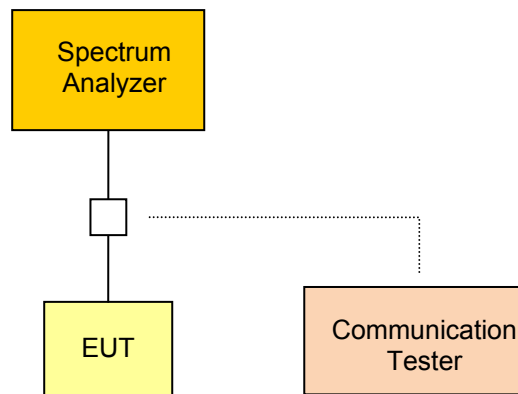

The EUT is connected to a spectrum analyzer and set to transmission mode (using a communication tester if needed) with hopping activated. The resolution bandwidth is set to 1% of the span ( $VBW \geq RBW$ ) and the span is set wide enough to capture two adjacent channels. The power level is measured with peak detector and max hold.

### 4.3.3 Results

Frequency hopping channel spacing	
<b>Measurement Conditions</b>	
<b>Test mode :</b>	DH5
<b>Tested channels :</b>	2441MHz / 2442MHz
<b>Max. output power :</b>	-6.3dBm
Channel spacing [kHz]	Channel spacing limit [kHz]
1.000	$\geq \frac{2}{3} * 851 = 567$
<b>See attached diagrams in Annex</b>	
Measurement uncertainty	4.22dB
<b>Verdict</b>	<b>PASS</b>

#### 4.4 Time of occupancy (Dwell time)

According FCC rules 47 CFR 15.247(a)(1)(iii) and RSS-210 Section A8.1 the average time of occupancy on any channel is limited.

##### 4.4.1 Limits

According FCC and IC rules the average time of occupancy on any channel shall not be greater than 0.4 seconds within a period of 0.4 seconds multiplied by the number of hopping channels employed.

Time of occupancy (dwell time) limits	
Dwell time limit	Channel occupancy period
0.4s	$0.4 * \text{Number of hopping channels}$

##### 4.4.2 Measurement procedure

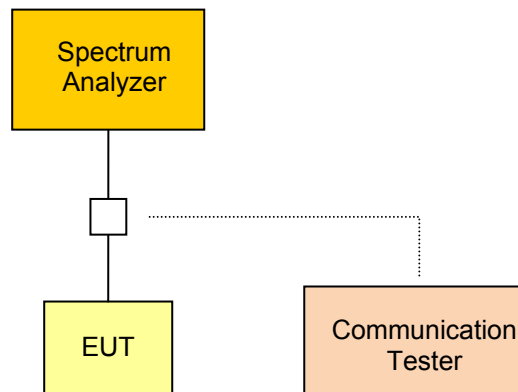

The EUT is connected to a spectrum analyzer and set to transmission mode (using a communication tester if needed) with hopping activated. The resolution bandwidth is set to 1MHz ( $VBW \geq RBW$ ) and the span is set to zero centered on a hopping channel. The sweep time is set large enough to capture the dwell time. The power level is measured with peak detector and max hold.

#### 4.4.3 Results

<b>Time of occupancy (Dwell time)</b>	
<b>Measurement Conditions</b>	
<b>Test mode :</b>	DH5
<b>Tested channel :</b>	2441
<b>Number of hopping channels :</b>	79
<b>Time of occupancy</b>	<b>Channel occupancy periode</b>
64 * 2.907ms = 186ms	31.6s
<b>See attached diagrams in Annex</b>	
Measurement uncertainty	4.22dB
<b>Verdict</b>	<b>PASS</b>

## 4.5 Maximum peak conducted output power

According FCC rules 47 CFR 15.247(b)(1) and RSS-210 Section A8.4 the maximum peak conducted output power is limited and has been verified.

### 4.5.1 Limits

For frequency hopping systems operating in the band 2400-2483.5 MHz employing at least 75 hopping channels, the maximum peak conducted output power shall not exceed 1 W; for all other frequency hopping systems in the band, the maximum peak conducted output power shall not exceed 0.125 W.

Maximum peak conducted output power limits	
Number of Hopping Channels	Conducted Power Limit
≥ 75	1W (30dBm)*
15 - 74	125mW (21dBm)*

\*) The conducted output power limit specified above is based on the use of antennas with directional gains that do not exceed 6 dBi. If transmitting antennas of directional gain greater than 6 dBi are used, the conducted output power from the intentional radiator shall be reduced below the stated values in the table, as appropriate, by the amount in dB that the directional gain of the antenna exceeds 6 dBi.

### 4.5.2 Measurement procedure

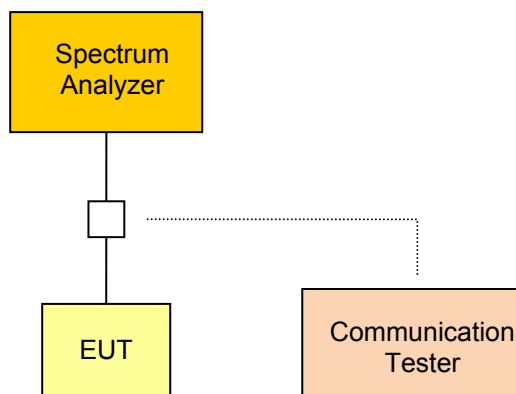

The EUT is connected to a spectrum analyzer and set to transmission mode (using a communication tester if needed) with maximum power under normal test conditions. The resolution bandwidth is set higher than the 20dB Bandwidth of the emission spectrum ( $VBW \geq RBW$ ). The span of the analyzer is set larger than 5 times the resolution bandwidth. The maximum power emitted by the EUT is measured using peak detector and max hold.

According to 47 CFR 15.31 battery power equipment is measured using new batteries and equipment using external power supply is measured with 85%, 100% and 115% of the nominal rated supply voltage.

#### 4.5.3 Results

Maximum peak conducted output power		
Measurement Conditions		
Antenna gain :	0dBi	
Power correction :	0dB	
Number of Hopping channels :	79	
Channel [MHz]	Conducted output power [dBm]	Power Limit [dBm]
Test mode DH5		
2402	-6.3	≤ 30
2441	-6.4	≤ 30
2480	-6.7	≤ 30
See attached diagrams in Annex		
Measurement uncertainty		4.22dB
Verdict		<b>PASS</b>



## 4.6 Maximum e.i.r.p. output power

According FCC rules 47 CFR 15.247(b)(1) and RSS-210 Section A8.4 the maximum peak e.i.r.p. conducted output power is limited and has be verified.

### 4.6.1 Limits

According to the FCC Rules the conducted output power limit specified is based on the use of antennas with directional gains that do not exceed 6 dBi. If transmitting antennas of directional gain greater than 6 dBi are used, the conducted output power from the intentional radiator shall be reduced below the stated values in the table, as appropriate, by the amount in dB that the directional gain of the antenna exceeds 6 dBi. This translates to the following e.i.r.p. power limits.

Maximum e.i.r.p. output power limits	
Number of Hopping Channels	E.I.R.P. Power Limit
≥ 75	4W e.i.r.p. (36dBm e.i.r.p.)
15 - 74	500mW e.i.r.p. (27dBm e.i.r.p.)*

\*) According RSS-210 the e.i.r.p. output power is generally limited to 4W (36dBm) without limit on the number of hopping channels.

### 4.6.2 Measurement procedure

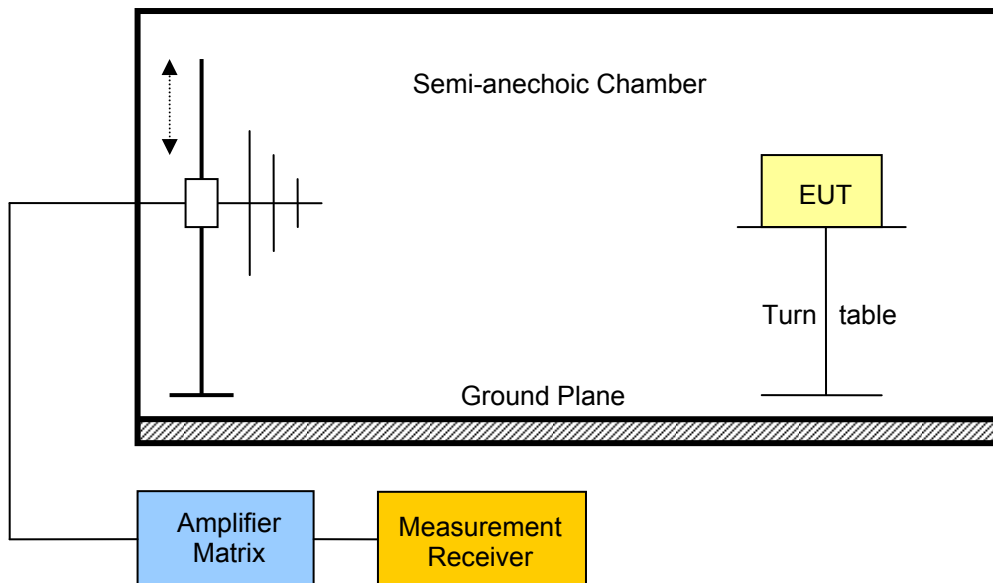

The EUT is placed on a table in a semi-anechoic chamber. The EUT is activated with the transmission modes stated in the test report. The emission level of all emission up to the 10<sup>th</sup> harmonic is scanned. In the frequency range below 1GHz a resolution bandwidth of 100kHz is used and above 1GHz a resolution bandwidth of 1MHz is used. To obtain the peak emission level the EUT is rotated through 360° and the height of the measurement antenna changed. All emission that come to within 20dB of the limit line are recorded.

### Alternate validation procedure

Alternatively the e.i.r.p. power is calculated from the declared antenna gain and the measured maximum peak conducted output power.

Which method has been used is stated in the result table.

#### 4.6.3 Results

Maximum e.i.r.p. output power		
Measurement Conditions		
Validation methode :	<input type="checkbox"/> Measurement <input checked="" type="checkbox"/> Alternate	
Antenna gain :	0dBi	
Channel [MHz]	E.I.R.P. output power [dBm e.i.r.p.]	E.I.R.P. Power Limit [dBm e.i.r.p.]
Test mode DH5		
2402	-6.3	≤ 36
2441	-6.4	≤ 36
2480	-6.7	≤ 36
<b>See attached diagrams in Annex</b>		
Measurement uncertainty		4.22dB
<b>Verdict</b>		<b>PASS</b>

## 4.7 Transmitter band-edge compliance

According FCC rules 47 CFR 15.209, 15.247(d) and RSS-210 Section A8.5 the emission level of out-of-band emissions are limited and has to be validated.

### 4.7.1 Limits

The emission limit of out of band emission in any 100kHz bandwidth outside the frequency band in which the spread spectrum device is operating, the radio frequency power that is produced shall be at least 20 dB below that in the 100 kHz bandwidth within the band that contains the highest level of the desired power, based on either an RF conducted or a radiated measurement, provided the transmitter demonstrates compliance with the peak conducted power limits. If the transmitter complies with the conducted power limits based on the use of RMS averaging over a time interval the attenuation required shall be 30 dB instead of 20 dB. Attenuation below the general limits (see "Transmitter spurious emissions"-measurement) is not required.

Transmitter band-edge emission limits	
TX-Power Detector	Out of band attenuation
Peak	-20dBc/100kHz
RMS	-30dBc/100kHz

### 4.7.2 Measurement procedure

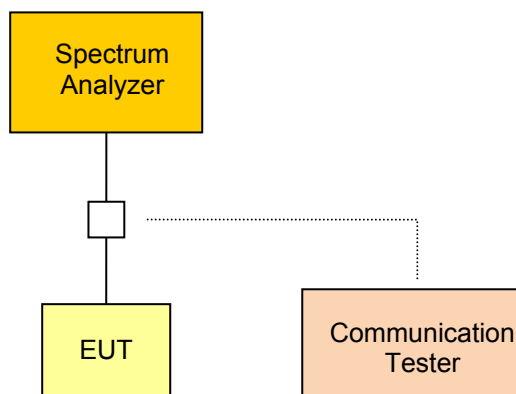

The EUT is connected to a spectrum analyzer and set to transmission mode (using a communication tester if needed) without hopping with maximum power under normal test conditions. The span of the analyzer is set large enough to capture the maximum emission within the emission band as well as any modulation product which fall outside the authorized band of operation. The resolution bandwidth is set to 1% of the span ( $VBW \geq RBW$ ). The

A marker is set on the emission at the bandedge, or on the highest modulation product outside of the band, if this level is greater than that at the bandedge. Using the delta-marker function the highest peak of the in-band emission is measured.

The same measurement procedure is repeated in hopping mode.

#### 4.7.3 Results

<b>Transmitter band-edge emissions</b>		
<b>Measurement Conditions</b>		
<b>Power mode :</b>	Peak	
<b>Mode</b>	<b>Lower edge emission [dBc]</b>	<b>Upper edge emission [dBc]</b>
Test mode DH5		
Hopping	-45.40	-43.40
Single	-42.94	-42.26
<b>See attached diagram in Annex</b>		
<b>Verdict</b>		<b>PASS</b>

## 4.8 Transmitter conducted spurious emissions

According FCC rules 47 CFR 15.247(d) and RSS-210 Section A8.5 unwanted emissions in the spurious domain are power limited and has to be validated.

### 4.8.1 Limits

The emission limit of out of band emission in any 100kHz bandwidth outside the frequency band in which the spread spectrum device is operating, the radio frequency power that is produced shall be at least 20 dB below that in the 100 kHz bandwidth within the band that contains the highest level of the desired power, based on either an RF conducted or a radiated measurement, provided the transmitter demonstrates compliance with the peak conducted power limits. If the transmitter complies with the conducted power limits based on the use of RMS averaging over a time interval the attenuation required shall be 30 dB instead of 20 dB. Attenuation below the general limits (see "Transmitter radiated spurious emissions"-measurement) is not required.

Transmitter conducted spurious emission limits	
TX-Power Detector	Out of band attenuation
Peak	-20dBc/100kHz
RMS	-30dBc/100kHz

### 4.8.2 Measurement procedure

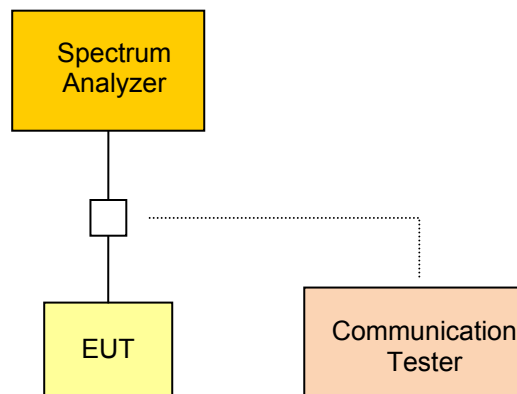

The EUT is connected to a spectrum analyzer and set to transmission mode with maximum power under normal test conditions. The span of the analyzer is set large enough to capture the maximum emission within the emission band as well as any spurious emission outside the authorized band of operation. The resolution bandwidth is set to 100kHz ( $VBW \geq RBW$ ). The emissions are measured using peak detector and max hold.

The measurement is performed over the frequency range of 30MHz up to the tenth harmonic.

#### 4.8.3 Results

Transmitter conducted spurious emissions						
Measurement Conditions						
Modulated :		<input checked="" type="checkbox"/> Yes <input type="checkbox"/> No				
Channel Frequency [MHz]	Emission Frequency [MHz]	Emission Level [dBm]	Peak field Strength [dBm]	Limit [dBm]	Detector	Margin [dB]
Test mode DH5						
2402	4880	-50.12	-9.1	-29.1	peak	-21.02
2441	4880	-47.21	-9.6	-29.6	peak	-19.61
2480	4960	-46.81	-10.5	-30.5	peak	-16.31
See attached diagrams in Annex						
<b>Verdict</b>					<b>PASS</b>	

## 4.9 Transmitter radiated spurious emissions

According FCC rules 47 CFR 15.209, 15.247(d) and RSS-210 Section A8.5 unwanted emissions in the spurious domain are power limited and has to be validated.

### 4.9.1 Limits

The emission limit of out of band emission in any 100kHz bandwidth outside the frequency band in which the spread spectrum device is operating, the radio frequency power that is produced shall be at least 20 dB below that in the 100 kHz bandwidth within the band that contains the highest level of the desired power, based on either an RF conducted or a radiated measurement, provided the transmitter demonstrates compliance with the peak conducted power limits. If the transmitter complies with the conducted power limits based on the use of RMS averaging over a time interval the attenuation required shall be 30 dB instead of 20 dB. Attenuation below the general limits (see "Transmitter spurious emissions"-measurement) is not required.

Transmitter out-of-band emission limits	
TX-Power Detector	Out of band attenuation
Peak	-20dBc/100kHz
RMS	-30dBc/100kHz

In addition, radiated emissions which fall in the restricted bands, as defined in Section 15.205(a), must also comply with the radiated emission limits specified in Section 15.209(a) (see Section 15.205(c)).

Tranmitter restricted band spurious emission limits				
Frequency range [MHz]	Detector	Limit [ $\mu$ V/m]	Calculated Limit 3m [dB $\mu$ V/m]	Measurement Distance [m]
30 – 88	Quasi-Peak	100	40	3
88 – 216	Quasi-Peak	150	43.5	3
216 – 960	Quasi-Peak	200	46	3
960 – 1000	Quasi-Peak	500	54	3
> 1000	Average	500	54	3

When average radiated emission measurements are specified, including average emission measurements below 1000 MHz, there also is a limit on the peak level of the radio frequency emissions. The limit on peak radio frequency emissions is 20 dB above the maximum permitted average emission limit applicable to the equipment under test.

#### 4.9.2 Measurement procedure

The spurious emission measurement is performed on 3m a semi-anechoic test site.

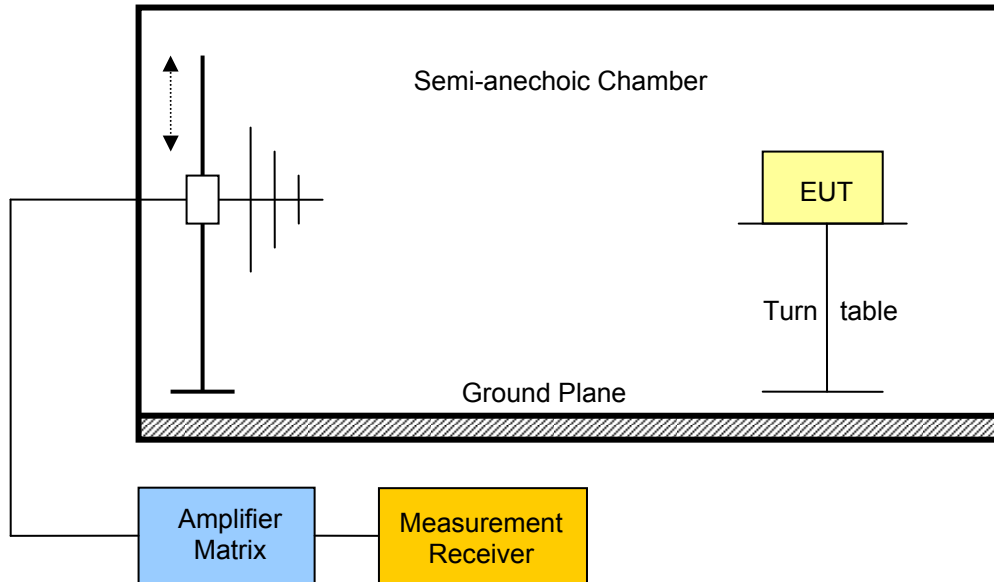

The EUT is placed on a non-metallic table. Any emission is received by the measurement antenna and measured via a measurement receiver connected to the antenna. To obtain the maximum emission the EUT is rotated through 360°.

Due to practical reasons the spurious emission level check is first performed with a peak detector and the quasi-peak and average limits.

If any emission is detected that gets close to the emission limit the detector is changed and the quasi-peak or average detector is used. Which detector is used is determined by the emission frequency. If pulsed transmission is used, averaging over the pulse train is used.

The measurement values are also corrected to obtain the field strength values at the defined measurement distances of the emission limits.

The measurement is performed over the frequency range of 30MHz up to the tenth harmonic.



**4.9.3 Results**

Transmitter radiated spurious emissions – DH5						
Measurement Conditions						
Measurement distance :		3m				
Modulated :		<input checked="" type="checkbox"/> Yes <input type="checkbox"/> No				
Channel Frequency [MHz]	Emission Frequency [MHz]	Polarization	Measured Field Strength [dB $\mu$ V/m]	Limit@3m [dB $\mu$ V/m]	Detector	Margin [dB]
Test mode DH5						
--	--	--	--	--	--	
--	--	--	--	--	--	
See attached diagrams in Annex						
<b>Verdict</b>					<b>PASS</b>	

**Comment:** No significant spurious emissions have been observed.

## 5 Receiver parameters

### 5.1 Receiver spurious emissions

According RSS-Gen Section 4.9 the emission of unintentional radiators have to comply with limits stated in the rules.

#### 5.1.1 Limits

Receiver spurious emission limits @ 3m				
Frequency range [MHz]	Detector	Limit@3m [ $\mu\text{V}/\text{m}$ ]	Calculated Limit @ 3m [ $\text{dB}\mu\text{V}/\text{m}$ ]	Measurement Distance [m]
30 – 88	Quasi-Peak	100	40	3
88 – 216	Quasi-Peak	150	43.5	3
216 – 960	Quasi-Peak	200	46	3
960 – 1000	Quasi-Peak	500	54	3
> 1000	Average	500	54	3

#### 5.1.2 Measurement procedure

The spurious emission measurement is performed on a 3m open area test site.

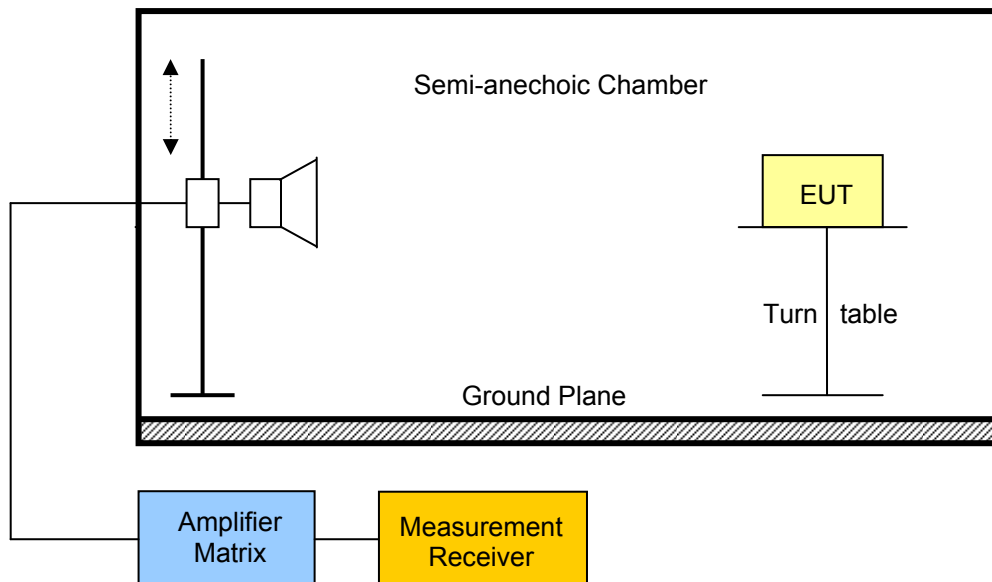

The eut is placed on a non-metallic table. Any emission is received by a loop antenna and measured via a measurement receiver connected to the loop antenna. To obtain the maximum emission the eut is rotated through 360°.

Due to practical reasons the spurious emission level check is first performed with a peak detector and the quasi-peak and average limits.

If any emission is detected that gets close to the emission limit the detector is changed and the quasi-peak or average detector is used. Which detector is used is determined by the emission frequency. If pulsed transmission is used, averaging over the pulse train is used.

The measurement values are also corrected to obtain the field strength values at the defined measurement distances of the emission limits.

The measurement is performed over the frequency range of 30MHz up to the 3rd harmonic.

### 5.1.3 Results

Receiver spurious Emissions						
Measurement Conditions						
Measurement distance :			3m			
Channel Frequency [MHz]	Emission Frequency [kHz]	Polarization	Measured Field Strength [ $\mu\text{V/m}$ ]	Limit@3m [ $\mu\text{V/m}$ ]	Detector	Margin [dB]
RX	194,549	vertical	47,59	150	Peak	-102,41
	190,461	horizontal	46,83	150	Peak	-103,17
	809,218	vertical	25,29	200	Peak	-174,71
	897,395	horizontal	18,90	200	Peak	-181,10
	3934,000	vertical	144,21	500	Peak	-355,79
	2954,000	horizontal	145,38	500	Peak	-354,62
	7848,000	vertical	312,25	500	Peak	-187,75
	7976,000	horizontal	329,99	500	Peak	-170,01
See attached diagrams in Annex						
Verdict					PASS	

\* **Note** : If needed the measured field strength values are corrected to reflect the field strength values at the measurement distance stated in the table. Correction acc.  $20 \cdot \log_{10}(\text{measurement distance}/\text{limit distance})$ .

## 6 Power Line parameters

### 6.1 AC power line conducted emissions

According FCC rules 47 CFR 15.207 and RSS-Gen Section 7.2.2 for any intentional radiator that is designed to be connected to the public utility (AC) power line, the radio frequency voltage that is conducted back onto the AC power line on any frequency or frequencies within the band 150 kHz to 30 MHz shall not exceed the limits given below.

#### 6.1.1 Limits

AC power line emission limits		
Frequency [MHz]	Conducted Limit [dB $\mu$ V]	
	Quasi-Peak	Average
0.15 – 0.5	66 to 56	56 to 46
0.5 - 5	56	46
5 - 30	60	50

#### 6.1.2 Measurement procedure

The ac power line emissions are measured using a 50 $\mu$ H / 50 $\Omega$  line impedance stabilization network (LINS). The radio frequency voltage between each power line and ground at the power terminal is measured.

#### 6.1.3 Results

AC power line emissions	
Conducted emission level	
See attached Diagram	
<b>Verdict</b>	<b>PASS</b>

## Annex B Transmitter occupied bandwidth

### RSS Gen Occupied Bandwidth

EUT	DECT 6.0 Handset
Model	6040 / mode: Bluetooth
Approval Holder	Polycom Denmark ApS / Ord.: G0M21006-3316
Temperature / Voltage	23°C / Vnom
Test Site / Operator	Eurofins Product Service GmbH / Mr. Treffke
Test Specification	4.4.1 Occupied Bandwidth
Comment 1	Channel.: 0 / 2402 MHz
Comment 2	A spectrum analyzer with an integrated 99% power bandwidth function is used

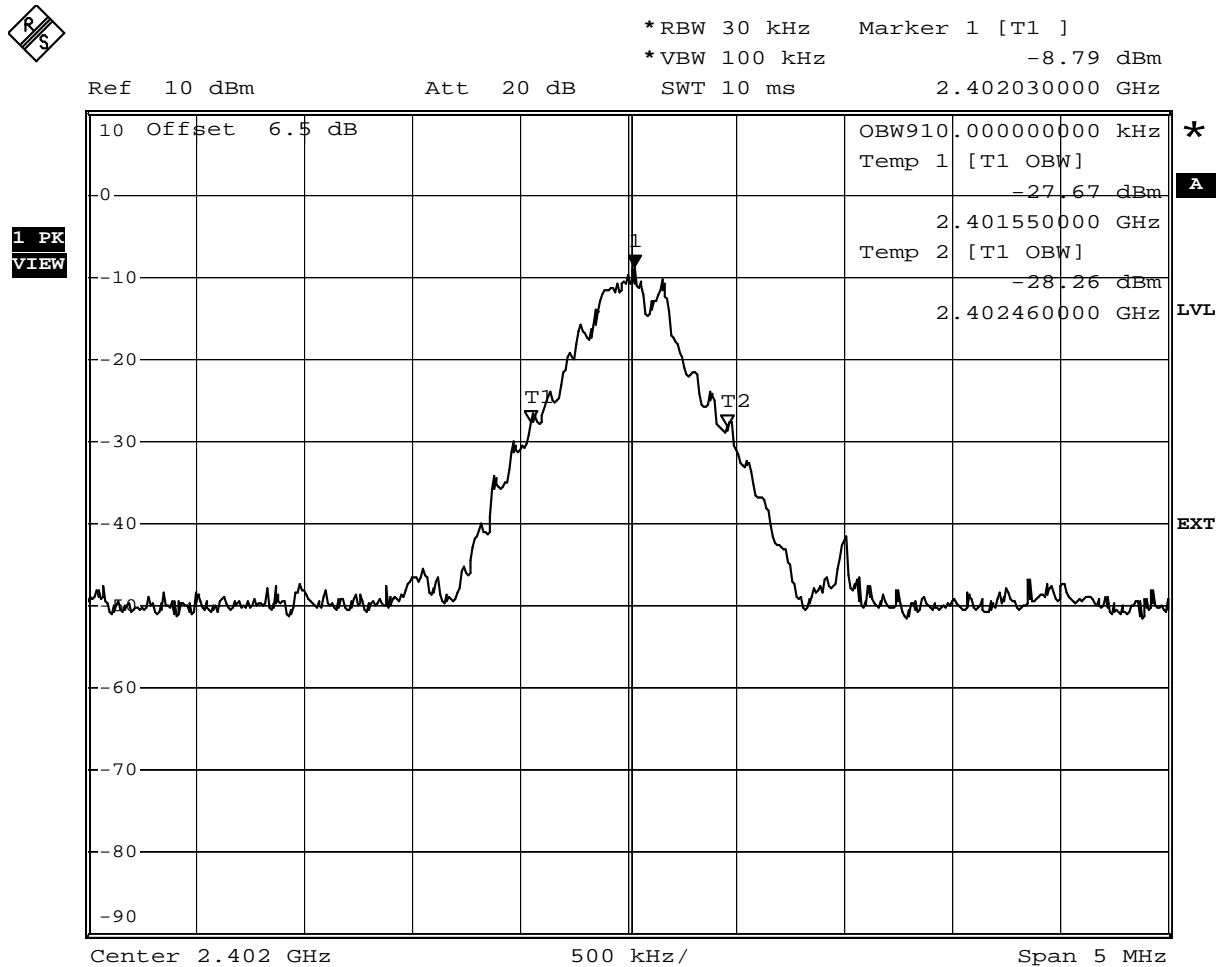

Comment: Occupied bandwidth: 910 KHz  
 Date: 20.SEP.2010 13:19:04

---

Test Report No.: G0M21006-3316-P-15

---

Eurofins Product Service GmbH  
 Storkower Str. 38c, D-15526 Reichenwalde, Germany

**RSS Gen  
Occupied Bandwidth**

EUT	DECT 6.0 Handset
Model	6040 / mode: Bluetooth
Approval Holder	Polycom Denmark ApS / Ord.: G0M21006-3316
Temperature / Voltage	23°C / Vnom
Test Site / Operator	Eurofins Product Service GmbH / Mr. Treffke
Test Specification	4.4.1 Occupied Bandwidth
Comment 1	Channel.: 39 / 2441 MHz
Comment 2	A spectrum analyzer with an integrated 99% power bandwidth function is used

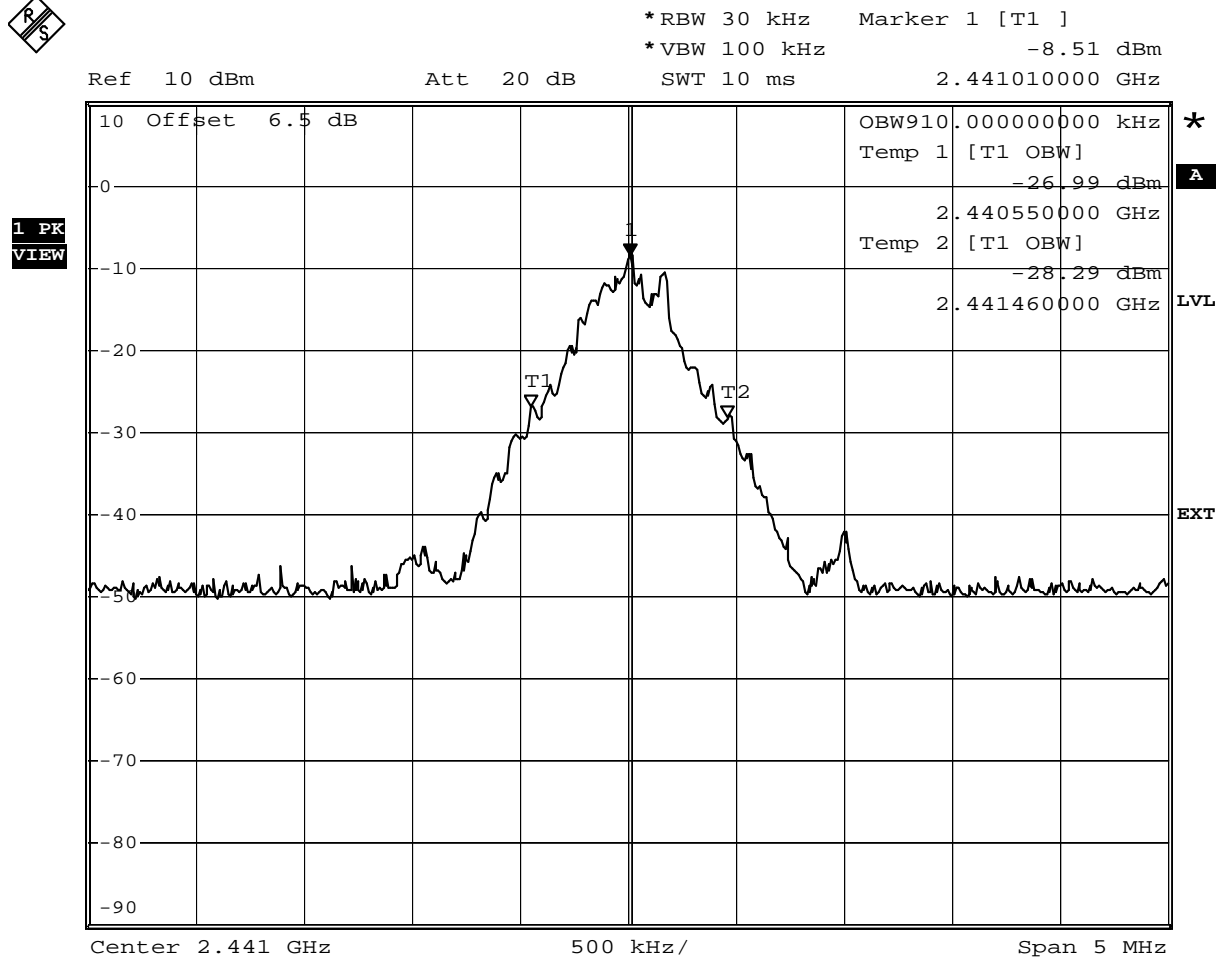

Comment: Occupied bandwidth: 910 KHz  
Date: 20.SEP.2010 13:22:59

**RSS Gen  
Occupied Bandwidth**

EUT	DECT 6.0 Handset
Model	6040 / mode: Bluetooth
Approval Holder	Polycom Denmark ApS / Ord.: G0M21006-3316
Temperature / Voltage	23°C / Vnom
Test Site / Operator	Eurofins Product Service GmbH / Mr. Treffke
Test Specification	4.4.1 Occupied Bandwidth
Comment 1	Channel.: 78 / 2480 MHz
Comment 2	A spectrum analyzer with an integrated 99% power bandwidth function is used

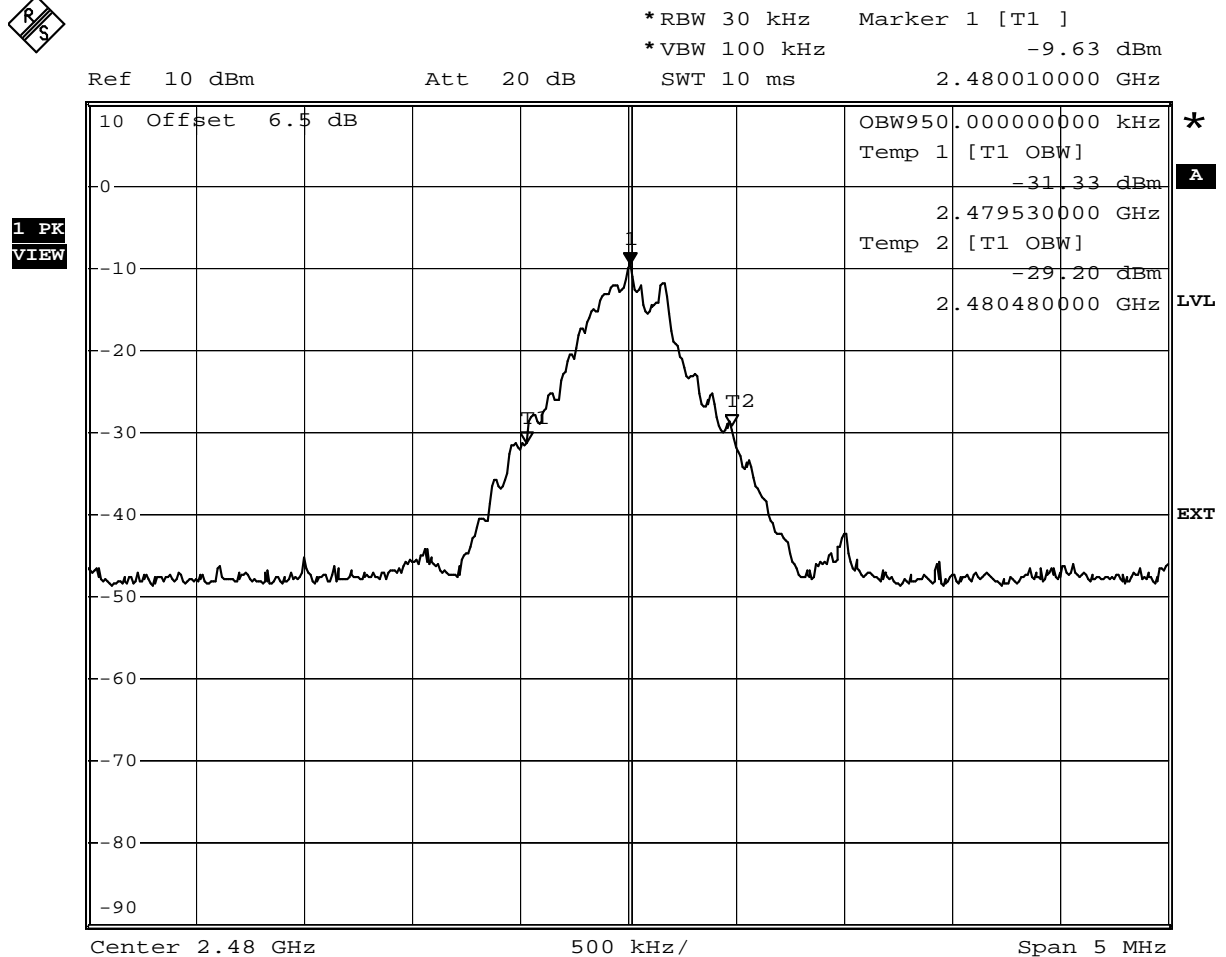

Comment: Occupied bandwidth: 950 KHz  
Date: 20.SEP.2010 13:29:57

## Annex C Transmitter 20dB bandwidth

FCC part 15.247  
20 dB bandwidth

EUT	DECT 6.0 Handset
Model	6040 / mode: Bluetooth
Approval Holder	Polycom Denmark ApS / Ord.: G0M21006-3316
Temperature / Voltage	23°C / Vnom
Test Site / Operator	Eurofins Product Service GmbH / Mr. Treffke
Test Specification	FCC part 15 section 247(a)
Comment 1	20 dB bandwidth
Comment 2	Channel.: 0 / 2402 MHz / GFSK
Comment 3	

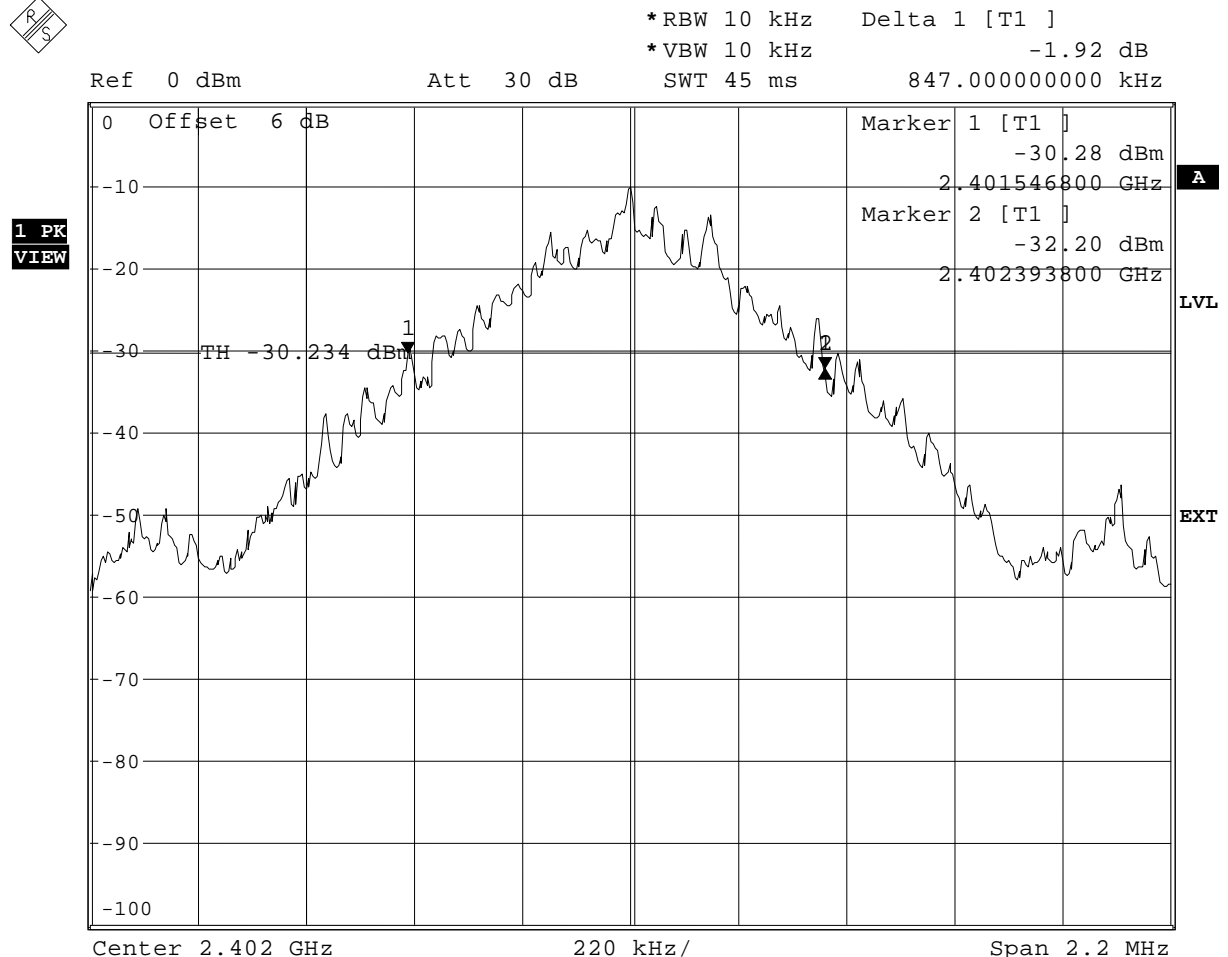

Comment: 20 dB bandwidth: 847 KHz  
Date: 20.SEP.2010 10:00:06



**FCC part 15.247**  
**20 dB bandwidth**

EUT	DECT 6.0 Handset
Model	6040 / mode: Bluetooth
Approval Holder	Polycom Denmark ApS / Ord.: G0M21006-3316
Temperature / Voltage	23°C / Vnom
Test Site / Operator	Eurofins Product Service GmbH / Mr. Treffke
Test Specification	FCC part 15 section 247(a)
Comment 1	20 dB bandwidth
Comment 2	Channel.: 39 / 2441 MHz
Comment 3	

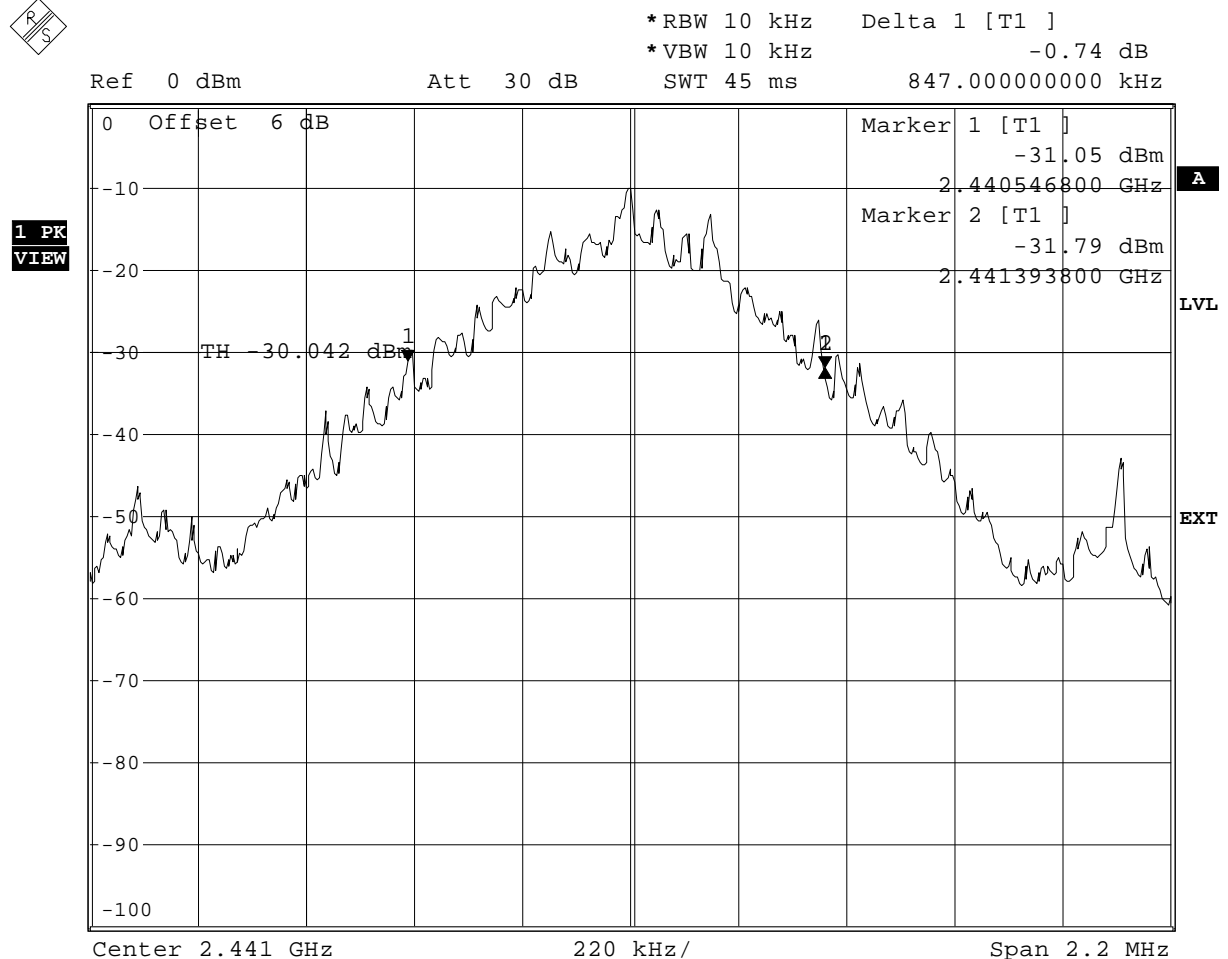

Comment: 20 dB bandwidth: 847 KHz  
 Date: 20. SEP. 2010 10:02:53

**FCC part 15.247  
20 dB bandwidth**

EUT	DECT 6.0 Handset
Model	6040 / mode: Bluetooth
Approval Holder	Polycom Denmark ApS / Ord.: G0M21006-3316
Temperature / Voltage	23°C / Vnom
Test Site / Operator	Eurofins Product Service GmbH / Mr. Treffke
Test Specification	FCC part 15 section 247(a)
Comment 1	20 dB bandwidth
Comment 2	Channel.: 78 / 2480 MHz
Comment 3	

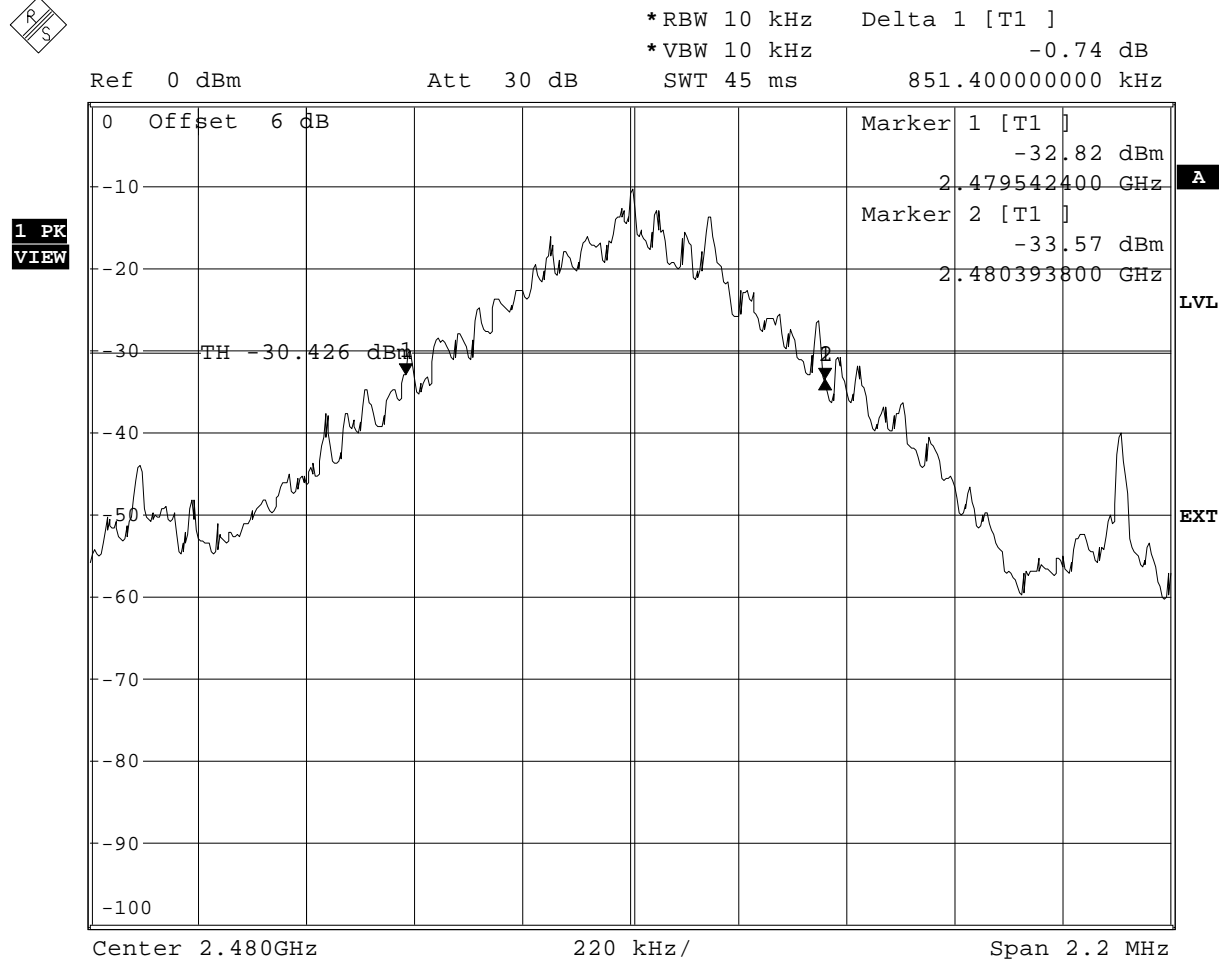

Comment: 20 dB bandwidth: 851.4 KHz  
Date: 20.SEP.2010 10:04:29

## Annex D Hopping channels

### FCC part 15.247

#### Number of hopping frequencies

EUT	DECT 6.0 Handset
Model	6040 / mode: Bluetooth
Approval Holder	Polycom Denmark ApS / Ord.: G0M21006-3316
Temperature / Voltage	23°C / Vnom
Test Site / Operator	Eurofins Product Service GmbH / Mr. Treffke
Test Specification	FCC part 15 section 247(a)
Comment 1	Number of hopping frequencies
Comment 2	Channel.: 0-13
Comment 3	



\*RBW 300 kHz

\*VBW 300 kHz

Ref 10 dBm

Att 40 dB

SWT 2.5 ms

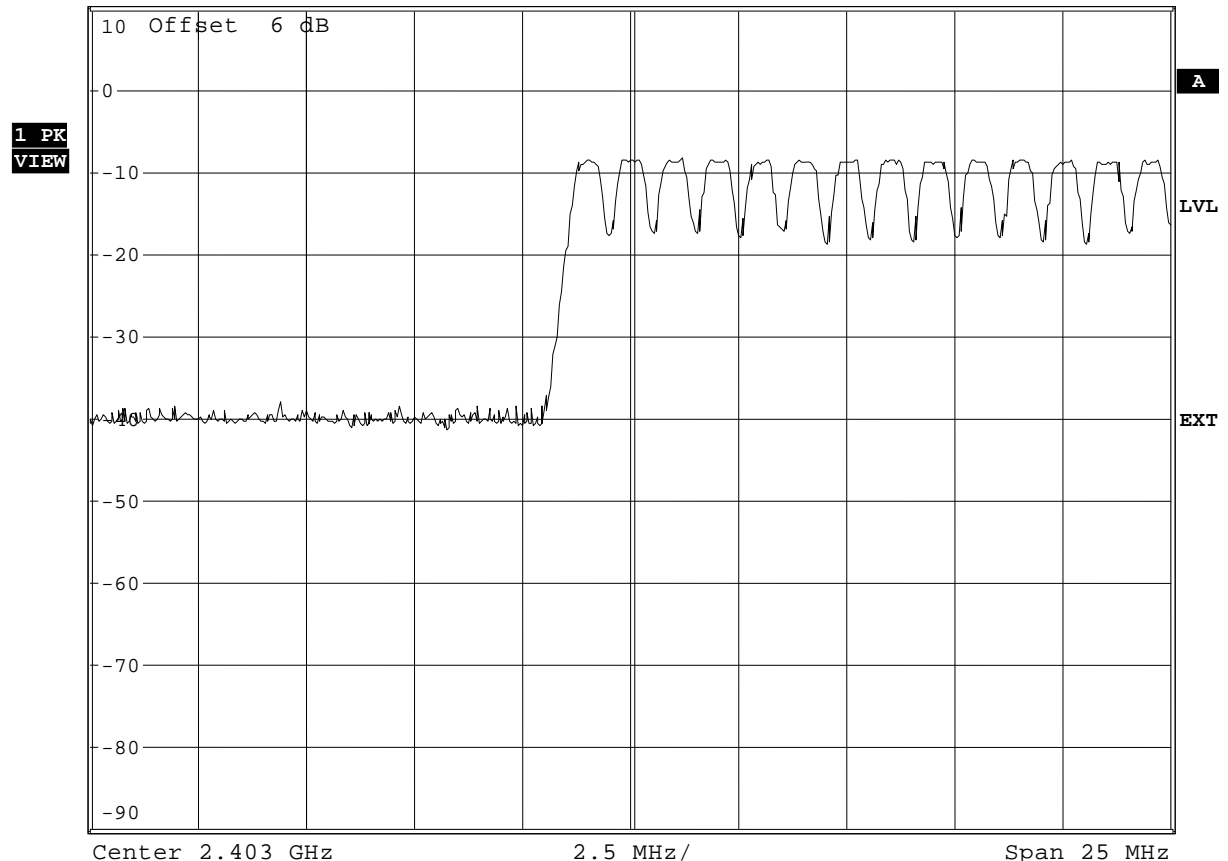

Comment: Number of hopping frequencies

Date: 20.SEP.2010 11:08:43

**FCC part 15.247**  
**Number of hopping frequencies**

EUT	DECT 6.0 Handset
Model	6040 / mode: Bluetooth
Approval Holder	Polycom Denmark ApS / Ord.: G0M21006-3316
Temperature / Voltage	23°C / Vnom
Test Site / Operator	Eurofins Product Service GmbH / Mr. Treffke
Test Specification	FCC part 15 section 247(a)
Comment 1	Number of hopping frequencies
Comment 2	Channel.: 14-38
Comment 3	

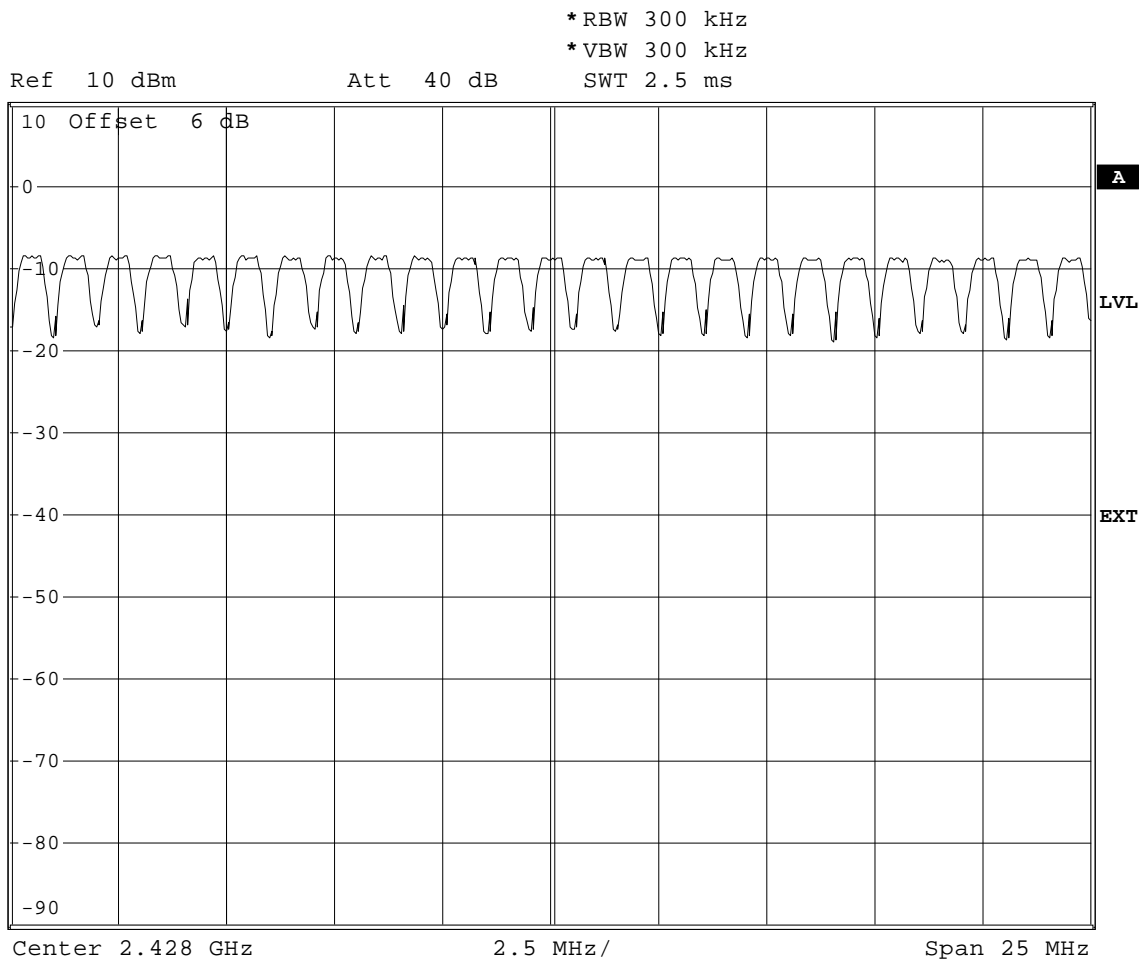

Comment: Number of hopping frequencies  
 Date: 20.SEP.2010 11:13:25

**FCC part 15.247**  
**Number of hopping frequencies**

EUT	DECT 6.0 Handset
Model	6040 / mode: Bluetooth
Approval Holder	Polycom Denmark ApS / Ord.: G0M21006-3316
Temperature / Voltage	23°C / Vnom
Test Site / Operator	Eurofins Product Service GmbH / Mr. Treffke
Test Specification	FCC part 15 section 247(a)
Comment 1	Number of hopping frequencies
Comment 2	Channel.:39-63
Comment 3	



\*RBW 300 kHz  
 \*VBW 300 kHz

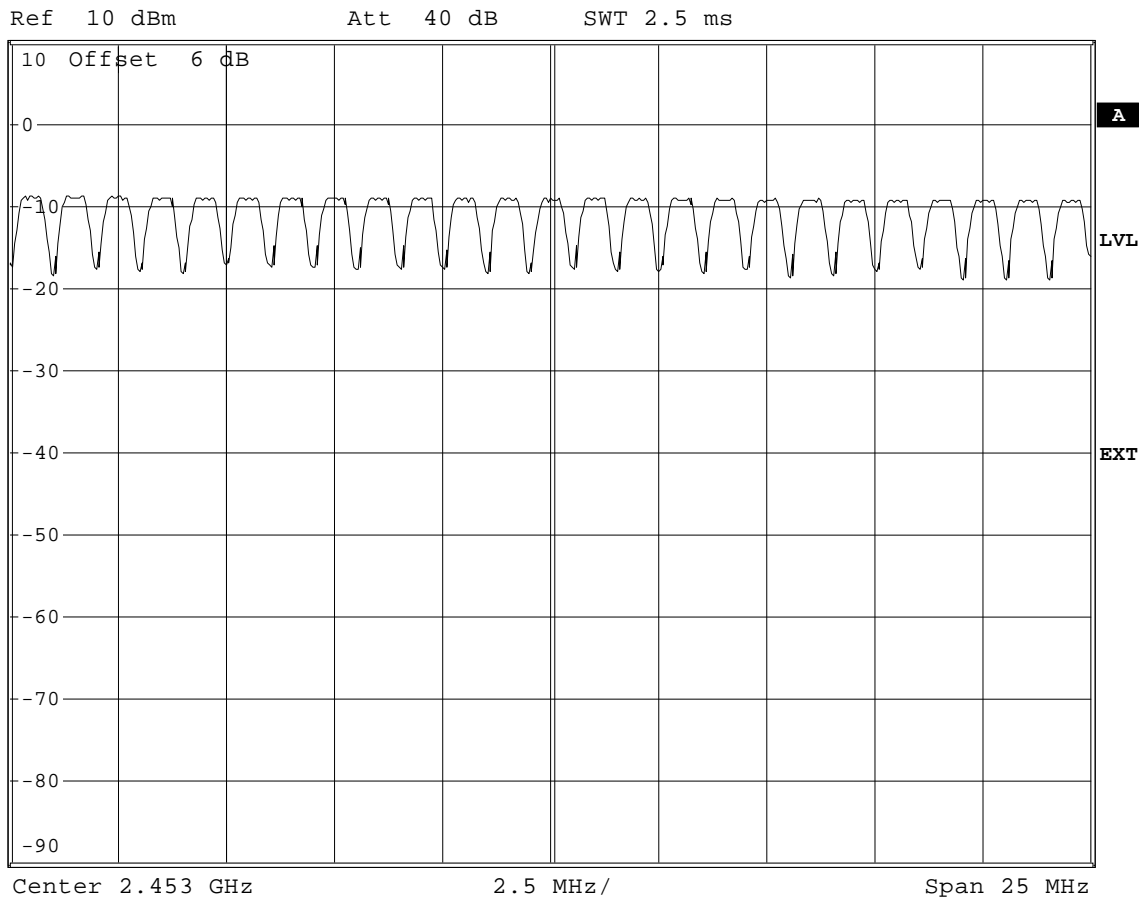

Comment: Number of hopping frequencies  
 Date: 20.SEP.2010 11:56:32

**FCC part 15.247**  
**Number of hopping frequencies**

EUT	DECT 6.0 Handset
Model	6040 / mode: Bluetooth
Approval Holder	Polycom Denmark ApS / Ord.: G0M21006-3316
Temperature / Voltage	23°C / Vnom
Test Site / Operator	Eurofins Product Service GmbH / Mr. Treffke
Test Specification	FCC part 15 section 247(a)
Comment 1	Number of hopping frequencies
Comment 2	Channel.: 64-78
Comment 3	



\*RBW 300 kHz  
 \*VBW 300 kHz

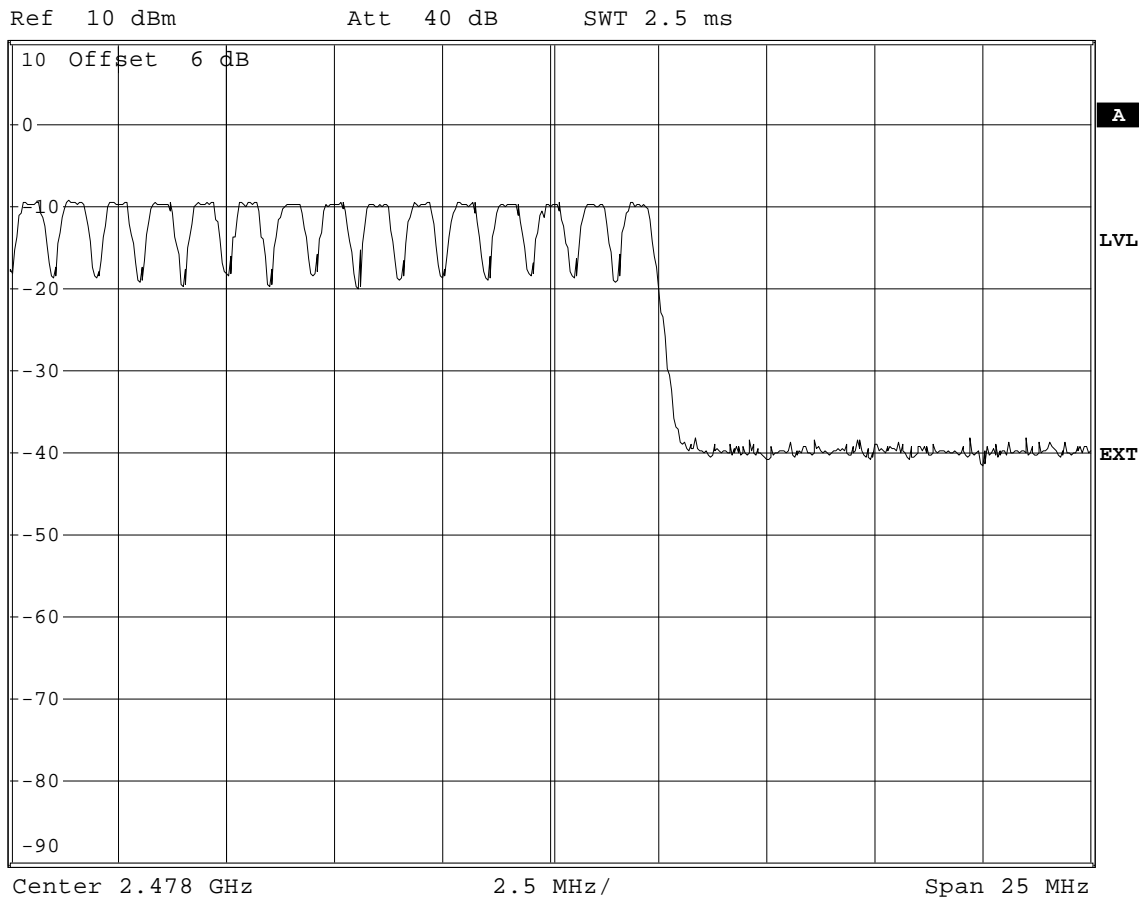

Comment: Number of hopping frequencies  
 Date: 20.SEP.2010 11:58:03

## Annex E Hopping channel separation

### FCC part 15.247

#### Carrier frequency separation

EUT	DECT 6.0 Handset
Model	6040 / mode: Bluetooth
Approval Holder	Polycom Denmark ApS / Ord.: G0M21006-3316
Temperature / Voltage	23°C / Vnom
Test Site / Operator	Eurofins Product Service GmbH / Mr. Treffke
Test Specification	FCC part 15 section 247(a)(1)
Comment 1	Carrier frequency separation
Comment 2	Channel.: 39/40 / 2441/2442 MHz
Comment 3	Hopping mode

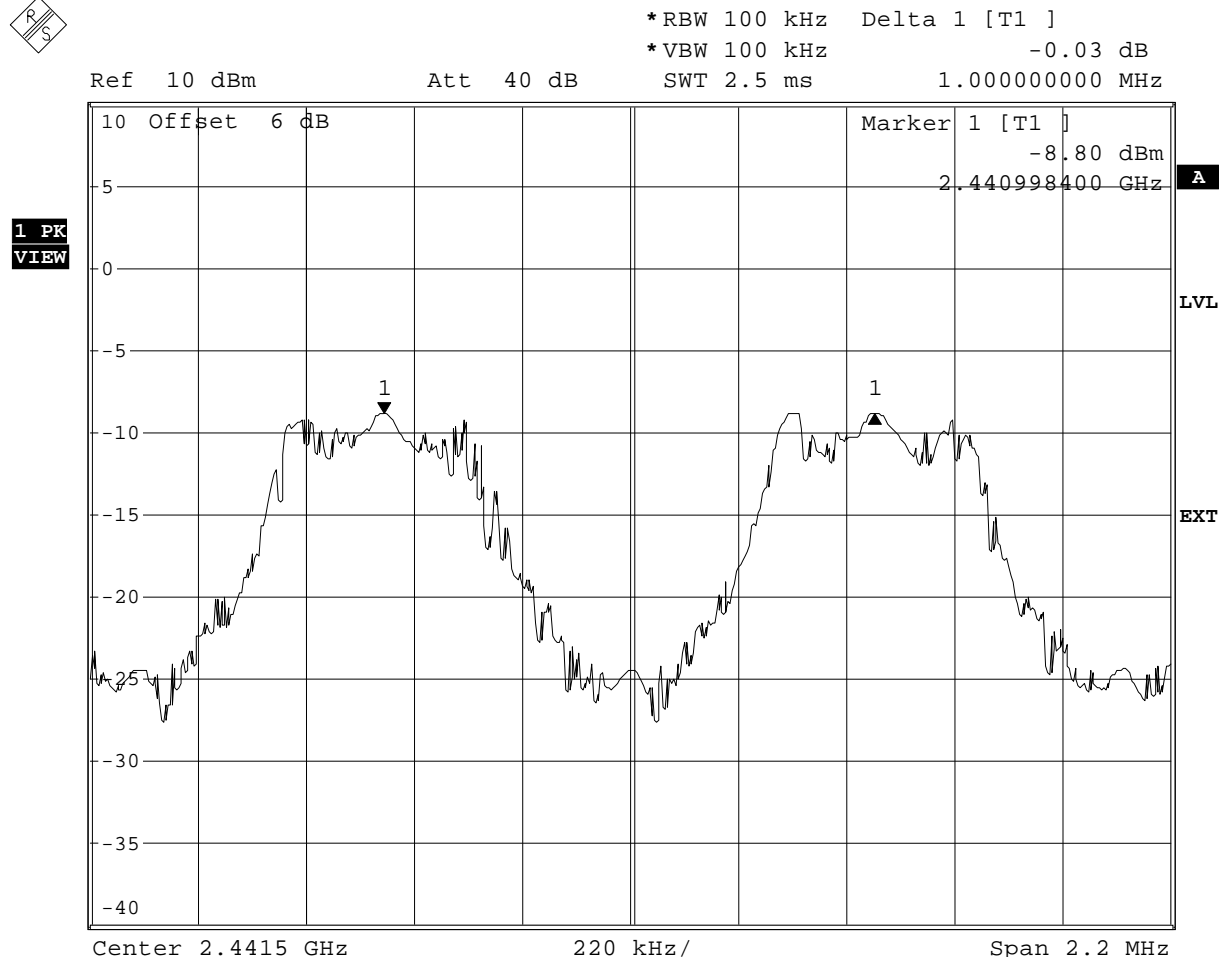

Comment: Limit: > two-thirds of the 20 dB bandwidth ; Result: Pass

Date: 20.SEP.2010 11:06:15

# Annex F Time of occupancy

## FCC part 15.247

### Time of occupancy (dwell time)

EUT	DECT 6.0 Handset
Model	6040 / mode: Bluetooth
Approval Holder	Polycom Denmark ApS / Ord.: G0M21006-3316
Temperature / Voltage	23°C / Vnom
Test Site / Operator	Eurofins Product Service GmbH / Mr. Treffke
Test Specification	FCC part 15 section 247(a)
Comment 1	Time of occupancy
Comment 2	Channel.: 39 / 2441 MHz (Hopping mode)
Comment 3	63 events * 2.907 ms result: 186 ms

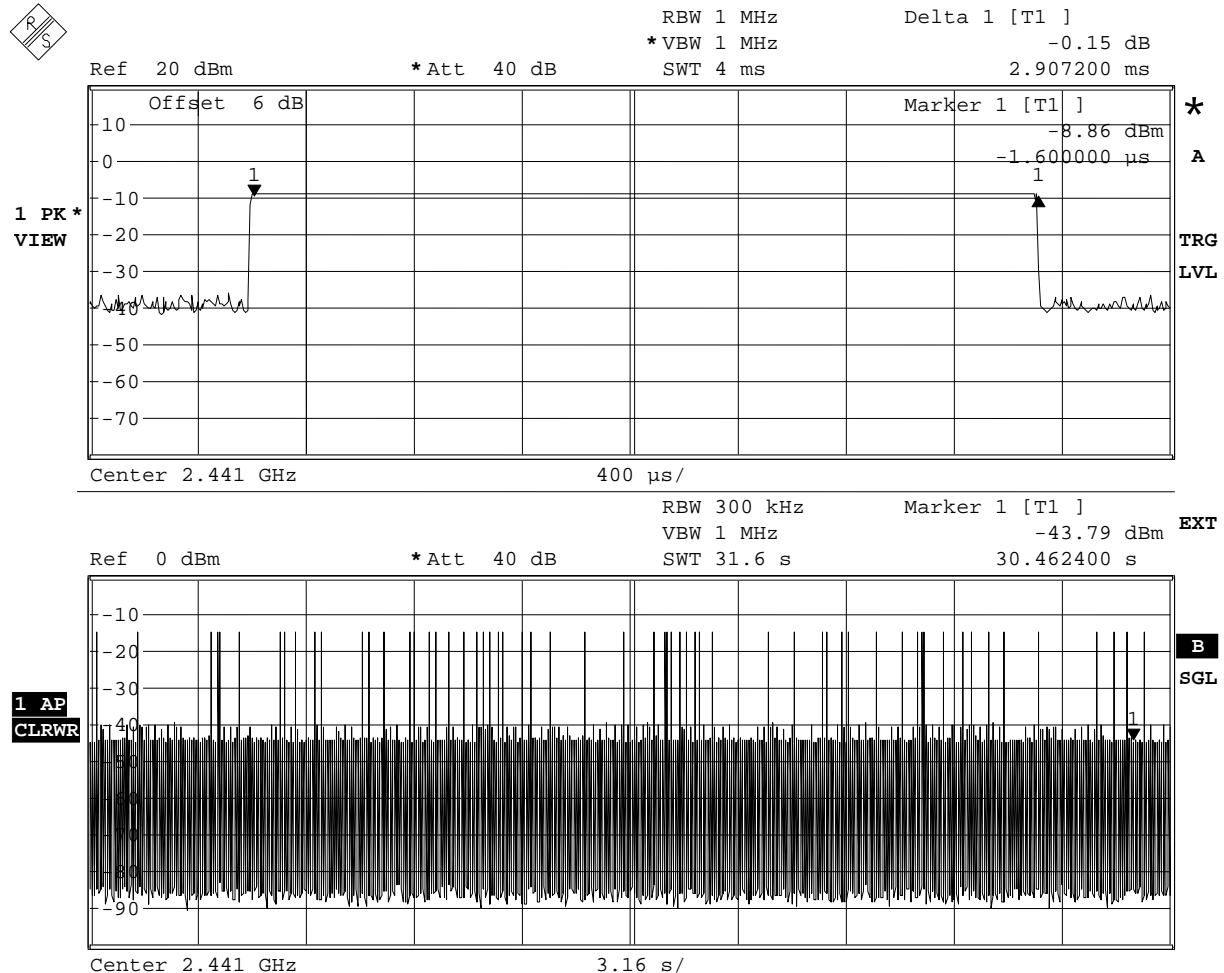

Comment: Burst length=2.9072 ms  
 Date: 20.SEP.2010 12:53:41



**FCC part 15.247  
Duty cycle**

EUT	DECT 6.0 Handset
Model	6040 / mode: Bluetooth
Approval Holder	Polycom Denmark ApS / Ord.: G0M21006-3316
Temperature / Voltage	23°C / Vnom
Test Site / Operator	Eurofins Product Service GmbH / Mr. Treffke
Test Specification	FCC part 15 section 247(b)
Comment 1	Duty cycle
Comment 2	Channel.: 39 / 2441 MHz
Comment 3	

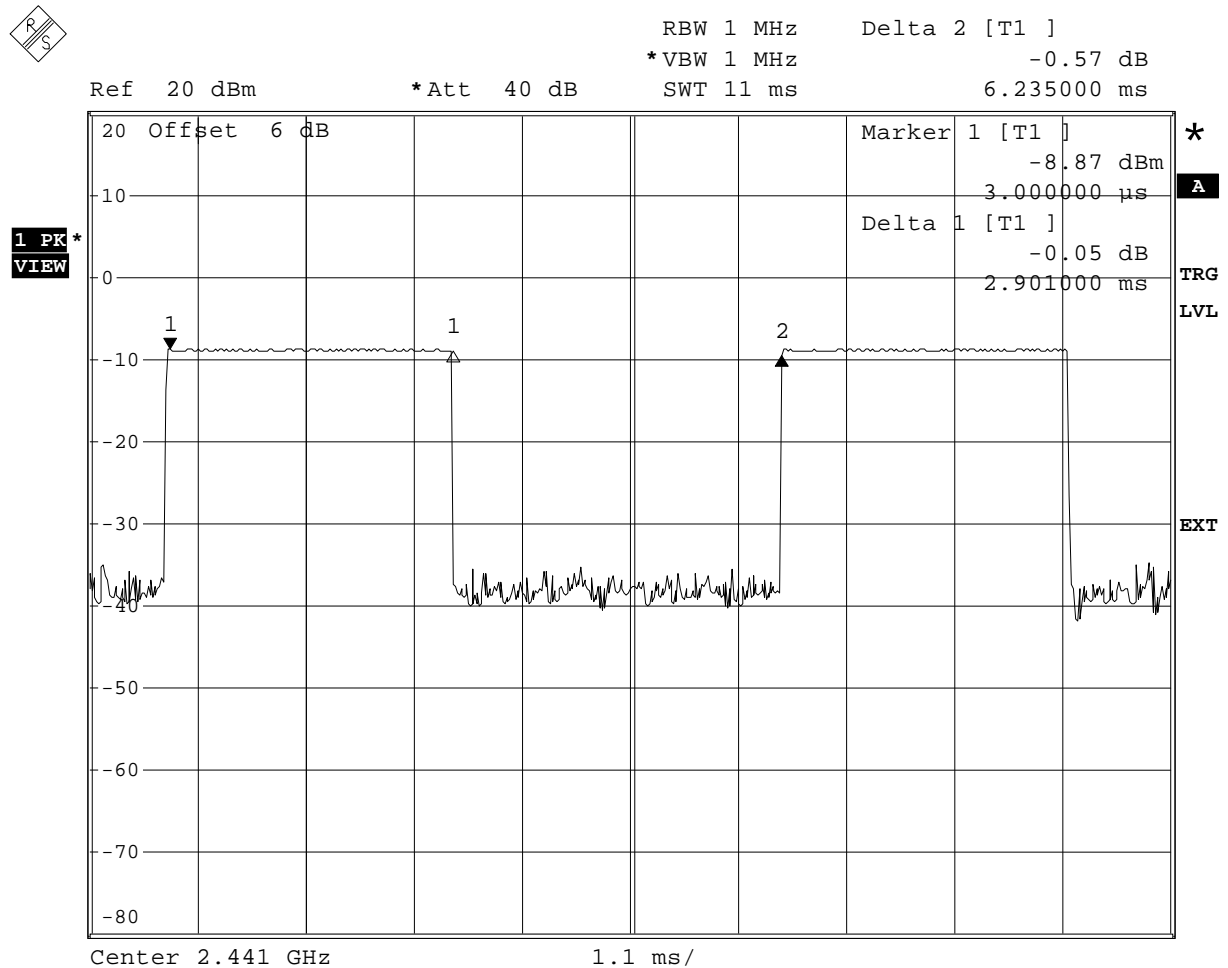

Comment: Duty cycle=0.47  
Date: 20.SEP.2010 12:37:17

## Annex G AC Powerline Conducted Emissions

### EMI voltage test in the ac-mains according to FCC Part 15b

Order number: G0M21006-3316

Manufacturer:	Polycom Inc
EUT Name:	DECT telephone handset
Model:	60xx and 70xx
Test Site:	Eurofins Product Service GmbH
Operator:	Mr. Marquardt
Test Conditions:	Tnom: 23°C, Unom: 120 VAC
LISN:	ESH2-Z5 L
Mode:	charging, DECT link (worst case)
Test Date:	26.08.2010
Note:	70xx + 7040

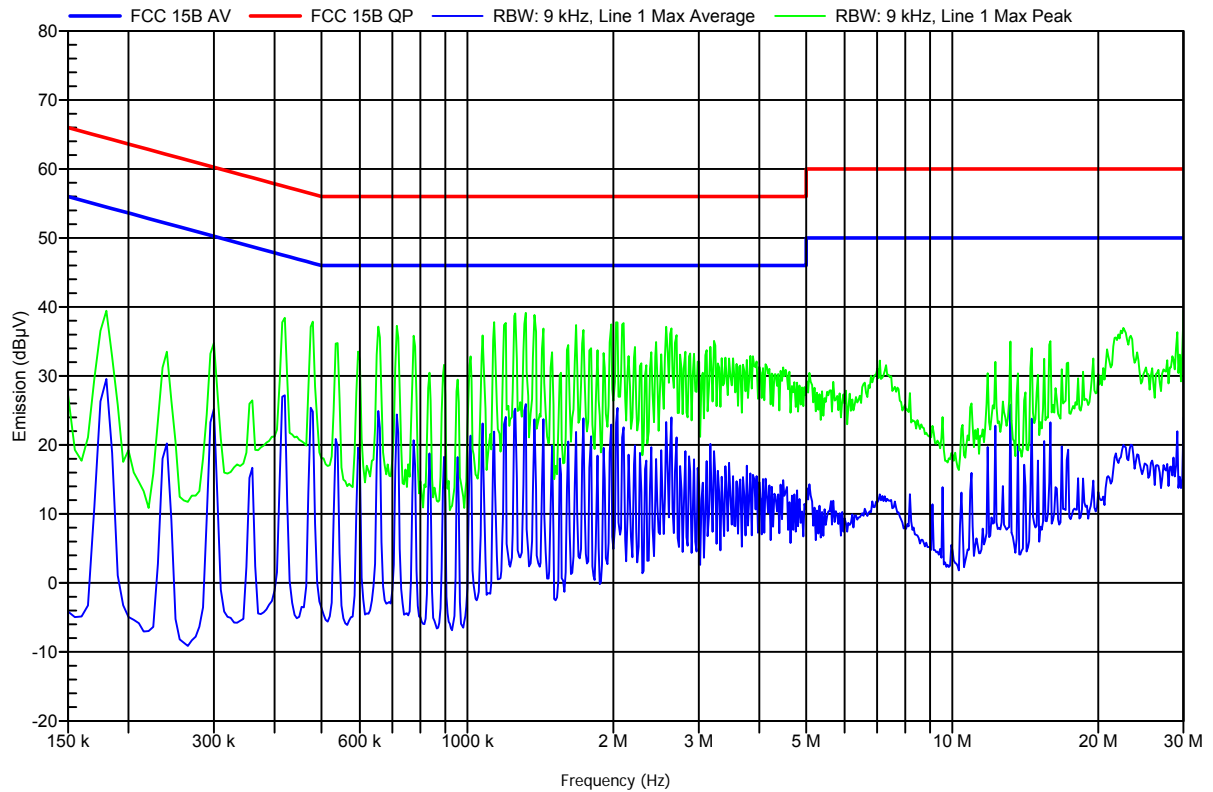

**EMI voltage test in the ac-mains according to FCC Part 15b**

Order number: G0M21006-3316

Manufacturer:	Polycom Inc
EUT Name:	DECT telephone handset
Model:	60xx and 70xx
Test Site:	Eurofins Product Service GmbH
Operator:	Mr. Marquardt
Test Conditions:	Tnom: 23°C, Unom: 120 VAC
LISN:	ESH2-Z5 N
Mode:	charging, DECT link (worst case)
Test Date:	26.08.2010
Note:	70xx + 7040

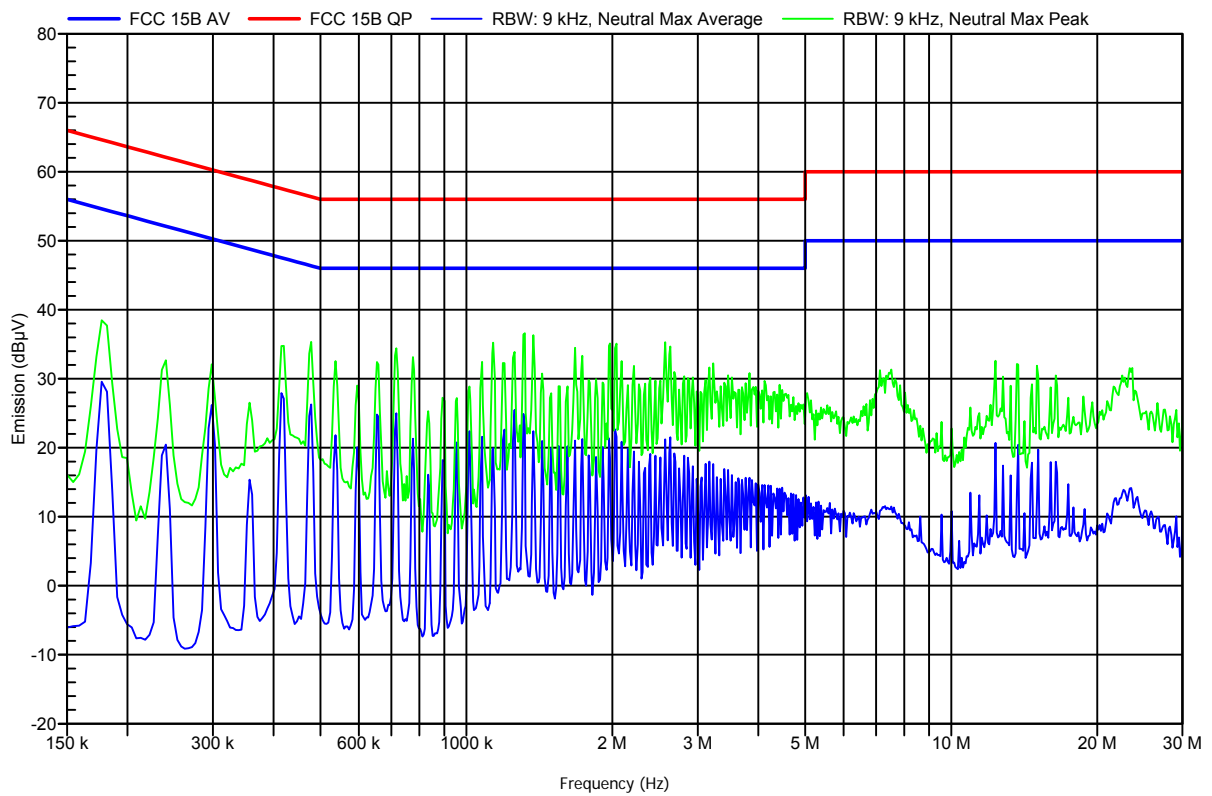

**EMI voltage test in the ac-mains according to FCC Part 15b**

Order number: G0M21006-3316

Manufacturer:	Polycom Inc
EUT Name:	DECT telephone handset
Model:	60xx and 70xx
Test Site:	Eurofins Product Service GmbH
Operator:	Mr. Marquardt
Test Conditions:	Tnom: 23°C, Unom: 120 VAC
LISN:	ESH2-Z5 L
Mode:	charging, DECT link (worst case)
Test Date:	26.08.2010
Note:	60xx + 6040

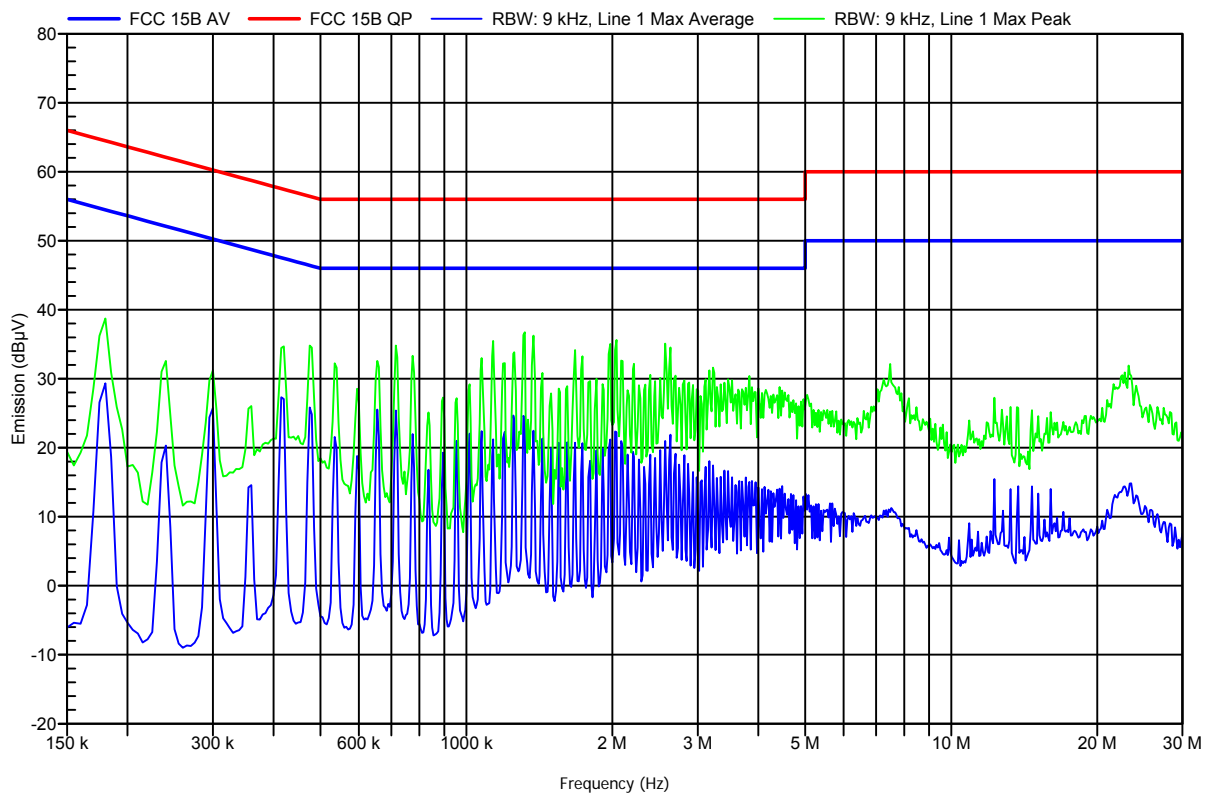

**EMI voltage test in the ac-mains according to FCC Part 15b**

Order number: G0M21006-3316

Manufacturer:	Polycom Inc
EUT Name:	DECT telephone handset
Model:	60xx and 70xx
Test Site:	Eurofins Product Service GmbH
Operator:	Mr. Marquardt
Test Conditions:	Tnom: 23°C, Unom: 120 VAC
LISN:	ESH2-Z5 N
Mode:	charging, DECT link (worst case)
Test Date:	26.08.2010
Note:	60xx + 6040

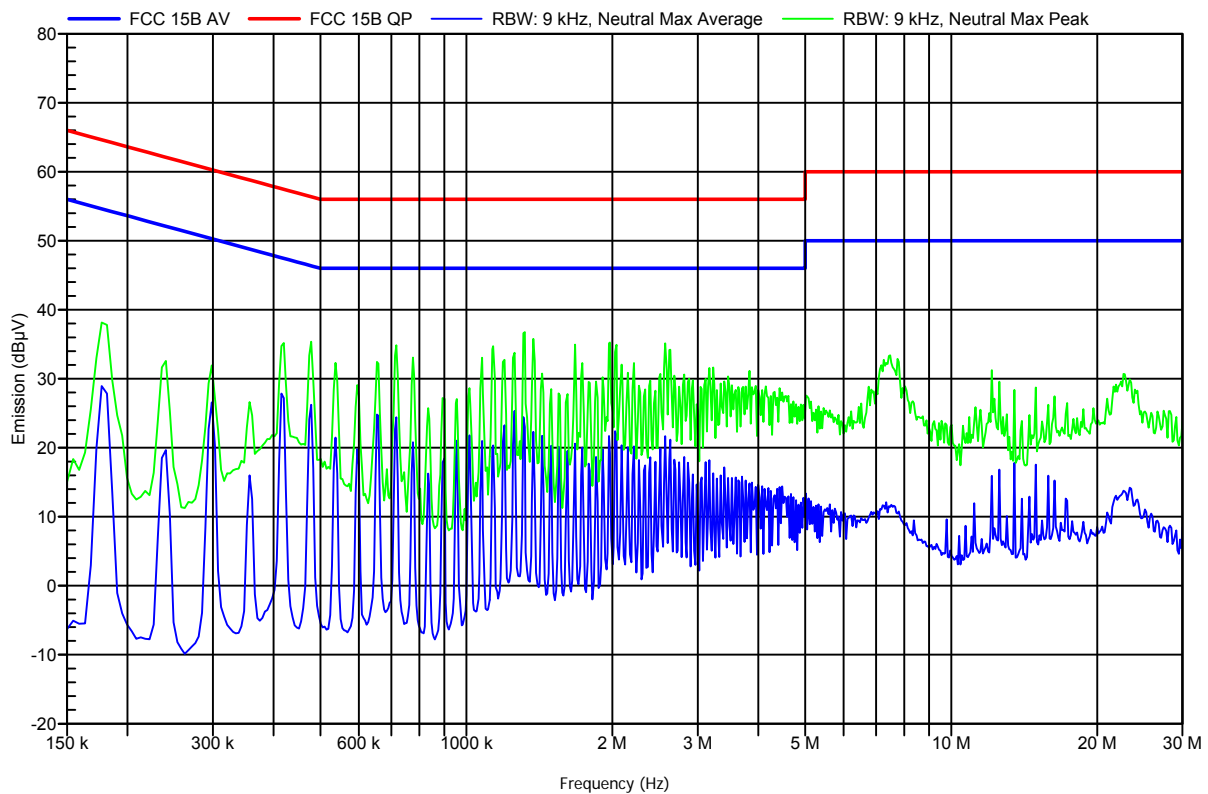

**EMI voltage test in the ac-mains according to FCC Part 15b**

Order number: G0M21006-3316

Manufacturer: Polycom Inc  
 EUT Name: DECT telephone handset  
 Model: 60xx and 70xx  
 Test Site: Eurofins Product Service GmbH  
 Operator: Mr. Marquardt  
 Test Conditions: Tnom: 23°C, Unom: 120 VAC  
 LISN: ESH2-Z5 L  
 Mode: charging, DECT link (worst case)  
 Test Date: 26.08.2010  
 Note: 70xx USB VER. + 7040

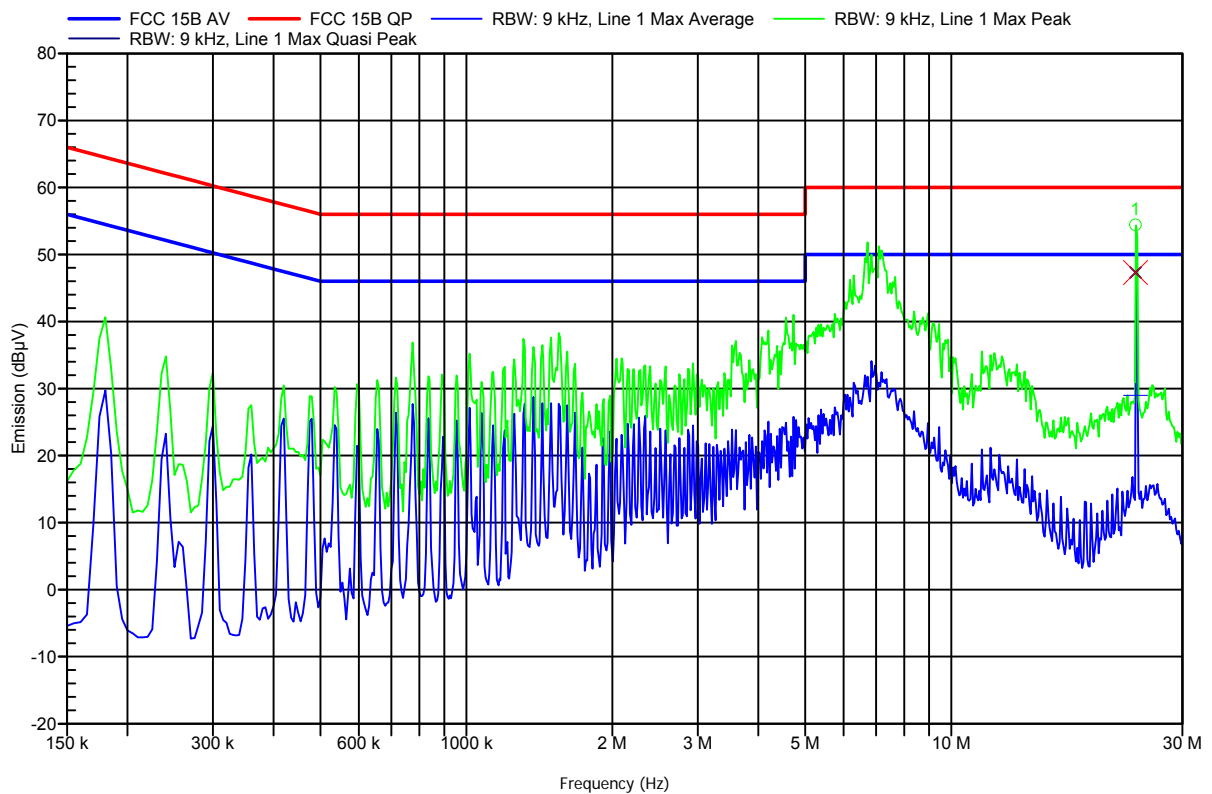

Frequency	Quasi-Peak	Quasi-Peak Limit	Quasi-Peak Difference	Status
23.99 MHz	47.31 dBµV	60 dBµV	-12.69 dB	Pass

Frequency	Average	Average Limit	Average Difference	Status
23.99 MHz	28.98 dBµV	50 dBµV	-21.02 dB	Pass

**EMI voltage test in the ac-mains according to FCC Part 15b**

Order number: G0M21006-3316

Manufacturer: Polycom Inc  
 EUT Name: DECT telephone handset  
 Model: 60xx and 70xx  
 Test Site: Eurofins Product Service GmbH  
 Operator: Mr. Marquardt  
 Test Conditions: Tnom: 23°C, Unom: 120 VAC  
 LISN: ESH2-Z5 N  
 Mode: charging, DECT link (worst case)  
 Test Date: 26.08.2010  
 Note: 70xx USB VER. + 7040

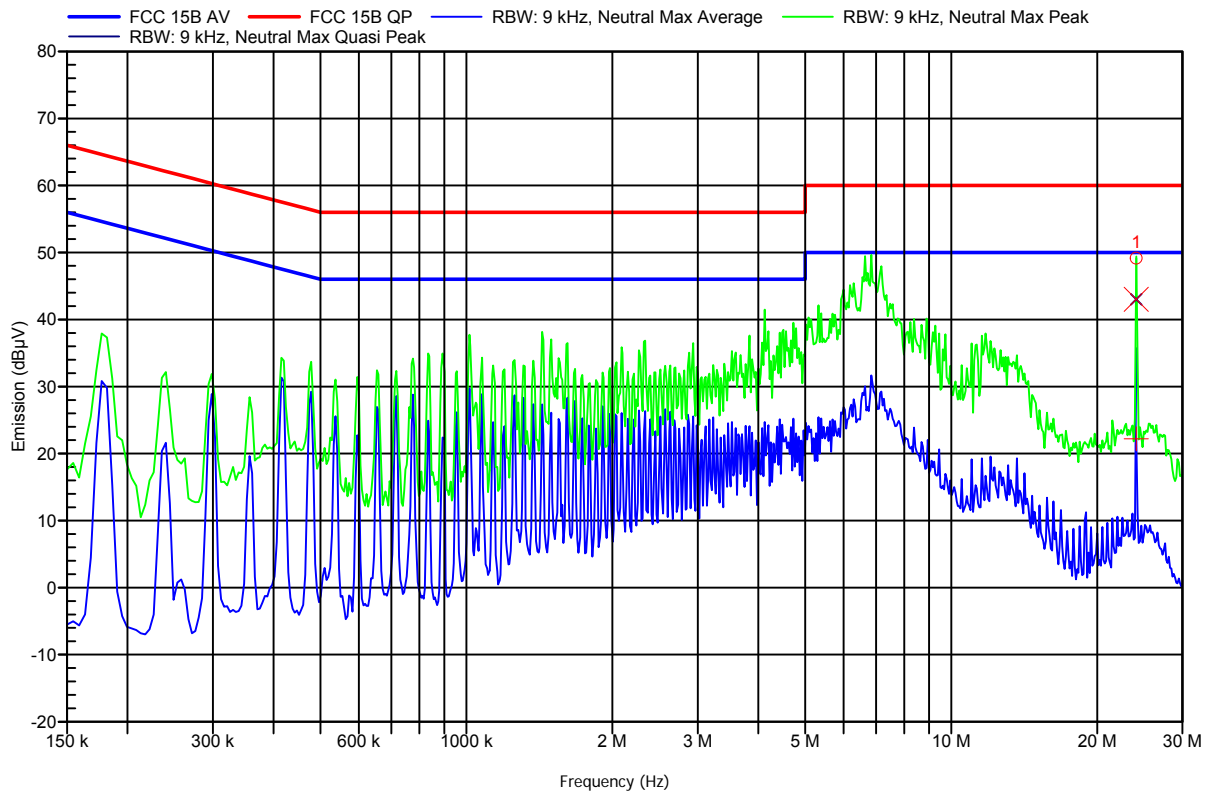

Frequency	Quasi-Peak	Quasi-Peak Limit	Quasi-Peak Difference	Status
24.077 MHz	43.01 dBµV	60 dBµV	-16.99 dB	Pass

Frequency	Average	Average Limit	Average Difference	Status
24.077 MHz	22.2 dBµV	50 dBµV	-27.8 dB	Pass

**EMI voltage test in the ac-mains according to FCC Part 15b**

Order number: G0M21006-3316

Manufacturer: Polycom Inc  
 EUT Name: DECT telephone handset  
 Model: 60xx and 70xx  
 Test Site: Eurofins Product Service GmbH  
 Operator: Mr. Marquardt  
 Test Conditions: Tnom: 23°C, Unom: 120 VAC  
 LISN: ESH2-Z5 L  
 Mode: charging, DECT link (worst case)  
 Test Date: 26.08.2010  
 Note: 60xx USB VER. + 6040

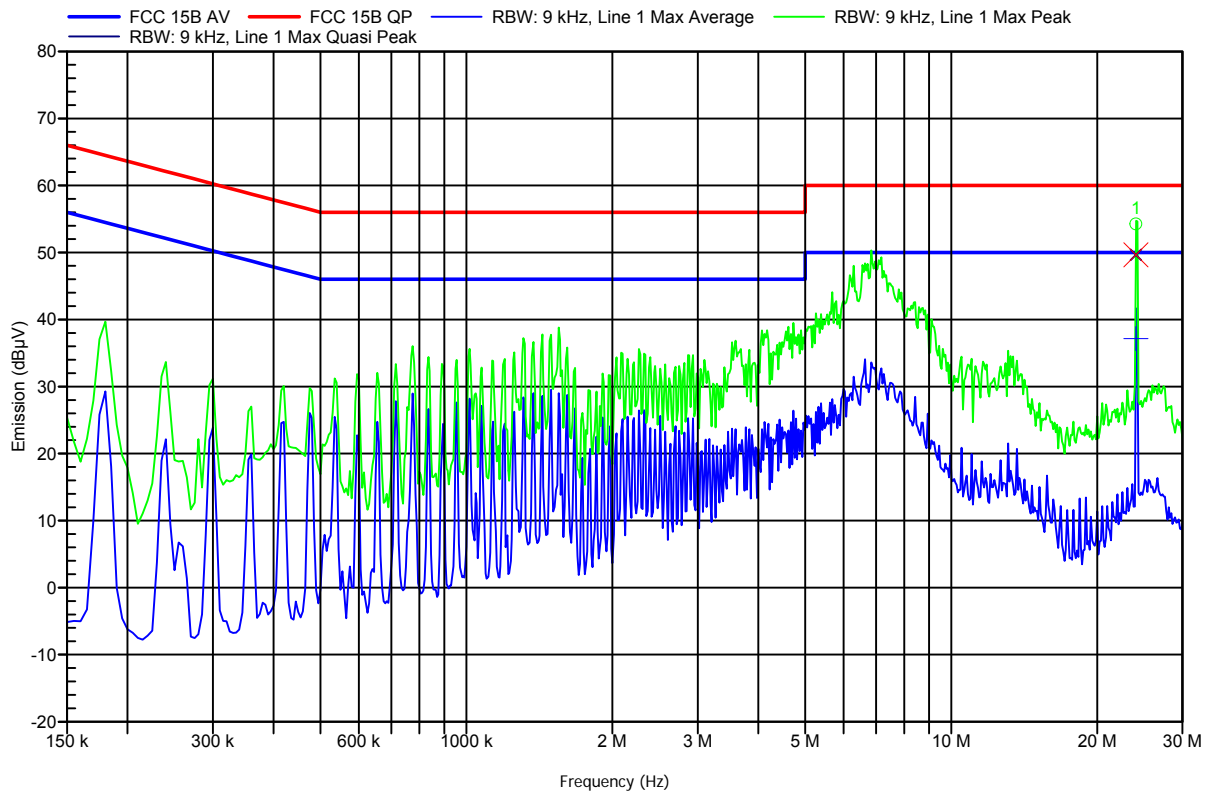

Frequency	Quasi-Peak	Quasi-Peak Limit	Quasi-Peak Difference	Status
24.035 MHz	49.65 dBµV	60 dBµV	-10.35 dB	Pass

Frequency	Average	Average Limit	Average Difference	Status
24.035 MHz	37.16 dBµV	50 dBµV	-12.84 dB	Pass



**EMI voltage test in the ac-mains according to FCC Part 15b**

Order number: G0M21006-3316

Manufacturer: Polycom Inc  
 EUT Name: DECT telephone handset  
 Model: 60xx and 70xx  
 Test Site: Eurofins Product Service GmbH  
 Operator: Mr. Marquardt  
 Test Conditions: Tnom: 23°C, Unom: 120 VAC  
 LISN: ESH2-Z5 N  
 Mode: charging, DECT link (worst case)  
 Test Date: 26.08.2010  
 Note: 60xx USB VER. + 6040

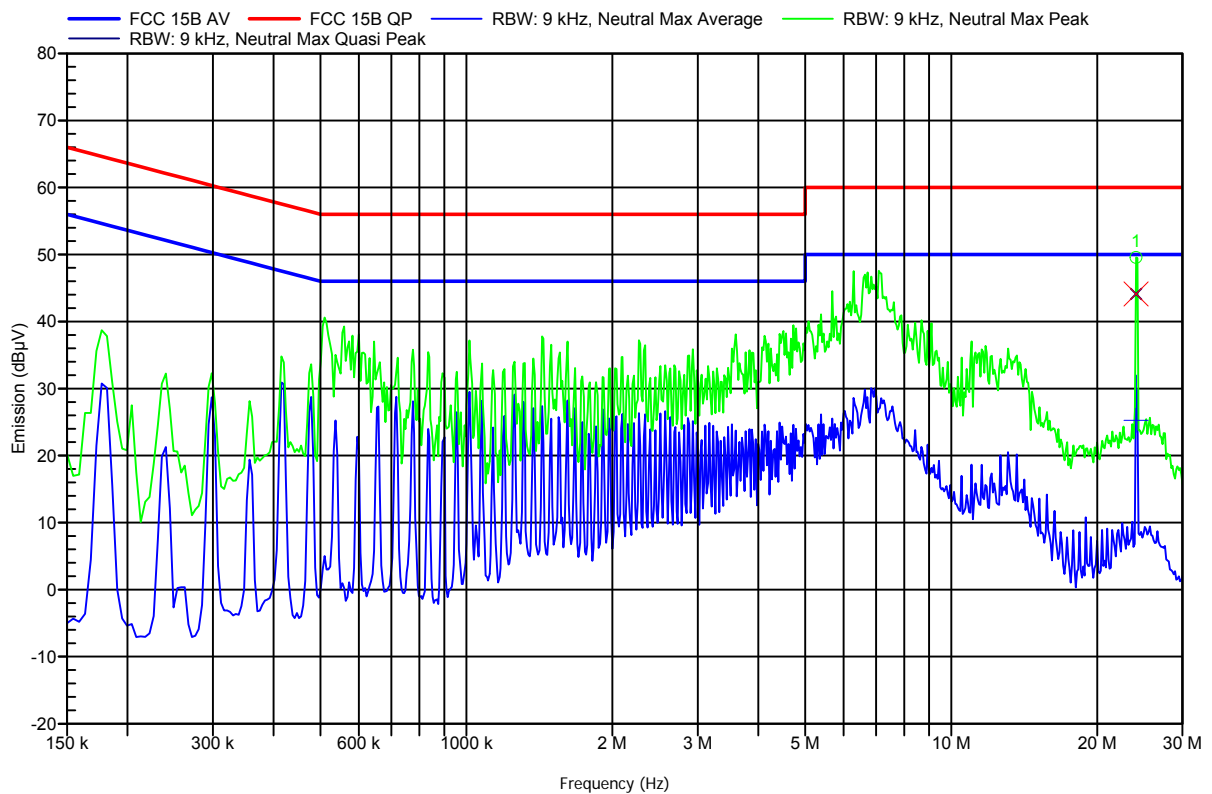

Frequency	Quasi-Peak	Quasi-Peak Limit	Quasi-Peak Difference	Status
24.054 MHz	44.12 dBµV	60 dBµV	-15.88 dB	Pass

Frequency	Average	Average Limit	Average Difference	Status
24.054 MHz	25.26 dBµV	50 dBµV	-24.74 dB	Pass

## Annex H Transmitter conducted spurious emissions

### FCC part 15.247 (d) Spurious Emissions

EUT	DECT 6.0 Handset
Model	6040 / mode: Bluetooth
Approval Holder	Polycom Denmark ApS / Ord.: G0M21006-3316
Temperature / Voltage	23°C / Vnom
Test Site / Operator	Eurofins Product Service GmbH / Mr. Treffke
Test Specification	FCC part 15.247 (d)
Comment 1	Spurious Emissions conducted
Comment 2	Channel : 2402 MHz
Comment 3	GFSK / DH5

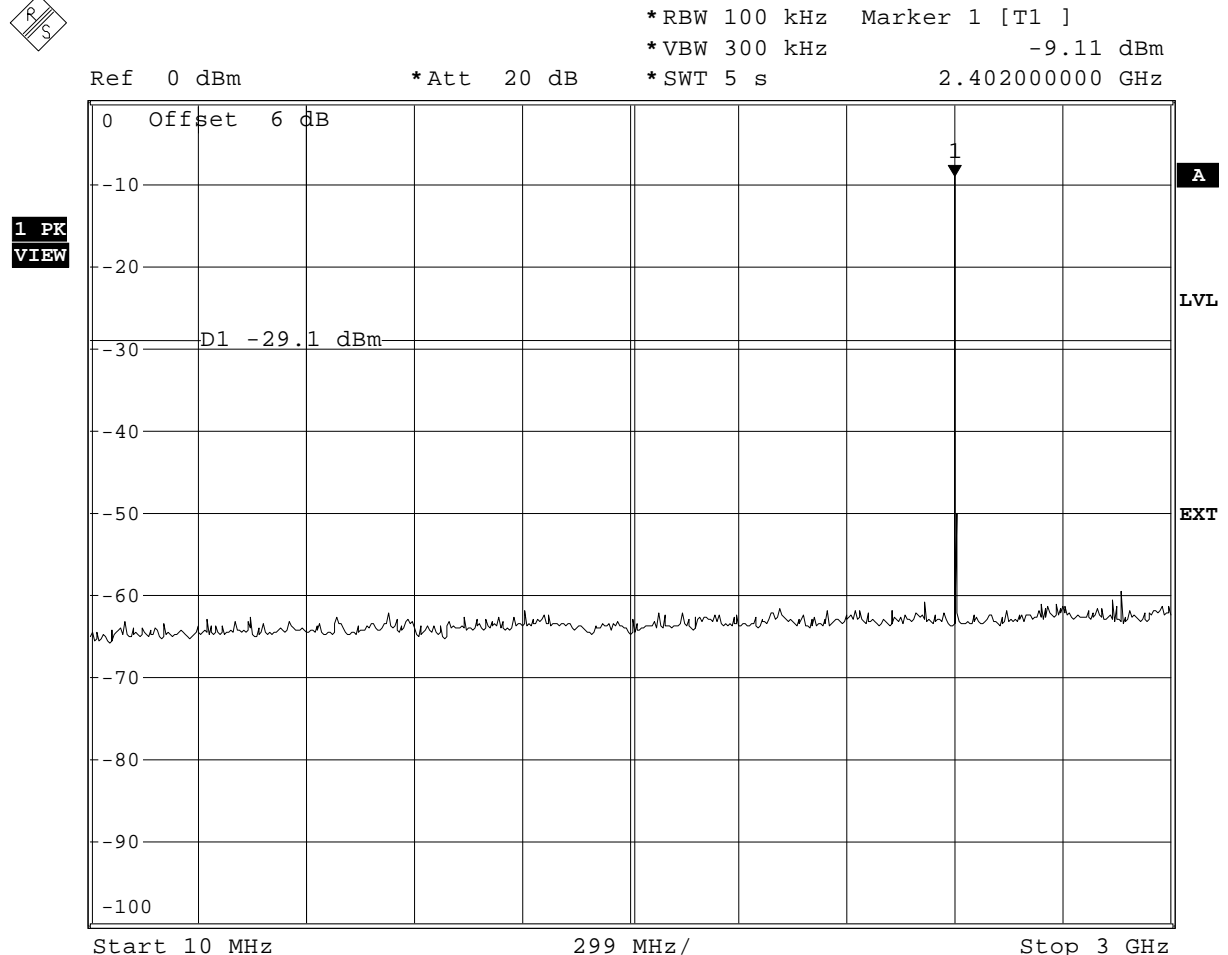

Date: 21.SEP.2010 12:58:08

Test Report No.: G0M21006-3316-P-15

Eurofins Product Service GmbH  
 Storkower Str. 38c, D-15526 Reichenwalde, Germany

Page 69 of 117

**FCC part 15.247 (d)  
Spurious Emissions**

EUT	DECT 6.0 Handset
Model	6040 / mode: Bluetooth
Approval Holder	Polycom Denmark ApS / Ord.: G0M21006-3316
Temperature / Voltage	23°C / Vnom
Test Site / Operator	Eurofins Product Service GmbH / Mr. Treffke
Test Specification	FCC part 15.247 (d)
Comment 1	Spurious Emissions conducted
Comment 2	Channel : 2402 MHz
Comment 3	GFSK / DH5

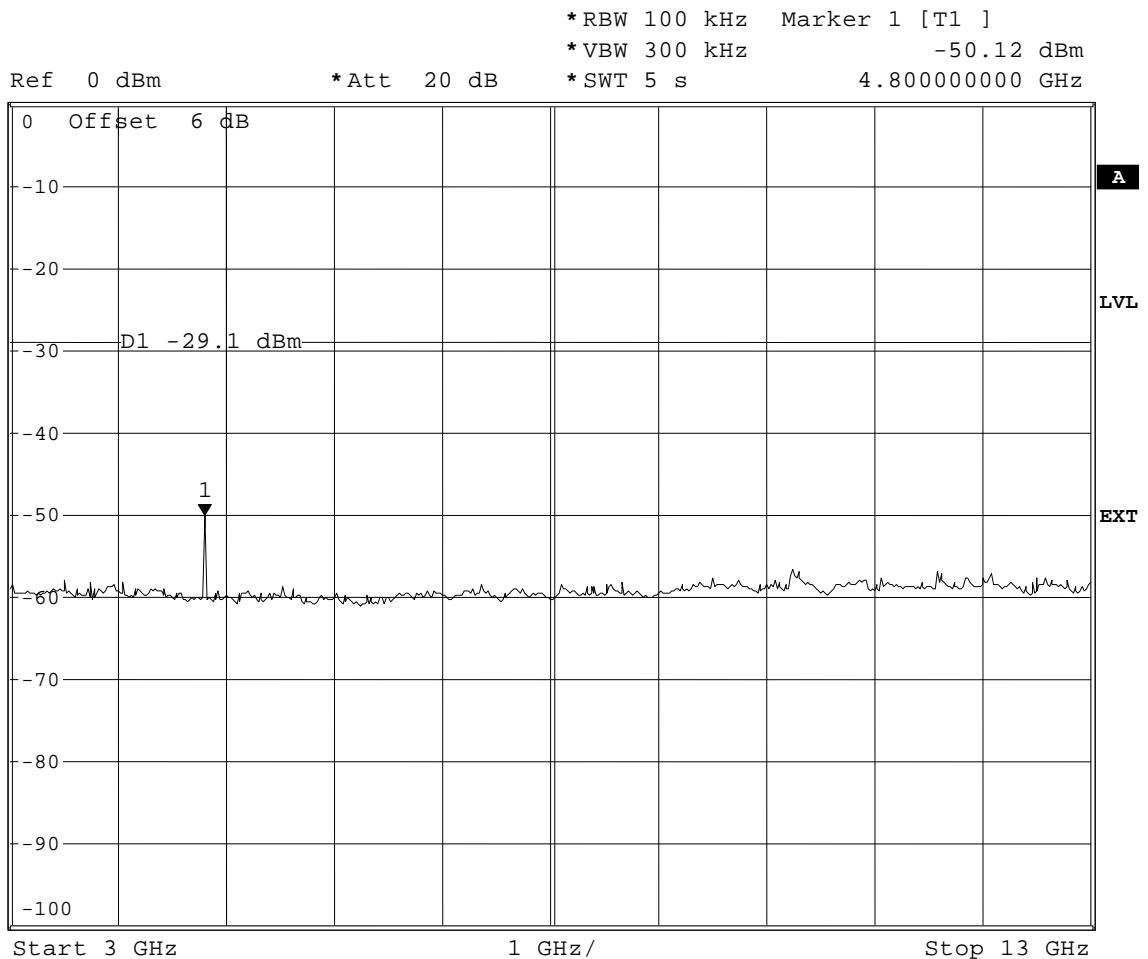

Date: 21.SEP.2010 13:27:48

**FCC part 15.247 (d)  
Spurious Emissions**

EUT	DECT 6.0 Handset
Model	6040 / mode: Bluetooth
Approval Holder	Polycom Denmark ApS / Ord.: G0M21006-3316
Temperature / Voltage	23°C / Vnom
Test Site / Operator	Eurofins Product Service GmbH / Mr. Treffke
Test Specification	FCC part 15.247 (d)
Comment 1	Spurious Emissions conducted
Comment 2	Channel : 2402 MHz
Comment 3	GFSK / DH5

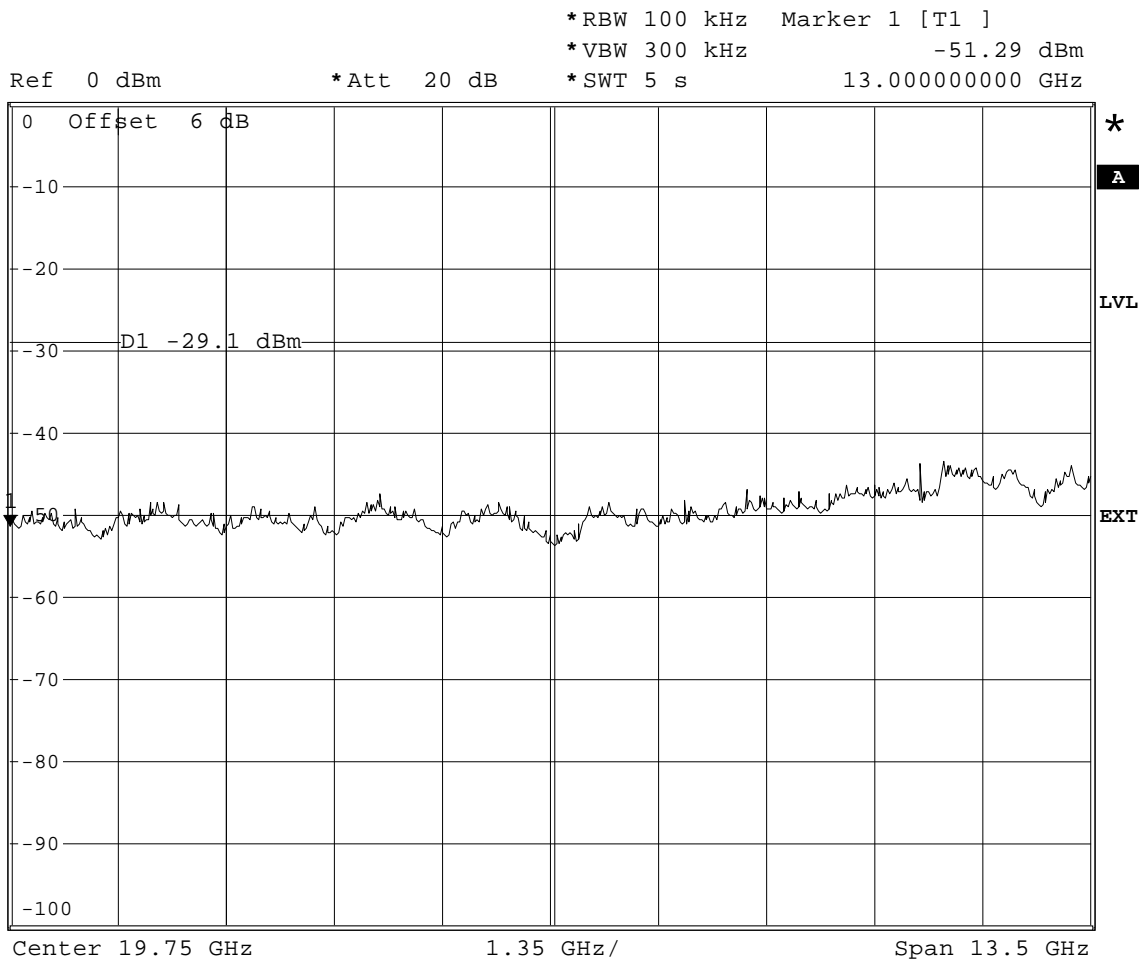

Date: 21.SEP.2010 13:28:42

---

 Test Report No.: G0M21006-3316-P-15

 Eurofins Product Service GmbH  
 Storkower Str. 38c, D-15526 Reichenwalde, Germany

Page 71 of 117

**FCC part 15.247 (d)  
Spurious Emissions**

EUT	DECT 6.0 Handset
Model	6040 / mode: Bluetooth
Approval Holder	Polycom Denmark ApS / Ord.: G0M21006-3316
Temperature / Voltage	23°C / Vnom
Test Site / Operator	Eurofins Product Service GmbH / Mr. Treffke
Test Specification	FCC part 15.247 (d)
Comment 1	Spurious Emissions conducted
Comment 2	Channel : 2441 MHz
Comment 3	GFSK / DH5

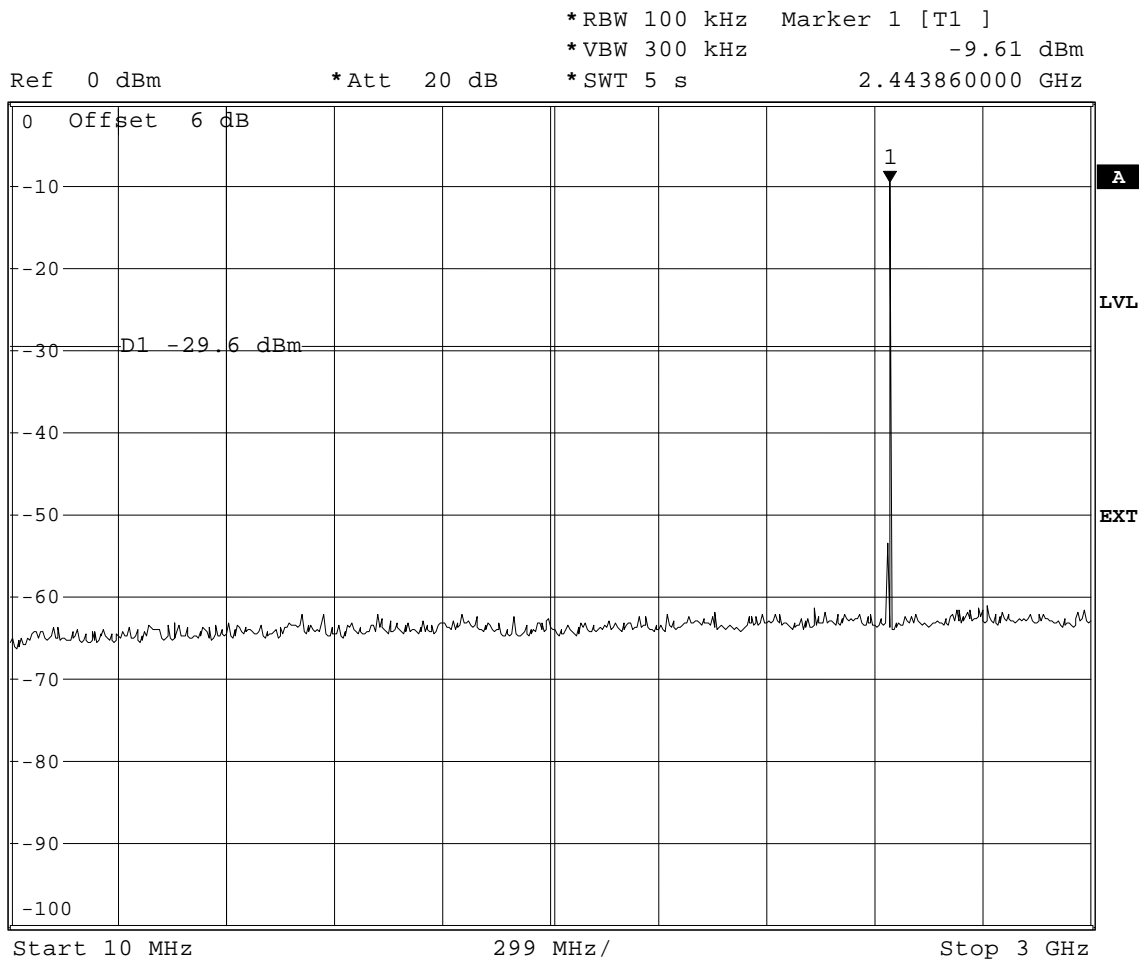

Date: 21.SEP.2010 13:54:11

**FCC part 15.247 (d)  
Spurious Emissions**

EUT	DECT 6.0 Handset
Model	6040 / mode: Bluetooth
Approval Holder	Polycom Denmark ApS / Ord.: G0M21006-3316
Temperature / Voltage	23°C / Vnom
Test Site / Operator	Eurofins Product Service GmbH / Mr. Treffke
Test Specification	FCC part 15.247 (d)
Comment 1	Spurious Emissions conducted
Comment 2	Channel : 2441 MHz
Comment 3	GFSK / DH5

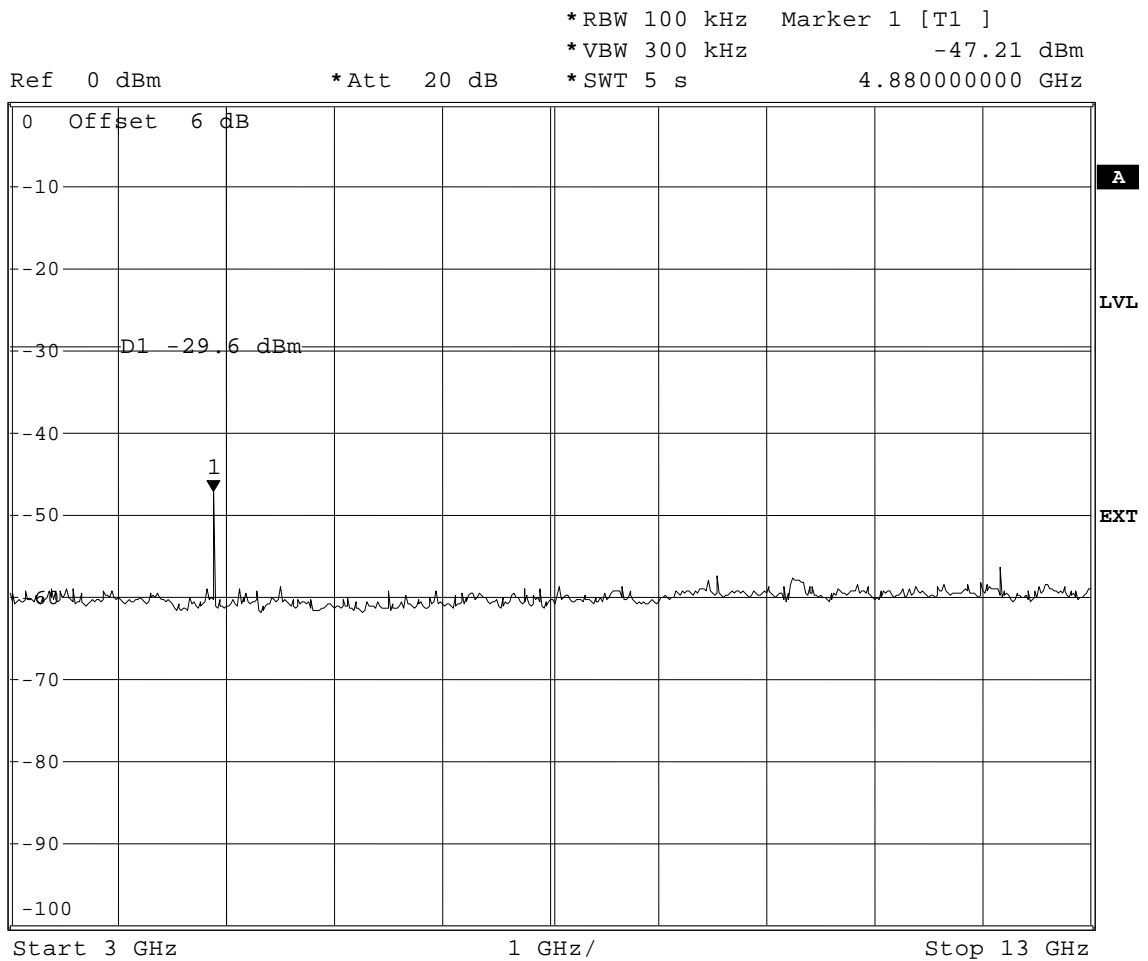

Date: 21.SEP.2010 13:56:50

**FCC part 15.247 (d)  
Spurious Emissions**

EUT	DECT 6.0 Handset
Model	6040 / mode: Bluetooth
Approval Holder	Polycom Denmark ApS / Ord.: G0M21006-3316
Temperature / Voltage	23°C / Vnom
Test Site / Operator	Eurofins Product Service GmbH / Mr. Treffke
Test Specification	FCC part 15.247 (d)
Comment 1	Spurious Emissions conducted
Comment 2	Channel : 2441 MHz
Comment 3	GFSK / DH5



\*RBW 100 kHz  
\*VBW 300 kHz  
\*SWT 5 s

Ref 0 dBm

\*Att 20 dB

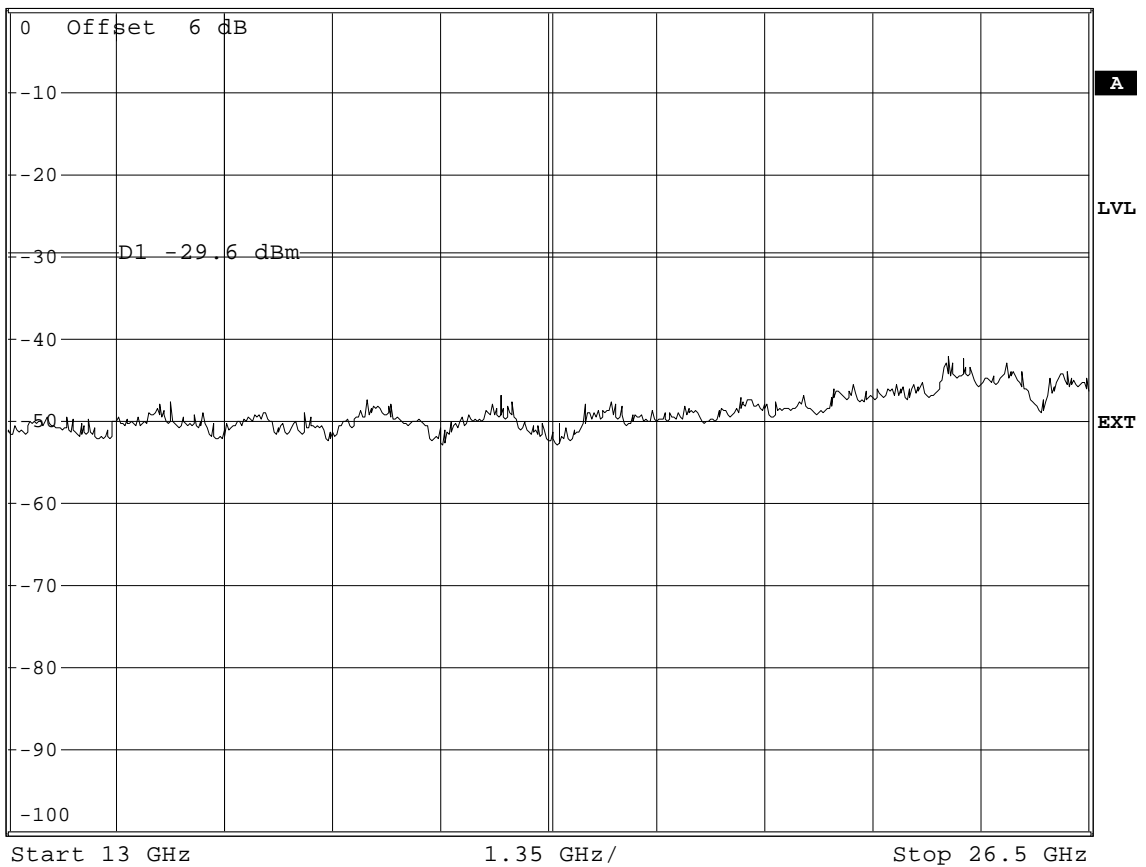
**1 PK  
VIEW**

Date: 21.SEP.2010 13:58:15

---

 Test Report No.: G0M21006-3316-P-15

 Eurofins Product Service GmbH  
 Storkower Str. 38c, D-15526 Reichenwalde, Germany

Page 74 of 117

**FCC part 15.247 (d)  
Spurious Emissions**

EUT	DECT 6.0 Handset
Model	6040 / mode: Bluetooth
Approval Holder	Polycom Denmark ApS / Ord.: G0M21006-3316
Temperature / Voltage	23°C / Vnom
Test Site / Operator	Eurofins Product Service GmbH / Mr. Treffke
Test Specification	FCC part 15.247 (d)
Comment 1	Spurious Emissions conducted
Comment 2	Channel : 2480 MHz
Comment 3	GFSK / DH5

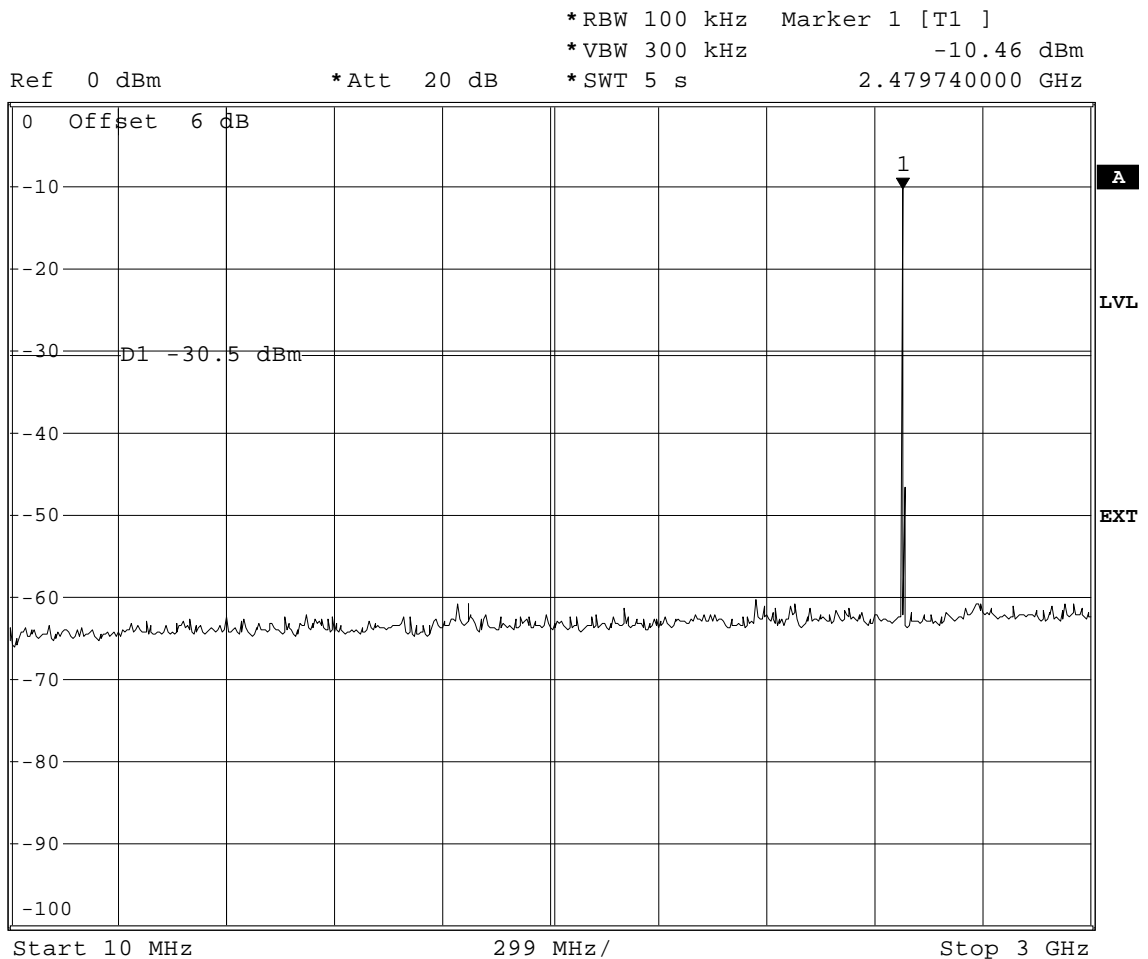

Date: 21.SEP.2010 13:34:14



**FCC part 15.247 (d)  
Spurious Emissions**

EUT	DECT 6.0 Handset
Model	6040 / mode: Bluetooth
Approval Holder	Polycom Denmark ApS / Ord.: G0M21006-3316
Temperature / Voltage	23°C / Vnom
Test Site / Operator	Eurofins Product Service GmbH / Mr. Treffke
Test Specification	FCC part 15.247 (d)
Comment 1	Spurious Emissions conducted
Comment 2	Channel : 2480 MHz
Comment 3	GFSK / DH5

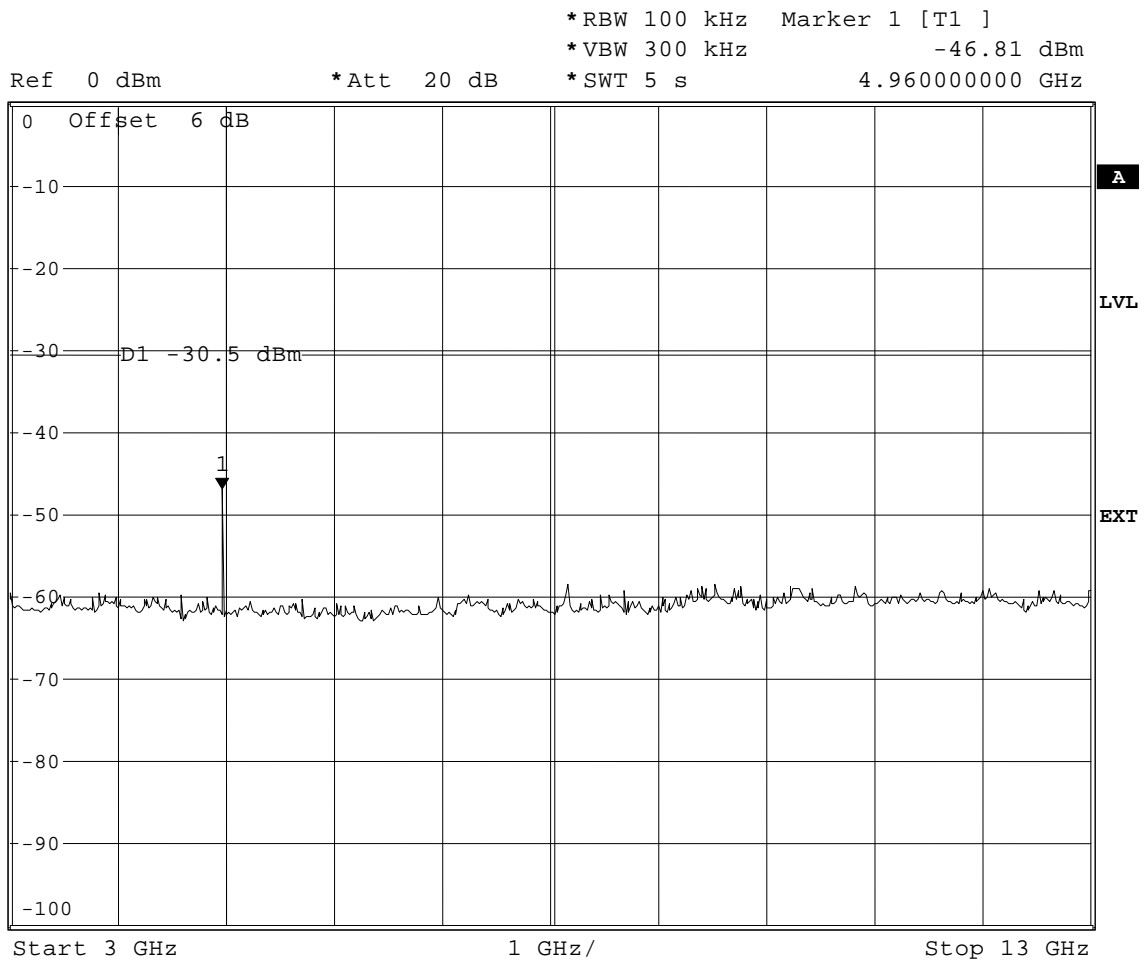

Date: 21.SEP 2010 13:52:16

---

 Test Report No.: G0M21006-3316-P-15

 Eurofins Product Service GmbH  
 Storkower Str. 38c, D-15526 Reichenwalde, Germany

Page 76 of 117



## Annex I Band edge compliance

### FCC part 15.247

#### Band-edge compliance of RF conducted emissions

EUT	DECT 6.0 Handset
Model	6040 / mode: Bluetooth
Approval Holder	Polycom Denmark ApS / Ord.: G0M21006-3316
Temperature / Voltage	23°C / Vnom
Test Site / Operator	Eurofins Product Service GmbH / Mr. Treffke
Test Specification	FCC part 15 section 247(c)
Comment 1	Band-edge compliance
Comment 2	Channel.: 0 / 2402 MHz
Comment 3	Single frequency mode

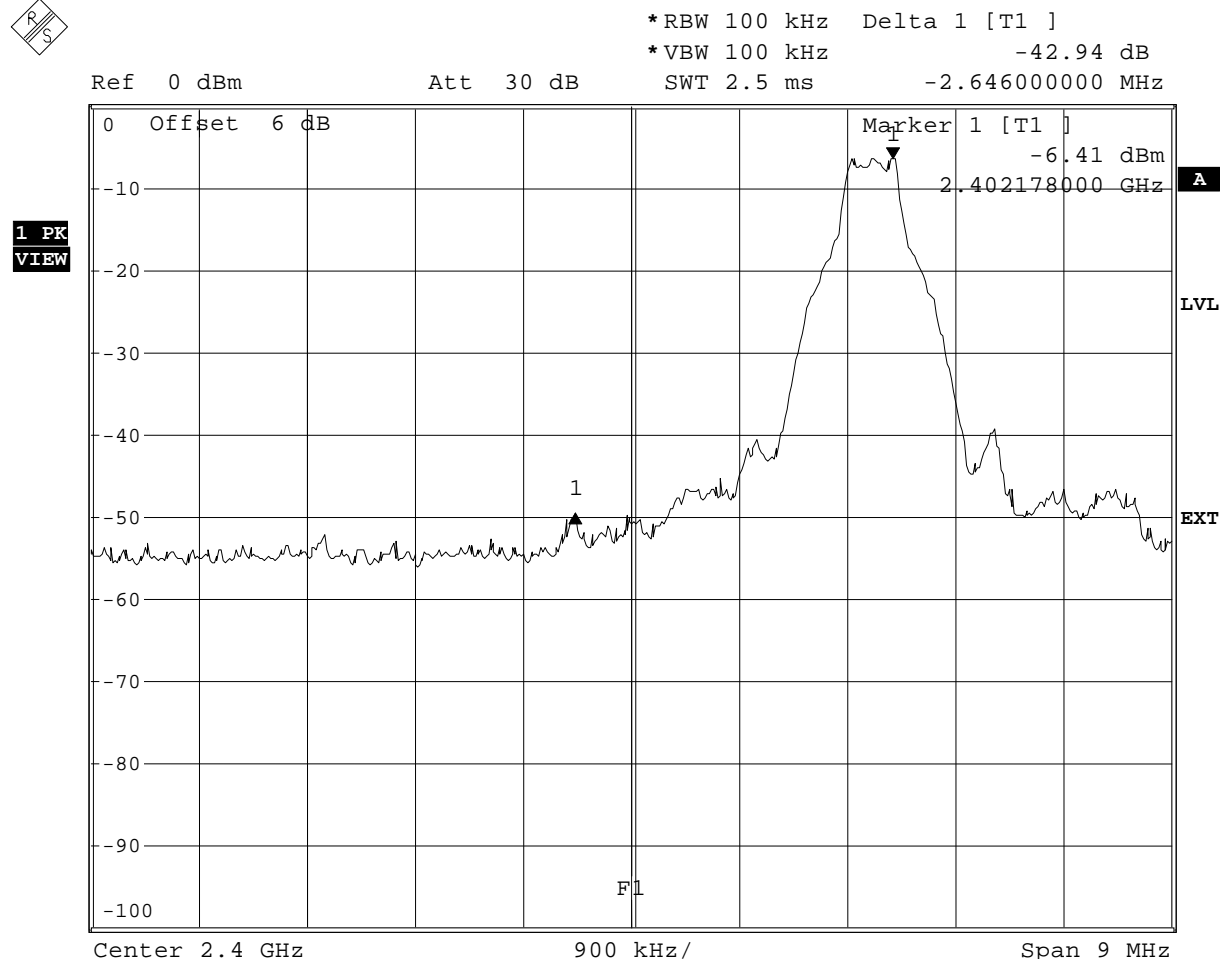

Date: 21.SEP.2010 10:08:55

Test Report No.: G0M21006-3316-P-15

Eurofins Product Service GmbH  
 Storkower Str. 38c, D-15526 Reichenwalde, Germany

Page 78 of 117

**FCC part 15.247**  
**Band-edge compliance of RF conducted emissions**

EUT	DECT 6.0 Handset
Model	6040 / mode: Bluetooth
Approval Holder	Polycom Denmark ApS / Ord.: G0M21006-3316
Temperature / Voltage	23°C / Vnom
Test Site / Operator	Eurofins Product Service GmbH / Mr. Treffke
Test Specification	FCC part 15 section 247(c)
Comment 1	Band-edge compliance
Comment 2	Channel.: 0 / 2402 MHz
Comment 3	Hopping mode

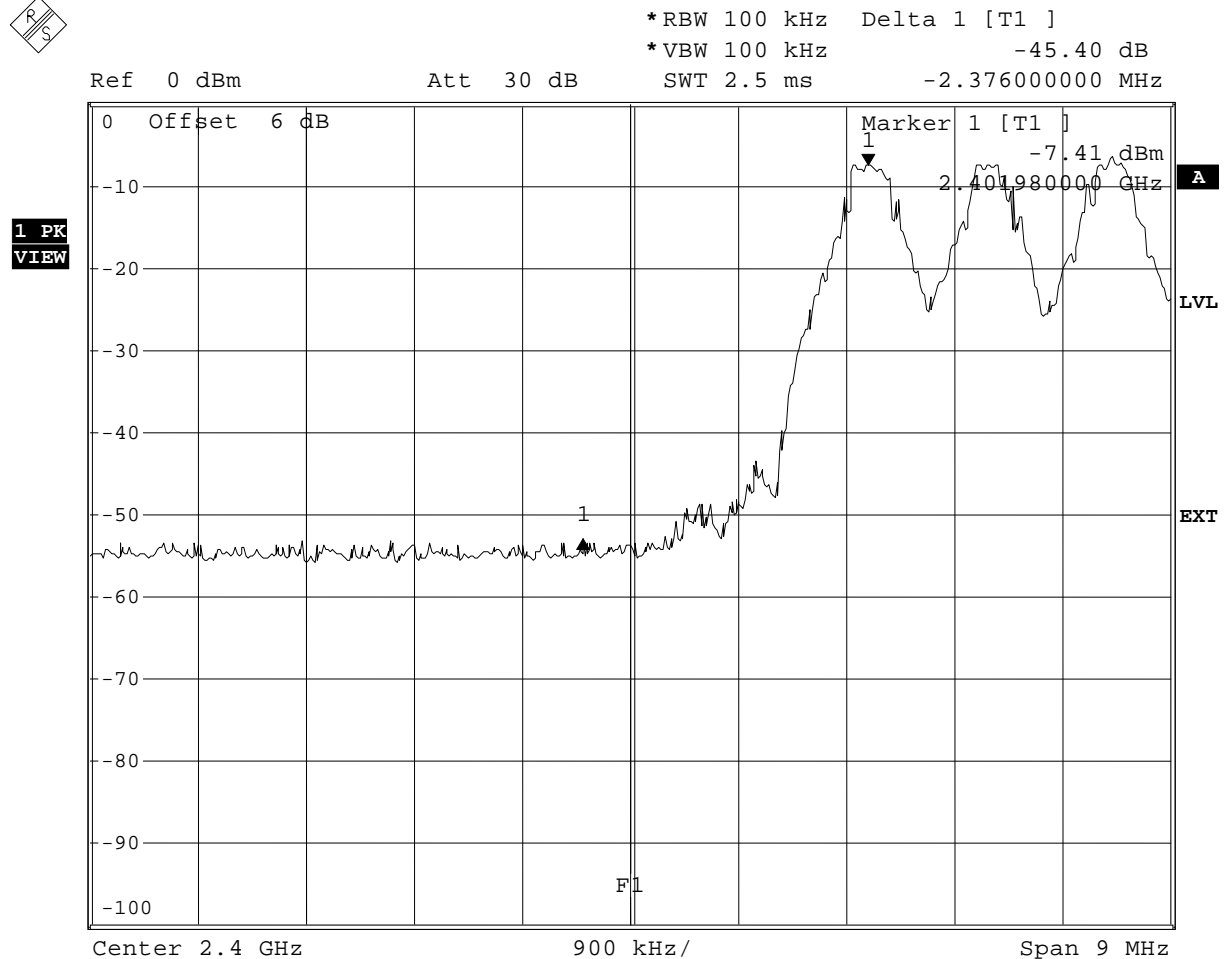

Comment: Limit: Marker Delta value >20 dB; Result: PASS  
 Date: 21.SEP.2010 10:21:36

**FCC part 15.247**  
**Band-edge compliance of RF conducted emissions**

EUT	DECT 6.0 Handset
Model	6040 / mode: Bluetooth
Approval Holder	Polycom Denmark ApS / Ord.: G0M21006-3316
Temperature / Voltage	23°C / Vnom
Test Site / Operator	Eurofins Product Service GmbH / Mr. Treffke
Test Specification	FCC part 15 section 247(c)
Comment 1	Band-edge compliance
Comment 2	Channel.: 78 / 2480 MHz
Comment 3	Single frequency mode

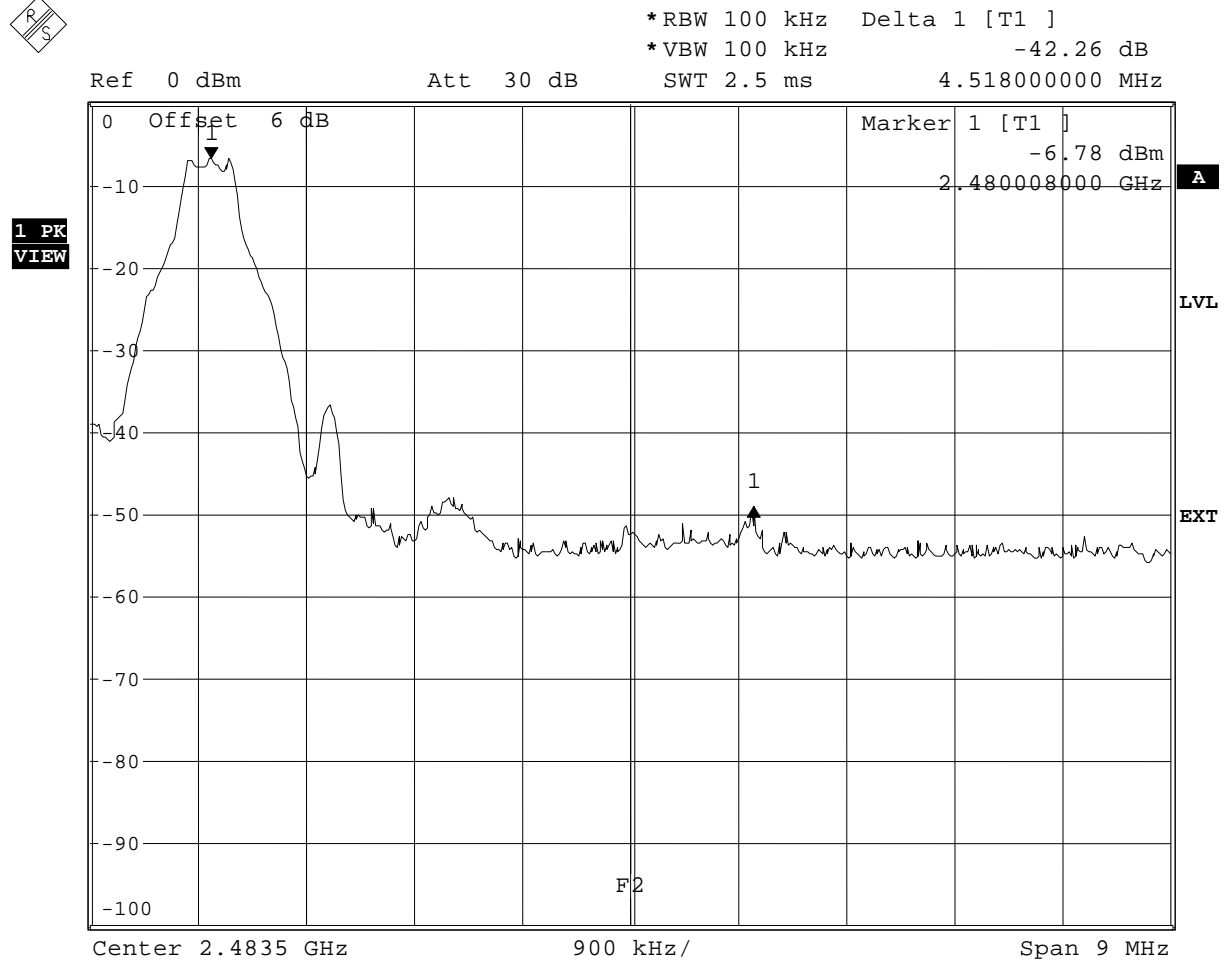

Date: 21.SEP.2010 10:11:49

Test Report No.: G0M21006-3316-P-15

 Eurofins Product Service GmbH  
 Storkower Str. 38c, D-15526 Reichenwalde, Germany

Page 80 of 117

**FCC part 15.247**  
**Band-edge compliance of RF conducted emissions**

EUT	DECT 6.0 Handset
Model	6040 / mode: Bluetooth
Approval Holder	Polycom Denmark ApS / Ord.: G0M21006-3316
Temperature / Voltage	23°C / Vnom
Test Site / Operator	Eurofins Product Service GmbH / Mr. Treffke
Test Specification	FCC part 15 section 247(c)
Comment 1	Band-edge compliance
Comment 2	Channel.: 78 / 2480 MHz
Comment 3	Hopping mode

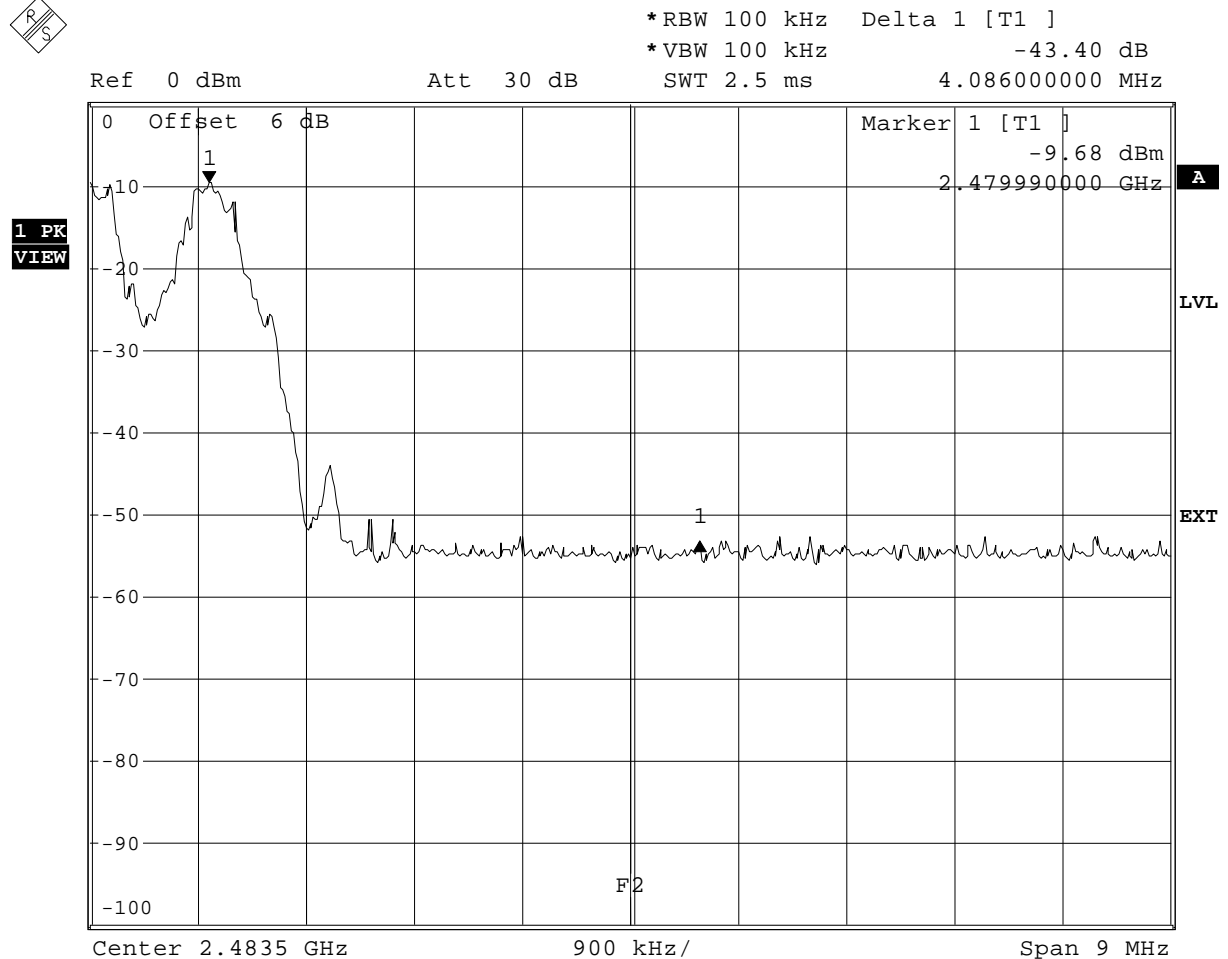

Comment: Limit: Marker Delta value >20 dB; Result: PASS  
 Date: 21.SEP.2010 11:00:28

## **Annex J Transmitter radiated spurious emissions**

# Spurious emissions Field Strength

## FCC RULES PART 15, SUBPART C

Approval Holder: Polycom Denmark ApS / Ord.: G0M21006-3316  
EUT: DECT 6.0 Handset  
Model: 6040 / 2402 MHz  
Test Site / Operator: Eurofins Product Service GmbH / Mr. Handrik  
Test Condition: Temp.: 23°C / Unom.: 3.7 V DC  
Test Specification: according to §15.247  
Comment 1: Dist.: 3m, Ant.: HK 116  
Comment 2: Freq: 200.000MHz, Emax: 34.18dBµV/m, RBW: 100kHz

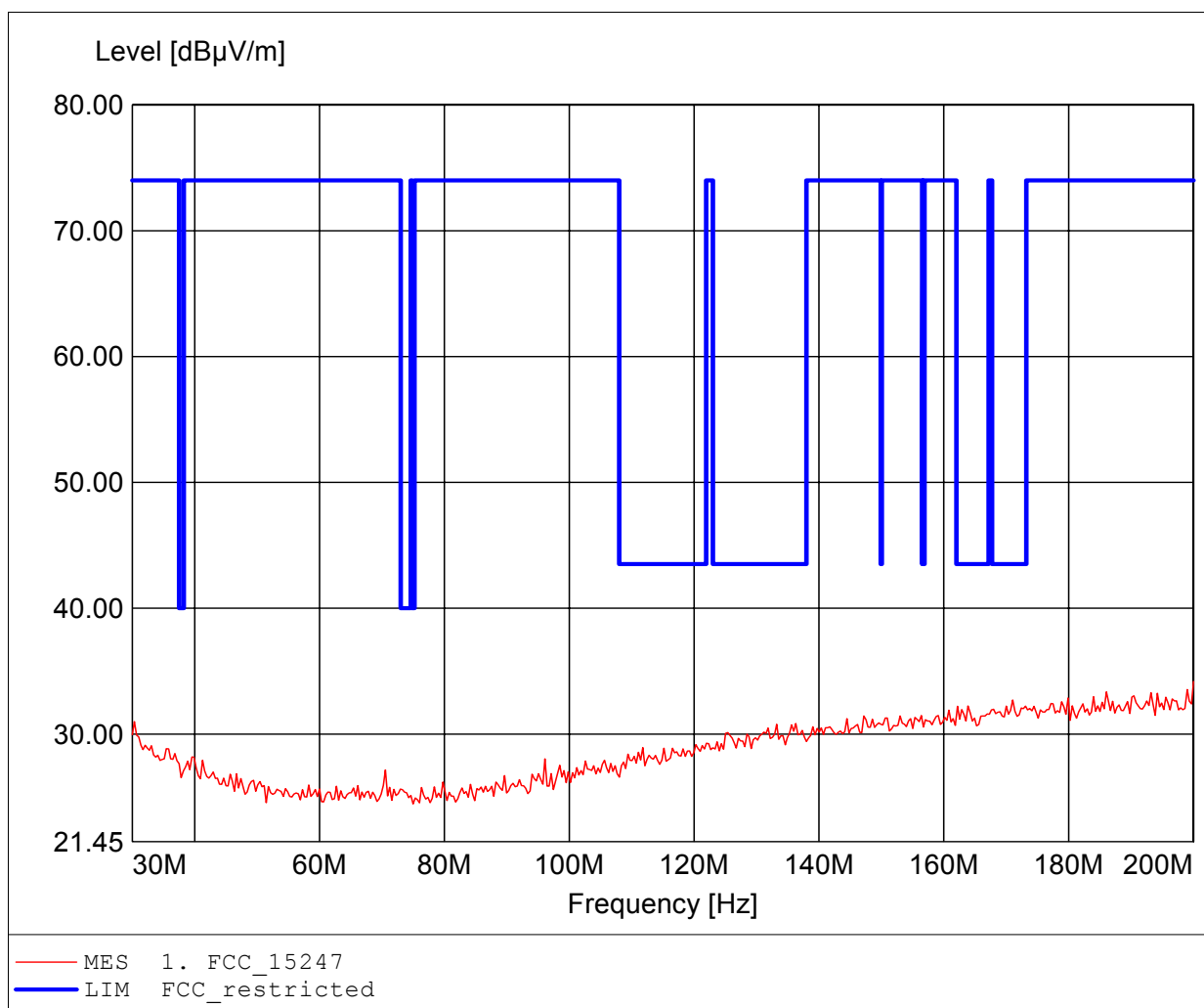



**Spurious emissions Field Strength**

**FCC RULES PART 15, SUBPART C**

Approval Holder: Polycom Denmark ApS / Ord.: G0M21006-3316  
EUT: DECT 6.0 Handset  
Model: 6040 / 2402 MHz  
Test Site / Operator: Eurofins Product Service GmbH / Mr. Handrik  
Test Condition: Temp.: 23°C / Unom.: 3.7 V DC  
Test Specification: according to §15.247  
Comment 1: Dist.: 3m, Ant.: HK 116  
Comment 2: Freq: 189.780MHz, Emax: 33.77dBµV/m, RBW: 100kHz

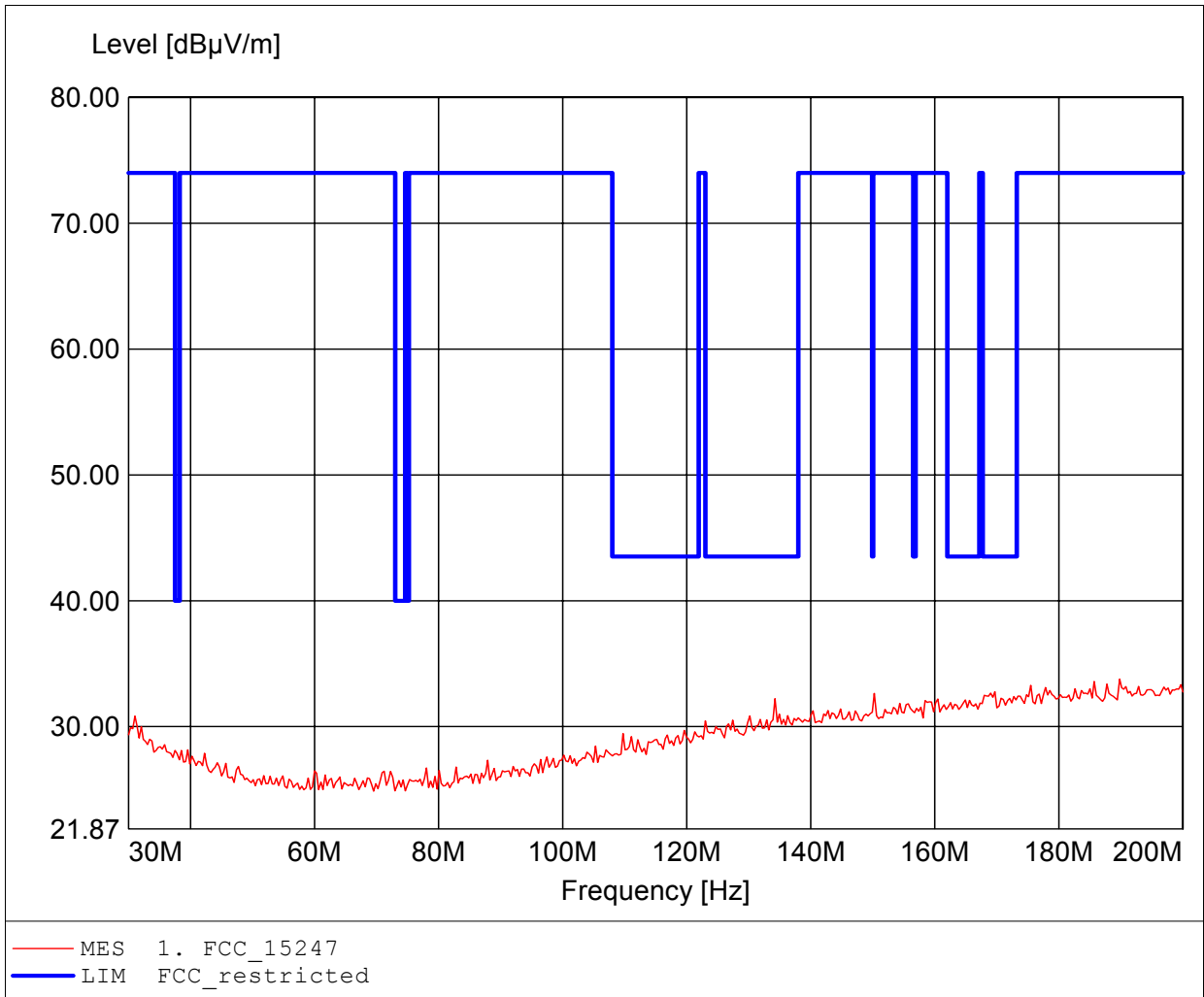

# Spurious emissions Field Strength

## FCC RULES PART 15, SUBPART C

Approval Holder: Polycom Denmark ApS / Ord.: G0M21006-3316  
EUT: DECT 6.0 Handset  
Model: 6040 / 2402 MHz  
Test Site / Operator: Eurofins Product Service GmbH / Mr. Handrik  
Test Condition: Temp.: 23°C / Unom.: 3.7 V DC  
Test Specification: according to §15.247  
Comment 1: Dist.: 3m, Ant.: HL 223, amplif.  
Comment 2: Freq: 913.427MHz, Emax: 29.40dBµV/m, RBW: 100kHz

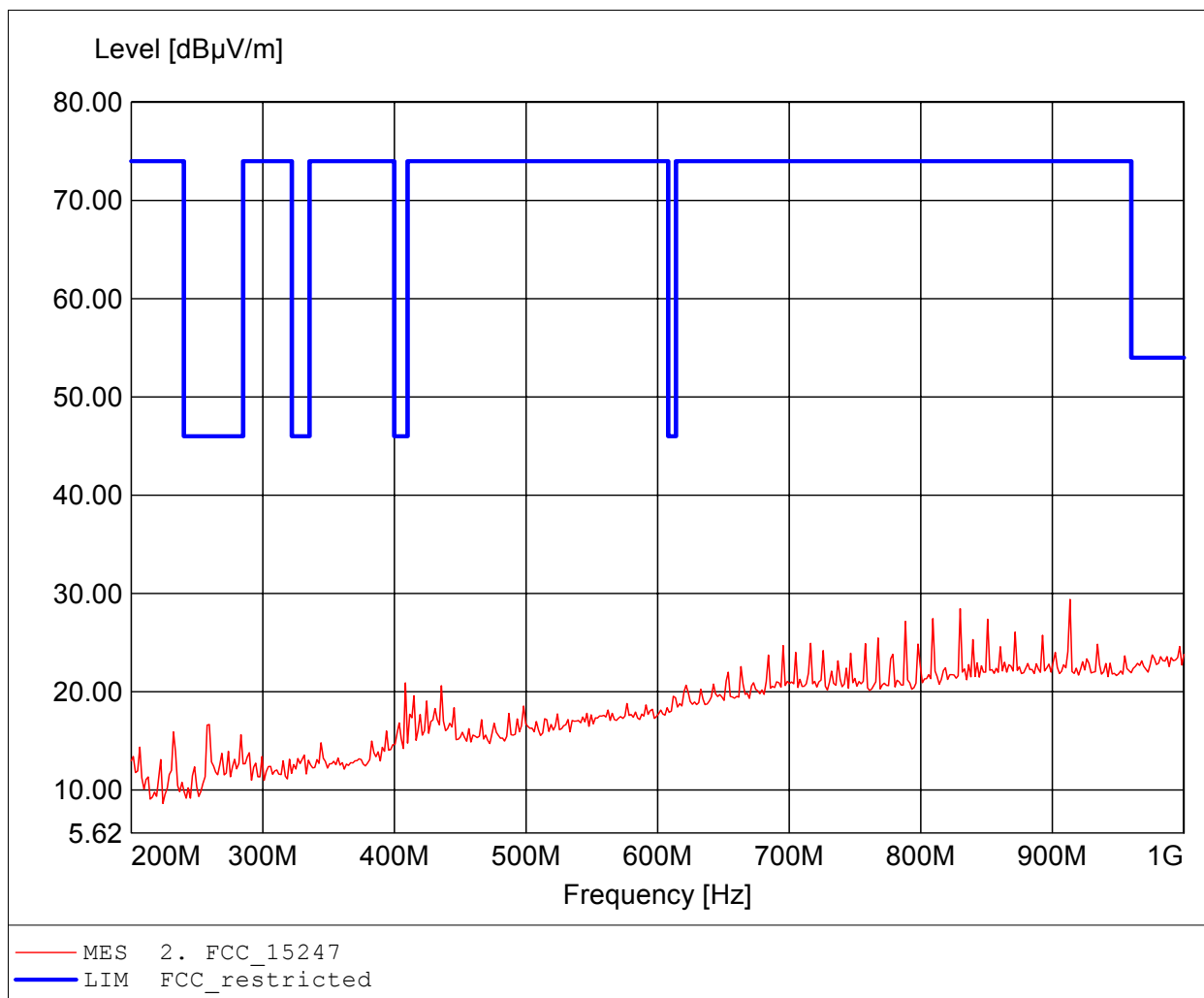

# Spurious emissions Field Strength

## FCC RULES PART 15, SUBPART C

Approval Holder: Polycom Denmark ApS / Ord.: G0M21006-3316  
EUT: DECT 6.0 Handset  
Model: 6040 / 2402 MHz  
Test Site / Operator: Eurofins Product Service GmbH / Mr. Handrik  
Test Condition: Temp.: 23°C / Unom.: 3.7 V DC  
Test Specification: according to §15.247  
Comment 1: Dist.: 3m, Ant.: HL 223, amplif.  
Comment 2: Freq: 892.585MHz, Emax: 23.93dBµV/m, RBW: 100kHz

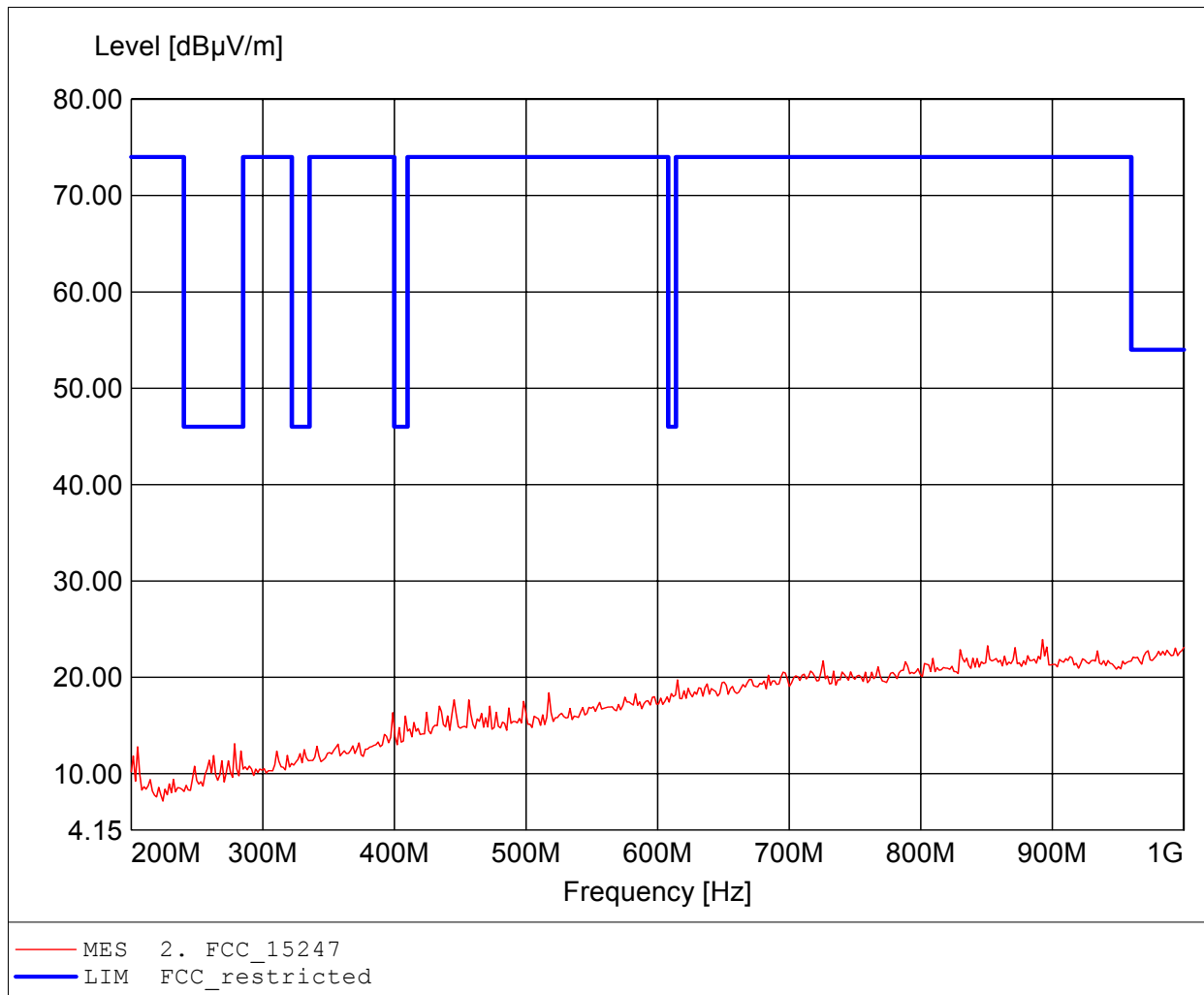

# Spurious emissions Field Strength

## FCC RULES PART 15, SUBPART C

Approval Holder: Polycom Denmark ApS / Ord.: G0M21006-3316  
EUT: DECT 6.0 Handset  
Model: 6040 / 2402 MHz  
Operator: Eurofins Product Service GmbH / Mr. Handrik  
Test Conditions: Tnom: 23°C / Unom: 3.7 V DC  
Test Specification: according to §15.247, peak detector  
Comment 1: Dist.: 3m, Ant.: H1 025, amplif.  
Comment 2: Freq: 2.400GHz, Emax: 47.89dBµV/m, RBW: 1MHz

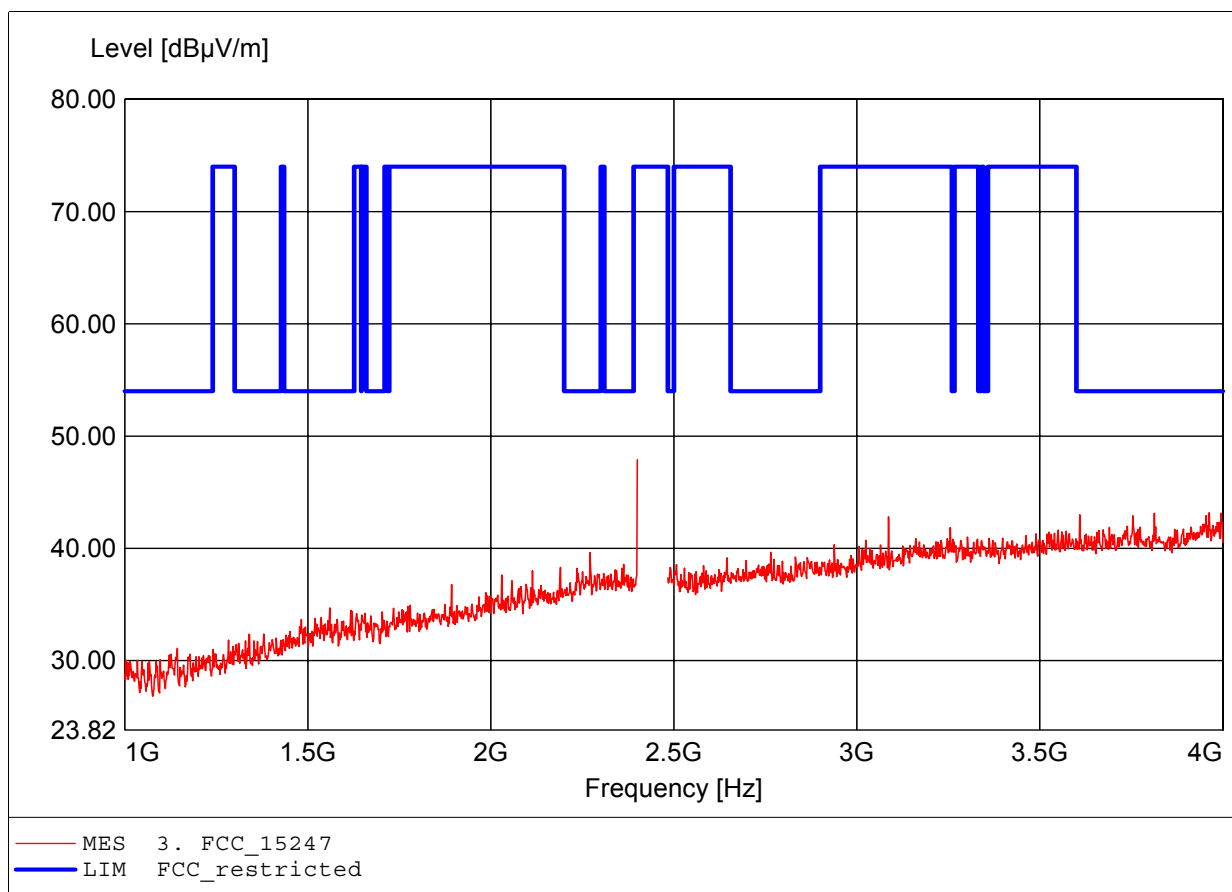

# Spurious emissions Field Strength

## FCC RULES PART 15, SUBPART C

Approval Holder: Polycom Denmark ApS / Ord.: G0M21006-3316  
EUT: DECT 6.0 Handset  
Model: 6040 / 2402 MHz  
Operator: Eurofins Product Service GmbH / Mr. Handrik  
Test Conditions: Tnom: 23°C / Unom: 3.7 V DC  
Test Specification: according to §15.247, peak detector  
Comment 1: Dist.: 3m, Ant.: H1 025, amplif.  
Comment 2: Freq: 2.400GHz, Emax: 47.11dBµV/m, RBW: 1MHz

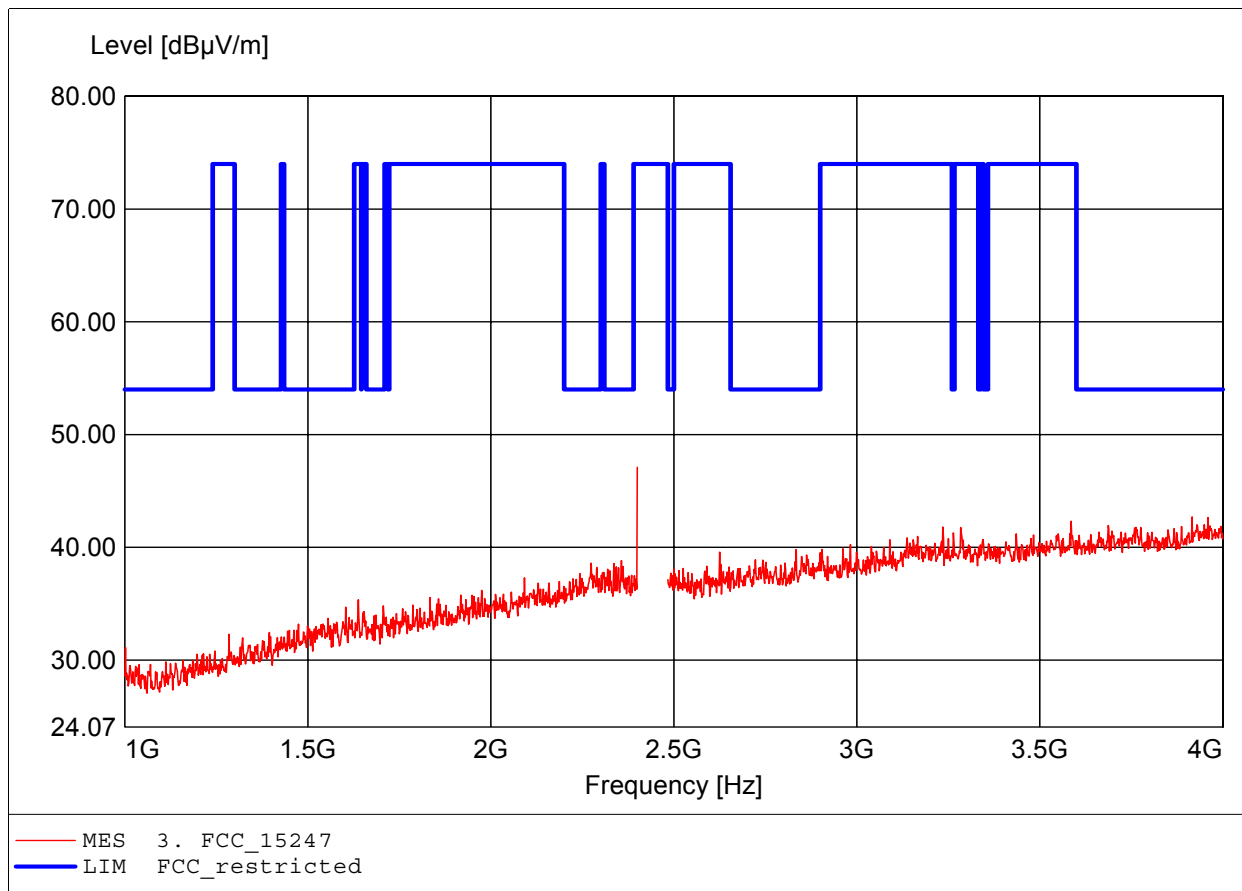

# Spurious emissions Field Strength

## FCC RULES PART 15, SUBPART C

Approval Holder: Polycom Denmark ApS / Ord.: G0M21006-3316  
EUT: DECT 6.0 Handset  
Model: 6040 / 2402 MHz  
Operator: Eurofins Product Service GmbH / Mr. Handrik  
Test Conditions: Tnom: 23°C / Unom: 3.7 V DC  
Test Specification: according to §15.247, peak detector  
Comment 1: Dist.: 3m, Ant.: H1 025, ampl.+HP.  
Comment 2: Freq: 7.822GHz, Emax: 48.00dBµV/m, RBW: 1MHz

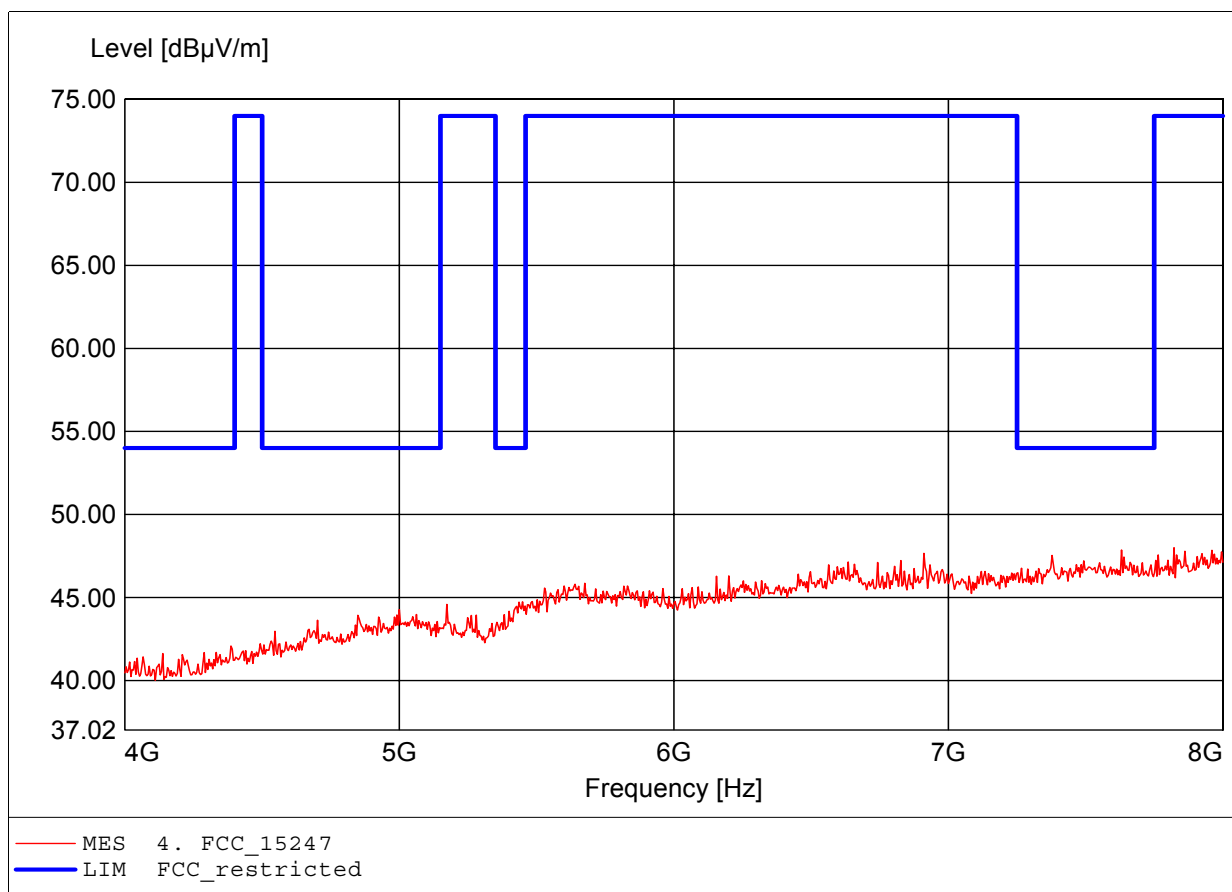

# Spurious emissions Field Strength

## FCC RULES PART 15, SUBPART C

Approval Holder: Polycom Denmark ApS / Ord.: G0M21006-3316  
EUT: DECT 6.0 Handset  
Model: 6040 / 2402 MHz  
Operator: Eurofins Product Service GmbH / Mr. Handrik  
Test Conditions: Tnom: 23°C / Unom: 3.7 V DC  
Test Specification: according to §15.247, peak detector  
Comment 1: Dist.: 3m, Ant.: H1 025, ampl.+HP.  
Comment 2: Freq: 7.907GHz, Emax: 48.28dBµV/m, RBW: 1MHz

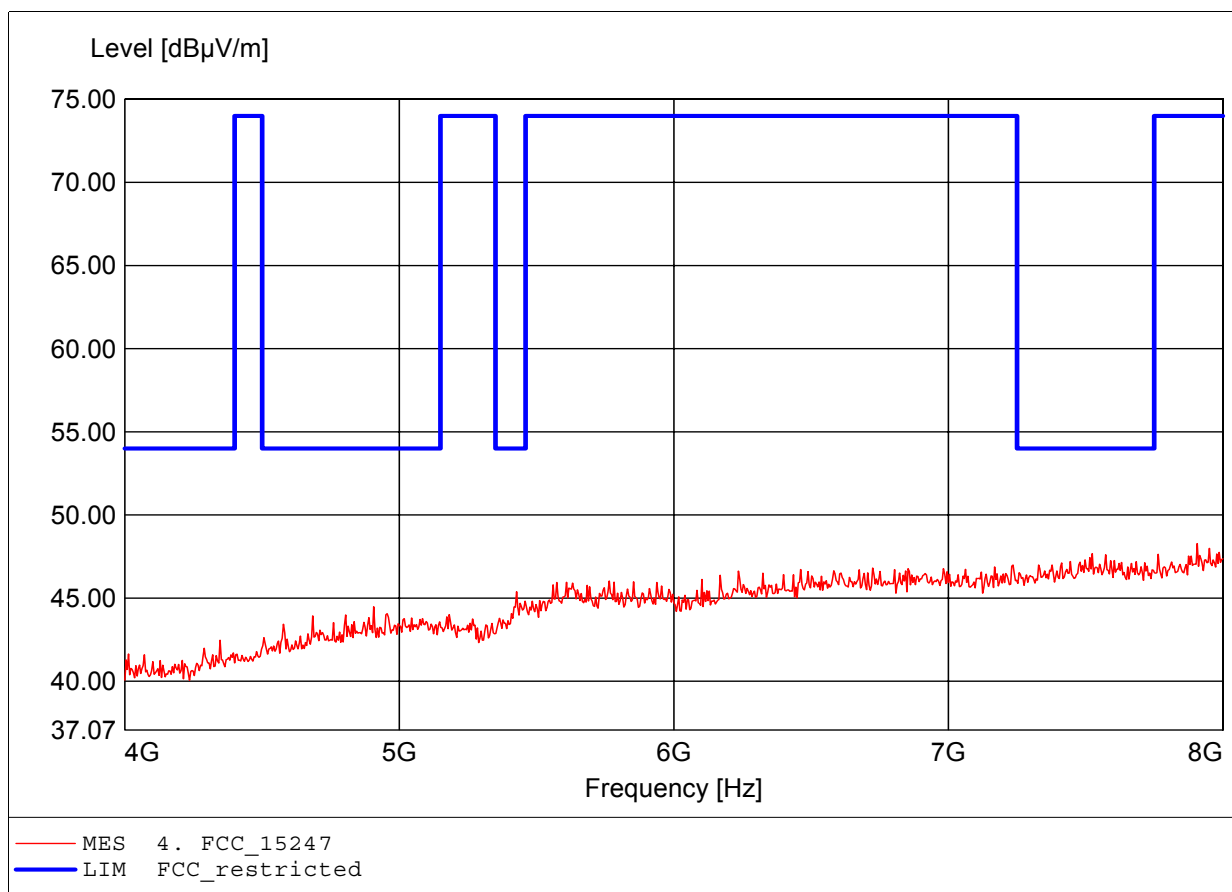

# Spurious emissions Field Strength

## FCC RULES PART 15, SUBPART C

Approval Holder: Polycom Denmark ApS / Ord.: G0M21006-3316  
EUT: DECT 6.0 Handset  
Model: 6040 / 2402 MHz  
Test Site / Operator: Eurofins Product Service GmbH / Mr. Handrik  
Test Condition: Temp.: 23°C / Unom.: 3.7 V DC  
Test Specification: according to §15.247, peak detector  
Comment 1: Dist.: 3m, Ant.: BBHA9120D, ampl.+HP.  
Comment 2: Freq: 11.423GHz, Emax: 43.77dBuV/m, RBW: 1MHz

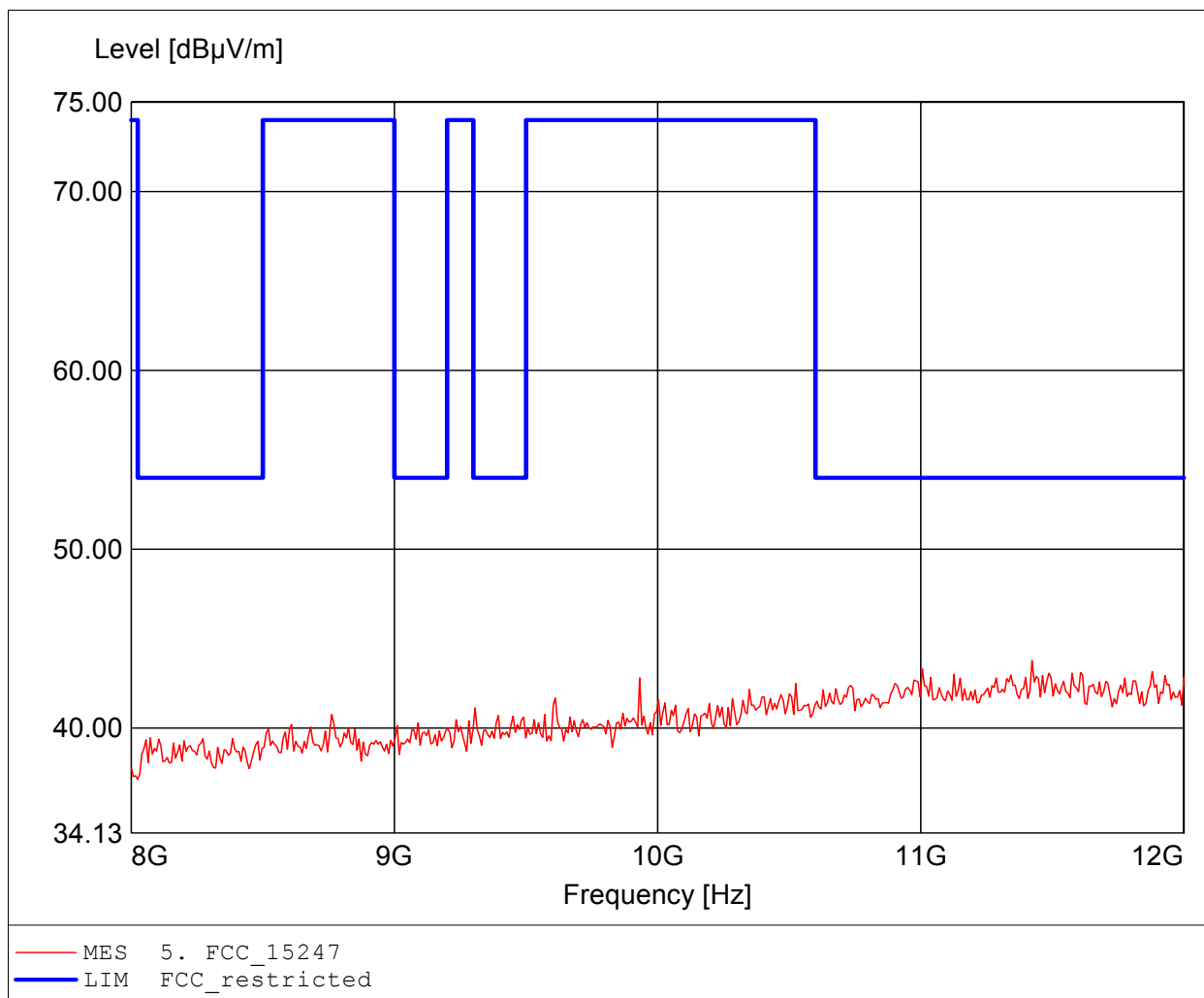



# Spurious emissions Field Strength

## FCC RULES PART 15, SUBPART C

Approval Holder: Polycom Denmark ApS / Ord.: G0M21006-3316  
EUT: DECT 6.0 Handset  
Model: 6040 / 2402 MHz  
Test Site / Operator: Eurofins Product Service GmbH / Mr. Handrik  
Test Condition: Temp.: 23°C / Unom.: 3.7 V DC  
Test Specification: according to §15.247, peak detector  
Comment 1: Dist.: 3m, Ant.: BBHA9120D, ampl.+HP.  
Comment 2: Freq: 11.287GHz, Emax: 43.52dBµV/m, RBW: 1MHz

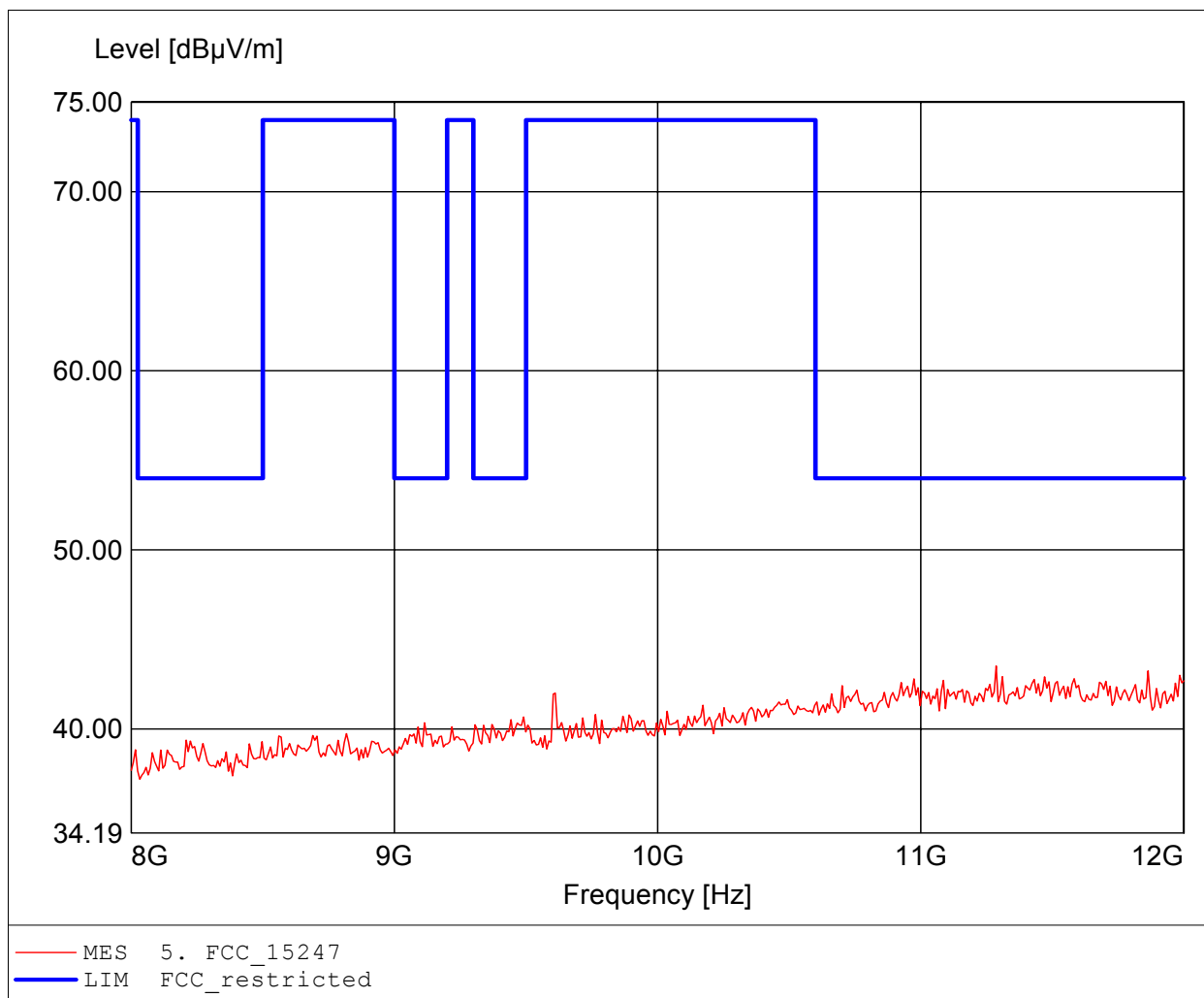

# Spurious emissions Field Strength

## FCC RULES PART 15, SUBPART C

Approval Holder: Polycom Denmark ApS / Ord.: G0M21006-3316  
EUT: DECT 6.0 Handset  
Model: 6040 / 2402 MHz  
Test Site / Operator: Eurofins Product Service GmbH / Mr. Handrik  
Test Condition: Temp.: 23°C / Unom.: 3.7 V DC  
Test Specification: according to §15.247, peak detector  
Comment 1: Dist.: 3m, Ant.: BBHA9120D, ampl.+HP.  
Comment 2: Freq: 14.475GHz, Emax: 46.20dBµV/m, RBW: 1MHz

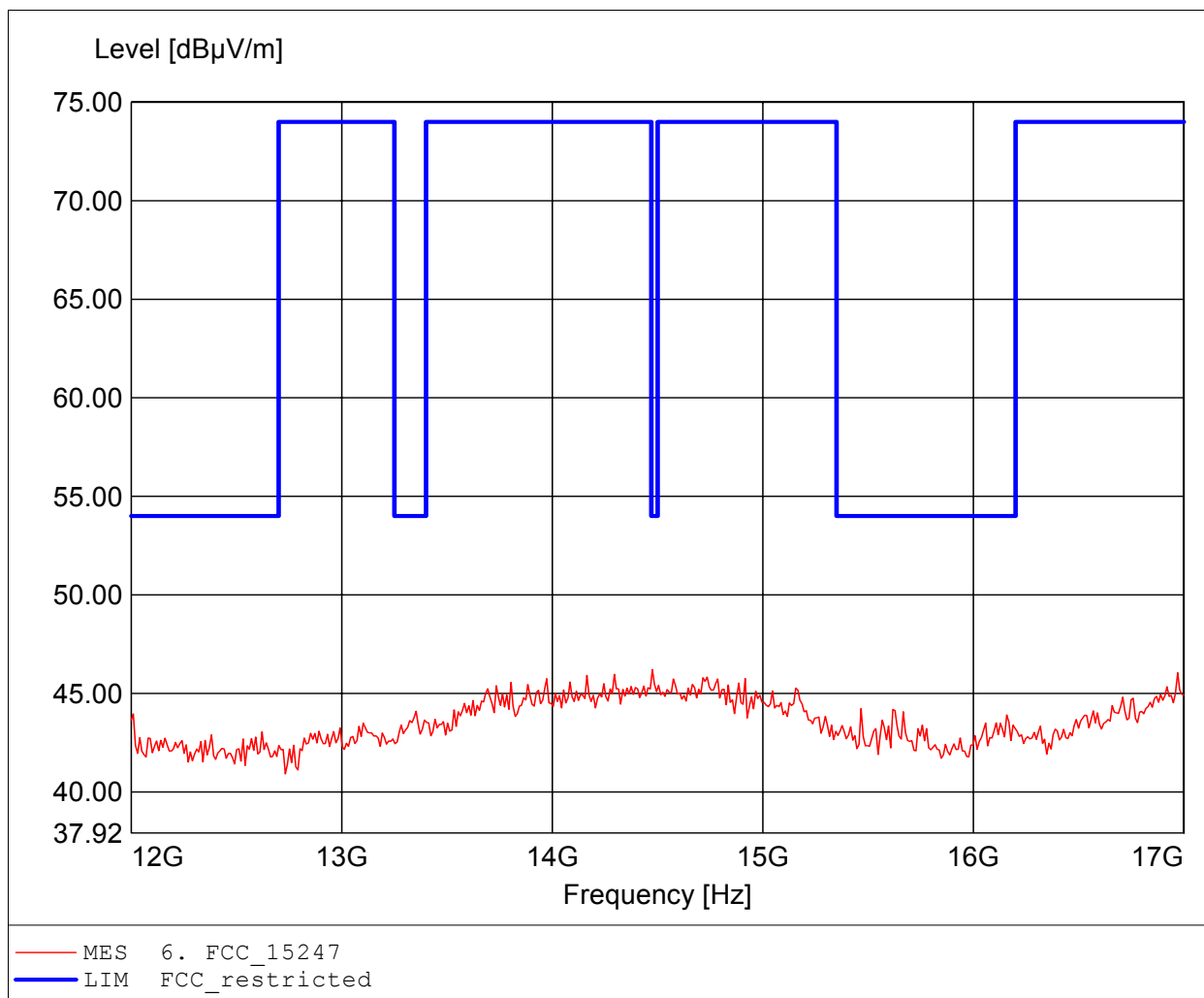

# Spurious emissions Field Strength

## FCC RULES PART 15, SUBPART C

Approval Holder: Polycom Denmark ApS / Ord.: G0M21006-3316  
EUT: DECT 6.0 Handset  
Model: 6040 / 2402 MHz  
Test Site / Operator: Eurofins Product Service GmbH / Mr. Handrik  
Test Condition: Temp.: 23°C / Unom.: 3.7 V DC  
Test Specification: according to §15.247, peak detector  
Comment 1: Dist.: 3m, Ant.: BBHA9120D, ampl.+HP.  
Comment 2: Freq: 14.255GHz, Emax: 45.57dBµV/m, RBW: 1MHz

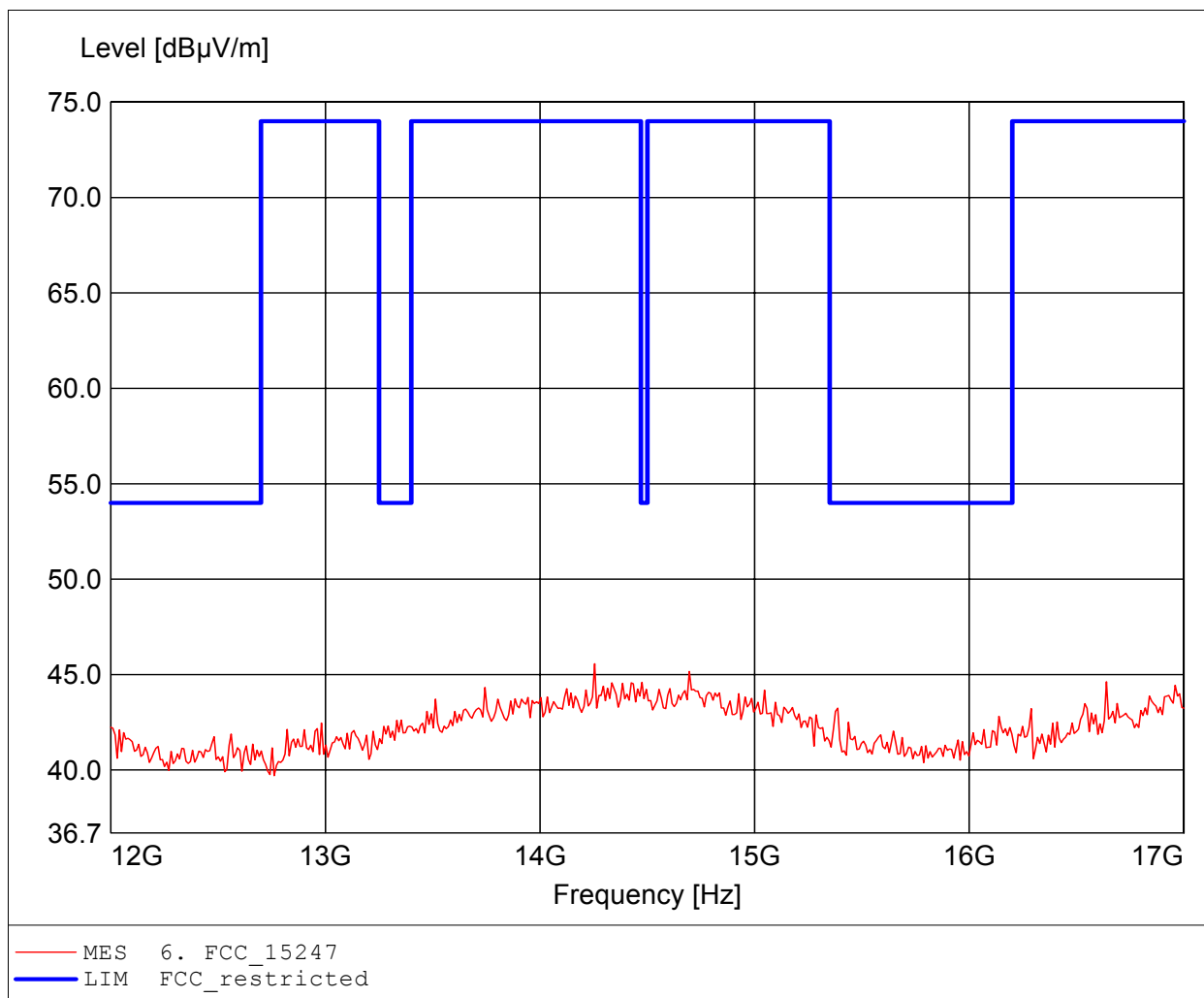

# Spurious emissions Field Strength

## FCC RULES PART 15, SUBPART C

Approval Holder: Polycom Denmark ApS / Ord.: G0M21006-3316  
EUT: DECT 6.0 Handset  
Model: 6040 / 2402 MHz  
Test Site / Operator: Eurofins Product Service GmbH / Mr. Handrik  
Test Condition: Temp.: 23°C / Unom.: 3.7 V DC  
Test Specification: according to §15.247, peak detector  
Comment 1: Dist.: 3m, Ant.: HL025, amplif.  
Comment 2: Freq: 24.539GHz, Emax: 50.79dBµV/m, RBW: 1MHz

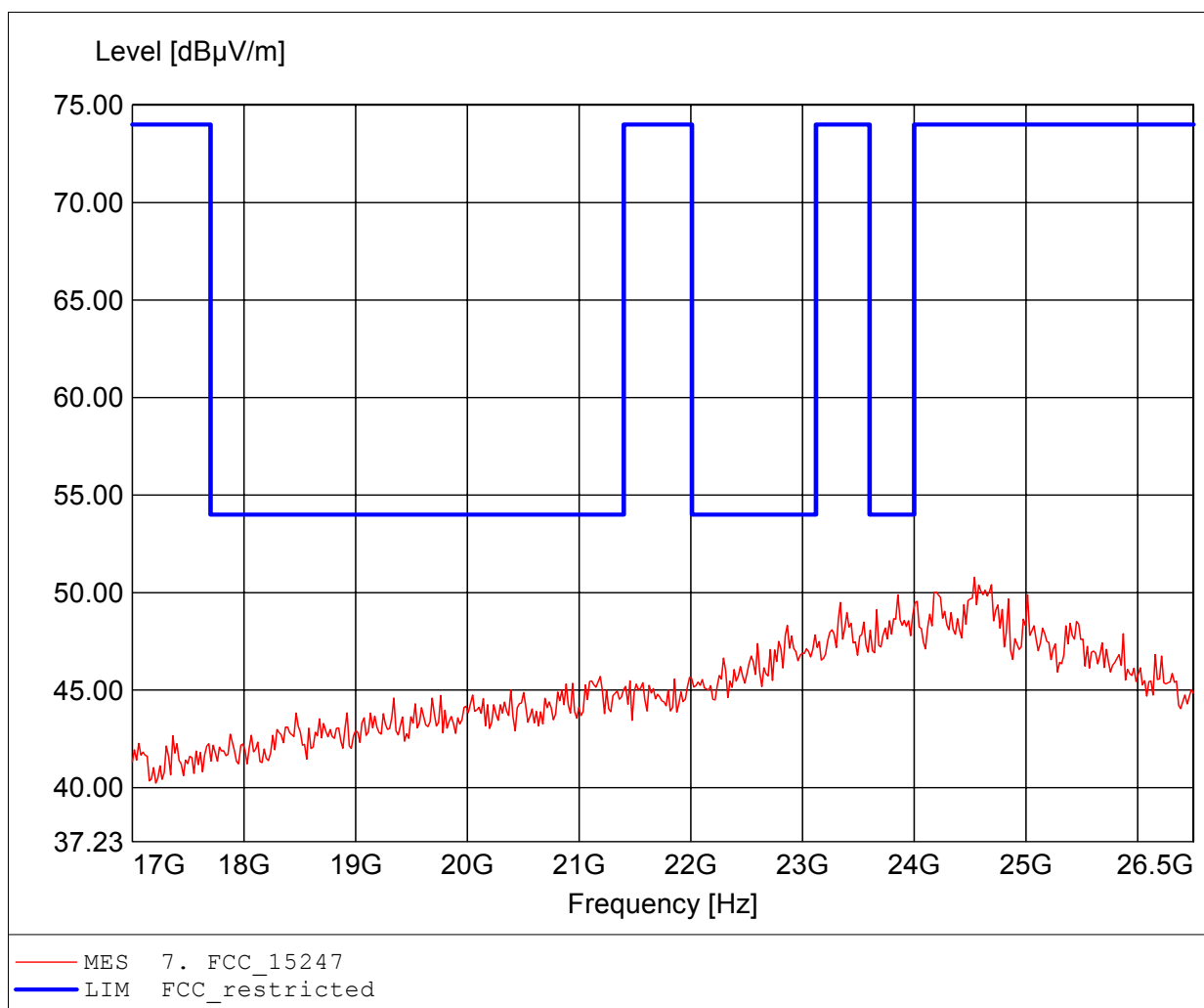

**Spurious emissions Field Strength**

**FCC RULES PART 15, SUBPART C**

Approval Holder: Polycom Denmark ApS / Ord.: G0M21006-3316  
EUT: DECT 6.0 Handset  
Model: 6040 / 2402 MHz  
Test Site / Operator: Eurofins Product Service GmbH / Mr. Handrik  
Test Condition: Temp.: 23°C / Unom.: 3.7 V DC  
Test Specification: according to §15.247, peak detector  
Comment 1: Dist.: 3m, Ant.: HL025, amplif.  
Comment 2: Freq: 24.234GHz, Emax: 51.28dBµV/m, RBW: 1MHz

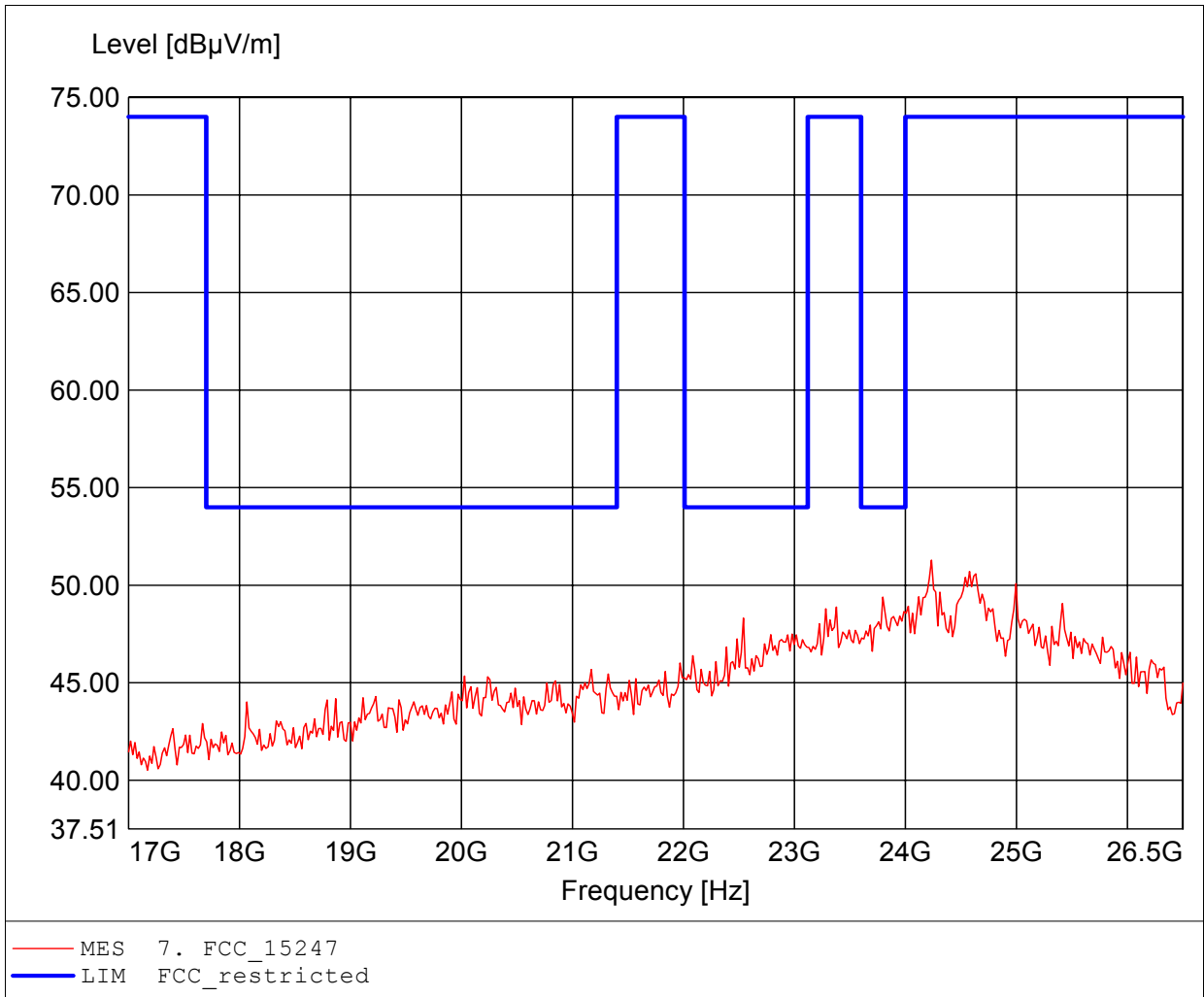

# Spurious emissions Field Strength

## FCC RULES PART 15, SUBPART C

Approval Holder: Polycom Denmark ApS / Ord.: G0M21006-3316  
EUT: DECT 6.0 Handset  
Model: 6040 / 2441 MHz  
Operator: Eurofins Product Service GmbH / Mr. Handrik  
Test Conditions: Tnom: 23°C / Unom: 3.7 V DC  
Test Specification: according to §15.247, peak detector  
Comment 1: Dist.: 3m, Ant.: H1 025, amplif.  
Comment 2: Freq: 3.963GHz, Emax: 42.70dBµV/m, RBW: 1MHz

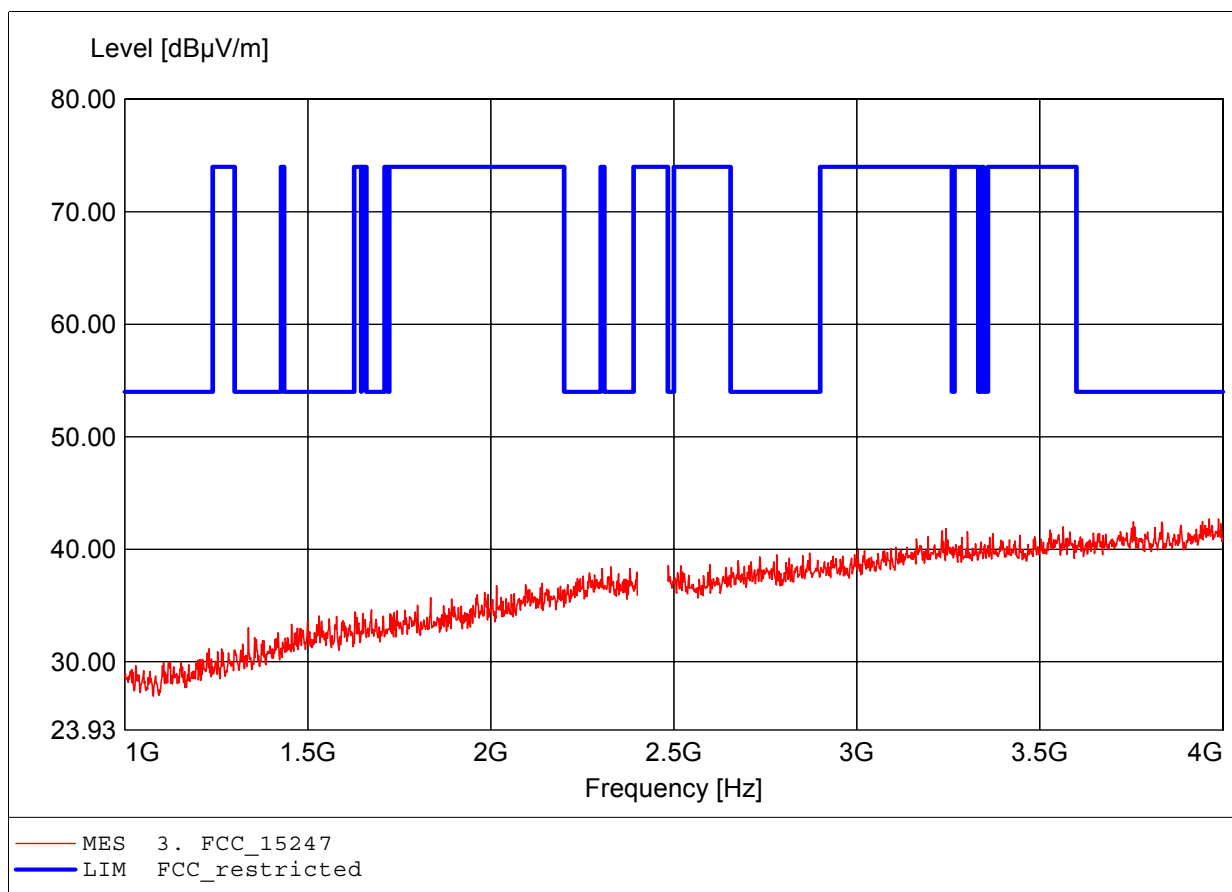

# Spurious emissions Field Strength

## FCC RULES PART 15, SUBPART C

Approval Holder: Polycom Denmark ApS / Ord.: G0M21006-3316  
EUT: DECT 6.0 Handset  
Model: 6040 / 2441 MHz  
Operator: Eurofins Product Service GmbH / Mr. Handrik  
Test Conditions: Tnom: 23°C / Unom: 3.7 V DC  
Test Specification: according to §15.247, peak detector  
Comment 1: Dist.: 3m, Ant.: H1 025, amplif.  
Comment 2: Freq: 3.946GHz, Emax: 42.88dBµV/m, RBW: 1MHz

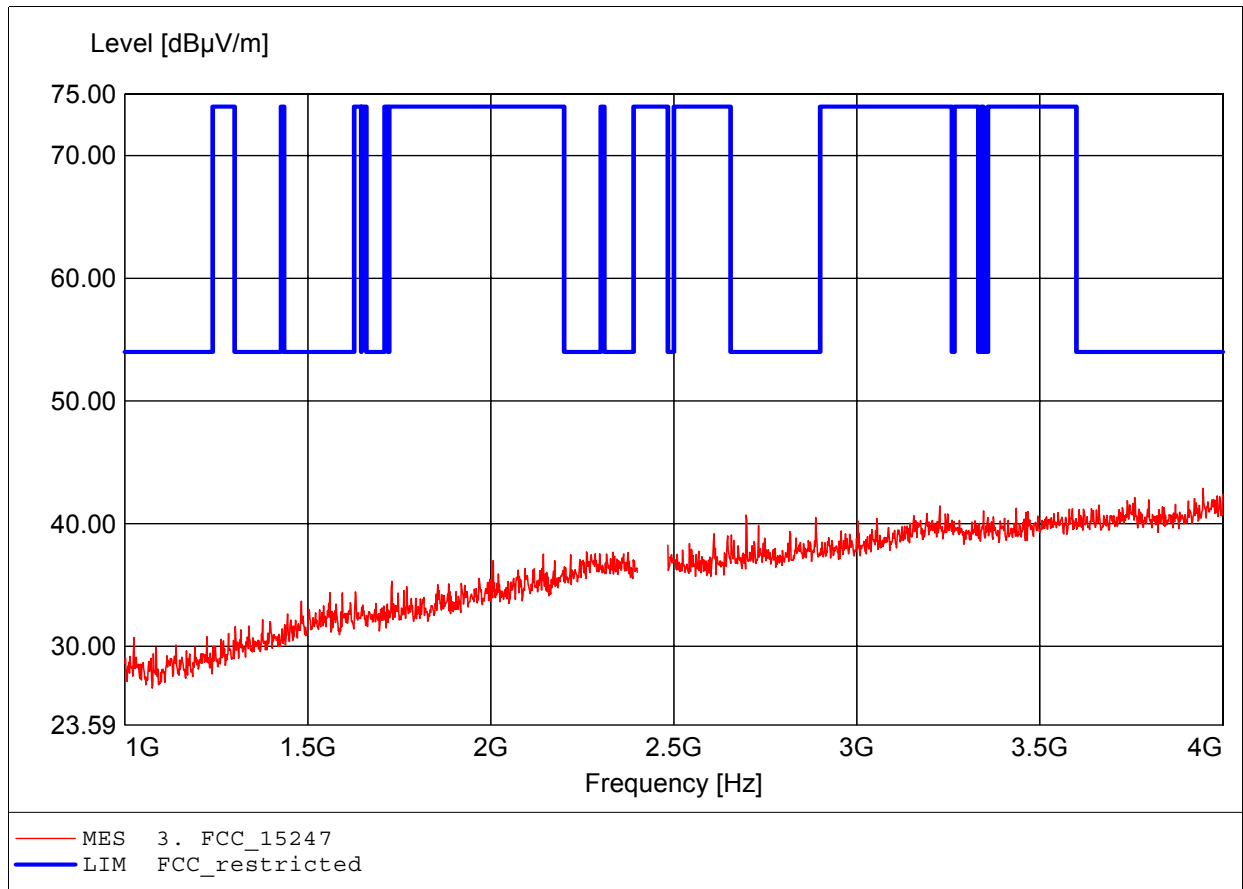

# Spurious emissions Field Strength

## FCC RULES PART 15, SUBPART C

Approval Holder: Polycom Denmark ApS / Ord.: G0M21006-3316  
EUT: DECT 6.0 Handset  
Model: 6040 / 2441 MHz  
Operator: Eurofins Product Service GmbH / Mr. Handrik  
Test Conditions: Tnom: 23°C / Unom: 3.7 V DC  
Test Specification: according to §15.247, peak detector  
Comment 1: Dist.: 3m, Ant.: H1 025, ampl.+HP.  
Comment 2: Freq: 7.956GHz, Emax: 47.94dBµV/m, RBW: 1MHz

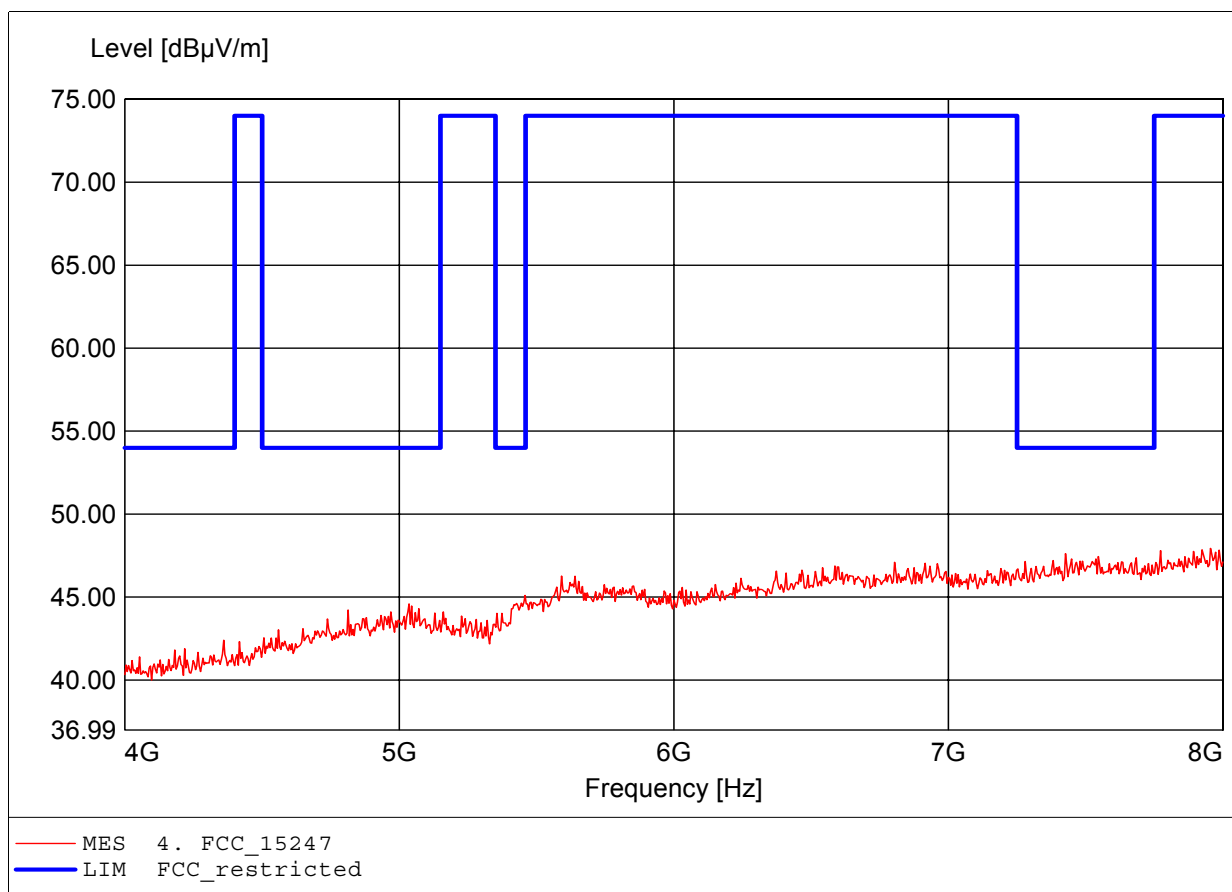



# Spurious emissions Field Strength

## FCC RULES PART 15, SUBPART C

Approval Holder: Polycom Denmark ApS / Ord.: G0M21006-3316  
EUT: DECT 6.0 Handset  
Model: 6040 / 2441 MHz  
Operator: Eurofins Product Service GmbH / Mr. Handrik  
Test Conditions: Tnom: 23°C / Unom: 3.7 V DC  
Test Specification: according to §15.247, peak detector  
Comment 1: Dist.: 3m, Ant.: H1 025, ampl.+HP.  
Comment 2: Freq: 7.987GHz, Emax: 47.58dBµV/m, RBW: 1MHz

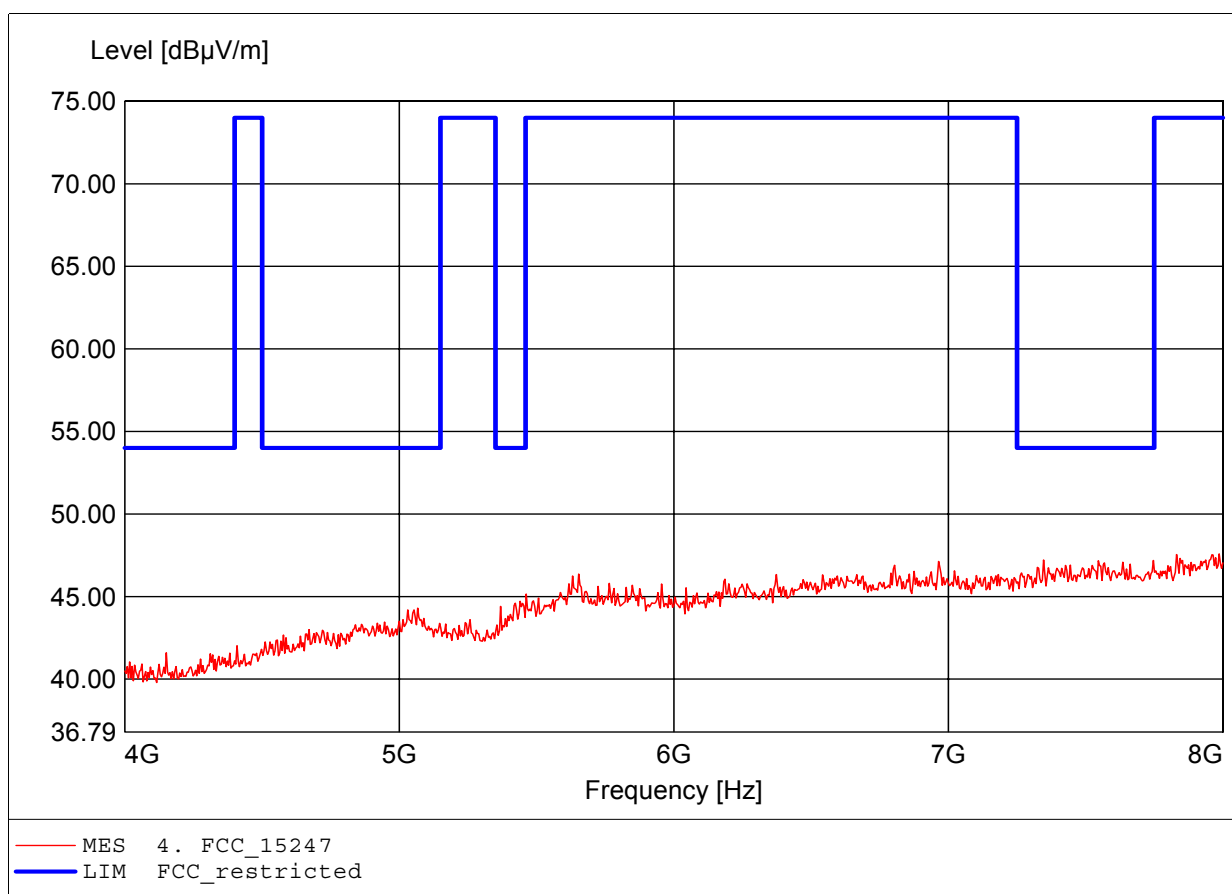

# Spurious emissions Field Strength

## FCC RULES PART 15, SUBPART C

Approval Holder: Polycom Denmark ApS / Ord.: G0M21006-3316  
EUT: DECT 6.0 Handset  
Model: 6040 / 2441 MHz  
Test Site / Operator: Eurofins Product Service GmbH / Mr. Handrik  
Test Condition: Temp.: 23°C / Unom.: 3.7 V DC  
Test Specification: according to §15.247, peak detector  
Comment 1: Dist.: 3m, Ant.: BBHA9120D, ampl.+HP.  
Comment 2: Freq: 11.968GHz, Emax: 43.41dBµV/m, RBW: 1MHz

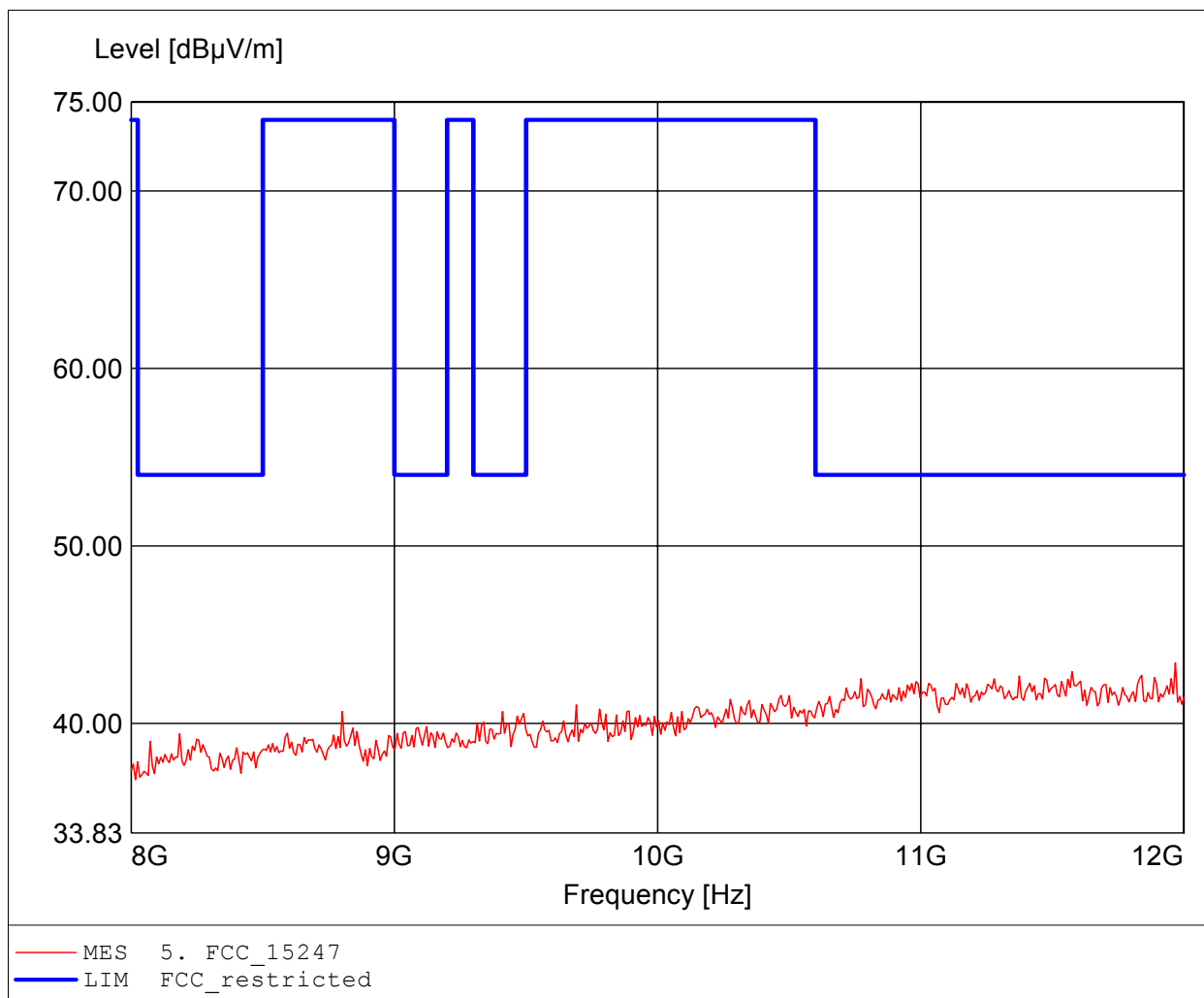

# Spurious emissions Field Strength

## FCC RULES PART 15, SUBPART C

Approval Holder: Polycom Denmark ApS / Ord.: G0M21006-3316  
EUT: DECT 6.0 Handset  
Model: 6040 / 2441 MHz  
Test Site / Operator: Eurofins Product Service GmbH / Mr. Handrik  
Test Condition: Temp.: 23°C / Unom.: 3.7 V DC  
Test Specification: according to §15.247, peak detector  
Comment 1: Dist.: 3m, Ant.: BBHA9120D, ampl.+HP.  
Comment 2: Freq: 10.990GHz, Emax: 43.07dBµV/m, RBW: 1MHz

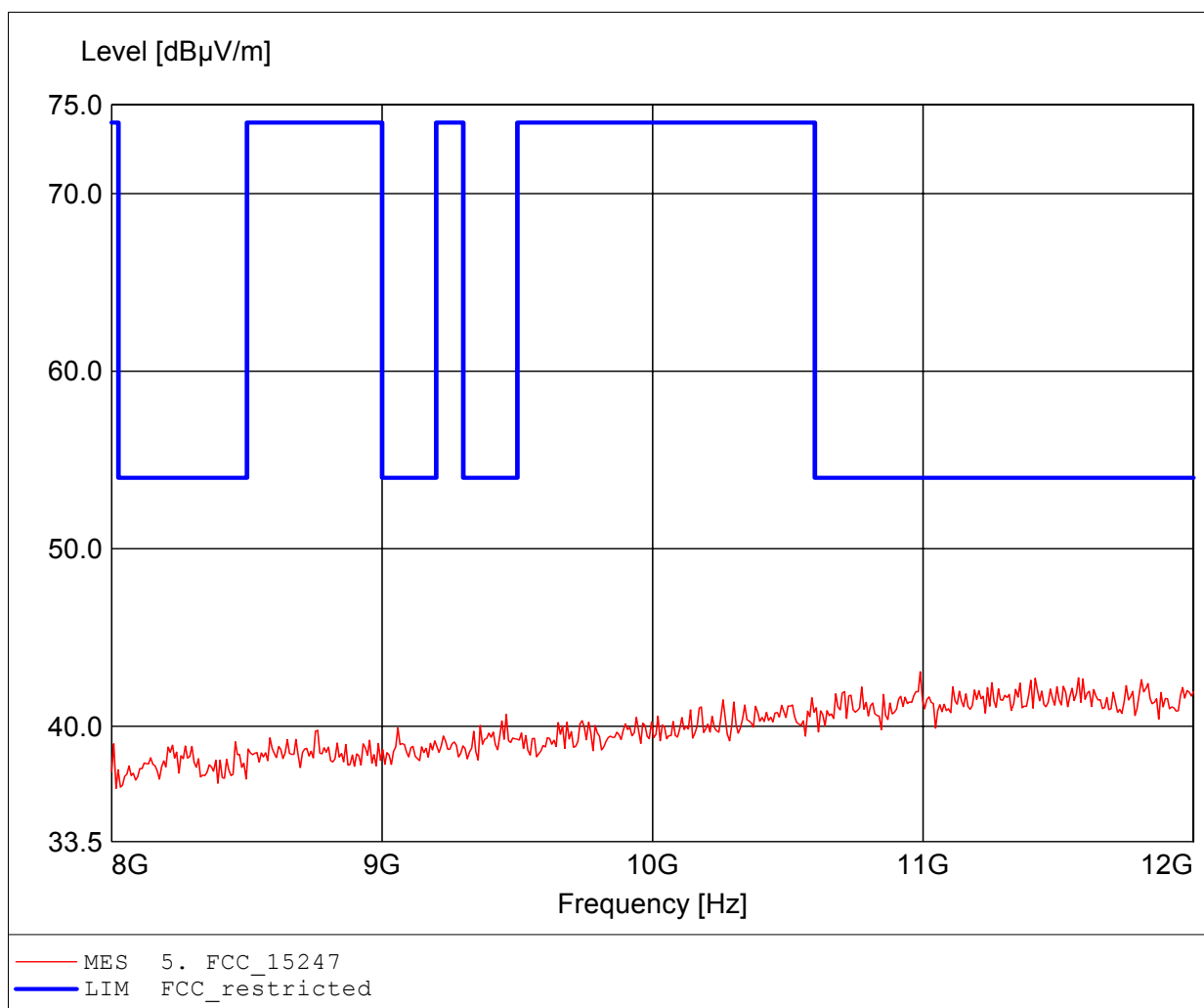

# Spurious emissions Field Strength

## FCC RULES PART 15, SUBPART C

Approval Holder: Polycom Denmark ApS / Ord.: GOM21006-3316  
EUT: DECT 6.0 Handset  
Model: 6040 / 2480 MHz  
Test Site / Operator: Eurofins Product Service GmbH / Mr. Handrik  
Test Condition: Temp.: 23°C / Unom.: 3.7 V DC  
Test Specification: according to §15.247, peak detector  
Comment 1: Dist.: 3m, Ant.: BBHA9120D, amplif.  
Comment 2: Freq: 3.796GHz, Emax: 43.14dBµV/m, RBW: 1MHz

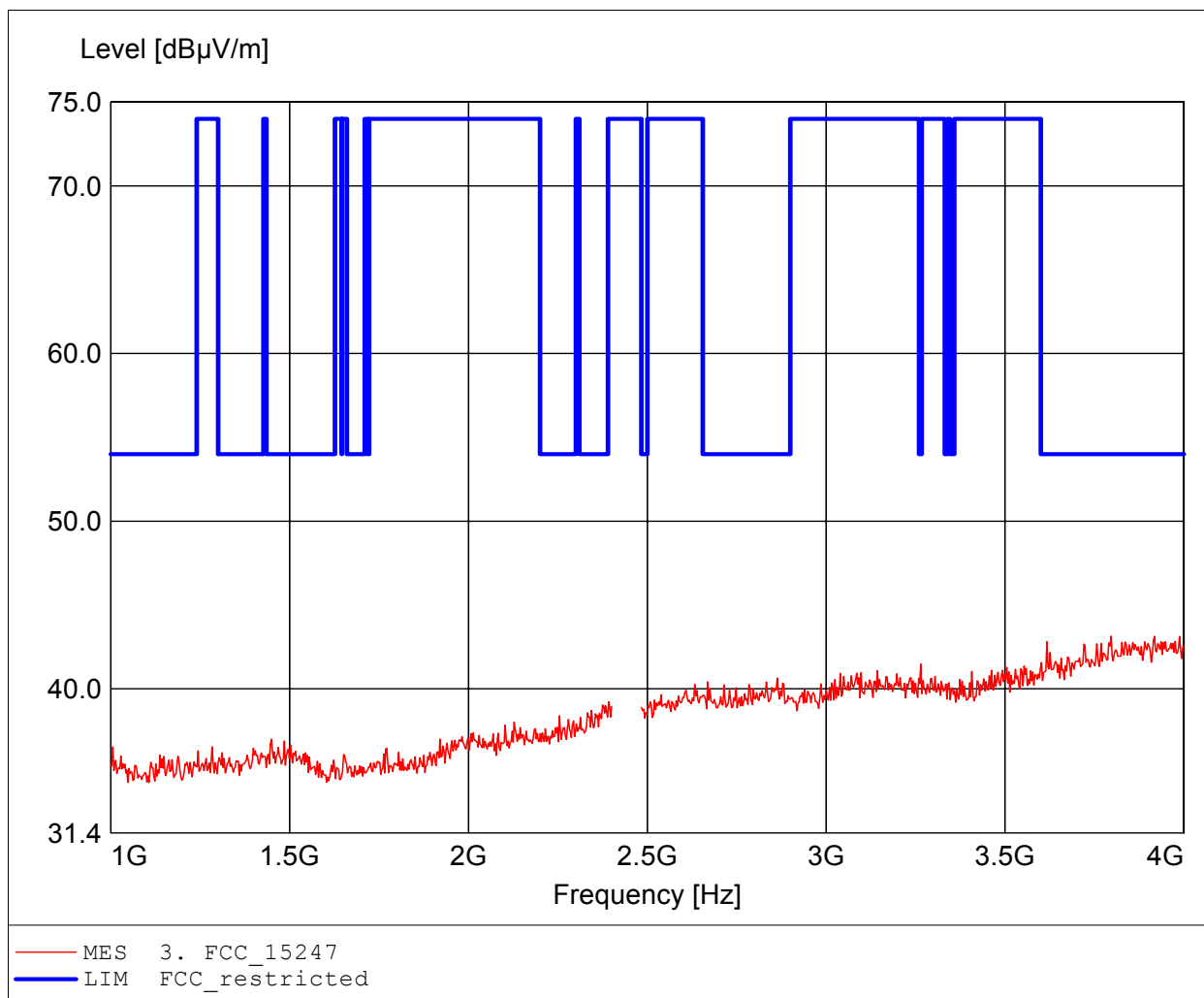

# Spurious emissions Field Strength

## FCC RULES PART 15, SUBPART C

Approval Holder: Polycom Denmark ApS / Ord.: G0M21006-3316  
EUT: DECT 6.0 Handset  
Model: 6040 / 2480 MHz  
Operator: Eurofins Product Service GmbH / Mr. Handrik  
Test Conditions: Tnom: 23°C / Unom: 3.7 V DC  
Test Specification: according to §15.247, peak detector  
Comment 1: Dist.: 3m, Ant.: H1 025, amplif.  
Comment 2: Freq: 3.944GHz, Emax: 43.13dBµV/m, RBW: 1MHz

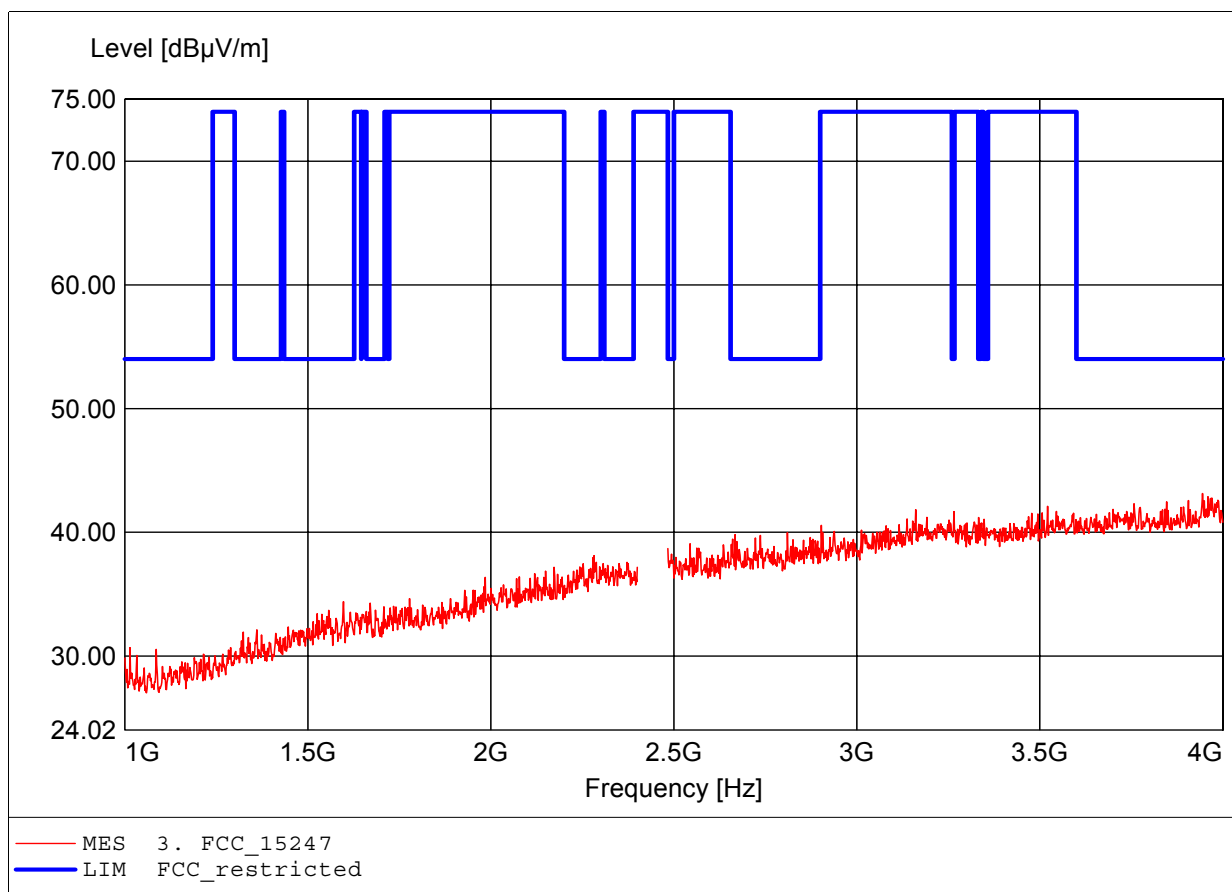

# Spurious emissions Field Strength

## FCC RULES PART 15, SUBPART C

Approval Holder: Polycom Denmark ApS / Ord.: G0M21006-3316  
EUT: DECT 6.0 Handset  
Model: 6040 / 2480 MHz  
Test Site / Operator: Eurofins Product Service GmbH / Mr. Handrik  
Test Condition: Temp.: 23°C / Unom.: 3.7 V DC  
Test Specification: according to §15.247, peak detector  
Comment 1: Dist.: 3m, Ant.: BBHA9120D, ampl.+HP.  
Comment 2: Freq: 7.904GHz, Emax: 50.07dBµV/m, RBW: 1MHz

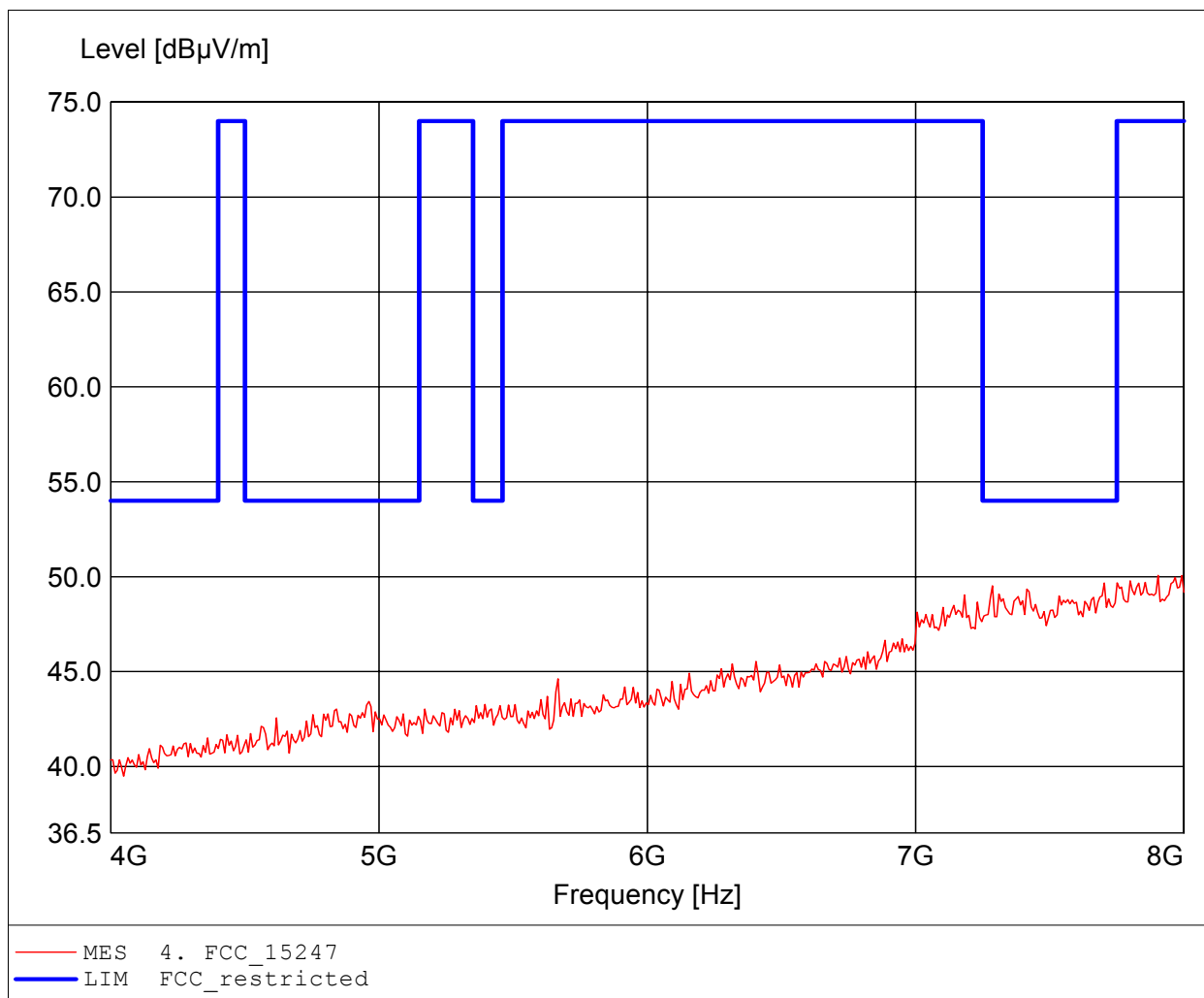

# Spurious emissions Field Strength

## FCC RULES PART 15, SUBPART C

Approval Holder: Polycom Denmark ApS / Ord.: G0M21006-3316  
EUT: DECT 6.0 Handset  
Model: 6040 / 2480 MHz  
Operator: Eurofins Product Service GmbH / Mr. Handrik  
Test Conditions: Tnom: 23°C / Unom: 3.7 V DC  
Test Specification: according to §15.247, peak detector  
Comment 1: Dist.: 3m, Ant.: H1 025, ampl.+HP.  
Comment 2: Freq: 7.956GHz, Emax: 48.22dBµV/m, RBW: 1MHz

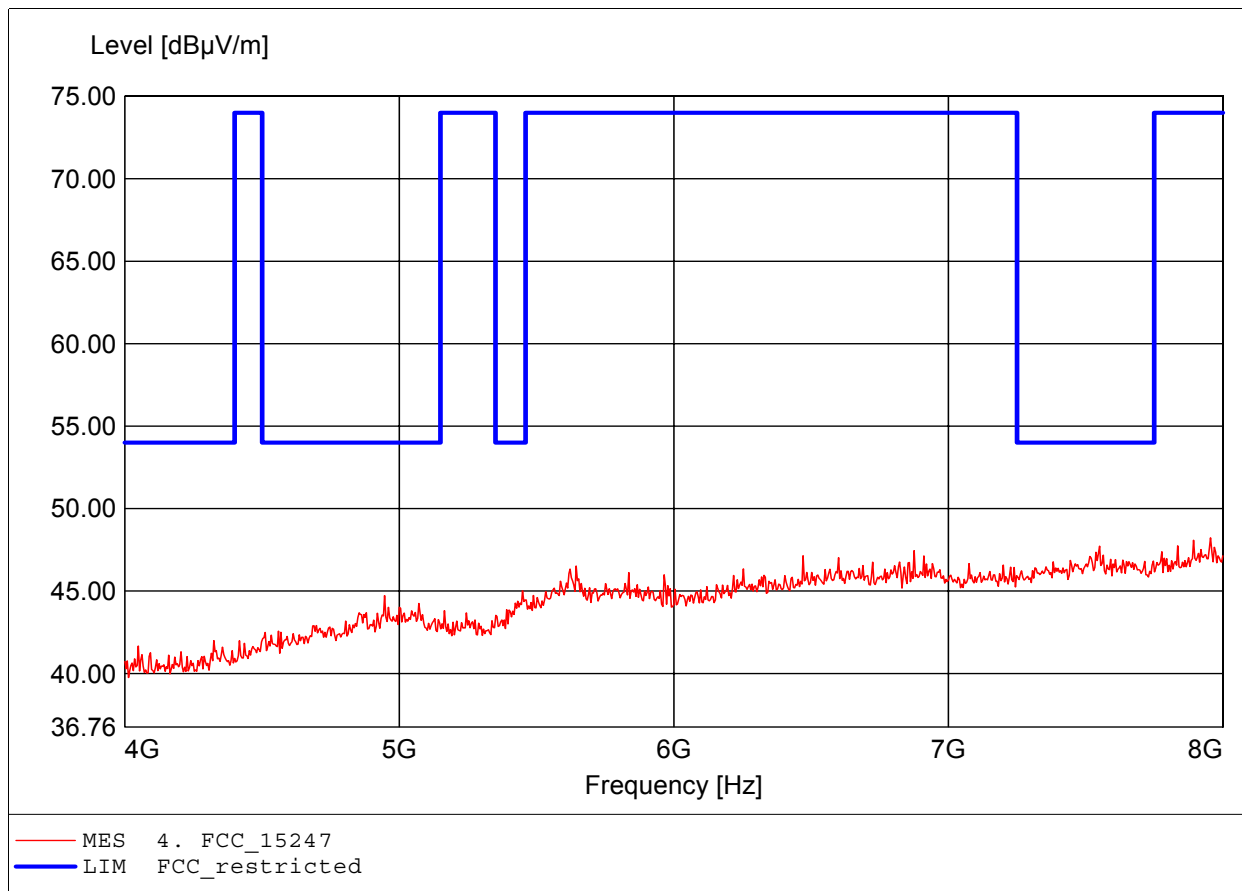

# Spurious emissions Field Strength

## FCC RULES PART 15, SUBPART C

Approval Holder: Polycom Denmark ApS / Ord.: G0M21006-3316  
EUT: DECT 6.0 Handset  
Model: 6040 / 2480 MHz  
Test Site / Operator: Eurofins Product Service GmbH / Mr. Handrik  
Test Condition: Temp.: 23°C / Unom.: 3.7 V DC  
Test Specification: according to §15.247, peak detector  
Comment 1: Dist.: 3m, Ant.: BBHA9120D, ampl.+HP.  
Comment 2: Freq: 11.311GHz, Emax: 43.46dBµV/m, RBW: 1MHz

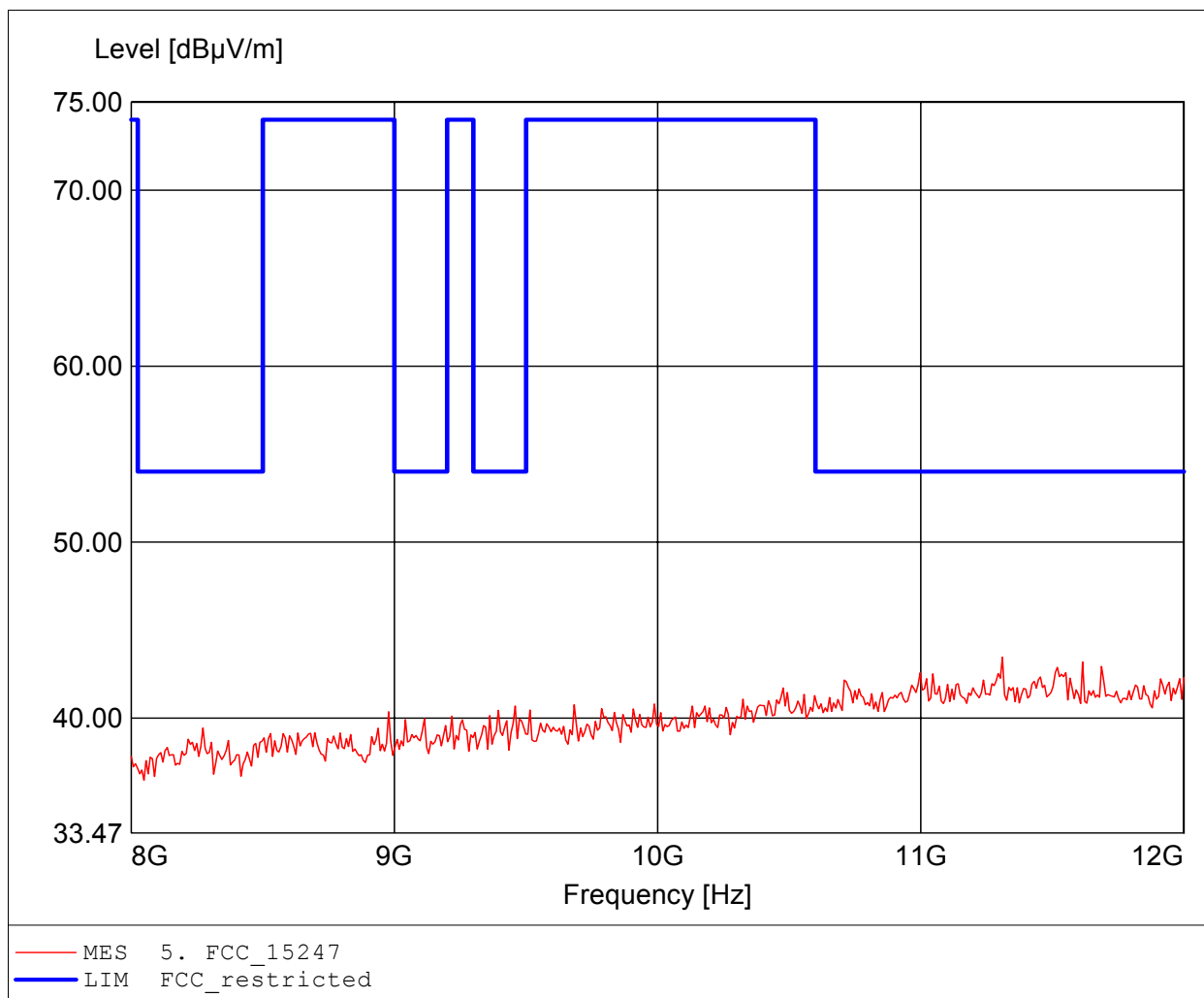



# Spurious emissions Field Strength

## FCC RULES PART 15, SUBPART C

Approval Holder: Polycom Denmark ApS / Ord.: G0M21006-3316  
EUT: DECT 6.0 Handset  
Model: 6040 / 2480 MHz  
Test Site / Operator: Eurofins Product Service GmbH / Mr. Handrik  
Test Condition: Temp.: 23°C / Unom.: 3.7 V DC  
Test Specification: according to §15.247, peak detector  
Comment 1: Dist.: 3m, Ant.: BBHA9120D, ampl.+HP.  
Comment 2: Freq: 11.752GHz, Emax: 43.19dBµV/m, RBW: 1MHz

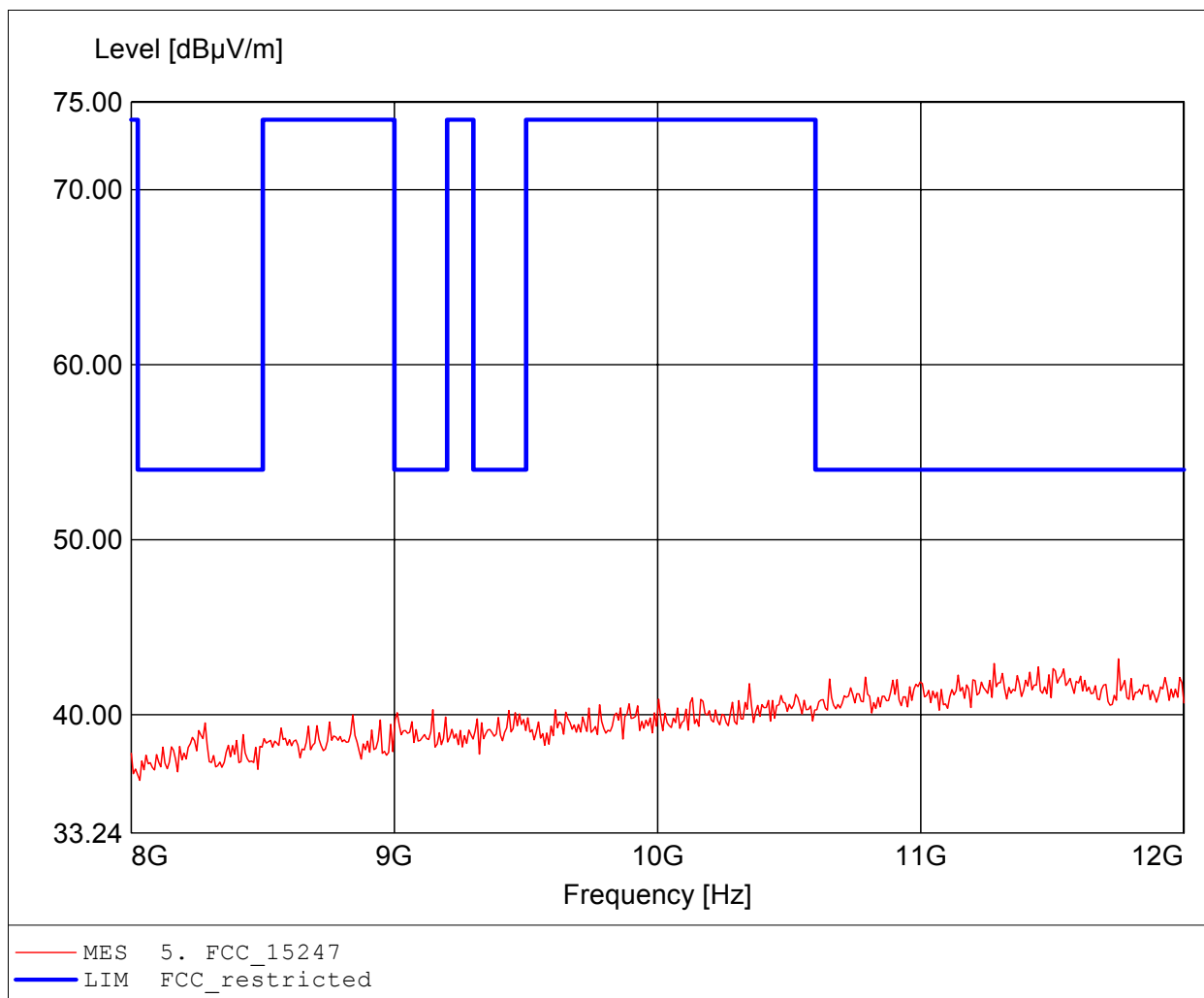

## **Annex K Receiver radiated spurious emissions**

**Field Strength under normal conditions**

**Standards Industry Canada, RSS-GEN**

Approval Holder: Polycom Denmark ApS  
EUT: DECT 6.0 Handset  
Model: 6040  
Test Site / Operator: Eurofins Product Service GmbH / Mr. Handrik  
Test Condition: Temp.: 23°C / Unom.: 3.7 V DC  
Test Specification: Freq.: 2441 MHz  
Comment 1: Dist.: 3m, Ant.: HK 116  
Comment 2: Freq:194.549MHz Emax:33.55dBuV/m RBW: 100 kHz

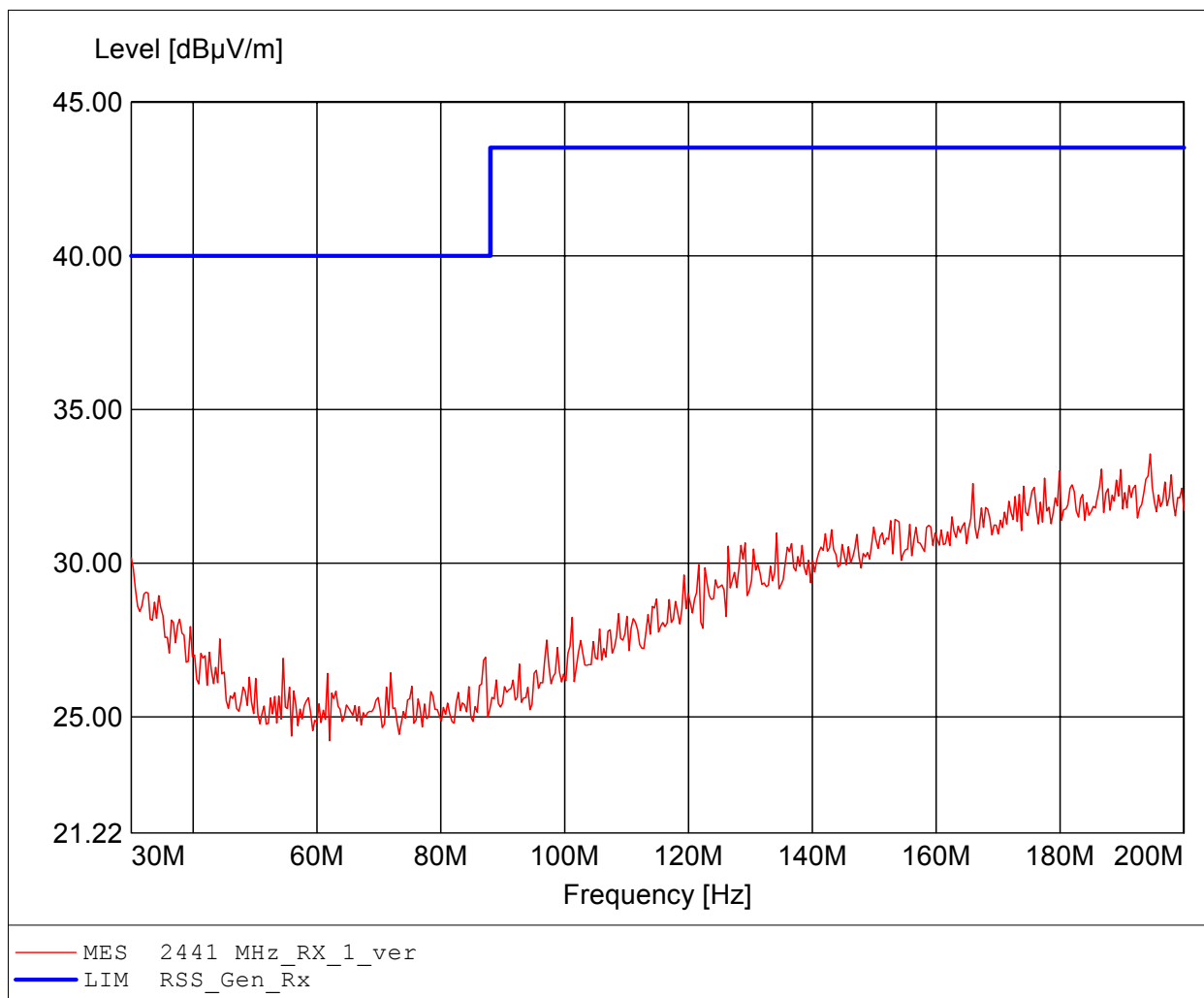

**Field Strength under normal conditions**

**Standards Industry Canada, RSS-GEN**

Approval Holder: Polycom Denmark ApS  
EUT: DECT 6.0 Handset  
Model: 6040  
Test Site / Operator: Eurofins Product Service GmbH / Mr. Handrik  
Test Condition: Temp.: 23°C / Unom.: 3.7 V DC  
Test Specification: Freq.: 2441 MHz  
Comment 1: Dist.: 3m, Ant.: HK 116  
Comment 2: Freq:190.461MHz Emax:33.41dBuV/m RBW: 100 kHz

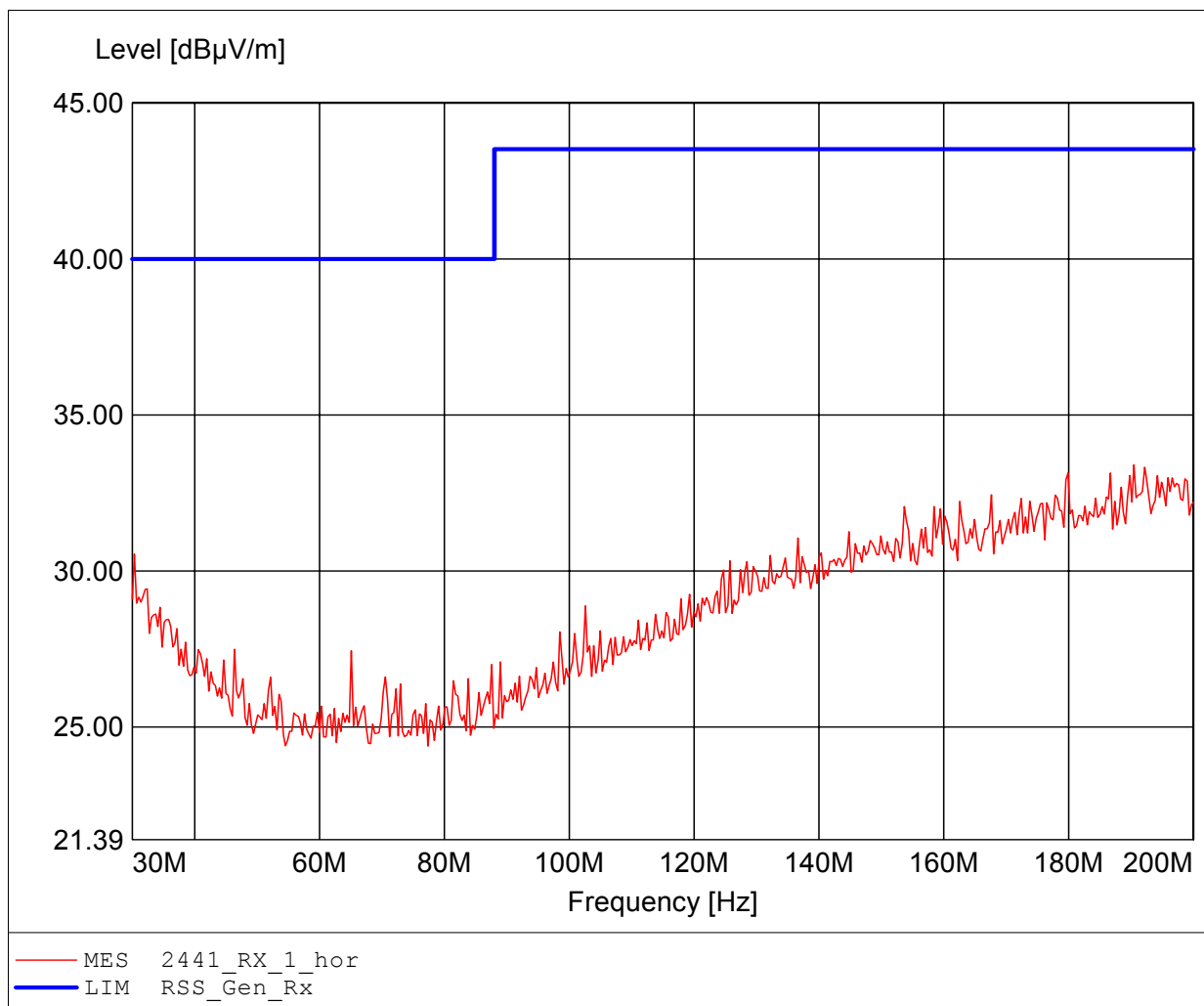

**Field Strength under normal conditions**

**Standards Industry Canada, RSS-GEN**

Approval Holder: Polycom Denmark ApS  
EUT: DECT 6.0 Handset  
Model: 6040  
Test Site / Operator: Eurofins Product Service GmbH / Mr. Handrik  
Test Condition: Temp.: 23°C / Unom.: 3.7 V DC  
Test Specification: Freq.: 2441 MHz  
Comment 1: Dist.: 3m, Ant.: HL 223, ampl.  
Comment 2: Freq:809.218MHz Emax:28.06dBuV/m RBW: 100 kHz

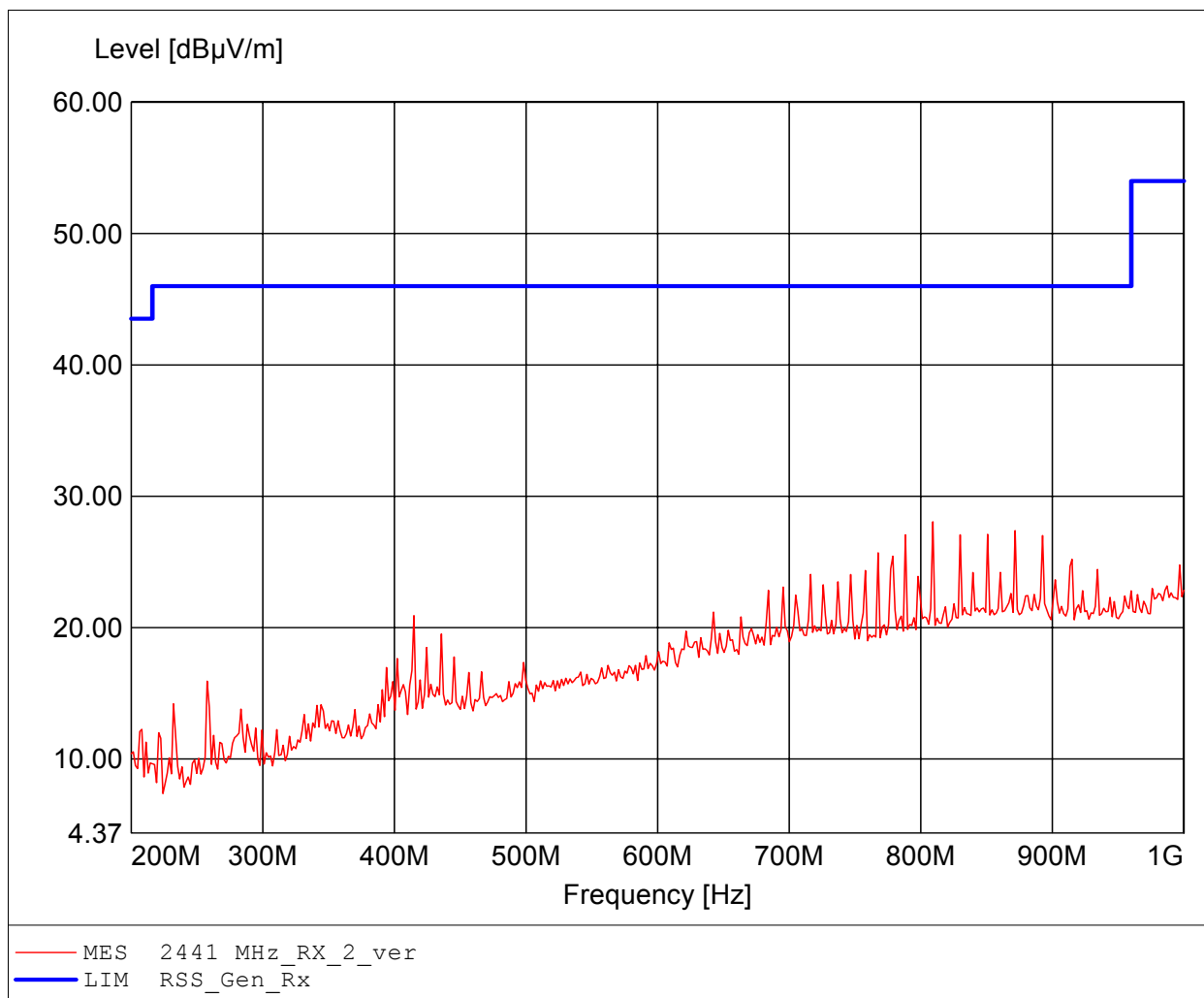

**Field Strength under normal conditions**

**Standards Industry Canada, RSS-GEN**

Approval Holder: Polycom Denmark ApS  
EUT: DECT 6.0 Handset  
Model: 6040  
Test Site / Operator: Eurofins Product Service GmbH / Mr. Handrik  
Test Condition: Temp.: 23°C / Unom.: 3.7 V DC  
Test Specification: Freq.: 2441 MHz  
Comment 1: Dist.: 3m, Ant.: HL 223, ampl.  
Comment 2: Freq:897.395MHz Emax:25.53dBuV/m RBW: 100 kHz

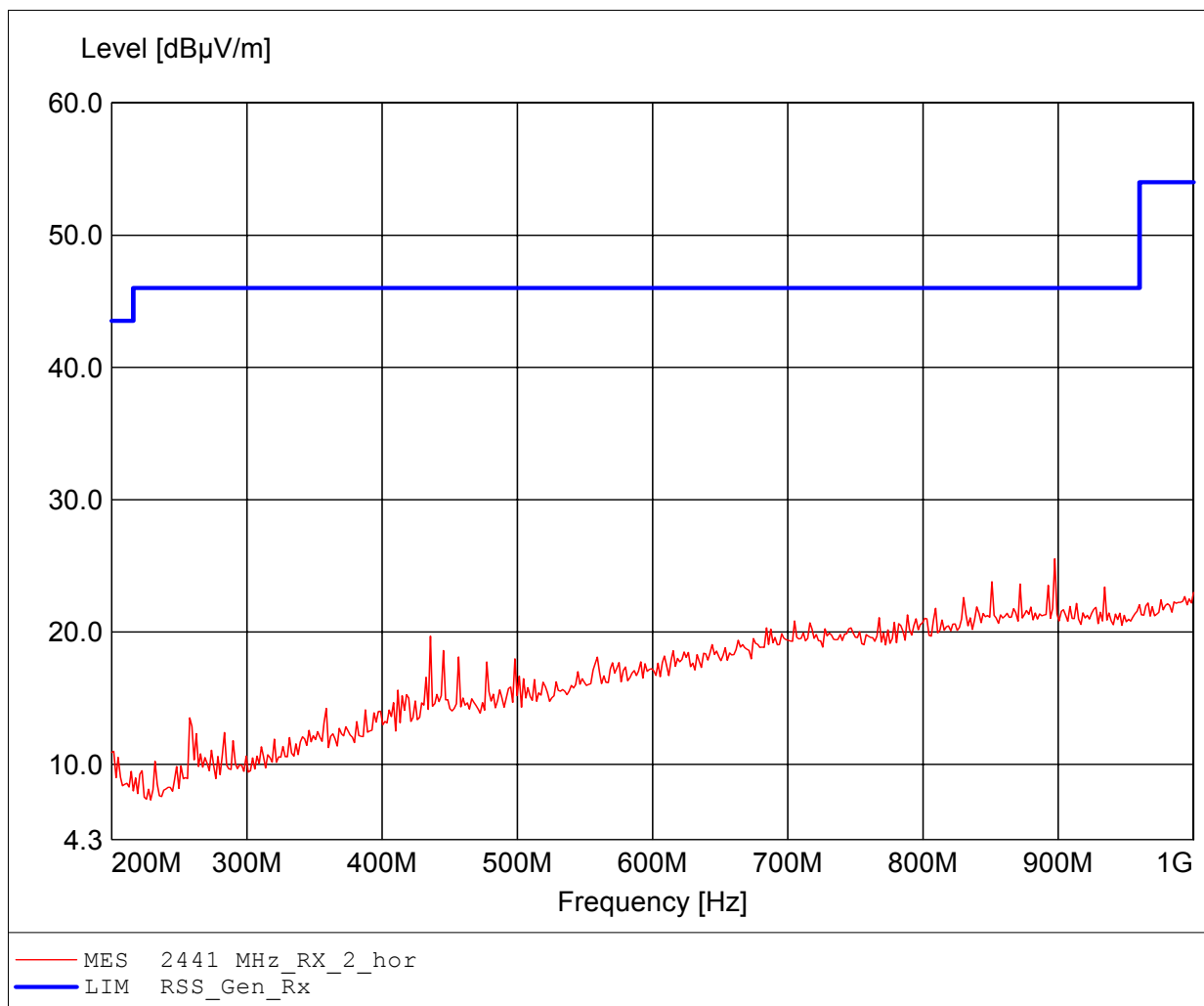

**Field Strength under normal conditions**

**Standards Industry Canada, RSS-GEN**

Approval Holder: Polycom Denmark ApS  
EUT: DECT 6.0 Handset  
Model: 6040  
Test Site / Operator: Eurofins Product Service GmbH / Mr. Handrik  
Test Condition: Temp.: 23°C / Unom.: 3.7 V DC  
Test Specification: Freq.: 2441 MHz  
Comment 1: Dist.: 3m, Ant.: HL025, ampl.  
Comment 2: Freq:3.934GHz Emax:43.18dBµV/m RBW: 1 MHz

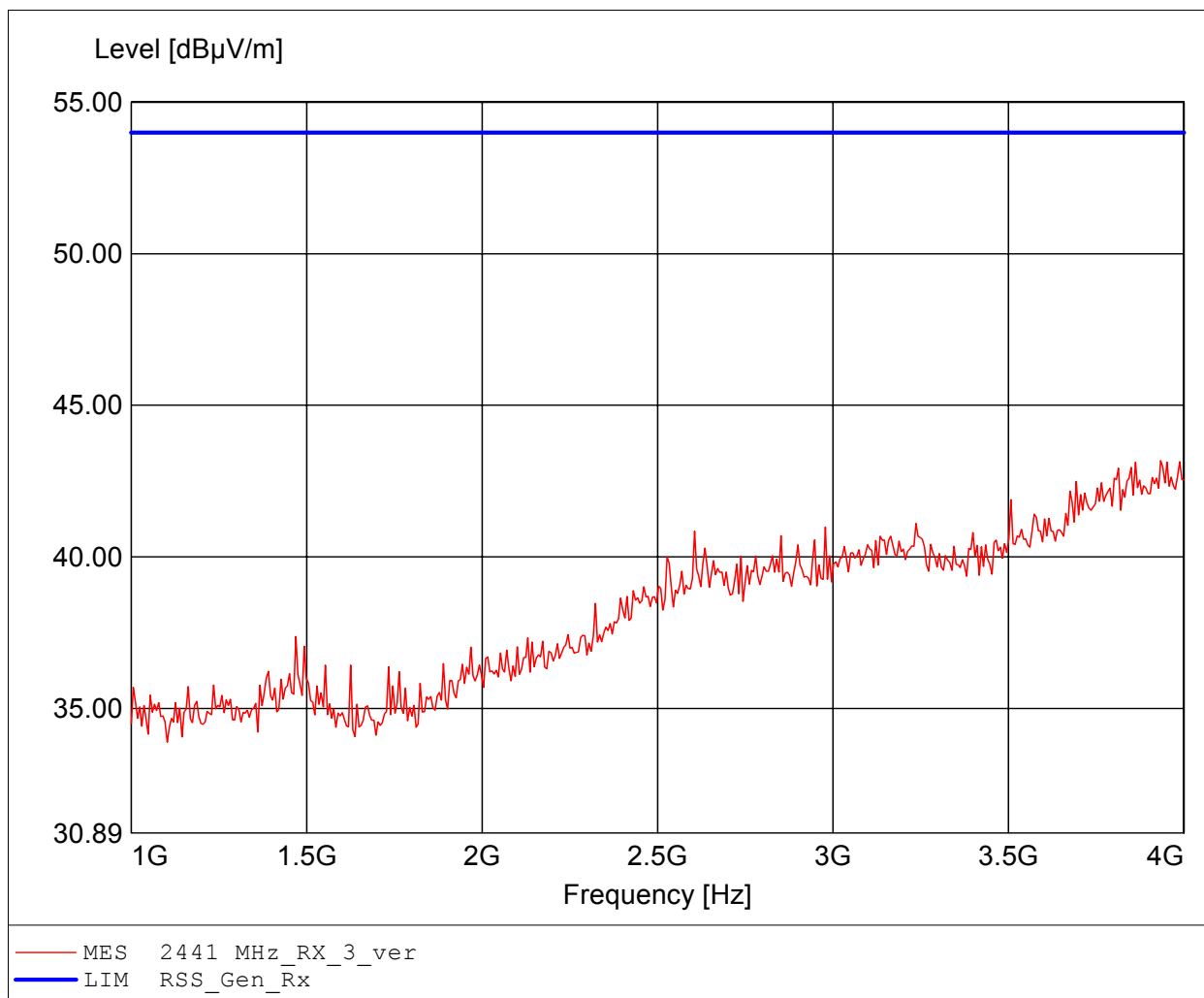

**Field Strength under normal conditions**

**Standards Industry Canada, RSS-GEN**

Approval Holder: Polycom Denmark ApS  
EUT: DECT 6.0 Handset  
Model: 6040  
Test Site / Operator: Eurofins Product Service GmbH / Mr. Handrik  
Test Condition: Temp.: 23°C / Unom.: 3.7 V DC  
Test Specification: Freq.: 2441 MHz  
Comment 1: Dist.: 3m, Ant.: HL025, ampl.  
Comment 2: Freq:2.954GHz Emax:43.25dBµV/m RBW: 1 MHz

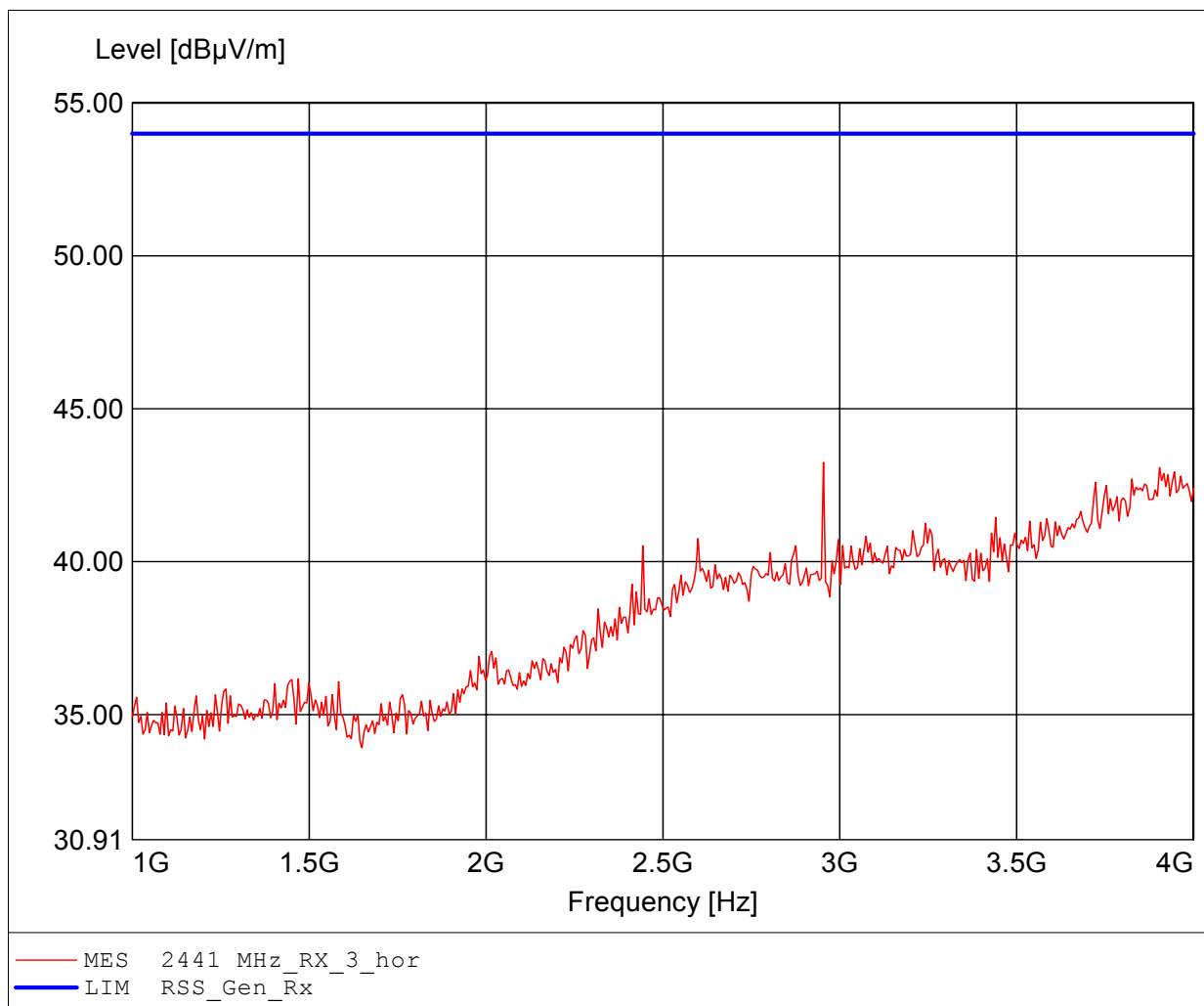



**Field Strength under normal conditions**

**Standards Industry Canada, RSS-GEN**

Approval Holder: Polycom Denmark ApS  
EUT: DECT 6.0 Handset  
Model: 6040  
Test Site / Operator: Eurofins Product Service GmbH / Mr. Handrik  
Test Condition: Temp.: 23°C / Unom.: 3.7 V DC  
Test Specification: Freq.: 2441 MHz  
Comment 1: Dist.: 3m, Ant.: HL025, ampl.  
Comment 2: Freq:7.848GHz Emax:49.89dBuV/m RBW: 1 MHz

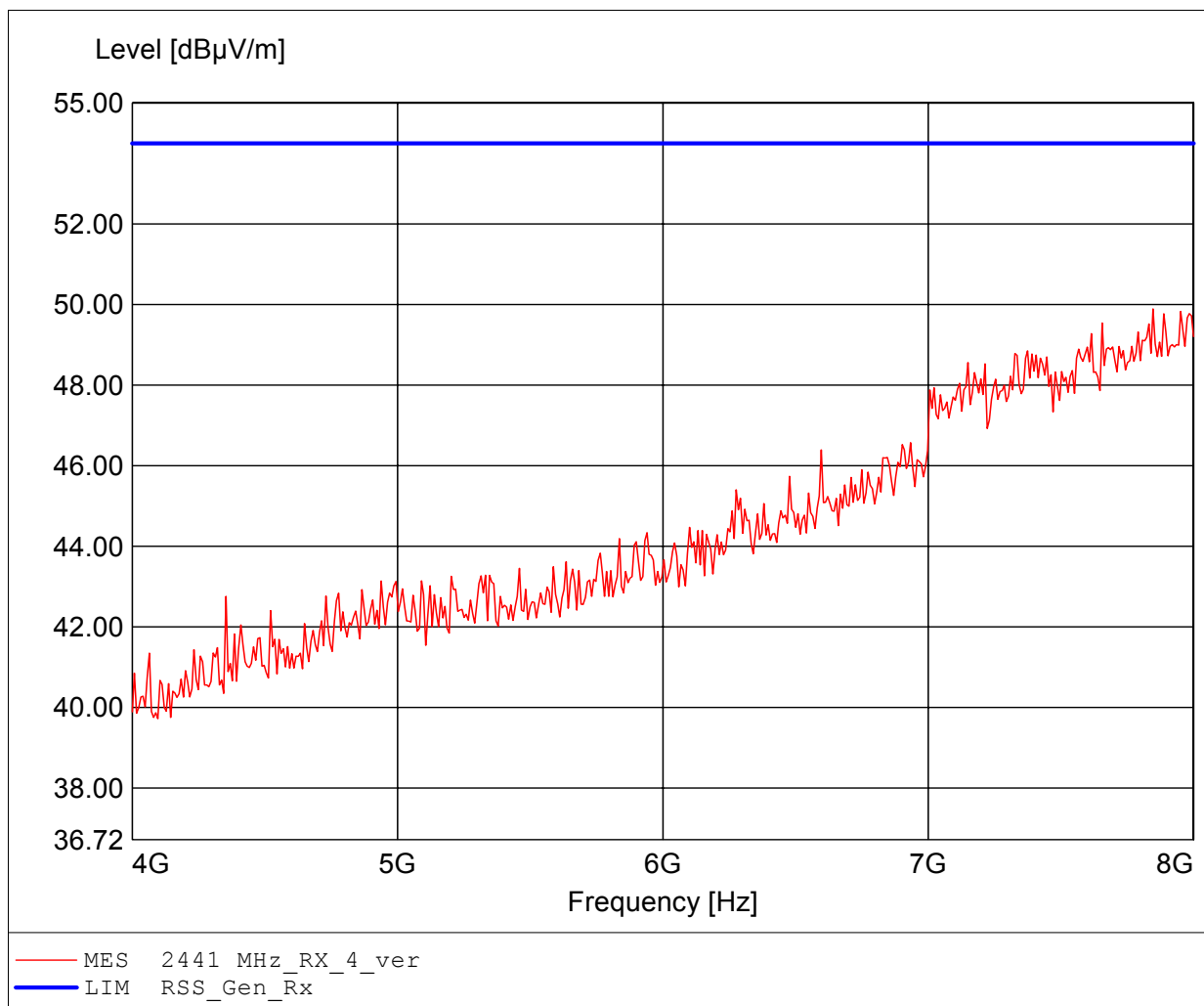

**Field Strength under normal conditions**

**Standards Industry Canada, RSS-GEN**

Approval Holder: Polycom Denmark ApS  
EUT: DECT 6.0 Handset  
Model: 6040  
Test Site / Operator: Eurofins Product Service GmbH / Mr. Handrik  
Test Condition: Temp.: 23°C / Unom.: 3.7 V DC  
Test Specification: Freq.: 2441 MHz  
Comment 1: Dist.: 3m, Ant.: HL025, ampl.  
Comment 2: Freq:7.976GHz Emax:50.37dBµV/m RBW: 1 MHz

