



RADIO TEST REPORT

Report No.: STS2002171W27

Issued for

Winmate Inc.

9F, No.111-6, Shing-De Rd., San-Chung Dist., New Taipei
City, 24158, Taiwan, R.O.C

Product Name:	Rugged Tablet PC
Brand Name:	Winmate
Model Name:	M133WK
Series Model:	M133WK-DW, M133XXXXXXXXXXXX (Where X can be A-Z,a-z ,0-9, "-", Blank or Slash)
FCC ID:	PX9M133WK001
Test Standard:	FCC Part 15.247 RSS-247 Issue 2, February 2017

Any reproduction of this document must be done in full. No single part of this document may be reproduced without permission from STS, All Test Data Presented in this report is only applicable to presented Test sample.

Shenzhen STS Test Services Co., Ltd.
A 1/F, Building B, Zhuoke Science Park, No.190 Chongqing Road, HepingShequ,
Fuyong Sub-District, Bao'an District, Shenzhen, Guang Dong, China
TEL: +86-755 3688 6288 FAX: +86-755 3688 6277 E-mail: sts@stsapp.com





TEST RESULT CERTIFICATION

Applicant's Name..... : Winmate Inc.
Address : 9F, No.111-6, Shing-De Rd., San-Chung Dist., New Taipei City, 24158, Taiwan, R.O.C

Manufacture's Name..... : Winmate Inc.
Address : 9F, No.111-6, Shing-De Rd., San-Chung Dist., New Taipei City, 24158, Taiwan, R.O.C

Product Description

Product Name..... : Rugged Tablet PC
Brand Name : Winmate
Model Name : M133WK
Series Model..... : M133WK-DW, M133XXXXXXXXXXXX
(Where X can be A-Z,a-z ,0-9, "-", Blank or Slash)
FCC Part15.407

Test Standards..... : RSS-247 Issue 2, February 2017
RSS-Gen Issue 5 ,March 2019

Test Procedure..... ANSI C63.10-2013

This device described above has been tested by STS, the test results show that the equipment under test (EUT) is in compliance with the FCC/IC requirements. And it is applicable only to the tested sample identified in the report.

This report shall not be reproduced except in full, without the written approval of STS, this document only be altered or revised by STS, personal only, and shall be noted in the revision of the document.

Date of Test..... :

Date of receipt of test item : 24 Feb. 2020
Date (s) of performance of tests : 24 Feb. 2020 ~ 28 Apr. 2020
Date of Issue..... : 29 Apr. 2020
Test Result..... : **Pass**

Testing Engineer :

(Chris Chen)

Technical Manager :

(Sean she)

Authorized Signatory :

(Vita Li)

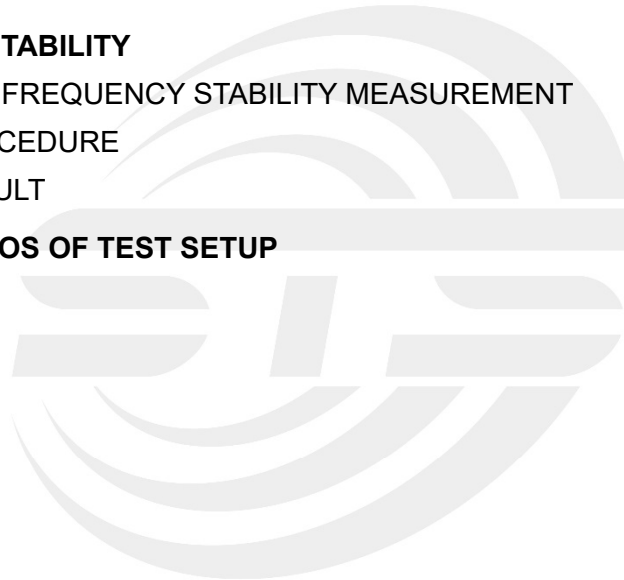



Table of Contents	Page
1 . SUMMARY OF TEST RESULTS	6
1.1 TEST FACTORY	7
1.2 MEASUREMENT UNCERTAINTY	7
2 . GENERAL INFORMATION	8
2.1 GENERAL DESCRIPTION OF THE EUT	8
2.2 DESCRIPTION OF TEST MODES	11
2.3 TEST SOFTWARE AND POWER LEVEL	12
2.4 BLOCK DIGRAM SHOWING THE CONFIGURATION OF SYSTEM TESTED	13
2.5 DESCRIPTION OF NECESSARY ACCESSORIES AND SUPPORT UNITS	14
2.6 EQUIPMENTS LIST FOR ALL TEST ITEMS	15
3 . EMC EMISSION TEST	16
3.1 CONDUCTED EMISSION MEASUREMENT	16
3.2 RADIATED EMISSION AND (BANDEGE) MEASUREMENT	20
4. CONDUCTED SPURIOUS EMISSIONS AND BANDEGE	41
4.1 LIMIT	41
4.2 TEST PROCEDURE	41
4.3 DEVIATION FROM STANDARD	41
4.4 TEST SETUP	42
4.5 EUT OPERATION CONDITIONS	42
4.6 TEST RESULTS	42
5. POWER SPECTRAL DENSITY TEST	43
5.1 LIMIT	43
5.2 TEST PROCEDURE	44
5.3 DEVIATION FROM STANDARD	45
5.4 TEST SETUP	45
5.5 EUT OPERATION CONDITIONS	45
5.6 TEST RESULTS	45
6. BANDWIDTH MEASUREMENT	49
6.1 EMISSION BANDWIDTH (EBW) 26 BANDWID PROCEDURES / LIMIT	49
6.2 OCCUPIED BANDWIDTH (99%) TEST APPLIED PROCEDURES / LIMIT	52
6.3 MINIMUM EMISSION BANDWIDTH(6 DB) PROCEDURES / LIMIT	55
7. MAXIMUM CONDUCTED OUTPUT POWER	57
7.1 LIMIT	57
7.2 TEST PROCEDURE	58



Table of Contents	Page
7.3 DEVIATION FROM STANDARD	58
7.4 TEST SETUP	58
7.5 EUT OPERATION CONDITIONS	58
7.6 TEST RESULTS	59
8. AUTOMATICALLY DISCONTINUE TRANSMISSION	70
8.1 LIMIT OF AUTOMATICALLY DISCONTINUE TRANSMISSION	70
8.2 TEST RESULT OF AUTOMATICALLY DISCONTINUE TRANSMISSION	70
9. ANTENNA REQUIREMENT	71
9.1 STANDARD REQUIREMENT	71
9.2 EUT ANTENNA	71
10. FREQUENCY STABILITY	72
10.1 LIMITS OF FREQUENCY STABILITY MEASUREMENT	72
10.2 TEST PROCEDURE	72
10.3 TEST RESULT	72
APPENDIX - PHOTOS OF TEST SETUP	76





Revision History

Rev.	Issue Date	Report NO.	Effect Page	Contents
00	29 Apr. 2020	STS2002171W27	ALL	Initial Issue





1. SUMMARY OF TEST RESULTS

Test procedures according to the technical standards:

§ 15.407, KDB 789033 D02 General U-NII Test Procedures New Rules v02r01

FCC Part 15.407 RSS-247 Issue 2, February 2017		
FCC standard	Test Item	Results
15.207 RSS-Gen 8.8	AC Conducted Emission	PASS
§ 15.407 (2) (26 dB) / § 15.407 (e) (6 dB) / § 15.407 (a) (99%) RSS-Gen 6.7	26dB/6dB & 99% Bandwidth	PASS
15.407(a) (1).(2).(3).(4).(5) RSS-247 6.2	Maximum Conducted Output Power	PASS
15.407(b)& 15.209 RSS-Gen 8.9 8.10	Radiated Emission And (bandedge Emissions) Measurement	PASS
15.407(b)7 RSS-247 6.2	Conducted Emission And (bandedge Emissions) Measurement	PASS
15.407(a) (1).(2).(3).(4).(5) RSS-247 6.2	Power Spectral Density	PASS
15.407(c)	Automatically Discontinue Transmission	PASS
15.203/15.204 RSS-Gen 6.8	Antenna Requirement	PASS
RSS-Gen 6.11 8.11	Frequency Stability	PASS

NOTE:

- (1) "N/A" denotes test is not applicable in this Test Report.
- (2) All tests are according to ANSI C63.10-2013.



1.1 TEST FACTORY

SHENZHEN STS TEST SERVICES CO., LTD

Add. : A 1/F, Building B, Zhuoke Science Park, No.190 Chongqing Road, HepingShequ, Fuyong Sub-District, Bao'an District, Shenzhen, Guang Dong, China

FCC test Firm Registration Number: 625569

IC test Firm Registration Number: 12108A

A2LA Certificate No.: 4338.01

1.2 MEASUREMENT UNCERTAINTY

The reported uncertainty of measurement $y \pm U$, where expanded uncertainty U is based on a standard uncertainty multiplied by a coverage factor of $k=2$, providing a level of confidence of approximately **95 %**.

No.	Item	Uncertainty
1	RF output power, conducted	$\pm 0.68\text{dB}$
2	Unwanted Emissions, conducted	$\pm 2.988\text{dB}$
3	All emissions, radiated 30-1GHz	$\pm 6.7\text{dB}$
4	All emissions, radiated 1G-6GHz	$\pm 5.5\text{dB}$
5	All emissions, radiated >6G	$\pm 5.8\text{dB}$
6	Conducted Emission (9KHz-150KHz)	$\pm 4.43\text{dB}$
7	Conducted Emission (150KHz-30MHz)	$\pm 5\text{dB}$



2. GENERAL INFORMATION

2.1 GENERAL DESCRIPTION OF THE EUT

Product Name	Rugged Tablet PC	
Trade Name	Winmate	
Model Name	M133WK	
Series Model	M133WK-DW, M133XXXXXXXXXXXX (Where X can be A-Z,a-z ,0-9, "-", Blank or Slash)	
Model Difference	Only for marketing purpose	
Product Description	The EUT is a Rugged Tablet PC	
	Operation Frequency:	IEEE 802.11a/ n(HT20)/ac(VHT20): 5.180GHz-5.240GHz IEEE 802.11n(HT40)/ac(VHT40): 5.190GHz-5.310GHz IEEE 802.11ac(VHT80): 5.210GHz IEEE 802.11a/ n(HT20)/ac(VHT20): 5.260GHz-5.320GHz IEEE 802.11n(HT40)/ac(VHT40): 5.270GHz-5.310GHz IEEE 802.11ac(VHT80): 5.290GHz IEEE 802.11a/ n(HT20)/ac(VHT20): 5.500GHz-5.700GHz IEEE 802.11n(HT40)/ac(VHT40): 5.510GHz-5.670GHz IEEE 802.11ac(VHT80): 5.530GHz-5.610GHz IEEE 802.11a/ n(HT20)/ac(VHT20): 5.745GHz-5.825GHz IEEE 802.11n(HT40)/ac(VHT40): 5.755GHz-5.795GHz IEEE 802.11ac(VHT80): 5.775GHz
	Modulation Type:	802.11a(OFDM): BPSK,QPSK,16-QAM,64-QAM 802.11n(OFDM): BPSK,QPSK,16-QAM,64-QAM 802.11ac(OFDM): BPSK,QPSK,16-QAM,64-QAM,256-QAM
	Antenna Designation:	Please refer to the Note 4.
	Max.Output Power(Conducted):	18.24 dBm
	More details of EUT technical specification, please refer to the User Manual.	
	Test Channel	Please refer to the Note 3.
	Adapter	Input: AC 100-240V, 1.7A, 50-60Hz Output: DC 19V, 3.42A
Battery	Rated Voltage: 15.4V Charge Limit: 17.6V Capacity: 5900mAh	
Hardware version number	M133DA-100	
Software version number	20.90.0	
Connecting I/O Port(s)	Please refer to the Note 1.	



Note:

1. For a more detailed features description, please refer to the manufacturer's specifications or the User Manual.
2. The EUT not support TPC function.

3. Operation Frequency of channel

5.180GHz-5.240GHz		5.500GHz-5.720GHz	
Channel	Frequency	Channel	Frequency
36	5180	100	5500
38	5190	102	5510
40	5200	104	5520
42	5210	108	5540
44	5220	110	5550
46	5230	112	5560
48	5240	116	5580
		118	5590
		120	5600
5.260GHz-5.320GHz			
Channel	Frequency	Channel	Frequency
52	5260	124	5620
54	5270	126	5630
56	5280	128	5640
58	5290	132	5660
60	5300	134	5670
62	5310	136	5680
64	5320	140	5700
5.745GHz-5.825GHz			
Channel	Frequency	Channel	Frequency
149	5745		
151	5755		
153	5765		
157	5785		
159	5795		
161	5805		
165	5825		

Note:

1. IC not support Band 5600MHz-5650MHz.
2. In section 15.31(m), regards to the operating frequency range over 10 MHz, the Lowest frequency, the middle frequency, and the highest frequency of channel were selected to perform the test, and the selected channel see below:

Carrier Frequency Channel

5GHz:

For 802.11a/n(HT20) /ac (VHT20)			
Channel	Freq.(MHz)	Channel	Freq.(MHz)
36	5180	52	5260
40	5200	60	5300
48	5240	64	5320



For 802.11a/n(HT20) /ac (VHT20)			
Channel	Freq.(MHz)	Channel	Freq.(MHz)
100	5500	149	5745
116	5580	157	5785
140	5700	165	5825

For 802.11n(HT40) /ac (VHT40)			
Channel	Freq.(MHz)	Channel	Freq.(MHz)
38	5190	54	5270
46	5230	62	5310

For 802.11n(HT40) /ac (VHT40)			
Channel	Freq.(MHz)	Channel	Freq.(MHz)
102	5510	151	5755
110	5550	159	5795
134	5670		

For 802.11ac (VHT80)			
Channel	Freq.(MHz)	Channel	Freq.(MHz)
42	5210	155	5775

For 802.11ac (VHT80)			
Channel	Freq.(MHz)	Channel	Freq.(MHz)
106	5530	155	5775
122	5610		

4.	Ant	Brand	Model Name	Ant Type	Connector	Gain (dBi)	NOTE
	A	Winmate	M133WK	PIFA	N/A	1.13 dBi	WLAN Ant



2.2 DESCRIPTION OF TEST MODES

To investigate the maximum EMI emission characteristics generates from EUT, the test system was pre-scanning tested base on the consideration of following EUT operation mode or test configuration mode which possible have effect on EMI emission level. Each of these EUT operation mode(s) or test configuration mode(s) mentioned above was evaluated respectively.

Worst Mode	Description	Data Rate
Mode 1	TX IEEE 802.11a HT20 CH36&CH40&CH48	6 Mbps
Mode 2	TX IEEE 802.11a HT20 CH52&CH60&CH64	6 Mbps
Mode 3	TX IEEE 802.11a HT20 CH100&CH116&CH140	6 Mbps
Mode 4	TX IEEE 802.11a HT20 CH149&CH157&CH165	6 Mbps
Mode 5	TX IEEE 802.11n HT20 CH36&CH40&CH48	MCS 0
Mode 6	TX IEEE 802.11ac HT20 CH36&CH40&CH48	NSS1 MCS0
Mode 7	TX IEEE 802.11n HT20 CH52&CH60&CH64	MCS 0
Mode 8	TX IEEE 802.11ac HT20 CH52&CH60&CH64	NSS1 MCS0
Mode 9	TX IEEE 802.11n HT20 CH100&CH116&CH140	MCS 0
Mode 10	TX IEEE 802.11ac HT20 CH100&CH116&CH140	NSS1 MCS0
Mode 11	TX IEEE 802.11n HT20 CH149&CH157&CH165	MCS 0
Mode 12	TX IEEE 802.11ac HT20 CH149&CH157&CH165	NSS1 MCS0
Mode 13	TX IEEE 802.11n HT40 CH38&CH46	MCS 0
Mode 14	TX IEEE 802.11ac HT40 CH38&CH46	NSS1 MCS0
Mode 15	TX IEEE 802.11n HT40 CH54 &CH62	MCS 0
Mode 16	TX IEEE 802.11ac HT40 CH54 &CH62	NSS1 MCS0
Mode 17	TX IEEE 802.11n HT40 CH102&CH110&CH134	MCS 0
Mode 18	TX IEEE 802.11ac HT40 CH102&CH110&CH134	NSS1 MCS0
Mode 19	TX IEEE 802.11n HT40 CH151&CH159	MCS 0
Mode 20	TX IEEE 802.11ac HT40 CH151&CH159	NSS1 MCS0
Mode 21	TX IEEE 802.11ac HT80 CH42	NSS1 MCS0
Mode 22	TX IEEE 802.11ac HT80 CH58	NSS1 MCS0
Mode 23	TX IEEE 802.11ac HT80 CH106&122	NSS1 MCS0
Mode 24	TX IEEE 802.11ac HT80 CH155	NSS1 MCS0

- Note: (1) The measurements are performed at the highest, middle, lowest available channels.
 (2) The measurements are performed at all Bit Rate of Transmitter, the worst data was reported.
 (3) We have be tested for all avaiable U.S. voltage and frequencies(For 120V,50/60Hz and 240V, 50/60Hz) for which the device is capable of operation.



AC Conducted Emission

Test Case	
AC Conducted Emission	Mode 25: Keeping TX + WLAN Link

2.3 TEST SOFTWARE AND POWER LEVEL

During testing channel & power controlling software provided by the customer was used to control the operating channel as well as the output power level.

RF Function	Type	Mode Or Modulation type	Ant Gain(dBi)	Power Class	Software For Testing
WIFI(5G)	5G WIFI Band1 (5150MHz-5250MHz)	802.11a	1.13	35	MP Tool
		802.11n(HT20)		35	
		802.11n(HT20)		35	
		802.11ac(VHT20)		35	
		802.11ac(VHT40)		35	
		802.11ac(VHT80)		35	
	5G WIFI Band2 (5250MHz-5350MHz)	802.11a	1.13	35	
		802.11n(HT20)		35	
		802.11n(HT20)		35	
		802.11ac(VHT20)		35	
		802.11ac(VHT40)		35	
		802.11ac(VHT80)		35	
	5G WIFI Band3 (5470MHz-5725MHz)	802.11a	1.13	35	
		802.11n(HT20)		35	
		802.11n(HT20)		35	
		802.11ac(VHT20)		35	
		802.11ac(VHT40)		35	
		802.11ac(VHT80)		35	
	5G WIFI Band4 (5725MHz-5875MHz)	802.11a	1.13	35	
		802.11n(HT20)		35	
		802.11n(HT20)		35	
		802.11ac(VHT20)		35	
		802.11ac(VHT40)		35	
		802.11ac(VHT80)		35	

2.4 BLOCK DIGRAM SHOWING THE CONFIGURATION OF SYSTEM TESTED

Radiated Spurious Emission Test

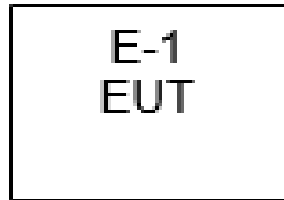

Conducted Emission Test

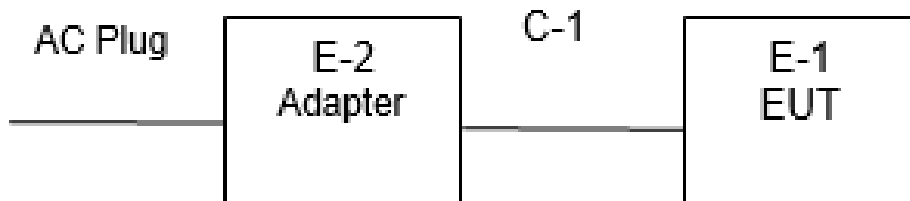



2.5 DESCRIPTION OF NECESSARY ACCESSORIES AND SUPPORT UNITS

The EUT has been tested as an independent unit together with other necessary accessories or support units. The following support units or accessories were used to form a representative test configuration during the tests.

Necessary accessories

Item	Equipment	Mfr/Brand	Model/Type No.	Serial No.	Note
E-2	Adapter	Chicony	A18-065N3A	N/A	N/A
C-1	DC Cable	N/A	110cm	N/A	N/A

Support units

Item	Equipment	Mfr/Brand	Model/Type No.	Serial No.	Note
N/A	N/A	N/A	N/A	N/A	N/A

Note:

- (1) The support equipment was authorized by Declaration of Confirmation.
- (2) For detachable type I/O cable should be specified the length in cm in 『Length』 column.



2.6 EQUIPMENTS LIST FOR ALL TEST ITEMS

Radiation Test equipment

Kind of Equipment	Manufacturer	Type No.	Serial No.	Last calibration	Calibrated until
EMI Test Receiver	R&S	ESCI	101427	2019.07.29	2020.07.28
Signal Analyzer	Agilent	N9020A	MY51110105	2020.03.05	2021.03.04
Active loop Antenna	ZHINAN	ZN30900C	16035	2018.03.11	2021.03.10
Bilog Antenna	TESEQ	CBL6111D	34678	2017.11.02	2020.11.01
Horn Antenna	SCHWARZBECK	BBHA 9120D(1201)	9120D-1343	2018.10.19	2021.10.18
Horn Antenna (18-40GHz)	A-INFO	LB-180400-KF	J211020657	2018.03.11	2021.03.10
Pre-Amplifier (18G-40G)	SKET	LNPA_1840-50	SK2018101801	2019.10.22	2020.10.21
Spectrum Analyzer	R&S	FSV40-N	101823	2019.06.05	2020.06.04
Pre-Amplifier (0.1M-3GHz)	EM	EM330	060665	2019.10.09	2020.10.08
Pre-Amplifier (1G-18GHz)	SKET	LNPA-01018G-4 5	SK2018080901	2019.10.12	2020.10.11
Temperature & Humidity	HH660	Mieo	N/A	2019.10.12	2020.10.11
Turn table	EM	SC100_1	60531	N/A	N/A
Antenna mast	EM	SC100	N/A	N/A	N/A
Test SW	BULUN	BL410-E/18.905			

Conduction Test equipment

Kind of Equipment	Manufacturer	Type No.	Serial No.	Last calibration	Calibrated until
Test Receiver	R&S	ESCI	101427	2019.07.29	2020.07.28
LISN	R&S	ENV216	101242	2019.10.09	2020.10.08
LISN	EMCO	3810/2NM	23625	2019.10.09	2020.10.08
Temperature & Humidity	HH660	Mieo	N/A	2019.10.12	2020.10.11
Test SW	FARAD	EZ-EMC(Ver.STSLAB-03A1 CE)			

RF Connected Test

Kind of Equipment	Manufacturer	Type No.	Serial No.	Last calibration	Calibrated until
USB RF power sensor	DARE	RPR3006W	15I00041SNO03	2019.10.09	2020.10.08
Signal Analyzer	Agilent	N9020A	MY49100060	2019.10.09	2020.10.08
Temperature & Humidity	HH660	Mieo	N/A	2019.10.12	2020.10.11
Test SW	FARAD	LZ-RF /LzRf-3A3			



3. EMC EMISSION TEST

3.1 CONDUCTED EMISSION MEASUREMENT

3.1.1 POWER LINE CONDUCTED EMISSION Limits (Frequency Range 150KHz-30MHz)

FREQUENCY (MHz)	Class B (dBuV)		Standard
	Quasi-peak	Average	
0.15 -0.5	66 - 56 *	56 - 46 *	CISPR
0.50 -5.0	56.00	46.00	CISPR
5.0 -30.0	60.00	50.00	CISPR

0.15 -0.5	66 - 56 *	56 - 46 *	FCC
0.50 -5.0	56.00	46.00	FCC
5.0 -30.0	60.00	50.00	FCC

Note:

- (1) The tighter limit applies at the band edges.
- (2) The limit of " * " marked band means the limitation decreases linearly with the logarithm of the frequency in the range.

The following table is the setting of the receiver

Receiver Parameters	Setting
Attenuation	10 dB
Start Frequency	0.15 MHz
Stop Frequency	30 MHz
IF Bandwidth	9 kHz

3.1.2 TEST PROCEDURE

- a. The EUT was placed 0.8 meters from the horizontal ground plane with EUT being connected to the power mains through a line impedance stabilization network (LISN). All other support equipments powered from additional LISN(s). The LISN provide 50 Ohm/ 50uH of coupling impedance for the measuring instrument.
- b. Interconnecting cables that hang closer than 40 cm to the ground plane shall be folded back and forth in the center forming a bundle 30 to 40 cm long.
- c. I/O cables that are not connected to a peripheral shall be bundled in the center. The end of the cable may be terminated, if required, using the correct terminating impedance. The overall length shall not exceed 1 m.
- d. LISN at least 80 cm from nearest part of EUT chassis.
- e. For the actual test configuration, please refer to the related Item –EUT Test Photos.

3.1.3 DEVIATION FROM TEST STANDARD

No deviation

3.1.4 TEST SETUP

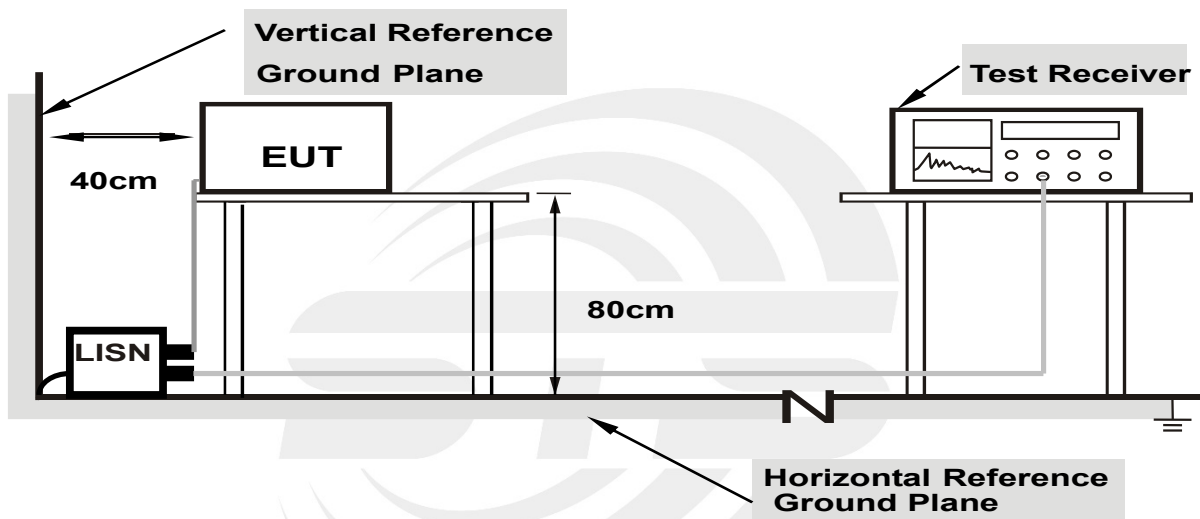

- Note: 1.Support units were connected to second LISN.**
2.Both of LISNs (AMN) are 80 cm from EUT and at least 80 from other units and other metal planes

3.1.5 EUT OPERATING CONDITIONS

The EUT was configured for testing in a typical fashion (as a customer would normally use it). The EUT has been programmed to continuously transmit during test. This operating condition was tested and used to collect the included data.



3.1.6 TEST RESULTS

Temperature:	23.5(C)	Relative Humidity:	62%RH
Test Voltage:	AC 120V/60Hz	Phase:	L
Test Mode :	Mode 25		

No.	Frequency (MHz)	Reading (dBuV)	Correct Factor(dB)	Result (dBuV)	Limit (dBuV)	Margin (dB)	Remark
1	0.1620	35.46	19.79	55.25	65.36	-10.11	QP
2	0.1620	20.47	19.79	40.26	55.36	-15.10	AVG
3	0.5380	16.37	19.99	36.36	56.00	-19.64	QP
4	0.5380	6.25	19.99	26.24	46.00	-19.76	AVG
5	1.2740	11.72	19.79	31.51	56.00	-24.49	QP
6	1.2740	2.10	19.79	21.89	46.00	-24.11	AVG
7	4.3140	17.78	19.84	37.62	56.00	-18.38	QP
8	4.3140	3.30	19.84	23.14	46.00	-22.86	AVG
9	16.1940	26.66	20.29	46.95	60.00	-13.05	QP
10	16.1940	16.84	20.29	37.13	50.00	-12.87	AVG
11	26.6220	12.02	20.20	32.22	60.00	-27.78	QP
12	26.6220	7.01	20.20	27.21	50.00	-22.79	AVG

Remark:

1. All readings are Quasi-Peak and Average values.
2. Margin = Result (Result = Reading + Factor) – Limit

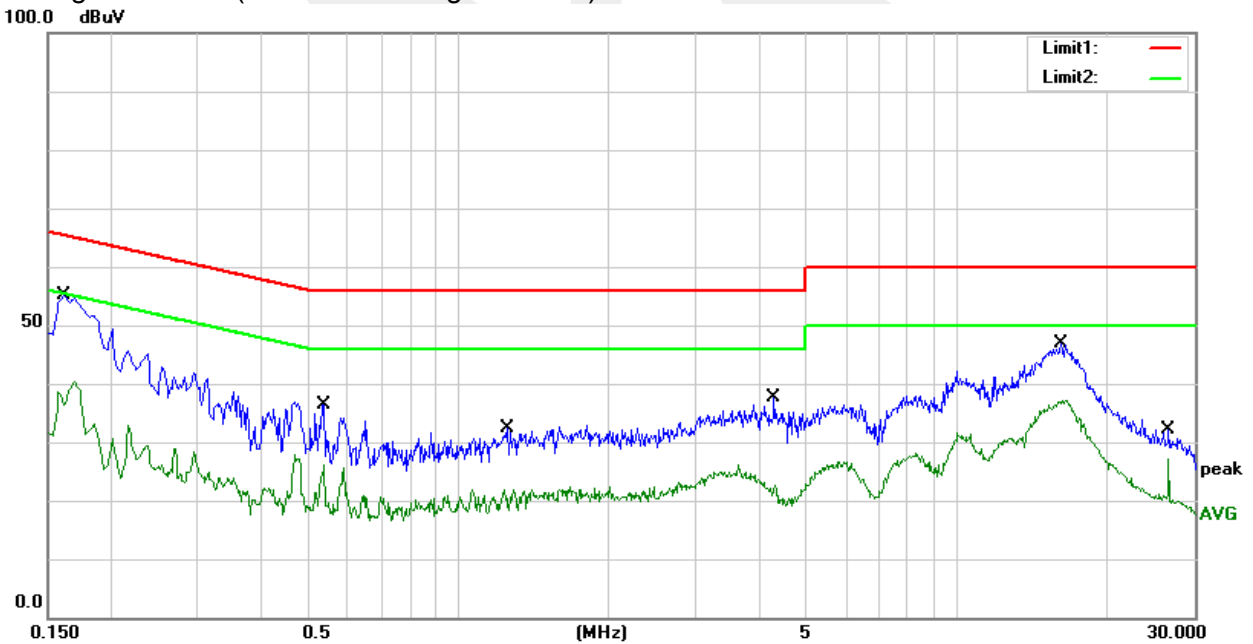



Temperature:	23.5(C)	Relative Humidity:	62%RH
Test Voltage	AC 120V/60Hz	Phase:	N
Test Mode	Mode 25		

No.	Frequency (MHz)	Reading (dBuV)	Correct Factor(dB)	Result (dBuV)	Limit (dBuV)	Margin (dB)	Remark
1	0.1700	36.04	19.79	55.83	64.96	-9.13	QP
2	0.1700	19.93	19.79	39.72	54.96	-15.24	AVG
3	0.5580	17.47	19.97	37.44	56.00	-18.56	QP
4	0.5580	8.32	19.97	28.29	46.00	-17.71	AVG
5	1.4380	12.67	19.79	32.46	56.00	-23.54	QP
6	1.4380	1.97	19.79	21.76	46.00	-24.24	AVG
7	3.9700	18.47	19.83	38.30	56.00	-17.70	QP
8	3.9700	3.45	19.83	23.28	46.00	-22.72	AVG
9	9.0300	18.75	20.10	38.85	60.00	-21.15	QP
10	9.0300	4.78	20.10	24.88	50.00	-25.12	AVG
11	16.7180	22.97	20.32	43.29	60.00	-16.71	QP
12	16.7180	13.49	20.32	33.81	50.00	-16.19	AVG

Remark:

1. All readings are Quasi-Peak and Average values.
2. Margin = Result (Result = Reading + Factor) - Limit

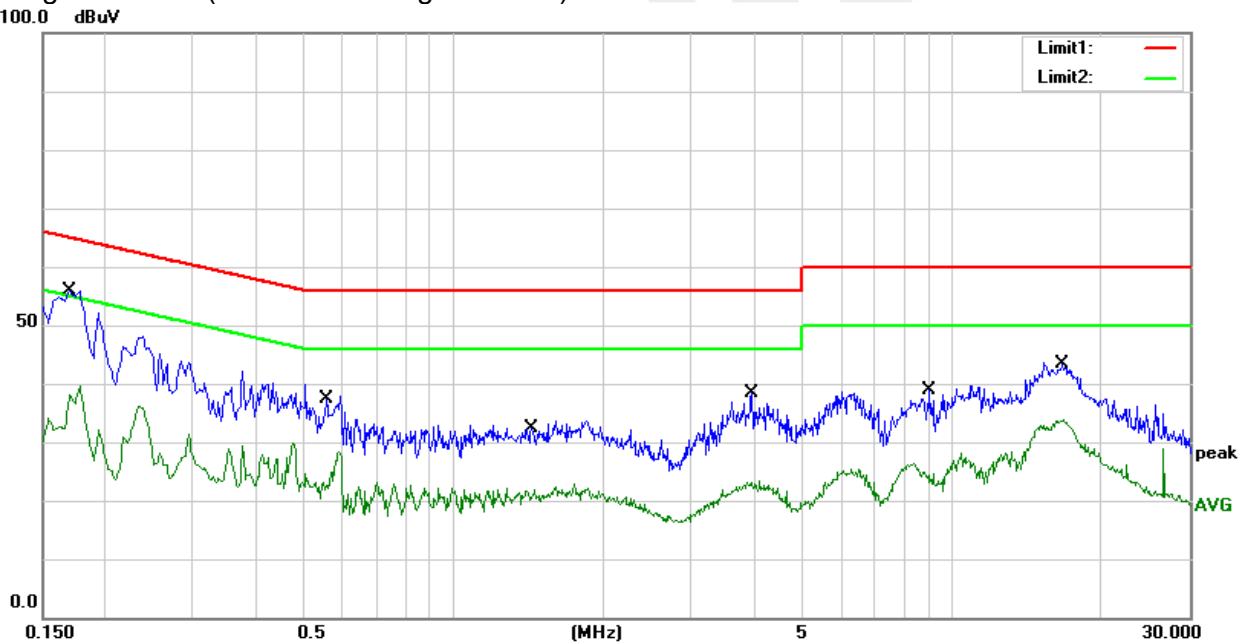

3.2 RADIATED EMISSION AND (BANDEDGE) MEASUREMENT

3.2.1 RADIATED EMISSION LIMITS (Frequency Range 9kHz-1000MHz)

In case the emission fall within the restricted band; limit in the table below has to be followed.

Frequencies (MHz)	Field Strength (microrvolts/meter)	Measurement Distance (meters)
0.009~0.490	2400/F(KHz)	300
0.490~1.705	24000/F(KHz)	30
1.705~30.0	30	30
30~88	100	3
88~216	150	3
216~960	200	3
Above 960	500	3

LIMITS OF RADIATED EMISSION MEASUREMENT (Above 1000MHz)

FREQUENCY (MHz)	Class B (dBuV/m) (at 3M)	
	PEAK	AVERAGE
Above 1000	68.2	54

Notes:

- (1) The limit for radiated test was performed according to FCC PART 15E.
- (2) The tighter limit applies at the band edges.
- (3) Emission level (dBuV/m)=20log Emission level (uV/m).

LIMITS OF RESTRICTED FREQUENCY BANDS

FCC:

FREQUENCY (MHz)	FREQUENCY (MHz)	FREQUENCY (MHz)	FREQUENCY (GHz)
0.090-0.110	16.42-16.423	399.9-410	4.5-5.15
0.495-0.505	16.69475-16.69525	608-614	5.35-5.46
2.1735-2.1905	16.80425-16.80475	960-1240	7.25-7.75
4.125-4.128	25.5-25.67	1300-1427	8.025-8.5
4.17725-4.17775	37.5-38.25	1435-1626.5	9.0-9.2
4.20725-4.20775	73-74.6	1645.5-1646.5	9.3-9.5
6.215-6.218	74.8-75.2	1660-1710	10.6-12.7
6.26775-6.26825	108-121.94	1718.8-1722.2	13.25-13.4
6.31175-6.31225	123-138	2200-2300	14.47-14.5
8.291-8.294	149.9-150.05	2310-2390	15.35-16.2
8.362-8.366	156.52475-156.52525	2483.5-2500	17.7-21.4
8.37625-8.38675	156.7-156.9	2690-2900	22.01-23.12
8.41425-8.41475	162.0125-167.17	3260-3267	23.6-24.0
12.29-12.293	167.72-173.2	3332-3339	31.2-31.8
12.51975-12.52025	240-285	3345.8-3358	36.43-36.5
12.57675-12.57725	322-335.4	3600-4400	Above 38.6
13.36-13.41			



IC:

FREQUENCY (MHz)	FREQUENCY (MHz)	FREQUENCY (GHz)
0.090 - 0.110	149.9 - 150.05	9.0 - 9.2
0.495 - 0.505	156.52475 - 156.52525	9.3 - 9.5
2.1735 - 2.1905	156.7 - 156.9	10.6 - 12.7
3.020 - 3.026	162.0125 - 167.17	13.25 - 13.4
4.125 - 4.128	167.72 - 173.2	14.47 - 14.5
4.17725 - 4.17775	240 - 285	15.35 - 16.2
4.20725 - 4.20775	322 - 335.4	17.7 - 21.4
5.677 - 5.683	399.9 - 410	22.01 - 23.12
6.215 - 6.218	608 - 614	23.6 - 24.0
6.26775 - 6.26825	960 - 1427	31.2 - 31.8
6.31175 - 6.31225	1435 - 1626.5	36.43 - 36.5
8.291 - 8.294	1645.5 - 1646.5	Above 38.6
8.362 - 8.366	1660 - 1710	
8.37625 - 8.38675	1718.8 - 1722.2	
8.41425 - 8.41475	2200 - 2300	
12.29 - 12.293	2310 - 2390	
12.51975 - 12.52025	2483.5 - 2500	
12.57675 - 12.57725	2655 - 2900	
13.36 - 13.41	3260 - 3267	
16.42 - 16.423	3332 - 3339	
16.69475 - 16.69525	3345.8 - 3358	
16.80425 - 16.80475	3500 - 4400	
25.5 - 25.67	4500 - 5150	
37.5 - 38.25	5350 - 5460	
73 - 74.6	7250 - 7750	
74.8 - 75.2	8025 - 8500	
108 - 138		



Spectrum Parameter	Setting
Attenuation	Auto
Detector	Peak
Start Frequency	1000 MHz(Peak/AV)
Stop Frequency	10th carrier harmonic (Peak/AV)
RB / VB (emission in restricted band)	1 MHz / 1 MHz, AV=1 MHz /3 MHz

For Band edge

Spectrum Parameter	Setting
Detector	Peak
RB / VB (emission in restricted band)	1 MHz / 1 MHz, AV=1 MHz /3 MHz

Receiver Parameter	Setting
Attenuation	Auto
Start ~ Stop Frequency	9kHz~90kHz / RB 200Hz for PK & AV
Start ~ Stop Frequency	90kHz~110kHz / RB 200Hz for QP
Start ~ Stop Frequency	110kHz~490kHz / RB 200Hz for PK & AV
Start ~ Stop Frequency	490kHz~30MHz / RB 9kHz for QP
Start ~ Stop Frequency	30MHz~1000MHz / RB 120kHz for QP

3.2.2 TEST PROCEDURE

- a. The measuring distance of at 3 m shall be used for measurements at frequency 0.009MHz up to 1GHz. For frequencies above 1GHz, any suitable measuring distance may be used.
- b. The EUT was placed on the top of a rotating table 0.8 meters(above 1GHz is 1.5 m) above the ground at a 3 meter anechoic chamber. The table was rotated 360 degrees to determine the position of the highest radiation.
- c. The height of the equipment shall be 0.8 m(above 1GHz is 1.5 m); the height of the test antenna shall vary between 1 m to 4 m. Horizontal and vertical polarizations of the antenna are set to make the measurement
- d. The initial step in collecting conducted emission data is a spectrum analyzer peak detector mode pre-scanning the measurement frequency range. Significant peaks are then marked and then Quasi Peak detector mode re-measured.
- e. If the Peak Mode measured value compliance with and lower than Quasi Peak Mode Limit, the EUT shall be deemed to meet QP Limits and then no additional QP Mode measurement performed.
- f. For the actual test configuration, please refer to the related Item –EUT Test Photos.

Note:

Both horizontal and vertical antenna polarities were tested and performed test to three orthogonal axis. The worst case emissions were reported

3.2.2 DEVIATION FROM TEST STANDARD

No deviation

3.2.3 TEST SETUP

(A) Radiated Emission Test-Up Frequency Below 30MHz

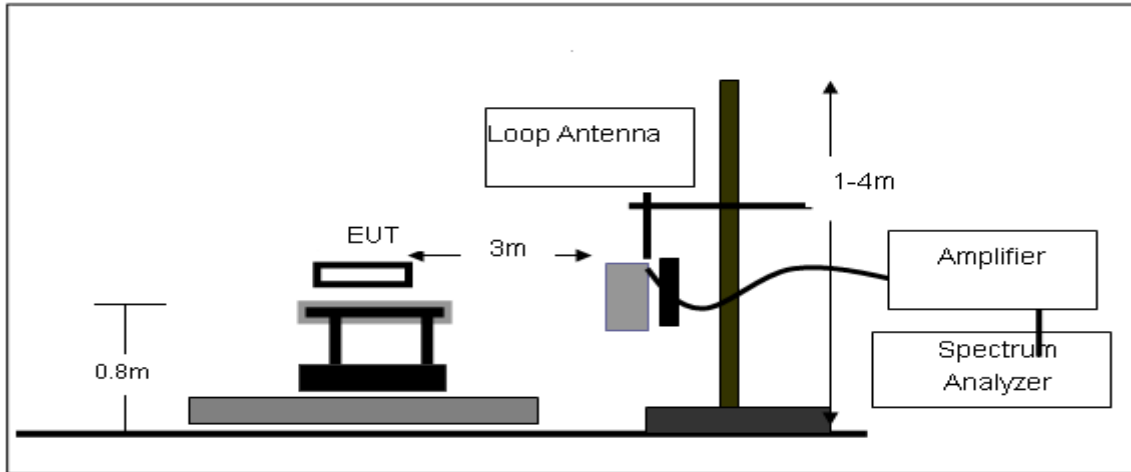

(B) Radiated Emission Test-Up Frequency 30MHz~1GHz

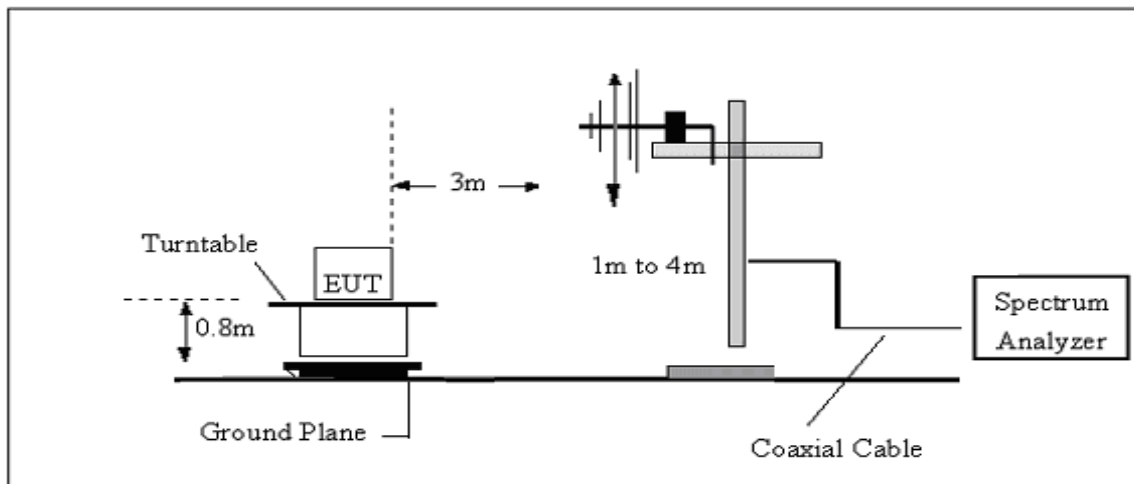

(C) Radiated Emission Test-Up Frequency Above 1GHz

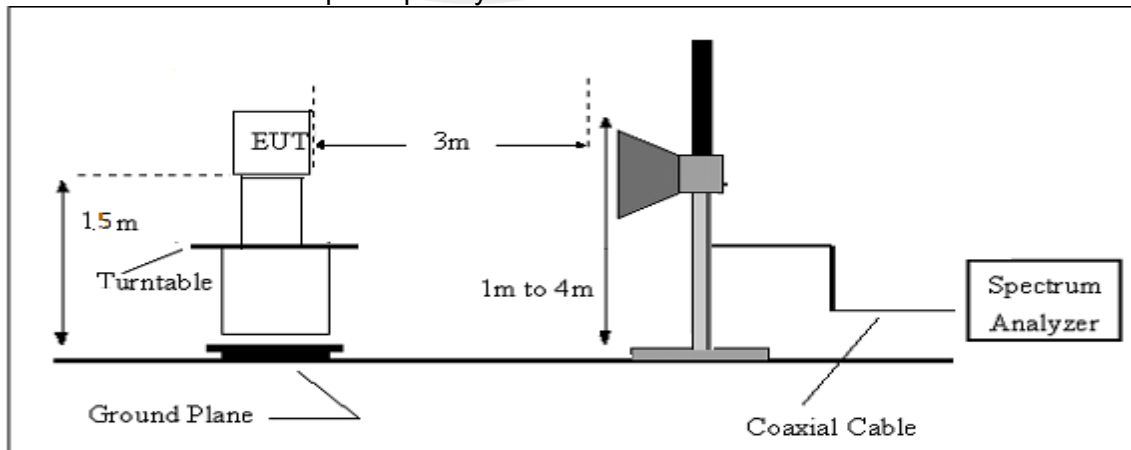



3.2.4 EUT OPERATING CONDITIONS

The EUT tested system was configured as the statements of 2.4 Unless otherwise a special operating condition is specified in the follows during the testing.

3.2.5 FIELD STRENGTH CALCULATION

The field strength is calculated by adding the Antenna Factor and Cable Factor and subtracting the Amplifier Gain and Duty Cycle Correction Factor (if any) from the measured reading. The basic equation with a sample calculation is as follows:

$$FS = RA + AF + CL - AG$$

Where

FS = Field Strength

CL = Cable Attenuation Factor (Cable Loss)

RA = Reading Amplitude

AG = Amplifier Gain

AF = Antenna Factor

For example

Frequency (MHz)	FS (dB μ V/m)	RA (dB μ V/m)	AF (dB)	CL (dB)	AG (dB)	Factor (dB)
300	40	58.1	12.2	1.6	31.9	-18.1

$$\text{Factor} = \text{AF} + \text{CL} - \text{AG}$$

**3.2.6 TEST RESULTS (Between 9KHz – 30 MHz)**

Temperature:	22.7(C)	Relative Humidity:	61%RH
Test Voltage :	DC 15.4V	Polarization :	--
Test Mode :	TX Mode		

Freq. (MHz)	Reading (dBuV/m)	Limit (dBuV/m)	Margin (dB)	State P/F
--	--	--	--	PASS
--	--	--	--	PASS

Note:

The amplitude of spurious emissions which are attenuated by more than 20dB below the permissible value has no need to be reported.

Distance extrapolation factor = $40 \log(\text{specific distance}/\text{test distance})$ (dB);

Limit line = specific limits(dBuV) + distance extrapolation factor.

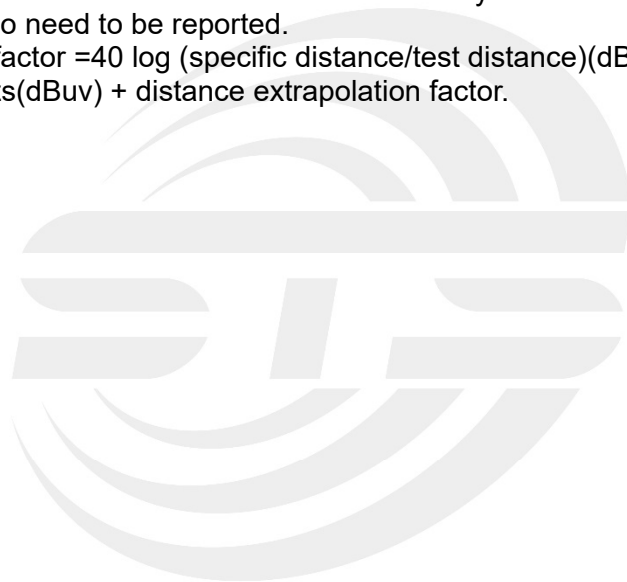



3.2.7 TEST RESULTS (Between 30MHz – 1GHz)

Temperature	22.7(C)	Relative Humidity:	61%RH
Test Voltage	DC 15.4V	Polarization:	Horizontal
Test Mode	Mode 1~24(Mode 2 worst mode)		

No.	Frequency (MHz)	Reading (dBuV)	Correct Factor(dB/m)	Result (dBuV/m)	Limit (dBuV/m)	Margin (dB)	Remark
1	30.0000	29.60	-12.85	16.75	40.00	-23.25	QP
2	246.3100	40.06	-16.76	23.30	46.00	-22.70	QP
3	298.6900	41.05	-14.86	26.19	46.00	-19.81	QP
4	576.1100	33.65	-5.70	27.95	46.00	-18.05	QP
5	834.1300	43.70	-0.59	43.11	46.00	-2.89	QP
6	982.5400	30.58	2.52	33.10	54.00	-20.90	QP

Remark:

1. Margin = Result (Result =Reading + Factor)–Limit

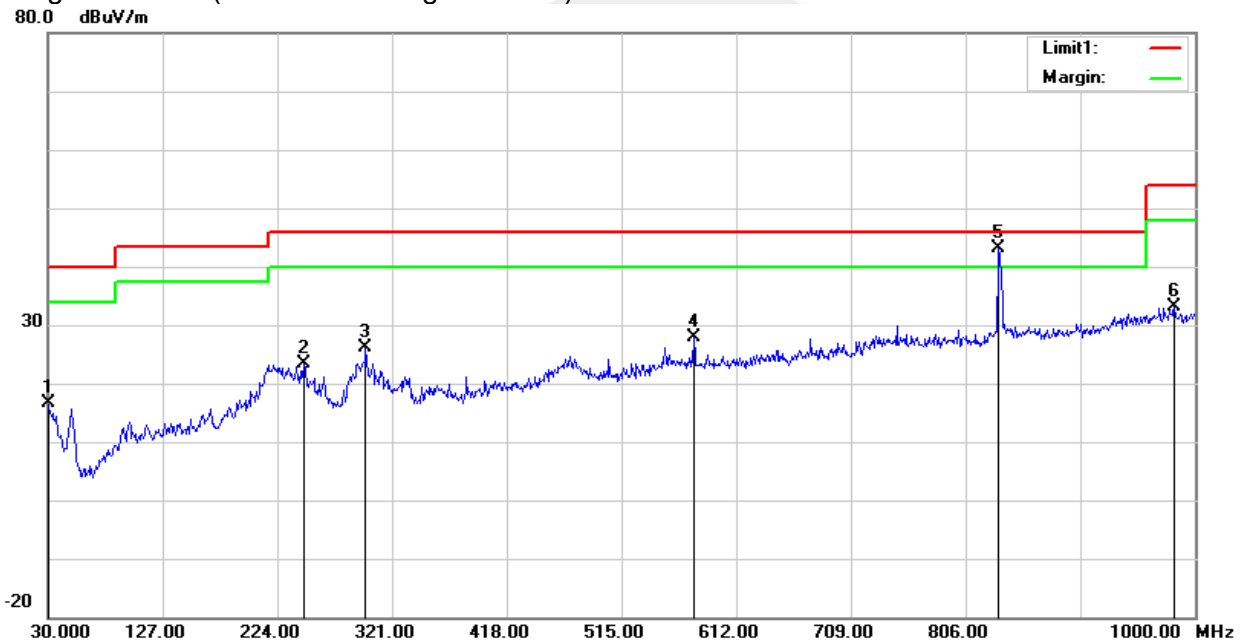



Temperature	22.7(C)	Relative Humidity:	61%RH
Test Voltage	DC 15.4V	Polarization:	Vertical
Test Mode	Mode 1~24(Mode 2 worst mode)		

No.	Frequency (MHz)	Reading (dBuV)	Correct Factor(dB/m)	Result (dBuV/m)	Limit (dBuV/m)	Margin (dB)	Remark
1	99.8400	36.76	-20.15	16.61	43.50	-26.89	QP
2	215.2700	47.62	-20.17	27.45	43.50	-16.05	QP
3	300.6300	41.26	-14.79	26.47	46.00	-19.53	QP
4	576.1100	31.74	-5.70	26.04	46.00	-19.96	QP
5	836.0700	41.65	-0.50	41.15	46.00	-4.85	QP
6	985.4500	30.88	2.33	33.21	54.00	-20.79	QP

Remark:

1. Margin = Result (Result =Reading + Factor)–Limit

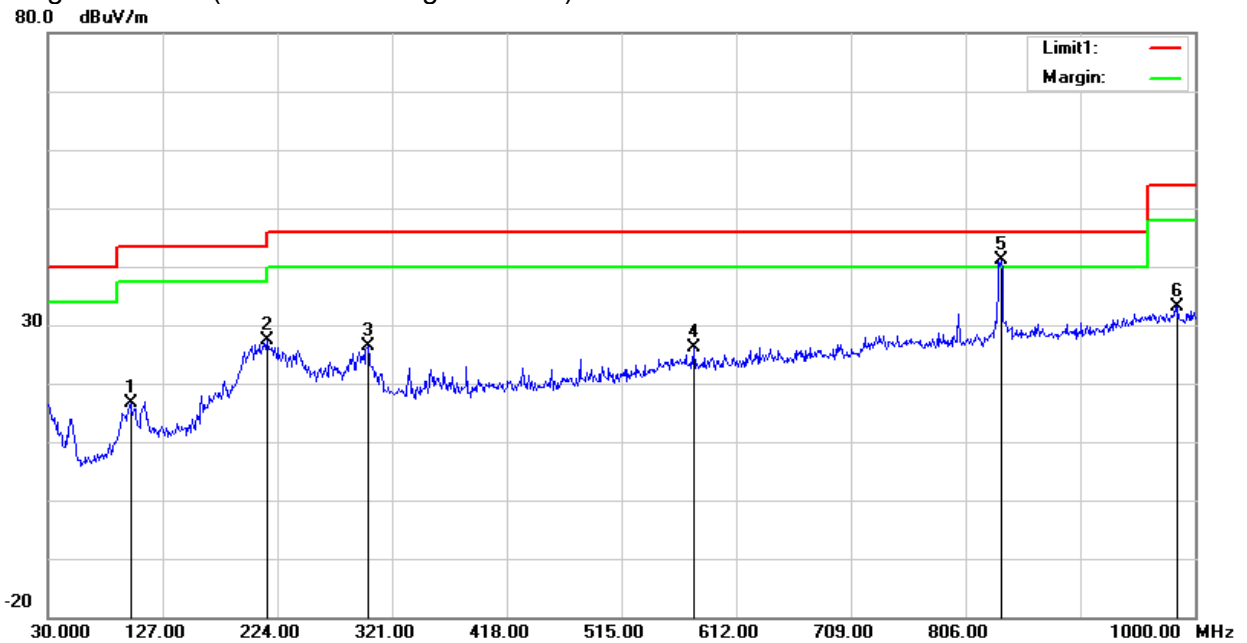



3.2.8 TEST RESULTS (Above 1000 MHz)

Band I 5150-5250MHz

Frequency (MHz)	Reading (dBuV)	Amplifier (dB)	Loss (dB)	Antenna Factor (dB/m)	Orrected Factor (dB)	Emission Level (dBuV/m)	Limit (dBuV/m)	Margin (dB)	Detector	Comment
Low Channel (802.11a/ 5180 MHz)										
3255.84	44.16	44.70	6.70	28.20	-9.80	34.36	68.20	-33.84	Pk	Vertical
3255.84	41.09	44.70	6.70	28.20	-9.80	31.29	54.00	-22.71	AV	Vertical
3260.74	45.23	44.70	6.70	28.20	-9.80	35.43	68.20	-32.77	Pk	Horizontal
3260.74	41.53	44.70	6.70	28.20	-9.80	31.73	54.00	-22.27	AV	Horizontal
3993.82	38.71	44.20	7.90	29.70	-6.60	32.11	68.20	-36.09	Pk	Vertical
3993.82	36.91	44.20	7.90	29.70	-6.60	30.31	54.00	-23.69	AV	Vertical
3980.42	39.56	44.20	7.90	29.70	-6.60	32.96	68.20	-35.24	Pk	Horizontal
3980.42	35.98	44.20	7.90	29.70	-6.60	29.38	54.00	-24.62	AV	Horizontal
7219.36	36.80	43.50	11.40	35.50	3.40	40.20	68.20	-28.00	Pk	Vertical
7219.36	33.45	43.50	11.40	35.50	3.40	36.85	54.00	-17.15	AV	Vertical
7217.27	36.85	43.50	11.40	35.50	3.40	40.25	68.20	-27.95	Pk	Horizontal
7217.27	34.76	43.50	11.40	35.50	3.40	38.16	54.00	-15.84	AV	Horizontal
10360.25	40.02	44.50	13.80	38.80	8.10	48.12	68.20	-20.08	Pk	Vertical
10360.25	37.10	44.50	13.80	38.80	8.10	45.20	54.00	-8.80	AV	Vertical
10360.42	38.84	44.50	13.80	38.80	8.10	46.94	68.20	-21.26	Pk	Horizontal
10360.42	36.86	44.50	13.80	38.80	8.10	44.96	54.00	-9.04	AV	Horizontal
11023.51	33.32	43.60	14.30	39.50	10.20	43.52	68.20	-24.68	Pk	Vertical
11023.51	31.06	43.60	14.30	39.50	10.20	41.26	54.00	-12.74	AV	Vertical
11017.30	33.88	43.60	14.30	39.50	10.20	44.08	68.20	-24.12	Pk	Horizontal
11017.30	30.81	43.60	14.30	39.50	10.20	41.01	54.00	-12.99	AV	Horizontal
13285.05	32.75	42.60	15.90	38.90	12.20	44.95	68.20	-23.25	Pk	Vertical
13285.05	29.31	42.60	15.90	38.90	12.20	41.51	54.00	-12.49	AV	Vertical
13287.37	32.79	42.60	15.90	38.90	12.20	44.99	68.20	-23.21	Pk	Horizontal
13287.37	29.32	42.60	15.90	38.90	12.20	41.52	54.00	-12.48	AV	Horizontal
Mid Channel (802.11a/ 5200 MHz)										
3257.78	43.94	44.70	6.70	28.20	-9.80	34.14	68.20	-34.06	Pk	Vertical
3257.78	41.70	44.70	6.70	28.20	-9.80	31.90	54.00	-22.10	AV	Vertical
3257.51	45.19	44.70	6.70	28.20	-9.80	35.39	68.20	-32.81	Pk	Horizontal
3257.51	41.46	44.70	6.70	28.20	-9.80	31.66	54.00	-22.34	AV	Horizontal
3993.62	39.48	44.20	7.90	29.70	-6.60	32.88	68.20	-35.32	Pk	Vertical
3993.62	35.69	44.20	7.90	29.70	-6.60	29.09	54.00	-24.91	AV	Vertical
3986.98	39.46	44.20	7.90	29.70	-6.60	32.86	68.20	-35.34	Pk	Horizontal
3986.98	36.22	44.20	7.90	29.70	-6.60	29.62	54.00	-24.38	AV	Horizontal
7223.80	37.62	43.50	11.40	35.50	3.40	41.02	68.20	-27.18	Pk	Vertical
7223.80	34.49	43.50	11.40	35.50	3.40	37.89	54.00	-16.11	AV	Vertical
7229.60	37.56	43.50	11.40	35.50	3.40	40.96	68.20	-27.24	Pk	Horizontal
7229.60	33.63	43.50	11.40	35.50	3.40	37.03	54.00	-16.97	AV	Horizontal
10399.95	38.81	44.50	13.80	38.80	8.10	46.91	68.20	-21.29	Pk	Vertical
10399.95	36.64	44.50	13.80	38.80	8.10	44.74	54.00	-9.26	AV	Vertical
10400.20	39.42	44.50	13.80	38.80	8.10	47.52	68.20	-20.68	Pk	Horizontal
10400.20	37.05	44.50	13.80	38.80	8.10	45.15	54.00	-8.85	AV	Horizontal
11028.07	33.86	43.60	14.30	39.50	10.20	44.06	68.20	-24.14	Pk	Vertical
11028.07	30.17	43.60	14.30	39.50	10.20	40.37	54.00	-13.63	AV	Vertical
11029.26	33.36	43.60	14.30	39.50	10.20	43.56	68.20	-24.64	Pk	Horizontal
11029.26	29.89	43.60	14.30	39.50	10.20	40.09	54.00	-13.91	AV	Horizontal
13289.02	31.53	42.60	15.90	38.90	12.20	43.73	68.20	-24.47	Pk	Vertical
13289.02	29.96	42.60	15.90	38.90	12.20	42.16	54.00	-11.84	AV	Vertical
13285.30	31.86	42.60	15.90	38.90	12.20	44.06	68.20	-24.14	Pk	Horizontal
13285.30	29.78	42.60	15.90	38.90	12.20	41.98	54.00	-12.02	AV	Horizontal



High Channel (802.11a/ 5240 MHz)										
3261.53	43.80	44.70	6.70	28.20	-9.80	34.00	68.20	-34.20	Pk	Vertical
3261.53	42.14	44.70	6.70	28.20	-9.80	32.34	54.00	-21.66	AV	Vertical
3253.25	44.62	44.70	6.70	28.20	-9.80	34.82	68.20	-33.38	Pk	Horizontal
3253.25	41.61	44.70	6.70	28.20	-9.80	31.81	54.00	-22.19	AV	Horizontal
3995.17	39.97	44.20	7.90	29.70	-6.60	33.37	68.20	-34.83	Pk	Vertical
3995.17	36.84	44.20	7.90	29.70	-6.60	30.24	54.00	-23.76	AV	Vertical
3989.05	39.29	44.20	7.90	29.70	-6.60	32.69	68.20	-35.51	Pk	Horizontal
3989.05	36.84	44.20	7.90	29.70	-6.60	30.24	54.00	-23.76	AV	Horizontal
7229.70	37.70	43.50	11.40	35.50	3.40	41.10	68.20	-27.10	Pk	Vertical
7229.70	34.31	43.50	11.40	35.50	3.40	37.71	54.00	-16.29	AV	Vertical
7228.25	37.48	43.50	11.40	35.50	3.40	40.88	68.20	-27.32	Pk	Horizontal
7228.25	34.83	43.50	11.40	35.50	3.40	38.23	54.00	-15.77	AV	Horizontal
10480.34	39.31	44.50	13.80	38.80	8.10	47.41	68.20	-20.79	Pk	Vertical
10480.34	37.00	44.50	13.80	38.80	8.10	45.10	54.00	-8.90	AV	Vertical
10480.02	39.75	44.50	13.80	38.80	8.10	47.85	68.20	-20.35	Pk	Horizontal
10480.02	36.83	44.50	13.80	38.80	8.10	44.93	54.00	-9.07	AV	Horizontal
11024.19	33.01	43.60	14.30	39.50	10.20	43.21	68.20	-24.99	Pk	Vertical
11024.19	30.65	43.60	14.30	39.50	10.20	40.85	54.00	-13.15	AV	Vertical
11035.21	32.85	43.60	14.30	39.50	10.20	43.05	68.20	-25.15	Pk	Horizontal
11035.21	30.99	43.60	14.30	39.50	10.20	41.19	54.00	-12.81	AV	Horizontal
13289.92	32.48	42.60	15.90	38.90	12.20	44.68	68.20	-23.52	Pk	Vertical
13289.92	28.78	42.60	15.90	38.90	12.20	40.98	54.00	-13.02	AV	Vertical
13282.66	32.95	42.60	15.90	38.90	12.20	45.15	68.20	-23.05	Pk	Horizontal
13282.66	28.72	42.60	15.90	38.90	12.20	40.92	54.00	-13.08	AV	Horizontal

Remark:

- Factor = Antenna Factor + Cable Loss – Pre-amplifier.
- Scan with 802.11a,802.11n (HT-20),802.11n (HT-40), 802.11ac (VHT-20),802.11ac (VHT-40), 802.11ac (VHT-80) the worst case is 802.11a.
- The frequency emission of peak points that did not show above the forms are at least 20dB below the limit, the frequency emission is mainly from the environment noise.



Band II 5250-5350MHz

Frequency (MHz)	Reading	Amplifier	Loss	Antenna Factor	Orrected Factor	Emission Level	Limit (dBuV/m)	Margin	Detector	Comment
	(dBuV)	(dB)	(dB)	(dB/m)	(dB)	(dBuV/m)		(dB)		
Low Channel (802.11a/ 5260 MHz)										
3260.05	44.47	44.70	6.70	28.20	-9.80	34.67	68.20	-33.53	Pk	Vertical
3260.05	41.18	44.70	6.70	28.20	-9.80	31.38	54.00	-22.62	AV	Vertical
3259.19	44.13	44.70	6.70	28.20	-9.80	34.33	68.20	-33.87	Pk	Horizontal
3259.19	41.44	44.70	6.70	28.20	-9.80	31.64	54.00	-22.36	AV	Horizontal
3995.07	39.70	44.20	7.90	29.70	-6.60	33.10	68.20	-35.10	Pk	Vertical
3995.07	35.72	44.20	7.90	29.70	-6.60	29.12	54.00	-24.88	AV	Vertical
3990.25	39.43	44.20	7.90	29.70	-6.60	32.83	68.20	-35.37	Pk	Horizontal
3990.25	35.68	44.20	7.90	29.70	-6.60	29.08	54.00	-24.92	AV	Horizontal
7217.39	36.63	43.50	11.40	35.50	3.40	40.03	68.20	-28.17	Pk	Vertical
7217.39	34.39	43.50	11.40	35.50	3.40	37.79	54.00	-16.21	AV	Vertical
7226.37	37.16	43.50	11.40	35.50	3.40	40.56	68.20	-27.64	Pk	Horizontal
7226.37	34.61	43.50	11.40	35.50	3.40	38.01	54.00	-15.99	AV	Horizontal
10520.14	39.25	44.50	13.90	38.80	8.20	47.45	68.20	-20.75	Pk	Vertical
10520.14	36.02	44.50	13.90	38.80	8.20	44.22	54.00	-9.78	AV	Vertical
10520.24	40.02	44.50	13.90	38.80	8.20	48.22	68.20	-19.98	Pk	Horizontal
10520.24	35.96	44.50	13.90	38.80	8.20	44.16	54.00	-9.84	AV	Horizontal
11017.03	33.11	43.60	14.30	39.50	10.20	43.31	68.20	-24.89	Pk	Vertical
11017.03	30.35	43.60	14.30	39.50	10.20	40.55	54.00	-13.45	AV	Vertical
11027.24	33.28	43.60	14.30	39.50	10.20	43.48	68.20	-24.72	Pk	Horizontal
11027.24	30.16	43.60	14.30	39.50	10.20	40.36	54.00	-13.64	AV	Horizontal
13294.70	32.89	42.60	15.90	38.90	12.20	45.09	68.20	-23.11	Pk	Vertical
13294.70	29.78	42.60	15.90	38.90	12.20	41.98	54.00	-12.02	AV	Vertical
13292.99	31.91	42.60	15.90	38.90	12.20	44.11	68.20	-24.09	Pk	Horizontal
13292.99	29.98	42.60	15.90	38.90	12.20	42.18	54.00	-11.82	AV	Horizontal
Mid Channel (802.11a/ 5300 MHz)										
3265.29	45.15	44.70	6.70	28.20	-9.80	35.35	68.20	-32.85	Pk	Vertical
3265.29	41.05	44.70	6.70	28.20	-9.80	31.25	54.00	-22.75	AV	Vertical
3256.01	44.44	44.70	6.70	28.20	-9.80	34.64	68.20	-33.56	Pk	Horizontal
3256.01	41.28	44.70	6.70	28.20	-9.80	31.48	54.00	-22.52	AV	Horizontal
4000.12	39.98	44.20	7.90	29.70	-6.60	33.38	68.20	-34.82	Pk	Vertical
4000.12	36.99	44.20	7.90	29.70	-6.60	30.39	54.00	-23.61	AV	Vertical
3983.00	39.71	44.20	7.90	29.70	-6.60	33.11	68.20	-35.09	Pk	Horizontal
3983.00	36.79	44.20	7.90	29.70	-6.60	30.19	54.00	-23.81	AV	Horizontal
7229.97	37.15	43.50	11.40	35.50	3.40	40.55	68.20	-27.65	Pk	Vertical
7229.97	33.46	43.50	11.40	35.50	3.40	36.86	54.00	-17.14	AV	Vertical
7230.48	36.51	43.50	11.40	35.50	3.40	39.91	68.20	-28.29	Pk	Horizontal
7230.48	34.14	43.50	11.40	35.50	3.40	37.54	54.00	-16.46	AV	Horizontal
10600.38	39.13	44.50	13.80	38.80	8.10	47.23	68.20	-20.97	Pk	Vertical
10600.38	36.06	44.50	13.80	38.80	8.10	44.16	54.00	-9.84	AV	Vertical
10600.08	38.78	44.50	13.80	38.80	8.10	46.88	68.20	-21.32	Pk	Horizontal
10600.08	36.61	44.50	13.80	38.80	8.10	44.71	54.00	-9.29	AV	Horizontal
11034.46	34.16	43.60	14.30	39.50	10.20	44.36	68.20	-23.84	Pk	Vertical
11034.46	31.03	43.60	14.30	39.50	10.20	41.23	54.00	-12.77	AV	Vertical
11025.83	33.66	43.60	14.30	39.50	10.20	43.86	68.20	-24.34	Pk	Horizontal
11025.83	30.52	43.60	14.30	39.50	10.20	40.72	54.00	-13.28	AV	Horizontal
13295.21	31.72	42.60	15.90	38.90	12.20	43.92	68.20	-24.28	Pk	Vertical
13295.21	29.11	42.60	15.90	38.90	12.20	41.31	54.00	-12.69	AV	Vertical
13296.65	32.89	42.60	15.90	38.90	12.20	45.09	68.20	-23.11	Pk	Horizontal
13296.65	28.73	42.60	15.90	38.90	12.20	40.93	54.00	-13.07	AV	Horizontal



High Channel (802.11a/ 5320 MHz)										
3261.93	43.79	44.70	6.70	28.20	-9.80	33.99	68.20	-34.21	Pk	Vertical
3261.93	41.03	44.70	6.70	28.20	-9.80	31.23	54.00	-22.77	AV	Vertical
3253.49	44.12	44.70	6.70	28.20	-9.80	34.32	68.20	-33.88	Pk	Horizontal
3253.49	42.16	44.70	6.70	28.20	-9.80	32.36	54.00	-21.64	AV	Horizontal
3990.12	38.70	44.20	7.90	29.70	-6.60	32.10	68.20	-36.10	Pk	Vertical
3990.12	36.99	44.20	7.90	29.70	-6.60	30.39	54.00	-23.61	AV	Vertical
3997.77	38.74	44.20	7.90	29.70	-6.60	32.14	68.20	-36.06	Pk	Horizontal
3997.77	36.35	44.20	7.90	29.70	-6.60	29.75	54.00	-24.25	AV	Horizontal
7225.95	37.20	43.50	11.40	35.50	3.40	40.60	68.20	-27.60	Pk	Vertical
7225.95	33.49	43.50	11.40	35.50	3.40	36.89	54.00	-17.11	AV	Vertical
7225.84	37.05	43.50	11.40	35.50	3.40	40.45	68.20	-27.75	Pk	Horizontal
7225.84	33.47	43.50	11.40	35.50	3.40	36.87	54.00	-17.13	AV	Horizontal
10639.96	39.19	44.50	13.80	38.80	8.10	47.29	68.20	-20.91	Pk	Vertical
10639.96	36.11	44.50	13.80	38.80	8.10	44.21	54.00	-9.79	AV	Vertical
10640.31	39.71	44.50	13.80	38.80	8.10	47.81	68.20	-20.39	Pk	Horizontal
10640.31	36.31	44.50	13.80	38.80	8.10	44.41	54.00	-9.59	AV	Horizontal
11019.83	32.72	43.60	14.30	39.50	10.20	42.92	68.20	-25.28	Pk	Vertical
11019.83	30.18	43.60	14.30	39.50	10.20	40.38	54.00	-13.62	AV	Vertical
11016.64	32.69	43.60	14.30	39.50	10.20	42.89	68.20	-25.31	Pk	Horizontal
11016.64	29.71	43.60	14.30	39.50	10.20	39.91	54.00	-14.09	AV	Horizontal
13285.38	32.20	42.70	18.00	37.10	12.40	44.60	68.20	-23.60	Pk	Vertical
13285.38	29.94	42.70	18.00	37.10	12.40	42.34	54.00	-11.66	AV	Vertical
13285.08	32.99	42.70	18.00	37.10	12.40	45.39	68.20	-22.81	Pk	Horizontal
13285.08	29.60	42.70	18.00	37.10	12.40	42.00	54.00	-12.00	AV	Horizontal

Remark:

- Factor = Antenna Factor + Cable Loss – Pre-amplifier.
- Scan with 802.11a,802.11n (HT-20),802.11n (HT-40), 802.11ac (VHT-20),802.11ac (VHT-40), 802.11ac (VHT-80) the worst case is 802.11a.
- The frequency emission of peak points that did not show above the forms are at least 20dB below the limit, the frequency emission is mainly from the environment noise.



Band III 5470-5725MHz

Frequency (MHz)	Reading	Amplifier	Loss	Antenna Factor	Orrected Factor	Emission Level	Limit (dBuV/m)	Margin	Detector	Comment
	(dBuV)	(dB)	(dB)	(dB/m)	(dB)	(dBuV/m)		(dB)		
Low Channel (802.11a/ 5500 MHz)										
3248.02	44.46	44.70	6.70	28.20	-9.80	34.66	68.20	-33.54	Pk	Vertical
3248.02	42.04	44.70	6.70	28.20	-9.80	32.24	54.00	-21.76	AV	Vertical
3252.62	44.27	44.70	6.70	28.20	-9.80	34.47	68.20	-33.73	Pk	Horizontal
3252.62	41.16	44.70	6.70	28.20	-9.80	31.36	54.00	-22.64	AV	Horizontal
3992.01	38.99	44.20	7.90	29.70	-6.60	32.39	68.20	-35.81	Pk	Vertical
3992.01	36.24	44.20	7.90	29.70	-6.60	29.64	54.00	-24.36	AV	Vertical
3990.52	38.97	44.20	7.90	29.70	-6.60	32.37	68.20	-35.83	Pk	Horizontal
3990.52	36.66	44.20	7.90	29.70	-6.60	30.06	54.00	-23.94	AV	Horizontal
7229.59	37.00	43.50	11.40	35.50	3.40	40.40	68.20	-27.80	Pk	Vertical
7229.59	34.77	43.50	11.40	35.50	3.40	38.17	54.00	-15.83	AV	Vertical
7234.59	37.23	43.50	11.40	35.50	3.40	40.63	68.20	-27.57	Pk	Horizontal
7234.59	34.29	43.50	11.40	35.50	3.40	37.69	54.00	-16.31	AV	Horizontal
10359.33	39.19	44.50	13.80	38.80	8.10	47.29	68.20	-20.91	Pk	Vertical
10359.33	36.57	44.50	13.80	38.80	8.10	44.67	54.00	-9.33	AV	Vertical
10342.07	40.03	44.50	13.80	38.80	8.10	48.13	68.20	-20.07	Pk	Horizontal
10342.07	36.06	44.50	13.80	38.80	8.10	44.16	54.00	-9.84	AV	Horizontal
11000.10	32.71	43.60	14.30	39.50	10.20	42.91	68.20	-25.29	Pk	Vertical
11000.10	30.31	43.60	14.30	39.50	10.20	40.51	54.00	-13.49	AV	Vertical
11000.32	32.76	43.60	14.30	39.50	10.20	42.96	68.20	-25.24	Pk	Horizontal
11000.32	30.54	43.60	14.30	39.50	10.20	40.74	54.00	-13.26	AV	Horizontal
13295.45	32.71	42.60	15.90	38.90	12.20	44.91	68.20	-23.29	Pk	Vertical
13295.45	29.38	42.60	15.90	38.90	12.20	41.58	54.00	-12.42	AV	Vertical
13291.88	32.34	42.60	15.90	38.90	12.20	44.54	68.20	-23.66	Pk	Horizontal
13291.88	29.84	42.60	15.90	38.90	12.20	42.04	54.00	-11.96	AV	Horizontal
Mid Channel (802.11a/ 5580 MHz)										
3261.67	43.76	44.70	6.70	28.20	-9.80	33.96	68.20	-34.24	Pk	Vertical
3261.67	40.89	44.70	6.70	28.20	-9.80	31.09	54.00	-22.91	AV	Vertical
3246.52	44.78	44.70	6.70	28.20	-9.80	34.98	68.20	-33.22	Pk	Horizontal
3246.52	42.21	44.70	6.70	28.20	-9.80	32.41	54.00	-21.59	AV	Horizontal
3993.22	38.95	44.20	7.90	29.70	-6.60	32.35	68.20	-35.85	Pk	Vertical
3993.22	36.93	44.20	7.90	29.70	-6.60	30.33	54.00	-23.67	AV	Vertical
3988.91	39.00	44.20	7.90	29.70	-6.60	32.40	68.20	-35.80	Pk	Horizontal
3988.91	36.13	44.20	7.90	29.70	-6.60	29.53	54.00	-24.47	AV	Horizontal
7232.11	37.12	43.50	11.40	35.50	3.40	40.52	68.20	-27.68	Pk	Vertical
7232.11	33.73	43.50	11.40	35.50	3.40	37.13	54.00	-16.87	AV	Vertical
7231.02	36.59	43.50	11.40	35.50	3.40	39.99	68.20	-28.21	Pk	Horizontal
7231.02	33.79	43.50	11.40	35.50	3.40	37.19	54.00	-16.81	AV	Horizontal
10392.79	39.04	44.50	13.80	38.80	8.10	47.14	68.20	-21.06	Pk	Vertical
10392.79	35.94	44.50	13.80	38.80	8.10	44.04	54.00	-9.96	AV	Vertical
10385.74	39.77	44.50	13.80	38.80	8.10	47.87	68.20	-20.33	Pk	Horizontal
10385.74	36.86	44.50	13.80	38.80	8.10	44.96	54.00	-9.04	AV	Horizontal
11160.21	33.92	43.60	14.30	39.50	10.20	44.12	68.20	-24.08	Pk	Vertical
11160.21	30.42	43.60	14.30	39.50	10.20	40.62	54.00	-13.38	AV	Vertical
11160.29	33.12	43.60	14.30	39.50	10.20	43.32	68.20	-24.88	Pk	Horizontal
11160.29	30.92	43.60	14.30	39.50	10.20	41.12	54.00	-12.88	AV	Horizontal
13294.67	31.64	42.60	15.90	38.90	12.20	43.84	68.20	-24.36	Pk	Vertical
13294.67	29.50	42.60	15.90	38.90	12.20	41.70	54.00	-12.30	AV	Vertical
13281.41	32.21	42.60	15.90	38.90	12.20	44.41	68.20	-23.79	Pk	Horizontal
13281.41	29.24	42.60	15.90	38.90	12.20	41.44	54.00	-12.56	AV	Horizontal



High Channel (802.11a/ 5700 MHz)										
3253.63	44.49	44.70	6.70	28.20	-9.80	34.69	68.20	-33.51	Pk	Vertical
3253.63	41.06	44.70	6.70	28.20	-9.80	31.26	54.00	-22.74	AV	Vertical
3260.05	44.72	44.70	6.70	28.20	-9.80	34.92	68.20	-33.28	Pk	Horizontal
3260.05	41.54	44.70	6.70	28.20	-9.80	31.74	54.00	-22.26	AV	Horizontal
3985.26	39.30	44.20	7.90	29.70	-6.60	32.70	68.20	-35.50	Pk	Vertical
3985.26	37.14	44.20	7.90	29.70	-6.60	30.54	54.00	-23.46	AV	Vertical
3985.43	39.29	44.20	7.90	29.70	-6.60	32.69	68.20	-35.51	Pk	Horizontal
3985.43	36.48	44.20	7.90	29.70	-6.60	29.88	54.00	-24.12	AV	Horizontal
7228.43	36.52	43.50	11.40	35.50	3.40	39.92	68.20	-28.28	Pk	Vertical
7228.43	33.66	43.50	11.40	35.50	3.40	37.06	54.00	-16.94	AV	Vertical
7224.07	37.56	43.50	11.40	35.50	3.40	40.96	68.20	-27.24	Pk	Horizontal
7224.07	34.31	43.50	11.40	35.50	3.40	37.71	54.00	-16.29	AV	Horizontal
10461.90	39.12	44.50	13.80	38.80	8.10	47.22	68.20	-20.98	Pk	Vertical
10461.90	36.74	44.50	13.80	38.80	8.10	44.84	54.00	-9.16	AV	Vertical
10467.80	40.08	44.50	13.80	38.80	8.10	48.18	68.20	-20.02	Pk	Horizontal
10467.80	36.96	44.50	13.80	38.80	8.10	45.06	54.00	-8.94	AV	Horizontal
11399.94	33.70	43.60	14.30	39.50	10.20	43.90	68.20	-24.30	Pk	Vertical
11399.94	30.82	43.60	14.30	39.50	10.20	41.02	54.00	-12.98	AV	Vertical
11400.04	33.06	43.60	14.30	39.50	10.20	43.26	68.20	-24.94	Pk	Horizontal
11400.04	29.88	43.60	14.30	39.50	10.20	40.08	54.00	-13.92	AV	Horizontal
13284.44	32.49	42.60	15.90	38.90	12.20	44.69	68.20	-23.51	Pk	Vertical
13284.44	29.71	42.60	15.90	38.90	12.20	41.91	54.00	-12.09	AV	Vertical
13286.90	32.42	42.60	15.90	38.90	12.20	44.62	68.20	-23.58	Pk	Horizontal
13286.90	29.41	42.60	15.90	38.90	12.20	41.61	54.00	-12.39	AV	Horizontal

Remark:

- Factor = Antenna Factor + Cable Loss – Pre-amplifier.
- Scan with 802.11a,802.11n (HT-20),802.11n (HT-40), 802.11ac (VHT-20),802.11ac (VHT-40), 802.11ac (VHT-80) the worst case is 802.11a.
- The frequency emission of peak points that did not show above the forms are at least 20dB below the limit, the frequency emission is mainly from the environment noise.



Band IV(5.725-5.850) GHz

Frequency (MHz)	Reading	Amplifier	Loss	Antenna Factor	Orrected Factor	Emission Level	Limit (dBuV/m)	Margin	Detector	Comment
	(dBuV)	(dB)	(dB)	(dB/m)	(dB)	(dBuV/m)		(dB)		
Low Channel (802.11a/ 5745 MHz)										
3258.37	45.06	44.70	6.70	28.20	-9.80	35.26	68.20	-32.94	Pk	Vertical
3258.37	40.86	44.70	6.70	28.20	-9.80	31.06	54.00	-22.94	AV	Vertical
3257.00	44.98	44.70	6.70	28.20	-9.80	35.18	68.20	-33.02	Pk	Horizontal
3257.00	40.75	44.70	6.70	28.20	-9.80	30.95	54.00	-23.05	AV	Horizontal
3992.58	39.49	44.20	7.90	29.70	-6.60	32.89	68.20	-35.31	Pk	Vertical
3992.58	35.90	44.20	7.90	29.70	-6.60	29.30	54.00	-24.70	AV	Vertical
3986.43	38.76	44.20	7.90	29.70	-6.60	32.16	68.20	-36.04	Pk	Horizontal
3986.43	36.48	44.20	7.90	29.70	-6.60	29.88	54.00	-24.12	AV	Horizontal
7228.65	37.18	43.50	11.40	35.50	3.40	40.58	68.20	-27.62	Pk	Vertical
7228.65	33.96	43.50	11.40	35.50	3.40	37.36	54.00	-16.64	AV	Vertical
7231.96	37.10	43.50	11.40	35.50	3.40	40.50	68.20	-27.70	Pk	Horizontal
7231.96	34.51	43.50	11.40	35.50	3.40	37.91	54.00	-16.09	AV	Horizontal
10504.84	39.87	44.50	13.90	38.80	8.20	48.07	68.20	-20.13	Pk	Vertical
10504.84	36.31	44.50	13.90	38.80	8.20	44.51	54.00	-9.49	AV	Vertical
10503.38	38.72	44.50	13.90	38.80	8.20	46.92	68.20	-21.28	Pk	Horizontal
10503.38	36.03	44.50	13.90	38.80	8.20	44.23	54.00	-9.77	AV	Horizontal
11490.29	33.06	43.60	14.30	39.50	10.20	43.26	68.20	-24.94	Pk	Vertical
11490.29	30.11	43.60	14.30	39.50	10.20	40.31	54.00	-13.69	AV	Vertical
11490.03	34.03	43.60	14.30	39.50	10.20	44.23	68.20	-23.97	Pk	Horizontal
11490.03	29.81	43.60	14.30	39.50	10.20	40.01	54.00	-13.99	AV	Horizontal
13296.63	32.46	42.60	15.90	38.90	12.20	44.66	68.20	-23.54	Pk	Vertical
13296.63	28.73	42.60	15.90	38.90	12.20	40.93	54.00	-13.07	AV	Vertical
13295.17	32.06	42.60	15.90	38.90	12.20	44.26	68.20	-23.94	Pk	Horizontal
13295.17	29.74	42.60	15.90	38.90	12.20	41.94	54.00	-12.06	AV	Horizontal
Mid Channel (802.11a/ 5785 MHz)										
3264.29	44.84	44.70	6.70	28.20	-9.80	35.04	68.20	-33.16	Pk	Vertical
3264.29	40.74	44.70	6.70	28.20	-9.80	30.94	54.00	-23.06	AV	Vertical
3245.69	45.17	44.70	6.70	28.20	-9.80	35.37	68.20	-32.83	Pk	Horizontal
3245.69	41.49	44.70	6.70	28.20	-9.80	31.69	54.00	-22.31	AV	Horizontal
3989.90	38.93	44.20	7.90	29.70	-6.60	32.33	68.20	-35.87	Pk	Vertical
3989.90	36.42	44.20	7.90	29.70	-6.60	29.82	54.00	-24.18	AV	Vertical
3999.44	39.08	44.20	7.90	29.70	-6.60	32.48	68.20	-35.72	Pk	Horizontal
3999.44	36.56	44.20	7.90	29.70	-6.60	29.96	54.00	-24.04	AV	Horizontal
7234.24	37.33	43.50	11.40	35.50	3.40	40.73	68.20	-27.47	Pk	Vertical
7234.24	34.11	43.50	11.40	35.50	3.40	37.51	54.00	-16.49	AV	Vertical
7230.66	36.51	43.50	11.40	35.50	3.40	39.91	68.20	-28.29	Pk	Horizontal
7230.66	34.56	43.50	11.40	35.50	3.40	37.96	54.00	-16.04	AV	Horizontal
10597.42	38.72	44.50	13.80	38.80	8.10	46.82	68.20	-21.38	Pk	Vertical
10597.42	35.70	44.50	13.80	38.80	8.10	43.80	54.00	-10.20	AV	Vertical
10594.50	39.42	44.50	13.80	38.80	8.10	47.52	68.20	-20.68	Pk	Horizontal
10594.50	35.91	44.50	13.80	38.80	8.10	44.01	54.00	-9.99	AV	Horizontal
11570.01	33.82	43.60	14.30	39.50	10.20	44.02	68.20	-24.18	Pk	Vertical
11570.01	31.09	43.60	14.30	39.50	10.20	41.29	54.00	-12.71	AV	Vertical
11570.04	33.21	43.60	14.30	39.50	10.20	43.41	68.20	-24.79	Pk	Horizontal
11570.04	29.73	43.60	14.30	39.50	10.20	39.93	54.00	-14.07	AV	Horizontal
13290.52	32.74	42.60	15.90	38.90	12.20	44.94	68.20	-23.26	Pk	Vertical
13290.52	28.56	42.60	15.90	38.90	12.20	40.76	54.00	-13.24	AV	Vertical
13283.45	32.38	42.60	15.90	38.90	12.20	44.58	68.20	-23.62	Pk	Horizontal
13283.45	29.07	42.60	15.90	38.90	12.20	41.27	54.00	-12.73	AV	Horizontal



High Channel (802.11a/ 5825 MHz)										
3246.04	44.81	44.70	6.70	28.20	-9.80	35.01	68.20	-33.19	Pk	Vertical
3246.04	42.17	44.70	6.70	28.20	-9.80	32.37	54.00	-21.63	AV	Vertical
3260.80	45.15	44.70	6.70	28.20	-9.80	35.35	68.20	-32.85	Pk	Horizontal
3260.80	41.31	44.70	6.70	28.20	-9.80	31.51	54.00	-22.49	AV	Horizontal
3999.05	39.72	44.20	7.90	29.70	-6.60	33.12	68.20	-35.08	Pk	Vertical
3999.05	35.71	44.20	7.90	29.70	-6.60	29.11	54.00	-24.89	AV	Vertical
3999.46	39.64	44.20	7.90	29.70	-6.60	33.04	68.20	-35.16	Pk	Horizontal
3999.46	36.88	44.20	7.90	29.70	-6.60	30.28	54.00	-23.72	AV	Horizontal
7221.35	36.78	43.50	11.40	35.50	3.40	40.18	68.20	-28.02	Pk	Vertical
7221.35	34.17	43.50	11.40	35.50	3.40	37.57	54.00	-16.43	AV	Vertical
7234.42	36.59	43.50	11.40	35.50	3.40	39.99	68.20	-28.21	Pk	Horizontal
7234.42	33.51	43.50	11.40	35.50	3.40	36.91	54.00	-17.09	AV	Horizontal
10626.48	38.97	44.50	13.80	38.80	8.10	47.07	68.20	-21.13	Pk	Vertical
10626.48	35.69	44.50	13.80	38.80	8.10	43.79	54.00	-10.21	AV	Vertical
10640.40	39.33	44.50	13.80	38.80	8.10	47.43	68.20	-20.77	Pk	Horizontal
10640.40	36.45	44.50	13.80	38.80	8.10	44.55	54.00	-9.45	AV	Horizontal
11650.02	33.75	43.60	14.30	39.50	10.20	43.95	68.20	-24.25	Pk	Vertical
11650.02	30.67	43.60	14.30	39.50	10.20	40.87	54.00	-13.13	AV	Vertical
11650.23	33.69	43.60	14.30	39.50	10.20	43.89	68.20	-24.31	Pk	Horizontal
11650.23	30.90	43.60	14.30	39.50	10.20	41.10	54.00	-12.90	AV	Horizontal
13298.57	32.51	42.70	18.00	37.10	12.40	44.91	68.20	-23.29	Pk	Vertical
13298.57	29.13	42.70	18.00	37.10	12.40	41.53	54.00	-12.47	AV	Vertical
13299.06	31.79	42.70	18.00	37.10	12.40	44.19	68.20	-24.01	Pk	Horizontal
13299.06	29.58	42.70	18.00	37.10	12.40	41.98	54.00	-12.02	AV	Horizontal

Remark:

- Factor = Antenna Factor + Cable Loss – Pre-amplifier.
- Scan with 802.11a,802.11n (HT-20),802.11n (HT-40), 802.11ac (VHT-20),802.11ac (VHT-40), 802.11ac (VHT-80) the worst case is 802.11a.
- The frequency emission of peak points that did not show above the forms are at least 20dB below the limit, the frequency emission is mainly from the environment noise.



3.2.9 Band Edge
Band I 5150-5250MHz

802.11a Low
Horizontal

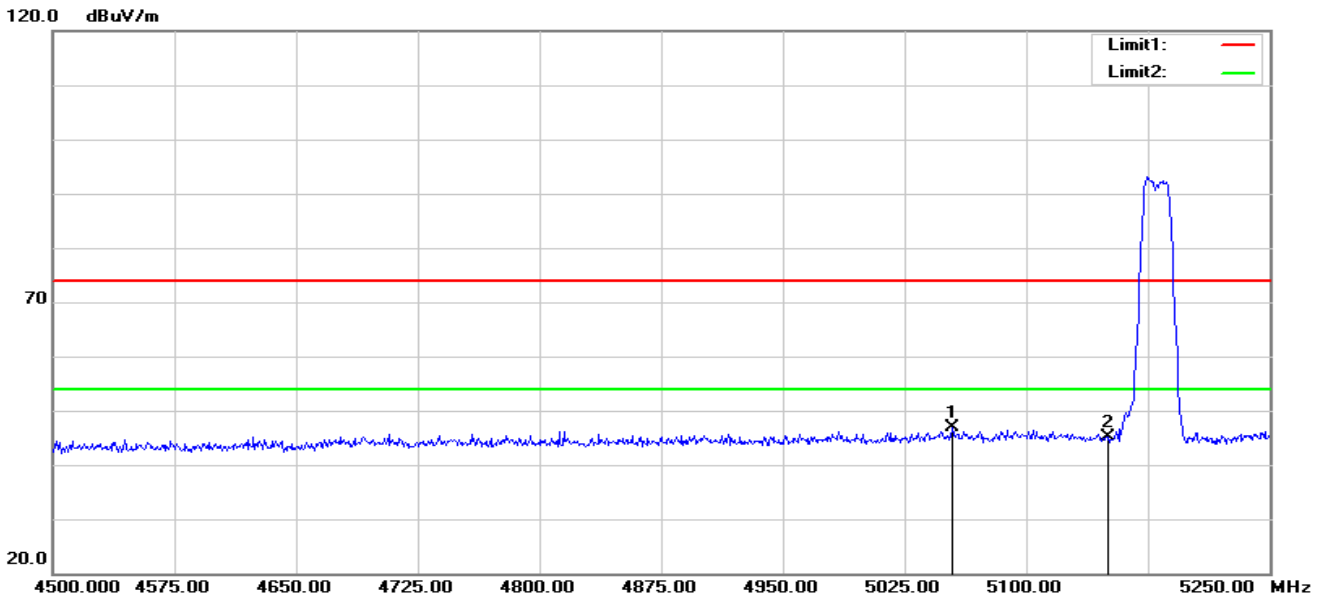

No.	Frequency (MHz)	Reading (dBuV)	Correct Factor(dB/m)	Result (dBuV/m)	Limit (dBuV/m)	Margin (dB)	Remark
1	5054.250	52.72	-5.95	46.77	74.00	-27.23	peak
2	5150.000	50.76	-5.73	45.03	74.00	-28.97	peak

Vertical

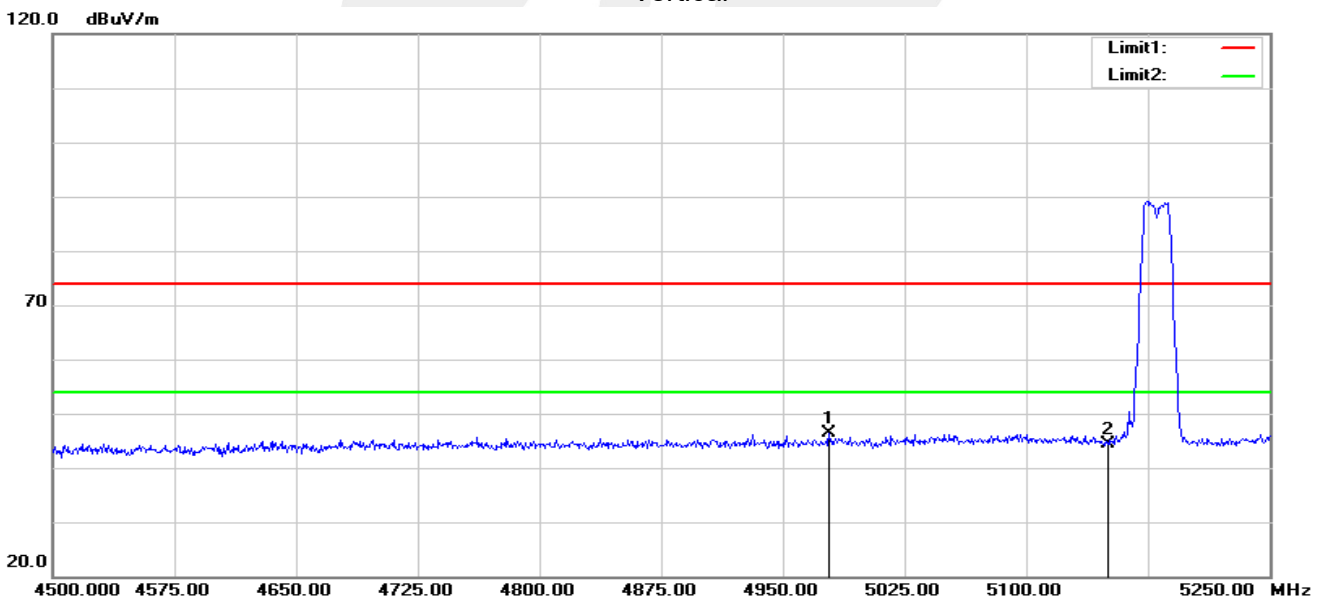

No.	Frequency (MHz)	Reading (dBuV)	Correct Factor(dB/m)	Result (dBuV/m)	Limit (dBuV/m)	Margin (dB)	Remark
1	4978.500	52.61	-6.33	46.28	74.00	-27.72	peak
2	5150.000	49.99	-5.73	44.26	74.00	-29.74	peak



802.11a High
Horizontal

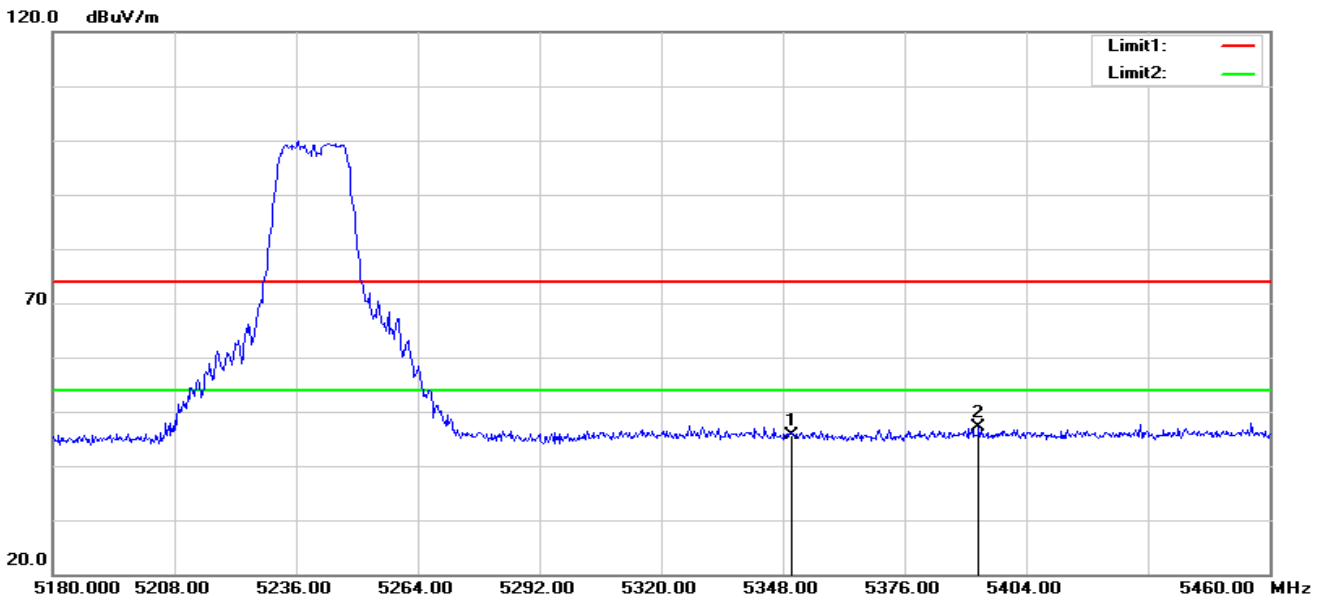

No.	Frequency (MHz)	Reading (dBuV)	Correct Factor(dB/m)	Result (dBuV/m)	Limit (dBuV/m)	Margin (dB)	Remark
1	5350.000	50.83	-5.23	45.60	74.00	-28.40	peak
2	5393.080	52.43	-5.25	47.18	74.00	-26.82	peak

Vertical

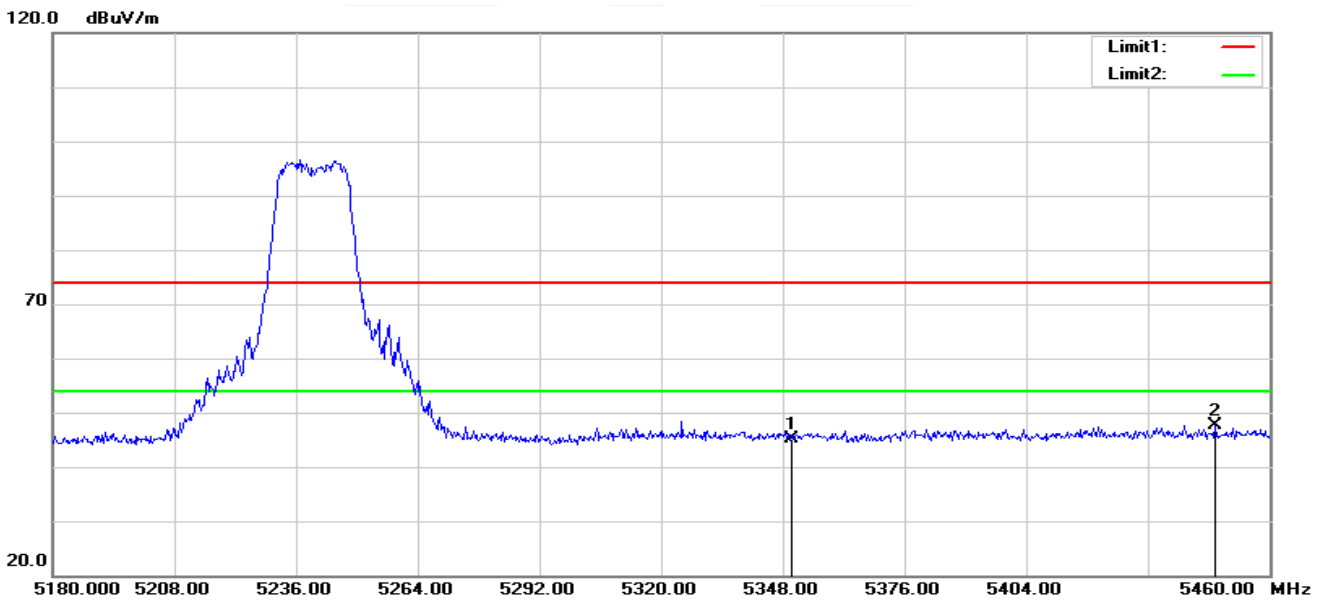

No.	Frequency (MHz)	Reading (dBuV)	Correct Factor(dB/m)	Result (dBuV/m)	Limit (dBuV/m)	Margin (dB)	Remark
1	5350.000	50.44	-5.23	45.21	74.00	-28.79	peak
2	5447.400	52.72	-5.14	47.58	74.00	-26.42	peak

Note: 802.11a,802.11n (HT-20),802.11n (HT-40), 802.11ac (VHT-20),802.11ac (VHT-40), 802.11ac (VHT-80) all has been tested, the worst case is 802.11a,only shown the worst case.



Band II 5250-5350MHz

802.11a Low
Horizontal

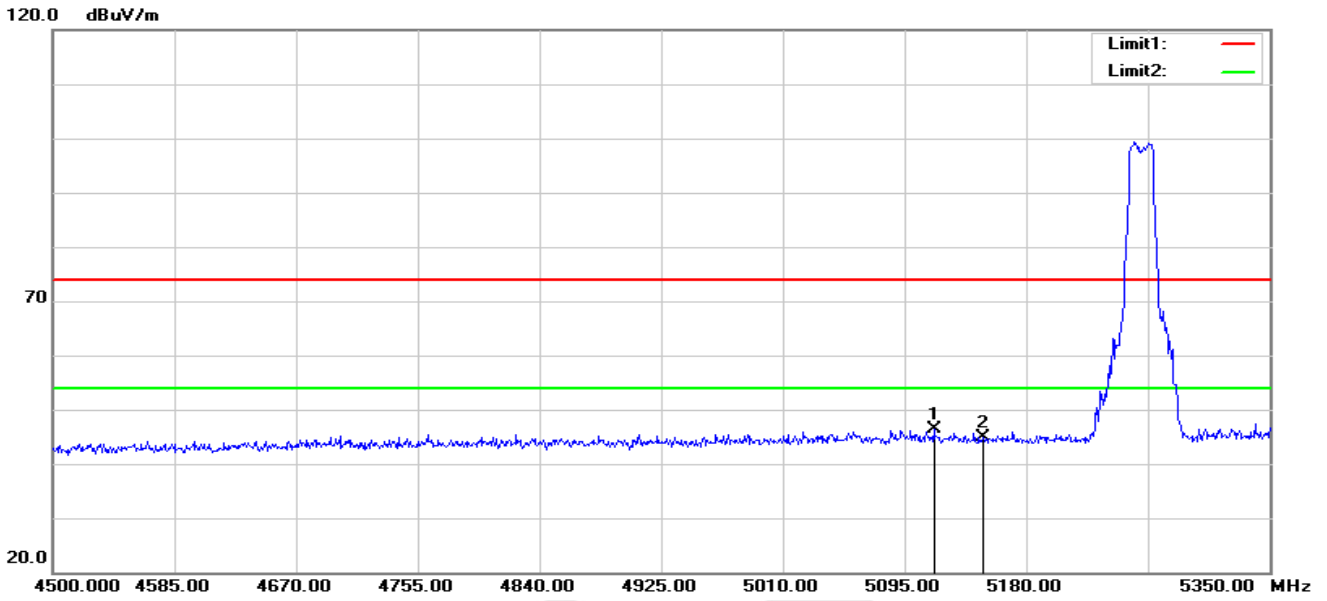

No.	Frequency (MHz)	Reading (dBuV)	Correct Factor(dB/m)	Result (dBuV/m)	Limit (dBuV/m)	Margin (dB)	Remark
1	5115.400	52.17	-5.74	46.43	74.00	-27.57	peak
2	5150.000	50.72	-5.73	44.99	74.00	-29.01	peak

Vertical

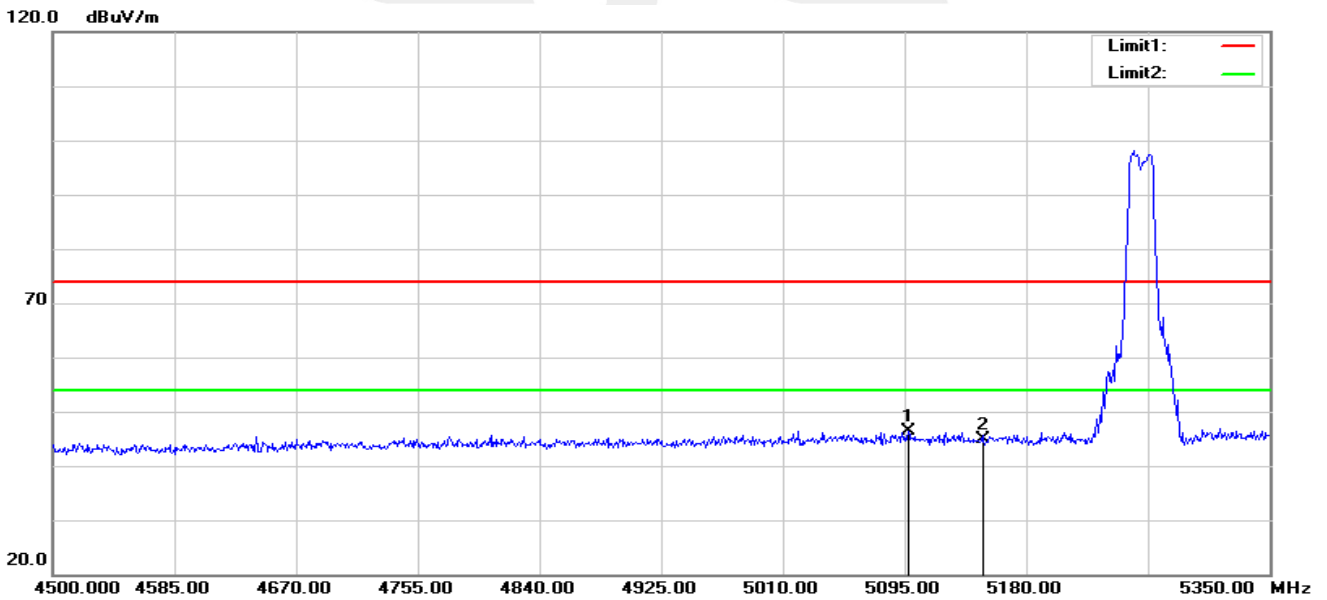

No.	Frequency (MHz)	Reading (dBuV)	Correct Factor(dB/m)	Result (dBuV/m)	Limit (dBuV/m)	Margin (dB)	Remark
1	5097.550	52.13	-5.75	46.38	74.00	-27.62	peak
2	5150.000	50.61	-5.73	44.88	74.00	-29.12	peak



802.11a High Horizontal

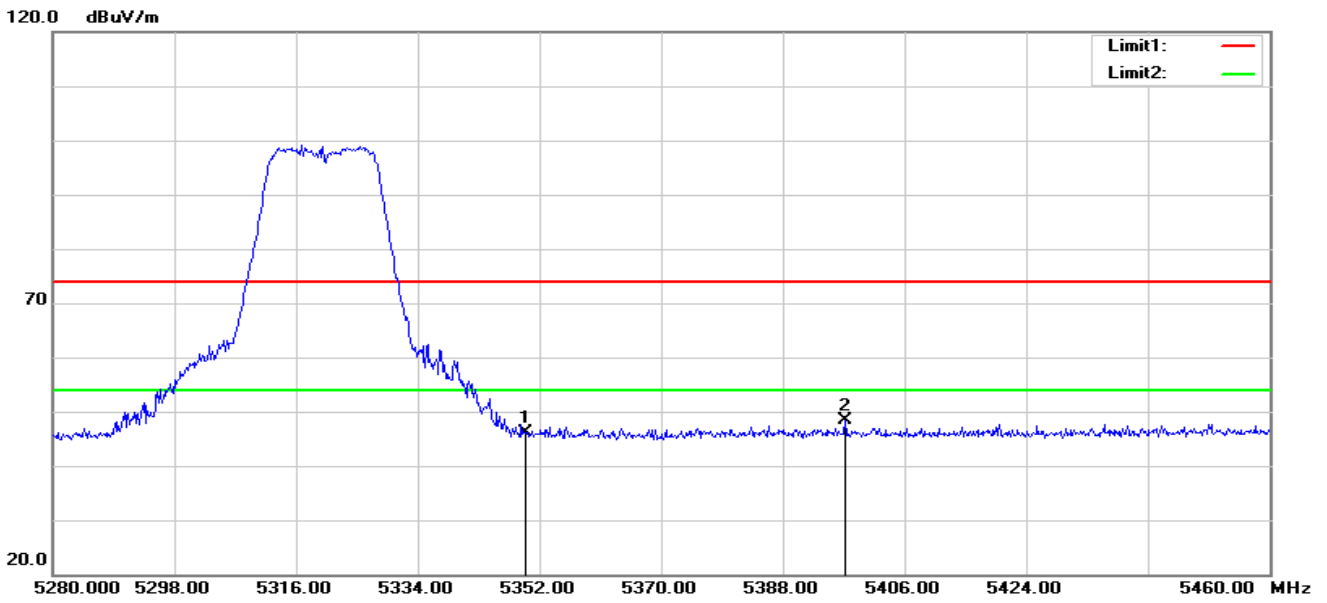

No.	Frequency (MHz)	Reading (dBuV)	Correct Factor(dB/m)	Result (dBuV/m)	Limit (dBuV/m)	Margin (dB)	Remark
1	5350.000	51.31	-5.23	46.08	74.00	-27.92	peak
2	5397.180	53.61	-5.25	48.36	74.00	-25.64	peak

Vertical

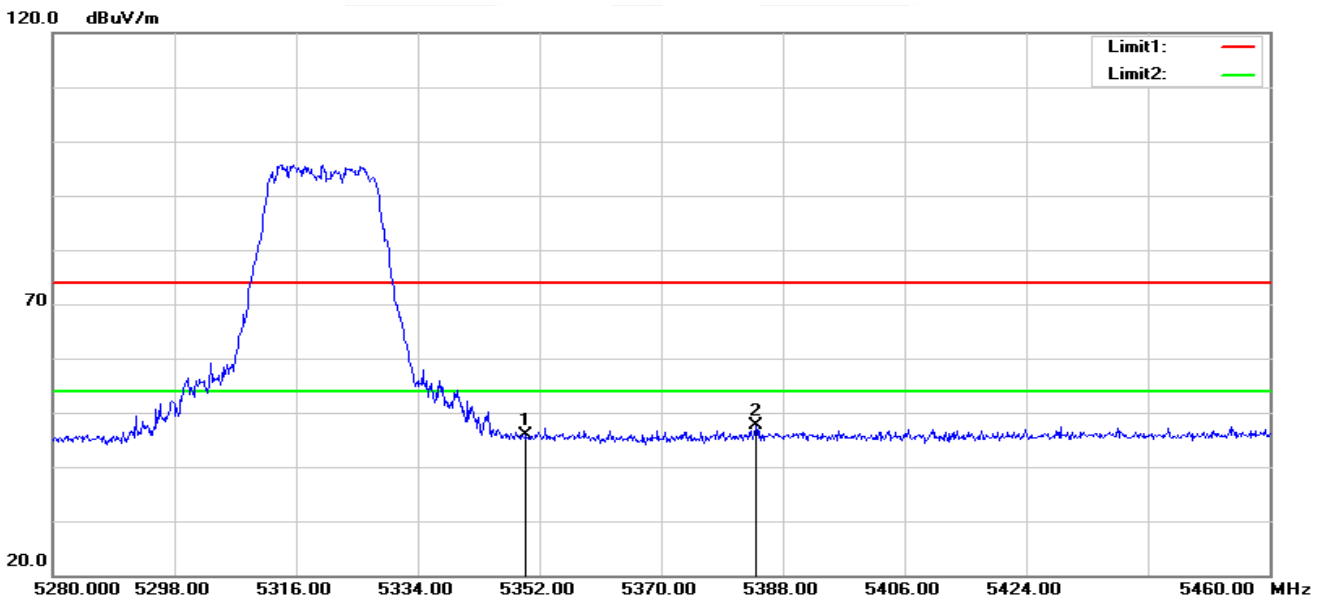

No.	Frequency (MHz)	Reading (dBuV)	Correct Factor(dB/m)	Result (dBuV/m)	Limit (dBuV/m)	Margin (dB)	Remark
1	5350.000	51.17	-5.23	45.94	74.00	-28.06	peak
2	5384.040	52.96	-5.24	47.72	74.00	-26.28	peak

Note: 802.11a,802.11n (HT-20),802.11n (HT-40), 802.11ac (VHT-20),802.11ac (VHT-40), 802.11ac (VHT-80) all has been tested, the worst case is 802.11a,only shown the worst case.



Band III 5470-5725MHz

**802.11a Low
Horizontal**

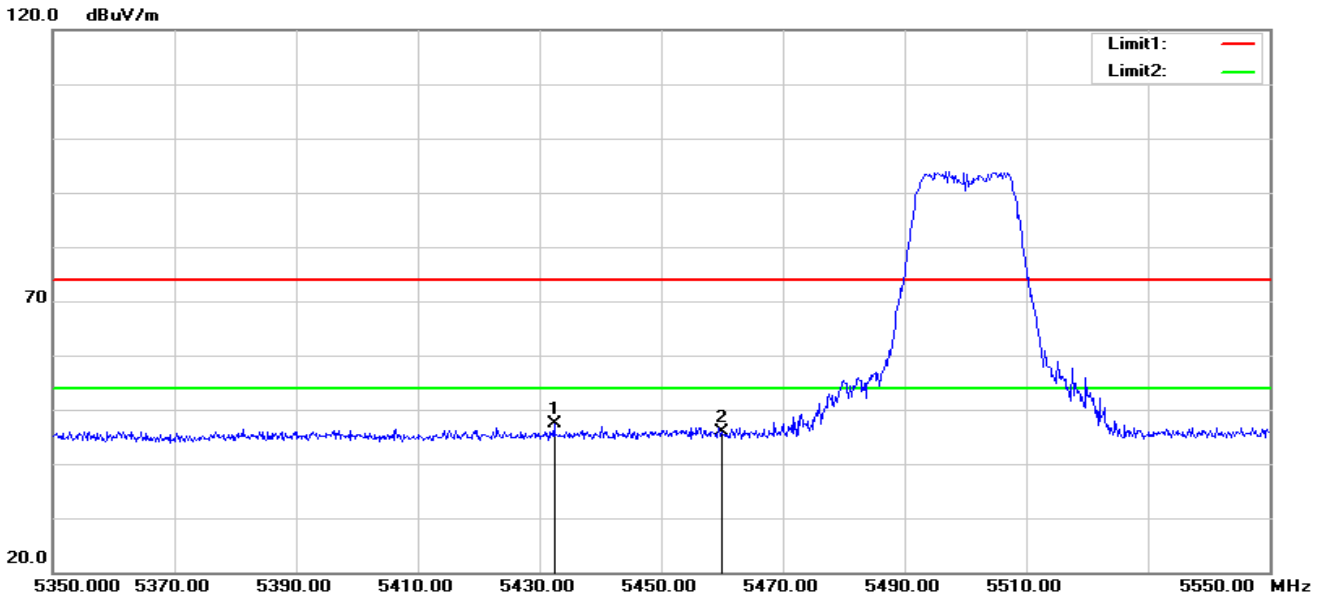

No.	Frequency (MHz)	Reading (dBuV)	Correct Factor(dB/m)	Result (dBuV/m)	Limit (dBuV/m)	Margin (dB)	Remark
1	5432.400	52.57	-5.17	47.40	74.00	-26.60	peak
2	5460.000	50.96	-5.11	45.85	74.00	-28.15	peak

Vertical

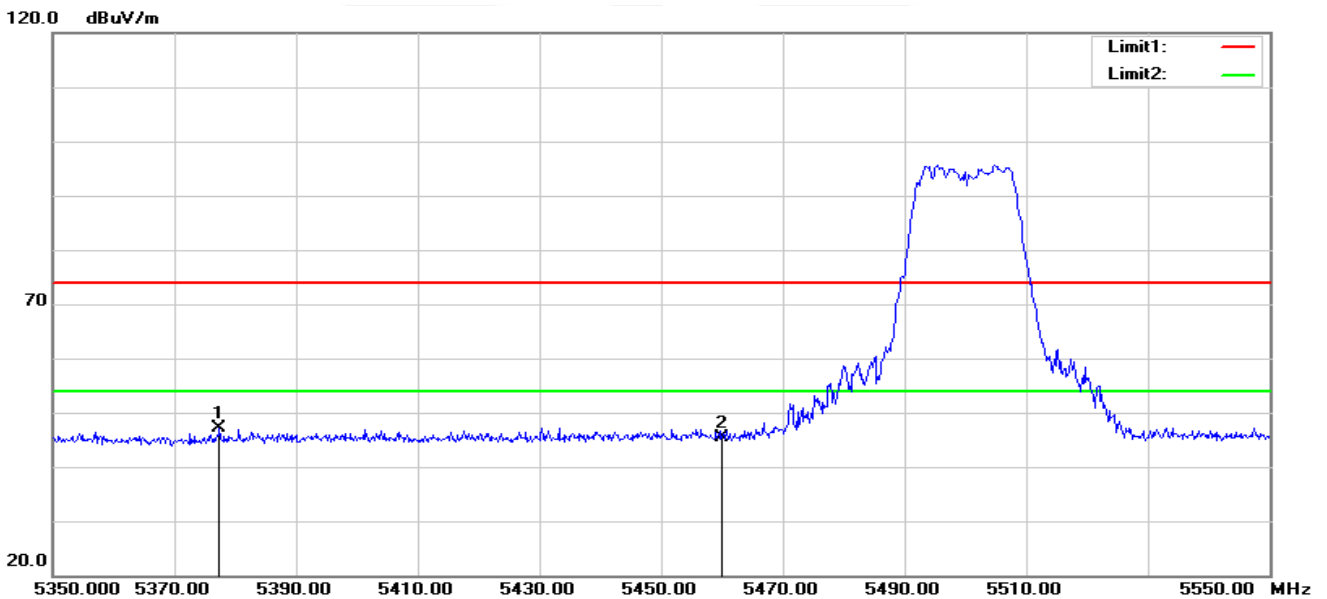

No.	Frequency (MHz)	Reading (dBuV)	Correct Factor(dB/m)	Result (dBuV/m)	Limit (dBuV/m)	Margin (dB)	Remark
1	5377.400	52.42	-5.24	47.18	74.00	-26.82	peak
2	5460.000	50.40	-5.11	45.29	74.00	-28.71	peak

Note: 1. 802.11a,802.11n (HT-20),802.11n (HT-40), 802.11ac (VHT-20),802.11ac (VHT-40), 802.11ac (VHT-80) all has been tested, the worst case is 802.11a,only shown the worst case.
2. The high channel main frequency is too far away from the restricted band and does not require testing.

Band IV(5.725-5.85 GHz)

Note: The main frequency is too far away from the restricted band and does not require testing.

4. CONDUCTED SPURIOUS EMISSIONS AND BANDEDGE

4.1 LIMIT

Undesirable emission limits. Except as shown in paragraph (b)(7) of this section, the maximum emissions outside of the frequency bands of operation shall be attenuated in accordance with the following limits:

- (1) For transmitters operating in the 5.15-5.25 GHz band: All emissions outside of the 5.15-5.35 GHz band shall not exceed an e.i.r.p. of -27 dBm/MHz.
- (2) For transmitters operating in the 5.25-5.35 GHz band: All emissions outside of the 5.15-5.35 GHz band shall not exceed an e.i.r.p. of -27 dBm/MHz.
- (3) For transmitters operating in the 5.47-5.725 GHz band: All emissions outside of the 5.47-5.725 GHz band shall not exceed an e.i.r.p. of -27 dBm/MHz.
- (4) For transmitters operating in the 5.725-5.85 GHz band:
 - (i) All emissions shall be limited to a level of -27 dBm/MHz at 75 MHz or more above or below the band edge increasing linearly to 10 dBm/MHz at 25 MHz above or below the band edge, and from 25 MHz above or below the band edge increasing linearly to a level of 15.6 dBm/MHz at 5 MHz above or below the band edge, and from 5 MHz above or below the band edge increasing linearly to a level of 27 dBm/MHz at the band edge.

4.2 TEST PROCEDURE

Spectrum Parameter	Setting
Detector	Peak
Start/Stop Frequency	30 MHz to 10th carrier harmonic
RB / VB (emission in restricted band)	1000 KHz/3000 KHz
Trace-Mode:	Max hold

For Band edge

Spectrum Parameter	Setting
Detector	Peak
Start/Stop Frequency	Lower Band Edge: 5700 to 5725 MHz Upper Band Edge: 5850 to 5870 MHz
RB / VB (emission in restricted band)	1000 KHz/3000 KHz
Trace-Mode:	Max hold

4.3 DEVIATION FROM STANDARD

No deviation.

4.4 TEST SETUP

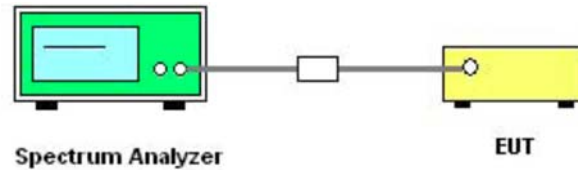

The EUT which is powered by the Battery, is coupled to the Spectrum Analyzer; the RF load attached to the EUT antenna terminal is 50Ohm; the path loss as the factor is calibrated to correct the reading.

Make the measurement with the spectrum analyzer's resolution bandwidth (RBW) = 1000 kHz. In order to make an accurate measurement, set the span greater than RBW.

4.5 EUT OPERATION CONDITIONS

The EUT tested system was configured as the statements of 2.3 Unless otherwise a special operating condition is specified in the follows during the testing.

4.6 TEST RESULTS

Note:

1. Antenna B Power > Antenna A Power, Both antenna A and B have been test, Only show the worst data of Antenna B.
2. Data See Attachment A

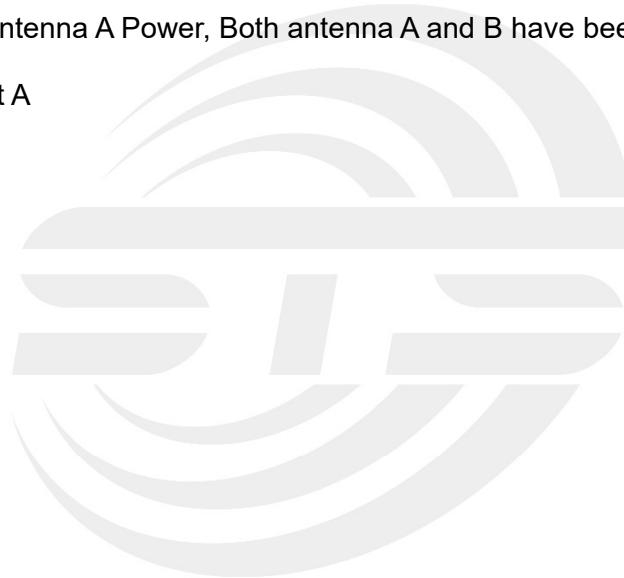



5. POWER SPECTRAL DENSITY TEST

5.1 LIMIT

FCC:

1. For mobile and portable client devices in the 5.15-5.25 GHz band, , the maximum power spectral density shall not exceed 11 dBm in any 1 megahertz band. If transmitting antennas of directional gain greater than 6 dBi are used, both the maximum conducted output power and the maximum power spectral density shall be reduced by the amount in dB that the directional gain of the antenna exceeds 6 dBi.
2. For the 5.25-5.35 GHz and 5.47-5.725 GHz bands, the maximum power spectral density shall not exceed 11 dBm in any 1 megahertz band. If transmitting antennas of directional gain greater than 6 dBi are used, both the maximum conducted output power and the maximum power spectral density shall be reduced by the amount in dB that the directional gain of the antenna exceeds 6 dBi.
3. For the band 5.725-5.850 GHz, the peak power spectral density shall not exceed 30 dBm in any 500KHz band. If transmitting antenna directional gain is greater than 6 dBi, both the maximum conducted output power and the peak power spectral density shall be reduced by the amount in dB that the directional gain of the antenna exceeds 6 dBi.

IC:

1. For the 5.15-5.25 GHz, The e.i.r.p. spectral density shall not exceed 10 dBm in any 1.0 MHz band.
2. For the 5.25-5.35 GHz and 5.47-5.725 GHz bands, The power spectral density shall not exceed 11 dBm in any 1.0 MHz band.
3. The output power spectral density shall not exceed 30 dBm in any 500 kHz band. If transmitting antennas of directional gain greater than 6 dBi are used, both the maximum conducted output power and the output power spectral density shall be reduced by the amount in dB that the directional gain of the antenna exceeds 6 dBi. However, fixed point-to-point devices operating in this band may employ transmitting antennas with directional gain greater than 6 dBi without any corresponding reduction in transmitter conducted power. Fixed point-to-point operations exclude the use of point-to-multipoint systems, omnidirectional applications and multiple collocated transmitters transmitting the same information.



5.2 TEST PROCEDURE

1. The setting follows Method SA-1 of FCC KDB D02 General UNII Test Procedures New Rules v01r03.

For devices operating in the band, the rules specify a measurement bandwidth of 500 kHz. Many spectrum analyzers do not have 500 kHz RBW, thus a narrower RBW may need to be used. The rules permit the use of a RBWs less than 1 MHz, or 500 kHz, “provided that the measured power is integrated over the full reference bandwidth” to show the total power over the specified measurement bandwidth (*i.e.*, 1 MHz, or 500 kHz). If measurements are performed using a reduced resolution bandwidth (< 1 MHz, or < 500 kHz) and integrated over 1 MHz, or 500 KHz bandwidth, the following adjustments to the procedures apply:

- a) Set $RBW \geq 1/T$, where T is defined in section II.B.I.a).
- b) Set $VBW \geq 3 RBW$.
- c) If measurement bandwidth of Maximum PSD is specified in 500 kHz, add $10 \log (500\text{kHz}/RBW)$ to the measured result, whereas $RBW (< 500 \text{ kHz})$ is the reduced resolution bandwidth of the spectrum analyzer set during measurement.
- d) If measurement bandwidth of Maximum PSD is specified in 1 MHz, add $10 \log (1\text{MHz}/RBW)$ to the measured result, whereas $RBW (< 1 \text{ MHz})$ is the reduced resolution bandwidth of spectrum analyzer set during measurement.
- e) Care must be taken to ensure that the measurements are performed during a period of continuous transmission or are corrected upward for duty cycle.

Note: As a practical matter, it is recommended to use reduced RBW of 100 kHz for the sections 5.c) and 5.d) above, since $RBW=100 \text{ KHZ}$ is available on nearly all spectrum analyzers.



5.3 DEVIATION FROM STANDARD

No deviation.

5.4 TEST SETUP



5.5 EUT OPERATION CONDITIONS

The EUT tested system was configured as the statements of 2.1 Unless otherwise a special operating condition is specified in the follows during the testing.

5.6 TEST RESULTS

5150-5250MHz					
Frequency	Power Density(dBm)	Duty cycle factor (dB)	Power Density(dBm)	Limit	Result
802.11a					
5180	-5.445	0.000	-5.445	11	PASS
5200	-4.968	0.000	-4.968	11	PASS
5240	-4.058	0.000	-4.058	11	PASS
802.11n20					
5180	-5.543	0.000	-5.543	11	PASS
5200	-5.303	0.000	-5.303	11	PASS
5240	-4.168	0.000	-4.168	11	PASS
802.11n40					
5190	-8.507	0.000	-8.507	11	PASS
5230	-7.461	0.000	-7.461	11	PASS
802.11ac20					
5180	-5.471	0.000	-5.471	11	PASS
5200	-5.337	0.000	-5.337	11	PASS
5240	-4.530	0.000	-4.530	11	PASS
802.11ac40					
5190	-8.691	0.000	-8.691	11	PASS
5230	-7.370	0.000	-7.370	11	PASS
802.11ac80					
5210	-9.575	0.000	-9.575	11	PASS



5250-5350MHz					
Frequency	Power Density(dBm)	Duty cycle factor (dB)	Power Density(dBm)	Limit	Result
802.11a					
5260	-4.157	0.000	-4.157	11	PASS
5300	-3.958	0.000	-3.958	11	PASS
5320	-3.730	0.000	-3.730	11	PASS
802.11n20					
5260	-5.167	0.000	-5.167	11	PASS
5300	-5.113	0.000	-5.113	11	PASS
5320	-3.748	0.000	-3.748	11	PASS
802.11n40					
5270	-7.776	0.000	-7.776	11	PASS
5310	-7.967	0.000	-7.967	11	PASS
802.11ac20					
5260	-4.967	0.000	-4.967	11	PASS
5300	-4.895	0.000	-4.895	11	PASS
5320	-4.746	0.000	-4.746	11	PASS
802.11ac40					
5270	-8.203	0.000	-8.203	11	PASS
5310	-7.997	0.000	-7.997	11	PASS
802.11ac80					
5290	-9.224	0.000	-9.224	11	PASS

5470-5725MHz					
Frequency	Power Density(dBm)	Duty cycle factor (dB)	Power Density(dBm)	Limit	Result
802.11a					
5500	-4.279	0.000	-4.279	11	PASS
5580	-5.404	0.000	-5.404	11	PASS
5700	-5.680	0.000	-5.680	11	PASS
802.11n20					
5500	-4.703	0.000	-4.703	11	PASS
5580	-5.856	0.000	-5.856	11	PASS
5700	-6.120	0.000	-6.120	11	PASS
802.11n40					
5510	-8.008	0.000	-8.008	11	PASS
5550	-8.813	0.000	-8.813	11	PASS
5670	-9.242	0.000	-9.242	11	PASS
802.11ac20					
5500	-4.854	0.000	-4.854	11	PASS
5580	-6.253	0.000	-6.253	11	PASS
5700	-6.689	0.000	-6.689	11	PASS
802.11ac40					
5510	-7.975	0.000	-7.975	11	PASS
5550	-8.995	0.000	-8.995	11	PASS
5670	-9.170	0.000	-9.170	11	PASS
802.11ac80					
5530	-9.782	0.000	-9.782	11	PASS
5610	-10.925	0.000	-10.925	11	PASS



5725-5850MHz					
Frequency	Power Density(dBm)	Duty cycle factor (dB)	Power Density(dBm)	Limit	Result
802.11a					
5745	-5.355	0.000	-5.355	30	PASS
5785	-4.871	0.000	-4.871	30	PASS
5825	-4.917	0.000	-4.917	30	PASS
802.11n20					
5745	-6.433	0.000	-6.433	30	PASS
5785	-5.688	0.000	-5.688	30	PASS
5825	-5.998	0.000	-5.998	30	PASS
802.11n40					
5755	-9.233	0.000	-9.233	30	PASS
5795	-8.932	0.000	-8.932	30	PASS
802.11ac20					
5745	-6.790	0.000	-6.790	30	PASS
5785	-6.090	0.000	-6.090	30	PASS
5825	-5.745	0.000	-5.745	30	PASS
802.11ac40					
5755	-9.028	0.000	-9.028	30	PASS
5795	-9.220	0.000	-9.220	30	PASS
802.11ac80					
5775	-11.202	0.000	-11.202	30	PASS



EIRP PSD

5150-5250MHz			
Frequency	Power Density Total(dBm)	Limit	Result
802.11a			
5180	-4.315	10	PASS
5200	-3.838	10	PASS
5240	-2.928	10	PASS
802.11n20			
5180	-4.413	10	PASS
5200	-4.173	10	PASS
5240	-3.038	10	PASS
802.11n40			
5190	-7.377	10	PASS
5230	-6.331	10	PASS
802.11ac20			
5180	-4.341	10	PASS
5200	-4.207	10	PASS
5240	-3.400	10	PASS
802.11ac40			
5190	-7.561	10	PASS
5230	-6.240	10	PASS
802.11ac80			
5210	-8.445	10	PASS

Data see Attachment B

6. BANDWIDTH MEASUREMENT

6.1 EMISSION BANDWIDTH (EBW) 26 BANDWID PROCEDURES / LIMIT

The following procedure shall be used for measuring 26 bandwidth.

6.1.1 TEST PROCEDURE

1. The testing follows FCC KDB 789033 D02 General UNII Test Procedures New Rules v02r01
2. Set RBW = approximately 1% of the emission bandwidth.
3. Set the VBW \geq RBW.
4. Detector = Peak.
5. Trace mode = max hold.
6. Measure the maximum width of the emission that is 26 dB down from the peak of the emission. Compare this with the RBW setting of the analyzer. Readjust RBW and repeat measurement as needed until the RBW/EBW ratio is approximately 1%.

6.1.2 DEVIATION FROM STANDARD

No deviation.

6.1.3 TEST SETUP



6.1.4 EUT OPERATION CONDITIONS

The EUT tested system was configured as the statements of 2.4 Unless otherwise a special operating condition is specified in the follows during the testing.

**6.1.5 TEST RESULTS**

Frequency (MHz)	26dB Bandwidth (MHz)	Pass/Fail
802.11a		
5180	20.07	Pass
5200	19.97	Pass
5240	19.99	Pass
802.11n(HT20)		
5180	20.85	Pass
5200	21.02	Pass
5240	20.87	Pass
802.11n(HT40)		
5190	41.38	Pass
5230	40.89	Pass
802.11ac(VHT20)		
5180	20.92	Pass
5200	20.92	Pass
5240	20.97	Pass
802.11ac(VHT40)		
5190	41.58	Pass
5230	41.19	Pass
802.11ac(VHT80)		
5210	81.44	Pass

Frequency (MHz)	26dB Bandwidth (MHz)	Pass/Fail
802.11a		
5260	20.16	Pass
5300	20.04	Pass
5320	20.00	Pass
802.11n(HT20)		
5260	20.85	Pass
5300	20.73	Pass
5320	20.93	Pass
802.11n(HT40)		
5270	41.47	Pass
5310	41.30	Pass
802.11ac(VHT20)		
5260	20.88	Pass
5300	20.88	Pass
5320	20.99	Pass
802.11ac(VHT40)		
5270	41.49	Pass
5310	41.38	Pass
802.11ac(VHT80)		
5290	81.16	Pass



Frequency (MHz)	26dB Bandwidth (MHz)	Pass/Fail
802.11a		
5500	19.99	Pass
5580	20.02	Pass
5700	20.07	Pass
802.11n(HT20)		
5500	20.96	Pass
5580	20.84	Pass
5700	20.91	Pass
802.11n(HT40)		
5510	41.38	Pass
5550	41.40	Pass
5670	41.33	Pass
802.11ac(VHT20)		
5500	20.96	Pass
5580	20.82	Pass
5700	20.93	Pass
802.11ac(VHT40)		
5510	41.70	Pass
5550	41.60	Pass
5670	41.23	Pass
802.11ac(VHT80)		
5530	80.94	Pass
5610	81.48	Pass

Frequency (MHz)	26dB Bandwidth (MHz)	Pass/Fail
802.11a		
5745	20.16	Pass
5785	20.09	Pass
5825	20.13	Pass
802.11n(HT20)		
5745	20.71	Pass
5785	20.91	Pass
5825	21.01	Pass
802.11n(HT40)		
5755	41.06	Pass
5795	41.35	Pass
802.11ac(VHT20)		
5745	20.78	Pass
5785	20.74	Pass
5825	20.70	Pass
802.11ac(VHT40)		
5755	41.00	Pass
5795	41.57	Pass
802.11ac(VHT80)		
5775	80.70	Pass

Note:

1. Antenna B Power > Antenna A Power, Both antenna A and B have been test, Only show the worst data of Antenna B.
2. Data See Attachment C.

6.2 OCCUPIED BANDWIDTH (99%) TEST APPLIED PROCEDURES / LIMIT

The following procedure shall be used for measuring (99 %) power bandwidth.

6.2.1 TEST PROCEDURE

1. The testing follows FCC KDB 789033 D02 General UNII Test Procedures v02r01.

The following procedure shall be used for measuring (99 %) power bandwidth:

1. Set center frequency to the nominal EUT channel center frequency.
2. Set span = 1.5 times to 5.0 times the OBW.
3. Set RBW = 1 % to 5 % of the OBW
4. Set VBW $\geq 3 \cdot$ RBW
5. Video averaging is not permitted. Where practical, a sample detection and single sweep mode shall be used. Otherwise, peak detection and max hold mode (until the trace stabilizes) shall be used.
6. Use the 99 % power bandwidth function of the instrument (if available).
7. If the instrument does not have a 99 % power bandwidth function, the trace data points are recovered and directly summed in power units. The recovered amplitude data points, beginning at the lowest frequency, are placed in a running sum until 0.5 % of the total is reached; that frequency is recorded as the lower frequency. The process is repeated until 99.5 % of the total is reached; that frequency is recorded as the upper frequency. The 99% occupied bandwidth is the difference between these two frequencies.

6.2.2 DEVIATION FROM STANDARD

No deviation.

6.2.3 TEST SETUP

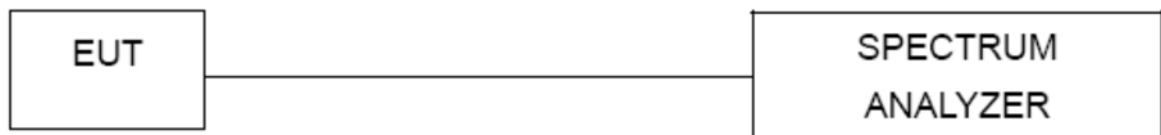

6.2.4 EUT OPERATION CONDITIONS

The EUT tested system was configured as the statements of 2.4 Unless otherwise a special operating condition is specified in the follows during the testing.



6.2.5 TEST RESULTS

Frequency (MHz)	99% Bandwidth (MHz)	Pass/Fail
802.11a		
5180	16.499	Pass
5200	16.497	Pass
5240	16.485	Pass
802.11n(HT20)		
5180	17.620	Pass
5200	17.607	Pass
5240	17.618	Pass
802.11n(HT40)		
5190	36.044	Pass
5230	36.025	Pass
802.11ac(VHT20)		
5180	17.624	Pass
5200	17.629	Pass
5240	17.616	Pass
802.11ac(VHT40)		
5190	36.053	Pass
5230	36.020	Pass
802.11ac(VHT80)		
5210	75.405	Pass

Frequency (MHz)	99% Bandwidth (MHz)	Pass/Fail
802.11a		
5260	16.487	Pass
5300	16.488	Pass
5320	16.494	Pass
802.11n(HT20)		
5260	17.613	Pass
5300	17.613	Pass
5320	17.614	Pass
802.11n(HT40)		
5270	36.027	Pass
5310	36.033	Pass
802.11ac(VHT20)		
5260	17.626	Pass
5300	17.626	Pass
5320	17.626	Pass
802.11ac(VHT40)		
5270	36.028	Pass
5310	36.022	Pass
802.11ac(VHT80)		
5290	75.412	Pass



Frequency (MHz)	99% Bandwidth (MHz)	Pass/Fail
802.11a		
5500	16.492	Pass
5580	16.496	Pass
5700	16.498	Pass
802.11n(HT20)		
5500	17.609	Pass
5580	17.612	Pass
5700	17.623	Pass
802.11n(HT40)		
5510	36.011	Pass
5550	36.065	Pass
5670	36.019	Pass
802.11ac(VHT20)		
5500	17.617	Pass
5580	17.613	Pass
5700	17.635	Pass
802.11ac(VHT40)		
5510	36.016	Pass
5550	36.078	Pass
5670	36.025	Pass
802.11ac(VHT80)		
5530	75.381	Pass
5610	75.386	Pass

Frequency (MHz)	99% Bandwidth (MHz)	Pass/Fail
802.11a		
5745	16.494	Pass
5785	16.497	Pass
5825	16.496	Pass
802.11n(HT20)		
5745	17.606	Pass
5785	17.611	Pass
5825	17.614	Pass
802.11n(HT40)		
5755	36.018	Pass
5795	36.042	Pass
802.11ac(VHT20)		
5745	17.610	Pass
5785	17.625	Pass
5825	17.619	Pass
802.11ac(VHT40)		
5755	36.022	Pass
5795	36.019	Pass
802.11ac(VHT80)		
5775	75.193	Pass

Note:

1. Antenna B Power > Antenna A Power, Both antenna A and B have been test, Only show the worst data of Antenna B.
2. Data See Attachment C.

6.3 MINIMUM EMISSION BANDWIDTH(6 DB) PROCEDURES / LIMIT

The minimum 6 dB emission bandwidth of at least 500 KHz for the band 5.725-5.85 GHz. The following procedure shall be used for measuring this bandwidth:

6.3.1 TEST PROCEDURE

1. The testing follows FCC KDB 789033 D02 General UNII Test Procedures v02r01.
 - a) Set RBW = 100 kHz.
 - b) Set the video bandwidth (VBW) $\geq 3 \times$ RBW.
 - c) Detector = Peak.
 - d) Trace mode = max hold.
 - e) Sweep = auto couple.
 - f) Allow the trace to stabilize.
 - g) Measure the maximum width of the emission that is constrained by the frequencies associated with the two outermost amplitude points (upper and lower frequencies) that are attenuated by 6 dB relative to the maximum level measured in the fundamental emission.

6.3.2 DEVIATION FROM STANDARD

No deviation.

6.3.3 TEST SETUP

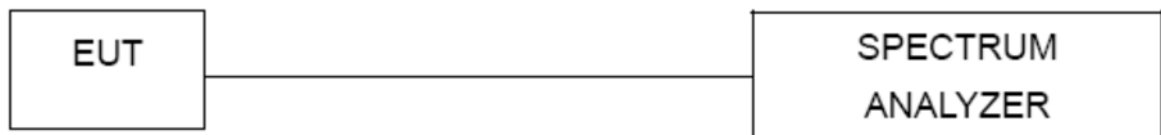

6.3.4 EUT OPERATION CONDITIONS

The EUT tested system was configured as the statements of 2.4 Unless otherwise a special operating condition is specified in the follows during the testing.

**6.3.5 TEST RESULTS**

Frequency (MHz)	6dB Bandwidth (MHz)	Pass/Fail
802.11a		
5745	16.50	Pass
5785	16.52	Pass
5825	16.51	Pass
802.11n(HT20)		
5745	17.65	Pass
5785	17.63	Pass
5825	17.65	Pass
802.11n(HT40)		
5755	36.41	Pass
5795	36.43	Pass
802.11ac(VHT20)		
5745	17.65	Pass
5785	17.63	Pass
5825	17.65	Pass
802.11ac(VHT40)		
5755	36.38	Pass
5795	36.42	Pass
802.11ac(VHT80)		
5775	75.47	Pass

Note:

1. Antenna B Power > Antenna A Power, Both antenna A and B have been test, Only show the worst data of Antenna B.
2. Data See Attachment D.



7. MAXIMUM CONDUCTED OUTPUT POWER

7.1 LIMIT

FCC:

For mobile and portable client devices in the 5.15-5.25 GHz band, the maximum conducted output power over the frequency band of operation shall not exceed 250 mW provided the maximum antenna gain does not exceed 6 dBi. If transmitting antennas of directional gain greater than 6 dBi are used, both the maximum conducted output power and the maximum power spectral density shall be reduced by the amount in dB that the directional gain of the antenna exceeds 6 dBi.

For the 5.25-5.35 GHz and 5.47-5.725 GHz bands, the maximum conducted output power over the frequency bands of operation shall not exceed the lesser of 250 mW or 11 dBm + 10 log B, where B is the 26 dB emission bandwidth in megahertz, if transmitting antennas of directional gain greater than 6 dBi are used.

For the band 5.725-5.85 GHz, the maximum conducted output power over the frequency band of operation shall not exceed 1 W. If transmitting antennas of directional gain greater than 6 dBi are used.

FCC Part15 (15.407) , Subpart E				
Section	Test Item	Limit	Frequency Range (MHz)	Result
15.407(a) (1) (iv)	Peak Output Power	0.25 watt	5150-5250	PASS
		The lesser of 250 mW or 11 dBm + 10 log (26 dB emission bandwidth)	5250-5350 5470-5725	
15.407(a) (3)		1 watt	5725-5825	

IC:

For devices in the 5.15-5.25 GHz band, the maximum e.i.r.p. shall not exceed 200 mW or $10 + 10 \log_{10}B$, dBm, whichever power is less. B is the 99% emission bandwidth in megahertz.

For the 5.25-5.35 GHz and 5.47-5.725 GHz bands, The maximum conducted output power shall not exceed 250 mW or $11 + 10 \log_{10}B$, dBm, whichever is less. The power spectral density shall not exceed 11 dBm in any 1.0 MHz band.

The maximum conducted output power shall not exceed 1 W. If transmitting antennas of directional gain greater than 6 dBi are used, both the maximum conducted output power and the output power spectral density shall be reduced by the amount in dB that the directional gain of the antenna exceeds 6 dBi. However, fixed point-to-point devices operating in this band may employ transmitting antennas with directional gain greater than 6 dBi without any corresponding reduction in transmitter conducted power. Fixed point-to-point operations exclude the use of point-to-multipoint systems, omnidirectional applications and multiple collocated transmitters transmitting the same information.

RSS-247 Issue 2, February 2017				
Section	Test Item	Limit	Frequency Range (MHz)	Result
6.2.1.1	Peak Output Power	200 mW or $10 + 10 \log_{10}B$, dBm, whichever power is less. B is the 99% emission bandwidth in megahertz	5150-5250	PASS
6.2.2.1 6.2.3.1		The lesser of 250 mW or $11 \text{ dBm} + 10 \log(26 \text{ dB emission bandwidth})$	5250-5350 5470-5725	
6.2.4.1		1 watt	5725-5825	

7.2 TEST PROCEDURE

The EUT was directly connected to the Power Sensor&PC

7.3 DEVIATION FROM STANDARD

No deviation.

7.4 TEST SETUP

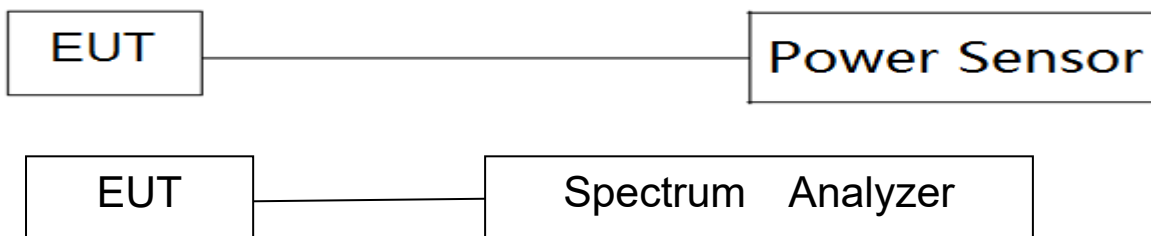

7.5 EUT OPERATION CONDITIONS

The EUT tested system was configured as the statements of 5 Unless otherwise a special operating condition is specified in the follows during the testing.

**7.6 TEST RESULTS****Note:**

1. For mobile and portable client devices in the 5.15-5.25 GHz band, the maximum conducted output power over the frequency band of operation shall not exceed the lesser of 0.25 W.
2. For mobile and portable client devices in the 5.25-5.35 GHz band, the maximum conducted output power over the frequency band of operation shall not exceed the lesser of 0.25 W.
3. For mobile and portable client devices in the 5.47-5.725 GHz band, the maximum conducted output power over the frequency band of operation shall not exceed the lesser of 0.25 W.
4. For the band 5.745-5.850 GHz, the maximum conducted output power over the frequency band of operation shall not exceed the lesser of 1 W.

Band I (5.15-5.25GHz)							
Test Channel	Frequency (MHz)	PK Power (dBm)	AV Power (dBm)	Duty cycle factor	PK Power (dBm)	AV Power (dBm)	LIMIT (dBm)
802.11a							
36	5180	16.99	7.42	0.00	16.99	7.42	23.98
40	5200	17.14	7.66	0.00	17.14	7.66	23.98
48	5240	17.78	8.26	0.00	17.78	8.26	23.98
802.11n(HT20)							
36	5180	16.01	7.11	0.00	16.01	7.11	23.98
40	5200	16.14	7.43	0.00	16.14	7.43	23.98
48	5240	16.59	7.91	0.00	16.59	7.91	23.98
802.11n(HT40)							
38	5190	15.72	7.08	0.00	15.72	7.08	23.98
46	5230	16.51	7.87	0.00	16.51	7.87	23.98
802.11ac(VHT20)							
36	5180	16.23	7.31	0.00	16.23	7.31	23.98
40	5200	16.62	7.66	0.00	16.62	7.66	23.98
48	5240	16.87	7.93	0.00	16.87	7.93	23.98
802.11ac(VHT40)							
38	5190	15.79	7.06	0.00	15.79	7.06	23.98
46	5230	16.49	7.74	0.00	16.49	7.74	23.98
802.11ac(VHT80)							
42	5210	15.26	7.56	0.00	15.26	7.56	23.98



Band II(5.25-5.35GHz)							
Test Channel	Frequency (MHz)	PK Power (dBm)	AV Power (dBm)	Duty cycle factor	PK Power (dBm)	AV Power (dBm)	LIMIT (dBm)
802.11a							
52	5260	18.24	8.55	0.00	18.24	8.55	23.98
60	5300	18.19	8.66	0.00	18.19	8.66	23.98
64	5320	18.11	8.54	0.00	18.11	8.54	23.98
802.11n(HT20)							
52	5260	16.89	8.16	0.00	16.89	8.16	23.98
60	5300	17.05	8.38	0.00	17.05	8.38	23.98
64	5320	16.95	8.24	0.00	16.95	8.24	23.98
802.11n(HT40)							
54	5270	17.11	8.34	0.00	17.11	8.34	23.98
62	5310	16.93	8.29	0.00	16.93	8.29	23.98
802.11ac(VHT20)							
52	5260	17.57	8.55	0.00	17.57	8.55	23.98
60	5300	17.71	8.61	0.00	17.71	8.61	23.98
64	5320	17.59	8.65	0.00	17.59	8.65	23.98
802.11ac(VHT40)							
54	5270	16.8	8.06	0.00	16.80	8.06	23.98
62	5310	17.04	8.25	0.00	17.04	8.25	23.98
802.11ac(VHT80)							
58	5290	15.51	8.21	0.00	15.51	8.21	23.98

Band III(5.47-5.725GHz)							
Test Channel	Frequency (MHz)	PK Power (dBm)	AV Power (dBm)	Duty cycle factor	PK Power (dBm)	AV Power (dBm)	LIMIT (dBm)
802.11a							
100	5500	17.65	8.29	0.00	17.65	8.29	23.98
116	5580	17.12	7.77	0.00	17.12	7.77	23.98
140	5700	17.03	7.53	0.00	17.03	7.53	23.98
802.11n(HT20)							
100	5500	16.68	8.04	0.00	16.68	8.04	23.98
116	5580	16.21	7.65	0.00	16.21	7.65	23.98
140	5700	16.59	7.91	0.00	16.59	7.91	23.98
802.11n(HT40)							
102	5510	16.53	8.00	0.00	16.53	8.00	23.98
110	5550	16.47	7.66	0.00	16.47	7.66	23.98
134	5670	16.31	7.46	0.00	16.31	7.46	23.98
802.11ac(VHT20)							
100	5500	17	8.11	0.00	17.00	8.11	23.98
116	5580	16.63	7.65	0.00	16.63	7.65	23.98
140	5700	16.56	7.47	0.00	16.56	7.47	23.98
802.11ac(VHT40)							
102	5510	16.48	7.75	0.00	16.48	7.75	23.98
110	5550	16.47	7.67	0.00	16.47	7.67	23.98
134	5670	16.24	7.42	0.00	16.24	7.42	23.98
802.11ac(VHT80)							
106	5530	16.33	9.09	0.00	16.33	9.09	23.98
122	5610	15.4	7.87	0.00	15.40	7.87	23.98



Band IV (5.725-5.85GHz)							
Test Channel	Frequency (MHz)	PK Power (dBm)	AV Power (dBm)	Duty cycle factor	PK Power (dBm)	AV Power (dBm)	LIMIT (dBm)
802.11a							
149	5745	17.55	7.93	0.00	17.55	7.93	30
157	5785	17.98	8.37	0.00	17.98	8.37	30
165	5825	18.24	8.58	0.00	18.24	8.58	30
802.11n(HT20)							
149	5745	16.5	7.73	0.00	16.50	7.73	30
157	5785	16.8	8.05	0.00	16.80	8.05	30
165	5825	16.84	8.17	0.00	16.84	8.17	30
802.11n(HT40)							
151	5755	16.62	7.76	0.00	16.62	7.76	30
159	5795	16.95	8.10	0.00	16.95	8.10	30
802.11ac(VHT20)							
149	5745	17.04	7.94	0.00	17.04	7.94	30
157	5785	17.34	8.26	0.00	17.34	8.26	30
165	5825	17.7	8.66	0.00	17.70	8.66	30
802.11ac(VHT40)							
151	5755	16.78	7.82	0.00	16.78	7.82	30
159	5795	17.04	8.21	0.00	17.04	8.21	30
802.11ac(VHT80)							
155	5775	15.21	7.94	0.00	15.21	7.94	30

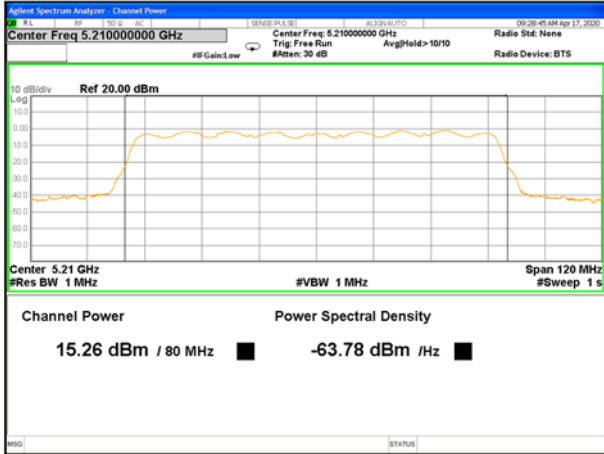

5210MHz_PK

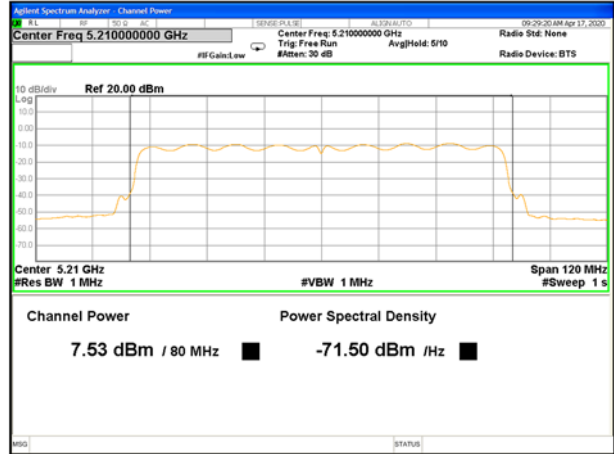

5210MHz_AV

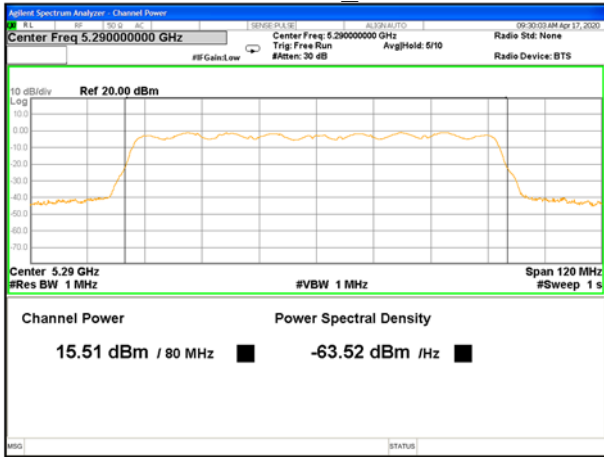

5290MHz_PK

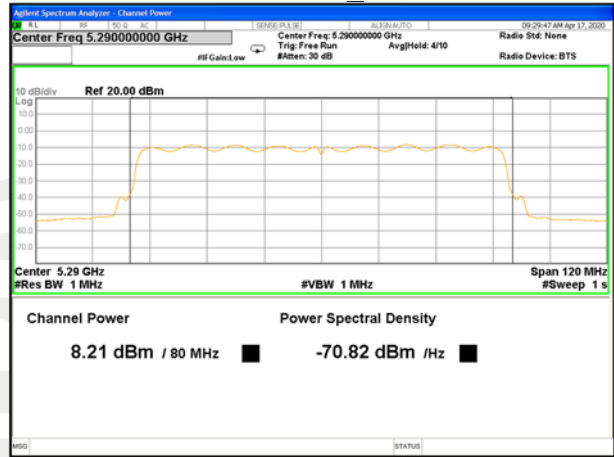

5290MHz_AV

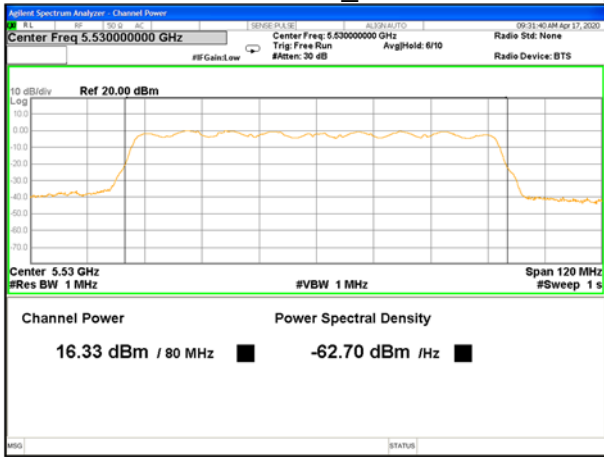

5530MHz_PK

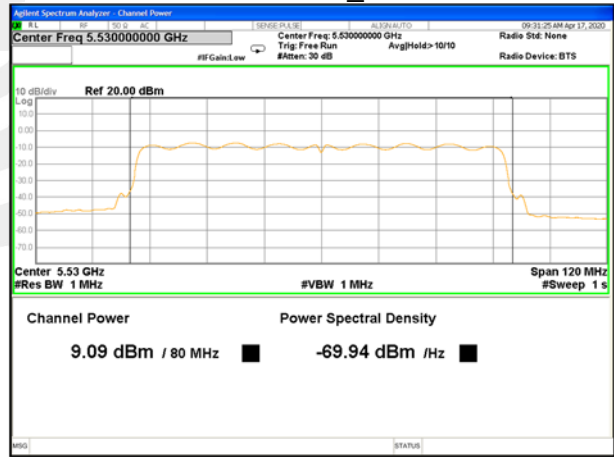

5530MHz_AV

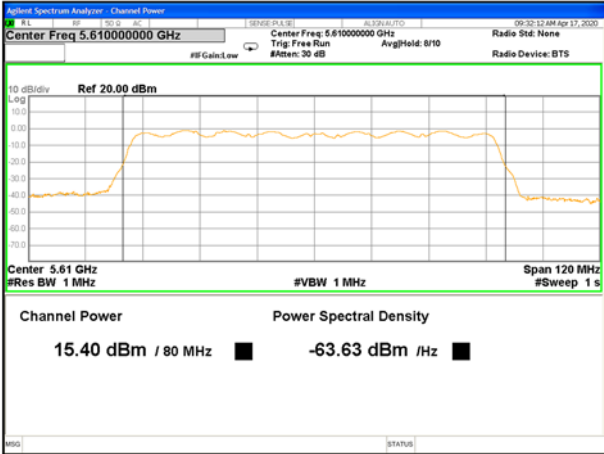

5610MHz_PK

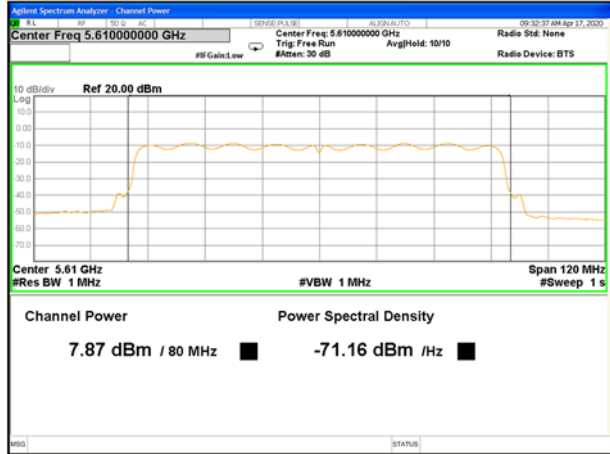

5610MHz_AV

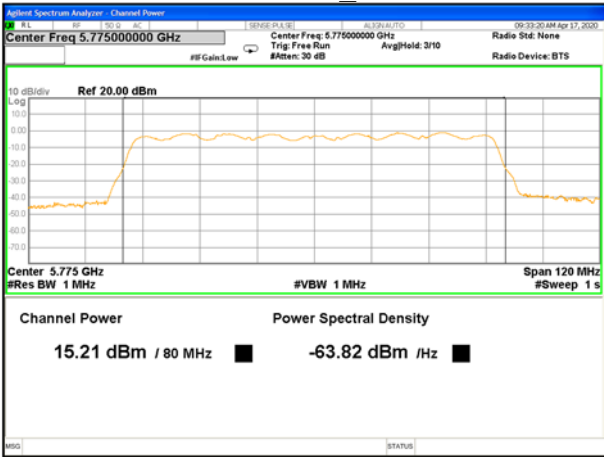

5775MHz_PK

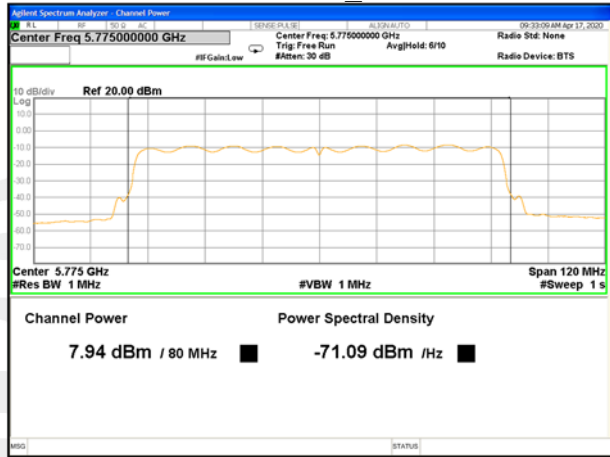

5775MHz_AV



EIRP Power

Band I (5.15-5.25GHz)-EIRP					
Test Channel	Frequency (MHz)	AV Power (dBm)	Antenna Gain(dBi)	EIRP Power(dBm)	LIMIT (dBm)
802.11a					
36	5180	7.42	1.13	8.55	23.01
40	5200	7.66	1.13	8.79	23.01
48	5240	8.26	1.13	9.39	23.01
802.11n(HT20)					
36	5180	7.11	1.13	8.24	23.01
40	5200	7.43	1.13	8.56	23.01
48	5240	7.91	1.13	9.04	23.01
802.11n(HT40)					
38	5190	7.08	1.13	8.21	23.01
46	5230	7.87	1.13	9.00	23.01
802.11ac(HT20)					
36	5180	7.31	1.13	8.44	23.01
40	5200	7.66	1.13	8.79	23.01
48	5240	7.93	1.13	9.06	23.01
802.11ac(HT40)					
38	5190	7.06	1.13	8.19	23.01
46	5230	7.74	1.13	8.87	23.01
802.11ac(HT80)					
42	5210	7.56	1.13	8.69	23.01



Duty Cycle

Band1				
Mode	Ton(ms)	Tp(ms)	Duty cycle(%)	Duty factor(dB)
a	1.000	1.000	100.00%	0.00
n20	1.000	1.000	100.00%	0.00
n40	1.000	1.000	100.00%	0.00
ac20	1.000	1.000	100.00%	0.00
ac40	1.000	1.000	100.00%	0.00
ac80	1.000	1.000	100.00%	0.00
Band2				
Mode	Ton(ms)	Tp(ms)	Duty cycle(%)	Duty factor(dB)
a	1.000	1.000	100.00%	0.00
n20	1.000	1.000	100.00%	0.00
n40	1.000	1.000	100.00%	0.00
ac20	1.000	1.000	100.00%	0.00
ac40	1.000	1.000	100.00%	0.00
ac80	1.000	1.000	100.00%	0.00
Band3				
Mode	Ton(ms)	Tp(ms)	Duty cycle(%)	Duty factor(dB)
a	1.000	1.000	100.00%	0.00
n20	1.000	1.000	100.00%	0.00
n40	1.000	1.000	100.00%	0.00
ac20	1.000	1.000	100.00%	0.00
ac40	1.000	1.000	100.00%	0.00
ac80	1.000	1.000	100.00%	0.00
Band4				
Mode	Ton(ms)	Tp(ms)	Duty cycle(%)	Duty factor(dB)
a	1.000	1.000	100.00%	0.00
n20	1.000	1.000	100.00%	0.00
n40	1.000	1.000	100.00%	0.00
ac20	1.000	1.000	100.00%	0.00
ac40	1.000	1.000	100.00%	0.00
ac80	1.000	1.000	100.00%	0.00



Band 1-a20



Band 1-n20

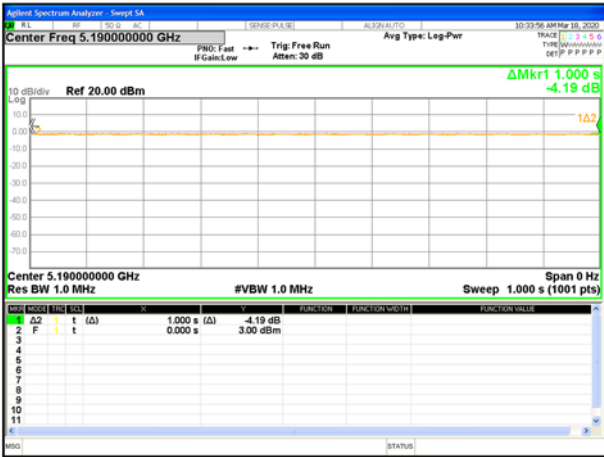

Band 1-n40

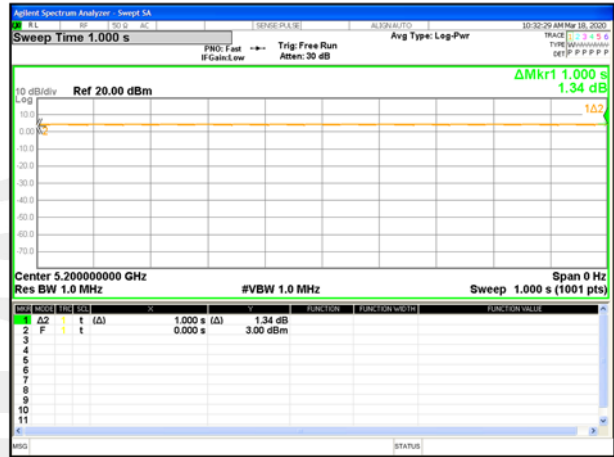

Band 1-ac20

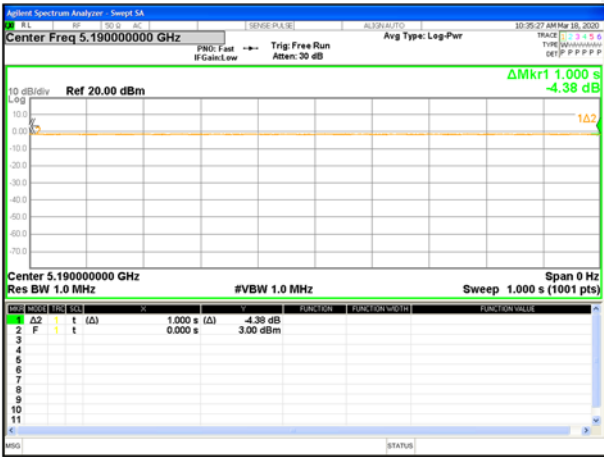

Band 1-ac40

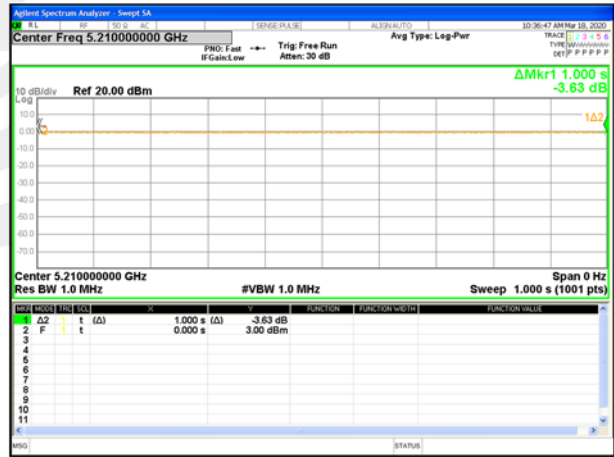

Band 1-ac80



Band 2-a20



Band 2-n20

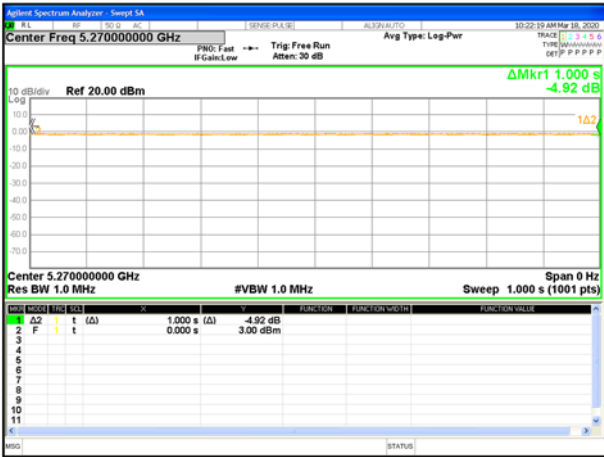

Band 2-a20

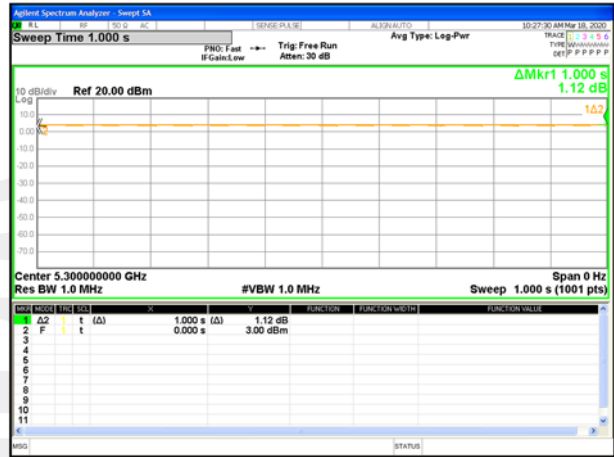

Band 2-n20

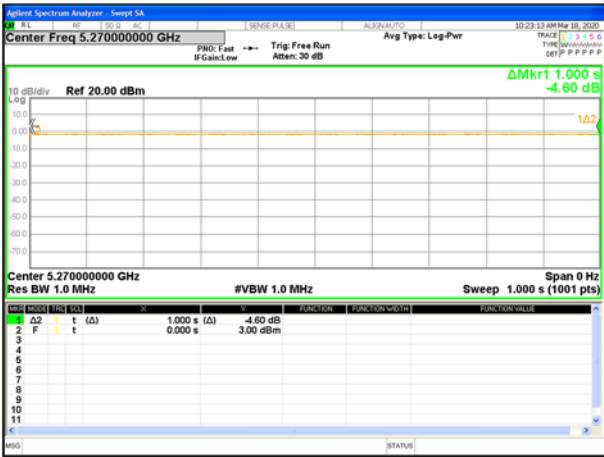

Band 2-a20

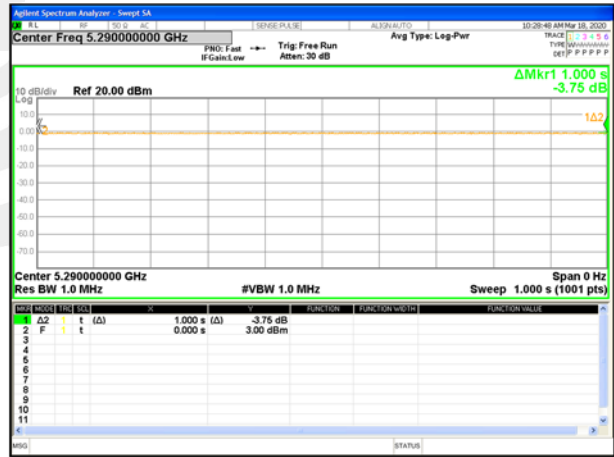

Band 2-ac20



Band 3-a20



Band 3-n20

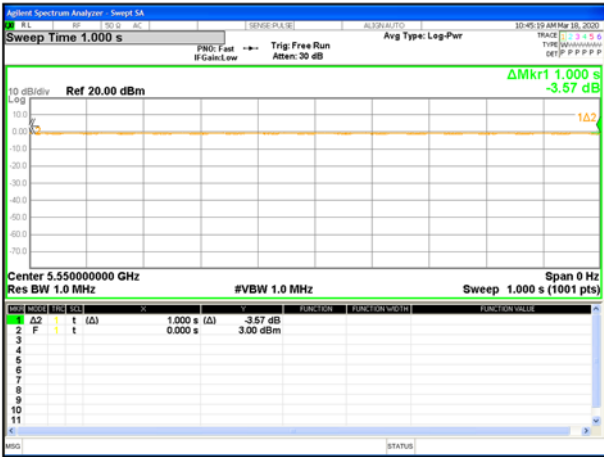

Band 3-n40

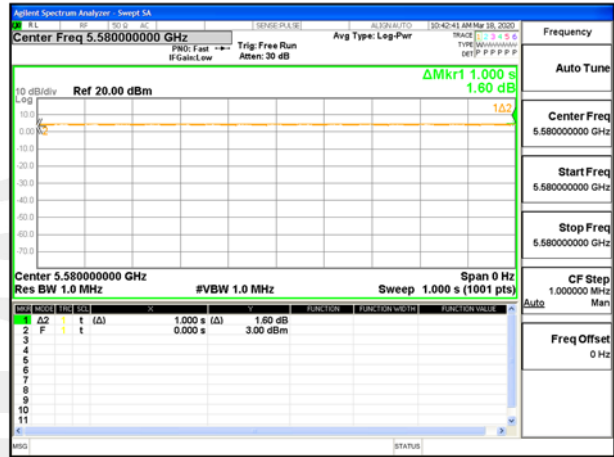

Band 3-ac20

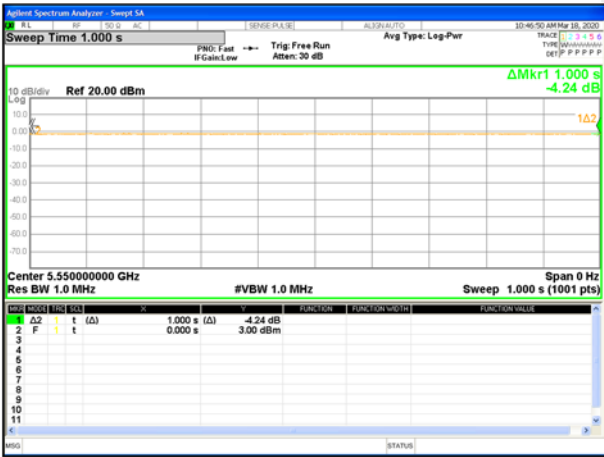

Band 3-ac40

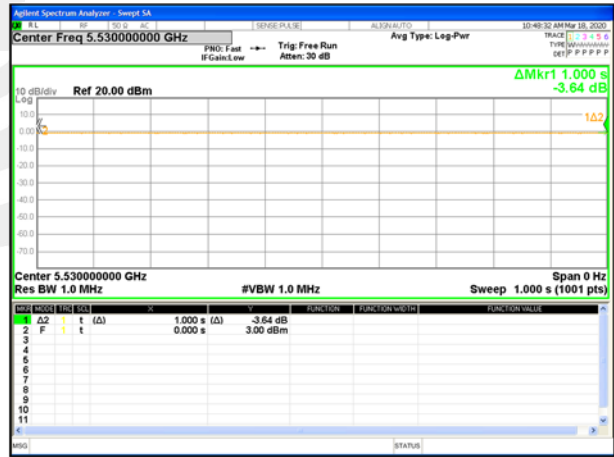

Band 3-ac80

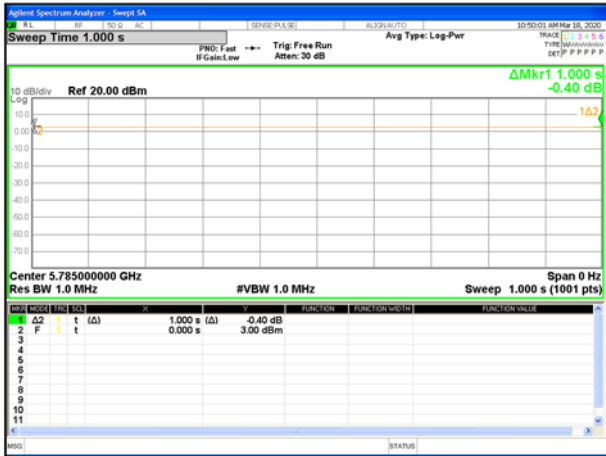

Band 4-a20



Band 4-n20

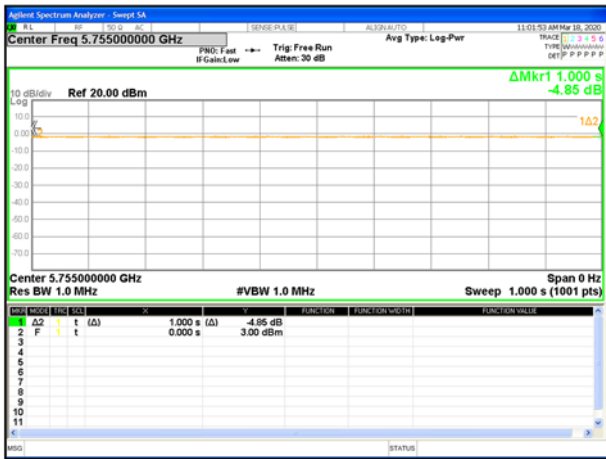

Band 4-n40



Band 4-ac20

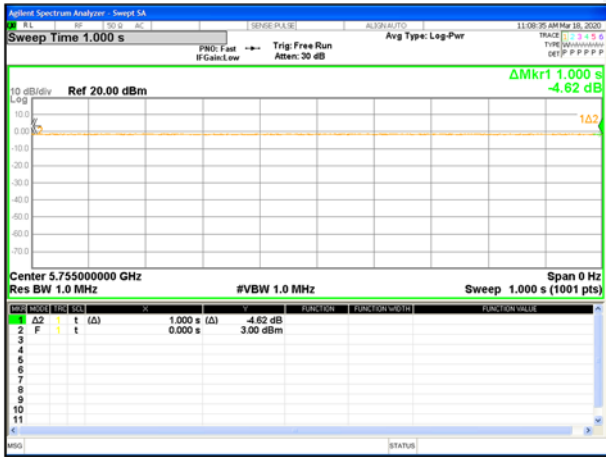

Band 4-ac40

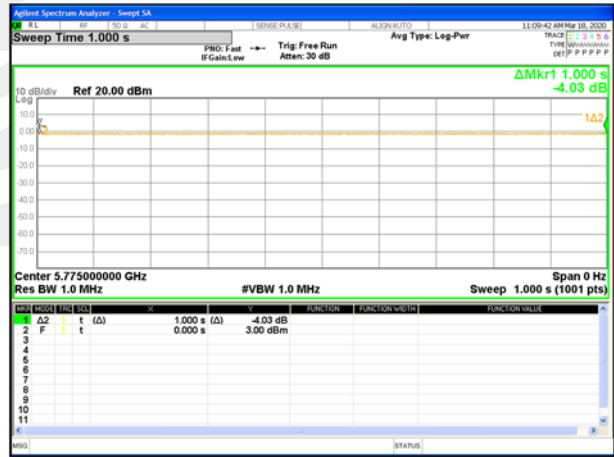

Band 4-ac80



8. AUTOMATICALLY DISCONTINUE TRANSMISSION

8.1 LIMIT OF AUTOMATICALLY DISCONTINUE TRANSMISSION

The device shall automatically discontinue transmission in case of either absence of information to transmit or operational failure. These provisions are not intended to preclude the transmission of control or signaling information or the use of repetitive codes used by certain digital technologies to complete frame or burst intervals. Applicants shall include in their application for equipment authorization to describe how this requirement is met.

8.2 TEST RESULT OF AUTOMATICALLY DISCONTINUE TRANSMISSION

During no any information transmission, the EUT can automatically discontinue transmission and become standby mode for power saving. The EUT can detect the controlling signal of ACK message transmitting from remote device and verify whether it shall resend or discontinue transmission

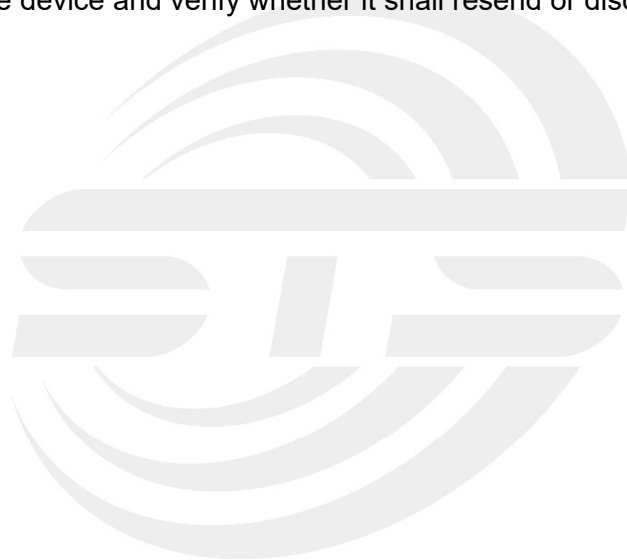



9. ANTENNA REQUIREMENT

9.1 STANDARD REQUIREMENT

15.203&RSS GEN requirement: For intentional device, according to 15.203&RSS GEN: an intentional radiator shall be designed to ensure that no antenna other than that furnished by the responsible party shall be used with the device.

9.2 EUT ANTENNA

1. The EUT antenna is PIFA Antenna, the antenna connection port is located inside the product casing that will not be easily opened. It comply with the standard requirement. You can refer to KDB353028 D01 Antennas Part 15 Transmitters v01 (II. A. 2. b).
2. The EUT has two antennas, the main antenna is TX function, and the auxiliary antenna is RX function.





10. FREQUENCY STABILITY

10.1 LIMITS OF FREQUENCY STABILITY MEASUREMENT

The frequency tolerance of the carrier signal shall be maintained within +/-0.02% of the operating frequency over a temperature variation of -30 degrees to 50 degrees C at normal supply voltage, and for a variation in primary supply voltage from 85% to 115% of the rated supply voltage at a temperature of 20 degrees.

10.2 TEST PROCEDURE

1. The EUT was placed inside the environmental test chamber and powered by nominal DC voltage.
2. Turn the EUT on and couple its output to spectrum analyzer.
3. Turn the EUT off and set the chamber to the highest temperature specified.
4. Allow sufficient time (approximately 30 min) for the temperature of the chamber to stabilize, turn the EUT on and measure the operating frequency after 2, 5, and 10 minutes.
5. Repeat step 2 and 3 with the temperature chamber set to the lowest temperature.
6. The test chamber was allowed to stabilize at +20 degree C for a minimum of 30 minutes. The supply voltage was then adjusted on the EUT from 85% to 115% and the frequency record.

10.3 TEST RESULT

Channel 40 (5200MHz)

Voltage vs. Frequency Stability

Voltage(V)	Measurement Frequency(MHz)
17.71	5200.0029
15.4	5200.0021
13.09	5200.0025
Max.Deviation(MHz)	0.0029
Max.Deviation(ppm)	0.56

Rated working voltage: DC 15.4V

Temperature vs. Frequency Stability

Temperature(°C)	Measurement Frequency(MHz)
-30	5200.0032
-20	5200.0026
-10	5200.0029
0	5200.0025
10	5200.0025
20	5200.0029
30	5200.0028
40	5200.0026
50	5200.0024
Max.Deviation(MHz)	0.0032
Max.Deviation(ppm)	0.62



Channel 60 (5300MHz)

Voltage vs. Frequency Stability

Voltage(V)	Measurement Frequency(MHz)
17.71	5300.0031
15.4	5300.0023
13.09	5300.0022
Max.Deviation(MHz)	0.0031
Max.Deviation(ppm)	0.58

Rated working voltage: DC 15.4V

Temperature vs. Frequency Stability

Temperature(°C)	Measurement Frequency(MHz)
-30	5300.0033
-20	5300.0030
-10	5300.0030
0	5300.0028
10	5300.0025
20	5300.0027
30	5300.0030
40	5300.0033
50	5300.0026
Max.Deviation(MHz)	0.0033
Max.Deviation(ppm)	0.62



Channel 116 (5580MHz)

Voltage vs. Frequency Stability

Voltage(V)	Measurement Frequency(MHz)
17.71	5580.0028
15.4	5580.0022
13.09	5580.0019
Max.Deviation(MHz)	0.0028
Max.Deviation(ppm)	0.50

Rated working voltage: DC 15.4V

Temperature vs. Frequency Stability

Temperature(°C)	Measurement Frequency(MHz)
-30	5580.0035
-20	5580.0030
-10	5580.0028
0	5580.0027
10	5580.0026
20	5580.0026
30	5580.0025
40	5580.0032
50	5580.0030
Max.Deviation(MHz)	0.0035
Max.Deviation(ppm)	0.63



Channel 157 (5785MHz)

Voltage vs. Frequency Stability

Voltage(V)	Measurement Frequency(MHz)
17.71	5785.0033
15.4	5785.0027
13.09	5785.0027
Max.Deviation(MHz)	0.0033
Max.Deviation(ppm)	0.57

Rated working voltage: DC 15.4V

Temperature vs. Frequency Stability

Temperature(°C)	Measurement Frequency(MHz)
-30	5785.0030
-20	5785.0029
-10	5785.0026
0	5785.0022
10	5785.0024
20	5785.0027
30	5785.0022
40	5785.0028
50	5785.0023
Max.Deviation(MHz)	0.0030
Max.Deviation(ppm)	0.52



APPENDIX - PHOTOS OF TEST SETUP

Note: See test photos in setup photo document for the actual connections between Product and support equipment.

※※※※END OF THE REPORT※※※※

