

FCC Test Report

Equipment : Ultra Rugged Tablet PC
Brand Name : Winmate
Model No. : M133XXXXXXXXX
(The "X" can be 0-9, A-Z, a-z, +, or blank for marketing purpose.)
FCC ID : PX9M133NGW
Standard : 47 CFR FCC Part 15.247
Operating Band : 2400 MHz – 2483.5 MHz
FCC Classification : DTS
**Applicant/
Manufacturer** : Winmate Communication INC.
9F, No. 111-6, Shing-De Rd., San-Chung Dist,
New Taipei 24158, Taiwan, R.O.C.

The product sample received on Aug. 17, 2015 and completely tested on Nov. 04, 2015. We, SPORTON, would like to declare that the tested sample has been evaluated in accordance with the procedures given in ANSI C63.10-2013 and shown compliance with the applicable technical standards.

The test results in this report apply exclusively to the tested model / sample. Without written approval of SPORTON INTERNATIONAL INC., the test report shall not be reproduced except in full.

Reviewed by:



Kevin Liang / Assistant Manager





Table of Contents

- 1 GENERAL DESCRIPTION5**
- 1.1 Information.....5
- 1.2 Accessories7
- 1.3 Testing Applied Standards7
- 1.4 Testing Location Information7
- 1.5 Measurement Uncertainty8
- 2 TEST CONFIGURATION OF EUT9**
- 2.1 The Worst Case Modulation Configuration9
- 2.2 The Worst Case Power Setting Parameter9
- 2.3 The Worst Case Measurement Configuration10
- 2.4 Test Setup Diagram 11
- 3 TRANSMITTER TEST RESULT13**
- 3.1 AC Power-line Conducted Emissions13
- 3.2 6dB Bandwidth16
- 3.3 RF Output Power.....18
- 3.4 Power Spectral Density20
- 3.5 Transmitter Bandedge Emissions22
- 3.6 Transmitter Unwanted Emissions.....25
- 4 TEST EQUIPMENT AND CALIBRATION DATA36**

APPENDIX A. TEST PHOTOS

APPENDIX B. PHOTOGRAPHS OF EUT



Summary of Test Result

Conformance Test Specifications					
Report Clause	Ref. Std. Clause	Description	Measured	Limit	Result
1.1.2	15.203	Antenna Requirement	Antenna connector mechanism complied	FCC 15.203	Complied
3.1	15.207	AC Power-line Conducted Emissions	[dBuV]: 0.1914470MHz 54.36 (Margin 9.61dB) - QP 38.82 (Margin 15.15dB) - AV	FCC 15.207	Complied
3.2	15.247(a)	6dB Bandwidth	LE: 651.20kHz	≥500kHz	Complied
3.3	15.247(b)	RF Output Power (Maximum Peak Conducted Output Power)	Power [dBm] LE: 6.10	Power [dBm] LE:30	Complied
3.4	15.247(e)	Power Spectral Density	PSD [dBm/100kHz] LE: -10.30	PSD [dBm/3kHz]: 8	Complied
3.5	15.247(d)	Transmitter Bandedge Emissions	Restricted Bands [dBuV/m at 3m]: 2484.64MHz 57.54 (Margin 16.46dB) - PK 44.76 (Margin 9.24dB) - AV	Non-Restricted Bands: > 20 dBc Restricted Bands: FCC 15.209	Complied
3.6	15.247(d)	Transmitter Unwanted Emissions	Restricted Bands [dBuV/m at 3m]: 144.46MHz 37.33 (Margin 6.17dB) - PK	Non-Restricted Bands: > 20 dBc Restricted Bands: FCC 15.209	Complied



1 General Description

1.1 Information

1.1.1 RF General Information

RF General Information				
Frequency Range (MHz)	Bluetooth Version	Ch. Frequency (MHz)	Channel Number	RF Output Power (dBm)
2400-2483.5	v4.0 LE	2402-2480	0-39 [40]	6.10

Note 1: Bluetooth LE (Low Energy) using GFSK modulation for DTS digital modulation.
Note 2: RF output power specifies that Maximum Peak Conducted Output Power.

1.1.2 Antenna Information

Antenna Category	
<input checked="" type="checkbox"/>	Integral antenna (antenna permanently attached)
<input type="checkbox"/>	Temporary RF connector provided
<input checked="" type="checkbox"/>	No temporary RF connector provided Transmit chains bypass antenna and soldered temporary RF connector provided for connected measurement. In case of conducted measurements the transmitter shall be connected to the measuring equipment via a suitable attenuator and correct for all losses in the RF path.

Antenna General Information		
Ant. Cat.	Ant. Type	Gain (dBi)
Integral	PIFA	2.00



1.1.3 Type of EUT

Identify EUT	
EUT Serial Number	N/A
Presentation of Equipment	<input type="checkbox"/> Production ; <input checked="" type="checkbox"/> Pre-Production ; <input type="checkbox"/> Prototype
Type of EUT	
<input checked="" type="checkbox"/>	Stand-alone
<input type="checkbox"/>	Combined (EUT where the radio part is fully integrated within another device) Combined Equipment – Brand Name / Model No.: ...
<input type="checkbox"/>	Plug-in radio (EUT intended for a variety of host systems) Host System – Brand Name / Model No.: ...
<input type="checkbox"/>	Other:

1.1.4 Test Signal Duty Cycle

Operated Mode for Worst Duty Cycle	
<input checked="" type="checkbox"/> Operated test mode for worst duty cycle	
Test Signal Duty Cycle (x)	Power Duty Factor [dB] – (10 log 1/x)
<input checked="" type="checkbox"/> 73.81% - test mode single channel – LE	1.32

1.1.5 EUT Operational Condition

Supply Voltage	<input checked="" type="checkbox"/> AC mains	<input checked="" type="checkbox"/> DC	
Type of DC Source	<input checked="" type="checkbox"/> Internal DC supply	<input checked="" type="checkbox"/> From system	<input checked="" type="checkbox"/> Li-ion Battery

1.2 Accessories

Accessories Information				
AC Adapter	Brand Name	EDAC	Model Name	EA10633B-190
	Power Rating	I/P: 100 - 240 Vac, 2000 mA, O/P: 19 Vdc, 3420 mA		
Li-ion Battery 1	Brand Name	Jhieh-Hong	Model Name	B5007
	Power Rating	7.4 Vdc, 10280 mAh		
Li-ion Battery 2	Brand Name	Jhieh-Hong	Model Name	B5036
	Power Rating	7.4 Vdc, 350 mAh		

Note: Regarding to more detail and other information, please refer to user manual. Reminder: Regarding to more detail and other information, please refer to user manual.

1.3 Testing Applied Standards

According to the specifications of the manufacturer, the EUT must comply with the requirements of the following standards:

- ◆ 47 CFR FCC Part 15
- ◆ ANSI C63.10-2013
- ◆ FCC KDB 558074 D01 v03r03

1.4 Testing Location Information

Testing Location				
<input checked="" type="checkbox"/>	HWA YA	ADD : No. 52, Hwa Ya 1st Rd., Hwa Ya Technology Park, Kwei-Shan District, Tao Yuan City, Taiwan, R.O.C.		
		TEL : 886-3-327-3456	FAX : 886-3-327-0973	
<input checked="" type="checkbox"/>	HWA YA	ADD No.13-1, Ln. 19, Wen 33rd St., Guishan Dist., Taoyuan City 333, Taiwan, R.O.C.		
		TEL : 886-3-318-0787	FAX : 886-3-318-0287	
Test Condition		Test Site No.	Test Engineer	Test Environment
AC Conduction		CO04-HY	Anthony	21°C / 61%
RF Conducted		TH06-HY	Jason	21°C / 62%
Radiated Emission		03CH09-HY	Terry	24.2°C / 61.8%

1.5 Measurement Uncertainty

ISO/IEC 17025 requires that an estimate of the measurement uncertainties associated with the emissions test results be included in the report. The measurement uncertainties given below are based on a 95% confidence level (based on a coverage factor (k=2))

Measurement Uncertainty		
Test Item		Uncertainty
AC power-line conducted emissions		±2.3 dB
Emission bandwidth, 6dB bandwidth		±0.6 %
RF output power, conducted		±0.1 dB
Power density, conducted		±0.6 dB
Unwanted emissions, conducted	9 – 150 kHz	±0.4 dB
	0.15 – 30 MHz	±0.4 dB
	30 – 1000 MHz	±0.6 dB
	1 – 18 GHz	±0.5 dB
	18 – 40 GHz	±0.5 dB
	40 – 200 GHz	N/A
All emissions, radiated	9 – 150 kHz	±2.5 dB
	0.15 – 30 MHz	±2.3 dB
	30 – 1000 MHz	±2.6 dB
	1 – 18 GHz	±3.6 dB
	18 – 40 GHz	±3.8 dB
	40 – 200 GHz	N/A
Temperature		±0.8 °C
Humidity		±5 %
DC and low frequency voltages		±0.9%
Time		±1.4 %
Duty Cycle		±0.6 %

2 Test Configuration of EUT

2.1 The Worst Case Modulation Configuration

Worst Modulation Used for Conformance Testing			
Bluetooth Version	Transmit Chains (N _{TX})	Data Rate	Modulation Mode
LE	1	1 Mbps	LE-1Mbps
Note 1: Bluetooth LE (Low Energy) using GFSK modulation for DTS digital modulation. Note 2: Modulation modes consist below configuration: DSSS LE-1Mbps: GFSK (1Mbps)			



2.2 The Worst Case Power Setting Parameter

The Worst Case Power Setting Parameter			
Test Software Version	DRTU		
Modulation Mode	2402 MHz	2440 MHz	2480 MHz
LE, 1Mbps	Defalut	Defalut	Defalut

2.3 The Worst Case Measurement Configuration

The Worst Case Mode for Following Conformance Tests	
Tests Item	AC power-line conducted emissions
Condition	AC power-line conducted measurement for line and neutral Test Voltage: 120Vac / 60Hz
Operating Mode	Operating Mode Description
1	Adapter mode and transmit

The Worst Case Mode for Following Conformance Tests	
Tests Item	RF Output Power, Power Spectral Density, 6 dB Bandwidth
Test Condition	Conducted measurement at transmit chains
Modulation Mode	LE-1Mbps

The Worst Case Mode for Following Conformance Tests			
Tests Item	Transmitter Radiated Unwanted Emissions Transmitter Radiated Bandedge Emissions		
Test Condition	Radiated measurement		
User Position	<input type="checkbox"/> EUT will be placed in fixed position.		
	<input checked="" type="checkbox"/> EUT will be placed in mobile position and operating multiple positions.		
	<input type="checkbox"/> EUT will be a hand-held or body-worn battery-powered devices and operating multiple positions.		
Operating Mode	Operating Mode Description		
1	Adapter mode and transmit		
Modulation Mode	LE-1Mbps		
Orthogonal Planes of EUT	X Plane	Y Plane	Z Plane
			
Worst Planes of EUT	V		

2.4 Test Setup Diagram

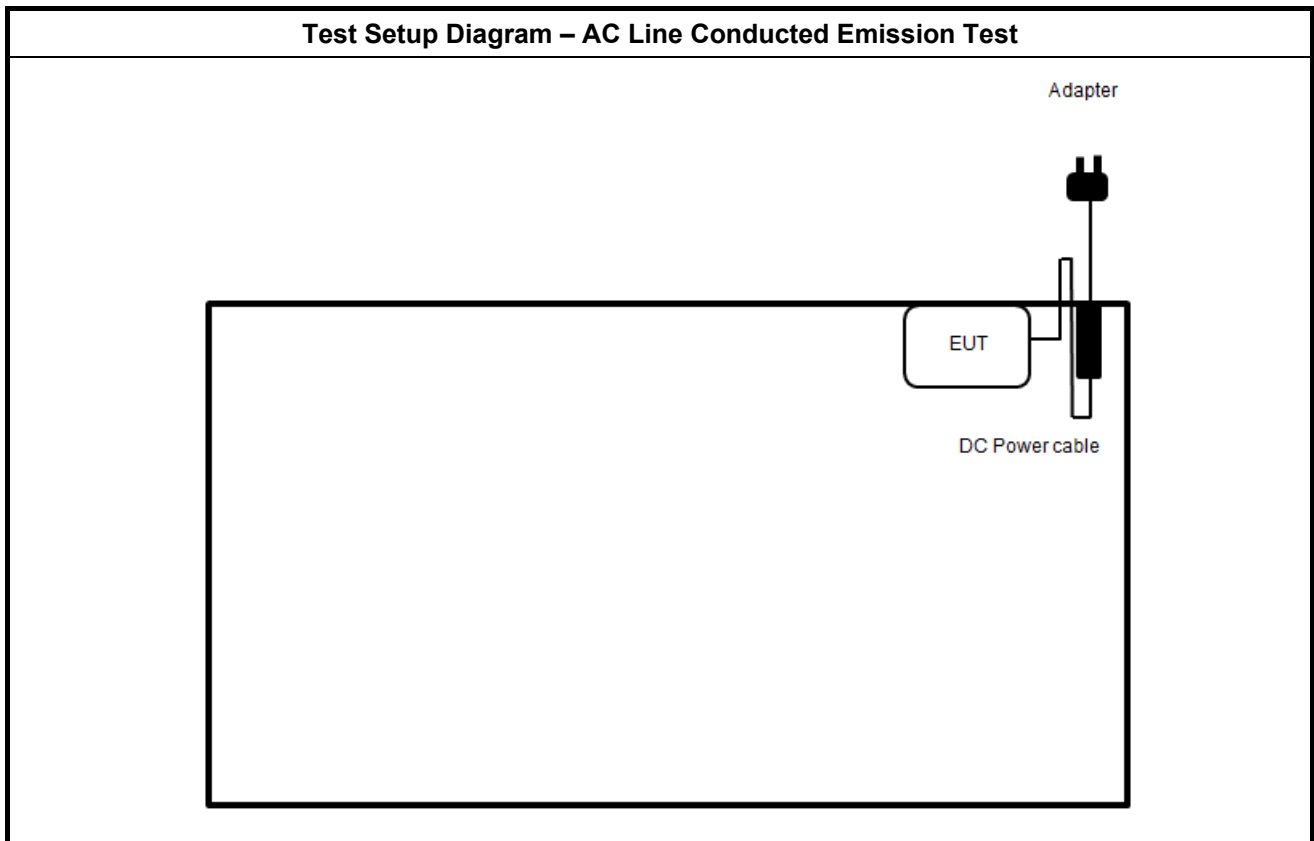

Test Setup Diagram - Radiated Test Below 1GHz

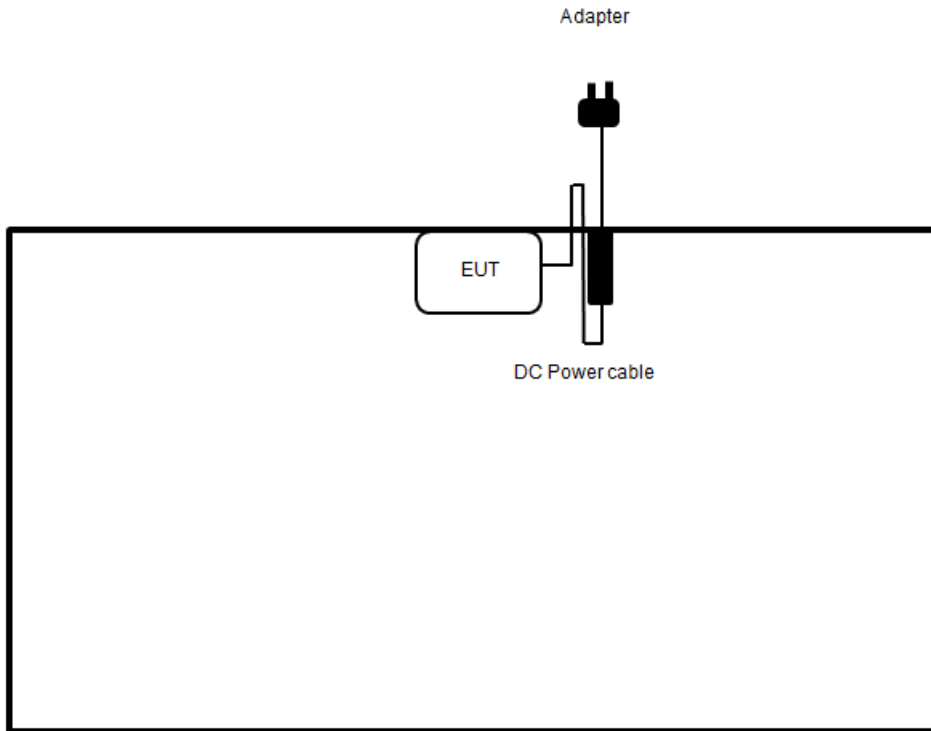

Test Setup Diagram - Radiated Test Above 1GHz

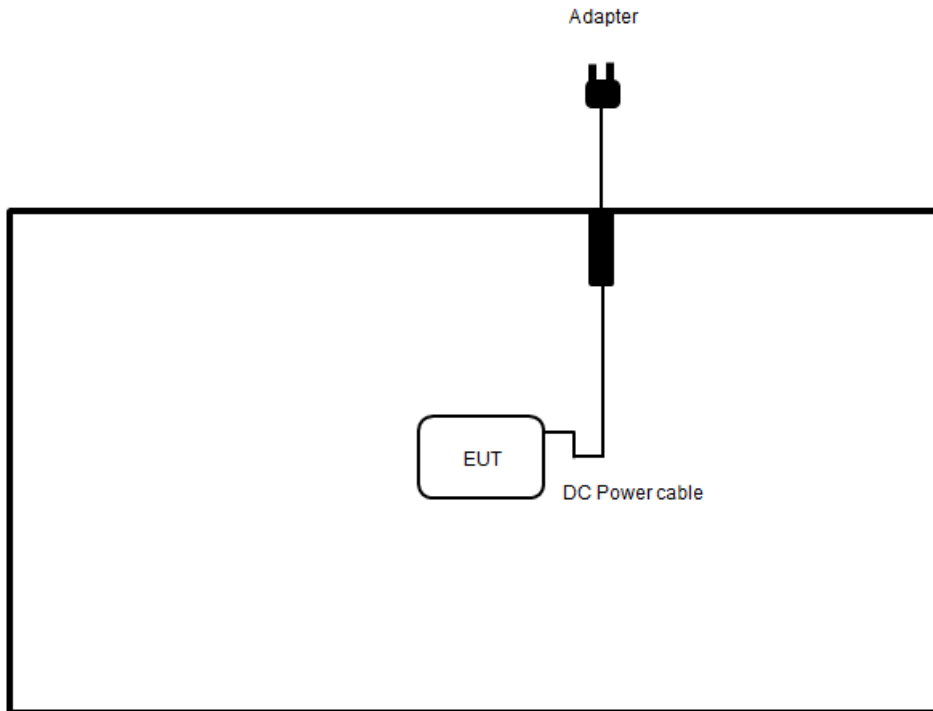

3 Transmitter Test Result

3.1 AC Power-line Conducted Emissions

3.1.1 AC Power-line Conducted Emissions Limit

AC Power-line Conducted Emissions Limit		
Frequency Emission (MHz)	Quasi-Peak	Average
0.15-0.5	66 - 56 *	56 - 46 *
0.5-5	56	46
5-30	60	50

Note 1: * Decreases with the logarithm of the frequency.

3.1.2 Measuring Instruments

Refer a test equipment and calibration data table in this test report.

3.1.3 Test Procedures

Test Method
<input checked="" type="checkbox"/> Refer as ANSI C63.10-2013, clause 6.2 for AC power-line conducted emissions.

3.1.4 Test Setup

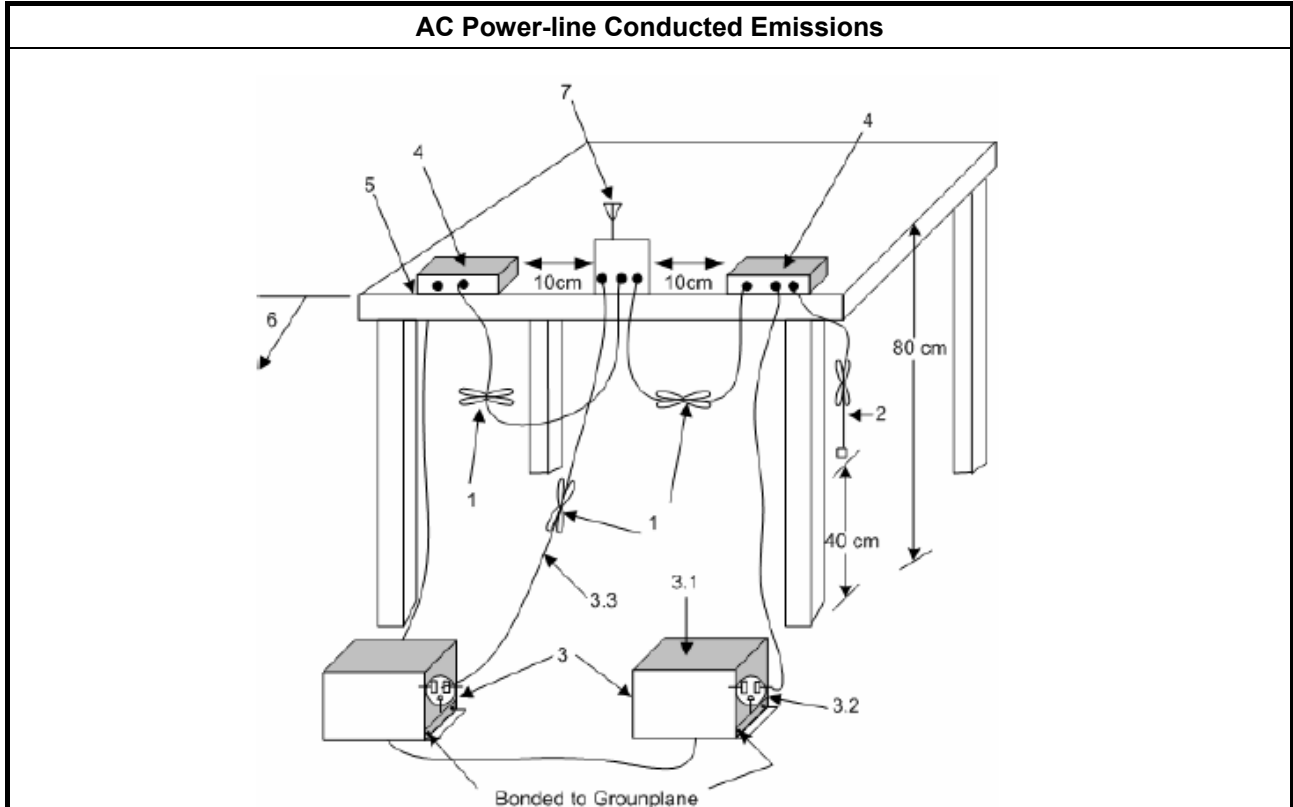

3.1.5 Test Result of AC Power-line Conducted Emissions

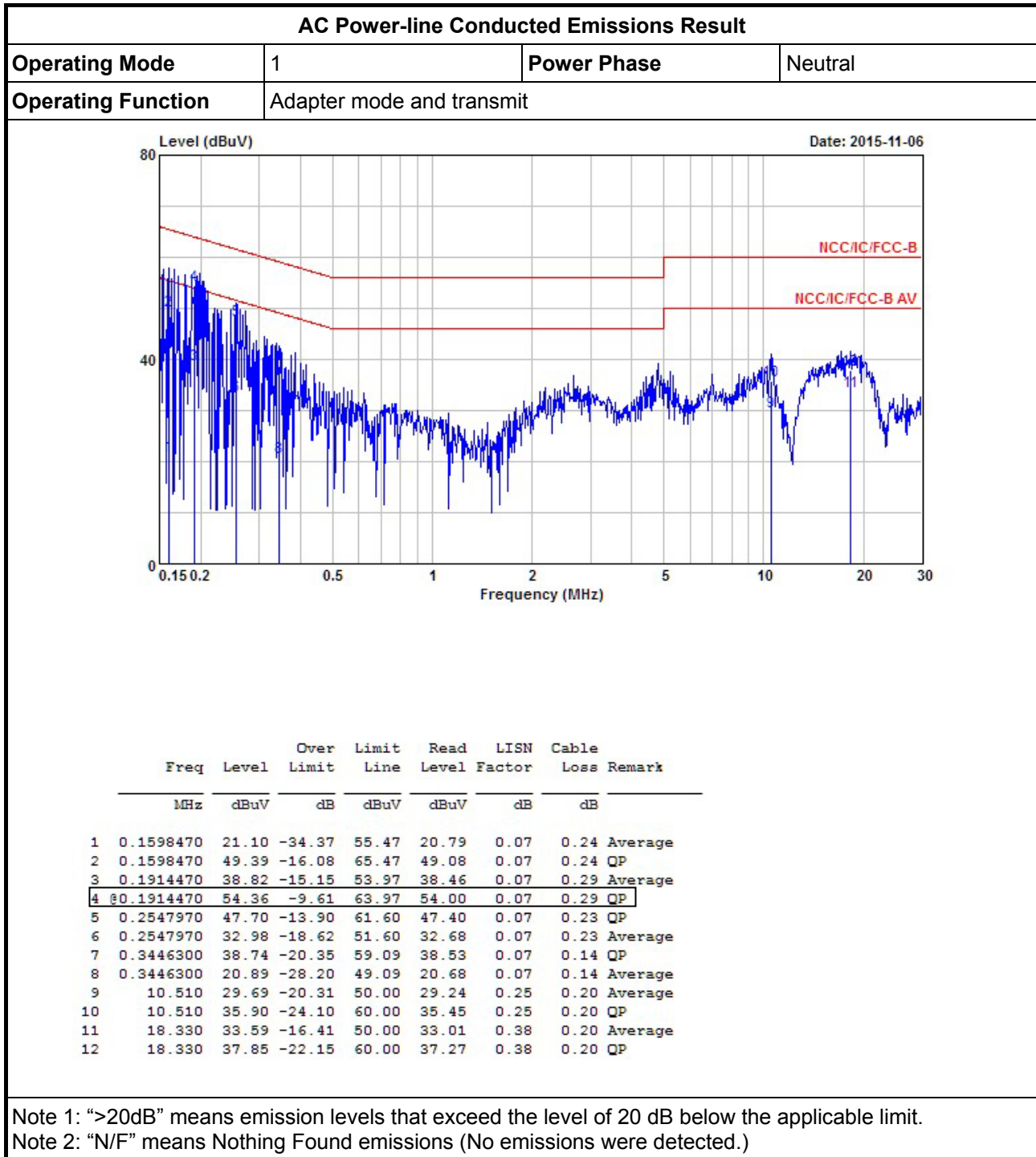

AC Power-line Conducted Emissions Result

Operating Mode	1	Power Phase	Line
Operating Function	Adapter mode and transmit		

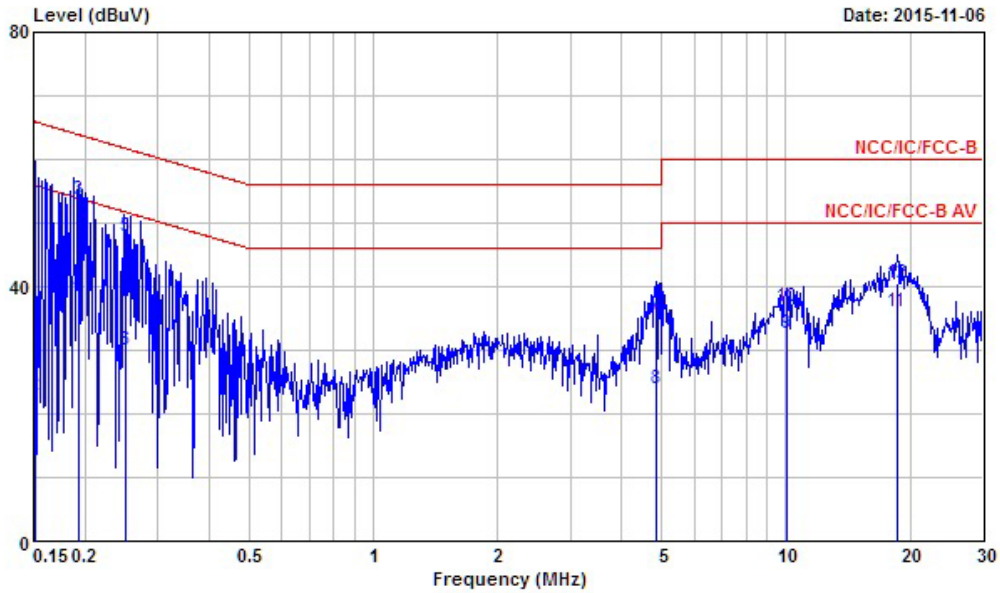

	Freq	Level	Over Limit	Limit Line	Read Level	LISN Factor	Cable Loss	Remark
	MHz	dBuV	dB	dBuV	dBuV	dB	dB	
1	0.1515980	50.71	-15.20	65.91	50.44	0.05	0.22	QP
2	0.1515980	22.94	-32.97	55.91	22.67	0.05	0.22	Average
3	0.1938850	53.64	-10.23	63.87	53.29	0.06	0.29	QP
4	0.1938850	38.95	-14.92	53.87	38.60	0.06	0.29	Average
5	0.2506540	47.90	-13.84	61.74	47.61	0.06	0.23	QP
6	0.2506540	30.00	-21.74	51.74	29.71	0.06	0.23	Average
7	4.850	35.41	-20.59	56.00	35.14	0.15	0.12	QP
8	4.850	23.90	-22.10	46.00	23.63	0.15	0.12	Average
9	10.020	32.68	-17.32	50.00	32.25	0.23	0.20	Average
10	10.020	36.91	-23.09	60.00	36.48	0.23	0.20	QP
11	18.620	36.10	-13.90	50.00	35.55	0.35	0.20	Average
12	18.620	40.43	-19.57	60.00	39.88	0.35	0.20	QP

Note 1: ">20dB" means emission levels that exceed the level of 20 dB below the applicable limit.
 Note 2: "N/F" means Nothing Found emissions (No emissions were detected.)

3.2 6dB Bandwidth

3.2.1 6dB Bandwidth Limit

6dB Bandwidth Limit	
Systems using digital modulation techniques:	
<input checked="" type="checkbox"/>	6 dB bandwidth \geq 500 kHz.

3.2.2 Measuring Instruments

Refer a test equipment and calibration data table in this test report.

3.2.3 Test Procedures

Test Method	
<input checked="" type="checkbox"/>	For the emission bandwidth shall be measured using one of the options below:
<input checked="" type="checkbox"/>	Refer as FCC KDB 558074 D01 v03r03, clause 8.1 Option 1 for 6 dB bandwidth measurement.
<input type="checkbox"/>	Refer as FCC KDB 558074 D01 v03r03, clause 8.2 Option 2 for 6 dB bandwidth measurement.
<input type="checkbox"/>	Refer as ANSI C63.10, clause 6.9.1 for occupied bandwidth testing.
<input checked="" type="checkbox"/>	For conducted measurement.
<input checked="" type="checkbox"/>	The EUT supports single transmit chain and measurements performed on this transmit chain.
<input type="checkbox"/>	The EUT supports diversity transmitting and the results on transmit chain port 1 is the worst case.

3.2.4 Test Setup

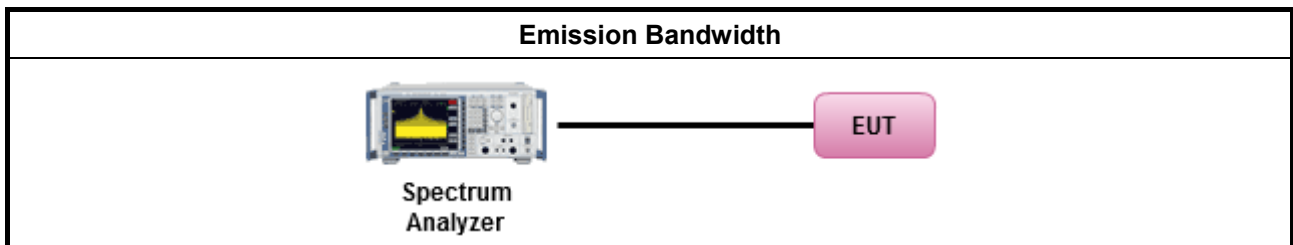

3.2.5 Test Result of Emission Bandwidth

Emission Bandwidth Result			
Modulation Mode	Freq. (MHz)	99% Bandwidth (kHz)	6dB Bandwidth (kHz)
LE-1Mbps	2402	1054.99	651.20
LE-1Mbps	2440	1059.33	655.60
LE-1Mbps	2480	1059.33	664.30
Limit		N/A	≥500 kHz
Result		Complied	

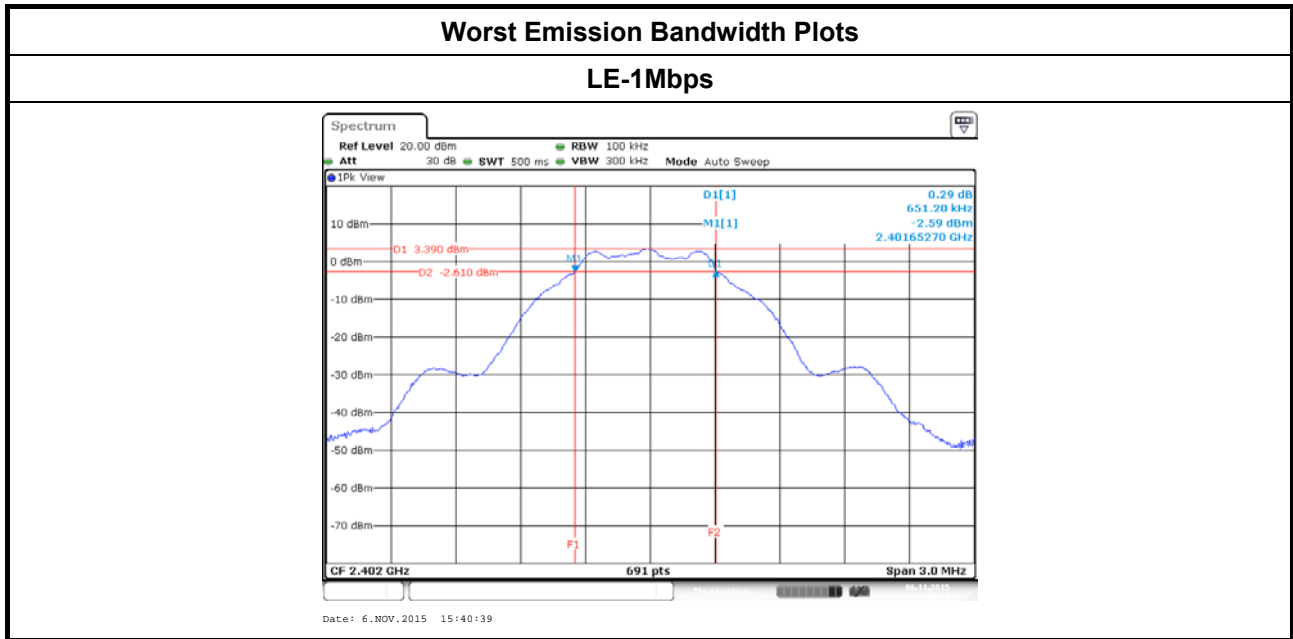

3.3 RF Output Power

3.3.1 RF Output Power Limit

RF Output Power Limit for Digital Modulation Systems	
Maximum Peak Conducted Output Power or Maximum Conducted Output Power Limit	
<input checked="" type="checkbox"/> 2400-2483.5 MHz Band:	
<input checked="" type="checkbox"/>	If $G_{TX} \leq 6$ dBi, then $P_{Out} \leq 30$ dBm (1 W)
<input type="checkbox"/>	Point-to-multipoint systems (P2M): If $G_{TX} > 6$ dBi, then $P_{Out} = 30 - (G_{TX} - 6)$ dBm
e.i.r.p. Power Limit:	
<input checked="" type="checkbox"/> 2400-2483.5 MHz Band	
<input checked="" type="checkbox"/>	Point-to-multipoint systems (P2M): $P_{eirp} \leq 36$ dBm (4 W)
P_{Out} = maximum peak conducted output power or maximum conducted output power in dBm, G_{TX} = the maximum transmitting antenna directional gain in dBi. P_{eirp} = e.i.r.p. Power in dBm.	

3.3.2 Measuring Instruments

Refer a test equipment and calibration data table in this test report.

3.3.3 Test Procedures

Test Method	
<input checked="" type="checkbox"/> Maximum Peak Conducted Output Power	
<input checked="" type="checkbox"/>	Refer as ANSI C63.10, clause 11.9.1.3) for peak power meter.
<input type="checkbox"/>	Refer as ANSI C63.10, clause 11.9.1.1) for spectrum analyzer - (RBW \geq EBW).
<input checked="" type="checkbox"/> For conducted measurement.	
<input checked="" type="checkbox"/>	The EUT supports single transmit chain and measurements performed on this transmit chain.
<input type="checkbox"/>	The EUT supports diversity transmitting and the results on transmit chain port 1 is the worst case.

3.3.4 Test Setup

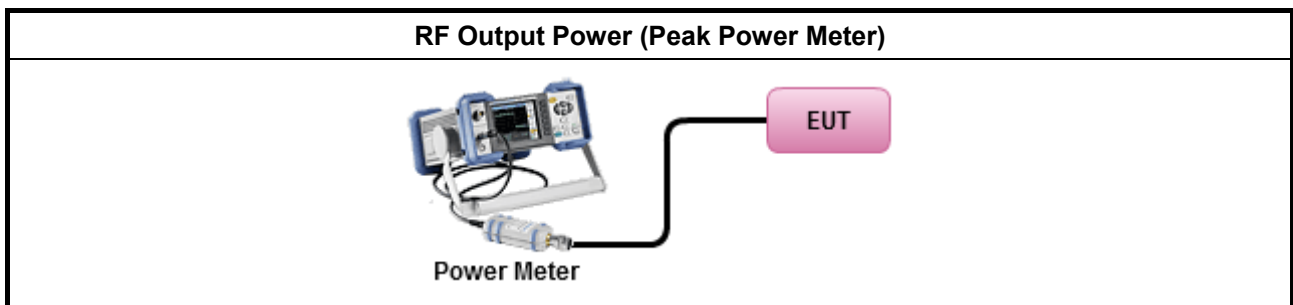

3.3.5 Test Result of Maximum Peak Conducted Output Power

Maximum Peak Conducted Output Power Result						
Condition		RF Output Power (dBm)				
Modulation Mode	Freq. (MHz)	RF Output Power	Power Limit	Antenna Gain (dBi)	EIRP Power	EIRP Limit
LE-1Mbps	2402	4.85	30	2.00	6.85	36
LE-1Mbps	2440	5.57	30	2.00	7.57	36
LE-1Mbps	2480	6.1	30	2.00	8.10	36
Result		Complied				

3.3.6 Test Result of Maximum Average Conducted Output Power

Maximum Average Conducted Output Power Result						
Condition		RF Output Power (dBm)				
Modulation Mode	Freq. (MHz)	Average Power	Duty Factor (dB)	RF Output Power	Antenna Gain (dBi)	EIRP Power
LE-1Mbps	2402	2.82	1.32	4.14	2.00	6.14
LE-1Mbps	2440	3.51	1.32	4.83	2.00	6.83
LE-1Mbps	2480	4.07	1.32	5.39	2.00	7.39
Result		Complied				

3.4 Power Spectral Density

3.4.1 Power Spectral Density Limit

Power Spectral Density Limit
<input checked="" type="checkbox"/> Power Spectral Density (PSD) \leq 8 dBm/3kHz

3.4.2 Measuring Instruments

Refer a test equipment and calibration data table in this test report.

3.4.3 Test Procedures

Test Method
<input checked="" type="checkbox"/> Peak power spectral density procedures that the same method as used to determine the conducted output power. If maximum peak conducted output power was measured to demonstrate compliance to the output power limit, then the peak PSD procedure below (Method PKPSD) shall be used. If maximum conducted output power was measured to demonstrate compliance to the output power limit, then one of the average PSD procedures shall be used, as applicable based on the following criteria (the peak PSD procedure is also an acceptable option).
<input checked="" type="checkbox"/> Refer as FCC KDB 558074 D01 v03r03, clause 10.2 Method PKPSD (RBW=3-100kHz;detector=peak)..
[duty cycle \geq 98% or external video / power trigger]
<input type="checkbox"/> Refer as FCC KDB 558074 D01 v03r03, clause 10.3 Method AVGPSD-1 (spectral trace averaging).
<input type="checkbox"/> Refer as FCC KDB 558074 D01 v03r03, clause 10.4 Method AVGPSD-1 Alt. (slow sweep speed)
duty cycle < 98% and average over on/off periods with duty factor
<input checked="" type="checkbox"/> Refer as FCC KDB 558074 D01 v03r03, clause 10.5 Method AVGPSD-2 (spectral trace averaging).
<input type="checkbox"/> Refer as FCC KDB 558074 D01 v03r03, clause 10.6 Method AVGPSD-2 Alt. (slow sweep speed)
<input checked="" type="checkbox"/> For conducted measurement.
<input checked="" type="checkbox"/> The EUT supports single transmit chain and measurements performed on this transmit chain.
<input type="checkbox"/> The EUT supports diversity transmitting and the results on transmit chain port 1 is the worst case.

3.4.4 Test Setup

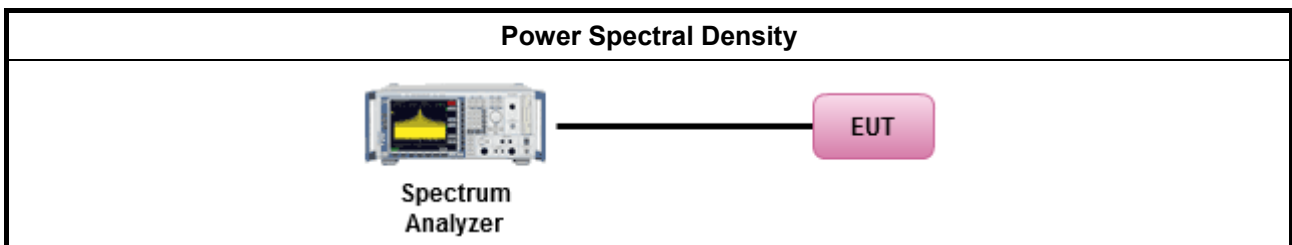



3.4.5 Test Result of Power Spectral Density

Power Spectral Density Result			
Modulation Mode	Freq. (MHz)	PSD (dBm/100kHz)	PSD Limit (dBm/3kHz)
LE-1Mbps	2402	-11.26	8
LE-1Mbps	2440	-10.42	8
LE-1Mbps	2480	-10.30	8
Result		Complied	

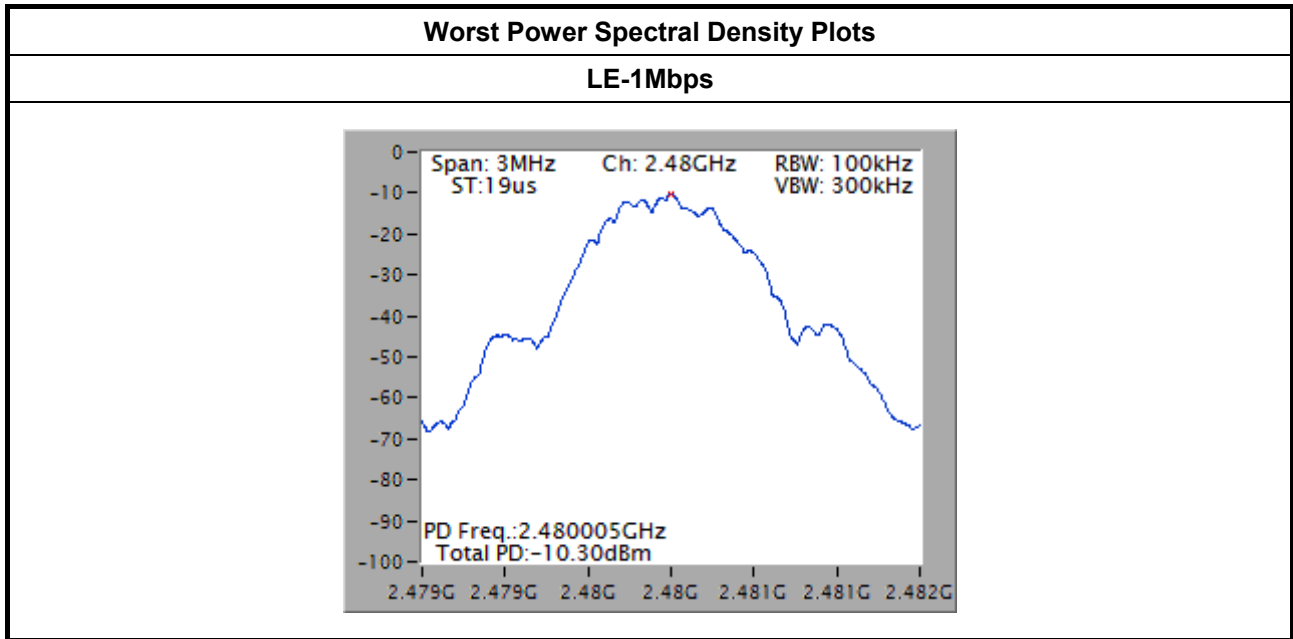

Note: 15.2dBm has been offset for 3kHz data.

3.5 Transmitter Bandedge Emissions

3.5.1 Transmitter Radiated Bandedge Emissions Limit

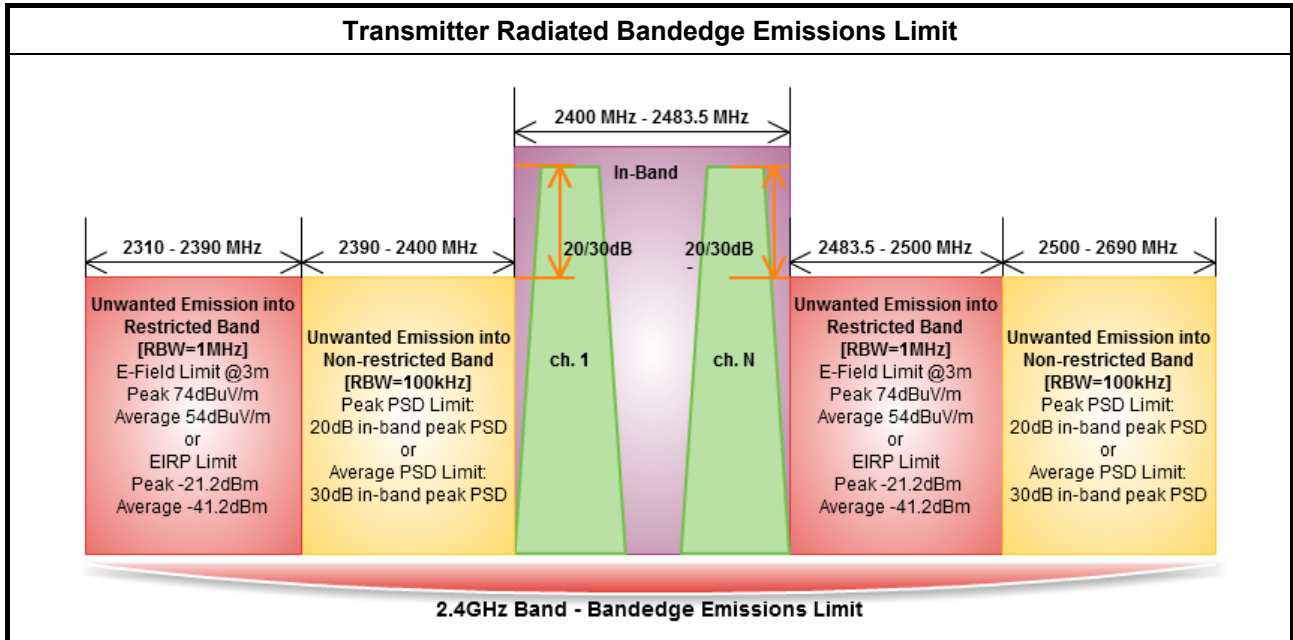

3.5.2 Measuring Instruments

Refer a test equipment and calibration data table in this test report.



3.5.3 Test Procedures

Test Method	
<input checked="" type="checkbox"/>	The average emission levels shall be measured in [duty cycle \geq 98 or duty factor].
<input checked="" type="checkbox"/>	Refer as ANSI C63.10, clause 6.10 bandedge testing shall be performed at the lowest frequency channel and highest frequency channel within the allowed operating band.
<input checked="" type="checkbox"/>	For the transmitter unwanted emissions shall be measured using following options below:
<input checked="" type="checkbox"/>	Refer as FCC KDB 558074 D01 v03r03, clause 11 for unwanted emissions into non-restricted bands.
<input checked="" type="checkbox"/>	Refer as FCC KDB 558074 D01 v03r03, clause 12 for unwanted emissions into restricted bands.
<input type="checkbox"/>	Refer as FCC KDB 558074 D01 v03r03, clause 12.2.5.1 Option 1 (trace averaging for duty cycle \geq 98%)
<input type="checkbox"/>	Refer as FCC KDB 558074 D01 v03r03, clause 12.2.5.2 Option 2 (trace averaging + duty factor).
<input checked="" type="checkbox"/>	Refer as FCC KDB 558074 D01 v03r03, clause 12.2.5.3 Option 3 (Reduced VBW \geq 1/T).
<input type="checkbox"/>	Refer as ANSI C63.10, clause 4.1.4.2.3 (Reduced VBW). VBW \geq 1/T, where T is pulse time.
<input type="checkbox"/>	Refer as ANSI C63.10, clause 4.1.4.2.4 average value of pulsed emissions.
<input checked="" type="checkbox"/>	Refer as FCC KDB 558074 D01 v03r03, clause 11.3 and 12.2.4 measurement procedure peak limit.
<input checked="" type="checkbox"/>	For the transmitter bandedge emissions shall be measured using following options below:
<input type="checkbox"/>	Refer as FCC KDB 558074 D01 v03r03, clause 13.3 for narrower resolution bandwidth (100kHz) using the band power and summing the spectral levels (i.e., 1 MHz).
<input checked="" type="checkbox"/>	Refer as ANSI C63.10, clause 6.10 for band-edge testing.
<input type="checkbox"/>	Refer as ANSI C63.10, clause 6.10.6.2 for marker-delta method for band-edge measurements.
<input checked="" type="checkbox"/>	For radiated measurement, refer as FCC KDB 558074 D01 v03r03, clause 12.2.7 and ANSI C63.10, clause 6.6. Test distance is 3m.
<input type="checkbox"/>	For conducted measurement, refer as FCC KDB 558074 D01 v03r03, clause 12.2.2.

3.5.4 Test Setup

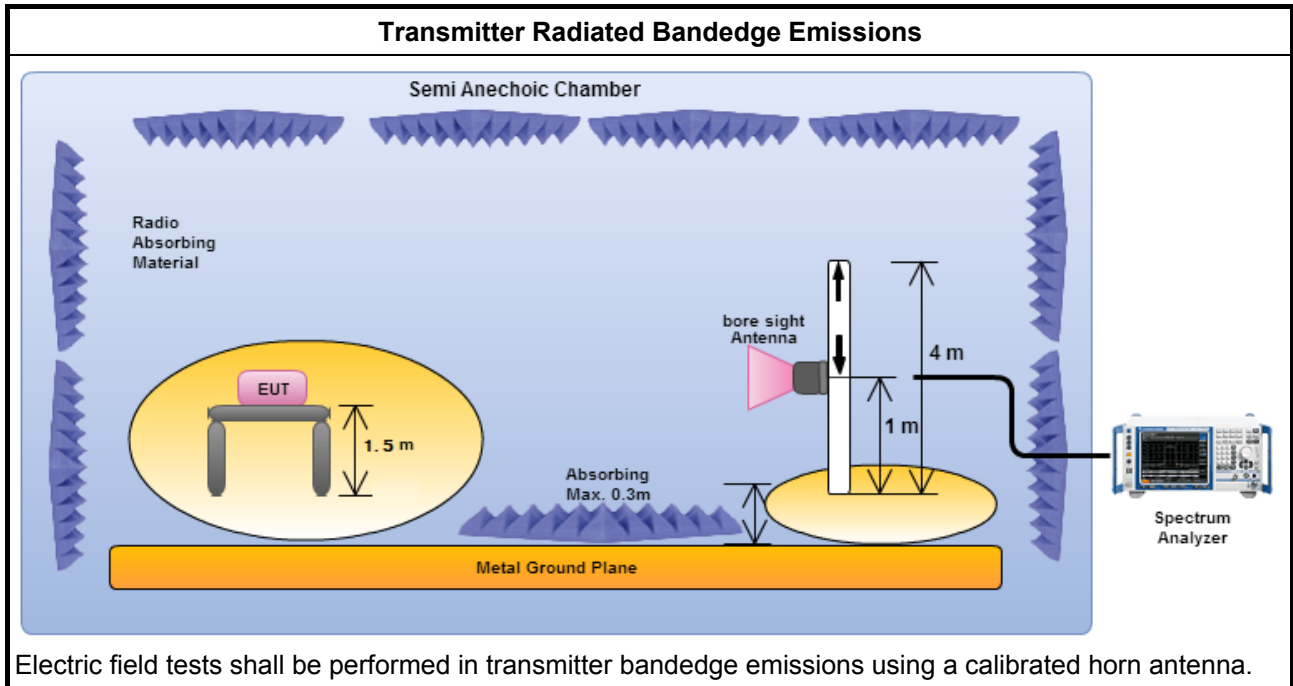

3.5.5 Transmitter Radiated Bandedge Emissions

2400-2483.5MHz Transmitter Radiated Bandedge Emissions (Non-restricted Band)								
Modulation	N _{TX}	Test Freq. (MHz)	In-band PSD [i] (dBuV/100kHz)	Freq. (MHz)	Out-band PSD [o] (dBuV/100kHz)	[i] - [o] (dB)	Limit (dB)	Pol.
LE-1Mbps	1	2402	98.83	2399.96	53.35	45.48	20	V
LE-1Mbps	1	2480	100.04	2548.64	46.84	53.20	20	V

Note 1: Measurement worst emissions of receive antenna polarization

2400-2483.5MHz Transmitter Radiated Bandedge Emissions (Restricted Band)										
Modulation Mode	N _{TX}	Freq. (MHz)	Measure Distance (m)	Freq. (MHz) PK	Level (dBuV/m) PK	Limit (dBuV/m) PK	Freq. (MHz) AV	Level (dBuV/m) AV	Limit (dBuV/m) AV	Pol.
LE-1Mbps	1	2402	3	2389.39	55.33	74	2389.15	42.35	54	V
LE-1Mbps	1	2480	3	2485.28	57.54	74	2484.64	44.76	54	V

Note 1: Measurement worst emissions of receive antenna polarization.
 Note 2: Average emission setting: RBW=1MHz; VBW ≥ 1/T, where T is "Pulse On Time", e.g., LE VBW ≥ 1/625us, VBW=3kHz.

3.6 Transmitter Unwanted Emissions

3.6.1 Transmitter Radiated Unwanted Emissions Limit

Restricted Band Emissions Limit			
Frequency Range (MHz)	Field Strength (uV/m)	Field Strength (dBuV/m)	Measure Distance (m)
0.009~0.490	2400/F(kHz)	48.5 - 13.8	300
0.490~1.705	24000/F(kHz)	33.8 - 23	30
1.705~30.0	30	29	30
30~88	100	40	3
88~216	150	43.5	3
216~960	200	46	3
Above 960	500	54	3

Note 1: Test distance for frequencies at or above 30 MHz, measurements may be performed at a distance other than the limit distance provided they are not performed in the near field and the emissions to be measured can be detected by the measurement equipment. When performing measurements at a distance other than that specified, the results shall be extrapolated to the specified distance using an extrapolation factor of 20 dB/decade (inverse of linear distance for field-strength measurements, inverse of linear distance-squared for power-density measurements).

Note 2: Test distance for frequencies at below 30 MHz, measurements may be performed at a distance closer than the EUT limit distance; however, an attempt should be made to avoid making measurements in the near field. When performing measurements below 30 MHz at a closer distance than the limit distance, the results shall be extrapolated to the specified distance by either making measurements at a minimum of two or more distances on at least one radial to determine the proper extrapolation factor or by using the square of an inverse linear distance extrapolation factor (40 dB/decade). The test report shall specify the extrapolation method used to determine compliance of the EUT.

Un-restricted Band Emissions Limit	
RF output power procedure	Limit (dB)
Peak output power procedure	20
Average output power procedure	30

Note 1: If the peak output power procedure is used to measure the fundamental emission power to demonstrate compliance to requirements, then the peak conducted output power measured within any 100 kHz outside the authorized frequency band shall be attenuated by at least 20 dB relative to the maximum measured in-band peak PSD level.

Note 2: If the average output power procedure is used to measure the fundamental emission power to demonstrate compliance to requirements, then the power in any 100 kHz outside of the authorized frequency band shall be attenuated by at least 30 dB relative to the maximum measured in-band average PSD level.

3.6.2 Measuring Instruments

Refer a test equipment and calibration data table in this test report.

3.6.3 Test Procedures

Test Method	
<input checked="" type="checkbox"/>	Measurements may be performed at a distance other than the limit distance provided they are not performed in the near field and the emissions to be measured can be detected by the measurement equipment. When performing measurements at a distance other than that specified, the results shall be extrapolated to the specified distance using an extrapolation factor of 20 dB/decade (inverse of linear distance for field-strength measurements, inverse of linear distance-squared for power-density measurements).
<input checked="" type="checkbox"/>	The average emission levels shall be measured in [duty cycle \geq 98 or duty factor].
<input checked="" type="checkbox"/>	For the transmitter unwanted emissions shall be measured using following options below:
<input checked="" type="checkbox"/>	Refer as FCC KDB 558074 D01 v03r03, clause 11 for unwanted emissions into non-restricted bands.
<input checked="" type="checkbox"/>	Refer as FCC KDB 558074 D01 v03r03, clause 12 for unwanted emissions into restricted bands.
<input type="checkbox"/>	Refer as FCC KDB 558074 D01 v03r03, clause 12.2.5.1 Option 1 (trace averaging for duty cycle \geq 98%)
<input type="checkbox"/>	Refer as FCC KDB 558074 D01 v03r03, clause 12.2.5.2 Option 2 (trace averaging + duty factor).
<input checked="" type="checkbox"/>	Refer as FCC KDB 558074 D01 v03r03, clause 12.2.5.3 Option 3 (Reduced VBW \geq 1/T).
<input type="checkbox"/>	Refer as ANSI C63.10, clause 4.1.4.2.3 (Reduced VBW). VBW \geq 1/T, where T is pulse time.
<input type="checkbox"/>	Refer as ANSI C63.10, clause 4.1.4.2.4 average value of pulsed emissions.
<input checked="" type="checkbox"/>	Refer as FCC KDB 558074 D01 v03r03, clause 11.3 and 12.2.4 measurement procedure peak limit.
<input checked="" type="checkbox"/>	Refer as FCC KDB 558074 D01 v03r03, clause 12.2.3 measurement procedure Quasi-Peak limit.
<input checked="" type="checkbox"/>	For radiated measurement, refer as FCC KDB 558074 D01 v03r03, clause 12.2.7.
<input checked="" type="checkbox"/>	Refer as ANSI C63.10, clause 6.4 for radiated emissions below 30 MHz and test distance is 3m.
<input checked="" type="checkbox"/>	Refer as ANSI C63.10, clause 6.5 for radiated emissions 30 MHz to 1 GHz and test distance is 3m.
<input checked="" type="checkbox"/>	Refer as ANSI C63.10, clause 6.6 for radiated emissions above 1 GHz and test distance is 3m.
<input type="checkbox"/>	For conducted and cabinet radiation measurement, refer as FCC KDB 558074 D01 v03r03, clause 12.2.2.

3.6.4 Test Setup

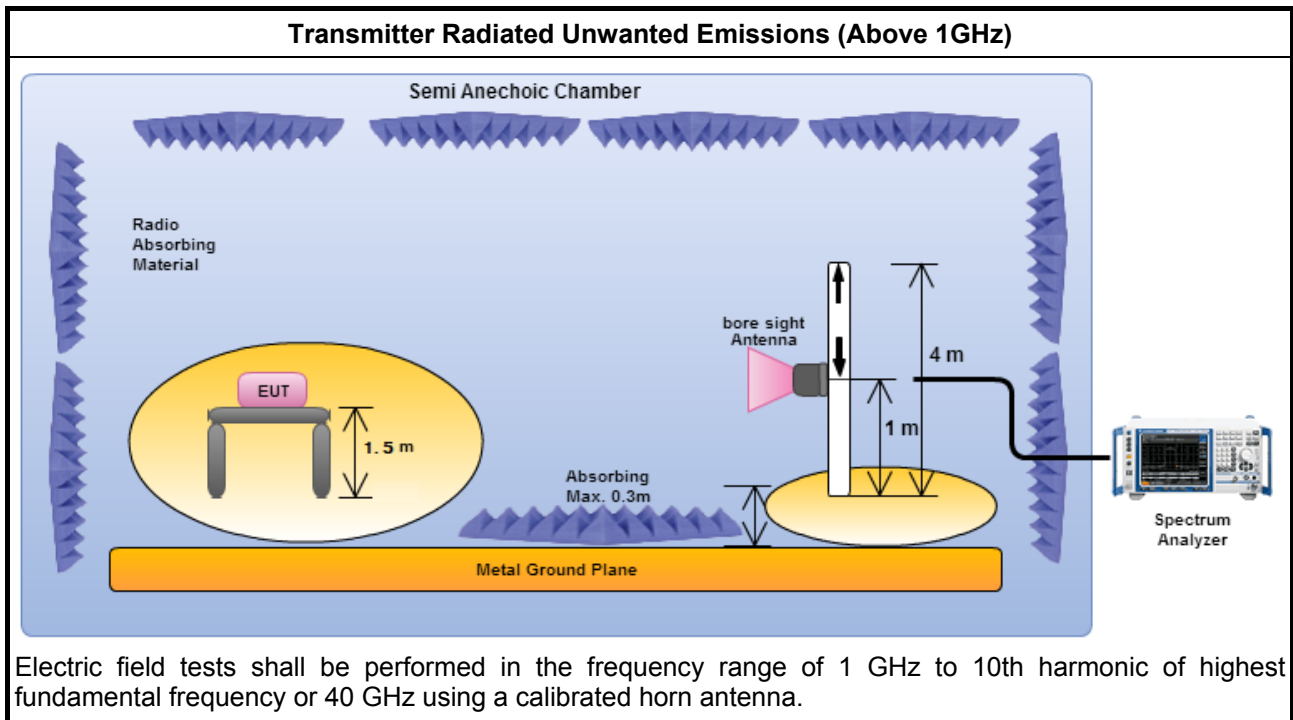
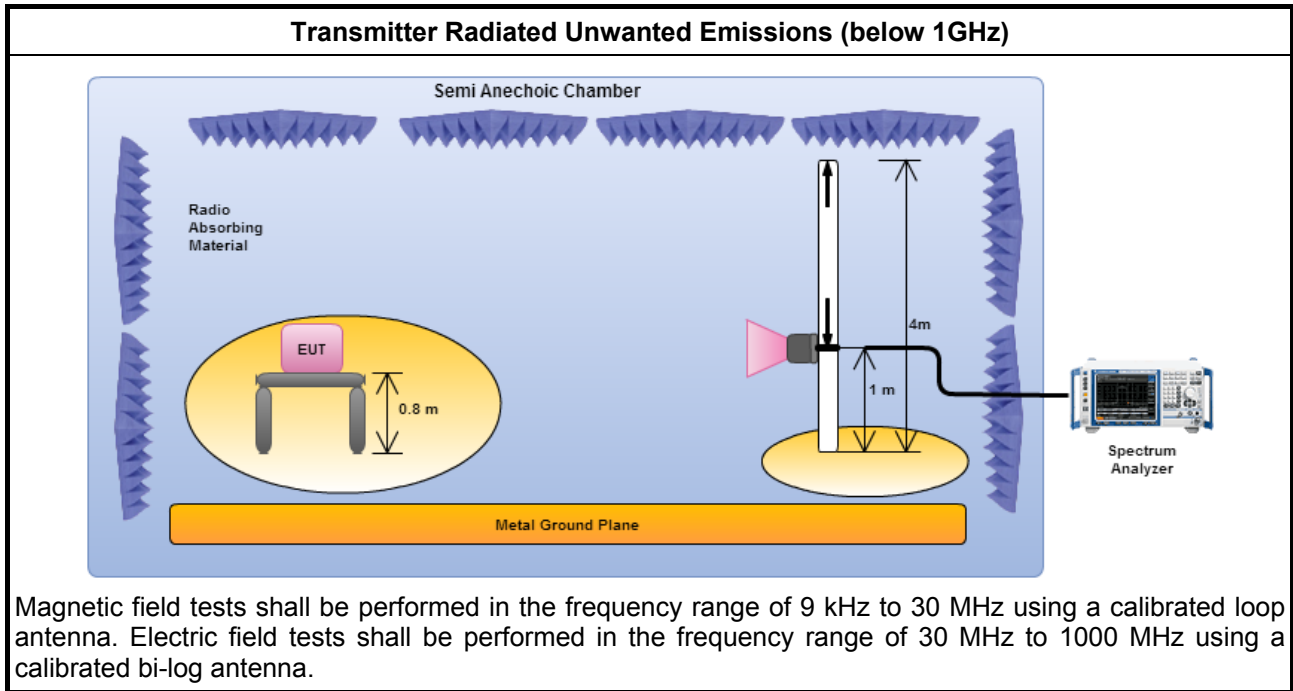

3.6.5 Transmitter Radiated Unwanted Emissions (Below 30MHz)

All amplitude of spurious emissions that are attenuated by more than 20 dB below the permissible value has no need to be reported.



3.6.6 Transmitter Radiated Unwanted Emissions (Below 1GHz)

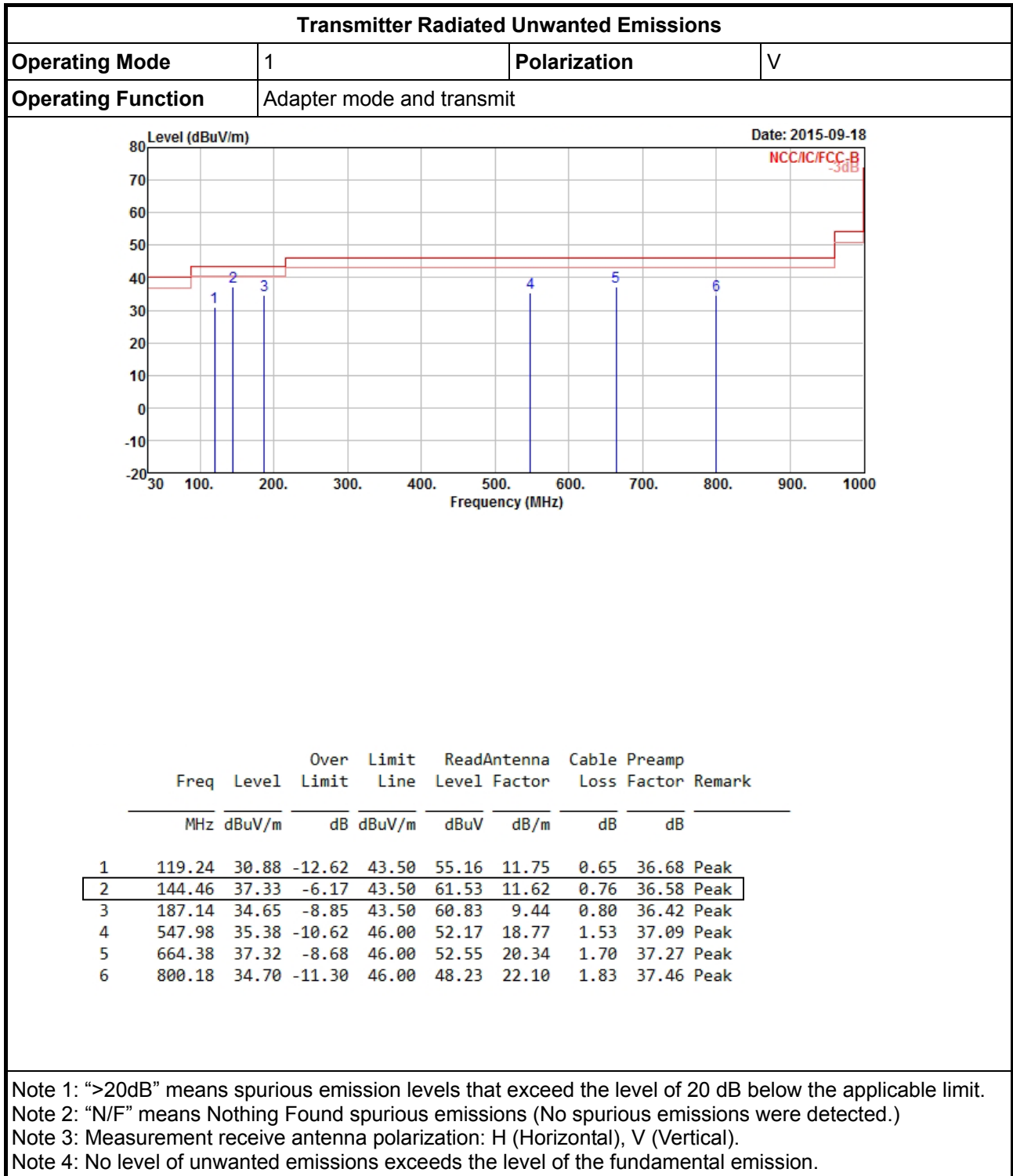



Transmitter Radiated Unwanted Emissions

Operating Mode	1	Polarization	H
Operating Function	Adapter mode and transmit		

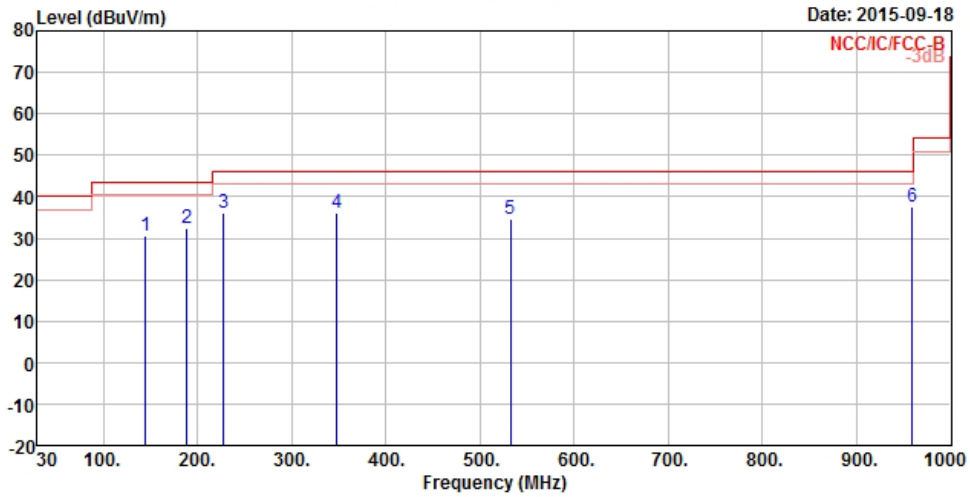

	Freq	Level	Over Limit	Limit Line	ReadAntenna Level	Cable Loss	Preamp Factor	Remark
	MHz	dBUV/m	dB	dBUV/m	dBuV	dB/m	dB	
1	144.46	30.43	-13.07	43.50	54.63	11.62	0.76	36.58 Peak
2	189.08	32.30	-11.20	43.50	58.42	9.48	0.81	36.41 Peak
3	227.88	36.11	-9.89	46.00	60.72	10.84	0.93	36.38 Peak
4	348.16	36.09	-9.91	46.00	56.26	15.14	1.17	36.48 Peak
5	532.46	34.75	-11.25	46.00	51.75	18.55	1.50	37.05 Peak
6	959.26	37.50	-8.50	46.00	48.15	24.68	2.05	37.38 Peak

Note 1: ">20dB" means spurious emission levels that exceed the level of 20 dB below the applicable limit.
 Note 2: "N/F" means Nothing Found spurious emissions (No spurious emissions were detected.)
 Note 3: Measurement receive antenna polarization: H (Horizontal), V (Vertical).
 Note 4: No level of unwanted emissions exceeds the level of the fundamental emission.

3.6.7 Transmitter Radiated Unwanted Emissions (Above 1GHz)

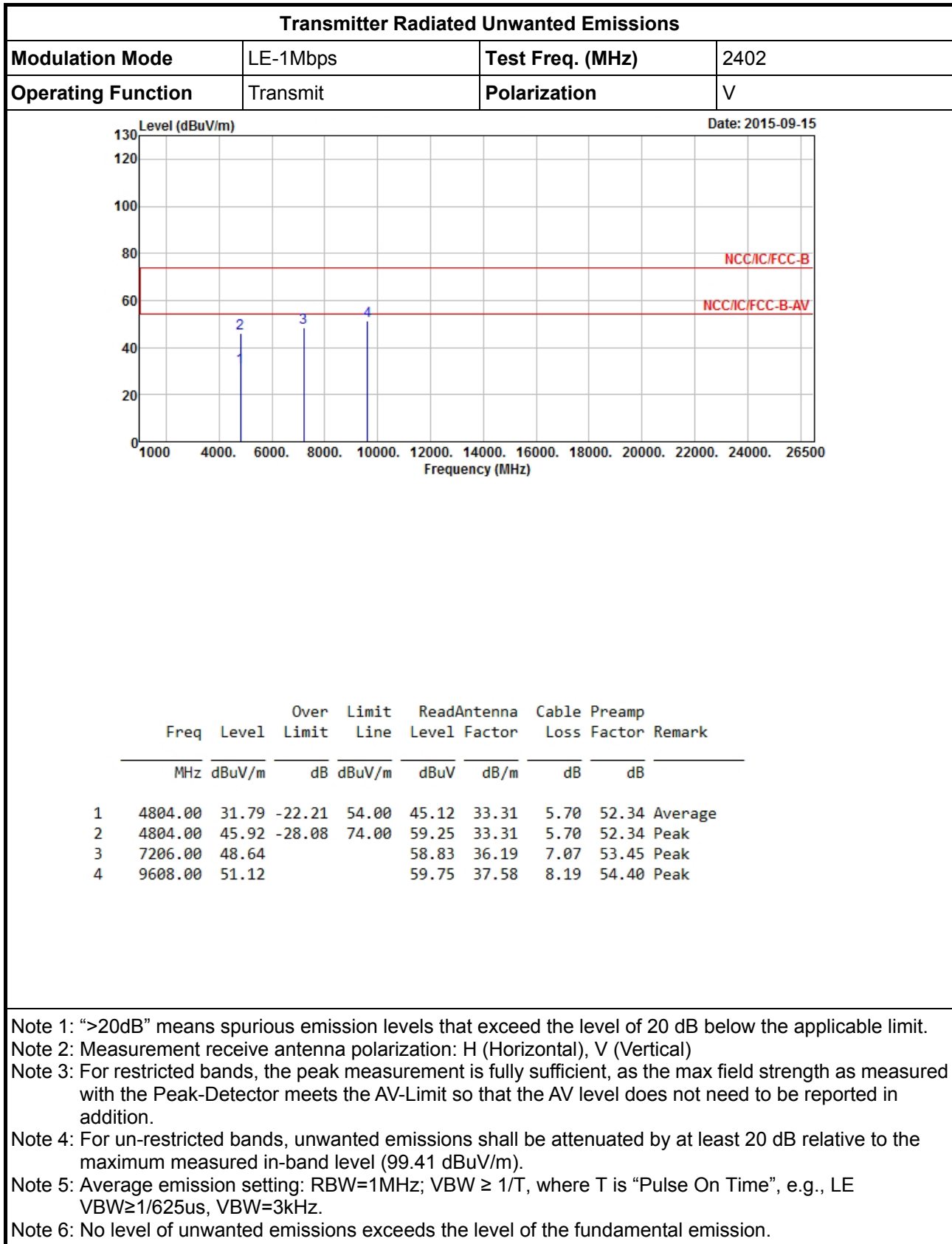



Transmitter Radiated Unwanted Emissions			
Modulation Mode	LE-1Mbps	Test Freq. (MHz)	2402
Operating Function	Transmit	Polarization	H

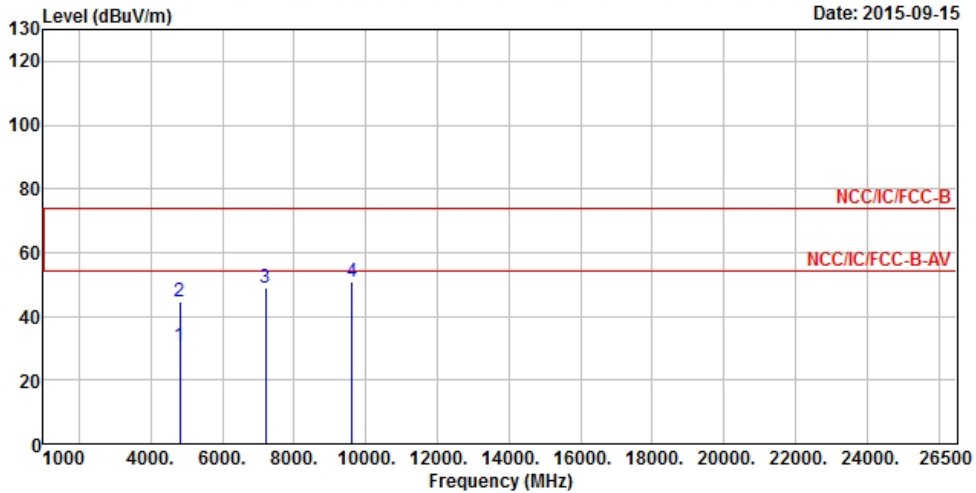

	Freq	Level	Over Limit	Limit Line	ReadAntenna Level	Antenna Factor	Cable Loss	Preamp Factor	Remark
	MHz	dBuV/m	dB	dBuV/m	dBuV	dB/m	dB	dB	
1	4804.00	30.82	-23.18	54.00	44.15	33.31	5.70	52.34	Average
2	4804.00	44.58	-29.42	74.00	57.91	33.31	5.70	52.34	Peak
3	7206.00	48.76			58.95	36.19	7.07	53.45	Peak
4	9608.00	50.69			59.32	37.58	8.19	54.40	Peak

- Note 1: ">20dB" means spurious emission levels that exceed the level of 20 dB below the applicable limit.
- Note 2: Measurement receive antenna polarization: H (Horizontal), V (Vertical)
- Note 3: For restricted bands, the peak measurement is fully sufficient, as the max field strength as measured with the Peak-Detector meets the AV-Limit so that the AV level does not need to be reported in addition.
- Note 4: For un-restricted bands, unwanted emissions shall be attenuated by at least 20 dB relative to the maximum measured in-band level (99.41 dBuV/m).
- Note 5: Average emission setting: RBW=1MHz; VBW ≥ 1/T, where T is "Pulse On Time", e.g., LE VBW≥1/625us, VBW=3kHz.
- Note 6: No level of unwanted emissions exceeds the level of the fundamental emission.



Transmitter Radiated Unwanted Emissions			
Modulation Mode	LE-1Mbps	Test Freq. (MHz)	2440
Operating Function	Transmit	Polarization	V

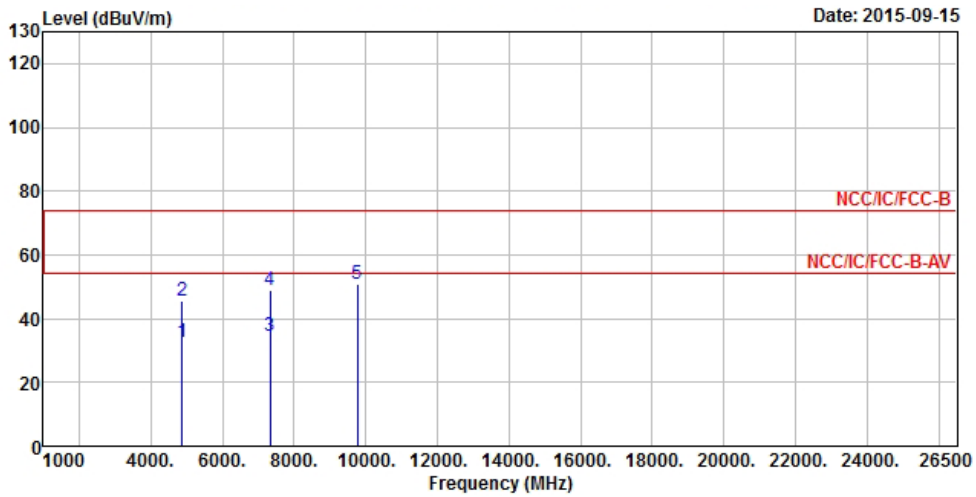

	Freq	Level	Over	Limit	ReadAntenna	Cable	Preamp	Remark
	MHz	dBuV/m	Limit	Line	Level	Loss	Factor	
			dB	dBuV/m	dBuV	dB/m	dB	dB
1	4880.00	32.58	-21.42	54.00	45.84	33.38	5.72	52.36 Average
2	4880.00	45.56	-28.44	74.00	58.82	33.38	5.72	52.36 Peak
3	7320.00	34.50	-19.50	54.00	44.51	36.36	7.14	53.51 Average
4	7320.00	49.00	-25.00	74.00	59.01	36.36	7.14	53.51 Peak
5	9760.00	50.82			59.35	37.55	8.28	54.36 Peak

- Note 1: ">20dB" means spurious emission levels that exceed the level of 20 dB below the applicable limit.
- Note 2: Measurement receive antenna polarization: H (Horizontal), V (Vertical)
- Note 3: For restricted bands, the peak measurement is fully sufficient, as the max field strength as measured with the Peak-Detector meets the AV-Limit so that the AV level does not need to be reported in addition.
- Note 4: For un-restricted bands, unwanted emissions shall be attenuated by at least 20 dB relative to the maximum measured in-band level (99.64 dBuV/m).
- Note 5: Average emission setting: RBW=1MHz; VBW ≥ 1/T, where T is "Pulse On Time", e.g., LE VBW≥1/625us, VBW=3kHz.
- Note 6: No level of unwanted emissions exceeds the level of the fundamental emission.



Transmitter Radiated Unwanted Emissions

Modulation Mode	LE-1Mbps	Test Freq. (MHz)	2440
Operating Function	Transmit	Polarization	H

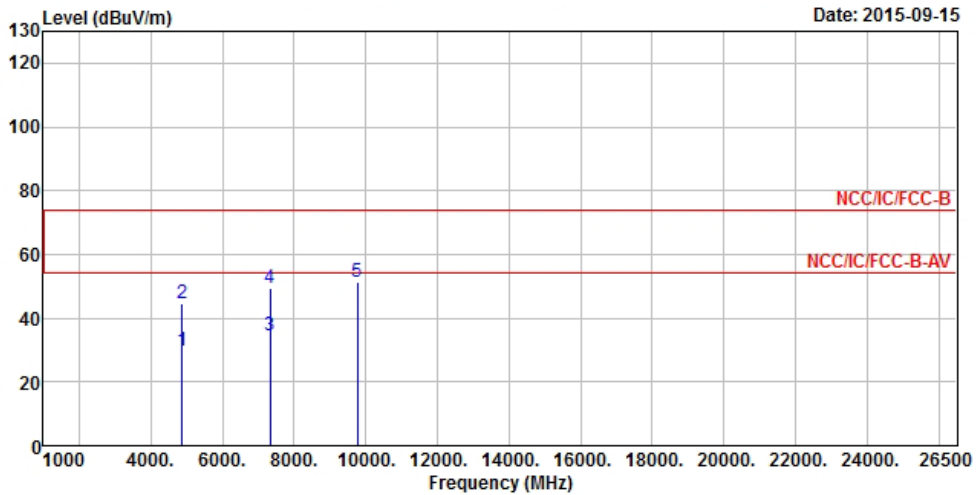

	Freq	Level	Over Limit	Limit Line	ReadAntenna Level	Cable Factor	Preamp Loss	Remark
	MHz	dBuV/m	dB	dBuV/m	dBuV	dB/m	dB	
1	4880.00	29.90	-24.10	54.00	43.16	33.38	5.72	52.36 Average
2	4880.00	44.60	-29.40	74.00	57.86	33.38	5.72	52.36 Peak
3	7320.00	34.51	-19.49	54.00	44.52	36.36	7.14	53.51 Average
4	7320.00	49.32	-24.68	74.00	59.33	36.36	7.14	53.51 Peak
5	9760.00	51.10			59.63	37.55	8.28	54.36 Peak

- Note 1: ">20dB" means spurious emission levels that exceed the level of 20 dB below the applicable limit.
- Note 2: Measurement receive antenna polarization: H (Horizontal), V (Vertical)
- Note 3: For restricted bands, the peak measurement is fully sufficient, as the max field strength as measured with the Peak-Detector meets the AV-Limit so that the AV level does not need to be reported in addition.
- Note 4: For un-restricted bands, unwanted emissions shall be attenuated by at least 20 dB relative to the maximum measured in-band level (99.64 dBuV/m).
- Note 5: Average emission setting: RBW=1MHz; VBW ≥ 1/T, where T is "Pulse On Time", e.g., LE VBW≥1/625us, VBW=3kHz.
- Note 6: No level of unwanted emissions exceeds the level of the fundamental emission.

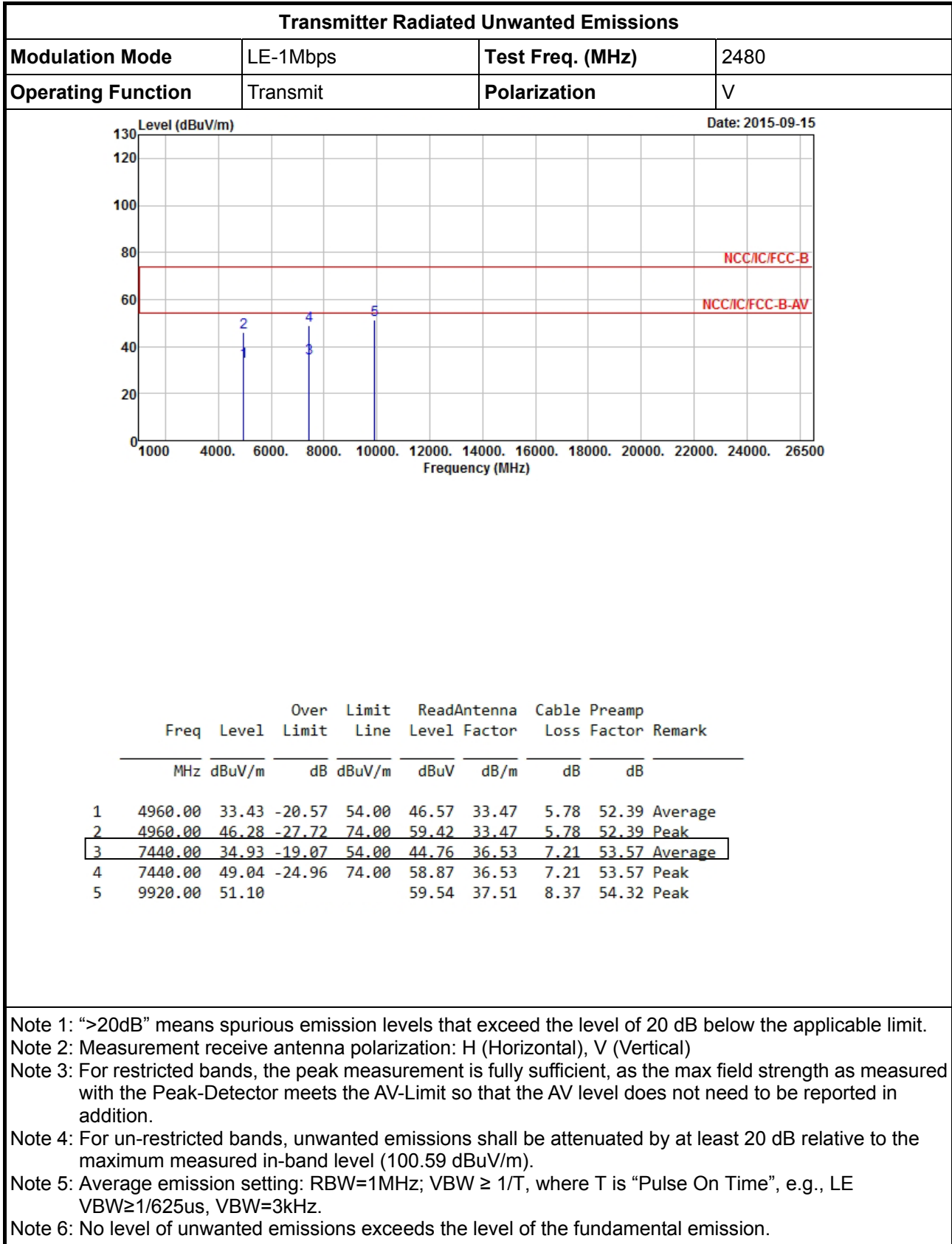



Transmitter Radiated Unwanted Emissions

Modulation Mode	LE-1Mbps	Test Freq. (MHz)	2480
Operating Function	Transmit	Polarization	H

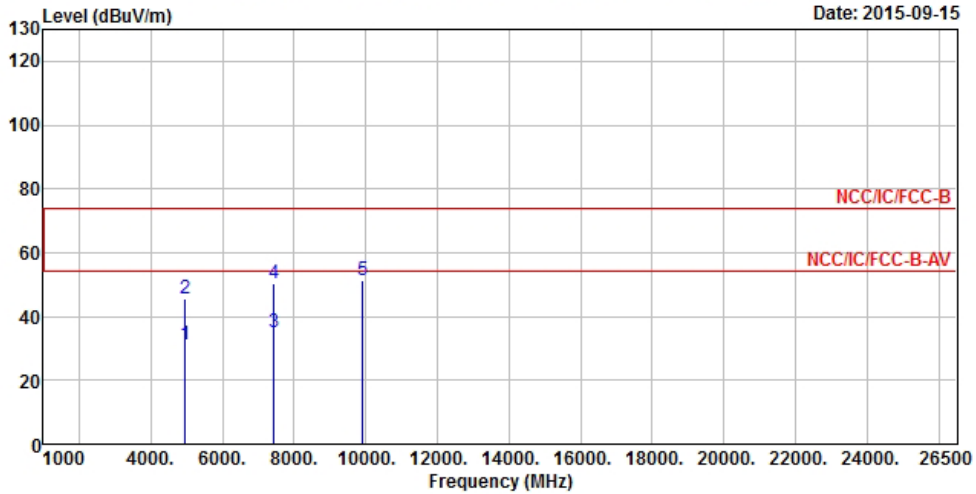

	Freq	Level	Over Limit	Limit Line	ReadAntenna Level	Cable Factor	Preamp Loss	Preamp Factor	Remark
	MHz	dBuV/m	dB	dBuV/m	dBuV	dB/m	dB	dB	
1	4960.00	31.27	-22.73	54.00	44.41	33.47	5.78	52.39	Average
2	4960.00	45.41	-28.59	74.00	58.55	33.47	5.78	52.39	Peak
3	7440.00	34.85	-19.15	54.00	44.68	36.53	7.21	53.57	Average
4	7440.00	50.21	-23.79	74.00	60.04	36.53	7.21	53.57	Peak
5	9920.00	51.48			59.92	37.51	8.37	54.32	Peak

- Note 1: ">20dB" means spurious emission levels that exceed the level of 20 dB below the applicable limit.
- Note 2: Measurement receive antenna polarization: H (Horizontal), V (Vertical)
- Note 3: For restricted bands, the peak measurement is fully sufficient, as the max field strength as measured with the Peak-Detector meets the AV-Limit so that the AV level does not need to be reported in addition.
- Note 4: For un-restricted bands, unwanted emissions shall be attenuated by at least 20 dB relative to the maximum measured in-band level (100.59 dBuV/m).
- Note 5: Average emission setting: RBW=1MHz; VBW ≥ 1/T, where T is "Pulse On Time", e.g., LE VBW≥1/625us, VBW=3kHz.
- Note 6: No level of unwanted emissions exceeds the level of the fundamental emission.



4 Test Equipment and Calibration Data

Instrument	Manufacturer	Model No.	Serial No.	Characteristics	Calibration Date	Remark
EMC Receiver	R&S	ESCS 30	100174	9kHz ~ 2.75GHz	Apr. 15. 2015	AC Conduction
LISN	SCHWARZBECK MESS-ELEKTRONIK	NSLK 8127	8127-477	9kHz ~ 30MHz	Jan. 22, 2015	AC Conduction
RF Cable-CON	HUBER+SUHNER	RG213/U	07611832020001	9kHz ~ 30MHz	Oct. 30, 2015	AC Conduction
EMI Filter	LINDGREN	LRE-2030	2651	< 450 Hz	NCR	AC Conduction

Note: Calibration Interval of instruments listed above is one year.

Instrument	Manufacturer	Model No.	Serial No.	Characteristics	Calibration Date	Remark
Spectrum Analyzer	R&S	FSV 40	101500	9KHz~40GHz	May 06, 2015	RF Conducted
Temp. and Humidity Chamber	Giant Force	GTH-225-20-S	MAB0103-001	-20 ~ 100°C	Jun. 12, 2015	RF Conducted
Signal Generator	R&S	SMR40	100116	10MHz ~ 40GHz	Jul. 28, 2015	RF Conducted
AC Power Source	G.W	APS-9102	EL920581	AC 0V ~ 300V	Jun. 25, 2015	RF Conducted

Note: Calibration Interval of instruments listed above is one year.

Instrument	Manufacturer	Model No.	Serial No.	Characteristics	Calibration Date	Remark
3m Semi Anechoic Chamber	TDK	SAC-3M	03CH09-HY	30MHz ~ 1GHz 3m	Jul. 01, 2015	Radiation
3m Semi Anechoic Chamber	TDK	SAC-3M	03CH09-HY	1GHz ~ 18GHz 3m	Jul. 01, 2015	Radiation
Amplifier	EMC	EMC9135	980232	9kHz ~ 1.0GHz	Jan 27, 2015	Radiation
Amplifier	Agilent	8449B	3008A02373	1GHz ~ 26.5GHz	Sep. 10, 2015	Radiation
Spectrum	KEYSIGHT	N9010A	MY54200885	10Hz ~ 44GHz	Jul. 15, 2015	Radiation
Bilog Antenna	TESEQ	CBL 6112D	35418	30MHz ~ 1GHz	Mar. 30, 2015	Radiation
Horn Antenna	AARONIA AG	POWERLOG 70180	05192	1GHz ~ 18GHz	Jan. 05, 2015	Radiation
Horn Antenna	SCHWARZBECK	BBHA9170	BBHA9170614	18GHz ~ 40GHz	Dec. 29, 2014	Radiation
RF Cable-R03m	Jye Bao	RG142	CB021	9kHz ~ 1GHz	Jul. 23, 2015	Radiation
RF Cable-high	Jye Bao	RG142	03CH09-HY	1GHz ~ 40GHz	Jul. 23, 2015	Radiation
Turn Table	Chain Tek	T-200S	1308028	0 ~ 360 degree	N/A	Radiation
Antenna Mast	Chain Tek	MBS-400	1308049	1 ~ 4 m	N/A	Radiation

Note: Calibration Interval of instruments listed above is one year.

Instrument	Manufacturer	Model No.	Serial No.	Characteristics	Calibration Date	Remark
Amplifier	MITEQ	JS44-18004000-33-8P	1840917	18GHz ~ 40GHz	Jun. 02.2015	Radiation

Note: Calibration Interval of instruments listed above is two years.