

Comba 850MHz MCPA TBS SYSTEM User Manual

The logo for Comba, featuring the word "Comba" in a bold, blue, sans-serif font.

Let **Communication** **Be Available**

May 2009

COPYRIGHT DECLARATIONS

This is an unpublished work the copyright in which vests in Comba Telecom Ltd. ("Comba"). All rights reserved. The information contained herein is confidential and the property of Comba and is supplied without liability for errors or omissions. No part may be reproduced, disclosed or used except as authorised by contract or other written permission. The copyright and the foregoing restriction on reproduction and use extend to all media in which the information may be embodied.

FCC COMPLIANCE

- This device complies with Part 15 of the FCC Rules. Operation is subject to the condition that this device does not cause harmful interference.
- Changes or modifications not expressly approved by the party responsible for compliance could void the user's authority to operate the equipment.
- NOTE: This equipment has been tested and found to comply with the limits for a Class A digital device, pursuant to Part 15 of the FCC Rules. These limits are designed to provide reasonable protection against harmful interference when the equipment is operated in a commercial environment. This equipment generates, uses, and can radiate radio frequency energy and, if not installed and used in accordance with the instruction manual, may cause harmful interference to radio communications. Operation of this equipment in a residential area is likely to cause harmful interference in which case the user will be required to correct the interference at his own expense.
- To comply with FCC RF exposure requirements, the device and the antenna for this device must be installed to ensure a minimum separation distance of 11.9 meters or more from a person's body.
Other operating configurations should be avoided.

ABOUT THIS DOCUMENT

■ Purpose of this document

This document provides training and guide for the installation of Comba MCPA TBS system.

■ Reader of this document

This document will be used and read by operator who will or is going to do Comba MCPA TBS system installation or for people who will or is going to do site service, such as commissioning, maintenance, troubleshooting, etc.

■ Contents of this document

This document consists of system introduction, system installation and system initial startup. In system installation, it includes the site preparation, installation instruction of each module, and all kinds of cable connection.

■ Suggestion for this document

Whilst every endeavor is made to ensure the accuracy of this and all Comba documents, there is always the possibility that an inaccuracy or omission could occur. In order that any amendment/remedial action can be carried out promptly, we would appreciate your co-operation in filling out and returning a photocopy of this customer reply sheet as soon as possible. Please refer to Appendix A.

CONTENTS

Section	Page
COPYRIGHT DECLARATIONS	1-1
COPYRIGHT DECLARATIONS	1-2
FCC COMPLIANCE	1-3
ABOUT THIS DOCUMENT	1-3
CONTENTS 1-3	
ISSUE CONTROL	1-3
ISSUE CONTROL	1-3
0.1 SAFETY LABELLING.....	1-3
0.2 IMPORTANT SAFETY NOTICE	1-3
1 SYSTEM INTRODUCTION.....	1-3
1.1 PURPOSE OF MCPA TBS SYSTEM	1-3
1.2 MODELS COMPLIANCE	1-3
2 SYSTEM INSTALLATION.....	2-3
2.1 GERNERAL INTRODUCTION.....	2-3
2.2 INSTALLATION SITE REQUIREMENT.....	2-3
2.3 POWER SUPPLY REQUIREMENT.....	2-3
2.3.1 UNPACKING AND INSPECTION	2-3
2.3.2 INSTALLATION TOOLS REQUIREMENT.....	2-3
3 SYSTEM POWER ON AND OFF	3-3
3.1 CONTROLS AND INDICATORS	3-3
3.1.1 MCPA CONTROL AND INDICATOR.....	3-3
3.1.2 CONTROL MODULE CONTROL AND INDICATORS	3-3
3.2 SYSTEM DC POWER ON AND OFF PROCEDURES.....	3-3
4 APPENDICES	4-3
4.1 APPENDIX A: SUGGESTION FOR THE DOCUMENT.....	4-3
4.2 APPENDIX B: SERVICE POLICY AND RETURN OF EQUIPMENT	4-3
4.3 APPENDIX C: RMA (RETURN MATERIAL AUTHORIZATION) FORM	4-3

ISSUE CONTROL

Change No.	ENU	Date of Change	Details Of Change
1	0-0-1	March 2009	Initial Draft
2	1-0-0	March 2009	Original Issue.

0.1 SAFETY LABELLING

This document contains safety and note labels in accordance with appropriate standards as following:

- DANGER
- WARNING
- CAUTION

In the interests of conformity with the territory standards for the country concerned, the equivalent territorial admonishments are also shown.

■ DANGER

These draw the attention of personnel to hazards which will cause death or severe injury to the operator or others. Examples of use are cases of high voltage, radiation emission, toxic substances, point of high temperature, etc. The format is as following:



DANGER

Text describing the hazards conditions/damage, and instructions for proper operation

■ WARNING

These draw the attention of personnel to hazards which can cause death or severe injury to the operator or others. The format is as following:



WARNING

Text describing the hazards conditions/damage, and instructions for proper operation

■ CAUTION

These draw attention to hazards which may cause minor personal injury, or cause damage to the equipment where there is a possibility of property loss or seriously impairing its performance. The format is as following:



CAUTION

Text describing the matters where that have possibility of minor injury or property loss or impairing equipment performance, and instruction for proper operation

0.2 IMPORTANT SAFETY NOTICE

Before the installation, please read this section carefully and follow on all detailed safety instructions. A safe and successful installation relies on your careful reading and following.

1. GENERAL SAFETY INSTRUCTIONS



Follow on following instruction can avoid severe injury or critical damage to the equipment:

DANGER

- Before the installation or system operation, review the hazards which could occur during mechanical installation, RF and electricity connections.
- The rack or outdoor cabinet is setup at a flat ground or platform.
- Do not force to install equipment onto the rack or cabinet which can't support its weight.
- Do not do any operation for TBS system when your hands are wet.
- Do not do cleaning for equipment with wet cloth, liquid cleaner, solvent or aerosol cleaner.
- In order to avoid electrical shock, do not recover circuit packs or touch DC terminals without any protection.
- In order to avoid strong radiation, please switch off the RF input from BTS. Before startup TBS system, RF input cables and RF output feeder lines are properly connected to Passive Module.
- Check the voltage and current request and do not connect the wrong voltage power source.
- Check the power cable requirement for right voltage and current.
- Do not do power connection before main breaker is still on.
- Do not expose the equipment to liquid, moisture, or oily or water vapor of any kind, under any conditions.
- Do not put your hands into the running blade of cooling fans.



WARNING

Follow on following instruction can avoid and eliminate the possibility for personal severe injury or damage to equipment:

- Read and review the site preparation and assure good ventilation for heat dissipation.
- Avoid to knock at some hard things and hurt your body, make sure the move direction and sight is clear when move equipment,
- Have enough support or lift capability when do mechanical installation which is beyond one person's ability.
- Check the labels carefully and install the right modules in right system.
- Do not expose the equipment to direct sunlight or a high temperature place.
- Install blank panel for empty slots.
- Do not put hands or other things into empty slots.
- Do not place other things on the top of equipment.

- Do not slam modules into Subrack or rack directly.
- Switch off circuit breaker or disconnect power supply when do operation
- Use profession installation tools to do mechanical installation RF and power connection.
- Check whole equipment is well grounded before startup.



CAUTION

Follow on following instruction can avoid and eliminate the possibility for personal minor injury or damage to equipment :

- Please make sure you have got professional training and you understand the procedures clearly. Otherwise you need professional technician site support.
- Do not start installation when you find the equipment package is damaged, please contact forwarder.
- Do not start installation when you find some components/materials are missing, please contact forwarder.
- Make sure installation tools are all available and properly.
- Do not place any magnet or magnetic static material near to equipment.
- Do not tear the seals on equipment which is still in warranty period.

2. SITE SERVICE REQUEST

When site service request includes the activities as following:

- Equipment need to move
- Alarm or fault can't be solved and need troubleshooting
- Equipment can't work and need troubleshooting
- Water leakage into equipment
- Equipment damage (such as drop or fall)
- Equipment maintenance, such as cleaning, visual inspection, RF and power cable connection checking, etc
- Module replacement

Please contact with field engineer or Comba local office (Appendix B) for site service. Only personnel who have been professionally trained and authorized can provide the service. And please follow on following instructions for site service.



WARNING

- Before operation, please read the general safety instructions and make sure you know the hazards and understand the working procedures.
- Do not remove covers of any circuit pack or modules. Only personnel who have been professionally trained and authorized.
- Do not disassemble modules and cable connections. Only personnel who have been professionally trained and authorized can do it.
- Do not do cleaning for equipment with wet cloth, liquid cleaner, solvent or aerosol cleaner. For dust or dirt accumulation on air vents or filters, use compressed air or a brush with soft bristles to loosen and remove it. And

please take some eye protection when you use compressed air to do cleaning.

- Do not tear the seals on equipment which is still in warranty period.
- When replace fault cooling fans, please make sure the DC power is disconnected for the fan. And do not place hands, wire, screws or other things into the running fans.
- When do troubleshooting, do not disconnect RF cable before the RF signal from BTS is switched off.

Note:

- Inspect the module which is used for replacement. If any damage to the package or connectors, please contact with forwarder.
- For equipment problems, please contact with field engineer or Comba local office for site support.
- Do not return fault equipment before you contact with Comba local office for shipping instruction.
- Do not return fault equipment without suitable package. Try to use original package.

End of section

1 SYSTEM INTRODUCTION

This section includes the following contents:

- Purpose of MCPA TBS System
- Models compliance

In this section, reader can understand the purpose of Comba MCPA TBS system and the definition of different configurations.

1.1 PURPOSE OF MCPA TBS SYSTEM

■ **BTS coverage extension and network optimization**

The system is designed to enhance the downlink output power to a high power and make up for the cable loss between antenna and BTS. Working together with Tower Mounted Amplifier (TMA) at the top of tower which can improve the BTS receiver sensitivity, the whole system can provide more balance both for uplink and downlink budget. So the system can help network optimization and improve network KPI.

■ **CAPEX cutting and flexible for traffic capacity expansion**

With integrated high power MCPA module, wireless operators can combine downlink signals together without worrying about the power loss and coverage are shrinking. This can help wireless operators decrease the investment of feeder lines and antennas dramatically. Meanwhile, our customers can do traffic capacity easily and don't concern the number of carriers, spacing of carriers and the intermodulation interference which is caused in SCPA system.

■ **OPEX cutting and easy for maintenance**

Deploying MCPA technology, it can help decrease the number and the power of active modules in BTS system so that it can improve the MTBF. And compared to the efficiency of using SCPA, the system can improve the overall BTS system efficiency with lower power consumption. The features will help customer cut their operation expense.

1.2 MODELS COMPLIANCE

According to FCC KDB 754507, FCC test of TS-81-1203354A can meet the FCC requirement to cover models TS-81-1203354A, TS-81-1202351A, TS-81-1201351A, TS-81-1203154A.

Configuration 3 - 850 MHz, 4x2, 3 sector
TS-81-1203354A

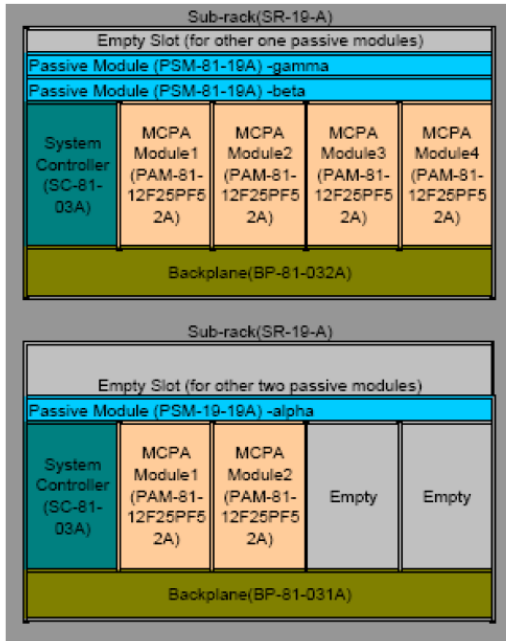

Configuration 1 - 850 MHz, 4in4out, 3 sector
TS-81-1201351A

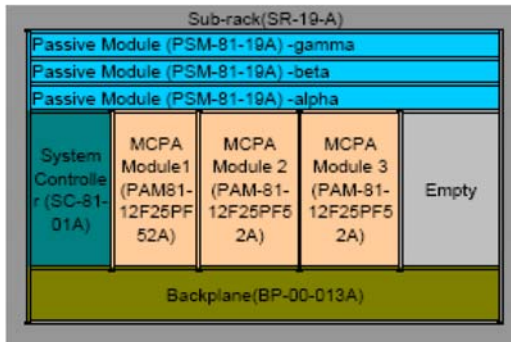

Configuration 2 - 850 MHz, N+1, 3 sector
TS-81-1202351A

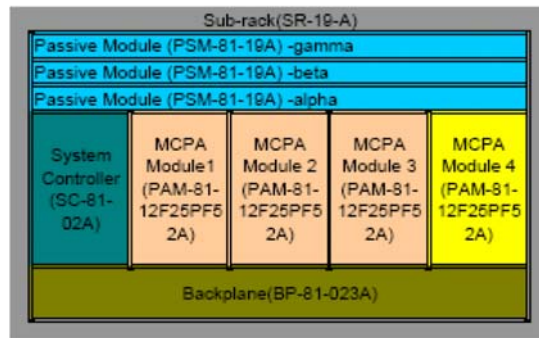

Configuration 5 - 850 MHz, 4x2, 1 sector
TS-81-1203154A

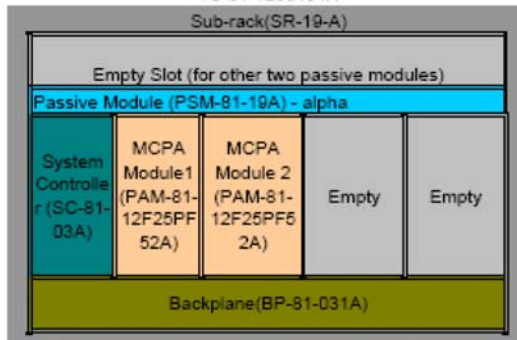

FCC ID TS-81-1202351A (configuration 13,N+1,3 sectors) can cover the 850MHz part of dualband system TS-71-1202351A.

Configuration 13 - 850/1900 MHz, N+1, 3 sector
TS-71-1202351A

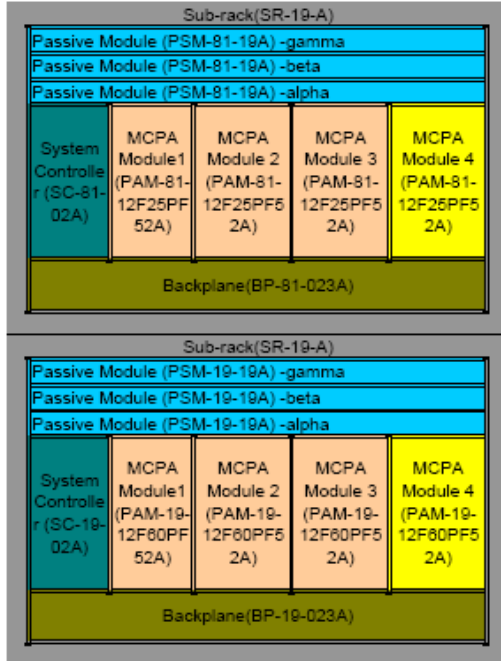

End of section

2 SYSTEM INSTALLATION

2.1 GERNERAL INTRODUCTION

This section introduces the detailed installation procedures of Comba MCPA TBS system. And before installation, pre-site survey, unpacking inspection and tools preparation are also included. In order to eliminate the wrong operation and shorten system installation time, this section and concerned regulation/standard issued by local government should be read carefully.

For installation procedures of each configuration, it will include contents as following:

- Installation Site Requirement
- Power Supply Requirement
- Temperature and Humidity Requirement
- Unpacking and Inspection
- Installation Instruction

2.2 INSTALLATION SITE REQUIREMENT



Do not force to install equipment onto the rack which can't support the weight of TBS system.

DANGER

MCPA TBS system is installed on 19" rack. The following table is mechanical specifications of all configurations:

Table 1: Mechanical Specifications of Configurations

Configuration	Dimensions(HxWxD,inch)	Weight (lbs,approx.)
N+1	26.25x19.00x20.00	251
4 in 4 out	26.25x19.00x20.00	226
4x2, 3 sectors	42.00x19.00x20.00	341
4x2, 1 sector	19.25x19.00x20.00	127
N+1, dualband	52.50x19.00x20.00	505
4x2,dualband	68.25x19.00x20.00	645

Please check the front and rear space of rack to make sure there's enough clearance space for easy cabling and quick installation.

2.3 POWER SUPPLY REQUIREMENT

The power cable selection should rely on the distance between rectifier and Backplane. At the power terminal of Backplane for MCPA and Cooling Fans, a 27+/-1Vdc is needed.



- The AC or DC power source must be connected to dedicated lightning arrestor to avoid damage to TBS system in case of lightning.
- CAUTION** • All modules of TBS system should be well grounded.

2.3.1 UNPACKING AND INSPECTION

TBS system was factory tested, inspected, packed, and delivered to the carrier with utmost care. When the equipment is delivered to installation site, go through the following unpacking and inspection process.

1: Carefully unpack and check each package/container against the packing list. For any shortage, double confirm with carrier. Do not remove items from packing materials until installation.

2: Visually inspect the enclosure, connectors, and cables for damage caused by improper shipment. Try to check whether there is evidence for water leakage, bent or wrapped chassis, loose screws or nuts, or extraneous packing material in the connectors or fans. Inspect male connectors on modules and harnesses for bent connector pins.

- Note:
1. If the equipment is damaged or something is missing, do not accept shipment from carrier until the carrier's agent endorses a statement of the irregularity on the face of the carrier's receipt. Without documentary evidence, a claim cannot be processed.
 2. After confirm with carrier and delivery person, if the equipment needs to be returned to factory, contact with Comba local office (see Appendix B) to get a return authorization and go through RMA process (Refer to Appendix C)

2.3.2 INSTALLATION TOOLS REQUIREMENT

Table 2: Tools and Equipment Requirement

Tools/Equipment	Function	Quantity	Provider
Telecommunication installer kit	Tools necessary for cables installation, voltmeter and safety equipment per installer (such as hard hat and gloves), etc.	As needed	Installer
Wrenches, Screwdrivers	SMA -0.5 to 0.7 N-m wrench N – 1.3 to 1.7 N-m wrench 7/16 DIN- 25 to 30N-m wrench Captive Screws- Philip Screwdriver Hand tools	As needed	Installer

3 SYSTEM POWER ON AND OFF

This section introduces the process of system power on and off process. And the introduction of visual controls and indicators of MCPA and System Controller is used to check whether the mechanical installation is proper.

The contents are as following:

- Controls and Indicators of System Controller and MCPA module
- System power on and off

3.1 CONTROLS AND INDICATORS

Before system initial startup, to understand the controls and indicators is very important for operator. TBS system provides Circuit Breaker and Enable Switch and some LED indicators on the front panel of MCPA Module and System Controller.

3.1.1 MCPA CONTROL AND INDICATOR

On the Front panel of MCPA Module, the controls and LED indicators are showed in following figure. The function is explained in table 1.



Figure 1: Controls and Indicators on Front Panel of MCPA Module

Table 3: Functions of Controls and Indicators on MCPA Module

Control/Indicators	Status	Functions
Circuit Breaker	ON	Provide DC power to MCPA
	OFF	Shut the DC power to MCPA. Before plug out MCPA, the Circuit Breaker should be push to OFF status
Enable Switch	ENABLE	Turn on RF output from MCPA. The Enable LED is in green color
	DISABLE	Turn off RF output power from MCPA, but System Controller can still detect MCPA and feedback the status. Before turn off Circuit Breaker, the switch had better to turn to DISABLE status. The Enable LED is in black color
Power LED	Green	27VDC power supply is normal
	Black (OFF)	27Vdc power supply is not available.
Enable LED	Green	The PA is at ENABLE status
	Black (OFF)	The PA is at DISABLE status
Status LED	Green	MCPA is in normal operation, no alarms
	Amber	MCPA is abnormal and there should be some Minor Alarm

	Red	MCPA is abnormal and there should be some Major alarm
--	-----	-------------------------------------------------------

3.1.2 CONTROL MODULE CONTROL AND INDICATORS

Except the status of MCPA can be visually monitored and controlled, the front panel of System Controller also have LED indicators and interfaces for system diagnosis and commissioning. The front panel is shown as following. The function and purpose are explained in table 3-x.

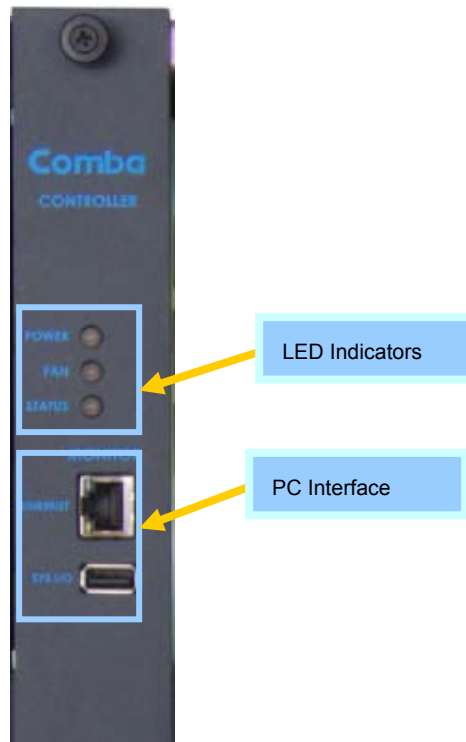

Figure 2: Indicators and Interface on Front Panel of System Controller

Table 4: Functions of Indicators and interfaces of System Controller

Indicators/Interfaces	Status	Functions
POWER LED	Green	+27DC power to the system is normal
	Black (OFF)	+27Vdc power supply is unavailable.
FAN LED	Green	All 6 cooling fans are in normal running.
	Orange	Minor Alarm: Cooling Fan is abnormal.
Status LED	Green	The system is in normal operation, no alarms.
	Orange	The system is abnormal and there should be some minor alarm.
	Red	The system is abnormal and there should be some major alarm.
Ethernet Port		Used for local PC connection for commissioning and monitoring. This port is also reversed to connect to BTS controller for TBS system remote commissioning and monitoring.
USB Port		Factory use

3.2 SYSTEM DC POWER ON AND OFF PROCEDURES

The following procedures are for TBS system DC power on and off.

1. Test the antenna system and ensure the echo loss within working frequency is less than -14dB (VSWR<1.5).



- Do not turn on the power supply from Rectifier.
- Do not turn on input power from BTS.

DANGER

2. Visually inspect the power connection within the equipment. Ensure that the power cable is correctly and securely connected.
3. Check grounding connection and verify that the ground resistance is less than 5Ω.
4. Check all circuit breaker of MCPA modules have been set to OFF. And Enable Switch has been set to DISABLE position.
5. Before turn on MCPA Module, use power meter to test the input composite power from BTS is not more than 43dBm.



WARNING

- Do not input >43dBm power into MCPA.
- Before applying power from BTS, please make sure the MCPA has been properly terminated at 50 ohms.

6. Turn on the power from Rectifier and verify the input voltage for MCPA is in the range of 26-28Vdc on the power terminals at the back of Backplane. After power on, the cooling fans will run and LED indicators on System Controller front panel will become stable without red or amber color.
7. Turn on power of MCPA one by one (set Circuit Breaker to ON and push Enable Switch to ENABLE). Check the LED indicators and there's not red or amber color.

Note: After this step, all LED indicator status on the front panel of System Controller and MCPA modules are in normal color (refer to table 21 & 22). If there are any alarms, please contact with field engineer.

8. Push Enable Switch to DISABLE and push Circuit Breaker to OFF. Turn off power supply to MCPA and rectifier. Write down installation record and check with field engineer for system commissioning.

Note: After this step 7, if the system needs to be put into service, please go to 'Comba MCPA TBS system operation and maintenance manual' Section 2& 3.

End of section

4 APPENDICES

4.1 APPENDIX A: SUGGESTION FOR THE DOCUMENT

Customer Information:

Name	
Title	
Company	
Date	
Address	
Telephone Number	

Customer Comments:

Equipment title	
ENU	
Page number	
Paragraph number	
Line number	
Figure number	
Details of inaccuracies	
Other comments	

Contact points:

E-mail: document@Comba-telecom.com

FAX: +852-21166055

4.2 APPENDIX B: SERVICE POLICY AND RETURN OF EQUIPMENT

The repair of individual units and modules of this equipment is not considered practicable without factory facilities. It is, therefore, the policy of Comba whereby faulty units or modules are returned to the local agent for repair. To enable an efficient, prompt after sales service to be provided for the diagnosis, repair and return of any faulty equipment, please comply with the following requirements.

Items to be sent for repair should be packaged so as to provide both electrostatic and physical protection and a Repair Material Authorization (RMA) should be completed giving the required information. A sample RMA form is provided in Appendix C.

This request must be included with the item for repair, items for repair should be sent to the nearest Comba office:

COMBA TELECOM LTD.

USA Office

Address: 2390 Bering Drive, San Jose, CA 95131, USA

Tel: +1 408 526 0180

Fax: +1 408 526 0181

Email: combausa@comba-telecom.com

Hong Kong Office

Address: 611 East Wing, No. 8 Science Park West Avenue, Hong Kong Science Park,
Tai Po, Hong Kong.

Tel: +852 2636 6861

Fax: +852 2637 0966

Email: combahk@comba-telecom.com

Singapore Office

Address: 865 Mountbatten Road, Katong SC #05-43, Singapore 437844

Tel: + 65 6345 4908

Fax: + 65 6345 1186

Email: combasg@comba-telecom.com

Thailand Office

Address: 3rd Floor, T. Shinawatra Building, 94 Sukhumvit Soi 23, Sukhumvit Road,
Klongtoeynua, Wattana, Bangkok 10110

Tel: +66 2664 3440

Fax: +66 2664 3442

India Office

Address: Suite No. 2, E-172, TSH House, Greater Kailash – I, New Delhi – 110 048, India

Tel: + 91 11 5173 9997 / 8

Fax: + 91 11 5173 9996

Email: comba@comba-telecom.com

Sweden Office

Address: Gustavslundsvagen 147, S- 167 51 Bromma, Stockholm, Sweden

Tel: +46 8 25 38 70

Fax: +46 8 25 38 71

Email: info@comba-telecom.se

Brazil Sales Office

Avenida Engenheiro Luiz Carlos Berrini 1297, cj 122, sala 03 04571-090 São Paulo, Brazil

Tel: +55 11 55050549

Fax: +55 11 55050549 ext 7

China Office

Address: No.10, Shenzhou Road, Guangzhou Science City, Guangzhou, China

Tel: + 86 20 2839 0000

Fax: + 86 20 2839 0136

Email: combagz@comba-telecom.com

4.3 APPENDIX C: RMA (RETURN MATERIAL AUTHORIZATION) FORM



Comba Telecom Ltd.
 611 East Wing, No. 8 Science Park West Avenue, Hong Kong Science Park, Tai Po, Hong Kong
 Tel: +852 2636 6861 Fax: +852 2637 0966

RMA Request Form

Date: _____

From: _____
 Address: _____
 Tel: _____ Fax: _____
 E-Mail: _____
 ATTN: _____

Product Information:

Item	Model	Serial Number	Return Category	Qty	Problem Description
1					
2					
3					
4					
5					
6					
7					
8					
9					
10					

Notes:

1. For 'Return Category' column, please select from **A:** Return of Defective Product, **B:** Return of Trial Sample, or **C:** Return of New and Unused Product.
2. If **A** or **C** category of return product is chosen, please give short description of the problem or reason for returning.

Transportation Information:

Location of Product: _____

Transportation Method: _____

Shipping Forwarder: _____

Note: Location of Product* must be stated, while 'Transportation Method' or 'Shipping Forwarder' can be left blank if not determined.

Signature: _____

For Comba Use (Only)

Return Merchandise Authorization Number (RMA#): _____

Recommended Action: _____

Shipment and Handling Cost to be paid by: _____

Approved by: _____

Date: _____

End of section

End of Document