



198 Kezhu Road, Sciencetech Park, Guangzhou Economic &
Technology Development District, Guangzhou, China 510663
Tel: +86 20 82155555 Fax: +86 20 82075059
Email: sgs_internet_operations@sgs.com
FEDERAL COMMUNICATIONS COMMISSION
Registration number: 282399

Report No.: GLEMO09060172301
Page: 1 of 113
FCC ID: PX8TS-71-12XXXXXX

TEST REPORT

Application No.:	GLEMO090601723RF
Applicant:	Comba telecom limited
FCC ID:	PX8TS-71-12XXXXXX
Frequency Band:	869MHz to 894MHz, 1930MHz to 1990MHz
Equipment under Test (EUT)	
Name:	850/1900MHz Dual-band Tower Bottom System
Model No.:	TS-71-1203154A, TS-71-1203354A ♣
♣	Please refer to section 3 of this report which indicates which item was actually tested and which were electrically identical.
Standards:	FCC part 22H , FCC part 24E, FCC part 15B
Date of Issue:	July 30, 2009
Test Result :	PASS *

* In the configuration tested, the EUT detailed in this report complied with the standards specified above. Please refer to section 3 of this report for further details.

Authorized Signature:

Stephen Guo
Lab Manager

The manufacturer should ensure that all products in series production are in conformity with the product sample detailed in this report. If the product in this report is used in any configuration other than that detailed in the report, the manufacturer must ensure the new system complies with all relevant standards.

The report must not be used by the client to claim product certification, approval, or endorsement by NVLAP, NIST, or any agency of the federal government. All test results in this report can be traceable to National or International Standards.

This document is issued by the Company subject to its General Conditions of Service printed overleaf, available on request or accessible at www.sgs.com/terms_and_conditions.htm and, for electronic format documents, subject to Terms and Conditions for Electronic Documents at www.sgs.com/terms_e-document.htm. Attention is drawn to the limitation of liability, indemnification and jurisdiction issues defined therein. Any holder of this document is advised that information contained hereon reflects the Company's findings at the time of its intervention only and within the limits of Client's instructions, if any. The Company's sole responsibility is to its Client and this document does not exonerate parties to a transaction from exercising all their rights and obligations under the transaction documents. This document cannot be reproduced except in full, without prior written approval of the Company. Any unauthorized alteration, forgery or falsification of the content or appearance of this document is unlawful and offenders may be prosecuted to the fullest extent of the law. Unless otherwise stated the results shown in this test report refer only to the sample(s) tested and such sample(s) are retained for 90 days only

SGS-CSTC Standards Technical Services Co., Ltd.

Report No.: GLEMO09060172301

Page: 2 of 113

FCC ID: PX8TS-71-12XXXXXX

2 Version

Version No.	Date	Description
00	July 03, 2009	Original
01	July 16,2009	Modify
02	July 30,2009	Add FCC part 15 data

Prepared By: Jeffrey Chen **Date** 2009-7-30

Project Engineer

Check By: Gavin Wu **Date** 2009-7-30

Reviewer

3 Test Summary

Test Item	Test Requirement	Test Method	Result
Output Power	FCC part 22.913 FCC part 24.232	FCC part 2.1046 2-11-04/EAB/RF	PASS
Conducted Spurious Emissions	FCC part 22.917 FCC part 24.238	FCC part 2.1051 2-11-04/EAB/RF	PASS
Band Edge& Intermodulation	FCC part 22.917 FCC part 24.238	FCC part 2.1051 2-11-04/EAB/RF	PASS
Radiated Spurious Emissions	FCC part 22.917 FCC part 24.238	FCC part 2.1053 2-11-04/EAB/RF	PASS
Occupied Bandwidth	2-11-04/EAB/RF	FCC part 2.1049 2-11-04/EAB/RF	PASS
Out of Band Rejection	2-11-04/EAB/RF	2-11-04/EAB/RF	PASS
Frequency Stability	FCC part 22.355 FCC part 24.235	FCC part 2.1055	PASS
Radiated Emission (30MHz to 10GHz)	FCC PART 15, SUBPART B: 2008	ANSI C63.4:2003	PASS

Remark:

Tx: In this whole report Tx (or tx) means Transmitter.

Rx: In this whole report Rx (or rx) means Receiver.

♣ Model No: TS-71-1203154A, TS-71-1203354A

The equipment configuration as below

Model No: TS-71-1203154A

Configuration 15 - 850/1900 MHz, 4x2, 1 sector
TS-71-1203154A

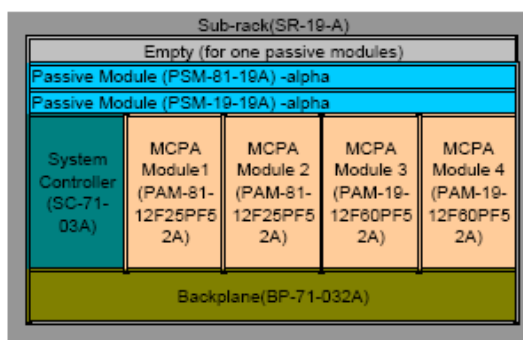

SGS-CSTC Standards Technical Services Co., Ltd.

Report No.: GLEMO09060172301

Page: 4 of 113

FCC ID: PX8TS-71-12XXXXXX

Configuration 14 - 850/1900 MHz, 4x2, 3 sector
TS-71-1203354A

Model No: TS-71-1203354A

Difference between TS-71-

1203154A is:

1. TS-71-1203354A is just 3 TS-71-1203154A stacked into one rack physically.
2. TS-71-1203354A can be used for 3 sectors.

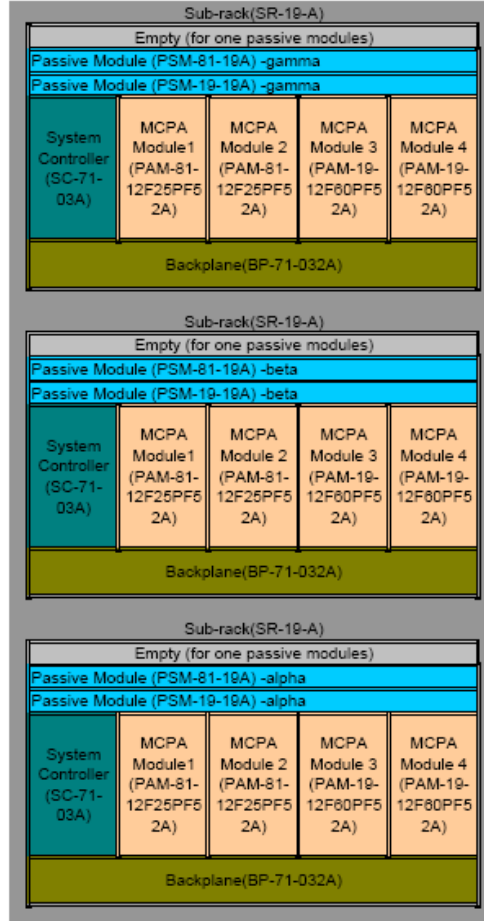

SGS-CSTC Standards Technical Services Co., Ltd.

Report No.: GLEMO09060172301

Page: 5 of 113

FCC ID: PX8TS-71-12XXXXXX

4 Contents

	Page
1 COVER PAGE.....	1
2 VERSION.....	2
3 TEST SUMMARY.....	3
4 CONTENTS.....	5
5 GENERAL INFORMATION.....	6
5.1 CLIENT INFORMATION.....	6
5.2 GENERAL DESCRIPTION OF E.U.T.....	6
5.3 DESCRIPTION OF EUT OPERATION.....	6
5.4 STANDARDS APPLICABLE FOR TESTING.....	6
5.5 TEST LOCATION.....	6
5.6 OTHER INFORMATION REQUESTED BY THE CUSTOMER.....	7
5.7 TEST FACILITY.....	7
6 EQUIPMENTS USED DURING TEST.....	8
7 TEST RESULT.....	10
7.1 E.U.T. OPERATION.....	10
7.2 TEST PROCEDURE & MEASUREMENT DATA.....	12
7.2.1 RF Output Power.....	13
7.2.2 Conducted Spurious Emissions.....	16
7.2.3 Band Edge& Intermodulation.....	48
7.2.4 Radiated Spurious Emissions.....	72
7.2.5 Occupied Bandwidth.....	77
7.2.6 Out of Band Rejection.....	108
7.2.7 Frequency Stability.....	110
7.2.8 Radiated Emissions, 30MHz to 10GHz.....	111-113

5 General Information

5.1 Client Information

Applicant Name: Comba telecom limited
Applicant Address: 611 East Wing, No. 8 Science Park West Avenue, Hong Kong Science Park, Tai Po, Hong Kong

5.2 General Description of E.U.T.

Name: 850/1900MHz Dual-band Tower Bottom System
Model No.: TS-71-1203154A(4x2 3 sector), TS-71-1203354A(4x2 1 sector)
Power Supply: 27V DC
Adaptor: N/A

5.3 Description of EUT operation

Type of Modulation TDMA,GSM,EDGE,CDMA,WCDMA
Emission Designator: DXW(TDMA),F9W(CDMA),
GXW (GSM),GXW (EDGE),GXW (WCDMA)
Cellular Band
Frequency Band: (869MHz to 894MHz downlink)
PCS Band
(1930MHz to 1990MHz downlink)
Norminal Power Gain: 54dBm
Antenna Type N/A

5.4 Standards Applicable for Testing

The standard used was FCC part 2 & FCC part 22 & FCC part 24 & FCC part 15B.

5.5 Test Location

All tests were performed at:

SGS-CSTC Standards Technical Services Co., Ltd., Guangzhou EMC Laboratory,
198 Kezhu Road, Sciencetech Park, Guangzhou Economic & Technology Development District,
Guangzhou, Guangdong, China 510663

Tel: +86 20 82155555 Fax: +86 20 82075059

No tests were sub-contracted.

SGS-CSTC Standards Technical Services Co., Ltd.

Report No.: GLEMO09060172301

Page: 7 of 113

FCC ID: PX8TS-71-12XXXXXX

5.6 Other Information Requested by the Customer

None.

5.7 Test Facility

The test facility is recognized, certified, or accredited by the following organizations:

- **NVLAP – Lab Code: 200611-0**

SGS-CSTC Standards Technical Services Co., Ltd., Guangzhou EMC Laboratory is recognized under the National Voluntary Laboratory Accreditation Program (NVLAP/NIST). NVLAP Code: 200611-0.

- **FCC – Registration No.: 282399**

SGS-CSTC Standards Technical Services Co., Ltd., EMC Laboratory has been registered and fully described in a report filed with the (FCC) Federal Communications Commission. The acceptance letter from the FCC is maintained in our files. Registration 282399, May 31, 2002. With the above and NVLAP's accreditation, SGS-CSTC is an authorized test laboratory for the DoC process.

SGS-CSTC Standards Technical Services Co., Ltd.

Report No.: GLEMO09060172301

Page: 8 of 113

FCC ID: PX8TS-71-12XXXXXX

6 Equipments Used during Test

RE in Chamber						
No:	Test Equipment	Manufacturer	Model No.	Serial No.	Cal. Date (dd-mm-yy)	Cal.Due date (dd-mm-yy)
EMC0525	Compact Semi-Anechoic Chamber	ChangZhou ZhongYu	N/A	N/A	N/A	N/A
EMC0522	EMI Test Receiver	Rohde & Schwarz	ESIB26	100249	28-01-2008	28-01-2009
N/A	EMI Test Software	Audix	E3	N/A	N/A	N/A
EMC0514	Coaxial cable	SGS	N/A	N/A	04-12-2007	04-12-2008
EMC0524	Bi-log Type Antenna	Schaffner -Chase	CBL6112B	2966	12-08-2008	12-08-2009
EMC0519	Bilog Type Antenna	Schaffner -Chase	CBL6143	5070	12-08-2008	12-08-2009
EMC0517	Horn Antenna	Rohde & Schwarz	HF906	100095	12-08-2008	12-08-2009
EMC0040	Spectrum Analyzer	Rohde & Schwarz	FSP30	100324	05-12-2008	05-12-2009
EMC0520	0.1-1300 MHz Pre-Amplifier	HP	8447D OPT 010	2944A06252	11-03-2008	11-03-2009
EMC0521	1-26.5 GHz Pre-Amplifier	Agilent	8449B	3008A01649	11-03-2008	11-03-2009
EMC0075	310N Amplifier	Sonama	310N	272683	10-09-2008	10-09-2009
EMC0523	Active Loop Antenna	EMCO	6502	00042963	09-08-2008	09-08-2010
EMC0530	10m Semi-Anechoic Chamber	ETS	N/A	N/A	10-08-2008	10-08-2009

Conducted Emission						
No:	Test Equipment	Manufacturer	Model No.	Serial No.	Cal. Date (dd-mm-yy)	Cal.Due date (dd-mm-yy)
EMC0306	Shielding Room	Zhong Yu	8 x 3 x 3.8 m ³	N/A	N/A	N/A
EMC0102	LISN	Schaffner Chase	MNZ050D/1	1421	14-12-2008	14-12-2009
EMC0118	Two-line v-netwok	Rohde & Schwarz	ENV216	3560.6550.02	18-07-2009	18-07-2010
EMC0506	EMI Test Receiver	Rohde & Schwarz	ESCS30	100085	14-12-2008	14-12-2009
EMC0107	Coaxial Cable	SGS	2m	N/A	26-11-2008	26-11-2009
EMC0106	Voltage Probe	SGS	N/A	N/A	N/A	N/A
EMC0120	8 Line ISN	Fischer Custom Communications Inc.	FCC-TLISN-T8-02	20550	21-02-2009	21-02-2010
EMC0121	4 Line ISN	Fischer Custom Communications Inc.	FCC-TLISN-T4-02	20549	21-02-2009	21-02-2010
EMC0122	2 Line ISN	Fischer Custom Communications Inc.	FCC-TLISN-T2-02	20548	21-02-2009	21-02-2010

General used equipment						
No:	Test Equipment	Manufacturer	Model No.	Serial No.	Cal. Date (dd-mm-yy)	Cal.Due date (dd-mm-yy)
EMC0006	DMM	Fluke	73	70681569	23-12-2008	23-12-2009
EMC0007	DMM	Fluke	73	70671122	23-12-2008	23-12-2009

SGS-CSTC Standards Technical Services Co., Ltd.

Report No.: GLEMO09060172301

Page: 9 of 113

FCC ID: PX8TS-71-12XXXXXX

Other equipment						
No:	Test Equipment	Manufacturer	Model No.	Serial No.	Cal. Date (dd-mm-yy)	Cal. Due Date (dd-mm-yy)
NA	Power Meter	Agilent	E4419B	MY45100856	2009.6.12	2010.6.11
NA	Signal Generator	Agilent	E4437B	US39260800	2009.6.17	2010.6.16
NA	Signal Generator	Agilent	E4438C	US39260800	2009.6.14	2010.6.14
NA	Spectrum Analyzer	Agilent	N9020A	MY48011385	2008.7.31	2009.7.30
NA	Signal Generator	Rohde&Schwarz	SMU 200A	103303	2009.6.10	2010.6.09

Amplifier driver						
No:	Name.	Manufacturer.	Model No.	Serial No.	Cal. Date (dd-mm-yy)	Cal. Due Date (dd-mm-yy)
NA	Comba MCPA 850MHz	Comba telecom	PA-850	S/N:0905001	/	/
NA	Comba MCPA 1900MHz	Comba telecom	PA-1900	S/N:0905025	/	/

7 Test Result

7.1 E.U.T. Operation

Input voltage:	27V DC
Operating Environment:	
Temperature:	22°C ~26°C
Humidity:	46%~56% RH
Atmospheric Pressure:	990~1005mbar
Test Requirement:	

FIBER-OPTIC AND OTHER SIMILAR RF DISTRIBUTION SYSTEMS

Fiber-optic distribution systems are a type of in-building radiation system that receives RF signals from an antenna, distributes the signal over fiber-optic cable, and then retransmits at another location for example within a building or tunnel. Most fiber-optic systems are signal boosters; however, some may be repeaters. These systems generally have two enclosures typically called host (or local or donor unit) and remote. Some systems may also have an optional expander box for fan-out to multiple remotes. The system transmits downlink signals from the remote unit to handsets, portables, or clients, and transmits uplink signals via from the host unit. Usually but not always the uplink goes through an intermediate amplifier to a "donor" antenna. Therefore both uplink and downlink must be tested, unless filing effectively documents how connection of uplink to donor antenna with or without an intermediate amplifier will be prevented, such as for always only a cabled connection to a base station. Fiber-optic systems are not amplifiers (AMP equipment class) – they are equipment class TNB or PCB. The same approval procedures also apply for multiple-enclosure systems connected by coax cable.

Synonyms and related terms: in-building radiation system, coverage enhancer, distributed antenna system, fiber-optic distribution system, converter, donor anten

Typical in-building or distributed antenna systems can consist of five different components (enclosures), not counting antennas:

1) **host unit**

- a) transmits uplink to base station via antenna thru coax, **passive interface unit** , or **active interface unit** (amplifier)
- b) sends base-station downlink via fiber-optic or coax to **remote**
- c) receives handset uplink via fiber-optic or coax from **remote**
- d) optional connection to **expansion unit** via fiber-optic
- e) separate FCC ID from **remote**, unless electrically identical
- f) **non-transmitting host unit**
- i) connects directly to a base station via coax cable but does not connect to antenna or amplifier
- ii) Part 15 digital device subject to Verification, no FCC ID

2) **remote unit**

- a) receives base-station downlink via fiber-optic or coax from **host**, transmits via antenna to handsets
- b) returns handset uplink via fiber-optic or coax to **host**
- c) separate FCC ID from **remote**, unless electrically identical

3) expansion unit

- a) fiber-optic or coax from **host**
- b) fiber-optic or coax fan-out to **remote(s)**
- c) Part 15 digital device subject to Verification, no FCC ID

4) passive interface unit

- a) contains attenuators, splitters, combiners
- b) coax cable connection between **host** and base-station
- c) passive device, no FCC ID

5) active interface unit

- a) amplifies uplink signal from **host unit** for transmit by donor antenna
- b) attenuates downlink from donor antenna
- c) coax cable connection between **host** and **active interface unit**
- d) usually has separate FCC ID; in some cases could be combined/included with **host** as one enclosure

GENERAL DEFINITIONS FOR CERTIFICATION PURPOSES

The following three general definitions follow from those stated in the Part 22, 24, and 90 rule sections as listed above. Two of the definitions replace previous EAB internal definitions given for booster, repeater and extender. The general term "extender" is the same as booster, but booster should be used rather than extender. The general term "translator" is the same as repeater, but repeater should be used rather than translator.

External radio frequency power amplifier (ERFPA) - any device which, (1) when used in conjunction with a radio transmitter signal source, is capable of amplification of that signal, and (2) is not an integral part of a radio transmitter as manufactured. The EAS equipment class AMP is used only for an ERFPA device inserted between a transmitter (TNB/PCB) and an antenna (has only one antenna port)

Booster is a device that automatically reradiates signals from base transmitters without channel translation, for the purpose of improving the reliability of existing service by increasing the signal strength in dead spots. An "in-building radiation system" is a signal booster. These devices are not intended to extend the size of coverage from the originating base station. A booster can be either single or multiple channels.

Repeater is a device that retransmits the signals of other stations. Repeaters are different from boosters in that they can include frequency translation and can extend coverage beyond the design of the original base station. A repeater is typically single channel but can also be multiple channels.

ERFPA (AMP) and boosters/repeaters (TNB/PCB) can generally be authorized for all rule parts except 15 and 18.

Tests should be done with each typical signal. e.g., for F3E emissions use 2500 Hz with 2.5 or 5 kHz deviation. Use of CW signal for some tests is acceptable in lieu of actual emission, in some cases when CW signal gives worst case.

The EUT belongs to AMP class.

7.2 Test Procedure & Measurement Data

Test Modulation and Frequency
Celluar Band

Modulation	Lowest frequency	Middle frequency	Highest frequency
TDMA	869.60	881.50	893.40
EDGE	869.60	881.50	893.40
GSM	869.60	881.50	893.40
CDMA	871.0	881.50	892.0
WCDMA	872.0	881.50	891.0

PCS Band

Modulation	Lowest frequency	Middle frequency	Highest frequency
TDMA	1931.0	1960.0	1989.0
EDGE	1931.0	1960.0	1989.0
GSM	1931.0	1960.0	1989.0
CDMA	1932.0	1960.0	1988.0
WCDMA	1933.0	1960.0	1987.0

General Test Setup:

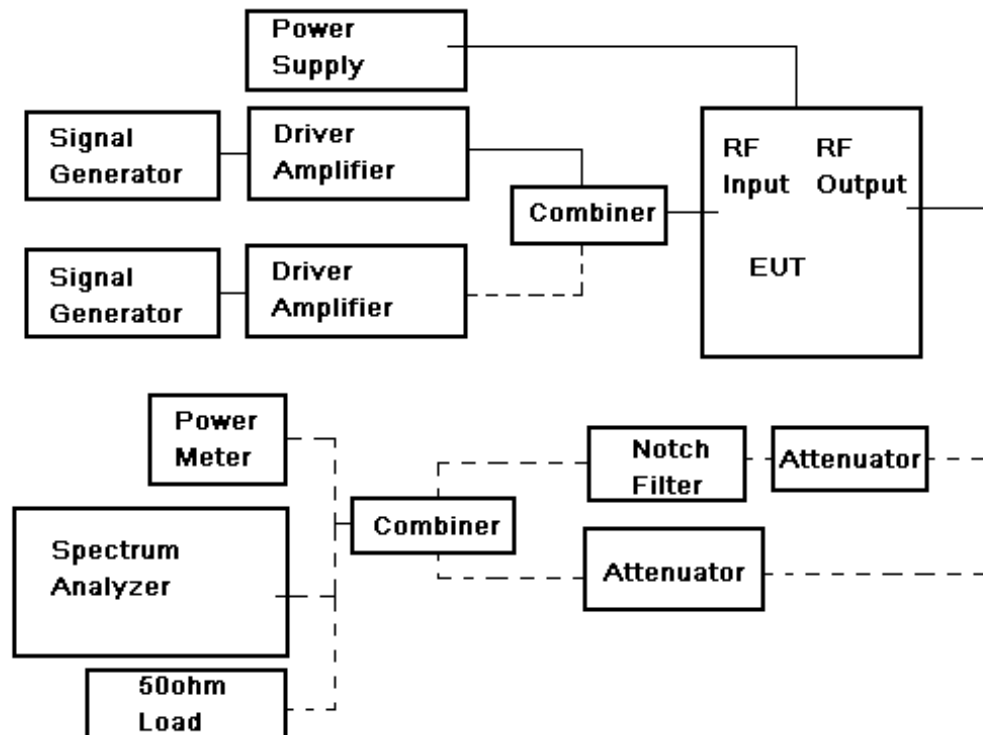

SGS-CSTC Standards Technical Services Co., Ltd.

Report No.: GLEMO09060172301

Page: 13 of 113

FCC ID: PX8TS-71-12XXXXXX

7.2.1 RF Output Power

Test Date: 17 to 19 June 2009

Test Requirement: FCC part 22.913(a) & FCC part 24.232(a)&(b)

22.913(a):Maximum ERP. In general, the effective radiated power (ERP) of base transmitters and cellular repeaters must not exceed 500 Watts.

24.232(a) Base stations are limited to 1640 watts peak equivalent isotropically radiated power (EIRP) with an antenna height up to 300 meters HAAT, except as described in paragraph (b) below. See §24.53 for HAAT calculation method. Base station antenna heights may exceed 300 meters with a corresponding reduction in power; see Table 1 of this section. The service area boundary limit and microwave protection criteria specified in §§24.236 and 24.237 apply.

Table 1—Reduced Power for Base Station Antenna Heights Over 300 Meters

HAAT in meters	Maximum EIRP watts
≤ 300	1640
≤ 500	1070
≤ 1000	490
≤ 1500	270
≤ 2000	160

24.232(b) Base stations that are located in counties with population densities of 100 persons or fewer per square mile, based upon the most recently available population statistics from the Bureau of the Census, are limited to 3280 watts peak equivalent isotropically radiated power (EIRP) with an antenna height up to 300 meters HAAT; See §24.53 for HAAT calculation method. Base station antenna heights may exceed 300 meters with a corresponding reduction in power; see Table 2 of this section. The service area boundary limit and microwave protection criteria specified in §§24.236 and 24.237 apply. Operation under this paragraph must be coordinated in advance with all PCS licensees within 120 kilometers (75 miles) of the base station and is limited to base stations located more than 120 kilometers (75 miles) from the Canadian border and more than 75 kilometers (45 miles) from the Mexican border.

Table 2—Reduced Power for Base Station Antenna Heights Over 300 Meters

HAAT in meters	Maximum EIRP watts
≤ 300	3280
≤ 500	2140
≤ 1000	980
≤ 1500	540
≤ 2000	320

Test Method: FCC part 2.1046

EUT Operation:

Status: The output power of EUT be set to maximum value.

Conditions: Normal conditions

Application: Cellular Band RF output ports, PCS Band RF output ports

Test Configuration:

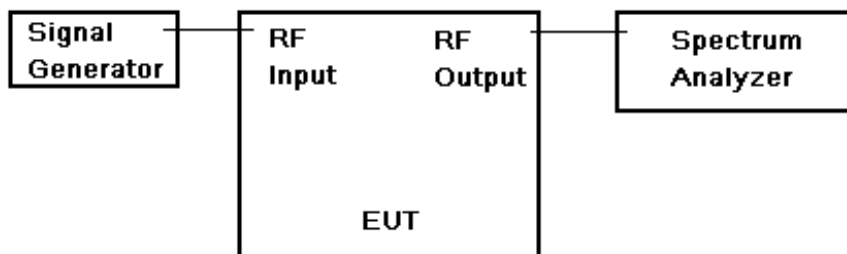

Fig.1 RF Output Power test configuration

Test Procedure:

RF out put power test procedure:

1.
 - a) Connect the equipment as illustrated, when the output power is over the max value of the Spectrum Analyzer, add the attenuator to avoid destroying the facility.
 - b) Set the center frequency of the spectrum analyzer to the assigned transmitter frequency, key the transmitter, and set the level of the carrier to the full scale reference line.
 - c) do not apply any tone to modulate the EUT.
 - d1) Adjust the spectrum analyzer for the following settings:
 - 1) Resolution Bandwidth >> the carrier bandwidth,
 - 2) Video Bandwidth refer to standard requirement.
 - d2) Use spectrum analyzer channel power measurement function;
 - e) Record the frequencies and levels of carrier power;
 - f) Calculate the signal link way loss and final power value.
- Or 2.
 - a) Connect the equipment as illustrated;
 - b) Read the value from the power meter;
 - c) Calculate the signal link way loss and final power value.

Remark:

Output power –

. Power on Form 731 should be clearly understood as either composite of multichannels or per carrier. If power is composite include in comments field: "Power output listed is composite for multi-channel operation."

. Check that the input drive level is at maximum input rating and maximum gain settings for all tests. Check both uplink and downlink input levels. See manual or

brochures/technical description for maximum rating. May need to check FCC identifier of transmitter used for tests.

. Confirm device can not operate in saturation. Are there means to control maximum power and to assure linear operation (use in system configuration may be necessary)? How is saturation or over-modulation prevented for pulsed signal inputs?

SGS-CSTC Standards Technical Services Co., Ltd.

Report No.: GLEMO09060172301

Page: 15 of 113

FCC ID: PX8TS-71-12XXXXXX

7.2.1.1 Measurement Record:

Per channel Power, Input=33dBm					
	TDMA	GSM	EDGE	CDMA	WCDMA
Frequency Band(869MHz ~ 894MHz),Measure Max Out put power(dBm)					
Lowest Frequency	54.0	54.0	54.0	54.0	54.0
Middle Frequency	54.0	54.0	54.0	54.0	54.0
Highest Frequency	54.0	54.0	54.0	54.0	54.0
Max value in W					
Cellular Band	251	251	251	251	251

Per channel Power, Input=33dBm					
	TDMA	GSM	EDGE	CDMA	WCDMA
Frequency Band(1930MHz ~ 1990MHz),Measure Max Out put power(dBm)					
Lowest Frequency	54.0	54.0	54.0	54.0	54.0
Middle Frequency	54.0	54.0	54.0	54.0	54.0
Highest Frequency	54.0	54.0	54.0	54.0	54.0
Max value in W					
Cellular Band	251	251	251	251	251

Remark: test in single channel status, output power is test in full amplifying status.

For the EUT power output can adjust by the software, so all the power output status is being nominal power output status, the adjust procedure refer to the docomument " tune up procedure".

Note: Conducted output power tested. ERP was not tested because the amplifier does not come with an antenna.

The manufacture under test (EUT) is a booster amplifier assembly. The manufacture does not provide an antenna for sale with this product. The end user of this product is to exercise proper engineering judgement to select the appropriate antenna to comply with the EIRP limitation set forth by FCC.

7.2.2 Conducted Spurious Emissions

Test Date: 17 to 19 June 2009

Test Requirement: FCC part 22.917(a) & FCC part 24.238(a)

§22.917 Emission limitations for cellular equipment.

22.917(a) Out of band emissions. The power of any emission outside of the authorized operating frequency ranges must be attenuated below the transmitting power (P) by a factor of at least $43 + 10 \log(P)$ dB.

§24.238 Emission limitations for Broadband PCS equipment

24.238(a) Out of band emissions. The power of any emission outside of the authorized operating frequency ranges must be attenuated below the transmitting power (P) by a factor of at least $43 + 10 \log(P)$ dB.

Test Method: FCC part 2.1051

EUT Operation:

Status: The output power of EUT be set to maximum value

Conditions: Normal conditions

Application: Cellular Band RF output ports, PCS Band RF output ports

Test Configuration:

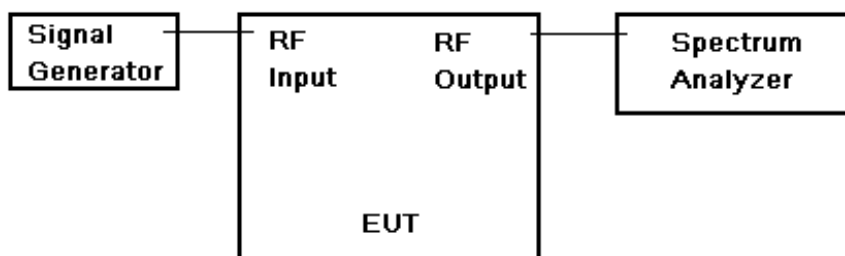
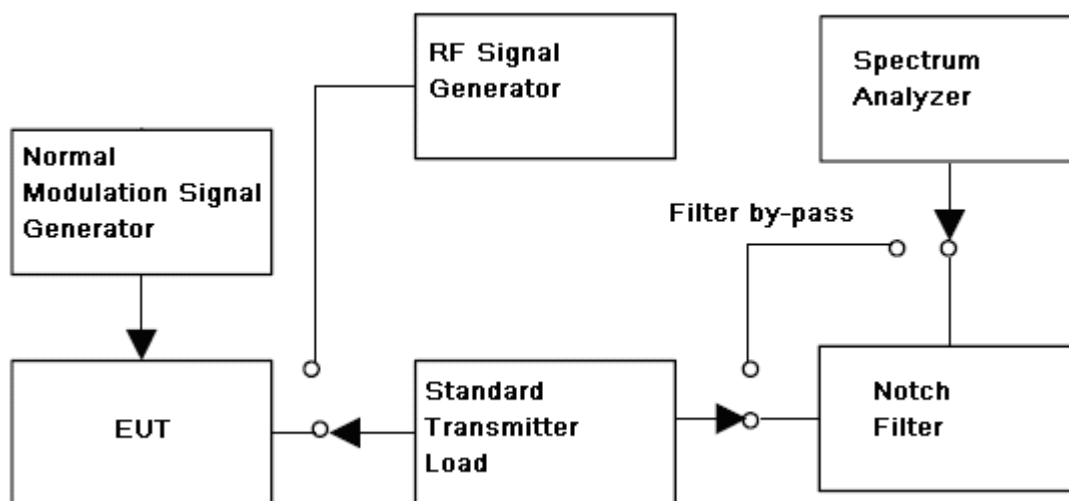

Fig.2. Conducted Spurious Emissions test configuration



Test Procedure:

Conducted Emissions test procedure:

- a) Connect the equipment as illustrated, with the notch filter by-passed, when the output power is over the max value of the Spectrum Analyzer, add the attenuator to avoid destroying the facility.
- b) Set the center frequency of the spectrum analyzer to the assigned transmitter frequency, key the transmitter, and set the level of the carrier to the full scale reference line.
- c) do not apply any tone to modulate the EUT.
- d) Adjust the spectrum analyzer for the following settings:
 - 1) Resolution Bandwidth,(base the standard, apply the different set),her is 100KHz for frequency band less than 1GHz, 1MHz for frequency over 1GHz;
 - 2) Video Bandwidth refer to standard requirement.
- e) Adjust the center frequency of the spectrum analyzer for incremental coverage of the range from:
 - 1) the lowest radio frequency generated in the equipment, it can be 9KHz base the test method, here select 30MHz as lowest frequency start point;
 - 2) the highest radion frequency shall higher than 10 times of carrier frequency;
- f) Record the frequencies and levels of spurious emissions from step e)

Remark:

The notch filter is used for avoid the EUT fundamental carrier output power making the spectrum overload and the harmonic spurious brought by it.

When the EUT fundamental carrier is not enough to make the status, the notch filter could be not used.

7.2.2.1 Measurement Record:

Cellular Band

Cellular—TDMA down link(lowest frequency)

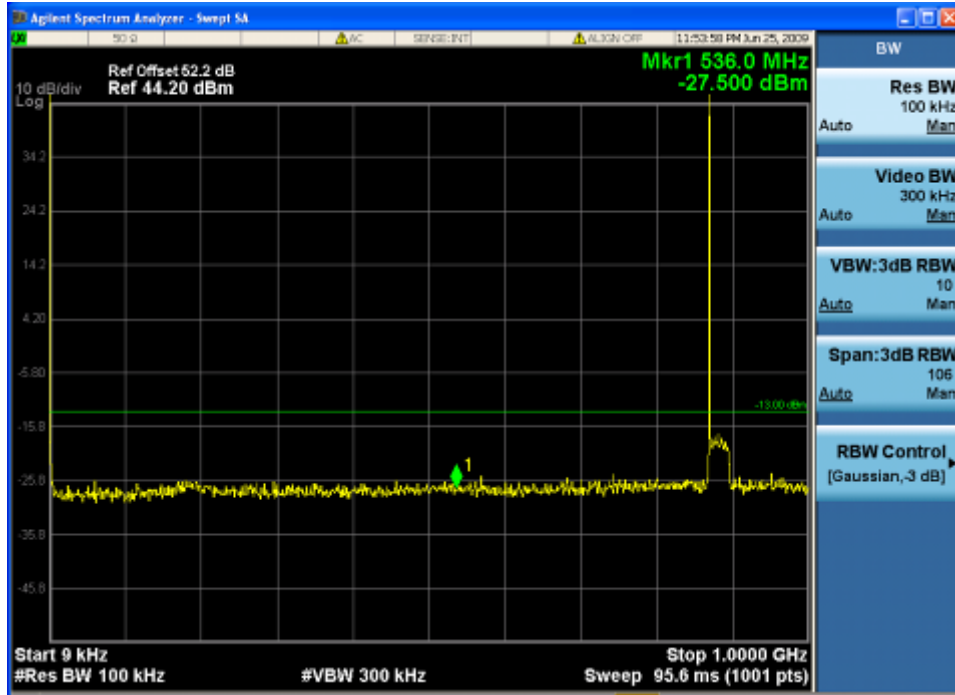

Cellular—TDMA down link(lowest frequency)

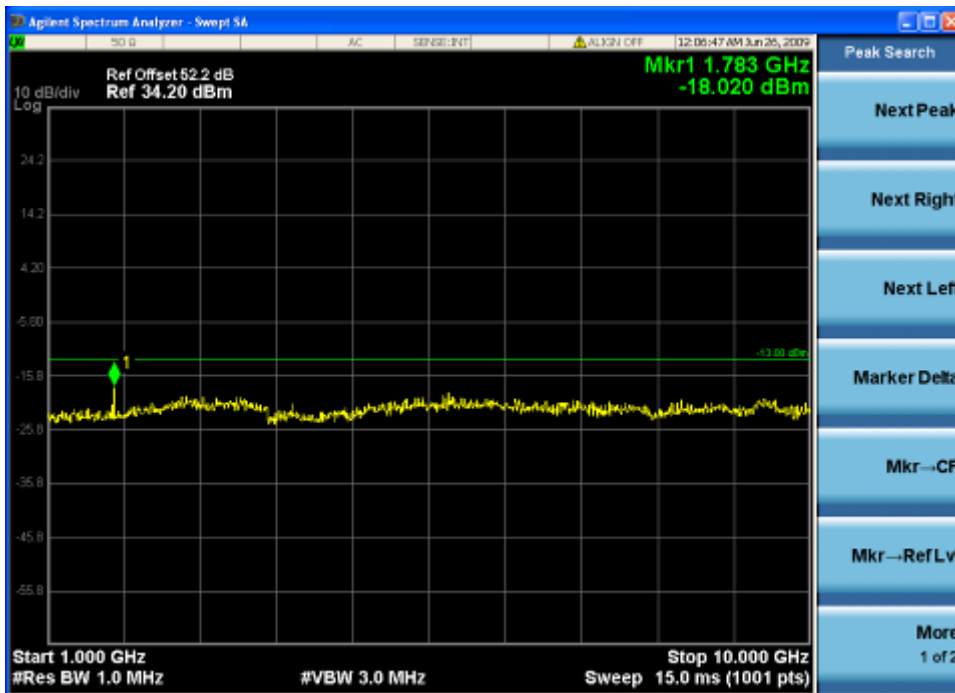

SGS-CSTC Standards Technical Services Co., Ltd.

Report No.: GLEMO09060172301

Page: 19 of 113

FCC ID: PX8TS-71-12XXXXXX

Cellular—TDMA down link(middle frequency)

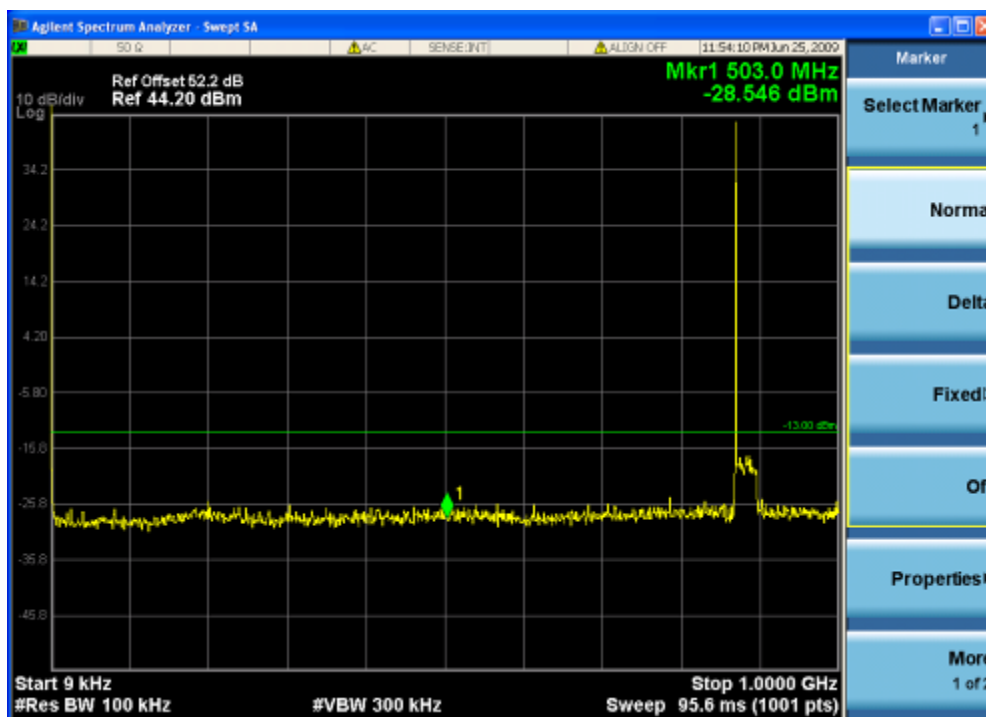

Cellular—TDMA down link(middle frequency)

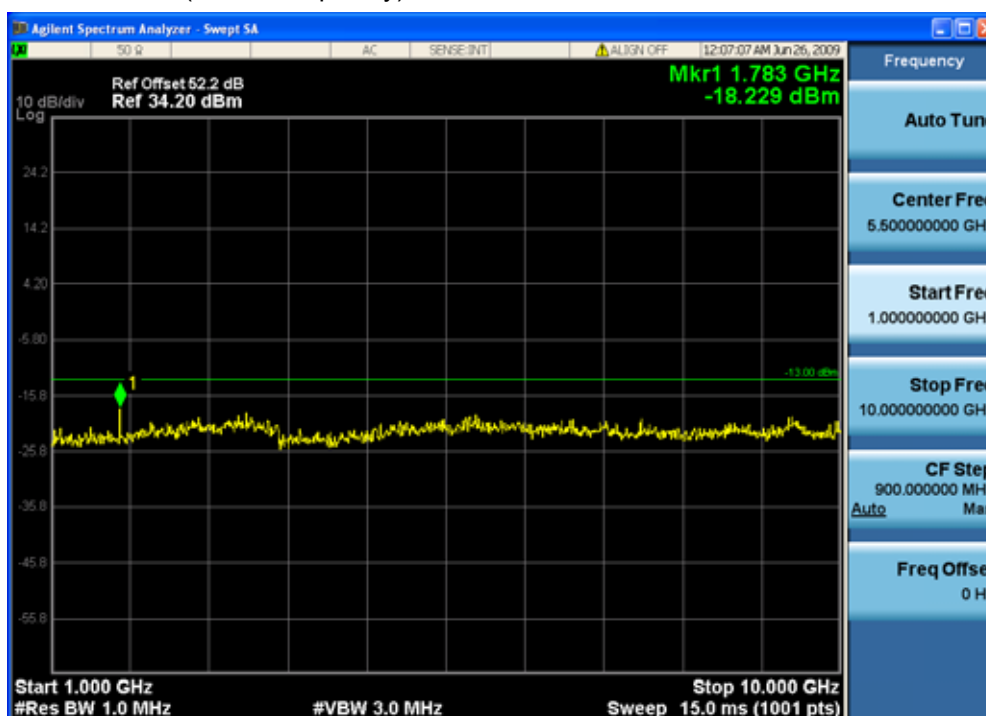

SGS-CSTC Standards Technical Services Co., Ltd.

Report No.: GLEMO09060172301

Page: 20 of 113

FCC ID: PX8TS-71-12XXXXXX

Cellular—TDMA down link(highest frequency)

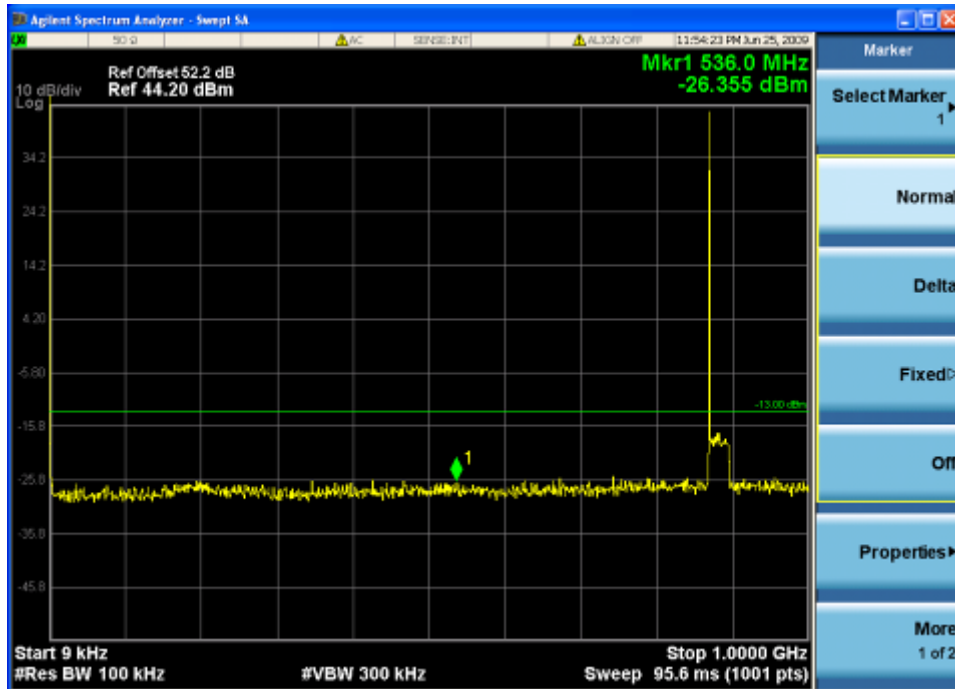

Cellular—TDMA down link(highest frequency)

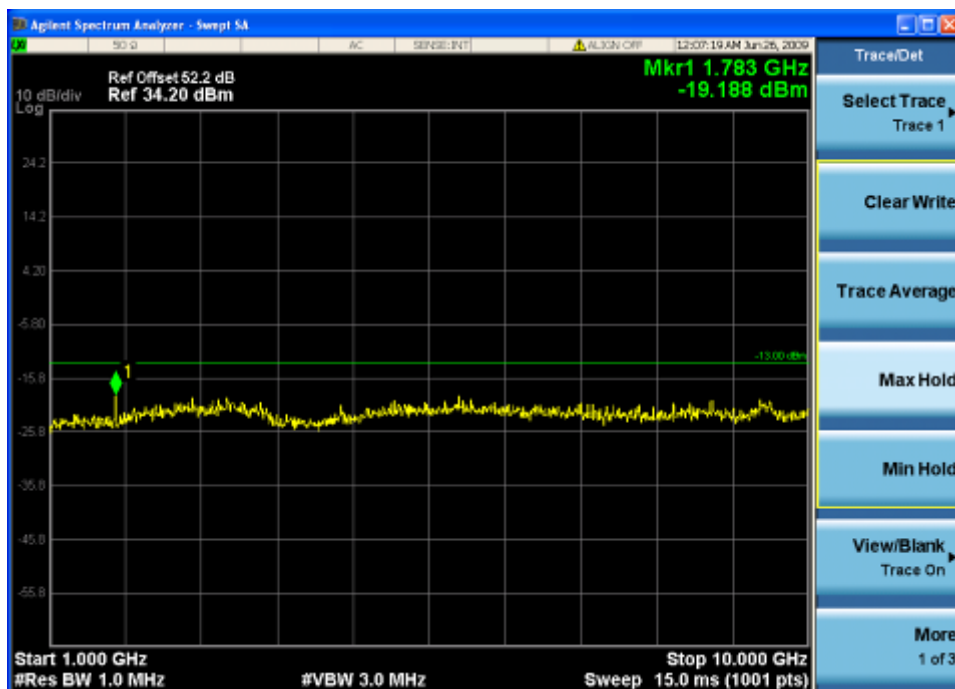

SGS-CSTC Standards Technical Services Co., Ltd.

Report No.: GLEMO09060172301

Page: 21 of 113

FCC ID: PX8TS-71-12XXXXXX

Cellular Band

Cellular—GSM down link(lowest frequency)

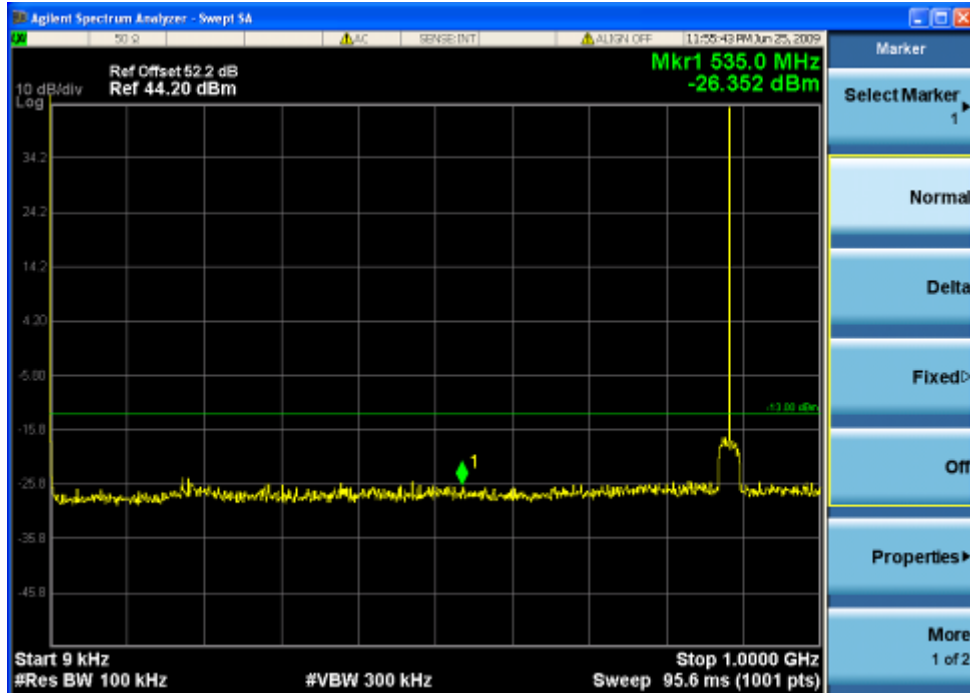

Cellular—GSM down link(lowest frequency)

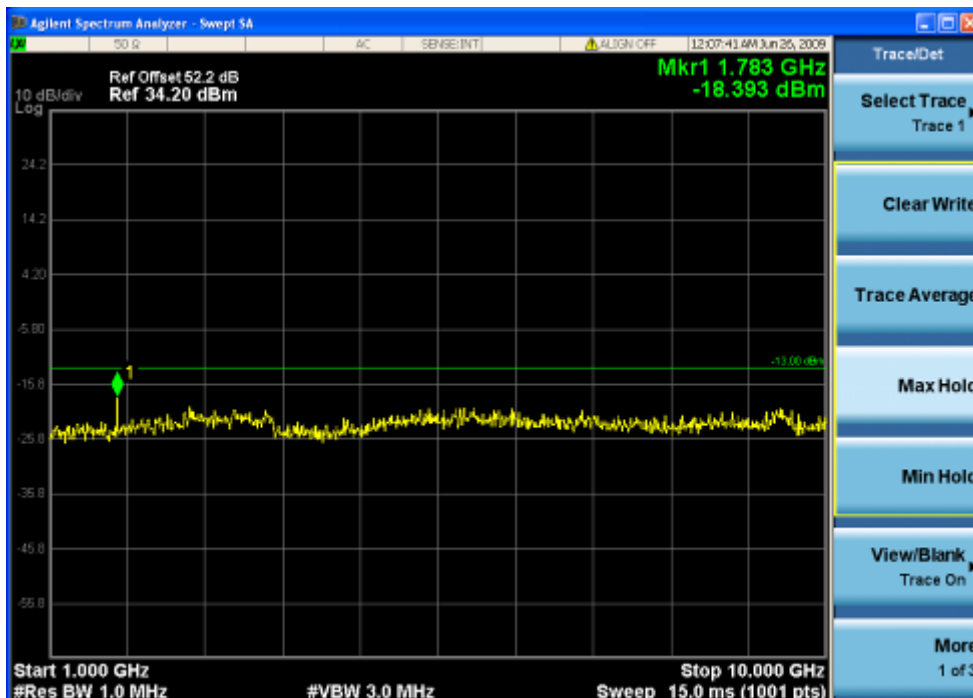

SGS-CSTC Standards Technical Services Co., Ltd.

Report No.: GLEMO09060172301

Page: 22 of 113

FCC ID: PX8TS-71-12XXXXXX

Cellular—GSM down link(middle frequency)

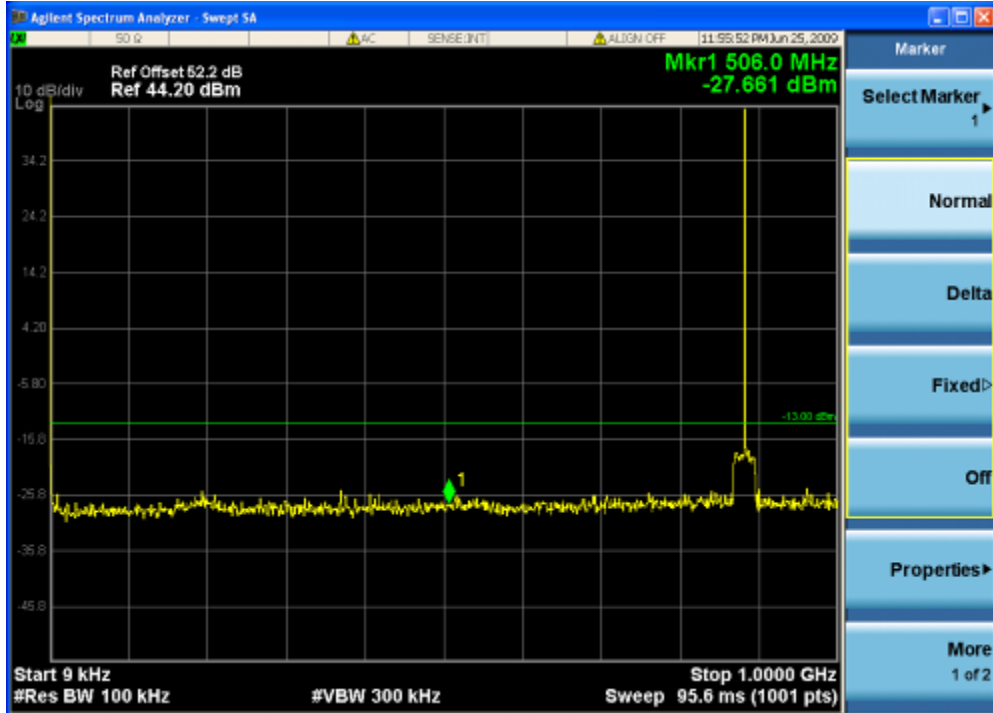

Cellular—GSM down link(middle frequency)

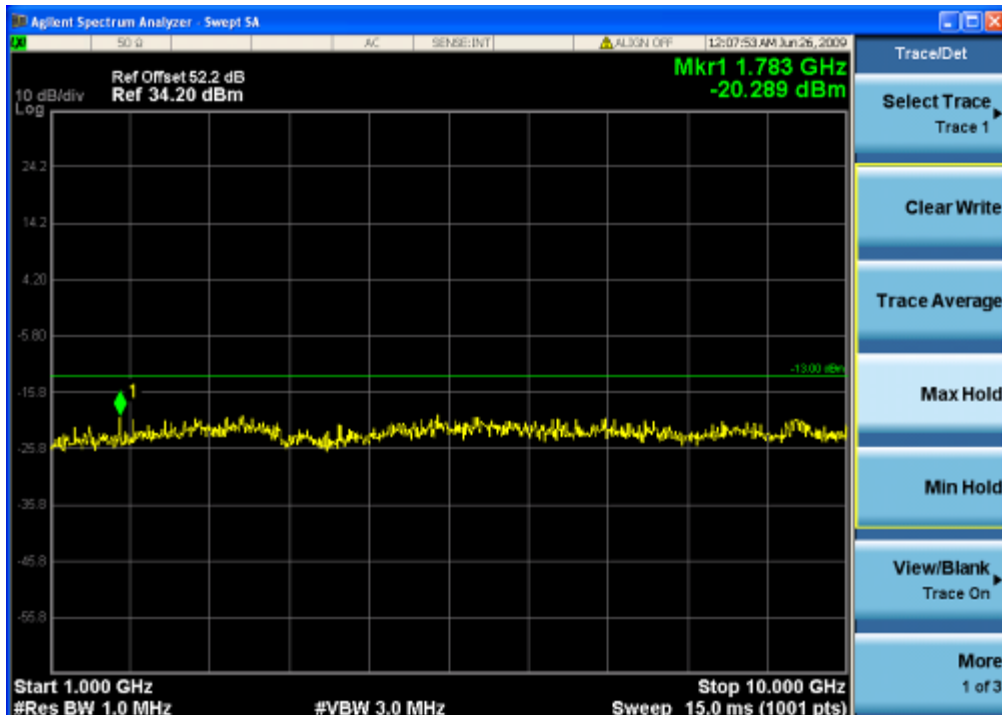

SGS-CSTC Standards Technical Services Co., Ltd.

Report No.: GLEMO09060172301

Page: 23 of 113

FCC ID: PX8TS-71-12XXXXXX

Cellular—GSM down link(highest frequency)

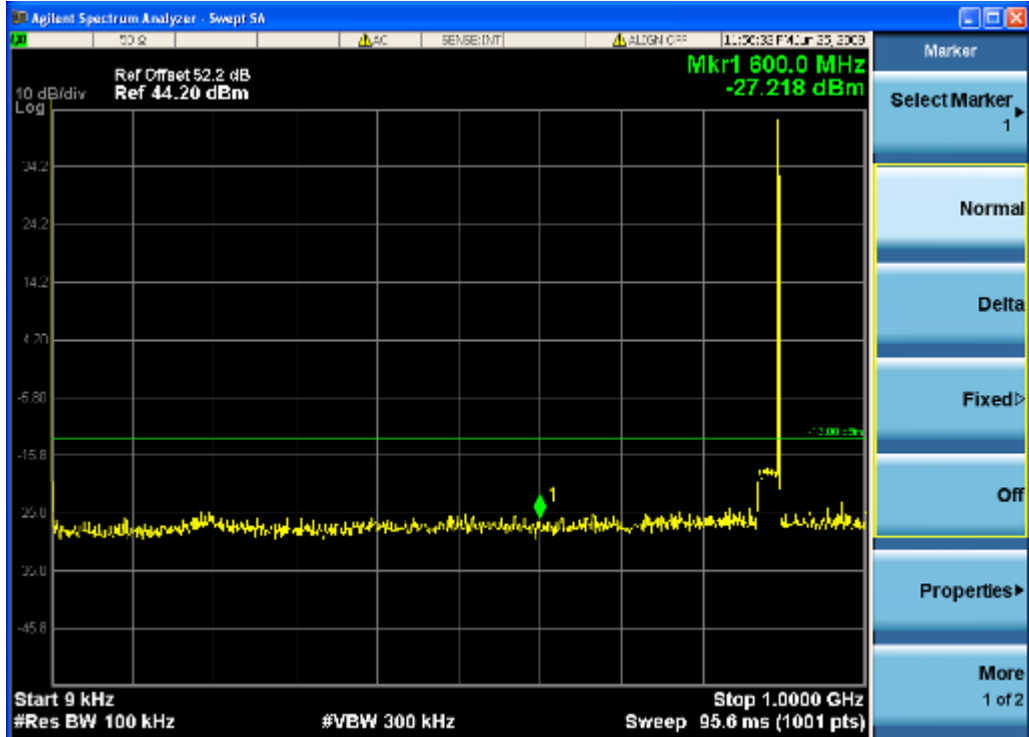

Cellular—GSM down link(highest frequency)

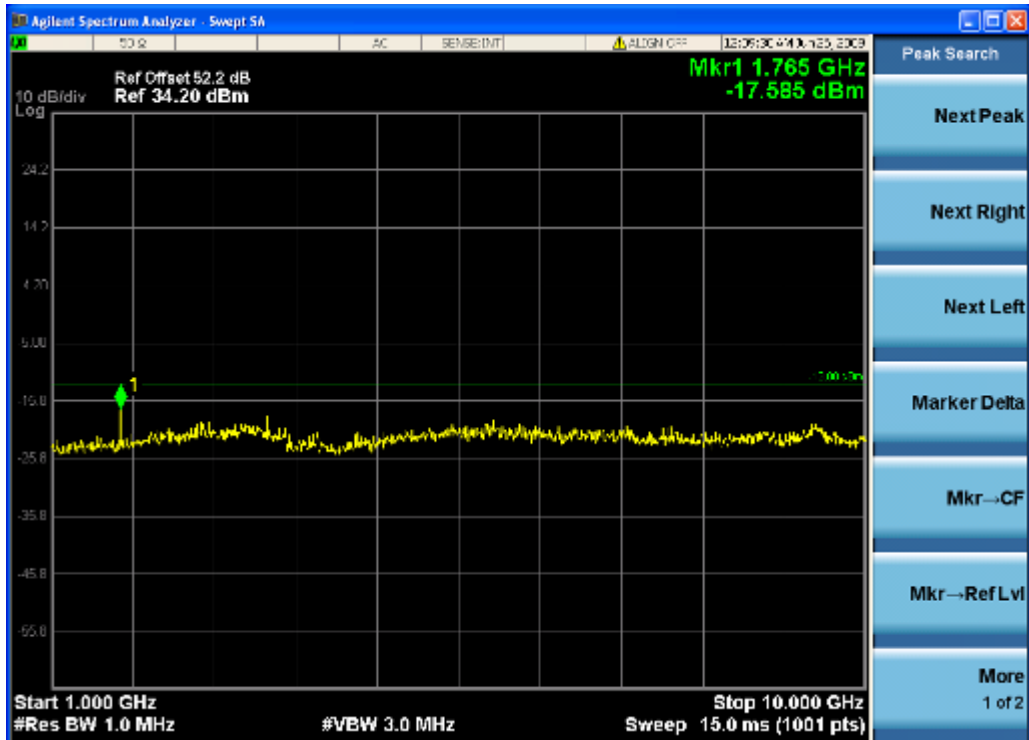

SGS-CSTC Standards Technical Services Co., Ltd.

Report No.: GLEMO09060172301

Page: 24 of 113

FCC ID: PX8TS-71-12XXXXXX

Cellular Band

Cellular—EDGE down link(lowest frequency)

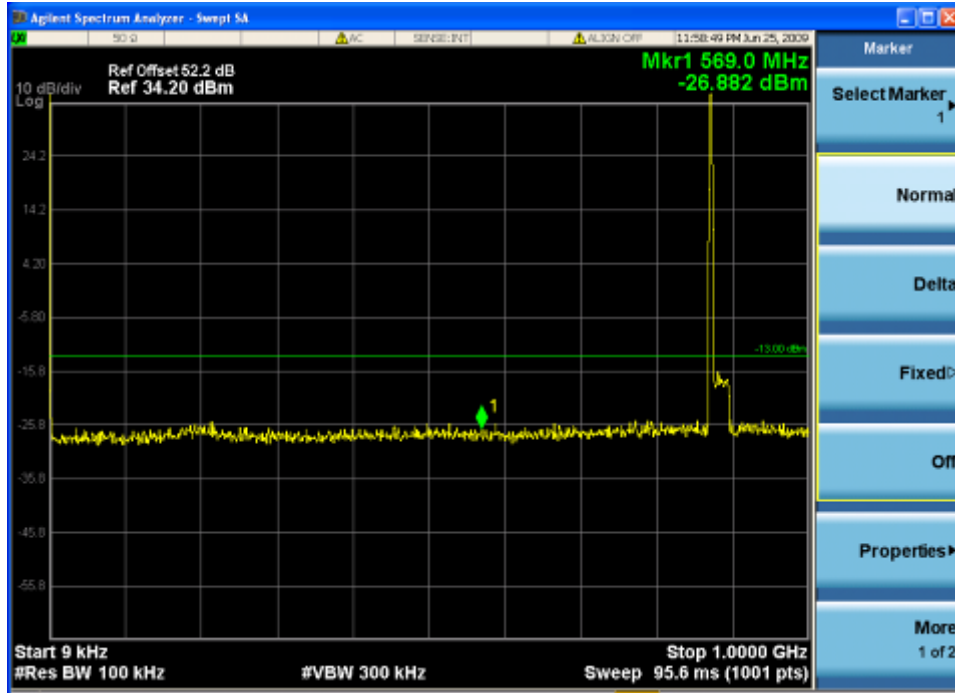

Cellular—EDGE down link(lowest frequency)

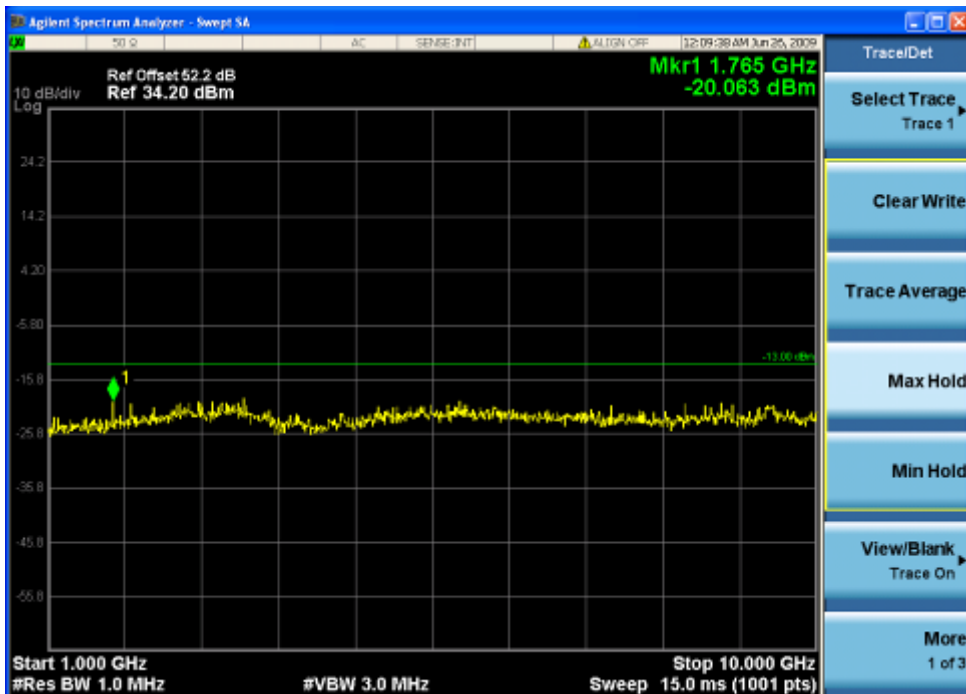

SGS-CSTC Standards Technical Services Co., Ltd.

Report No.: GLEMO09060172301

Page: 25 of 113

FCC ID: PX8TS-71-12XXXXXX

Cellular—EDGE down link(middle frequency)

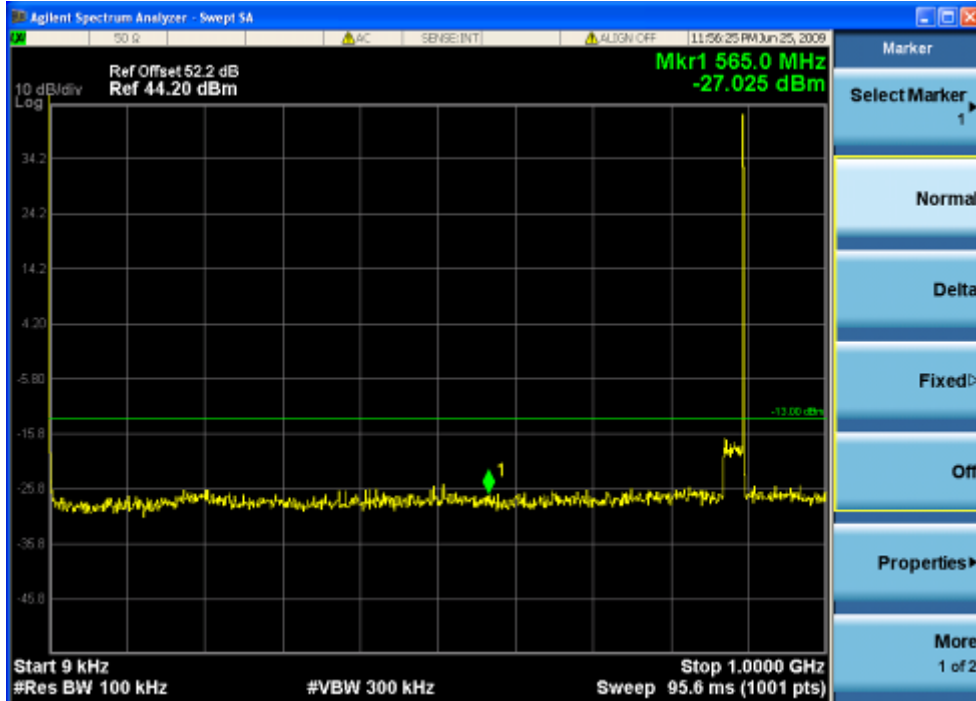

Cellular—EDGE down link(middle frequency)

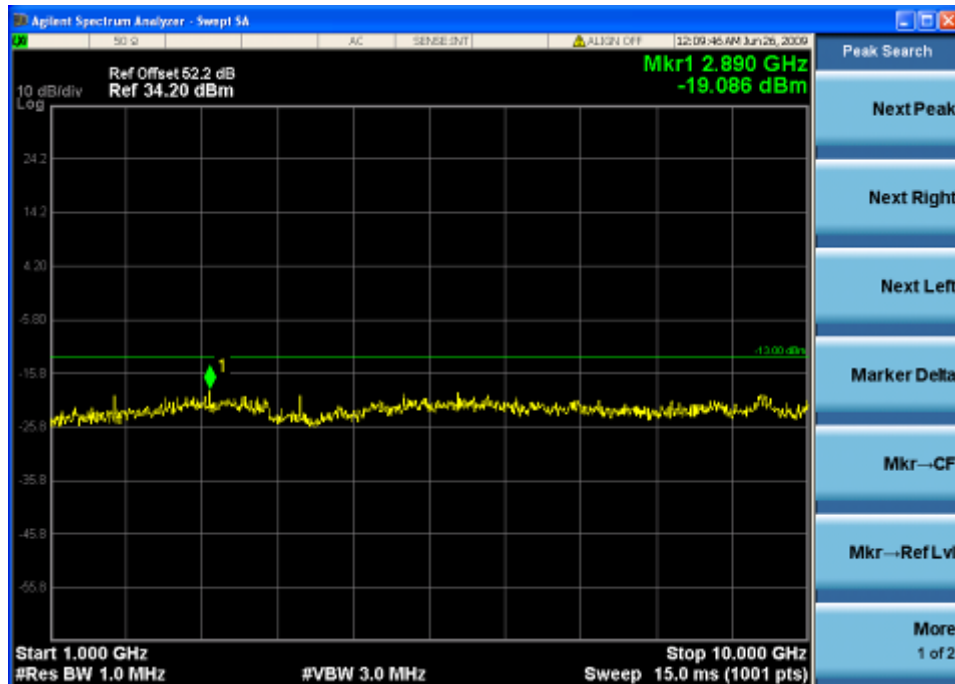

SGS-CSTC Standards Technical Services Co., Ltd.

Report No.: GLEMO09060172301

Page: 26 of 113

FCC ID: PX8TS-71-12XXXXXX

Cellular—EDGE down link(highest frequency)

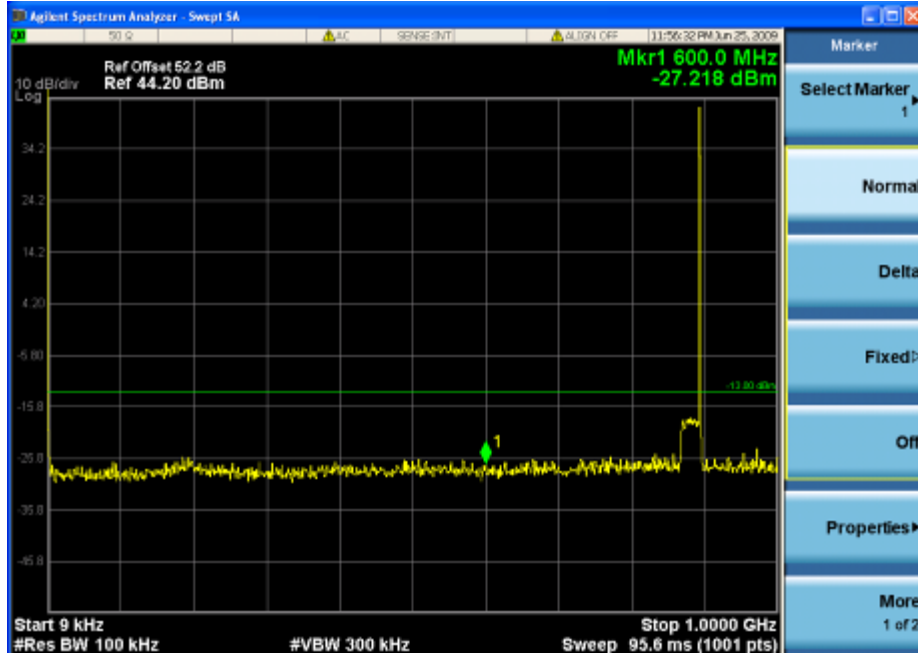

Cellular—EDGE down link(highest frequency)

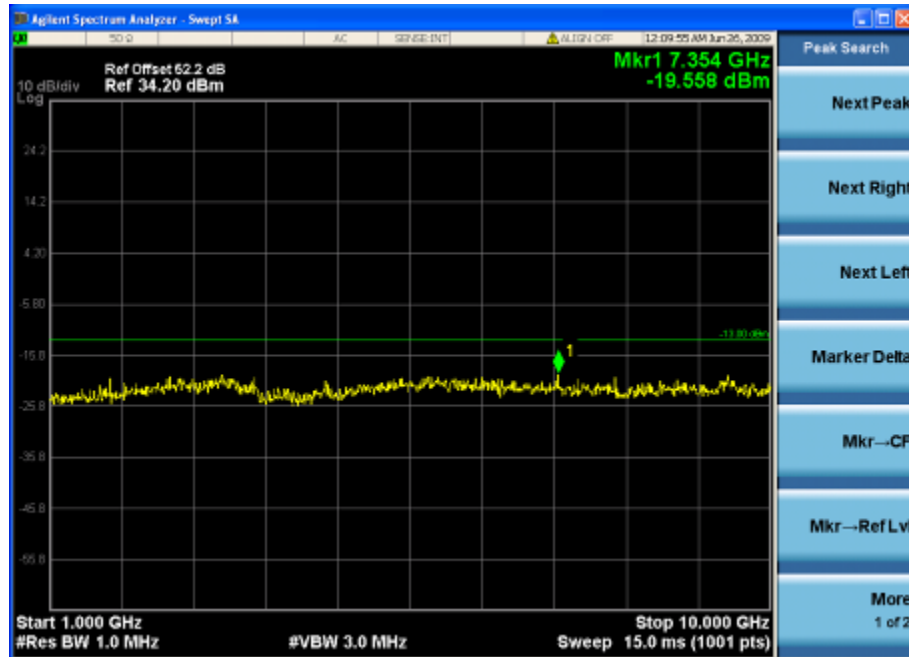

SGS-CSTC Standards Technical Services Co., Ltd.

Report No.: GLEMO09060172301

Page: 27 of 113

FCC ID: PX8TS-71-12XXXXXX

Cellular Band

Cellular—CDMA down link(lowest frequency)

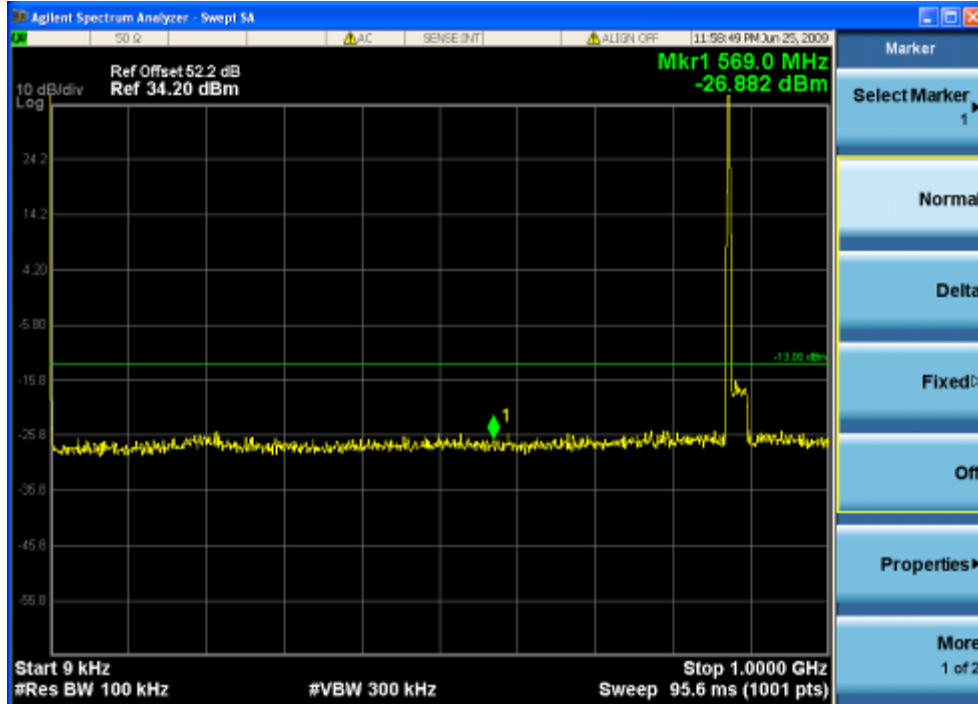

Cellular—CDMA down link(lowest frequency)

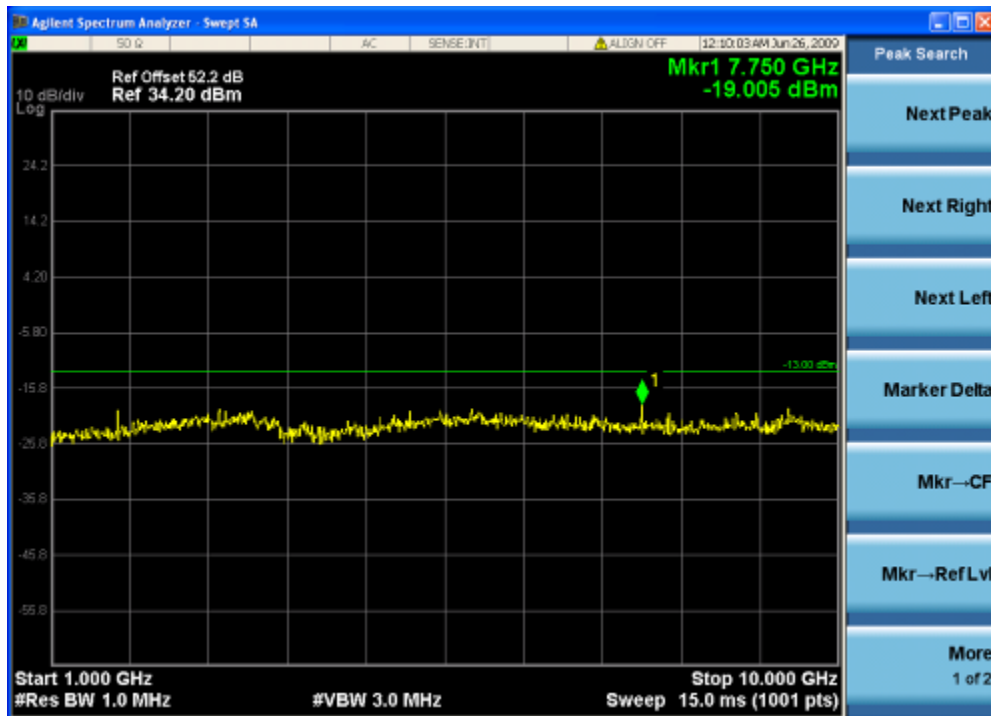

SGS-CSTC Standards Technical Services Co., Ltd.

Report No.: GLEMO09060172301

Page: 28 of 113

FCC ID: PX8TS-71-12XXXXXX

Cellular—CDMA down link(middle frequency)

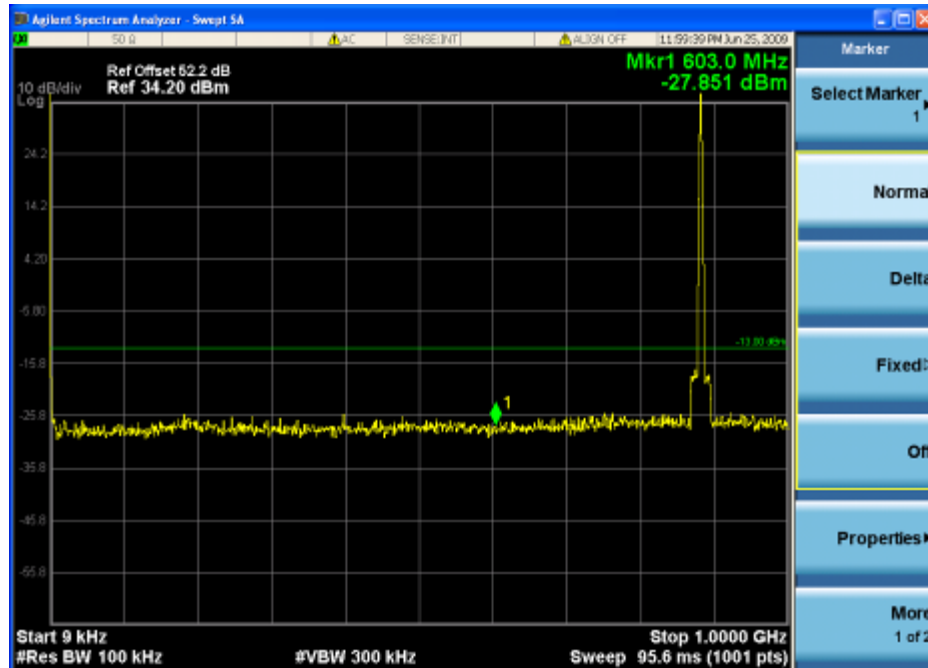

Cellular—CDMA down link(middle frequency)

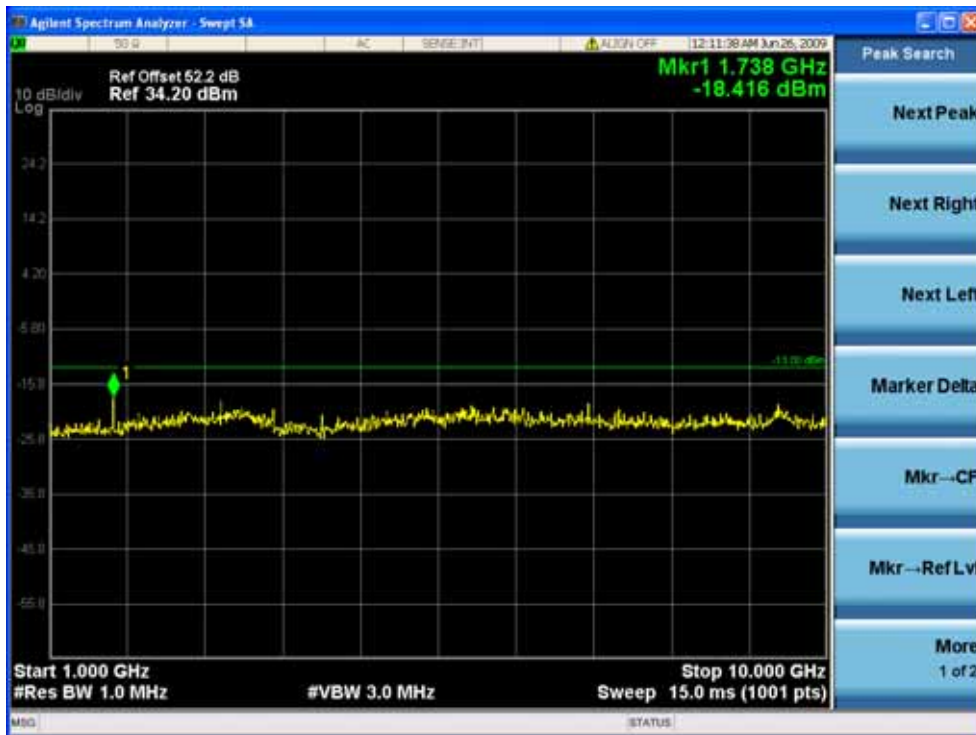

SGS-CSTC Standards Technical Services Co., Ltd.

Report No.: GLEMO09060172301

Page: 29 of 113

FCC ID: PX8TS-71-12XXXXXX

Cellular—CDMA down link(highest frequency)

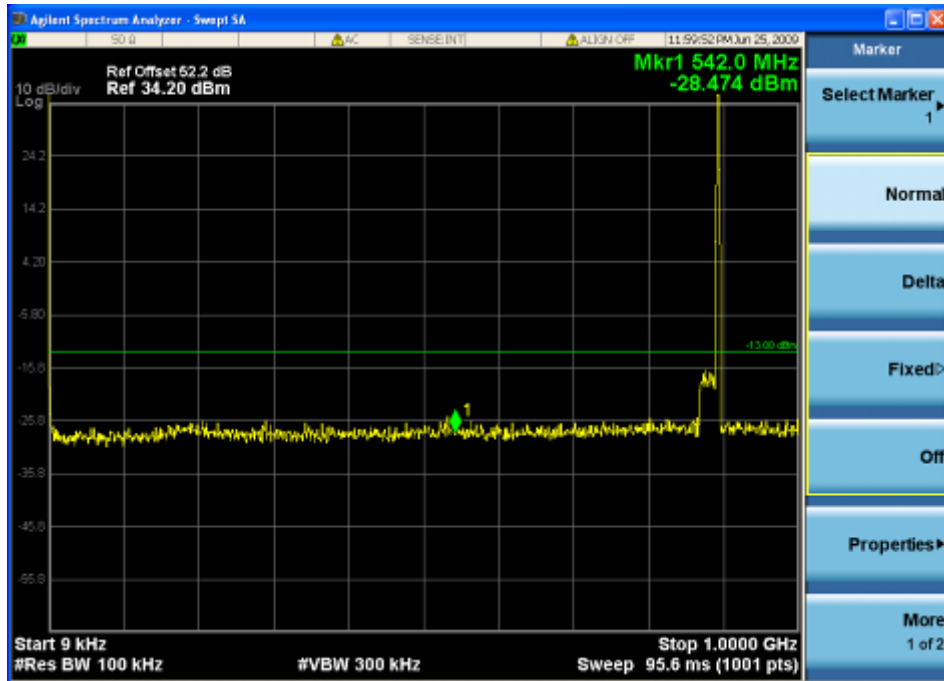

Cellular—CDMA down link(highest frequency)

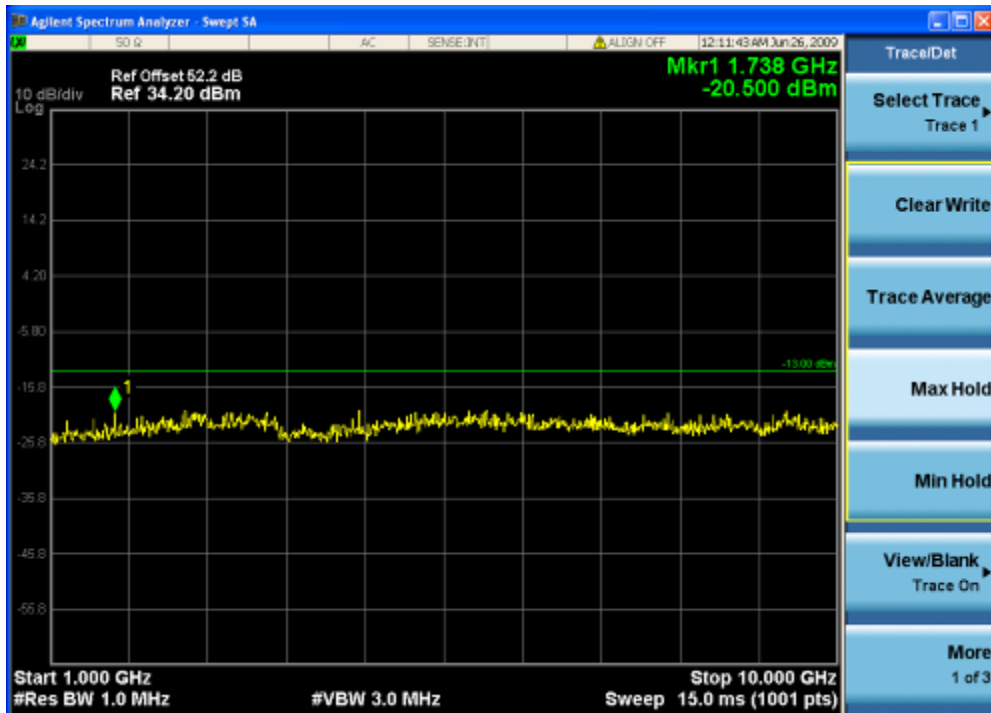

SGS-CSTC Standards Technical Services Co., Ltd.

Report No.: GLEMO09060172301

Page: 30 of 113

FCC ID: PX8TS-71-12XXXXXX

Cellular Band

Cellular—WCDMA down link(lowest frequency)

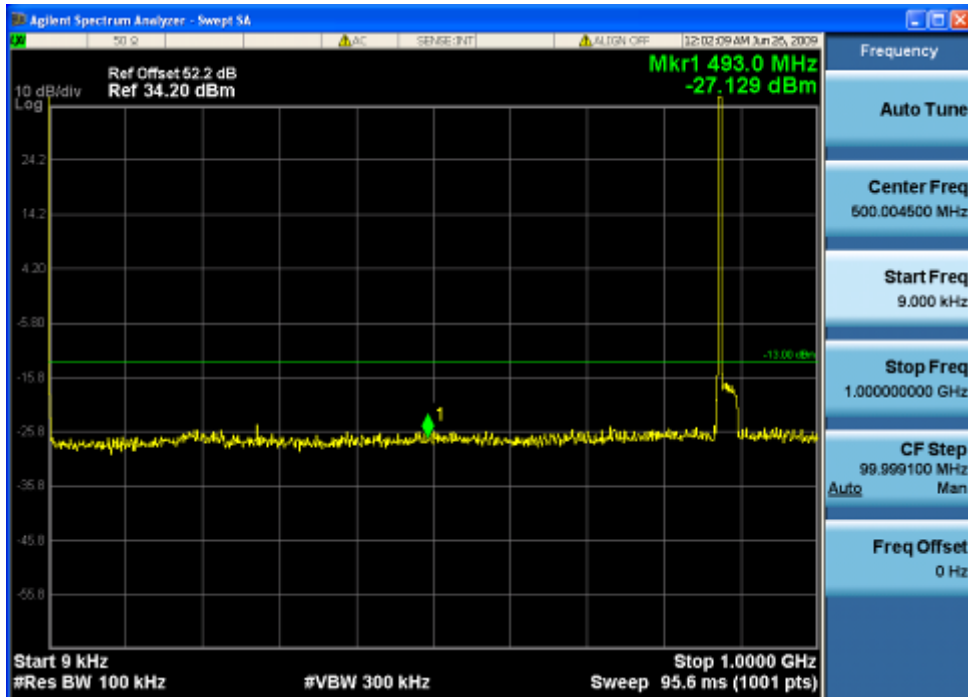

Cellular—WCDMA down link(lowest frequency)



SGS-CSTC Standards Technical Services Co., Ltd.

Report No.: GLEMO09060172301

Page: 31 of 113

FCC ID: PX8TS-71-12XXXXXX

Cellular—WCDMA down link(middle frequency)

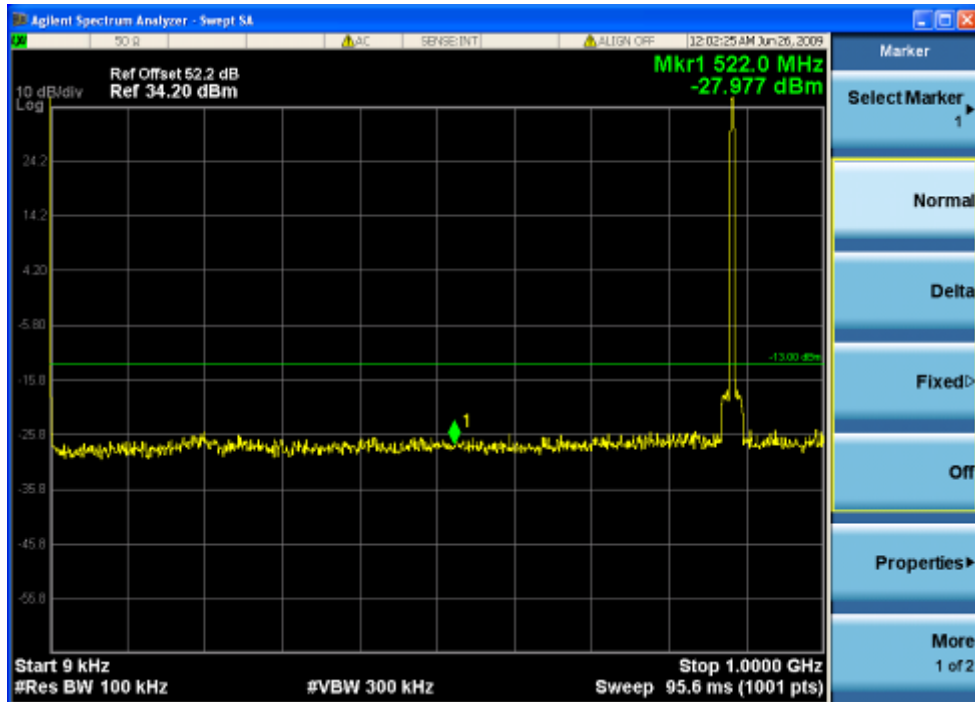

Cellular—WCDMA down link(middle frequency)



SGS-CSTC Standards Technical Services Co., Ltd.

Report No.: GLEMO09060172301

Page: 32 of 113

FCC ID: PX8TS-71-12XXXXXX

Cellular—WCDMA down link(highest frequency)

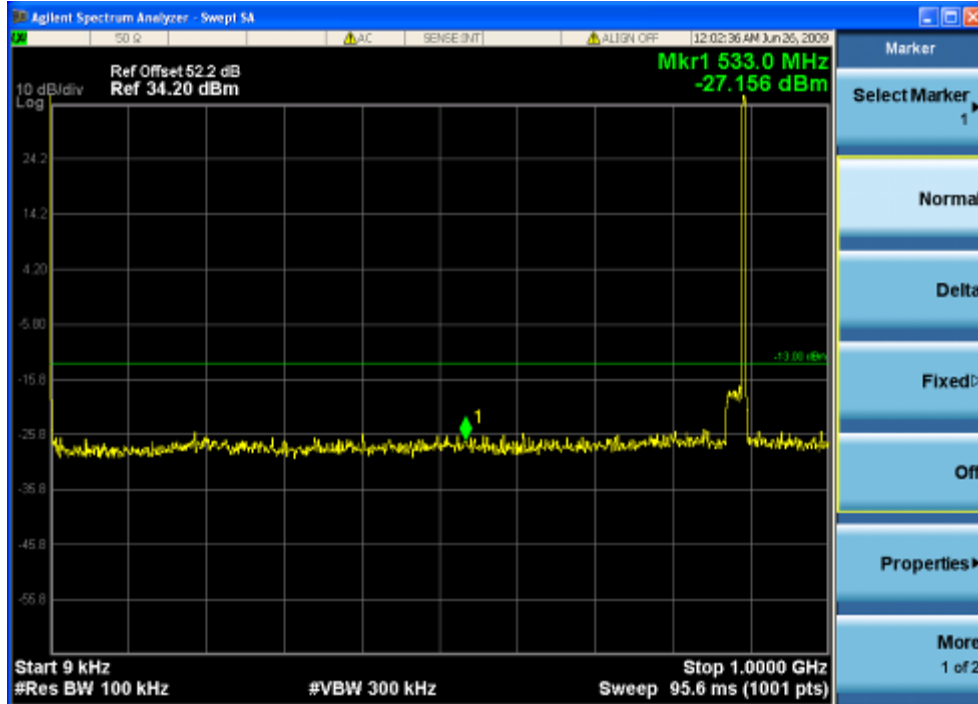

Cellular—WCDMA down link(highest frequency)

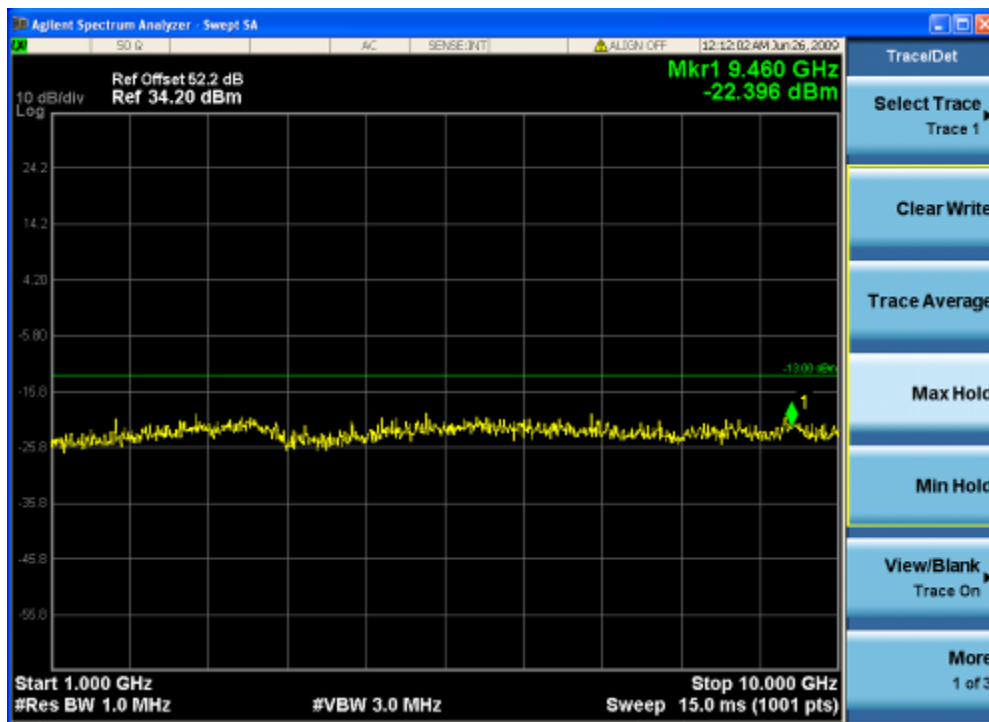

SGS-CSTC Standards Technical Services Co., Ltd.

Report No.: GLEMO09060172301

Page: 33 of 113

FCC ID: PX8TS-71-12XXXXXX

PCS Band

PCS—TDMA down link(lowest frequency)

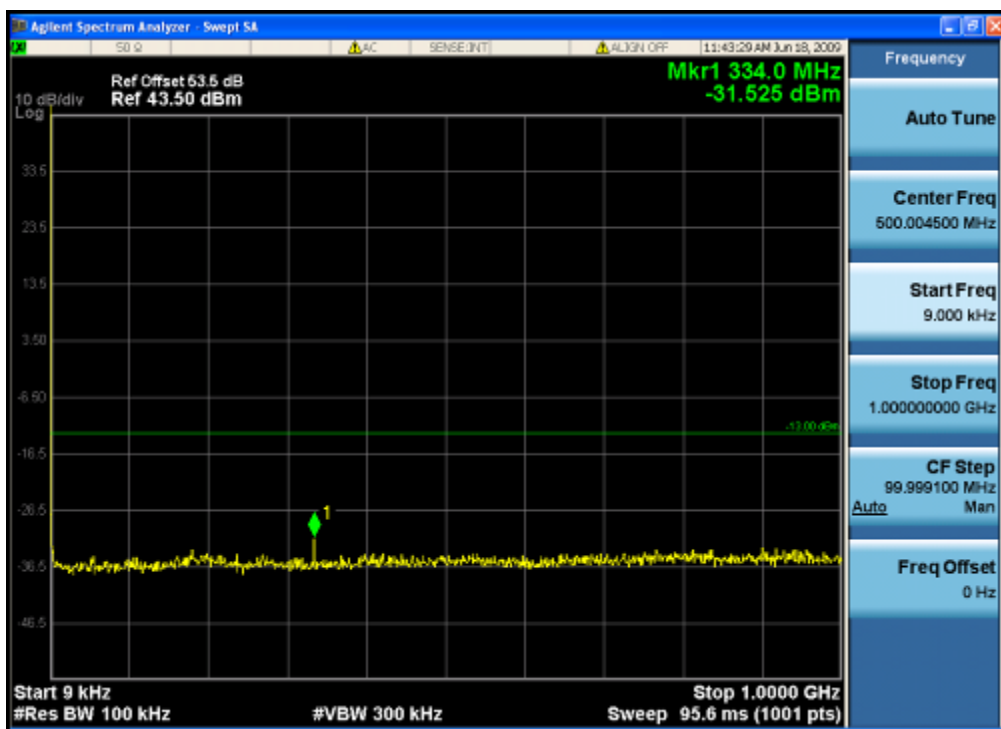

PCS—TDMA down link(lowest frequency)



SGS-CSTC Standards Technical Services Co., Ltd.

Report No.: GLEMO09060172301

Page: 34 of 113

FCC ID: PX8TS-71-12XXXXXX

PCS—TDMA down link(middle frequency)

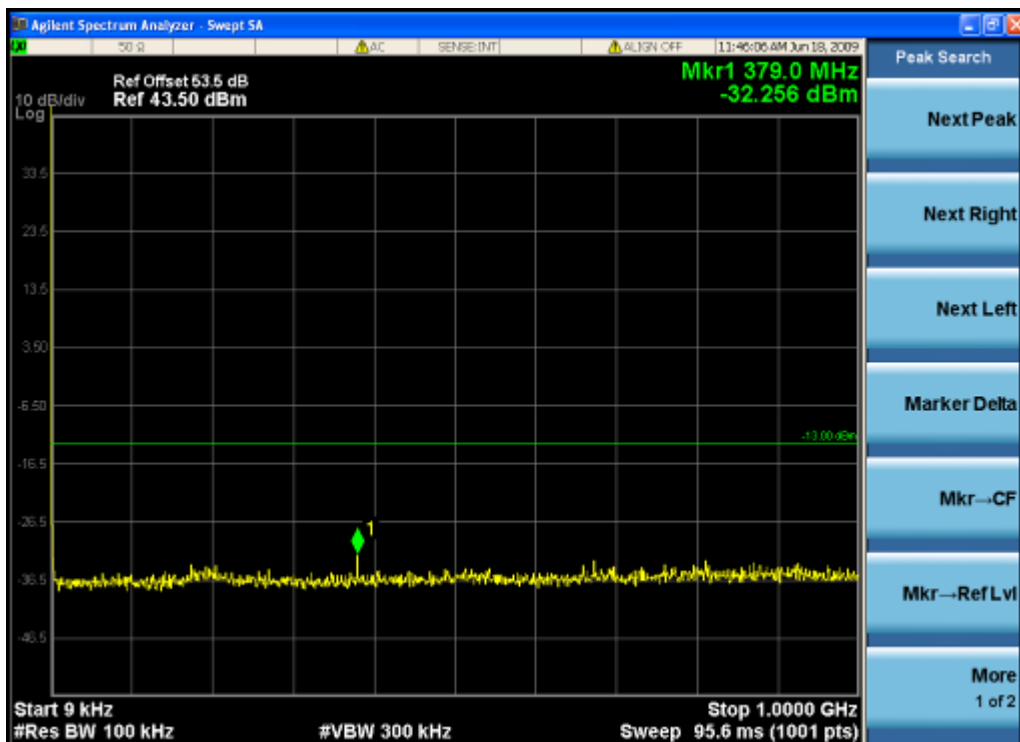

PCS—TDMA down link(middle frequency)

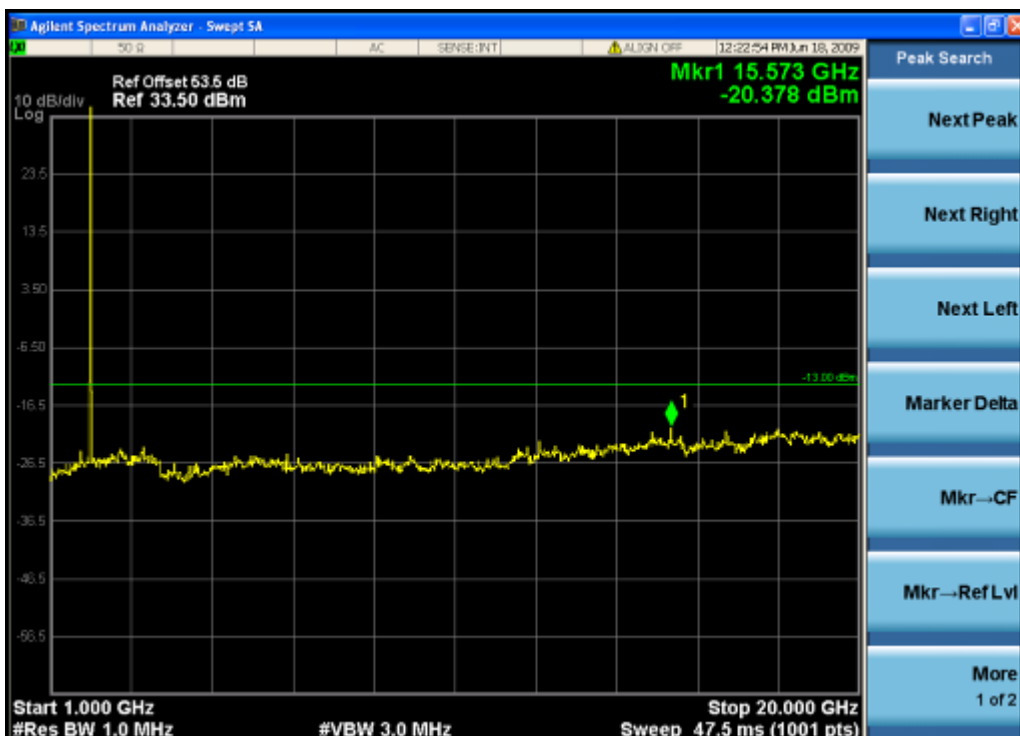

SGS-CSTC Standards Technical Services Co., Ltd.

Report No.: GLEMO09060172301

Page: 35 of 113

FCC ID: PX8TS-71-12XXXXXX

PCS—TDMA down link(highest frequency)

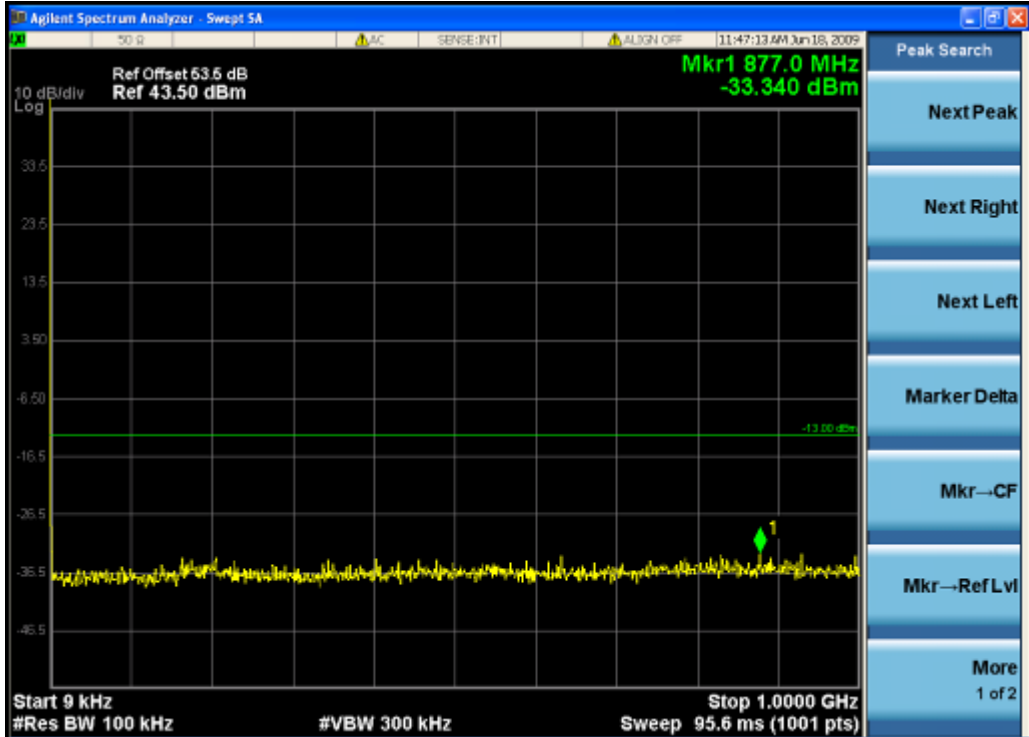

PCS—TDMA down link(highest frequency)

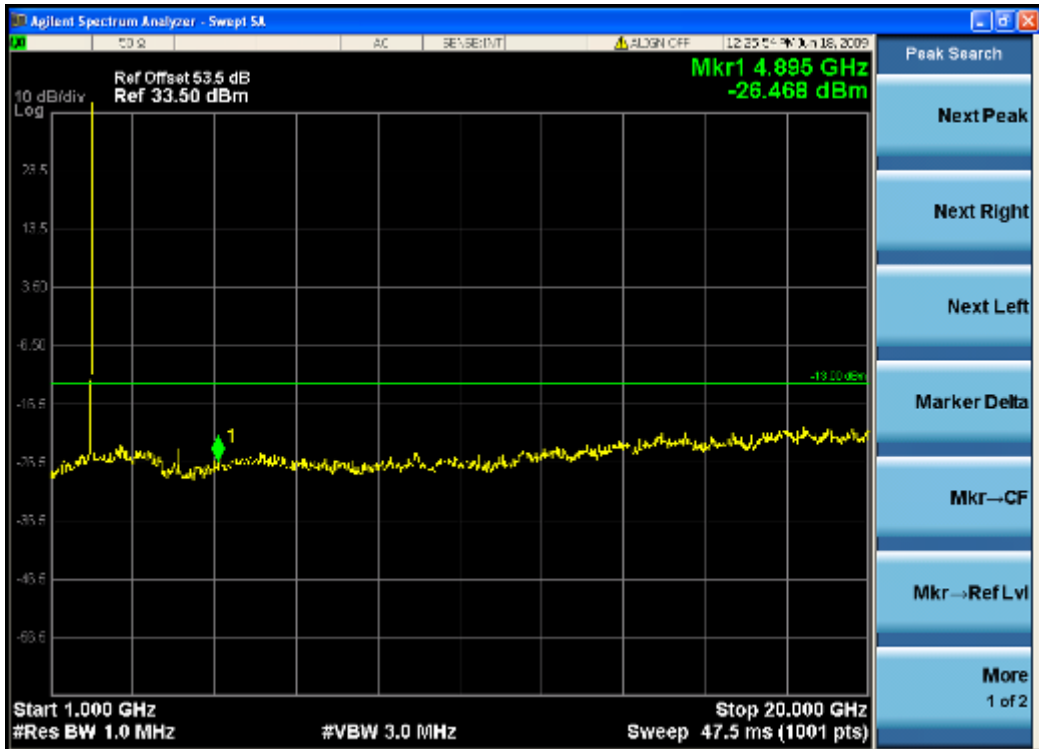

SGS-CSTC Standards Technical Services Co., Ltd.

Report No.: GLEMO09060172301

Page: 36 of 113

FCC ID: PX8TS-71-12XXXXXX

PCS Band

PCS—GSM down link(lowest frequency)

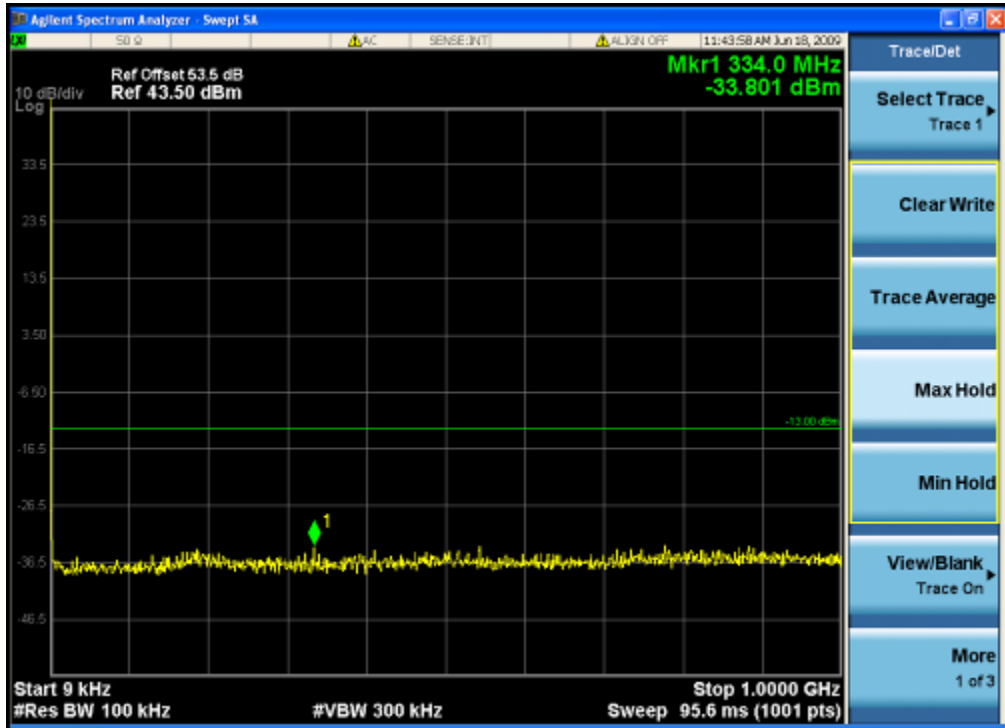

PCS—GSM down link(lowest frequency)



SGS-CSTC Standards Technical Services Co., Ltd.

Report No.: GLEMO09060172301

Page: 37 of 113

FCC ID: PX8TS-71-12XXXXXX

PCS—GSM down link(middle frequency)

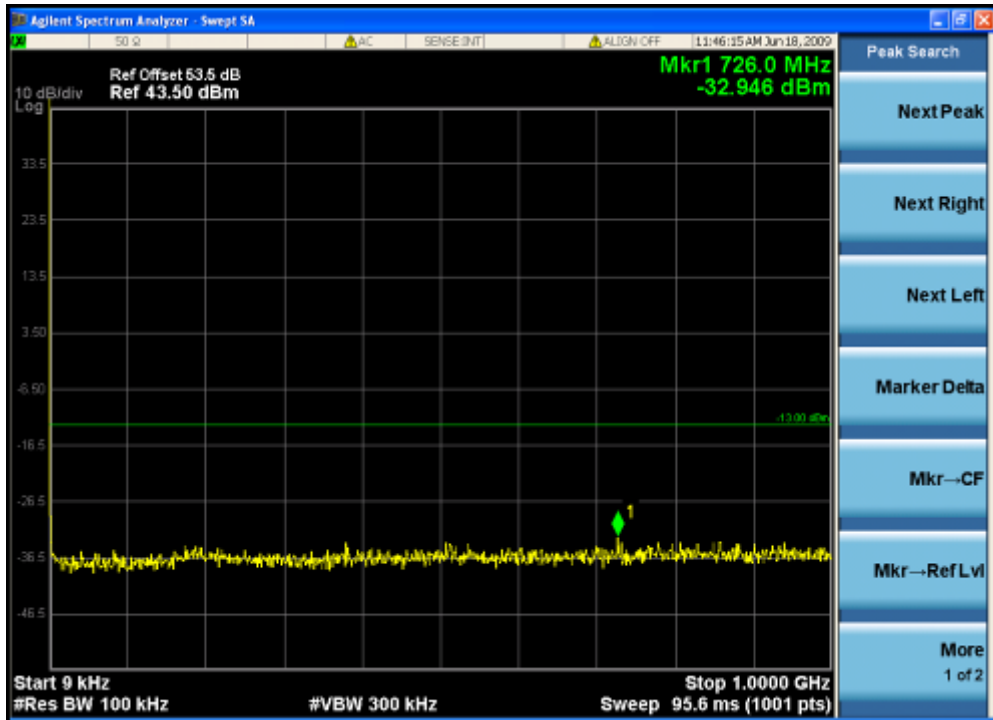

PCS—GSM down link(middle frequency)



SGS-CSTC Standards Technical Services Co., Ltd.

Report No.: GLEMO09060172301

Page: 38 of 113

FCC ID: PX8TS-71-12XXXXXX

PCS—GSM down link(highest frequency)

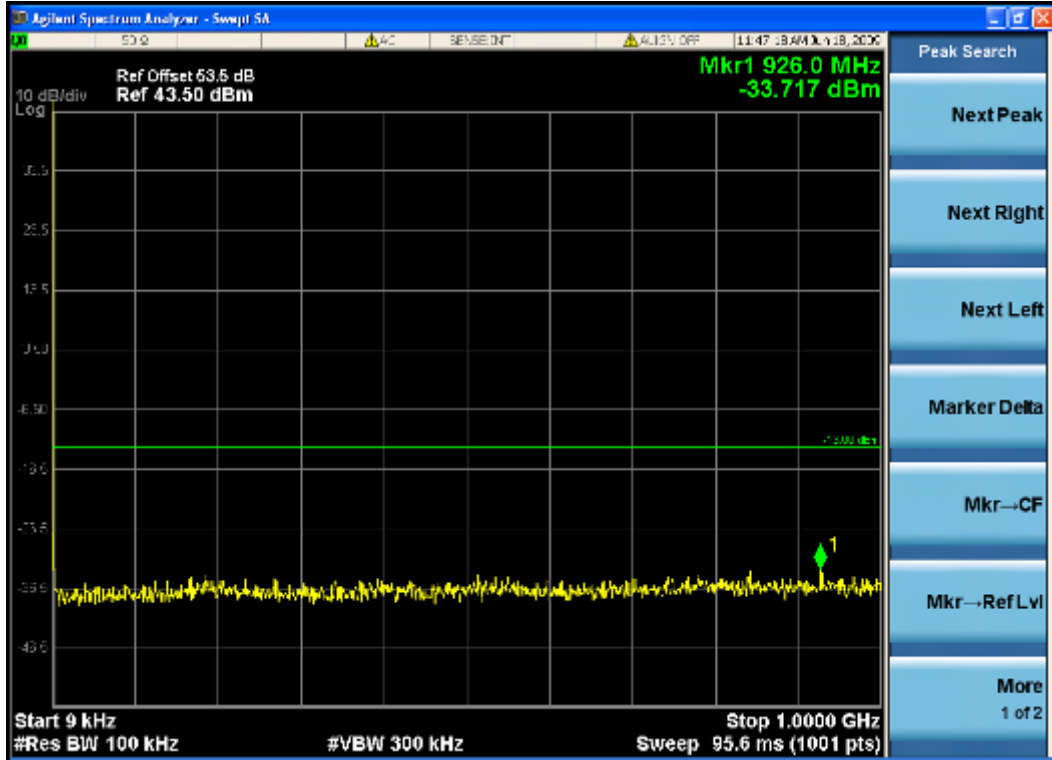

PCS—GSM down link(highest frequency)



SGS-CSTC Standards Technical Services Co., Ltd.

Report No.: GLEMO09060172301

Page: 39 of 113

FCC ID: PX8TS-71-12XXXXXX

PCS Band

PCS—EDGE down link(lowest frequency)

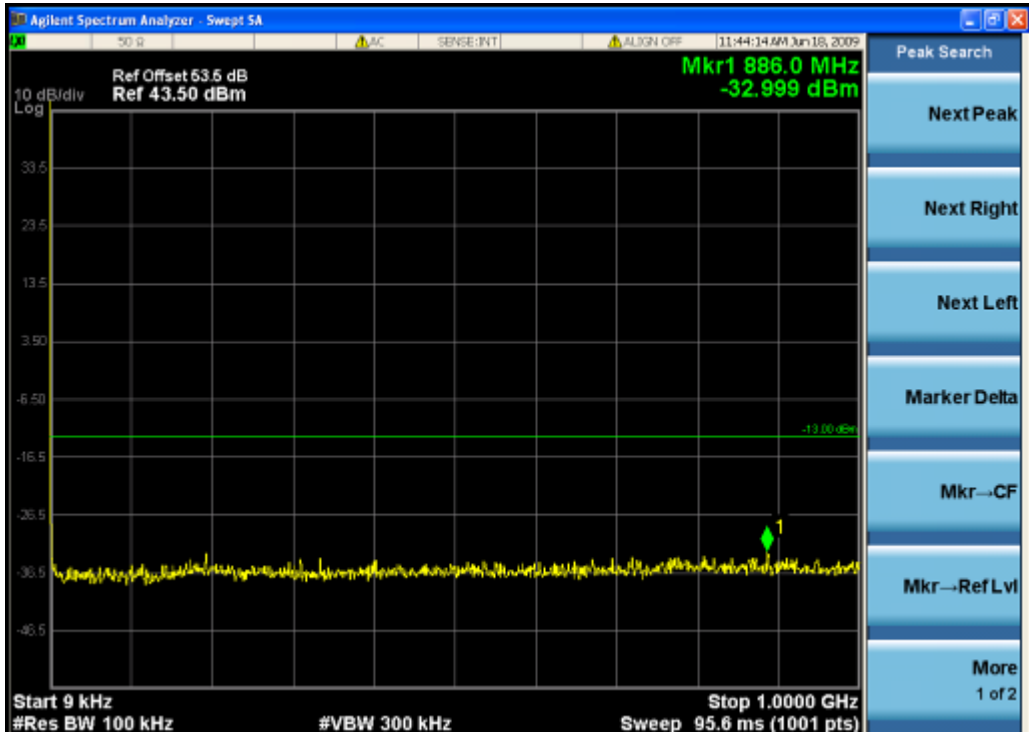

PCS—EDGE down link(lowest frequency)



SGS-CSTC Standards Technical Services Co., Ltd.

Report No.: GLEMO09060172301

Page: 40 of 113

FCC ID: PX8TS-71-12XXXXXX

PCS—EDGE down link(middle frequency)

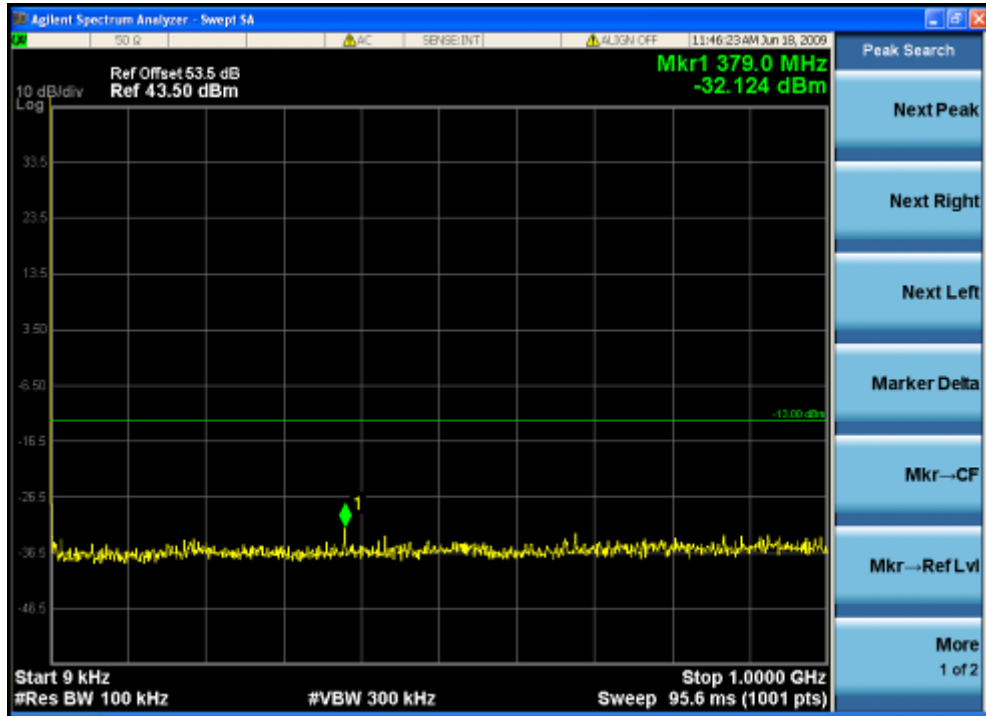

PCS—EDGE down link(middle frequency)



SGS-CSTC Standards Technical Services Co., Ltd.

Report No.: GLEMO09060172301

Page: 41 of 113

FCC ID: PX8TS-71-12XXXXXX

PCS—EDGE down link(highest frequency)

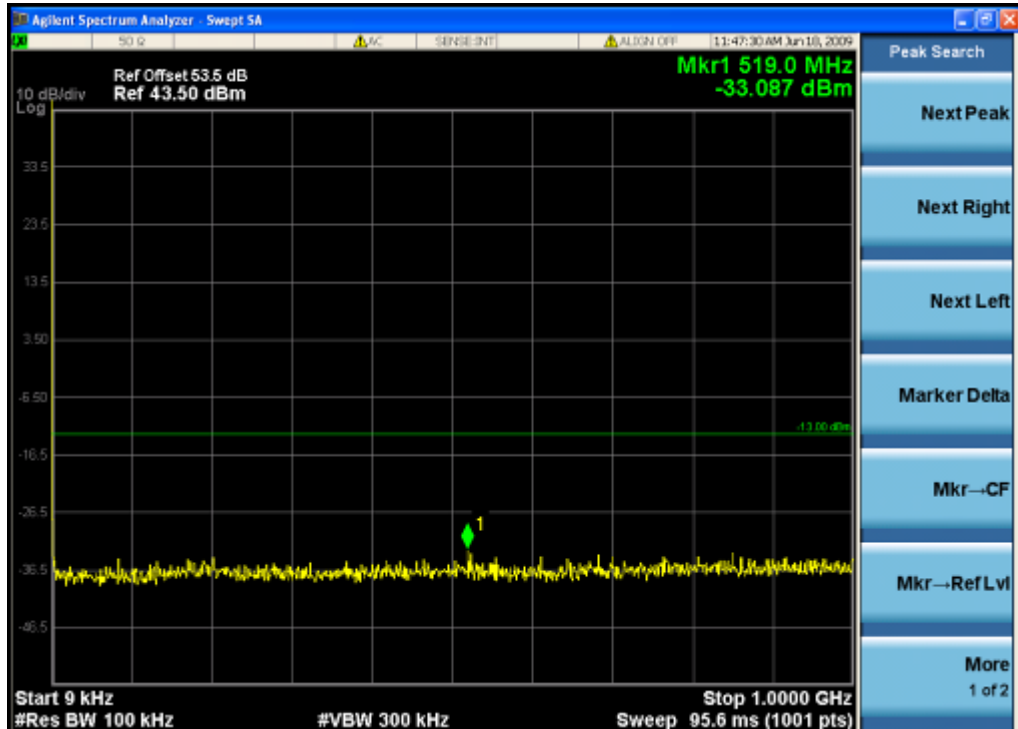

PCS—EDGE down link(highest frequency)

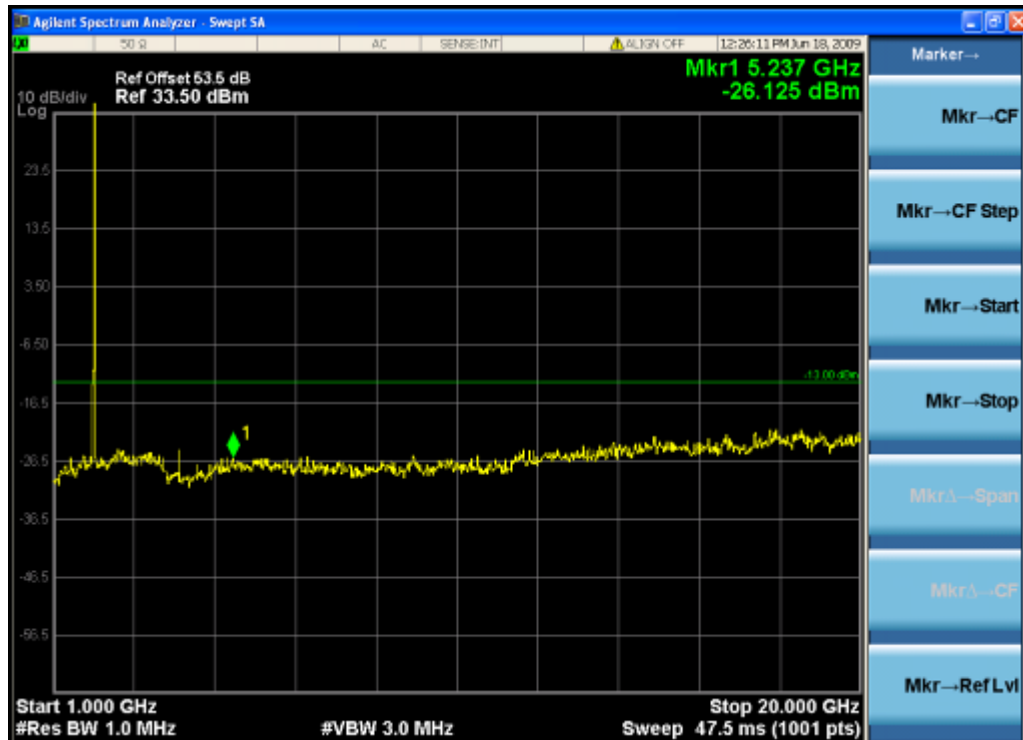

SGS-CSTC Standards Technical Services Co., Ltd.

Report No.: GLEMO09060172301

Page: 42 of 113

FCC ID: PX8TS-71-12XXXXXX

PCS Band

PCS—CDMA down link(lowest frequency)

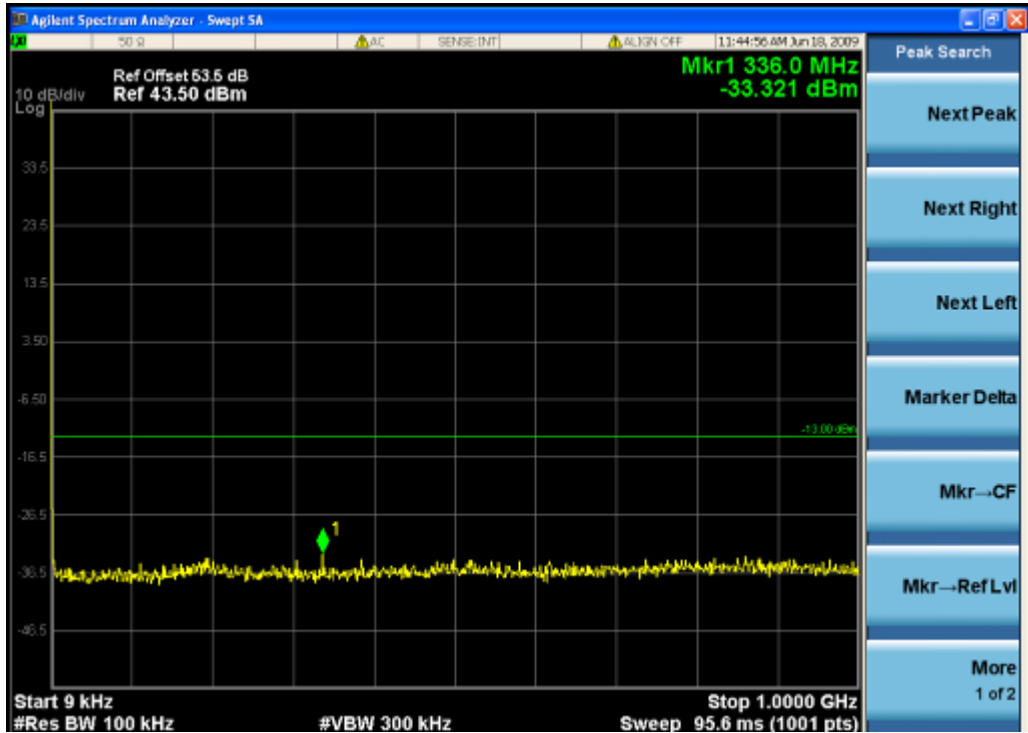

PCS—CDMA down link(lowest frequency)

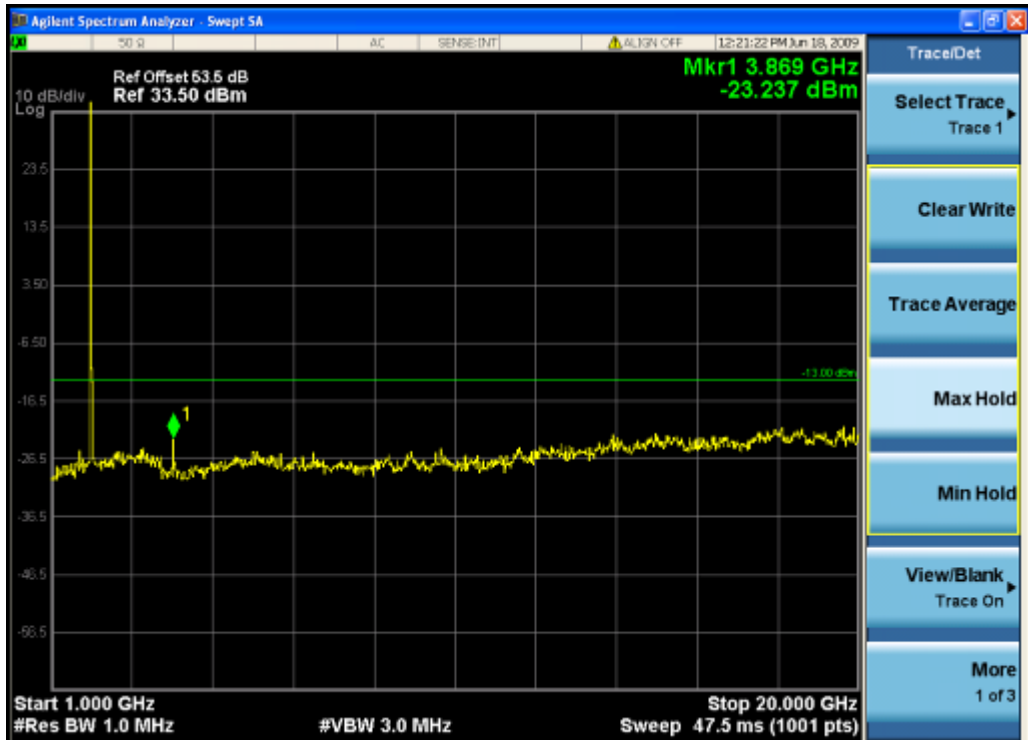

SGS-CSTC Standards Technical Services Co., Ltd.

Report No.: GLEMO09060172301

Page: 43 of 113

FCC ID: PX8TS-71-12XXXXXX

PCS—CDMA down link(middle frequency)

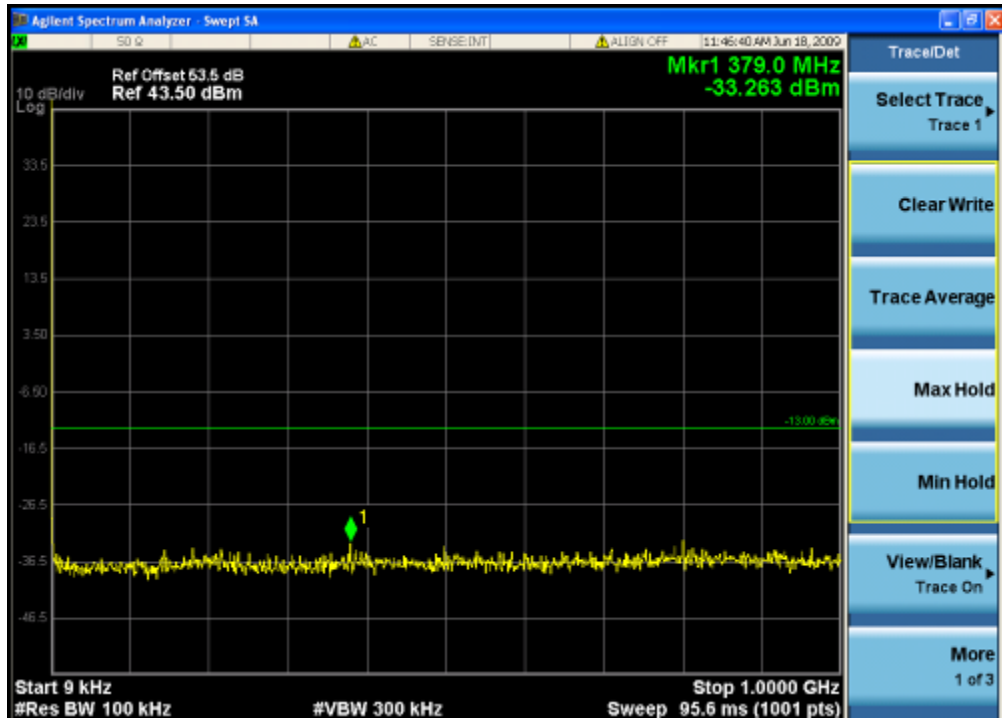

PCS—CDMA down link(middle frequency)



SGS-CSTC Standards Technical Services Co., Ltd.

Report No.: GLEMO09060172301

Page: 44 of 113

FCC ID: PX8TS-71-12XXXXXX

PCS—CDMA down link(highest frequency)

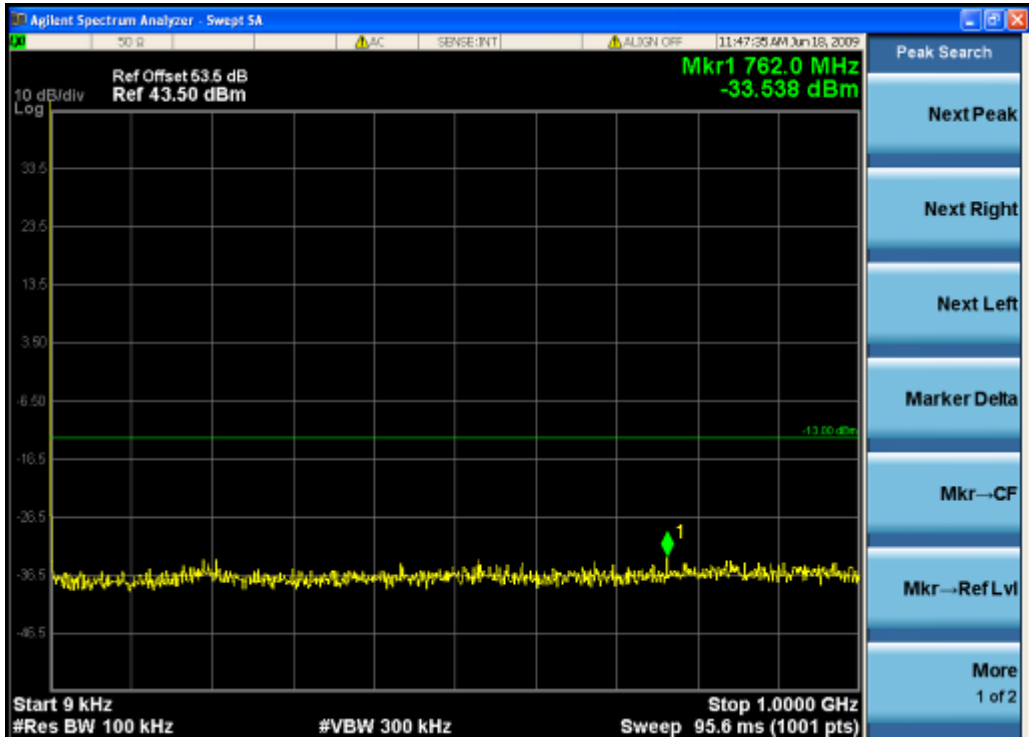

PCS—CDMA down link(highest frequency)

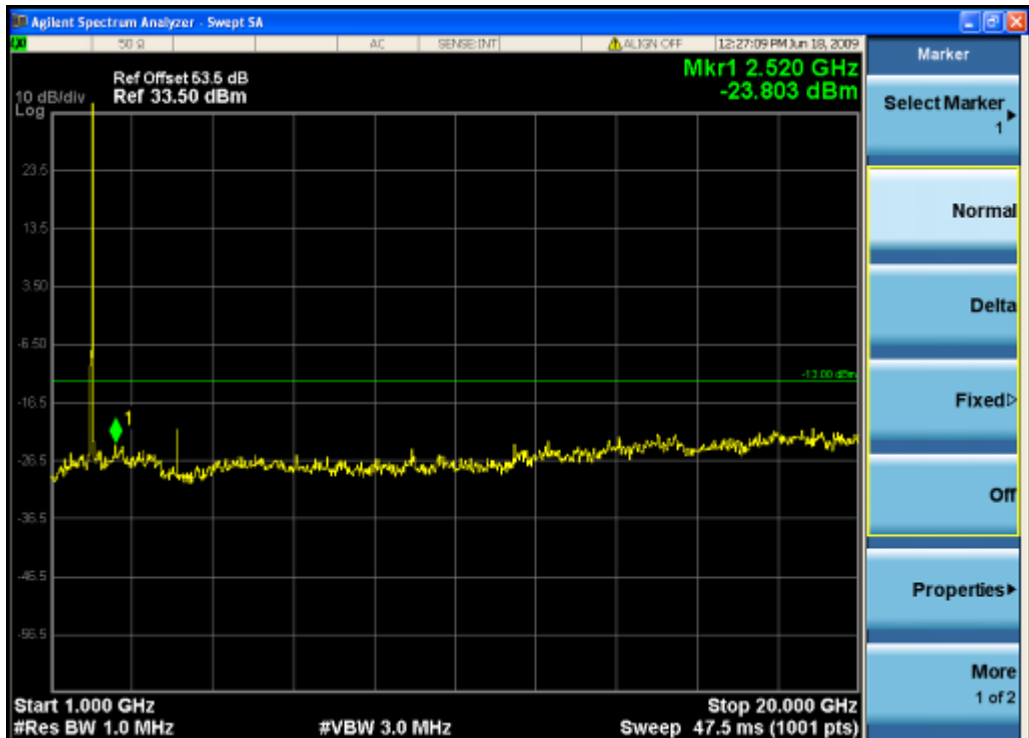

SGS-CSTC Standards Technical Services Co., Ltd.

Report No.: GLEMO09060172301

Page: 45 of 113

FCC ID: PX8TS-71-12XXXXXX

PCS Band

PCS—WCDMA down link(lowest frequency)

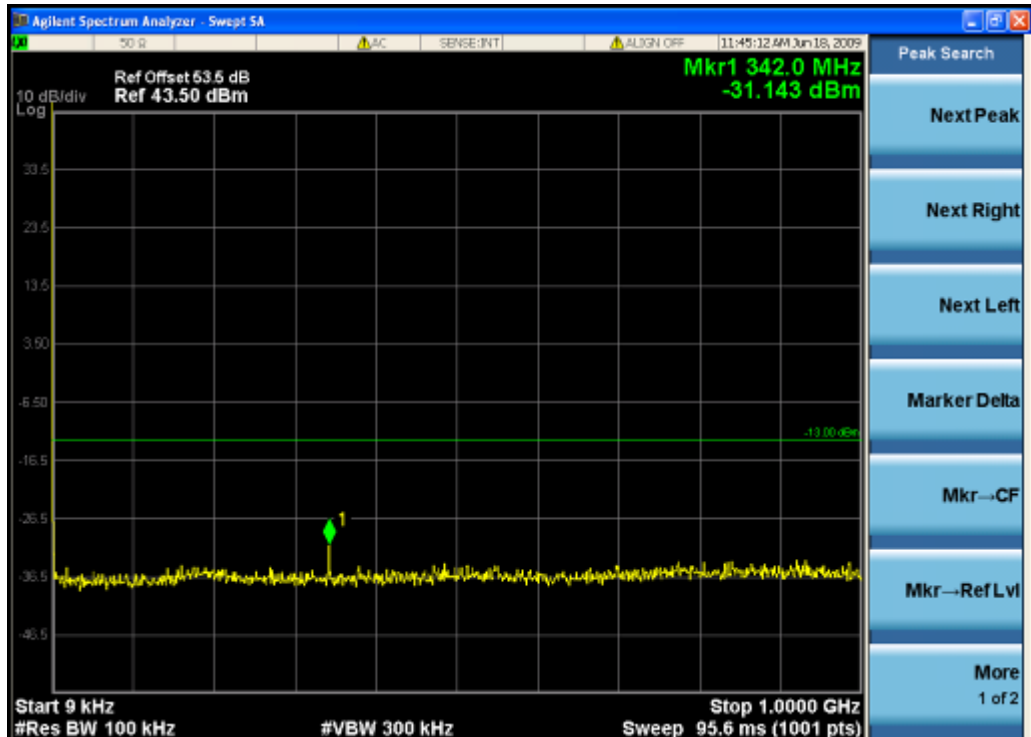

PCS—WCDMA down link(lowest frequency)



SGS-CSTC Standards Technical Services Co., Ltd.

Report No.: GLEMO09060172301

Page: 46 of 113

FCC ID: PX8TS-71-12XXXXXX

PCS—WCDMA down link(middle frequency)

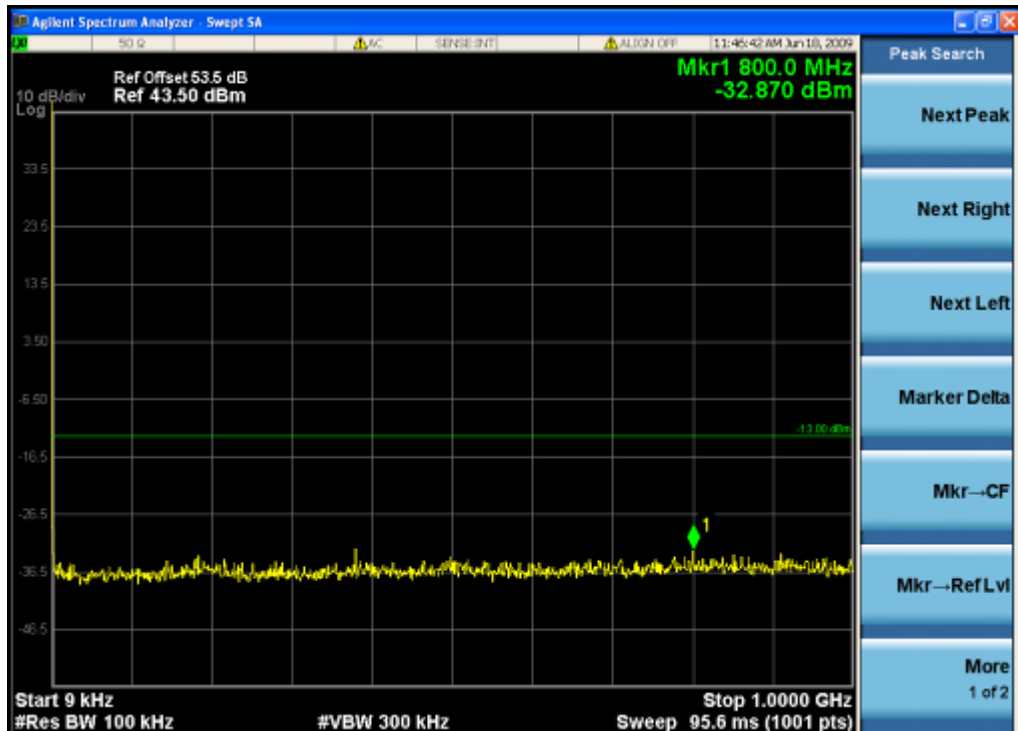

PCS—WCDMA down link(middle frequency)

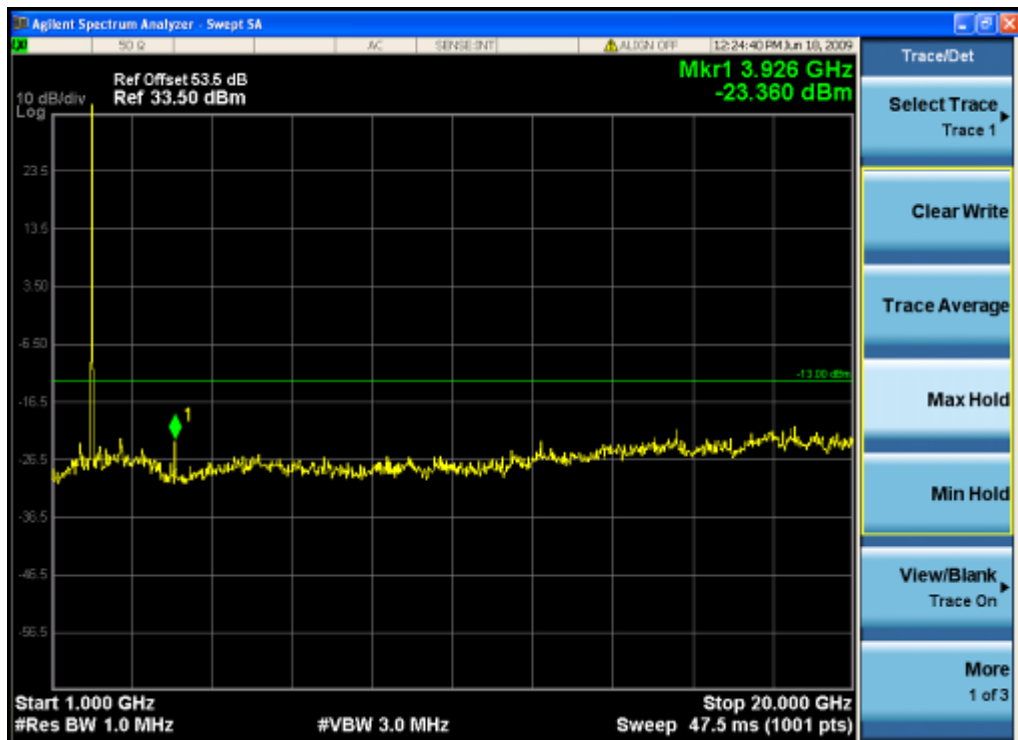

SGS-CSTC Standards Technical Services Co., Ltd.

Report No.: GLEMO09060172301

Page: 47 of 113

FCC ID: PX8TS-71-12XXXXXX

PCS—WCDMA down link(highest frequency)

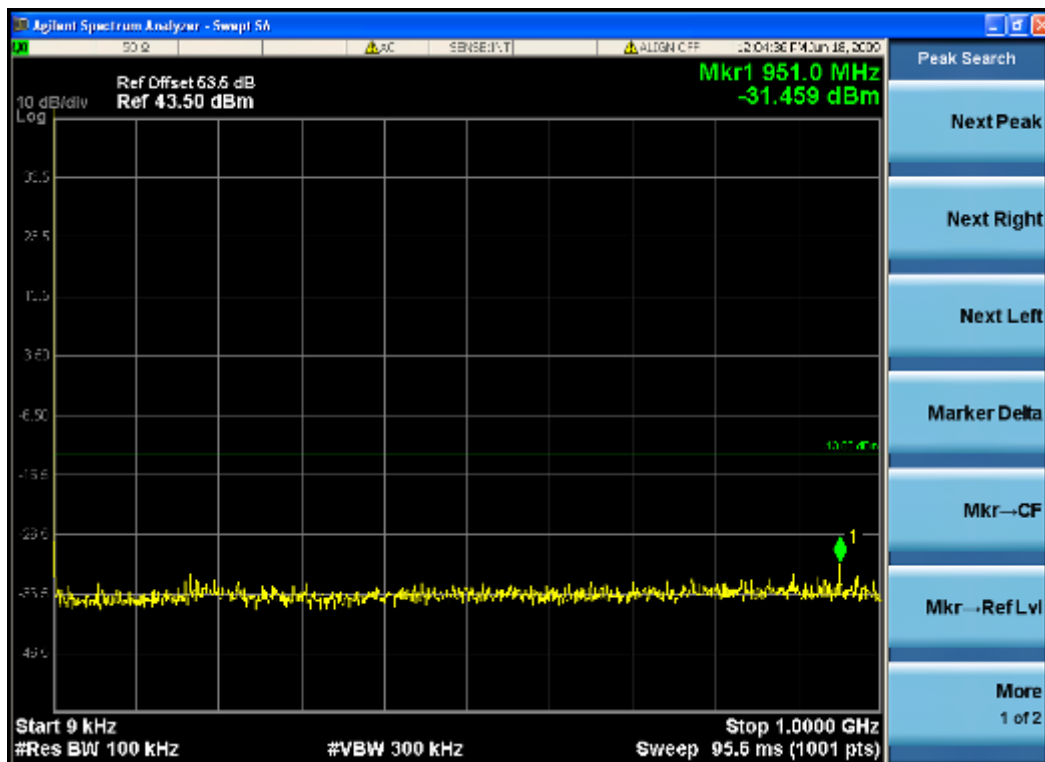

PCS—WCDMA down link(highest frequency)



7.2.3 Band Edge & Intermodulation

Test Date: 17 to 19 June 2009

Test Requirement: FCC part 22.917(b) & FCC part 24.238(b)

§22.917 Emission limitations for cellular equipment.

(b) Measurement procedure. Compliance with these rules is based on the use of measurement instrumentation employing a resolution bandwidth of 100 kHz or greater. In the 1 MHz bands immediately outside and adjacent to the frequency block a resolution bandwidth of at least one percent of the emission bandwidth of the fundamental emission of the transmitter may be employed. A narrower resolution bandwidth is permitted in all cases to improve measurement accuracy provided the measured power is integrated over the full required measurement bandwidth (i.e. 100 kHz or 1 percent of emission bandwidth, as specified). The emission bandwidth is defined as the width of the signal between two points, one below the carrier center frequency and one above the carrier center frequency, outside of which all emissions are attenuated at least 26 dB below the transmitter power.

§24.238 Emission limitations for Broadband PCS equipment

(b) Measurement procedure. Compliance with these rules is based on the use of measurement instrumentation employing a resolution bandwidth of 1 MHz or greater. However, in the 1 MHz bands immediately outside and adjacent to the frequency block a resolution bandwidth of at least one percent of the emission bandwidth of the fundamental emission of the transmitter may be employed. A narrower resolution bandwidth is permitted in all cases to improve measurement accuracy provided the measured power is integrated over the full required measurement bandwidth (i.e. 1 MHz or 1 percent of emission bandwidth, as specified). The emission bandwidth is defined as the width of the signal between two points, one below the carrier center frequency and one above the carrier center frequency, outside of which all emissions are attenuated at least 26 dB below the transmitter power.

Test Method: FCC part 2.1051&2-11-04/EAB/RF

Test Configuration:

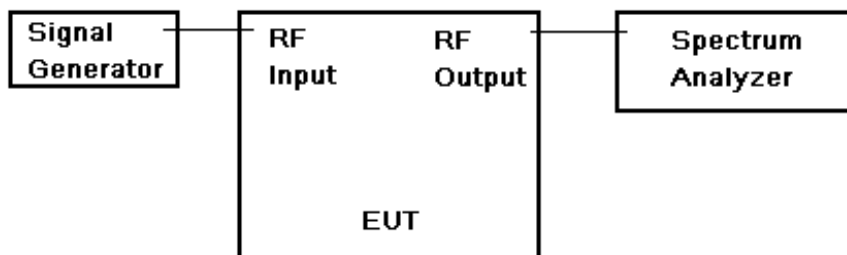

Fig.3. Band edge and Intermodulation test configuration

EUT Operation:

Status: The output power of EUT be set to maximum value.

Conditions: Normal conditions

Application: Cellular Band RF output ports, PCS Band RF output ports

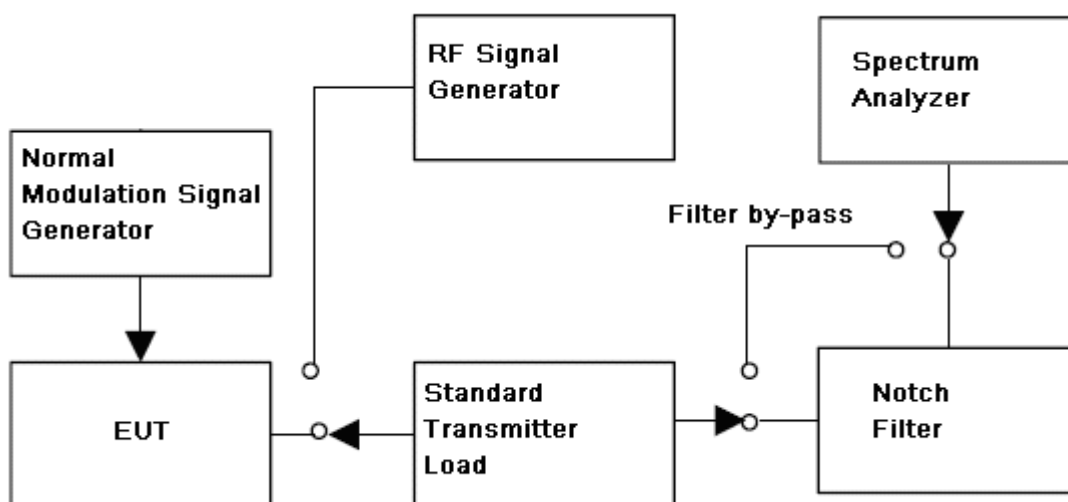

Test Procedure:

Conducted Emissions test procedure:

- a) Connect the equipment as illustrated, with the notch filter by-passed, when the output power is over the max value of the Spectrum Analyzer, add the attenuator to avoid destroying the facility.
- b) Set the center frequency of the spectrum analyzer to the assigned transmitter frequency, key the transmitter, and set the level of the carrier to the full scale reference line.
- c) do not apply any tone to modulate the EUT.
- d) Adjust the spectrum analyzer for the following settings:
 - 1) Resolution Bandwidth,(base the standard, apply the different set),here is 100KHz for frequency band less than 1GHz, 1MHz for frequency over 1GHz;
 - 2) Video Bandwidth refer to standard requirement.
- e) Adjust the center frequency of the spectrum analyzer for incremental coverage of the range from:
 - 1) the lowest radio frequency generated in the equipment, it can be 9KHz base the test method, here select 30MHz as lowest frequency start point;
 - 2) the highest radion frequency shall higher than 10 times of carrier frequency;
- f) Record the frequencies and levels of spurious emissions from step e)

Remark:

The notch filter is used for avoid the EUT fundamental carrier output power making the spectrum overload and the harmonic spurious brought by it.

When the EUT fundamental carrier is not enough to make the status, the notch filter could be not used.

SGS-CSTC Standards Technical Services Co., Ltd.

Report No.: GLEMO09060172301

Page: 50 of 113

FCC ID: PX8TS-71-12XXXXXX

Intermodulation

Test Procedure:

1. Connect the equipment as illustrated;
2. Test the background noise level with all the test facilities;
3. Keep one transmitting path, all other connectors shall be connected by normal power or RF leads;
4. Select the attenuator to avoid the test receiver or spectrum analyzer being destroyed;
5. Keep the EUT continuously transmitting in max power;
6. Keep two signals are same in modulation type and level;
7. Measure the 3 order intermodulated product by the EUT(the sum of the two unwanted signal should be rated power);
6. Correct for all losses in the RF path;
7. Read the conducted spurious emissions of the EUT antenna port.
 - CW signal rather than typical signal is acceptable (for FM).
 - At maximum drive level, for each modulation: one test with three tones, or two tests (high-, low-band edge) with two tones
 - Limit usually is -13dBm conducted.
 - Not needed for Single Channel systems.
 - Combination of modulation types not needed.

7.2.3.1 Measurement Record:

Cellular Band

Cellular—TDMA one signal input down link— Lower Edge

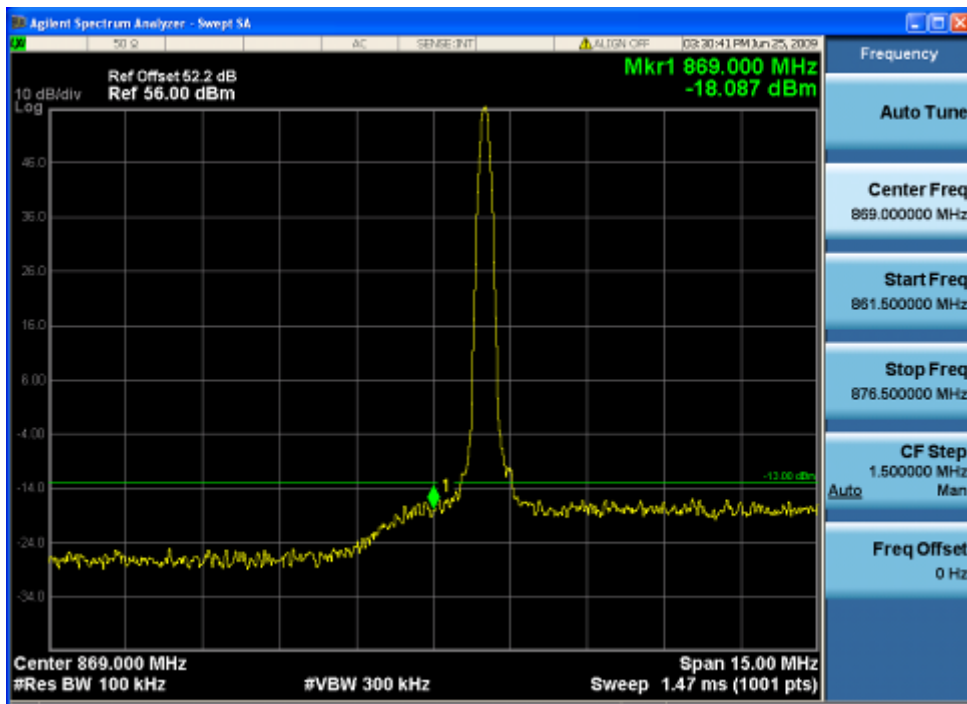

Cellular—TDMA one signal input down link— Upper Edge

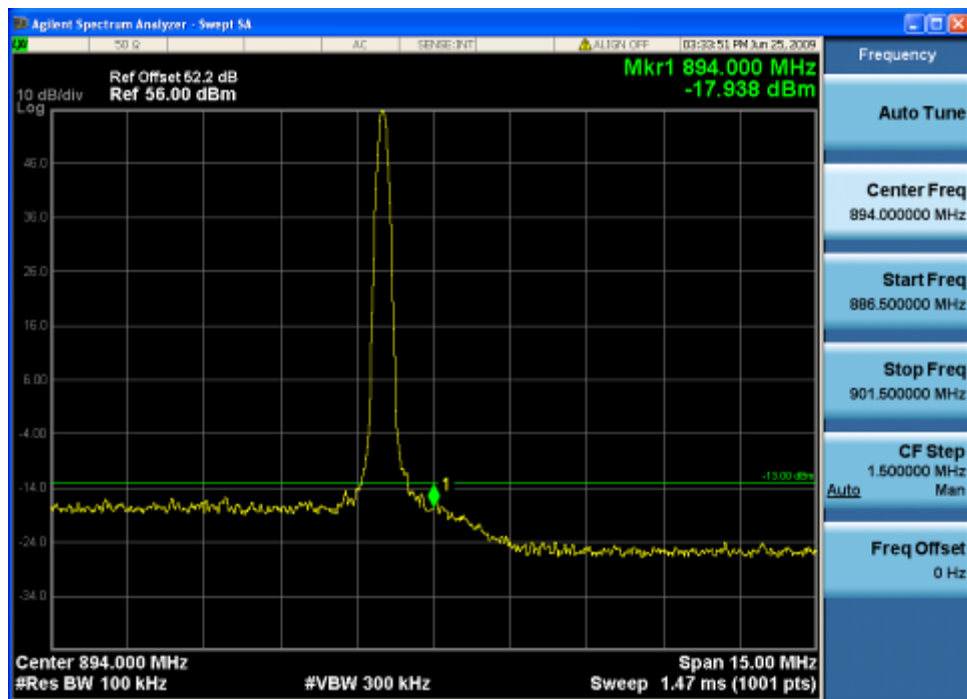

Cellular—TDMA two signal input down link—Lower Edge

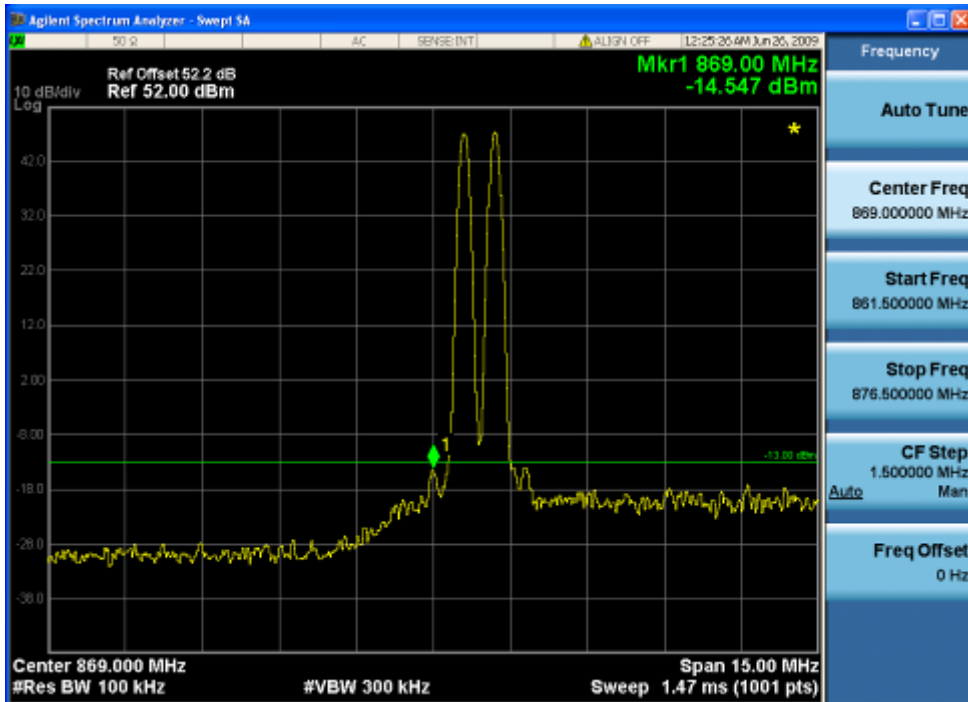

Cellular—TDMA two signal input down link—Upper Edge

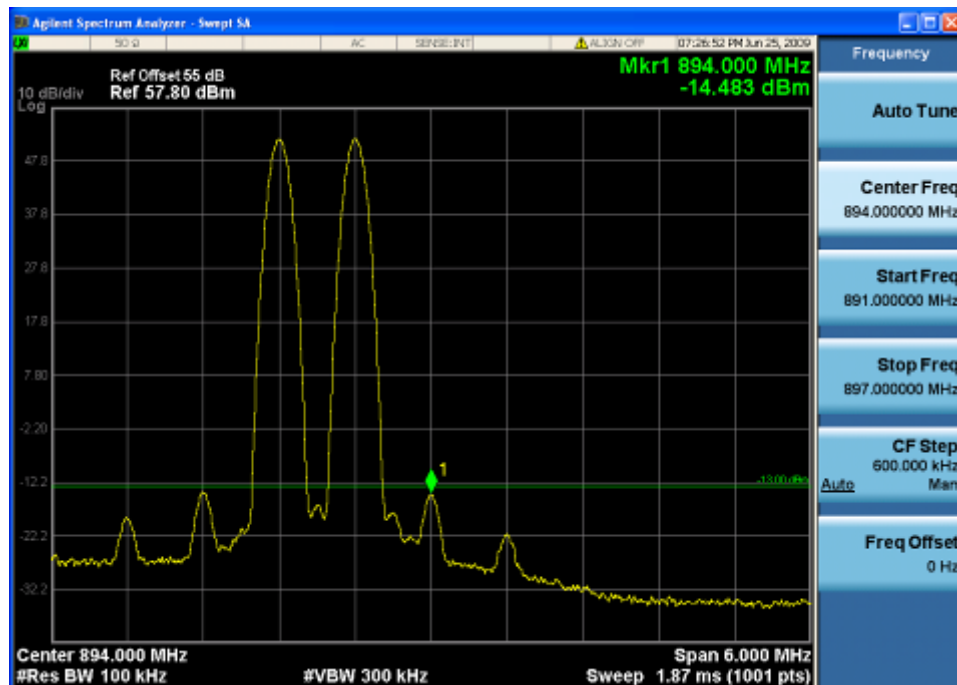

SGS-CSTC Standards Technical Services Co., Ltd.

Report No.: GLEMO09060172301

Page: 53 of 113

FCC ID: PX8TS-71-12XXXXXX

Cellular Band

Cellular—GSM one signal input down link— Lower Edge

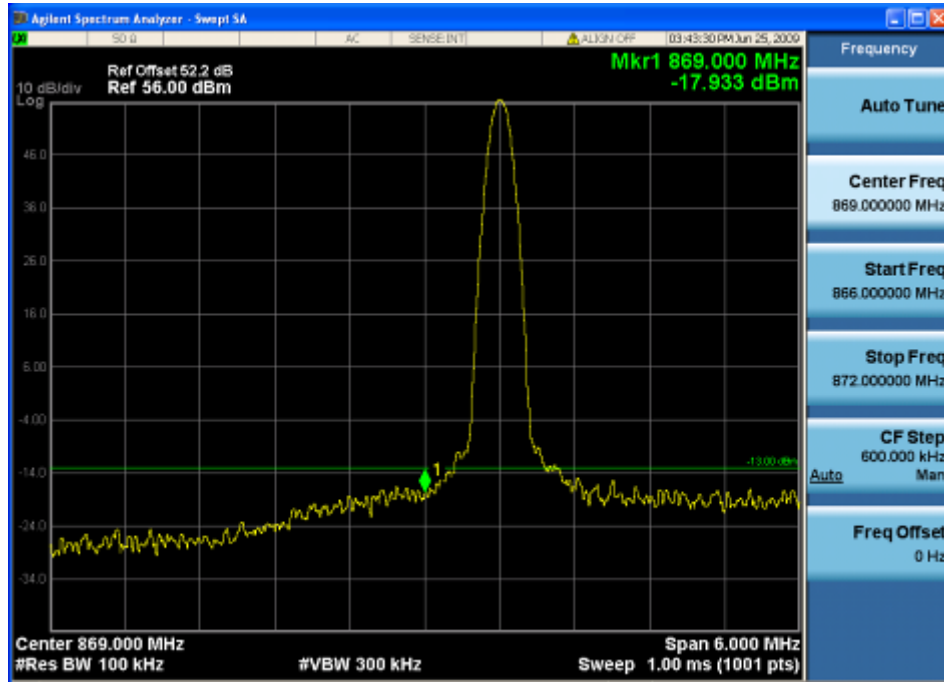

Cellular—GSM one signal input down link— Upper Edge

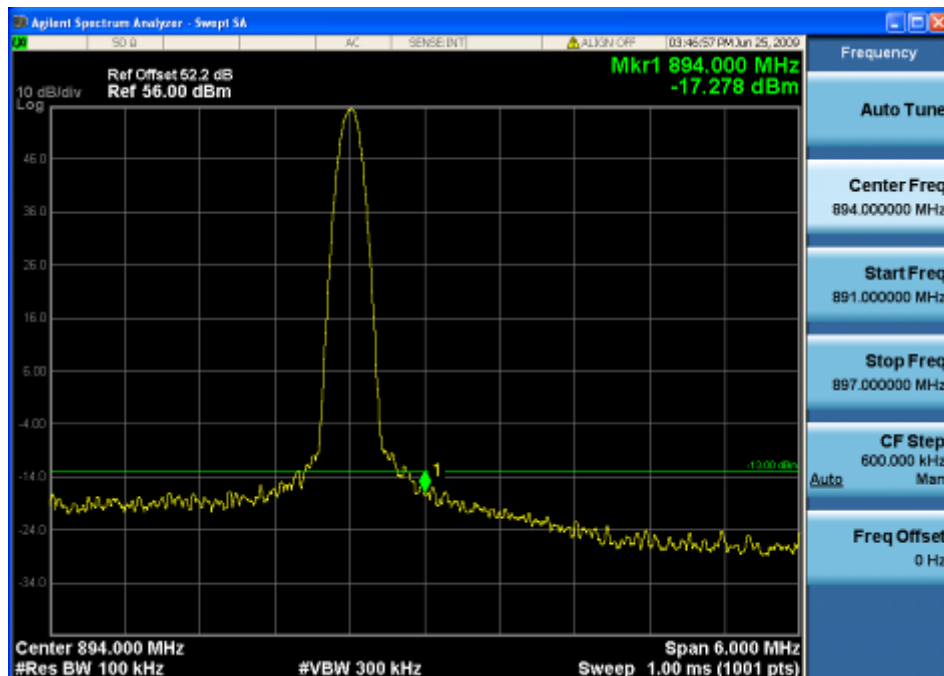

SGS-CSTC Standards Technical Services Co., Ltd.

Report No.: GLEMO09060172301

Page: 54 of 113

FCC ID: PX8TS-71-12XXXXXX

Cellular—GSM two signal input down link—Lower Edge

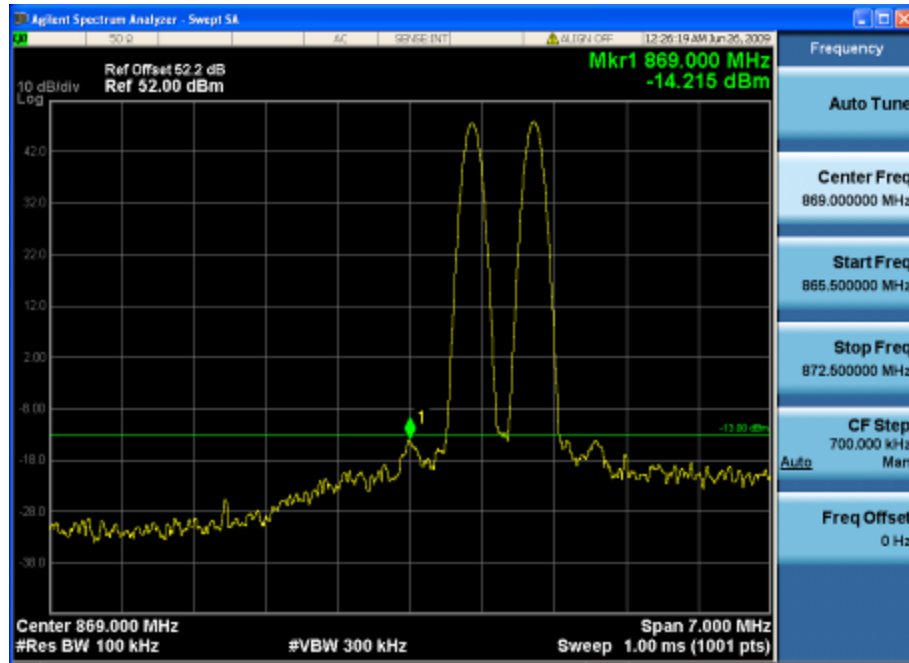

Cellular—GSM two signal input down link—Upper Edge

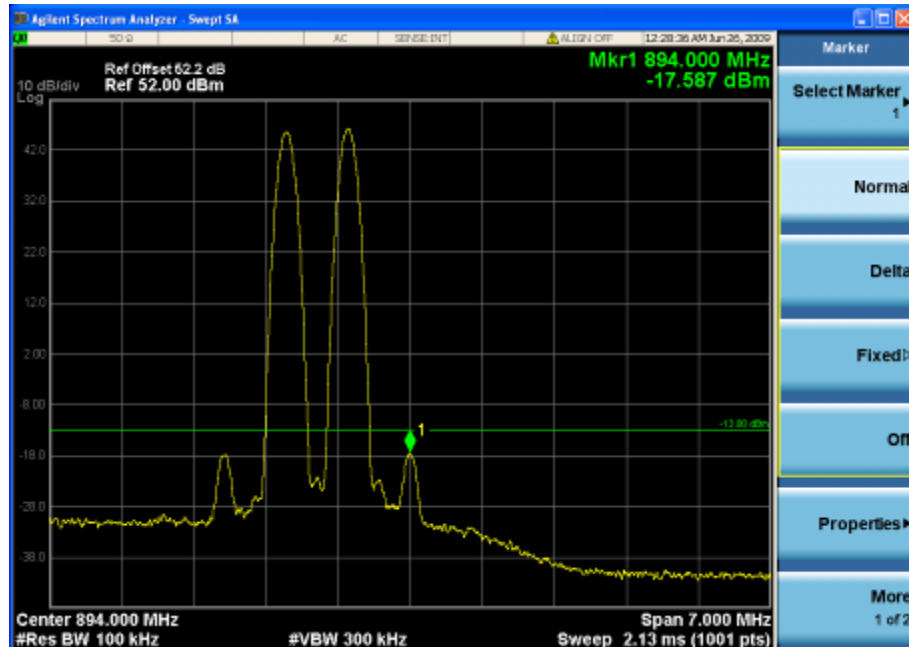

SGS-CSTC Standards Technical Services Co., Ltd.

Report No.: GLEMO09060172301

Page: 55 of 113

FCC ID: PX8TS-71-12XXXXXX

Cellular Band

Cellular—EDGE one signal input down link— Lower Edge

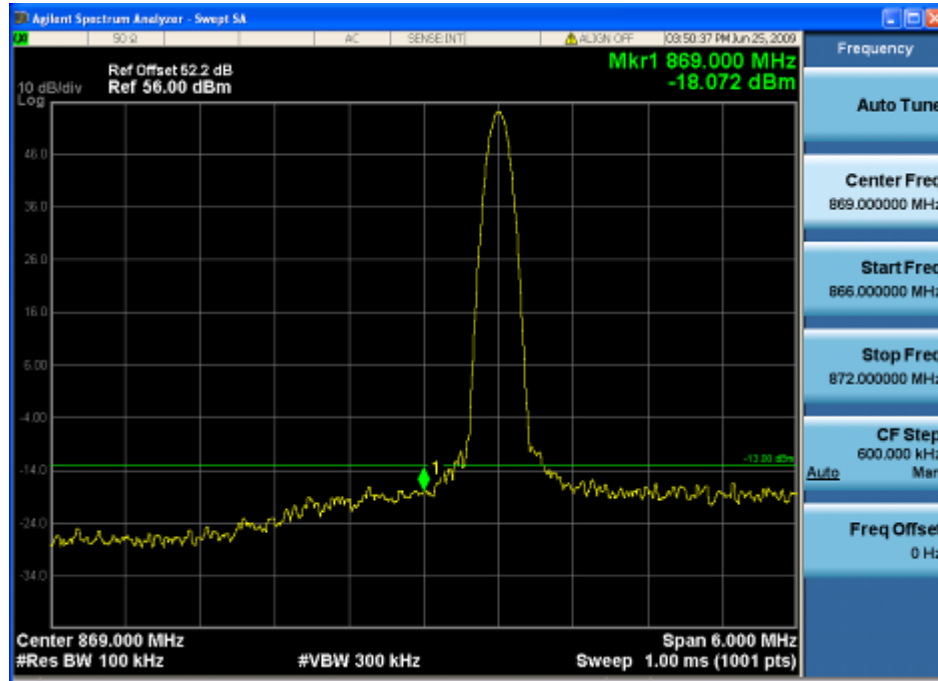

Cellular—EDGE one signal input down link— Upper Edge

