



198 Kezhu Road, Sciencetech Park, Guangzhou Economic & Technology Development District, Guangzhou, China 510663

Tel: +86 20 82155555 Fax: +86 20 82075059

Email: [sgs\\_internet\\_operations@sgs.com](mailto:sgs_internet_operations@sgs.com)

FEDERAL COMMUNICATIONS COMMISSION

Registration number: 282399

Report No.: GLEMO09060172201

Page: 1 of 89

FCC ID: PX8TS-19-12XXXXXX

## TEST REPORT

|                                   |  |
|-----------------------------------|--|
| Application No.:                  | GLEMO090601722RF   |
| Applicant:                        | Comba telecom limited  |
| FCC ID:                           | PX8TS-19-12XXXXXX  |
| Frequency Band:                   | 1930MHz to 1990MHz   |
| <b>Equipment under Test (EUT)</b> |  |
| Name:                             | 1900MHz Tower Bottom System  |
| Model No.:                        | TS-19-1203354A, TS-19-1202351A, TS-19-1201351A, TS-19-1203154A ♣   |
| ♣                                 | Please refer to section 3 of this report which indicates which item was actually tested and which were electrically identical. |
| Standards:                        | FCC part 24E, FCC part 15B   |
| Date of Issue:                    | July 30, 2009  |
| Test Result :                     | <b>PASS *</b>  |

\* In the configuration tested, the EUT detailed in this report complied with the standards specified above. Please refer to section 3 of this report for further details.

Authorized Signature:

Stephen Guo  
Lab Manager

The manufacturer should ensure that all products in series production are in conformity with the product sample detailed in this report. If the product in this report is used in any configuration other than that detailed in the report, the manufacturer must ensure the new system complies with all relevant standards.

The report must not be used by the client to claim product certification, approval, or endorsement by NVLAP, NIST, or any agency of the federal government. All test results in this report can be traceable to National or International Standards.

This document is issued by the Company subject to its General Conditions of Service printed overleaf, available on request or accessible at [www.sgs.com/terms\\_and\\_conditions.htm](http://www.sgs.com/terms_and_conditions.htm) and, for electronic format documents, subject to Terms and Conditions for Electronic Documents at [www.sgs.com/terms\\_e-document.htm](http://www.sgs.com/terms_e-document.htm). Attention is drawn to the limitation of liability, indemnification and jurisdiction issues defined therein. Any holder of this document is advised that information contained hereon reflects the Company's findings at the time of its intervention only and within the limits of Client's instructions, if any. The Company's sole responsibility is to its Client and this document does not exonerate parties to a transaction from exercising all their rights and obligations under the transaction documents. This document cannot be reproduced except in full, without prior written approval of the Company. Any unauthorized alteration, forgery or falsification of the content or appearance of this document is unlawful and offenders may be prosecuted to the fullest extent of the law. Unless otherwise stated the results shown in this test report refer only to the sample(s) tested and such sample(s) are retained for 90 days only



**SGS-CSTC Standards Technical Services Co., Ltd.**

Report No.: GLEMO09060172201

Page: 2 of 89

FCC ID: PX8TS-19-12XXXXXX

**2 Version**

| <b>Version No.</b> | <b>Date</b>   | <b>Description</b>    |
|--------------------|---------------|-----------------------|
| 00                 | July 03, 2009 | Original              |
| 01                 | July 16,2009  | Add the N+1 test data |
| 02                 | July 30,2009  | Add FCC part 15 data  |
|                    |               |                       |

**Prepared By:** Jeffrey Chen **Date** 2009-7-30  
**Project Engineer**

**Check By:** Gavin Wu **Date** 2009-7-30  
**Reviewer**



### 3 Test Summary

| Test Item                          | Test Requirement                | Test Method                       | Result |
|------------------------------------|---------------------------------|-----------------------------------|--------|
| Output Power                       | FCC part 24.232                 | FCC part 2.1046<br>2-11-04/EAB/RF | PASS   |
| Conducted Spurious Emissions       | FCC part 24.238                 | FCC part 2.1051<br>2-11-04/EAB/RF | PASS   |
| Band Edge & Intermodulation        | FCC part 24.238                 | FCC part 2.1051<br>2-11-04/EAB/RF | PASS   |
| Radiated Spurious Emissions        | FCC part 24.238                 | FCC part 2.1053<br>2-11-04/EAB/RF | PASS   |
| Occupied Bandwidth                 | 2-11-04/EAB/RF                  | FCC part 2.1049<br>2-11-04/EAB/RF | PASS   |
| Out of Band Rejection              | 2-11-04/EAB/RF                  | 2-11-04/EAB/RF                    | PASS   |
| Frequency Stability                | FCC part 24.235                 | FCC part 2.1055                   | PASS   |
| Radiated Emission (30MHz to 10GHz) | FCC PART 15,<br>SUBPART B: 2008 | ANSI C63.4:2003                   | PASS   |

Remark:

Tx: In this whole report Tx (or tx) means Transmitter.

Rx: In this whole report Rx (or rx) means Receiver.

♣ Model No: TS-19-1203354A, TS-19-1202351A, TS-19-1201351A, TS-19-1203154A

The equipment configuration as below:

Model No: TS-19-1203354A

Configuration 9 - 1900 MHz, 4x2, 3 sector  
TS-19-1203354A

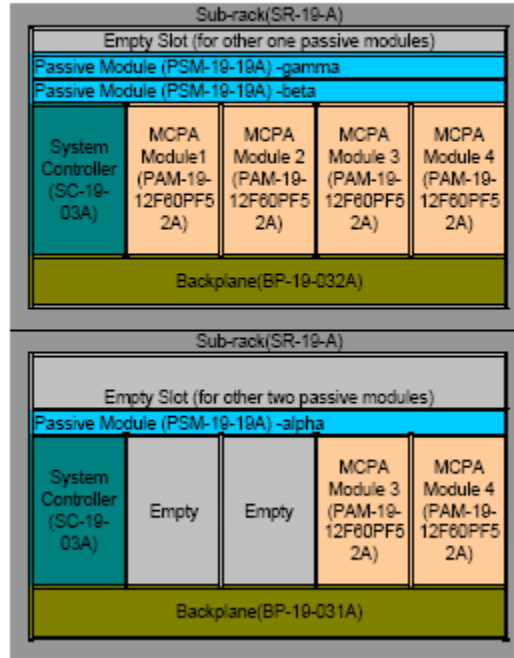

Model No: TS-19-1202351A

Configuration 7 - 1900 MHz, N+1, 3 sector  
TS-19-1202351A

Difference between TS-19-1203354A is:

- Without 2x1 combiner, each sector of TS-19-1202351A has only one MCPA and 51dBm output power which is half of TS-19-1203354A.
- TS-19-1202351A has a redundant MCPA which can be put into operation for fault MCPA via N+1 switch on the backplane.

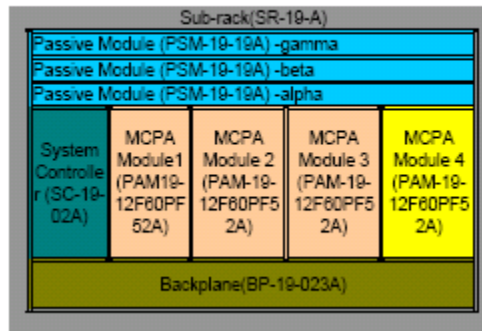

Model No: TS-19-1201351A

Configuration 8 - 1900 MHz, 4in4out, 3 sector  
TS-19-1201351A

Difference between TS-19-1203354A is:

- Without 2x1 combiner, each sector of TS-19-1201351A has only one MCPA and 51dBm output power which is half of TS-19-1203354A.
- In TS-19-1201351A, there are no switch function blocks like 2x1 combiner switch or N+1 redundant switch. One MCPA

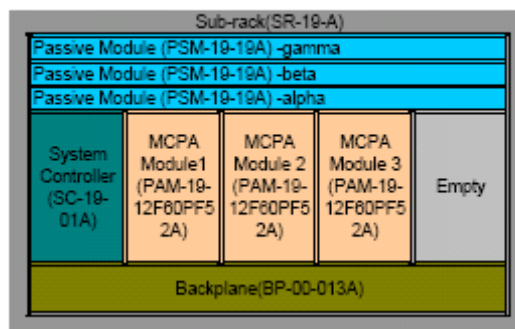

per each sector is assigned and directly connected to Passive module.

Model No: TS-19-1203154A

Difference between TS-19-1203354A is:

TS-19-1203154A can only be used for one sector.

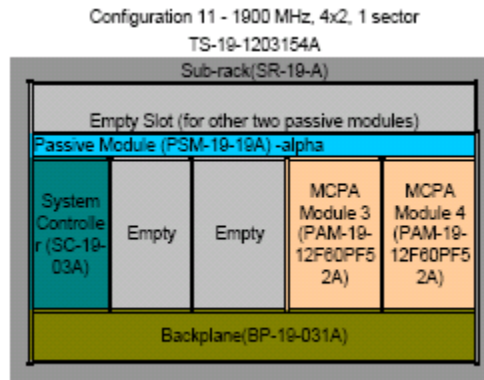

There were input duplexer/combiner ,input switch , output switch ,output duplexer/combiner and MCPA module between the RF input ports and RF output ports, all the radio link way were adjusted by the controller with the software.



## 4 Contents

|   | Page  |
|---|-------|
| 1 COVER PAGE .....                                    | 1     |
| 2 VERSION .....                                       | 2     |
| 3 TEST SUMMARY .....                                  | 3     |
| 4 CONTENTS .....                                      | 6     |
| 5 GENERAL INFORMATION .....                           | 7     |
| 5.1 CLIENT INFORMATION .....                          | 7     |
| 5.2 GENERAL DESCRIPTION OF E.U.T. ....                | 7     |
| 5.3 DESCRIPTION OF EUT OPERATION .....                | 7     |
| 5.4 STANDARDS APPLICABLE FOR TESTING .....            | 7     |
| 5.5 TEST LOCATION .....                               | 7     |
| 5.6 OTHER INFORMATION REQUESTED BY THE CUSTOMER ..... | 8     |
| 5.7 TEST FACILITY .....                               | 8     |
| 6 EQUIPMENTS USED DURING TEST .....                   | 9     |
| 7 TEST RESULT .....                                   | 11    |
| 7.1 E.U.T. OPERATION .....                            | 11    |
| 7.2 TEST PROCEDURE & MEASUREMENT DATA .....           | 13    |
| 7.2.1 RF Output Power .....                           | 14    |
| 7.2.2 Conducted Spurious Emissions .....              | 17    |
| 7.2.3 Band Edge & Intermodulation .....               | 34    |
| 7.2.4 Radiated Spurious Emissions .....               | 48    |
| 7.2.5 Occupied Bandwidth .....                        | 53    |
| 7.2.6 Out of Band Rejection .....                     | 84    |
| 7.2.7 Frequency Stability .....                       | 86    |
| 7.2.8 Radiated Emissions, 30MHz to 10GHz .....        | 87-89 |



## 5 General Information

### 5.1 Client Information

Applicant Name: Comba telecom limited  
Applicant Address: 611 East Wing, No. 8 Science Park West Avenue, Hong Kong Science Park, Tai Po, Hong Kong

### 5.2 General Description of E.U.T.

Name: 1900MHz Tower Bottom System  
Model No.: TS-19-1203354A(4x2 3 sector), TS-19-1202351A(N+1),  
TS-19-1201351A(4 in 4 out), TS-19-1203154A (4x2 1sector)  
Power Supply: 27V DC  
Adaptor: N/A

### 5.3 Description of EUT operation

Type of Modulation TDMA,GSM,EDGE,CDMA,WCDMA  
Emission Designator: DXW(TDMA),F9W(CDMA),  
GXW (GSM),GXW (EDGE),GXW (WCDMA)  
Frequency Band: PCS Band  
(1930MHz to 1990MHz downlink)  
Norminal Power Output: 54dBm(4x2 system)  
51dBm(N+1,4 in 4 out system)  
Antenna Type N/A

### 5.4 Standards Applicable for Testing

The standard used was FCC part 2 & FCC part 24 & FCC part 15B.

### 5.5 Test Location

All tests were performed at:

SGS-CSTC Standards Technical Services Co., Ltd., Guangzhou EMC Laboratory,  
198 Kezhu Road, Sciencetech Park, Guangzhou Economic & Technology Development District,  
Guangzhou, Guangdong, China 510663

Tel: +86 20 82155555 Fax: +86 20 82075059

No tests were sub-contracted.



## **5.6 Other Information Requested by the Customer**

None.

## **5.7 Test Facility**

The test facility is recognized, certified, or accredited by the following organizations:

- **NVLAP – Lab Code: 200611-0**

SGS-CSTC Standards Technical Services Co., Ltd., Guangzhou EMC Laboratory is recognized under the National Voluntary Laboratory Accreditation Program (NVLAP/NIST). NVLAP Code: 200611-0.

- **FCC – Registration No.: 282399**

SGS-CSTC Standards Technical Services Co., Ltd., EMC Laboratory has been registered and fully described in a report filed with the (FCC) Federal Communications Commission. The acceptance letter from the FCC is maintained in our files. Registration 282399, May 31, 2002. With the above and NVLAP's accreditation, SGS-CSTC is an authorized test laboratory for the DoC process.





## 6 Equipments Used during Test

| RE in Chamber |                               |                   |               |            |                      |                         |
|---------------|-------------------------------|-------------------|---------------|------------|----------------------|-------------------------|
| No:           | Test Equipment                | Manufacturer      | Model No.     | Serial No. | Cal. Date (dd-mm-yy) | Cal.Due date (dd-mm-yy) |
| EMC0525       | Compact Semi-Anechoic Chamber | ChangZhou ZhongYu | N/A           | N/A        | N/A                  | N/A                     |
| EMC0522       | EMI Test Receiver             | Rohde & Schwarz   | ESIB26        | 100249     | 28-01-2008           | 28-01-2009              |
| N/A           | EMI Test Software             | Audix             | E3            | N/A        | N/A                  | N/A                     |
| EMC0514       | Coaxial cable                 | SGS               | N/A           | N/A        | 04-12-2007           | 04-12-2008              |
| EMC0524       | Bi-log Type Antenna           | Schaffner -Chase  | CBL6112B      | 2966       | 12-08-2008           | 12-08-2009              |
| EMC0519       | Bilog Type Antenna            | Schaffner -Chase  | CBL6143       | 5070       | 12-08-2008           | 12-08-2009              |
| EMC0517       | Horn Antenna                  | Rohde & Schwarz   | HF906         | 100095     | 12-08-2008           | 12-08-2009              |
| EMC0040       | Spectrum Analyzer             | Rohde & Schwarz   | FSP30         | 100324     | 05-12-2008           | 05-12-2009              |
| EMC0520       | 0.1-1300 MHz Pre-Amplifier    | HP                | 8447D OPT 010 | 2944A06252 | 11-03-2008           | 11-03-2009              |
| EMC0521       | 1-26.5 GHz Pre-Amplifier      | Agilent           | 8449B         | 3008A01649 | 11-03-2008           | 11-03-2009              |
| EMC0075       | 310N Amplifier                | Sonama            | 310N          | 272683     | 10-09-2008           | 10-09-2009              |
| EMC0523       | Active Loop Antenna           | EMCO              | 6502          | 00042963   | 09-08-2008           | 09-08-2010              |
| EMC0530       | 10m Semi- Anechoic Chamber    | ETS               | N/A           | N/A        | 10-08-2008           | 10-08-2009              |

| Conducted Emission |                   |                                    |                            |              |                      |                         |
|--------------------|-------------------|------------------------------------|----------------------------|--------------|----------------------|-------------------------|
| No:                | Test Equipment    | Manufacturer                       | Model No.                  | Serial No.   | Cal. Date (dd-mm-yy) | Cal.Due date (dd-mm-yy) |
| EMC0306            | Shielding Room    | Zhong Yu                           | 8 x 3 x 3.8 m <sup>3</sup> | N/A          | N/A                  | N/A                     |
| EMC0102            | LISN              | Schaffner Chase                    | MNZ050D/1                  | 1421         | 14-12-2008           | 14-12-2009              |
| EMC0118            | Two-line v-netwok | Rohde & Schwarz                    | ENV216                     | 3560.6550.02 | 28-07-2008           | 28-07-2009              |
| EMC0506            | EMI Test Receiver | Rohde & Schwarz                    | ESCS30                     | 100085       | 14-12-2008           | 14-12-2009              |
| EMC0107            | Coaxial Cable     | SGS                                | 2m                         | N/A          | 26-11-2008           | 26-11-2009              |
| EMC0106            | Voltage Probe     | SGS                                | N/A                        | N/A          | N/A                  | N/A                     |
| EMC0120            | 8 Line ISN        | Fischer Custom Communications Inc. | FCC-TLISN-T8-02            | 20550        | 21-02-2009           | 21-02-2010              |
| EMC0121            | 4 Line ISN        | Fischer Custom Communications Inc. | FCC-TLISN-T4-02            | 20549        | 21-02-2009           | 21-02-2010              |
| EMC0122            | 2 Line ISN        | Fischer Custom Communications Inc. | FCC-TLISN-T2-02            | 20548        | 21-02-2009           | 21-02-2010              |

| General used equipment |                |              |           |            |                      |                         |
|------------------------|----------------|--------------|-----------|------------|----------------------|-------------------------|
| No:                    | Test Equipment | Manufacturer | Model No. | Serial No. | Cal. Date (dd-mm-yy) | Cal.Due date (dd-mm-yy) |
| EMC0006                | DMM            | Fluke        | 73        | 70681569   | 23-12-2008           | 23-12-2009              |
| EMC0007                | DMM            | Fluke        | 73        | 70671122   | 23-12-2008           | 23-12-2009              |



# SGS-CSTC Standards Technical Services Co., Ltd.

Report No.: GLEMO09060172201

Page: 10 of 89

FCC ID: PX8TS-19-12XXXXXX

| Other equipment |                   |               |           |            |                         |                             |
|-----------------|-------------------|---------------|-----------|------------|-------------------------|-----------------------------|
| No:             | Test Equipment    | Manufacturer  | Model No. | Serial No. | Cal. Date<br>(dd-mm-yy) | Cal. Due Date<br>(dd-mm-yy) |
| NA              | Power Meter       | Agilent       | E4419B    | MY45100856 | 2009.6.12               | 2010.6.11                   |
| NA              | Signal Generator  | Agilent       | E4437B    | US39260800 | 2009.6.17               | 2010.6.16                   |
| NA              | Signal Generator  | Agilent       | E4438C    | US39260800 | 2009.6.14               | 2010.6.14                   |
| NA              | Spectrum Analyzer | Agilent       | N9020A    | MY48011385 | 2008.7.31               | 2009.7.30                   |
| NA              | Signal Generator  | Rohde&Schwarz | SMU 200A  | 103303     | 2009.6.10               | 2010.6.09                   |

| No: | Name.            | Manufacturer. | Model No. | Serial No.  | Cal. Date<br>(dd-mm-yy) | Cal. Due Date<br>(dd-mm-yy) |
|-----|------------------|---------------|-----------|-------------|-------------------------|-----------------------------|
| NA  | Amplifier driver | Comba telecom | PA-1900   | S/N:0905025 | /                       | /                           |



## 7 Test Result

### 7.1 E.U.T. Operation

|                        |              |
|------------------------|--------------|
| Input voltage:         | 27V DC       |
| Operating Environment: |              |
| Temperature:           | 22°C ~26°C   |
| Humidity:              | 46%~56% RH   |
| Atmospheric Pressure:  | 990~1005mbar |
| Test Requirement:      |              |

#### FIBER-OPTIC AND OTHER SIMILAR RF DISTRIBUTION SYSTEMS

Fiber-optic distribution systems are a type of in-building radiation system that receives RF signals from an antenna, distributes the signal over fiber-optic cable, and then retransmits at another location for example within a building or tunnel. Most fiber-optic systems are signal boosters; however, some may be repeaters. These systems generally have two enclosures typically called host (or local or donor unit) and remote. Some systems may also have an optional expander box for fan-out to multiple remotes. The system transmits downlink signals from the remote unit to handsets, portables, or clients, and transmits uplink signals via from the host unit. Usually but not always the uplink goes through an intermediate amplifier to a “donor” antenna. Therefore both uplink and downlink must be tested, unless filing effectively documents how connection of uplink to donor antenna with or without an intermediate amplifier will be prevented, such as for always only a cabled connection to a base station. Fiber-optic systems are not amplifiers (AMP equipment class) – they are equipment class TNB or PCB. The same approval procedures also apply for multiple-enclosure systems connected by coax cable.

*Synonyms and related terms: in-building radiation system, coverage enhancer, distributed antenna system, fiber-optic distribution system, converter, donor anten*

Typical in-building or distributed antenna systems can consist of five different components (enclosures), not counting antennas:

#### 1) **host unit**

- a) transmits uplink to base station via antenna thru coax, **passive interface unit**, or **active interface unit** (amplifier)
- b) sends base-station downlink via fiber-optic or coax to **remote**
- c) receives handset uplink via fiber-optic or coax from **remote**
- d) optional connection to **expansion unit** via fiber-optic
- e) separate FCC ID from **remote**, unless electrically identical
- f) **non-transmitting host unit**
- i) connects directly to a base station via coax cable but does not connect to antenna or amplifier
- ii) Part 15 digital device subject to Verification, no FCC ID

#### 2) **remote unit**

- a) receives base-station downlink via fiber-optic or coax from **host**, transmits via antenna to handsets
- b) returns handset uplink via fiber-optic or coax to **host**
- c) separate FCC ID from **remote**, unless electrically identical



**3) expansion unit**

- a) fiber-optic or coax from **host**
- b) fiber-optic or coax fan-out to **remote(s)**
- c) Part 15 digital device subject to Verification, no FCC ID

**4) passive interface unit**

- a) contains attenuators, splitters, combiners
- b) coax cable connection between **host** and base-station
- c) passive device, no FCC ID

**5) active interface unit**

- a) amplifies uplink signal from **host unit** for transmit by donor antenna
- b) attenuates downlink from donor antenna
- c) coax cable connection between **host** and **active interface unit**
- d) usually has separate FCC ID; in some cases could be combined/included with **host** as one enclosure

**GENERAL DEFINITIONS FOR CERTIFICATION PURPOSES**

The following three general definitions follow from those stated in the Part 22, 24, and 90 rule sections as listed above. Two of the definitions replace previous EAB internal definitions given for booster, repeater and extender. The general term “extender” is the same as booster, but booster should be used rather than extender. The general term “translator” is the same as repeater, but repeater should be used rather than translator.

**External radio frequency power amplifier (ERFPA)** - any device which, (1) when used in conjunction with a radio transmitter signal source, is capable of amplification of that signal, and (2) is not an integral part of a radio transmitter as manufactured. The EAS equipment class AMP is used only for an ERFPA device inserted between a transmitter (TNB/PCB) and an antenna (has only one antenna port)

**Booster** is a device that automatically reradiates signals from base transmitters without channel translation, for the purpose of improving the reliability of existing service by increasing the signal strength in dead spots. An “in-building radiation system” is a signal booster. These devices are not intended to extend the size of coverage from the originating base station. A booster can be either single or multiple channels.

**Repeater** is a device that retransmits the signals of other stations. Repeaters are different from boosters in that they can include frequency translation and can extend coverage beyond the design of the original base station. A repeater is typically single channel but can also be multiple channels.

ERFPA (AMP) and boosters/repeaters (TNB/PCB) can generally be authorized for all rule parts except 15 and 18.

Tests should be done with each typical signal. e.g., for F3E emissions use 2500 Hz with 2.5 or 5 kHz deviation. Use of CW signal for some tests is acceptable in lieu of actual emission, in some cases when CW signal gives worst case.

**The EUT belongs to AMP class.**

## 7.2 Test Procedure & Measurement Data

Test modulation and frequency  
PCS Band

| Modulation | Lowest frequency | Middle frequency | Highest frequency |
|------------|------------------|------------------|-------------------|
| TDMA       | 1931.0           | 1960.0           | 1989.0            |
| EDGE       | 1931.0           | 1960.0           | 1989.0            |
| GSM        | 1931.0           | 1960.0           | 1989.0            |
| CDMA       | 1932.0           | 1960.0           | 1988.0            |
| WCDMA      | 1933.0           | 1960.0           | 1987.0            |

General Test Setup:

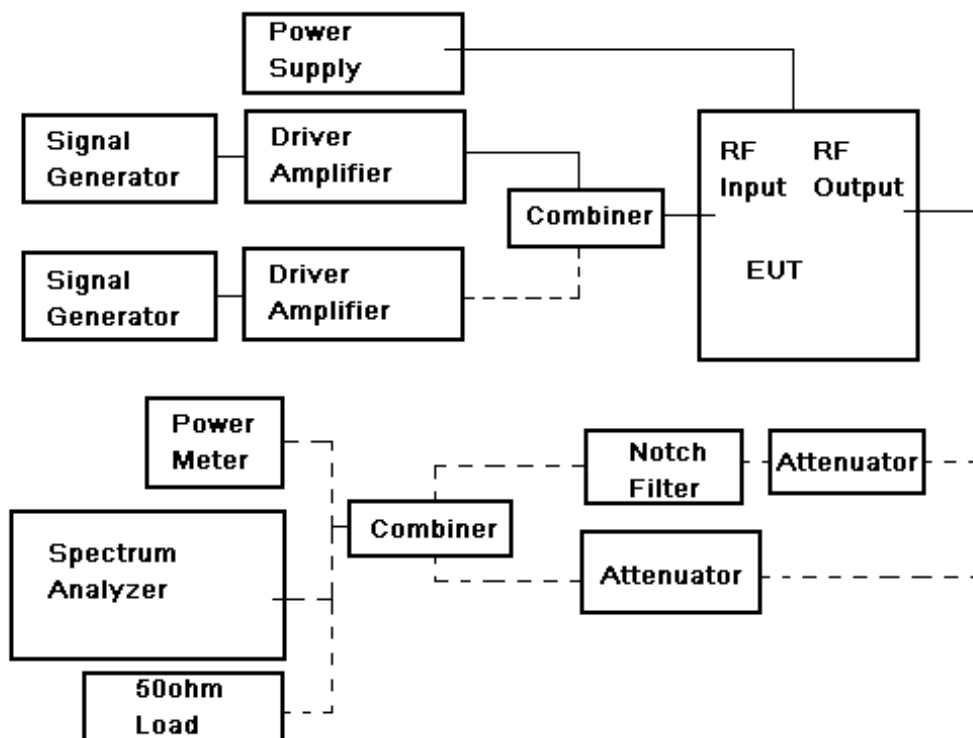

According to the tune up procedure, test the EUT antenna output port with the power output achieve the nominal output power, N+1 and 4 in 4 out system achieve 51dBm, 4x2 system achieve 54dBm.



7.2.1 RF Output Power

Test Date: 17 to 19 June 2009

Test Requirement: FCC part 24.232(a)&(b)

24.232(a) Base stations are limited to 1640 watts peak equivalent isotropically radiated power (EIRP) with an antenna height up to 300 meters HAAT, except as described in paragraph (b) below. See §24.53 for HAAT calculation method. Base station antenna heights may exceed 300 meters with a corresponding reduction in power; see Table 1 of this section. The service area boundary limit and microwave protection criteria specified in §§24.236 and 24.237 apply.

Table 1—Reduced Power for Base Station Antenna Heights Over 300 Meters

| HAAT in meters | Maximum EIRP watts |
|----------------|--------------------|
| ≤ 300          | 1640               |
| ≤ 500          | 1070               |
| ≤ 1000         | 490                |
| ≤ 1500         | 270                |
| ≤ 2000         | 160                |

24.232(b) Base stations that are located in counties with population densities of 100 persons or fewer per square mile, based upon the most recently available population statistics from the Bureau of the Census, are limited to 3280 watts peak equivalent isotropically radiated power (EIRP) with an antenna height up to 300 meters HAAT; See §24.53 for HAAT calculation method. Base station antenna heights may exceed 300 meters with a corresponding reduction in power; see Table 2 of this section. The service area boundary limit and microwave protection criteria specified in §§24.236 and 24.237 apply. Operation under this paragraph must be coordinated in advance with all PCS licensees within 120 kilometers (75 miles) of the base station and is limited to base stations located more than 120 kilometers (75 miles) from the Canadian border and more than 75 kilometers (45 miles) from the Mexican border.

Table 2—Reduced Power for Base Station Antenna Heights Over 300 Meters

| HAAT in meters | Maximum EIRP watts |
|----------------|--------------------|
| ≤ 300          | 3280               |
| ≤ 500          | 2140               |
| ≤ 1000         | 980                |
| ≤ 1500         | 540                |
| ≤ 2000         | 320                |

Test Method: FCC part 2.1046

EUT Operation:

Status: The output power of EUT be set to maximum value.

Conditions: Normal conditions

Application: PCS Band RF output ports

Test Configuration:

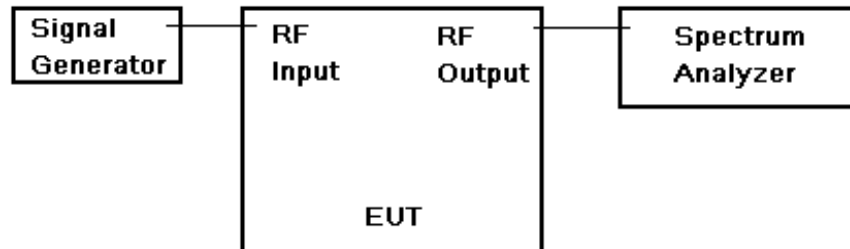

Fig.1 RF Output Power test configuration

Test Procedure:

RF out put power test procedure:

1.
  - a) Connect the equipment as illustrated, when the output power is over the max value of the Spectrum Analyzer, add the attenuator to avoid destroying the facility.
  - b) Set the center frequency of the spectrum analyzer to the assigned transmitter frequency, key the transmitter, and set the level of the carrier to the full scale reference line.
  - c) do not apply any tone to modulate the EUT.
  - d1) Adjust the spectrum analyzer for the following settings:
    - 1) Resolution Bandwidth >> the carrier bandwidth,
    - 2) Video Bandwidth refer to standard requirement.
  - d2) Use spectrum analyzer channel power measurement function;
  - e ) Record the frequencies and levels of carrier power;
  - f ) Calculate the signal link way loss and final power value.
- Or 2.
  - a) Connect the equipment as illustrated;
  - b) Read the value from the power meter;
  - c) Calculate the signal link way loss and final power value.

Remark:

Output power –

. Power on Form 731 should be clearly understood as either composite of multichannels or per carrier. If power is composite include in comments field: "Power output listed is composite for multi-channel operation."

. Check that the input drive level is at maximum input rating and maximum gain settings for all tests. Check both uplink and downlink input levels. See manual or

brochures/technical description for maximum rating. May need to check FCC identifier of transmitter used for tests.

. Confirm device can not operate in saturation. Are there means to control maximum power and to assure linear operation (use in system configuration may be necessary)? How is saturation or over-modulation prevented for pulsed signal inputs?



7.2.1.1 Measurement Record:

4x2 system

| Per channel Power, Input=33dBm                                   |      |      |      |      |       |
|--|------|------|------|------|-------|
|  | TDMA | GSM  | EDGE | CDMA | WCDMA |
| Frequency Band(1930MHz ~ 1990MHz),Measure Max Out put power(dBm) |      |      |      |      |       |
| Lowest Frequency   | 54.0 | 54.0 | 54.0 | 54.0 | 54.0  |
| Middle Frequency   | 54.0 | 54.0 | 54.0 | 54.0 | 54.0  |
| Highest Frequency  | 54.0 | 54.0 | 54.0 | 54.0 | 54.0  |
| Max value in W   |      |      |      |      |       |
| PCS Band   | 251  | 251  | 251  | 251  | 251   |

N+1 system, 4 in 4 out system

| Per channel Power, Input=33dBm                                   |      |      |      |      |       |
|--|------|------|------|------|-------|
|  | TDMA | GSM  | EDGE | CDMA | WCDMA |
| Frequency Band(1930MHz ~ 1990MHz),Measure Max Out put power(dBm) |      |      |      |      |       |
| Lowest Frequency   | 51.0 | 51.0 | 51.0 | 51.0 | 51.0  |
| Middle Frequency   | 51.0 | 51.0 | 51.0 | 51.0 | 51.0  |
| Highest Frequency  | 51.0 | 51.0 | 51.0 | 51.0 | 51.0  |
| Max value in W   |      |      |      |      |       |
| Cellular Band  | 126  | 126  | 126  | 126  | 126   |

Remark: test in single channel status, output power is test in full amplifying status.

For the EUT power output can adjust by the software, so all the power output status is being nominal power output status, the adjust procedure refer to the docomument " tune up procedure".

**Note: Conducted output power tested. ERP was not tested because the amplifier does not come with an antenna.**

The manufacture under test (EUT) is a booster amplifier assembly. The manufacture does not provide an antenna for sale with this product. The end user of this product is to exercise proper engineering judgement to select the appropriate antenna to comply with the EIRP limitation set forth by FCC.



### 7.2.2 Conducted Spurious Emissions

Test Date: 17 to 19 June 2009

Test Requirement: FCC part 24.238(a)

24.238(a) Out of band emissions. The power of any emission outside of the authorized operating frequency ranges must be attenuated below the transmitting power (P) by a factor of at least  $43 + 10 \log(P)$  dB.

Test Method: FCC part 2.1051& part 24.238(b)

24.238(b) Measurement procedure. Compliance with these rules is based on the use of measurement instrumentation employing a resolution bandwidth of 1 MHz or greater. However, in the 1 MHz bands immediately outside and adjacent to the frequency block a resolution bandwidth of at least one percent of the emission bandwidth of the fundamental emission of the transmitter may be employed. A narrower resolution bandwidth is permitted in all cases to improve measurement accuracy provided the measured power is integrated over the full required measurement bandwidth ( i.e. 1 MHz or 1 percent of emission bandwidth, as specified). The emission bandwidth is defined as the width of the signal between two points, one below the carrier center frequency and one above the carrier center frequency, outside of which all emissions are attenuated at least 26 dB below the transmitter power.

EUT Operation:

Status: The output power of EUT be set to maximum value

Conditions: Normal conditions

Application: PCS Band RF output ports

Test Configuration:

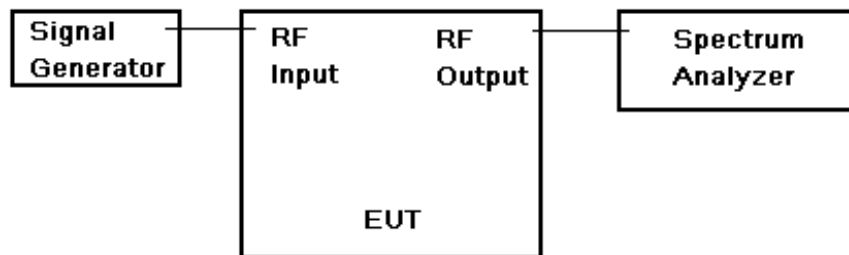
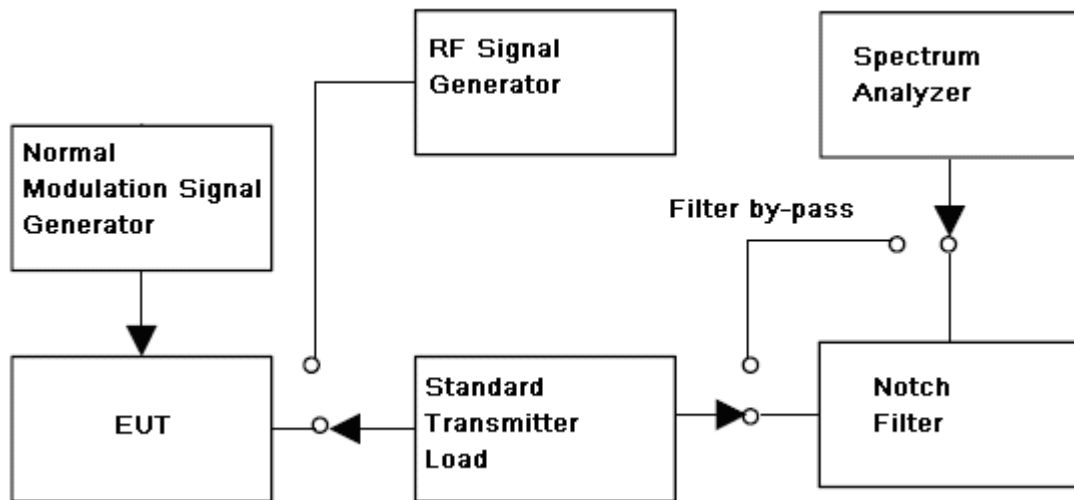

Fig.2. Conducted Spurious Emissions test configuration



**Test Procedure:**

**Conducted Emissions test procedure:**

- a) Connect the equipment as illustrated, with the notch filter by-passed, when the output power is over the max value of the Spectrum Analyzer, add the attenuator to avoid destroying the facility.
- b) Set the center frequency of the spectrum analyzer to the assigned transmitter frequency, key the transmitter, and set the level of the carrier to the full scale reference line.
- c) do not apply any tone to modulate the EUT.
- d) Adjust the spectrum analyzer for the following settings:
  - 1) Resolution Bandwidth,( base the standard, apply the different set),her is 100KHz for frequency band less than 1GHz, 1MHz for frequency over 1GHz;
  - 2) Video Bandwidth refer to standard requirement.
- e) Adjust the center frequency of the spectrum analyzer for incremental coverage of the range from:
  - 1) the lowest radio frequency generated in the equipment, it can be 9KHz base the test method, here select 30MHz as lowest frequency start point;
  - 2) the highest radion frequency shall higher than 10 times of carrier frequency;
- f ) Record the frequencies and levels of spurious emissions from step e)

**Remark:**

The notch filter is used for avoid the EUT fundamental carrier output power making the spectrum overload and the harmonic spurious brought by it.

When the EUT fundamental carrier is not enough to make the status, the notch filter could be not used.



7.2.2.1 Measurement Record:

Pretest 54dBm output system and 51dBm system,found the worse case in 54dBm system and report it.

PCS Band

PCS—TDMA down link(lowest frequency)

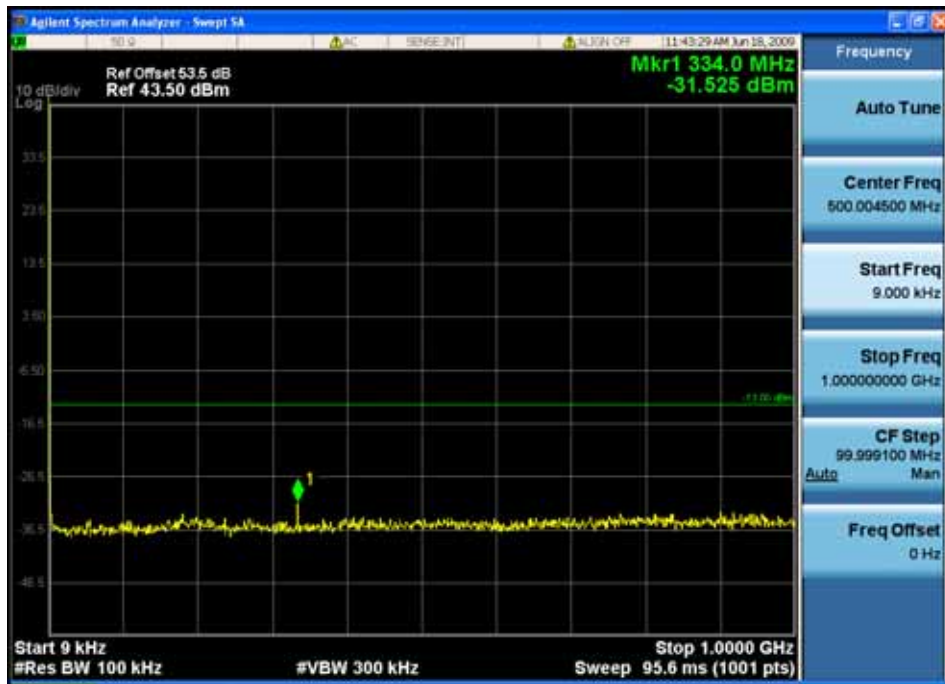

PCS—TDMA down link(lowest frequency)





# SGS-CSTC Standards Technical Services Co., Ltd.

Report No.: GLEMO09060172201

Page: 20 of 89

FCC ID: PX8TS-19-12XXXXXX

PCS—TDMA down link(middle frequency)

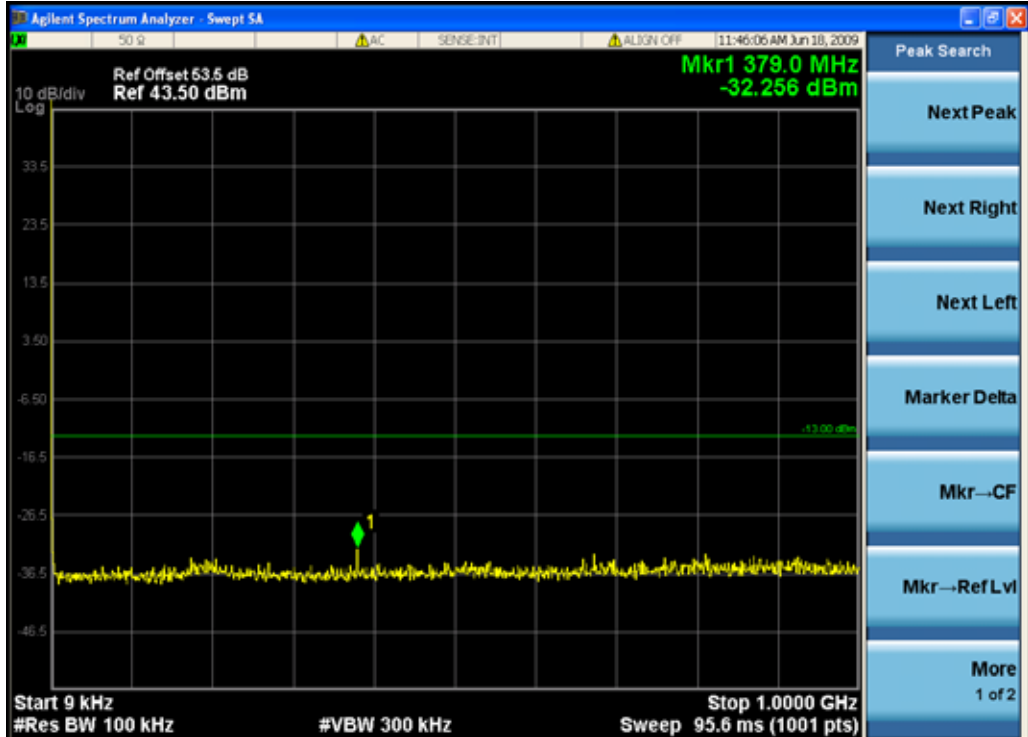

PCS—TDMA down link(middle frequency)

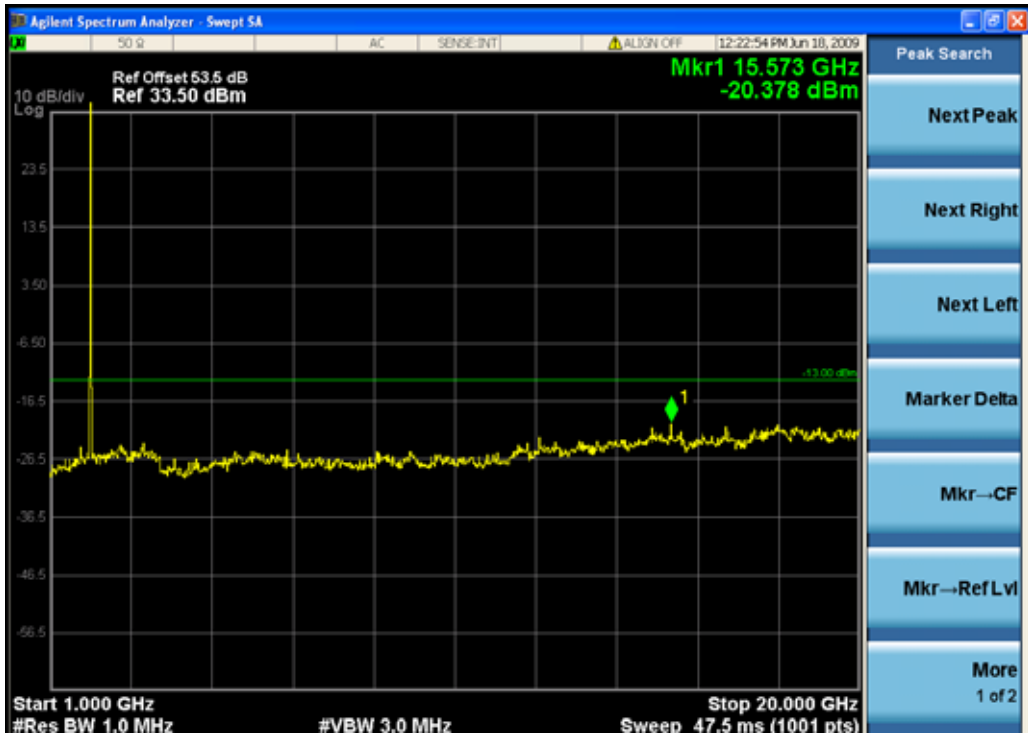



# SGS-CSTC Standards Technical Services Co., Ltd.

Report No.: GLEMO09060172201

Page: 21 of 89

FCC ID: PX8TS-19-12XXXXXX

PCS—TDMA down link(highest frequency)

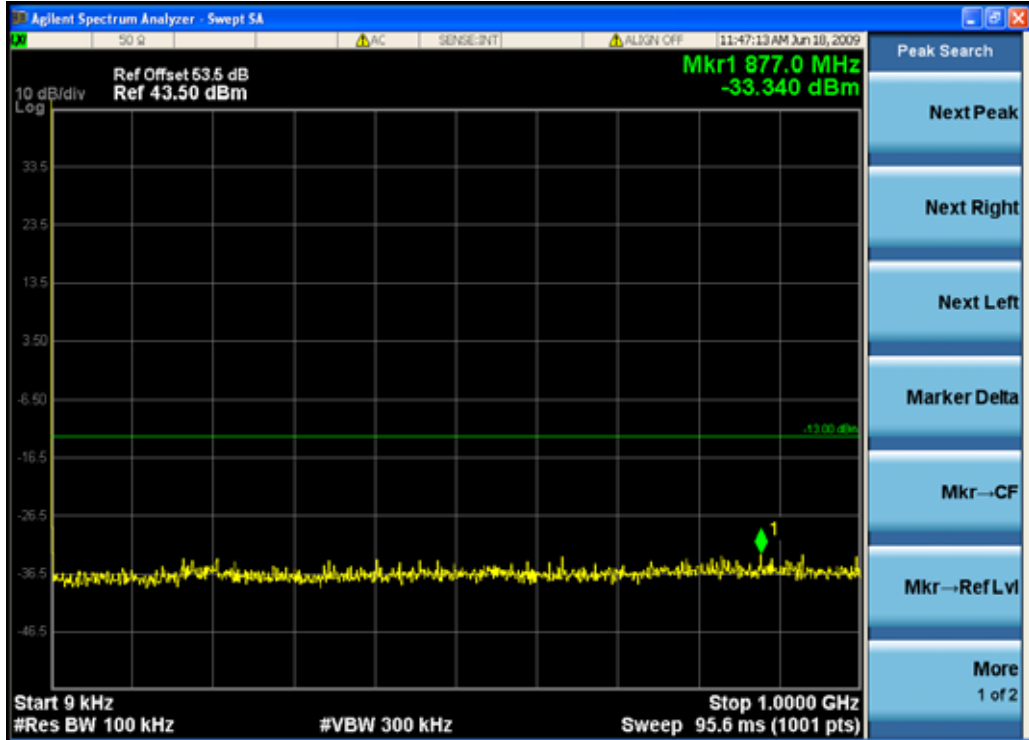

PCS—TDMA down link(highest frequency)





PCS Band

PCS—GSM down link(lowest frequency)

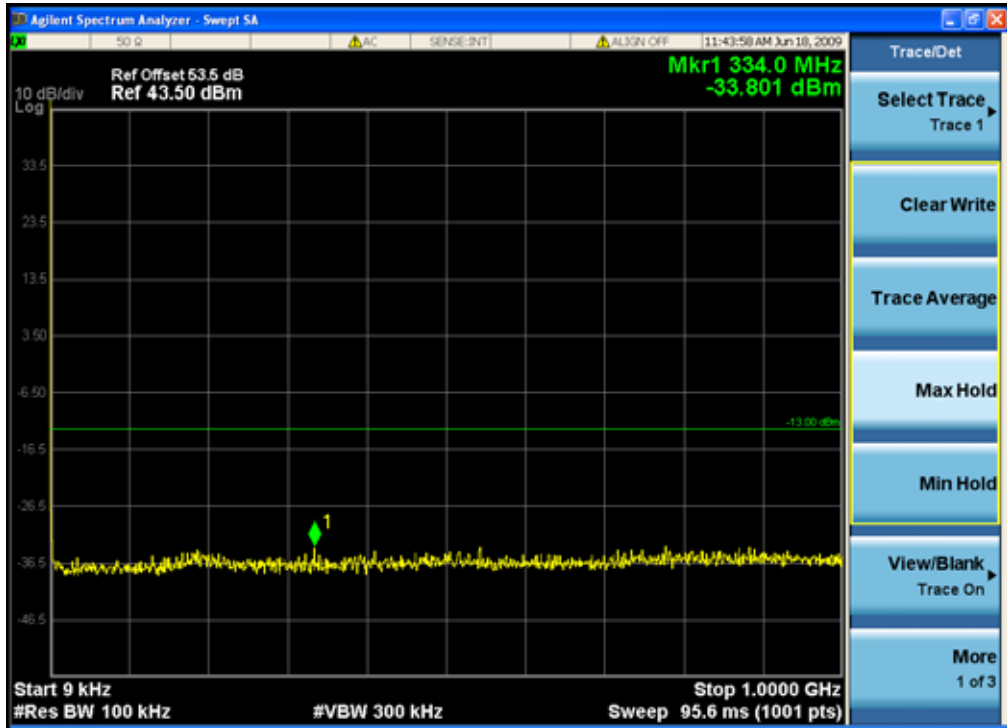

PCS—GSM down link(lowest frequency)

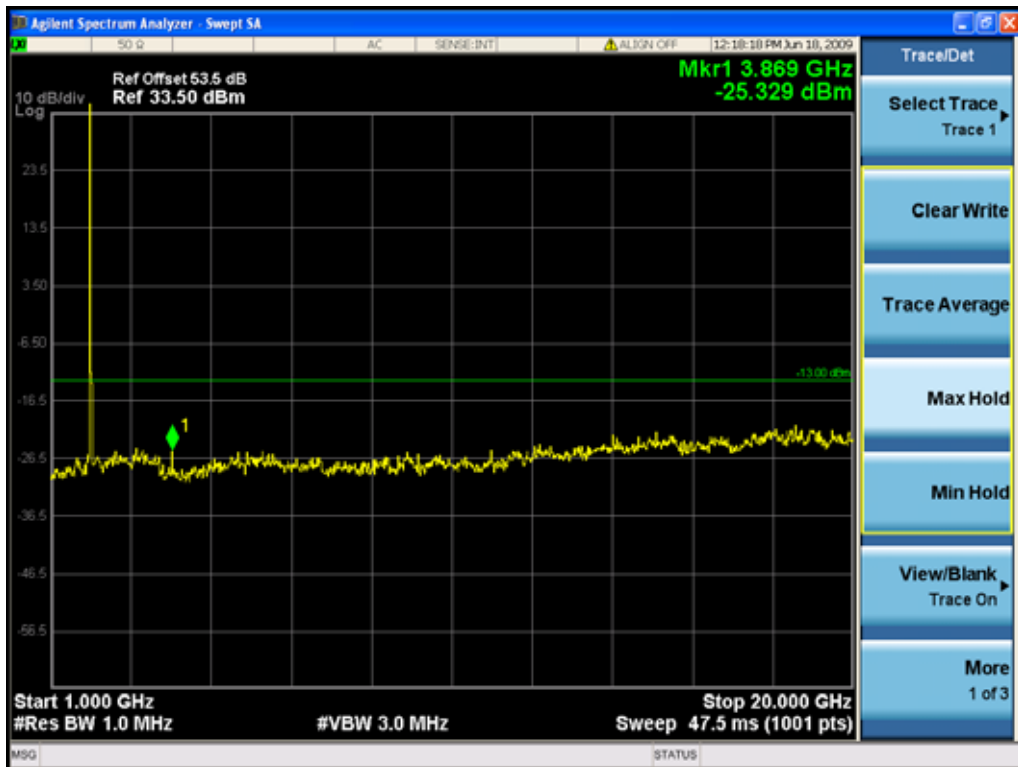



PCS—GSM down link(middle frequency)

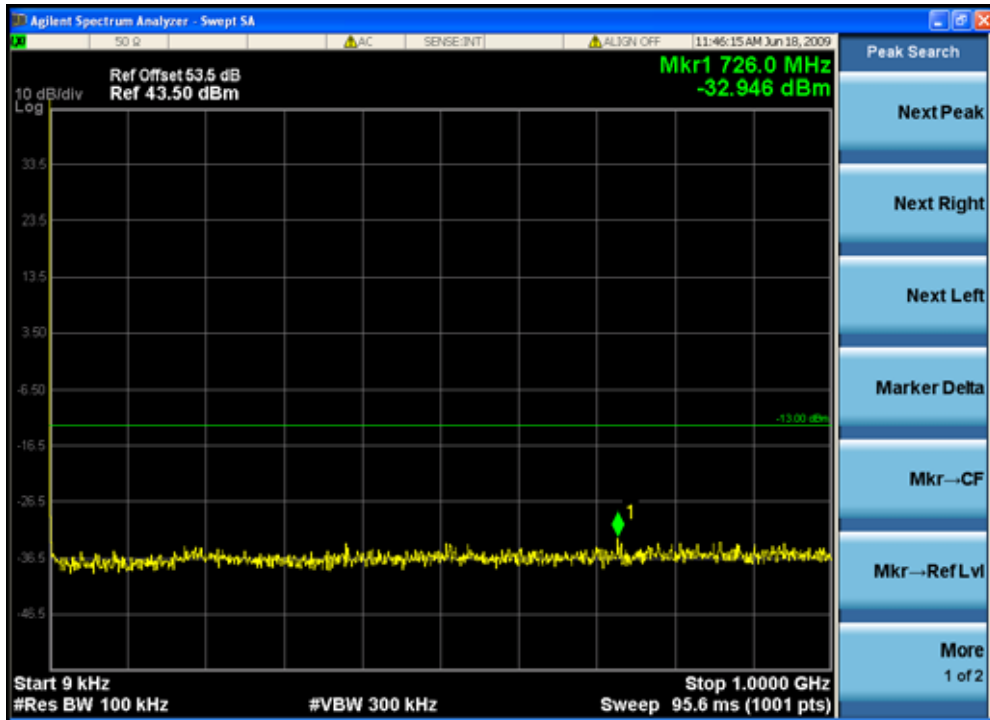

PCS—GSM down link(middle frequency)





# SGS-CSTC Standards Technical Services Co., Ltd.

Report No.: GLEMO09060172201

Page: 24 of 89

FCC ID: PX8TS-19-12XXXXXX

PCS—GSM down link(highest frequency)

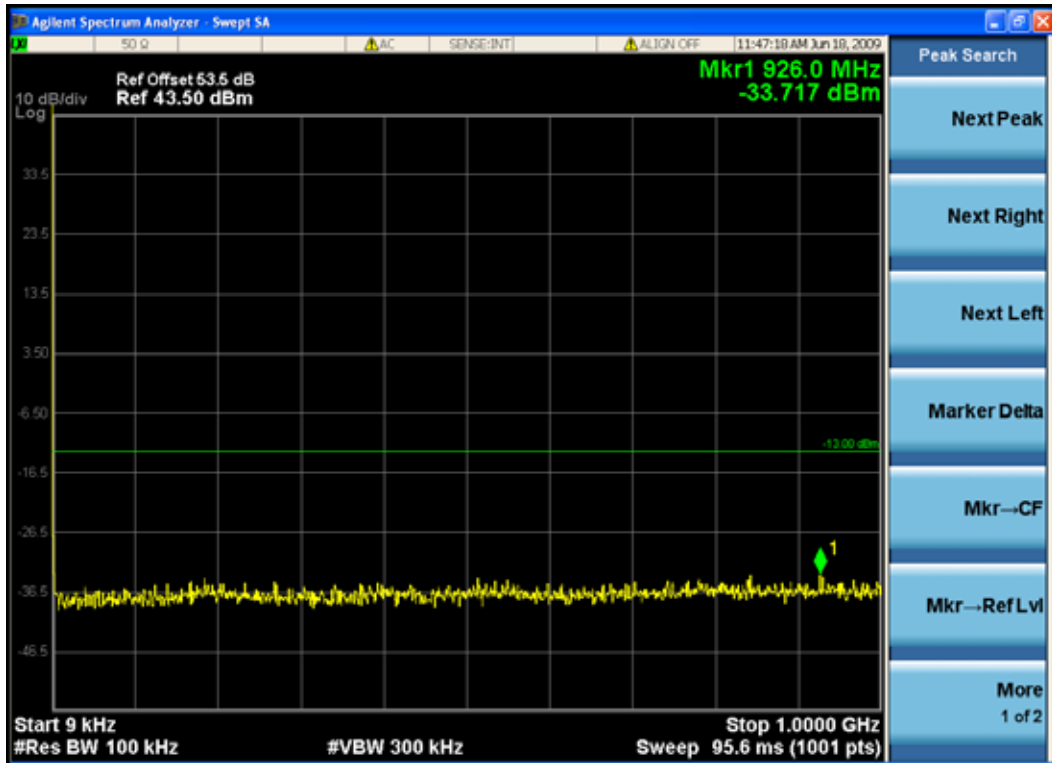

PCS—GSM down link(highest frequency)







PCS Band

PCS—EDGE down link(lowest frequency)

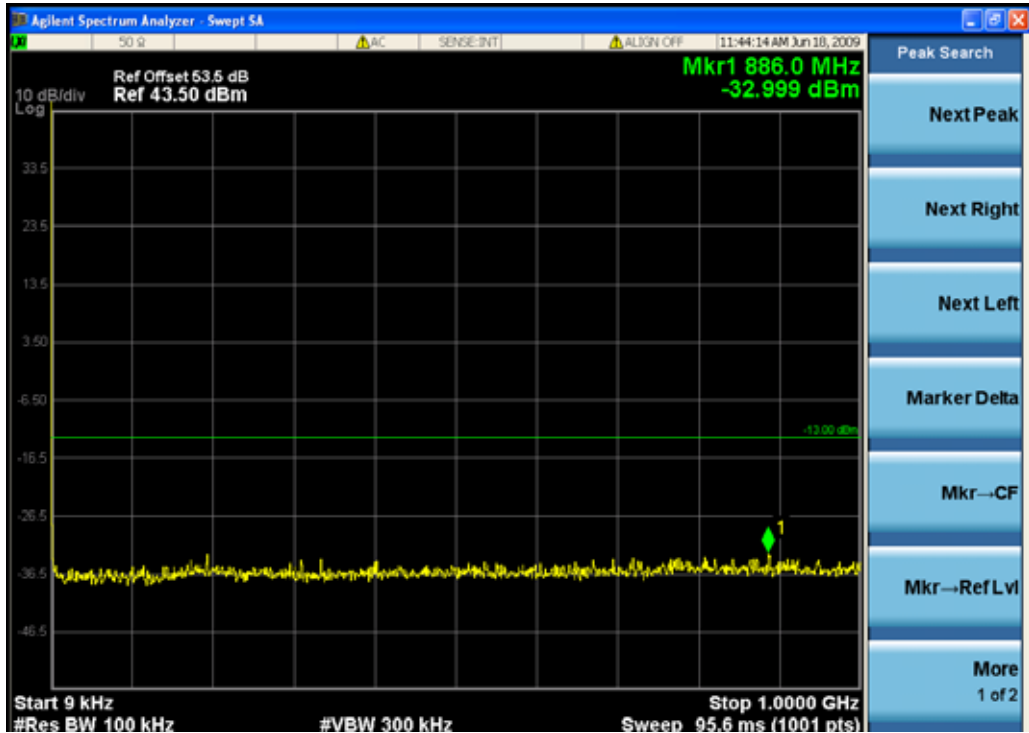

PCS—EDGE down link(lowest frequency)





# SGS-CSTC Standards Technical Services Co., Ltd.

Report No.: GLEMO09060172201

Page: 26 of 89

FCC ID: PX8TS-19-12XXXXXX

PCS—EDGE down link(middle frequency)

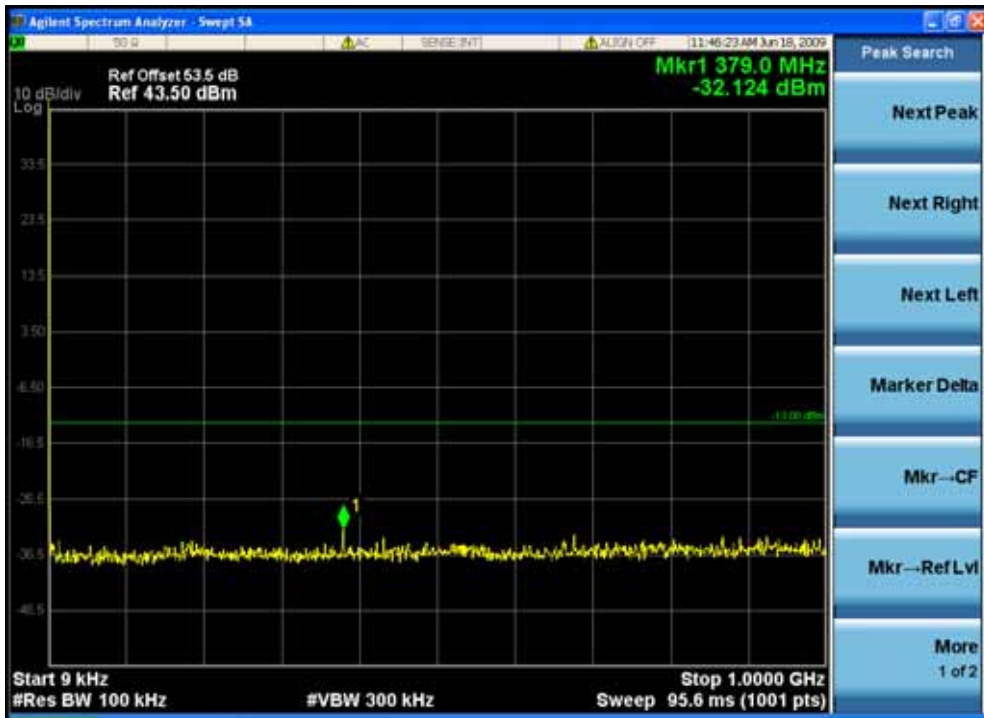

PCS—EDGE down link(middle frequency)





PCS—EDGE down link(highest frequency)

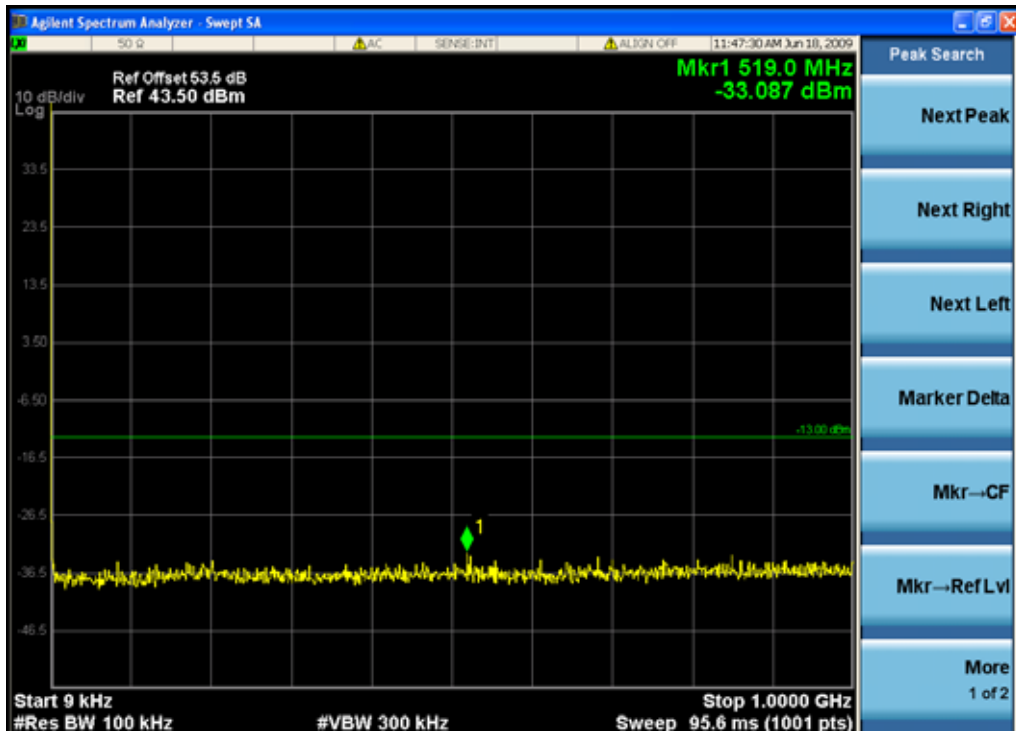

PCS—EDGE down link(highest frequency)

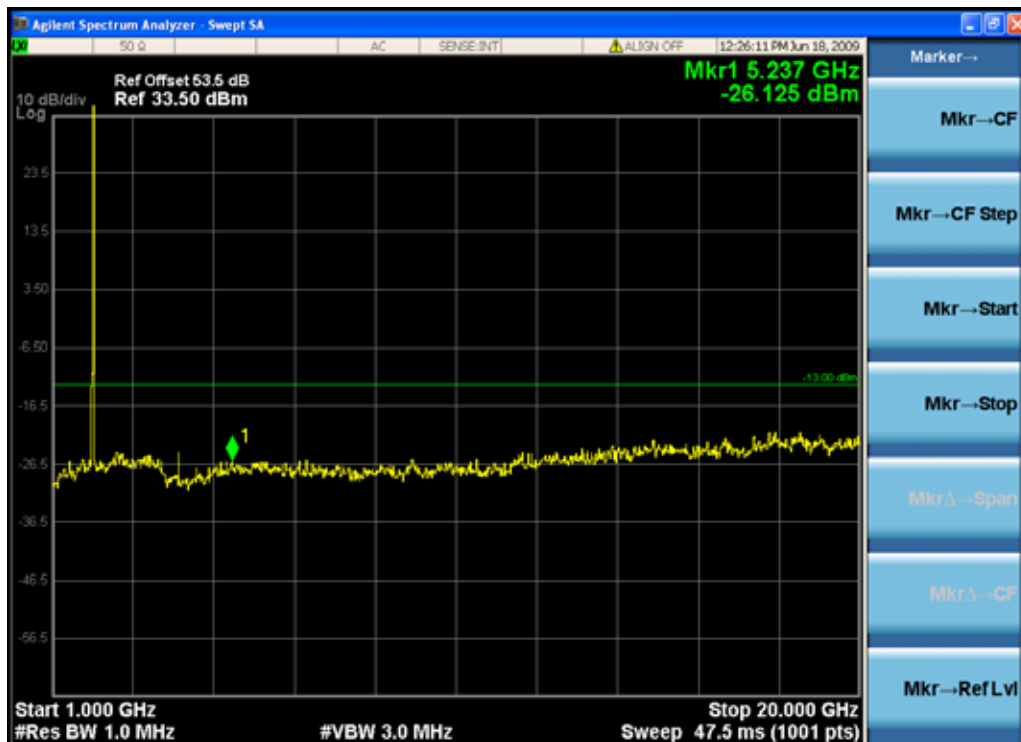



PCS Band

PCS—CDMA down link(lowest frequency)

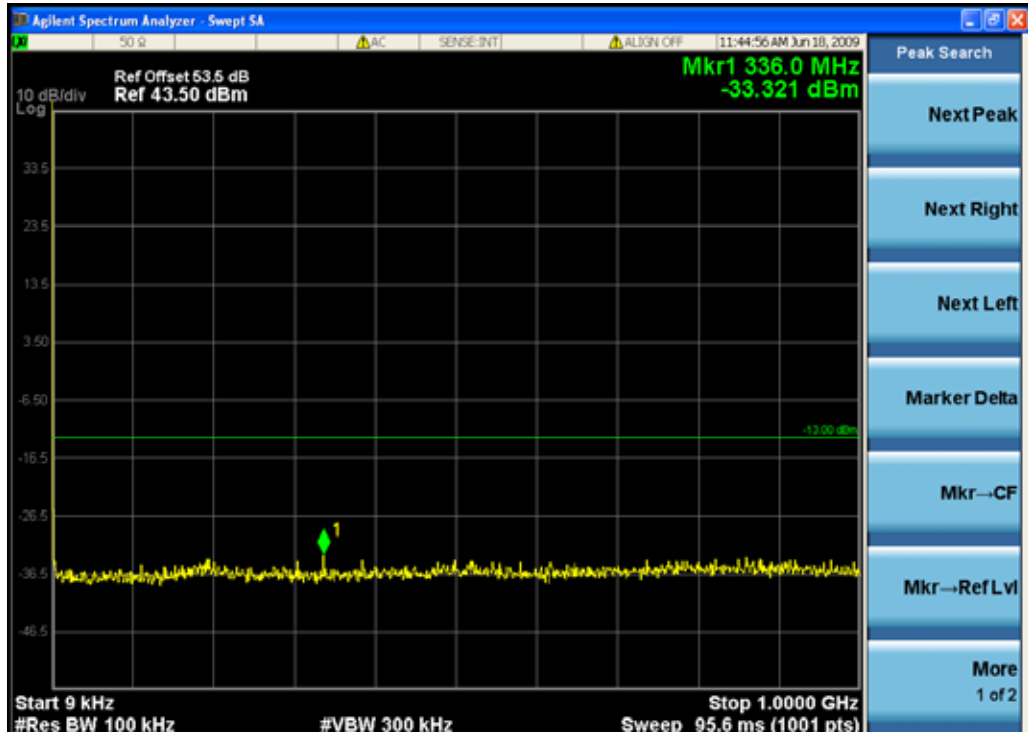

PCS—CDMA down link(lowest frequency)





PCS—CDMA down link(middle frequency)

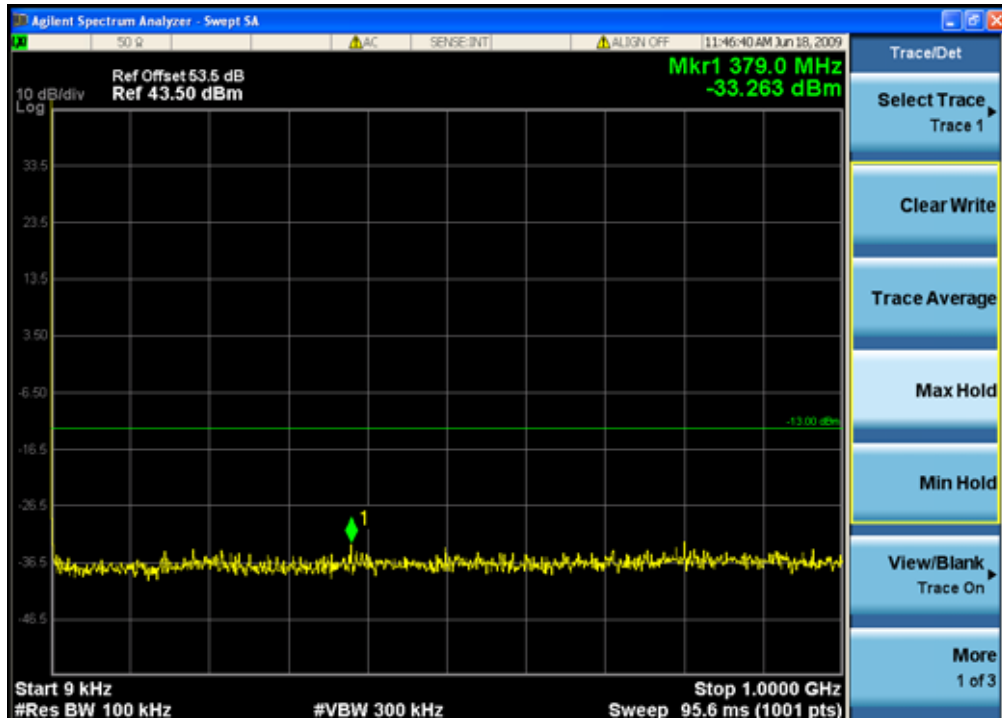

PCS—CDMA down link(middle frequency)





PCS—CDMA down link(highest frequency)

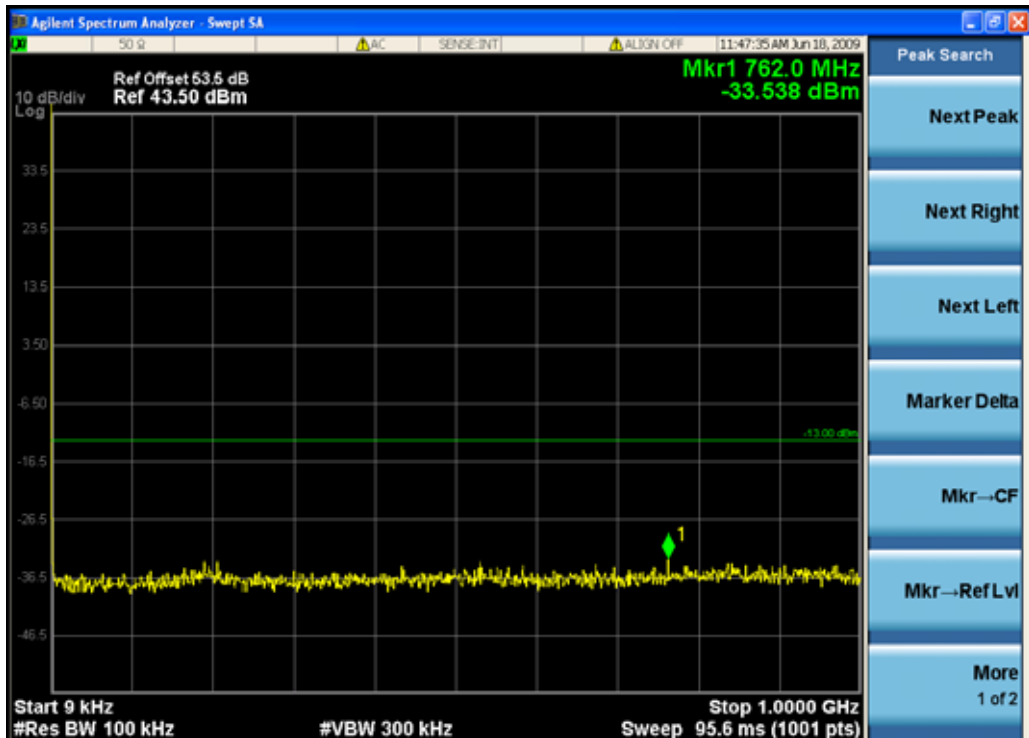

PCS—CDMA down link(highest frequency)

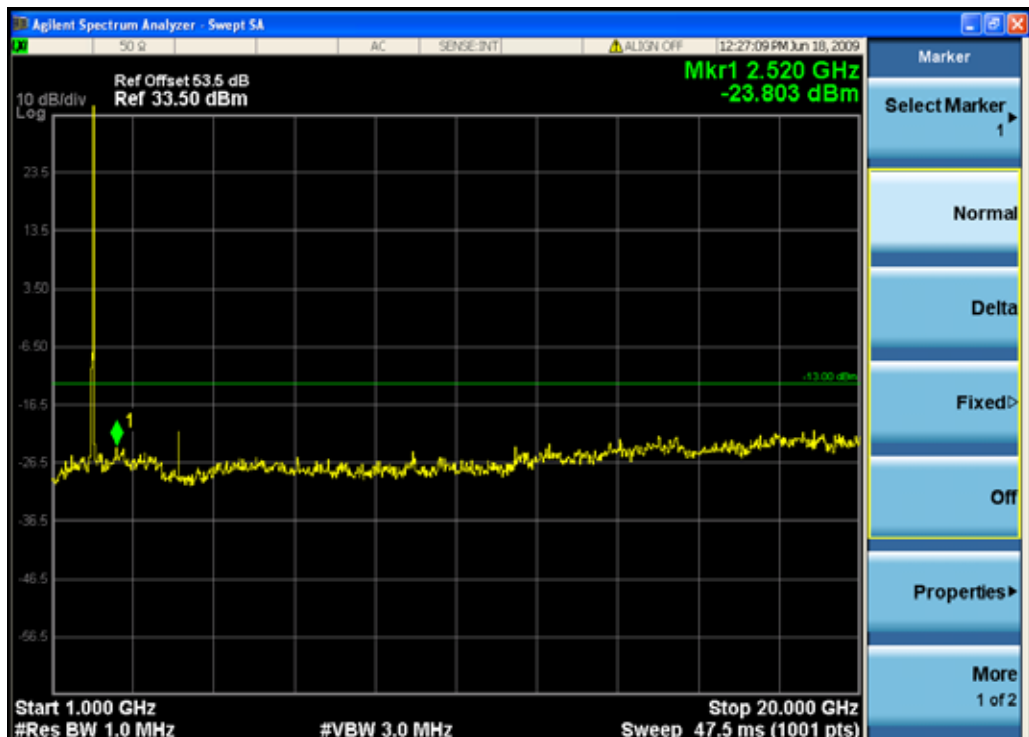



PCS Band

PCS—WCDMA down link(lowest frequency)

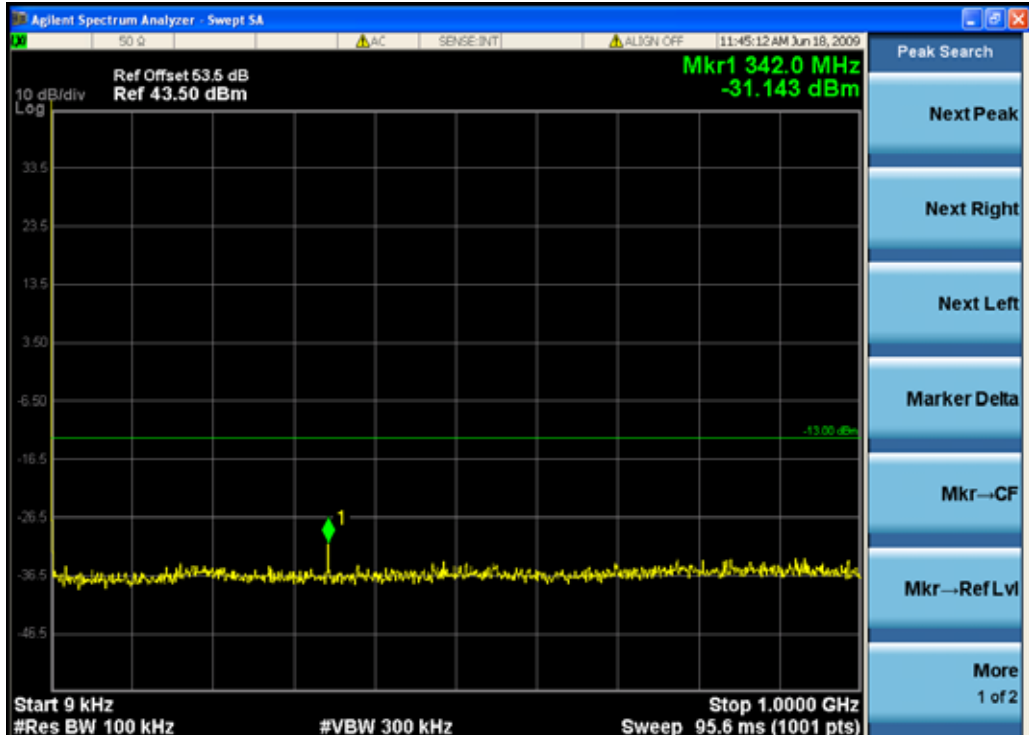

PCS—WCDMA down link(lowest frequency)

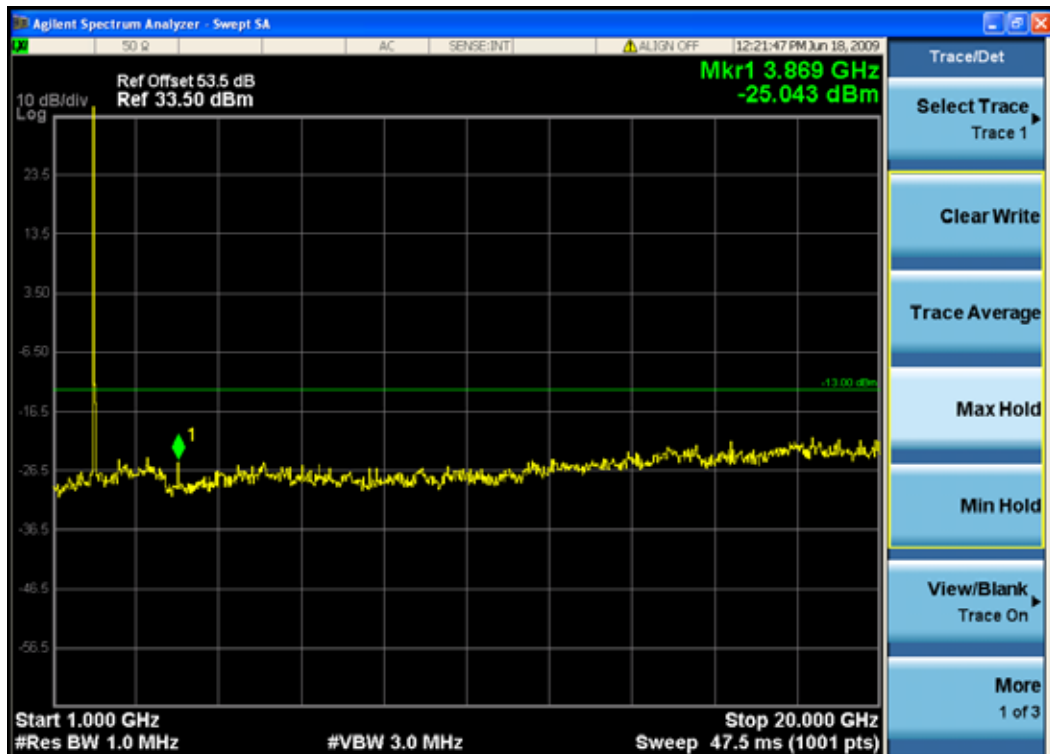



PCS—WCDMA down link(middle frequency)

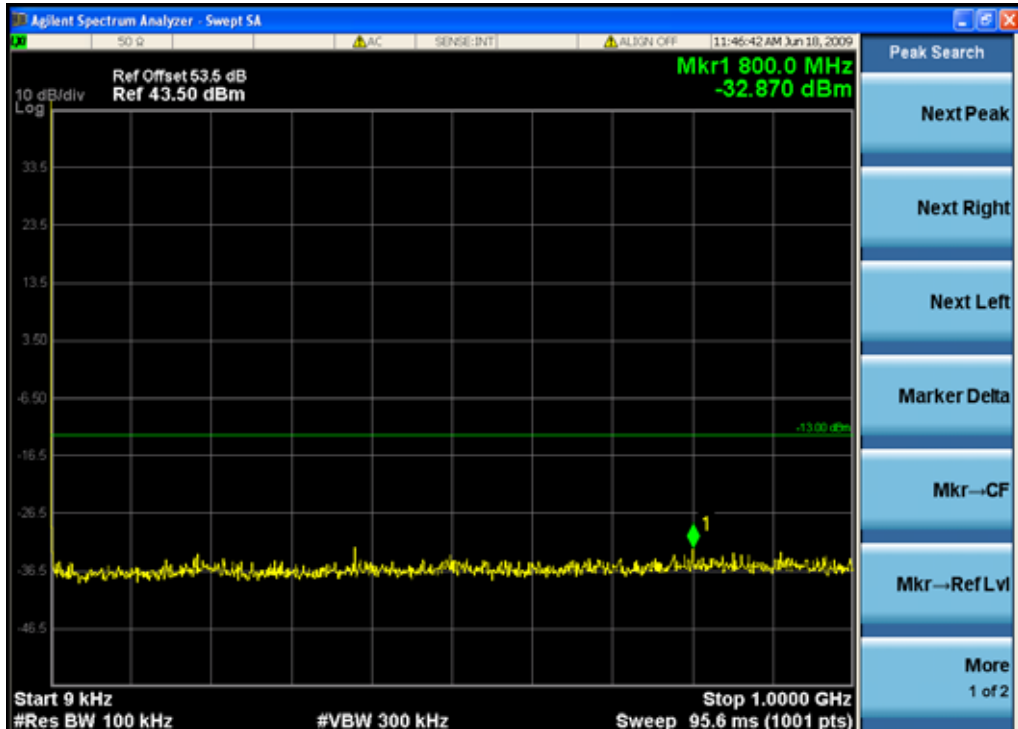

PCS—WCDMA down link(middle frequency)







# SGS-CSTC Standards Technical Services Co., Ltd.

Report No.: GLEMO09060172201

Page: 33 of 89

FCC ID: PX8TS-19-12XXXXXX

PCS—WCDMA down link(highest frequency)

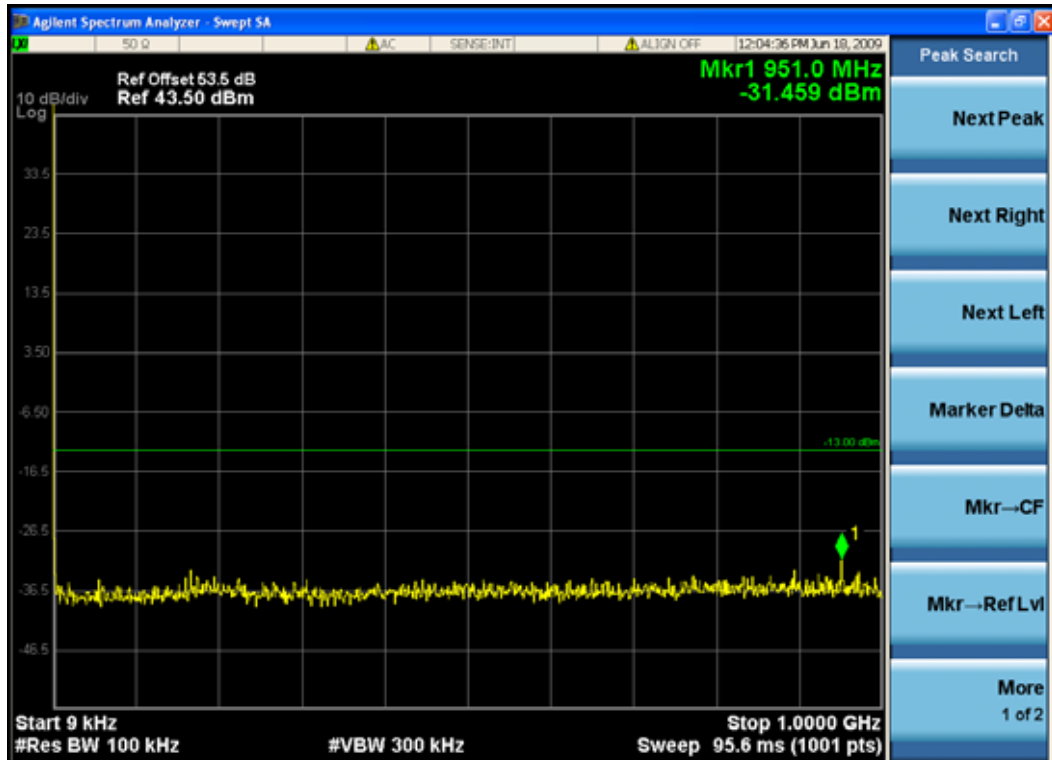

PCS—WCDMA down link(highest frequency)

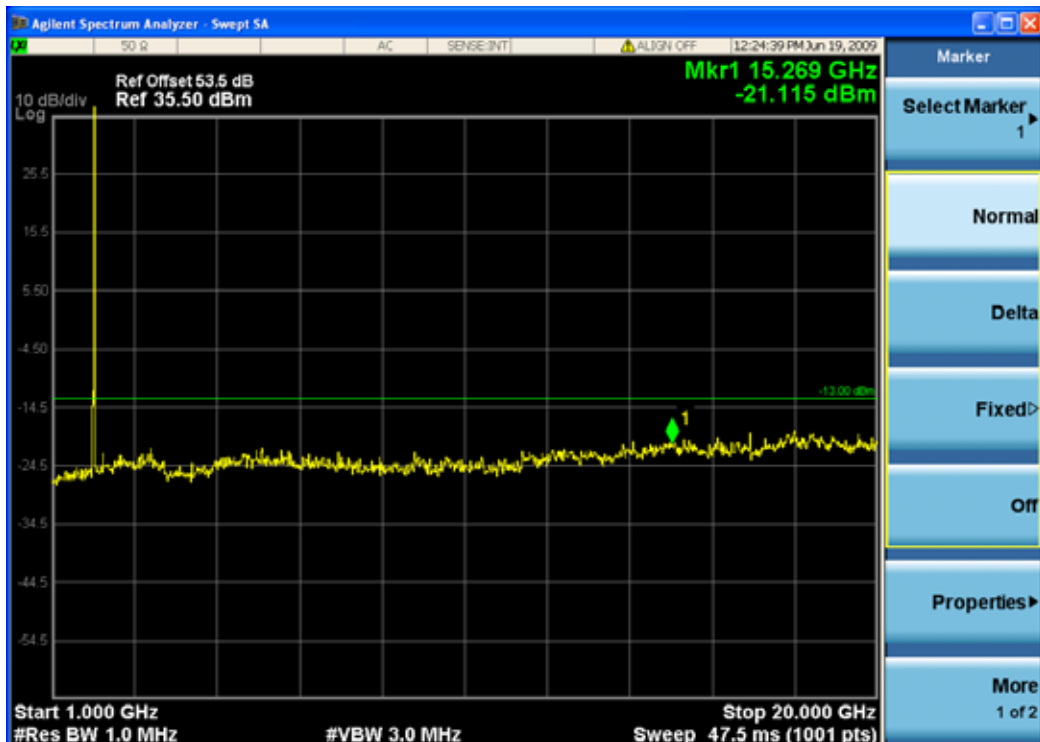

### 7.2.3 Band Edge & Intermodulation

Test Date: 17 to 19 June 2009

Test Requirement: FCC part 24.238(a)

24.238(a) Out of band emissions. The power of any emission outside of the authorized operating frequency ranges must be attenuated below the transmitting power (P) by a factor of at least  $43 + 10 \log(P)$  dB.

Test Method: FCC part 2.1051 & part 24.238(b) & 2-11-04/EAB/RF

24.238(b) Measurement procedure. Compliance with these rules is based on the use of measurement instrumentation employing a resolution bandwidth of 1 MHz or greater. However, in the 1 MHz bands immediately outside and adjacent to the frequency block a resolution bandwidth of at least one percent of the emission bandwidth of the fundamental emission of the transmitter may be employed. A narrower resolution bandwidth is permitted in all cases to improve measurement accuracy provided the measured power is integrated over the full required measurement bandwidth ( i.e. 1 MHz or 1 percent of emission bandwidth, as specified). The emission bandwidth is defined as the width of the signal between two points, one below the carrier center frequency and one above the carrier center frequency, outside of which all emissions are attenuated at least 26 dB below the transmitter power.

Test Configuration:

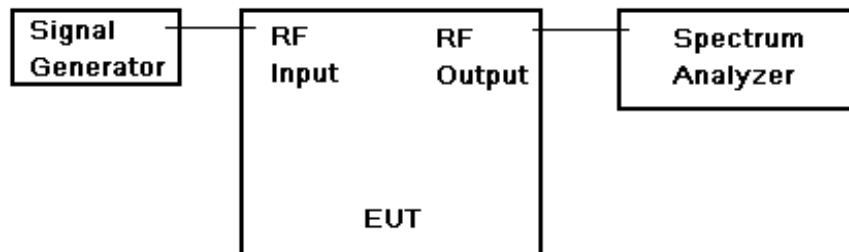

Fig.3. Band edge and Intermodulation test configuration

EUT Operation:

Status: The output power of EUT be set to maximum value.

Conditions: Normal conditions

Application: PCS Band RF output ports

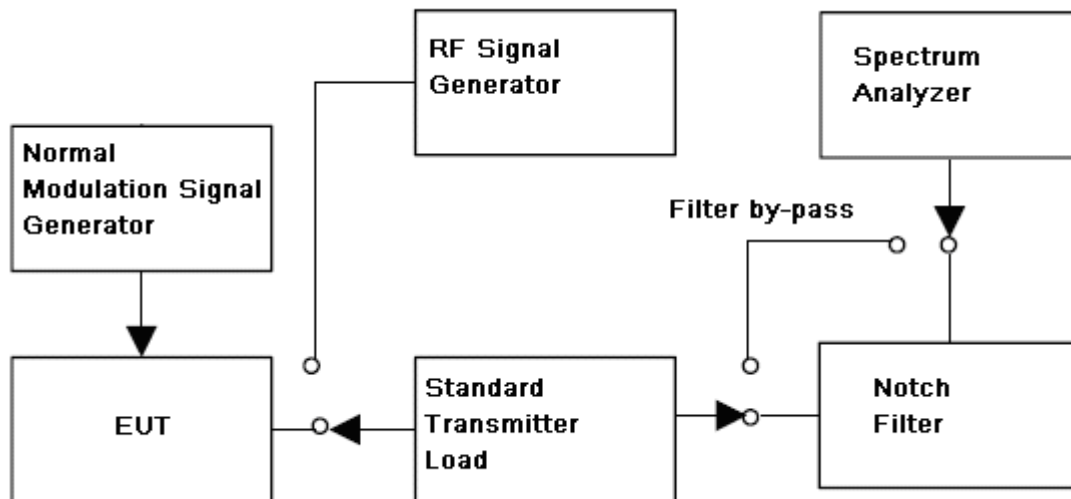

**Test Procedure:**

Conducted Emissions test procedure:

- a) Connect the equipment as illustrated, with the notch filter by-passed, when the output power is over the max value of the Spectrum Analyzer, add the attenuator to avoid destroying the facility.
- b) Set the center frequency of the spectrum analyzer to the assigned transmitter frequency, key the transmitter, and set the level of the carrier to the full scale reference line.
- c) do not apply any tone to modulate the EUT.
- d) Adjust the spectrum analyzer for the following settings:
  - 1) Resolution Bandwidth,( base the standard, apply the different set),here is 100KHz for frequency band less than 1GHz, 1MHz for frequency over 1GHz;
  - 2) Video Bandwidth refer to standard requirement.
- e) Adjust the center frequency of the spectrum analyzer for incremental coverage of the range from:
  - 1) the lowest radio frequency generated in the equipment, it can be 9KHz base the test method, here select 30MHz as lowest frequency start point;
  - 2) the highest radion frequency shall higher than 10 times of carrier frequency;
- f) Record the frequencies and levels of spurious emissions from step e)

**Remark:**

The notch filter is used for avoid the EUT fundamental carrier output power making the spectrum overload and the harmonic spurious brought by it.

When the EUT fundamental carrier is not enough to make the status, the notch filter could be not used.



## SGS-CSTC Standards Technical Services Co., Ltd.

Report No.: GLEMO09060172201

Page: 36 of 89

FCC ID: PX8TS-19-12XXXXXX

### Intermodulation Test Procedure:

1. Connect the equipment as illustrated;
2. Test the background noise level with all the test facilities;
3. Keep one transmitting path, all other connectors shall be connected by normal power or RF leads;
4. Select the attenuator to avoid the test receiver or spectrum analyzer being destroyed;
5. Keep the EUT continuously transmitting in max power;
6. Keep two signals are same in modulation type and level;
7. Measure the 3 order intermodulated product by the EUT( the sum of the two unwanted signal should be rated power);
6. Correct for all losses in the RF path;
7. Read the conducted spurious emissions of the EUT antenna port.
  - CW signal rather than typical signal is acceptable (for FM).
  - At maximum drive level, for each modulation: one test with three tones, or two tests (high-, low-band edge) with two tones
  - Limit usually is -13dBm conducted.
  - Not needed for Single Channel systems.
  - Combination of modulation types not needed.



7.2.3.1 Measurement Record:

Pretest 54dBm output system and 51dBm system,found the worse case in 54dBm system and report it.

54dBm output system

PCS Band

PCS—TDMA one signal input down link—Lower Edge

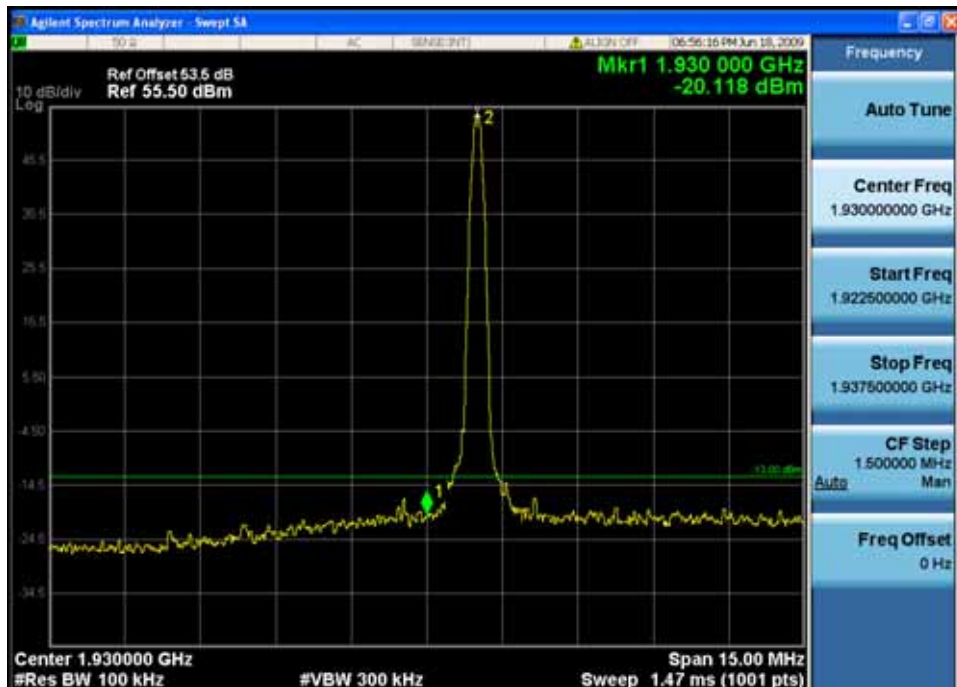

PCS—TDMA one signal input down link—Upper Edge

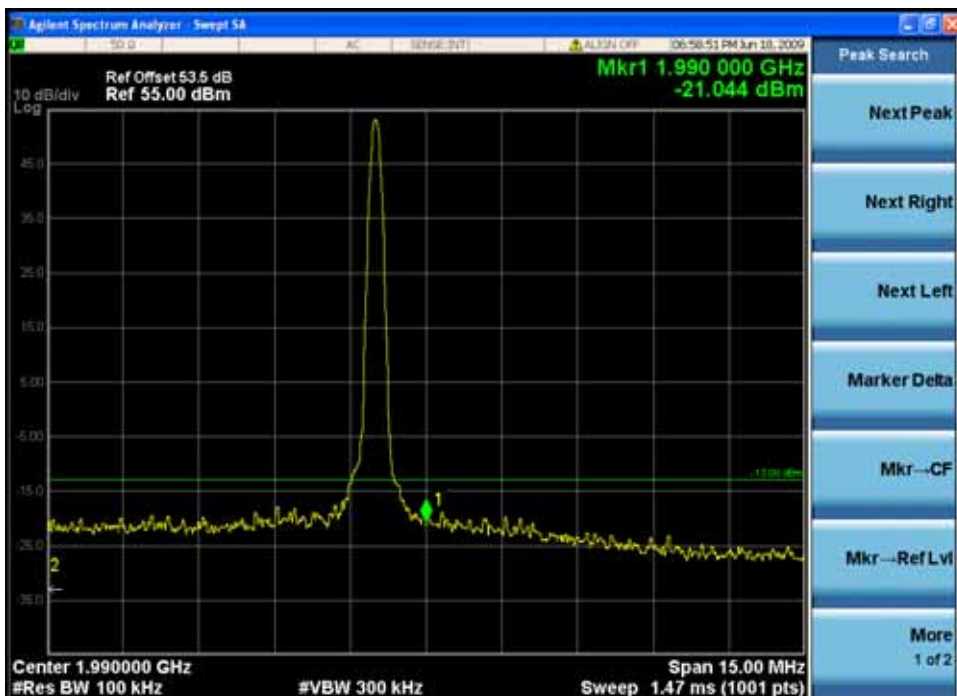



PCS—TDMA two signal input down link—Lower Edge

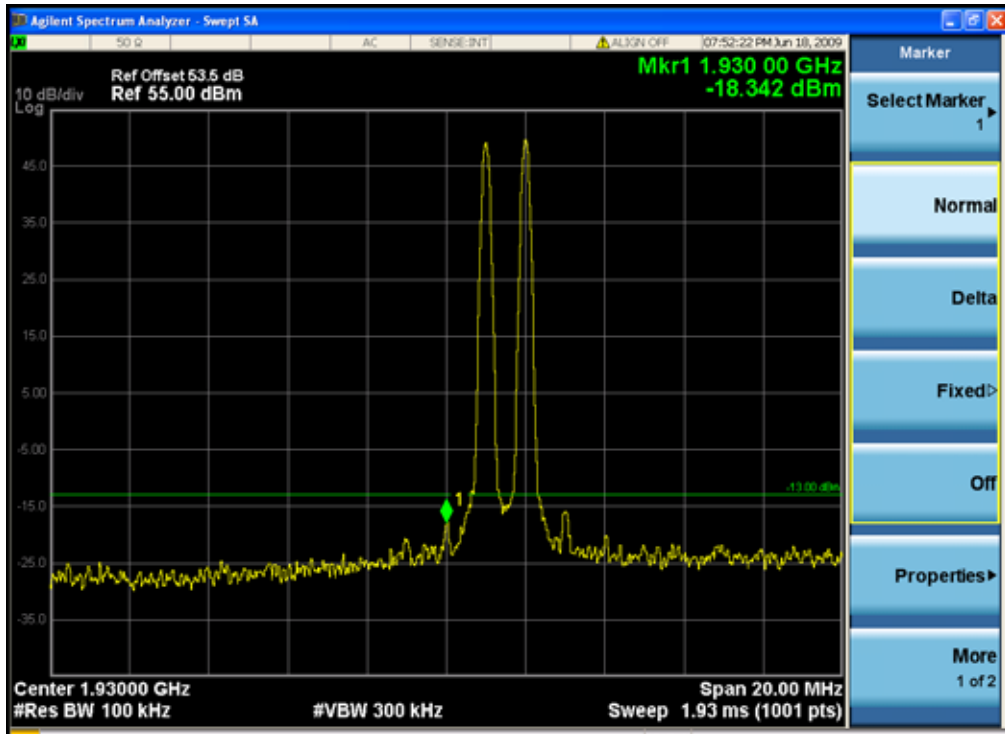

PCS—TDMA two signal input down link—Upper Edge

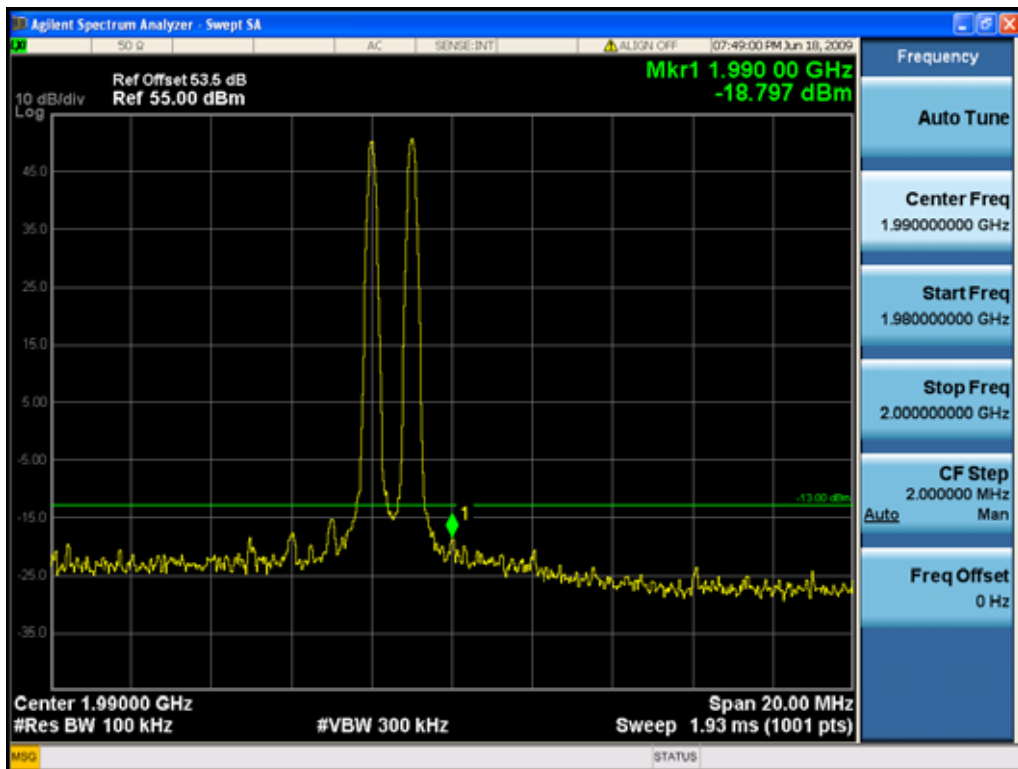



PCS Band

PCS—GSM one signal input down link—Lower Edge

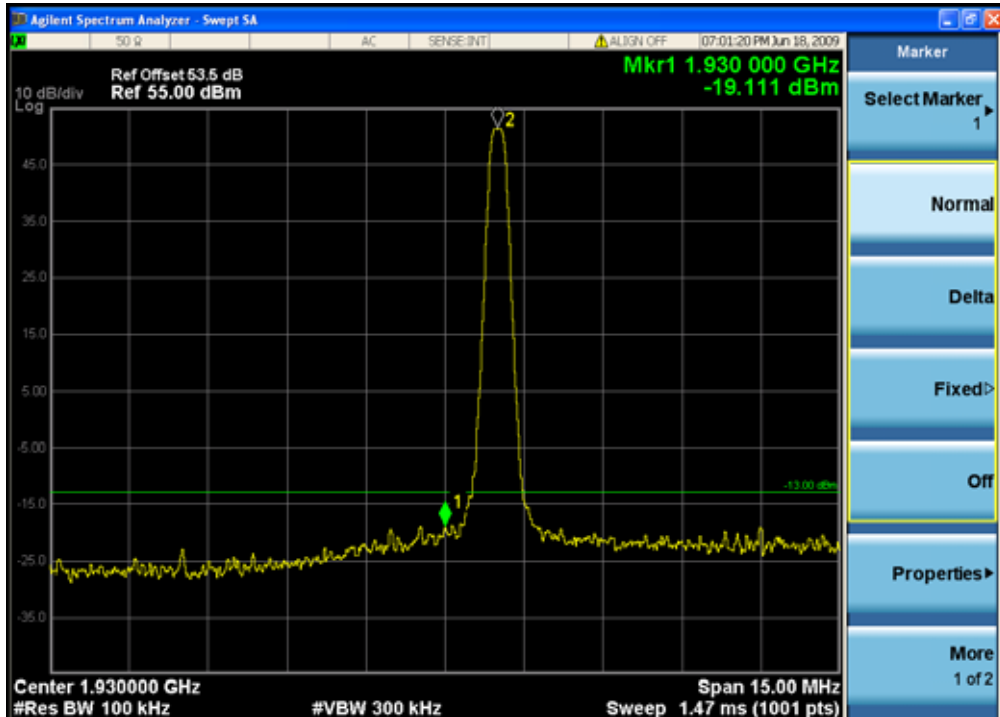

PCS—GSM one signal input down link—Upper Edge

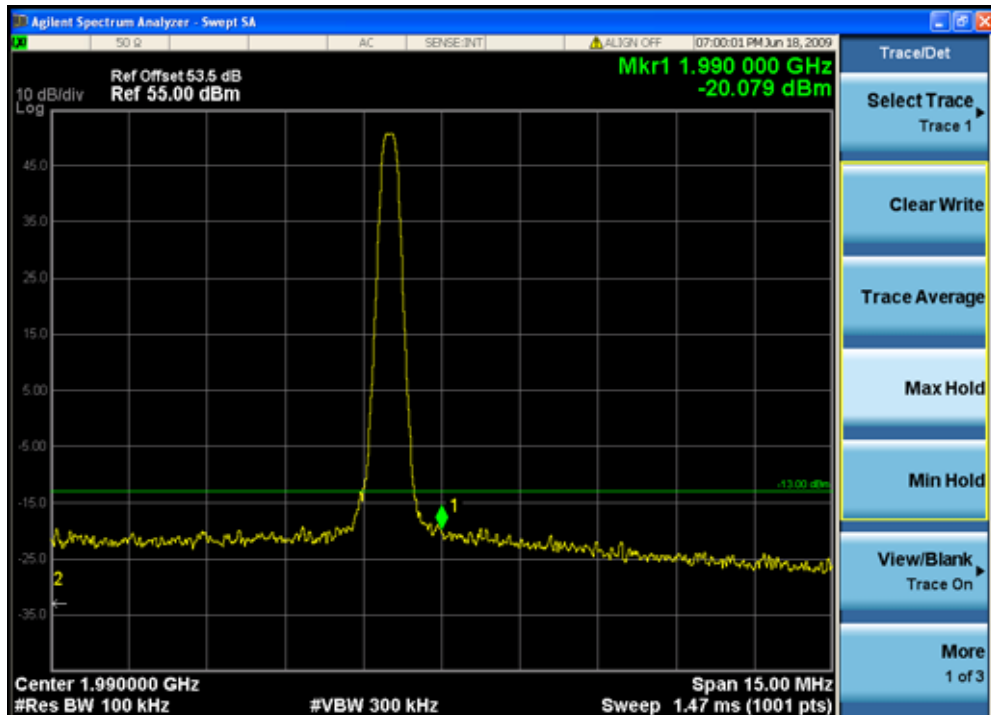



# SGS-CSTC Standards Technical Services Co., Ltd.

Report No.: GLEMO09060172201

Page: 40 of 89

FCC ID: PX8TS-19-12XXXXXX

## PCS—GSM two signal input down link—Lower Edge

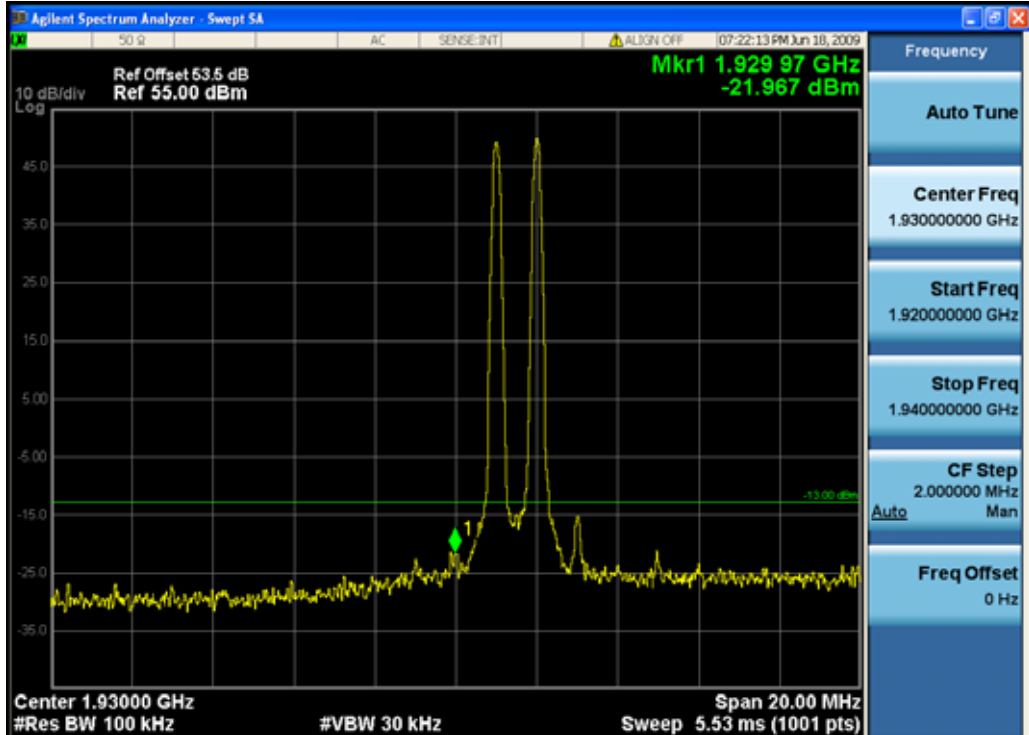

## PCS—GSM two signal input down link—Upper Edge

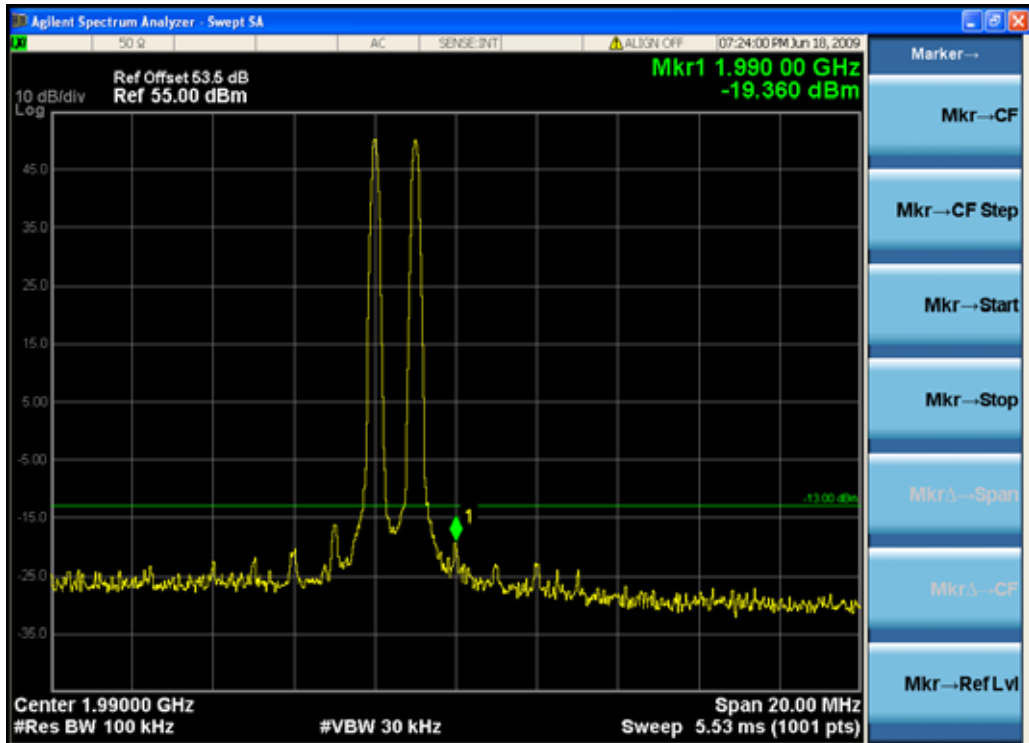





PCS Band

PCS—EDGE one signal input down link—Lower Edge

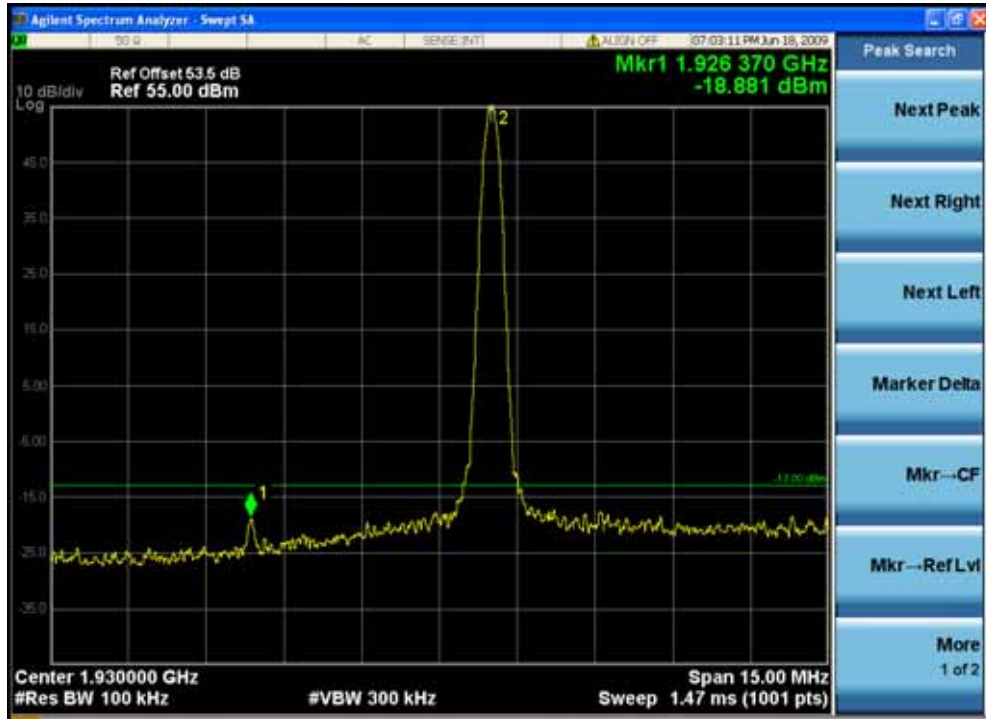

PCS—EDGE one signal input down link—Upper Edge

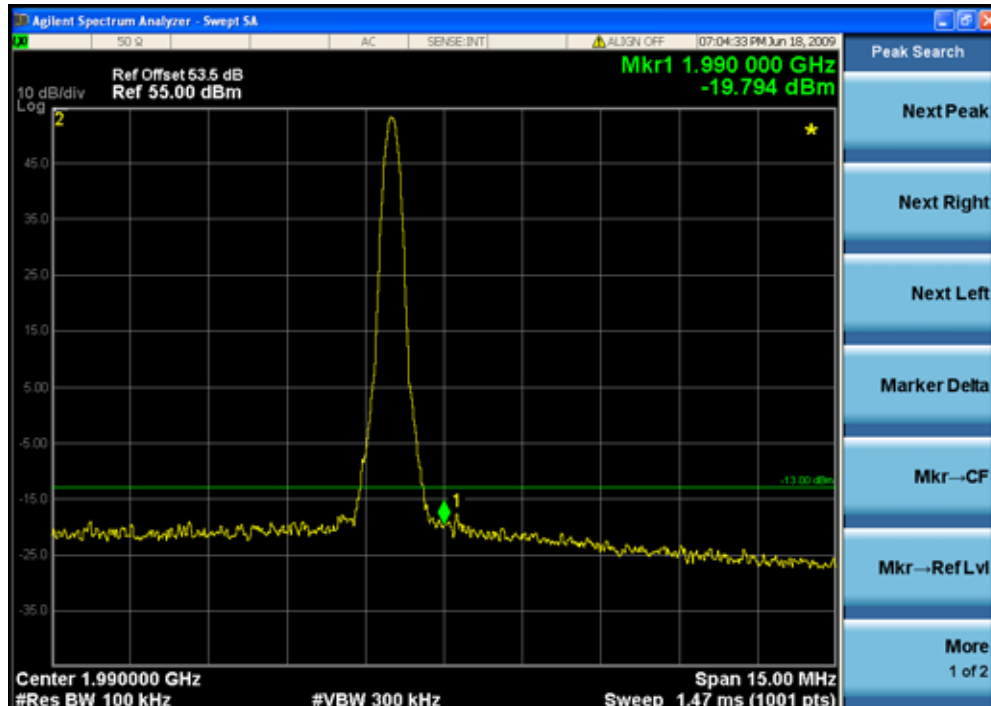



PCS—EDGE two signal input down link—Lower Edge

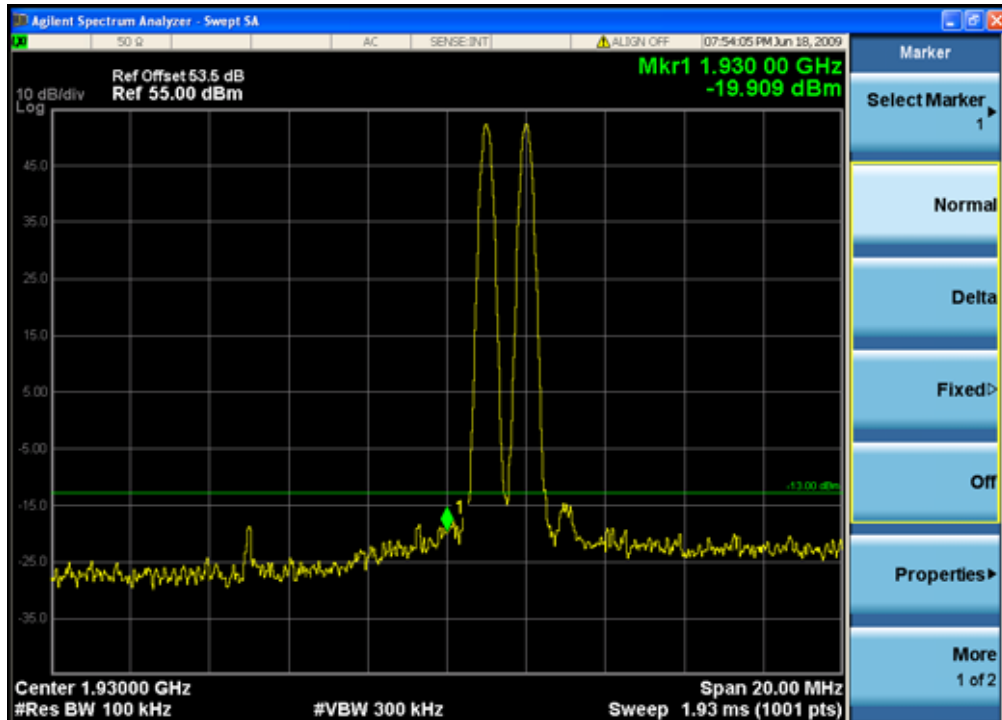

PCS—EDGE two signal input down link—Upper Edge

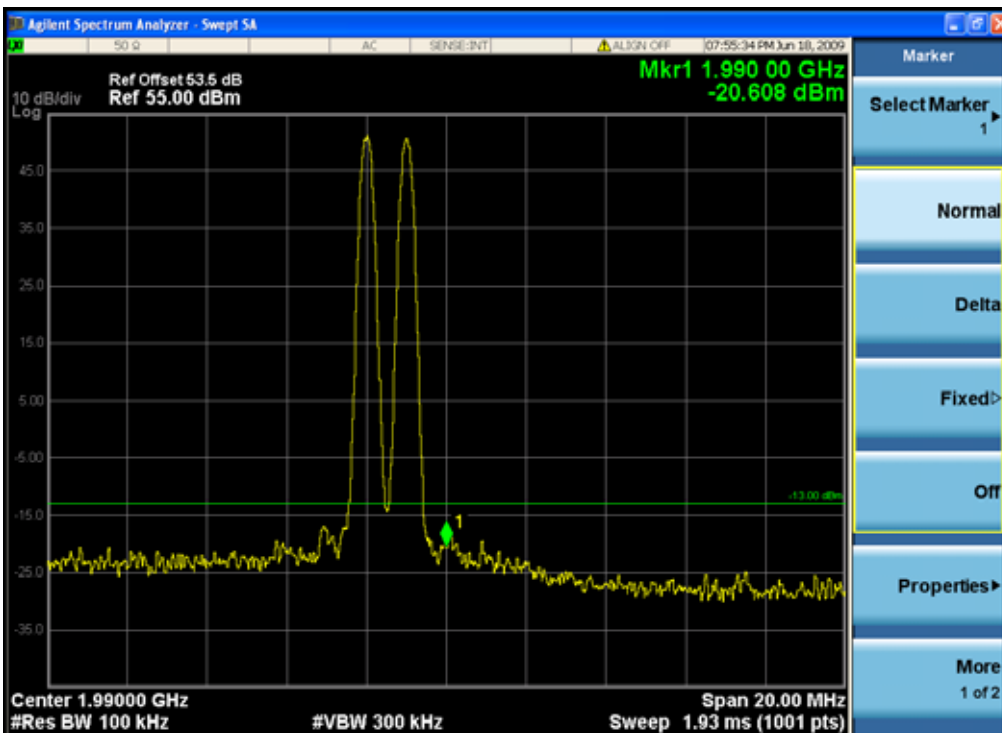



PCS Band

PCS—CDMA one signal input down link—Lower Edge

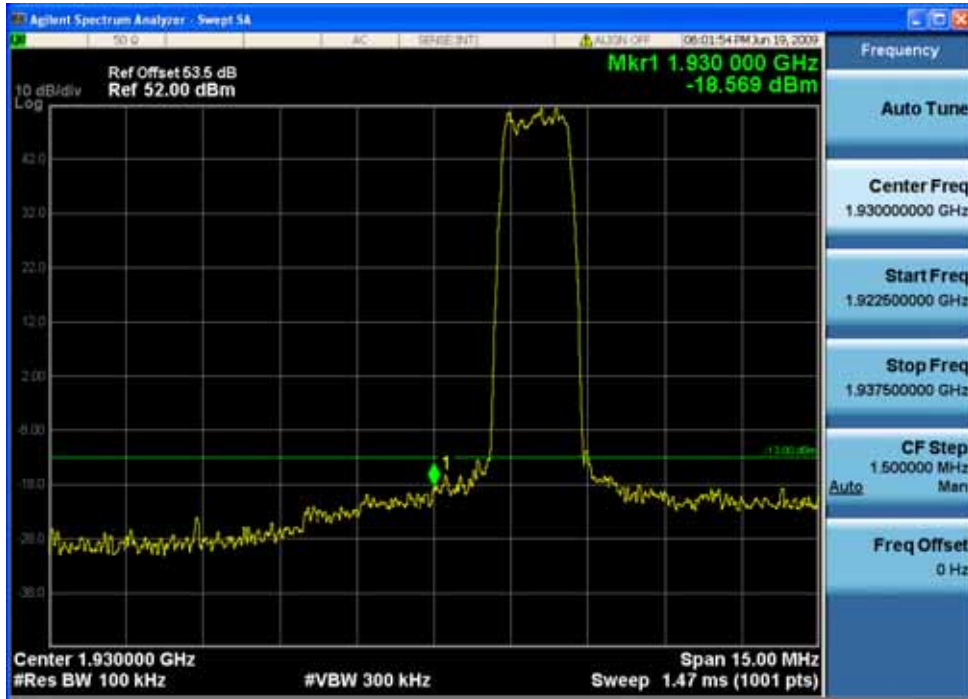

PCS—CDMA one signal input down link—Upper Edge

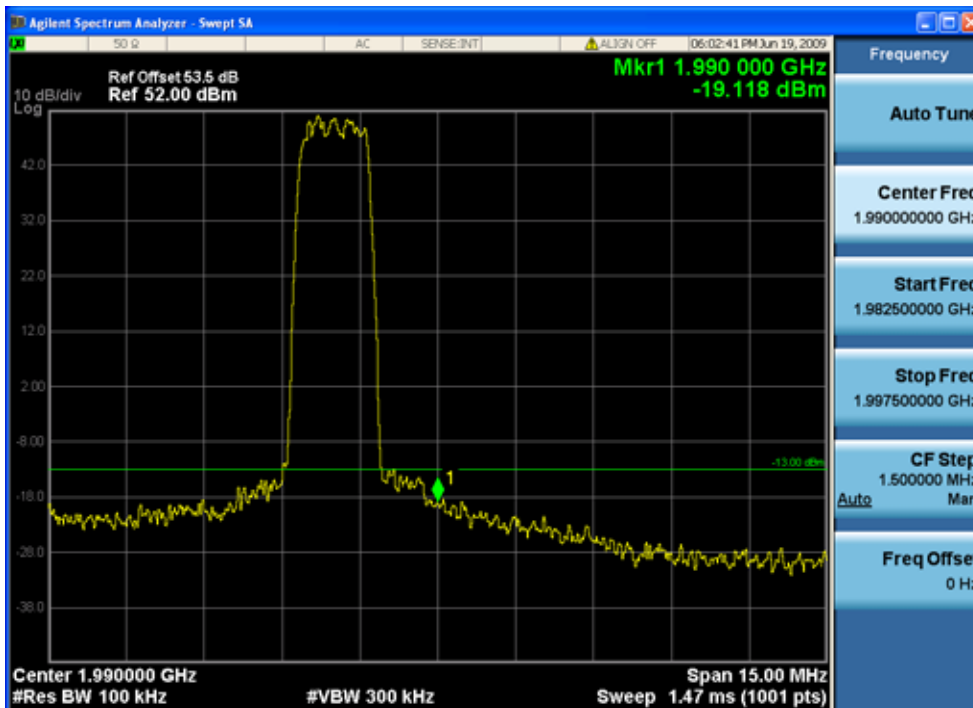



# SGS-CSTC Standards Technical Services Co., Ltd.

Report No.: GLEMO09060172201

Page: 44 of 89

FCC ID: PX8TS-19-12XXXXXX

## PCS—CDMA two signal input down link—Lower Edge

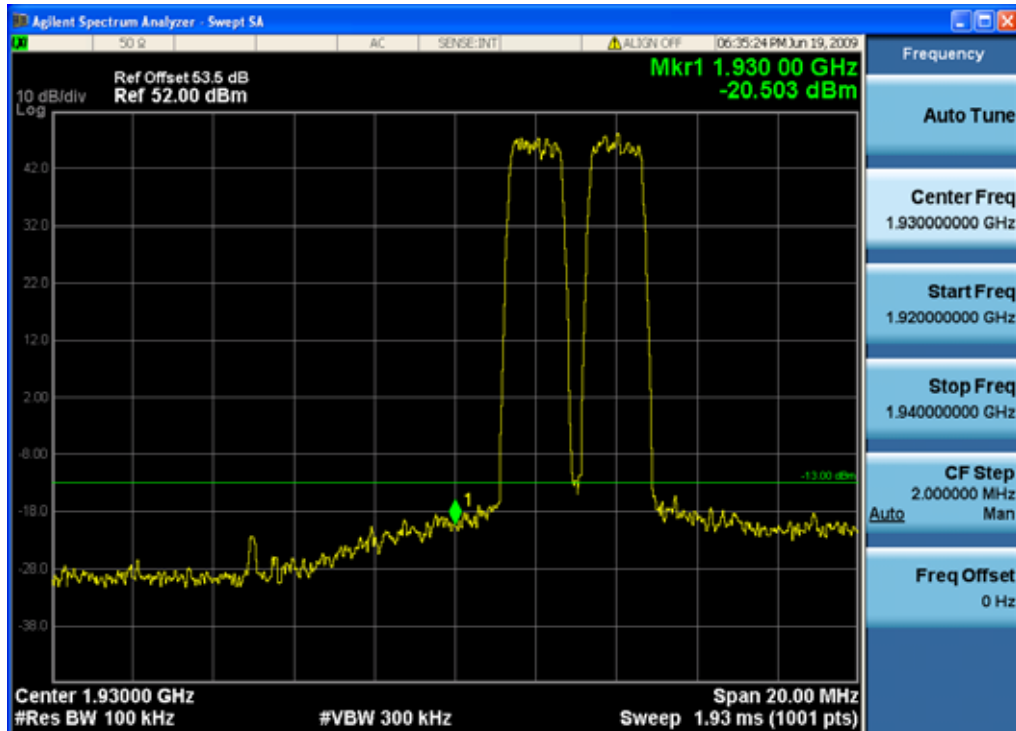

## PCS—CDMA two signal input down link—Upper Edge

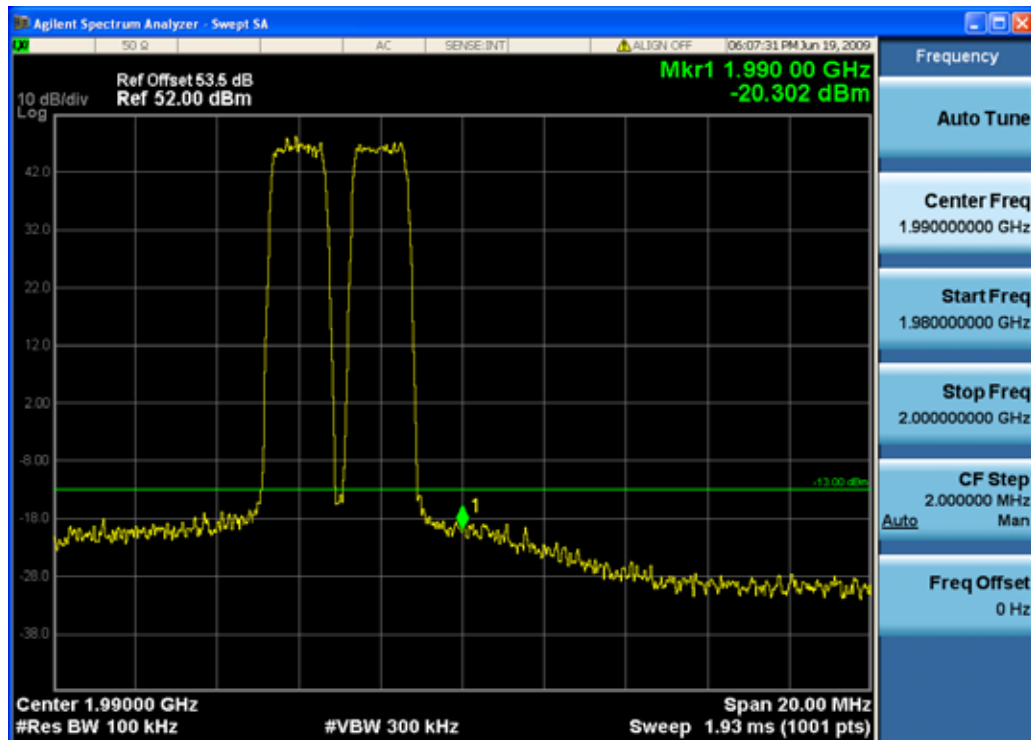



PCS Band

PCS—WCDMA one signal input down link—Lower Edge

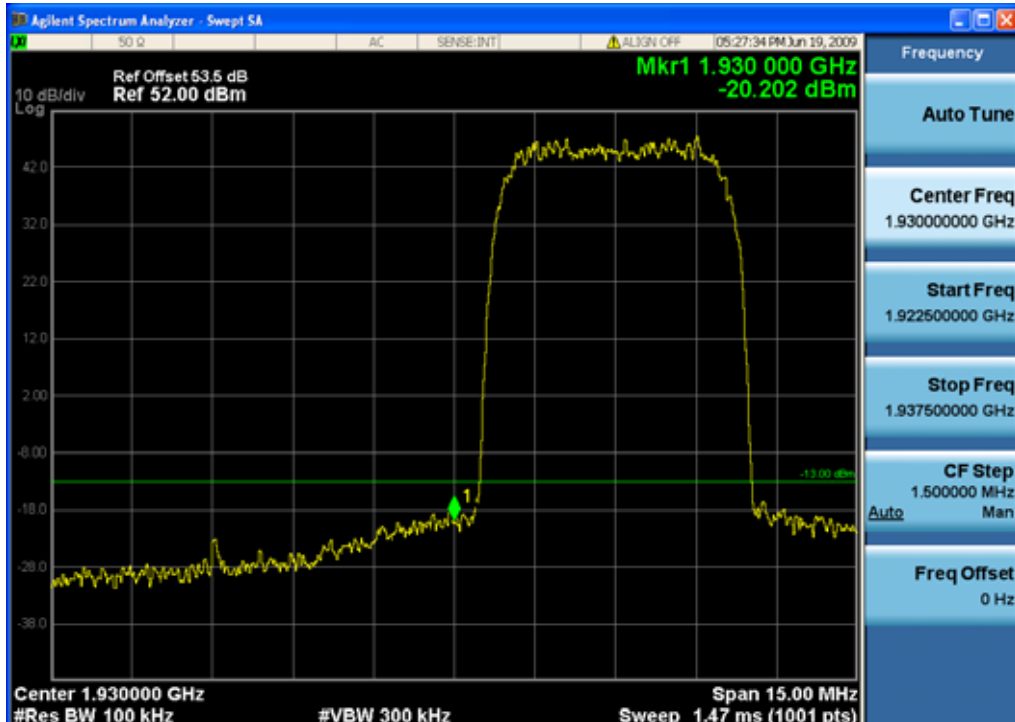

PCS—WCDMA one signal input down link—Upper Edge

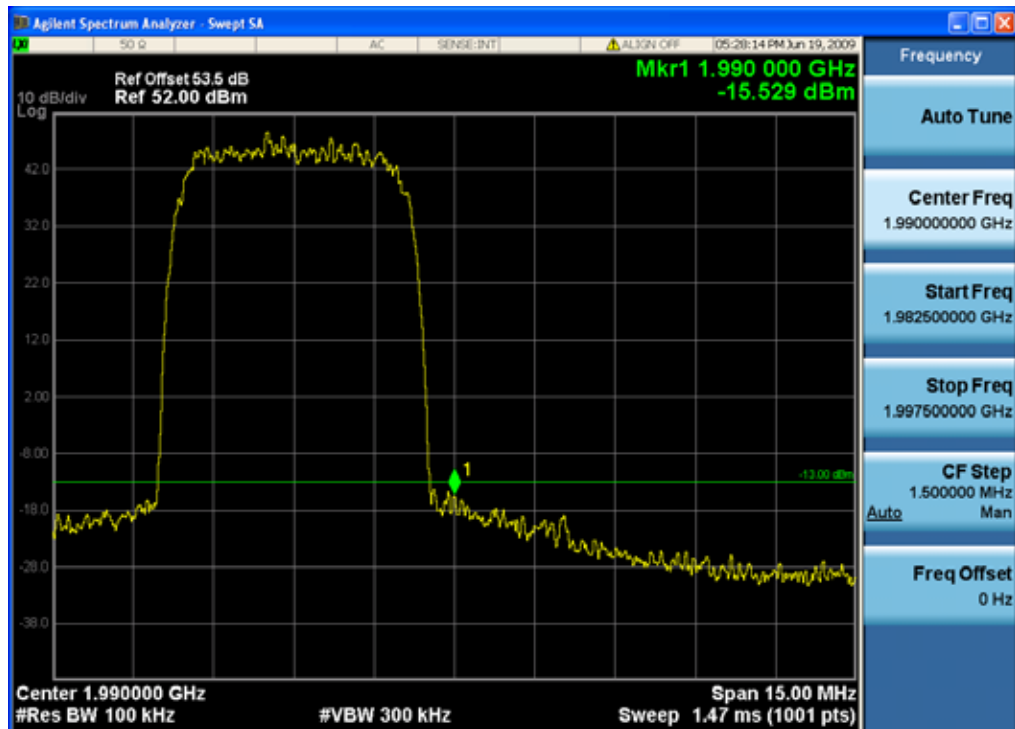



PCS—WCDMA two signal input down link—Lower Edge

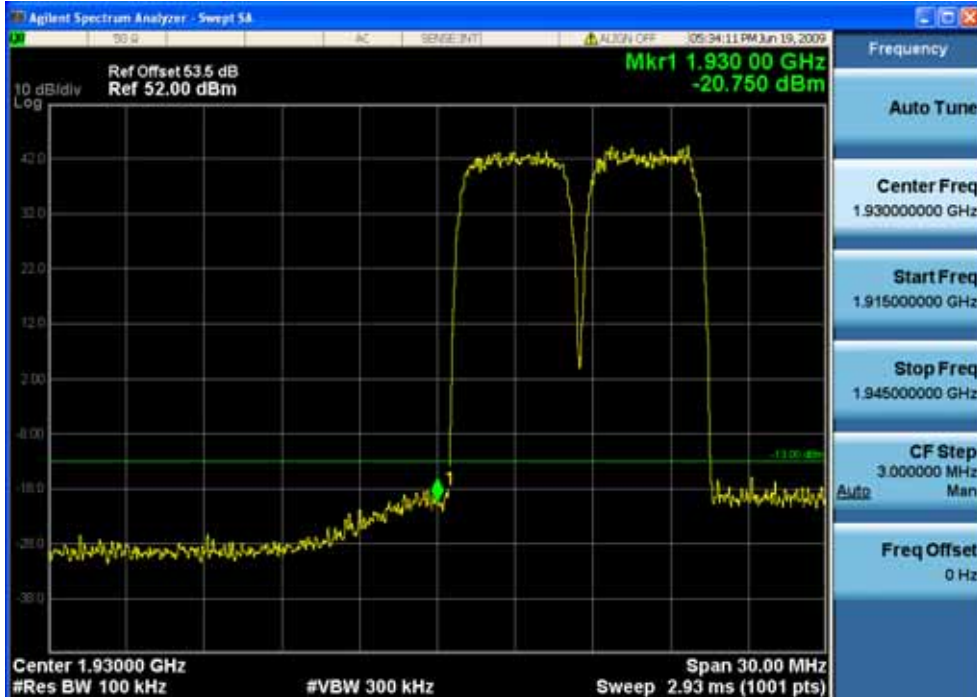

PCS—WCDMA two signal input down link—Upper Edge

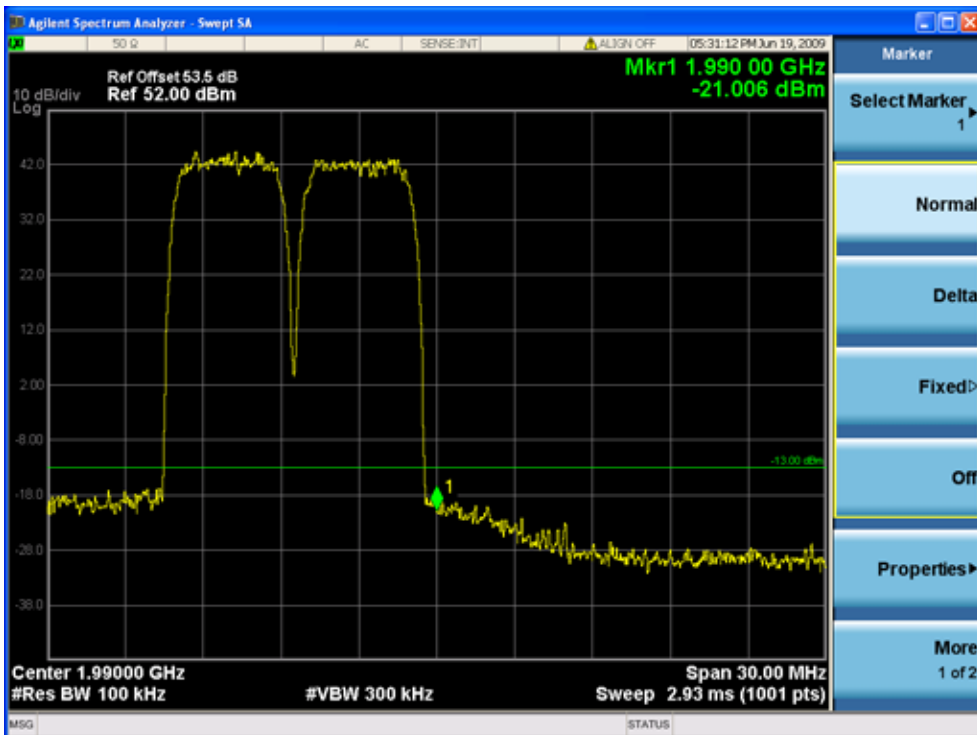



Remark:

For the test in two signal input or intermodulation, test input signal  $f_1$  and  $f_2$  will consider as follows conditions:

- 1) EUT frequency band span and the amount of channels;
- 2)  $f_1$  is the frequency lower,  $f_2$  is the frequency higher,  $f$  is the channel spacing;
- 3) in lower edge test,  $f_1$  is the lower edge frequency +1 channel frequency, and  $f_2$  is +2 channel frequency;
- 4) in higher edge test,  $f_1$  is the higher edge frequency -2 channel frequency, and  $f_2$  is -1 channel frequency;
- 5) according to the amplifier characteristic, the 3<sup>rd</sup> product will appear when two signals input;
- 6) base the 3<sup>rd</sup> product frequency  $F_1 = 2f_1 - f_2$  and  $F_2 = 2f_2 - f_1$ , when the  $f_1$  and  $f_2$  frequency select above,
  - a) in lower edge test,  $F_1 = 2f_1 - (f_1 + f) = f_1 - f =$  lower edge frequency;
  - b) in higher edge test,  $F_2 = 2f_2 - (f_2 - f) = f_2 + f =$  higher edge frequency.

### 7.2.4 Radiated Spurious Emissions

Test Date: 17 to 19 June 2009

Test Requirement: FCC part 24.238(a)

24.238(a) Out of band emissions. The power of any emission outside of the authorized operating frequency ranges must be attenuated below the transmitting power (P) by a factor of at least  $43 + 10 \log(P)$  dB.

Test Method: FCC part 2.1053

EUT Operation:

Status: The output power of EUT be set to maximum value.

Conditions: Normal conditions

Application: Enclosure

Test Configuration:

30MHz to 1GHz:

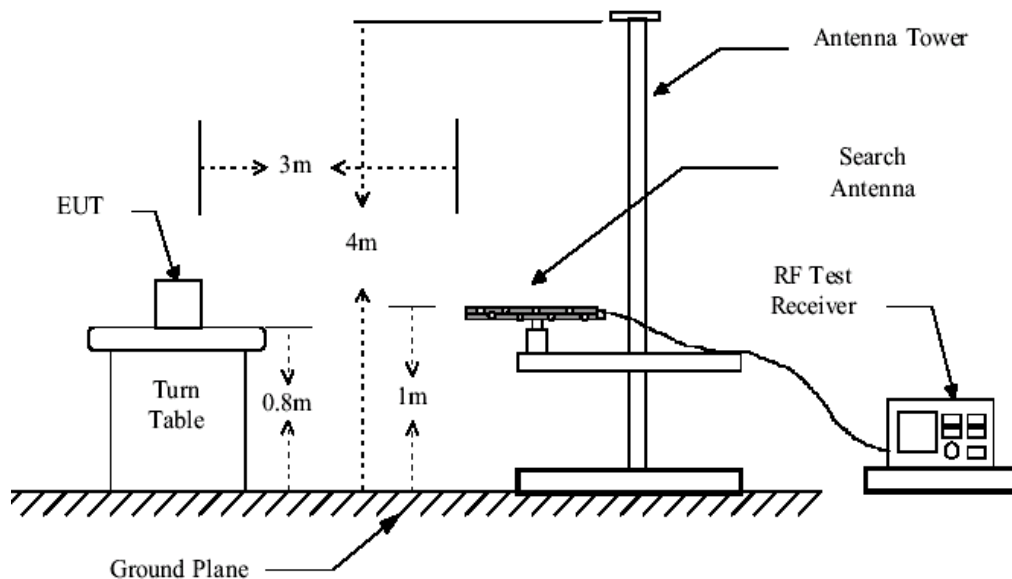



Above 1GHz:

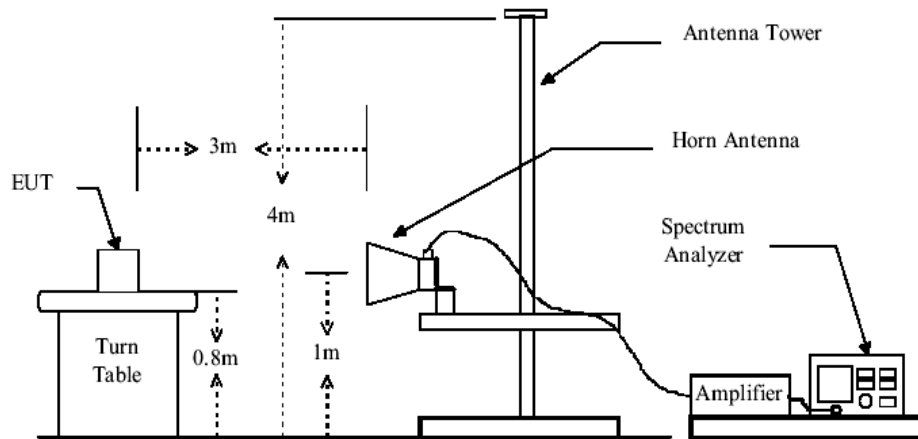

Test Procedure:

1. Test the background noise level with all the test facilities;
2. Keep one transmitting path, all other connectors shall be connected by normal power or RF leads;
3. Select the suitable RF notch filter to avoid the test receiver or spectrum analyzer produce unwanted spurious emissions;
4. Keep the EUT continuously transmitting in max power;
5. Read the radiated emissions of the EUT enclosure.

Radiated Emissions Test Procedure:

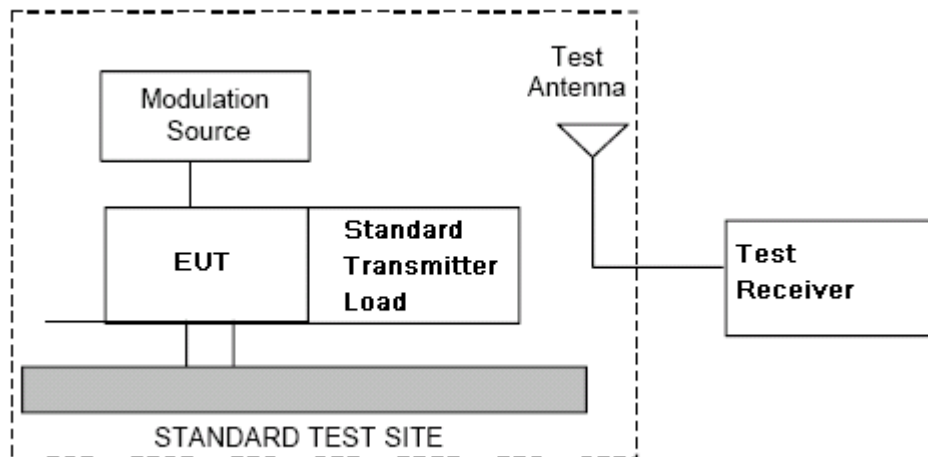

- a) Connect the equipment as illustrated.
- b) Adjust the spectrum analyzer for the following settings:
  - 1) Resolution Bandwidth = 100 kHz for spurious emissions below 1 GHz, and 1 MHz for spurious emissions above 1GHz.
  - 2) Video Bandwidth = 300 kHz for spurious emissions below 1 GHz, and 3 MHz for spurious emissions above 1 GHz.
  - 3) Sweep Speed slow enough to maintain measurement calibration.
  - 4) Detector Mode = Positive Peak.
- c) Place the transmitter to be tested on the turntable in the standard test site, The transmitter is transmitting into a nonradiating load that is placed on the turntable. The RF cable to this load should be of minimum length.
- d) Measurements shall be made from 30MHz to 10 times of fundamental carrier, except for the region close to the carrier equal to  $\pm$  the carrier bandwidth.
- e) Key the transmitter without modulation or normal modulation base the standard.
- f) For each spurious frequency, raise and lower the test antenna from 1 m to 4 m to obtain a maximum reading on the spectrum analyzer with the test antenna at horizontal polarity. Then the turntable should be rotated 360° to determine the maximum reading. Repeat this procedure to obtain the highest possible reading. Record this maximum reading.
- g) Repeat step f) for each spurious frequency with the test antenna polarized vertically.

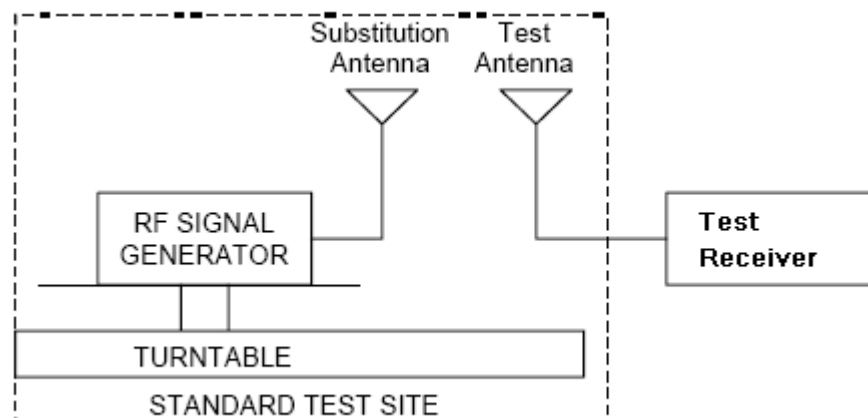



- h) Reconnect the equipment as illustrated.
- i) Keep the spectrum analyzer adjusted as in step b).
- j) Remove the transmitter and replace it with a substitution antenna (the antenna should be half-wavelength for each frequency involved). The center of the substitution antenna should be approximately at the same location as the center of the transmitter. At the lower frequencies, where the substitution antenna is very long, this will be impossible to achieve when the antenna is polarized vertically. In such case the lower end of the antenna should be 0.3 m above the ground.
- k) Feed the substitution antenna at the transmitter end with a signal generator connected to the antenna by means of a nonradiating cable. With the antennas at both ends horizontally polarized, and with the signal generator tuned to a particular spurious frequency, raise and lower the test antenna to

obtain a maximum reading at the spectrum analyzer. Adjust the level of the signal generator output until the previously recorded maximum reading for this set of conditions is obtained. This should be done carefully repeating the adjustment of the test antenna and generator output.

- l) Repeat step k) with both antennas vertically polarized for each spurious frequency.
- m) Calculate power in dBm into a reference ideal half-wave dipole antenna by reducing the readings obtained in steps k) and l) by the power loss in the cable between the generator and the antenna, and further corrected for the gain of the substitution antenna used relative to an ideal half-wave dipole

antenna by the following formula:

$$Pd(\text{dBm}) = Pg(\text{dBm}) - \text{cable loss (dB)} + \text{antenna gain (dB)}$$

where:

$Pd$  is the dipole equivalent power and

$Pg$  is the generator output power into the substitution antenna.

NOTE: It is permissible to use other antennas provided they can be referenced to a dipole.

NOTE: Effective radiated power (e.r.p) refers to the radiation of a half wave tuned dipole instead of an isotropic antenna. There is a constant difference of 2.15 dB between e.i.r.p. and e.r.p.

$$\text{e.r.p (dBm)} = \text{e.i.r.p. (dBm)} - 2.15$$



7.2.4.1 Measurement Record:

| Test Frequency (MHz) | Measuring Level (dBm) |            | Limits (dBm) | Margin (dB) |            |
|----------------------|-----------------------|------------|--------------|-------------|------------|
|                      | Vertical              | Horizontal |              | Vertical    | Horizontal |
| 30                   | N/A                   | N/A        | -13.0        | N/A         | N/A        |
| 500                  | N/A                   | N/A        | -13.0        | N/A         | N/A        |
| 1000                 | N/A                   | N/A        | -13.0        | N/A         | N/A        |
| 2000                 | N/A                   | N/A        | -13.0        | N/A         | N/A        |
| 5000                 | N/A                   | N/A        | -13.0        | N/A         | N/A        |
| 10000                | N/A                   | N/A        | -13.0        | N/A         | N/A        |
| 15000                | N/A                   | N/A        | -13.0        | N/A         | N/A        |
| 20000                | N/A                   | N/A        | -13.0        | N/A         | N/A        |

Remark:

N/A,not applicable or the level is too weak to be detected.

Pretest the N+1 system and 4 in 4 out system and 4x2 1 sector system, do not found any obvious emission.

According to the model difference description before, the 4x2 3 sector system is three 4x2 1 sector system physical add together.So test the 4x2 system 1 sector system to judge 3 sector system emissions.

Sweep all the modulation types emissions in Cellular band, find the worse case to report it.

### 7.2.5 Occupied Bandwidth

Test Date: 17 to 19 June 2009

Test Requirement: 2-11-04/EAB/RF

Test Method: FCC part 2.1049, 2-11-04/EAB/RF

The spectral shape of the output should look similar to input for all modulations.

EUT Operation:

Status: The output power of EUT be set to maximum value.

Conditions: Normal conditions

Application: PCS Band RF output ports

Test Configuration:

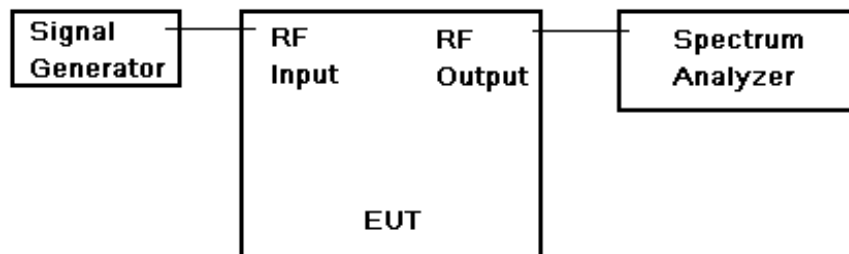

Fig.2. Conducted Spurious Emissions test configuration

Test Procedure:

- a) Set the spectrum analyzer RBW 300 Hz or  $>1\% & < 2\%$  emission bandwidth of carrier.
- b) Capture the trace of input signal;
- c) Connect the equipment as illustrated;
- b) Capture the trace of output signal;

**7.2.5.1 Measurement Record:**

**N+1, 4 in 4 out system**

**PCS Band**

PCS—TDMA down link(lowest frequency)—Input

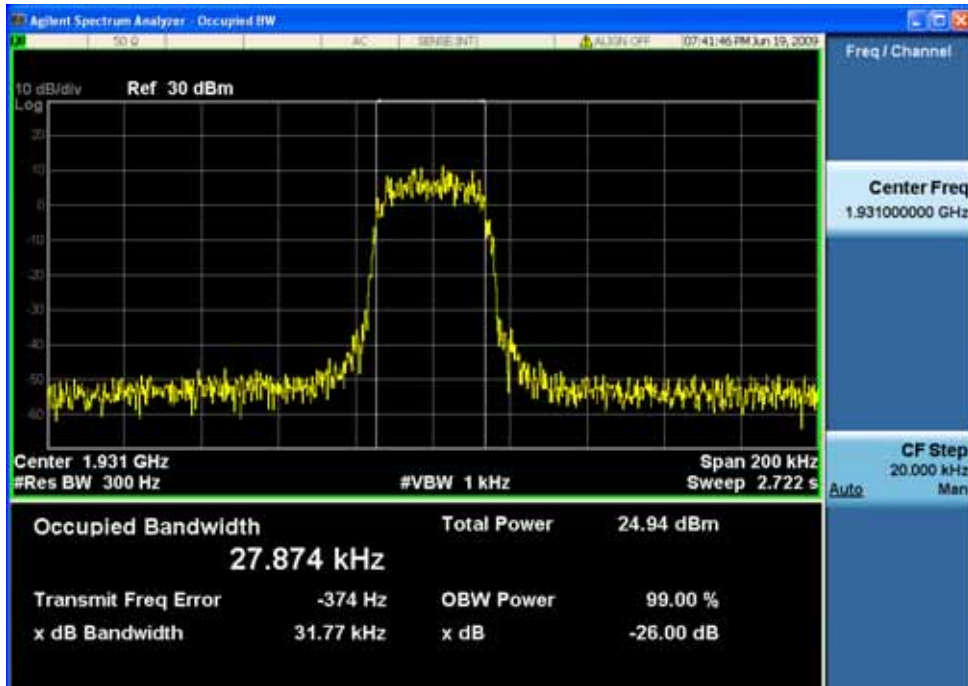

PCS—TDMA down link(lowest frequency)—Output

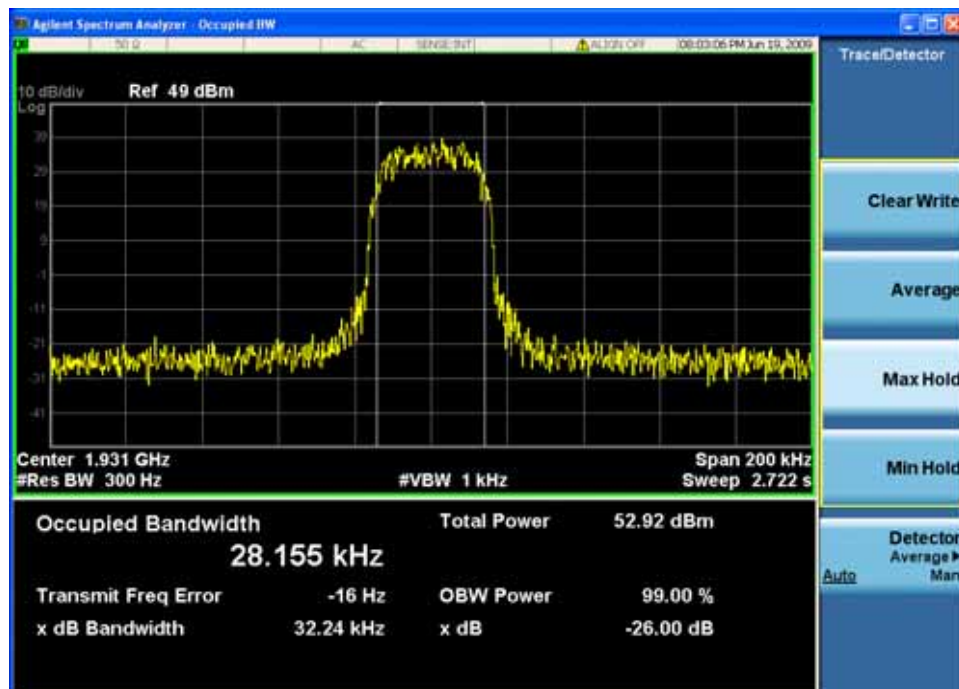



PCS—TDMA down link(middle frequency)—Input

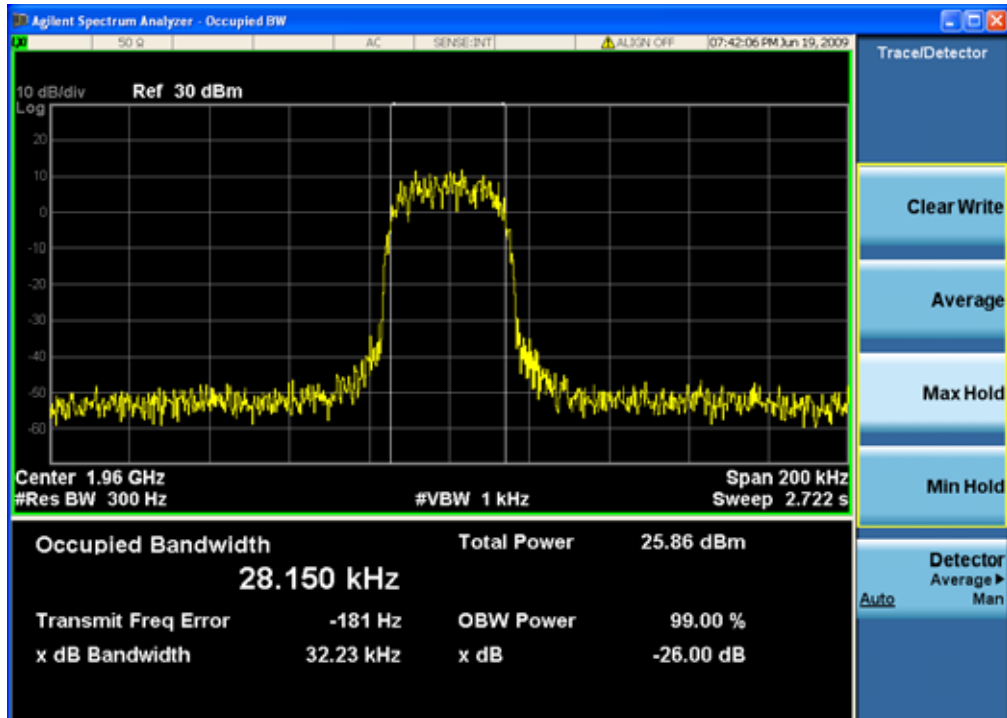

PCS—TDMA down link(middle frequency)--Output

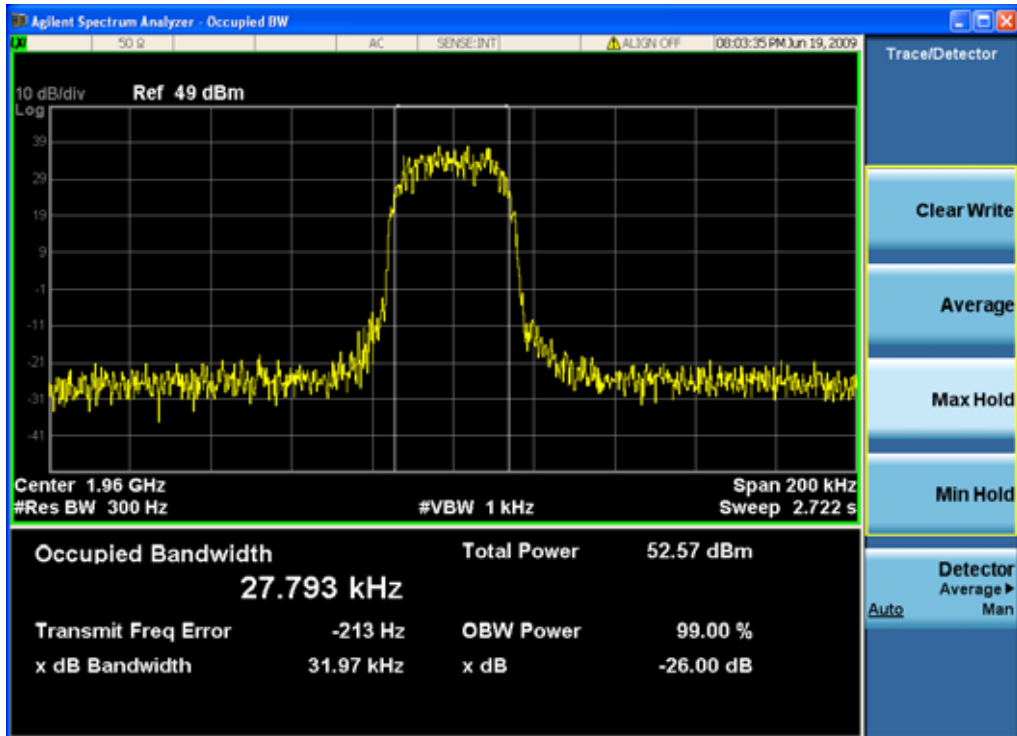



PCS—TDMA down link(highest frequency)—Input

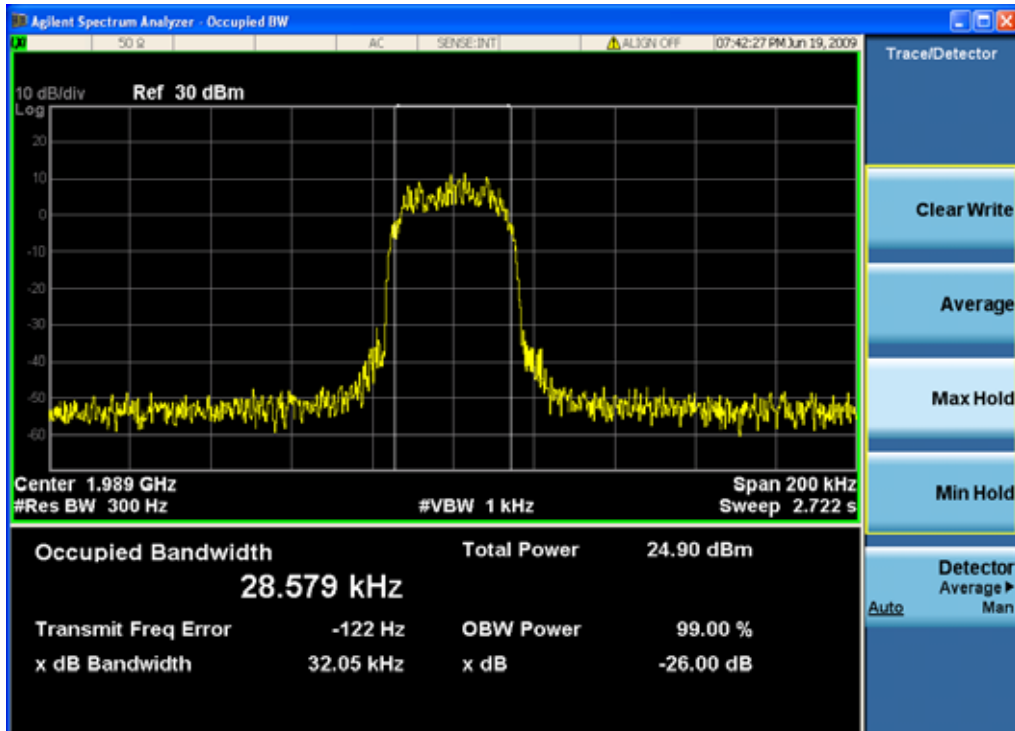

PCS—TDMA down link(highest frequency)--Output

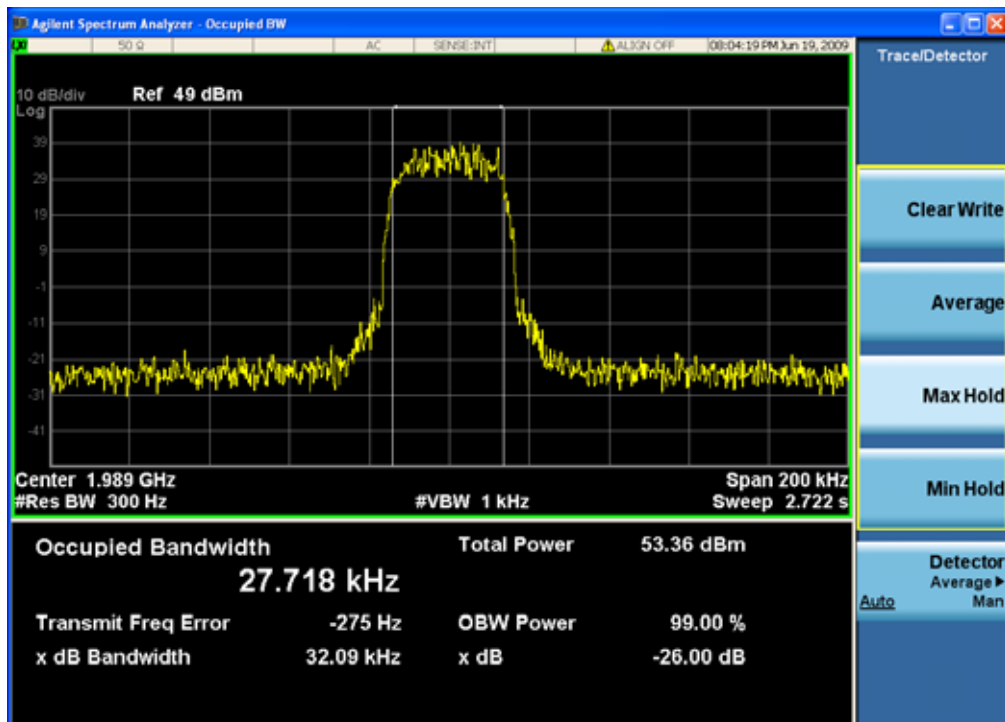





PCS Band

PCS—GSM down link(lowest frequency)—Input

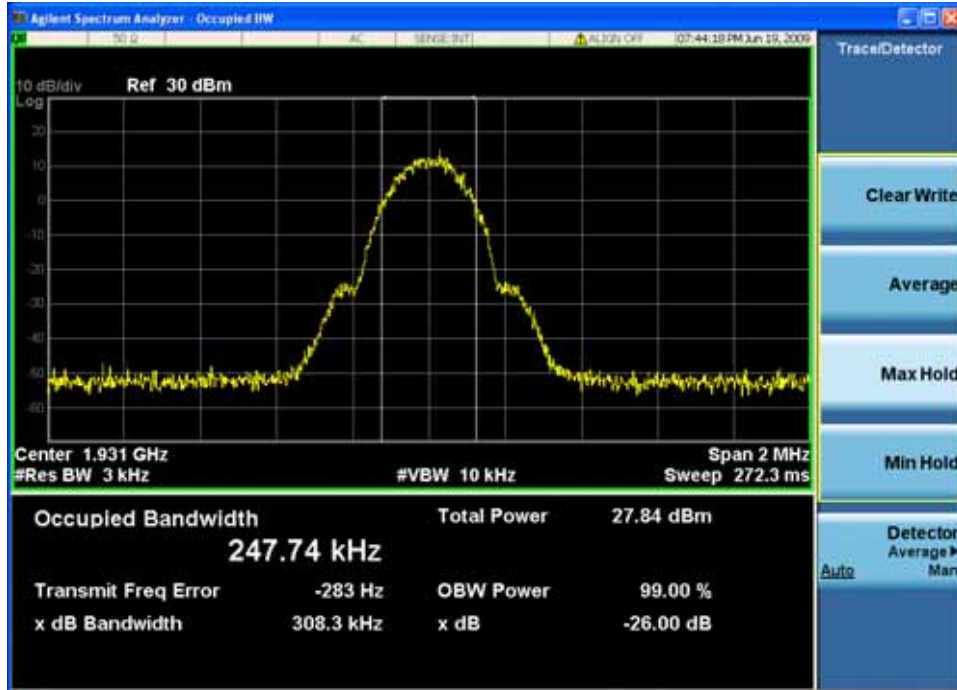

PCS—GSM down link(lowest frequency)—Output

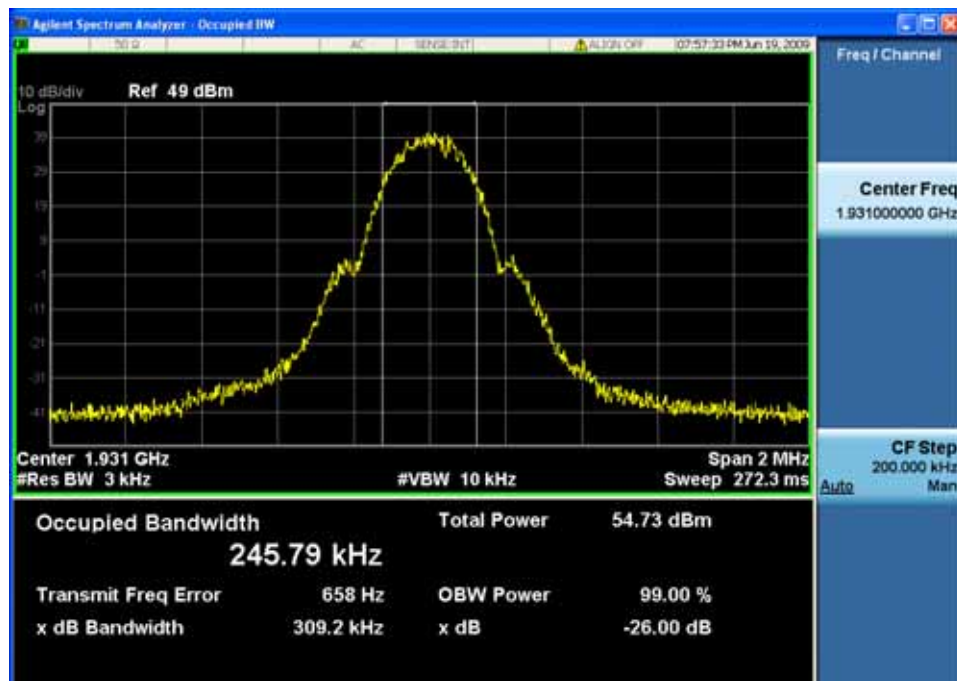



PCS—GSM down link(middle frequency)—Input

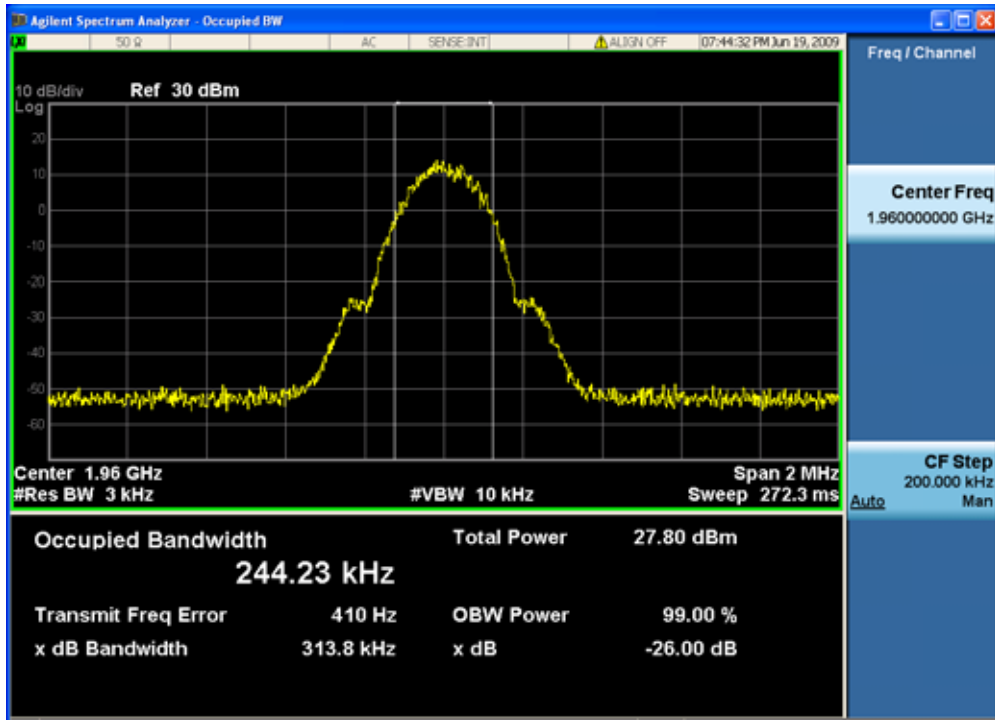

PCS—GSM down link(middle frequency)—Output

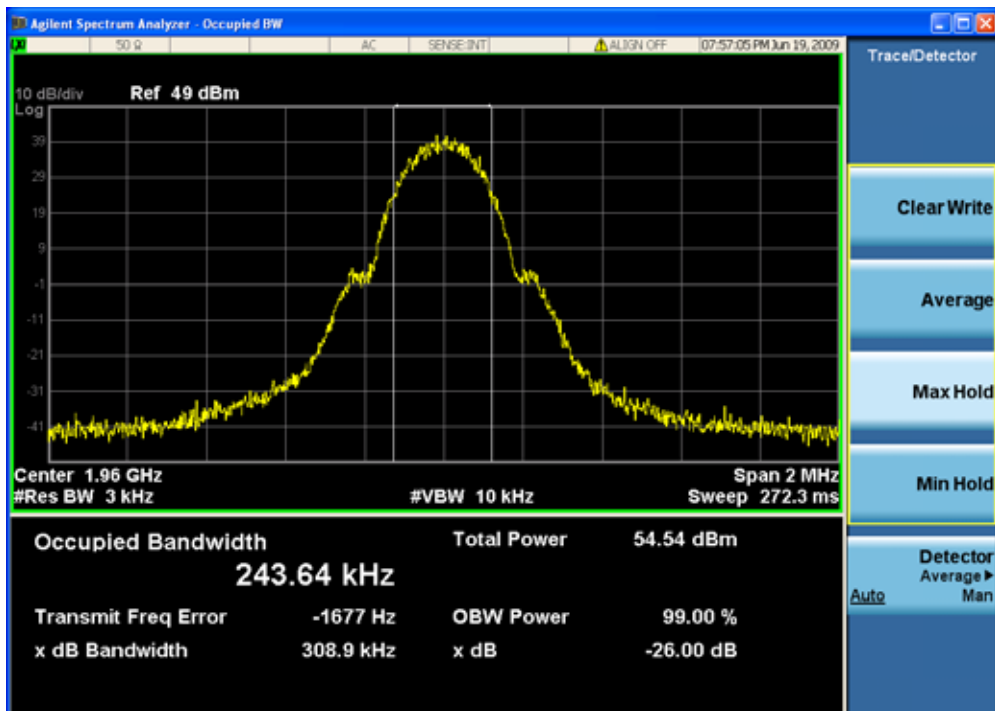



PCS—GSM down link(highest frequency)—Input

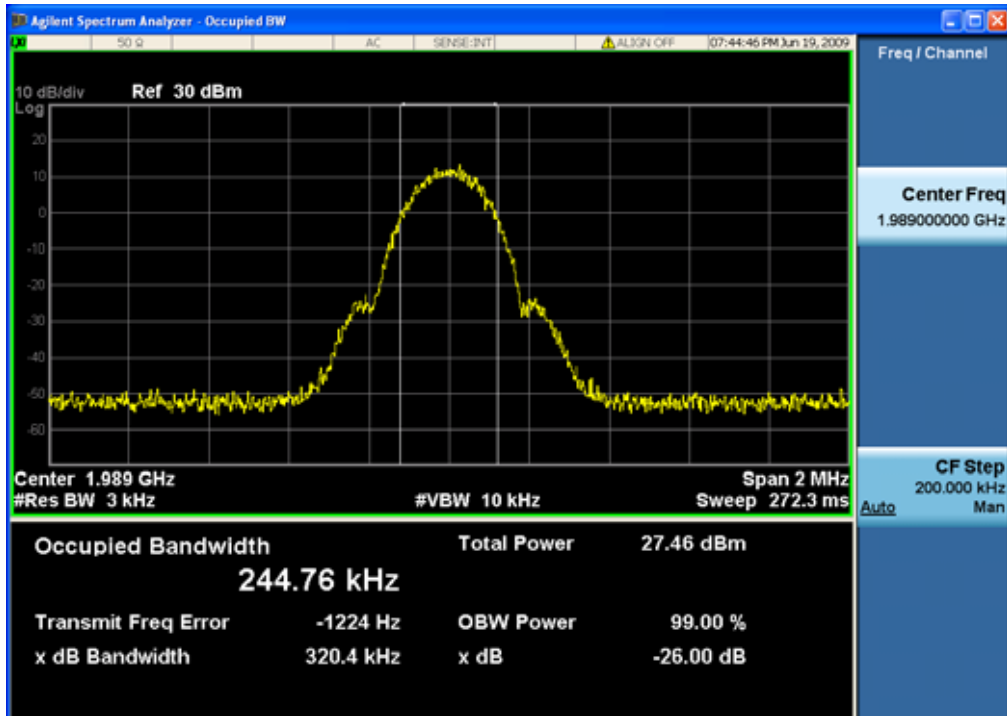

PCS—GSM down link(highest frequency)--Output

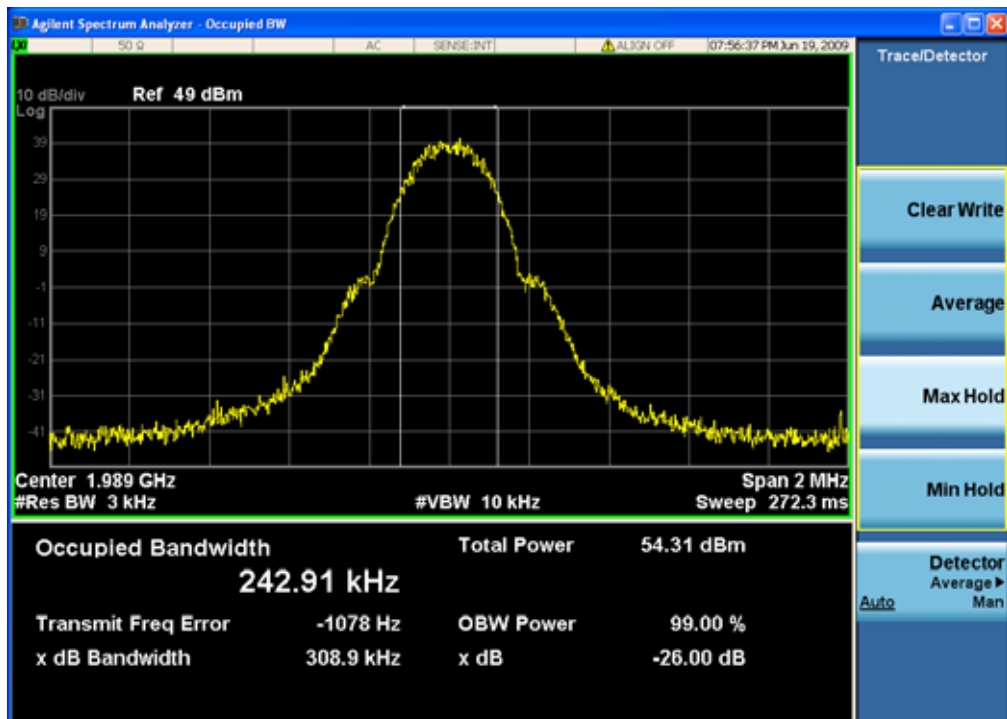



PCS Band

PCS—EDGE down link(lowest frequency)—Input

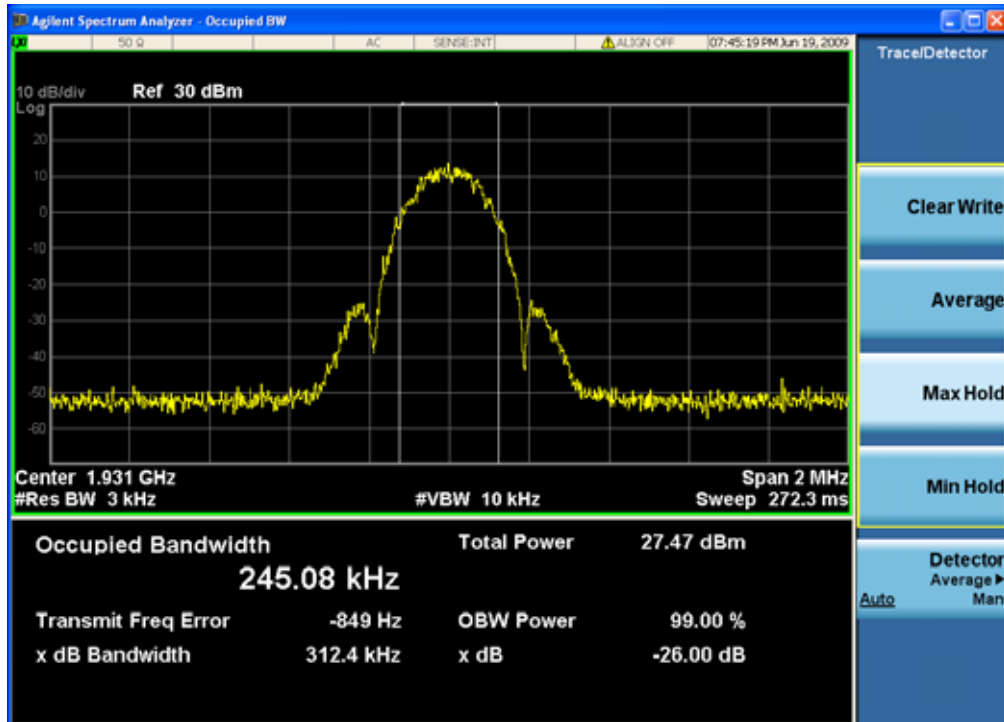

PCS—EDGE down link(lowest frequency)—Output

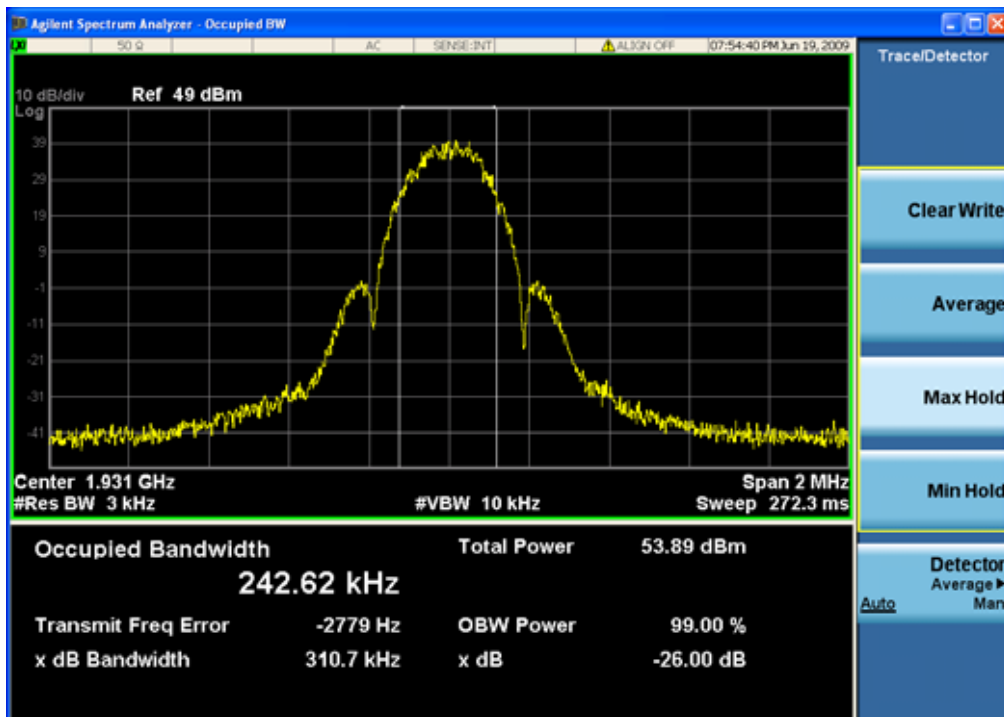

PCS—EDGE down link(middle frequency)—Input

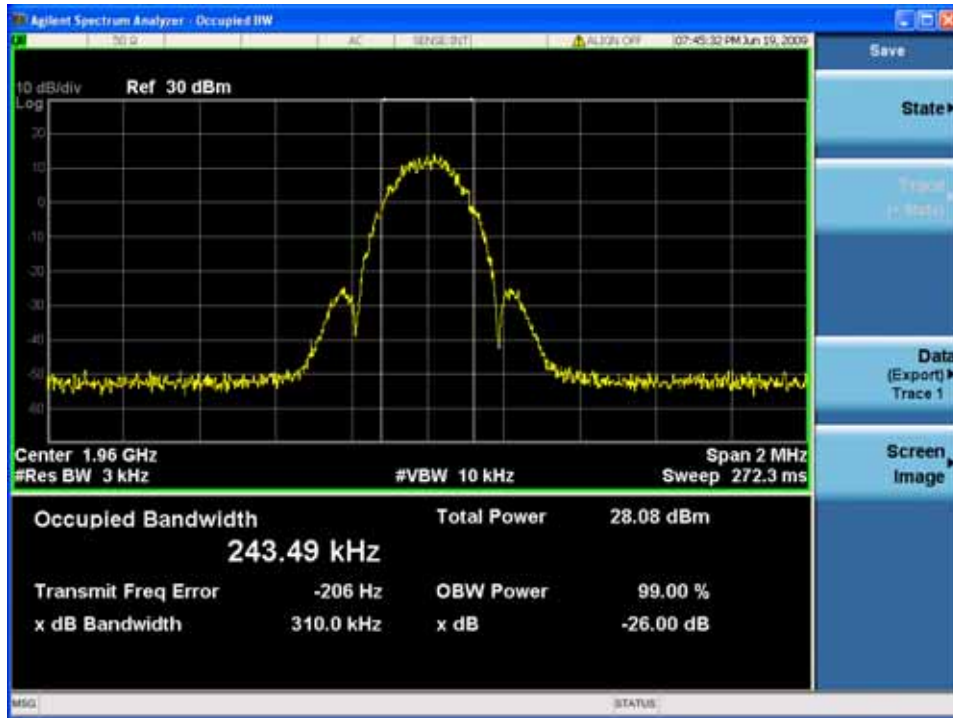

PCS—EDGE down link(middle frequency)—Output

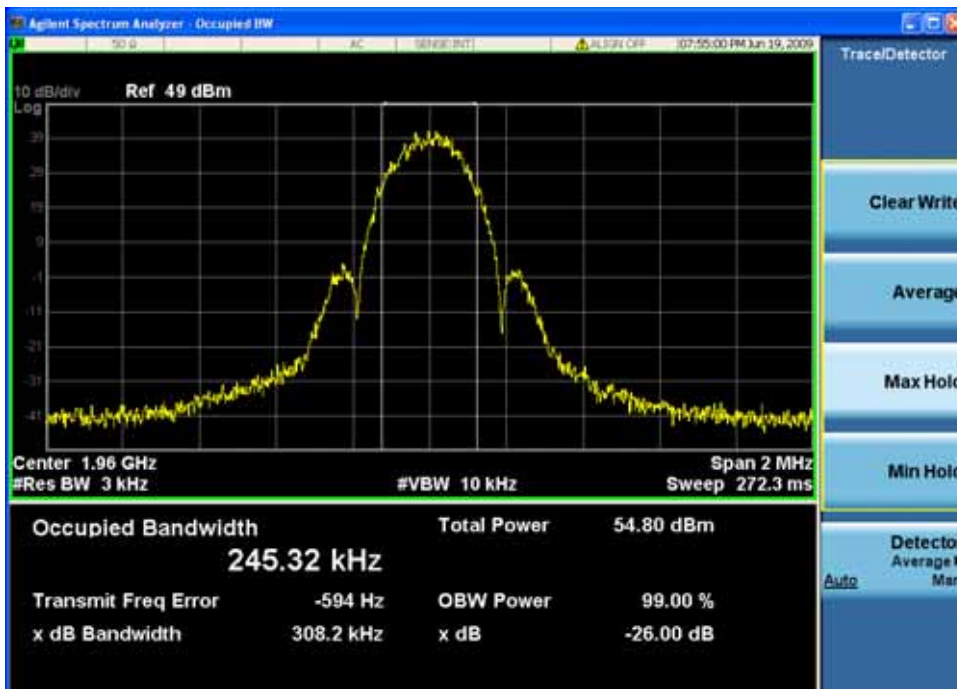



PCS—EDGE down link(highest frequency)—Input

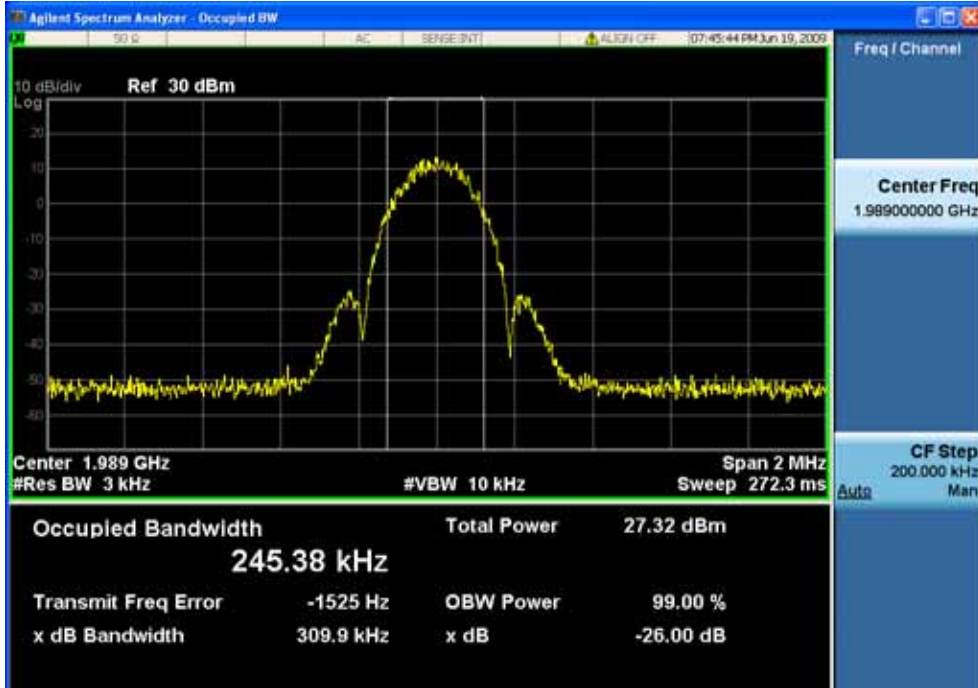

PCS—EDGE down link(highest frequency)--Output

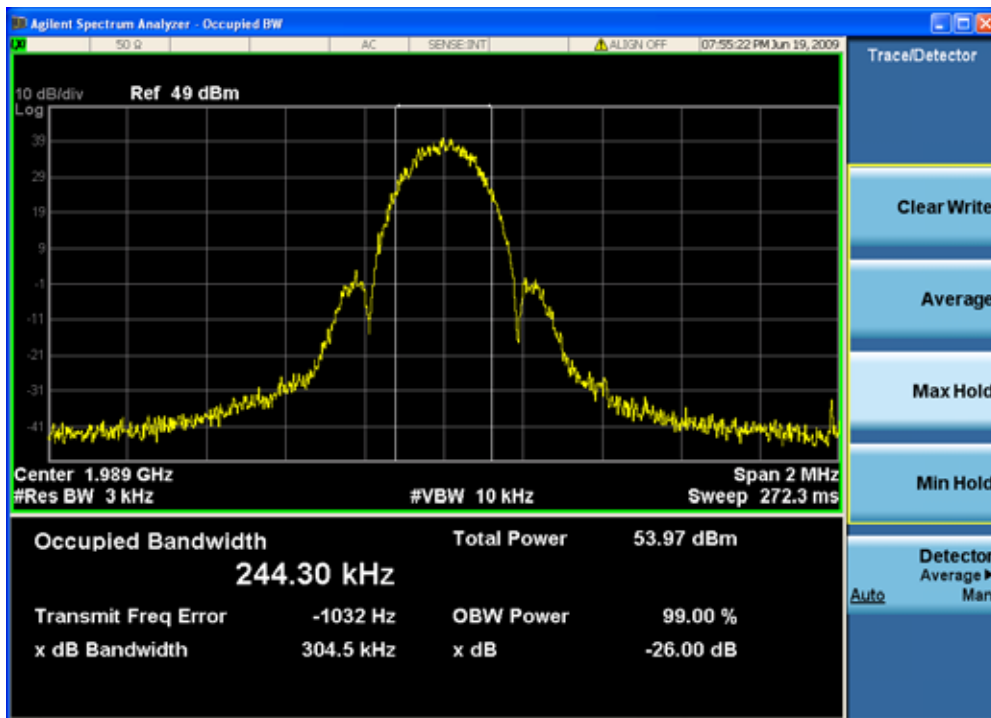



PCS Band

PCS—CDMA down link(lowest frequency)—Input

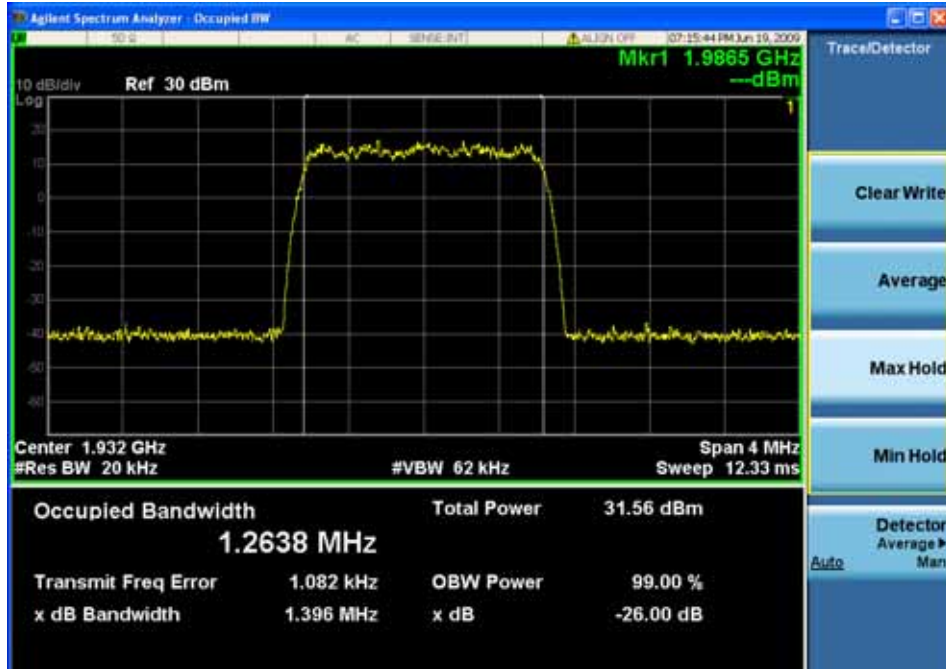

PCS—CDMA down link(lowest frequency)--Output

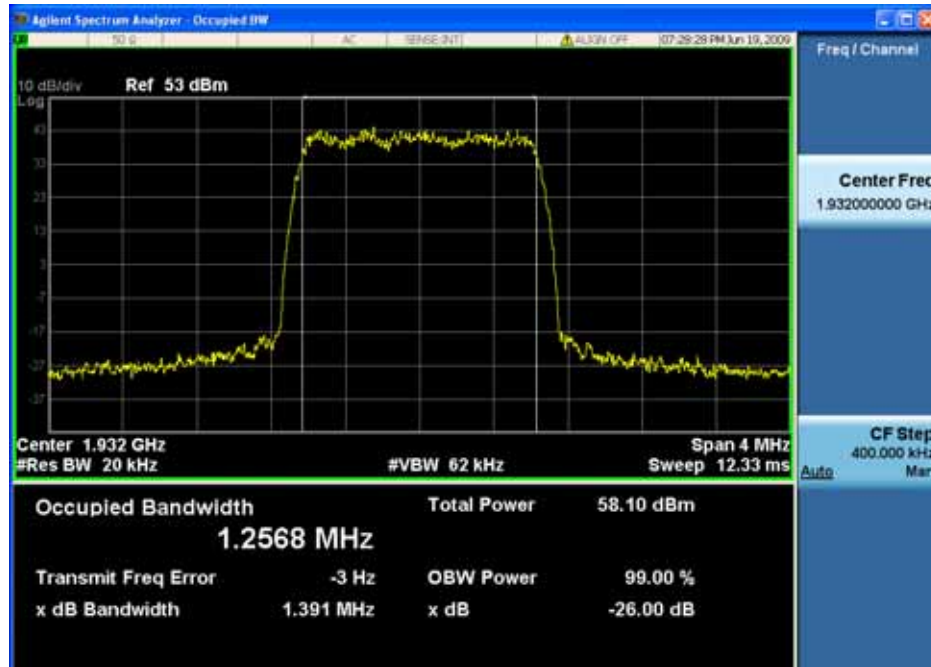



PCS—CDMA down link(middle frequency)—Input

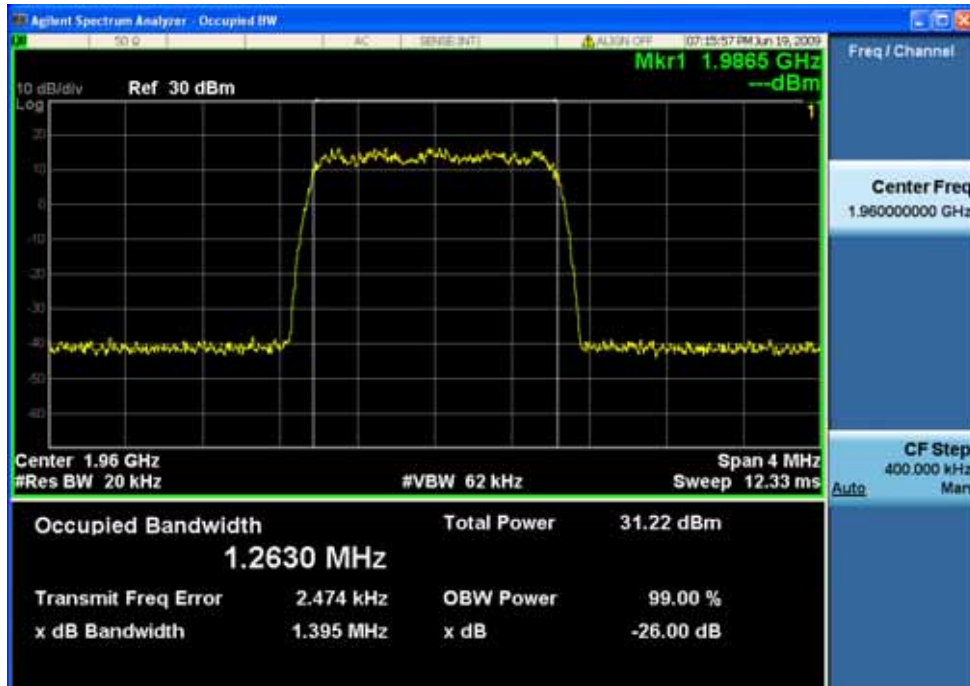

PCS—CDMA down link(middle frequency)--Output

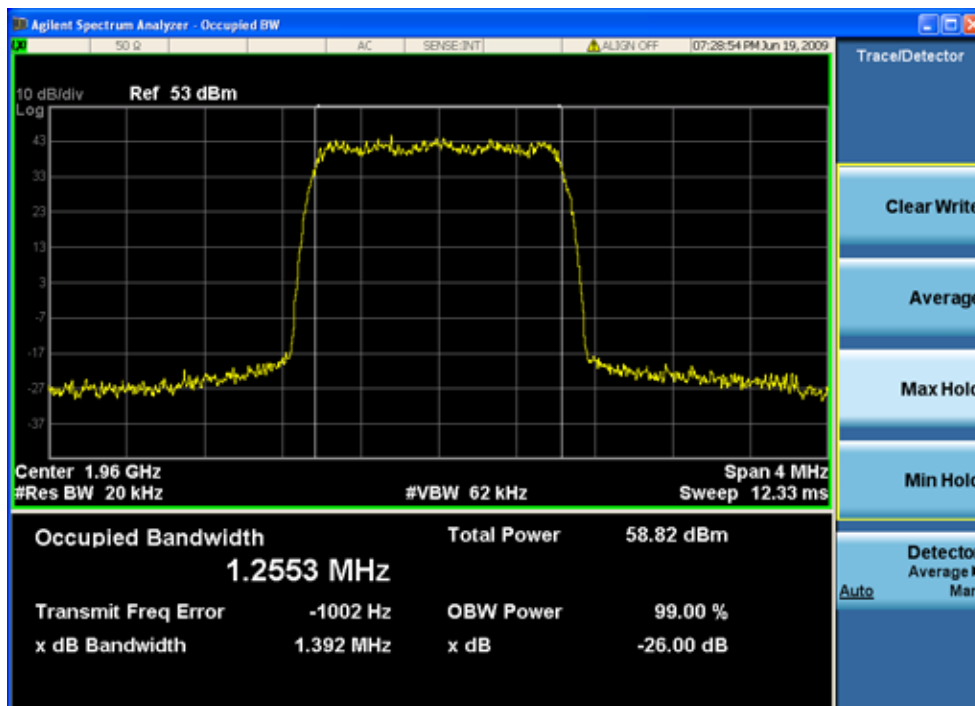



PCS—CDMA down link(highest frequency)—Input

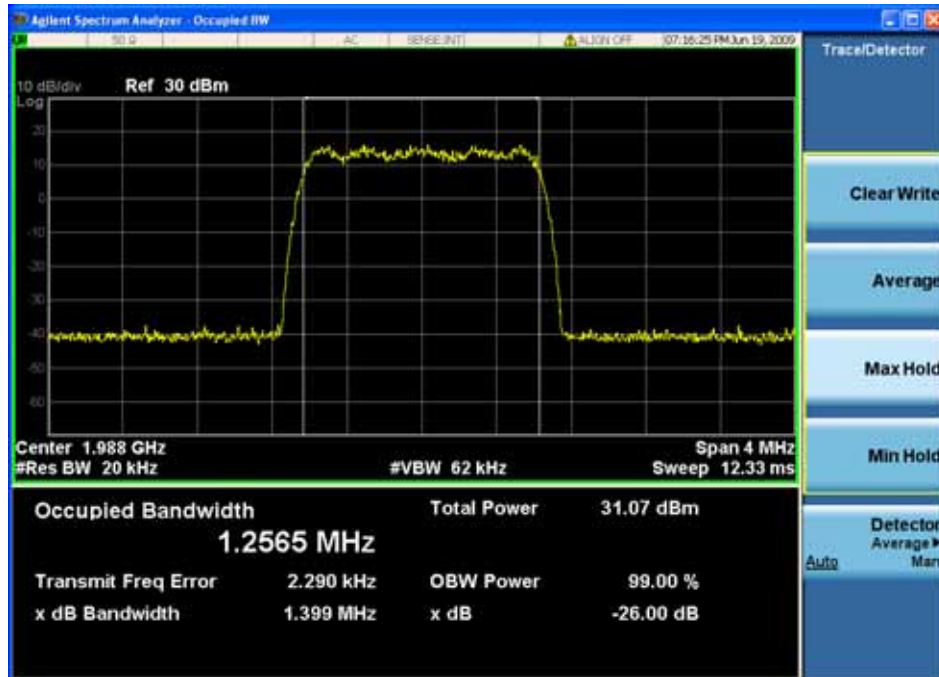

PCS—CDMA down link(highest frequency)--Output

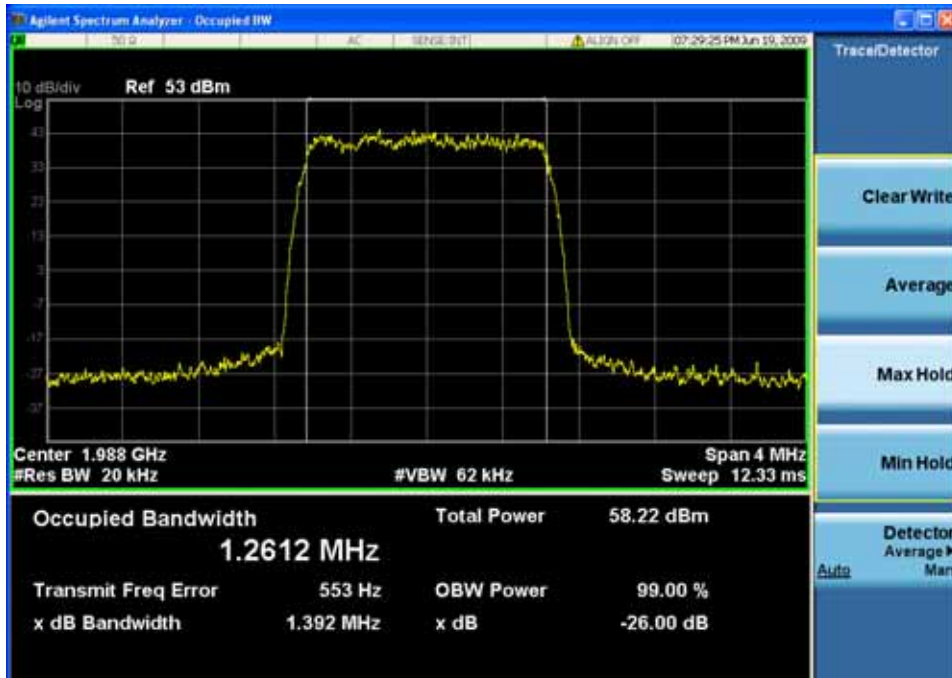



PCS Band

PCS—WCDMA down link(lowest frequency)—Input

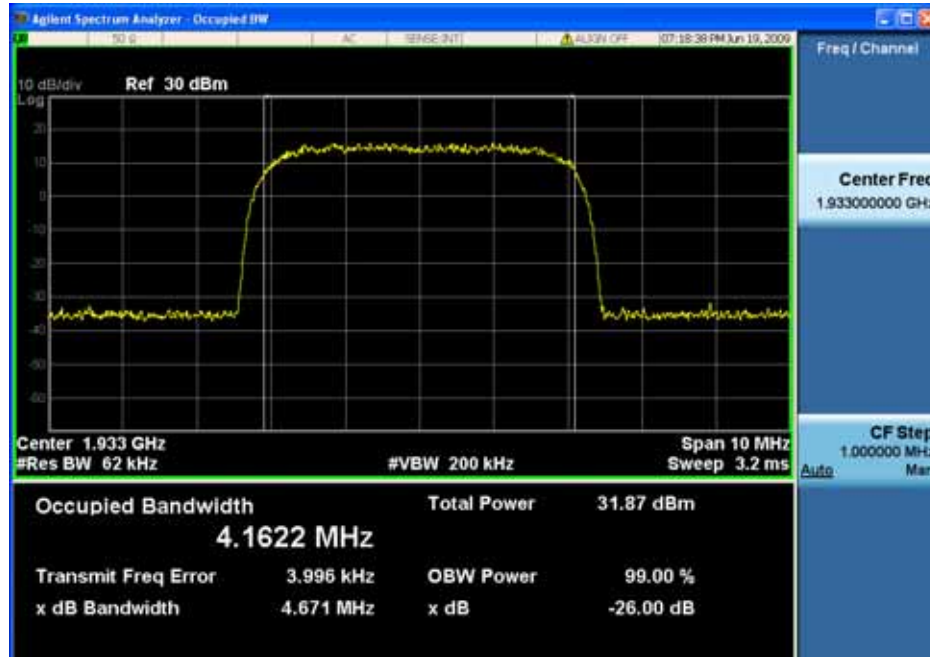

PCS—WCDMA down link(lowest frequency)--Output

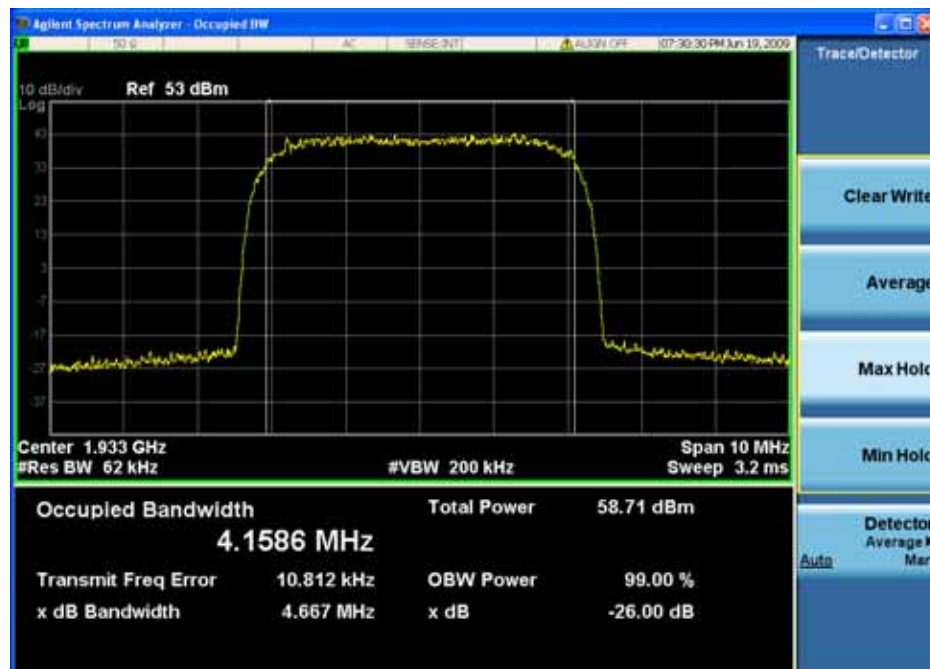



PCS—WCDMA down link(middle frequency)—Input

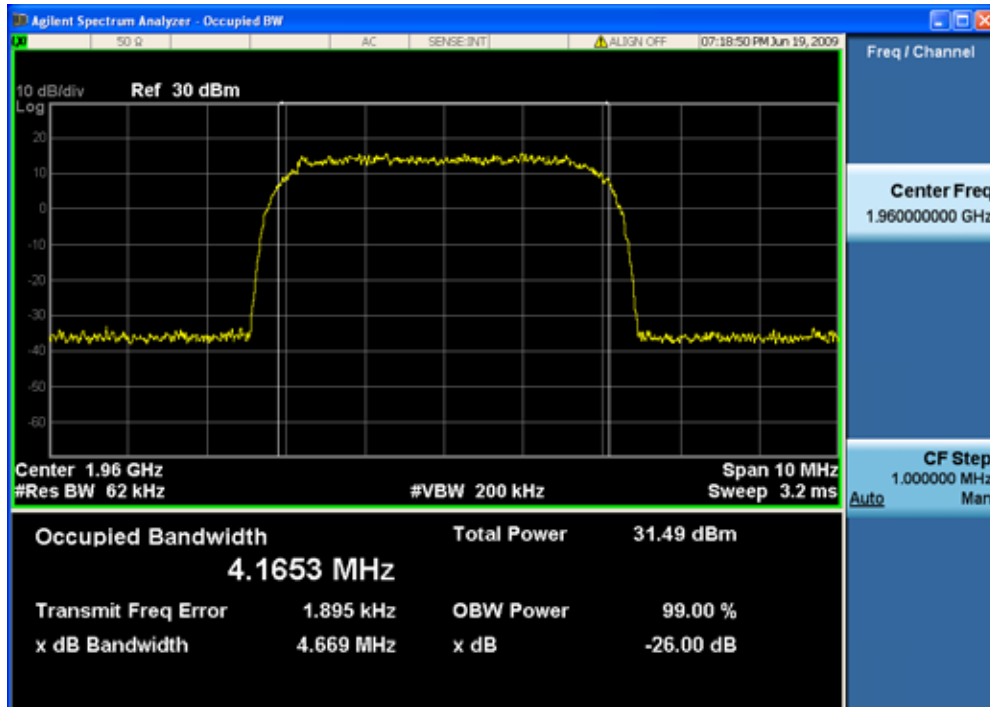

PCS—WCDMA down link(middle frequency)--Output

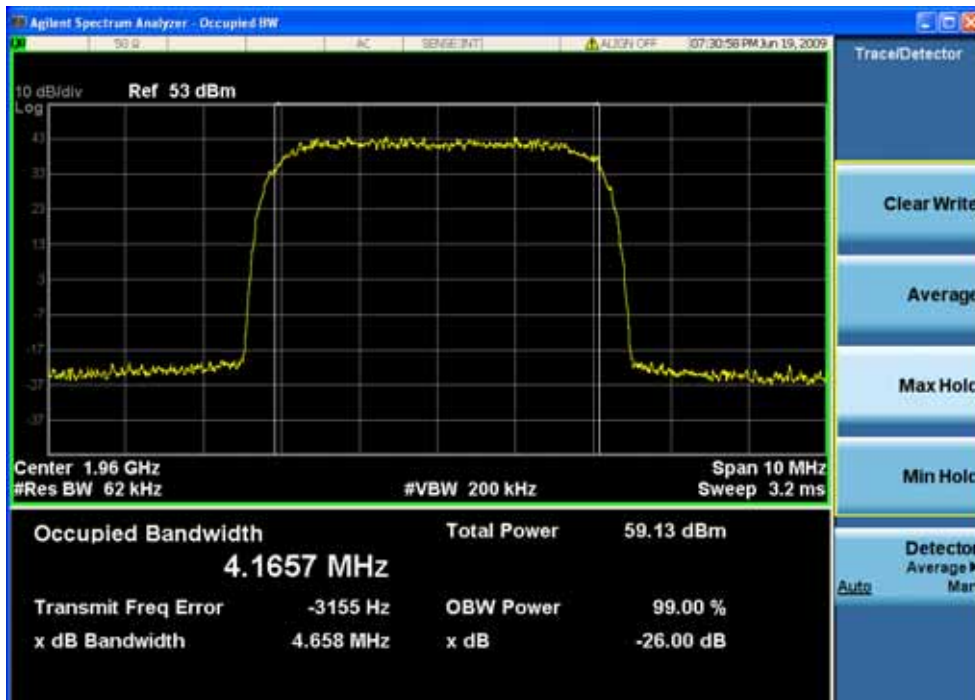



PCS—WCDMA down link(highest frequency)—Input

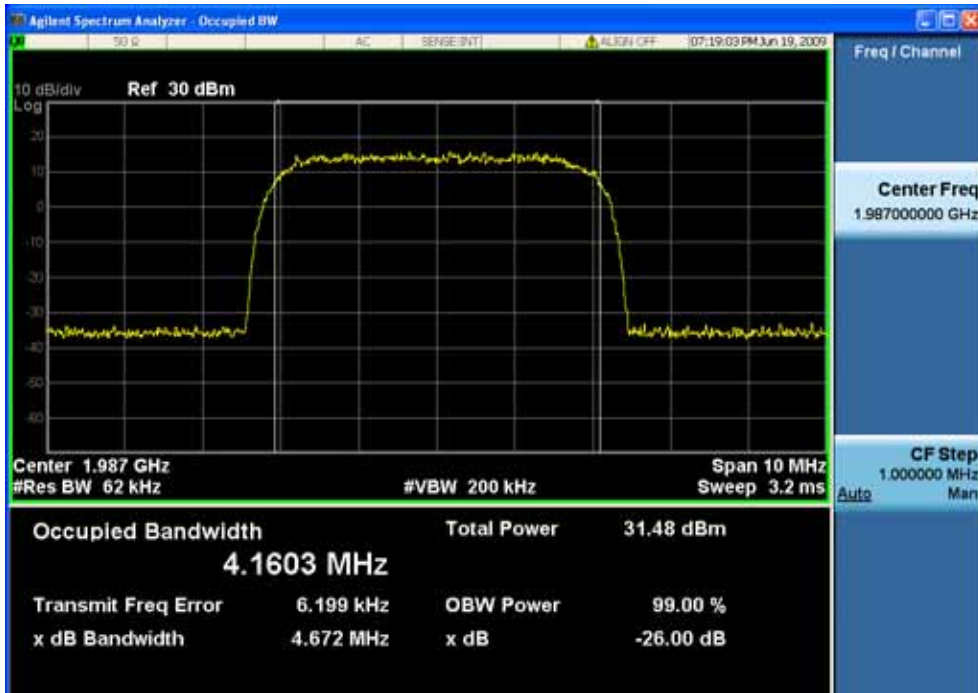

PCS—WCDMA down link(highest frequency)--Output

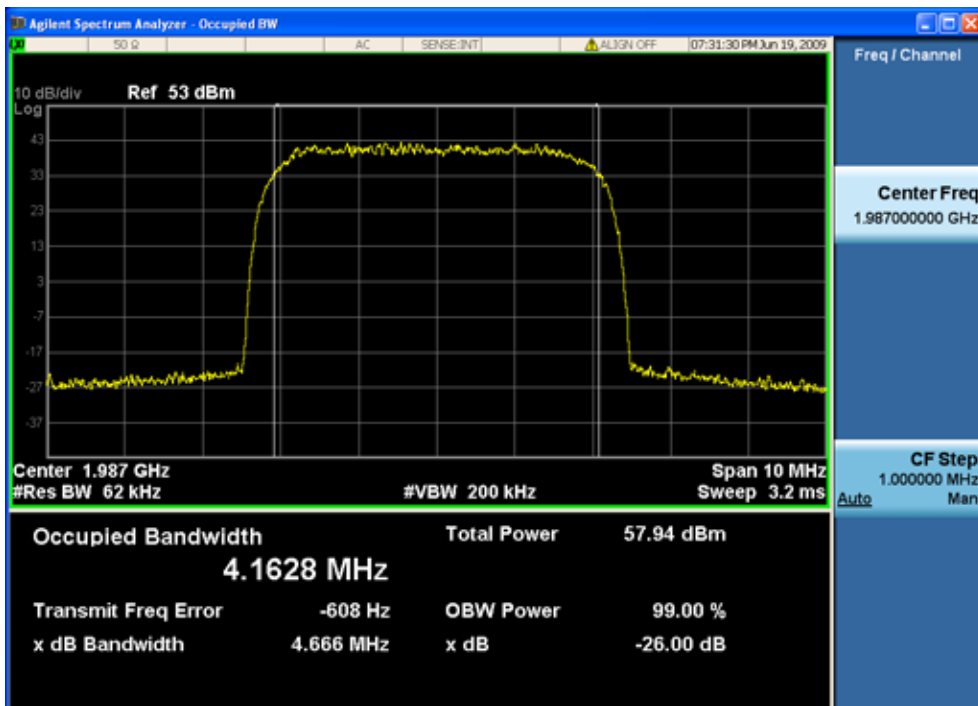



# SGS-CSTC Standards Technical Services Co., Ltd.

Report No.: GLEMO09060172201

Page: 69 of 89

FCC ID: PX8TS-19-12XXXXXX

4x2 System

PCS Band

PCS—TDMA down link(lowest frequency)—Input

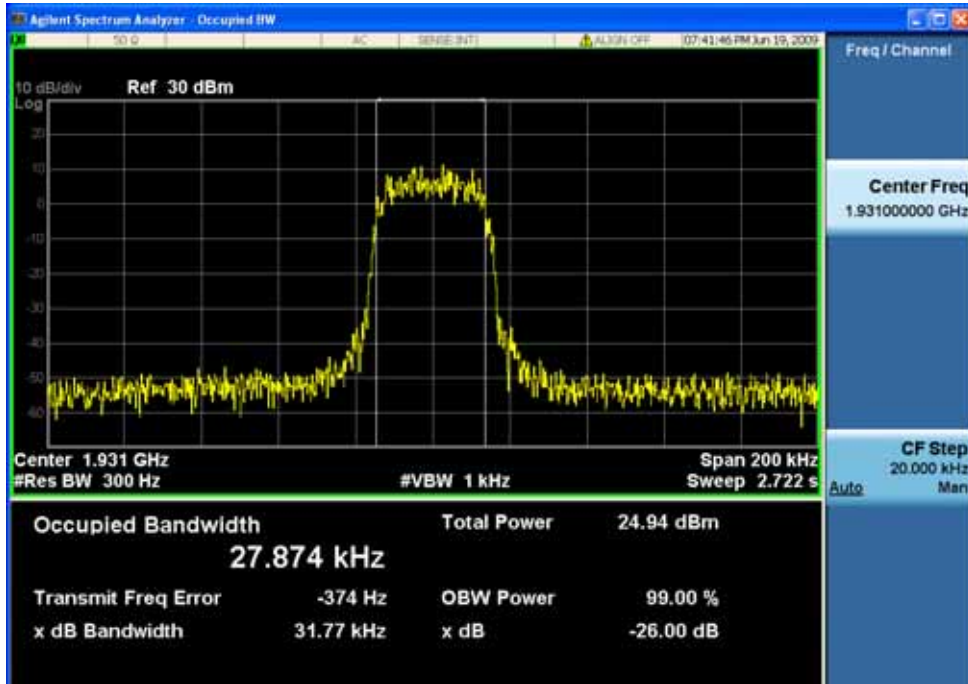

PCS—TDMA down link(lowest frequency)—Output

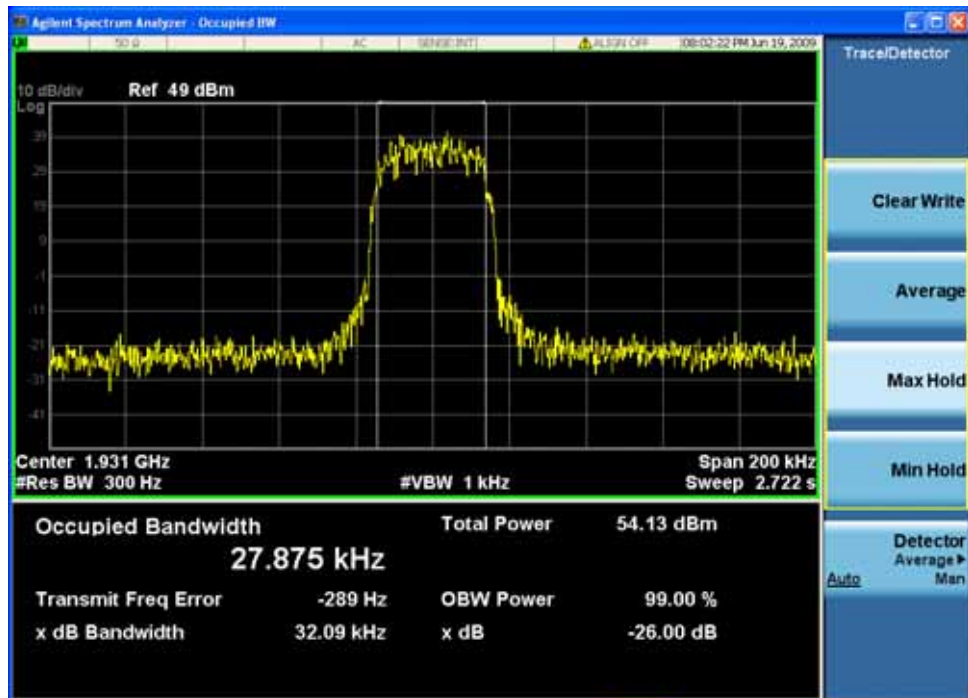



PCS—TDMA down link(middle frequency)—Input

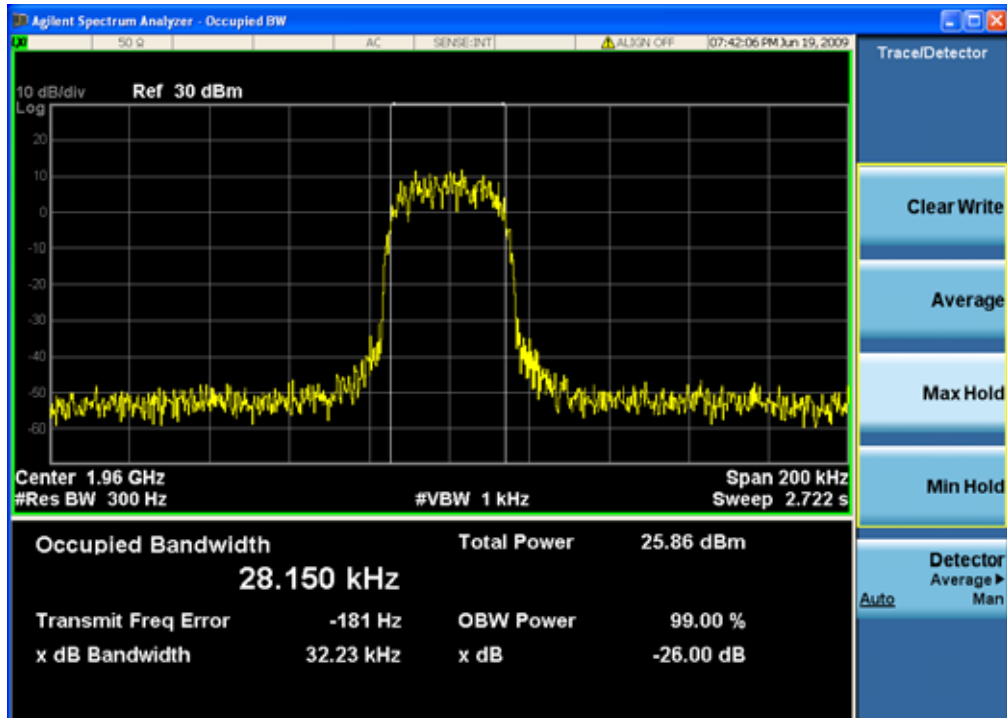

PCS—TDMA down link(middle frequency)--Output

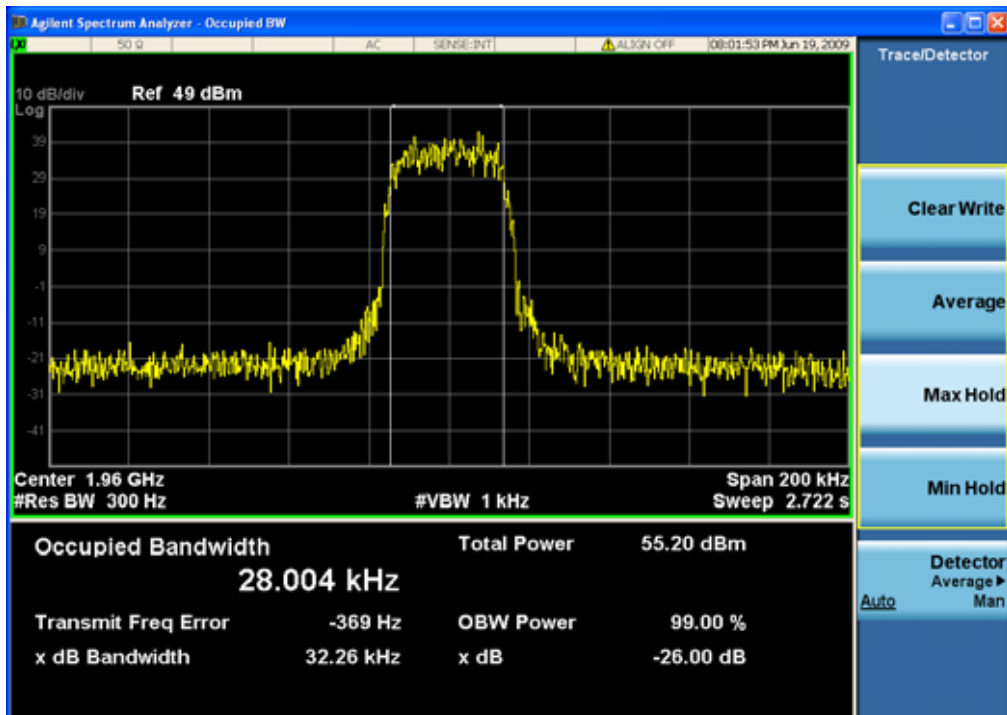



PCS—TDMA down link(highest frequency)—Input

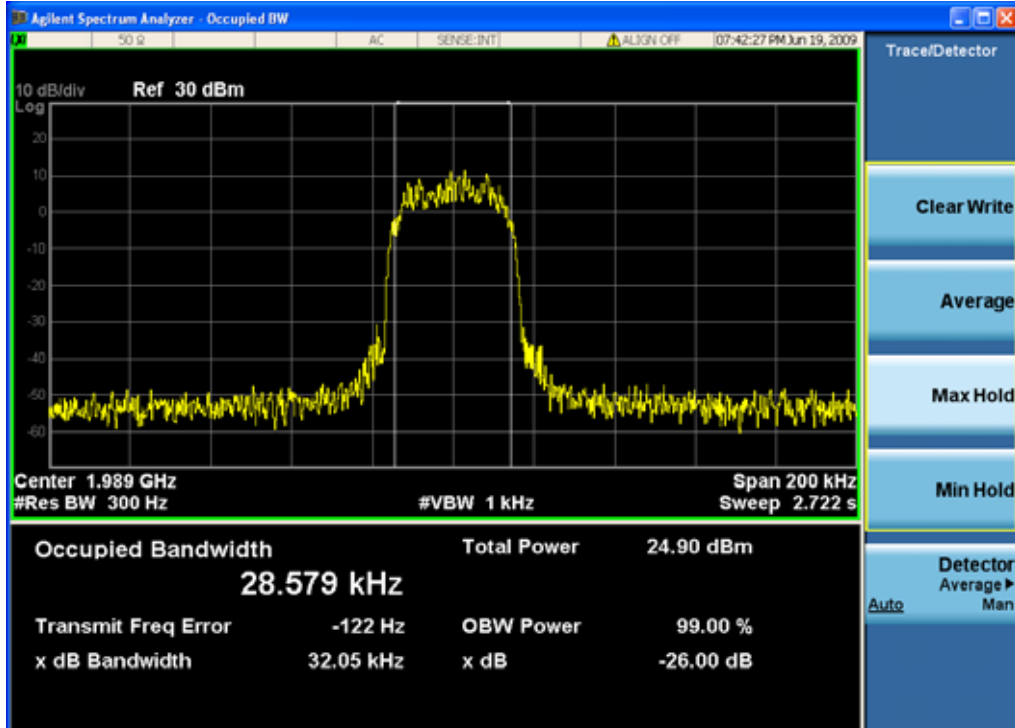

PCS—TDMA down link(highest frequency)--Output

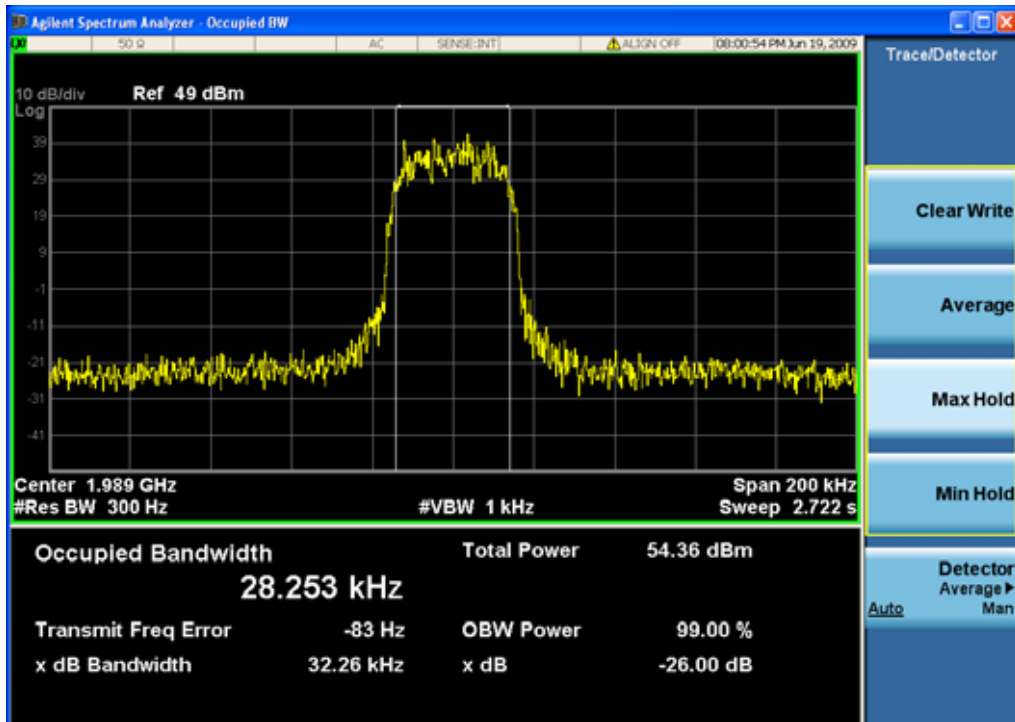

**PCS Band**

PCS—GSM down link(lowest frequency)—Input

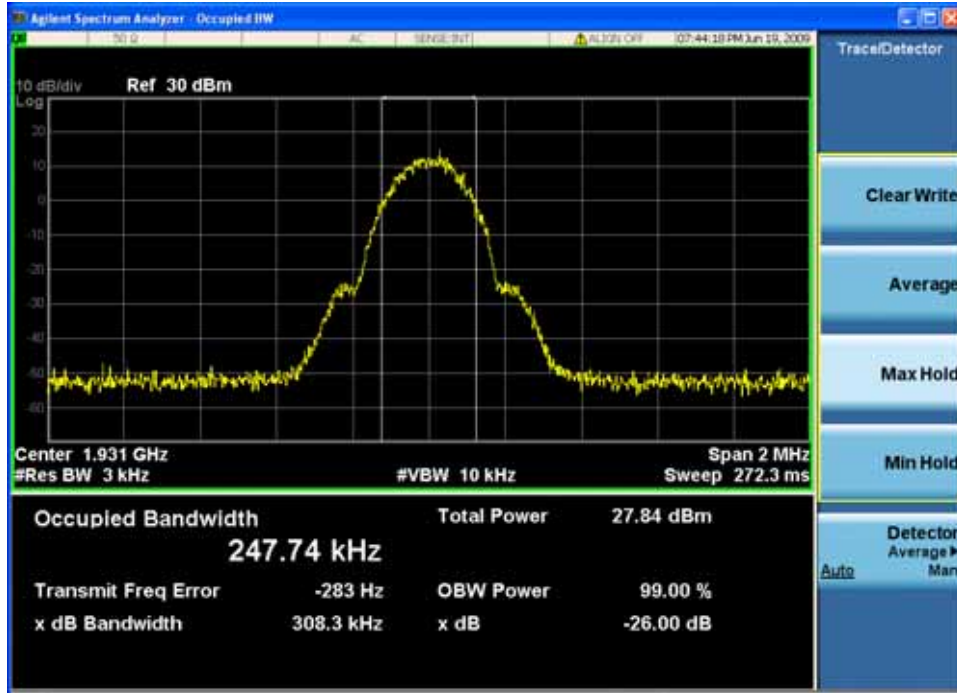

PCS—GSM down link(lowest frequency)—Output







PCS—GSM down link(middle frequency)—Input

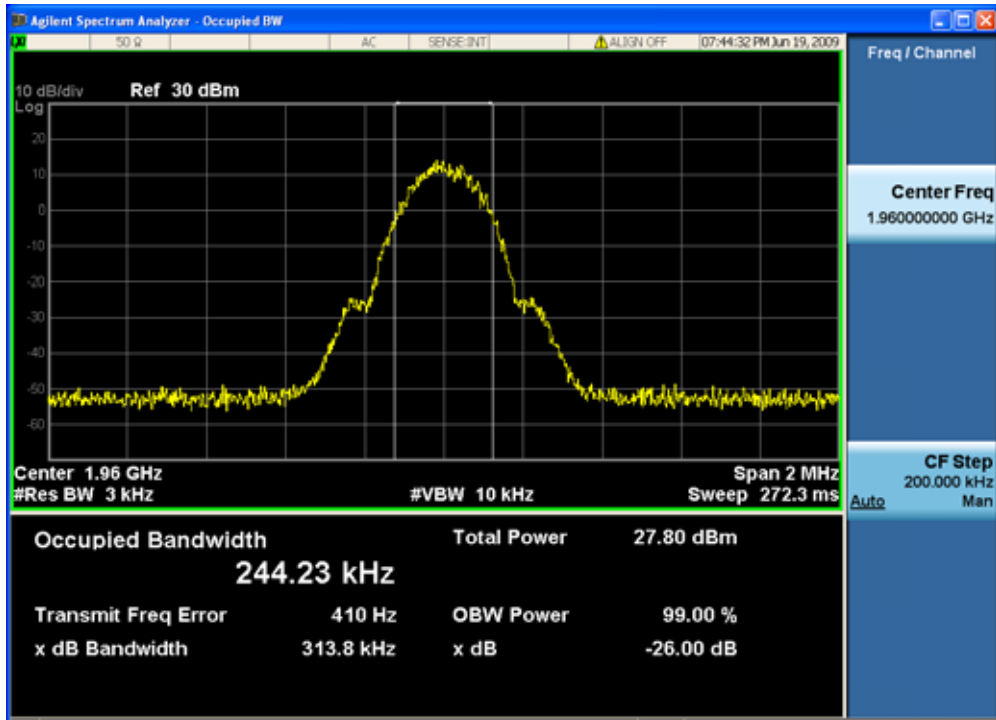

PCS—GSM down link(middle frequency)—Output

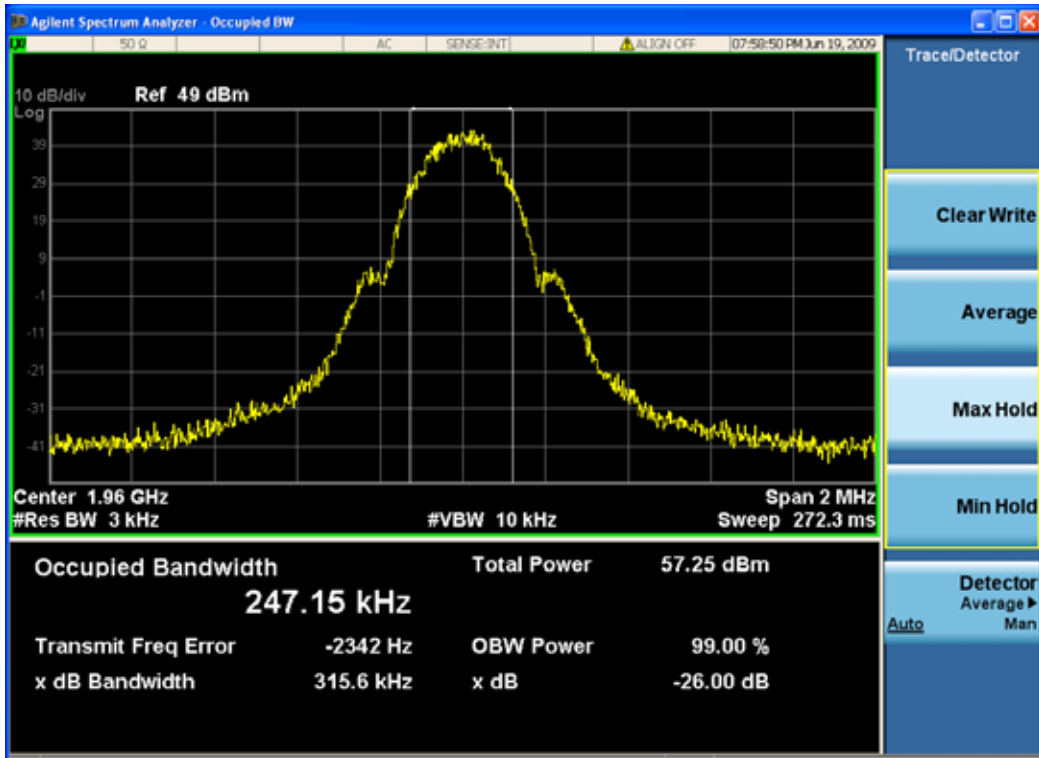



PCS—GSM down link(highest frequency)—Input

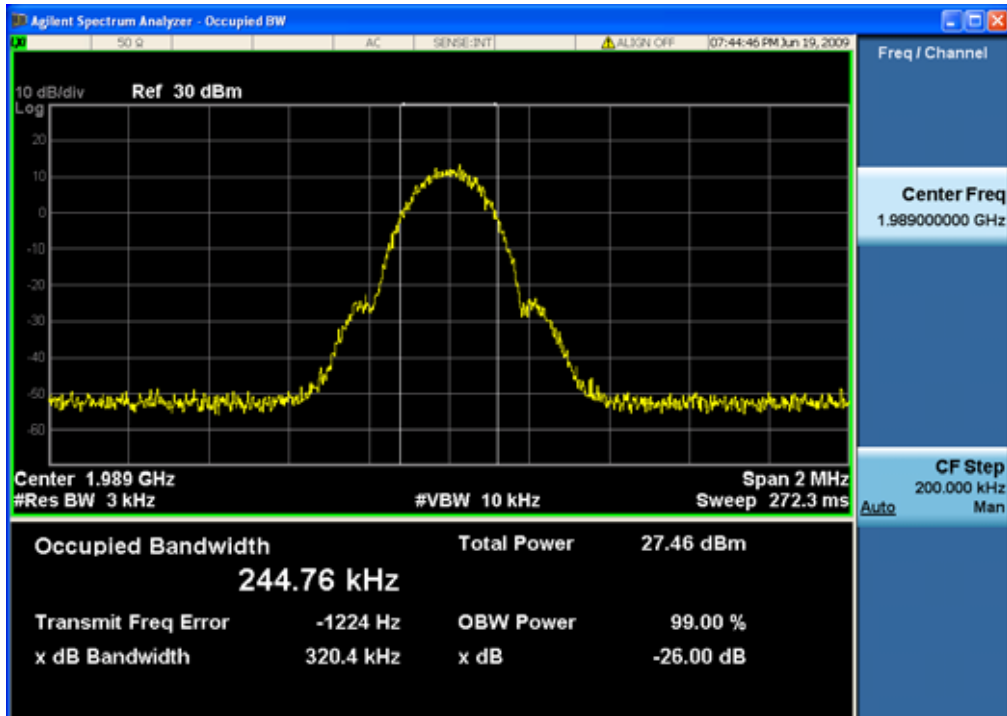

PCS—GSM down link(highest frequency)--Output

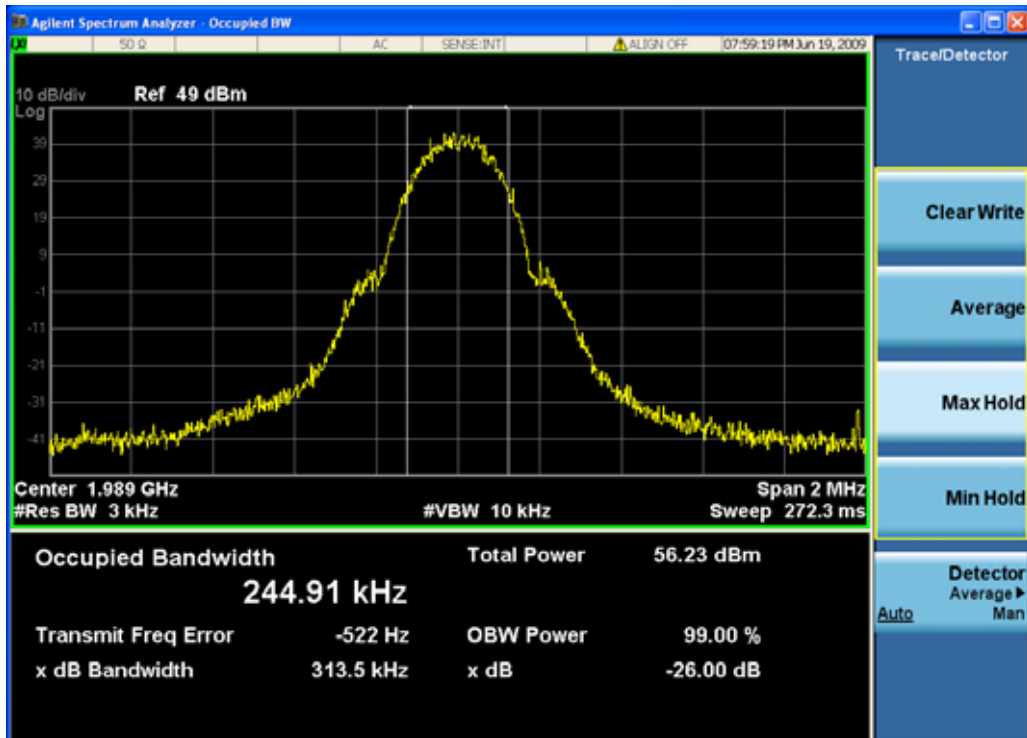



PCS Band

PCS—EDGE down link(lowest frequency)—Input

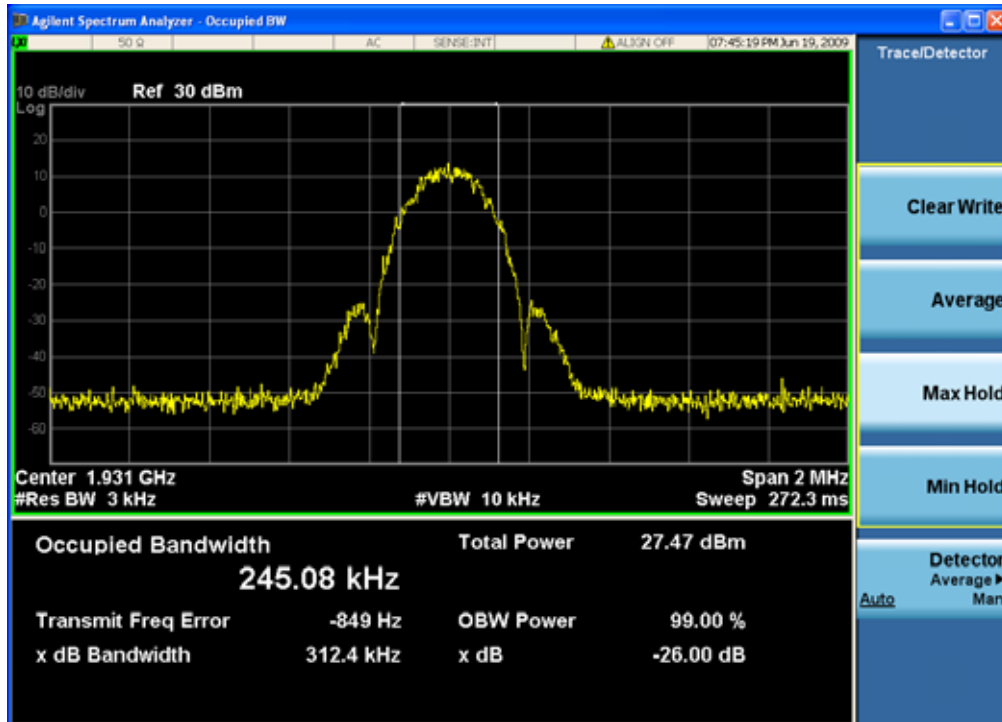

PCS—EDGE down link(lowest frequency)—Output

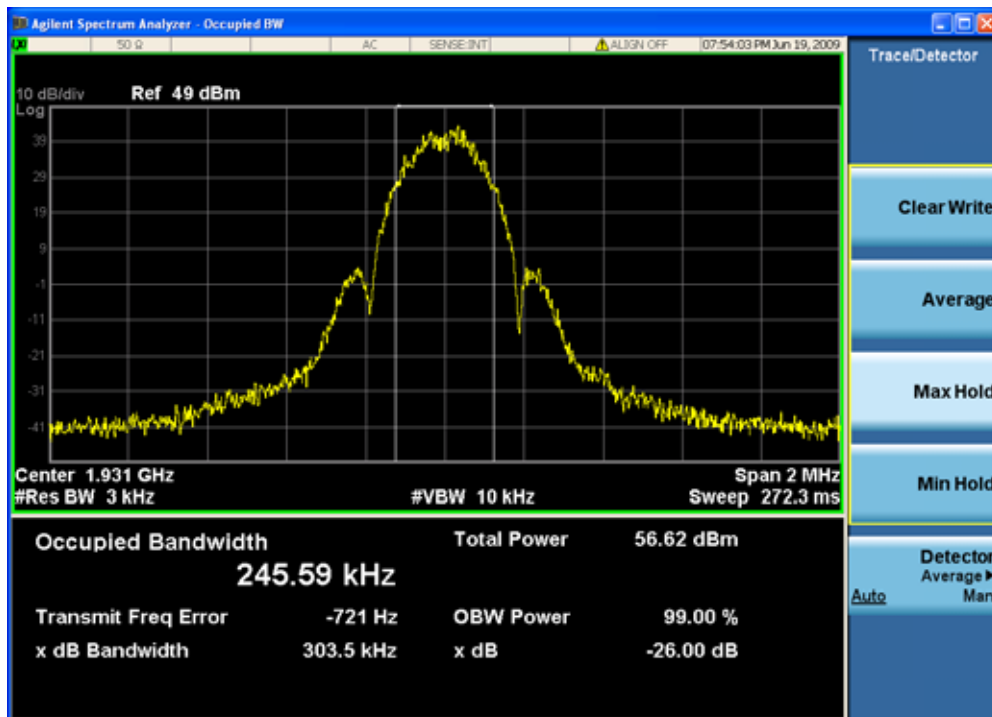

PCS—EDGE down link(middle frequency)—Input

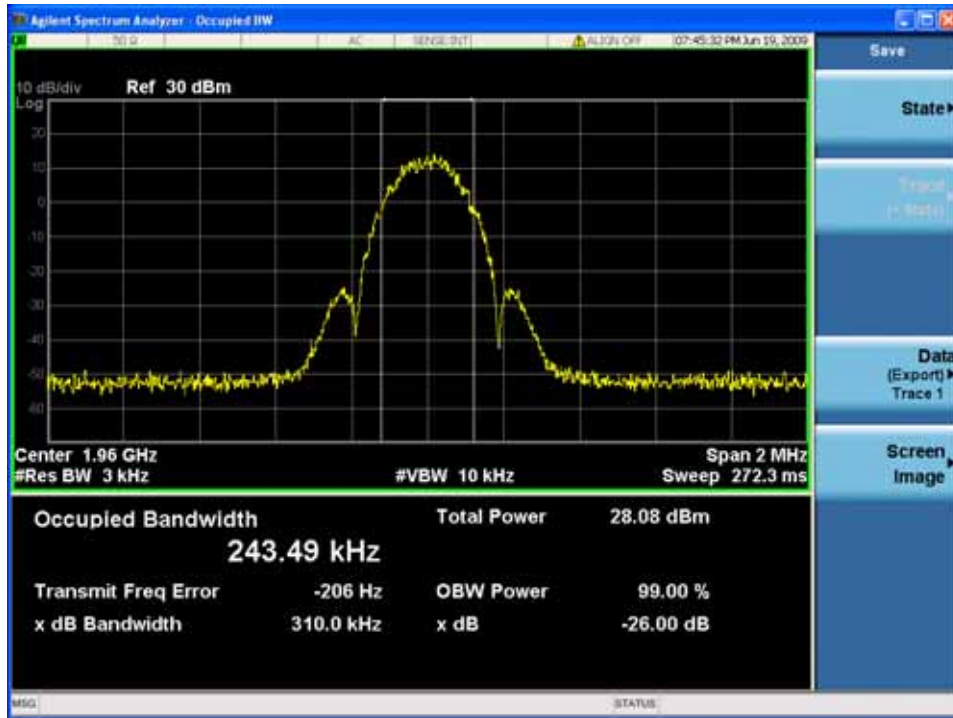

PCS—EDGE down link(middle frequency)—Output

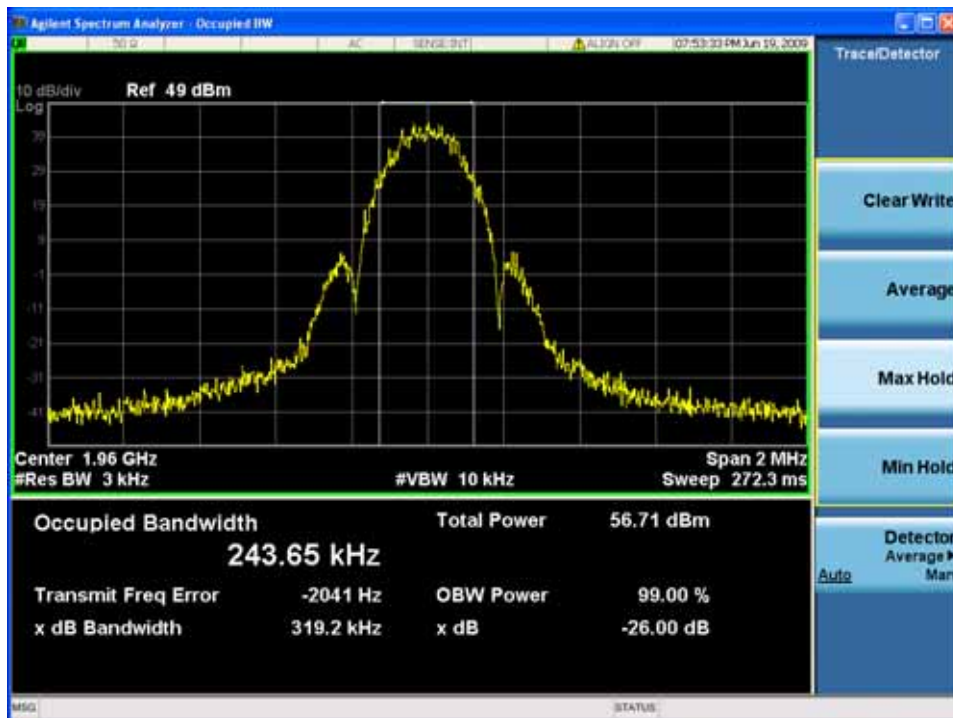



PCS—EDGE down link(highest frequency)—Input

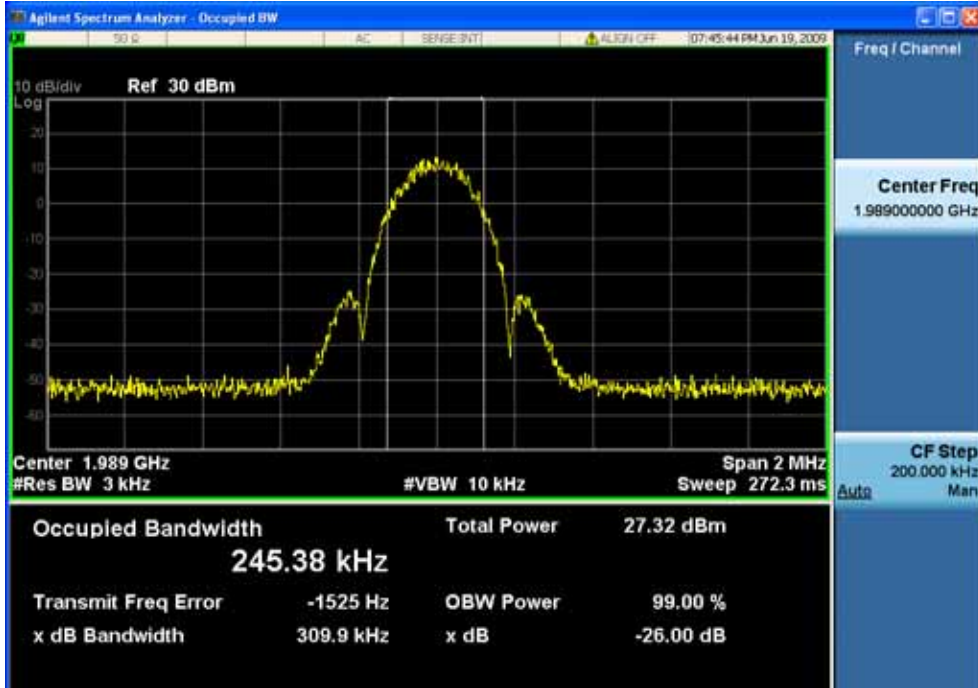

PCS—EDGE down link(highest frequency)--Output

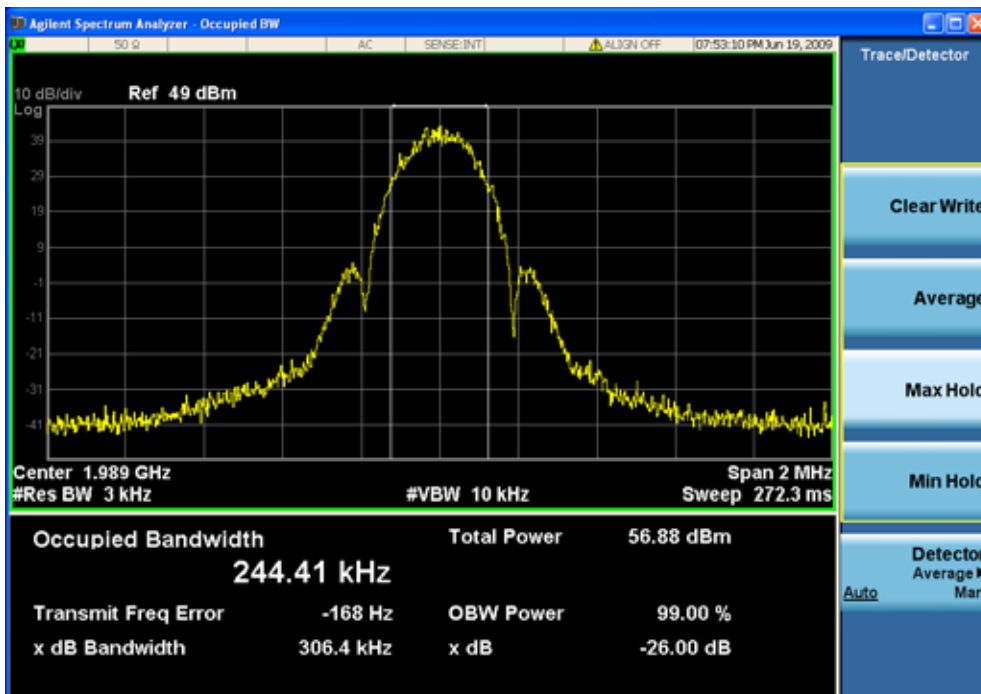

**PCS Band**

PCS—CDMA down link(lowest frequency)—Input

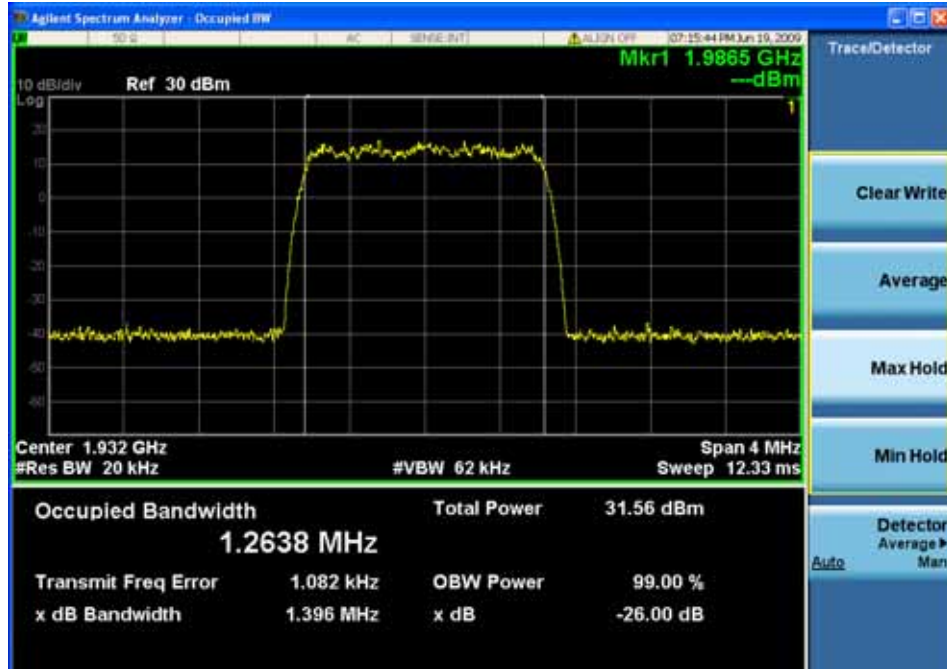

PCS—CDMA down link(lowest frequency)--Output

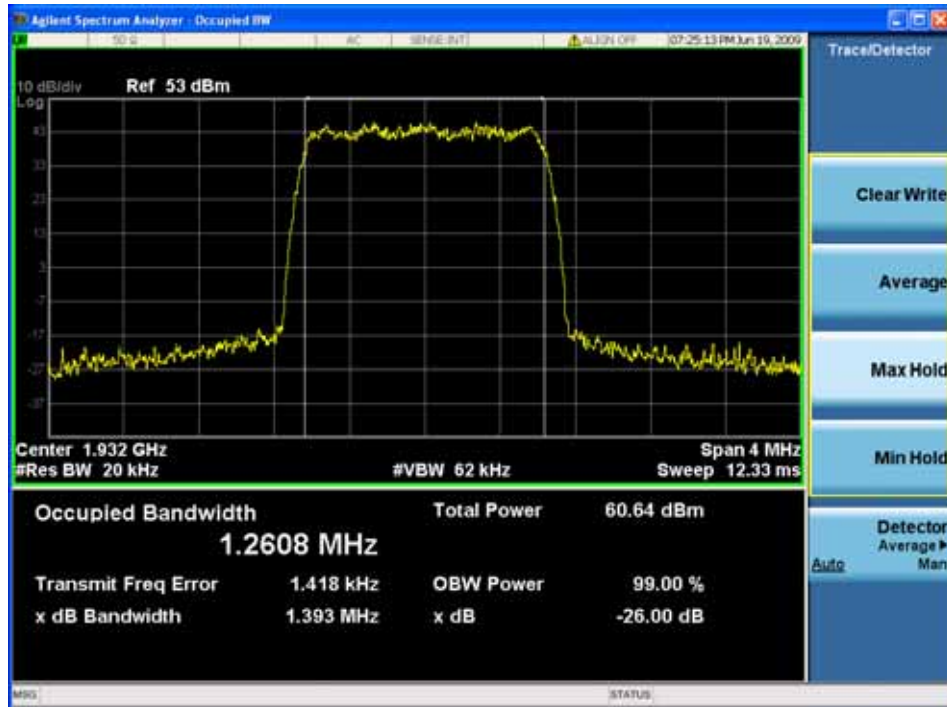



# SGS-CSTC Standards Technical Services Co., Ltd.

Report No.: GLEMO09060172201

Page: 79 of 89

FCC ID: PX8TS-19-12XXXXXX

PCS—CDMA down link(middle frequency)—Input

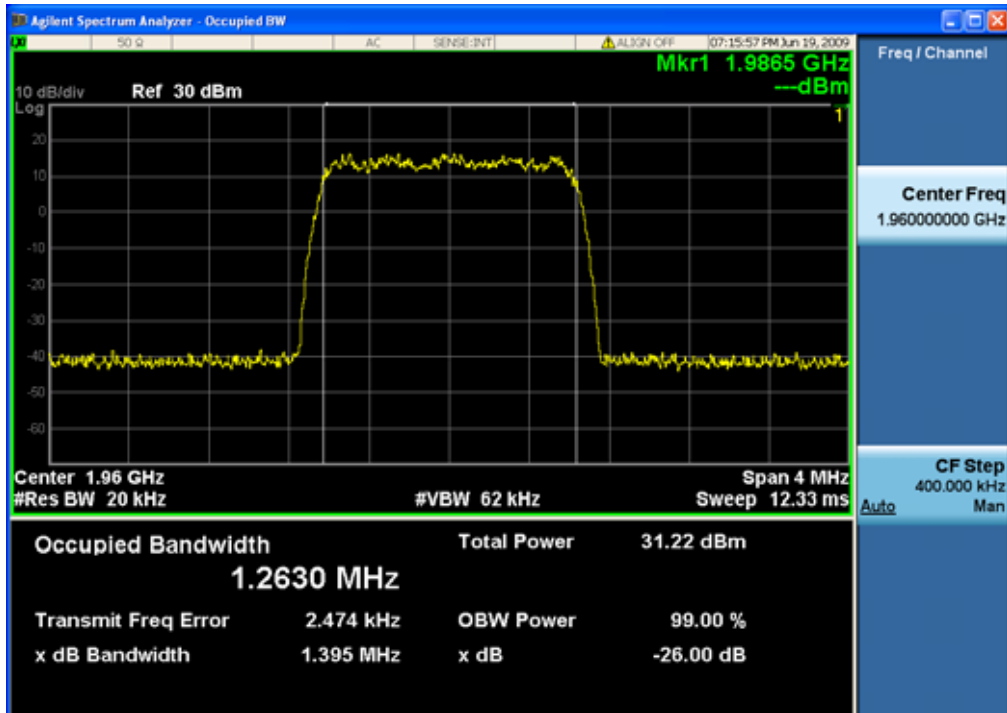

PCS—CDMA down link(middle frequency)--Output

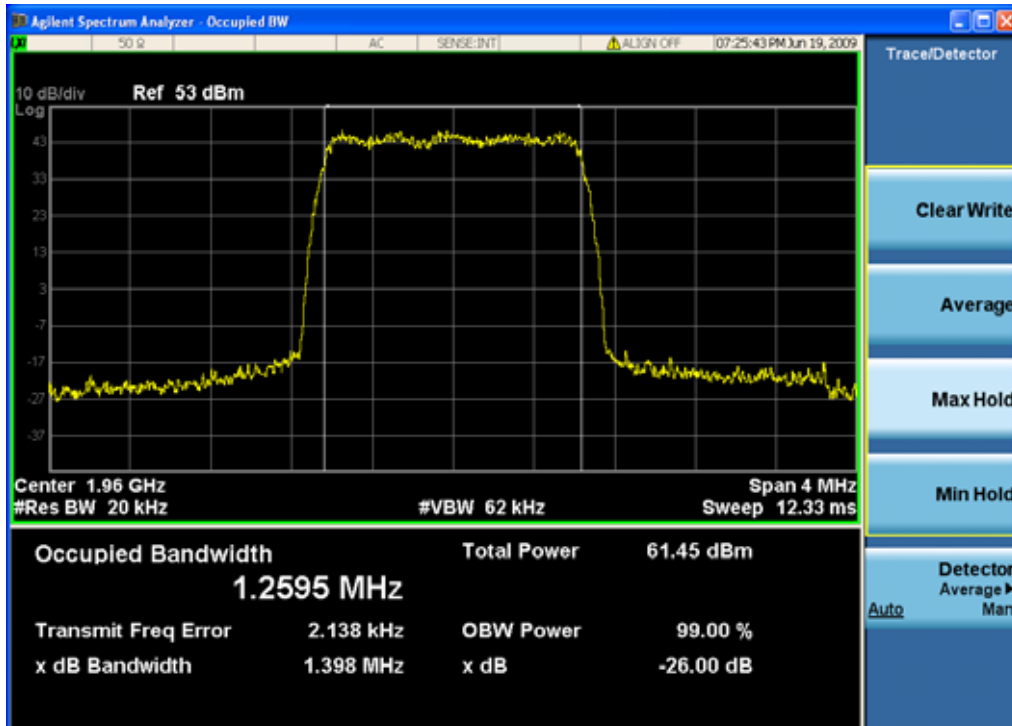



PCS—CDMA down link(highest frequency)—Input

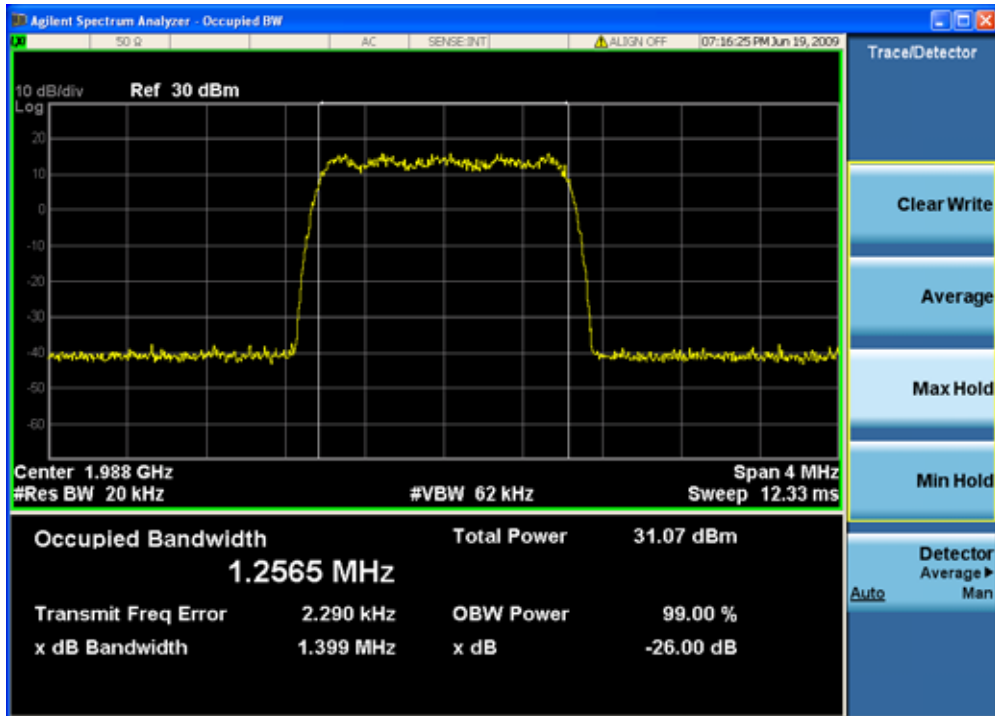

PCS—CDMA down link(highest frequency)--Output

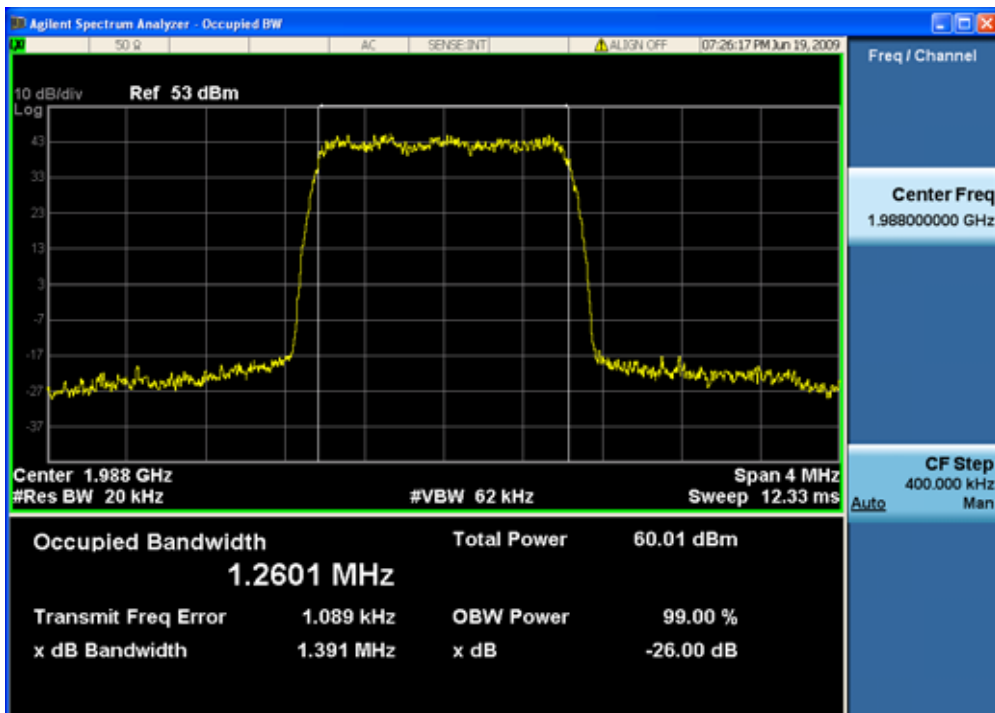





PCS Band

PCS—WCDMA down link(lowest frequency)—Input

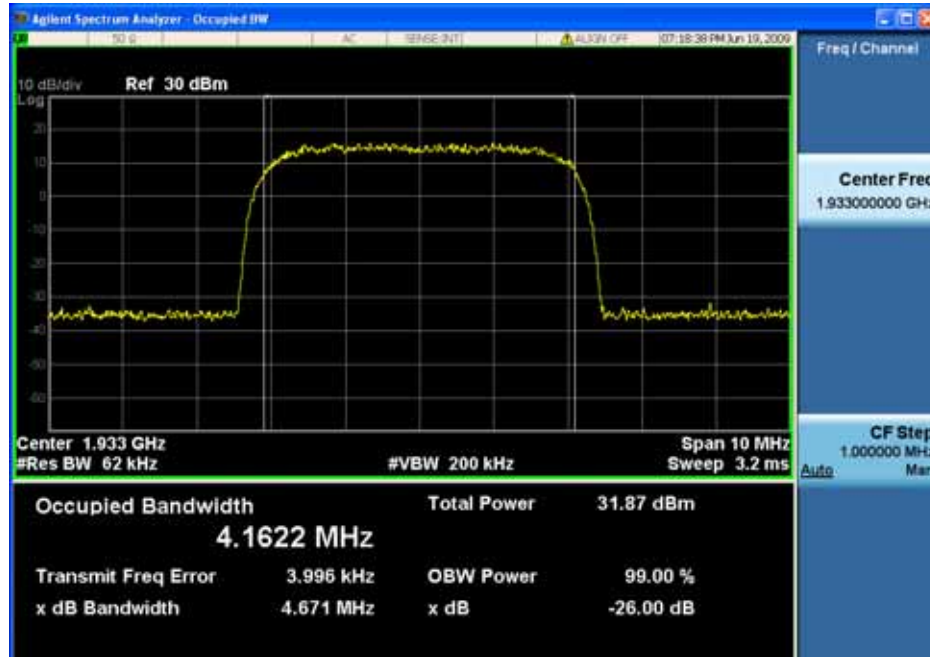

PCS—WCDMA down link(lowest frequency)--Output

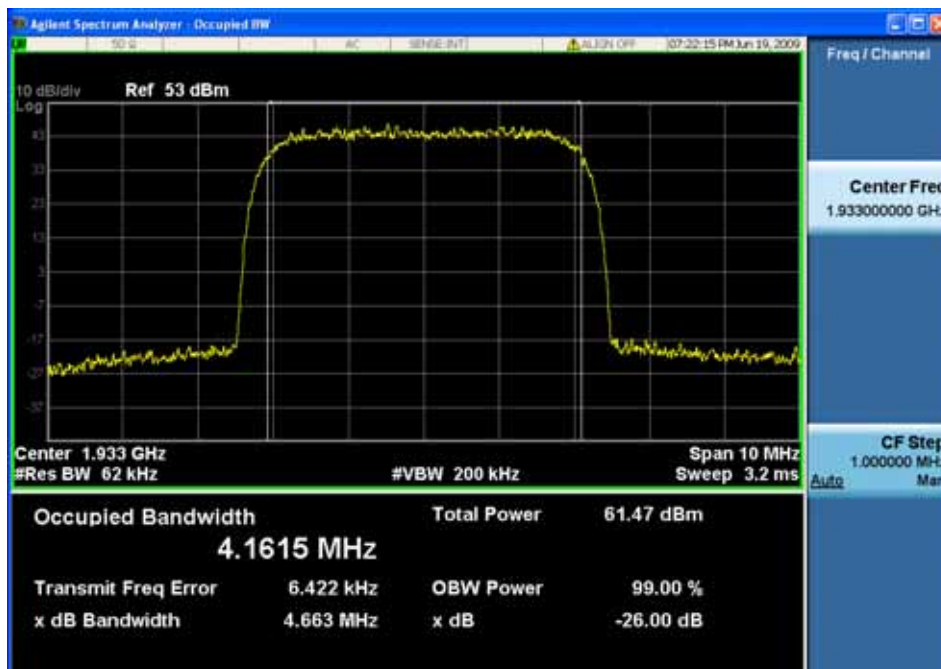



PCS—WCDMA down link(middle frequency)—Input

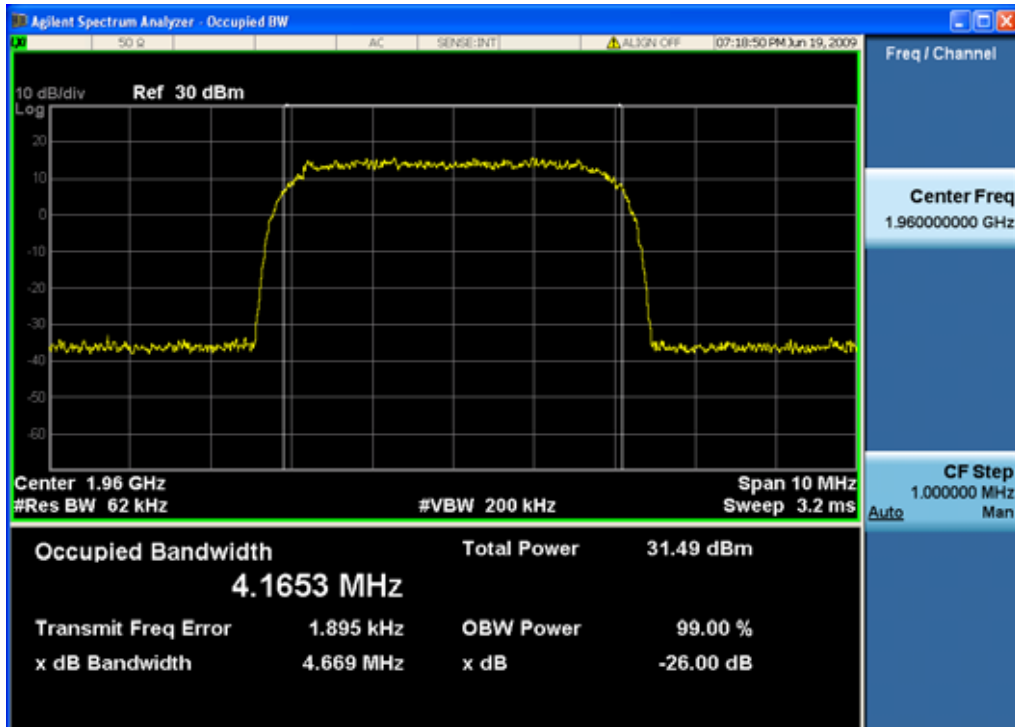

PCS—WCDMA down link(middle frequency)—Output

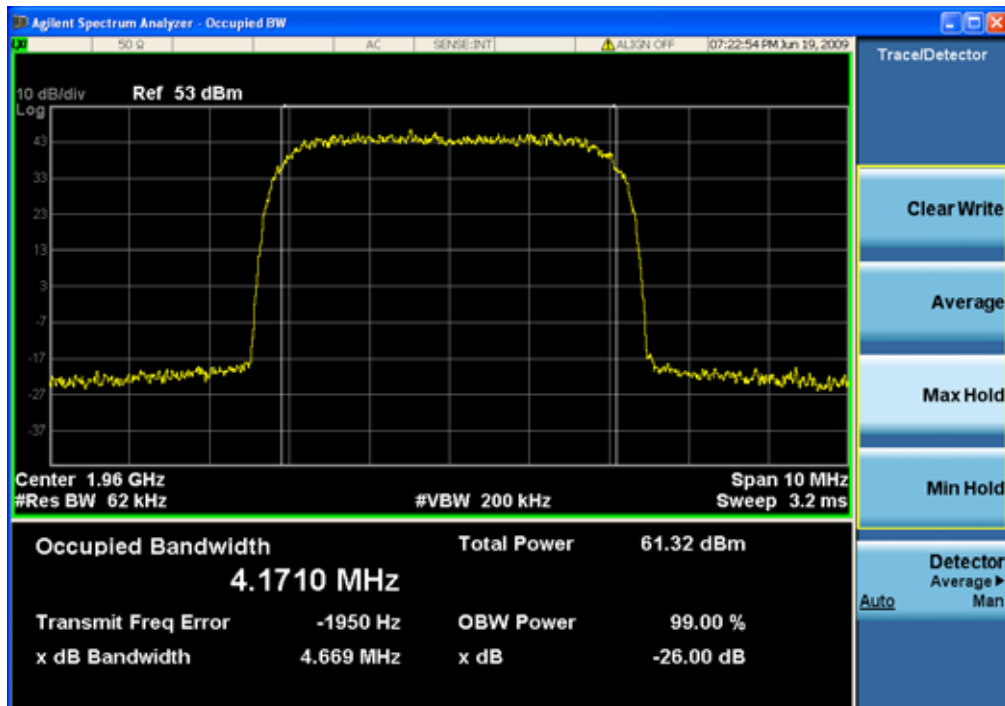

PCS—WCDMA down link(highest frequency)—Input

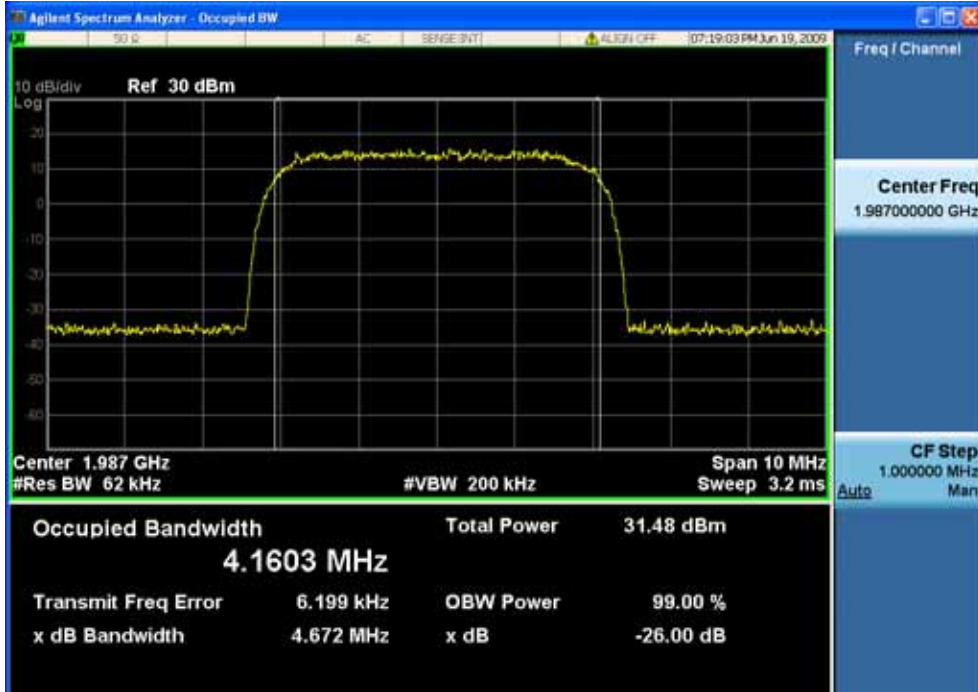

PCS—WCDMA down link(highest frequency)--Output

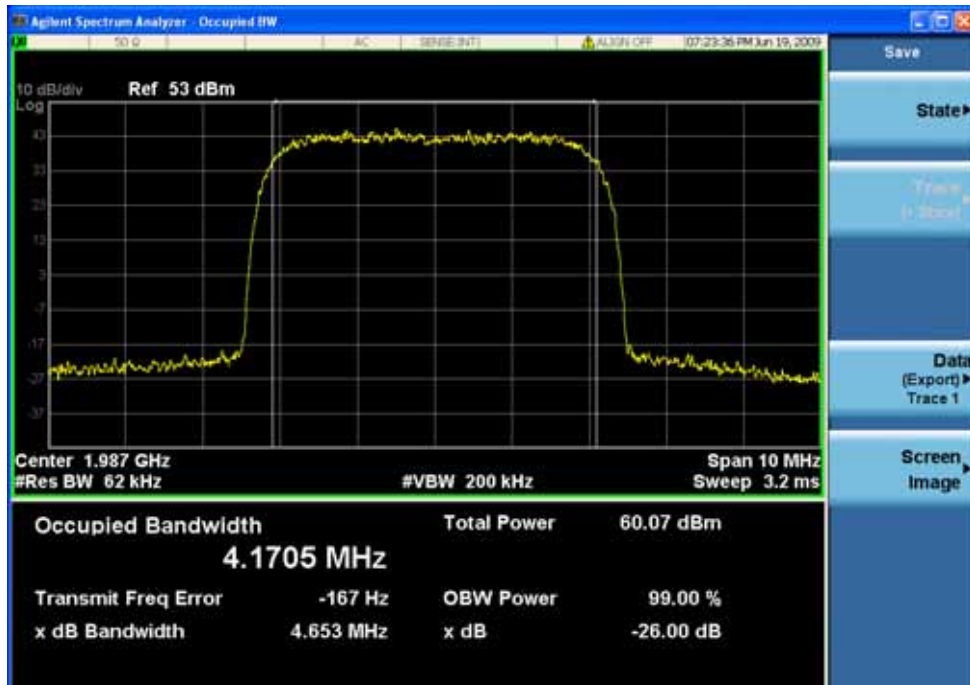

### 7.2.6 Out of Band Rejection

Test Date: 17 to 19 June 2009

Test Requirement: 2-11-04/EAB/RF

Test for rejection of out of band signals. Filter freq. response plots are acceptable.

Test Method: 2-11-04/EAB/RF

EUT Operation:

Status: The output power of EUT be set to maximum value.

Conditions: Normal conditions

Application: PCS Band RF output ports

Test Configuration:

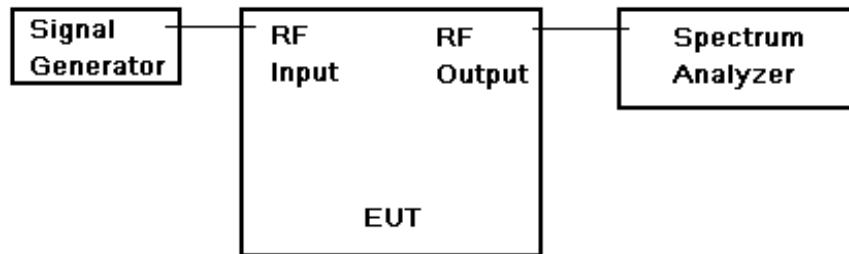

Fig.4. Out of Band rejection test configuration

Test Procedure:

1. Connect the equipment as illustrated;
  2. Test the background noise level with all the test facilities;
  3. Keep one transmitting path, all other connectors shall be connected by normal power or RF leads;
  4. Select the attenuator to avoid the test receiver or spectrum analyzer being destroyed;
  5. Keep the EUT continuously transmitting in max power;
  6. Signal generator sweep from the frequency more lower than the product frequency to the frequency more higher than it, find the product band filter characteristic;
- CW signal rather than typical signal is acceptable (for FM).
  - Multiple band filter will need test each other.



7.2.6.1 Measurement Record:

PCS Band

PCS—down link

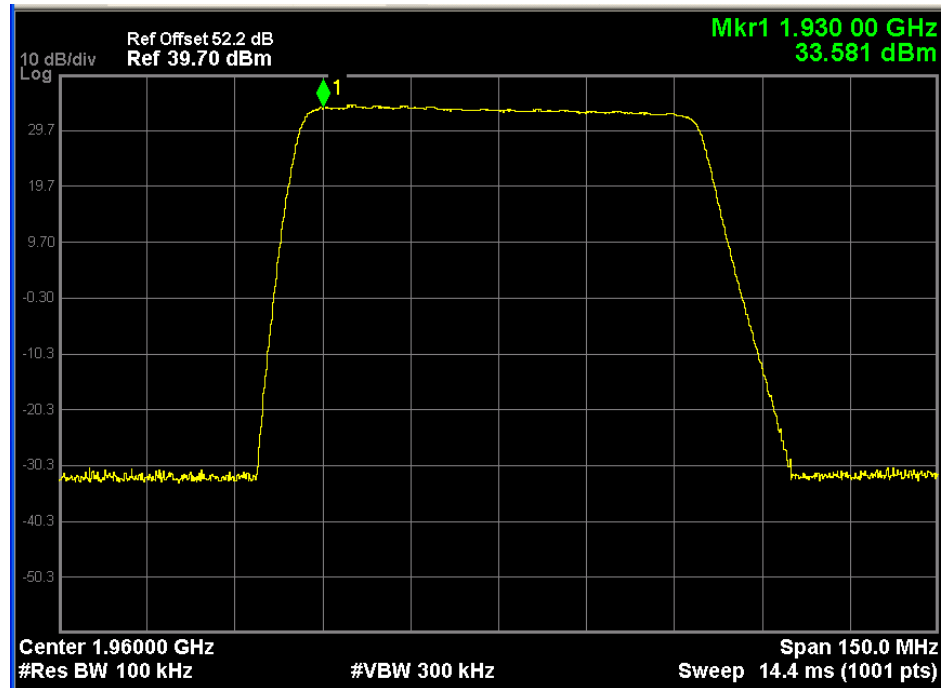



### 7.2.7 Frequency Stability

Test Date: 17 to 19 June 2009

Test Requirement: FCC part 24.235

Test Method: FCC part 2.1055

EUT Operation:

Status: The output power of EUT be set to maximum value.

Conditions: Temperature conditions, voltage conditions

Application: Cellular Band RF output ports, PCS Band RF output ports

Test Procedure:

1. Temperature conditions:
  - a) record the 20°C and nominal voltage frequency value as reference point;
  - b) vary the temperature from -30°C to 60°C with step 10°C
  - c) when reach a temperature point, keep the temperature balance at least 1 hour to make the product working in this status;
  - d) read the frequency at the relative temperature.
2. Voltage conditions:
  - a) record the 20°C and nominal voltage frequency value as reference point;
  - b) vary the voltage from -15% nominal voltage to +15% voltage;
  - c) read the frequency at the relative voltage.

#### 7.2.7.1 Measurement Record:

1. Frequency Stability vs temperature: Pass
2. Frequency Stability vs voltage: Pass

#### Test Conclusion:

The EUT belongs to AMP class, the EUT have no frequency translate and is transparent for the frequency transmitting, there were no offset observed in temperature and voltage conditions change.

### 7.2.8 Radiated Emissions, 30MHz to 10GHz

|                       |  |
|-----------------------|--|
| Test Requirement:     | FCC Part15 B   |
| Test Method:          | ANSI C63.4   |
| Frequency Range:      | 30MHz to10GHz( base FCC part 15.33)  |
| Measurement Distance: | 10m  |
| Class:                | Class A  |
| Limit:                | 39.1 dB $\mu$ V/m between 30MHz & 88MHz<br>43.5 dB $\mu$ V/m between 88MHz & 216MHz<br>46.4 dB $\mu$ V/m between 216MHz & 960MHz<br>49.5 dB $\mu$ V/m above 960MHz |

#### 7.2.8.1 E.U.T. Operation

Operating Environment:

Temperature: 25.0 °C      Humidity: 50 % RH      Atmospheric Pressure: 1005 mbar

Application: EUT enclosure

EUT Operation: Test in EUT normally working mode.

#### 7.2.8.2 Test Setup

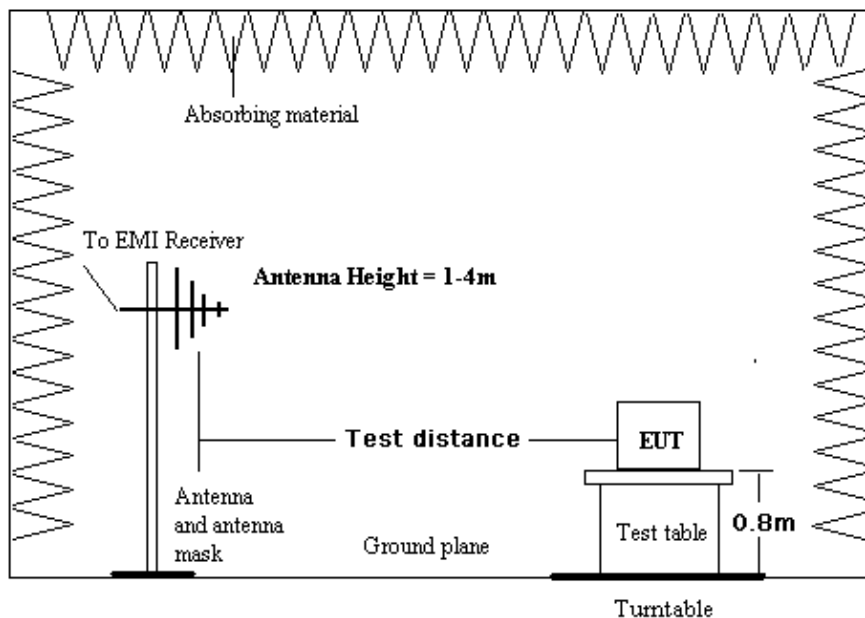



7.2.8.3 Measurement Data

An initial pre-scan was performed in the 10m chamber using the spectrum analyser in peak detection mode. Quasi-peak measurements were conducted based on the peak sweep graph. The EUT was measured by Bilog antenna with 2 orthogonal polarities

The following quasi-peak measurements were performed on EUT:

Vertical:

Peak scan

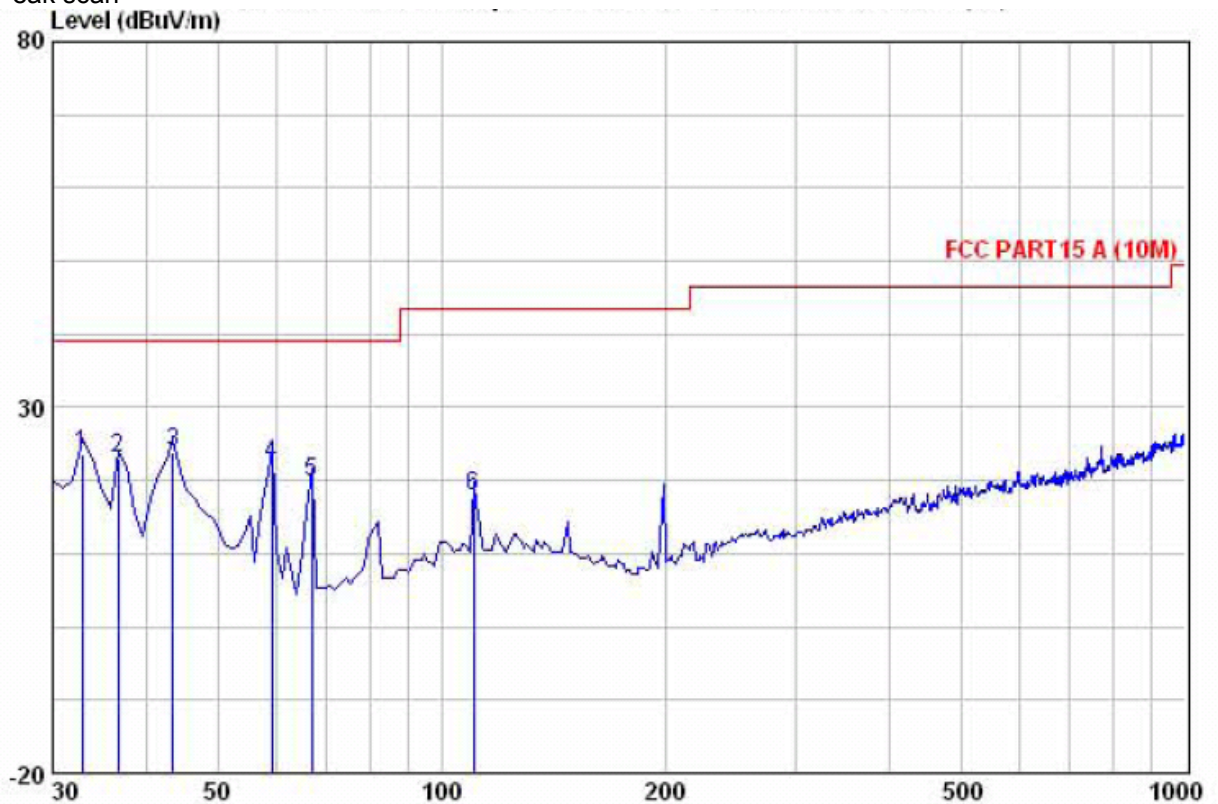

Quasi-peak measurement:

|     | Freq    | Read  | Antenna | Cable | Preamp | Limit  | Over   |           |
|-----|---------|-------|---------|-------|--------|--------|--------|-----------|
|     | MHz     | Level | Factor  | Loss  | Factor | Line   | Limit  | Remark    |
|     |         | dBuV  | dB/m    | dB    | dB     | dBuV/m | dBuV/m | dB        |
| 1 ! | 32.910  | 37.82 | 16.69   | 0.40  | 31.20  | 23.71  | 39.00  | -15.29 QP |
| 2 ! | 36.790  | 39.43 | 14.39   | 0.50  | 31.20  | 23.13  | 39.00  | -15.87 QP |
| 3 ! | 43.580  | 43.55 | 10.80   | 0.60  | 31.20  | 23.75  | 39.00  | -15.25 QP |
| 4 ! | 59.100  | 47.58 | 5.25    | 0.70  | 31.20  | 22.33  | 39.00  | -16.67 QP |
| 5 ! | 66.860  | 45.80 | 4.48    | 0.70  | 31.20  | 19.78  | 39.00  | -19.22 QP |
| 6 ! | 110.510 | 36.67 | 11.50   | 0.90  | 31.20  | 17.87  | 43.50  | -25.63 QP |





Horizontal:

Peak scan

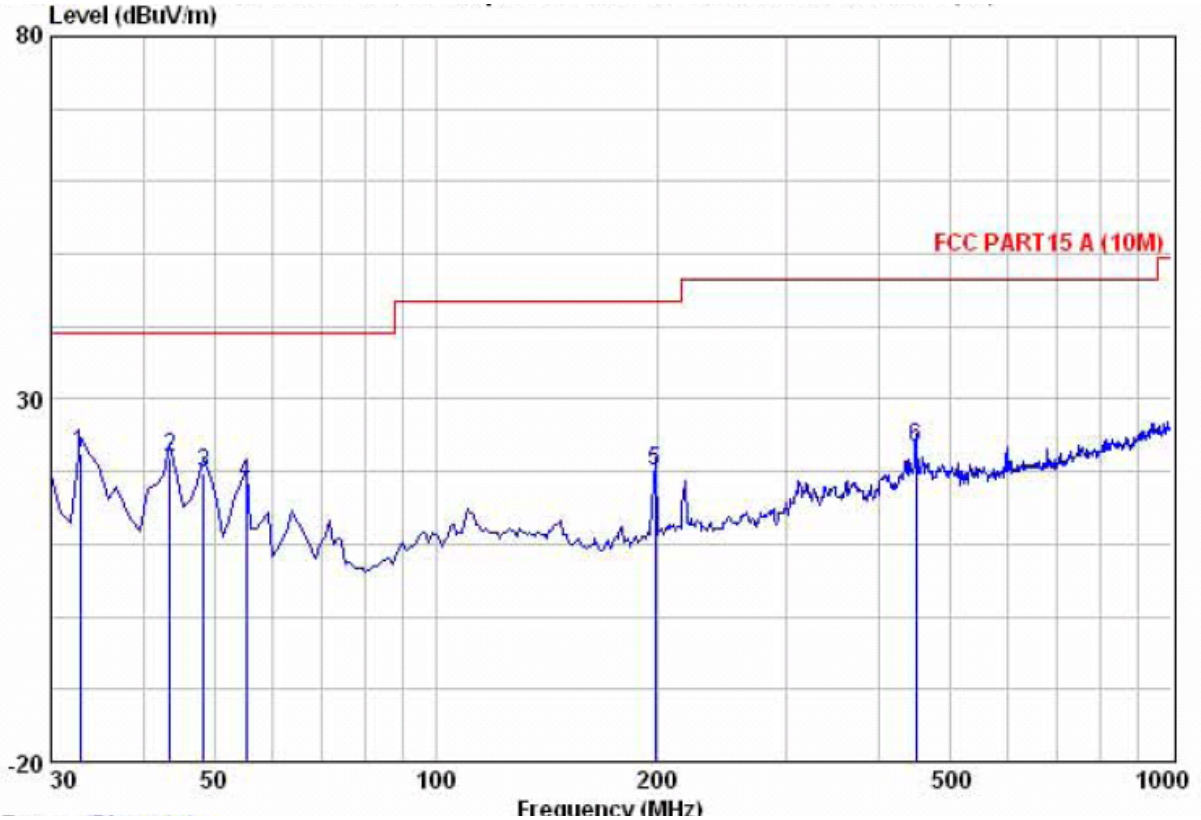

Quasi-peak measurement:

|     | Freq    | Read Level | Antenna Factor | Cable Loss | Preamp Factor | Level  | Limit Line | Over Limit | Remark |
|-----|---------|------------|----------------|------------|---------------|--------|------------|------------|--------|
|     | MHz     | dBuV       | dB/m           | dB         | dB            | dBuV/m | dBuV/m     | dB         |        |
| 1 ! | 32.910  | 36.74      | 16.69          | 0.40       | 31.20         | 22.63  | 39.00      | -16.37     | QP     |
| 2 ! | 43.580  | 41.71      | 10.80          | 0.60       | 31.20         | 21.91  | 39.00      | -17.09     | QP     |
| 3 ! | 48.430  | 41.70      | 8.64           | 0.70       | 31.20         | 19.84  | 39.00      | -19.16     | QP     |
| 4 ! | 55.220  | 42.57      | 6.37           | 0.70       | 31.20         | 18.44  | 39.00      | -20.56     | QP     |
| 5 ! | 198.780 | 41.24      | 8.73           | 1.20       | 31.10         | 20.07  | 43.50      | -23.43     | QP     |
| 6 ! | 450.010 | 36.46      | 16.00          | 2.00       | 31.20         | 23.26  | 46.50      | -23.24     | QP     |

1. Level = Read Level + Antenna Factor + Cable Loss – Preamp Factor.

2. 0° was the table front facing the antenna. Degree is calculated from 0° clockwise facing the antenna.

Remark: No any emissions can be found above 1GHz.

--End of the Report--