

1.1.1.1.4 Emission Mask E

(e) *Emission Mask E—6.25 kHz or less channel bandwidth equipment.* For transmitters designed to operate with a 6.25 kHz or less bandwidth, any emission must be attenuated below the power (P) of the highest emission contained within the authorized bandwidth as follows:

(1) On any frequency from the center of the authorized bandwidth f_0 to 3.0 kHz removed from f_0 : Zero dB.

(2) On any frequency removed from the center of the authorized bandwidth by a displacement frequency (f_d in kHz) of more than 3.0 kHz but no more than 4.6 kHz: At least $30 + 16.67(f_d - 3 \text{ kHz})$ or $55 + 10 \log (P)$ or 65 dB, whichever is the lesser attenuation.

(3) On any frequency removed from the center of the authorized bandwidth by more than 4.6 kHz: At least $55 + 10 \log (P)$ or 65 dB, whichever is the lesser attenuation.

(4) The reference level for showing compliance with the emission mask shall be established using a resolution bandwidth sufficiently wide (usually two or three times the channel bandwidth) to capture the true peak emission of the equipment under test. In order to show compliance with the emission mask up to and including 50 kHz removed from the edge of the authorized bandwidth, adjust the resolution bandwidth to 100 Hz with the measuring instrument in a peak hold mode. A sufficient number of sweeps must be measured to insure that the emission profile is developed. If video filtering is used, its bandwidth must not be less than the instrument resolution bandwidth. For emissions beyond 50 kHz from the edge of the authorized bandwidth, see paragraph (o) of this section. If it can be shown that use of the above instrumentation settings do not accurately represent the true interference potential of the equipment under test, an alternate procedure may be used provided prior Commission approval is obtained.

----- The following blanks -----

10.5.1.2. Occupied bandwidth

1.1.1.1.5 FCC PART 2.1049(c)

§2.1049 Measurements required: Occupied bandwidth.

The occupied bandwidth, that is the frequency bandwidth such that, below its lower and above its upper frequency limits, the mean powers radiated are each equal to 0.5 percent of the total mean power radiated by a given emission shall be measured under the following conditions as applicable:

(a) Radiotelegraph transmitters for manual operation when keyed at 16 dots per second.

(b) Other keyed transmitters—when keyed at the maximum machine speed.

(c) Radiotelephone transmitters equipped with a device to limit modulation or peak envelope power shall be modulated as follows. For single sideband and independent sideband transmitters, the input level of the modulating signal shall be 10 dB greater than that necessary to produce rated peak envelope power.

(1) Other than single sideband or independent sideband transmitters—when modulated by a 2500 Hz tone at an input level 16 dB greater than that necessary to produce 50 percent modulation. The input level shall be established at the frequency of maximum response of the audio modulating circuit.

(2) Single sideband transmitters in A3A or A3J emission modes—when modulated by two tones at frequencies of 400 Hz and 1800 Hz (for 3.0 kHz authorized bandwidth), or 500 Hz and 2100 Hz (for 3.5 kHz authorized bandwidth), or 500 Hz and 2400 Hz (for 4.0 kHz authorized bandwidth), applied simultaneously. The input levels of the tones shall be so adjusted that the two principal frequency components of the radio frequency signal produced are equal in magnitude.

1.1.1.1.6 FCC PART 90.219 (e)(4)(ii)

(4) A signal booster must be designed such that all signals that it retransmits meet the following requirements:

(i) The signals are retransmitted on the same channels as received. Minor departures from the exact provider or reference frequencies of the input signals are allowed, *provided that* the retransmitted signals meet the requirements of §90.213.

<https://www.ecfr.gov/cgi-bin/text-idx?SID=2097cbedce8abb94d012e95530a44e05&mc=true&node=pt47.5.90&rqn=div5>

02016/15

Electronic Code of Federal Regulations (eCFR)

(ii) There is no change in the occupied bandwidth of the retransmitted signals.

(iii) The retransmitted signals continue to meet the unwanted emissions limits of §90.210 applicable to the corresponding received signals (assuming that these received signals meet the applicable unwanted emissions limits by a reasonable margin).

According to FCC PART 2.1049(c), FCC PART 90.219 (e)(4)(ii) and (iii) requirement, the occupied bandwidth, that is the frequency bandwidth such that below its lower and above its upper frequency limits, the mean powers radiated are each equal to 0.5 percent of the total mean power radiated by a given emission shall be measured.

10.5.2. Test configuration

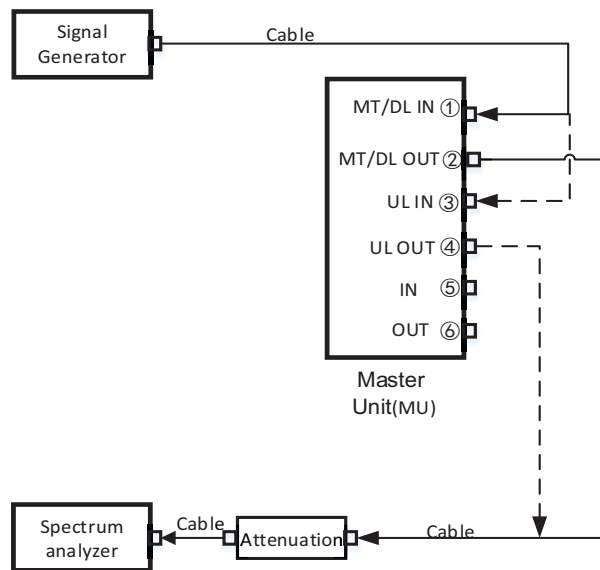

Figure 10.5-1 MU single device test connection diagram

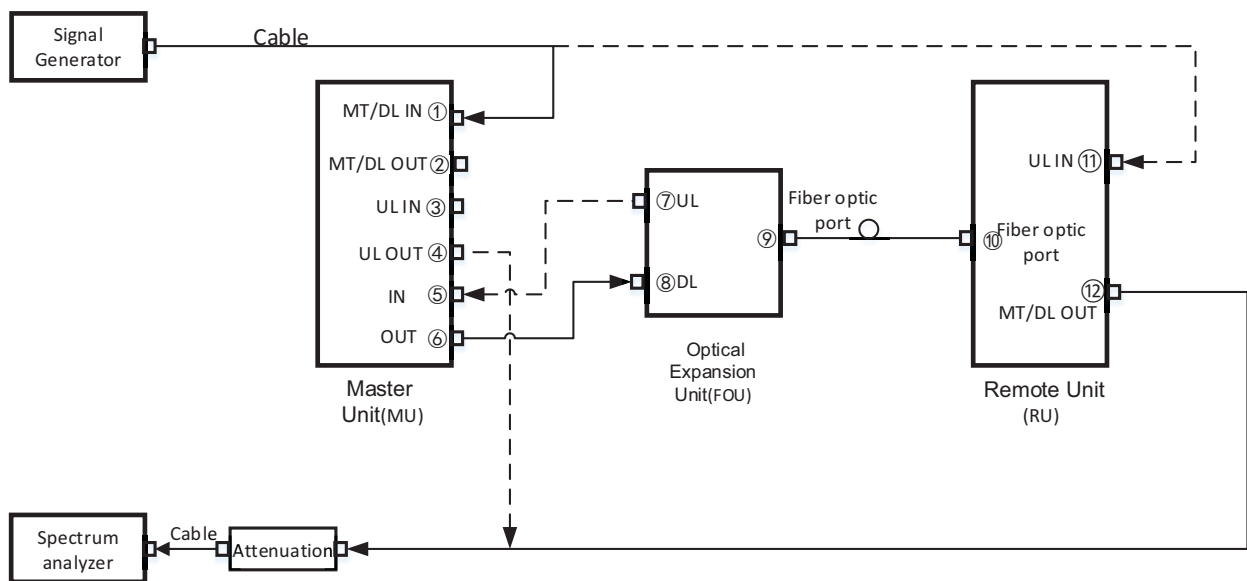

Figure 10.5-2 MU, FOU and RU system test connection diagram

----- The following blanks -----

10.5.3. Test procedures

- a) Connect a signal generator to the input of the EUT.
- b) Configure the signal generator to transmit the appropriate test signal associated with the public safety emission designation (see Table 1).
- c) Configure the signal level to be just below the AGC threshold (see results from 4.2).
- d) Connect a spectrum analyzer to the output of the EUT using appropriate attenuation as necessary.
- e) Set the spectrum analyzer center frequency to the nominal EUT channel center frequency. The span range for the spectrum analyzer shall be between $2 \times$ to $5 \times$ the EBW (or OBW).
- f) The nominal RBW shall be 300 Hz for 16K0F3E, and 100 Hz for all other emissions types.
- g) Set the reference level of the spectrum analyzer to accommodate the maximum input amplitude level, i.e., the level at f_0 per 4.3.
- h) Set spectrum analyzer detection mode to peak, and trace mode to max hold.
- i) Allow the trace to fully stabilize.
- j) Confirm that the signal is contained within the appropriate emissions mask.
- k) Use the marker function to determine the maximum emission level and record the associated frequency.
- l) Capture the emissions mask plot for inclusion in the test report (output signal spectra).
- m) Measure the EUT input signal power (signal generator output signal) directly from the signal generator using power measurement guidance provided in KDB Publication 971168 [R8] (input signal spectra).
- n) Compare the spectral plot of the output signal (determined in step k), to the input signal (determined in step l) to affirm they are similar (in passband and rolloff characteristic features and relative spectral locations).
- o) Repeat steps d) to n) with the input signal amplitude set 3 dB above the AGC threshold.
- p) Repeat steps b) to o) for all authorized operational bands and emissions types (see applicable regulatory specifications, e.g., Section 90.210).
- q) Include all accumulated spectral plots depicting EUT input signal and EUT output signal in the test report, and note any observed dissimilarities.

----- The following blanks -----

10.5.4. Test results

Test Date (yy-mm-dd): 2021-11-22 to 2021-12-09

Normal condition: Temp: 23.5~26.5°C, Humid:41~44%, Atmospheric Pressure:101kpa

Supply Voltage: DC -48V

10.5.4.1. Emission mask

10.5.4.1.1. MU single device test

10.5.4.1.1.1. P25 Phase I(C4FM) mode

Carrier frequency	Input signal status	Limit	Test Data	Result
(1) Downlink transmit mode				
Low frequency: 450.00625 MHz	with the input signal amplitude set the AGC threshold	Mask D	See clause 10.5.5.1.1.1.1	PASS
	with the input signal amplitude set 3 dB above the AGC threshold	Mask D	See clause 10.5.5.1.1.1.1	PASS
Mid frequency: 479.0 MHz	with the input signal amplitude set the AGC threshold	Mask D	See clause 10.5.5.1.1.1.1	PASS
	with the input signal amplitude set 3 dB above the AGC threshold	Mask D	See clause 10.5.5.1.1.1.1	PASS
High frequency: 508.99375MHz	with the input signal amplitude set the AGC threshold	Mask D	See clause 10.5.5.1.1.1.1	PASS
	with the input signal amplitude set 3 dB above the AGC threshold	Mask D	See clause 10.5.5.1.1.1.1	PASS
(2) Uplink transmit mode				
Low frequency: 455.00625 MHz	with the input signal amplitude set the AGC threshold	Mask D	See clause 10.5.5.1.1.2.1	PASS
	with the input signal amplitude set 3 dB above the AGC threshold	Mask D	See clause 10.5.5.1.1.2.1	PASS
Mid frequency: 484.0 MHz	with the input signal amplitude set the AGC threshold	Mask D	See clause 10.5.5.1.1.2.1	PASS
	with the input signal amplitude set 3 dB above the AGC threshold	Mask D	See clause 10.5.5.1.1.2.1	PASS
High frequency: 511.99375MHz	with the input signal amplitude set the AGC threshold	Mask D	See clause 10.5.5.1.1.2.1	PASS
	with the input signal amplitude set 3 dB above the AGC threshold	Mask D	See clause 10.5.5.1.1.2.1	PASS

10.5.4.1.1.2. P25 Phase II(H-DQPSK) mode

Carrier frequency	Input signal status	Limit	Test Data	Result
(3) Downlink transmit mode				
Low frequency: 450.00625 MHz	with the input signal amplitude set the AGC threshold	Mask D	See clause 10.5.5.1.1.1.2	PASS
	with the input signal amplitude set 3 dB above the AGC threshold	Mask D	See clause 10.5.5.1.1.1.2	PASS
Mid frequency: 479.0 MHz	with the input signal amplitude set the AGC threshold	Mask D	See clause 10.5.5.1.1.1.2	PASS
	with the input signal amplitude set 3 dB above the AGC threshold	Mask D	See clause 10.5.5.1.1.1.2	PASS
High frequency: 508.99375MHz	with the input signal amplitude set the AGC threshold	Mask D	See clause 10.5.5.1.1.1.2	PASS
	with the input signal amplitude set 3 dB above the AGC threshold	Mask D	See clause 10.5.5.1.1.1.2	PASS
(4) Uplink transmit mode				
Low frequency: 455.00625 MHz	with the input signal amplitude set the AGC threshold	Mask D	See clause 10.5.5.1.1.2.2	PASS
	with the input signal amplitude set 3 dB above the AGC threshold	Mask D	See clause 10.5.5.1.1.2.2	PASS
Mid frequency: 484.0 MHz	with the input signal amplitude set the AGC threshold	Mask D	See clause 10.5.5.1.1.2.2	PASS
	with the input signal amplitude set 3 dB above the AGC threshold	Mask D	See clause 10.5.5.1.1.2.2	PASS
High frequency: 511.99375MHz	with the input signal amplitude set the AGC threshold	Mask D	See clause 10.5.5.1.1.2.2	PASS
	with the input signal amplitude set 3 dB above the AGC threshold	Mask D	See clause 10.5.5.1.1.2.2	PASS

----- The following blanks -----

10.5.4.1.1.3. 6.25kHz Analog FM mode

Carrier frequency	Input signal status	Limit	Test Data	Result
(5) Downlink transmit mode				
Low frequency: 450.00313 MHz	with the input signal amplitude set the AGC threshold	Mask E	See clause 10.5.5.1.1.1.3	PASS
	with the input signal amplitude set 3 dB above the AGC threshold	Mask E	See clause 10.5.5.1.1.1.3	PASS
Mid frequency: 479.0 MHz	with the input signal amplitude set the AGC threshold	Mask E	See clause 10.5.5.1.1.1.3	PASS
	with the input signal amplitude set 3 dB above the AGC threshold	Mask E	See clause 10.5.5.1.1.1.3	PASS
High frequency: 508.99688MHz	with the input signal amplitude set the AGC threshold	Mask E	See clause 10.5.5.1.1.1.3	PASS
	with the input signal amplitude set 3 dB above the AGC threshold	Mask E	See clause 10.5.5.1.1.1.3	PASS
(6) Uplink transmit mode				
Low frequency: 455.00313 MHz	with the input signal amplitude set the AGC threshold	Mask E	See clause 10.5.5.1.1.2.3	PASS
	with the input signal amplitude set 3 dB above the AGC threshold	Mask E	See clause 10.5.5.1.1.2.3	PASS
Mid frequency: 484.0 MHz	with the input signal amplitude set the AGC threshold	Mask E	See clause 10.5.5.1.1.2.3	PASS
	with the input signal amplitude set 3 dB above the AGC threshold	Mask E	See clause 10.5.5.1.1.2.3	PASS
High frequency: 511.99688MHz	with the input signal amplitude set the AGC threshold	Mask E	See clause 10.5.5.1.1.2.3	PASS
	with the input signal amplitude set 3 dB above the AGC threshold	Mask E	See clause 10.5.5.1.1.2.3	PASS

----- The following blanks -----

10.5.4.1.1.4. 12.5kHz Analog FM mode

Carrier frequency	Input signal status	Limit	Test Data	Result
(7) Downlink transmit mode				
Low frequency: 450.00625 MHz	with the input signal amplitude set the AGC threshold	Mask D	See clause 10.5.5.1.1.1.4	PASS
	with the input signal amplitude set 3 dB above the AGC threshold	Mask D	See clause 10.5.5.1.1.1.4	PASS
Mid frequency: 479.0 MHz	with the input signal amplitude set the AGC threshold	Mask D	See clause 10.5.5.1.1.1.4	PASS
	with the input signal amplitude set 3 dB above the AGC threshold	Mask D	See clause 10.5.5.1.1.1.4	PASS
High frequency: 508.99375MHz	with the input signal amplitude set the AGC threshold	Mask D	See clause 10.5.5.1.1.1.4	PASS
	with the input signal amplitude set 3 dB above the AGC threshold	Mask D	See clause 10.5.5.1.1.1.4	PASS
(8) Uplink transmit mode				
Low frequency: 455.00625 MHz	with the input signal amplitude set the AGC threshold	Mask D	See clause 10.5.5.1.1.2.4	PASS
	with the input signal amplitude set 3 dB above the AGC threshold	Mask D	See clause 10.5.5.1.1.2.4	PASS
Mid frequency: 484.0 MHz	with the input signal amplitude set the AGC threshold	Mask D	See clause 10.5.5.1.1.2.4	PASS
	with the input signal amplitude set 3 dB above the AGC threshold	Mask D	See clause 10.5.5.1.1.2.4	PASS
High frequency: 511.99375MHz	with the input signal amplitude set the AGC threshold	Mask D	See clause 10.5.5.1.1.2.4	PASS
	with the input signal amplitude set 3 dB above the AGC threshold	Mask D	See clause 10.5.5.1.1.2.4	PASS

----- The following blanks -----

10.5.4.1.1.5. 25kHz Analog FM mode

Carrier frequency	Input signal status	Limit	Test Data	Result
(9) Downlink transmit mode				
Low frequency: 450.0125 MHz	with the input signal amplitude set the AGC threshold	Mask B+ Mask C	See clause 10.5.5.1.1.1.5	PASS
	with the input signal amplitude set 3 dB above the AGC threshold	Mask B+ Mask C	See clause 10.5.5.1.1.1.5	PASS
Mid frequency: 479.0 MHz	with the input signal amplitude set the AGC threshold	Mask B+ Mask C	See clause 10.5.5.1.1.1.5	PASS
	with the input signal amplitude set 3 dB above the AGC threshold	Mask B+ Mask C	See clause 10.5.5.1.1.1.5	PASS
High frequency: 508.9875MHz	with the input signal amplitude set the AGC threshold	Mask B+ Mask C	See clause 10.5.5.1.1.1.5	PASS
	with the input signal amplitude set 3 dB above the AGC threshold	Mask B+ Mask C	See clause 10.5.5.1.1.1.5	PASS
(10) Uplink transmit mode				
Low frequency: 455.0125 MHz	with the input signal amplitude set the AGC threshold	Mask B+ Mask C	See clause 10.5.5.1.1.2.5	PASS
	with the input signal amplitude set 3 dB above the AGC threshold	Mask B+ Mask C	See clause 10.5.5.1.1.2.5	PASS
Mid frequency: 484.0 MHz	with the input signal amplitude set the AGC threshold	Mask B+ Mask C	See clause 10.5.5.1.1.2.5	PASS
	with the input signal amplitude set 3 dB above the AGC threshold	Mask B+ Mask C	See clause 10.5.5.1.1.2.5	PASS
High frequency: 511.9875MHz	with the input signal amplitude set the AGC threshold	Mask B+ Mask C	See clause 10.5.5.1.1.2.5	PASS
	with the input signal amplitude set 3 dB above the AGC threshold	Mask B+ Mask C	See clause 10.5.5.1.1.2.5	PASS

----- The following blanks -----

10.5.4.1.2. System test

10.5.4.1.2.1. P25 Phase I(C4FM) mode

Carrier frequency	Input signal status	Limit	Test Data	Result
(11) Uplink transmit mode				
Low frequency: 455.00625 MHz	with the input signal amplitude set the AGC threshold	Mask D	See clause 10.5.5.1.2.1.1	PASS
	with the input signal amplitude set 3 dB above the AGC threshold	Mask D	See clause 10.5.5.1.2.1.1	PASS
Mid frequency: 484.0 MHz	with the input signal amplitude set the AGC threshold	Mask D	See clause 10.5.5.1.2.1.1	PASS
	with the input signal amplitude set 3 dB above the AGC threshold	Mask D	See clause 10.5.5.1.2.1.1	PASS
High frequency: 511.99375MHz	with the input signal amplitude set the AGC threshold	Mask D	See clause 10.5.5.1.2.1.1	PASS
	with the input signal amplitude set 3 dB above the AGC threshold	Mask D	See clause 10.5.5.1.2.1.1	PASS

10.5.4.1.2.2. P25 Phase II(H-DQPSK) mode

Carrier frequency	Input signal status	Limit	Test Data	Result
(12) Uplink transmit mode				
Low frequency: 455.00625 MHz	with the input signal amplitude set the AGC threshold	Mask D	See clause 10.5.5.1.2.1.2	PASS
	with the input signal amplitude set 3 dB above the AGC threshold	Mask D	See clause 10.5.5.1.2.1.2	PASS
Mid frequency: 484.0 MHz	with the input signal amplitude set the AGC threshold	Mask D	See clause 10.5.5.1.2.1.2	PASS
	with the input signal amplitude set 3 dB above the AGC threshold	Mask D	See clause 10.5.5.1.2.1.2	PASS
High frequency: 511.99375MHz	with the input signal amplitude set the AGC threshold	Mask D	See clause 10.5.5.1.2.1.2	PASS
	with the input signal amplitude set 3 dB above the AGC threshold	Mask D	See clause 10.5.5.1.2.1.2	PASS

10.5.4.1.2.3. 6.25kHz Analog FM mode

Carrier frequency	Input signal status	Limit	Test Data	Result
(13) Uplink transmit mode				
Low frequency: 455.00313 MHz	with the input signal amplitude set the AGC threshold	Mask E	See clause 10.5.5.1.2.1.3	PASS
	with the input signal amplitude set 3 dB above the AGC threshold	Mask E	See clause 10.5.5.1.2.1.3	PASS
Mid frequency: 484.0 MHz	with the input signal amplitude set the AGC threshold	Mask E	See clause 10.5.5.1.2.1.3	PASS
	with the input signal amplitude set 3 dB above the AGC threshold	Mask E	See clause 10.5.5.1.2.1.3	PASS
High frequency: 511.99688MHz	with the input signal amplitude set the AGC threshold	Mask E	See clause 10.5.5.1.2.1.3	PASS
	with the input signal amplitude set 3 dB above the AGC threshold	Mask E	See clause 10.5.5.1.2.1.3	PASS

10.5.4.1.2.4. 12.5kHz Analog FM mode

Carrier frequency	Input signal status	Limit	Test Data	Result
(14) Uplink transmit mode				
Low frequency: 455.00625 MHz	with the input signal amplitude set the AGC threshold	Mask D	See clause 10.5.5.1.2.1.4	PASS
	with the input signal amplitude set 3 dB above the AGC threshold	Mask D	See clause 10.5.5.1.2.1.4	PASS
Mid frequency: 484.0 MHz	with the input signal amplitude set the AGC threshold	Mask D	See clause 10.5.5.1.2.1.4	PASS
	with the input signal amplitude set 3 dB above the AGC threshold	Mask D	See clause 10.5.5.1.2.1.4	PASS
High frequency: 511.99375MHz	with the input signal amplitude set the AGC threshold	Mask D	See clause 10.5.5.1.2.1.4	PASS
	with the input signal amplitude set 3 dB above the AGC threshold	Mask D	See clause 10.5.5.1.2.1.4	PASS

10.5.4.1.2.5. 25kHz Analog FM mode

Carrier frequency	Input signal status	Limit	Test Data	Result
(15) Uplink transmit mode				
Low frequency: 455.0125 MHz	with the input signal amplitude set the AGC threshold	Mask B+ Mask C	See clause 10.5.5.1.2.1.5	PASS
	with the input signal amplitude set 3 dB above the AGC threshold	Mask B+ Mask C	See clause 10.5.5.1.2.1.5	PASS
Mid frequency: 484.0 MHz	with the input signal amplitude set the AGC threshold	Mask B+ Mask C	See clause 10.5.5.1.2.1.5	PASS
	with the input signal amplitude set 3 dB above the AGC threshold	Mask B+ Mask C	See clause 10.5.5.1.2.1.5	PASS
High frequency: 511.9875MHz	with the input signal amplitude set the AGC threshold	Mask B+ Mask C	See clause 10.5.5.1.2.1.5	PASS
	with the input signal amplitude set 3 dB above the AGC threshold	Mask B+ Mask C	See clause 10.5.5.1.2.1.5	PASS

----- The following blanks -----

10.5.4.2. Occupied bandwidth

10.5.4.2.1. MU single device test

10.5.4.2.1.1. P25 Phase I(C4FM) mode

Carrier frequency	Input signal status	Test Data
(16) Downlink transmit mode		
Low frequency: 450.00625 MHz	with the input signal amplitude set the AGC threshold	See clause 10.5.5.2.1.1.1
	with the input signal amplitude set 3 dB above the AGC threshold	See clause 10.5.5.2.1.1.1
Mid frequency: 479.0 MHz	with the input signal amplitude set the AGC threshold	See clause 10.5.5.2.1.1.1
	with the input signal amplitude set 3 dB above the AGC threshold	See clause 10.5.5.2.1.1.1
High frequency: 508.99375MHz	with the input signal amplitude set the AGC threshold	See clause 10.5.5.2.1.1.1
	with the input signal amplitude set 3 dB above the AGC threshold	See clause 10.5.5.2.1.1.1
(17) Uplink transmit mode		
Low frequency: 455.00625 MHz	with the input signal amplitude set the AGC threshold	See clause 10.5.5.2.1.2.1
	with the input signal amplitude set 3 dB above the AGC threshold	See clause 10.5.5.2.1.2.1
Mid frequency: 484.0 MHz	with the input signal amplitude set the AGC threshold	See clause 10.5.5.2.1.2.1
	with the input signal amplitude set 3 dB above the AGC threshold	See clause 10.5.5.2.1.2.1
High frequency: 511.99375MHz	with the input signal amplitude set the AGC threshold	See clause 10.5.5.2.1.2.1
	with the input signal amplitude set 3 dB above the AGC threshold	See clause 10.5.5.2.1.2.1

----- The following blanks -----

10.5.4.2.1.2. P25 Phase II(H-DQPSK) mode

Carrier frequency	Input signal status	Test Data
(18) Downlink transmit mode		
Low frequency: 450.00625 MHz	with the input signal amplitude set the AGC threshold	See clause 10.5.5.2.1.1.2
	with the input signal amplitude set 3 dB above the AGC threshold	See clause 10.5.5.2.1.1.2
Mid frequency: 479.0 MHz	with the input signal amplitude set the AGC threshold	See clause 10.5.5.2.1.1.2
	with the input signal amplitude set 3 dB above the AGC threshold	See clause 10.5.5.2.1.1.2
High frequency: 508.99375MHz	with the input signal amplitude set the AGC threshold	See clause 10.5.5.2.1.1.2
	with the input signal amplitude set 3 dB above the AGC threshold	See clause 10.5.5.2.1.1.2
(19) Uplink transmit mode		
Low frequency: 455.00625 MHz	with the input signal amplitude set the AGC threshold	See clause 10.5.5.2.1.2.2
	with the input signal amplitude set 3 dB above the AGC threshold	See clause 10.5.5.2.1.2.2
Mid frequency: 484.0 MHz	with the input signal amplitude set the AGC threshold	See clause 10.5.5.2.1.2.2
	with the input signal amplitude set 3 dB above the AGC threshold	See clause 10.5.5.2.1.2.2
High frequency: 511.99375MHz	with the input signal amplitude set the AGC threshold	See clause 10.5.5.2.1.2.2
	with the input signal amplitude set 3 dB above the AGC threshold	See clause 10.5.5.2.1.2.2

----- The following blanks -----

10.5.4.2.1.3. 6.25kHz Analog FM mode

Carrier frequency	Input signal status	Test Data
(20) Downlink transmit mode		
Low frequency: 450.00313 MHz	with the input signal amplitude set the AGC threshold	See clause 10.5.5.2.1.1.3
	with the input signal amplitude set 3 dB above the AGC threshold	See clause 10.5.5.2.1.1.3
Mid frequency: 479.0 MHz	with the input signal amplitude set the AGC threshold	See clause 10.5.5.2.1.1.3
	with the input signal amplitude set 3 dB above the AGC threshold	See clause 10.5.5.2.1.1.3
High frequency: 508.99688MHz	with the input signal amplitude set the AGC threshold	See clause 10.5.5.2.1.1.3
	with the input signal amplitude set 3 dB above the AGC threshold	See clause 10.5.5.2.1.1.3
(21) Uplink transmit mode		
Low frequency: 455.00313 MHz	with the input signal amplitude set the AGC threshold	See clause 10.5.5.2.1.2.3
	with the input signal amplitude set 3 dB above the AGC threshold	See clause 10.5.5.2.1.2.3
Mid frequency: 484.0 MHz	with the input signal amplitude set the AGC threshold	See clause 10.5.5.2.1.2.3
	with the input signal amplitude set 3 dB above the AGC threshold	See clause 10.5.5.2.1.2.3
High frequency: 511.99688MHz	with the input signal amplitude set the AGC threshold	See clause 10.5.5.2.1.2.3
	with the input signal amplitude set 3 dB above the AGC threshold	See clause 10.5.5.2.1.2.3

----- The following blanks -----

10.5.4.2.1.4. 12.5kHz Analog FM mode

Carrier frequency	Input signal status	Test Data
(22) Downlink transmit mode		
Low frequency: 450.00625 MHz	with the input signal amplitude set the AGC threshold	See clause 10.5.5.2.1.1.4
	with the input signal amplitude set 3 dB above the AGC threshold	See clause 10.5.5.2.1.1.4
Mid frequency: 479.0 MHz	with the input signal amplitude set the AGC threshold	See clause 10.5.5.2.1.1.4
	with the input signal amplitude set 3 dB above the AGC threshold	See clause 10.5.5.2.1.1.4
High frequency: 508.99375MHz	with the input signal amplitude set the AGC threshold	See clause 10.5.5.2.1.1.4
	with the input signal amplitude set 3 dB above the AGC threshold	See clause 10.5.5.2.1.1.4
(23) Uplink transmit mode		
Low frequency: 455.00625 MHz	with the input signal amplitude set the AGC threshold	See clause 10.5.5.2.1.2.4
	with the input signal amplitude set 3 dB above the AGC threshold	See clause 10.5.5.2.1.2.4
Mid frequency: 484.0 MHz	with the input signal amplitude set the AGC threshold	See clause 10.5.5.2.1.2.4
	with the input signal amplitude set 3 dB above the AGC threshold	See clause 10.5.5.2.1.2.4
High frequency: 511.99375MHz	with the input signal amplitude set the AGC threshold	See clause 10.5.5.2.1.2.4
	with the input signal amplitude set 3 dB above the AGC threshold	See clause 10.5.5.2.1.2.4

----- The following blanks -----

10.5.4.2.1.5. 25kHz Analog FM mode

Carrier frequency	Input signal status	Test Data
(24) Downlink transmit mode		
Low frequency: 450.0125 MHz	with the input signal amplitude set the AGC threshold	See clause 10.5.5.2.1.1.5
	with the input signal amplitude set 3 dB above the AGC threshold	See clause 10.5.5.2.1.1.5
Mid frequency: 479.0 MHz	with the input signal amplitude set the AGC threshold	See clause 10.5.5.2.1.1.5
	with the input signal amplitude set 3 dB above the AGC threshold	See clause 10.5.5.2.1.1.5
High frequency: 508.9875MHz	with the input signal amplitude set the AGC threshold	See clause 10.5.5.2.1.1.5
	with the input signal amplitude set 3 dB above the AGC threshold	See clause 10.5.5.2.1.1.5
(25) Uplink transmit mode		
Low frequency: 455.0125 MHz	with the input signal amplitude set the AGC threshold	See clause 10.5.5.2.1.2.5
	with the input signal amplitude set 3 dB above the AGC threshold	See clause 10.5.5.2.1.2.5
Mid frequency: 484.0 MHz	with the input signal amplitude set the AGC threshold	See clause 10.5.5.2.1.2.5
	with the input signal amplitude set 3 dB above the AGC threshold	See clause 10.5.5.2.1.2.5
High frequency: 511.9875MHz	with the input signal amplitude set the AGC threshold	See clause 10.5.5.2.1.2.5
	with the input signal amplitude set 3 dB above the AGC threshold	See clause 10.5.5.2.1.2.5

----- The following blanks -----

10.5.4.2.2. System test

10.5.4.2.2.1. P25 Phase I(C4FM) mode

Carrier frequency	Input signal status	Test Data
(26) Uplink transmit mode		
Low frequency: 455.00625 MHz	with the input signal amplitude set the AGC threshold	See clause 10.5.5.2.2.1.1
	with the input signal amplitude set 3 dB above the AGC threshold	See clause 10.5.5.2.2.1.1
Mid frequency: 484.0 MHz	with the input signal amplitude set the AGC threshold	See clause 10.5.5.2.2.1.1
	with the input signal amplitude set 3 dB above the AGC threshold	See clause 10.5.5.2.2.1.1
High frequency: 511.99375MHz	with the input signal amplitude set the AGC threshold	See clause 10.5.5.2.2.1.1
	with the input signal amplitude set 3 dB above the AGC threshold	See clause 10.5.5.2.2.1.1

10.5.4.2.2.2. P25 Phase II(H-DQPSK) mode

Carrier frequency	Input signal status	Test Data
(27) Uplink transmit mode		
Low frequency: 455.00625 MHz	with the input signal amplitude set the AGC threshold	See clause 10.5.5.2.2.1.2
	with the input signal amplitude set 3 dB above the AGC threshold	See clause 10.5.5.2.2.1.2
Mid frequency: 484.0 MHz	with the input signal amplitude set the AGC threshold	See clause 10.5.5.2.2.1.2
	with the input signal amplitude set 3 dB above the AGC threshold	See clause 10.5.5.2.2.1.2
High frequency: 511.99375MHz	with the input signal amplitude set the AGC threshold	See clause 10.5.5.2.2.1.2
	with the input signal amplitude set 3 dB above the AGC threshold	See clause 10.5.5.2.2.1.2

10.5.4.2.2.3. 6.25kHz Analog FM mode

Carrier frequency	Input signal status	Test Data
(28) Uplink transmit mode		
Low frequency: 455.00313 MHz	with the input signal amplitude set the AGC threshold	See clause 10.5.5.2.2.1.3
	with the input signal amplitude set 3 dB above the AGC threshold	See clause 10.5.5.2.2.1.3
Mid frequency: 484.0 MHz	with the input signal amplitude set the AGC threshold	See clause 10.5.5.2.2.1.3
	with the input signal amplitude set 3 dB above the AGC threshold	See clause 10.5.5.2.2.1.3
High frequency: 511.99688MHz	with the input signal amplitude set the AGC threshold	See clause 10.5.5.2.2.1.3
	with the input signal amplitude set 3 dB above the AGC threshold	See clause 10.5.5.2.2.1.3

10.5.4.2.2.4. 12.5kHz Analog FM mode

Carrier frequency	Input signal status	Test Data
(29) Uplink transmit mode		
Low frequency: 455.00625 MHz	with the input signal amplitude set the AGC threshold	See clause 10.5.5.2.2.1.4
	with the input signal amplitude set 3 dB above the AGC threshold	See clause 10.5.5.2.2.1.4
Mid frequency: 484.0 MHz	with the input signal amplitude set the AGC threshold	See clause 10.5.5.2.2.1.4
	with the input signal amplitude set 3 dB above the AGC threshold	See clause 10.5.5.2.2.1.4
High frequency: 511.99375MHz	with the input signal amplitude set the AGC threshold	See clause 10.5.5.2.2.1.4
	with the input signal amplitude set 3 dB above the AGC threshold	See clause 10.5.5.2.2.1.4

10.5.4.2.2.5. 25kHz Analog FM mode

Carrier frequency	Input signal status	Test Data
(30) Uplink transmit mode		
Low frequency: 455.0125 MHz	with the input signal amplitude set the AGC threshold	See clause 10.5.5.2.2.1.5
	with the input signal amplitude set 3 dB above the AGC threshold	See clause 10.5.5.2.2.1.5
Mid frequency: 484.0 MHz	with the input signal amplitude set the AGC threshold	See clause 10.5.5.2.2.1.5
	with the input signal amplitude set 3 dB above the AGC threshold	See clause 10.5.5.2.2.1.5
High frequency: 511.9875MHz	with the input signal amplitude set the AGC threshold	See clause 10.5.5.2.2.1.5
	with the input signal amplitude set 3 dB above the AGC threshold	See clause 10.5.5.2.2.1.5

----- The following blanks -----

10.5.4.3. Input VS output Comparison

10.5.4.3.1. MU single device test

10.5.4.3.1.1. P25 Phase I(C4FM) mode

Carrier frequency	Input VS output Comparison status	Test data
(1) Downlink transmit mode		
Low frequency: 450.00625 MHz	Input signal	See clause 10.5.5.3.1.1.1
	with the input signal amplitude set the AGC threshold	See clause 10.5.5.3.1.1.1
	with the input signal amplitude set 3 dB above the AGC threshold	See clause 10.5.5.3.1.1.1
Mid frequency: 479.0 MHz	Input signal	See clause 10.5.5.3.1.1.1
	with the input signal amplitude set the AGC threshold	See clause 10.5.5.3.1.1.1
	with the input signal amplitude set 3 dB above the AGC threshold	See clause 10.5.5.3.1.1.1
High frequency: 508.99375MHz	Input signal	See clause 10.5.5.3.1.1.1
	with the input signal amplitude set the AGC threshold	See clause 10.5.5.3.1.1.1
	with the input signal amplitude set 3 dB above the AGC threshold	See clause 10.5.5.3.1.1.1
(2) Uplink transmit mode		
Low frequency: 450.00625 MHz	Input signal	See clause 10.5.5.3.1.2.1
	with the input signal amplitude set the AGC threshold	See clause 10.5.5.3.1.2.1
	with the input signal amplitude set 3 dB above the AGC threshold	See clause 10.5.5.3.1.2.1
Mid frequency: 479.0 MHz	Input signal	See clause 10.5.5.3.1.2.1
	with the input signal amplitude set the AGC threshold	See clause 10.5.5.3.1.2.1
	with the input signal amplitude set 3 dB above the AGC threshold	See clause 10.5.5.3.1.2.1
High frequency: 508.99375MHz	Input signal	See clause 10.5.5.3.1.2.1
	with the input signal amplitude set the AGC threshold	See clause 10.5.5.3.1.2.1
	with the input signal amplitude set 3 dB above the AGC threshold	See clause 10.5.5.3.1.2.1

----- The following blanks -----

10.5.4.3.1.2. P25 Phase II(H-DQPSK) mode

Carrier frequency	Input VS output Comparison status	Test data
(3) Downlink transmit mode		
Low frequency: 450.00625 MHz	Input signal	See clause 10.5.5.3.1.1.2
	with the input signal amplitude set the AGC threshold	See clause 10.5.5.3.1.1.2
	with the input signal amplitude set 3 dB above the AGC threshold	See clause 10.5.5.3.1.1.2
Mid frequency: 479.0 MHz	Input signal	See clause 10.5.5.3.1.1.2
	with the input signal amplitude set the AGC threshold	See clause 10.5.5.3.1.1.2
	with the input signal amplitude set 3 dB above the AGC threshold	See clause 10.5.5.3.1.1.2
High frequency: 508.99375MHz	Input signal	See clause 10.5.5.3.1.1.2
	with the input signal amplitude set the AGC threshold	See clause 10.5.5.3.1.1.2
	with the input signal amplitude set 3 dB above the AGC threshold	See clause 10.5.5.3.1.1.2
(4) Uplink transmit mode		
Low frequency: 450.00625 MHz	Input signal	See clause 10.5.5.3.1.2.2
	with the input signal amplitude set the AGC threshold	See clause 10.5.5.3.1.2.2
	with the input signal amplitude set 3 dB above the AGC threshold	See clause 10.5.5.3.1.2.2
Mid frequency: 479.0 MHz	Input signal	See clause 10.5.5.3.1.2.2
	with the input signal amplitude set the AGC threshold	See clause 10.5.5.3.1.2.2
	with the input signal amplitude set 3 dB above the AGC threshold	See clause 10.5.5.3.1.2.2
High frequency: 508.99375MHz	Input signal	See clause 10.5.5.3.1.2.2
	with the input signal amplitude set the AGC threshold	See clause 10.5.5.3.1.2.2
	with the input signal amplitude set 3 dB above the AGC threshold	See clause 10.5.5.3.1.2.2

----- The following blanks -----

10.5.4.3.1.3. 6.25kHz Analog FM mode

Carrier frequency	Input VS output Comparison status	Test data
(5) Downlink transmit mode		
Low frequency: 450.00313 MHz	Input signal	See clause 10.5.5.3.1.1.3
	with the input signal amplitude set the AGC threshold	See clause 10.5.5.3.1.1.3
	with the input signal amplitude set 3 dB above the AGC threshold	See clause 10.5.5.3.1.1.3
Mid frequency: 479.0 MHz	Input signal	See clause 10.5.5.3.1.1.3
	with the input signal amplitude set the AGC threshold	See clause 10.5.5.3.1.1.3
	with the input signal amplitude set 3 dB above the AGC threshold	See clause 10.5.5.3.1.1.3
High frequency: 508.99688MHz	Input signal	See clause 10.5.5.3.1.1.3
	with the input signal amplitude set the AGC threshold	See clause 10.5.5.3.1.1.3
	with the input signal amplitude set 3 dB above the AGC threshold	See clause 10.5.5.3.1.1.3
(6) Uplink transmit mode		
Low frequency: 455.00313 MHz	Input signal	See clause 10.5.5.3.1.2.3
	with the input signal amplitude set the AGC threshold	See clause 10.5.5.3.1.2.3
	with the input signal amplitude set 3 dB above the AGC threshold	See clause 10.5.5.3.1.2.3
Mid frequency: 484.0 MHz	Input signal	See clause 10.5.5.3.1.2.3
	with the input signal amplitude set the AGC threshold	See clause 10.5.5.3.1.2.3
	with the input signal amplitude set 3 dB above the AGC threshold	See clause 10.5.5.3.1.2.3
High frequency: 511.99688MHz	Input signal	See clause 10.5.5.3.1.2.3
	with the input signal amplitude set the AGC threshold	See clause 10.5.5.3.1.2.3
	with the input signal amplitude set 3 dB above the AGC threshold	See clause 10.5.5.3.1.2.3

----- The following blanks -----

10.5.4.3.1.4. 12.5kHz Analog FM mode

Carrier frequency	Input VS output Comparison status	Test data
(7) Downlink transmit mode		
Low frequency: 450.00625 MHz	Input signal	See clause 10.5.5.3.1.1.4
	with the input signal amplitude set the AGC threshold	See clause 10.5.5.3.1.1.4
	with the input signal amplitude set 3 dB above the AGC threshold	See clause 10.5.5.3.1.1.4
Mid frequency: 479.0 MHz	Input signal	See clause 10.5.5.3.1.1.4
	with the input signal amplitude set the AGC threshold	See clause 10.5.5.3.1.1.4
	with the input signal amplitude set 3 dB above the AGC threshold	See clause 10.5.5.3.1.1.4
High frequency: 508.99375MHz	Input signal	See clause 10.5.5.3.1.1.4
	with the input signal amplitude set the AGC threshold	See clause 10.5.5.3.1.1.4
	with the input signal amplitude set 3 dB above the AGC threshold	See clause 10.5.5.3.1.1.4
(8) Uplink transmit mode		
Low frequency: 450.00625 MHz	Input signal	See clause 10.5.5.3.1.2.4
	with the input signal amplitude set the AGC threshold	See clause 10.5.5.3.1.2.4
	with the input signal amplitude set 3 dB above the AGC threshold	See clause 10.5.5.3.1.2.4
Mid frequency: 479.0 MHz	Input signal	See clause 10.5.5.3.1.2.4
	with the input signal amplitude set the AGC threshold	See clause 10.5.5.3.1.2.4
	with the input signal amplitude set 3 dB above the AGC threshold	See clause 10.5.5.3.1.2.4
High frequency: 508.99375MHz	Input signal	See clause 10.5.5.3.1.2.4
	with the input signal amplitude set the AGC threshold	See clause 10.5.5.3.1.2.4
	with the input signal amplitude set 3 dB above the AGC threshold	See clause 10.5.5.3.1.2.4

----- The following blanks -----

10.5.4.3.1.5. 25kHz Analog FM mode

Carrier frequency	Input VS output Comparison status	Test data
(9) Downlink transmit mode		
Low frequency: 450.00625 MHz	Input signal	See clause 10.5.5.3.1.1.5
	with the input signal amplitude set the AGC threshold	See clause 10.5.5.3.1.1.5
	with the input signal amplitude set 3 dB above the AGC threshold	See clause 10.5.5.3.1.1.5
Mid frequency: 479.0 MHz	Input signal	See clause 10.5.5.3.1.1.5
	with the input signal amplitude set the AGC threshold	See clause 10.5.5.3.1.1.5
	with the input signal amplitude set 3 dB above the AGC threshold	See clause 10.5.5.3.1.1.5
High frequency: 508.99375MHz	Input signal	See clause 10.5.5.3.1.1.5
	with the input signal amplitude set the AGC threshold	See clause 10.5.5.3.1.1.5
	with the input signal amplitude set 3 dB above the AGC threshold	See clause 10.5.5.3.1.1.5
(10) Uplink transmit mode		
Low frequency: 450.00625 MHz	Input signal	See clause 10.5.5.3.1.2.5
	with the input signal amplitude set the AGC threshold	See clause 10.5.5.3.1.2.5
	with the input signal amplitude set 3 dB above the AGC threshold	See clause 10.5.5.3.1.2.5
Mid frequency: 479.0 MHz	Input signal	See clause 10.5.5.3.1.2.5
	with the input signal amplitude set the AGC threshold	See clause 10.5.5.3.1.2.5
	with the input signal amplitude set 3 dB above the AGC threshold	See clause 10.5.5.3.1.2.5
High frequency: 508.99375MHz	Input signal	See clause 10.5.5.3.1.2.5
	with the input signal amplitude set the AGC threshold	See clause 10.5.5.3.1.2.5
	with the input signal amplitude set 3 dB above the AGC threshold	See clause 10.5.5.3.1.2.5

----- The following blanks -----

10.5.4.3.2. System test

10.5.4.3.2.1. P25 Phase I(C4FM) mode

Carrier frequency	Input VS output Comparison status	Test data
(11) Uplink transmit mode		
Low frequency: 450.00625 MHz	Input signal	See clause 10.5.5.3.2.1.1
	with the input signal amplitude set the AGC threshold	See clause 10.5.5.3.2.1.1
	with the input signal amplitude set 3 dB above the AGC threshold	See clause 10.5.5.3.2.1.1
Mid frequency: 479.0 MHz	Input signal	See clause 10.5.5.3.2.1.1
	with the input signal amplitude set the AGC threshold	See clause 10.5.5.3.2.1.1
	with the input signal amplitude set 3 dB above the AGC threshold	See clause 10.5.5.3.2.1.1
High frequency: 508.99375MHz	Input signal	See clause 10.5.5.3.2.1.1
	with the input signal amplitude set the AGC threshold	See clause 10.5.5.3.2.1.1
	with the input signal amplitude set 3 dB above the AGC threshold	See clause 10.5.5.3.2.1.1

10.5.4.3.2.2. P25 Phase II(H-DQPSK) mode

Carrier frequency	Input VS output Comparison status	Test data
(12) Uplink transmit mode		
Low frequency: 450.00625 MHz	Input signal	See clause 10.5.5.3.2.1.2
	with the input signal amplitude set the AGC threshold	See clause 10.5.5.3.2.1.2
	with the input signal amplitude set 3 dB above the AGC threshold	See clause 10.5.5.3.2.1.2
Mid frequency: 479.0 MHz	Input signal	See clause 10.5.5.3.2.1.2
	with the input signal amplitude set the AGC threshold	See clause 10.5.5.3.2.1.2
	with the input signal amplitude set 3 dB above the AGC threshold	See clause 10.5.5.3.2.1.2
High frequency: 508.99375MHz	Input signal	See clause 10.5.5.3.2.1.2
	with the input signal amplitude set the AGC threshold	See clause 10.5.5.3.2.1.2
	with the input signal amplitude set 3 dB above the AGC threshold	See clause 10.5.5.3.2.1.2

10.5.4.3.2.3. 6.25kHz Analog FM mode

Carrier frequency	Input VS output Comparison status	Test data
(13) Uplink transmit mode		
Low frequency: 450.00313 MHz	Input signal	See clause 10.5.5.3.2.1.3
	with the input signal amplitude set the AGC threshold	See clause 10.5.5.3.2.1.3
	with the input signal amplitude set 3 dB above the AGC threshold	See clause 10.5.5.3.2.1.3
Mid frequency: 479.0 MHz	Input signal	See clause 10.5.5.3.2.1.3
	with the input signal amplitude set the AGC threshold	See clause 10.5.5.3.2.1.3
	with the input signal amplitude set 3 dB above the AGC threshold	See clause 10.5.5.3.2.1.3
High frequency: 508.99688MHz	Input signal	See clause 10.5.5.3.2.1.3
	with the input signal amplitude set the AGC threshold	See clause 10.5.5.3.2.1.3
	with the input signal amplitude set 3 dB above the AGC threshold	See clause 10.5.5.3.2.1.3

10.5.4.3.2.4. 12.5kHz Analog FM mode

Carrier frequency	Input VS output Comparison status	Test data
(14) Uplink transmit mode		
Low frequency: 455.00313 MHz	Input signal	See clause 10.5.5.3.2.1.4
	with the input signal amplitude set the AGC threshold	See clause 10.5.5.3.2.1.4
	with the input signal amplitude set 3 dB above the AGC threshold	See clause 10.5.5.3.2.1.4
Mid frequency: 484.0 MHz	Input signal	See clause 10.5.5.3.2.1.4
	with the input signal amplitude set the AGC threshold	See clause 10.5.5.3.2.1.4
	with the input signal amplitude set 3 dB above the AGC threshold	See clause 10.5.5.3.2.1.4
High frequency: 511.99688MHz	Input signal	See clause 10.5.5.3.2.1.4
	with the input signal amplitude set the AGC threshold	See clause 10.5.5.3.2.1.4
	with the input signal amplitude set 3 dB above the AGC threshold	See clause 10.5.5.3.2.1.4

10.5.4.3.2.5. 25kHz Analog FM mode

Carrier frequency	Input VS output Comparison status	Test data
(15) Uplink transmit mode		
Low frequency: 450.00625 MHz	Input signal	See clause 10.5.5.3.2.1.5
	with the input signal amplitude set the AGC threshold	See clause 10.5.5.3.2.1.5
	with the input signal amplitude set 3 dB above the AGC threshold	See clause 10.5.5.3.2.1.5
Mid frequency: 479.0 MHz	Input signal	See clause 10.5.5.3.2.1.5
	with the input signal amplitude set the AGC threshold	See clause 10.5.5.3.2.1.5
	with the input signal amplitude set 3 dB above the AGC threshold	See clause 10.5.5.3.2.1.5
High frequency: 508.99375MHz	Input signal	See clause 10.5.5.3.2.1.5
	with the input signal amplitude set the AGC threshold	See clause 10.5.5.3.2.1.5
	with the input signal amplitude set 3 dB above the AGC threshold	See clause 10.5.5.3.2.1.5

----- The following blanks -----

10.5.5. Test screenshot

10.5.5.1. Emission mask

10.5.5.1.1. MU single device test

10.5.5.1.1.1. Downlink

10.5.5.1.1.1.1. P25 Phase I(C4FM) mode

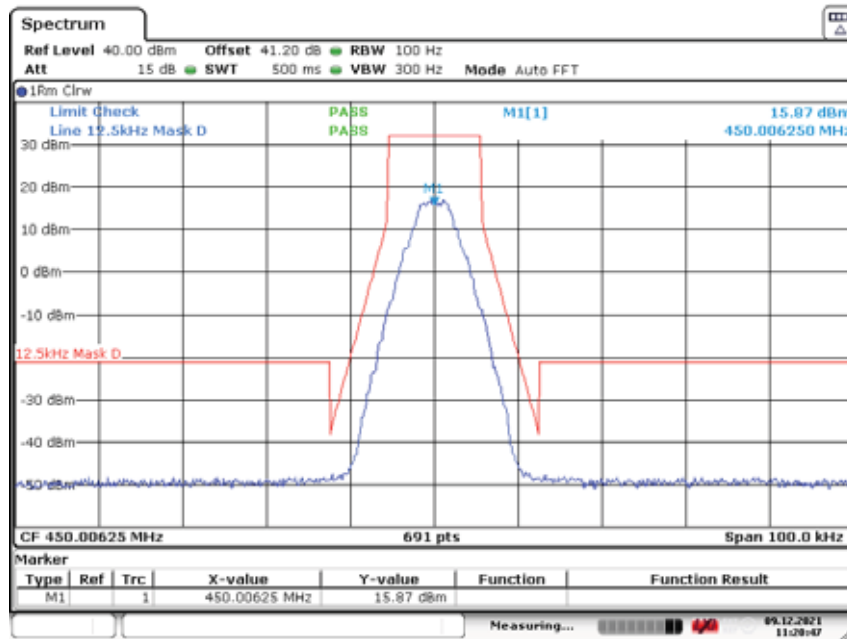

Date: 9 DEC 2021 11:20:47

With the input signal amplitude set the AGC threshold
Low Frequency: 450.00625MHz

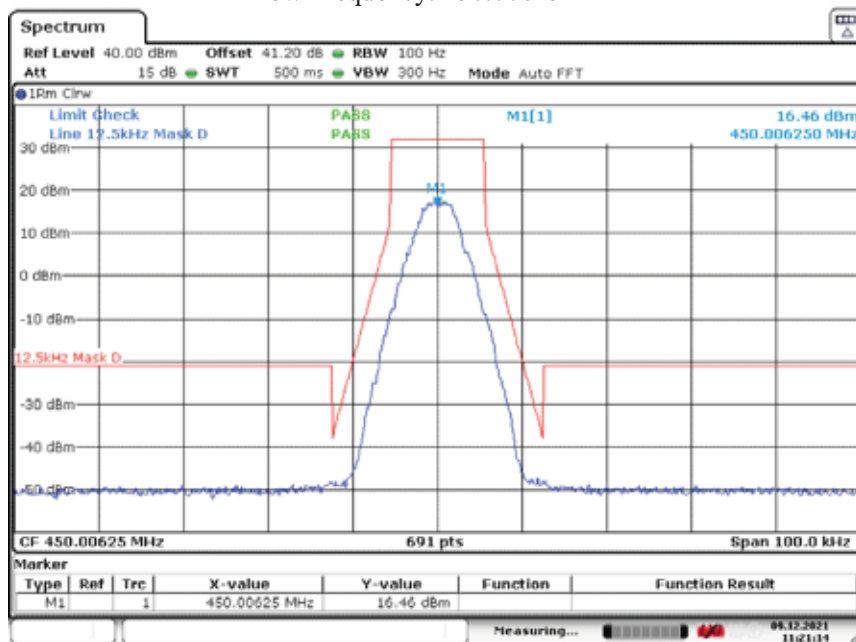

Date: 9 DEC 2021 11:21:14

With the input signal amplitude set 3 dB above the AGC threshold
Low Frequency: 450.00625MHz

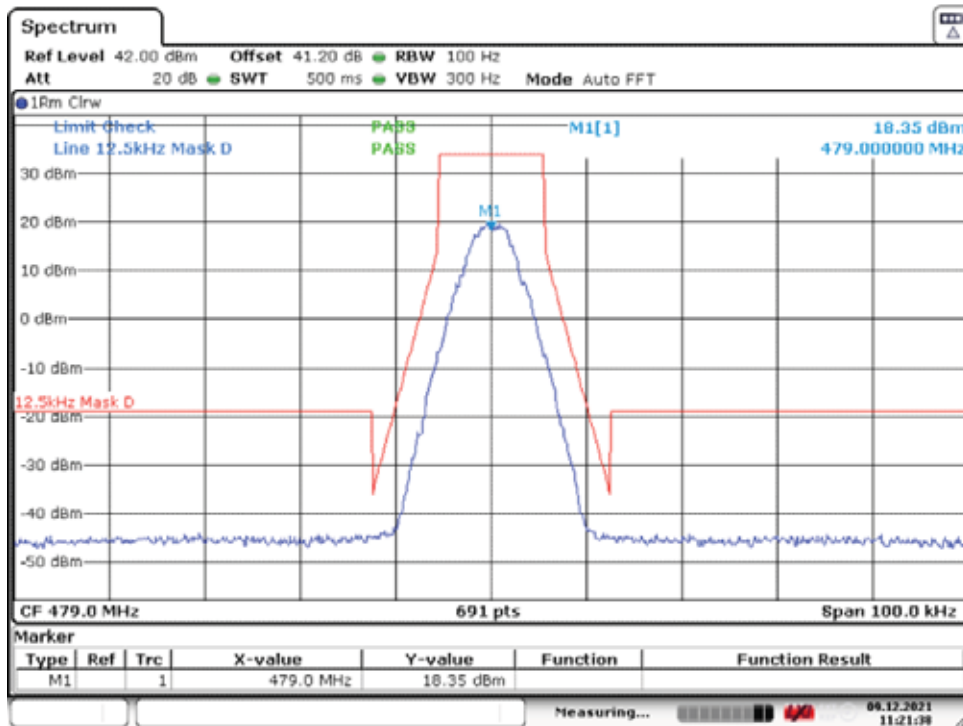

Date: 9.DEC.2021 11:21:38

With the input signal amplitude set the AGC threshold
 Middle Frequency: 479.0MHz

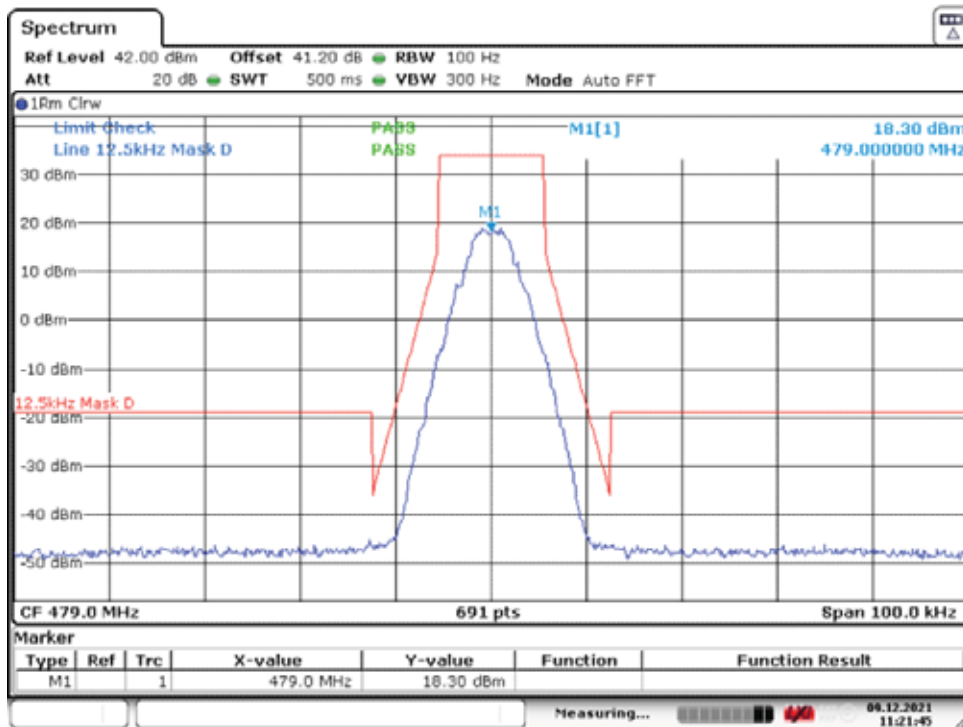

Date: 9.DEC.2021 11:21:45

With the input signal amplitude set 3 dB above the AGC threshold
 Middle Frequency: 479.0MHz

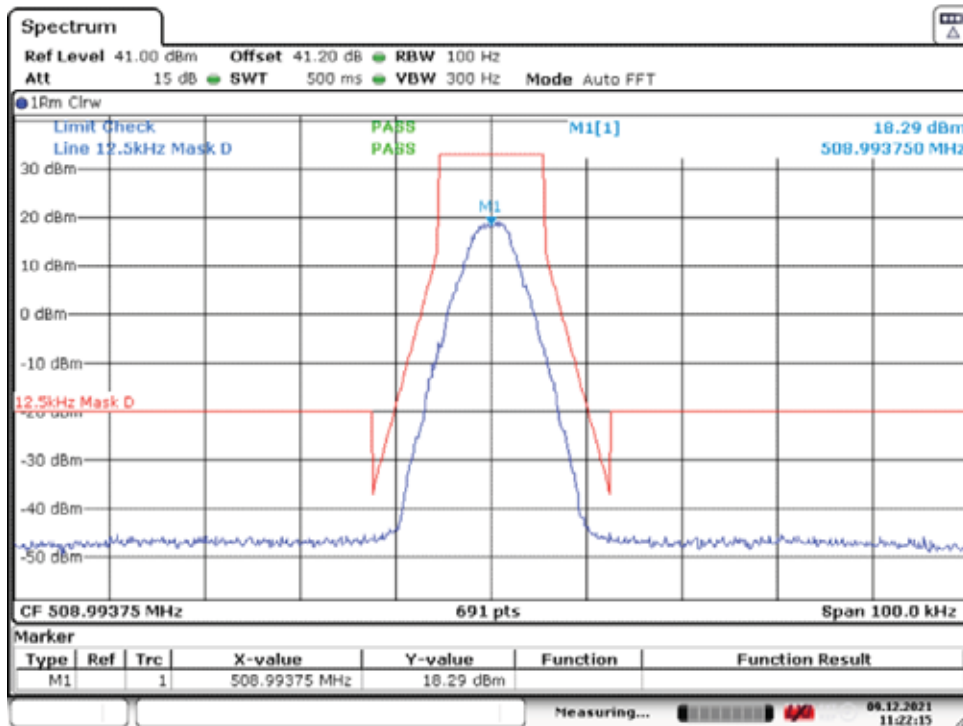

Date: 9. DEC. 2021 11:22:14

With the input signal amplitude set the AGC threshold
 High Frequency: 508.99375MHz

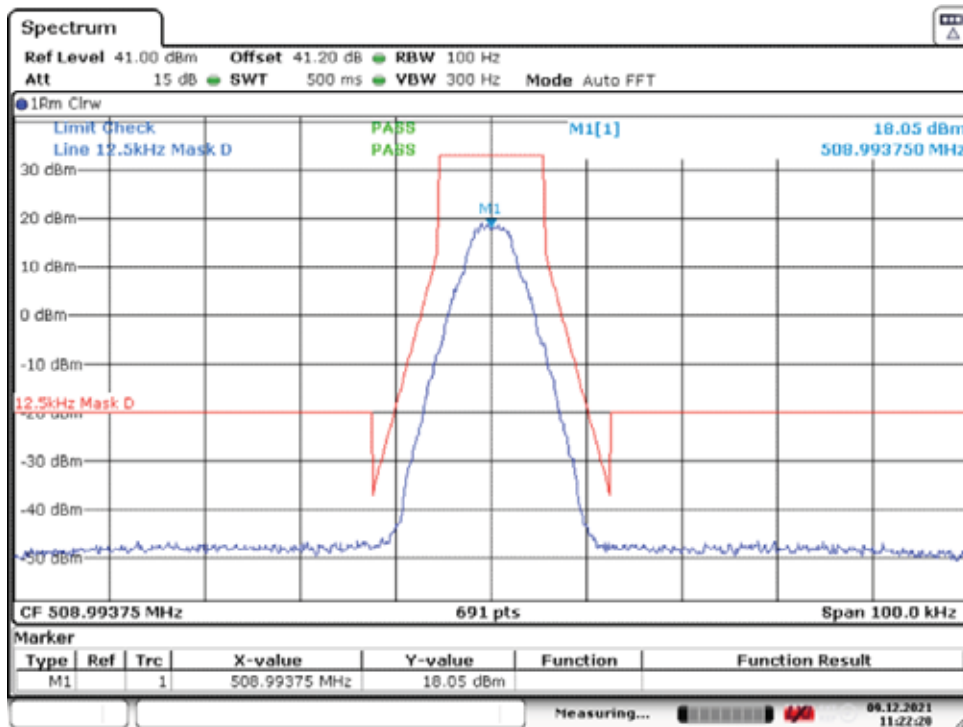

Date: 9. DEC. 2021 11:22:20

With the input signal amplitude set 3 dB above the AGC threshold
 High Frequency: 508.99375MHz

10.5.5.1.1.1.2. P25 Phase II(H-DQPSK) mode

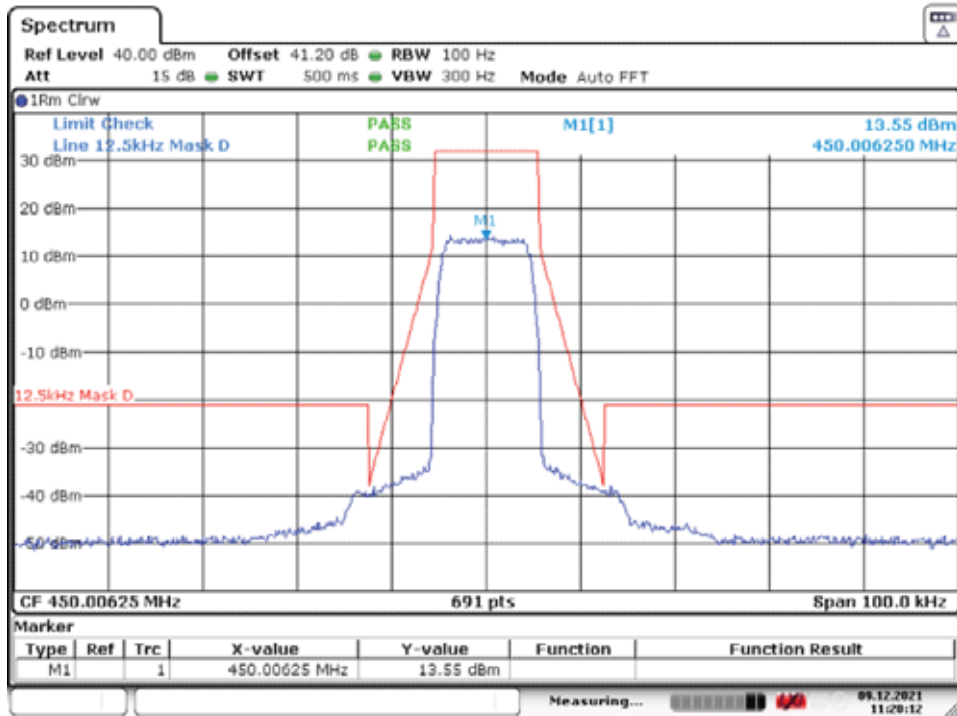

Date: 9.DEC.2021 11:20:12

With the input signal amplitude set the AGC threshold
Low Frequency: 450.00625MHz

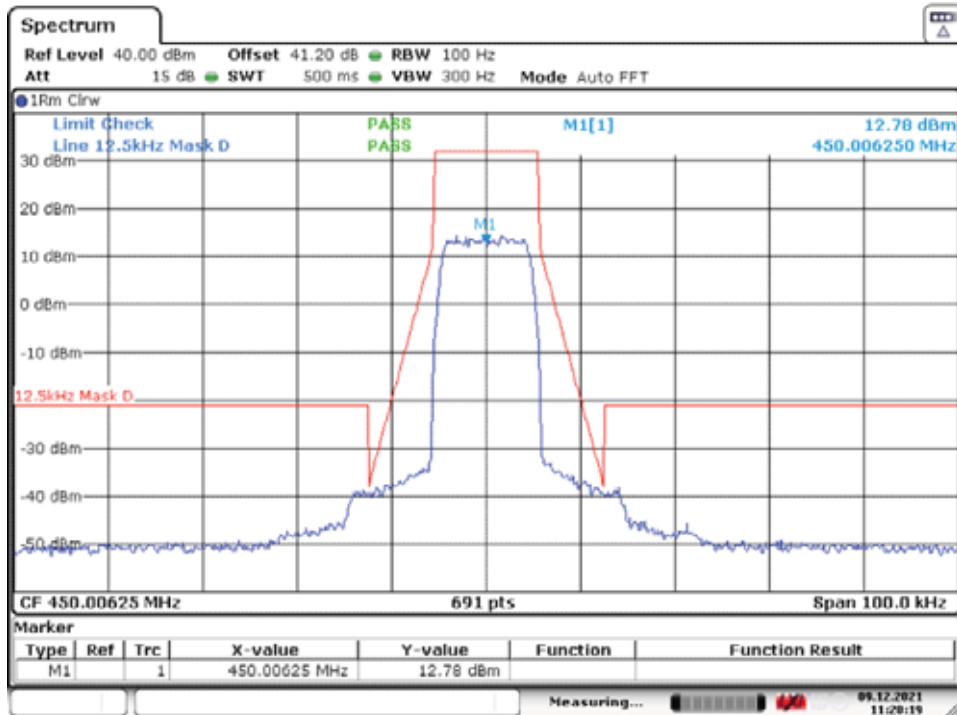

Date: 9.DEC.2021 11:20:19

With the input signal amplitude set 3 dB above the AGC threshold
Low Frequency: 450.00625MHz

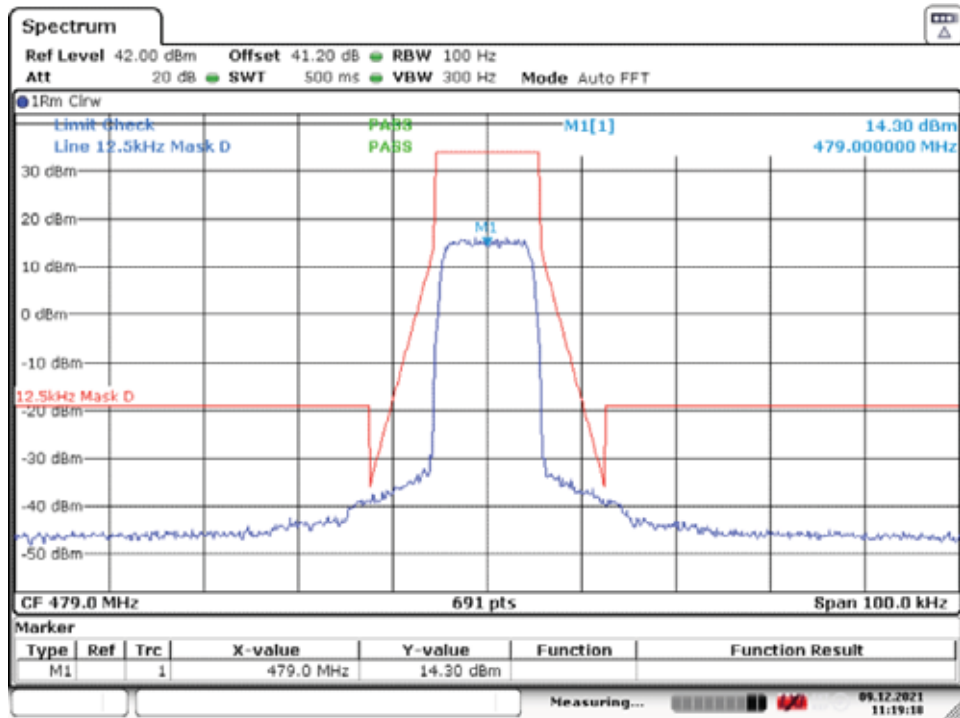

Date: 9.DEC.2021 11:19:18

With the input signal amplitude set the AGC threshold
 Middle Frequency: 479.0MHz

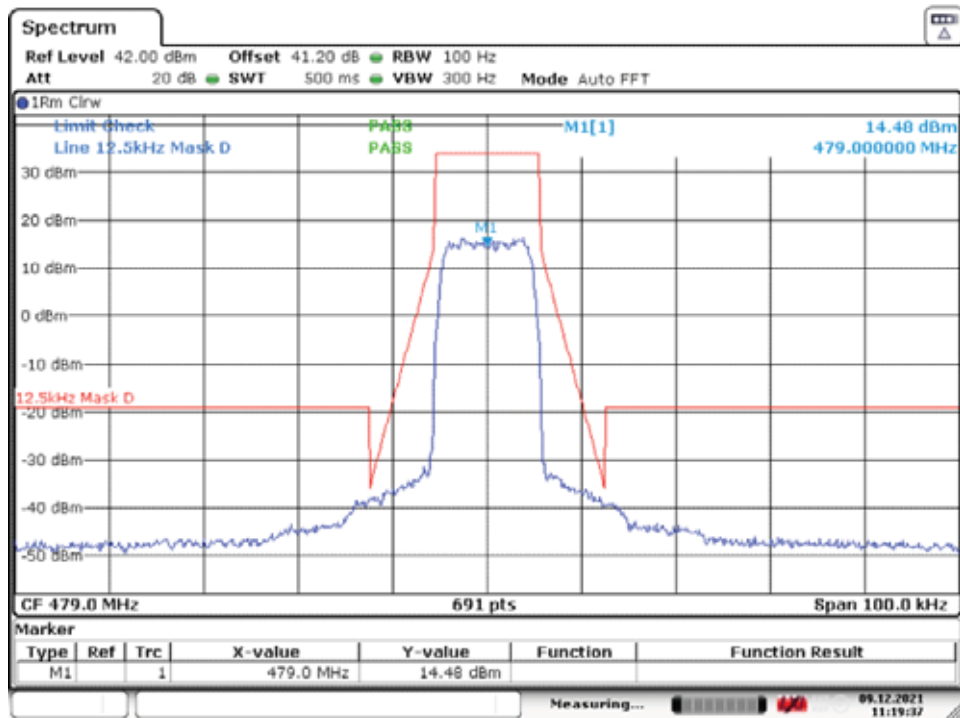

Date: 9.DEC.2021 11:19:38

With the input signal amplitude set 3 dB above the AGC threshold
 Middle Frequency: 479.0MHz

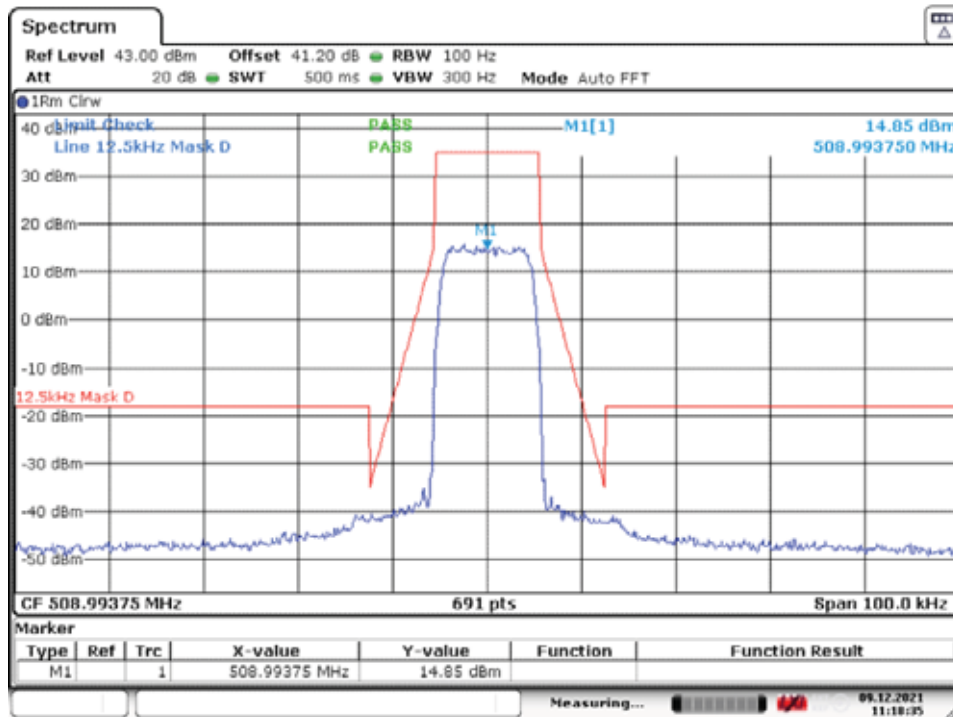

Date: 9.DEC.2021 11:18:36

With the input signal amplitude set the AGC threshold
 High Frequency: 508.99375MHz

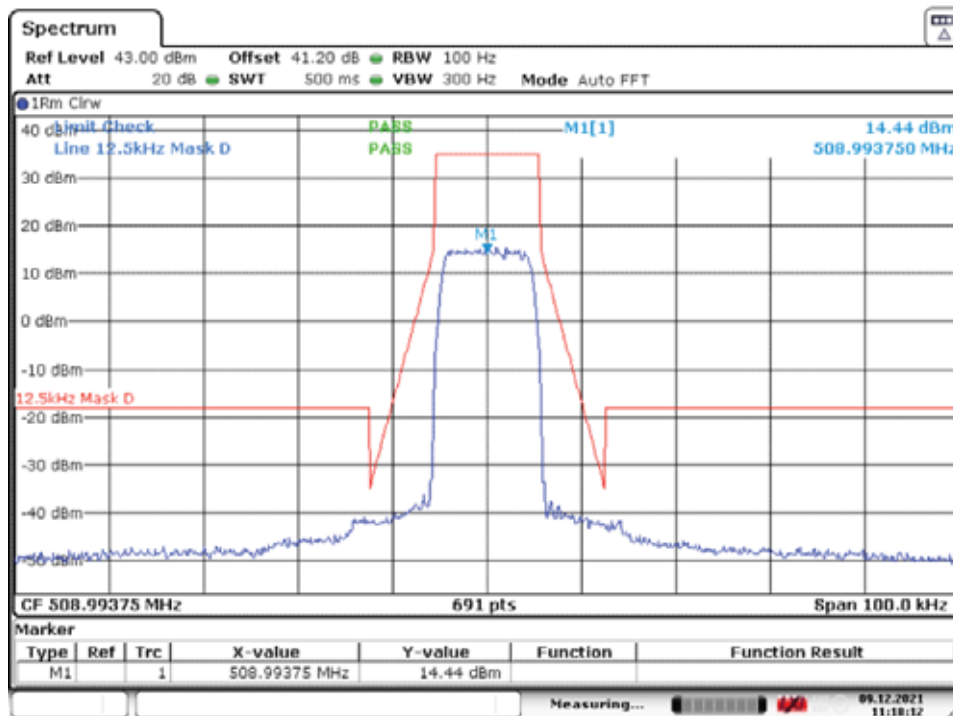

Date: 9.DEC.2021 11:18:12

With the input signal amplitude set 3 dB above the AGC threshold
 High Frequency: 508.99375MHz

10.5.5.1.1.1.3. 6.25kHz Analog FM mode

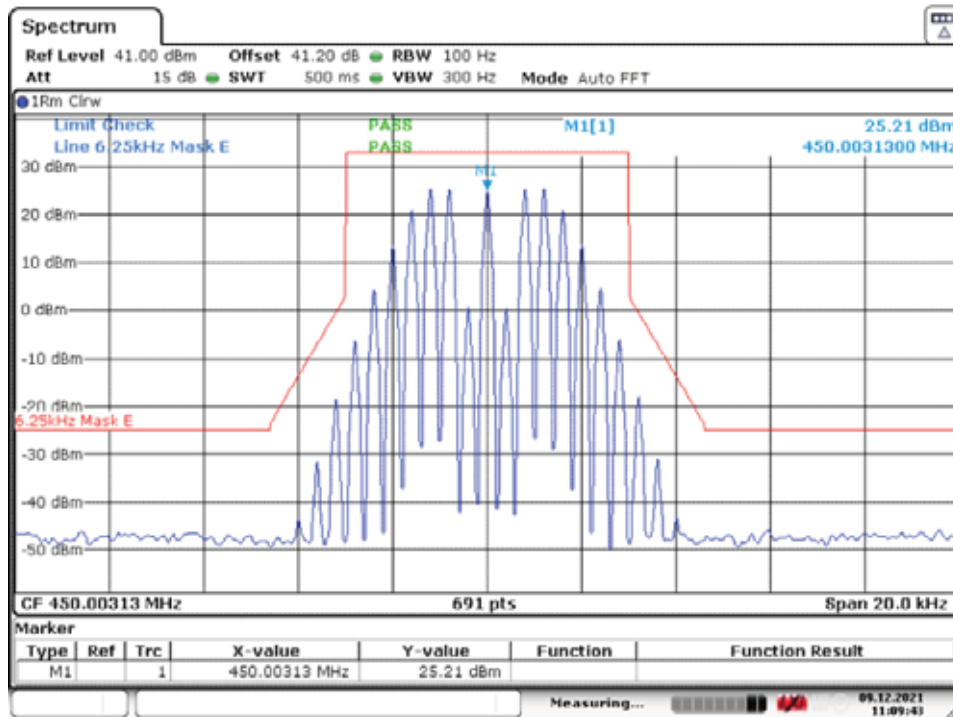

Date: 9.DEC.2021 11:09:43

With the input signal amplitude set the AGC threshold
 Low Frequency: 450.00313MHz

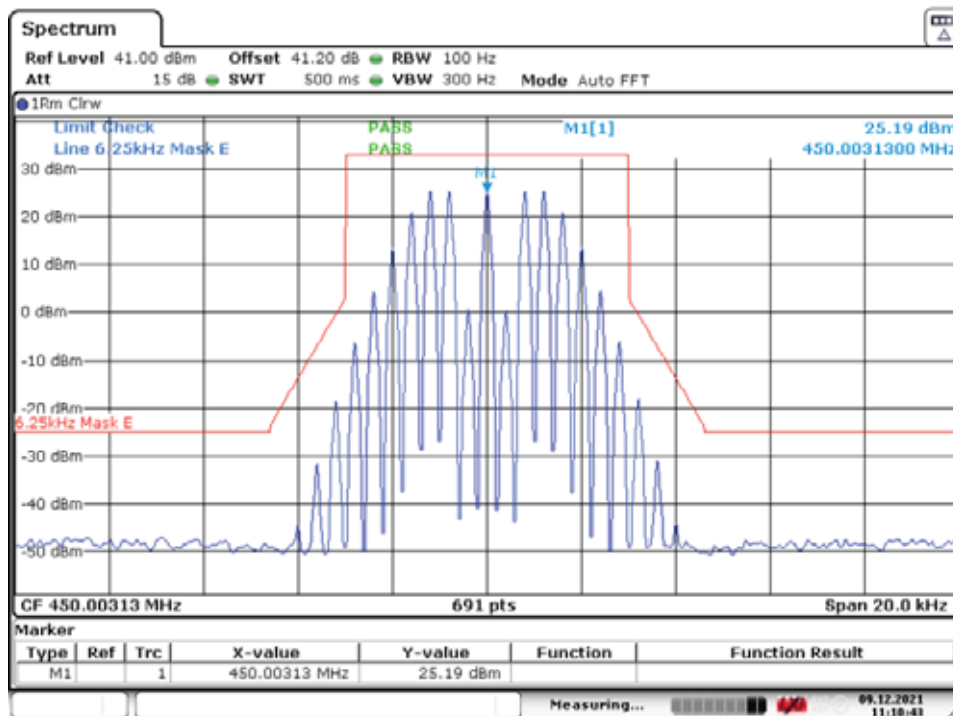

Date: 9.DEC.2021 11:10:43

With the input signal amplitude set 3 dB above the AGC threshold
 Low Frequency: 450.00313MHz

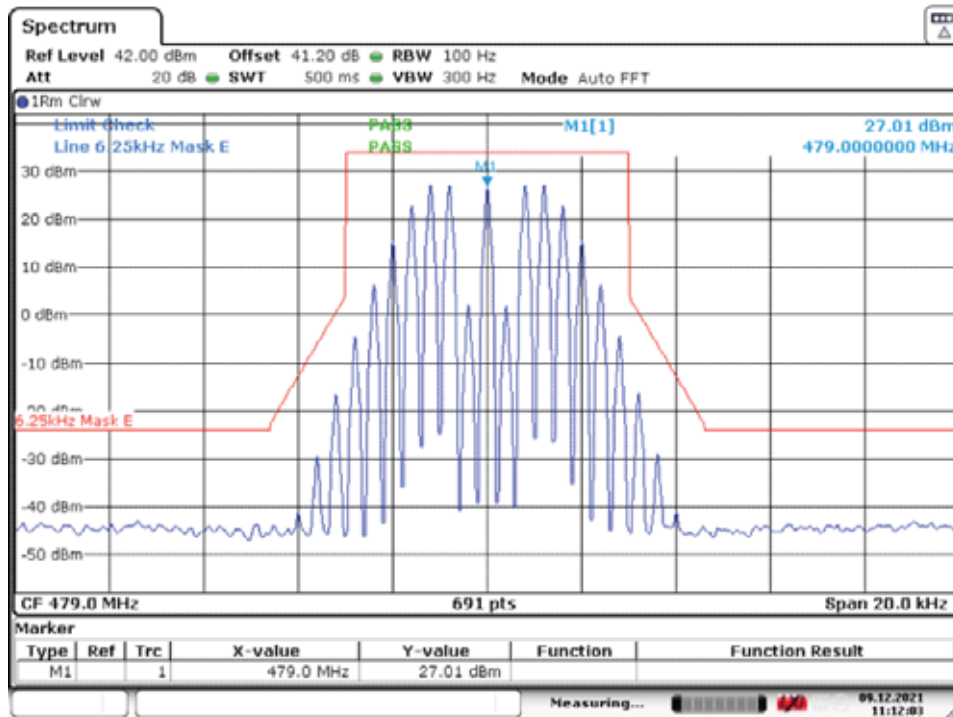

Date: 9.DEC.2021 11:12:03

With the input signal amplitude set the AGC threshold
 Middle Frequency: 479.0MHz

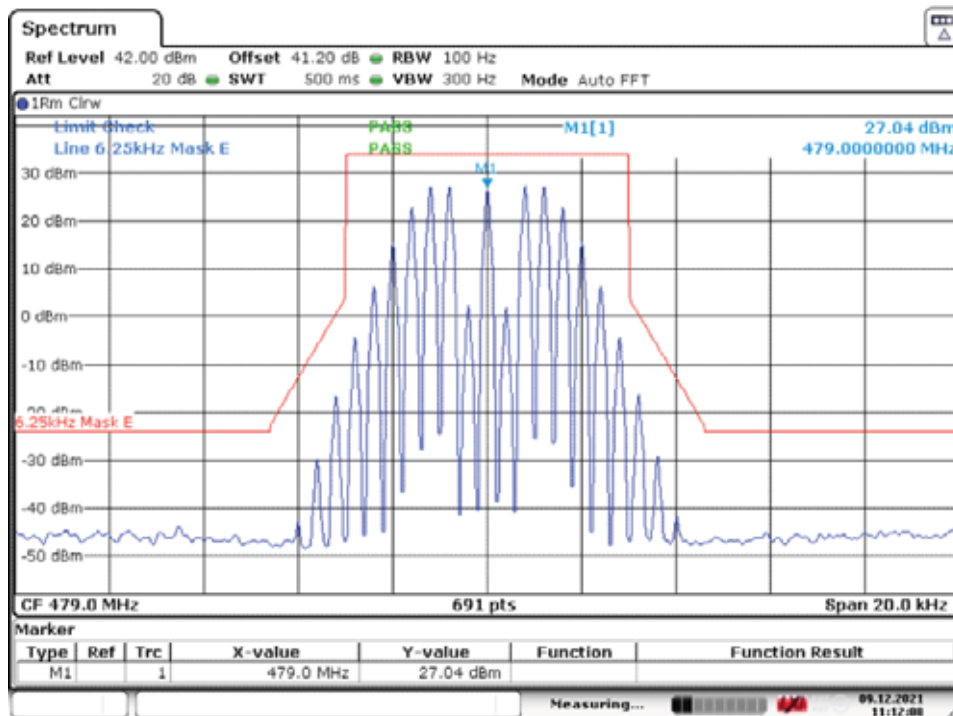

Date: 9.DEC.2021 11:12:08

With the input signal amplitude set 3 dB above the AGC threshold
 Middle Frequency: 479.0MHz

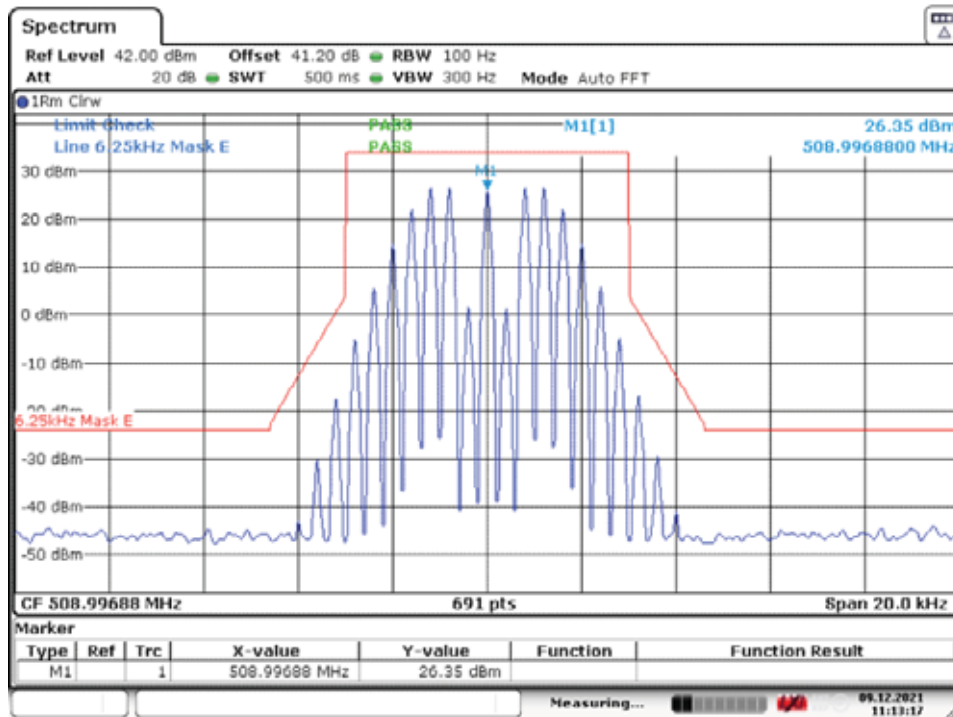

Date: 9.DEC.2021 11:13:18

With the input signal amplitude set the AGC threshold
 High Frequency: 508.99688MHz

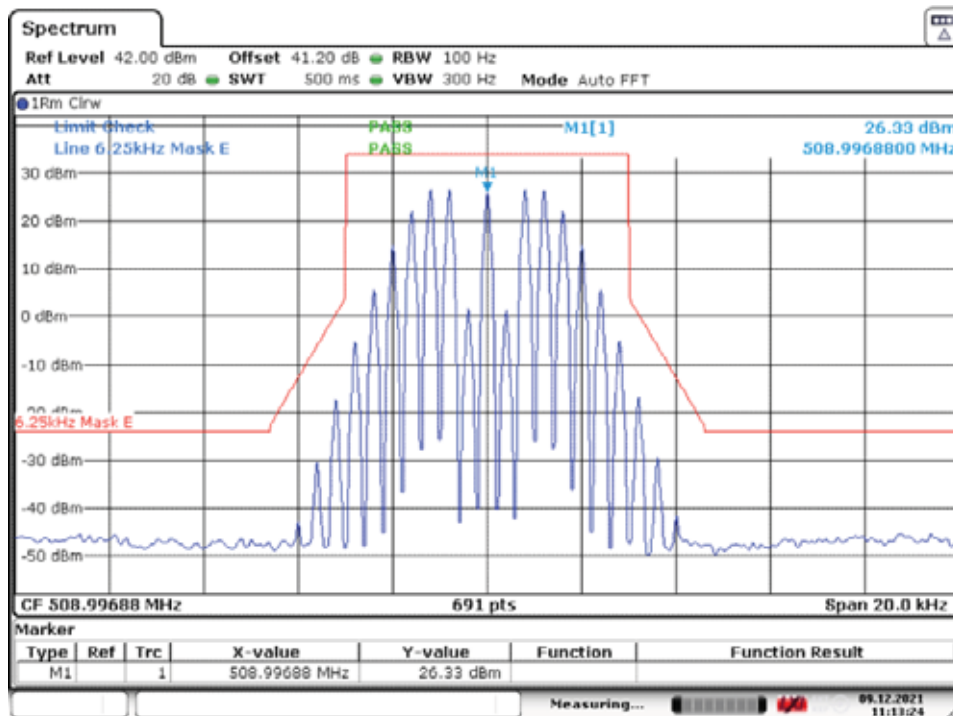

Date: 9.DEC.2021 11:13:25

With the input signal amplitude set 3 dB above the AGC threshold
 High Frequency: 508.99688MHz

10.5.5.1.1.4. 12.5kHz Analog FM mode

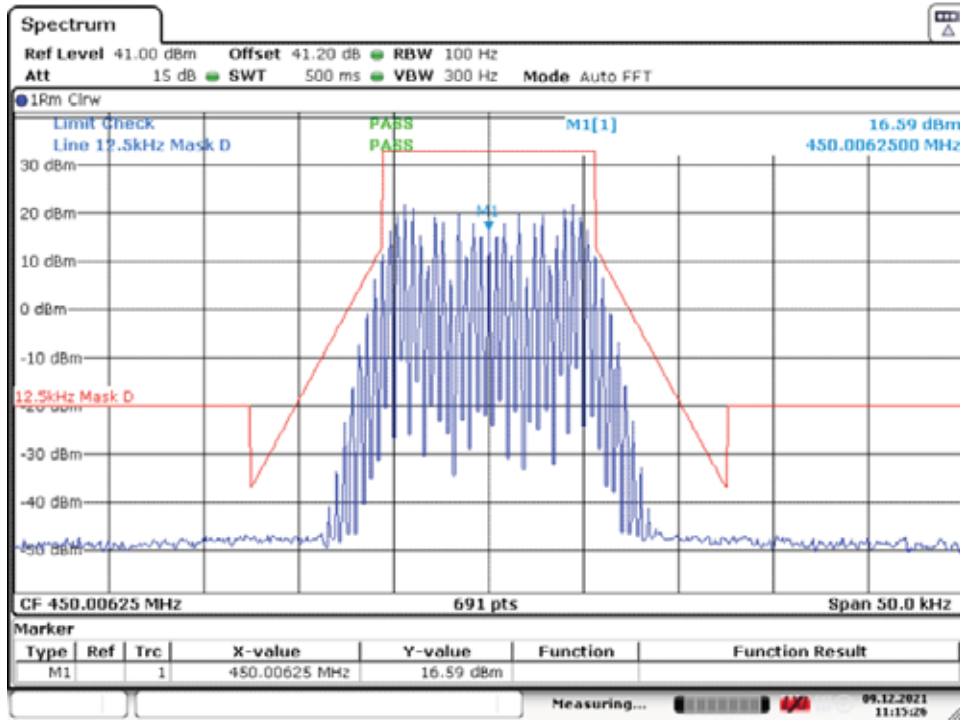

Date: 9 DEC 2021 11:15:28

With the input signal amplitude set the AGC threshold
 Low Frequency: 450.00625MHz

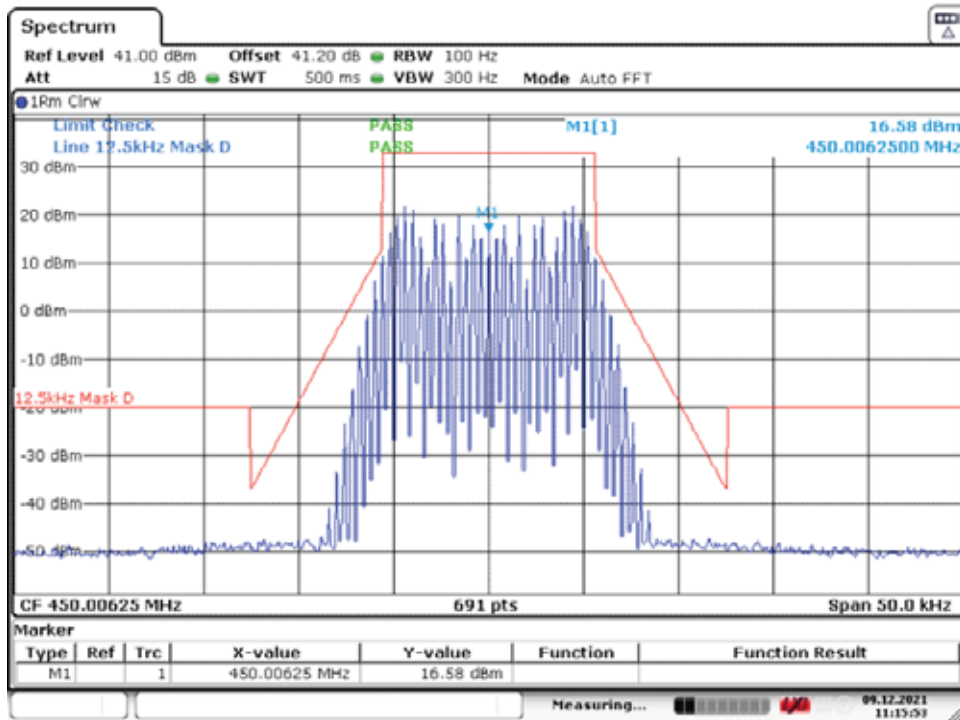

Date: 9 DEC 2021 11:15:54

With the input signal amplitude set 3 dB above the AGC threshold
 Low Frequency: 450.00625MHz

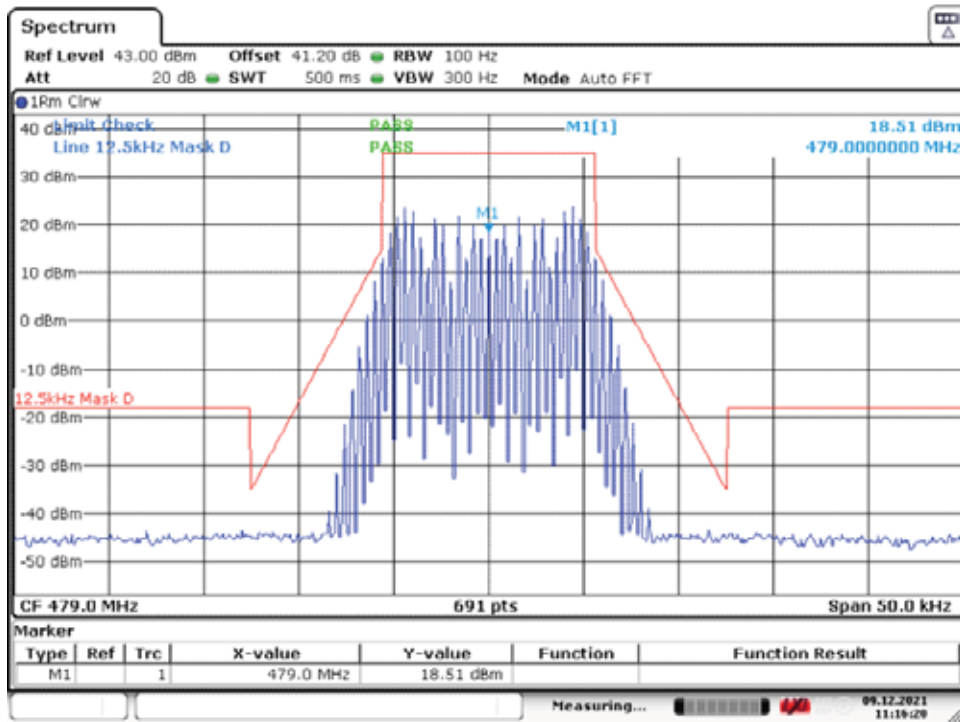

Date: 9 DEC 2021 11:16:20

With the input signal amplitude set the AGC threshold
 Middle Frequency: 479.0MHz

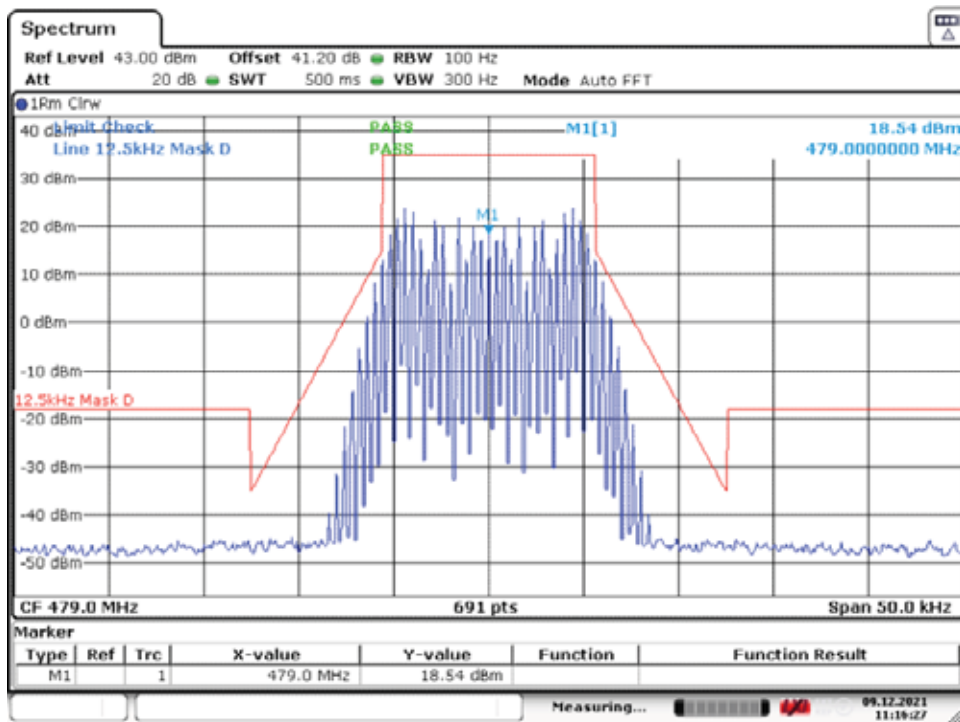

Date: 9 DEC 2021 11:16:27

With the input signal amplitude set 3 dB above the AGC threshold
 Middle Frequency: 479.0MHz

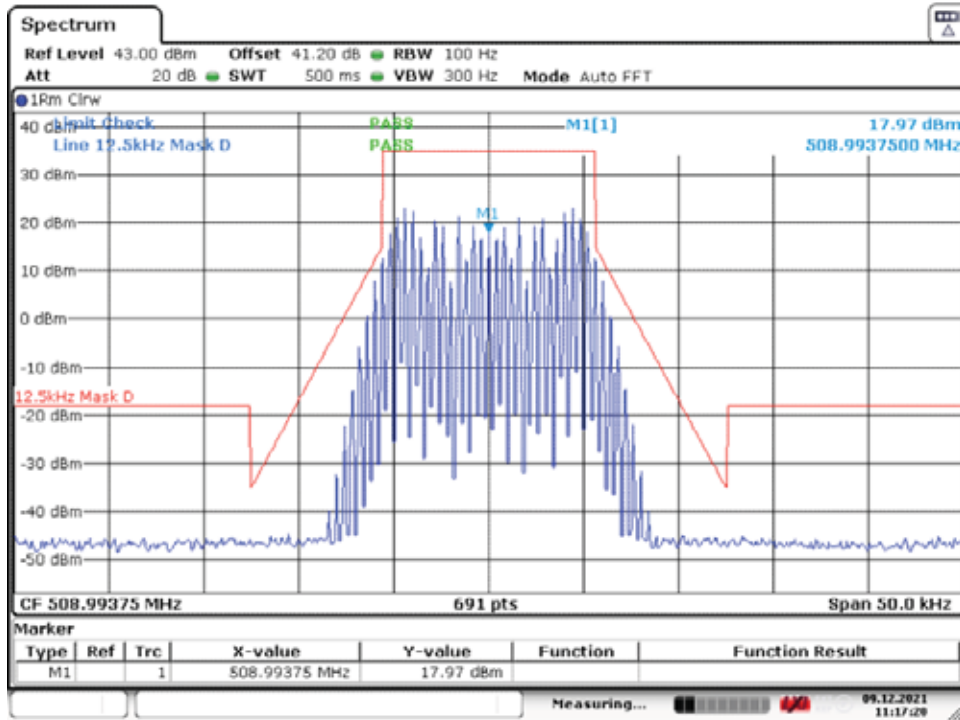

Date: 9 DEC 2021 11:17:21

With the input signal amplitude set the AGC threshold
High Frequency: 508.99375MHz

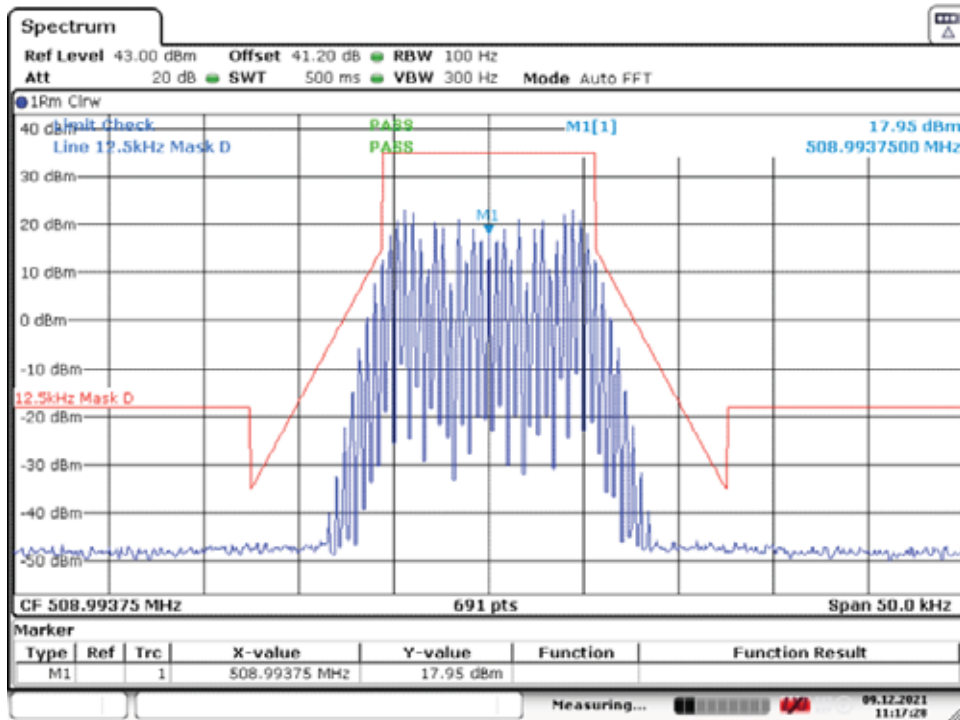

Date: 9 DEC 2021 11:17:28

With the input signal amplitude set 3 dB above the AGC threshold
High Frequency: 508.99375MHz

10.5.5.1.1.1.5. 25kHz Analog FM mode

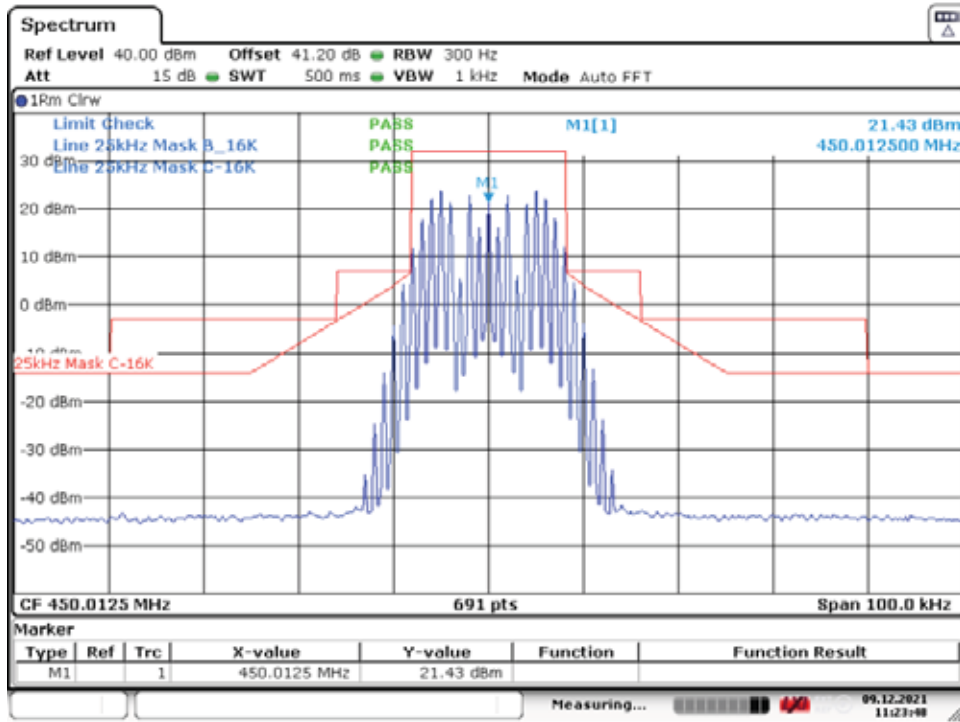

Date: 9 DEC. 2021 11:23:48

With the input signal amplitude set the AGC threshold
 Low Frequency: 450.0125MHz

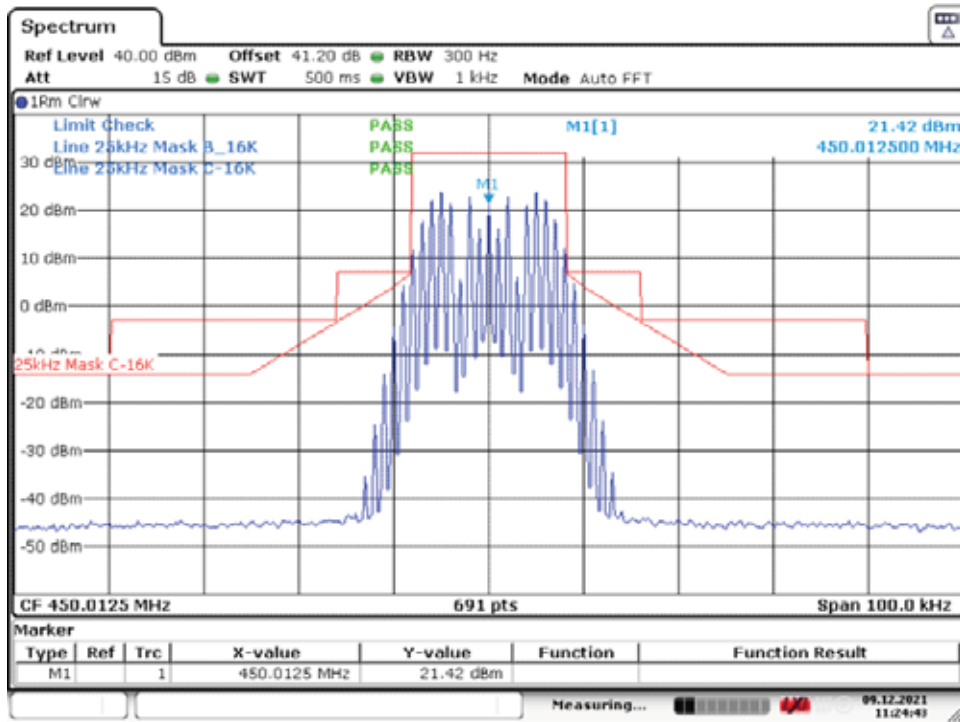

Date: 9 DEC. 2021 11:24:42

With the input signal amplitude set 3 dB above the AGC threshold
 Low Frequency: 450.0125MHz

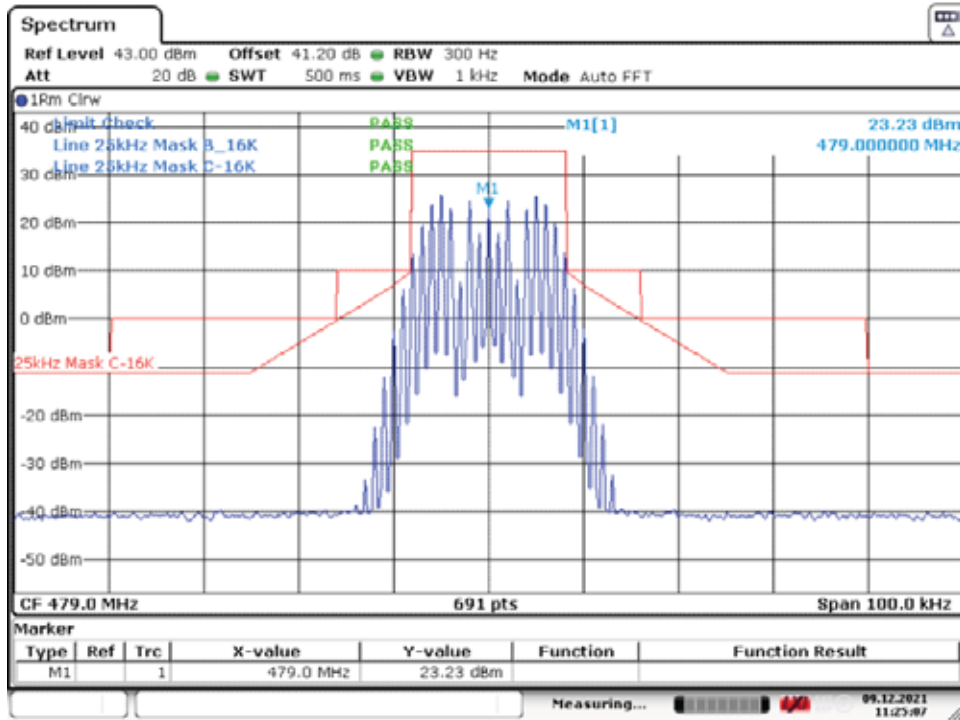

Date: 9 DEC 2021 11:25:07

With the input signal amplitude set the AGC threshold
 Middle Frequency: 479.0MHz

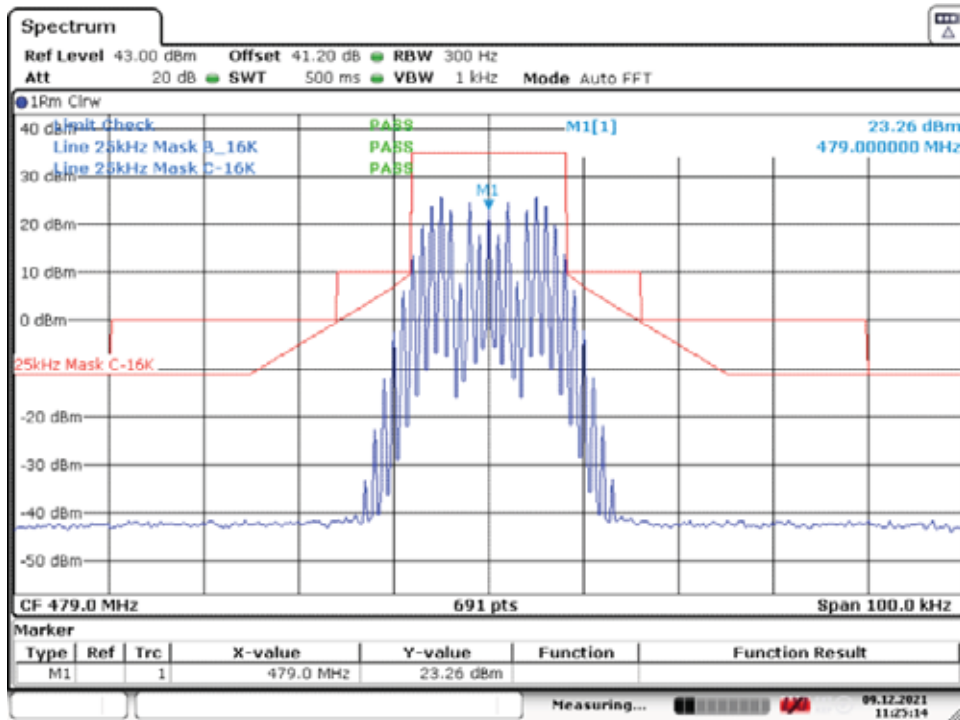

Date: 9 DEC 2021 11:25:14

With the input signal amplitude set 3 dB above the AGC threshold
 Middle Frequency: 479.0MHz

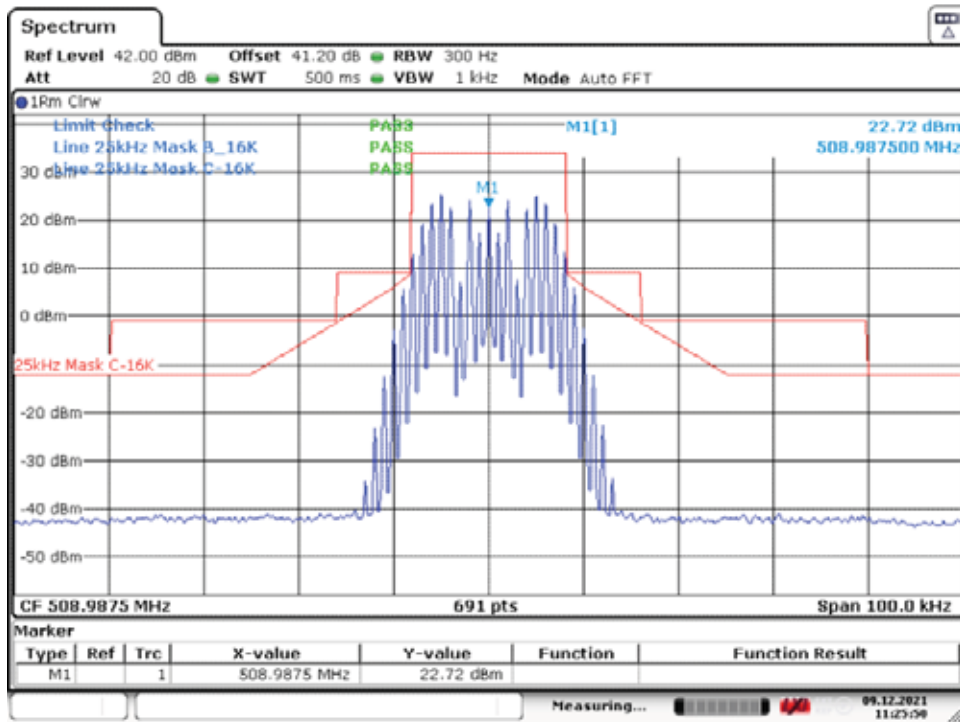

Date: 9 DEC 2021 11:25:51

With the input signal amplitude set the AGC threshold
 High Frequency: 508.9875MHz

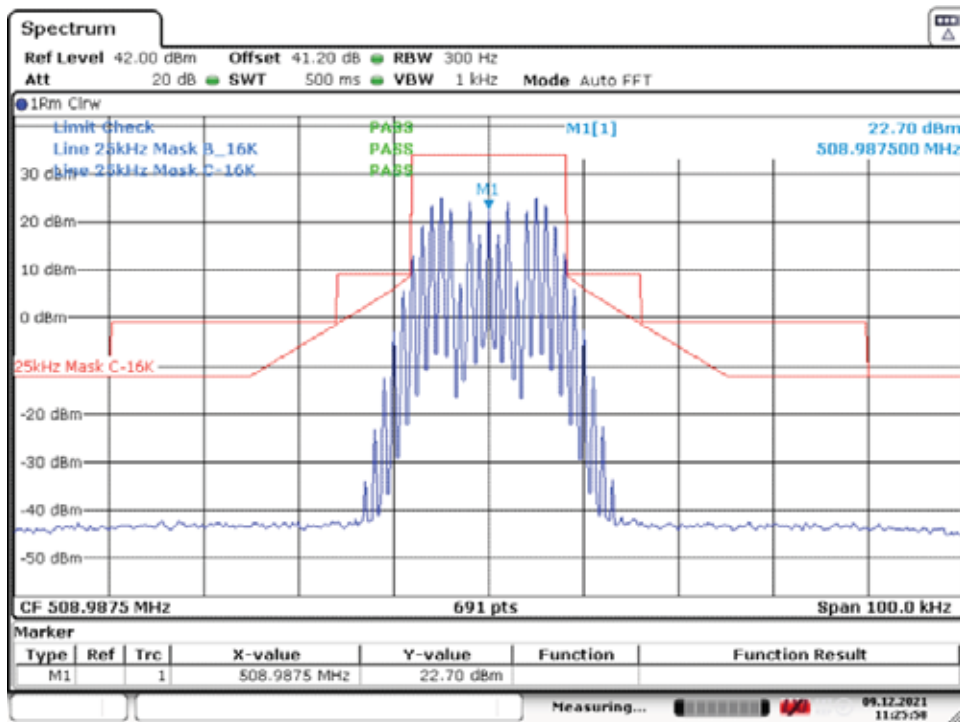

Date: 9 DEC 2021 11:25:58

With the input signal amplitude set 3 dB above the AGC threshold
 High Frequency: 508.9875MHz

10.5.5.1.1.2. Uplink

10.5.5.1.1.2.1. P25 Phase I(C4FM) mode

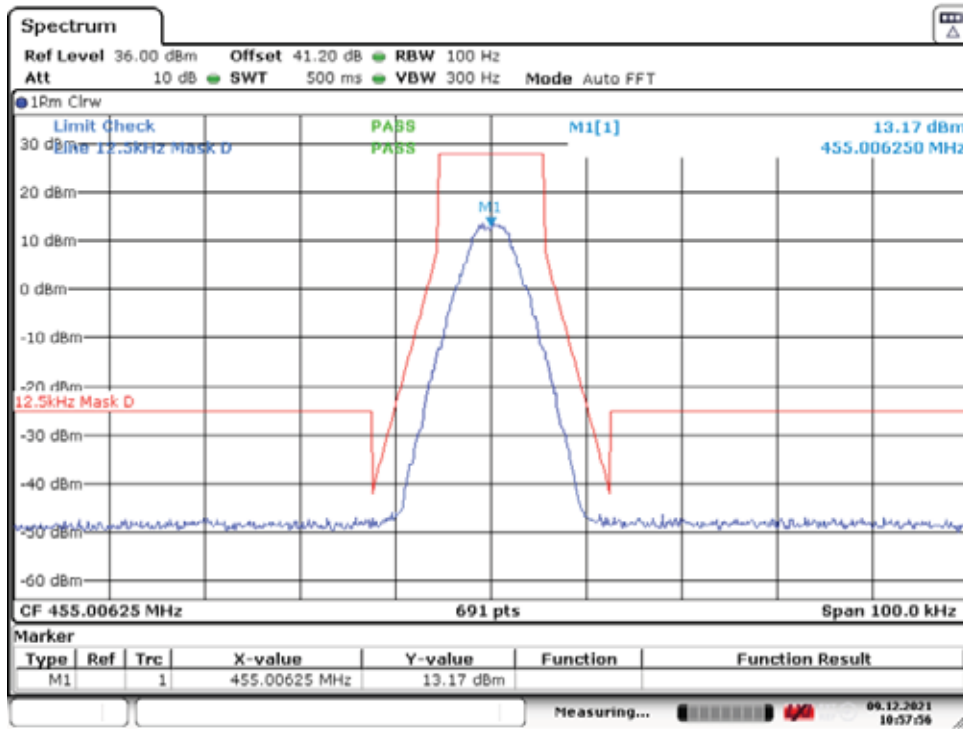

Date: 9 DEC 2021 10:57:57

With the input signal amplitude set the AGC threshold
Low Frequency: 455.00625MHz

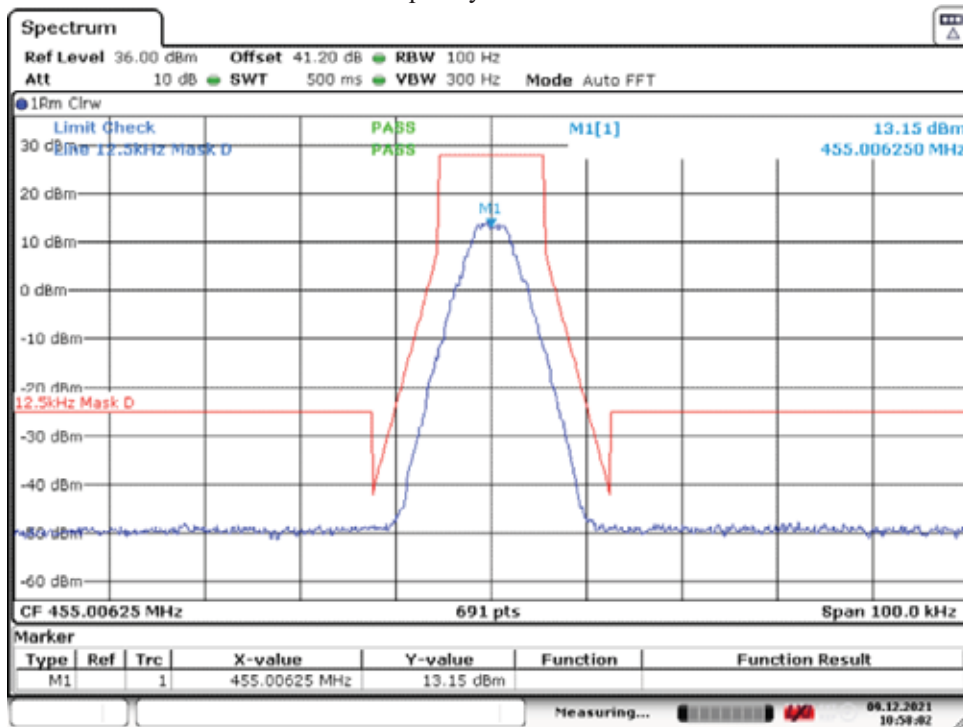

Date: 9 DEC 2021 10:58:03

With the input signal amplitude set 3 dB above the AGC threshold
Low Frequency: 455.00625MHz

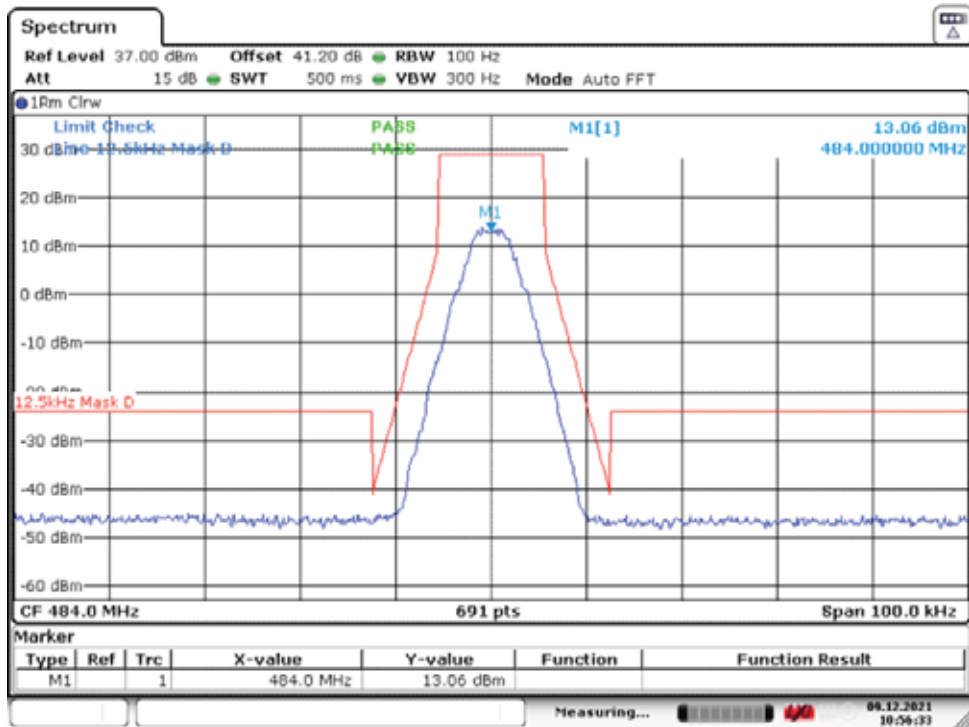

Date: 9.DEC.2021 10:56:34

With the input signal amplitude set the AGC threshold
 Middle Frequency: 484.0MHz

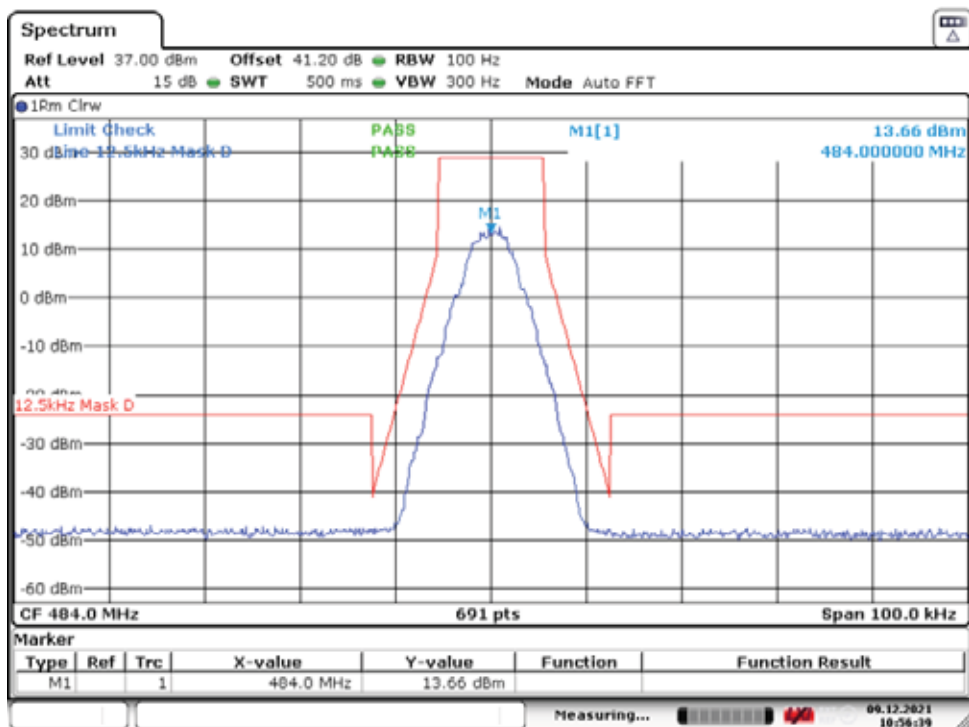

Date: 9.DEC.2021 10:56:40

With the input signal amplitude set 3 dB above the AGC threshold
 Middle Frequency: 484.0MHz

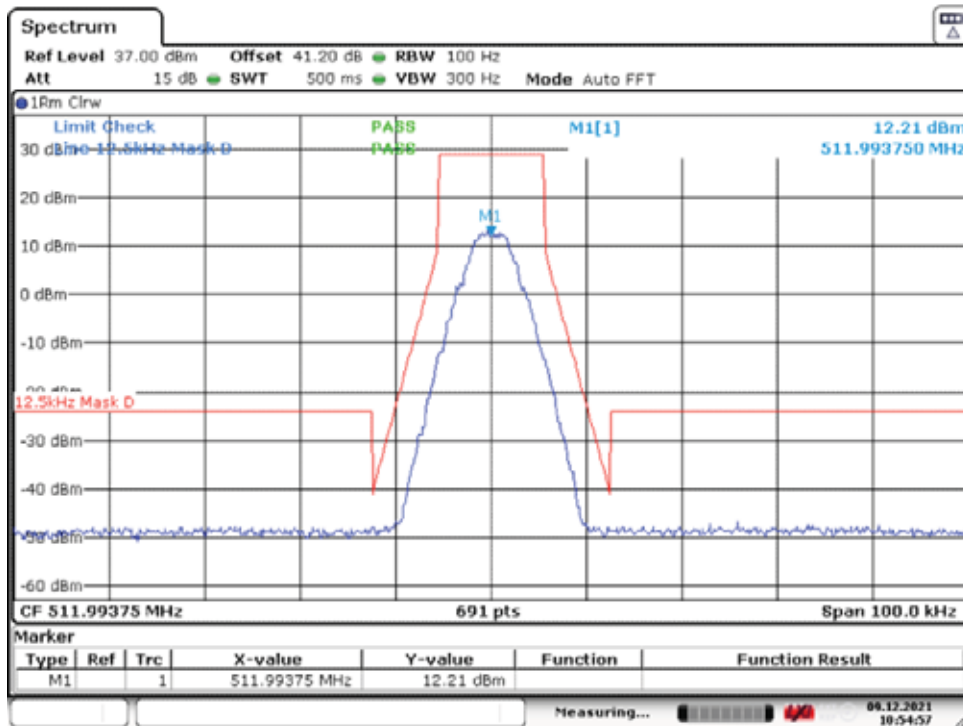

Date: 9 DEC 2021 10:54:58

With the input signal amplitude set the AGC threshold
 High Frequency: 511.99375MHz

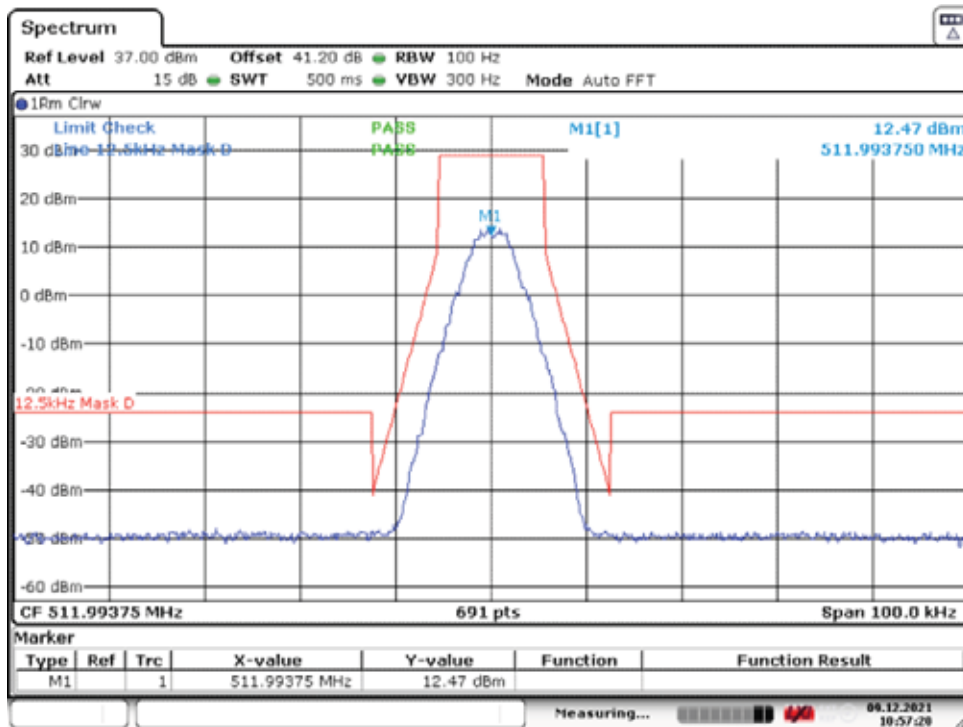

Date: 9 DEC 2021 10:57:21

With the input signal amplitude set 3 dB above the AGC threshold
 High Frequency: 511.99375MHz

10.5.5.1.1.2.2. P25 Phase II(H-DQPSK) mode

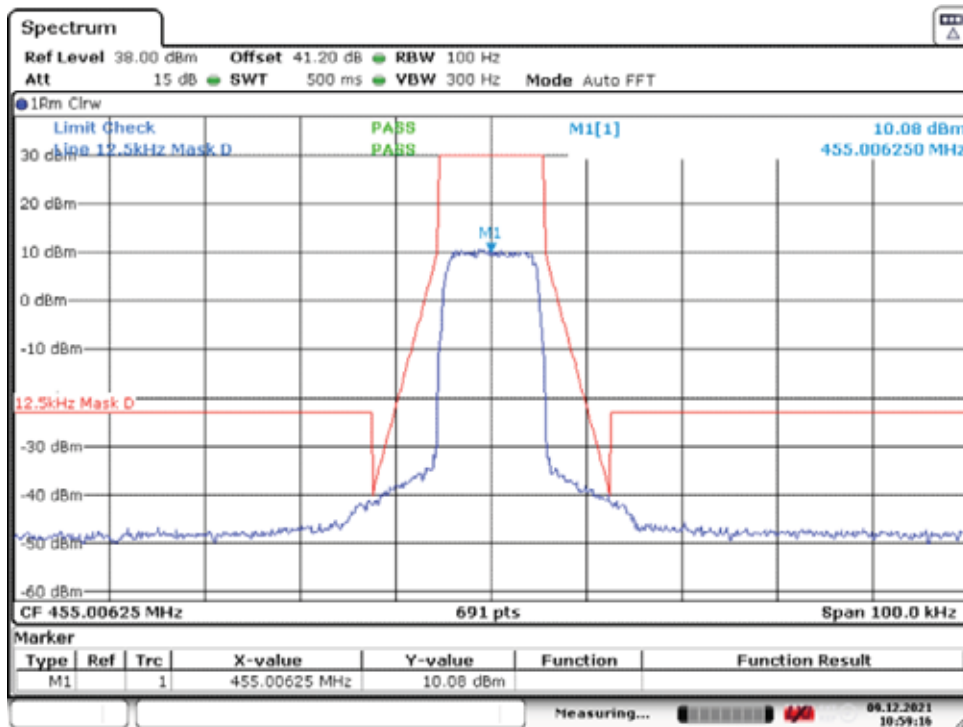

Date: 9.DEC.2021 10:59:17

With the input signal amplitude set the AGC threshold
 Low Frequency: 455.00625MHz

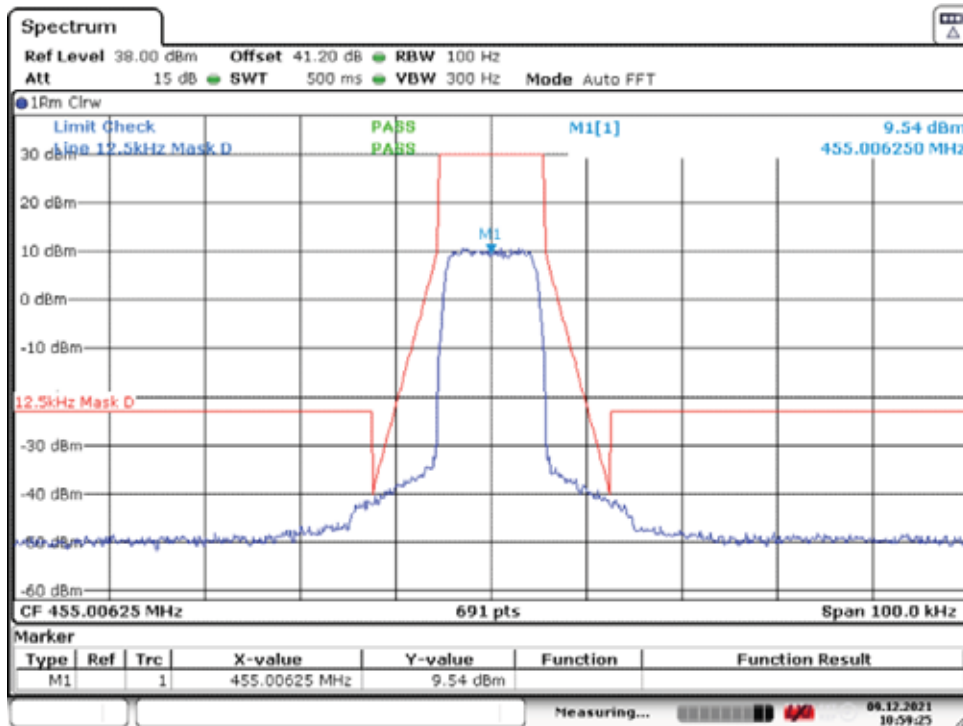

Date: 9.DEC.2021 10:59:25

With the input signal amplitude set 3 dB above the AGC threshold
 Low Frequency: 455.00625MHz

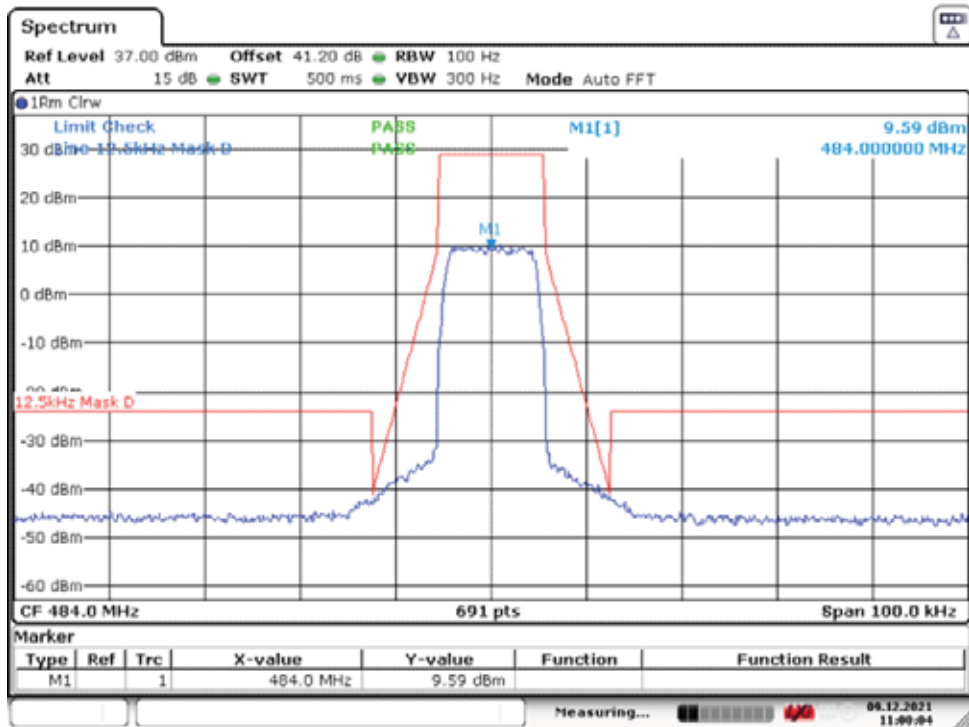

Date: 9.DEC.2021 11:00:04

With the input signal amplitude set the AGC threshold
 Middle Frequency: 484.0MHz

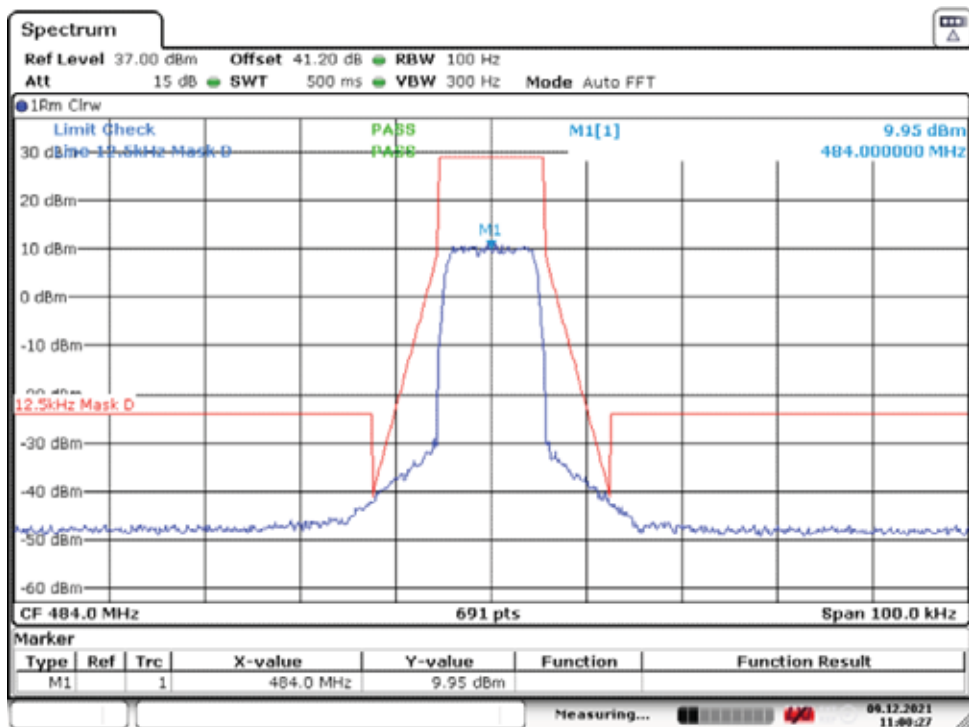

Date: 9.DEC.2021 11:00:28

With the input signal amplitude set 3 dB above the AGC threshold
 Middle Frequency: 484.0MHz

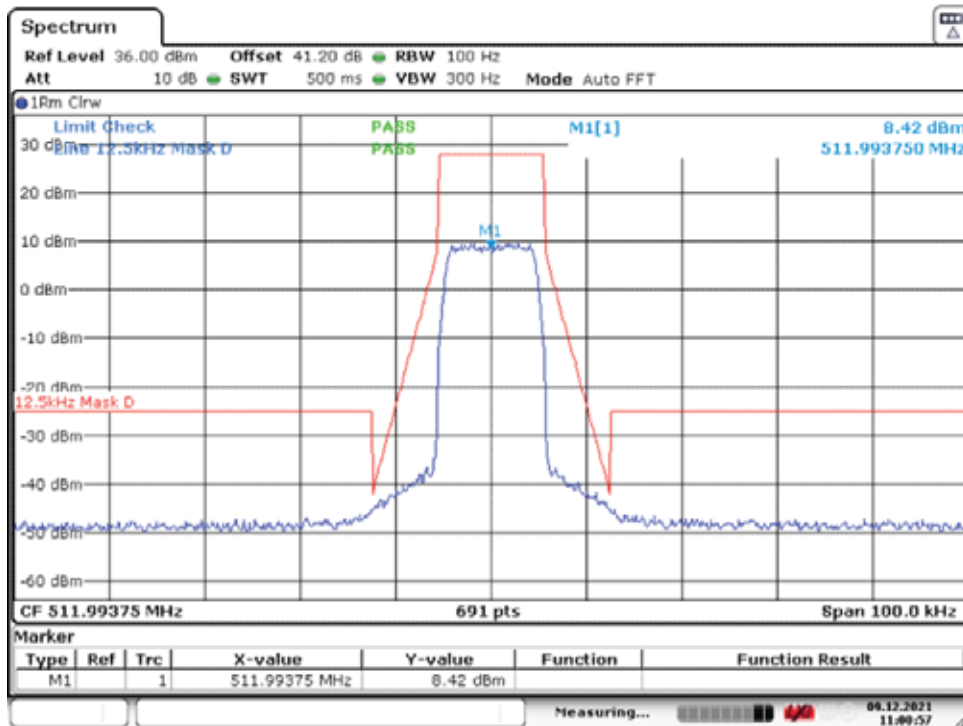

Date: 9.DEC.2021 11:00:57

With the input signal amplitude set the AGC threshold
 High Frequency: 511.99375MHz

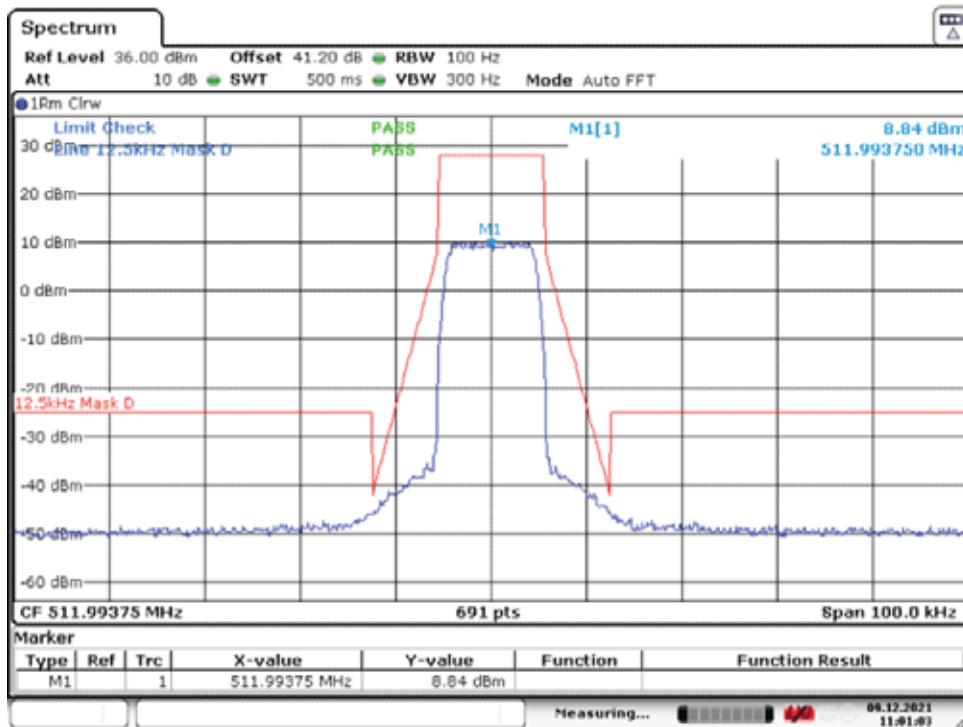

Date: 9.DEC.2021 11:01:04

With the input signal amplitude set 3 dB above the AGC threshold
 High Frequency: 511.99375MHz

10.5.5.1.1.2.3. 6.25kHz Analog FM mode

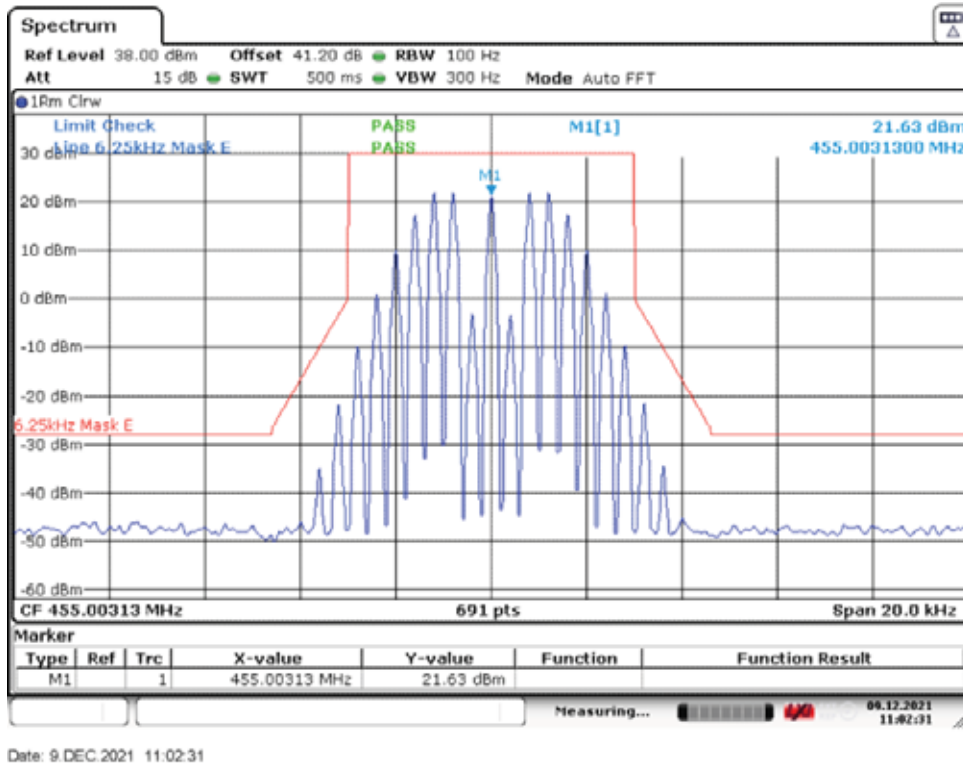

With the input signal amplitude set the AGC threshold
 Low Frequency: 455.00313MHz

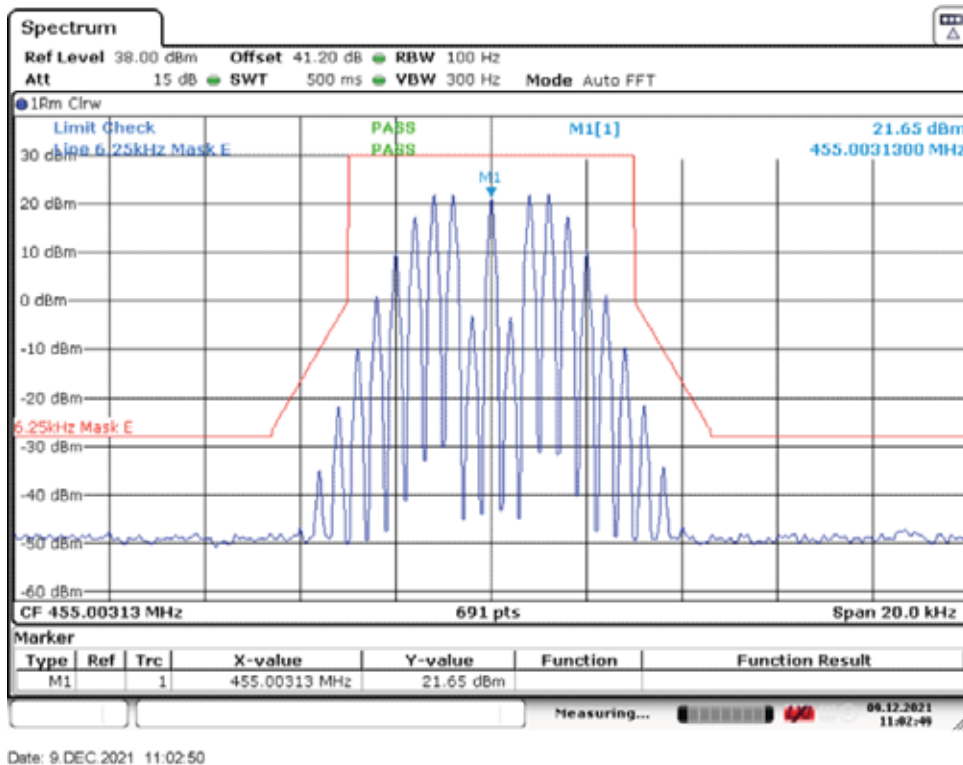

With the input signal amplitude set 3 dB above the AGC threshold
 Low Frequency: 455.00313MHz

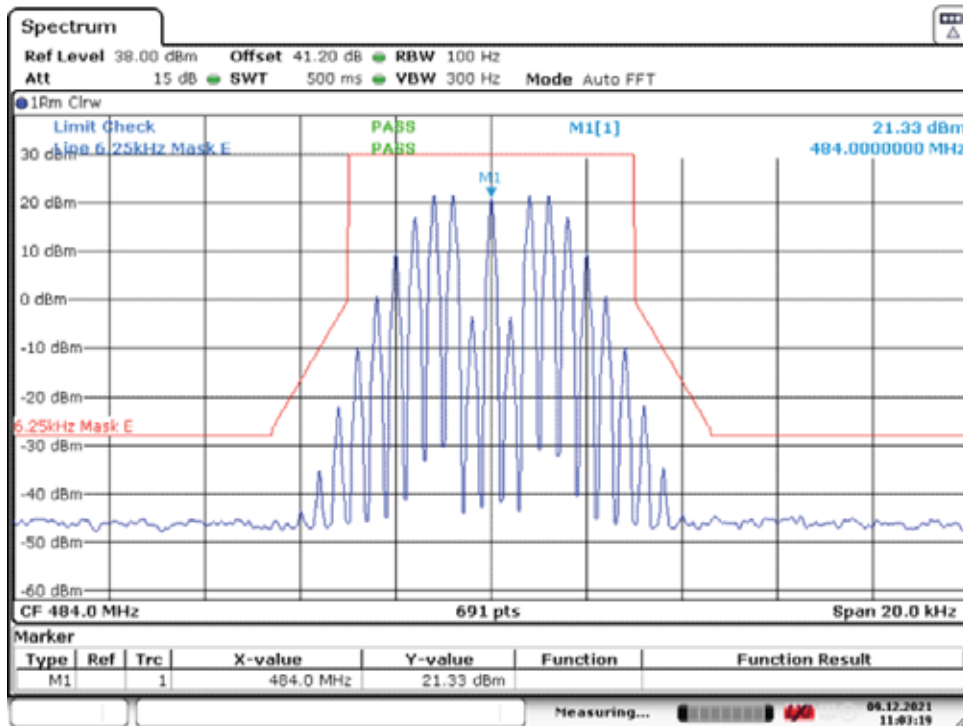

Date: 9.DEC.2021 11:03:19

With the input signal amplitude set the AGC threshold
 Middle Frequency: 484.0MHz

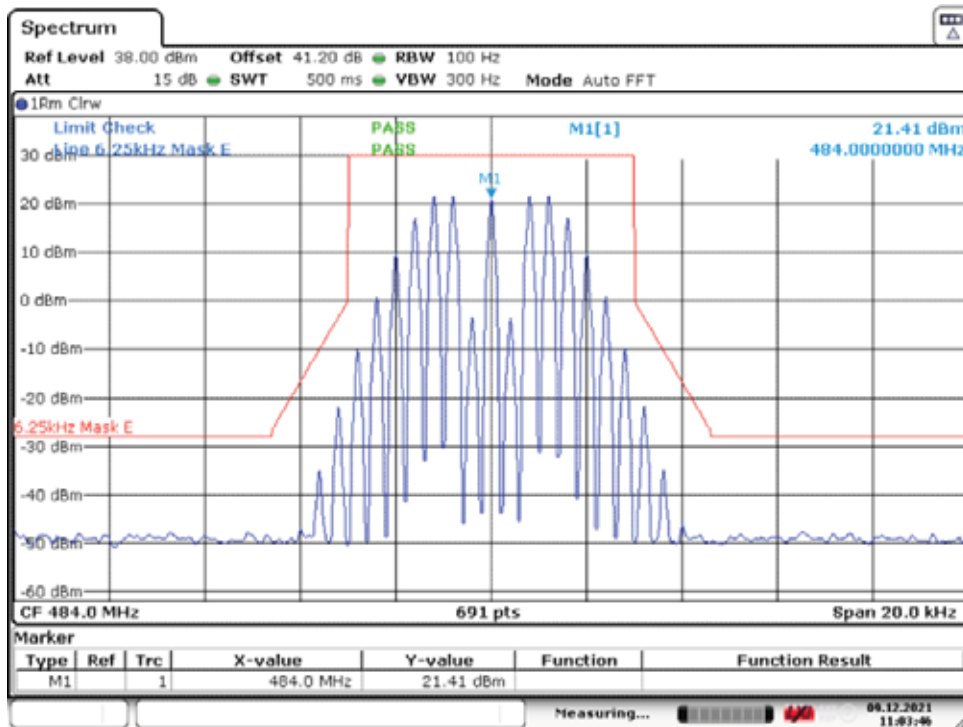

Date: 9.DEC.2021 11:03:47

With the input signal amplitude set 3 dB above the AGC threshold
 Middle Frequency: 484.0MHz

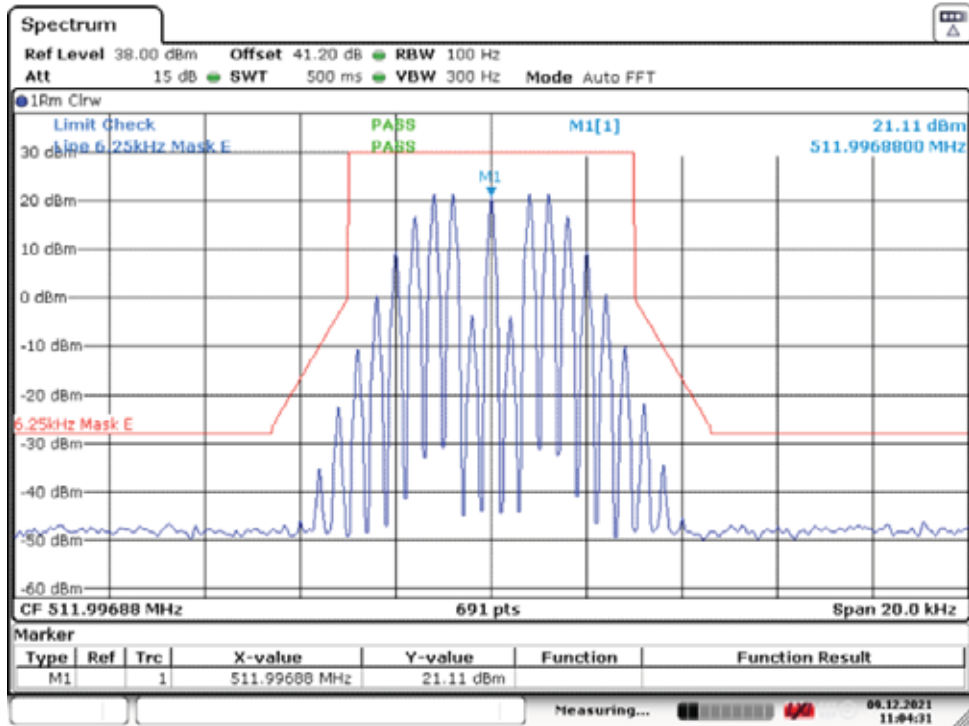

Date: 9.DEC.2021 11:04:31

With the input signal amplitude set the AGC threshold
 High Frequency: 511.99688MHz

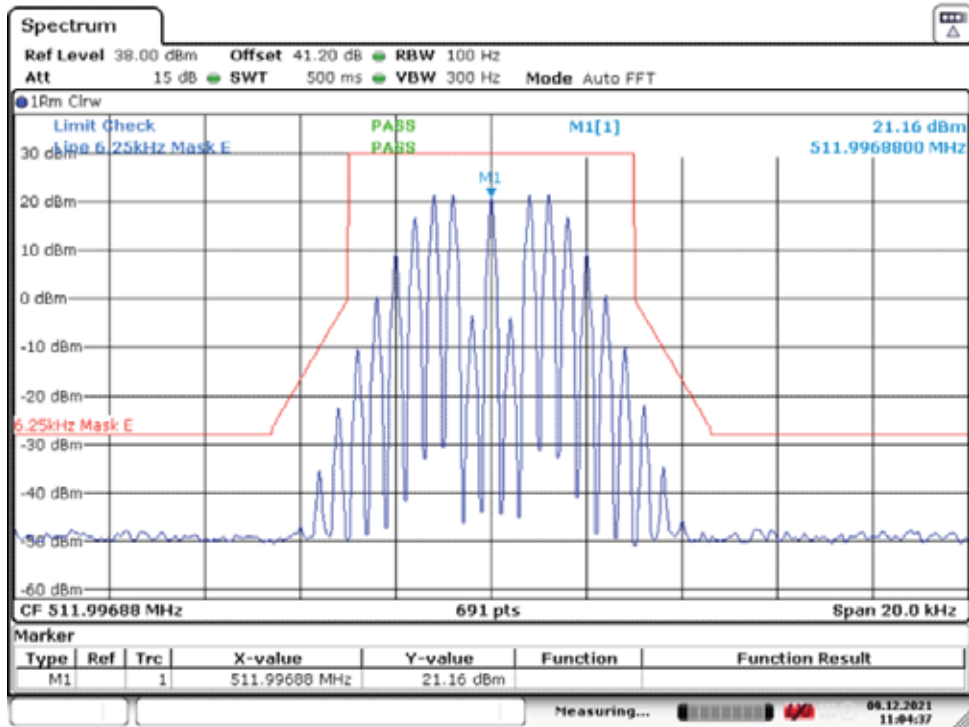

Date: 9.DEC.2021 11:04:37

With the input signal amplitude set 3 dB above the AGC threshold
 High Frequency: 511.99688MHz