



Test Report

Verified code:567186

Report No.: E20211115129001-1

Customer: Comba Telecom Network Systems Limited

Address: Flat/Rm 10, 3/F, Bio-Informatics Ctr, 2 Science Park West Avenue, HK Science Park, Pak Shek Kok, N.T. Hong Kong

Sample Name: Public Safety UHF DAS Master Unit

Sample Model: RX45V2F-A-48/ RX45V2F-A-AC

Receive Sample Date: 2021-11-22

Test Date: 2021-11-22 ~ 2021-12-15

Reference Document: FCC PART 2--- FREQUENCY ALLOCATIONS AND RADIO TREATY MATTERS;
GENERAL RULES AND REGULATIONS
FCC PART 90-- PRIVATE LAND MOBILE RADIO SERVICES

Test Result: Pass

FCC ID: PX8RX45V2F-A

Prepared By: *Yansha*

Reviewed By: *Zhao Zetian*

Approved By: *Xiao Liang*

GUANGZHOU GRG METROLOGY & TEST CO., LTD

Issued Date: 2021-01-20

GUANGZHOU GRG METROLOGY & TEST CO., LTD

Address: No.163 Pingyun Road, West of Huangpu Avenue, Guangzhou GuangdongChina (510656)

Tel: (+86) 400-602-0999 FAX: (+86) 020-38698685 Web: <http://www.grgtest.com>

Statement

1. The report is invalid without "special seal for inspection and testing"; some copies are invalid; The report is invalid if it is altered or missing; The report is invalid without the signature of the person who prepared, reviewed and approved it.
2. The sample information is provided by the client and responsible for its authenticity; The content of the report is only valid for the samples sent this time.
3. When there are reports in both Chinese and English, the Chinese version will prevail when the language problems are inconsistent.
4. If there is any objection concerning the report, please inform us within 15 days from the date of receiving the report.
5. Without the agreement of the laboratory, the client is not authorized to use the test results for unapproved propaganda.
6. The test report without CMA approval mark is only used for scientific research, teaching, internal quality control and other purposes.

TABLE OF CONTENTS

1. Applicant information	6
1.1. Client information	6
1.2. Manufacturer and Factory	6
2. General description of EUT	6
2.1. Basic description of EUT	6
2.2. Test signal modulation description.....	8
2.2.1. Analog signals	8
2.2.2. Digital signals.....	8
2.3. Signal Booster control process	9
2.3.1. System block	9
2.3.2. Signal control process	9
2.4. Description of Master Unit, Optical Expansion Unit, and Remote Unit connection port	10
3. Related documents	11
4. Test result summary	12
5. About Signal Booster	13
5.1. KDB 935210 D02 APPENDIX A3.1	13
5.2. FCC part 90.219 (a) Definitions.....	13
6. Test modes	14
7. Laboratory and Accreditations	15
7.1. Laboratory	15
7.2. Accreditations.....	15
8. Measurements uncertainty.....	16
9. Equipments used during test.....	17
10. Radio technical requirement specification	19
10.1. Test Frequencies.....	19
10.1.1. Requirements.....	19
10.1.2. Result.....	21
10.2. Input Signals.....	22
10.2.1. Requirements.....	22
10.2.2. Result.....	22
10.2.3. Input Signals screenshot.....	23
10.3. AGC Threshold	38
10.3.1. Requirements.....	38
10.3.2. Test configuration.....	38
10.3.3. Test procedures.....	39
10.3.4. Test results.....	40
10.4. Out-of-band rejection	43
10.4.1. Requirements.....	43
10.4.2. Test configuration.....	43
10.4.3. Test procedures.....	44

10.4.4.	Test results.....	45
10.4.5.	Test screenshot.....	46
10.5.	Input VS output Comparison.....	48
10.5.1.	Requirements.....	48
10.5.2.	Test configuration.....	53
10.5.3.	Test procedures.....	54
10.5.4.	Test results.....	55
10.5.5.	Test screenshot.....	77
10.6.	Mean power and amplifier/booster gain.....	198
10.6.1.	Requirements.....	198
10.6.2.	Test configuration.....	198
10.6.3.	Test procedures.....	199
10.6.4.	Test results.....	200
10.7.	Noise figure.....	205
10.7.1.	Requirements.....	205
10.7.2.	Test configuration.....	205
10.7.3.	Test procedures.....	206
10.7.4.	Test results.....	207
10.7.5.	Test screenshot.....	208
10.8.	Out-of-band/out-of-block emissions.....	213
10.8.1.	Requirements.....	213
10.8.2.	Test configuration.....	214
10.8.3.	Test procedures.....	215
10.8.4.	Test results.....	216
10.8.5.	Test screenshot.....	221
10.9.	Conducted spurious emissions.....	248
10.9.1.	Limit.....	248
10.9.2.	Test configuration.....	249
10.9.3.	Test procedures.....	250
10.9.4.	Test results.....	251
10.10.	Frequency stability.....	255
10.10.1.	Limit.....	255
10.10.2.	Test configuration.....	256
10.10.3.	Test procedures.....	257
10.10.4.	Test results.....	259
10.11.	Radiated spurious emissions.....	263
10.11.1.	Requirements.....	263
10.11.2.	Test configuration.....	265
10.11.3.	Test procedures.....	266
10.11.4.	Test results.....	268
11.	APPENDIX A. PHOTOGRAPH OF THE TEST CONNECTION DIAGRAM.....	276
12.	APPENDIX B. PHOTOGRAPHS OF EUT.....	279

- 12.1. Master Unit (MU)..... 279
 - 12.1.1. External photos..... 279
 - 12.1.2. Internal photos..... 283
- 12.2. Remote Unit (MU) 309
 - 12.2.1. External photos..... 309
 - 12.2.2. Internal photos..... 312
- 12.3. Optical Expansion Unit (FOU)..... 341
 - 12.3.1. External photos..... 341
 - 12.3.2. Internal photos..... 344

----- **The following blanks** -----

1. Applicant information

1.1. Client information

Name: Comba Telecom Network Systems Limited
Address: Flat/Rm 10, 3/F, Bio-Informatics Ctr, 2 Science Park West Avenue, HK Science Park, Pak Shek Kok, N.T. Hong Kong

1.2. Manufacturer and Factory

Name: Comba Network Systems Company Limited
Address: No.10 Shenzhou Road, Guangzhou Science City, Guangzhou 510663, Guangdong, P.R. China
Factory: Comba Telecom Technology (Guangzhou) Ltd.
Address: No.6 Jinbi Road, Economics and Technology Development District, Guangzhou Guangdong China

2. General description of EUT

2.1. Basic description of EUT

Product Name: Public Safety UHF DAS Master Unit
Product Model: RX45V2F-A-48
Adding Model: RX45V2F-A-AC
Trade Name: Comba
Power Supply: Typical DC input power: DC -48V and Typical output power: DC -28V
Or
Typical AC input power: AC 110V, 50/60Hz and Typical output power: DC -28V
Power cord: AC power cord (4m)
Frequency Band: Downlink: 450MHz ~ 512MHz, Uplink: 450MHz ~ 512MHz
Nominal Output Power: Master Unit and System:
Downlink: 36dBm; Uplink: 30dBm
Nominal Gain: Master Unit:
Downlink: 102dB, Uplink: 102dB
System Gain:
Downlink: 105dB, Uplink: 102dB
EUT Operating Temperature: -33°C to +55°C
Operating Humidity: 5% to 95%
Antenna Type: N/A

NOTE 1: The device is a Narrowband device, which belongs to Class A signal booster.

NOTE 2: The device provides two PSU power supply modes by manufacturer's statement, one Typical is DC-48V input, the other Typical is AC 110V, 50Hz / 60Hz input. Except for the different PSU power supply mode input and arrester, the power supply output to the device is the same, all other electrical parameters have the same circuit schematic, components, critical components and also the same construction. please see the following the differences below:

PSU power

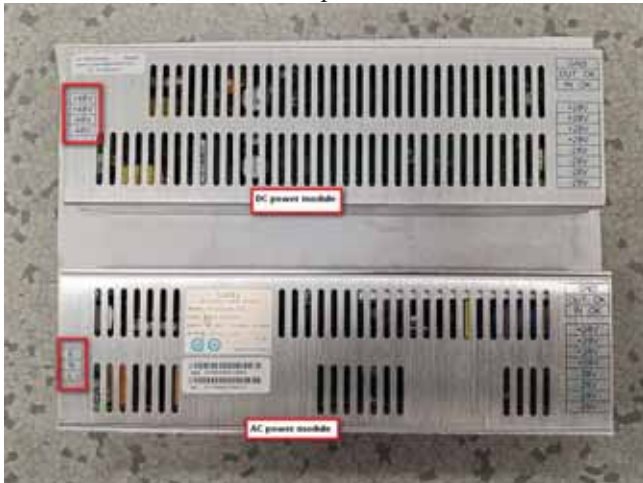

Arrester



NOTE 3: The device is an outdoor device, the device does not provide antenna by Manufacturer's statement, but it is required that the Antenna gain shall not exceed 0 dBi for Downlink and Uplink when the project is used by Manufacturer's statement.

NOTE 4: In this report, the main model has been tested, while the additional model has tested: Mean power and amplifier/booster gain, conducted spurious emissions and radiated spurious emissions.

NOTE 5: According to the device signal flow, the device supports independent uplink and downlink input/output, and system uplink output. Therefore, this report provides single device uplink and downlink test and system uplink test.

NOTE 6: According to the system configuration provided by the manufacturer, the minimum configuration of the system test is 1 MU, 1 FOU and 1 RU.

MU means Master Unit; FOU means Optical Expansion Unit; RU means Remote Unit;

----- The following blanks -----

2.2. Test signal modulation description

According to FCC PART 2.202 (g), Table of necessary bandwidths follow:

2.2.1. Analog signals

Emission Designator	Description	Modulation type	M (modulation Freq, kHz)	R (Rate, baud)	D (Deviation, kHz)	K (numeric constant)	S (Symbols)	Bandwidth Calculation	Necessary Bandwidth
4K00F1E	Narrowband Analog FM Voice	FM	1.0	--	1	1.0	--	$B_n=2M+2DK$	4.0
11K0F3E	Narrowband Analog FM Voice	FM	3.0	--	2.5	1.0	--	$B_n=2M+2DK$	11.0
16K0F3E	Wideband Analog FM Voice	FM	3.0	--	5.0	1.0	--	$B_n=2M+2DK$	16.0

2.2.2. Digital signals

Emission Designator	Description	Modulation type	M (modulation Freq, kHz)	R (Rate, baud)	D (Deviation, kHz)	K (numeric constant)	S (Symbols)	Bandwidth Calculation	Necessary Bandwidth
8K10F1E	P25 Phase I C4FM Voice	4FSK	--	9600	1.8	0.916	4	$B_n=(R/\log_2S)+2DK$	8.1
8K10F1D	P25 Phase I C4FM Data	4FSK	--	9600	1.8	0.916	4		8.1
8K10F1W	P25 Phase II H-CPM Voice/Data	4FSK	--	9600	1.8	0.916	4		8.1
9K80F1E	P25 Phase II H-DQPSK Voice	QPSK	--	12000	--	0.817	4	$B_n=2RK/\log_2S$	9.8
9K80F1D	P25 Phase II H-DQPSK Data	QPSK	--	12000	--	0.817	4		9.8

NOTE: In the above test signal modes, the typical signal and the worst mode signal are used as representatives in this test. the specific test signal types are as follows:

Emission Designator	Description	Modulation type	M (modulation Freq, kHz)	R (Rate, baud)	D (Deviation, kHz)	K (numeric constant)	S (Symbols)	Bandwidth Calculation	Necessary Bandwidth
4K00F1E	Narrowband Analog FM Voice	FM	1.0	--	1	1.0	--	$B_n=2M+2DK$	4.0
11K0F3E	Narrowband Analog FM Voice	FM	3.0	--	2.5	1.0	--	$B_n=2M+2DK$	11.0
16K0F3E	Wideband Analog FM Voice	FM	3.0	--	5.0	1.0	--	$B_n=2M+2DK$	16.0
8K10F1D	P25 Phase I C4FM Data	4FSK	--	9600	1.8	0.916	4	$B_n=(R/\log_2S)+2DK$	8.1
9K80F1D	P25 Phase II H-DQPSK Data	QPSK	--	12000	--	0.817	4	$B_n=2RK/\log_2S$	9.8

----- The following blanks -----

2.3. Signal Booster control process

2.3.1. System block

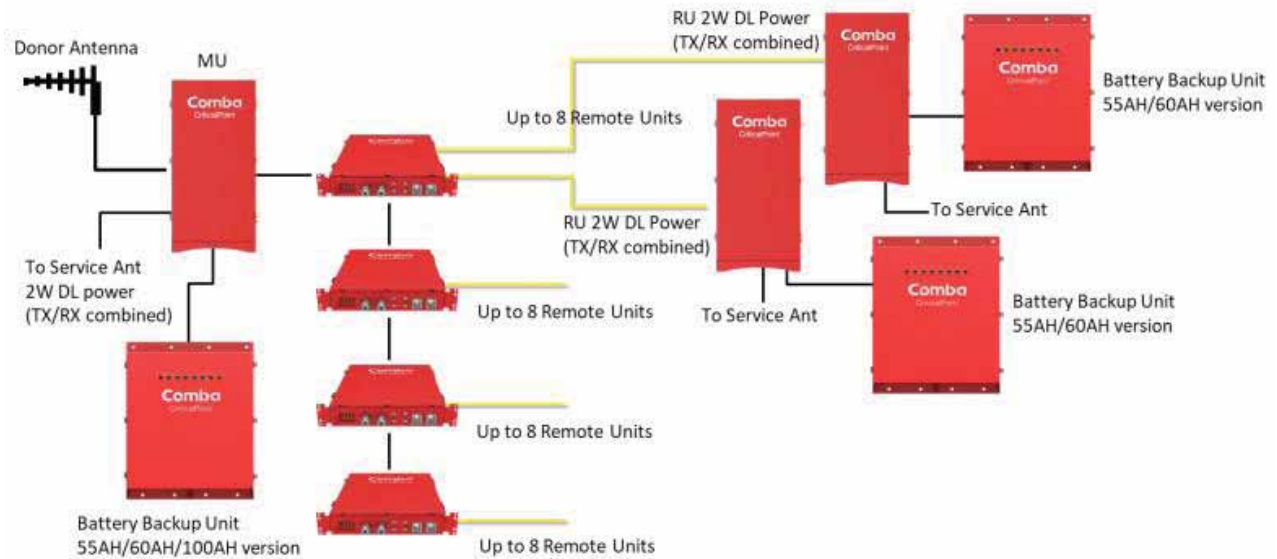

Figure 2.3-1 System block diagram

2.3.2. Signal control process

In the downlink path, the BTS signals are received by the donor antenna that is connected to the Master Unit. After the duplexer, the signals are sent to the LNA module for pre-amplification and to the digital RF integrated module for digital filtering and frequency conversion. Then the DL signals will be filtered via the duplexer, and then sent to the Expansion Unit(s), the RF signal is converted into an optical signal and then distributed to the Remote Unit(s) to over optical fiber. After amplification by the RU, the signals are transmitted at the MT port to the service antenna infrastructure.

In the uplink path, the mobile signals are received by the service antenna. After passing through the MT port duplexer, the signals are sent to the LNA and the integrated module for digital filtering, then the UL signals will be sent to the Expansion Unit(s), the RF signal is converted into an optical signal and then distributed to the Master Unit for filtering by the duplexer and power amplification. Finally, the uplink signals are sent to the donor antenna for transmission back to the BTS.

2.4. Description of Master Unit, Optical Expansion Unit, and Remote Unit connection port

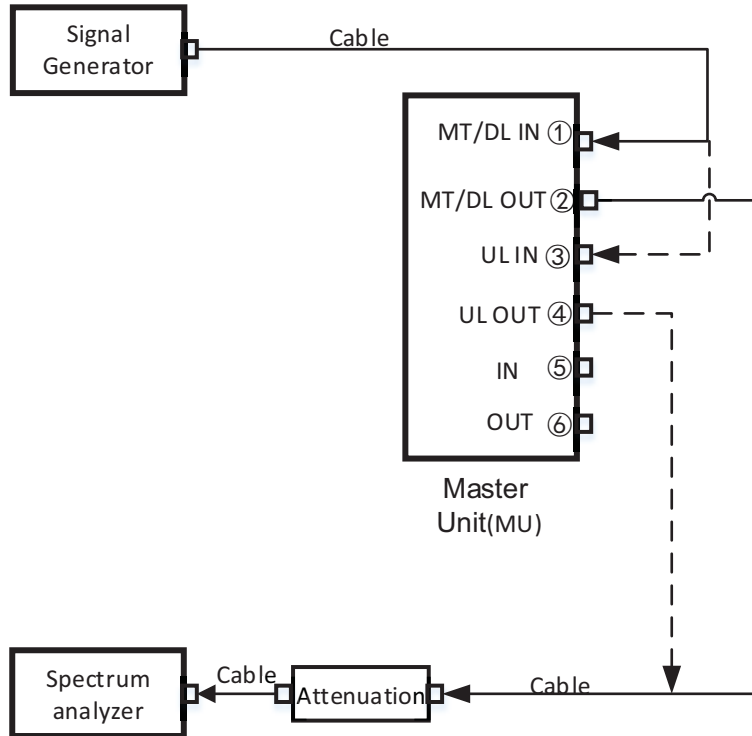

Figure 1 MU single device test connection diagram

NOTE 1: Both port ⑤ and port ⑥ of MU device need to power loads.

NOTE 2: The solid line means downlink and the dotted line means uplink.

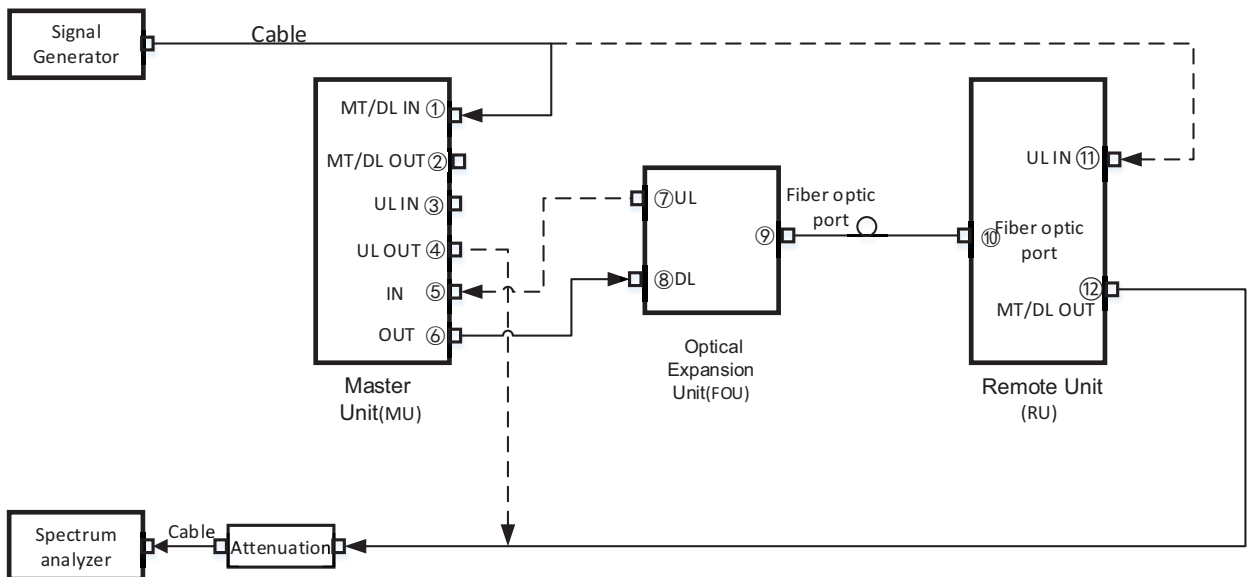

Figure 2 MU, FOU and RU system test connection diagram

NOTE 1: Both port ② and port ③ of MU device need to power loads.

NOTE 2: The solid line means downlink and the dotted line means uplink.

NOTE 3: If it is both a single device and a system, the single machine and the system can be combined together.

3. Related documents

FCC PART 2 (2020)

FCC PART 90 (2020)

KDB 935210 D05 Indus Booster Basic Meas v01r04

KDB 935210 D02 Signal Boosters Certification v04r02

KDB 971168 D01 Power Meas License Digital Systems v03r01

ANSI/TIA 603-E-2016

ANSI/TIA-102.CAAA-E-2016

ANSI C63.26-2015

----- **The following blanks** -----

4. Test result summary

Test Item	Test Requirements	Test Method	Reported	N/A
Test Frequency	KDB 935210 D02 APPENDIX D/Table D.3, FCC PART 2.1057, ANSI C63.26-2015 Clause 5.1.2	/	Reported only	
Input Signals	KDB 935210 D05 clause 4.1	/	Reported only	
AGC Threshold	KDB 935210 D05 clause 4.2	/	Reported only	
Out of Band Rejection	KDB 935210 D05 clause 4.3 FCC PART 90.219 (a) FCC PART 90.219 (d)((7))	KDB 935210 D05 clause 4.3	<input checked="" type="checkbox"/>	
Input VS output Comparison	KDB 935210 D05 clause 4.4 FCC PART 2.1049(c) FCC PART 90.219 (e)(4)(ii)	KDB 935210 D05 clause 4.4	<input checked="" type="checkbox"/>	
Mean power and amplifier/booster gain	KDB 935210 D05 clause 4.5 FCC PART 90.219 (e)(1)	KDB 935210 D05 clause 4.5	<input checked="" type="checkbox"/>	
Noise Figure	KDB 935210 D05 clause 4.6 FCC PART 90.219 (e)(2)	KDB 935210 D05 clause 4.6	<input checked="" type="checkbox"/>	
Out-of-band/out-of-block emissions	KDB 935210 D05 clause 4.7.2 FCC PART 2.1051 FCC PART 90.219 (d)(6)(i) FCC PART 90.219 (e)(3)	KDB 935210 D05 clause 4.7.2	<input checked="" type="checkbox"/>	
Conducted spurious emissions	KDB 935210 D05 clause 4.7.3 FCC PART 2.1051 FCC PART 90.219 (e)(3)	KDB 935210 D05 clause 4.7.3	<input checked="" type="checkbox"/>	
Frequency stability	KDB 935210 D05 clause 4.8 FCC PART 2 1055(a)(2) FCC PART 90.213 FCC PART 90.219 (e)(4)(i)	KDB 935210 D05/4.8 FCC PART 2 1055(b)	<input checked="" type="checkbox"/>	
Radiated spurious emissions	KDB 935210 D05 clause 4.9 FCC PART 2.1053 FCC PART 90.219 (e)(3)	KDB 935210 D05 clause 4.9 ANSIC63.26-2015/5.5 ANSI/TIA 603-E-2016 ANSI/TIA-102.CAAA-E-2016	<input checked="" type="checkbox"/>	

NOTE: mean that test needs to be performed.

5. About Signal Booster

According to the basic information of EUT (the device is a broadband device) and FCC part 90.219 (a) and KDB 935210 D02 APPENDIX A3.1 rules, this EUT belongs to PART 90 class A Industrial signal booster and it is a non SMR.

5.1. KDB 935210 D02 APPENDIX A3.1

A.3.1 Signal Booster (Section 90.219)

A **Signal Booster (Section 90.219)** is a device or system that automatically receives, amplifies, and retransmits signals from wireless stations into and out of building interiors, tunnels, shielded outdoor areas and other locations where these signals would otherwise be too weak for reliable communications. Signal booster systems may contain both Class A and Class B signal boosters as components. [Section 90.219(a)]

All **Section 90.219 boosters** are a type of Industrial Signal Booster, and are classified as either **Class A boosters** (narrowband) or **Class B boosters** (wideband). [R11] [Order, ¶ 15]

Note also that Consumer Signal Boosters are not defined for PLMRS or PSRS because licensees are considered to operate private services. Part 90 PLMR licensees typically obtain authorizations for individual narrowband channels or groups of channels to satisfy their own communication needs. Moreover, many Part 90 channels are interleaved and a licensee's channels may not be adjacent to one another, which presents unique considerations for signal boosters used with Part 90 PLMR services. [Order, ¶ 144]

a) Class A signal booster: A signal booster designed to retransmit signals on one or more specific channels. A signal booster is deemed to be a Class A signal booster if none of its passbands exceed 75 kHz. [Section 90.219(a)]

b) Class B signal booster: A signal booster designed to retransmit any signals within a wide frequency band. A signal booster is deemed to be a Class B signal booster if it has a passband that exceeds 75 kHz. [Section 90.219(a)]

Class B signal boosters may be deployed only at fixed locations; mobile operation of Class B signal boosters is prohibited (after November 1, 2014). [Section 90.219(d)(4)]

5.2. FCC part 90.219 (a) Definitions

§90.219 Use of signal boosters.

This section contains technical and operational rules allowing the use of signal boosters in the Private Land Mobile Radio Services (PLMRS). Rules for signal booster operation in the Commercial Mobile Radio Services under part 90 are found in §20.21 of this chapter.

<https://www.ecfr.gov/cgi-bin/text-idx?SID=2097cbedce8abb94d012e95530a44e05&mc=true&node=pt47.5.90&rpn=div5>

(a) *Definitions.* The definitions in this paragraph apply only to the rules in this section.

Class A signal booster. A signal booster designed to retransmit signals on one or more specific channels. A signal booster is deemed to be a Class A signal booster if none of its passbands exceed 75 kHz.

Class B signal booster. A signal booster designed to retransmit any signals within a wide frequency band. A signal booster is deemed to be a Class B signal booster if it has a passband that exceeds 75 kHz.

6. Test modes

<p>Test modes</p>	<p>TX mode: For MU device, “DT/DL IN” port of Master Unit (MU) is connected to the signal generator, “MT/DL” port is connected to the spectrum analyzer through attenuator, and the power of the EUT is turned on and signal is sent. while the system test, “MT / DL” port of MU is connected to the signal generator, and the “OUT1” port of MU is connected to "DL1" port of FOU through cable, then connected to RU through optical fiber from the optical port of FOU, output from “MT/DL” port of RU, and connected to the attenuator to the spectrum analyzer through cable, and the power of the EUT is turned on and signal is sent.</p> <p>RX mode: “UL IN” port of Master Unit (MU) is connected to the signal generator, “UL OUT” port is connected to the spectrum analyzer through attenuator, and the power of the EUT is turned on and signal is sent, while the system test, the Uplink signal is input from the "UL IN" port of the Remote Unit (RU), transmitted through the optical fiber to the Optical Expansion Unit (FOU), output from the port "UL1" to the "IN1" of Master Unit (MU), and the signal is output from the Master Unit(MU) "UL OUT" port</p>
-------------------	---

----- The following blanks -----

7. Laboratory and Accreditations

7.1. Laboratory

The tests & measurements refer to this report were performed by Shenzhen EMC Laboratory of Guangzhou GRG Metrology & Test Co., Ltd.

Testing Certificate Number: 2861.01

Add. : No.1301 Guanguang Road Xinlan Community, Guanlan Street, Longhua District Shenzhen, 518110, People's Republic of China.

P.C. : 518110

Tel : 0755-61180008

Fax : 0755-61180008

7.2. Accreditations

Our laboratories are accredited and approved by the following approval agencies according to GB/T 27025(ISO/IEC 17025:2017)

USA A2LA(Certificate#: 2861.01)

The measuring facility of laboratories has been authorized or registered by the following approval agencies.

Canada Industry Canada

USA FCC

Copies of granted accreditation certificates are available for downloading from our web site,
<http://www.grgtest.com>

----- **The following blanks** -----

8. Measurements uncertainty

Where relevant, the following measurement uncertainty levels have been estimated for tests performed on the EUT as specified in CISPR 16-4-2:

Measurement		Frequency	Uncertainty
Radiated Emission	Horizontal	30MHz~1000MHz	4.3dB
	Horizontal	1GHz~18GHz	5.6dB
	Vertical	30MHz~1000MHz	4.3dB
	Vertical	1GHz~18GHz	5.6dB

Measurement	Uncertainty
RF frequency	6×10^{-6}
RF power conducted	0.78dB
Occupied channel bandwidth	0.4%
Unwanted emission, conducted	0.68dB
Humidity	6%
Temperature	2°C

Note: This uncertainty represents an expanded uncertainty factor of $k=2$.

----- The following blanks -----

9. Equipments used during test

Name of Equipment	Manufacturer	Model	Serial Number	Calibration Due
Signal Generator	Agilent	E4438C	MY49072994	2022-05-15
Signal Generator	Agilent	E4432B	MY43350133	2022-05-07
Signal Generator	Agilent	E5182A	MY48180411	2022-10-12
Vector Signal Generator	R&S	SMBV 100A	260996	2022-01-21
Signal Generator	R&S	SMB 100A	109290	2022-01-11
Spectrum analyzer	R&S	FSV30	104381	2022-02-21
Spectrum analyzer	R&S	FSV30	103264	2022-10-31
Spectrum analyzer	Agilent	N9020B	MY59050667	2022-02-21
Spectrum analyzer	Agilent	N9020A	MY51285942	2022-05-15
Power splitter	WEINSCHEL	1580	SL767	2022-03-02
SNS Series Noise Source	Agilent	346B	MY44422241	2022-05-15
NFA Series Noise Figure Analyzer	Agilent	N8973A	MY45071191	2022-07-21
DC power supply	YISheng	YSRLD-605	2015052010	2022-09-03
Frequency meter	Suin	SS7300	6E5042026	2022-04-23
Voltage regulator	Qingdaoqingzhi	TDGC2J-5	GRGTAG2013026	/
Digital multimeter	Fluke	F15B+	44750292WS	2022-01-13
Isolator	CIL	M1005L001MN00 400~500	100680905	/
Isolator	CIL	M1005L001MN00 400~500	100680906	/
Attenuation	Shanghaihua xiang	DTS50-30dB-4G	54451395	/
Attenuation	Shanghaihua xiang	DTS50-40dB-4G	11042234	/
Temp & Humidity chamber	Deli	/	013545	2022-06-07
Radiated emissions				
Receiver	R&S	ESU26	100526	2022-08-20

Receiver	R&S	ESU40	100106	2022-10-10
Bi-log Antenna	Schwarzbeck	VULB 9160	9160-3402	2022-10-27
Bi-Log Antenna	ETS-lindgren	3142C	75971	2022-12-14
Horn Antenna	Schwarzbeck	BBHA9120	I00309	2022-09-11
Horn Antenna	ETS	3117 C	00075824	2022-01-21
Broadband Amplifiers	Schwarzbeck	BBV9718	00246	2022-08-16
Semi-anechoic chamber	ETS-lindgren	966(RFD-F/A-100)	3730	2022-09-19

----- The following blanks -----

10. Radio technical requirement specification

10.1. Test Frequencies

Test requirement: KDB 935210 D02 APPENDIX D/Table D.3
 FCC PART 2.1057
 ANSI C63.26-2015 Clause 5.1.2

10.1.1. Requirements

According to FCC regulations, FCC part 2.1057, ANSI C63.26-2015 clause 5.1.2 and KDB 935210 D02 Appendix D / table D.3 have relevant frequency band requirements.

(1) FCC PART 2.1057

§2.1057 Frequency spectrum to be investigated.

(a) In all of the measurements set forth in §§2.1051 and 2.1053, the spectrum shall be investigated from the lowest radio frequency signal generated in the equipment, without going below 9 kHz, up to at least the frequency shown below:

(1) If the equipment operates below 10 GHz: to the tenth harmonic of the highest fundamental frequency or to 40 GHz, whichever is lower.

(2) If the equipment operates at or above 10 GHz and below 30 GHz: to the fifth harmonic of the highest fundamental frequency or to 100 GHz, whichever is lower.

(3) If the equipment operates at or above 30 GHz: to the fifth harmonic of the highest fundamental frequency or to 200 GHz, whichever is lower.

(b) Particular attention should be paid to harmonics and subharmonics of the carrier frequency as well as to those frequencies removed from the carrier by multiples of the oscillator frequency. Radiation at the frequencies of multiplier stages should also be checked.

(c) The amplitude of spurious emissions which are attenuated more than 20 dB below the permissible value need not be reported.

(d) Unless otherwise specified, measurements above 40 GHz shall be performed using a minimum resolution bandwidth of 1 MHz.

----- The following blanks -----

(2) ANSI C63.26-2015 Clause 5.1.2

5.1.2 Number of fundamental frequencies to be tested in EUT transmit band

5.1.2.1 General requirement

Measurements of transmitters shall be performed and, if required, reported for each frequency band in which the EUT can be operated with the device transmitting at the number of frequencies in each band specified in Table 2.

²⁴ See 47 CFR 2.1057.

ANSI C63.26-2015
American National Standard for Compliance Testing of Transmitters Used in Licensed Radio Services

Table 2—Number of frequencies to be tested

Frequency range over which EUT operates	Number of frequencies	Location in frequency range of operation
1 MHz or less	1	Middle
1 MHz to 10 MHz	2	1 near top and 1 near bottom
More than 10 MHz	3	1 near top, 1 near middle, and 1 near bottom

(3) KDB 935210 D02 APPENDIX D/Table D.3

Table D.3 – Various Part 90 PLMRS band allocations, rule parts/sections, and service types for Section 90.219 purposes (for info only – see rules for details, also KDB Publication 634817 [R14])

F _L (MHz)	–	F _H (MHz)	Rule(s)	Misc. Notes
150	–	150.05	Federal (non-FCC)	
150.05	–	150.8	90.265	
150.8	–	162.0125	90	
162.0125	–	173.2	90.265	
173.2	–	173.4	90	
173.4	–	174	Federal (non-FCC)	
406.1	–	420	90.265	
420	–	421	ULS presently shows no licensees for 420-420.9 MHz	
421	–	430	90	
430	–	450	Not available under 90 Subparts B, C land mobile service	
450	–	470	90 (selected bands)	
470	–	512	90	
746	–	757	27.5(b)(3) Block C; 90 not available	
757	–	758	27.5(b)(1) Block A; 90 not available	
758	–	768	90-R, Public Safety (PS) Broadband (FirstNet)	B9B (LTE)
768	–	769	PS Guardband	
769	–	775	PS Narrowband	
775	–	776	27.5(b)(2) Block B; 90 not available	
776	–	787	27.5(b)(3) Block C; 90 not available	
787	–	788	27.5(b)(1) Block A; 90 not available	
788	–	798	90-R, Public Safety (PS) Broadband (FirstNet)	B9B (LTE)
798	–	799	PS Guardband	
799	–	805	PS Narrowband	
805	–	806	27.5(b)(2) Block B; 90 not available	
806	–	809	90 NPSPAC (PS) [90.617(a)(1)]	B9B/B9A

The EUT will utilize bands: 450MHz ~ 512MHz

10.1.2. Result

This project is only reported and checked, the frequency range of this EUT meets the above regulatory requirements.

----- **The following blanks** -----

10.2. Input Signals

Test requirement: KDB 935210 D05 clause 4.1

10.2.1. Requirements

According to FCC regulations, KDB 935210 D05 clause 4.1 have relevant input signals requirements.

The procedures in this clause are specific to EUTs intended for operating in the Private Land Mobile Radio Services (PLMRS) and Public Safety Radio Services (PSRS)⁵, which are governed under the provisions and requirements of the Part 90 rules (i.e., Section 90.219 applies).

Table 1 depicts signal types associated with PLMRS operations, which are to be considered as test signals to be used in performing compliance testing on PLMRS amplifiers, repeaters, and industrial boosters. Not all of the procedures in this clause will require using each of the signals listed in Table 1, because for

⁵ As explained in § 90.16, Public Safety Radio Services is part of the Public Safety Radio Pool, also known as the Public Safety Pool.

many EUTs a CW tone can adequately model the narrowband signals typically encountered within these services. For EUTs supporting digitally modulated signals, the intended operating signal types should be tested (e.g., P25 Phase 1, P25 Phase 2, TETRA, etc.), especially for PSRS devices. Devices intended for use in 700 MHz Public Safety Broadband spectrum shall be tested using a representative band-limited AWGN signal (99 % OBW of 4.1 MHz) or the applicable signal type (e.g., LTE).

Table 1—Test signals for PLMRS devices

Emission Designator	Modulation	Occupied Bandwidth	Channel Bandwidth	Audio Frequency
16K0F3E	FM	16 kHz	25 kHz	1 kHz
11K3F3E	FM	11.3 kHz	12.5 kHz	1 kHz
4K00F1E	FM	4 kHz	6.25 kHz	1 kHz
N/A	CW	N/A	N/A	N/A

10.2.2. Result

This project is only reported and checked.

----- The following blanks -----

10.2.3. Input Signals screenshot

10.2.3.1.P25 Phase I(C4FM) mode

10.2.3.1.1. Downlink

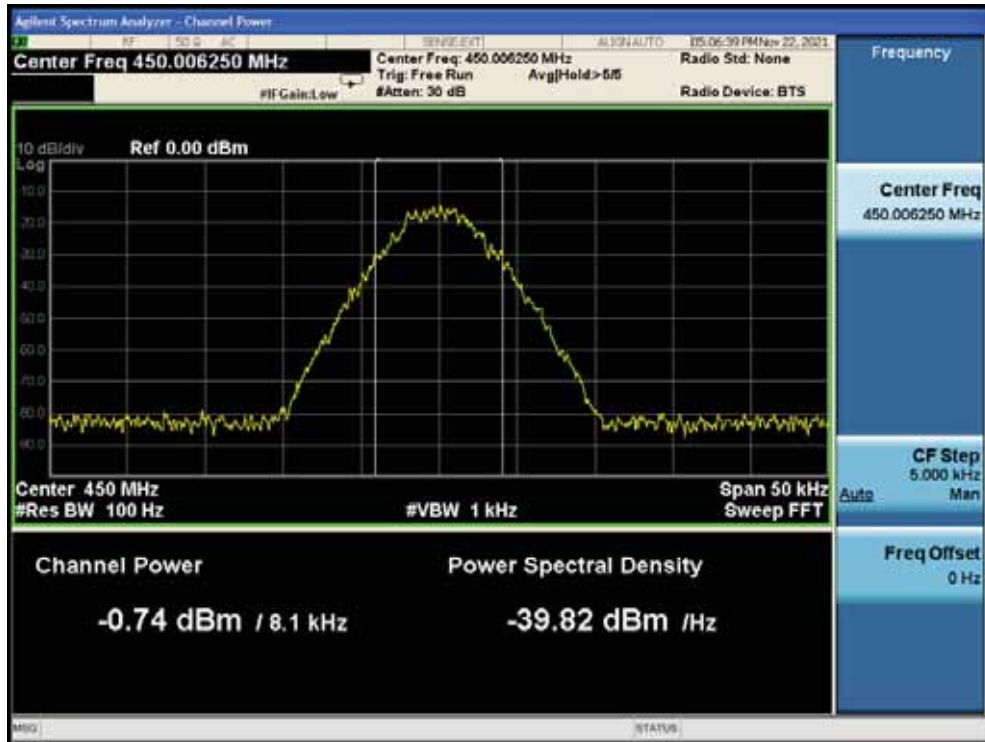

Low Frequency: 450.00625MHz

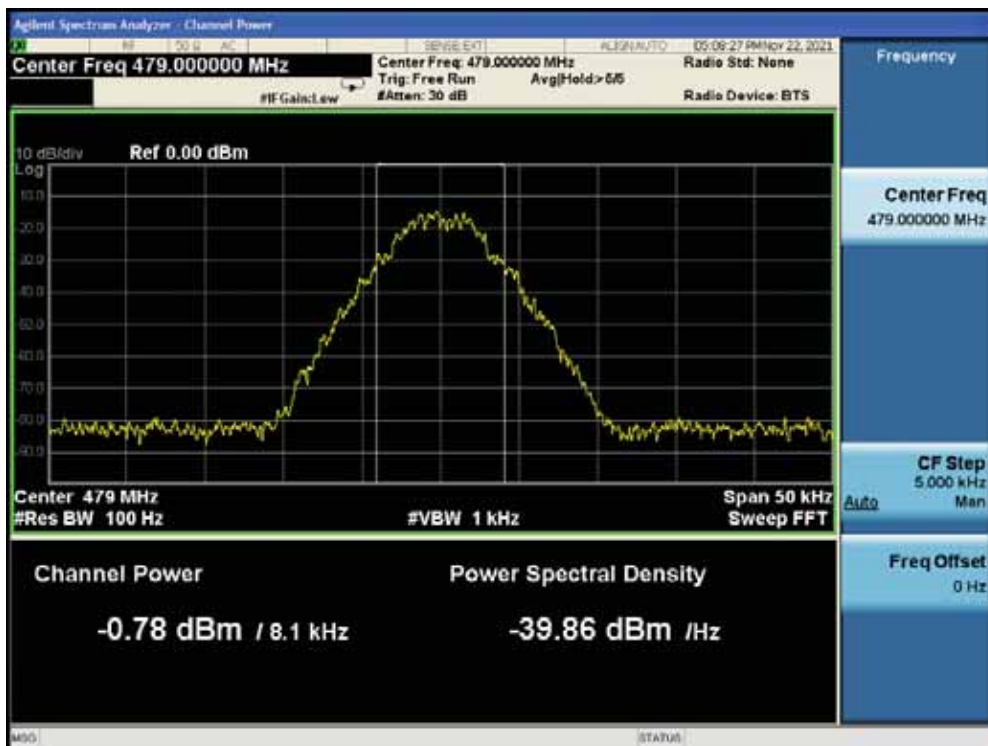

Middle Frequency: 479.0MHz



High Frequency: 508.99375MHz

10.2.3.1.2. Uplink

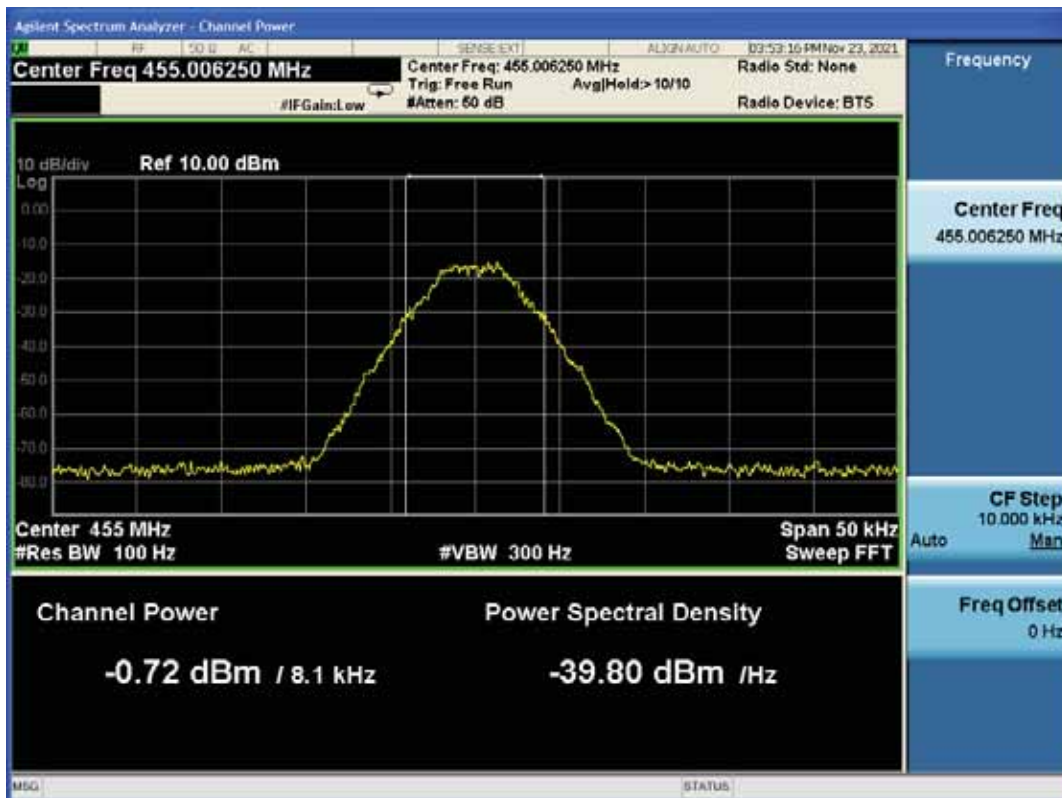

Low Frequency: 455.00625MHz

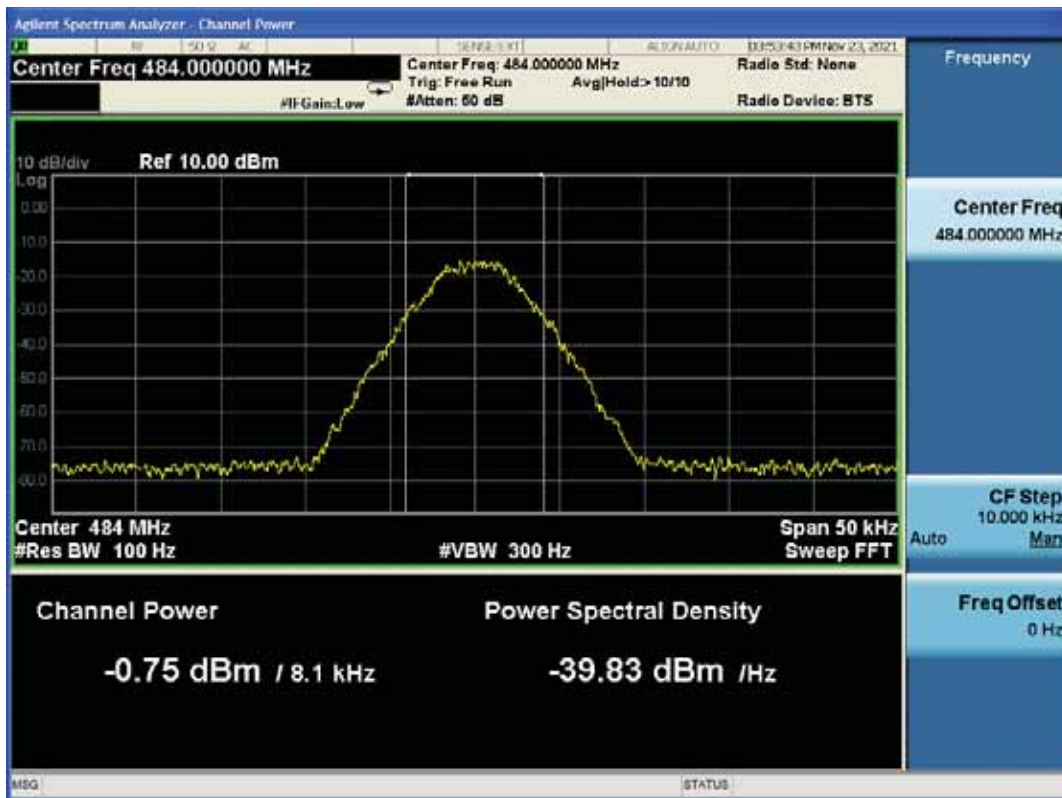

Middle Frequency: 484.0MHz

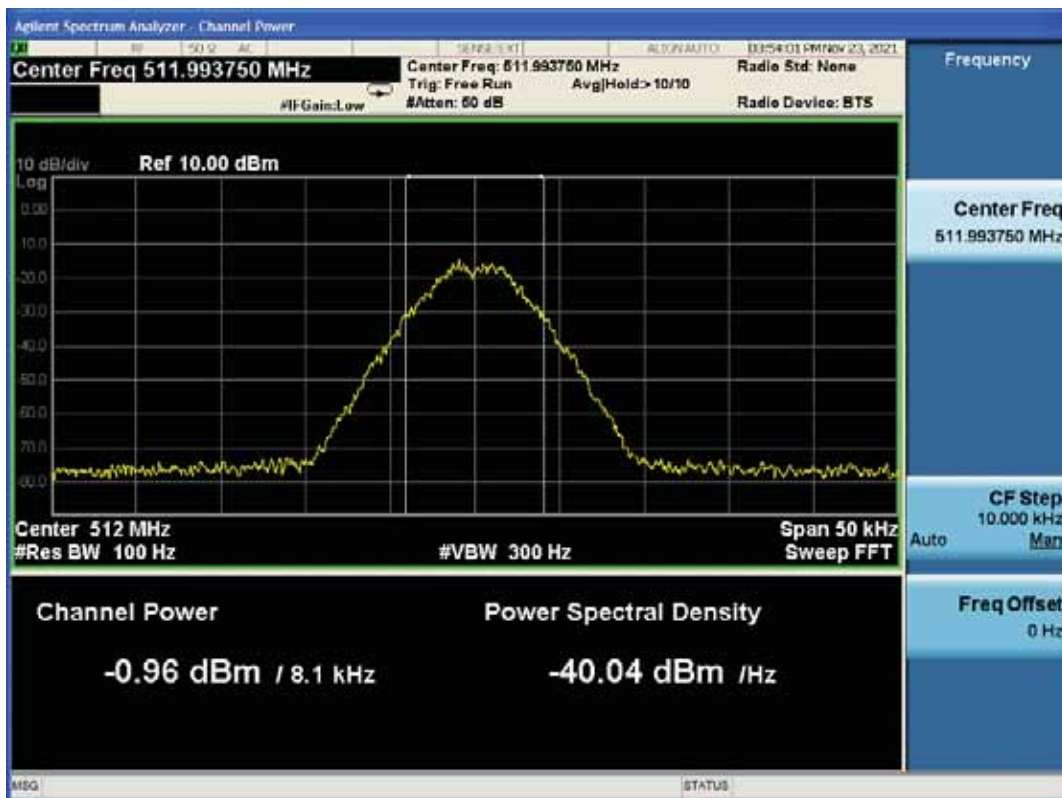

High Frequency: 511.99375MHz

10.2.3.2.P25 Phase II(H-DQPSK) mode

10.2.3.2.1. Downlink

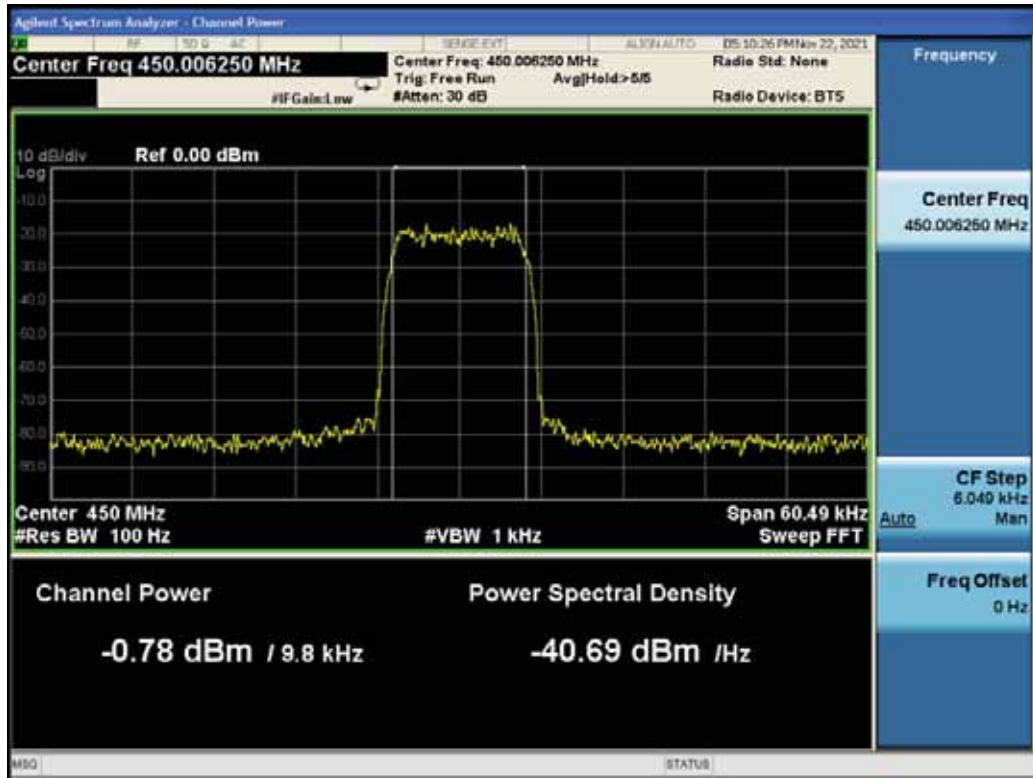

Low Frequency: 450.00625MHz

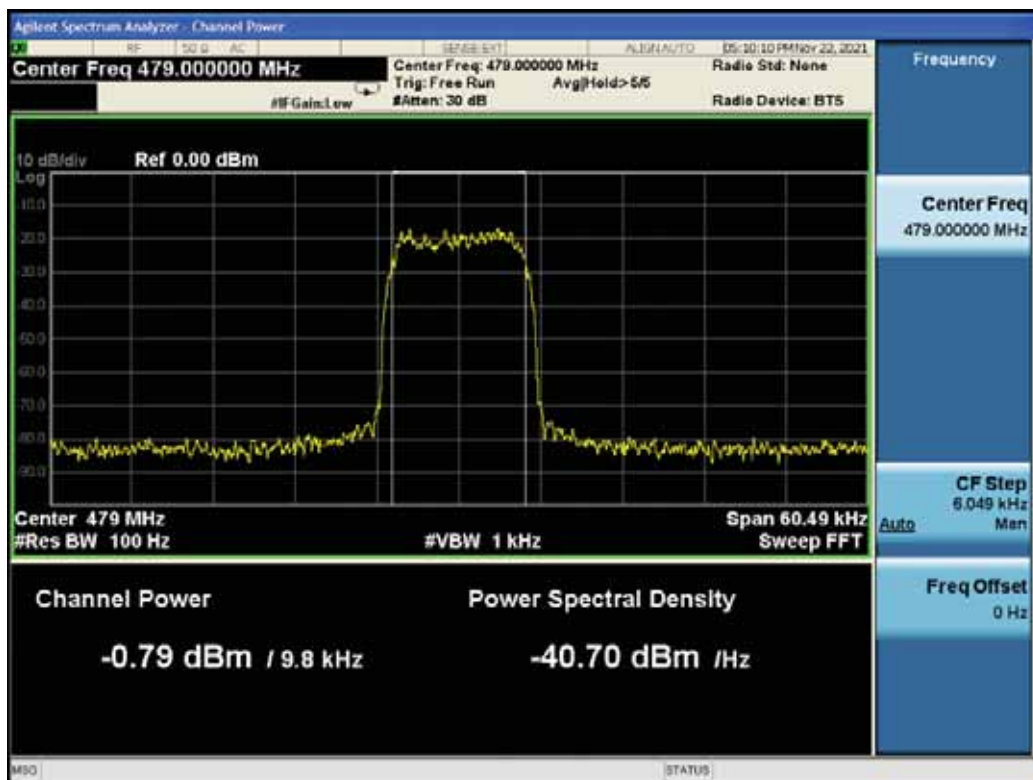

Middle Frequency: 479.0MHz

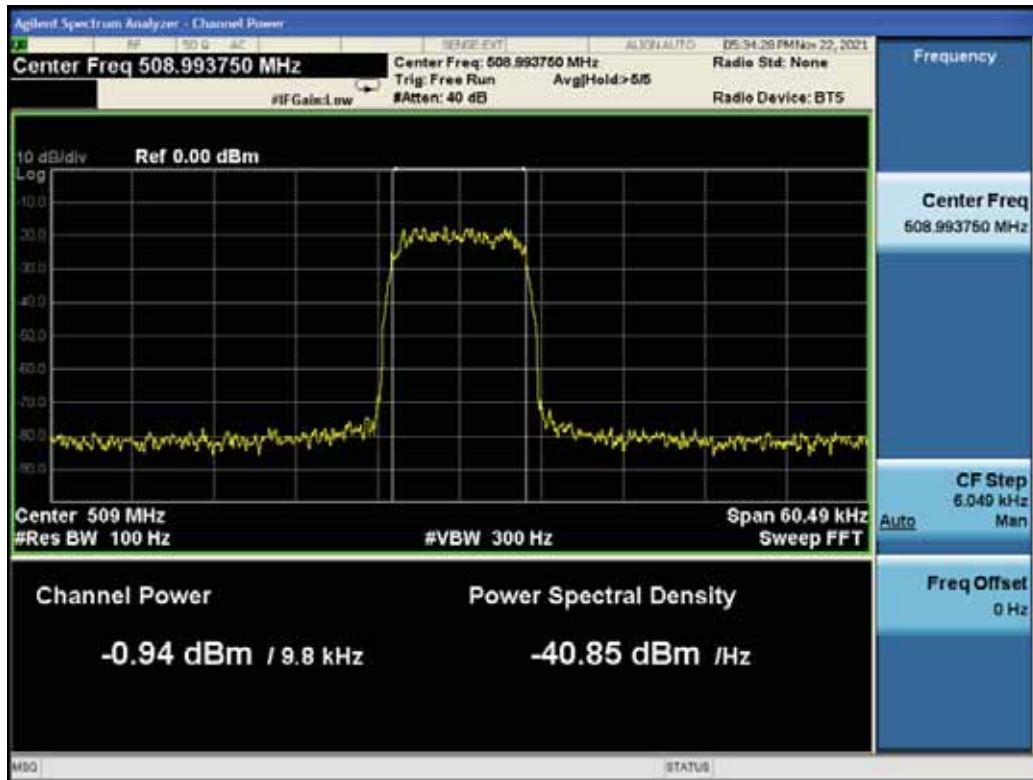

High Frequency: 508.99375MHz

10.2.3.2.2. Uplink



Low Frequency: 455.00625MHz

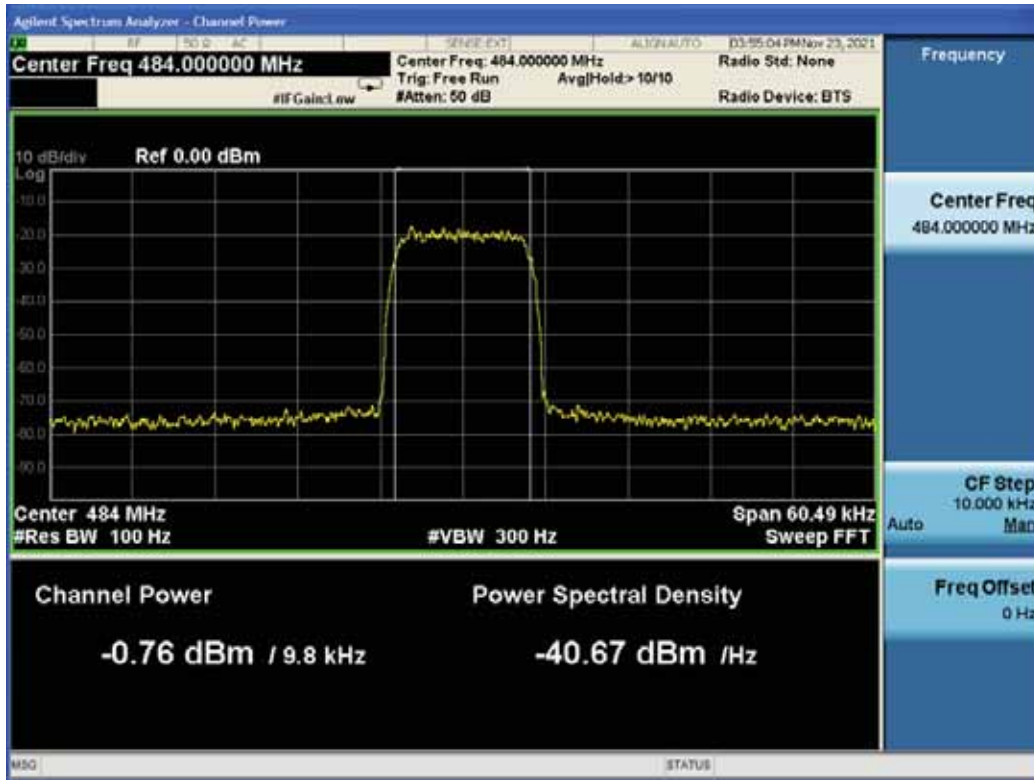

Middle Frequency: 484.0MHz

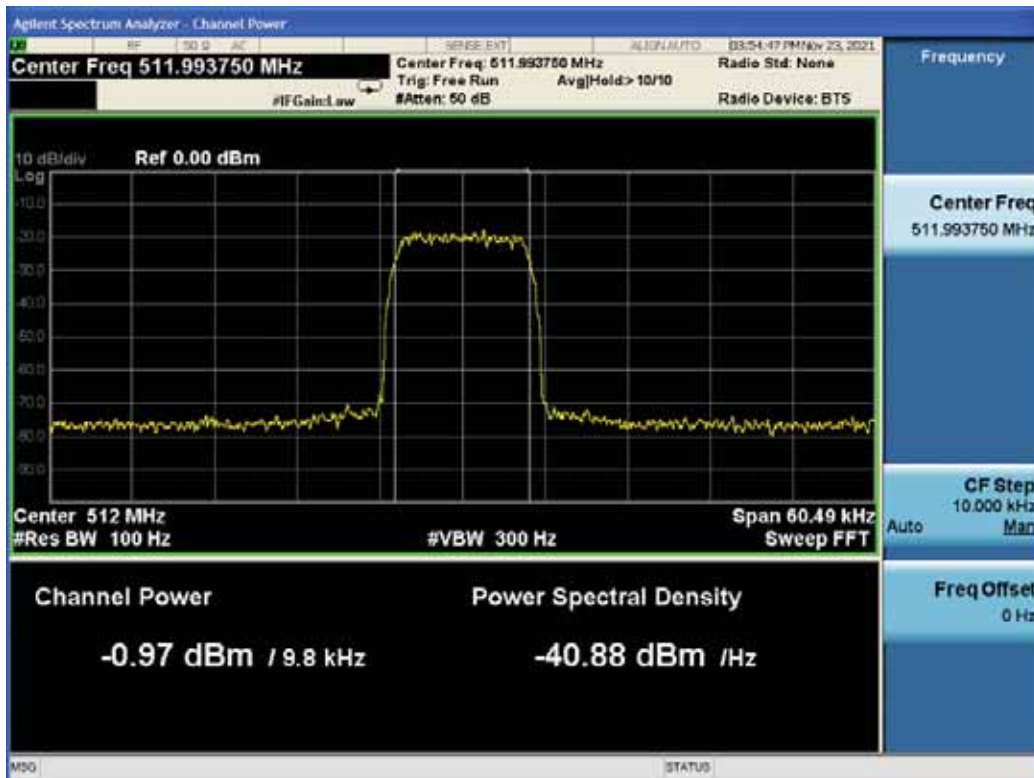

High Frequency: 511.99375MHz

10.2.3.3. Analog FM (6.25kHz)

10.2.3.3.1. Downlink

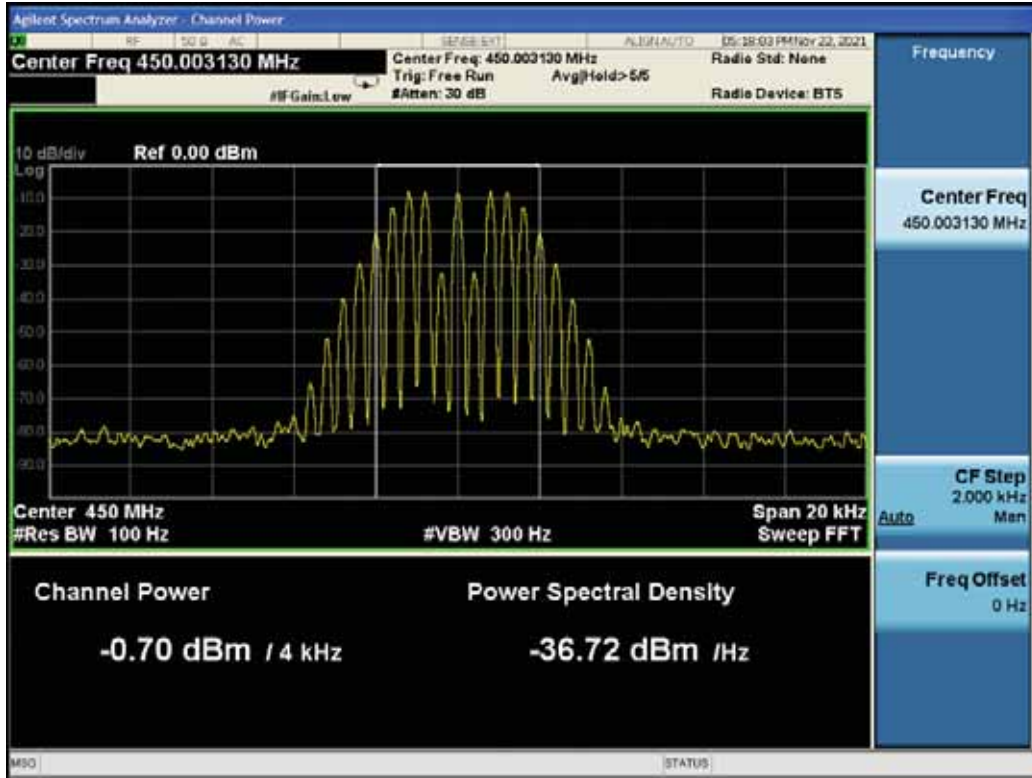

Low Frequency: 450.00313MHz

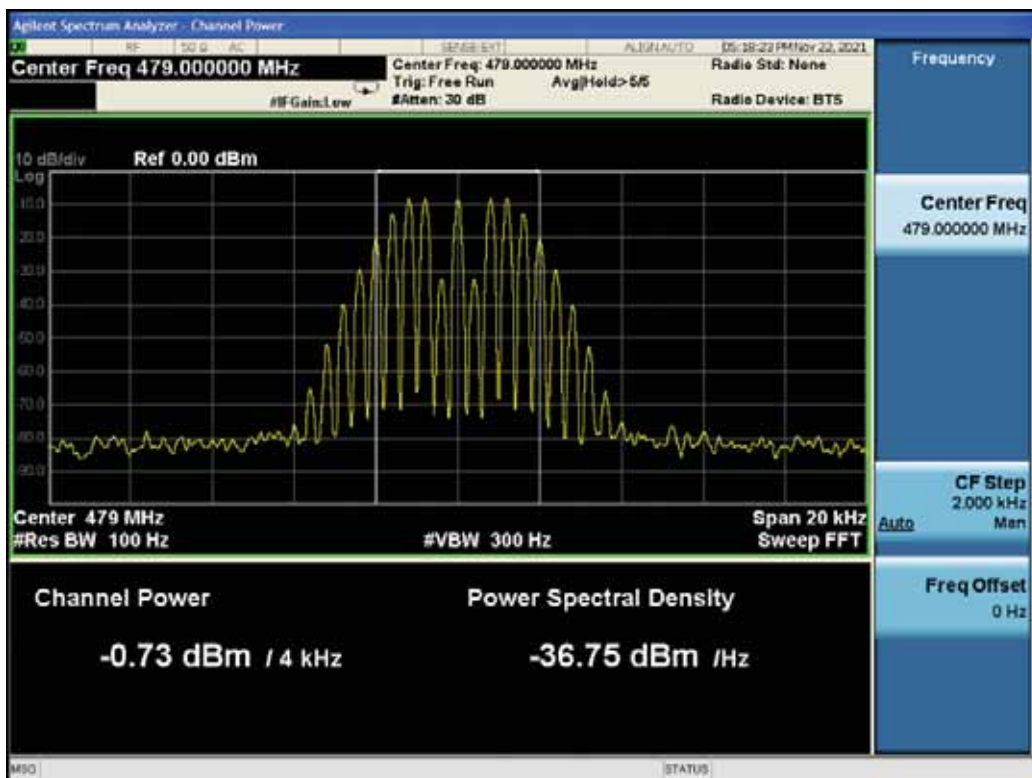

Middle Frequency: 479.0MHz

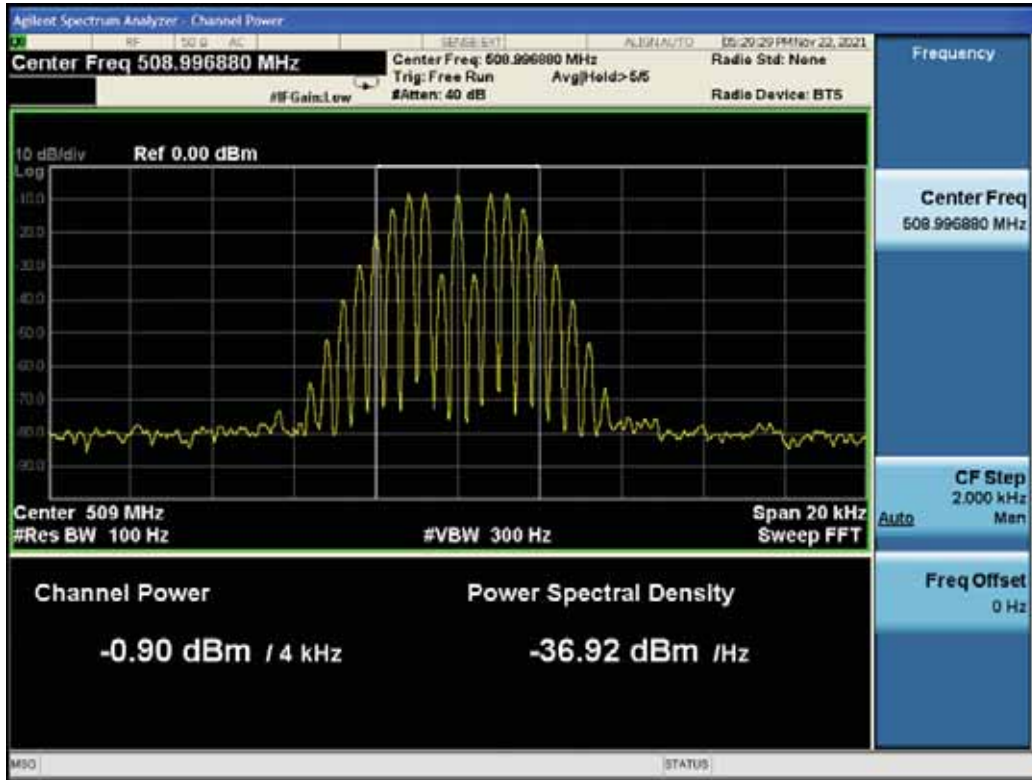

High Frequency: 508.99688MHz

10.2.3.3.2. Uplink

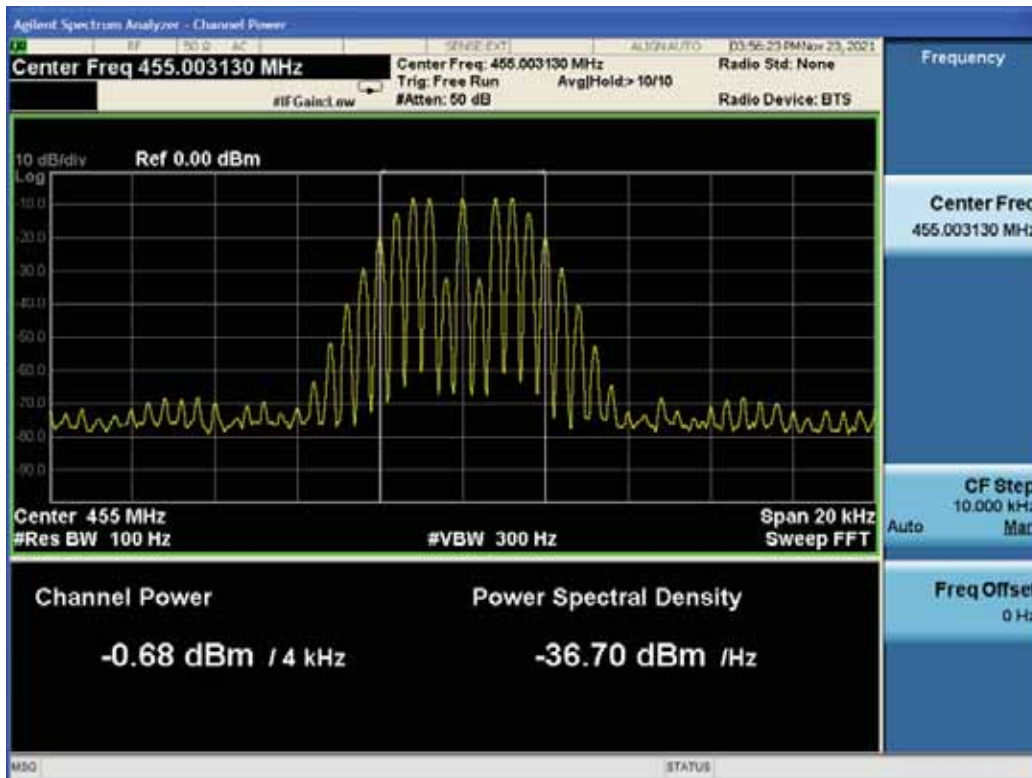

Low Frequency: 455.00313MHz

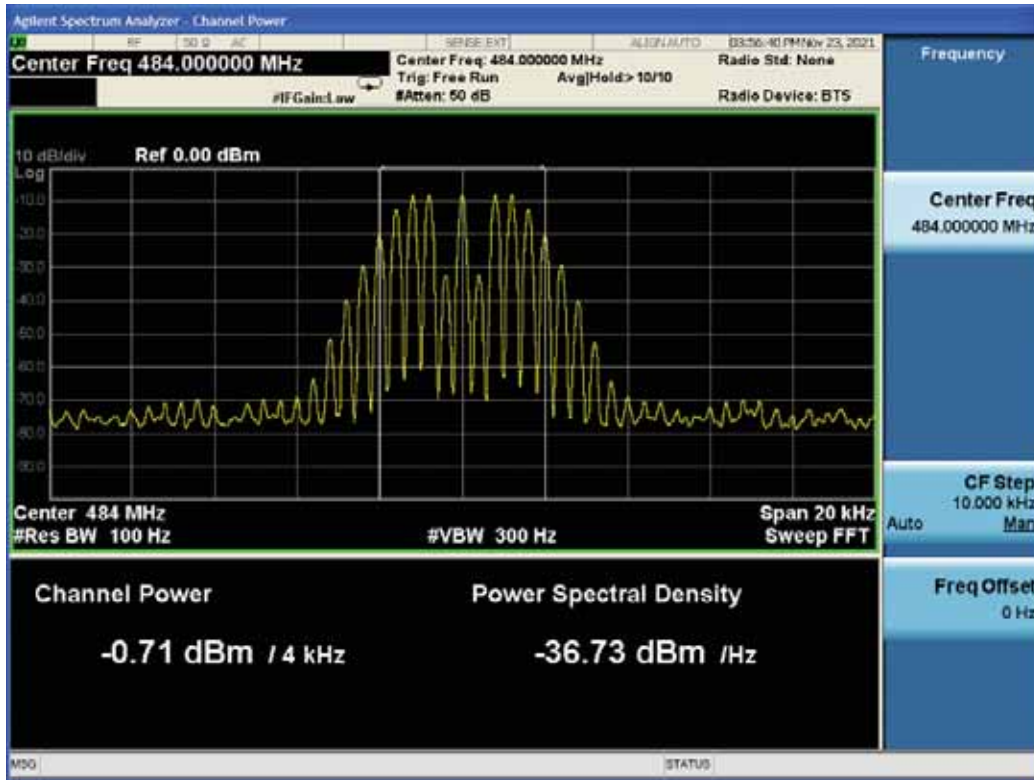

Middle Frequency: 484.0MHz

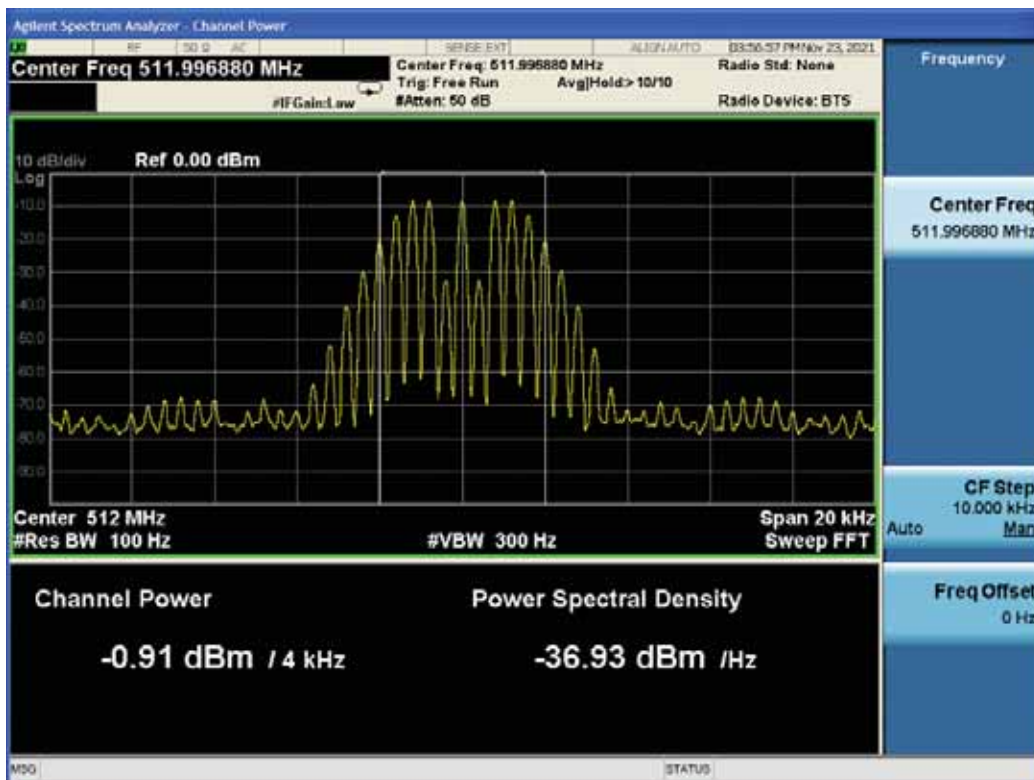

High Frequency: 511.99688MHz

10.2.3.4. Analog FM (12.5kHz)

10.2.3.4.1. Downlink

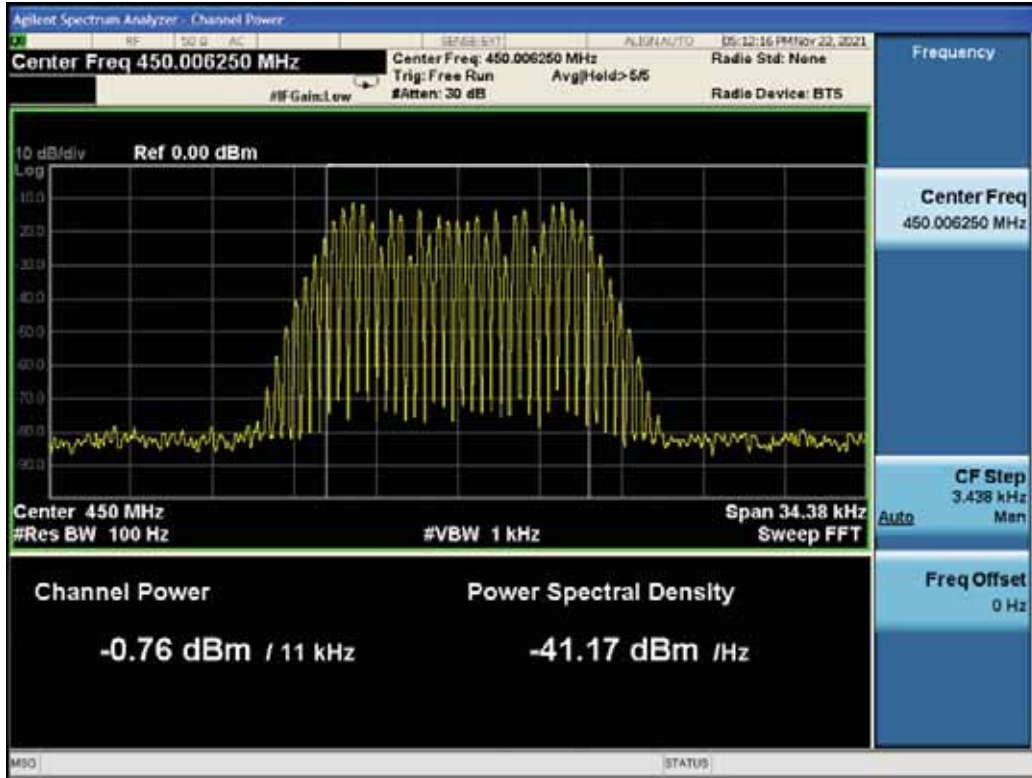

Low Frequency: 450.00625MHz

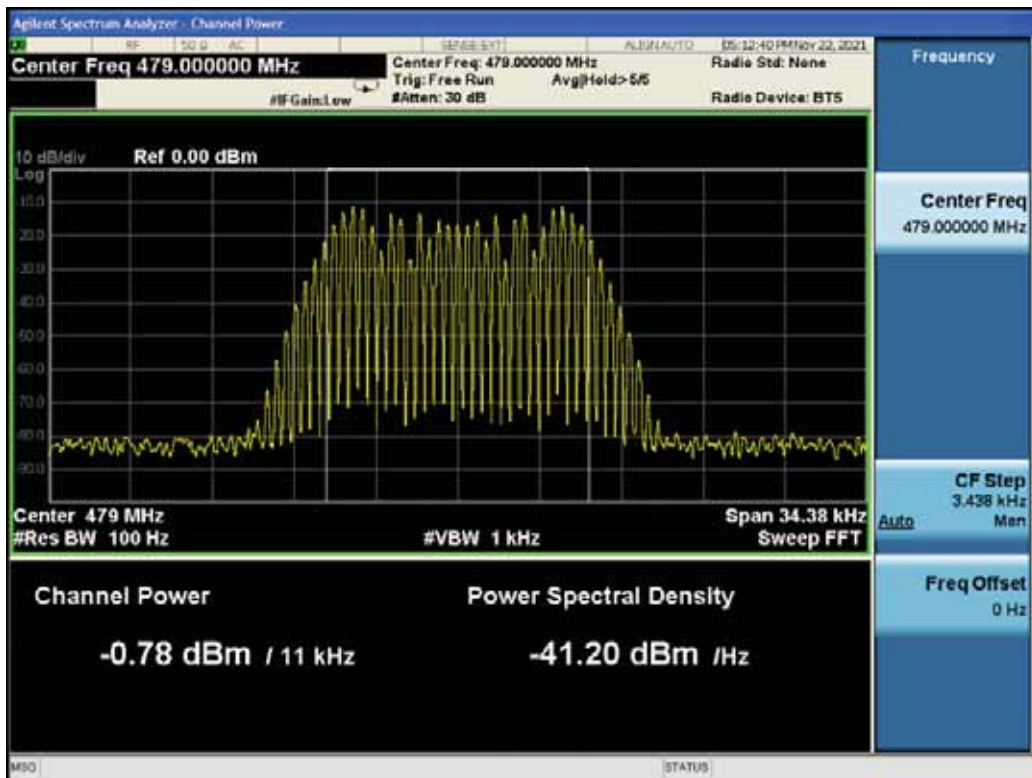

Middle Frequency: 479.0MHz

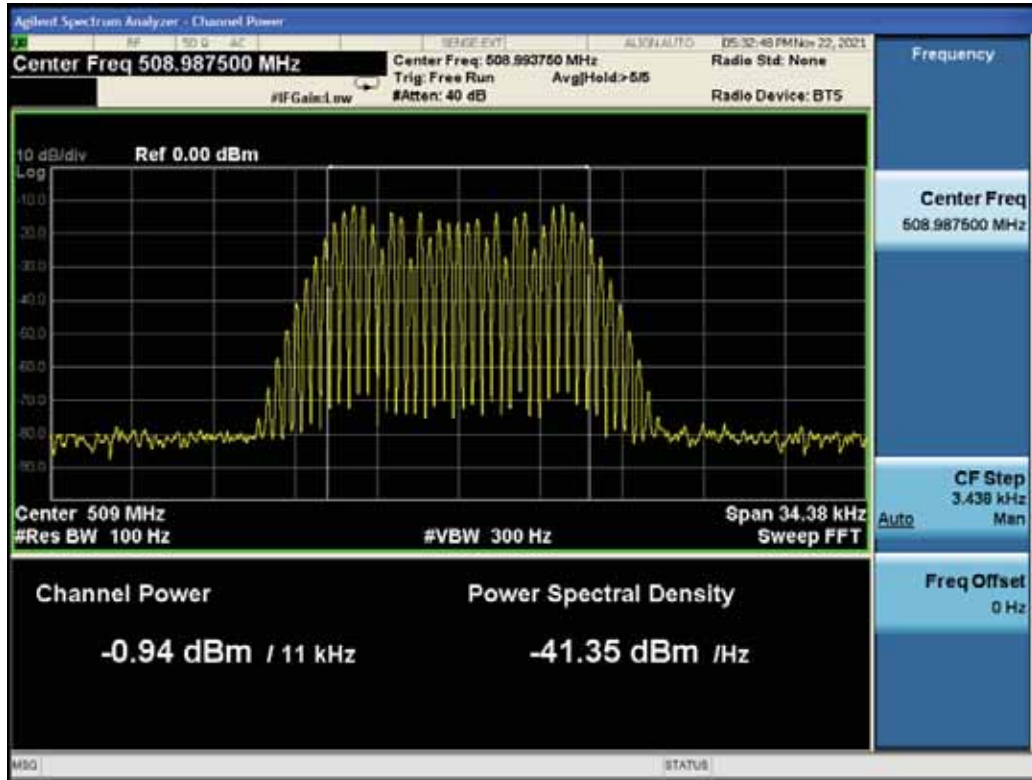

High Frequency: 508.99375MHz

10.2.3.4.2. Uplink

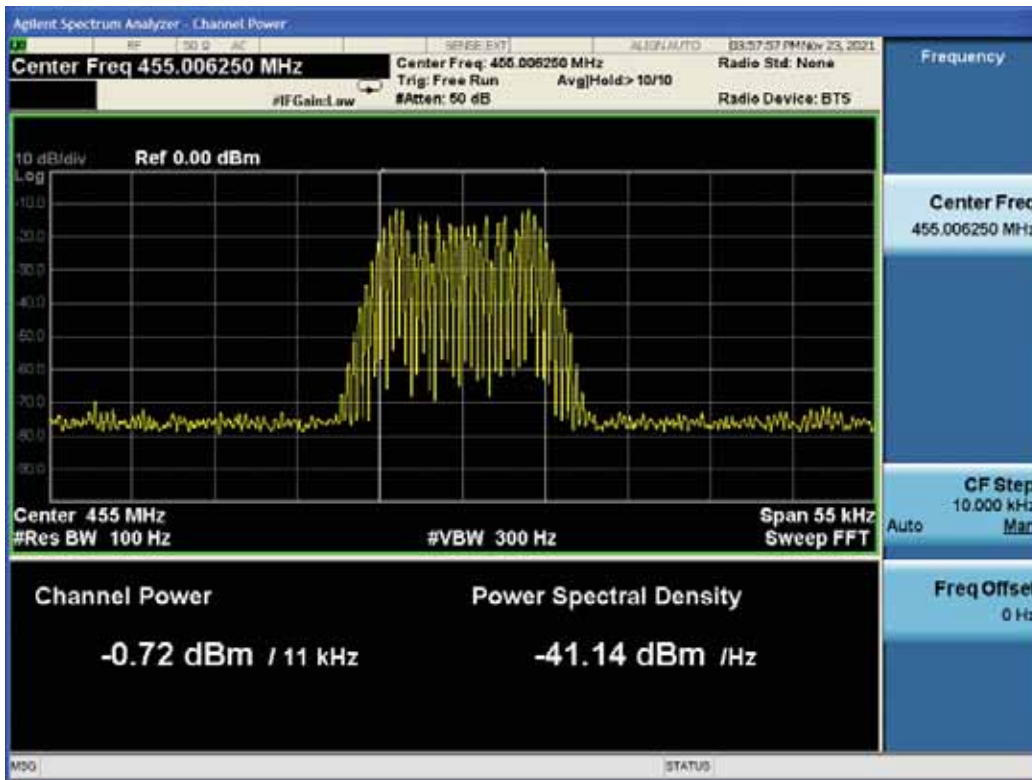

Low Frequency: 455.00625MHz

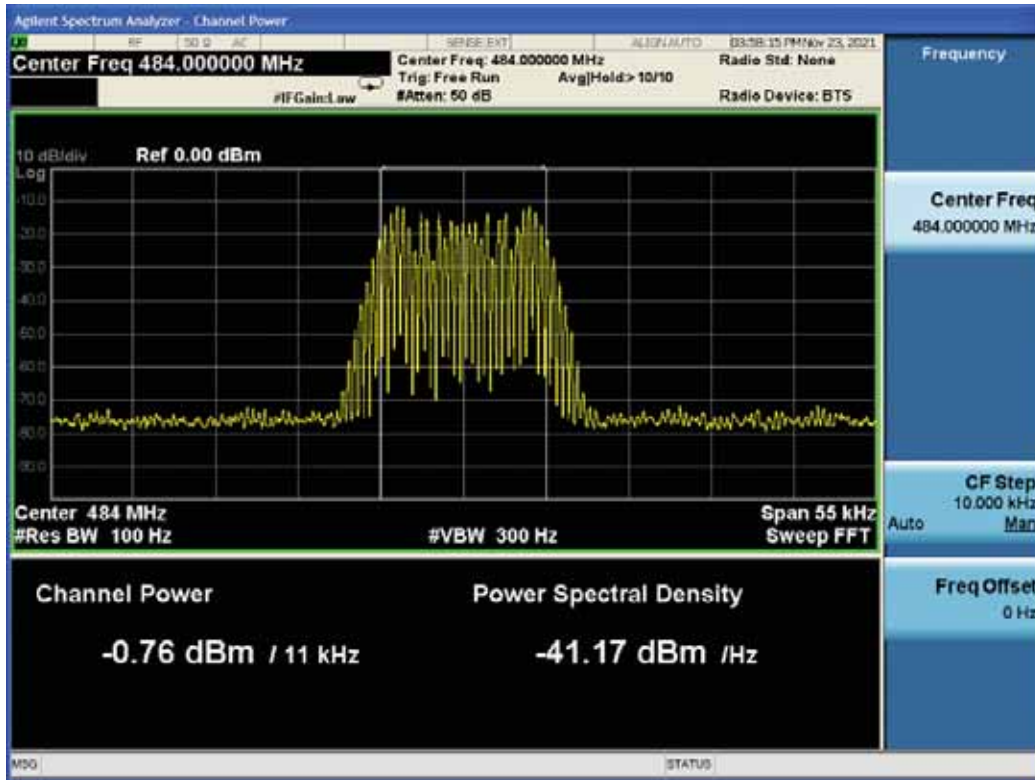

Middle Frequency: 484.0MHz

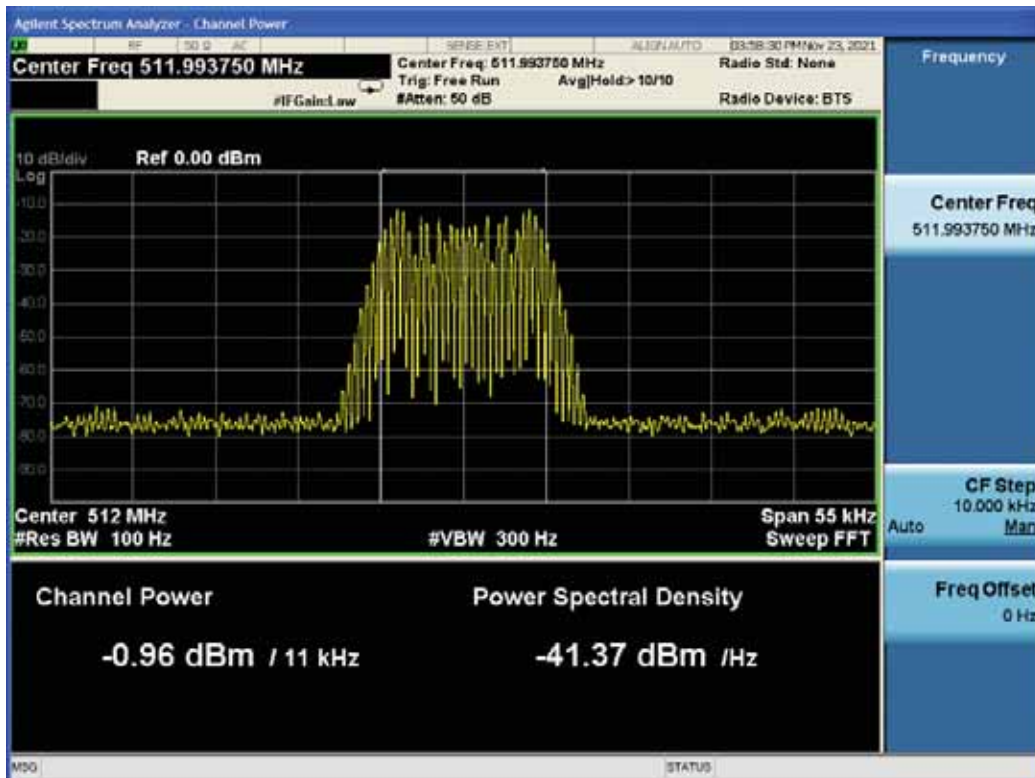

High Frequency: 511.99375MHz

10.2.3.5. Analog FM (25kHz)

10.2.3.5.1. Downlink

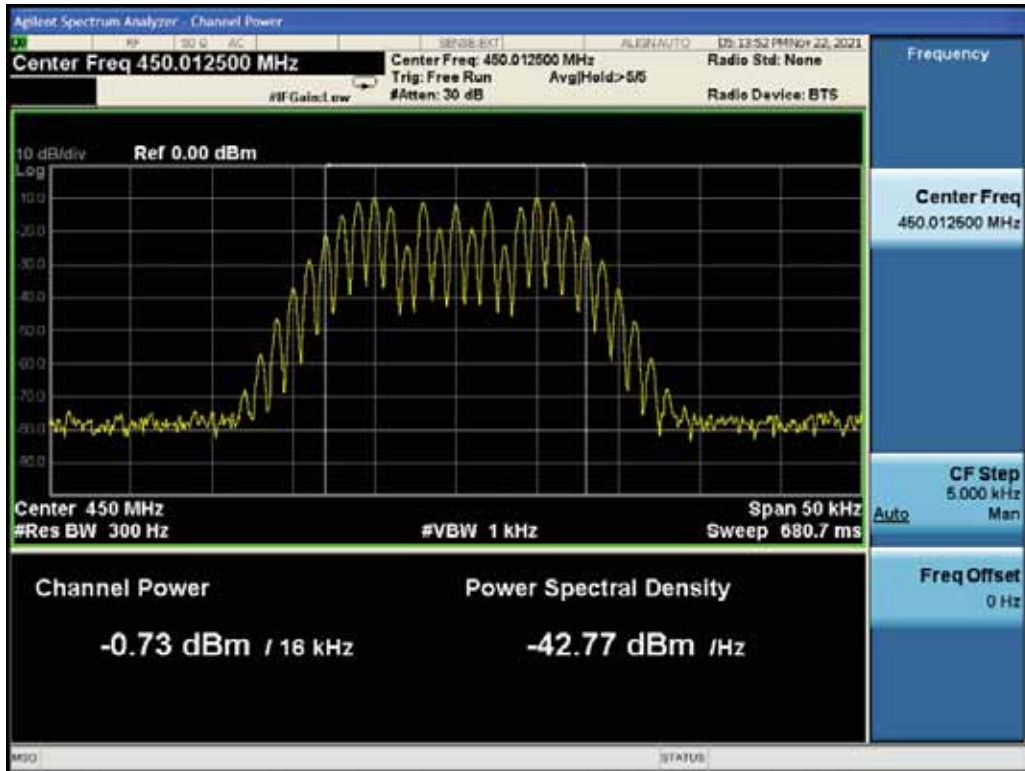

Low Frequency: 450.0125MHz

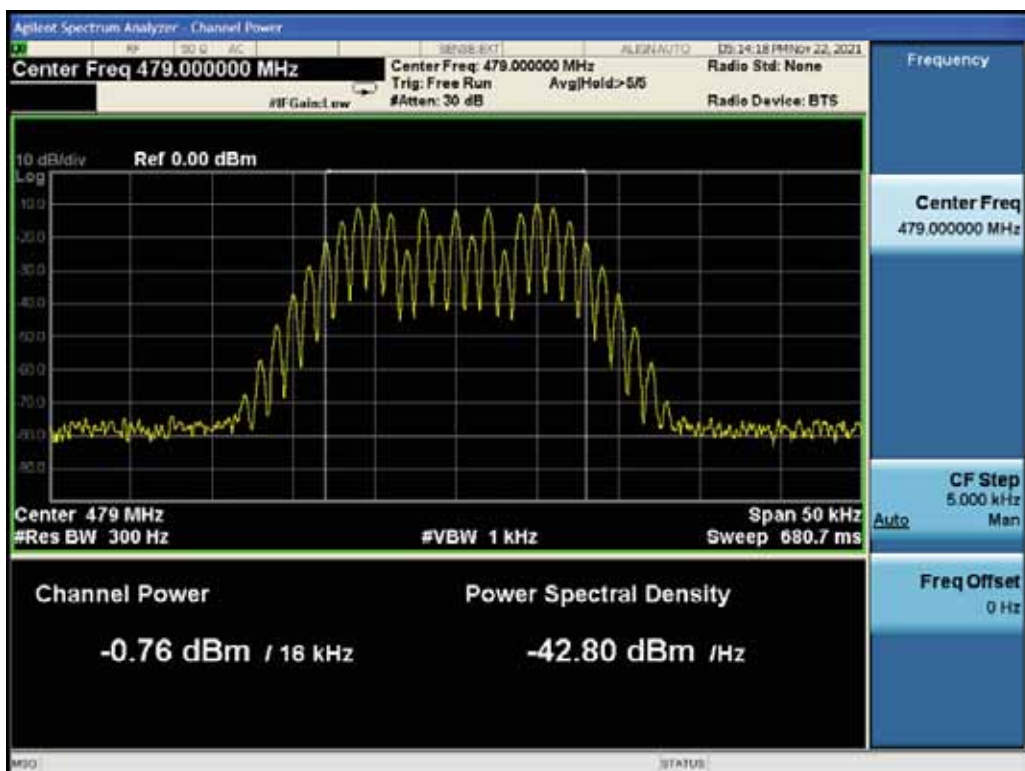

Middle Frequency: 479.0MHz

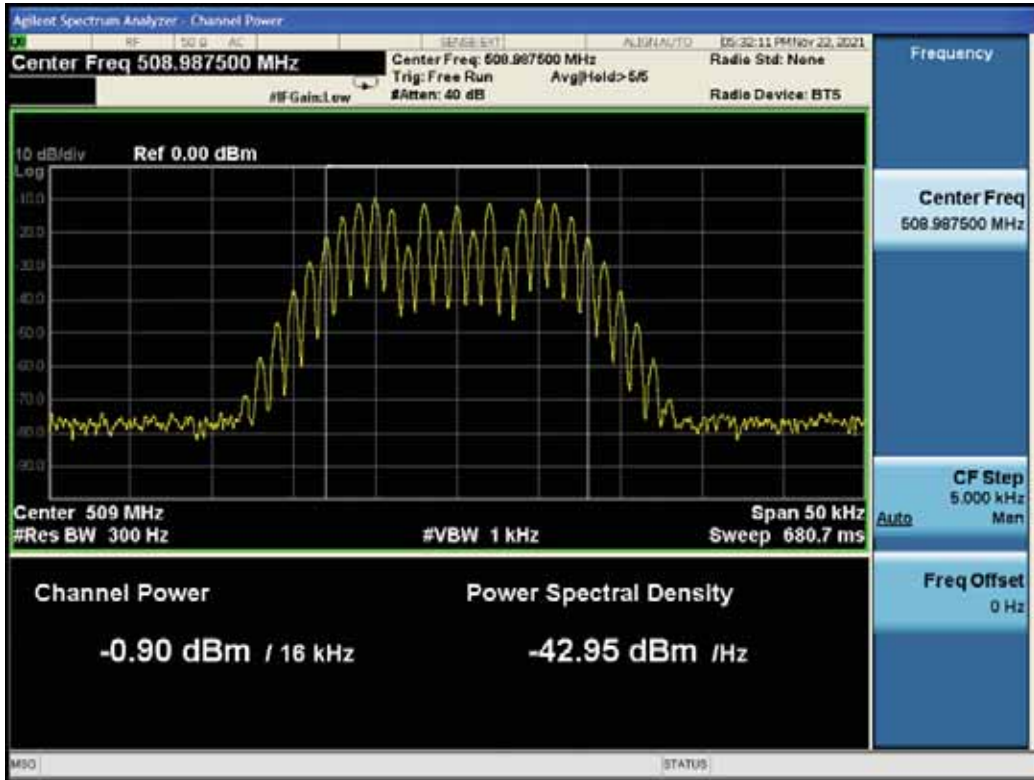

High Frequency: 508.9875MHz

10.2.3.5.2. Uplink

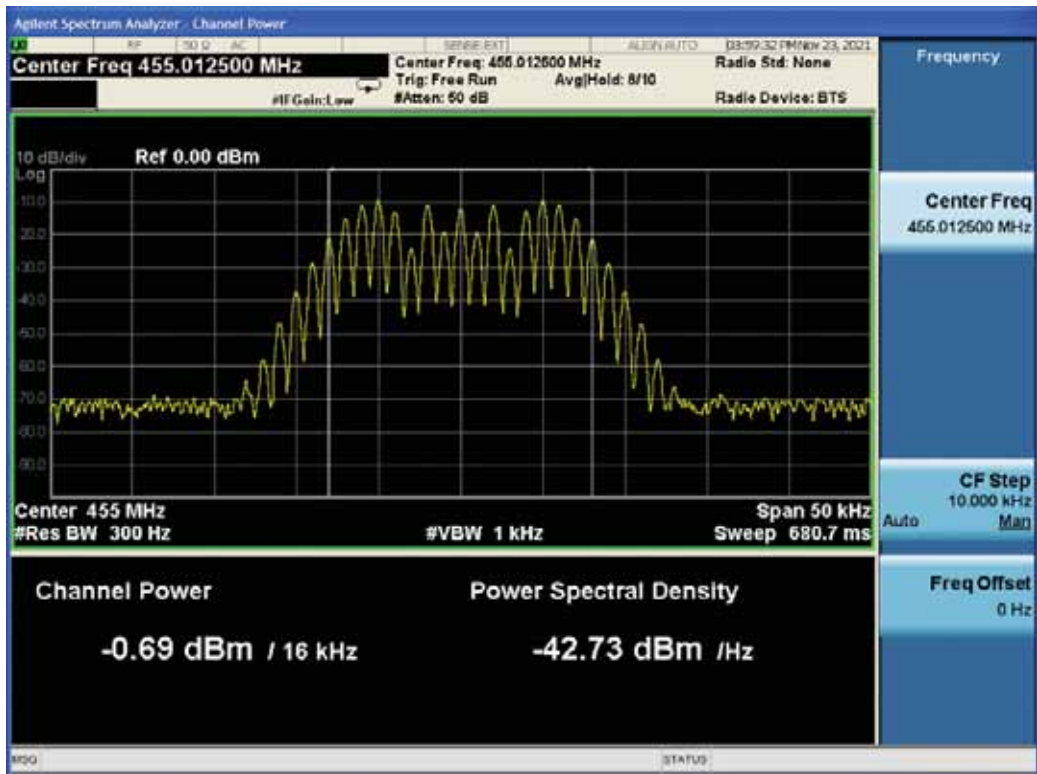

Low Frequency: 455.0125MHz

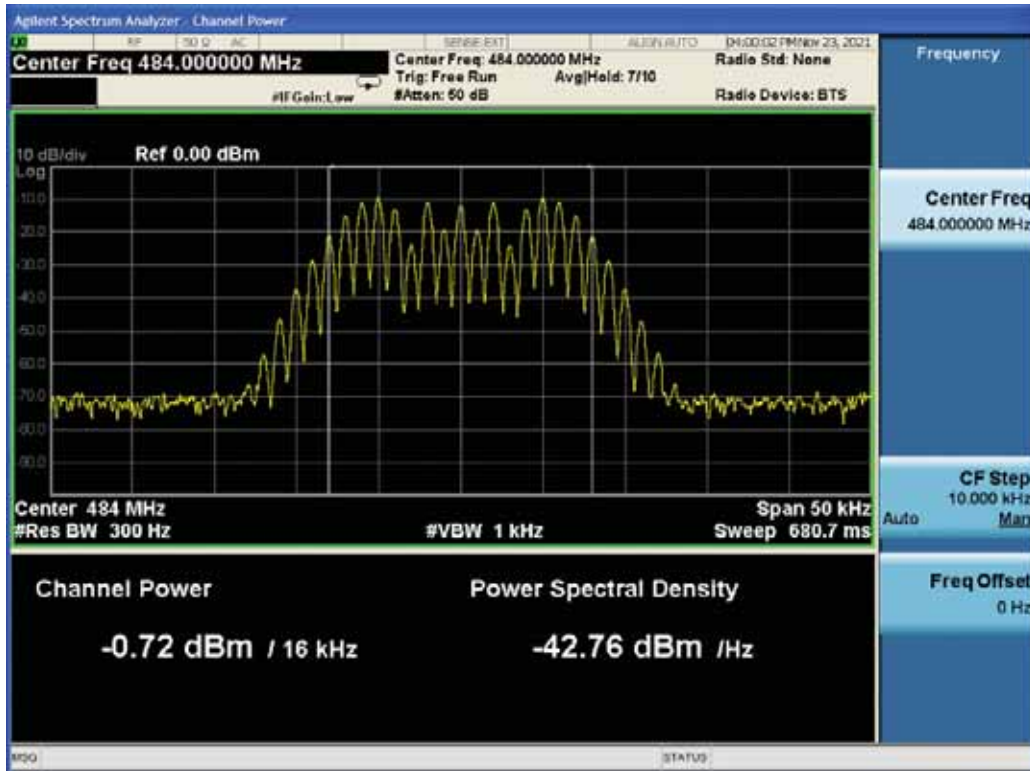

Middle Frequency: 484.0MHz

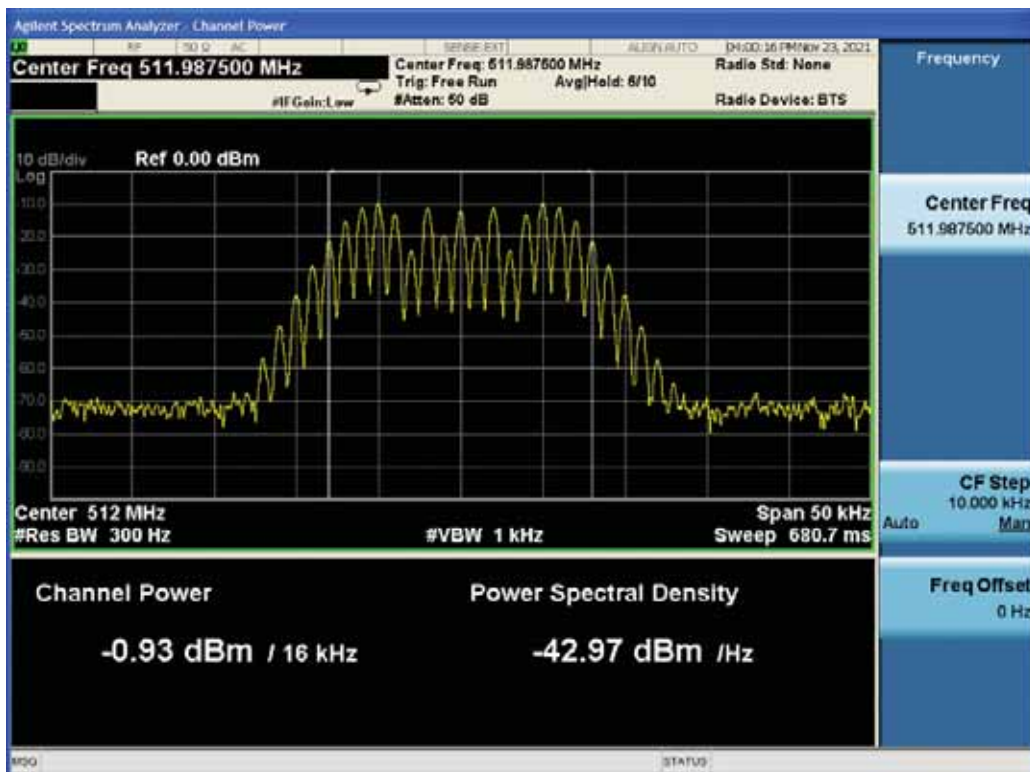

High Frequency: 511.9875MHz

10.3. AGC Threshold

Requirements: KDB 935210 D05 clause 4.2

Test Method: KDB 935210 D05 clause 3.2

10.3.1. Requirements

Testing at and above the AGC threshold will be required.⁶ The AGC threshold shall be determined by applying the procedure of 3.2, but with the signal generator configured to produce a test signal defined in Table 1, a CW input signal, or a digitally modulated signal, consistent with the discussion about signal types in 4.1.

10.3.2. Test configuration

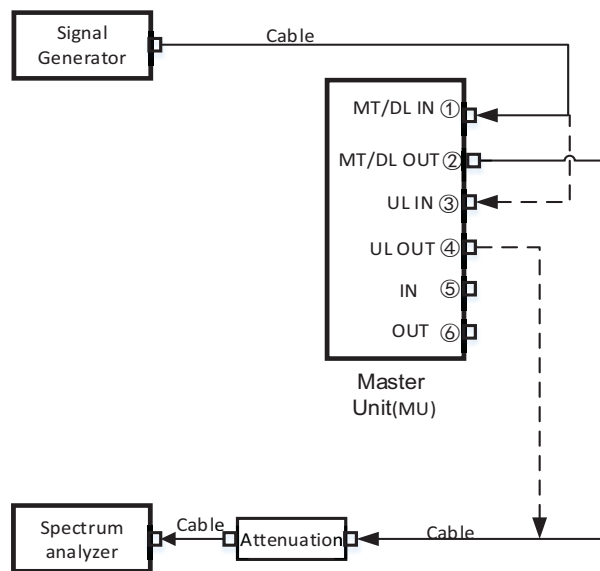

Figure 10.3-1 MU single device test connection diagram

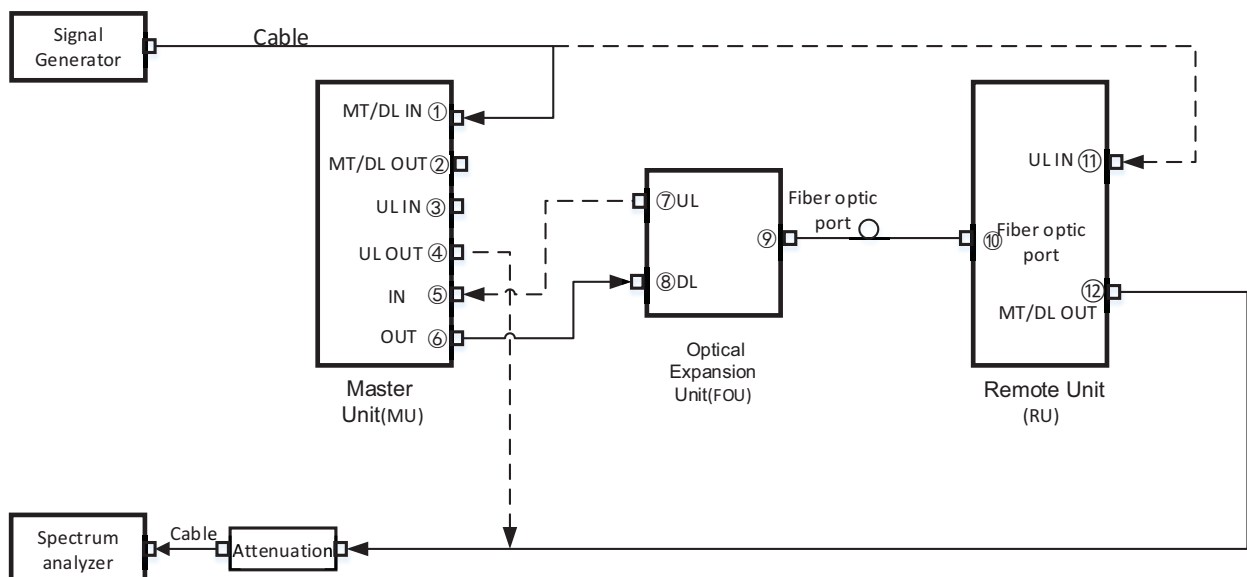

Figure 10.3-2 MU, FOU and RU system test connection diagram

10.3.3. Test procedures

3.2 Measuring AGC threshold level

The AGC threshold is to be determined as follows.³

In the case of fiber-optic distribution systems, the RF input port of the equipment under test (EUT) refers to the RF input of the supporting equipment RF to optical convertor; see also descriptions and diagrams for typical DAS booster systems in KDB Publication 935210 D02 [R7].

Devices intended to be directly connected to an RF source (donor port) only need to be evaluated for any over-the-air transmit paths.

- a) Connect a signal generator to the input of the EUT.
- b) Connect a spectrum analyzer or power meter to the output of the EUT using appropriate attenuation as necessary.
- c) The signal generator should initially be configured to produce either of the required test signals (i.e., broadband or narrowband).
- d) Set the signal generator frequency to the center frequency of the EUT operating band.
- e) While monitoring the output power of the EUT, measured using the methods of 3.5.3 or 3.5.4, increase the input level until a 1 dB increase in the input signal power no longer causes a 1 dB increase in the output signal power.
- f) Record this level as the AGC threshold level.
- g) Repeat the procedure with the remaining test signal.

----- The following blanks -----

10.3.4. Test results

Test Date (yy-mm-dd): 2021-11-22

Normal condition: Temp: 25.5°C, Humid: 44%, Atmospheric Pressure:101kpa

Supply Voltage: DC -48V

10.3.4.1.MU single device test

10.3.4.1.1. Downlink

Test frequency	Signal output power (dBm)	EUT Input cable loss (dB)	EUT Corrected Input power (dBm)	EUT Corrected Output power (dBm)
Downlink 479.0MHz	-74.0	1.1	-75.1	30.9
	-73.0	1.1	-74.1	31.9
	-72.0	1.1	-73.1	32.9
	-71.0	1.1	-72.1	33.9
	-70.0	1.1	-71.1	35.0
	-69.0	1.1	-70.1	36.0
	-68.0	1.1	-69.1	36.0
	-67.0	1.1	-68.1	36.0
	-66.0	1.1	-67.1	36.0
	-65.0	1.1	-66.1	36.0
	-64.0	1.1	-65.1	36.0

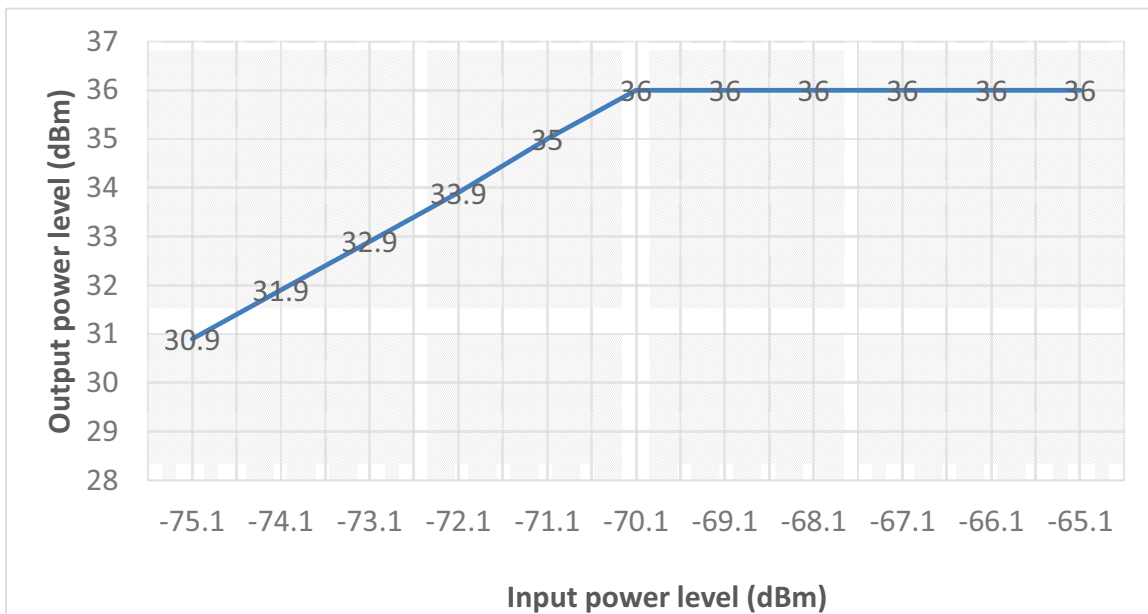

10.3.4.1.2. Uplink

Test frequency	Signal output power (dBm)	EUT Input cable loss (dB)	EUT Corrected Input power (dBm)	EUT Corrected Output power (dBm)
Uplink 484.0MHz	-77.0	1.1	-78.1	24.1
	-76.0	1.1	-77.1	25.1
	-75.0	1.1	-76.1	26.1
	-74.0	1.1	-75.1	27.1
	-73.0	1.1	-74.1	28.2
	-72.0	1.1	-73.1	29.2
	-71.0	1.1	-72.1	29.2
	-70.0	1.1	-71.1	29.2
	-69.0	1.1	-70.1	29.2
	-68.0	1.1	-69.1	29.2
	-67.0	1.1	-68.1	29.2

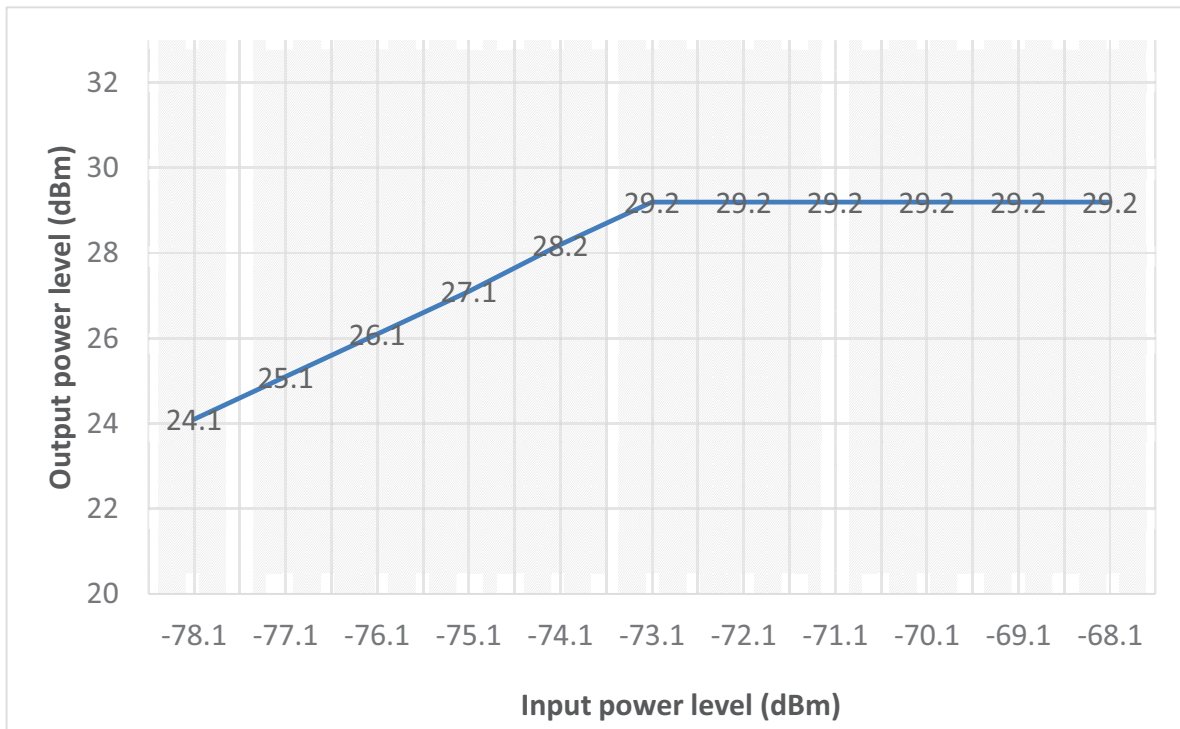

10.3.4.2. System test

10.3.4.2.1. Uplink

Test frequency	Signal output power (dBm)	EUT Input cable loss (dB)	EUT Corrected Input power (dBm)	EUT Corrected Output power (dBm)
Uplink 484.0MHz	-80.0	1.1	-81.1	24.1
	-79.0	1.1	-80.1	25.1
	-78.0	1.1	-79.1	26.1
	-77.0	1.1	-78.1	27.1
	-76.0	1.1	-77.1	28.2
	-75.0	1.1	-76.1	29.2
	-74.0	1.1	-75.1	29.2
	-73.0	1.1	-74.1	29.2
	-72.0	1.1	-73.1	29.2
	-71.0	1.1	-72.1	29.2
	-70.0	1.1	-71.1	29.2

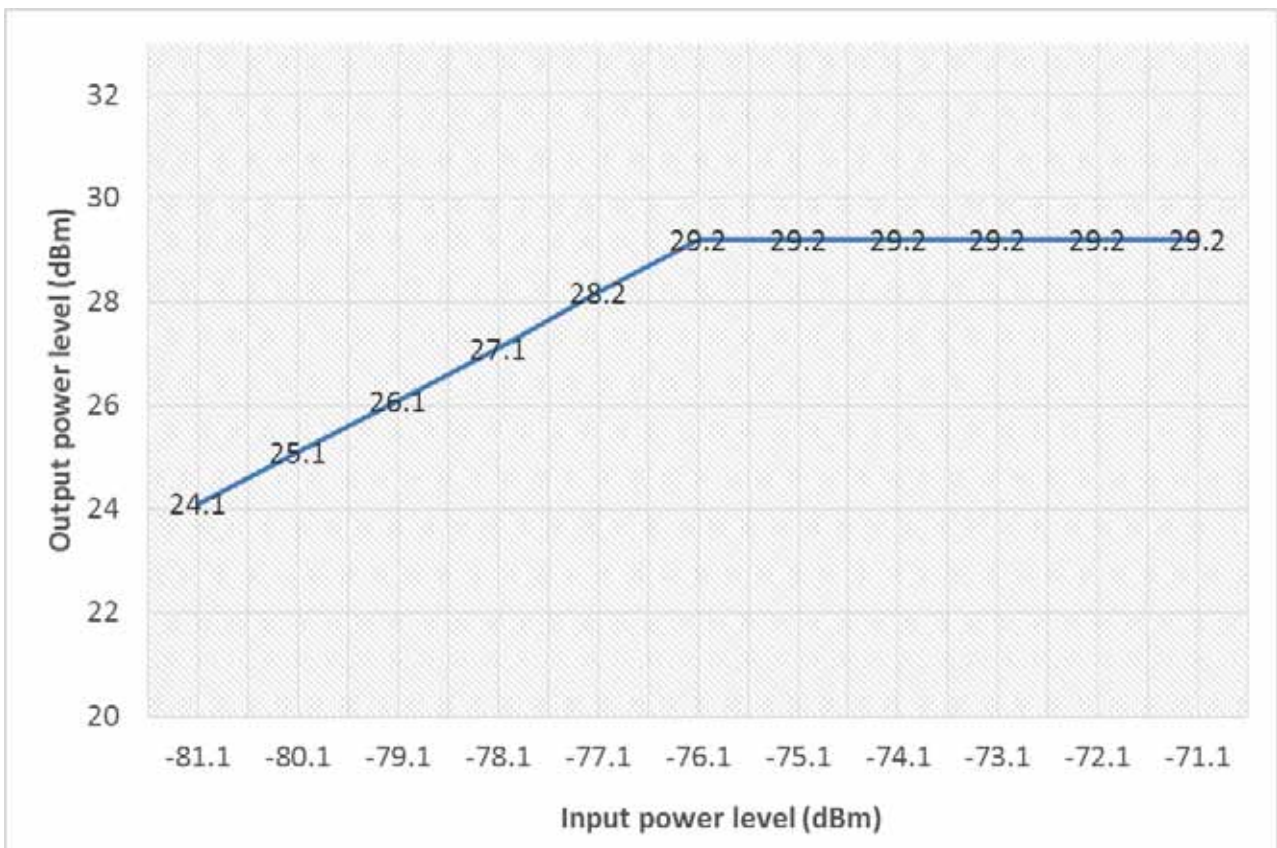

10.4. Out-of-band rejection

Test requirement: KDB 935210 D05 clause 4.3
 FCC PART 90.219 (a)
 FCC PART 90.219 (d)((7))

Test Method: KDB 935210 D05 clause 4.3

10.4.1. Requirements

According to KDB 935210 D05 clause 4.3 requirement, a signal booster shall reject amplification of other signals outside of its passband. Adjust the internal gain control of the EUT to the maximum gain for which equipment certification is sought.

10.4.2. Test configuration

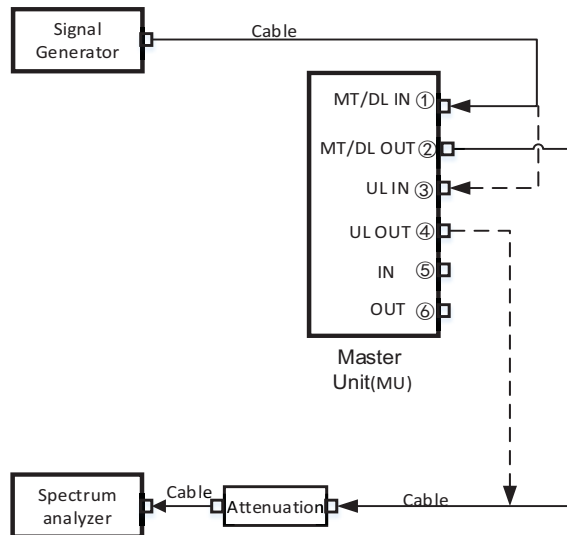

Figure 10.4-1 MU single device test connection diagram

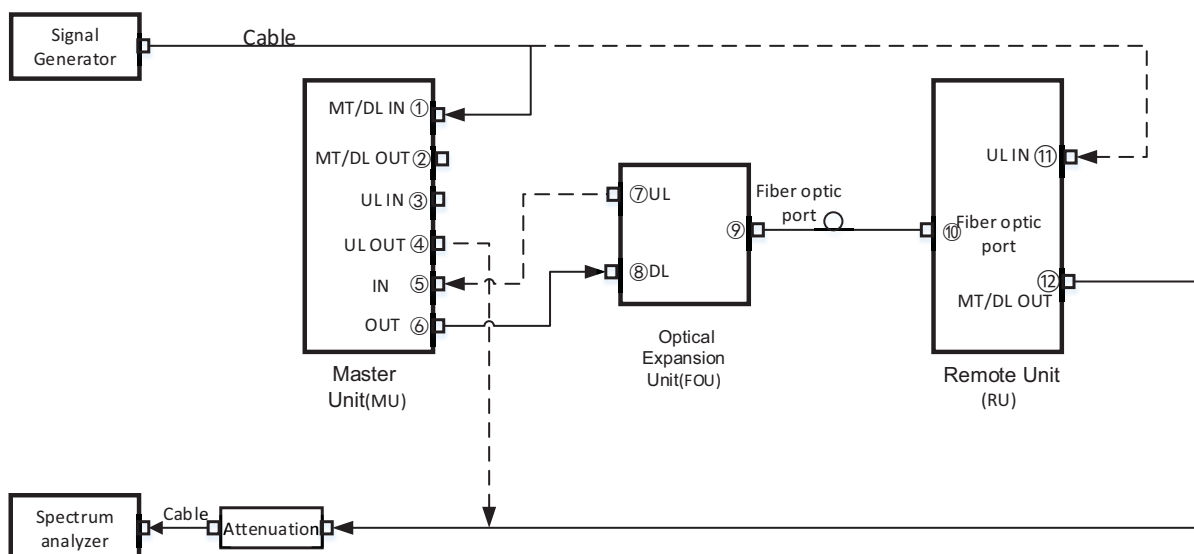

Figure 10.4-2 MU, FOU and RU system test connection diagram

10.4.3. Test procedures

- a) Connect a signal generator to the input of the EUT.
- b) Configure a swept CW signal with the following parameters:
 - 1) Frequency range = ± 250 % of the manufacturer's specified pass band.
 - 2) The CW amplitude shall be 3 dB below the AGC threshold (see 4.2), and shall not activate the AGC threshold throughout the test.
 - 3) Dwell time = approximately 10 ms.
 - 4) Frequency step = 50 kHz.
- c) Connect a spectrum analyzer to the output of the EUT using appropriate attenuation.
- d) Set the RBW of the spectrum analyzer to between 1 % and 5 % of the manufacturer's rated passband, and $VBW = 3 \times RBW$.
- e) Set the detector to Peak and the trace to Max-Hold.
- f) After the trace is completely filled, place a marker at the peak amplitude, which is designated as f_0 , and with two additional markers (use the marker-delta method) at the 20 dB bandwidth (i.e., at the points where the level has fallen by 20 dB).
- g) Capture the frequency response plot for inclusion in the test report.

----- The following blanks -----

10.4.4. Test results

Test Date (yy-mm-dd): 2021-11-23~11-24

Normal condition: Temp: 25.7~26.5°C, Humid:41~42%, Atmospheric Pressure:101kpa

Supply Voltage: DC -48V

10.4.4.1.MU single device test

RBW (kHz)	VBW (kHz)	Peak frequency (MHz)	Peak power (dBm)	20dB BW (MHz)
(1) Downlink				
1000	3000	484.0	36.46	61.4
(2) Uplink				
1000	3000	479.2	26.92	62.3

10.4.4.2.System test

RBW (kHz)	VBW (kHz)	Peak frequency (MHz)	Peak power (dBm)	20dB BW (MHz)
(3) Uplink				
1000	3000	497.0	29.49	60.8

10.4.5. Test screenshot

10.4.5.1. MU single device test

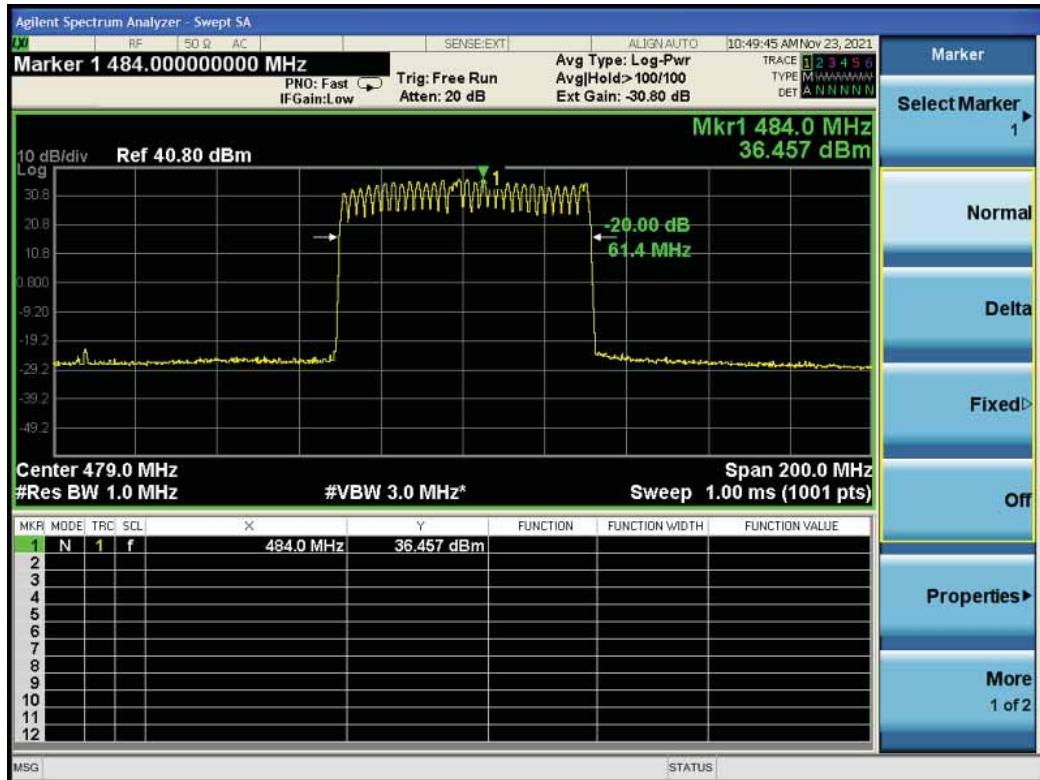

Downlink:



Uplink

10.4.5.2. System test

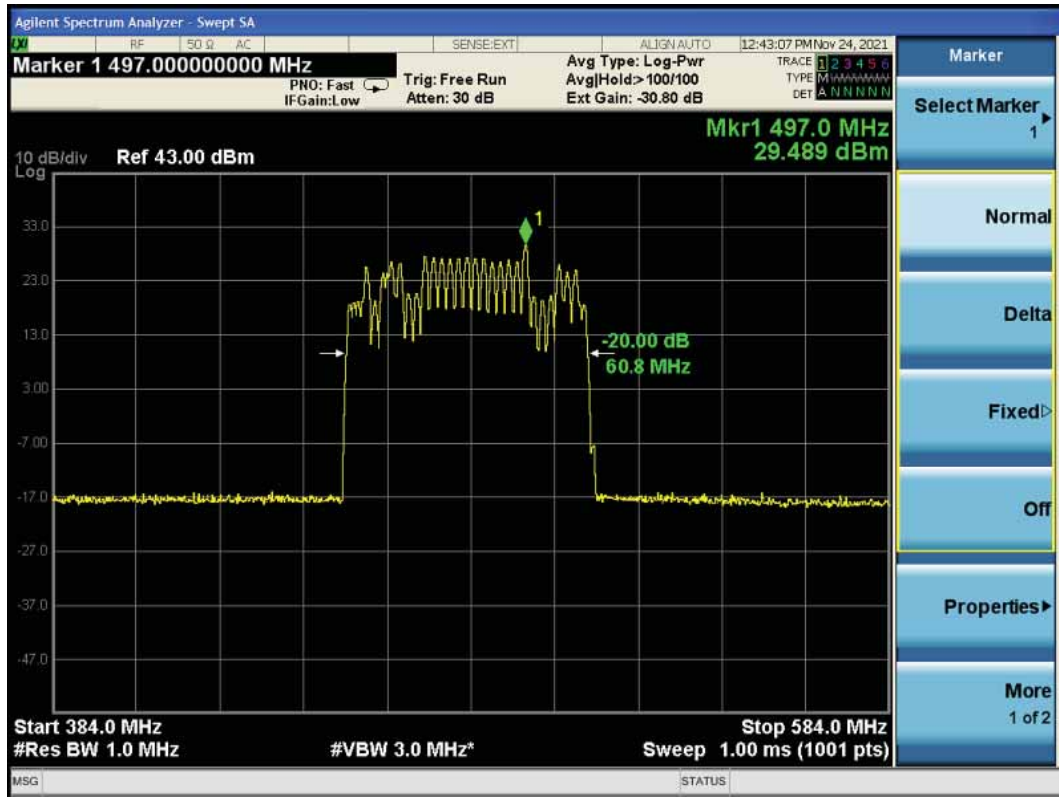

Uplink

----- The following blanks -----

10.5. Input VS output Comparison

Test requirement: KDB 935210 D05 clause 4.4
FCC PART 2.1049(c)
FCC PART 90.219 (e)(4)(ii)
FCC PART 90.219 (e)(4)(iii)

Test Method: KDB 935210 D05 clause 4.4

10.5.1. Requirements

10.5.1.1. Emission mask

According to KDB 935210 D05 clause 4.4 requirement:

4.4 Input-versus-output signal comparison

Compliance with the emission mask of the EUT output shall be measured for the public safety service signal types as specified in 4.1.

According to the characteristics of the product and FCC PART 90.210 requirement, clause (b), clause (c), clause (d) and clause (e) in FCC PART 90.210 are used, except as indicated else where in this part, transmitters used in the radio services governed by this part must comply with the emission masks outlined in this section. measurements of emission power can be expressed in either peak or average values provided that emission powers are expressed with the same parameters used to specify the unmodulated transmitter carrier power. For transmitters that do not produce a full power unmodulated carrier, reference to the unmodulated transmitter carrier power refers to the total power contained in the channel bandwidth. Unless indicated elsewhere in this part, the table in this section specifies the emission masks for device operating under this part.

§90.210 Emission masks.

Except as indicated elsewhere in this part, transmitters used in the radio services governed by this part must comply with the emission masks outlined in this section. Unless otherwise stated, per paragraphs (d)(4), (e)(4), and (o) of this section, measurements of emission power can be expressed in either peak or average values provided that emission powers are expressed with the same parameters used to specify the unmodulated transmitter carrier power. For transmitters that do not produce a full power unmodulated carrier, reference to the unmodulated transmitter carrier power refers to the total power contained in the channel bandwidth. Unless indicated elsewhere in this part, the table in this section specifies the emission masks for equipment operating under this part.

APPLICABLE EMISSION MASKS

Frequency band (MHz)	Mask for equipment with audio low pass filter	Mask for equipment without audio low pass filter
Below 25 ¹	A or B	A or C
25-50	B	C
72-76	B	C
150-174 ²	B, D, or E	C, D or E
150 paging only	B	C
220-222	F	F
421-512 ^{2 5}	B, D, or E	C, D, or E
450 paging only	B	G
806-809/851-854 ⁶	B	H
809-824/854-869 ³⁵	B, D	D, G.
896-901/935-940	I	J
902-928	K	K
929-930	B	G
4940-4990 MHz	L or M	L or M
5850-5925 ⁴		
All other bands	B	C

NOTE: Emission Mask B and Mask C –25 kHz channel;

Emission Mask D—12.5 kHz channel;

Emission Mask E—6.25kHz;

1.1.1.1.1 Emission Mask B

(b) *Emission Mask B.* For transmitters that are equipped with an audio low-pass filter, the power of any emission must be attenuated below the unmodulated carrier power (P) as follows:

(1) On any frequency removed from the assigned frequency by more than 50 percent, but not more than 100 percent of the authorized bandwidth: At least 25 dB.

(2) On any frequency removed from the assigned frequency by more than 100 percent, but not more than 250 percent of the authorized bandwidth: At least 35 dB.

(3) On any frequency removed from the assigned frequency by more than 250 percent of the authorized bandwidth: At least 43 + 10 log (P) dB.

(c) *Emission Mask C.* For transmitters that are not equipped with an audio low-pass filter, the power of any emission must be attenuated below the unmodulated carrier output power (P) as follows:

----- The following blanks -----

1.1.1.1.2 Emission Mask C

(c) *Emission Mask C*. For transmitters that are not equipped with an audio low-pass filter, the power of any emission must be attenuated below the unmodulated carrier output power (P) as follows:

(1) On any frequency removed from the center of the authorized bandwidth by a displacement frequency (f_d in kHz) of more than 5 kHz, but not more than 10 kHz: At least $83 \log (f_d/5)$ dB;

(2) On any frequency removed from the center of the authorized bandwidth by a displacement frequency (f_d in kHz) of more than 10 kHz, but not more than 250 percent of the authorized bandwidth: At least $29 \log (f_d^2/11)$ dB or 50 dB, whichever is the lesser attenuation;

(3) On any frequency removed from the center of the authorized bandwidth by more than 250 percent of the authorized bandwidth: At least $43 + 10 \log (P)$ dB.

1.1.1.1.3 Emission Mask D

(d) *Emission Mask D—12.5 kHz channel bandwidth equipment*. For transmitters designed to operate with a 12.5 kHz channel bandwidth, any emission must be attenuated below the power (P) of the highest emission contained within the authorized bandwidth as follows:

(1) On any frequency from the center of the authorized bandwidth f_0 to 5.625 kHz removed from f_0 : Zero dB.

(2) On any frequency removed from the center of the authorized bandwidth by a displacement frequency (f_d in kHz) of more than 5.625 kHz but no more than 12.5 kHz: At least $7.27(f_d - 2.88 \text{ kHz})$ dB.

(3) On any frequency removed from the center of the authorized bandwidth by a displacement frequency (f_d in kHz) of more than 12.5 kHz: At least $50 + 10 \log (P)$ dB or 70 dB, whichever is the lesser attenuation.

(4) The reference level for showing compliance with the emission mask shall be established using a resolution bandwidth sufficiently wide (usually two or three times the channel bandwidth) to capture the true peak emission of the equipment under test. In order to show compliance with the emission mask up to and including 50 kHz removed from the edge of the authorized bandwidth, adjust the resolution bandwidth to 100 Hz with the measuring instrument in a peak hold mode. A sufficient number of sweeps must be measured to insure that the emission profile is developed. If video filtering is used, its bandwidth must not be less than the instrument resolution bandwidth. For emissions beyond 50 kHz from the edge of the authorized bandwidth, see paragraph (o) of this section. If it can be shown that use of the above instrumentation settings do not accurately represent the true interference potential of the equipment under test, an alternate procedure may be used provided prior Commission approval is obtained.