

6.4.4.2 800MHz Band

6.4.4.2.1 Modulation signal: C4FM, Tetra and Analog FM

Frequency range		Max. Spurious Limit(dBm)	RBW (kHz)	Max. Spurious mark Level (dBm)	Margin ^{1*} (dB)	Result
1). AC 120V, 50/60Hz						
1.1) Downlink transmit mode (Frequency range: 851MHz~862MHz)						
Low frequency 851.0125MHz	9kHz~1GHz	-13	100	-56.01	-43.01	pass
	1GHz~8.6GHz	-13	100	-49.19	-36.19	pass
Mid frequency 856.5125MHz	9kHz~1GHz	-13	100	-55.48	-42.48	pass
	1GHz~8.6GHz	-13	100	-49.21	-36.21	pass
High frequency 861.9875MHz	9kHz~1GHz	-13	100	-54.29	-41.29	pass
	1GHz~8.6GHz	-13	100	-50.58	-37.58	pass
1.2) Uplink transmit mode(Frequency range: 806MHz~817MHz)						
Low frequency 806.0125MHz	9kHz~1GHz	-13	100	-48.84	-3.84	pass
	1GHz~8.6GHz	-13	100	-51.94	-38.94	pass
Mid frequency 811.5125MHz	9kHz~1GHz	-13	100	-48.59	-35.59	pass
	1GHz~8.6GHz	-13	100	-51.19	-38.19	pass
High frequency 817.9875MHz	9kHz~1GHz	-13	100	-48.30	-35.30	pass
	1GHz~8.6GHz	-13	100	-54.18	-38.18	pass
2. DC -48V						
2.1) Downlink transmit mode (Frequency range: 851MHz~862MHz)						
Low frequency 851.0125MHz	9kHz~1GHz	-13	100	-56.01	-43.01	pass
	1GHz~8.6GHz	-13	100	-49.19	-36.19	pass
Mid frequency 856.5125MHz	9kHz~1GHz	-13	100	-55.48	-42.48	pass
	1GHz~8.6GHz	-13	100	-49.21	-36.21	pass
High frequency 861.9875MHz	9kHz~1GHz	-13	100	-54.29	-41.29	pass
	1GHz~8.6GHz	-13	100	-50.58	-37.58	pass
2.2) Uplink transmit mode(Frequency range: 806MHz~817MHz)						
Low frequency 806.0125MHz	9kHz~1GHz	-13	100	-51.04	-38.04	pass

	1GHz~8.6GHz	-13	100	-59.71	-46.71	pass
Mid frequency 811.5125MHz	9kHz~1GHz	-13	100	-50.12	-37.12	pass
	1GHz~8.6GHz	-13	100	-59.89	-46.89	pass
High frequency 817.9875MHz	9kHz~1GHz	-13	100	-49.26	-36.26	pass
	1GHz~8.6GHz	-13	100	-59.35	-46.35	pass
Note: 1*--Margin= Maximum mark level- specification limit.						

6.5 Frequency stability

Test Date (yy-mm-dd): 2017-05-16 to 2017-07-11

Test environment: Normal

Ambient Temp 24.1°C~26.1°C, Humid 46%~51%, Atmospheric Pressure 101kpa

Power supply: AC 120V 50/60Hz

Test Method: KDB 935210 D05 Indus Booster Basic Meas v01r01

Test Requirement: FCC part 90.213 & part 90.539

6.5.1 Limit

Unless noted elsewhere, transmitters used in the services governed by this part must have a minimum frequency stability as specified in the following table 9.

Table 9 Frequency stability limits

frequency range(MHz)	Minimum Frequency Stability(ppm)
758-768/788~798	± 2.5
769-775/799-805	± 1.5(Channel Bandwidth 12.5kHz) ± 2.5(Channel Bandwidth 25kHz)
806-809/851-854	± 1.0
809-817/854-862	± 1.5

6.5.2 Test configuration

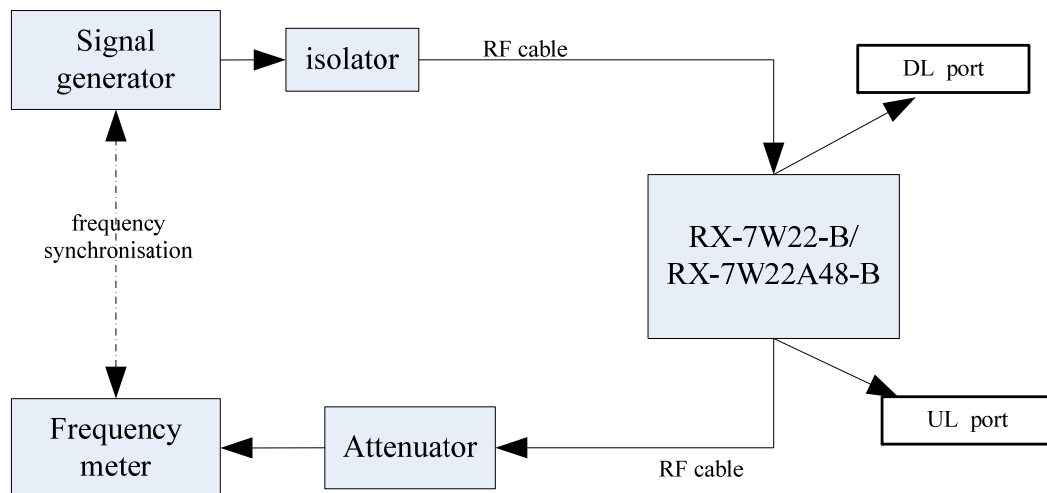

Figure 9: Frequency stability arrangement for Downlink

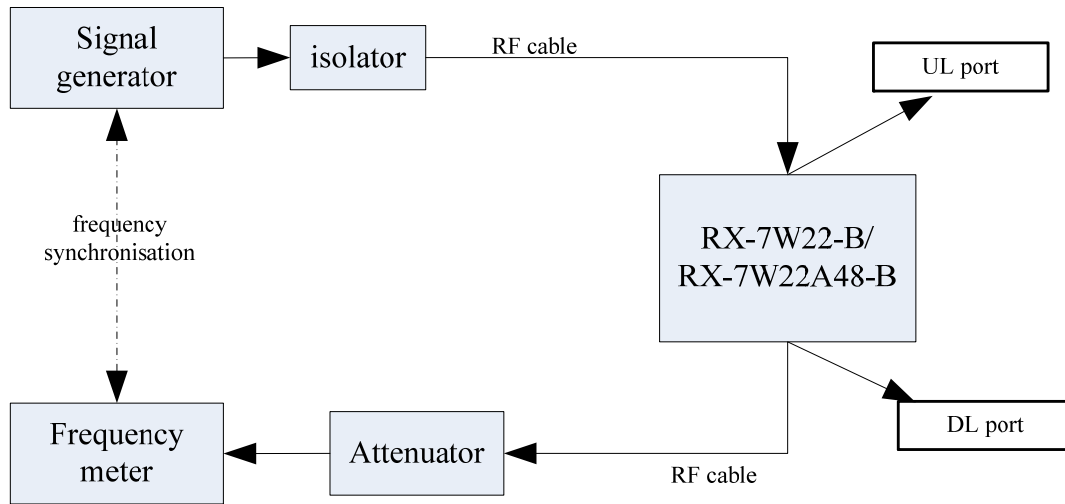

Figure 10: Frequency stability arrangement for Uplink

6.5.3 Test procedures

- (1) Connect the device as illustrated Figure 9 and Figure 10, when the output power is over the maximum value of the Spectrum Analyzer, add the attenuator to avoid destroying;
- (2) The signal generator should initially be configured to produce CW signals;
- (3) Set the signal generator frequency to the center frequency of the EUT operating band;
- (4) Keep signal source and frequency meter synchronization;
- (5) Record Output frequency value when level as the ALC threshold level;
- (6) Read the frequency at the relative temperature;
- (7) Vary the voltage from -15% nominal voltage to +15% voltage;

6.5.4 Test Results

6.5.4.1 700MHz Band

Voltage	Input carrier frequency(MHz)	Output carrier frequency(MHz)	Limit(ppm)	Frequency stability(ppm)	Result
1). Downlink Frequency range: 758MHz~768MHz					
AC 102V(120*85%)	763.0	763.0	±2.5	0	pass
AC 120V	763.0	763.0	±2.5	0	pass
AC 138V(120*115%)	763.0	763.0	±2.5	0	pass
Frequency range: 769MHz~775MHz					
AC 102V(120*85%)	772.0125	772.012499	±1.5	-0.0013	pass
AC 120V	772.0125	772.012499	±1.5	-0.0013	pass
AC 138V(120*115%)	772.0125	772.012499	±1.5	-0.0013	pass
2). Uplink Frequency range: 788MHz~798MHz					
AC 102V(120*85%)	793.0	792.999999	±2.5	-0.0013	pass
AC 120V	793.0	792.999999	±2.5	-0.0013	pass
AC 138V(120*115%)	793.0	792.999999	±2.5	-0.0013	pass
Frequency range: 799MHz~805MHz					
AC 102V(120*85%)	802.0125	802.012501	±1.5	-0.0012	pass
AC 120V	802.0125	802.012501	±1.5	-0.0012	pass
AC 138V(120*115%)	802.0125	802.012501	±1.5	-0.0012	pass

6.5.4.2 800MHz Band

Voltage	Input carrier frequency(MHz)	Output carrier frequency(MHz)	Limit(ppm)	Frequency stability(ppm)	Result
1). Downlink Frequency range: 851MHz~862MHz					
AC 102V(120*85%)	856.5125	856.512502	±1.0	+0.0023	pass
AC 120V	856.5125	856.512502	±1.0	+0.0023	pass
AC 138V(120*115%)	856.5125	856.512502	±1.0	+0.0023	pass
2). Uplink Frequency range: 806MHz~817MHz					
AC 102V(120*85%)	811.5125	811.512499	±1.0	-0.0012	pass
AC 120V	811.5125	811.512499	±1.0	-0.0012	pass
AC 138V(120*115%)	811.5125	811.512499	±1.0	-0.0012	pass

6.5.5 Test screenshot

6.5.5.1 700MHz Band



Mid Frequency: 763.0MHz



Mid Frequency: 772.0125MHz



Mid Frequency: 793.0MHz



Mid Frequency: 802.0125MHz

6.5.5.2 800MHz Band



Downlink Frequency: 856.5125MHz



Uplink Frequency: 811.5125MHz

6.6 Noise figure

Test Date (yy-mm-dd): 2017-05-16 to 2017-05-19

Test environment: Normal

Ambient Temp 24.1°C~26.1°C, Humid 46%~51%, Atmospheric Pressure 101kpa

Power supply: AC 120V 50/60Hz

Test Method: KDB 935210 D05 Indus Booster Basic Meas v01r01

Test Requirement: FCC part 90.219(e2)

6.6.1 Limit

The noise figure limit of a signal booster must be given in table 10.

Table 10 Noise figure limits

frequency range(MHz)	Max. Noise figure limit(dB)
758-768/788~798	9
769-775/799-805	9
851-862/806-817	9

6.6.2 Test configuration

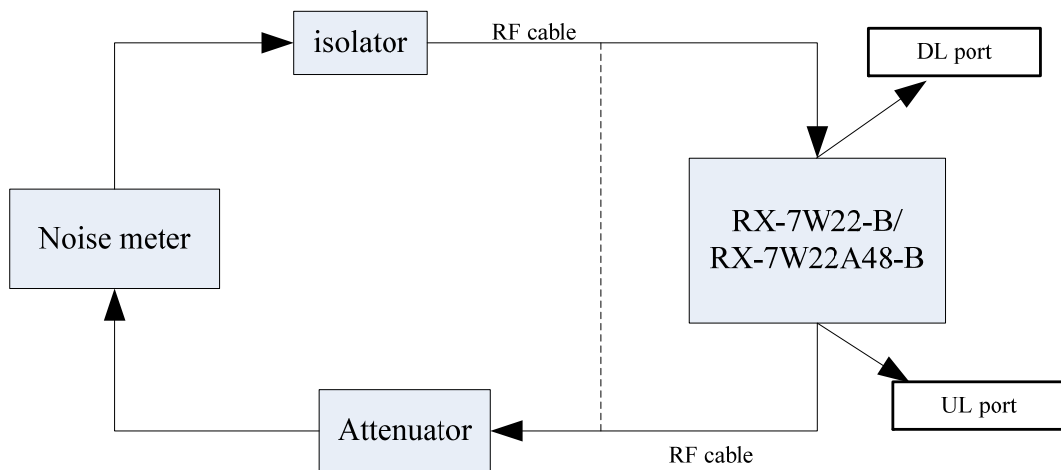

Figure 11: Noise figure arrangement for Downlink

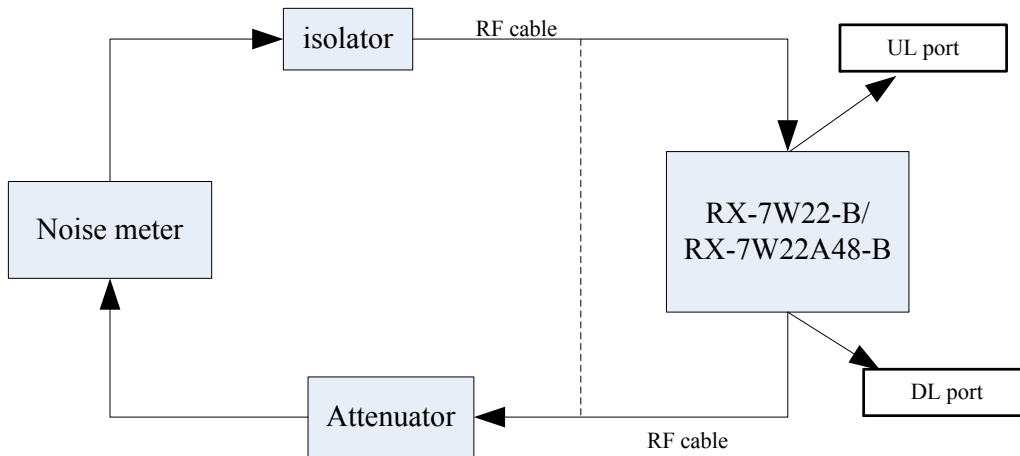

Figure 12: Noise figure arrangement for Uplink

6.6.3 Test procedures

- (1) Connect the device as illustrated Figure 11 and Figure 12, when the output power is over the maximum value of the Noise meter, add the attenuator to avoid destroying;
- (2) Set the signal generator frequency to the center frequency of the EUT operating band and maximum gain;
- (3) Set the relevant parameters for 700MHz of device and connect the dotted line to calibrate;
- (4) After calibrating , According to the solid line connecting and testing Noise figure and record data;
- (5) Repeat RF channels to be tested for 800MHz of device and Repeat steps (2) to (4);

6.6.4 Test Results

6.6.4.1 700MHz Band

Frequency(MHz)	Max.Limit(dB)	Noise figure data (dB)	Margin(dB)	Result
Downlink: 758~775	9	4.316	-4.684	pass
Uplink: 788~805	9	4.357	-4.643	pass

6.6.4.2 800MHz Band

Frequency(MHz)	Max.Limit(dB)	Noise figure data (dB)	Margin(dB)	Result
Downlink: 851~869	9	4.462	-4.538	pass
Uplink: 806~824	9	4.046	-4.954	pass

6.6.5 Test screenshot

6.6.5.1 700MHz Band



Downlink: 758MHz~776MHz



Uplink: 788MHz~806MHz

6.6.5.2 800MHz Band



Downlink: 851MHz~862MHz



Uplink: 806MHz~817MHz

6.7 Intermodulation product

Test Date (yy-mm-dd): 2017-05-16 to 2017-07-11

Test environment: Normal

Ambient Temp 24.1°C~26.1°C, Humid 46%~51%, Atmospheric Pressure 101kpa

Power supply: AC 120V 50/60Hz

Test Method: KDB 935210 D05 Indus Booster Basic Meas v01r01

Test Requirement: Part 90.219(e)(3)

6.7.1 Limit

Specification test limits of intermodulation products are given in table 11

Table 11 Intermodulation product limits

frequency range(MHz)	Max. intermodulation product limit(dBm)
758-768/788-798	-13.0
769-775/799-805	-13.0
806-817/851-862	-13.0

NOTE: RF channels to be tested for single-carrier: Low frequency, Mid frequency and High frequency;

6.7.2 Test configuration

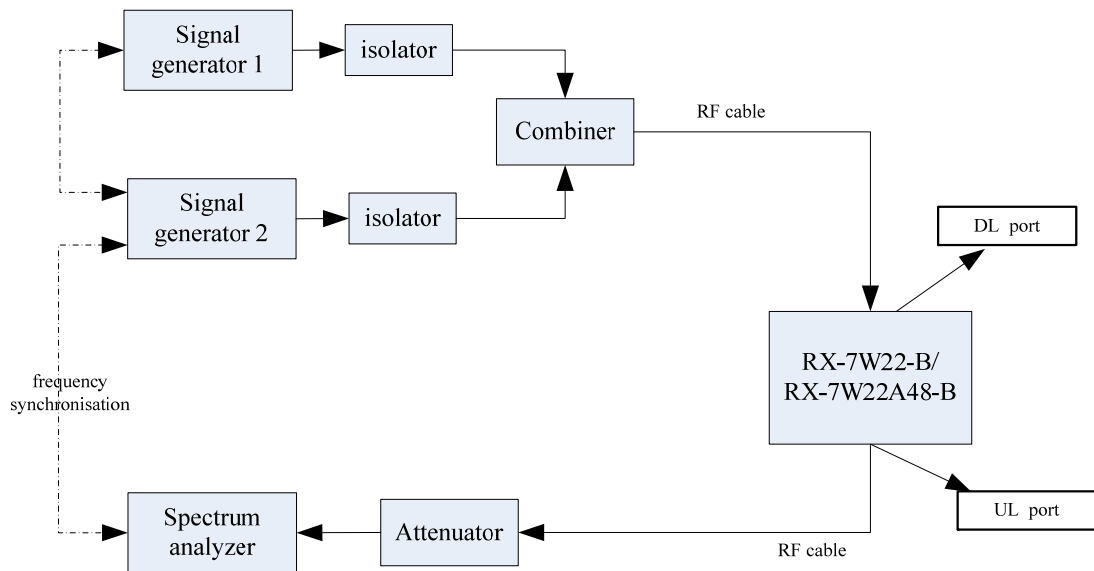

Figure 13: Conducted spurious emissions arrangement for Downlink

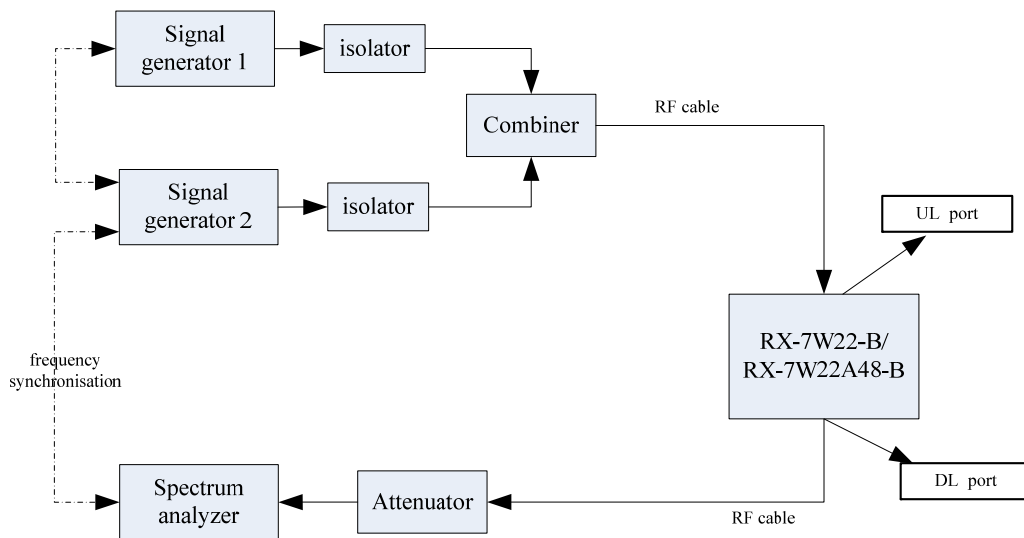

Figure 14: Conducted spurious emissions arrangement for Uplink

6.7.3 Test procedures

- (1) Connect the device as illustrated Figure 13 and Figure 14, when the output power is over the maximum value of the Spectrum Analyzer, add the attenuator to avoid destroying;
- (2) If the signal generator is not capable of producing two independent modulated carriers simultaneously, then two discrete signal generators can be connected, with an appropriate combining network to support the two-signal test;
- (3) Set the signal generator frequency to the center frequency of the EUT operating band;
- (4) Configure the two signal generator to produce CW on frequencies space consistent with 12.5kHz, 25kHz and 600kHz, with amplitude levels set to just below the ALC threshold and maximum gain;
- (5) Connect a spectrum analyzer to the EUT output;
- (6) Set the RBW = 1 kHz ;
- (7) Set the VBW = $3 \times$ RBW;
- (8) Set the detector to power averaging (rms);
- (9) Place a marker on highest intermodulation product amplitude;
- (10) Capture the plot for inclusion in the test report;
- (11) Repeat step (3) to (10) with the composite input power level set to 3 dB above the ALC threshold;
- (12) Repeat steps (2) to (11) for all operational bands;

6.7.4 Test Results

6.7.4.1 700MHz Band

(1) Downlink transmit mode

Frequency range	Intermodulation product Limit (dBm)	Max. intermodulation product (dBm)	Margin (dB)	Result	
1). Frequency range: 758MHz~768MHz					
1.1). With the ALC threshold level					
Low frequency: f1: 758.7MHz f2: 759.3MHz	-13	-14.63	-1.63	pass	
Mid frequency: f1: 762.7MHz f2: 763.3MHz	-13	-16.60	-3.60	pass	
High frequency: f1: 766.7MHz f2: 767.3MHz	-13	-15.14	-2.14	pass	
1.2). With the input signal amplitude set 3 dB above the ALC threshold					
Low frequency: f1: 758.7MHz f2: 759.3MHz	-13	-15.00	-2.00	pass	
Mid frequency: f1: 763.7MHz f2: 763.3MHz	-13	-17.33	-4.33	pass	
High frequency: f1: 766.7MHz f2: 767.3MHz	-13	-14.76	-1.76	pass	
2). Frequency range: 769MHz~775MHz					
2.1). With the ALC threshold level					
Channel Bandwidth: 12.5kHz	Low frequency: f1: 769.00625MHz f2: 769.01875MHz	-13	-17.52	-4.52	pass
	Mid frequency: f1: 772.0MHz f2: 772.0125MHz	-13	-17.36	-4.36	pass
	High frequency: f1: 774.98125MHz f2: 774.99375MHz	-13	-16.29	-3.29	pass
Channel Bandwidth: 25kHz	Low frequency: f1: 769.0125MHz f2: 769.0375MHz	-13	-16.63	-3.63	pass
	Mid frequency: f1: 772.0MHz f2: 772.025MHz	-13	-15.06	-2.06	pass
	High frequency: f1: 774.9625MHz f2: 774.9875MHz	-13	-14.95	-1.95	pass
2.2). With the input signal amplitude set 3 dB above the ALC threshold					
Channel Bandwidth: 12.5kHz	Low frequency: f1: 769.00625MHz f2: 769.01875MHz	-13	-18.18	-5.18	pass
	Mid frequency: f1: 772.0MHz f2: 772.0125MHz	-13	-18.04	-5.04	pass
	High frequency: f1: 769.00625MHz f2: 774.99375MHz	-13	-16.12	-3.12	pass

Channel Bandwidth: 25kHz	Low frequency: f1:769.0125MHz f2:769.0375MHz	-13	-14.18	-1.18	pass
	Mid frequency: f1:772.0MHz f2:772.025MHz	-13	-14.62	-1.62	pass
	High frequency: f1:774.9625MHz f2:774.9875MHz	-13	-14.71	-1.71	pass
Note: 1*--Margin= Maximum mark level- specification limit.					

(2) Uplink transmit mode

Frequency range	Intermodulation product Limit (dBm)	Max. intermodulation product (dBm)	Margin (dB)	Result	
1). Frequency range: 788MHz~798MHz					
1.1). With the ALC threshold level					
Low frequency: f1: 788.7MHz f2:789.3MHz	-13	-32.03	-19.03	pass	
Mid frequency: f1: 792.7MHz f2: 793.3MHz	-13	-32.03	-19.03	pass	
High frequency: f1: 796.7MHz f2:797.3MHz	-13	-33.35	-20.35	pass	
1.2). With the input signal amplitude set 3 dB above the ALC threshold					
Low frequency: f1: 788.7MHz f2:789.3MHz	-13	-32.43	-19.43	pass	
Mid frequency: f1: 792.7MHz f2: 793.3MHz	-13	-32.98	-19.98	pass	
High frequency: f1: 796.7MHz f2:797.3MHz	-13	-31.52	-18.52	pass	
2). Frequency range: 799MHz~805MHz					
2.1). With the ALC threshold level					
Channel Bandwidth: 12.5kHz	Low frequency: f1:799.00625MHz f2:799.01875MHz	-13	-32.55	-19.55	pass
	Mid frequency: f1:802.0MHz f2:802.0125MHz	-13	-29.23	-16.23	pass
	High frequency: f1:804.98125MHz f2:804.99375MHz	-13	-26.98	-13.98	pass
Channel Bandwidth: 25kHz	Low frequency: f1:799.0125MHz f2:799.0375MHz	-13	-33.93	-20.93	pass
	Mid frequency: f1:802.0MHz f2:802.025MHz	-13	-30.05	-17.05	pass
	High frequency: f1:804.9625MHz f2:804.9875MHz	-13	-28.01	-15.01	pass

2.2). With the input signal amplitude set 3 dB above the ALC threshold					
Channel Bandwidth: 12.5kHz	Low frequency: f1:799.00625MHz f2:799.01875MHz	-13	-29.85	-16.85	pass
	Mid frequency: f1:802.0MHz f2:802.0125MHz	-13	-27.56	-14.56	pass
	High frequency: f1:804.98125MHz f2:804.99375MHz	-13	-25.93	-12.93	pass
Channel Bandwidth: 25kHz	Low frequency: f1:799.0125MHz f2:799.0375MHz	-13	-30.35	-17.35	pass
	Mid frequency: f1:802.0MHz f2:802.025MHz	-13	-28.46	-15.46	pass
	High frequency: f1:804.9625MHz f2:804.9875MHz	-13	-26.60	-13.60	pass
Note: 1*--Margin= Maximum mark level- specification limit.					

6.7.4.2 800MHz Band

(1) Downlink transmit mode

Frequency range	Intermodulaiton product Limit (dBm)	Max. intermodulation product(dBm)	Margin(dB)	Result	
1). With the ALC threshold level					
Channel Bandwidth: 12.5kHz	Low frequency: f1:851.00625MHz f2:851.01875MHz	-13	-14.01	-1.01	pass
	Mid frequency: f1:856.50625MHz f2:856.51875MHz	-13	-15.00	-2.00	pass
	High frequency: f1:861.98125MHz f2:861.99375MHz	-13	-15.37	-2.37	pass
Channel Bandwidth: 25kHz	Low frequency: f1:851.0125MHz f2:851.0375MHz	-13	-16.11	-3.11	pass
	Mid frequency: f1:856.5125MHz f2:856.5375MHz	-13	-18.69	-5.69	pass
	High frequency: f1:861.9625MHz f2:861.9875MHz	-13	-17.64	-4.64	pass
2). With the input signal amplitude set 3 dB above the ALC threshold					
Channel Bandwidth: 12.5kHz	Low frequency: f1:851.00625MHz f2:851.01875MHz	-13	-14.37	-1.37	pass

	Mid frequency: f1:856.50625MHz f2:856.51875MHz	-13	-14.79	-1.79	pass
	High frequency: f1:861.98125MHz f2:861.99375MHz	-13	-15.89	-2.89	pass
Channel Bandwidth: 25kHz	Low frequency: f1:851.0125MHz f2:851.0375MHz	-13	-16.72	-3.72	pass
	Mid frequency: f1:856.5125MHz f2:856.5375MHz	-13	-16.93	-3.93	pass
	High frequency: f1:861.9625MHz f2:861.9875MHz	-13	-17.24	-4.24	pass
Note: 1*--Margin= Maximum mark level- specification limit.					

(2) Uplink transmit mode

Frequency range	Intermodulaiton product Limit (dBm)	Max. intermodulation product(dBm)	Margin(dB)	Result	
1). With the ALC threshold level					
Channel Bandwidth: 12.5kHz	Low frequency: f1:806.00625MHz f2:806.01875MHz	-13	-16.79	-3.79	pass
	Mid frequency: f1:811.50625MHz f2:811.51875MHz	-13	-16.70	-3.70	pass
	High frequency: f1:816.98125MHz f2:816.99375MHz	-13	-16.38	-3.38	pass
Channel Bandwidth: 25kHz	Low frequency: f1:806.0125MHz f2:806.0375MHz	-13	-16.09	-3.09	pass
	Mid frequency: f1:811.5125MHz f2:811.5375MHz	-13	-16.46	-3.46	pass
	High frequency: f1:816.9625MHz f2:816.9875MHz	-13	-16.52	-3.52	pass
2). With the input signal amplitude set 3 dB above the ALC threshold					
Channel Bandwidth: 12.5kHz	Low frequency: f1:806.00625MHz f2:806.01875MHz	-13	-16.75	-3.75	pass
	Mid frequency: f1:811.50625MHz f2:811.51875MHz	-13	-16.34	-3.34	pass

	High frequency: f1:816.98125MHz f2:816.99375MHz	-13	-16.25	-3.25	pass
Channel Bandwidth: 25kHz	Low frequency: f1:806.0125MHz f2:806.0375MHz	-13	-16.49	-3.49	pass
	Mid frequency: f1:811.5125MHz f2:811.5375MHz	-13	-16.15	-3.15	pass
	High frequency: f1:816.9625MHz f2:816.9875MHz	-13	-16.92	-3.92	pass

Note:

1*--Margin= Maximum mark level- specification limit.

6.7.5 Test screenshot

6.7.5.1 700MHz Band

6.7.5.1.1 Frequency rang: 758MHz~768MHz/788MHz~798MHz

(1). Downlink

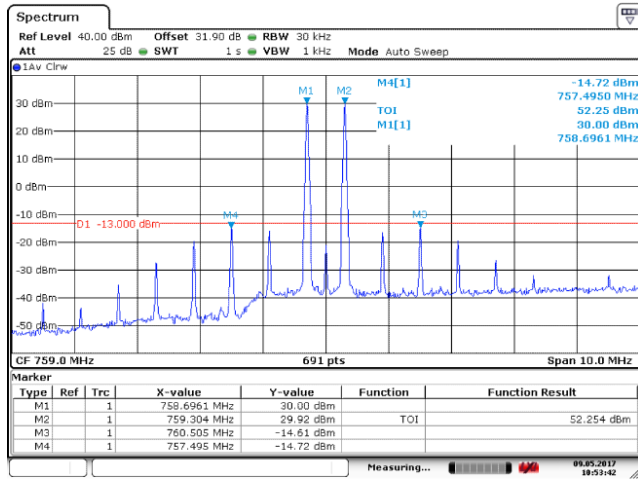

Date: 9.MAY.2017 10:53:42

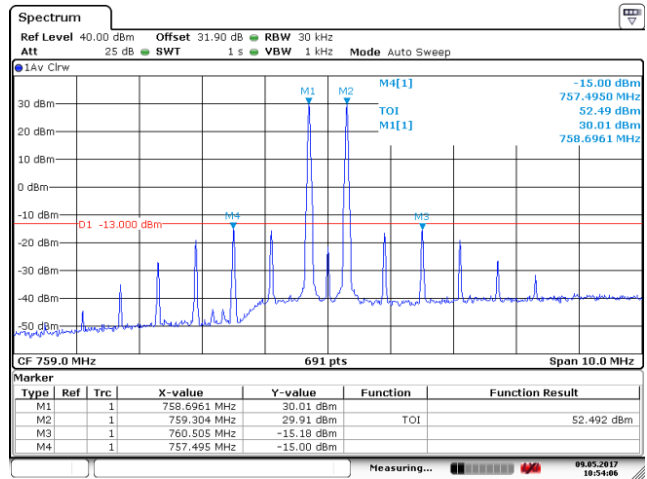

Date: 9.MAY.2017 10:54:06

Low Frequency and With the ALC threshold level

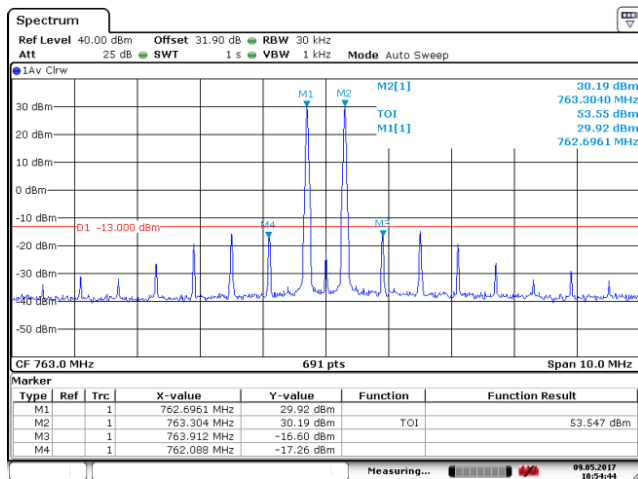

Date: 9.MAY.2017 10:54:44

Low Frequency and With the input signal amplitude set 3 dB above the ALC threshold

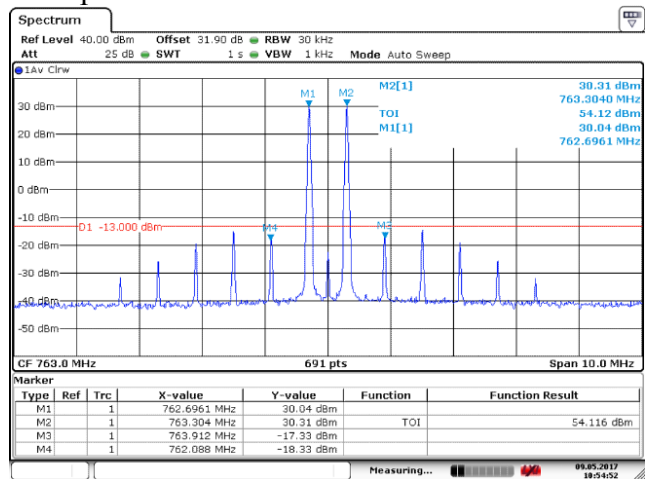

Date: 9.MAY.2017 10:54:52

Mid Frequency and With the ALC threshold level

Mid Frequency and With the input signal amplitude set 3 dB above the ALC threshold

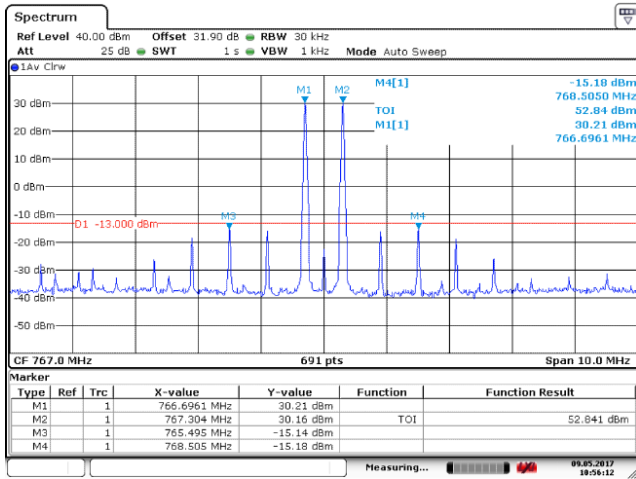

Date: 9.MAY.2017 10:56:12

High Frequency and With the ALC threshold level

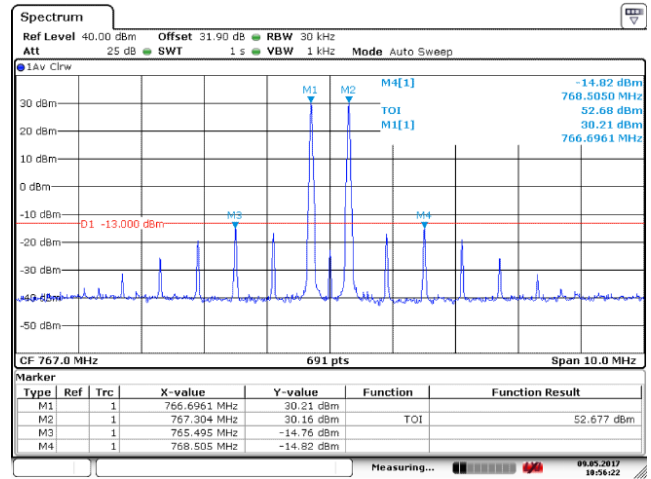

Date: 9.MAY.2017 10:56:22

High Frequency and With the input signal amplitude set 3 dB above the ALC threshold

(2). Uplink

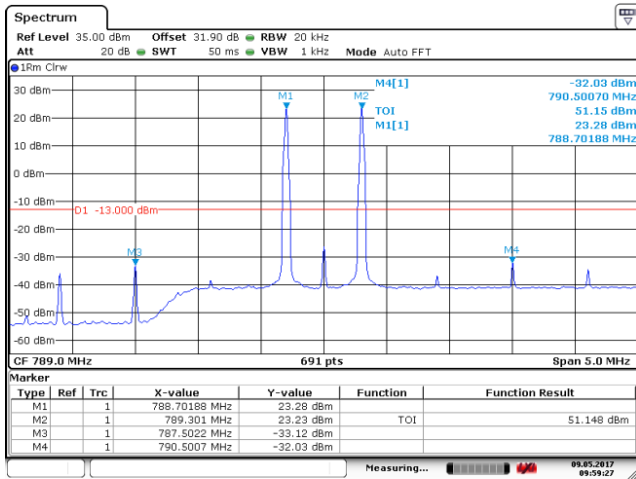

Date: 9.MAY.2017 09:59:26

Low Frequency and With the ALC threshold level

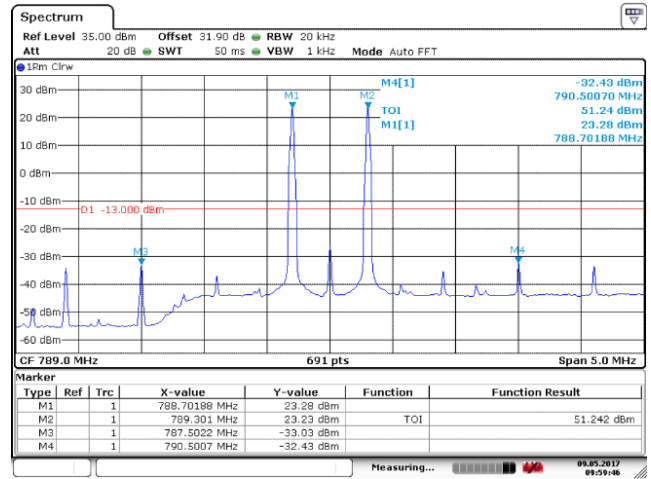

Date: 9.MAY.2017 09:59:46

Low Frequency and With the input signal amplitude set 3 dB above the ALC threshold

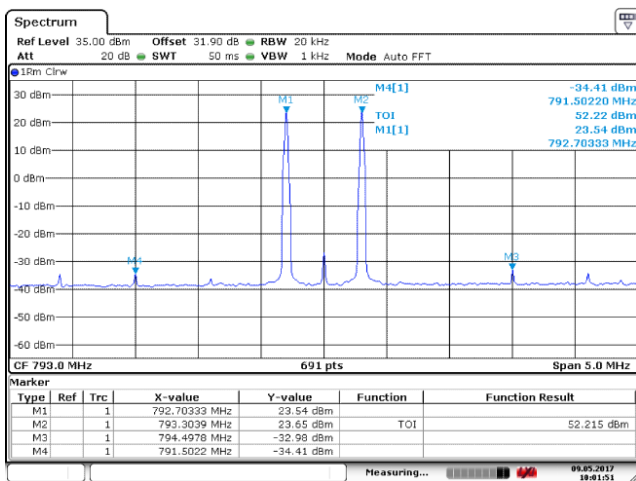

Date: 9.MAY.2017 10:01:51

Mid Frequency and With the ALC threshold level

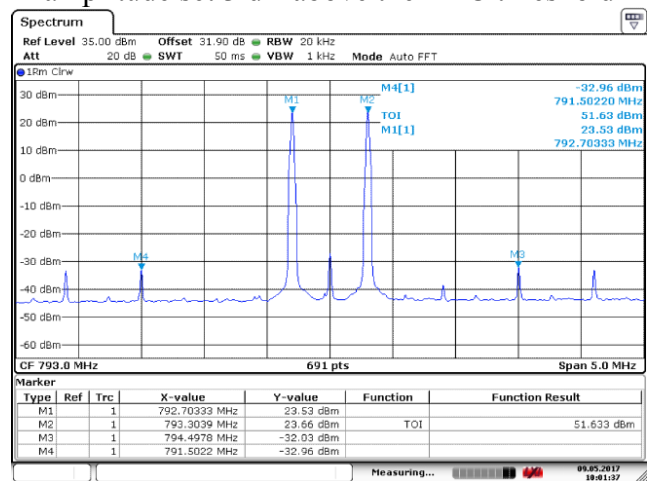

Date: 9.MAY.2017 10:01:37

Mid Frequency and With the input signal amplitude set 3 dB above the ALC threshold

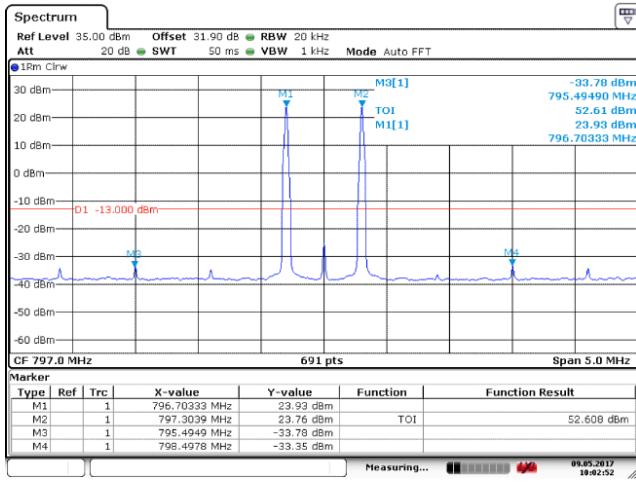

Date: 9.MAY.2017 10:02:52

High Frequency and With the ALC threshold level

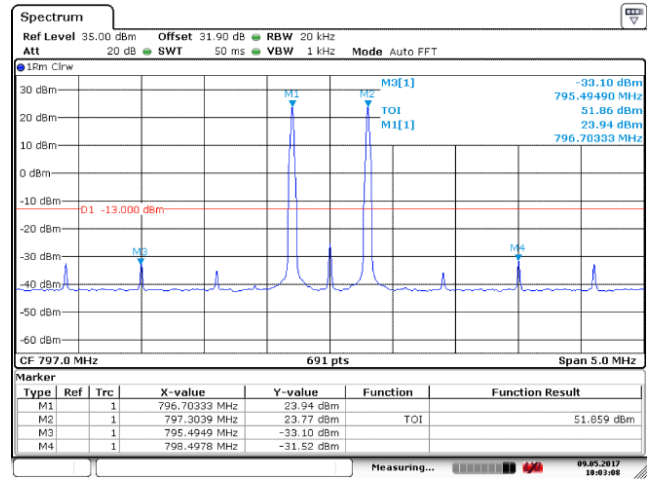

Date: 9.MAY.2017 10:03:08

High Frequency and With the input signal amplitude set 3 dB above the ALC threshold

6.7.5.1.2 Frequency rang: 769MHz~775MHz/799MHz~805MHz

(1) Channel bandwidth 12.5kHz

(1.1) Downlink

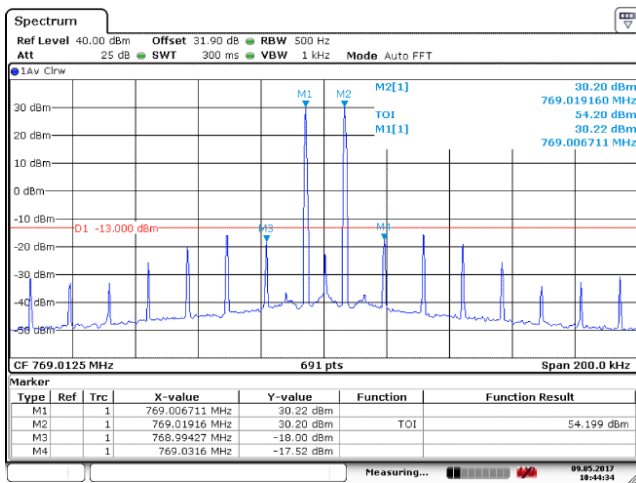

Date: 9.MAY.2017 10:44:34

Low Frequency and With the ALC threshold level

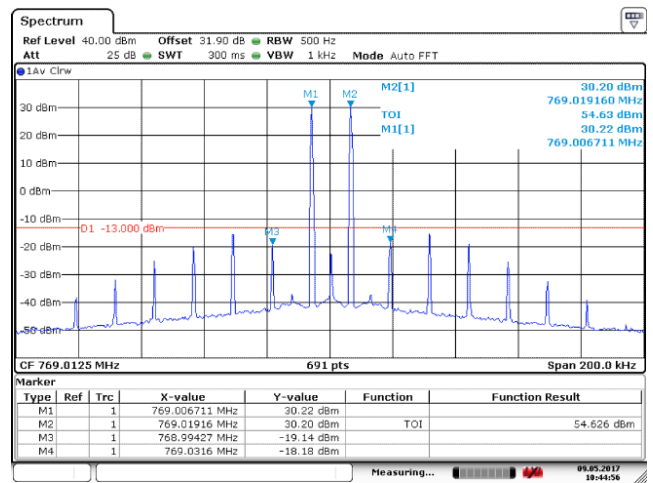

Date: 9.MAY.2017 10:44:57

Low Frequency and With the input signal amplitude set 3 dB above the ALC threshold

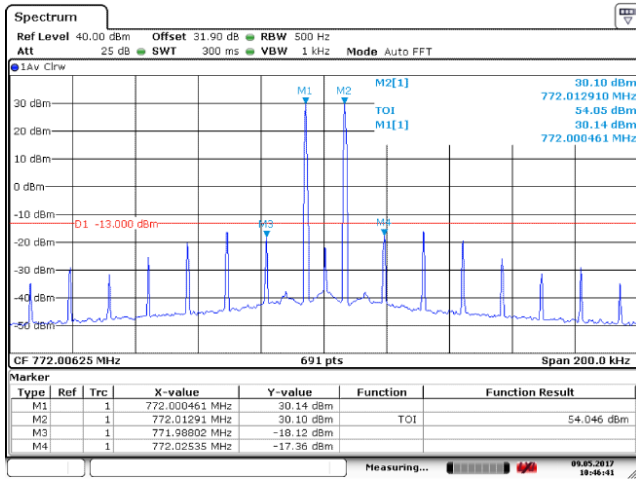

Date: 9.MAY.2017 10:46:41

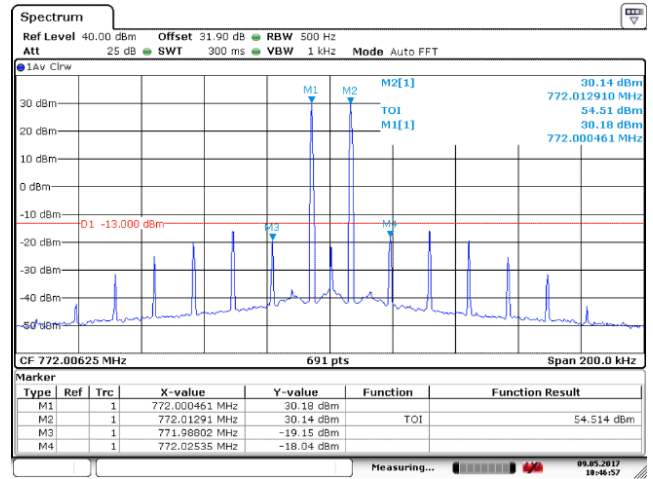

Date: 9.MAY.2017 10:46:57

Mid Frequency and With the ALC threshold level

Mid Frequency and With the input signal amplitude set 3 dB above the ALC threshold

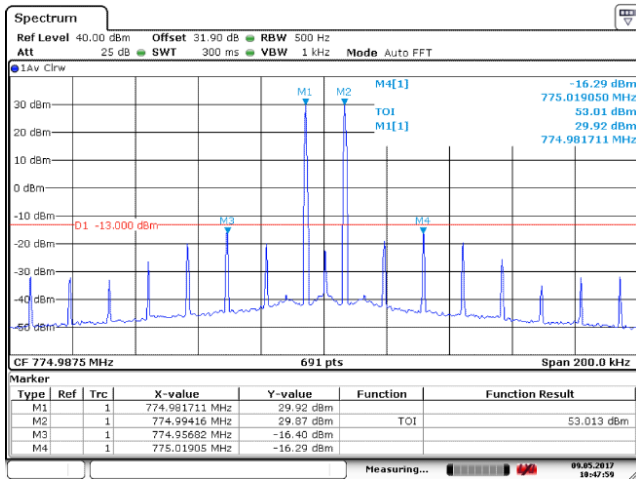

Date: 9.MAY.2017 10:47:59

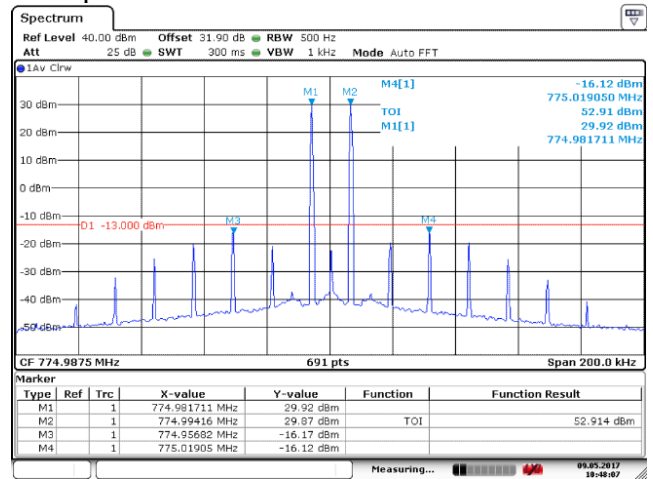

Date: 9.MAY.2017 10:48:07

High Frequency and With the ALC threshold level

High Frequency and With the input signal amplitude set 3 dB above the ALC threshold

(1.2) Uplink

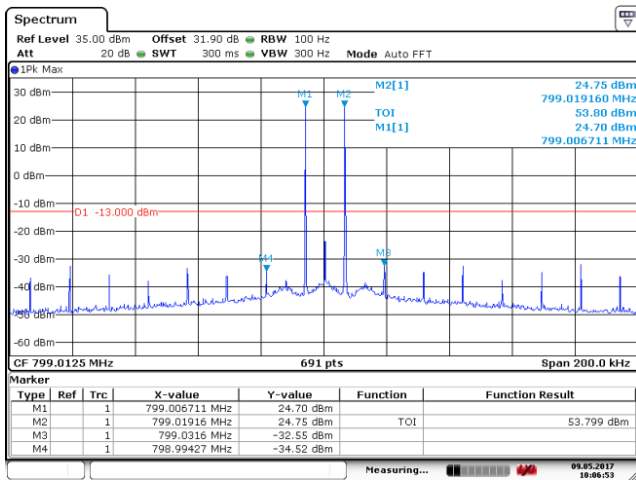

Date: 9.MAY.2017 10:06:53

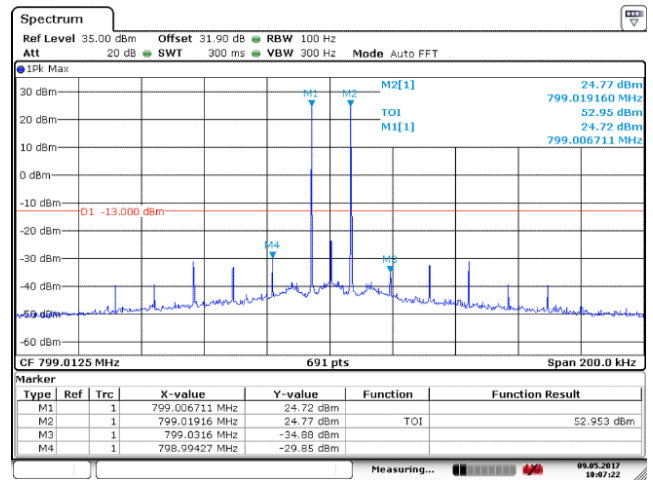

Date: 9.MAY.2017 10:07:22

Low Frequency and With the ALC threshold level

Low Frequency and With the input signal amplitude set 3 dB above the ALC threshold

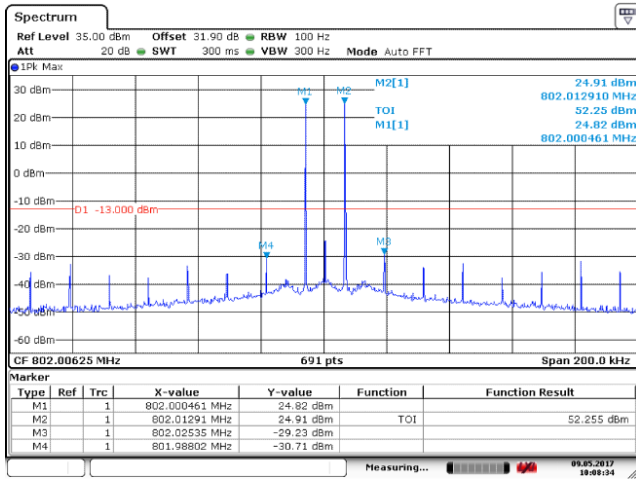

Date: 9.MAY.2017 10:08:34

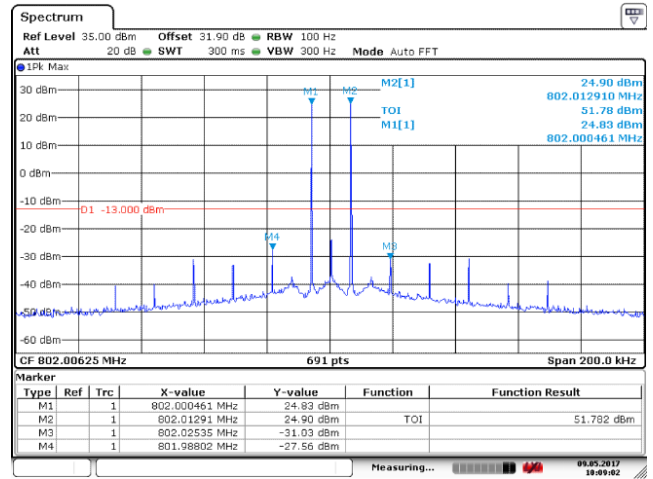

Date: 9.MAY.2017 10:09:03

Mid Frequency and With the ALC threshold level

Mid Frequency and With the input signal amplitude set 3 dB above the ALC threshold

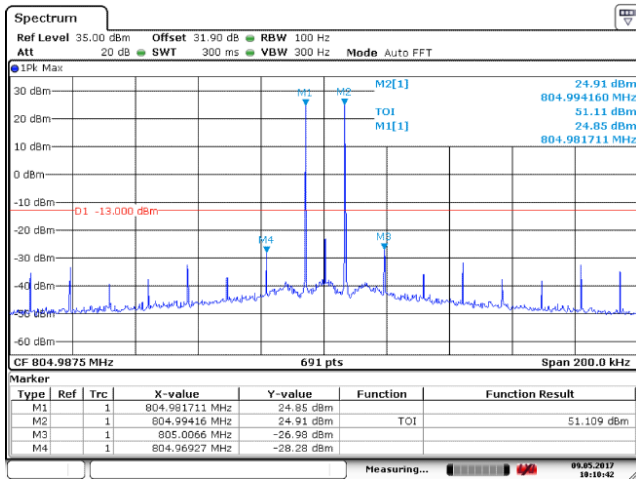

Date: 9.MAY.2017 10:10:42

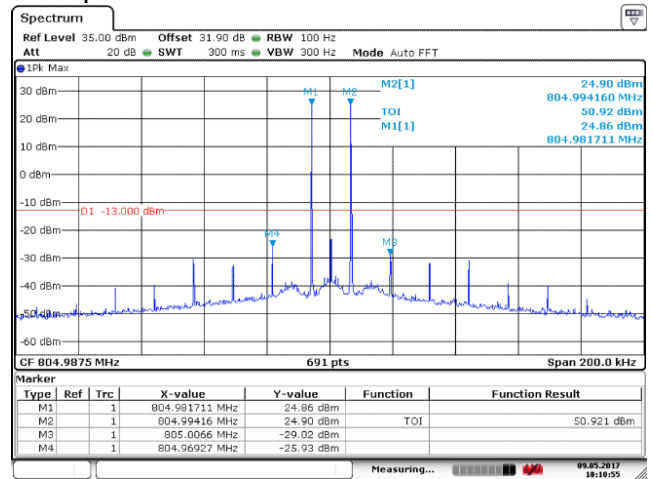

Date: 9.MAY.2017 10:10:55

High Frequency and With the ALC threshold level

High Frequency and With the input signal amplitude set 3 dB above the ALC threshold

(2) Channel bandwidth 25kHz

(2.1) Downlink

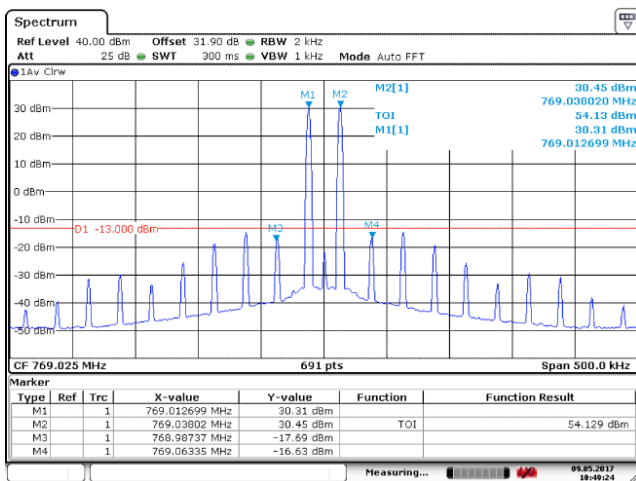

Date: 9.MAY.2017 10:49:24

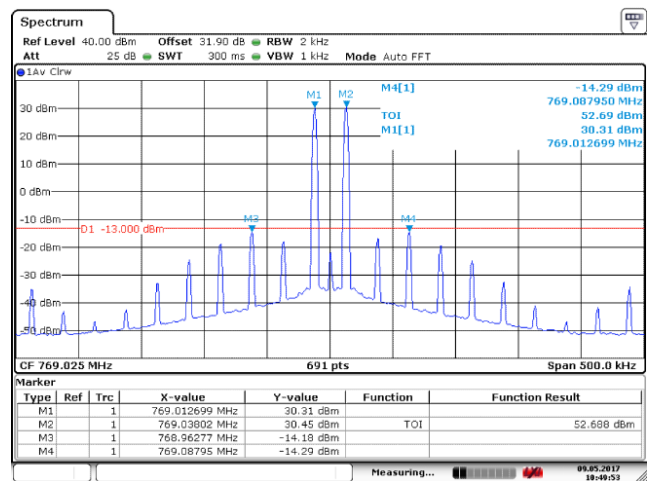

Date: 9.MAY.2017 10:49:53

Low Frequency and With the ALC threshold level

Low Frequency and With the input signal amplitude set 3 dB above the ALC threshold

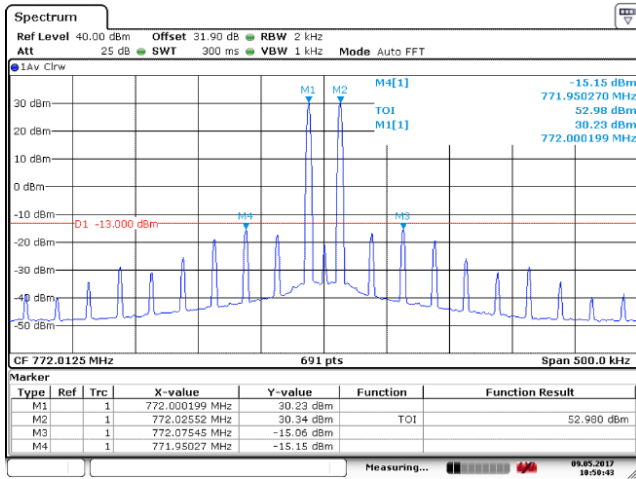

Date: 9.MAY.2017 10:50:43

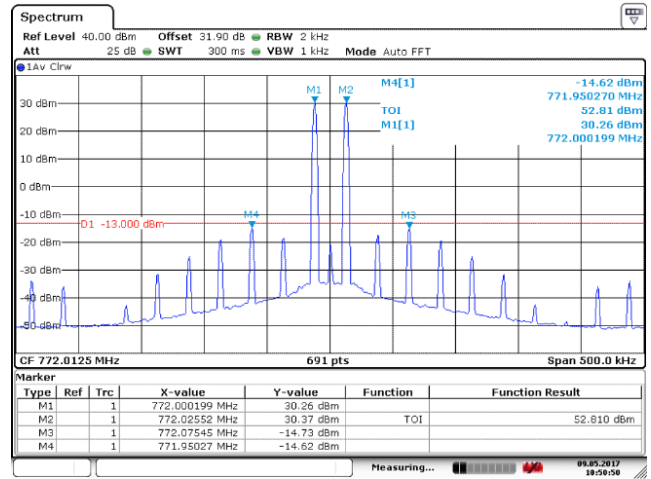

Date: 9.MAY.2017 10:50:50

Mid Frequency and With the ALC threshold level

Mid Frequency and With the input signal amplitude set 3 dB above the ALC threshold

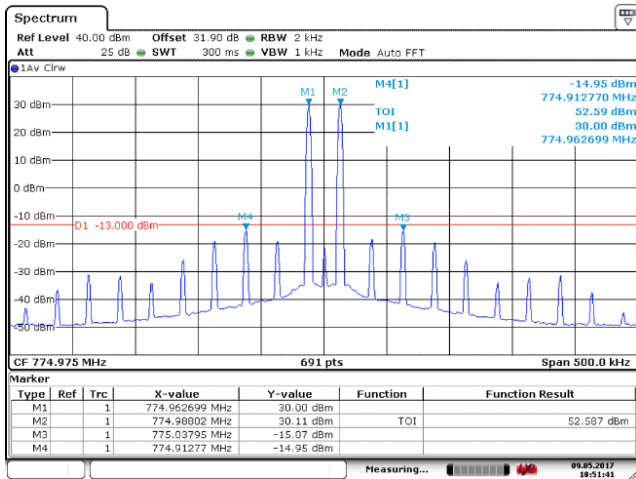

Date: 9.MAY.2017 10:51:41

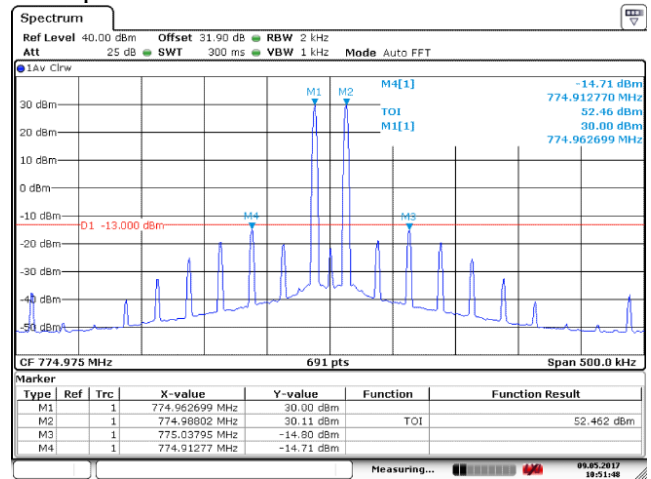

Date: 9.MAY.2017 10:51:48

High Frequency and With the ALC threshold level

High Frequency and With the input signal amplitude set 3 dB above the ALC threshold

(2.2) Uplink

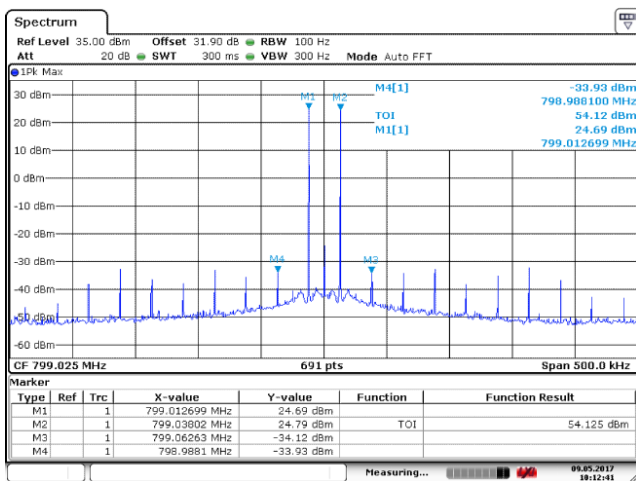

Date: 9.MAY.2017 10:12:41

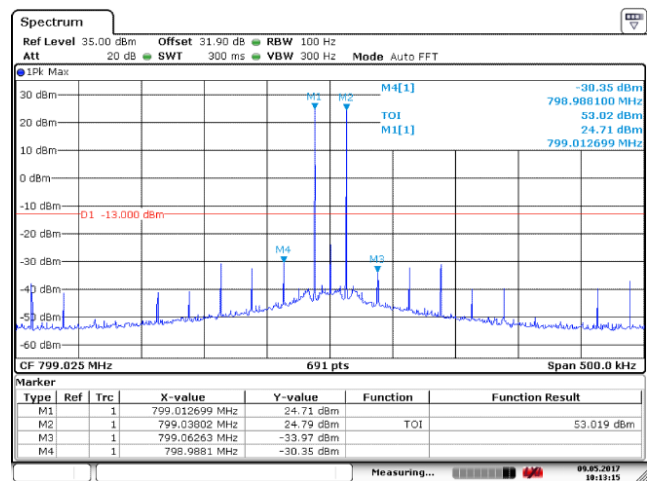

Date: 9.MAY.2017 10:13:15

Low Frequency and With the ALC threshold level

Low Frequency and With the input signal amplitude set 3 dB above the ALC threshold

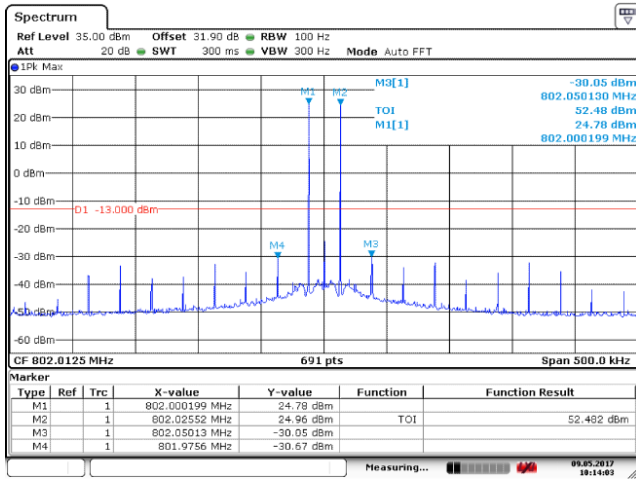

Date: 9.MAY.2017 10:14:03

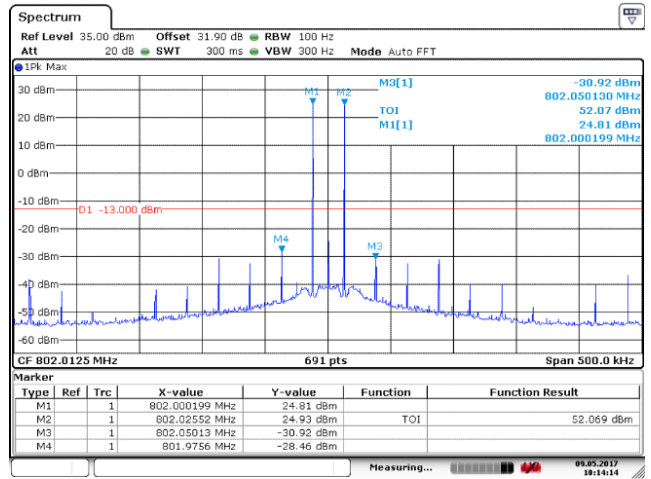

Date: 9.MAY.2017 10:14:14

Mid Frequency and With the ALC threshold level

Mid Frequency and With the input signal amplitude set 3 dB above the ALC threshold

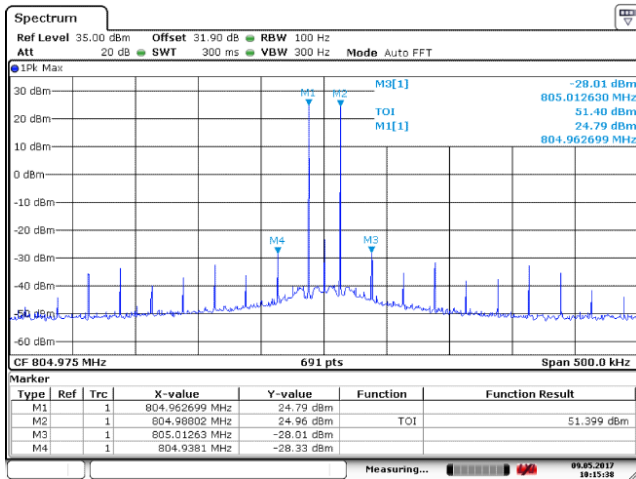

Date: 9.MAY.2017 10:15:38

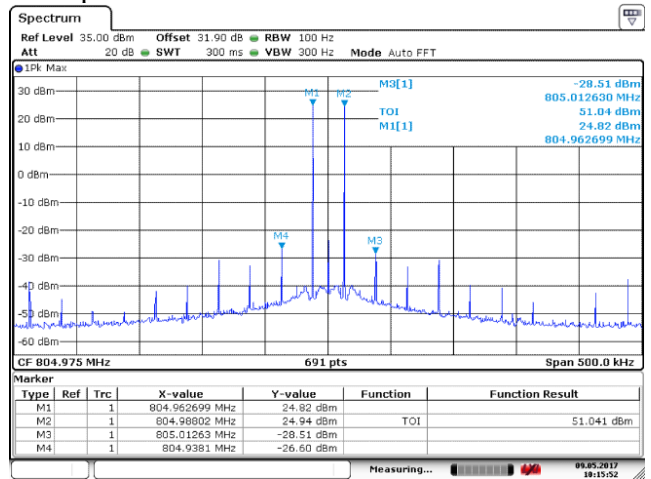

Date: 9.MAY.2017 10:15:52

High Frequency and With the ALC threshold level

High Frequency and With the input signal amplitude set 3 dB above the ALC threshold

6.7.5.2 800MHz Band

(1). Channel bandwidth 12.5kHz

(1.1) Downlink

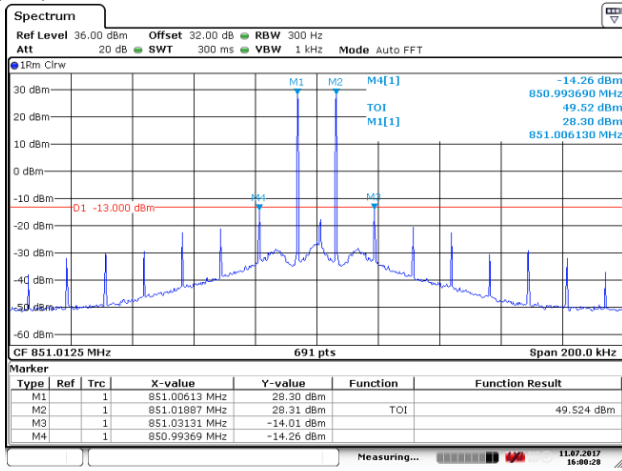

Date: 11.JUL.2017 16:00:28

Low Frequency 12and With the ALC threshold level

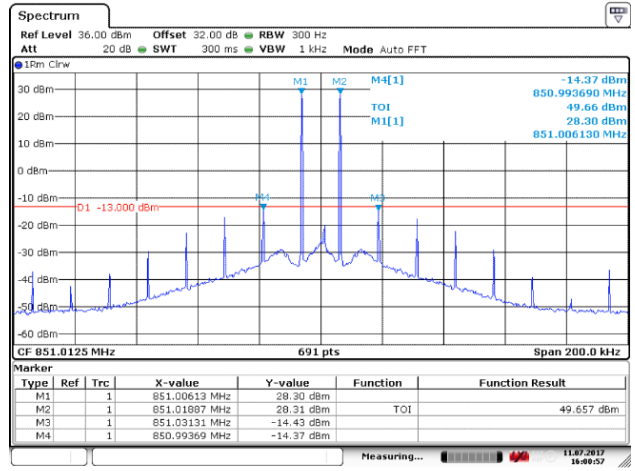

Date: 11.JUL.2017 16:00:57

Low Frequency and With the input signal amplitude set 3 dB above the ALC threshold

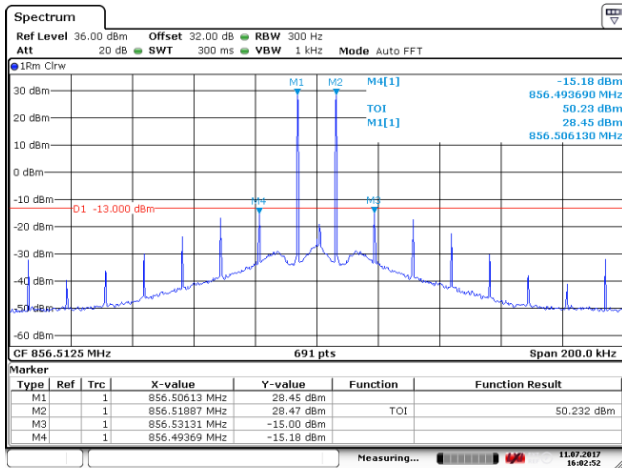

Date: 11.JUL.2017 16:02:52

Mid Frequency and With the ALC threshold level

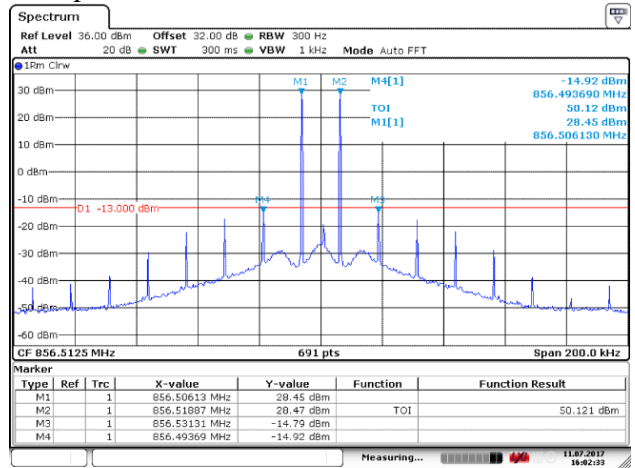

Date: 11.JUL.2017 16:02:33

Mid Frequency and With the input signal amplitude set 3 dB above the ALC threshold

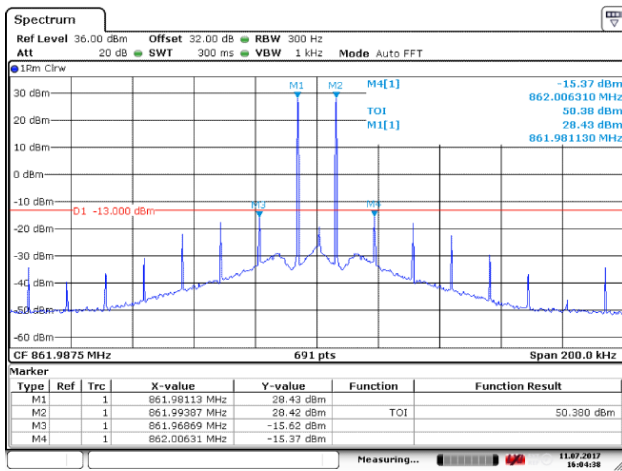

Date: 11.JUL.2017 16:04:38

High Frequency and With the ALC threshold level

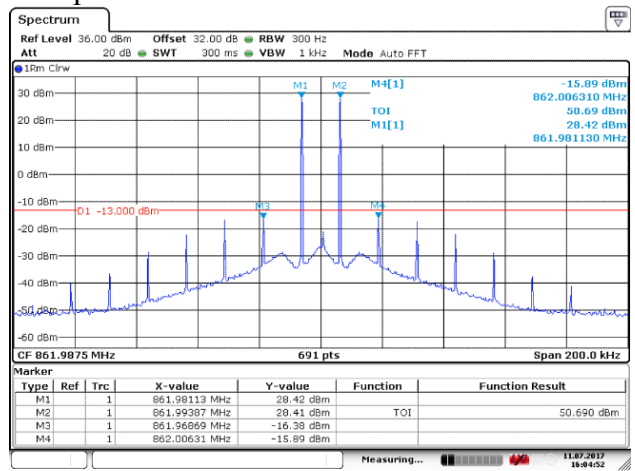

Date: 11.JUL.2017 16:04:52

High Frequency and With the input signal amplitude set 3 dB above the ALC threshold

(1.2) Uplink

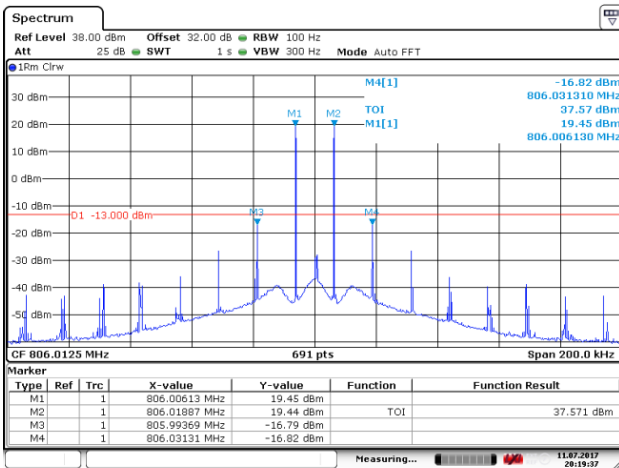

Date: 11.JUL.2017 20:19:37

Low Frequency and With the ALC threshold level

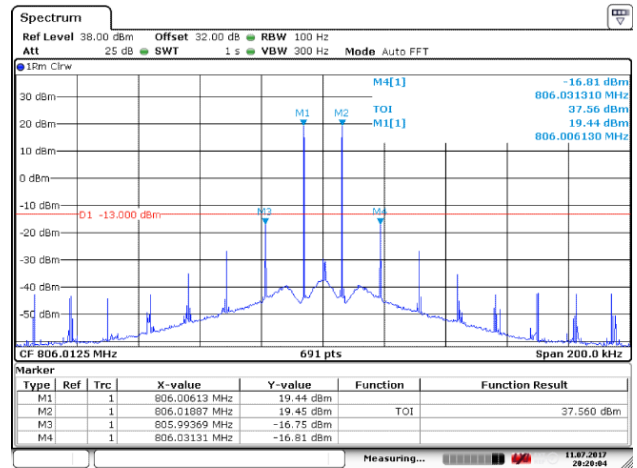

Date: 11.JUL.2017 20:20:04

Low Frequency and With the input signal amplitude set 3 dB above the ALC threshold

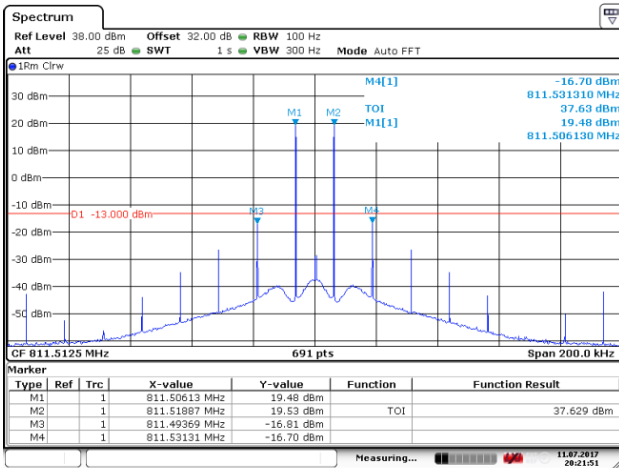

Date: 11.JUL.2017 20:21:51

Mid Frequency and With the ALC threshold level

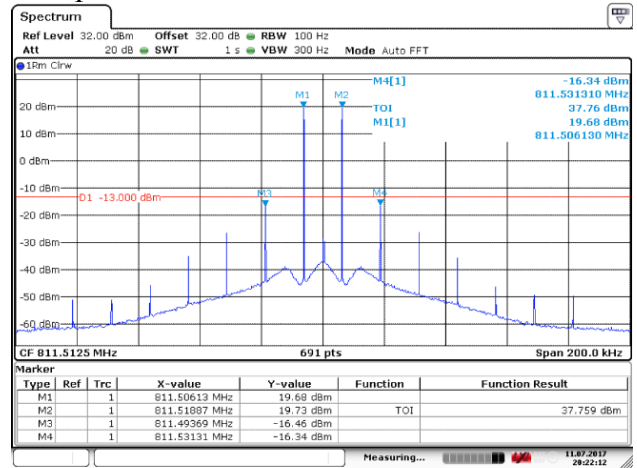

Date: 11.JUL.2017 20:22:12

Mid Frequency and With the input signal amplitude set 3 dB above the ALC threshold

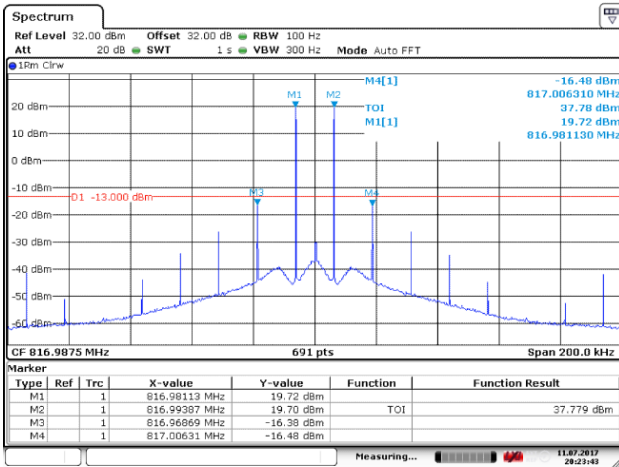

Date: 11.JUL.2017 20:23:43

High Frequency and With the ALC threshold level

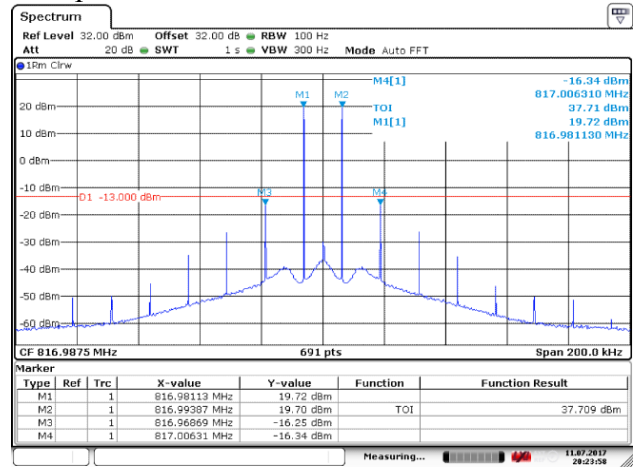

Date: 11.JUL.2017 20:23:58

High Frequency and With the input signal amplitude set 3 dB above the ALC threshold

(2). Channel bandwidth 25kHz

(2.1) Downlink

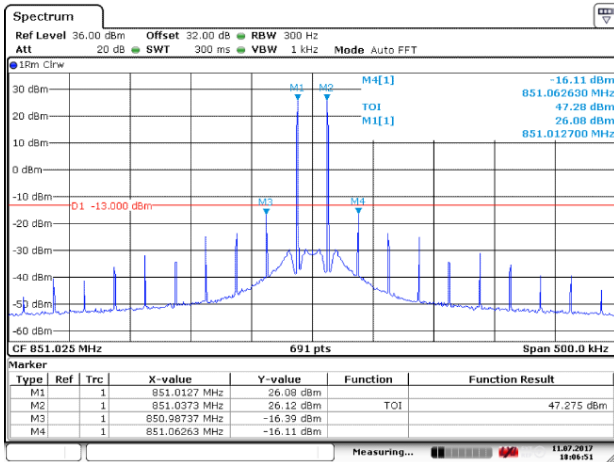

Date: 11.JUL.2017 18:06:51

Low Frequency 12and With the ALC threshold level

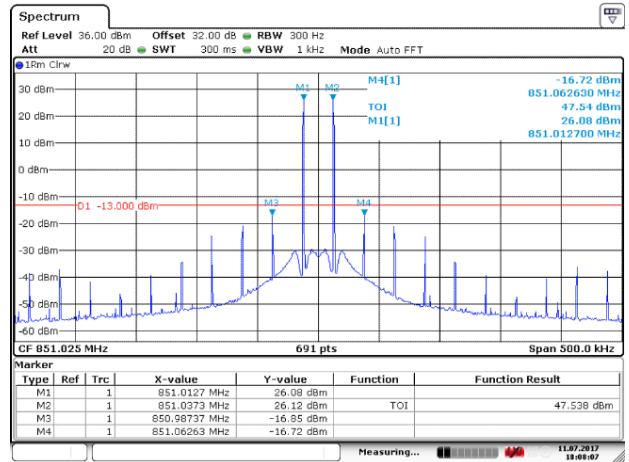

Date: 11.JUL.2017 18:08:07

Low Frequency and With the input signal amplitude set 3 dB above the ALC threshold

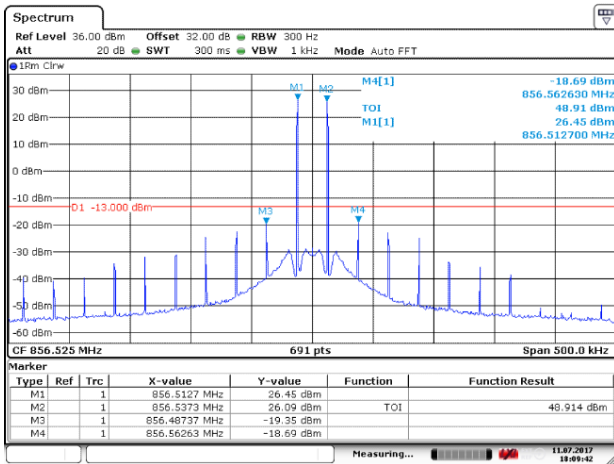

Date: 11.JUL.2017 18:09:42

Mid Frequency and With the ALC threshold level

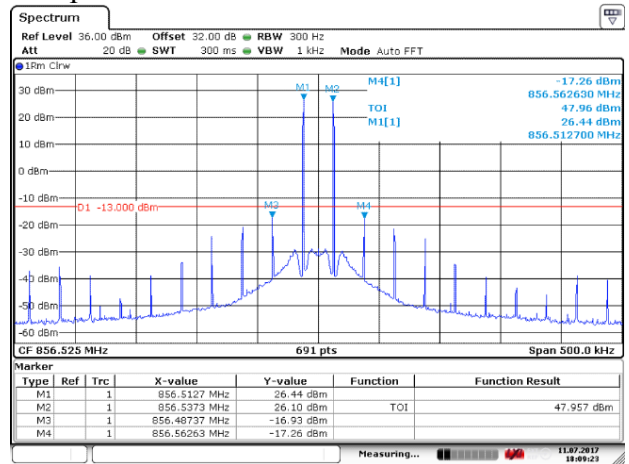

Date: 11.JUL.2017 18:09:23

Mid Frequency and With the input signal amplitude set 3 dB above the ALC threshold

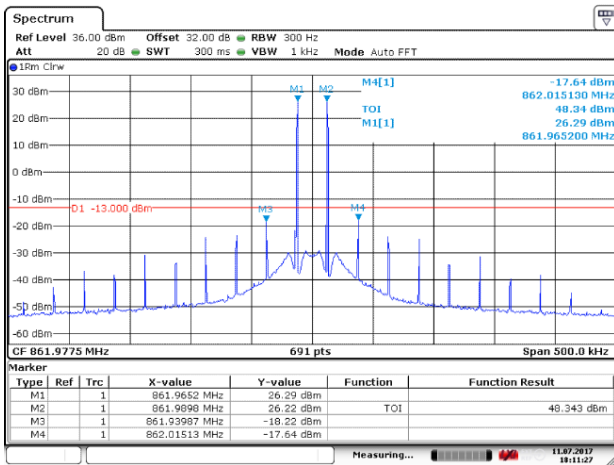

Date: 11.JUL.2017 18:11:27

High Frequency and With the ALC threshold level

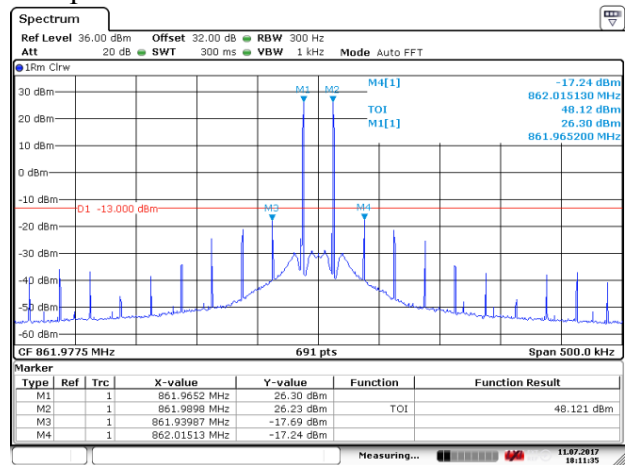

Date: 11.JUL.2017 18:11:35

High Frequency and With the input signal amplitude set 3 dB above the ALC threshold

6.8 Radiated spurious emissions

Test Date (yy-mm-dd): 2017-05-28

Test environment: Normal

Ambient Temp 22.3°C, Humid 52%, Atmospheric Pressure 101kpa

Power supply: AC 120V 50/60Hz
DC -48V

Test Method: KDB 935210 D05 Indus Booster Basic Meas v01r01
EIA/TIA 603- D-2010/2.2.12

Test Requirement: FCC part 90.219(e)(3)

6.8.1 Limit

This test was performed to measure radiated spurious emissions from the EUT. Specification test limits are given in Table 12.

Table 12 Radiated spurious emission test limits

Frequency	Attenuation below carrier(dBc)	ERP of Spurious(dBm)	Equivalent field strength limit @3m dB(uV/m)*
30~10 th harmonic**	43+10logP***	-13	84.4

Notes: *-- Equivalent field strength limit was calculated from maximum allowed ERP of spurious as follows:

$E = \sqrt{30 \cdot P \cdot 1.64} / r$, where P is ERP in Watts, 1.64 is numeric gain of ideal dipole and r is antenna to EUT distance in meters.

**--Excluding the in band emission within ±250% of the authorized bandwidth from the carrier.

***--P is transmitter output power in Watts.

6.8.2 Test configuration

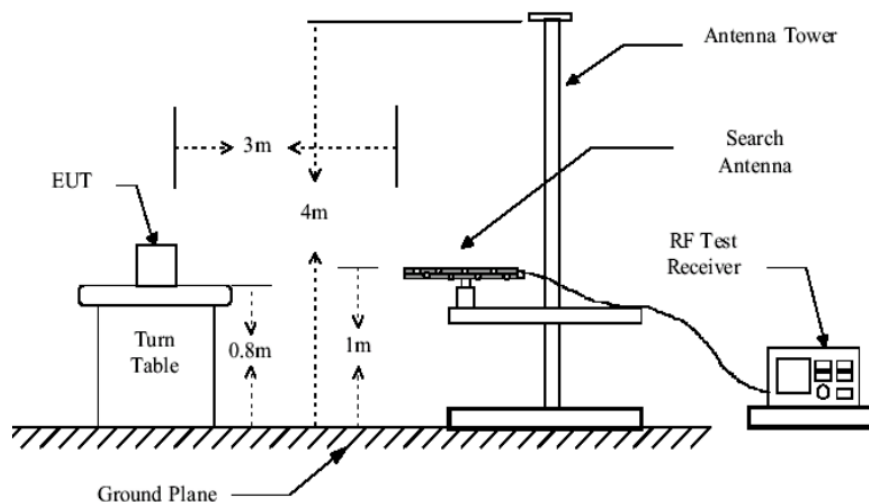

Figure 15: 30 MHz to 1 GHz radiated emissions test configuration

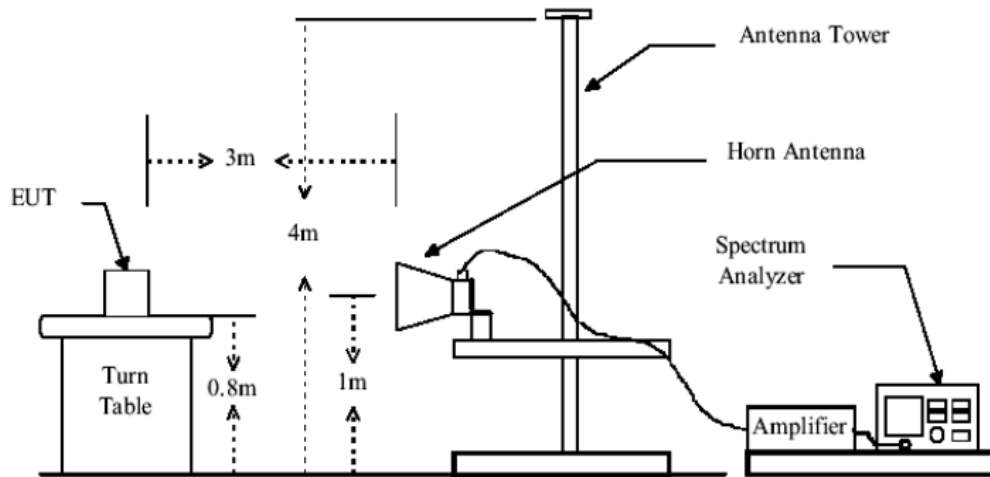

Figure 16: Above 1 GHz radiated emissions test configuration

6.8.3 Test procedures

- a) Connect the device as illustrated;
- b) Adjust the spectrum analyzer for the following setting;
 - 1) RBW=100kHz for spurious emission below 1 GHz, and 1MHz for spurious emission above 1GHz;
 - 2) VBW=300k for spurious emission below 1GHz, and 3MHz for spurious emission above 1GHz;
 - 3) Sweep speed slow enough to maintain measurement calibration;
 - 4) Detector Mode= Positive Peak;
- c) Place the transmitter to be tested on the turntable in the standard test site, or and FCC listed site compliant with ANSI C63.4-2001 clause 5.4. The transmitter is transmitting into a nonradiating load that is placed on the turntable, the RF cable to this load should be of minimum length. For transmitters with integral antennas, the tests are to be run with the unit operating into the integral antenna.
- d) For each spurious measurement the test antenna should be adjusted to the correct length for the frequency involved. This length may be determined from a calibration ruler supplied with the device. Measurements shall be made from the lowest radio frequency generated in the device to the tenth harmonic of the carrier, except for the region close to the carrier equal to \pm the test bandwidth.
- e) Key the transmitter with normal modulation base the standard.
- f) For each spurious frequency, raise and lower the test antenna from 1 m to 4 m to obtain a maximum reading on the spectrum analyzer with the test antenna at horizontal polarity. Then

the turntable should be rotated 360° to determine the maximum reading. Repeat this procedure to obtain the highest possible reading. Record this maximum reading.

- g) Repeat step f) for each spurious frequency with the test antenna polarized vertically.

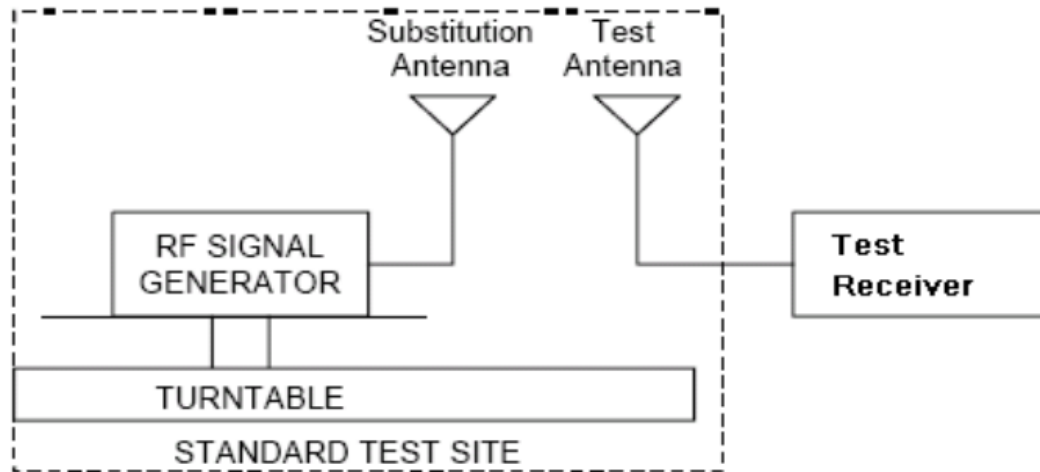

- h) Reconnect the device as illustrated.
- i) Keep the spectrum analyzer adjusted as in step b).
- j) Remove the transmitter and replace it with a substitution antenna (the antenna should be half-wavelength for each frequency involved). The center of the substitution antenna should be approximately at the same location as the center of the transmitter. At the lower frequencies where the substitution antenna is very long, this will be impossible to achieve when the antenna is polarized vertically, in such case the lower end of the antenna should be 0.3m above the ground.
- k) Feed the substitution antenna at the transmitter end with a signal generator connected to the antenna by means of a nonradiating cable. With the antennas at both ends horizontally polarized, and with the signal generator tuned to a particular spurious frequency, raise and lower the test antenna to obtain a maximum reading at the spectrum analyzer. Adjust the level of the signal generator output until the previously recorded maximum reading or this set of conditions is obtained, this should be done carefully repeating the adjustment of the test antenna and generator output.
- l) Repeat step k) with both antennas vertically polarized for each spurious frequency.
- m) Calculate power in dBm into a reference ideal half-wave dipole antenna by reducing the readings obtained in step k) and i) by the power loss in the cable between the generator and the antenna, and further corrected for the gain of the substitution antenna used relative to an ideal half-wave dipole antenna by the following formula:

$$Pd(\text{dBm})=Pg(\text{dBm})-\text{cable loss}(\text{dB})+\text{antenna gain}(\text{dB})$$

Where:

Pd is the dipole equivalent power and Pg is the generator output power into the substitution antenna.

NOTE: It is permissible to use other antennas provided they can be referenced to a dipole.

NOTE: Effective radiated power(e.r.p) refers to the radiation of a half wave tuned dipole instead of and isotropic antenna. There is a constant difference of 2.15 dB between e.i.r.p and e.r.p.

$$e.r.p.(\text{dBm})=e.i.r.p(\text{dB})-2.15$$

6.8.4 Test Results

6.8.4.1 700MHz Band

(1) Input Power: AC 120V, 50/60Hz

Vertical		Limit(dBm)	Margin(dB)	Result
Test Frequency (MHz)	Measuring level (dBm)			
Frequency range: 30MHz to 1GHz				
33.5684	-51.25	≤-13dBm	-38.25	pass
48.9153	-44.08		-31.08	pass
86.7716	-53.00		-40.00	pass
127.8713	-57.80		-44.80	pass
384.6920	-59.59		-46.59	pass
929.5512	-56.32		-43.32	pass
Frequency range: 1GHz to 6GHz				
2477.786	-46.97	≤-13dBm	-33.97	pass
2542.653	-47.09		-34.09	pass
3264.220	-47.42		-34.42	pass
3672.044	-47.67		-34.67	pass
5457.566	-47.30		-34.30	pass
5830.165	-47.92		-34.92	pass
Note: Sweep all the modulation types emissions in 700MHz Band , find the worse case to report it.				

Horizontal		Limit(dBm)	Margin(dB)	Result
Test Frequency (MHz)	Measuring level (dBm)			
Frequency range: 30MHz to 1GHz				
44.2096	-54.76	≤-13dBm	-41.76	pass
45.7255	-54.78		-41.78	pass
66.2571	-60.08		-47.08	pass
85.8019	-60.18		-47.18	pass
384.6920	-59.71		-46.71	pass
919.1625	-57.33		-44.33	pass
Frequency range: 1GHz to 6GHz				
2442.466	-47.53	≤-13dBm	-34.53	pass
2827.662	-47.16		-34.16	pass
4060.263	-46.45		-33.45	pass
4263.378	-46.82		-33.82	pass
5079.525	-46.90		-33.90	pass
5318.335	-46.93		-33.93	pass
Note: Sweep all the modulation types emissions in 700MHz Band , find the worse case to report it.				

(2) Input Power: DC -48V

Vertical		Limit(dBm)	Margin(dB)	Result
Test Frequency (MHz)	Measuring level (dBm)			
Frequency range: 30MHz to 1GHz				
48.0977	-43.47	≤-13dBm	-30.47	pass
66.2571	-52.28		-39.28	pass
77.9844	-52.88		-39.88	pass
87.2605	-53.97		-40.97	pass
384.6920	-59.66		-46.66	pass
919.1625	-56.70		-43.70	pass
Frequency range: 1GHz to 6GHz				
2319.434	-47.63	≤-13dBm	-34.63	pass
2477.786	-47.75		-34.75	pass
2669.849	-47.70		-34.70	pass

4287.932	-47.42		-34.42	pass
5212.504	-47.87		-34.87	pass
5681.428	-47.86		-34.86	pass
Note: Sweep all the modulation types emissions in 700MHz Band , find the worse case to report it.				

Horizontal		Limit(dBm)	Margin(dB)	Result
Test Frequency (MHz)	Measuring level (dBm)			
Frequency range: 30MHz to 1GHz				
44.7092	-55.23	≤-13dBm	-42.23	pass
47.5600	-55.78		-42.78	pass
77.1128	-61.61		-48.61	pass
141.4823	-65.36		-52.36	pass
384.6920	-59.98		-46.98	pass
929.5512	-56.61		-43.61	pass
Frequency range: 1GHz to 6GHz				
2456.533	-47.53	≤-13dBm	-34.53	pass
2747.623	-47.94		-34.94	pass
3945.334	-47.18		-34.18	pass
4107.167	-46.63		-33.63	pass
5094.131	-46.10		-33.10	pass
5395.241	-46.71		-33.71	pass
Note: Sweep all the modulation types emissions in 700MHz Band , find the worse case to report it.				

6.8.4.2 800MHz Band

(3) Input Power: AC 120V, 50/60Hz

Vertical		Limit(dBm)	Margin(dB)	Result
Test Frequency (MHz)	Measuring level (dBm)			
Frequency range: 30MHz to 1GHz				
44.2096	-40.82	≤-13dBm	-27.82	pass
47.0285	-40.01		-27.01	pass
64.4213	-46.08		-33.08	pass
77.5474	-47.15		-34.15	pass

384.6920	-57.17		-44.17	pass
908.8899	-56.67		-43.67	pass
Frequency range: 1GHz to 6GHz				
2572.025	-47.22	≤-13dBm	-34.22	pass
2803.408	-47.85		-34.85	pass
3934.022	-47.03		-34.03	pass
4095.390	-47.41		-34.41	pass
5123.470	-47.43		-34.43	pass
5395.241	-47.78		-34.78	pass
Note: Sweep all the modulation types emissions in 700MHz Band , find the worse case to report it.				

(4) Input Power: DC -48V

Vertical		Limit(dBm)	Margin(dB)	Result
Test Frequency (MHz)	Measuring level (dBm)			
Frequency range: 30MHz to 1GHz				
44.4587	-41.35	≤-13dBm	-28.35	pass
47.5600	-41.29		-28.29	pass
65.8859	-47.60		-34.60	pass
76.2510	-47.82		-34.82	pass
384.6920	-57.45		-44.45	pass
908.8899	-56.14		-43.14	pass
Frequency range: 1GHz to 6GHz				
2299.539	-48.34	≤-13dBm	-35.34	pass
2631.792	-47.09		-34.09	pass
3990.910	-47.71		-34.71	pass
4263.378	-47.54		-34.54	pass
5007.119	-47.20		-34.20	pass
5395.241	-47.28		-34.28	pass
Note: Sweep all the modulation types emissions in 700MHz Band , find the worse case to report it.				

Horizontal		Limit(dBm)	Margin(dB)	Result
Test Frequency (MHz)	Measuring level (dBm)			

Frequency range: 30MHz to 1GHz				
43.9617	-41.46	≤-13dBm	-28.46	pass
47.0285	-42.32		-29.32	pass
65.1495	-47.84		-34.84	pass
71.2787	-48.41		-35.41	pass
86.2853	-50.21		-37.21	pass
929.5511	-57.33		-44.33	pass
Frequency range: 1GHz to 6GHz				
2631.792	-47.09	≤-13dBm	-34.09	pass
2763.447	-47.82		-34.82	pass
3273.606	-47.47		-34.47	pass
3990.910	-47.71		-34.71	pass
4263.378	-47.54		-34.54	pass
5007.119	-47.20		-34.20	pass
Note: Sweep all the modulation types emissions in 700MHz Band , find the worse case to report it.				

APPENDIX A. PHOTOGRAPH OF THE TEST CONNECTION DIAGRAM

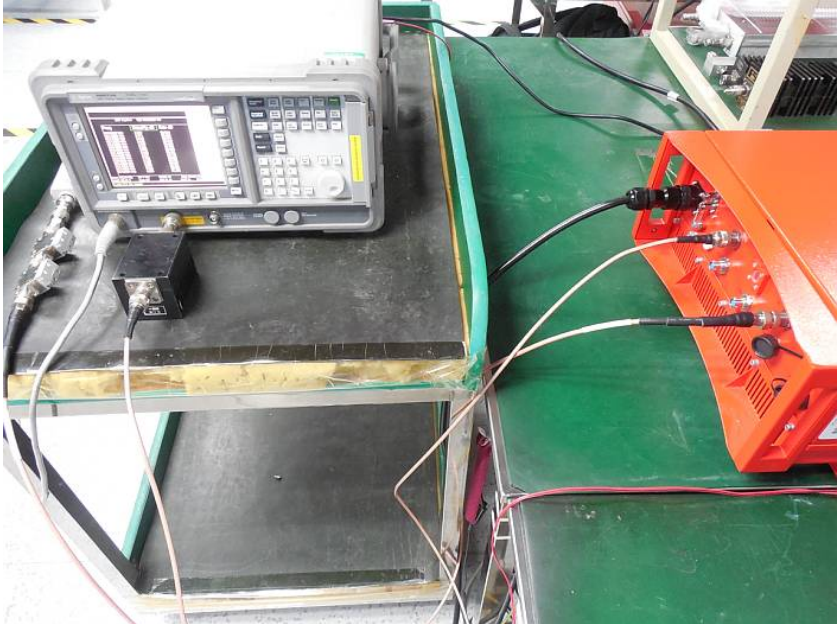
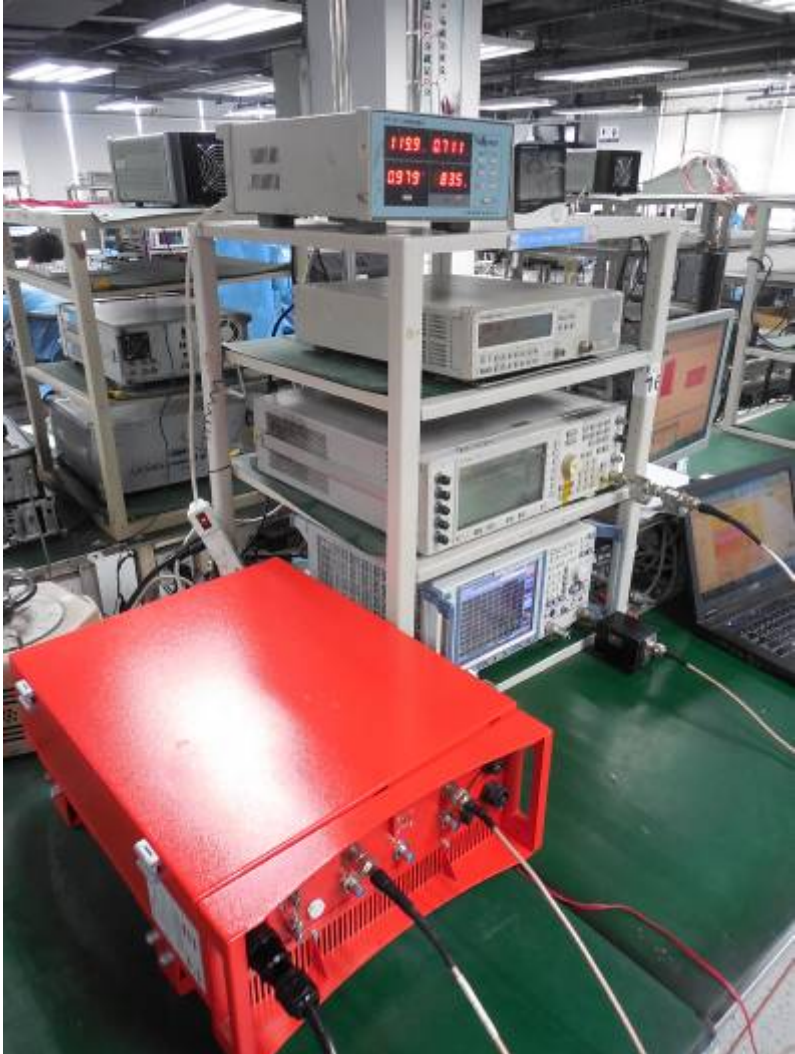

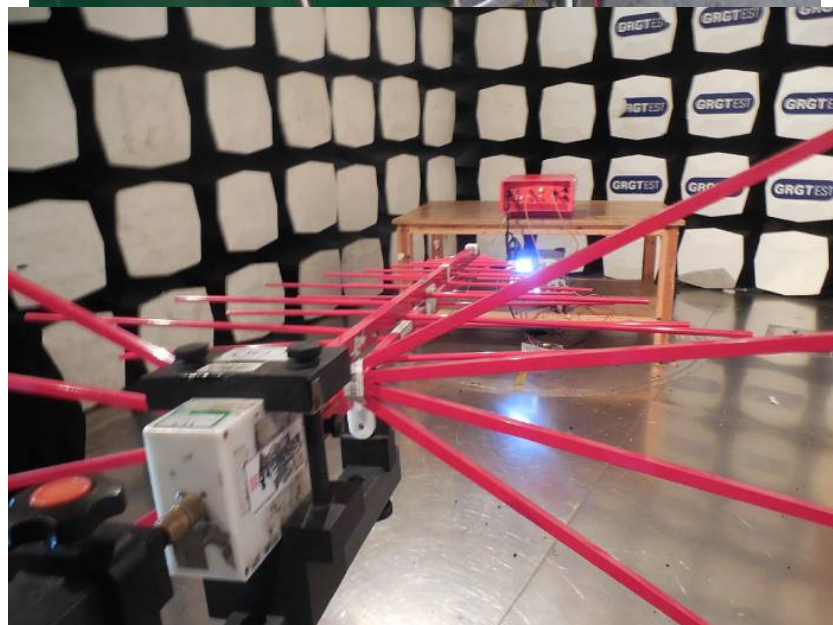

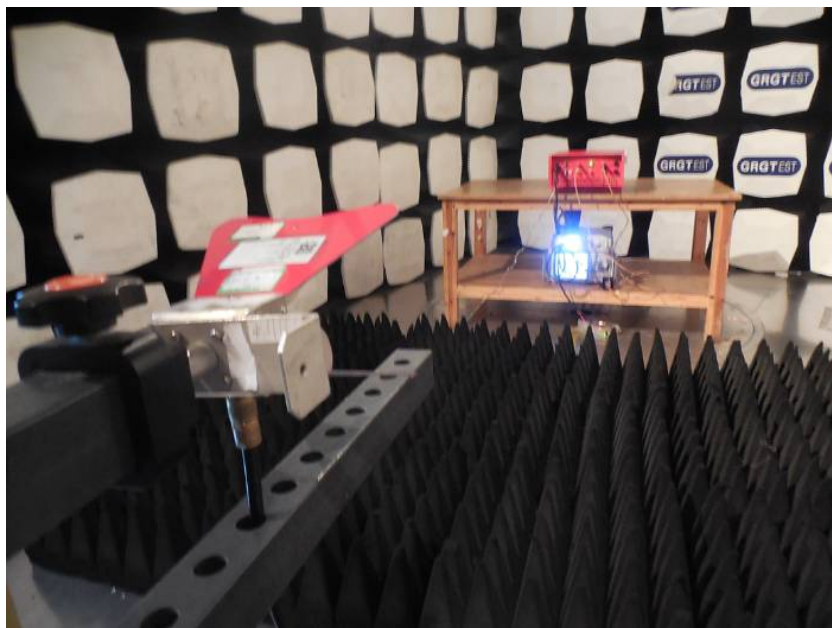

-----This is the last page of the report. -----