

Comba

Public Safety BDA

DIGITAL BAND SELECTIVE REPEATER

USER MANUAL

Public Safety BDA SERIES QE: 1-0-0

Comba Telecom Ltd.

The information contained herein is the responsibility of and is approved by the following, to whom all enquiries should be directed in the first instance:

This is an unpublished work the copyright in which vests in Comba International ("Comba"). All rights reserved.

The information contained herein is confidential and the property of Comba and is supplied without liability for errors or omissions. No part may be reproduced, disclosed or used except as authorised by contract or other written permission. The copyright and the foregoing restriction on reproduction and use extend to all media in which the information may be embodied.

0.1 CONTENTS

Section	Page
0.1	CONTENTS..... 3
0.2	INDEX TO FIGURES AND TABLES 4
0.3	HISTORY 5
0.4	GLOSSARY OF TERMS 6
0.5	SAFETY NOTICES AND ADMONISHMENTS 7
1	GENERAL INFORMATION..... 8
2	EQUIPMENT DESCRIPTION..... 9
2.1	FUNCTIONAL BLOCK DIAGRAM 9
2.2	EQUIPMENT LAYOUT 10
2.3	EQUIPMENT CONSTITUTION 11
3	INSTALLATION 12
3.1	WARNINGS AND ALERTS..... 12
3.2	SITE PLANNING CONSIDERATIONS 13
3.2.1	SITE PLANNING 13
3.2.2	INSTALLATION CHECKLIST 14
3.3	INSTALLATION PROCEDURES 15
3.3.1	GOODS INWARDS INSPECTION..... 15
3.3.2	TOOLS 15
3.3.3	PREPARATION 15
3.3.4	WALL MOUNTING 16
3.3.5	DRIP-LOOP 16
3.4	EQUIPMENT CONNECTORS..... 17
3.4.1	PS BDA CONNECTORS..... 17
3.4.2	PS BDA LED INDICATORS..... 18
3.4.3	GROUNDING CONNECTION 18
3.4.4	RF CABLE CONNECTION 18
3.4.5	ETHERNET CONNECTION 18
3.4.6	PHYSICAL CONNECTION TO OMT PC 19
4	COMMISSIONING 19
4.1	PRE-COMMISSIONING TASKS..... 19
4.2	COMMISSIONING PROCEDURE 20
5	WEB GUI 22
5.1	WEB GUI CONNECTION 22
5.2	WEB GUI INTRODUCTION..... 23
5.2.1	[DEVICES]..... 23
5.2.2	[COMMISSIONING] 25
5.2.3	[FIRMWARE]..... 25
5.2.4	[MANAGEMENT]..... 26
5.3	COMMISSIONING PROCEDURE 32
6	MAINTENANCE..... 37
7	APPENDICES..... 38
7.1	APPENDIX A: TOOLS 38
7.2	APPENDIX B: RMA (RETURN MATERIAL AUTHORIZATION) FORM 39

0.2 INDEX TO FIGURES AND TABLES

Figure 1: Front, Side and Bottom Views of the PS BDA Enclosure	8
Figure 2: PS BDA Functional Block Diagram.....	9
Figure 3: Layout of the PS BDA	10
Figure 4: Mounting Rack Overview.....	15
Figure 5: PS BDA Wall Mounting.....	16
Figure 6: Equipment Connectors	17
Figure 7: OMT Connection without Opening Chassis.....	19
Figure 8: Input IP Address	22
Figure 9: Input Domain Name.....	22
Figure 10: Input User Name and Password.....	22
Figure 11: Web GUI Main Screen.....	23
Figure 12: Overview Screen.....	23
Figure 13: 800 Screen.....	24
Figure 14: 700 Screen.....	24
Figure 15: [Commissioning] Screen.....	25
Figure 16: [Firmware] Screen – MCU Firmware Upgrade	25
Figure 17: [Management] Screen	26
Figure 18: Management – Import & Export.....	26
Figure 19: Management – IP Setting	27
Figure 20: Management – Comm. Setting.....	27
Figure 21: New Site Report is for easy monitoring set up	28
Figure 22: Management – Security.....	28
Figure 23: Modify Password.....	29
Figure 24: Management – Device Reset	29
Figure 25: Management – Device Info.....	30
Figure 26: Management – Isolation	30
Figure 27: Management-Dry Contact.....	31
Figure 28: Management-Test.....	31
Figure 29: Management – Report.....	32
Figure 30: Commissioning Procedure - Start.....	32
Figure 31: Commissioning Procedure – Site Info. Setting	33
Figure 32: Dev Info & Date/Time	33
Figure 33: Commissioning Procedure – Isolation Detective	34
Figure 34: Commissioning Procedure – Isolation Detective Confirm	34
Figure 35: Commissioning Procedure –Isolation Detection Failed	34
Figure 36: Commissioning Procedure –Isolation Detection Finish	35
Figure 37: Commissioning Procedure – Center Frequency Setting	35
Figure 38: Commissioning Procedure – Finish	36
Table 1: Equipment Connectors	17
Table 2: LED Indicators.....	18
Table 3: Commissioning Task Explanation.....	21

0.3 HISTORY

Change No.	ENU	Details Of Change
1	1-0-0	This manual first created and issued in Apr. 2016.

0.4 GLOSSARY OF TERMS

Abbreviation	Definition
ALC	Automatic Level Control
ATT	Attenuator
BTS	Base Transceiver Station
CH	Channel
CSA	Cross Sectional Area
dB	Decibel
dBm	Decibels relative to 1 milliwatt
DL	Downlink
DT	Donor Terminal
DPX	Duplexer
FS	Frequency Selection
GSM	Global Standard for Mobile Communication
Hz	Hertz
ID	Identification
IF	Intermediate Frequency
LNA	Low Noise Amplifier
LOS	Line-of-Sight
MCU	Main Control Unit
MHz	Megahertz
MT	Mobile Terminal
MTBF	Mean Time Between Failures
NF	Noise Figure
OMC	Operation & Maintenance Center
OMT	Operation & Maintenance Terminal
PA	Power Amplifier
PLL	Phase Locked Loop
PSU	Power Supply Unit
RF	Radio Frequency
SIM	Subscriber Identification Module
SMA	Sub-Miniature A Connector
SMS	Short Message Service
UL	Uplink
VAC	Volts Alternating Current
VDC	Volts Direct Current
VSWR	Voltage Standing Wave Ratio

0.5 SAFETY NOTICES AND ADMONISHMENTS

This document contains safety notices in accordance with appropriate standards. In the interests of conformity with the territory standards for the country concerned, the equivalent territorial admonishments are also shown.

Any installation, adjustment, maintenance and repair of the equipment must only be carried out by trained, authorized personnel. At all times, personnel must comply with any safety notices and instructions.

Specific hazards are indicated by symbol labels on or near the affected parts of the equipment. The labels conform to international standards, are triangular in shape, and are colored black on a yellow background. An informative text label may accompany the symbol label.

Hazard labeling is supplemented by safety notices in the appropriate equipment manual. These notices contain additional information on the nature of the hazard and may also specify precautions.

Note: The grantee is not responsible for any changes or modifications not expressly approved by the party responsible for compliance. Such modifications could void the user's authority to operate the equipment.

For compliance with the general population RF exposure limits, each individual antenna used for this transmitter must be installed to provide a separation distance greater than 67.2cm or more from all persons during normal operation and must not be co-located with any other antenna for meeting RF exposure requirements.

Warning Notices:

These draw the attention of personnel to hazards that may cause death or injury to the operator or others. Examples of use are cases of high voltage, laser emission, toxic substances, point of high temperature, etc.

Alert:

These draw the attention of personnel to hazards that may cause damage to the equipment. An example of use is the case of static electricity hazard.

Caution notices may also be used in the handbook to draw attention to matters that do not constitute a risk of causing damage to the equipment but where there is a possibility of seriously impairing its performance, e.g. by mishandling or gross maladjustment. Warnings and Cautions within the main text do not incorporate labels and may be in shortened form.

Disconnection of the 2 RF connectors may cause damage to the equipment when power is on. The application antenna and RF cable are not provided. The antenna gain should not exceed 10 dBi.

End of Section

1 GENERAL INFORMATION

The RX-7W22 is a new digital dual band public safety repeater (hereafter referred to as PS BDA) designed to protect the lives of first responders and building occupants. Through the use of digital filtering technology (DSP), the RX-7W22 helps eliminate adjacent channel interference to allow band selectivity and support 700MHz and 800MHz rebanding. Up to two non-contiguous frequency bands can be simultaneously supported in each of the 700MHz and 800MHz Public Safety frequencies via web-based GUI, which provides versatility and total control to the user.

Main Features

- PS 700 and 800MHz
- Class A BDA, 32 channel per band
- Channel selective, software programmable
- Auto diagnostic
- Uplink squelch, per channel and per time slot
- User adjustable gain control, UL and DL independent per channel
- US and Canada 700MHz and 800MHz band compatible, software adjustable
- Easy commission and setup via Web-based GUI
- Weatherproof enclosure, IP65/NEMA4X
- Fully compliant with the 2010 NFPA 72 Code
- Competitive size and weight
- Alarming output to supervised circuits for: antenna failure, amplifier failure.

The following figure shows the enclosure of the PS BDA.

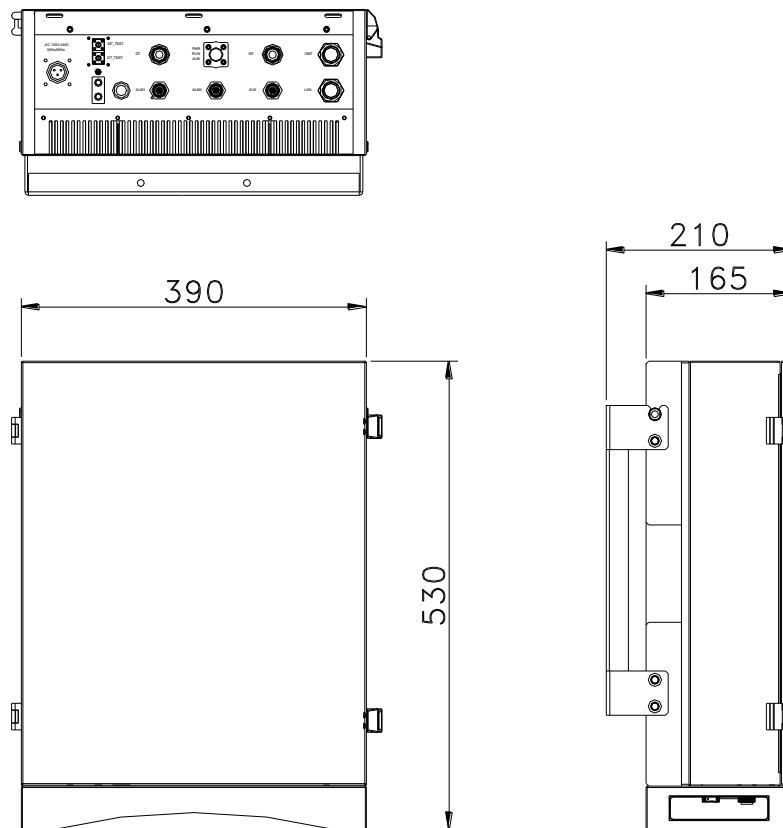

Figure 1: Front, Side and Bottom Views of the PS BDA Enclosure

2 EQUIPMENT DESCRIPTION

2.1 FUNCTIONAL BLOCK DIAGRAM

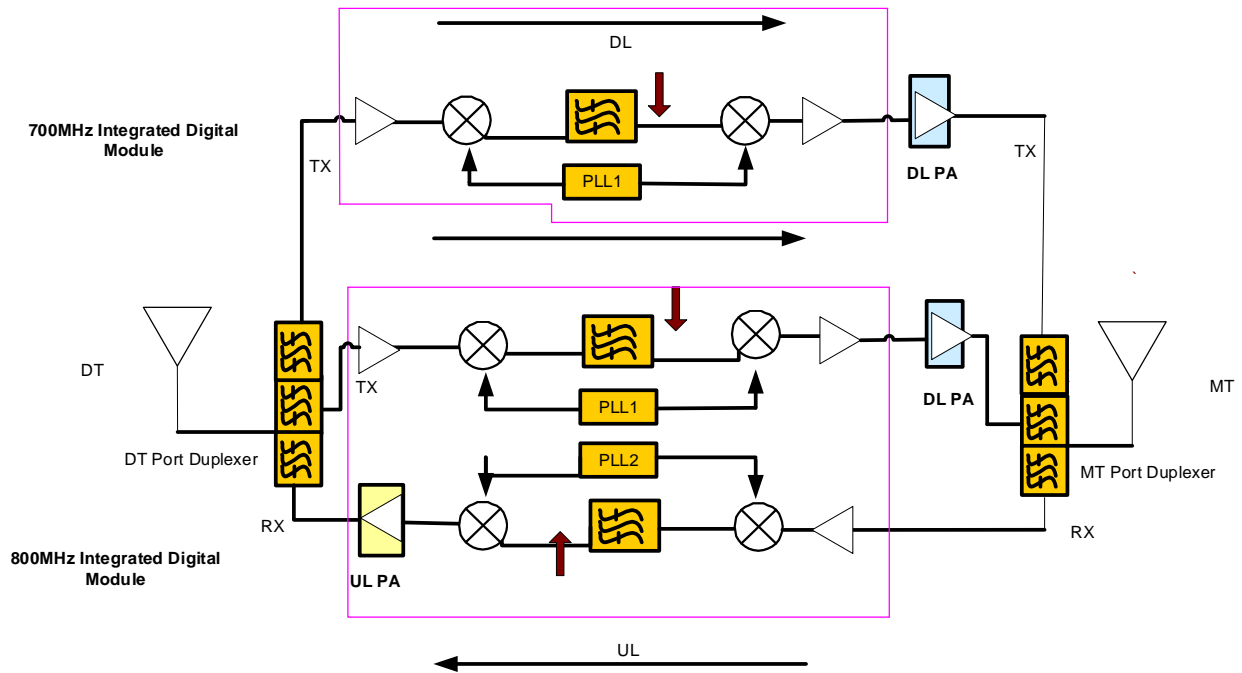

Figure 2: PS BDA Functional Block Diagram

In the downlink, the BTS signals are received by donor antenna of the repeater. After the duplexer, the signals are sent to the LNA module for pre-amplification and digital RF integrated module for digital filtering and frequency conversion. Then the DL signals will be sent to downlink PA to amplify power and filter via duplexer. After amplification, the signals are transmitted at the MT port to the service antenna.

In the uplink, the mobile signals are received by the service antenna. After the MT port integrated duplexer, the signals are sent to the LNA, integrated module for digital filtering, then to PA for power amplification and to duplexer. After that, the uplink signals are sent to the donor antenna for transmission back to the BTS.

2.2 EQUIPMENT LAYOUT

Shown below is the internal layout of the PS BDA.

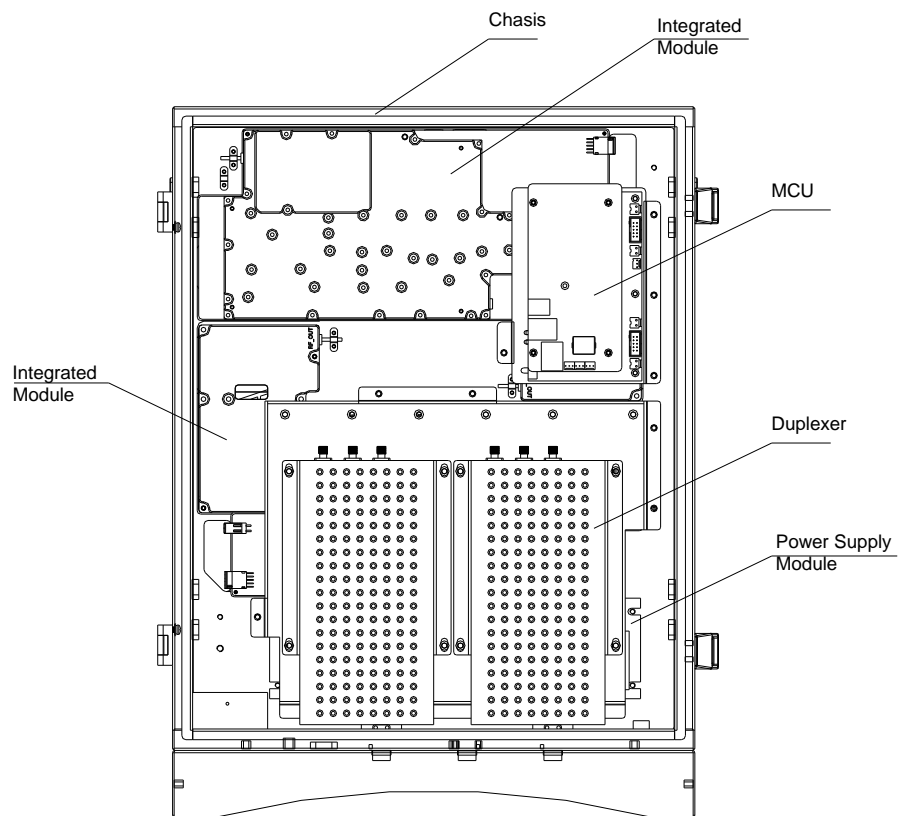

Figure 3: Layout of the PS BDA

2.3 EQUIPMENT CONSTITUTION

The typical PS BDA unit consists of the following components:

Power Amplifier (PA): It fulfils power amplification in both UL and DL branches.

Main Control Unit (MCU): The MCU is used to monitor and control the operation of the repeater. It also provides the communication interface for remote control and indication. LED indicators provide the operation status of the MCU.

Duplexer: The DPX is located towards the MT terminals and permits the uplink and downlink signals to share a common antenna.

Digital Integrated Module and Power Amplifier: Consists of Power Conversion module, RF module, digital process module and monitoring module. Power Conversion module converts +28V DC voltage in to +9VJK and +9VRF. +9VJK, +9VRF are supplied to monitoring unit and RF unit in integrated module separately. RF module amplifies and converts the RF signal to IF signal. Digital process module converts the IF signal into baseband signal via AD conversion and extraction, filtering. After that, IF signal will be amplified and converted to RF signal by RF module for RF filtering and amplification. Monitoring module monitors and controls the system parameters and is the interface of both remote monitoring and local commissioning.

Power Supply Unit (PSU): The PSU converts the input voltage into a stable DC to provide power for the internal functional modules.

3 INSTALLATION

3.1 WARNINGS AND ALERTS

Radio Frequency Energies

There may be situations, particularly for workplace environments near high-powered RF sources, where recommended limits for safe exposure of human beings to RF energy could be exceeded. In such cases, restrictive measures or actions may be necessary to ensure the safe use of RF energy.

High Voltage

The equipment has been designed and constructed to prevent, as far as reasonably, practicable danger. Any work activity on or near equipment involving installation, operation or maintenance must be, as far as reasonably, free from danger.

Where there is a risk of damage to electrical systems involving adverse weather, extreme temperatures, wet, corrosive or dirty conditions, flammable or explosive atmospheres, the system must be suitably installed to prevent danger.

Protective Earthing

Equipment provided for the purpose of protecting individuals from electrical risk must be suitable for the purpose and properly maintained and used.

Handling Precautions

This covers a range of activities including lifting, lowering, pushing, pulling, carrying, moving, holding or restraining an object, animal or person from the equipment. It also covers activities that require the use of force or effort, such as pulling a lever, or operating power tools.

Where some of the abovementioned activities are required, the equipment must be handled with care to avoid being damaged.

Electrostatic Discharge (ESD)

Observe standard precautions for handling ESD-sensitive devices. Assume that all solid-state electronic devices are ESD-sensitive. Ensure the use of a grounded wrist strap or equivalent while working with ESD-sensitive devices. Transport, store, and handle ESD-sensitive devices in static-safe environments.

3.2 SITE PLANNING CONSIDERATIONS

3.2.1 SITE PLANNING

Site Considerations

Outdoor equipment are designed to be waterproof, rainproof, and with snow protection. Temporary protection should be taken when the equipment enclosure is opened for installation or maintenance in an outdoor environment. The equipment must not be opened for installation or maintenance in bad weather (e.g. gale, storm rainfall, extreme temperatures and high humidity)

Installation Location

Mounting surface shall be capable of supporting the weight of the equipment.

In order to avoid electromagnetic interference, a proper mounting location must be selected to minimize interference from electromagnetic sources such as large electrical equipment.

Environmental

Humidity has an adverse effect on the reliability of the equipment. It is recommended to install the equipment in locations having stable temperature and unrestricted air-flow.

The installation location for the product should be well ventilated. The equipment has been designed to operate at the temperature range and humidity level as stated in the product specifications in the datasheet.

Direct sun light exposure to the equipment should be avoided. Provide additional shelter if necessary.

Power Supply

The power supply unit (PSU) provides power to all modules within the equipment. Depending on the product variant, it is recommended that the PSU operates on a dedicated circuit breaker or fused circuit.

Grounding Requirement

Verify that the equipment has been well grounded. This includes antennas and all cables connected to the system. Ensure lightning protection for the antennas is properly grounded.

Cable Routing

Depending on equipment configuration, a variety of types of cables are required. Where applicable, ensure cables are properly routed and secured so that they are not damaged.

Manual Handling

During transportation and installation, take necessary handling precautions to avoid potential physical injury to the installation personnel and the equipment.

3.2.2 INSTALLATION CHECKLIST

- Working space available for installation and maintenance for each mounting arrangement. Ensure unrestricted airflow.
- Ensure earthing point is within reach of the ground wire.
- Ensure a power source is within reach of the power cord and the power source has sufficient capacity.
- Where appropriate, ensure unused RF connectors are terminated.
- Do not locate the equipment near large transformers or motors that may cause electromagnetic interference.
- Reduce signal loss in feeder cable by minimizing the length and number of RF connections.
- Ensure VSWR of antennas system < 1.5:1.
- Ensure equipment will be operated within the stated environment (see datasheet)
- Observe handling of all cables to prevent damage.
- Donor antenna should have a narrow beamwidth and positioned in line-of-sight (LOS) to donor BTS site so that the donor signal level is maximized. This allows the use of minimum gain to achieve the maximum DL output power. The UL gain is typically set lower than or equal to the DL gain to minimize noise interference to the donor BTS
- Service antenna should be selected based on the type of service area, e.g., indoor antenna for indoor application, and panel antenna for outdoor application.

3.3 INSTALLATION PROCEDURES

3.3.1 GOODS INWARDS INSPECTION

- Verify the number of packages received against the packing list.
- Check all packages for external damage; report any external damage to the shipping courier. If there is damage, a shipping agent should be present before unpacking and inspecting the contents because damage during transit is the responsibility of the agent.
- Open and check each package against the packing list. If any items are missing, contact Comba.
- Do not remove items from anti-static packing until ready for installation. If damage is discovered at the time of installation, contact the shipping agent.

3.3.2 TOOLS

See Appendix A for a full list of the recommended tools required for installation and routine maintenance.

3.3.3 PREPARATION

- Wall mounting with the masonry bolts supplied, which make use of the outer holes.

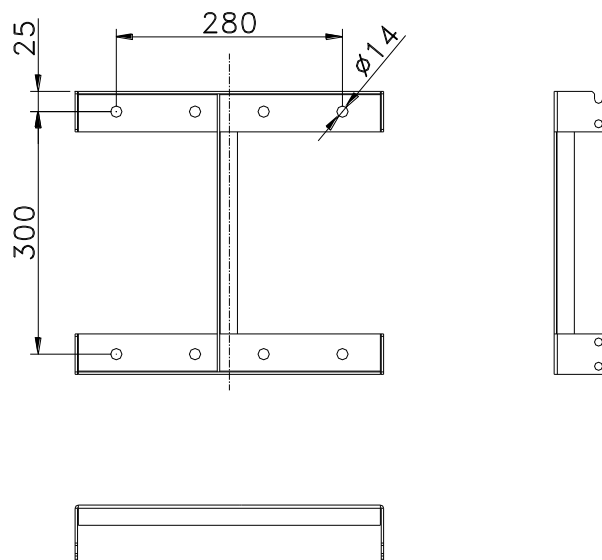

Figure 4: Mounting Rack Overview

3.3.4 WALL MOUNTING

- Drill four holes on the wall using the position of four holes on the mounting rack as a guide. Fix the mounting rack to the wall using four masonry bolts (M10x110mm).
- Install the Mounting Rack2 on the both side of the enclosure.
- Hang up the equipment and secure the enclosure to the mounting rack.

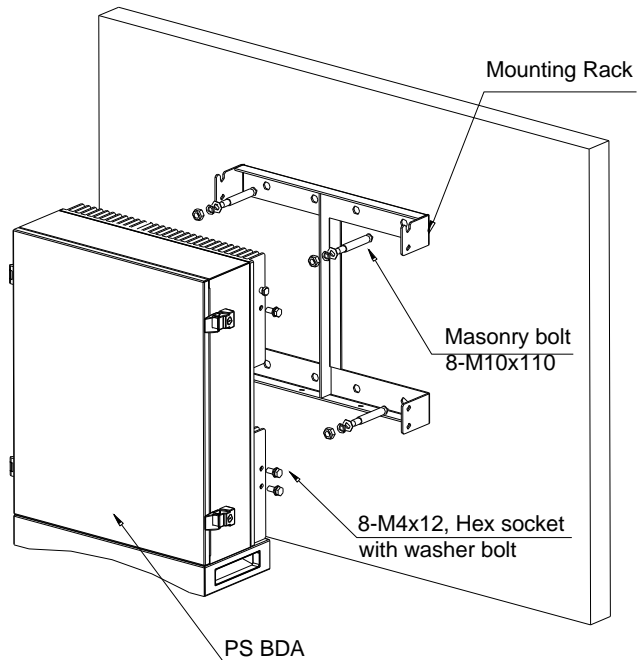

Figure 5: PS BDA Wall Mounting

3.3.5 DRIP-LOOP

Comba recommends that every horizontal cable entry to the equipment forms a 'U' before its entry to the equipment. Water on the cable will drip down at the bottom of the loop and will not accumulate at the equipment connectors.

3.4 EQUIPMENT CONNECTORS

3.4.1 PS BDA CONNECTORS

The PS BDA is designed for all cable entries from the right or left of the enclosure, as shown in the following figure.

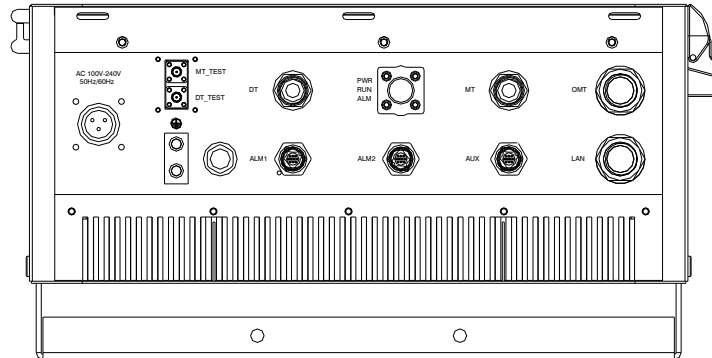

Figure 6: Equipment Connectors

Table 1: Equipment Connectors

Identifier	Descriptions
Power ¹	This is a power cable gland for a pre-installed power cord for connection to AC (e.g. AC 100-240V 50Hz/60Hz).
DT Test	QMA connector for connection to donor antenna test.
MT Test	QMA connector for connection to service antenna test.
DT	N-Female connector for connection to donor antenna.
MT	N-Female connector for connection to service antenna.
OMT	N-Female connector for OMT connection
ALM1	Mini-Din connector for connection to external alarm.
ALM2	Mini-Din connector for connection to external alarm.
AUX	Reserved.
LAN	RJ45 Connector for internet connection (Ethernet type only).

¹ The voltage identification is a variant due to electricity system diversity of global regions. The power cable gland might be identified for AC 110V, AC 220V, AC 110V/220V, or DC -48V respectively. Please refer to specific product or contact local sales if any doubt.

3.4.2 PS BDA LED INDICATORS

The LED indicators helps user to check the equipment status easily.

Table 2: LED Indicators

Identifier	Colour	Indication
PWR	Green	Power indicator. ON = power on; OFF = power off.
RUN	Green	Operation indicator, flashes every second to indicate normal operation.
ALM	Red	Alarm indicator. ON = alarm; OFF = no alarm.

3.4.3 GROUNDING CONNECTION

Ground Connection

To ensure safe operation of the product, a ground (earth) connection is required. For single phase AC power source, the product must be grounded by connecting the “earth wire” of the power cord to the ground terminal of the AC supply. For operating this product with DC power system (such as rectifiers), the product should not be connected to power systems that switch open the return lead because the return lead could function as the ground (earth) connection for the equipment.

Protective Ground Connection

The enclosure must be grounded securely by connecting a copper wire (CSA 16mm²) to the grounding terminal on the equipment/rack, and the other end to a protective ground (i.e. building earth point). An internationally acceptable colour code of the ground connection wire is green/yellow.

Such a ground connection implements the “Protective Ground Connection”, and must be connected to the equipment at the designated ground point. In general, do not connect the supply before establishing an adequate ground (earth) connection.

Construct the ground wire, and use appropriate crimp connectors where necessary. Locate and connect the equipment grounding terminal to a protective ground (i.e. building earth point).

3.4.4 RF CABLE CONNECTION

Single band PS BDA RF cables connection is as follows:

- PS BDA MT port → Connects to the feeder cable from service antenna.
- PS BDA DT port → Connects to the feeder cable from donor antenna.

3.4.5 ETHERNET CONNECTION

Connect Ethernet with ‘LAN’ port in the panel, Ethernet type only.

3.4.6 PHYSICAL CONNECTION TO OMT PC

For local commissioning, user can take figure below as a guide to connect the equipment with OMT PC.

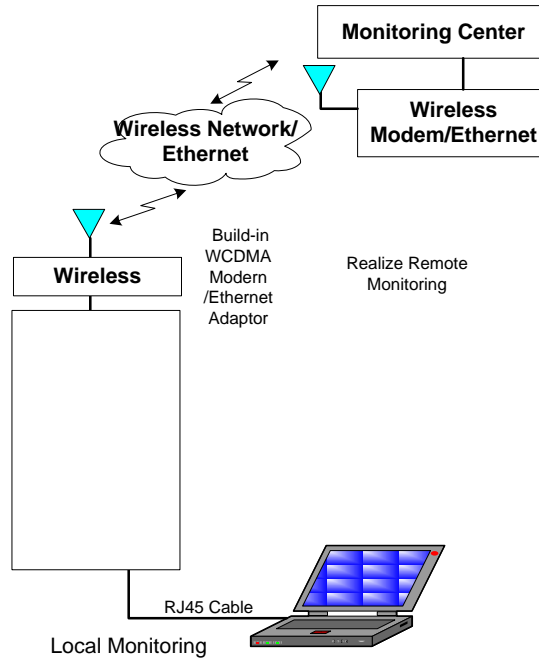

Figure 7: OMT Connection without Opening Chassis

Note: After connection and commissioning, please make sure the water proof for all external connectors.

End of Section

4 COMMISSIONING

4.1 PRE-COMMISSIONING TASKS

After equipment installation, perform the following steps before equipment powering and commissioning:

- Check the expected voltage, current and power levels do not violate any ratings.
- Visually inspect the power connection within the equipment. Ensure that the power cable is correctly and securely connected, including grounding wire, RF cable and other cables.
- Check grounding connection and verify that the ground resistance is less than 5Ω.
- Test the antenna system and ensure the echo loss within working frequency is less than -14dB (VSWR<1.5).

4.2 COMMISSIONING PROCEDURE

Perform the following procedures for system commissioning.

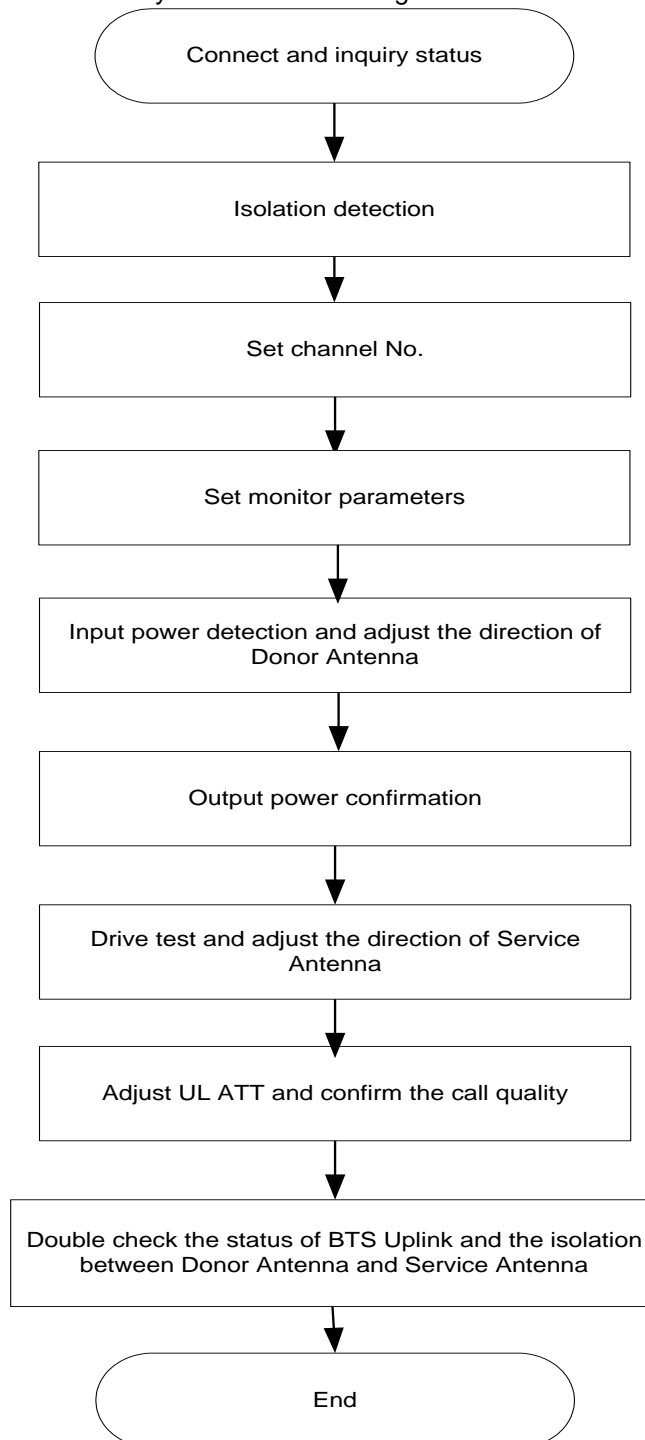

Table 3: Commissioning Task Explanation

Commissioning Tasks	Observation
1. On-line and Inquiry status	<ul style="list-style-type: none"> ● Activate the OMT Main window. The system Initialization will completed in about 2 minutes. ● Check the ALM LED for the repeater's status. Proceed if there is no alarm; else check the failure and attend to the alarm.
2. Isolation detection	<ul style="list-style-type: none"> ● Detect isolation of service antenna and donor antenna.
3. Set Channel No.	<ul style="list-style-type: none"> ● Keep RF switch ON and set the channel number of the repeater's operating frequency.
4. Adjust Downlink Output Power and align donor antenna	<ul style="list-style-type: none"> ● Observe DL input power from measured value. Align the direction of donor antenna until the DL input power reading is maximized. ● Note: To ensure that the measured DL input power is accurate, one should set the DL ATT to "0" before performing the check.
5. Configure [Device ID]	<ul style="list-style-type: none"> ● Go to [Device Info] and set [Device ID].
6. Comm. Setting	<ul style="list-style-type: none"> ● Go to [Management] -> [Comm. Setting] and select communication types: [SMS], [PS] or [SNMP].
7. Select Monitoring Parameters	<ul style="list-style-type: none"> ● Select the equipment controlled and monitored parameters..
8. Test coverage area field intensity and adjust service antenna.	<ul style="list-style-type: none"> ● Use test-handset to verify field intensity within the coverage area. If needed, realign the service antenna to achieve the desired coverage. ● Note: If during operation, the equipment gain could not be set to maximum or the output power is not high enough due to insufficient donor and service antennas isolation, then the antennas' position should be changed to increase isolation. If the output power is too high and ALC is activated, then adjust the DL ATT to achieve optimal DL Gain.
9. Verify UL gain and ensure test call produces good voice quality and there is no interfering BTS	<ul style="list-style-type: none"> ● Adjust UL gain and perform test calls. Typically, the UL gain is set around 5dB less than DL gain. Perform test calls in the coverage area while adjusting UL gain if required. ● Note: If the repeater is near the BTS and the test call performance is poor, this may be due to UL noise interference to the BTS. Users can calculate and determine if the repeater UL noise will interfere with the BTS. ● Verify again that there is no unacceptable interference to BTS.

End of Section

5 WEB GUI

PS BDA can be monitored and controlled by WEB GUI, take descriptions below as a guide to finish system parameter setting and commissioning.

5.1 WEB GUI CONNECTION

Step 1: Connect OMT port to PC RJ45 port with the supplied RJ45 cable to set up a physical connection.

Step 2: Open browser (browser IE7.0, IE8.0, Chrome or Firefox, suggest display resolution is 1024x768), input Web GUI **IP address: 192.168.8.101**, click [Enter].

NOTE: DHCP and DNS are also available to login Web GUI. The domain name is: www.combaomt.com.

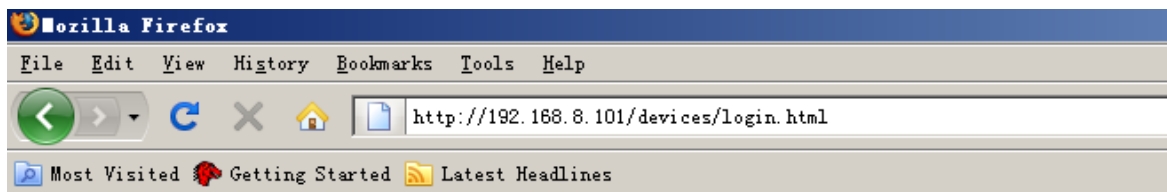

Figure 8: Input IP Address

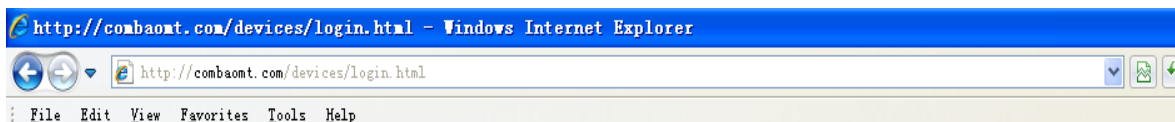

Figure 9: Input Domain Name

Step 3: Input **User Name: admin**; **Password** (default password: **admin**). Click [Log in].



Figure 10: Input User Name and Password

5.2 WEB GUI INTRODUCTION

After log in, the Web GUI main screen will appear.

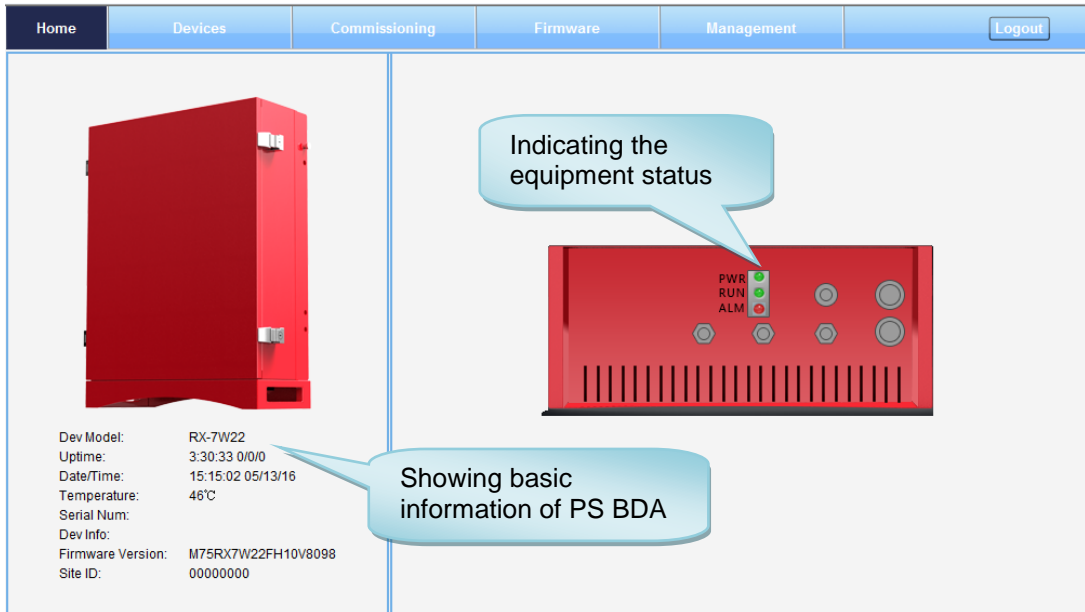

Figure 11: Web GUI Main Screen

On Comba Web GUI Home Screen, there are four Menu bars: **[Devices]**, **[Commissioning]**, **[Firmware]** and **[Management]**.

5.2.1 [DEVICES]

The [Devices] Screen shows the equipment status, such as PA status, alarm information, etc.

Overview Screen

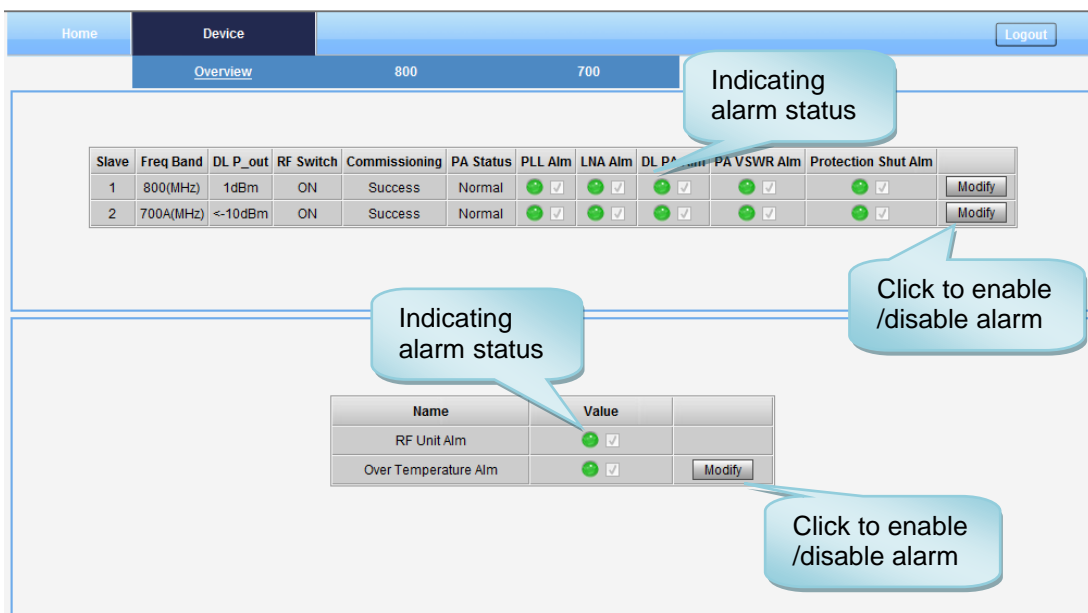

Figure 12: Overview Screen

800 Screen

This screen is only available for the dual band PS BDA or 800MHz PS BDA.

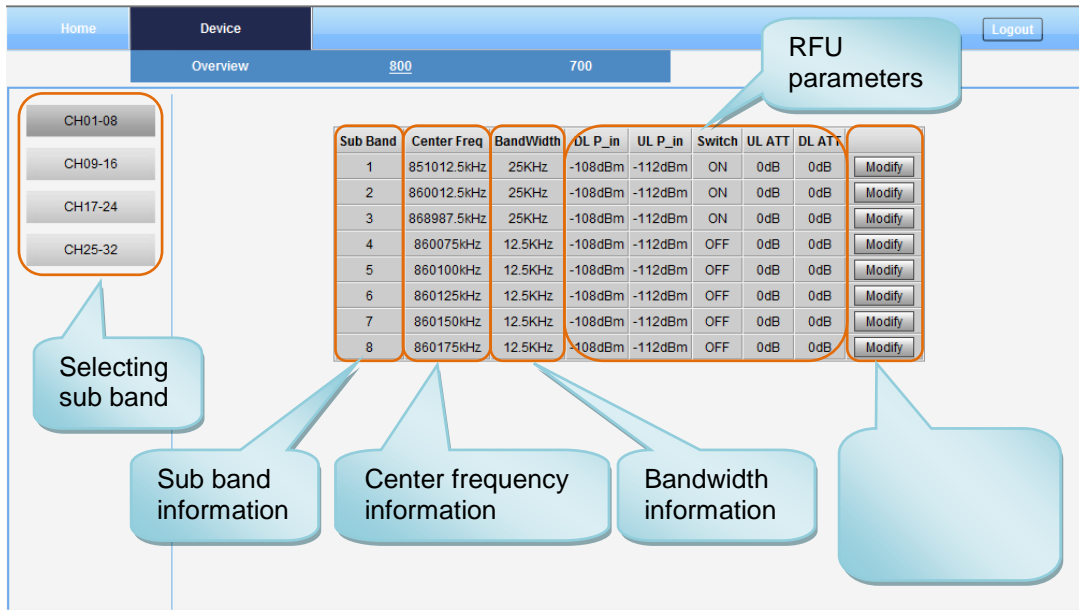

Figure 13: 800 Screen

700 Screen

This screen is only available for the dual band PS BDA or 700MHz PS BDA.

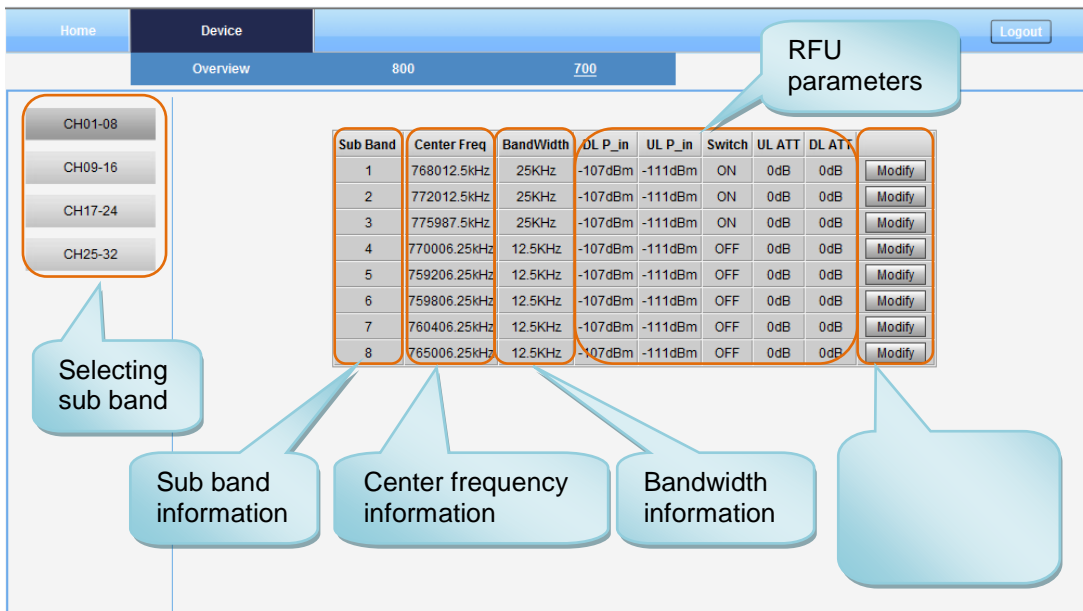

Figure 14: 700 Screen

5.2.2 [COMMISSIONING]

A work flow of the commissioning process is shown on [Commissioning] Screen. Click the [Start] button, the software will guide you through the commissioning step by step. For details, please refer to chapter 5.3.

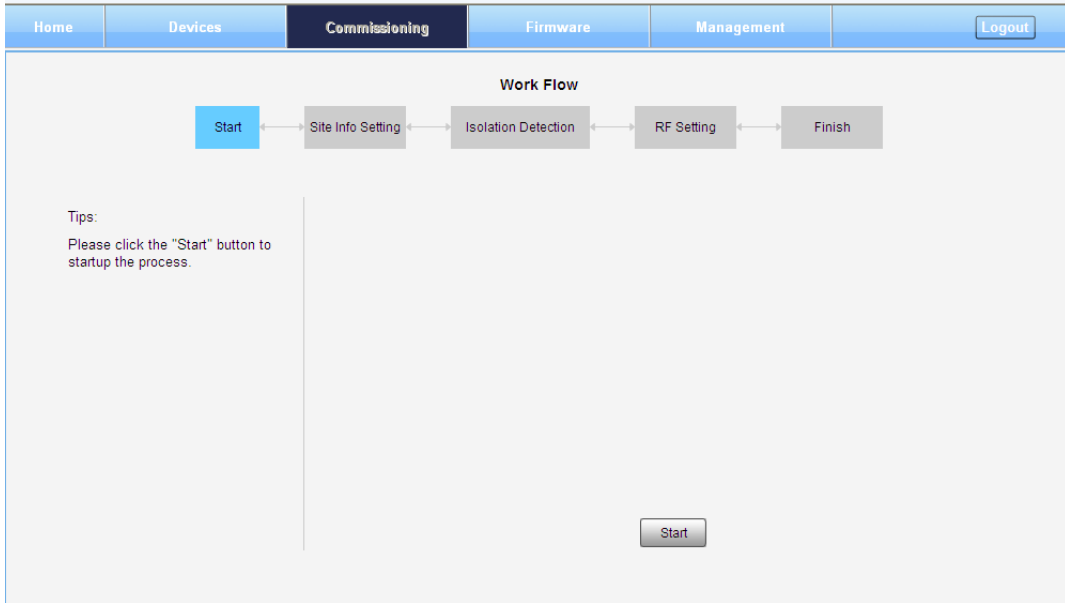

Figure 15: [Commissioning] Screen

5.2.3 [FIRMWARE]

There are two functions on the [Firmware] bar: [upgrade] and [swap]. [Upgrade] is used to upgrade software, and [Swap] is to replace current firmware version to the previous one.

Follow steps shown in below figure to upgrade firmware.

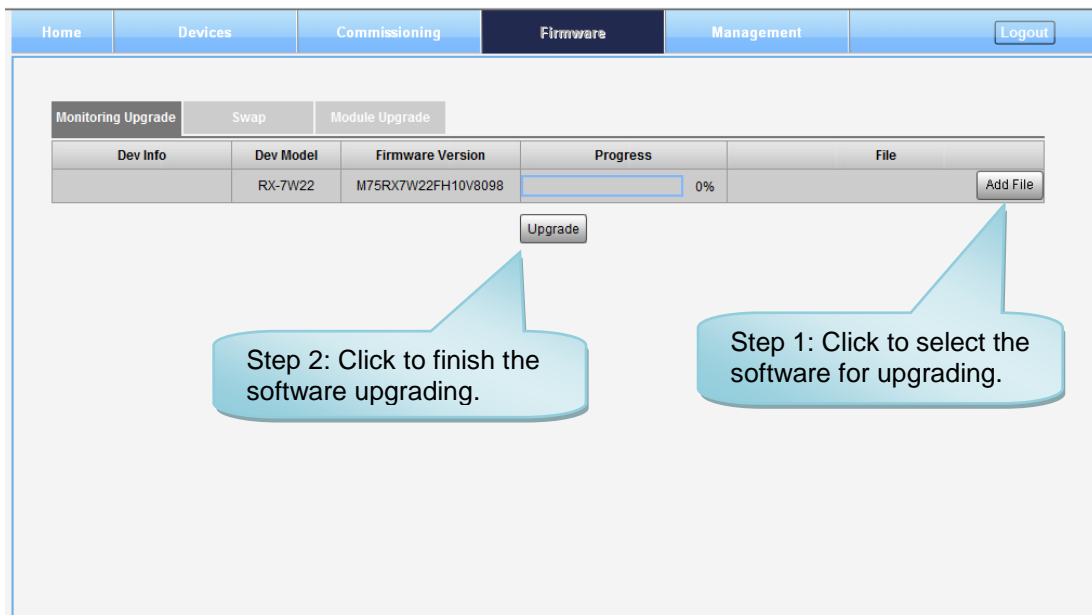

Figure 16: [Firmware] Screen – MCU Firmware Upgrade

5.2.4 [MANAGEMENT]

Other parameters can be configured on [Management] Screen.

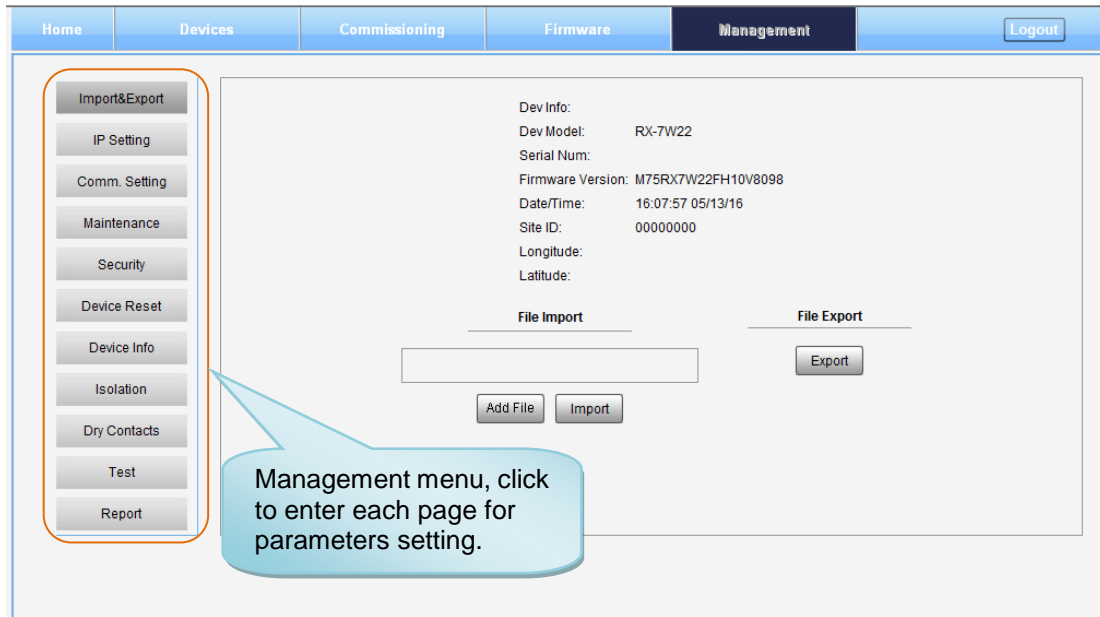

Figure 17: [Management] Screen

There are nine function bars list on the left side of the [Mangement] Screen.

➤ **Import&Export**

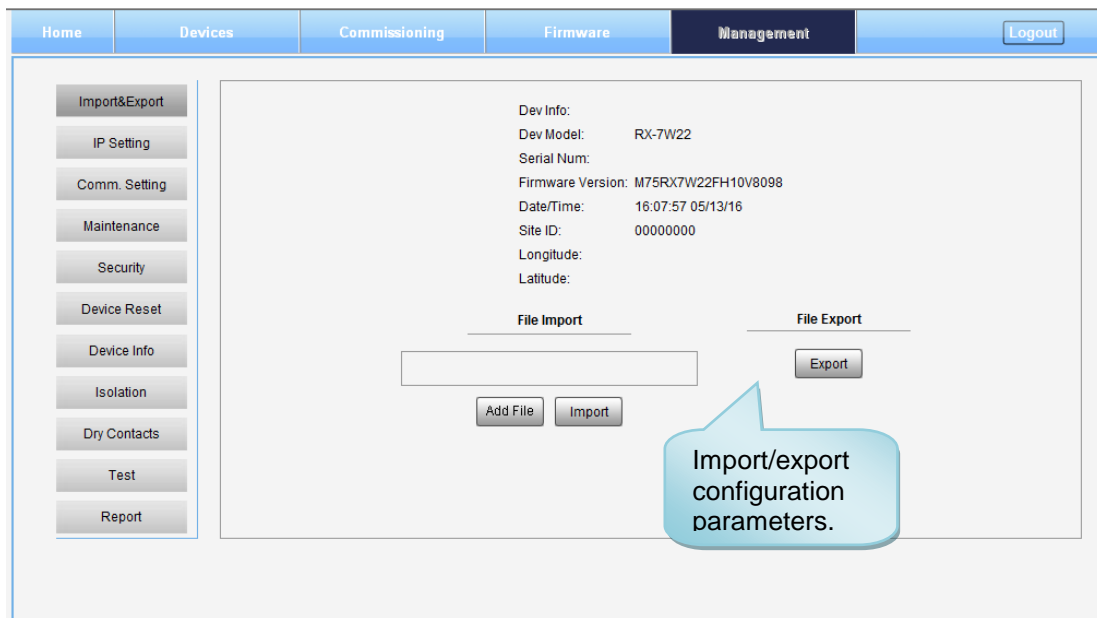

Figure 18: Management – Import & Export

The parameters that can be import/export include sub band, alarm enable, ATT value, RF switch, DL output power and so on.

This function can help users quickly configure PS BDA parameters. For example, if one PS BDA finished configuration, users can export the parameters and save it as a file in PC, and then import this file to other PS BDA to finish the device parameter setting in an easy way.

➤ IP Setting

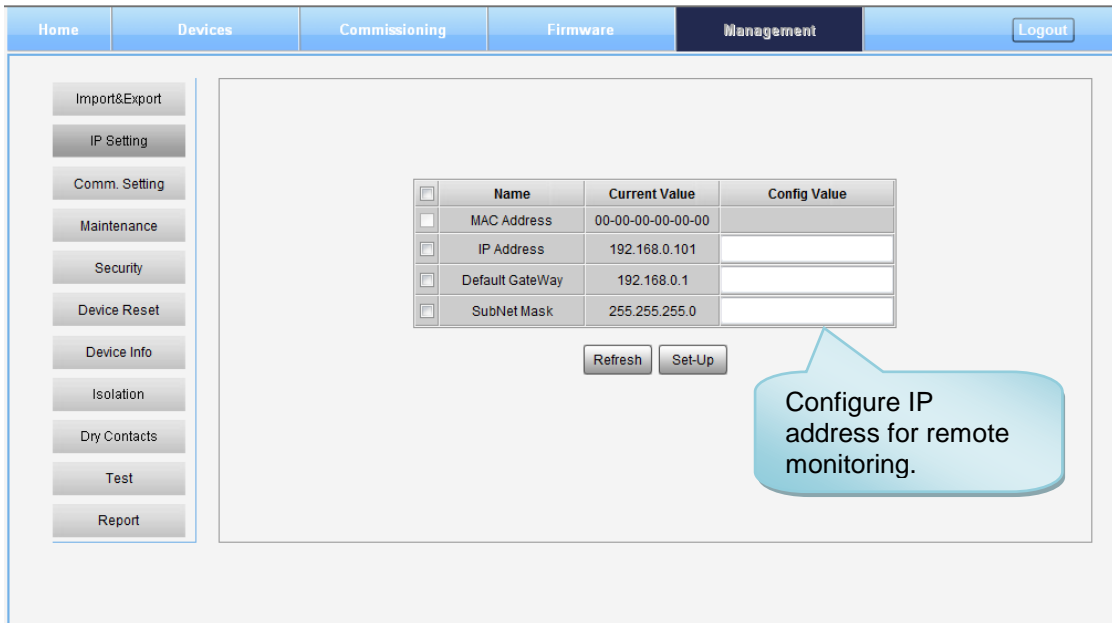

Figure 19: Management – IP Setting

Note: For remote monitoring, IP Address must be set correctly based on the location IP of remote connection. If more than one equipment is connected to the public network through the same router, the router’s local IP **CANNOT** be set as 192.168.8.*.

➤ Comm. Setting

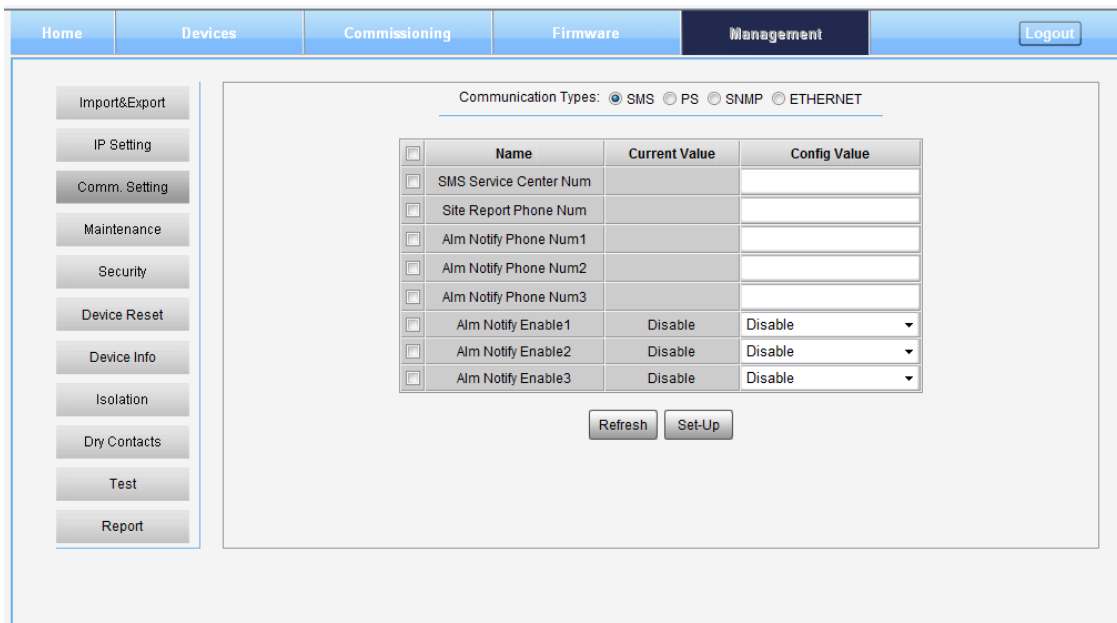

Figure 20: Management – Comm. Setting

Note: There are 4 communication types: SMS, PS, SNMP and ETHERNET. You can choose a suitable type for remote monitoring.

➤ Maintenance

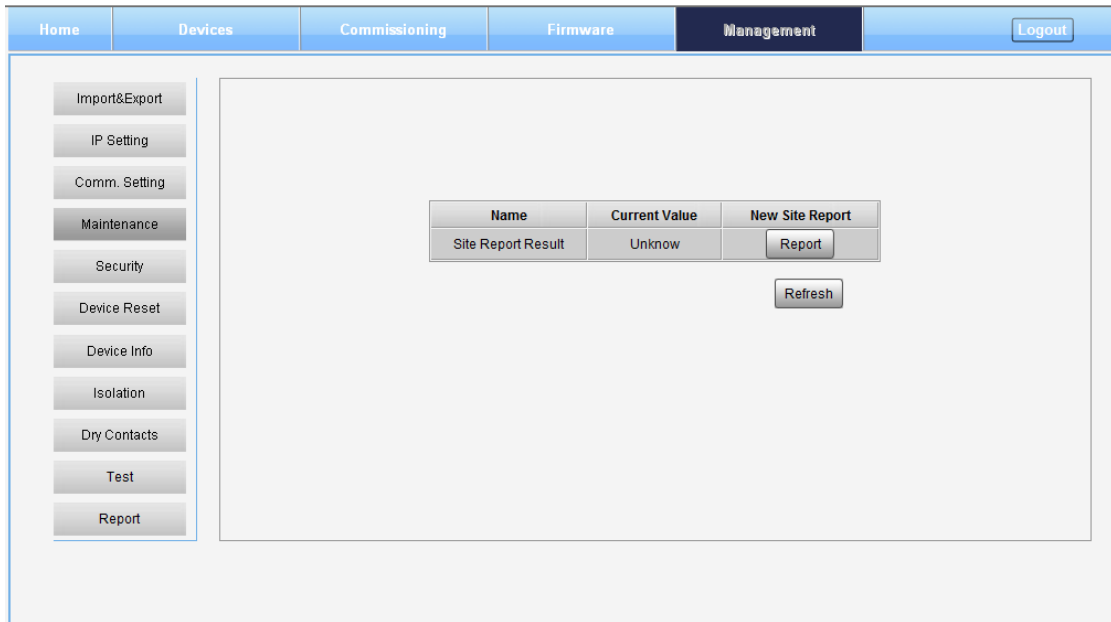

Figure 21: New Site Report is for easy monitoring set up

➤ Security

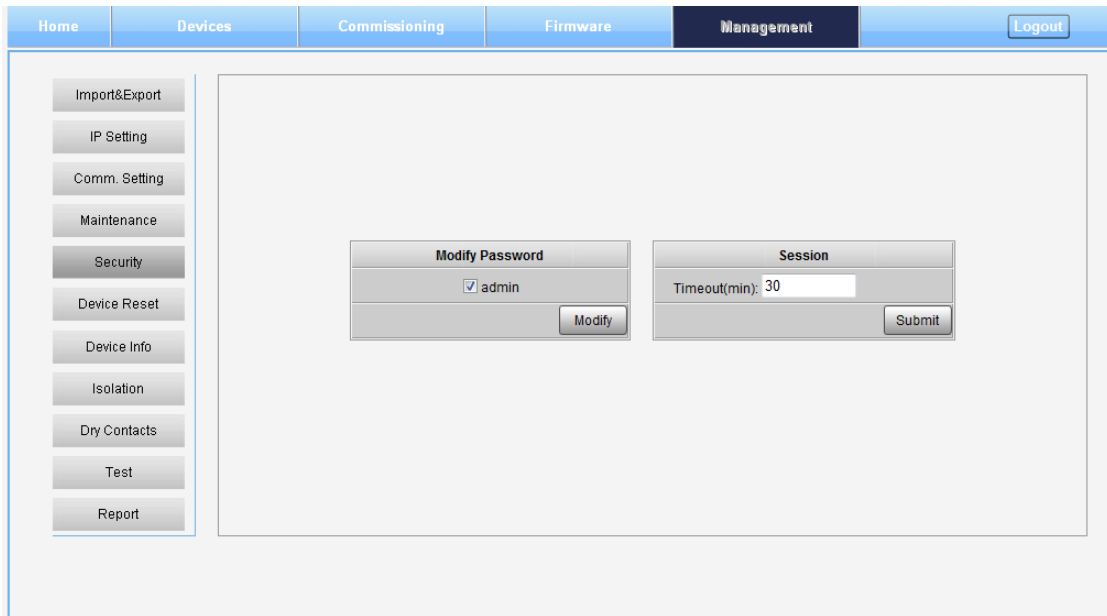

Figure 22: Management – Security

Click , [Modify Password] window will pop-up.

Figure 23: Modify Password

Note: Username cannot be modified.

➤ **Device Reset**

Freq Band	PA Reset
800(MHz)	Reset
700(MHz)	Reset

Figure 24: Management – Device Reset

Note: Click , all the parameter and alarm will set to factory default value. Device Reset process will last about 2~4 minutes. For PMU monitor reset, users need to re-login WEB GUI.

➤ Device Info

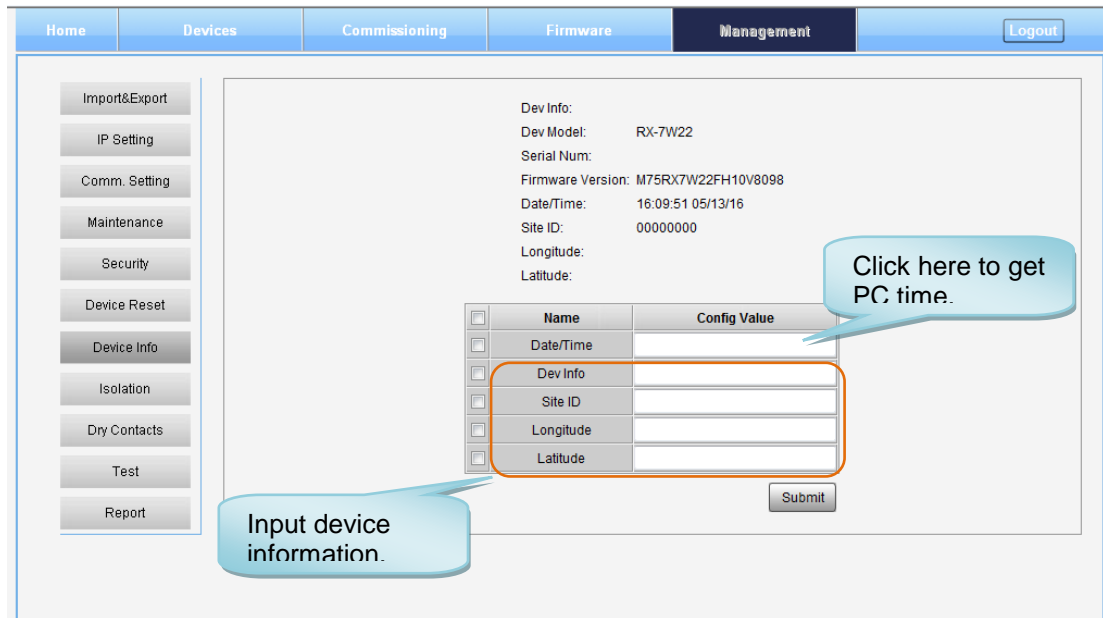

Figure 25: Management – Device Info

Note: Users can input maximum 30 bytes characters in Device Info.

➤ Isolation

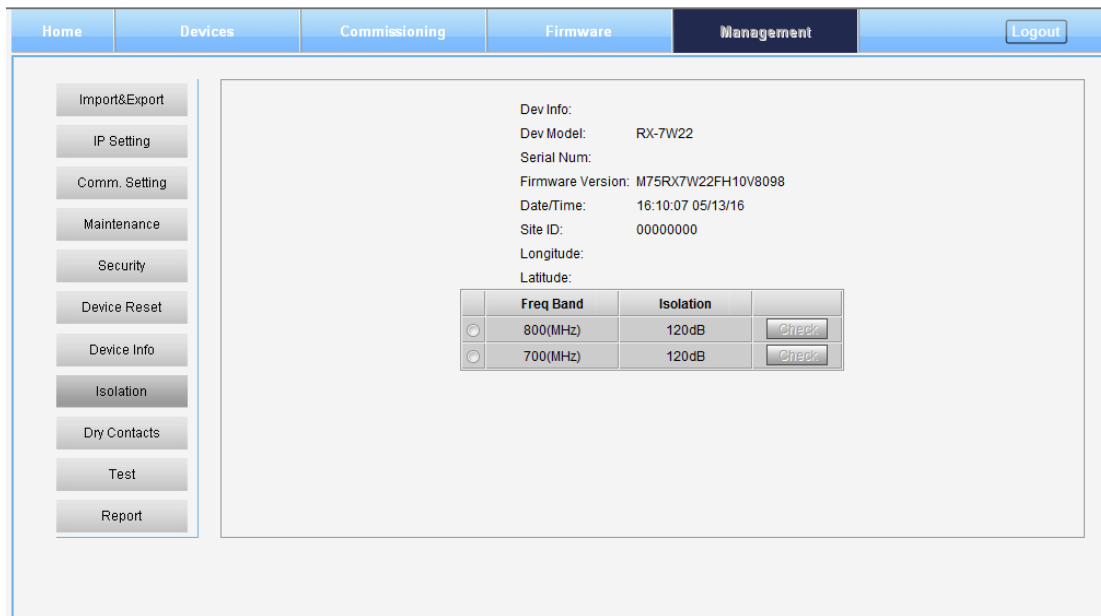

Figure 26: Management – Isolation

Note: This Step is the same as step3 of [Commissioning]. Users can check isolation again by clicking Check button.

➤ **Dry Contact**

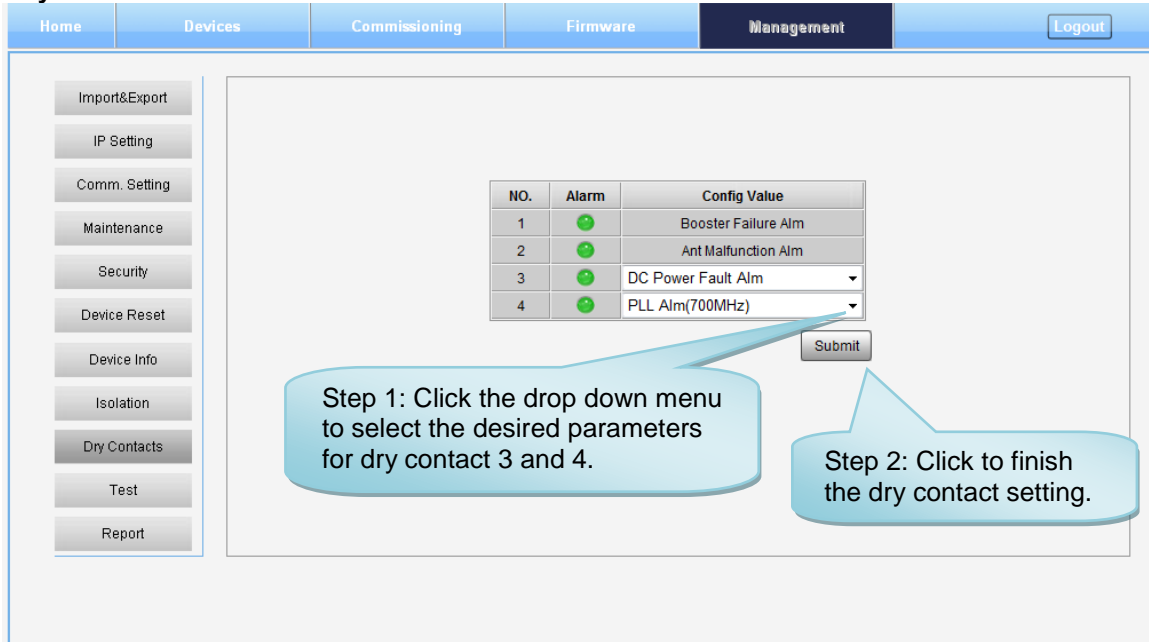

Figure 27: Management-Dry Contact

➤ **Test**

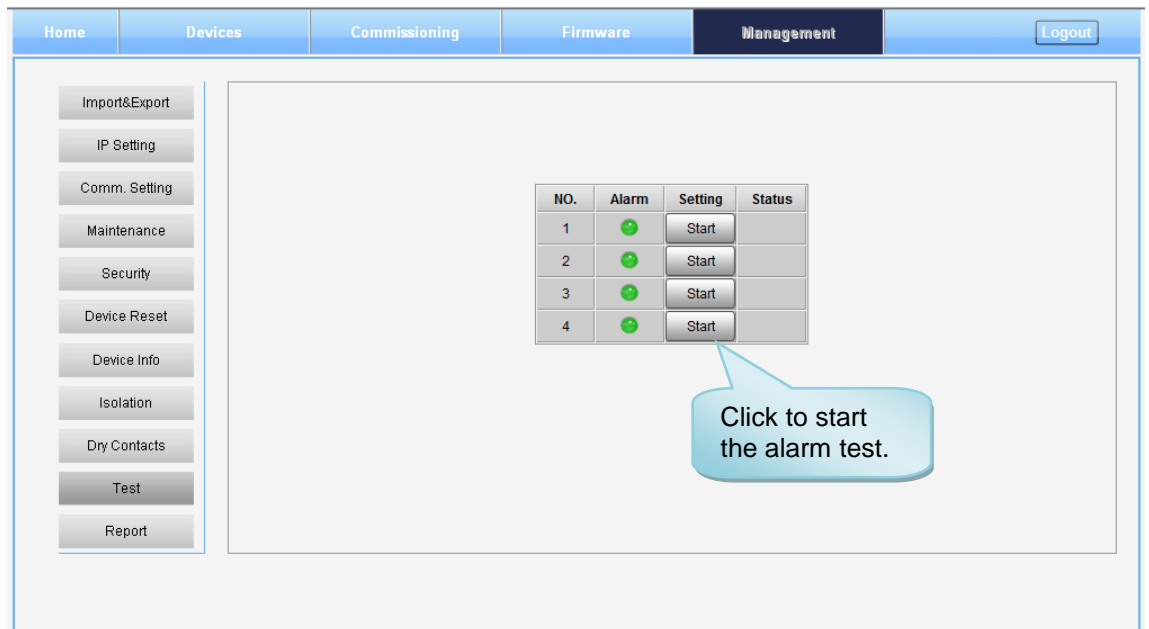

Figure 28: Management-Test

➤ Report

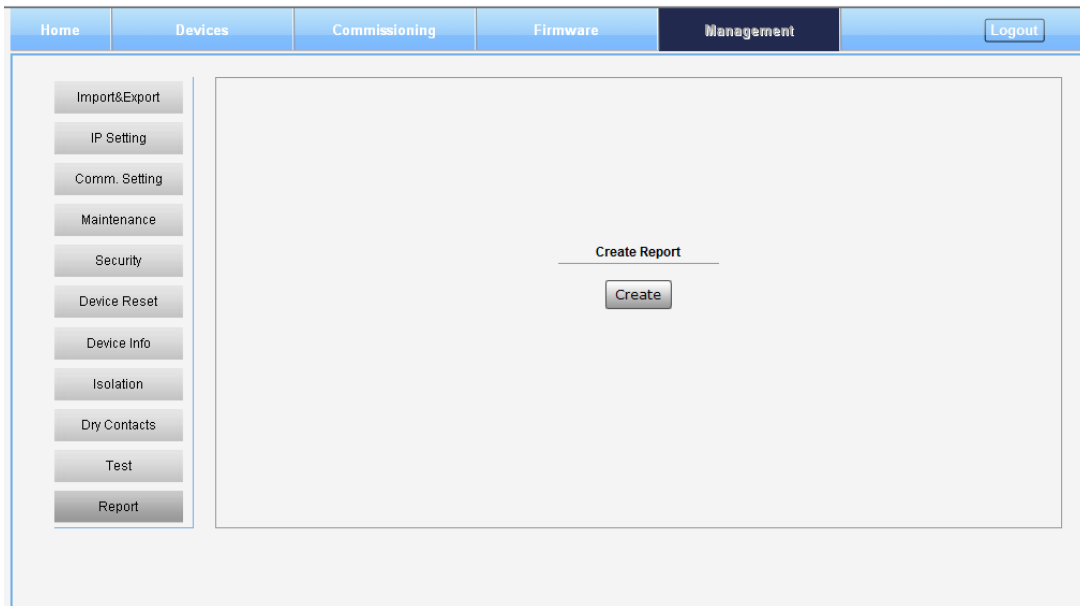

Figure 29: Management – Report

Note: Click Create to create report (The report can't create in IE browser.) and make sure the computer has installed PDF Reader software. If no, users will see nothing.

5.3 COMMISSIONING PROCEDURE

To complete the installation and commissioning, users need to follow the steps below.

Step 1: Click Menu bar [Commissioning] on home screen, a work flow will show up.

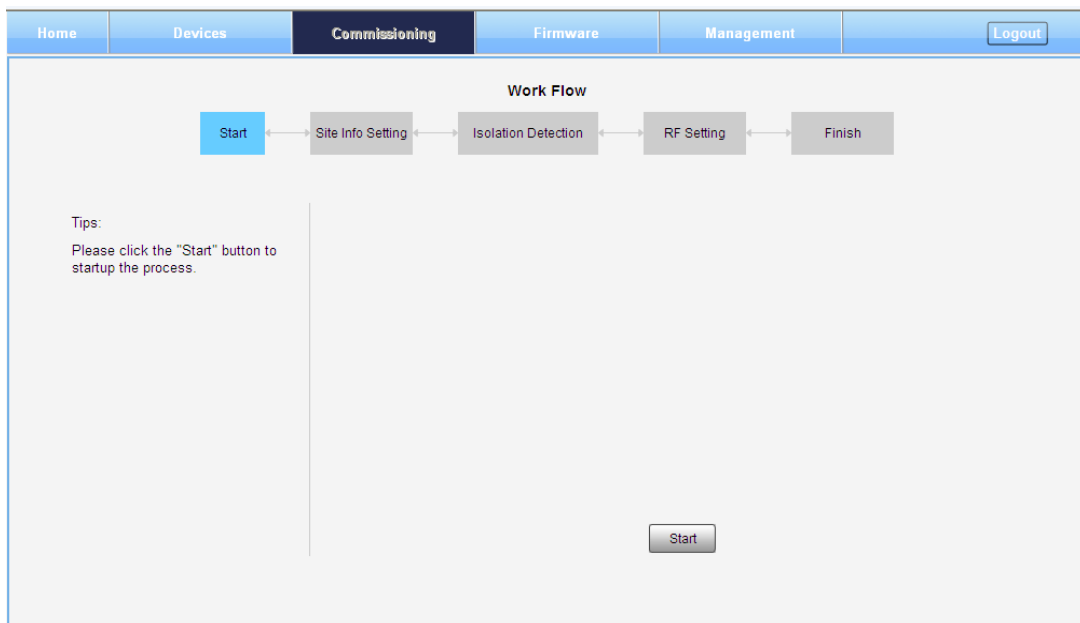

Figure 30: Commissioning Procedure - Start

Step 2: Click  to start the process.

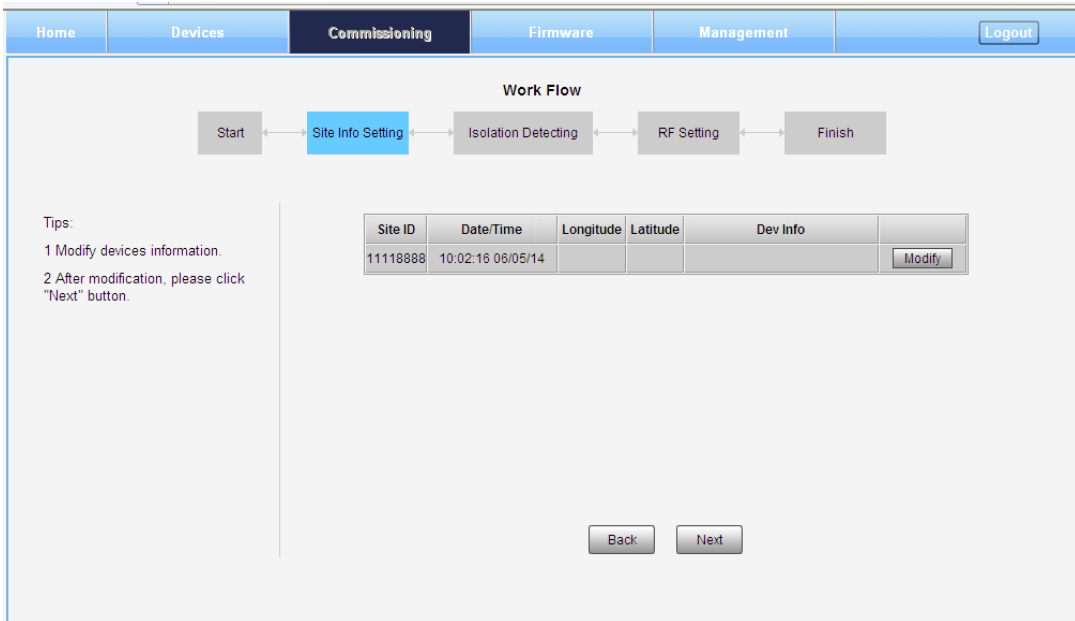



Figure 31: Commissioning Procedure – Site Info. Setting

Step 3: Click , users can set the site information.

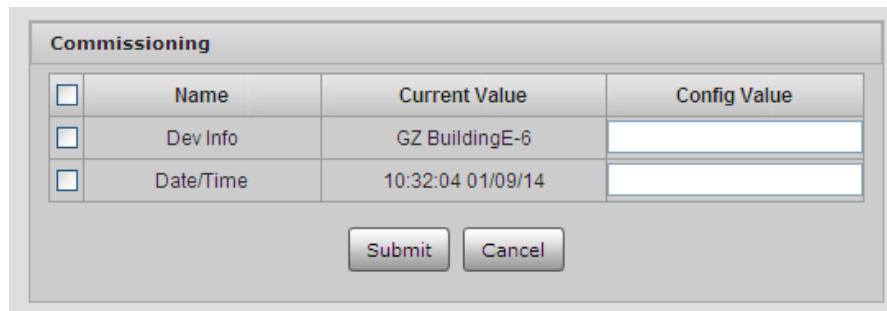



Figure 32: Dev Info & Date/Time

Dev Info mainly used to record device location and Date/Time provides a time reference. Click the Config Value of Date/Time, will update Date/time automatically.

NOTE: Make sure the device is connected with appropriate donor and service antennas before proceeding to step 4.

Step 4: Click  to enter to Isolation Detection Screen shown as Figure 52.

- ✓ Select a frequency band (RFU) that need to commission.
- ✓ Click  to start Isolation Detecting, then [Confirm] window will pop-up shown as Figure 53.

- ✓ Click **Ok** to continue. If isolation detection success, the process will go to RF Setting Screen shown as Figure 55. If failed, a Tips window will pop-up shown as Figure 54, users need to check whether the system isolation is very weak.

NOTE: At the end of first frequency band commissioning, user can start other frequency band commission.

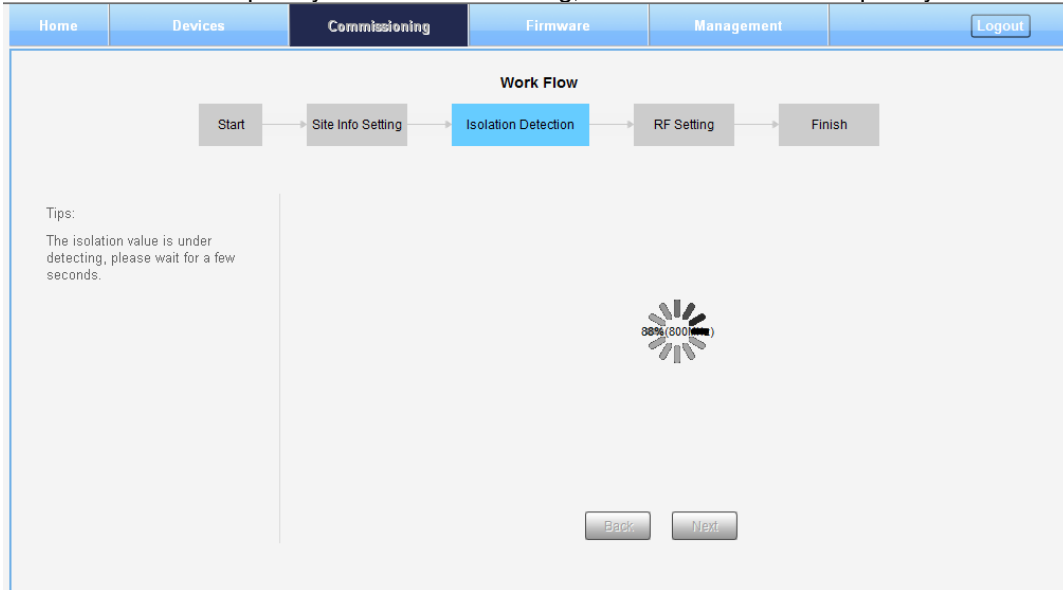

Figure 33: Commissioning Procedure – Isolation Detective

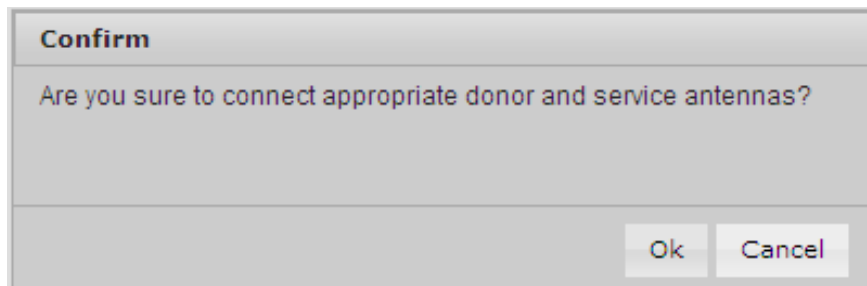

Figure 34: Commissioning Procedure – Isolation Detective Confirm

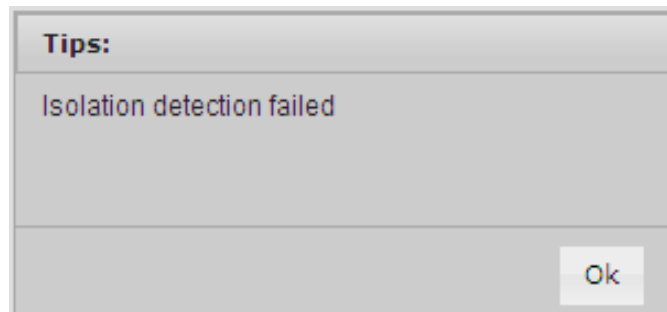

Figure 35: Commissioning Procedure –Isolation Detection Failed

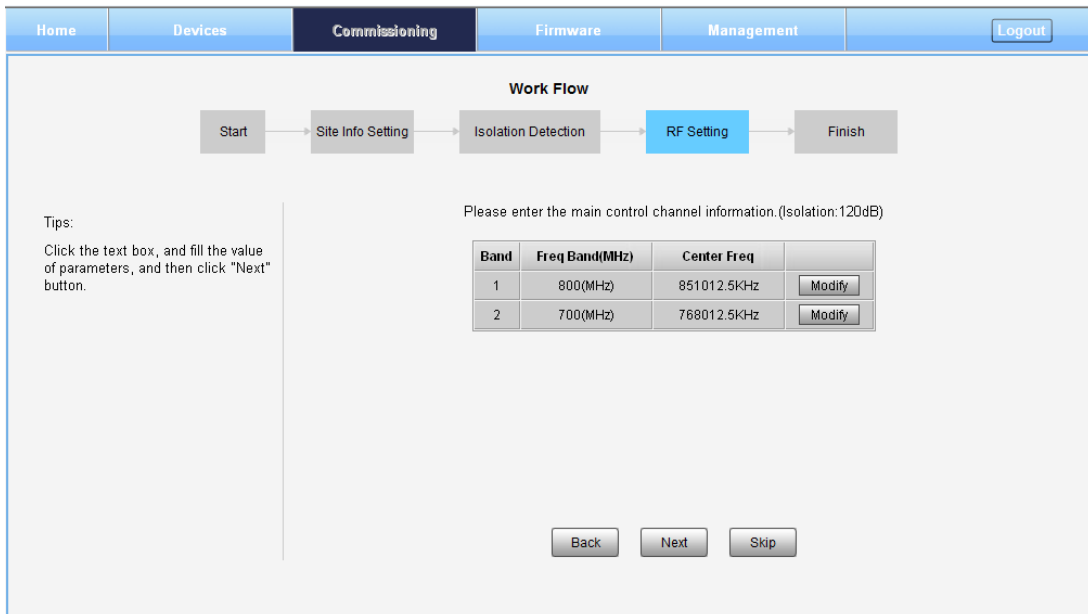

Figure 36: Commissioning Procedure –Isolation Detection Finish

Step 5: RF Setting Screen for setting center frequency.

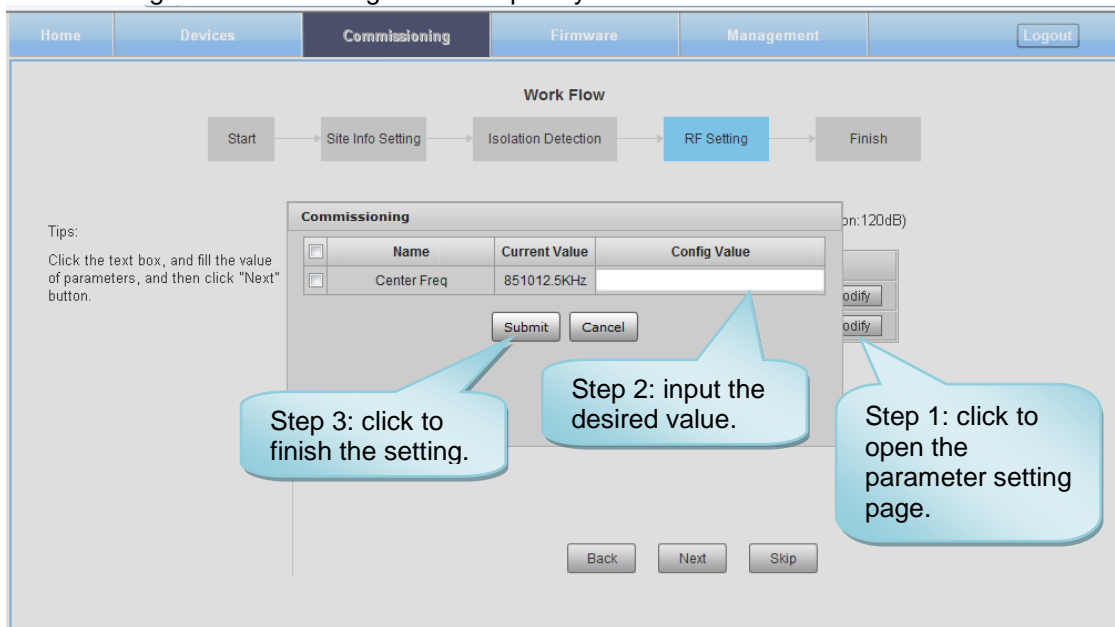



Figure 37: Commissioning Procedure – Center Frequency Setting

Step 7: Click  to finish the commissioning.

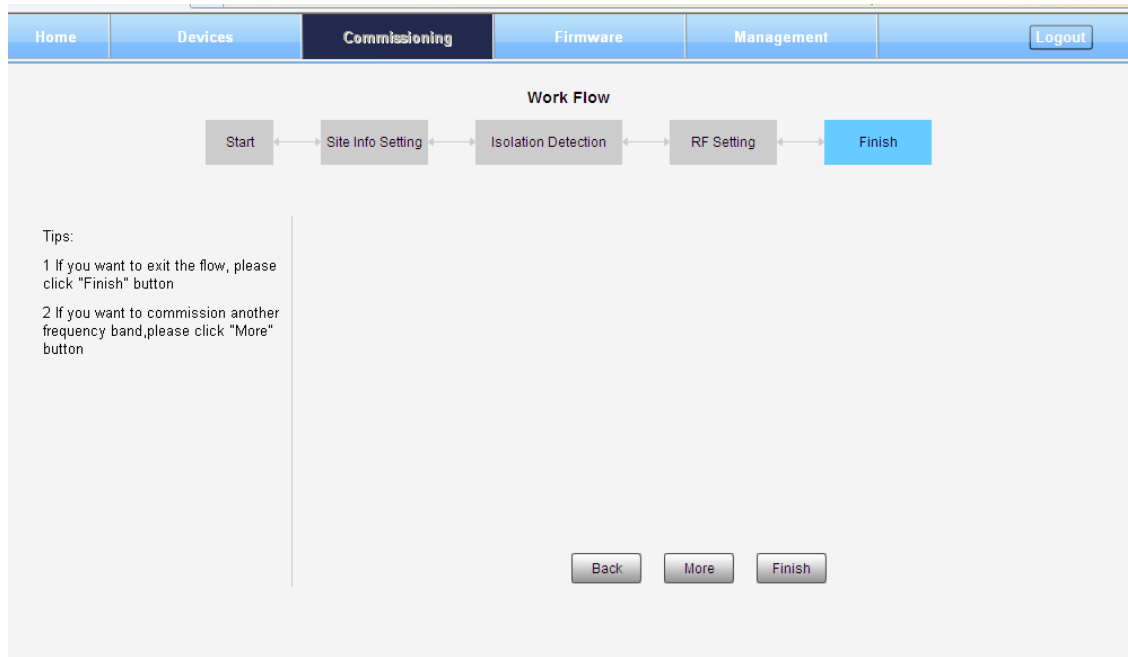

Figure 38: Commissioning Procedure – Finish

End of Section

6 MAINTENANCE

The mBDA is designed for trouble-free operation and generally does not need maintenance. Maintenance activities should only be carried out by trained personnel.

The equipment operation status can be observed remotely through OMC.

Periodic inspection of the repeater equipment(s) is recommended, the recommended tasks includes:

- Inspect and record operation status and output power of the repeater from OMC or OMT.
- Verify the direction and position of antennas. Re-align if necessary.
- Make sure the cable gland and sealing on the RF cable connectors are not damaged.
- Verify lightning and grounding protection is in good condition.

End of Section

7 APPENDICES

7.1 APPENDIX A: TOOLS

The following are the recommended list of tools for new installation and routine maintenance.

- Slotted Screwdriver
- Philips Screwdriver
- Ring Spanner (Assorted size: 12~20mm)
- Electrically operated drill and masonry drill bits \varnothing 12mm
- Anti-static Wrist Strap
- Pentagon Allen Key
- Side Cutter
- Frequency Counter (e.g. FLUKE PM6685R)
- RF Power Meter (e.g. Bird 5000)

7.2 APPENDIX B: RMA (RETURN MATERIAL AUTHORIZATION) FORM



Comba Telecom Ltd.
 611 East Wing, No. 8 Science Park West Avenue, Hong Kong Science Park, Tai Po, Hong Kong
 Tel: +852 2636 6861 Fax: +852 2637 0966

RMA Request Form
 Date: _____

From: _____
 Address: _____
 Tel: _____ Fax: _____
 E-Mail: _____
 ATTN: _____

Product Information:

Item	Model	Serial Number	Return Category	Qty	Problem Description
1					
2					
3					
4					
5					
6					
7					
8					
9					
10					

Notes:
 1. For 'Return Category' column, please select from **A:** Return of Defective Product, **B:** Return of Trial Sample, or **C:** Return of New and Unused Product.
 2. If **A** or **C** category of return product is chosen, please give short description of the problem or reason for returning.

Transportation Information:
 Location of Product: _____
 Transportation Method: _____
 Shipping Forwarder: _____

Note: Location of Product' must be stated, while 'Transportation Method' or 'Shipping Forwarder' can be left blank if not determined.

Signature:

For Comba Use (Only)
 Return Merchandise Authorization Number (RMA#): _____
 Recommended Action:
 Shipment and Handling Cost to be paid by: _____

Approved by: _____
 Date: _____

End of Section

End of Document



Corporate Headquarters

Comba Telecom Systems Holdings Ltd

Add: 611 East Wing, No.8 Science Park West Avenue, Hong Kong Science Park, Hong Kong

Tel: +852 2636 6861

Fax: +852 2637 0966 / +852 2116 6055

China Headquarters

Comba Telecom Systems China Ltd

Add: No.10 Shenzhou Road, Guangzhou Science City, China

Tel: +8620 2839 0000

Fax: +8620 2839 0136

www.comba-telecom.com