

**Comba**

**CriticalPoint Public Safety BDA**

# **DIGITAL BAND SELECTIVE REPEATER**

**USER MANUAL**

**Public Safety BDA SERIES QE: 1-0-0**

**Comba Telecom Ltd.**

**The information contained herein is the responsibility of and is approved by the following, to whom all enquiries should be directed:**

**This is an unpublished work the copyright in which vests in Comba International ("Comba"). All rights reserved.**

**The information contained herein is confidential and the property of Comba and is supplied without liability for errors or omissions. No part may be reproduced, disclosed or used except as authorized by contract or other written permission. The copyright and the foregoing restriction on reproduction and use extend to all media in which the information may be embodied.**

## 0.1 CONTENTS

Section	Page
0.1	CONTENTS ..... 4
0.2	INDEX TO FIGURES AND TABLES ..... 6
0.3	HISTORY ..... 7
0.4	GLOSSARY OF TERMS ..... 8
0.5	SAFETY NOTICES AND ADMONISHMENTS ..... 9
1	GENERAL INFORMATION ..... 10
2	EQUIPMENT DESCRIPTION ..... 12
2.1	FUNCTIONAL BLOCK DIAGRAM ..... 12
2.2	EQUIPMENT LAYOUT ..... 13
2.3	EQUIPMENT CONSTITUTION ..... 14
3	INSTALLATION ..... 15
3.1	WARNINGS AND ALERTS ..... 15
3.2	SITE PLANNING CONSIDERATIONS ..... 16
3.2.1	SITE PLANNING ..... 16
3.2.2	INSTALLATION CHECKLIST ..... 17
3.3	INSTALLATION PROCEDURES ..... 18
3.3.1	GOODS INWARDS INSPECTION ..... 18
3.3.2	TOOLS ..... 18
3.3.3	PREPARATION ..... 18
3.3.4	WALL MOUNTING ..... 19
3.3.5	DRIP-LOOP ..... 19
3.4	EQUIPMENT CONNECTORS ..... 20
3.4.1	PS BDA CONNECTORS ..... 20
3.4.2	PS BDA LED Indicators ..... 21
3.4.3	GROUNDING CONNECTION ..... 21
3.4.4	RF CABLE CONNECTION ..... 21
3.4.5	ETHERNET CONNECTION ..... 21
3.4.6	DRY CONTACT CABLE CONNECTION ..... 22
4	COMMISSIONING ..... 23
4.1	PRE-COMMISSIONING TASKS ..... 23
4.2	COMMISSIONING PROCEDURE ..... 24
5	WEB GUI ..... 26
5.1	WEB GUI CONNECTION ..... 26
5.2	WEB GUI INTRODUCTION ..... 27
5.2.1	[DEVICES] ..... 27
5.2.2	[COMMISSIONING] ..... 29
5.2.3	[FIRMWARE] ..... 30
5.2.4	[MANAGEMENT] ..... 31
5.3	COMMISSIONING PROCEDURE ..... 41
6	MAINTENANCE ..... 46
7	APPENDICES ..... 47
7.1	APPENDIX A: TOOLS ..... 47
7.2	APPENDIX B: DECLARATION OF HARMFUL SUBSTANCES AND CONTENT ..... 48

7.3	APPENDIX C: LICENSE SWITCH QUICK GUIDE .....	49
7.4	APPENDIX D: TROUBLESHOOTING QUICK GUIDE.....	51
7.5	APPENDIX E: DEVICE REPORT EXAMPLE .....	54
7.6	APPENDIX F: RMA (RETURN MATERIAL AUTHORIZATION) .....	55

**0.2 INDEX TO FIGURES AND TABLES**

Figure 1: Front, Side and Bottom Views of the PS BDA Enclosure..... 11

Figure 2: PS BDA Functional Block Diagram..... 12

Figure 3: Layout of the PS BDA ..... 13

Figure 4: Mounting Rack Overview ..... 18

Figure 5: PS BDA Wall Mounting ..... 19

Figure 6: Equipment Connectors ..... 20

Figure 8: Commissioning Procedure..... 24

Figure 9: Input IP Address ..... 26

Figure 10: Input Domain Name ..... 26

Figure 11: Input User Name and Password..... 26

Figure 12: Web GUI Main Screen ..... 27

Figure 13: Overview Screen..... 28

Figure 14: 800MHz Screen ..... 28

Figure 15: 700MHz Screen ..... 29

Figure 16: [Commissioning] Screen ..... 29

Figure 17: [Firmware] Screen – MCU Firmware Upgrade ..... 30

Figure 18: [Firmware] Screen – Firmware Swap ..... 30

Figure 19: [Firmware] Screen – Module Update ..... 31

Figure 20: [Management] Screen ..... 31

Figure 21: Management – Import & Export..... 32

Figure 22: Management – IP Setting ..... 33

Figure 23: Management – Comm. Setting ..... 34

Figure 24: New Site Report is for easy monitoring set up ..... 35

Figure 25: Management – Security..... 35

Figure 26: Modify Password..... 36

Figure 27: Management – Device Reset ..... 36

Figure 28: Management – License ..... 37

Figure 29: Management – Device Info..... 38

Figure 30: Management – Isolation ..... 38

Figure 31: Management – Dry Contact..... 39

Figure 32: Management – Test..... 39

Figure 33: Management – Report ..... 40

Figure 34: Commissioning Procedure – Start..... 41

Figure 35: Commissioning Procedure – Site Info. Setting ..... 41

Figure 36: Device Information Setting..... 42

Figure 37: Commissioning Procedure – Isolation Detection ..... 42

Figure 38: Commissioning Procedure – Isolation Detection Confirm ..... 43

Figure 39: Commissioning Procedure – Isolation Detection Failed ..... 43

Figure 40: Commissioning Procedure – Isolation Detection Finish ..... 44

Figure 41: Commissioning Procedure – Center Frequency Setting ..... 44

Figure 42: Commissioning Procedure – Channel Number Setting..... 45

Figure 43: Commissioning Procedure – Finish ..... 45

Figure 44: Input User Name and Password..... 49

Figure 45: Input License Code ..... 50

Figure 46: License switch success ..... 50

Figure 47: Alarm list ..... 51

Figure 48: Reset PA..... 52

Table 1: Equipment Connectors ..... 20

Table 2: LED Indicators..... 21

Table 3: Commissioning Task Explanation..... 25

### 0.3 HISTORY

Change No.	ENU	Details Of Change
1	1-0-0	This manual first created and issued in Aug. 2016.

## 0.4 GLOSSARY OF TERMS

Abbreviation	Definition
ALC	Automatic Level Control
ATT	Attenuator
BTS	Base Transceiver Station
CH	Channel
CSA	Cross Sectional Area
dB	Decibel
dBm	Decibels relative to 1 milliwatt
DL	Downlink
DT	Donor Terminal
DPX	Duplexer
FS	Frequency Selection
Hz	Hertz
ID	Identification
IF	Intermediate Frequency
LNA	Low Noise Amplifier
LOS	Line-of-Sight
MCU	Main Control Unit
MHz	Megahertz
MT	Mobile Terminal
MTBF	Mean Time Between Failures
NF	Noise Figure
OMC	Operation & Maintenance Center
OMT	Operation & Maintenance Terminal
PA	Power Amplifier
PLL	Phase Locked Loop
PSU	Power Supply Unit
RF	Radio Frequency
SMA	Sub-Miniature A Connector
UL	Uplink
VAC	Volts Alternating Current
VDC	Volts Direct Current
VSWR	Voltage Standing Wave Ratio

## 0.5 SAFETY NOTICES AND ADMONISHMENTS

This document contains safety notices in accordance with appropriate standards. In the interests of conformity with the territory standards for the country concerned, the equivalent territorial admonishments are also shown.

Any installation, adjustment, maintenance and repair of the equipment must only be carried out by trained, authorized personnel. At all times, personnel must comply with any safety notices and instructions.

Specific hazards are indicated by symbol labels on or near the affected parts of the equipment. The labels conform to international standards, are triangular in shape, and are colored black on a yellow background. An informative text label may accompany the symbol label.

Hazard labeling is supplemented by safety notices in the appropriate equipment manual. These notices contain additional information on the nature of the hazard and may also specify precautions.

**Note:** The grantee is not responsible for any changes or modifications not expressly approved by the party responsible for compliance. Such modifications could void the user's authority to operate the equipment.

For compliance with the general population RF exposure limits, each individual antenna used for this transmitter must be installed to provide a separation distance greater than 67.2cm or more from all persons during normal operation and must not be co-located with any other antenna for meeting RF exposure requirements.

### **Warning Notices:**

These draw the attention of personnel to hazards that may cause death or injury to the operator or others. Examples of use are cases of high voltage, laser emission, toxic substances, point of high temperature, etc.

### **Alert:**

These draw the attention of personnel to hazards that may cause damage to the equipment. An example of use is the case of static electricity hazard.

Caution notices may also be used in the handbook to draw attention to matters that do not constitute a risk of causing damage to the equipment but where there is a possibility of seriously impairing its performance, e.g. by mishandling or gross maladjustment. Warnings and Cautions within the main text do not incorporate labels and may be in shortened form.

Disconnection of the 2 RF connectors may cause damage to the equipment when power is on. The application antenna and RF cable are not provided. The antenna gain should not exceed 10 dBi and the shortest distance from human is 75 cm.

End of Section



## 1 GENERAL INFORMATION

The RX-7W22 is a new digital dual band public safety repeater (hereafter referred to as PS BDA) designed to protect the lives of first responders and building occupants. Through the use of digital filtering technology, the RX-7W22 helps eliminate adjacent channel interference to allow band selectivity and support 700MHz and 800MHz rebanding. Up to two non-contiguous frequency bands can be simultaneously supported in each of the 700MHz and 800MHz Public Safety frequencies via a web-based GUI, which provides versatility and total control to the user.

### Main Features

- PS 700MHz and 800MHz.
- Class A BDA, 32 channels per band.
- Channel selective, software programmable.
- Auto diagnostic.
- Uplink squelch, per channel.
- User adjustable gain control (AGC), UL and DL independent per channel.
- US and Canada 700MHz and 800MHz band compatible, software adjustable.
- Built in isolation testing (mandatory prior to commissioning the PS BDA).
- Easy commission and setup via Web-based GUI.
- Weatherproof enclosure, IP65/NEMA4.
- Fully compliant with the 2016 NFPA 72 Code.
- Competitive size and weight.
- Alarming output to supervised circuits for: antenna failure, signal booster failure, and etc.

The following figure shows the enclosure of the PS BDA.

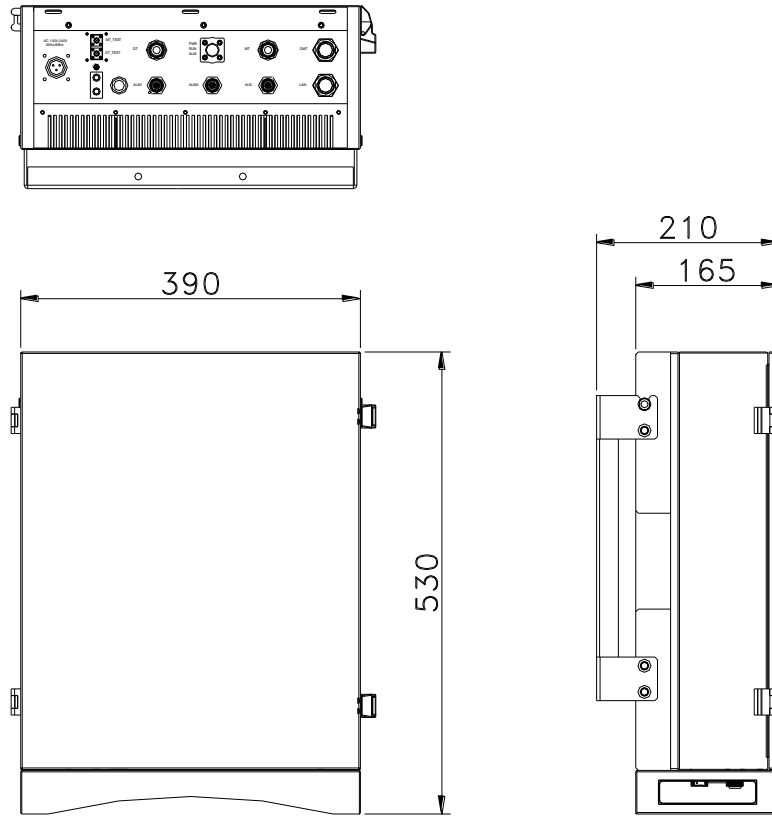

Figure 1: Front, Side and Bottom Views of the PS BDA Enclosure

## 2 EQUIPMENT DESCRIPTION

### 2.1 FUNCTIONAL BLOCK DIAGRAM

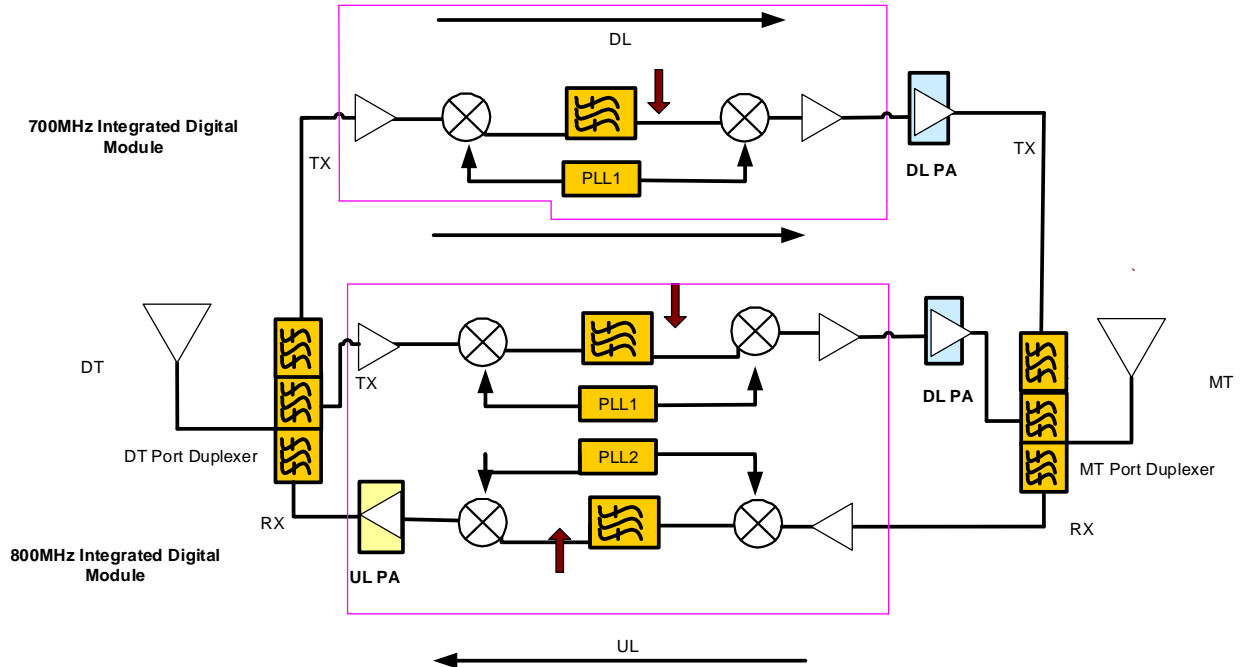

Figure 2: PS BDA Functional Block Diagram

In the downlink path, the BTS signals are received by the donor antenna of the repeater. After the duplexer, the signals are sent to the LNA module for pre-amplification and to the digital RF integrated module for digital filtering and frequency conversion. Then the DL signals will be sent to the downlink PA to amplify power, and filter via the duplexer. After amplification, the signals are transmitted at the MT port to the service antenna.

In the uplink path, the mobile signals are received by the service antenna. After the MT port integrated duplexer, the signals are sent to the LNA, integrated module for digital filtering, then to the PA for power amplification and to the duplexer. After that, the uplink signals are sent to the donor antenna for transmission back to the BTS.

## 2.2 EQUIPMENT LAYOUT

Shown below is the internal layout of the PS BDA.

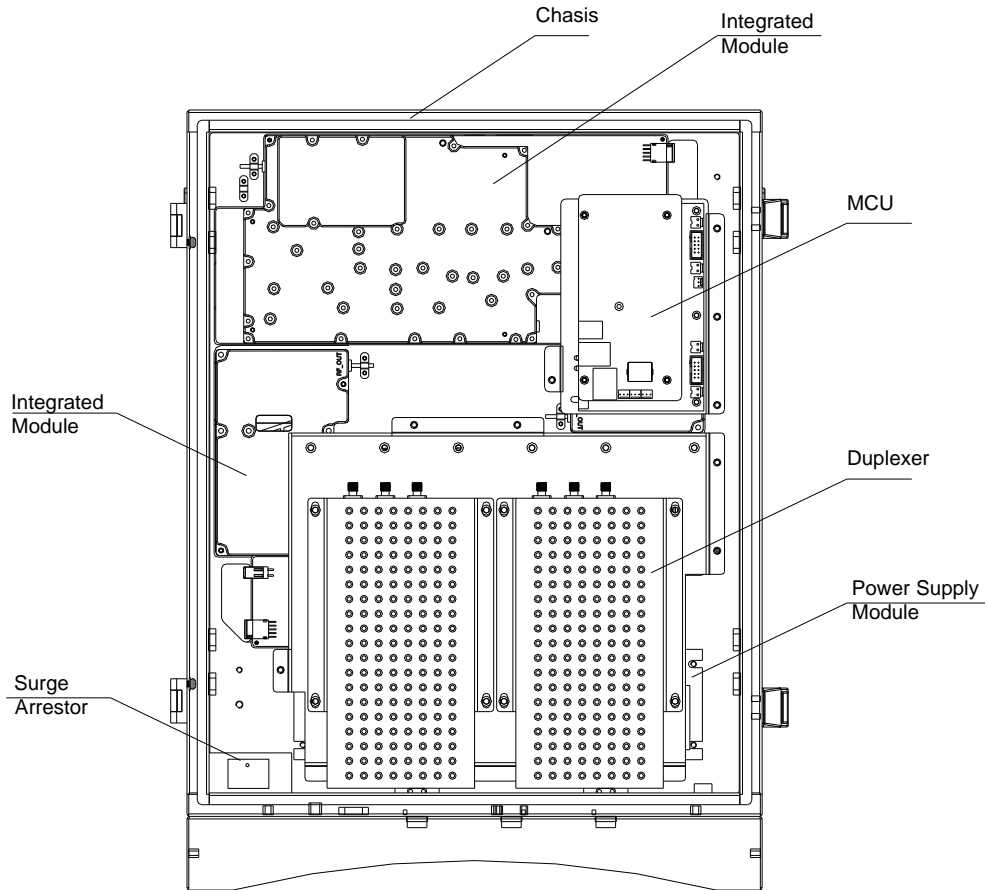

Figure 3: Layout of the PS BDA

## 2.3 EQUIPMENT CONSTITUTION

The typical PS BDA unit consists of the following components:

**Power Amplifier (PA):** It provides power amplification for both the UL and DL branches.

**Main Control Unit (MCU):** The MCU is used to monitor and control the operation of the repeater. It also provides the communication interface for remote control and status indication. LED indicators provide the operation status of the MCU.

**Duplexer:** The DPX is located near the MT and DT terminals and permits the uplink and downlink signals to share a common antenna.

**Digital Integrated Module and Power Amplifier:** Consists of the Power Conversion module, RF module, digital process module and monitoring modules. The Power Conversion module converts +28V DC voltage into +9VJK and +9VRF. +9VJK, +9VRF are supplied to the monitoring unit, and the RF unit in the integrated module separately. The RF module amplifies and converts the RF signal to IF signal. The Digital process module converts the IF signal into baseband signal via AD conversion and extraction, and filtering. After that, the IF signal will be amplified and converted to an RF signal by the RF module for RF filtering and amplification. The Monitoring module monitors and controls the system parameters and is the interface for both remote monitoring and local commissioning.

**Power Supply Unit (PSU):** The PSU converts the input voltage into a stable DC supply to provide power for the internal functional modules.

## 3 INSTALLATION

### 3.1 WARNINGS AND ALERTS

#### Radio Frequency Energies

There may be situations, particularly for workplace environments near high-powered RF sources, where recommended limits for safe exposure of human beings to RF energy could be exceeded. In such cases, restrictive measures or actions may be necessary to ensure the safe use of RF energy.

#### High Voltage

The equipment has been designed and constructed to prevent, as far as reasonably practicable danger. Any work activity on or near equipment involving installation, operation or maintenance must be, as far as reasonable, free from danger.

Where there is a risk of damage to electrical systems involving adverse weather, extreme temperatures, wet, corrosive or dirty conditions, flammable or explosive atmospheres, the system must be suitably installed to prevent danger.

#### Protective Earthing

Equipment provided for the purpose of protecting individuals from electrical risk must be suitable for the purpose and properly maintained and used.

#### Handling Precautions

This covers a range of activities including lifting, lowering, pushing, pulling, carrying, moving, holding or restraining an object, animal or person from the equipment. It also covers activities that require the use of force or effort, such as pulling a lever, or operating power tools.

Where some of the abovementioned activities are required, the equipment must be handled with care to avoid being damaged.

#### Electrostatic Discharge (ESD)

Observe standard precautions for handling ESD-sensitive devices. Assume that all solid-state electronic devices are ESD-sensitive. Ensure the use of a grounded wrist strap or equivalent while working with ESD-sensitive devices. Transport, store, and handle ESD-sensitive devices in static-safe environments.

## 3.2 SITE PLANNING CONSIDERATIONS

### 3.2.1 SITE PLANNING

#### Site Considerations

Outdoor equipment are designed to be waterproof, rainproof, and with snow protection. Temporary protection should be taken when the equipment enclosure is opened for installation or maintenance in an outdoor environment. The equipment must not be opened for installation or maintenance in bad weather (e.g. gale, storm rainfall, extreme temperatures and high humidity)

#### Installation Location

Mounting surface shall be capable of supporting the weight of the equipment.

In order to avoid electromagnetic interference, a proper mounting location must be selected to minimize interference from electromagnetic sources such as large electrical equipment.

#### Environmental

Humidity has an adverse effect on the reliability of the equipment. It is recommended to install the equipment in locations having stable temperature and unrestricted air-flow.

The installation location for the product should be well ventilated. The equipment has been designed to operate at the temperature range and humidity level as stated in the product specifications in the datasheet.

Direct sun light exposure to the equipment should be avoided. Provide additional shelter if necessary.

#### Power Supply

The power supply unit (PSU) provides power to all modules within the equipment. Depending on the product variant, it is recommended that the PSU be operated on a dedicated circuit breaker or fused circuit.

#### Grounding Requirement

Verify that the equipment has been well grounded. This includes antennas and all cables connected to the system. Ensure lightning protection for the antennas is properly grounded.

#### Cable Routing

Depending on equipment configuration, a variety of types of cables are required. Where applicable, ensure cables are properly routed and secured so that they are not damaged.

#### Manual Handling

During transportation and installation, take necessary handling precautions to avoid potential physical injury to the installation personnel and the equipment.

### 3.2.2 INSTALLATION CHECKLIST

- Working space available for installation and maintenance for each mounting arrangement. Ensure unrestricted airflow.
- Ensure earth ground point is within reach of the ground wire.
- Ensure a power source is within reach of the power cord and the power source has sufficient capacity.
- Where appropriate, ensure unused RF connectors are terminated.
- Do not locate the equipment near large transformers or motors that may cause electromagnetic interference.
- Reduce signal loss in feeder cable by minimizing the length and number of RF connections.
- Ensure VSWR of antennas system < 1.5:1.
- Ensure equipment will be operated within the stated environment (see datasheet)
- Observe handling of all cables to prevent damage.
- Donor antenna should have a narrow beamwidth and positioned in line-of-sight (LOS) to the donor BTS site so that the donor signal level is maximized. This allows the use of minimum gain to achieve the maximum DL output power. The UL gain is typically set lower than or equal to the DL gain to minimize noise interference to the donor BTS
- Service antennas should be selected based on the type of service area, e.g., indoor antenna for indoor application, and panel antenna for outdoor application.



### 3.3 INSTALLATION PROCEDURES

#### 3.3.1 GOODS INWARDS INSPECTION

- Verify the number of packages received against the packing list.
- Check all packages for external damage; report any external damage to the shipping courier. If there is damage, a shipping agent should be present before unpacking and inspecting the contents because damage during transit is the responsibility of the agent.
- Open and check each package against the packing list. If any items are missing, contact Comba.
- Do not remove items from anti-static packing until ready for installation. If damage is discovered at the time of installation, contact the shipping agent.

#### 3.3.2 TOOLS

See Appendix A for a full list of the recommended tools required for installation and routine maintenance.

#### 3.3.3 PREPARATION

- Wall mounting with the masonry bolts supplied, which make use of the outer holes.

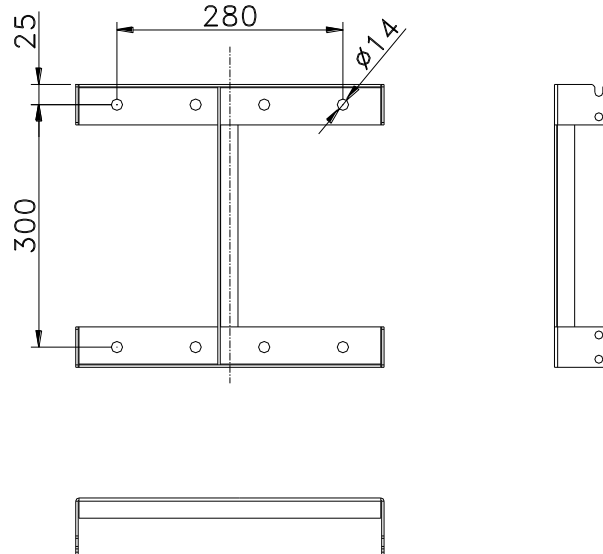

Figure 4: Mounting Rack Overview

### 3.3.4 WALL MOUNTING

- Drill four holes on the wall using the position of four holes on the mounting rack as a guide. Fix the mounting rack to the wall using four masonry bolts (M10x110mm).
- Install the Mounting Rack to the wall.
- Hang the equipment and secure the enclosure to the mounting rack.

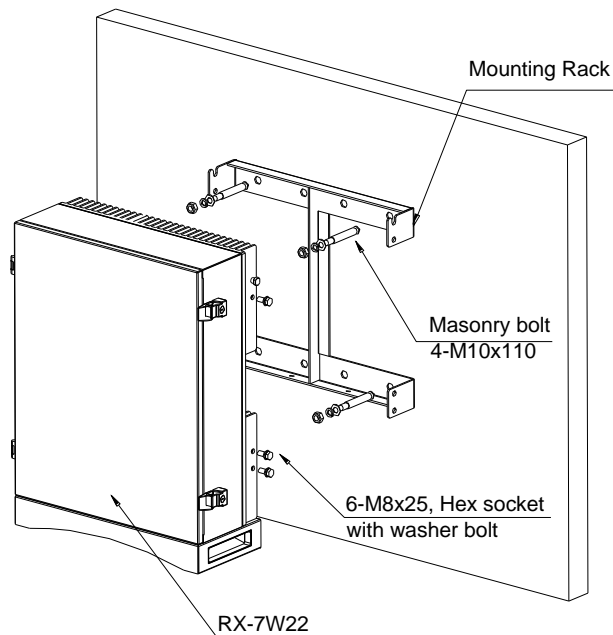

Figure 5: PS BDA Wall Mounting

### 3.3.5 DRIP-LOOP

Comba recommends that every horizontal cable entry to the equipment forms a 'U' before its entry to the equipment. Water on the cable will drip down at the bottom of the loop and will not accumulate at the equipment connectors.

### 3.4 EQUIPMENT CONNECTORS

#### 3.4.1 PS BDA CONNECTORS

The PS BDA is designed for all cable entries from the right or left of the enclosure, as shown in the following figure.

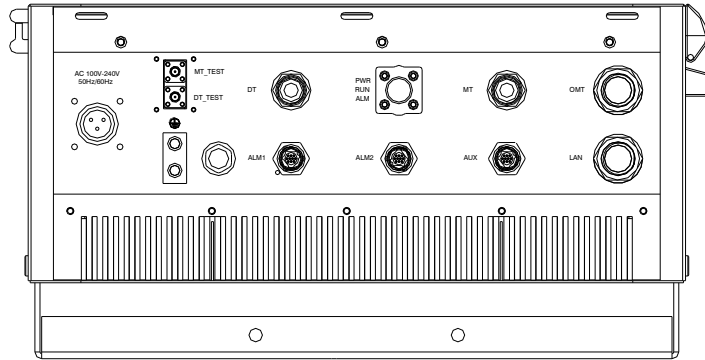

Figure 6: Equipment Connectors

Table 1: Equipment Connectors

Identifier	Descriptions
Power <sup>1</sup>	Power cable connector for a pre-installed power cord for connection to AC (e.g. AC 100-240V 50Hz/60Hz).
DT Test	SMA connector for DT port test, -22dB coupling to DT port, available for both downlink and uplink test.
MT Test	SMA connector for MT port test, -22dB coupling to MT port, available for both downlink and uplink test.
DT	N-Female connector for connection to donor antenna.
MT	N-Female connector for connection to service antenna.
OMT	RJ45 Connector for local WEB GUI connection.
ALM1	Connector for connection to dry contact alarm 1 and 2.
ALM2	Connector for connection to dry contact alarm 3 and 4.
AUX	Reserved.
LAN	RJ45 Connector for internet connection (Ethernet type only).

<sup>1</sup> The voltage identification is a variant due to electricity system diversity of global regions. The power cable connector might be identified for AC 110V, AC 220V, AC 110V/220V, or DC -48V respectively. Please refer to specific product or contact local sales if any doubt.

### 3.4.2 PS BDA LED Indicators

The LED indicators help user to check the equipment status easily.

Table 2: LED Indicators

Identifier	Colour	Indication
PWR	Green	Power indicator. ON = power on; OFF = power off.
RUN	Green	Operation indicator, flashes every second to indicate normal operation.
ALM	Red	Alarm indicator. ON = alarm; OFF = no alarm.

### 3.4.3 GROUNDING CONNECTION

#### Ground Connection

To ensure safe operation of the product, a ground (earth) connection is required. For single phase AC power source, the product must be grounded by connecting the “earth wire” of the power cord to the ground terminal of the AC supply. For operating this product with DC power system (such as rectifiers), the product should not be connected to power systems that switch open the return lead because the return lead could function as the ground (earth) connection for the equipment.

#### Protective Ground Connection

The enclosure must be grounded securely by connecting a copper wire (CSA 16mm<sup>2</sup>) to the grounding terminal on the equipment/rack, and the other end to a protective ground (i.e. building earth point). An internationally acceptable color code of the ground connection wire is green/yellow.

Such a ground connection implements the “Protective Ground Connection”, and must be connected to the equipment at the designated ground point. In general, do not connect the supply before establishing an adequate ground (earth) connection.

Construct the ground wire, and use appropriate crimp connectors where necessary. Locate and connect the equipment grounding terminal to a protective ground (i.e. building earth point).

### 3.4.4 RF CABLE CONNECTION

Single band PS BDA RF cables connection is as follows:

- PS BDA MT port → Connects to the feeder cable from service antennas.
- PS BDA DT port → Connects to the feeder cable from donor antennas.

### 3.4.5 ETHERNET CONNECTION

Connect Ethernet with ‘LAN’ port in the panel, Ethernet type only.

### 3.4.6 DRY CONTACT CABLE CONNECTION

Below please find the pin definitions of dry contact cables.

Table 3: Pin Definition of Dry Contact Cable

Pin NO.	Pin	Input	Output
<b>ALM1</b>			
1	CLOSE1	1(A)	Red
2	COM1	2(B)	White
3	OPEN1	3(C)	Blue
4	CLOSE2	4(D)	Black
5	COM2	5(E)	Brown
6	OPEN2	6(F)	Purple
7	RR_A	7(G)	Green
8	RR_B	8(H)	Orange
9	NC	9(J)	Yellow
10	GND	10(K)	Grey
<b>ALM2</b>			
11	CLOSE3	1(A)	Red
12	COM3	2(B)	White
13	OPEN3	3(C)	Blue
14	CLOSE4	4(D)	Black
15	COM4	5(E)	Brown
16	OPEN4	6(F)	Purple
17	GND	7(G)	Green
18	NC	8(H)	Orange
19	NC	9(J)	Yellow
20	NC	10(K)	Grey
<b>AUX</b>			
21	EXT ALM0	1(A)	Red
22	EXT ALM1	2(B)	White
23	EXT ALM2	3(C)	Blue
24	EXT ALM3	4(D)	Black
25	EXT Li+	5(E)	Brown
26	EXT Li+	6(F)	Purple
27	NC	7(G)	Green
28	GND	8(H)	Orange
29	EXT Li-	9(J)	Yellow
30	EXT Li-	10(K)	Grey

End of Section

## 4 COMMISSIONING

### 4.1 PRE-COMMISSIONING TASKS

After equipment installation, perform the following steps before equipment powering and commissioning:

- Verify that the expected voltage, current and power levels do not violate any ratings.
- Visually inspect the power connection within the equipment. Ensure that the power cable is correctly and securely connected, including the grounding wire, RF cable and other cables.
- Check the grounding connection and verify that the ground resistance is less than  $5\Omega$ .
- Test the antenna system and ensure that the echo loss within working frequency is less than  $-14\text{dB}$  ( $\text{VSWR} < 1.5$ ).

## 4.2 COMMISSIONING PROCEDURE

Perform the following procedures for system commissioning.

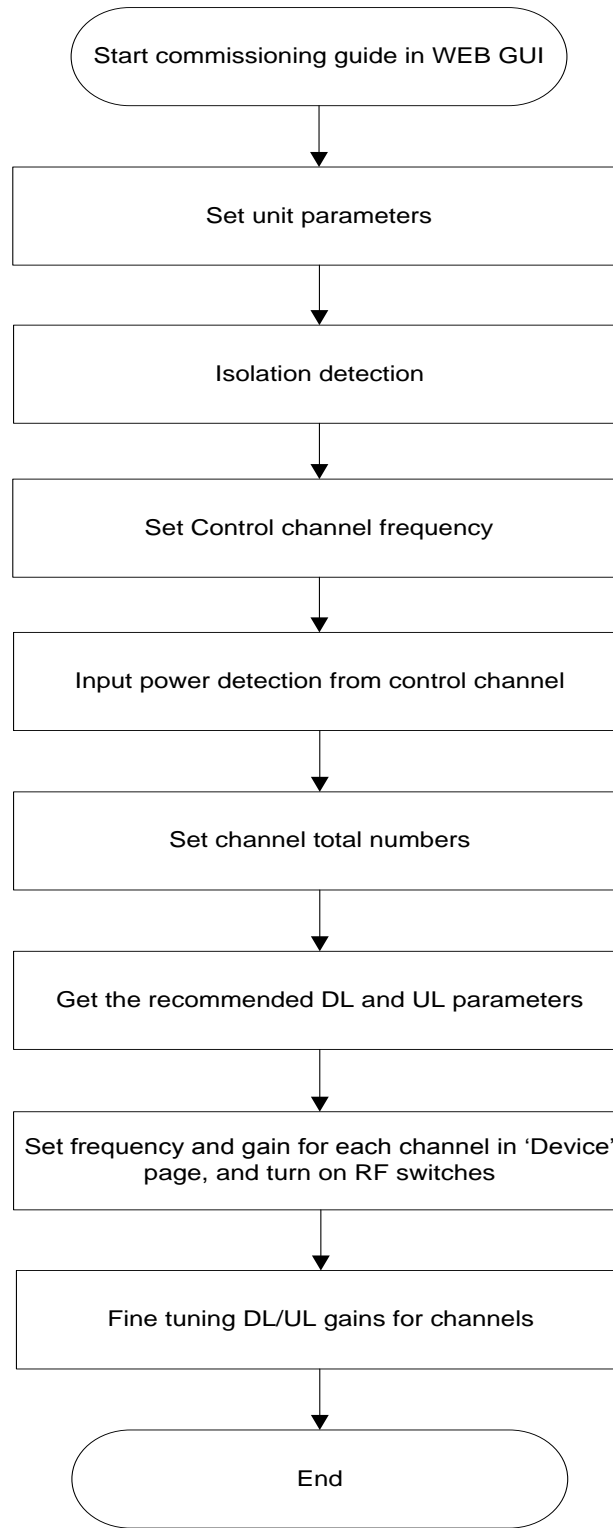

Figure 7: Commissioning Procedure

Table 4: Commissioning Task Explanation

Commissioning Tasks	Observation
1. Isolation detection	<ul style="list-style-type: none"> <li>● Detect isolation of service antenna and donor antenna.</li> </ul>
2. Set control channel frequencies	<ul style="list-style-type: none"> <li>● Enter the center frequency of the main control channel, the commissioning guide will provide recommended DL/UL gain settings based on main control channel input power and the total channel numbers.</li> <li>● Users can skip this step and directly finish the commissioning guide even if the frequency information or the total channel numbers are unknown. Users are able to set the DL/UL gain manually any time after the isolation detection has been completed and passed.</li> </ul>
3. Set Channel No.	<ul style="list-style-type: none"> <li>● Enter the total channel numbers</li> </ul>
4. Recommended DL and UL gain parameters	<ul style="list-style-type: none"> <li>● The commissioning guide will provide recommended DL/UL gain settings.</li> <li>● Users will still need to set all the gains manually in the “Device” pages, and the frequencies for all the independent channels in the same “Device” pages after the commissioning process is finished.</li> </ul>

End of Section



## 5 WEB GUI

The PS BDA can be monitored and controlled via the WEB GUI; use the following guide to finish system parameter setting and commissioning.

### 5.1 WEB GUI CONNECTION

**Step 1:** Connect the OMT port to the PC RJ45 port with the supplied RJ45 cable to set up a physical connection.

**Step 2:** Open a browser (browser IE7.0, IE8.0, Chrome or Firefox, suggested display resolution is 1024x768), input Web GUI **IP address: 192.168.8.101**, click [Enter].

NOTE: DHCP and DNS are also available to login to the Web GUI. The domain name is: [www.combaomt.com](http://www.combaomt.com).

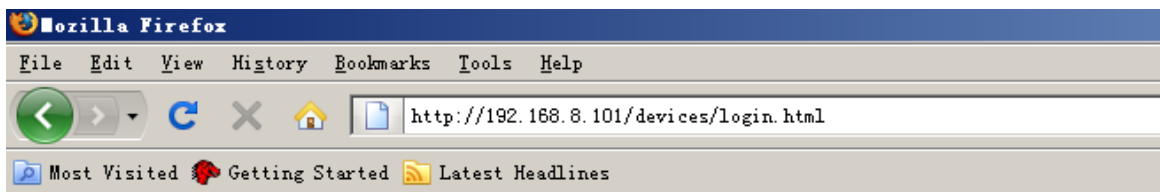

Figure 8: Input IP Address

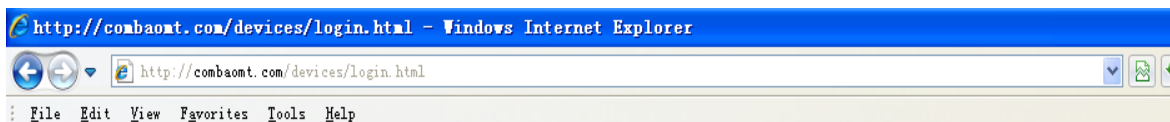

Figure 9: Input Domain Name

**Step 3:** Input **User Name: admin**; **Password** (default password: **admin**). Click [Log in].



Figure 10: Input User Name and Password

## 5.2 WEB GUI INTRODUCTION

After log in, the Web GUI main screen will appear.

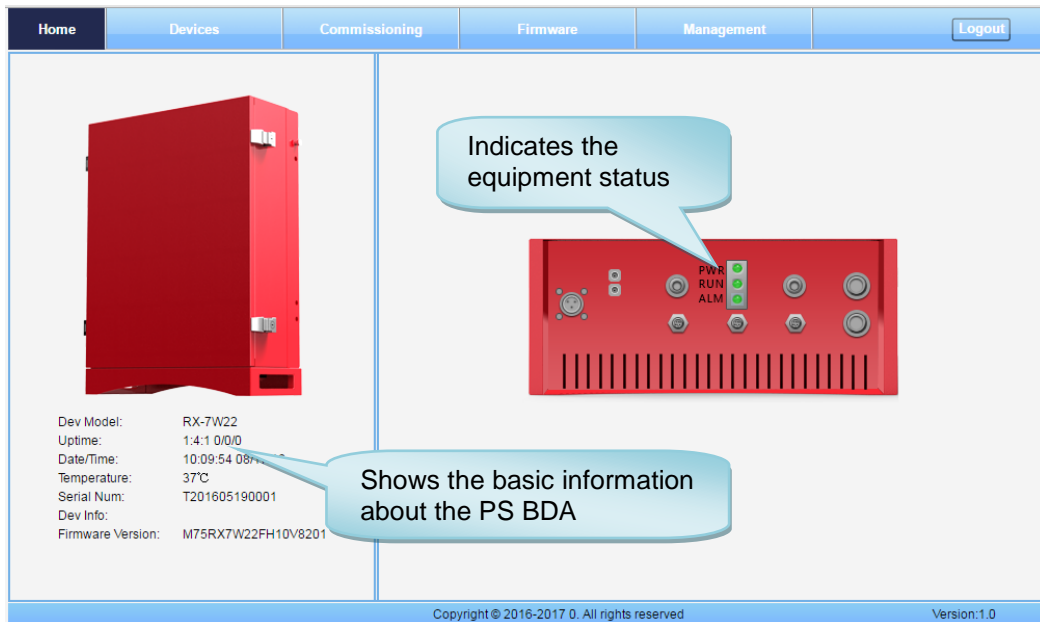

Figure 11: Web GUI Main Screen

On Comba Web GUI Home Screen, there are four Menu bars: **[Devices]**, **[Commissioning]**, **[Firmware]** and **[Management]**.

### 5.2.1 [DEVICES]

The [Devices] Screen shows the equipment status, such as PA status, alarm information, etc.

Overview Screen

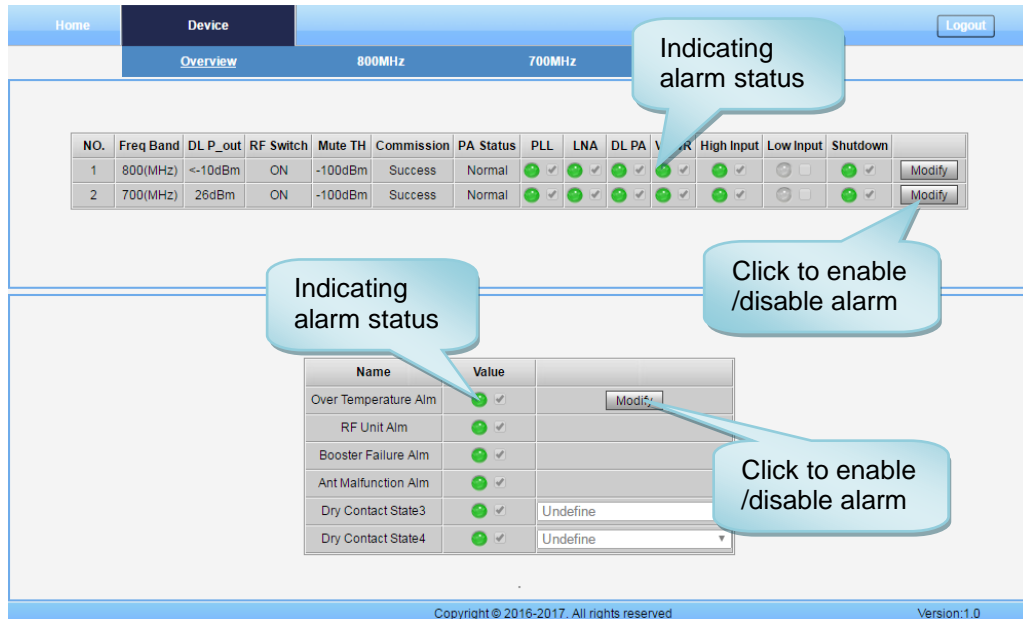

Figure 12: Overview Screen

800MHz Screen

This screen is only available for the dual band PS BDA or 800MHz PS BDA.

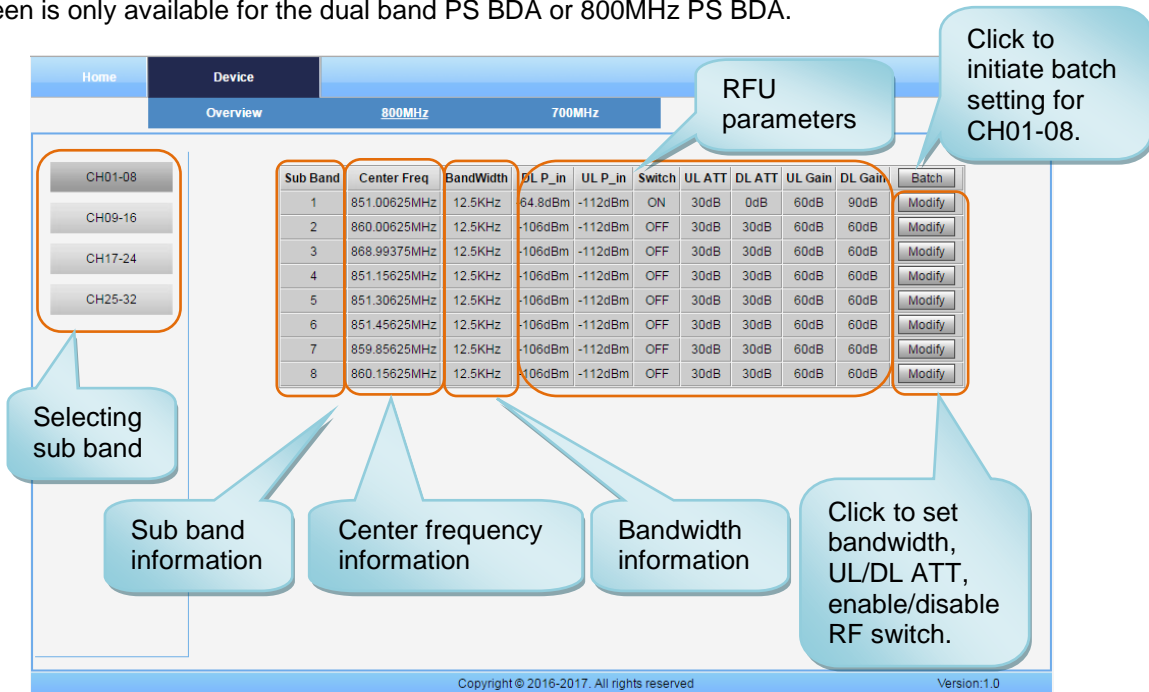

Figure 13: 800MHz Screen

700MHz Screen

This screen is only available for the dual band PS BDA or 700MHz PS BDA.

The screenshot shows a web interface for configuring 700MHz channels. On the left, there are buttons for selecting sub-bands: CH01-08, CH09-16, CH17-24, and CH25-32. A callout 'Selecting sub band' points to these buttons. The main area contains a table of RFU parameters for 8 sub-bands. Callouts identify the table as 'RFU parameters' and point to specific columns: 'Sub band information', 'Center frequency information', and 'Bandwidth information'. A 'Batch' column with 'Modify' buttons is also highlighted with a callout: 'Click to set bandwidth, UL/DL ATT, enable/disable RF switch.' Another callout points to the 'Batch' column: 'Click to initiate batch setting for CH01-08.'

Sub Band	Center Freq	BandWidth	DL P_in	UL P_in	Switch	UL ATT	DL ATT	UL Gain	DL Gain	Batch
1	774.99375MHz	12.5KHz	-63.7dBm	-113dBm	ON	30dB	0dB	60dB	90dB	Modify
2	772.00625MHz	12.5KHz	-107dBm	-113dBm	OFF	30dB	30dB	60dB	60dB	Modify
3	769.00625MHz	12.5KHz	-107dBm	-113dBm	OFF	30dB	30dB	60dB	60dB	Modify
4	769.15625MHz	12.5KHz	-107dBm	-113dBm	OFF	30dB	30dB	60dB	60dB	Modify
5	769.30625MHz	12.5KHz	-107dBm	-113dBm	OFF	30dB	30dB	60dB	60dB	Modify
6	769.45625MHz	12.5KHz	-107dBm	-113dBm	OFF	30dB	30dB	60dB	60dB	Modify
7	771.85625MHz	12.5KHz	-107dBm	-113dBm	OFF	30dB	30dB	60dB	60dB	Modify
8	772.15625MHz	12.5KHz	-107dBm	-113dBm	OFF	30dB	30dB	60dB	60dB	Modify

Figure 14: 700MHz Screen

5.2.2 [COMMISSIONING]

A work flow of the commissioning process is shown on [Commissioning] Screen. Click the [Start] button, the software will guide you through the commissioning step by step. For details, please refer to chapter 5.3.

The screenshot shows the 'Commissioning' screen with a navigation bar (Home, Devices, Commissioning, Firmware, Management, Logout) and a 'Work Flow' diagram. The workflow consists of five steps: Start, Site Info Setting, Isolation Detection, RF Setting, and Finish. A 'Start' button is located at the bottom of the screen. A 'Tips' section contains the text: 'Please click the "Start" button to begin the process.'

Figure 15: [Commissioning] Screen

5.2.3 [FIRMWARE]

There are two functions on the [Firmware] bar: [upgrade] and [swap]. [Upgrade] is used to upgrade software, and [Swap] is to replace the current firmware version with the previous one.

Follow the steps shown below figure to upgrade the firmware.

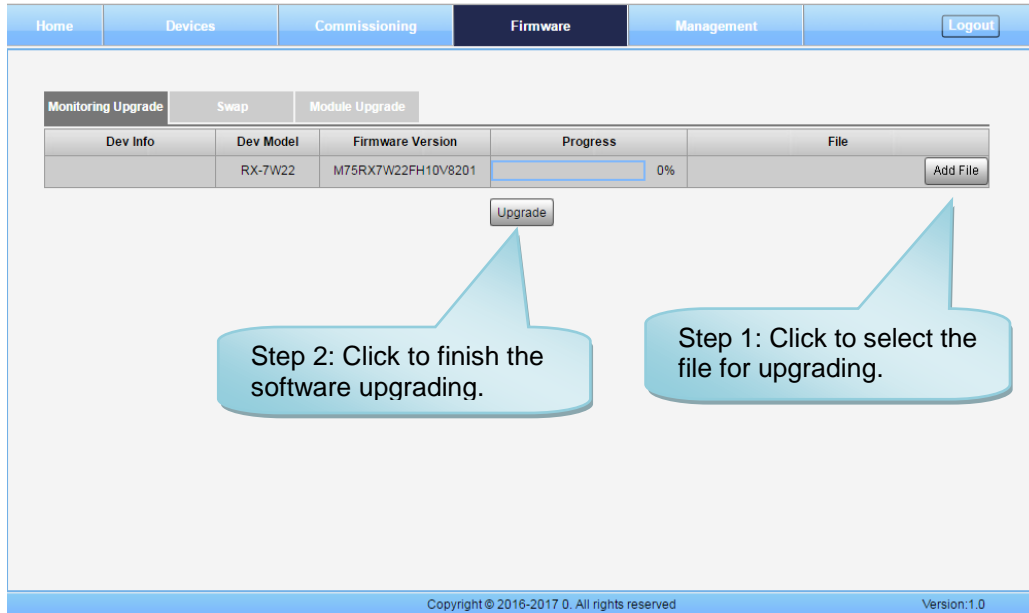

Figure 16: [Firmware] Screen – MCU Firmware Upgrade

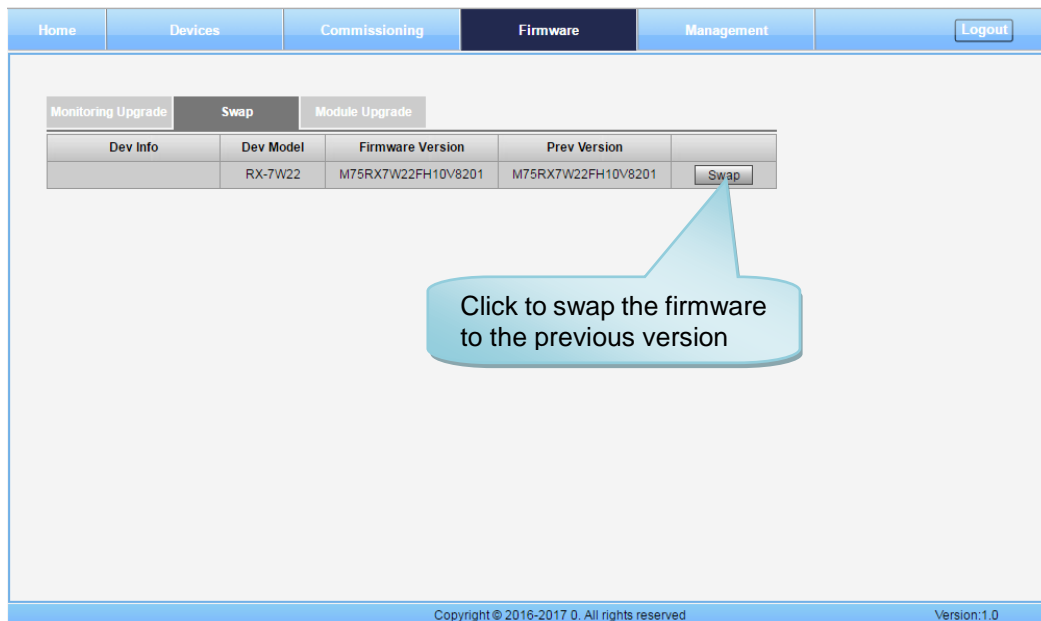

Figure 17: [Firmware] Screen – Firmware Swap

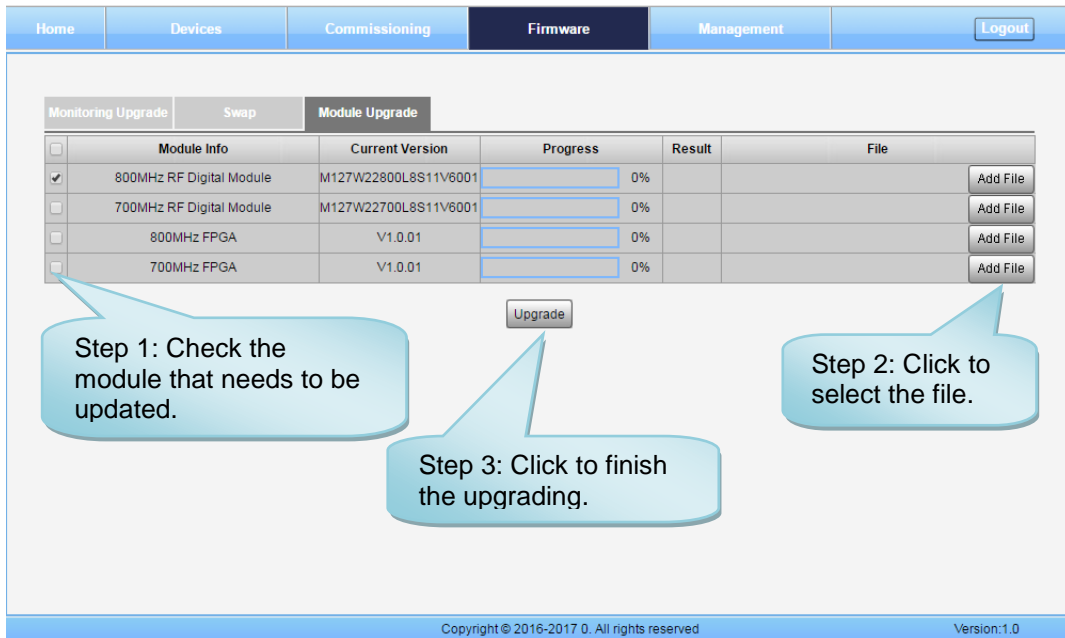

Figure 18: [Firmware] Screen – Module Update

### 5.2.4 [MANAGEMENT]

Other parameters can be configured on the [Management] Screen.

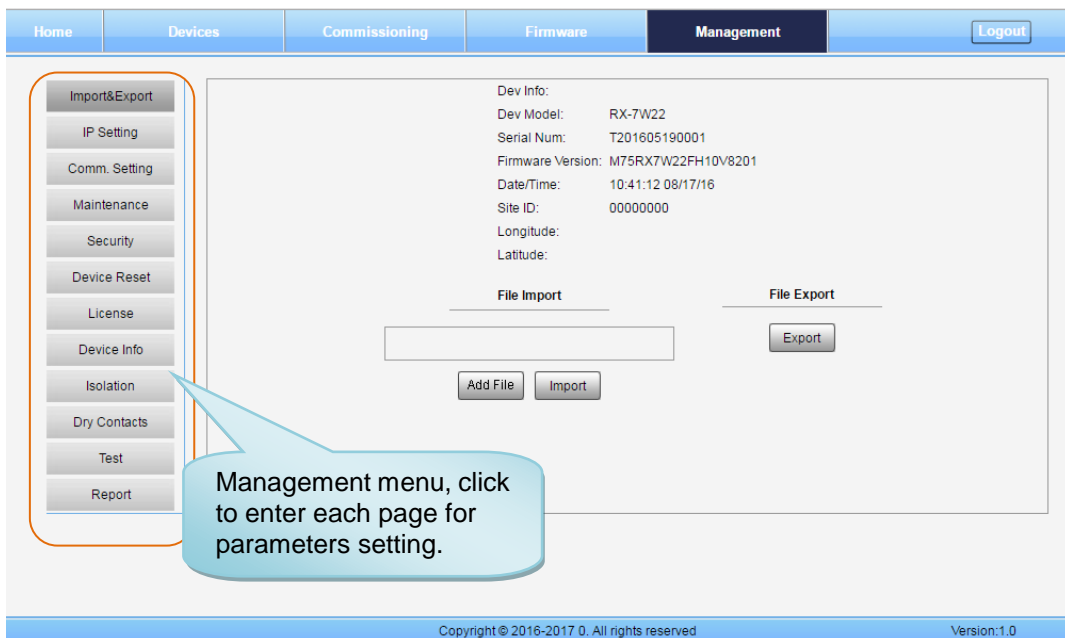

Figure 19: [Management] Screen

There are nine function bars list on the left side of the [Mangement] Screen.

➤ **Inport&Export**

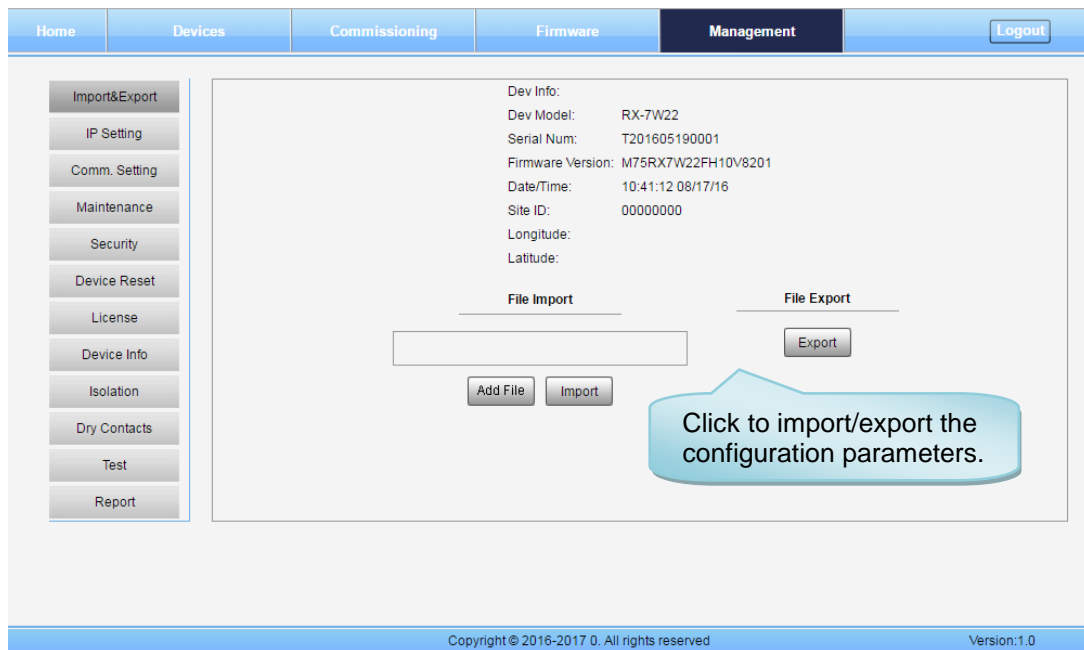

Figure 20: Management – Import & Export

The parameters that can be imported / exported include sub band, alarm enable, ATT value, RF switch, and DL output power.

This function can help users quickly configure PS BDA parameters. For example, if one PS BDA is finished configuration, users can export the parameters and save it as a file on the PC, and then import this file to other PS BDAs for faster set up of additional PS BDAs.

➤ IP Setting

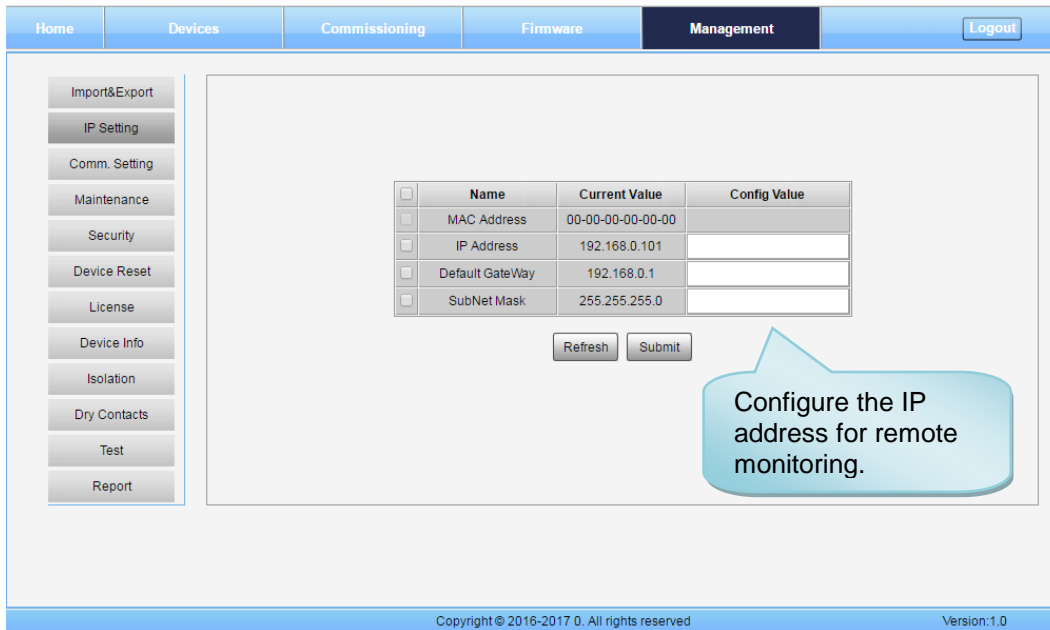

Figure 21: Management – IP Setting

Note: For remote monitoring, the IP Address must be set correctly based on the location IP of the remote connection. If more than one piece of equipment is connected to the public network through the same router, the router's local IP **CANNOT** be set as 192.168.8.\*.



➤ **Comm. Setting**

Home Devices Commissioning Firmware **Management** Logout

Import&Export  
IP Setting  
**Comm. Setting**  
Maintenance  
Security  
Device Reset  
License  
Device Info  
Isolation  
Dry Contacts  
Test  
Report

Communication Types:  SMS  PS  SNMP  ETHERNET

Snmp Version:  V2C  V3

<input type="checkbox"/>	Name	Current Value	Config Value
<input type="checkbox"/>	Read Community	public	
<input type="checkbox"/>	Write Community	private	
<input type="checkbox"/>	Trap Des: IP1	0.0.0.0	
<input type="checkbox"/>	Trap Des: IP2	0.0.0.0	
<input type="checkbox"/>	Trap Des: IP3	0.0.0.0	
<input type="checkbox"/>	Port Num	161	

Refresh Submit

Copyright © 2016-2017 0. All rights reserved Version:1.0

Figure 22: Management – Comm. Setting

Note: There are 4 available communication types: SMS, PS, SNMP and ETHERNET. You can choose a suitable type for remote monitoring.

➤ Maintenance

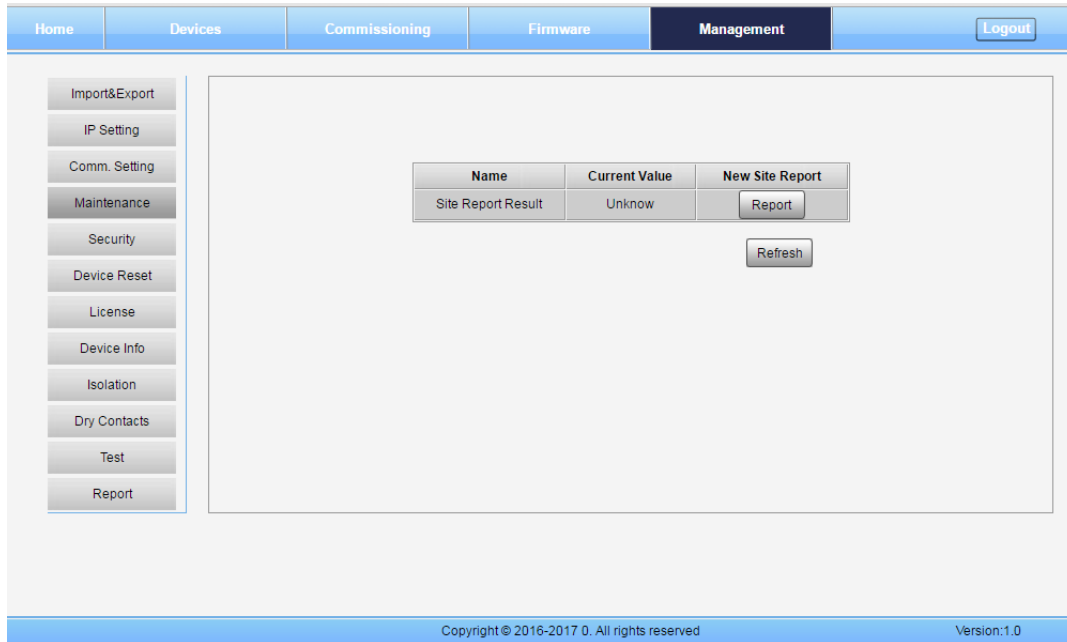

Figure 23: New Site Report is for easy monitoring set up

➤ Security

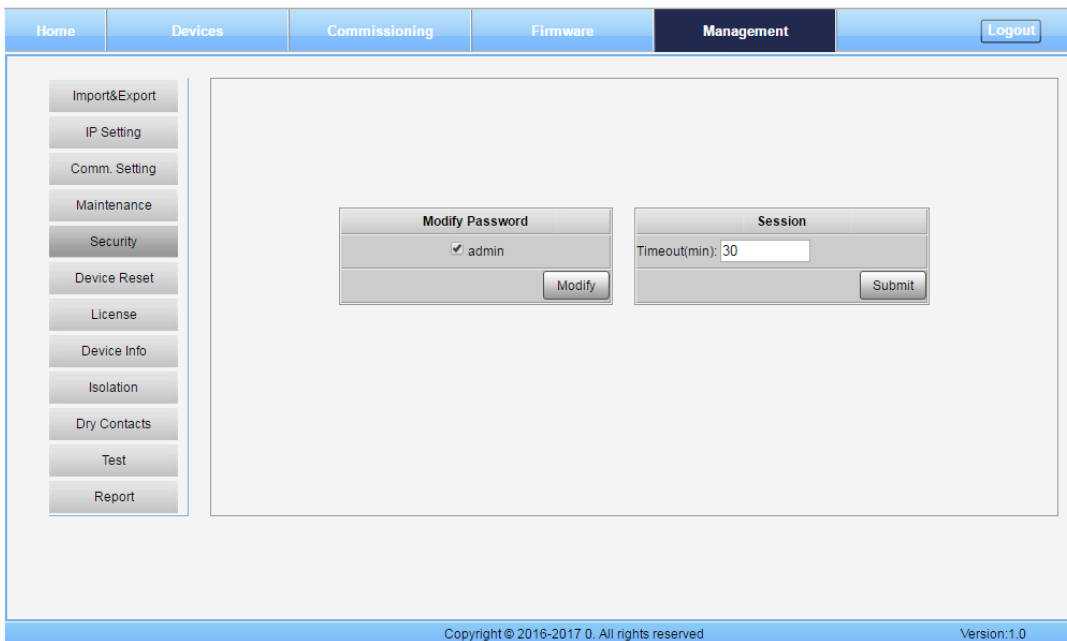

Figure 24: Management – Security

Click  , [Modify Password] window will pop-up.

Figure 25: Modify Password

Note: Username cannot be modified.

➤ **Device Reset**

Home	Devices	Commissioning	Firmware	<b>Management</b>	Logout
------	---------	---------------	----------	-------------------	--------

- Import&Export
- IP Setting
- Comm. Setting
- Maintenance
- Security
- Device Reset**
- License
- Device Info
- Isolation
- Dry Contacts
- Test
- Report

Dev Info:

Dev Model: RX-7W22

Serial Num: T201605190001

Firmware Version: M75RX7W22FH10V8201

Date/Time: 10:43:33 08/17/16

Site ID: 00000000

Longitude:

Latitude:

Device Reset

Clear History Alarms

Restore Default Setting

Freq Band	PA Reset
800(MHz)	<input type="button" value="Reset"/>
700(MHz)	<input type="button" value="Reset"/>

Copyright © 2016-2017 0. All rights reserved Version:1.0

Figure 26: Management – Device Reset

Note: Click  , all the parameters and alarms will be reset to factory default value. The Device Reset process will last about 2~4 minutes. For PMU monitor reset, users need to re-login to the WEB GUI.

➤ License

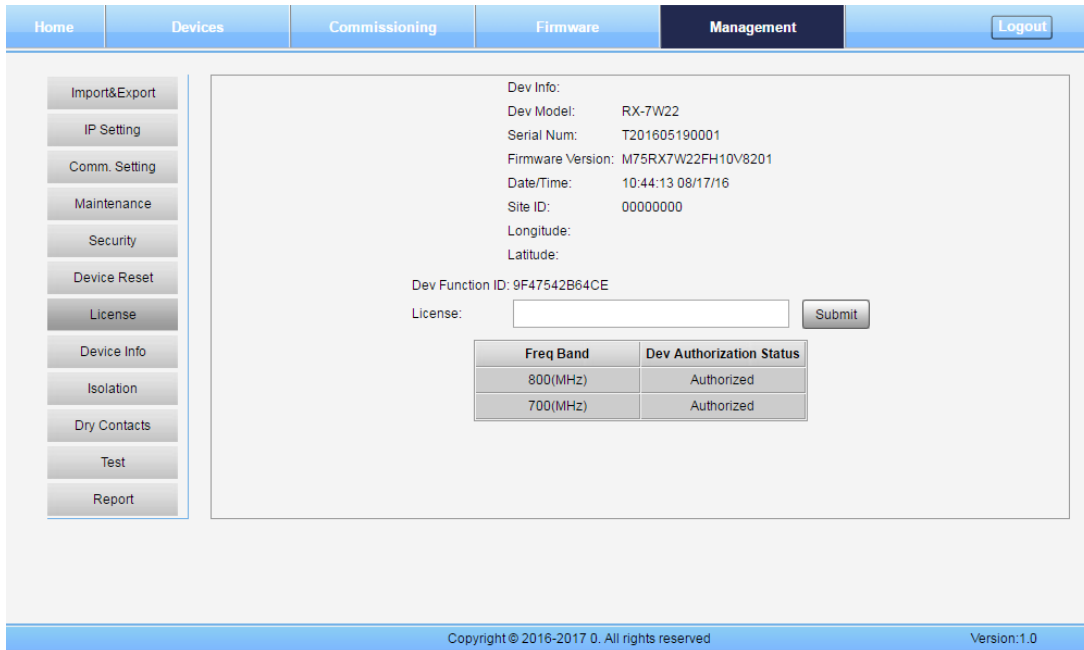

Figure 27: Management – License

For the CriticalPoint BDA, users are able to switch the configuration anytime by changing the license in the WEBOMT. There are 3 difference licenses: 700MHz single band license, 800MHz single band license and 700MHz/800MHz dual band license.

Both 700MHz and 800MHz single band licenses are provided with a single band unit. Users can switch between 700MHz configuration and 800MHz configuration. To upgrade from single band to dual band, users need to purchase the dual band upgrade license.

If the equipment is in dual band originally, no license will be provided, because the equipment already comes with dual band activated.

For more information please refer to appendix B for the license switch guide.

➤ **Device Info**

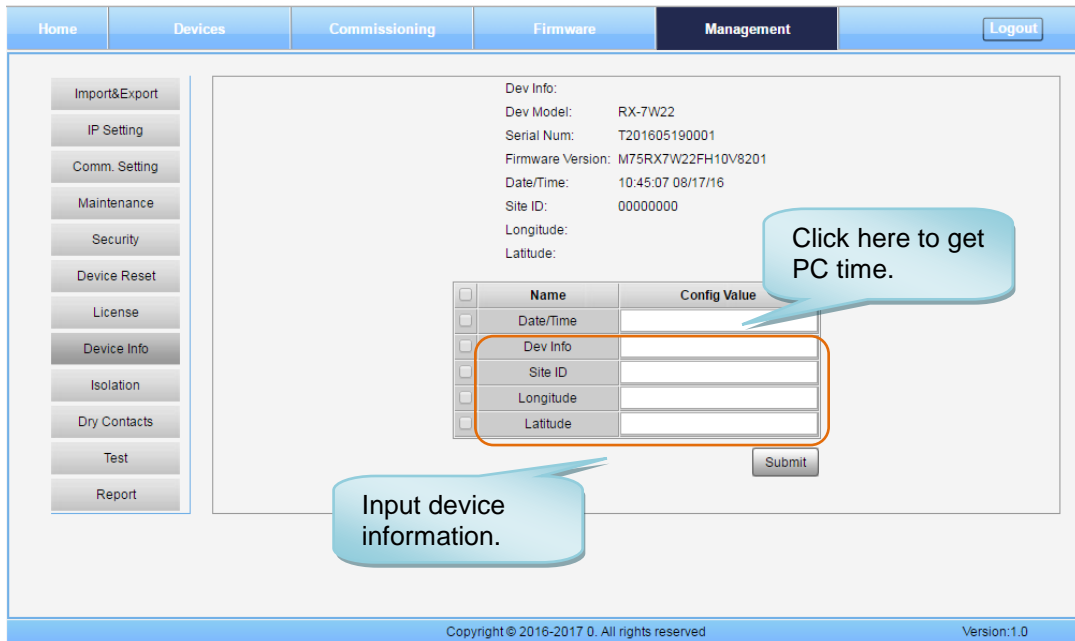

Figure 28: Management – Device Info

Note: Users can input a maximum of 30 characters in Device Info.

➤ **Isolation**

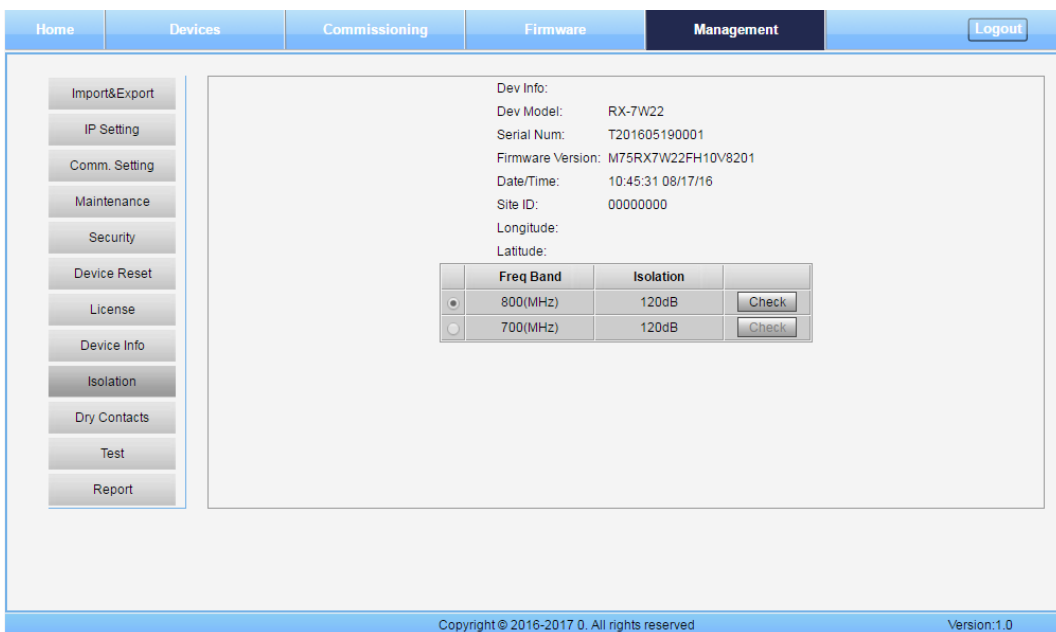

Figure 29: Management – Isolation

Note: This Step is the same as step 3 of [Commissioning]. Users can check isolation again by clicking the Check button.

➤ Dry Contact

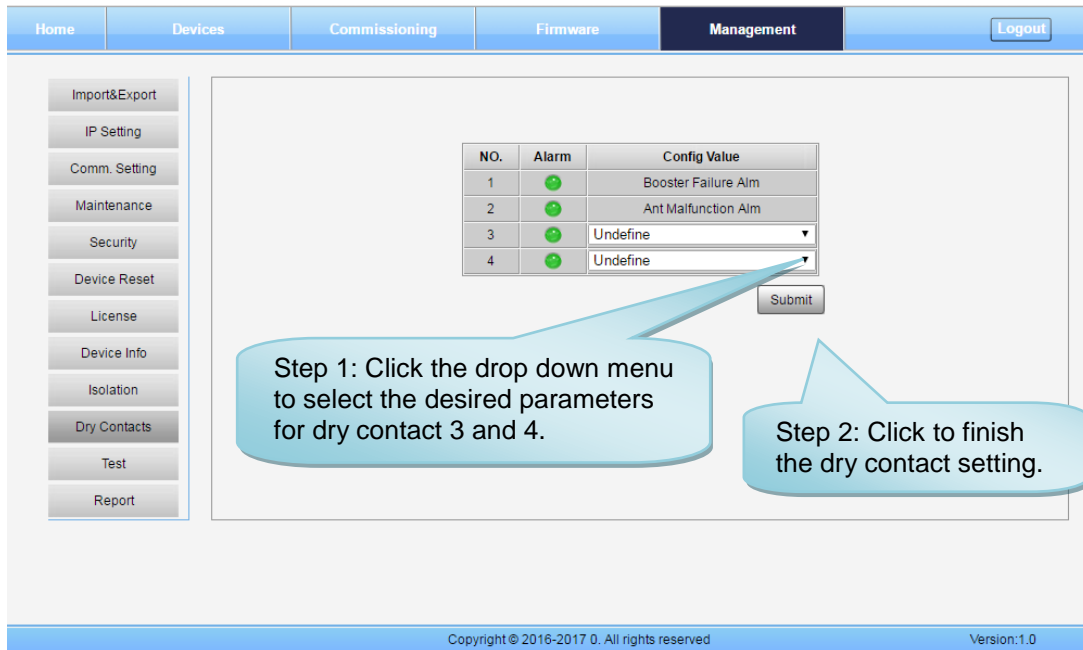

Figure 30: Management – Dry Contact

➤ Test

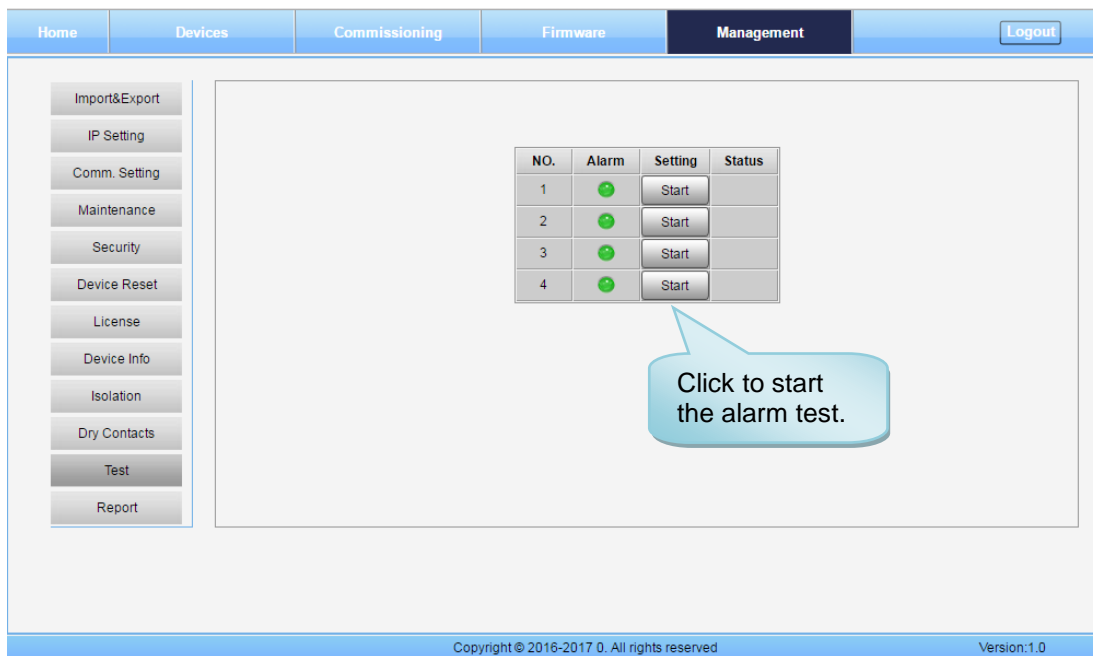

Figure 31: Management – Test

## ➤ Report

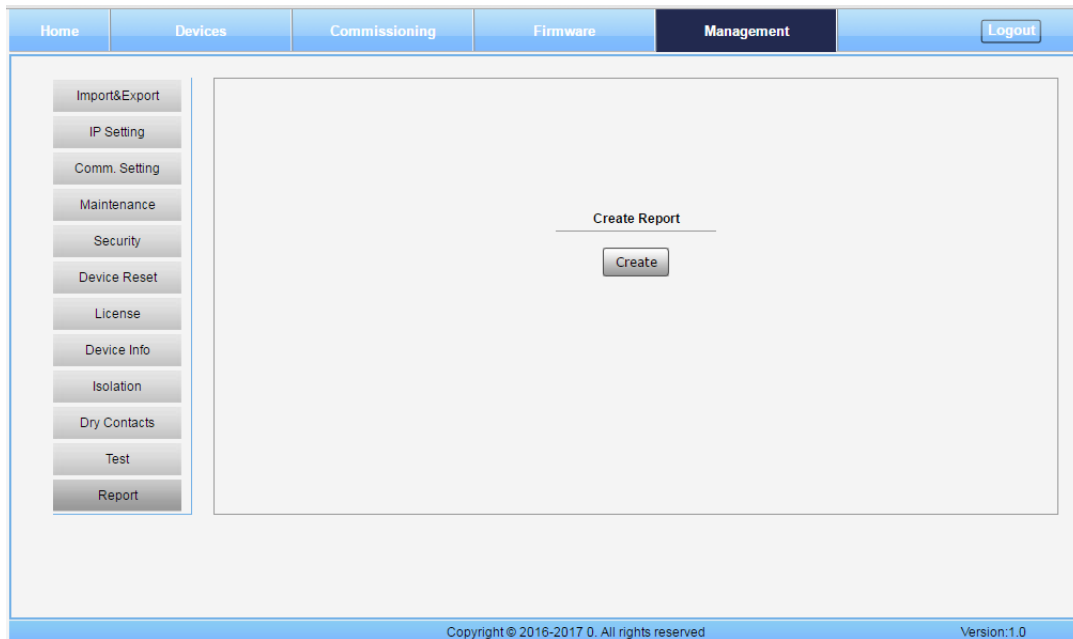

Figure 32: Management – Report

Note: Click Create to create the report (the report can't be created in IE browser) and make sure that PDF Reader software is installed on the computer. If not, the report will not be visible.

The device basic information, an overview of RF information and sub-band RF information are included in this report. Please refer to appendix D for an example of device report.

### 5.3 COMMISSIONING PROCEDURE

To complete the installation and commissioning, users need to follow the steps below.

**Step 1:** Click the Menu bar [Commissioning] on home screen, a work flow will be displayed.

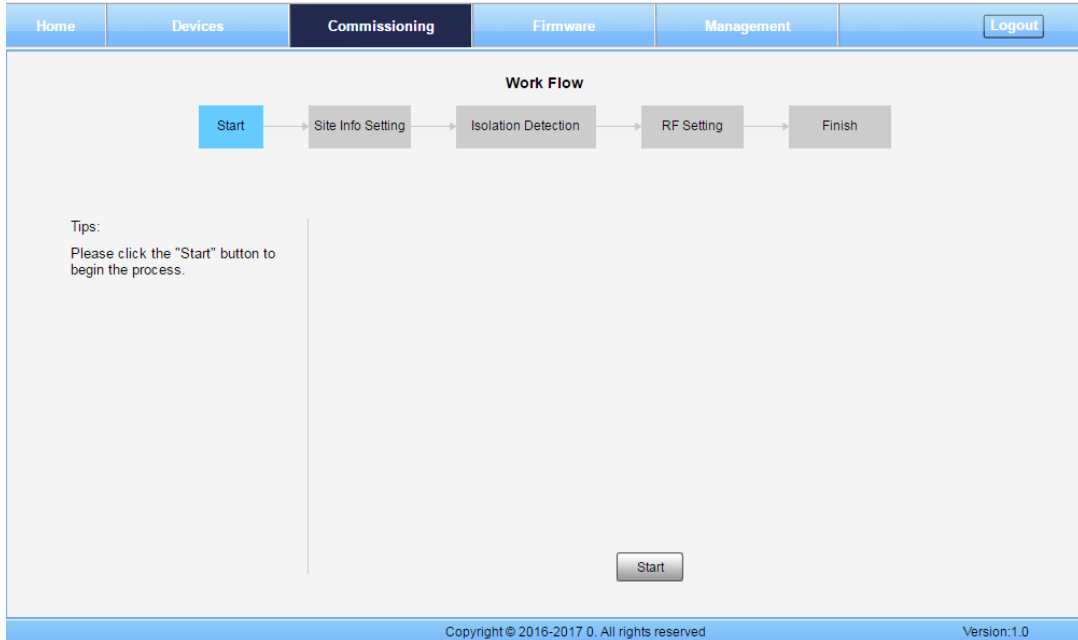

Figure 33: Commissioning Procedure – Start

**Step 2:** Click  to start the process.

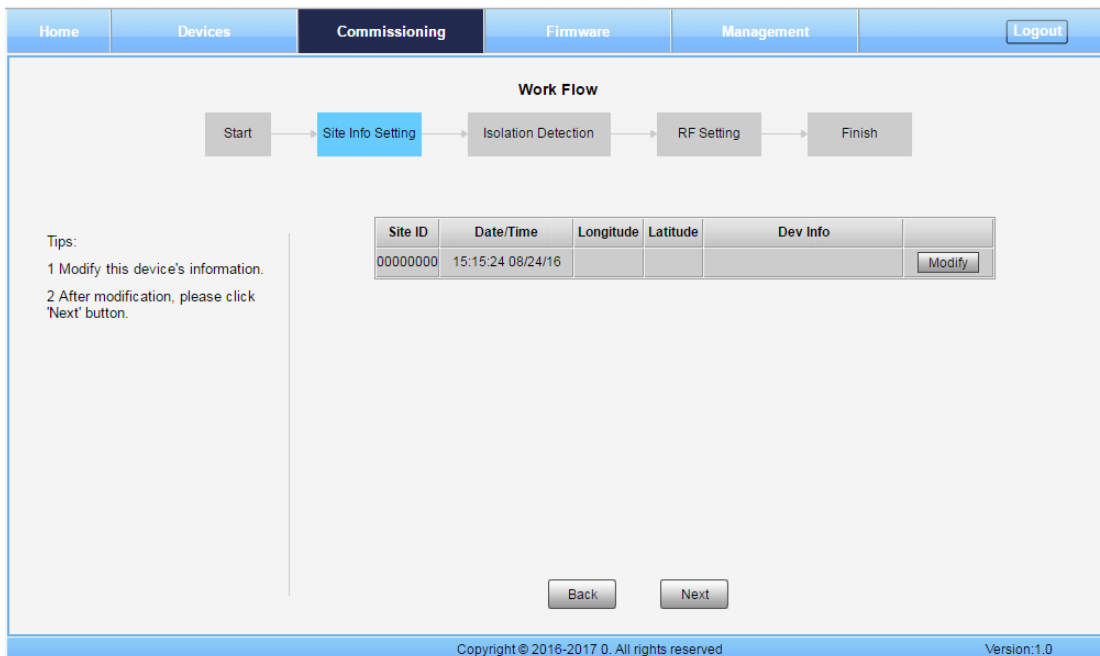

Figure 34: Commissioning Procedure – Site Info. Setting



Step 3: Click **Modify**, to set the site information.

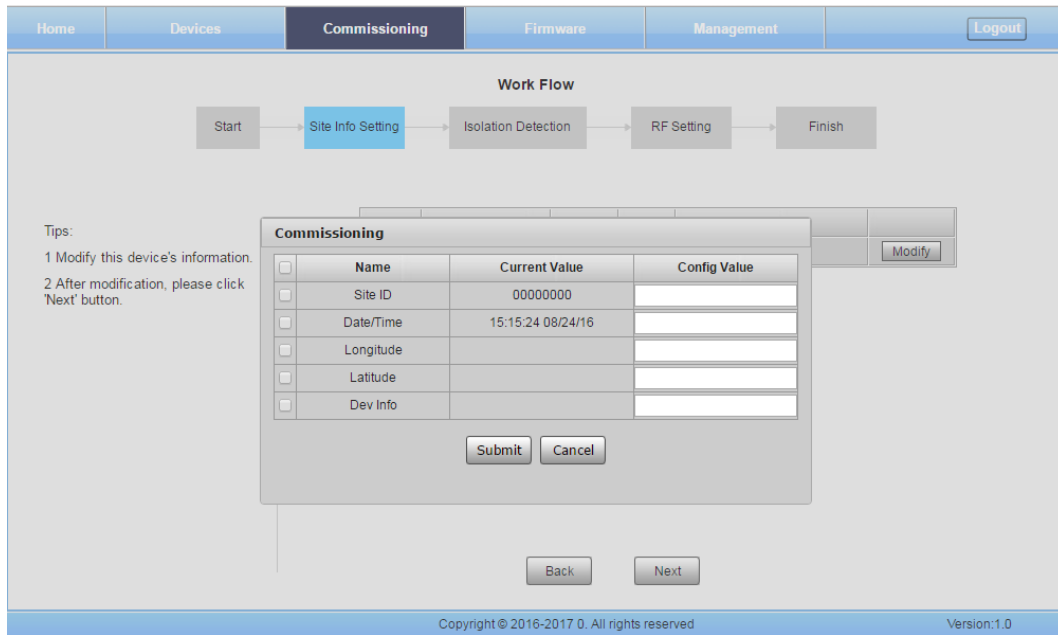

Figure 35: Device Information Setting

It is mainly used to record device location and Date/Time provides a time reference. Clicking the Config Value of Date/Time will update the Date/Time automatically.

**NOTE: Make sure the device is connected with appropriate donor and service antennas before proceeding to step 4.**

Step 4: Click **Next** to enter to Isolation Detection Screen.

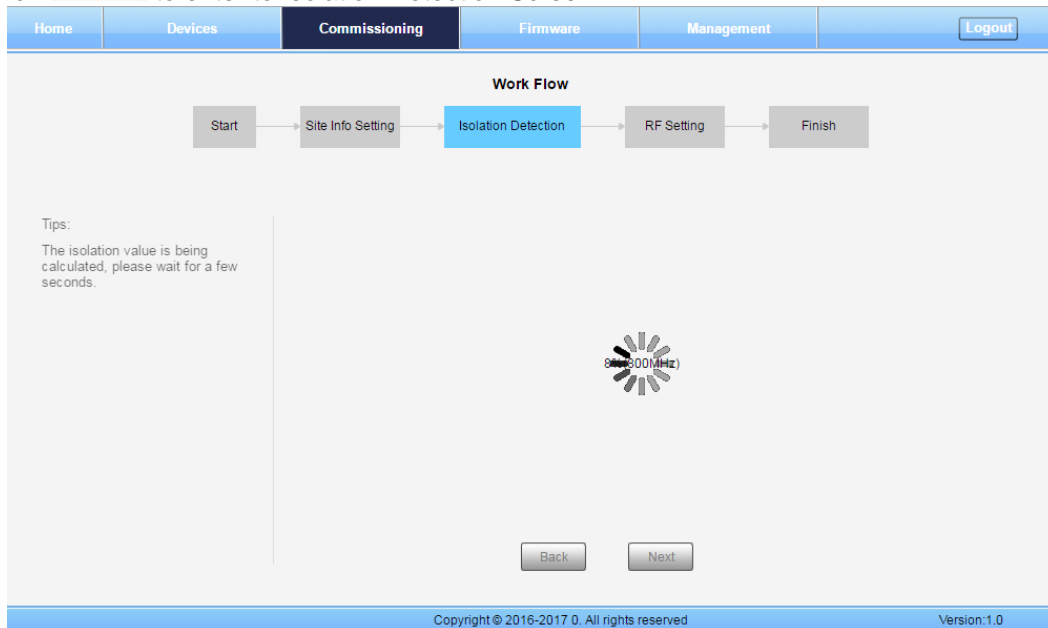



Figure 36: Commissioning Procedure – Isolation Detection

- Select a frequency band (RFU) that needs to be commissioned.
- Click  to start Isolation Detecting, then a [Confirm] window will pop-up.
- Click  to continue. If isolation detection passes, the process will go to the RF Setting Screen shown as Figure 38. If failed, a Tips window will pop-up, users need to check whether the system isolation is adequate.

**NOTE:** At the end of the first frequency band commissioning, users can start other frequency band commissioning.

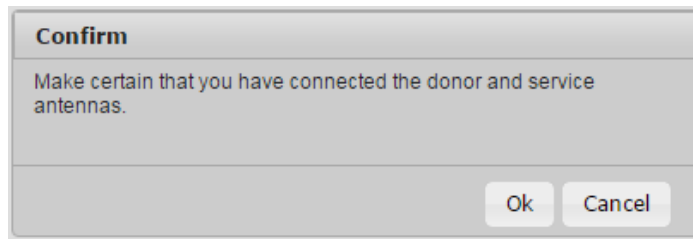

Figure 37: Commissioning Procedure – Isolation Detection Confirm

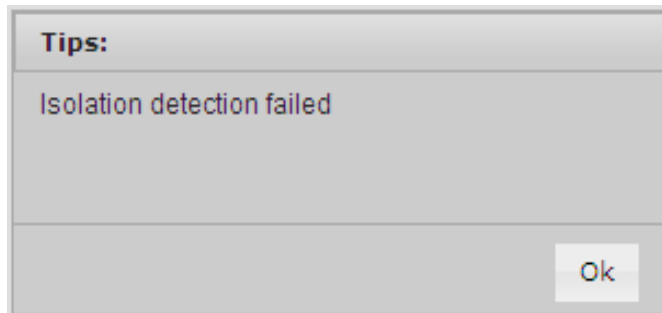

Figure 38: Commissioning Procedure – Isolation Detection Failed

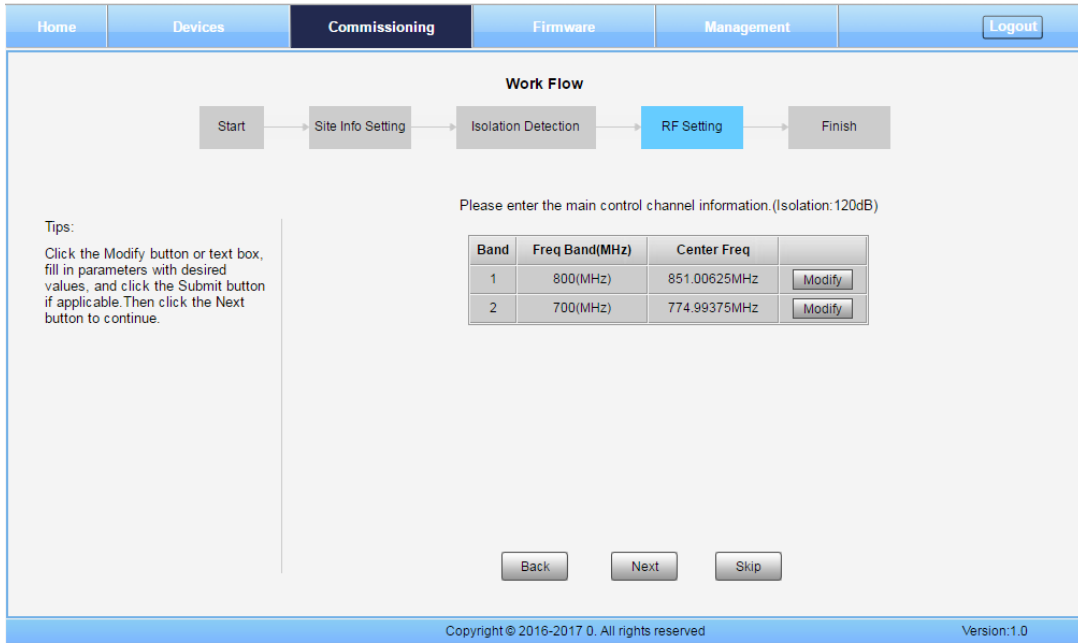

Figure 39: Commissioning Procedure – Isolation Detection Finish

**Step 5:** RF Setting Screen for setting the center frequency.

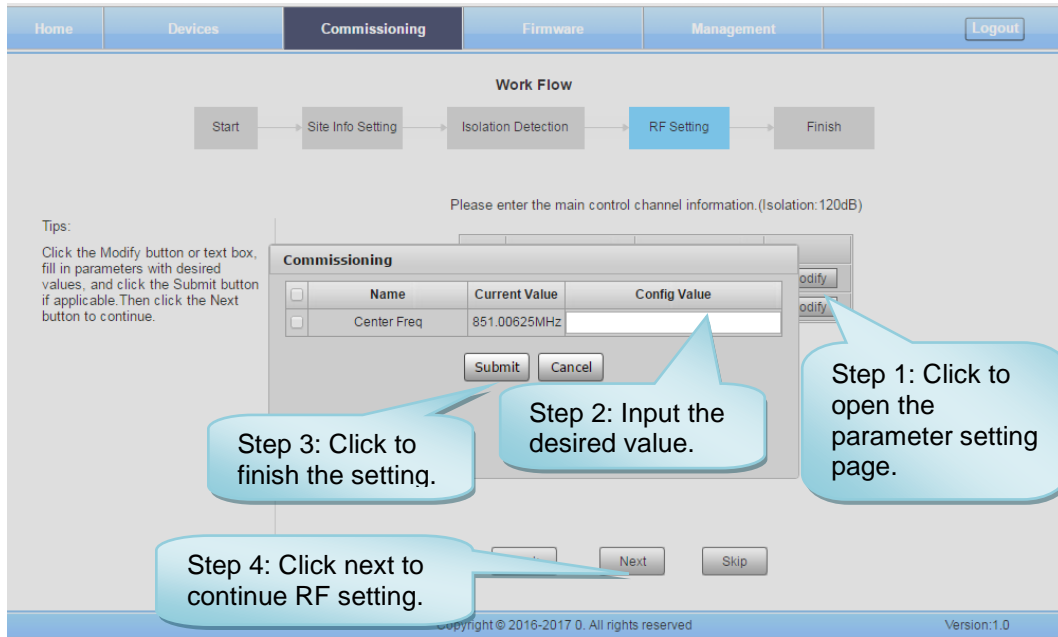

Figure 40: Commissioning Procedure – Center Frequency Setting

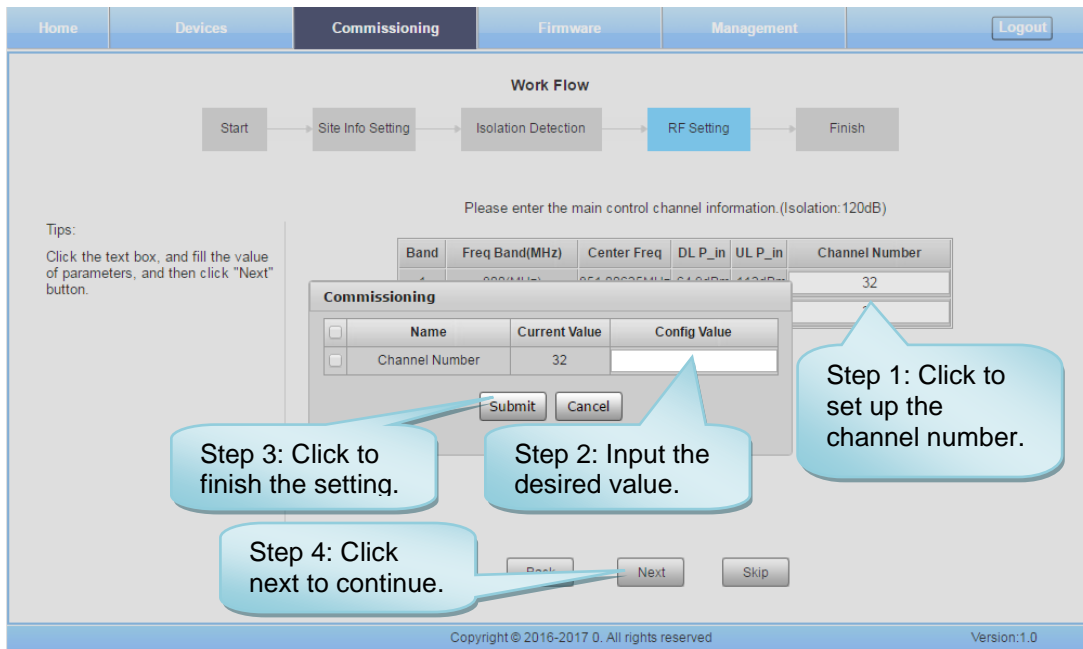



Figure 41: Commissioning Procedure – Channel Number Setting

**Step 7:** Click  to finish the commissioning. In this window, a summary of device setting is shown.

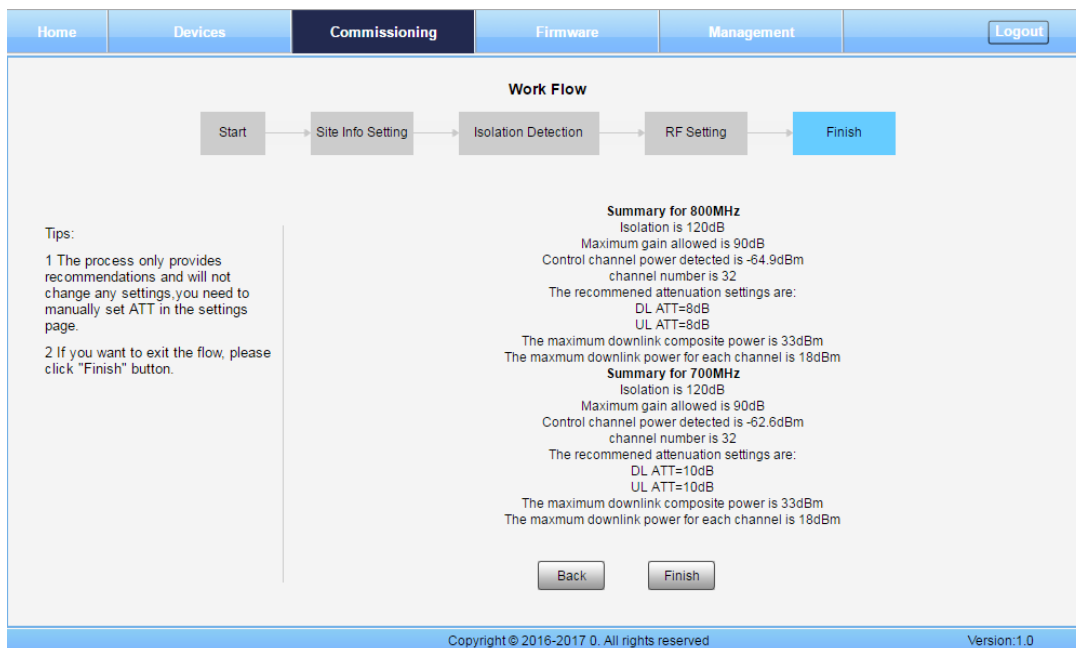

Figure 42: Commissioning Procedure – Finish

End of Section

## 6 MAINTENANCE

The PS BDA is designed for trouble-free operation and generally does not need maintenance. Maintenance activities should only be carried out by trained personnel.

Periodic inspection of the repeater equipment(s) is recommended, the recommended tasks includes:

- Verify the direction and position of antennas. Re-align if necessary.
- Make sure the cable connector and sealing on the RF cable connectors are not damaged.
- Verify lightning and grounding protection is in good condition.

End of Section

## 7 APPENDICES

### 7.1 APPENDIX A: TOOLS

The following are the recommended list of tools for new installation and routine maintenance.

- Slotted Screwdriver
- Philips Screwdriver
- Ring Spanner (Assorted size: 12~20mm)
- Electrically operated drill and masonry drill bits  $\varnothing$ 12mm
- Anti-static Wrist Strap
- Side Cutter
- Frequency Counter (e.g. FLUKE PM6685R)
- RF Power Meter (e.g. Bird 5000)

## 7.2 APPENDIX B: DECLARATION OF HARMFUL SUBSTANCES AND CONTENT

**Product Name: Public Safety BDA**

**Model: RX-7W22**

Harmful substance and content of this product as below table shown:

Part Name	Harmful Substance					
	Pb	Hg	Cd	Cr (VI)	PBB	PBDE
A	×	○	○	○	○	○
B	×	○	○	○	○	○

**Note:** Above table complies with SJ/T 11364.

○: Indicates that the harmful substance content in all homogeneous materials for corresponding part is under the limited requirement of GB/T 26572.

×: Indicates that the harmful substance content in at least one single homogeneous material for the corresponding part exceeds the limited requirement of GB/T 26572.

**Remark:** The content of the parts marked with “×”above exceeds the requirement as there is still no mature alternative technologies to achieve the replacement of poisonous and harmful materials or elements.

### 7.3 APPENDIX C: LICENSE SWITCH QUICK GUIDE

For CriticalPoint BDA, users are able to switch the configuration anytime by changing the license in the WEBOMT. There are 3 difference licenses: 700MHz single band license, 800MHz single band license and 700MHz/800MHz dual band license.

Both 700MHz and 800MHz single band licenses are provided with a single band unit. Users can switch between 700MHz configuration and 800MHz configuration. To upgrade from single band to dual band configurations, users need to purchase the dual band upgrade license..

If the equipment is in dual band originally, no license will be provided, because the equipment already comes with dual band activated.

Please follow the steps to switch configuration by license:

**Step 1:** Connect the unit “OMT port” to a laptop with an Ethernet cable.

**Step 2:** Wait approximately 1 minute until the IP address is established. Open the browser (Chrome or Firefox is recommended), login to WEBGUI with: [www.combaomt.com](http://www.combaomt.com) or 192.168.8.101.

**Step 3:** Input User Name: admin; Password: (default: admin). Click [Log in].



Figure 43: Input User Name and Password



**Step 4:** Go to Management -> License as shown in figure blow. Input the license code in the License field and click submit to continue. The license code is presented as a label on the equipment.

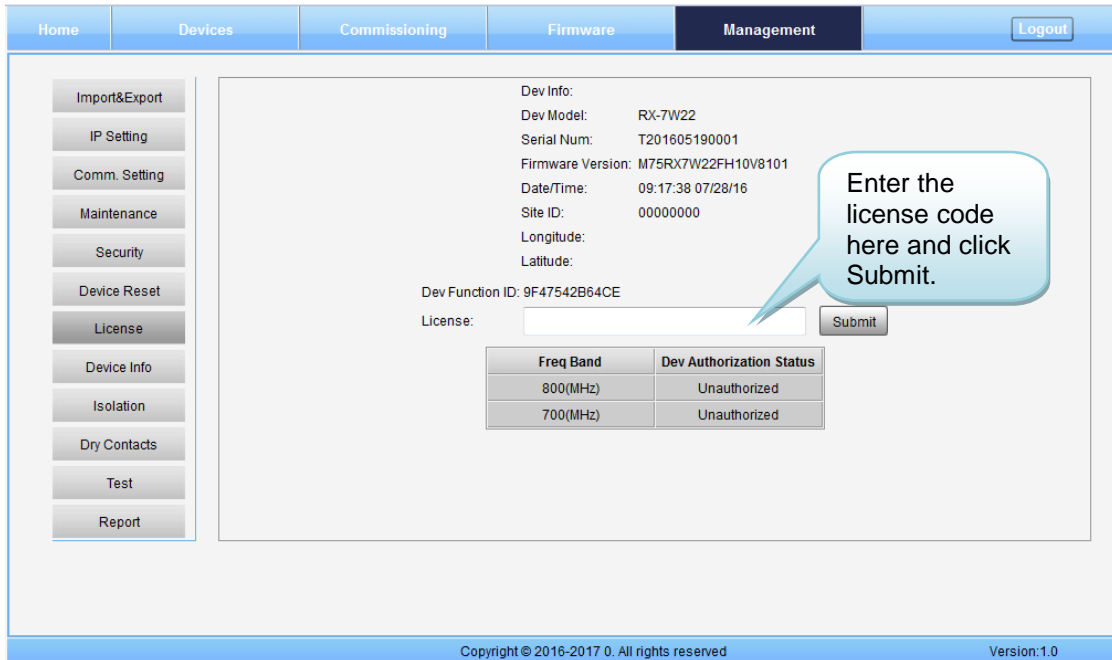

Figure 44: Input License Code

**Step 5:** Refresh the page from the browser, and if the Dev Authorization Status shows the specific band is authorized, it means the license switch was successful.

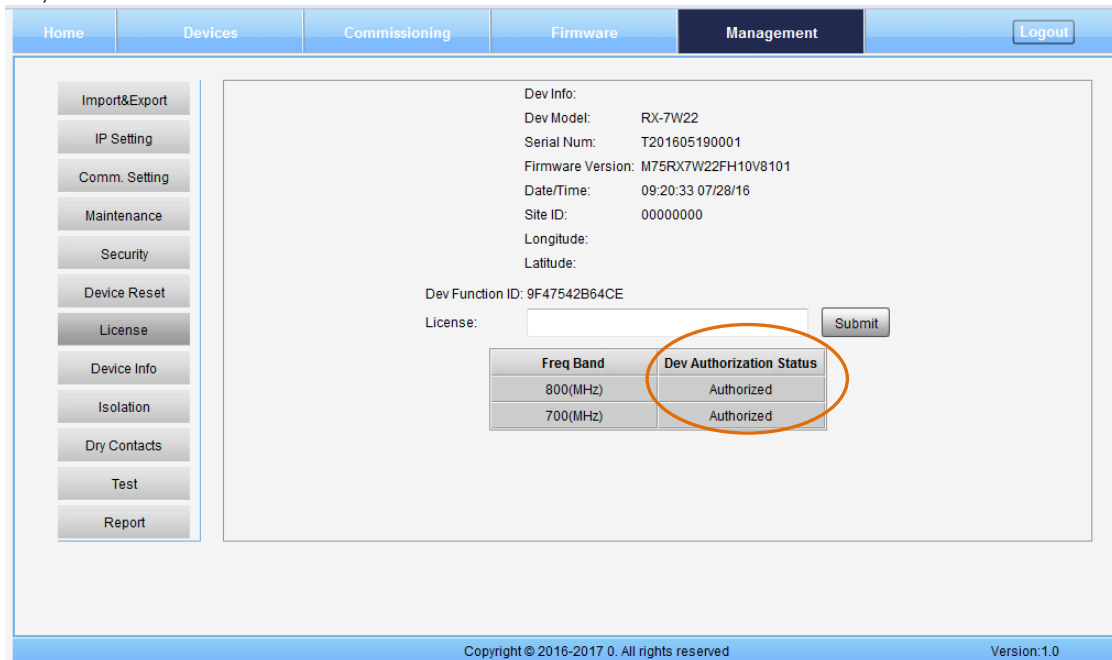

Figure 45: License switch success

7.4 APPENDIX D: TROUBLESHOOTING QUICK GUIDE

Alarm list:

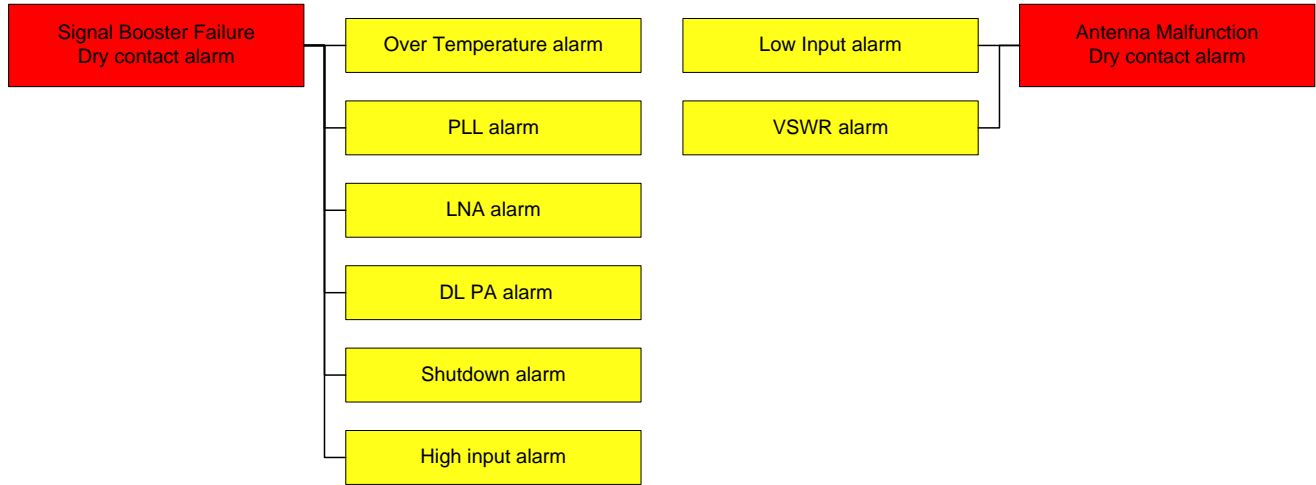

Figure 46: Alarm list

Troubleshooting:

Alarms	Causes and actions
<b>Low input (for DT port)</b>	DT composite input power lower than -80dBm will trigger the alarm 1. Donor antenna/passive system failure 2. Wrong channel frequency setting 3. Site is not commissioned yet
<b>VSWR</b>	Service antenna/passive system failure
<b>Over temperature</b>	Environment temperature shall be lower than 140degF (60degC)
<b>PLL (Phase lock loop)</b>	Hardware failure, RMA the equipment
<b>LNA (Low noise amp.)</b>	Hardware failure, RMA the equipment 1. Handling RF connectors when RF power is ON may damage LNA 2. High power injection to DT/MT port may damage LNA
<b>DL PA (Downlink amp.)</b>	Fix any other existing alarms first, then reset PA (see next page) If alarm still exists, RMA the equipment
<b>Shutdown</b>	Other critical alarm causes the equipment shutdown Follow instructions to fix other alarms first
<b>High input (for DT port)</b>	Check input power to DT port, the power shall be lower than -30dBm 1. Avoid other inference 2. Put attenuator between antenna and PS BDA, if donor signal is high

**Reset PA:**

The Downlink PA will try to automatically reboot during the first 2 hours after alarms occur and then may shutdown permanently if alarms still exist. Users need to manually reset the PA in WEBOMT after fixing the alarm.

Go to Management -> Device Reset: Click the Reset button at the lower table to reset DL PA for 800MHz or 700MHz

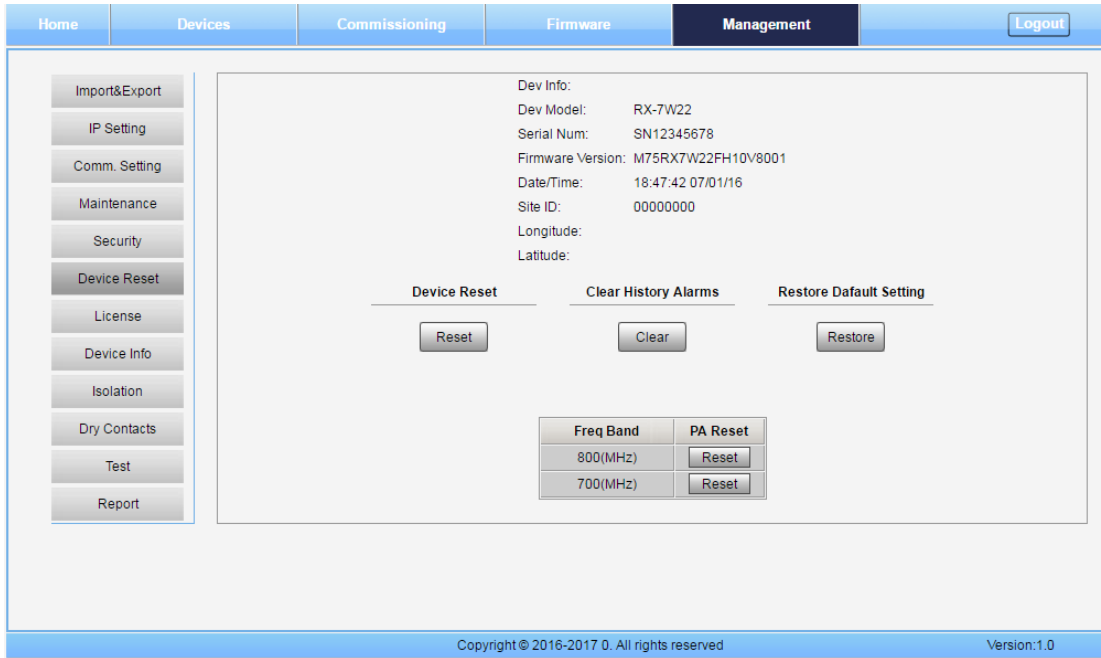

Figure 47: Reset PA

**Power detection:**

- The power detection can be done from the reading number in WEBOMT, available in:
  - Downlink input power (per channel)
  - Downlink output power (composite)
  - Uplink input power (per channel)
- Or from the test ports for DT/MT, which are 22dB lower than the DT/MT port respectively, the test ports are able to detect both DL and UL signals

**Isolation:**

The system doesn't allow users to set a gain higher than **isolation-20dB**. The PS BDA has a mandatory process to check the isolation during commissioning, when isolation is not good (lower than 110dB, even though the PS BDA passes the commissioning process), a check on isolation (between donor and service antennas) is always recommended.

The maximum system gain that can be set must be 20dB lower than the isolation. (For example, if the isolation is 110dB, then the maximum gain that can be set is 90dB.) The PS BDA has an automatic process that prevents the gain being set to a value that does not follow this parameter.

If this gain is insufficient, then the isolation situation must be corrected to provide a higher isolation value.

**Safety operation to protect the LNA (low noise amplifier):**

1. Connect RF cables before powering on.
2. Any changes or handling of the RF connection requires user to switch off RF power (RF switch off in WEBOMT) or power off the unit first.

## 7.5 APPENDIX E: DEVICE REPORT EXAMPLE

### Device Report

Created Time: 10:47:37 08/17/16

Table1 Basic Info

Dev Model	RX-7W22	Dev Info	
Site ID	00000000	Firmware Version	M75RX7W22FH10V8201
Uptime	1:41:44 0/0/0	RF Unit Alm	Normal
Temperature	37	Over Temperature Alm	Normal
Serial Num	T201605190001		

Table2 Overview RF Info

Slave	Freq Band	DL P_out	RF Switch	PLL	LNA	DL PA	VSWR	High Input	Low Input	Shutdown	PA Status	Isolation
1	800(MHz)	-2dBm	ON	Normal	Normal	Normal	Normal	Normal	Disable	Normal	Normal	120dB
2	700(MHz)	26dBm	ON	Normal	Normal	Normal	Normal	Normal	Disable	Normal	Normal	120dB

Table3 Sub Band RF Info

Freq Band	Sub Band	Center Freq	BandWidth	DL P_in	UL P_in	Switch	UL ATT	DL ATT	UL Gain	DL Gain
800(MHz)	1	851.00625MHz	25KHz	-64.8dBm	-112dBm	ON	28dB	28dB	62dB	62dB
	2	860.00625MHz	12.5KHz	-106dBm	-112dBm	OFF	30dB	30dB	60dB	60dB
	3	868.99375MHz	12.5KHz	-106dBm	-112dBm	OFF	30dB	30dB	60dB	60dB
	4	851.15625MHz	12.5KHz	-106dBm	-112dBm	OFF	30dB	30dB	60dB	60dB
	5	851.30625MHz	12.5KHz	-106dBm	-112dBm	OFF	30dB	30dB	60dB	60dB
	6	851.45625MHz	12.5KHz	-106dBm	-112dBm	OFF	30dB	30dB	60dB	60dB
	7	859.85625MHz	12.5KHz	-106dBm	-112dBm	OFF	30dB	30dB	60dB	60dB
	8	860.15625MHz	12.5KHz	-106dBm	-112dBm	OFF	30dB	30dB	60dB	60dB
	9	860.30625MHz	12.5KHz	-106dBm	-112dBm	OFF	30dB	30dB	60dB	60dB
	10	868.54375MHz	12.5KHz	-106dBm	-112dBm	OFF	30dB	30dB	60dB	60dB
	11	868.69375MHz	12.5KHz	-106dBm	-112dBm	OFF	30dB	30dB	60dB	60dB
	12	868.84375MHz	12.5KHz	-106dBm	-112dBm	OFF	30dB	30dB	60dB	60dB
	13	852.00625MHz	12.5KHz	-106dBm	-112dBm	OFF	30dB	30dB	60dB	60dB
	14	853.00625MHz	12.5KHz	-106dBm	-112dBm	OFF	30dB	30dB	60dB	60dB
	15	854.00625MHz	12.5KHz	-106dBm	-112dBm	OFF	30dB	30dB	60dB	60dB
	16	855.00625MHz	12.5KHz	-106dBm	-112dBm	OFF	30dB	30dB	60dB	60dB
	17	856.00625MHz	12.5KHz	-106dBm	-112dBm	OFF	30dB	30dB	60dB	60dB
	18	857.00625MHz	12.5KHz	-106dBm	-112dBm	OFF	30dB	30dB	60dB	60dB
	19	858.00625MHz	12.5KHz	-106dBm	-112dBm	OFF	30dB	30dB	60dB	60dB
	20	859.00625MHz	12.5KHz	-106dBm	-112dBm	OFF	30dB	30dB	60dB	60dB
	21	861.00625MHz	12.5KHz	-106dBm	-112dBm	OFF	30dB	30dB	60dB	60dB
	22	862.00625MHz	12.5KHz	-106dBm	-112dBm	OFF	30dB	30dB	60dB	60dB
	23	863.00625MHz	12.5KHz	-106dBm	-112dBm	OFF	30dB	30dB	60dB	60dB
	24	864.00625MHz	12.5KHz	-106dBm	-112dBm	OFF	30dB	30dB	60dB	60dB
	25	865.00625MHz	12.5KHz	-106dBm	-112dBm	OFF	30dB	30dB	60dB	60dB
	26	866.00625MHz	12.5KHz	-106dBm	-112dBm	OFF	30dB	30dB	60dB	60dB
	27	867.00625MHz	12.5KHz	-106dBm	-112dBm	OFF	30dB	30dB	60dB	60dB
	28	868.00625MHz	12.5KHz	-106dBm	-112dBm	OFF	30dB	30dB	60dB	60dB
	29	864.50625MHz	12.5KHz	-106dBm	-112dBm	OFF	30dB	30dB	60dB	60dB
	30	865.50625MHz	12.5KHz	-106dBm	-112dBm	OFF	30dB	30dB	60dB	60dB
	31	866.50625MHz	12.5KHz	-106dBm	-112dBm	OFF	30dB	30dB	60dB	60dB
	32	867.50625MHz	12.5KHz	-106dBm	-112dBm	OFF	30dB	30dB	60dB	60dB

Current Page: 1 (Total Pages: 2)

7.6 APPENDIX F: RMA (RETURN MATERIAL AUTHORIZATION)



**Comba Telecom Ltd.**  
 611 East Wing, No. 8 Science Park West Avenue, Hong Kong Science Park, Tai Po, Hong Kong  
 Tel: +852 2636 6861 Fax: +852 2637 0966

**RMA Request Form**  
 Date: \_\_\_\_\_

From: \_\_\_\_\_  
 Address: \_\_\_\_\_  
 Tel: \_\_\_\_\_ Fax: \_\_\_\_\_  
 E-Mail: \_\_\_\_\_  
 ATTN: \_\_\_\_\_

**Product Information:**

Item	Model	Serial Number	Return Category	Qty	Problem Description
1					
2					
3					
4					
5					
6					
7					
8					
9					
10					

**Notes:**  
 1. For 'Return Category' column, please select from **A:** Return of Defective Product, **B:** Return of Trial Sample, or **C:** Return of New and Unused Product.  
 2. If **A** or **C** category of return product is chosen, please give short description of the problem or reason for returning.

**Transportation Information:**  
 Location of Product: \_\_\_\_\_  
 Transportation Method: \_\_\_\_\_  
 Shipping Forwarder: \_\_\_\_\_

**Note:** Location of Product must be stated, while 'Transportation Method' or 'Shipping Forwarder' can be left blank if not determined.

**Signature:**  
 \_\_\_\_\_

---

**For Comba Use (Only)**  
 Return Merchandise Authorization Number (RMA#): \_\_\_\_\_  
 Recommended Action: \_\_\_\_\_  
 Shipment and Handling Cost to be paid by: \_\_\_\_\_

Approved by: \_\_\_\_\_  
 \_\_\_\_\_

Date: \_\_\_\_\_

End of Section

End of Document



## Comba Telecom Inc.

235 Charcot Ave, San Jose, CA 95131, USA

Tel: +1 866 802 7961

Fax: +1 408 526 0181

Email: [customer.nam@comba-telecom.com](mailto:customer.nam@comba-telecom.com)

[www.combausea.com](http://www.combausea.com)