

11.2.3.1.4. Analog FM

11.2.3.1.4.1. Downlink

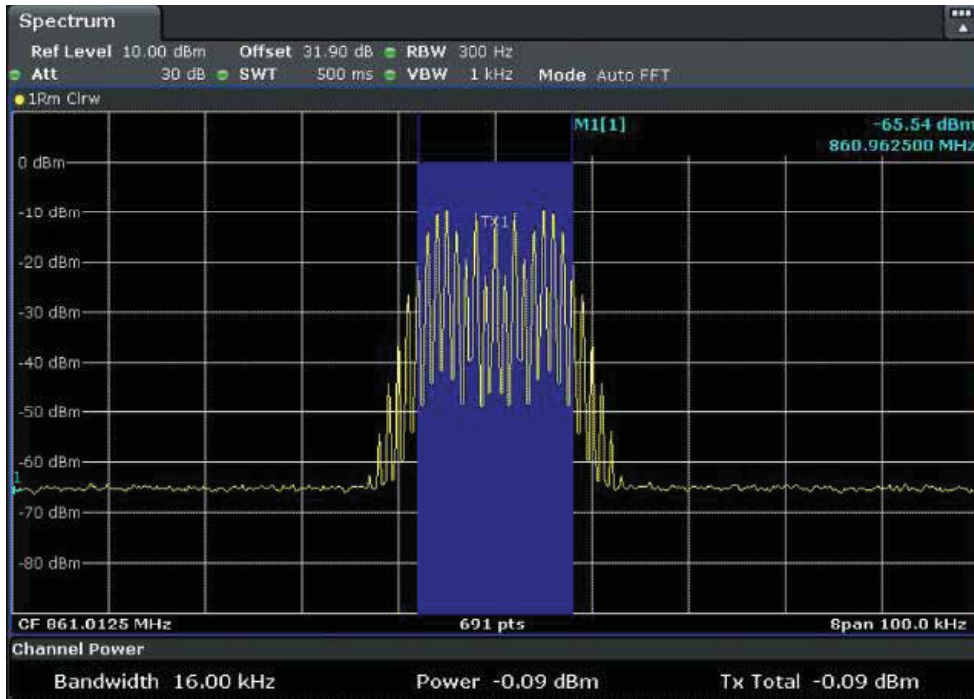

Low Frequency: 861.0125MHz

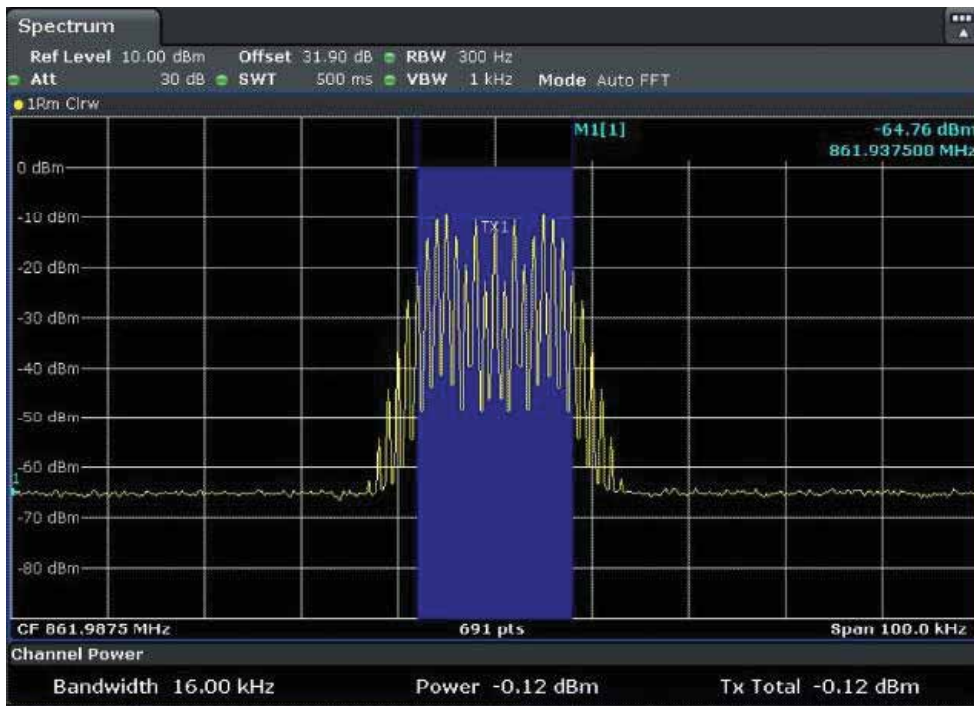

High Frequency: 861.9875MHz

11.2.3.1.4.2. Uplink

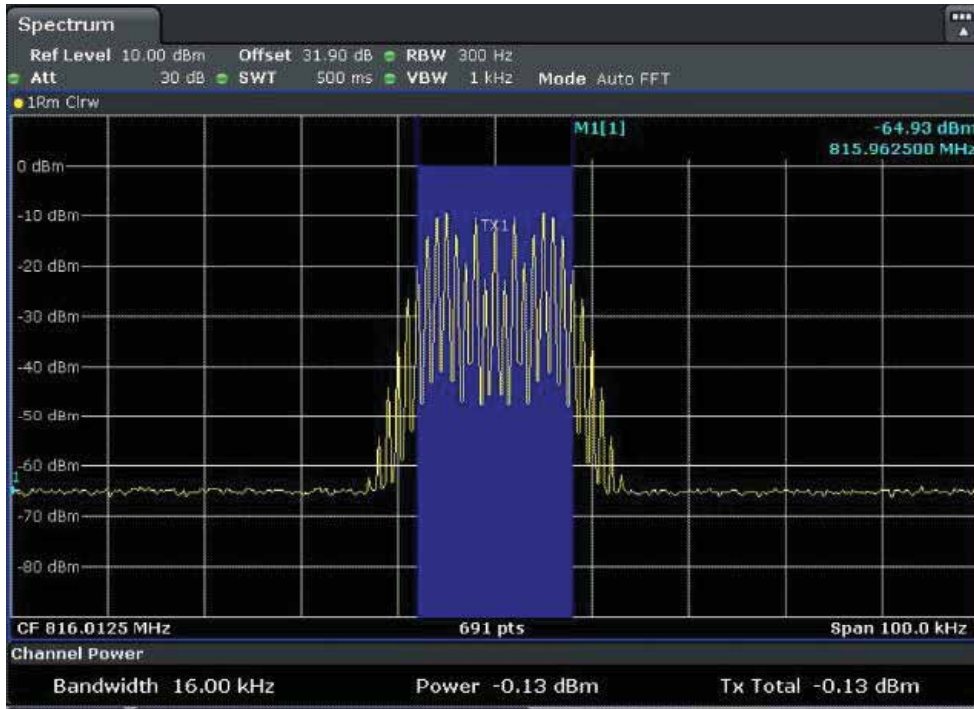

Low Frequency: 816.0125MHz

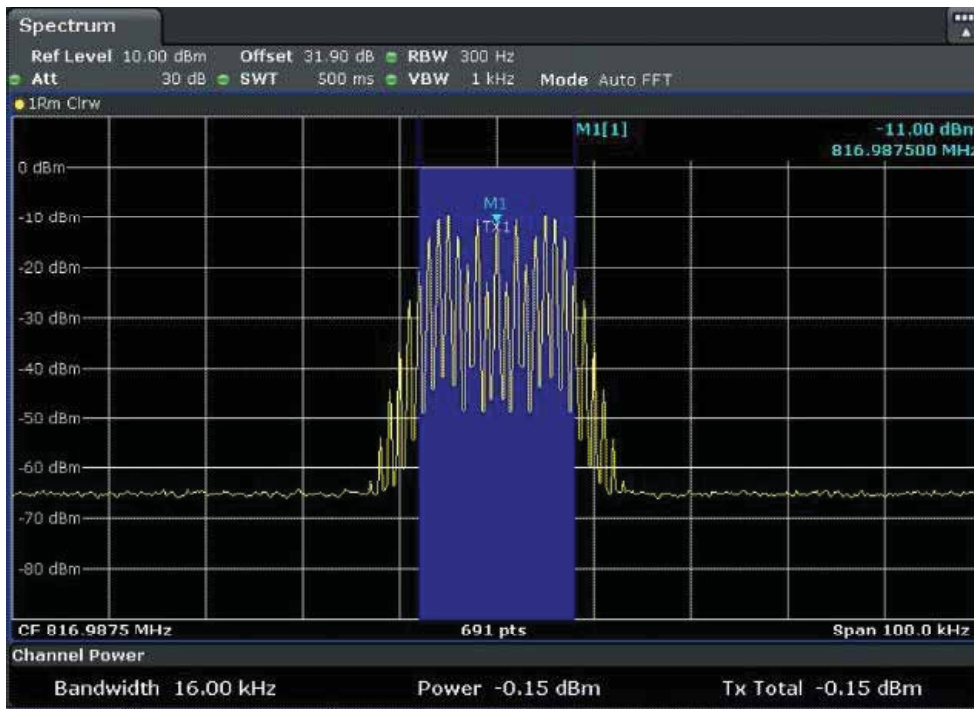

High Frequency: 816.9875MHz

11.2.3.1.5. Tetra

11.2.3.1.5.1. Downlink

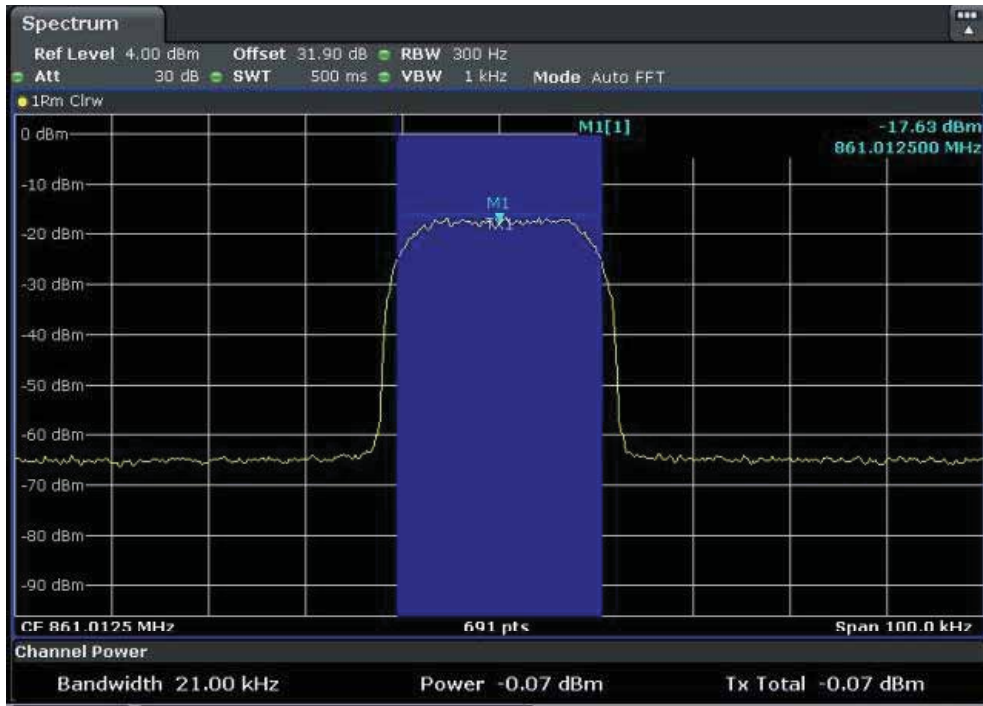

Low Frequency: 861.0125MHz

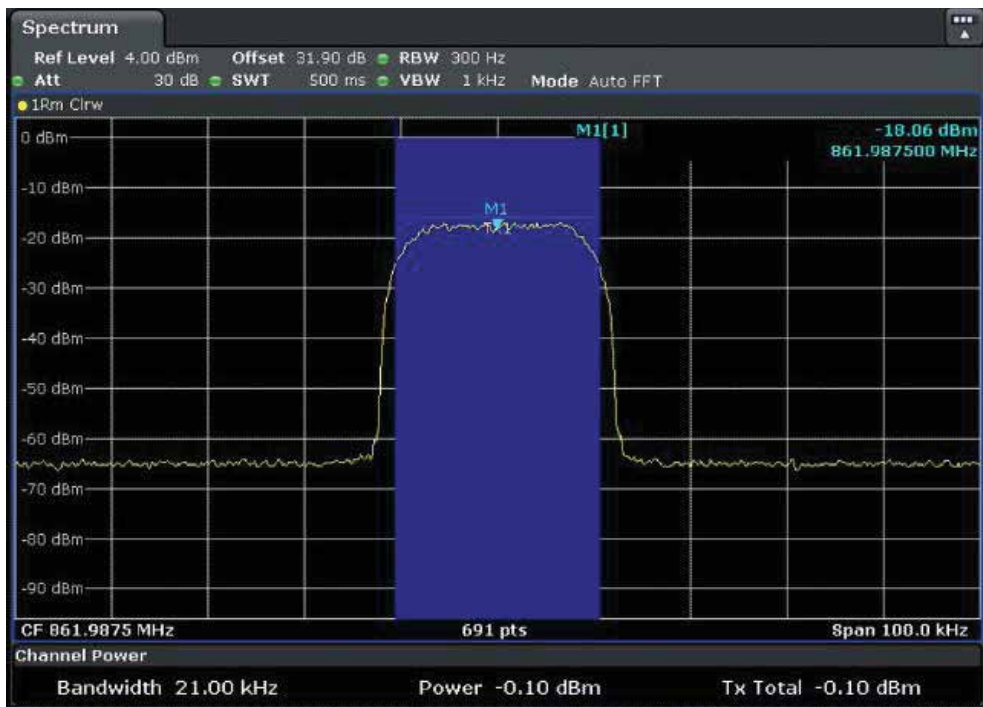

High Frequency: 861.9875MHz

11.2.3.1.5.2. Uplink

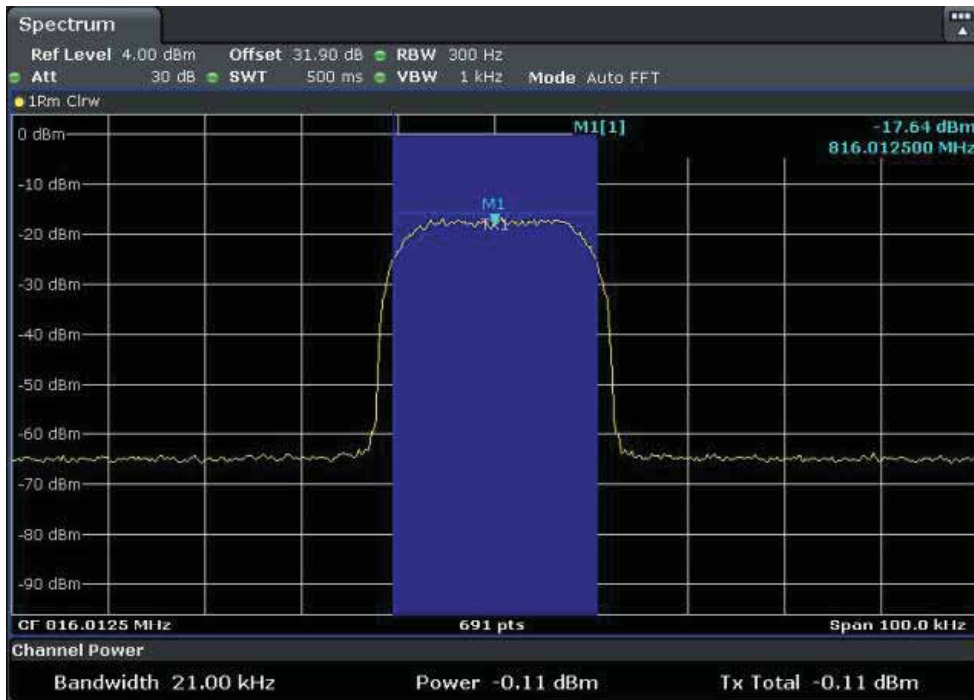

Low Frequency: 816.0125MHz

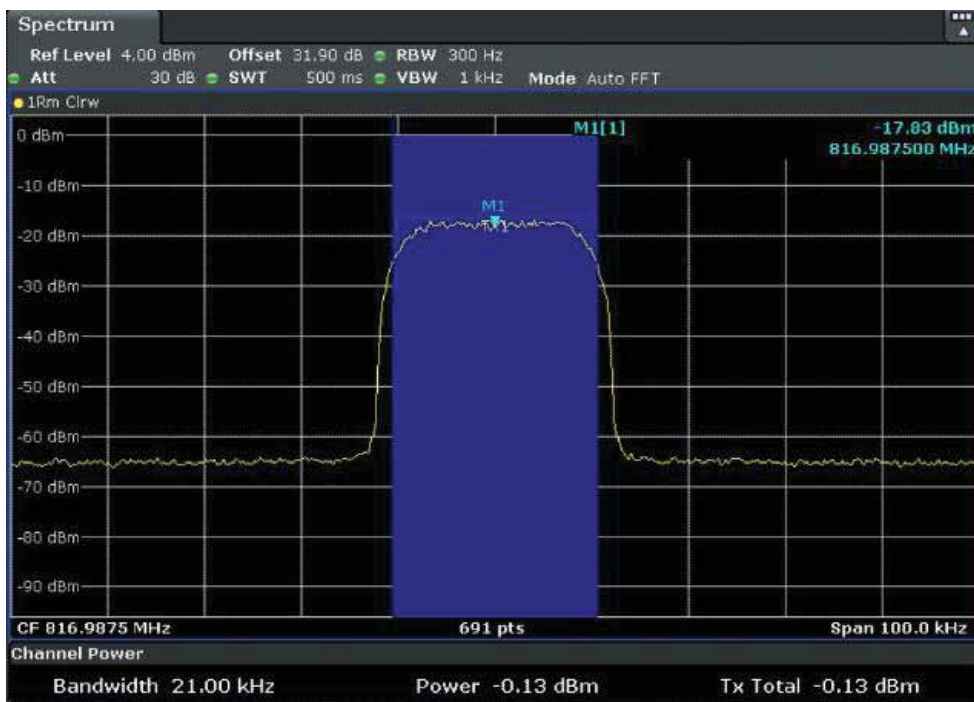

High Frequency: 816.9875MHz

----- The following blanks -----

11.3. AGC Threshold

Requirements: KDB 935210 D05 clause 4.2

Test Method: KDB 935210 D05 clause 3.2

11.3.1. Requirements

Testing at and above the AGC threshold will be required.⁶ The AGC threshold shall be determined by applying the procedure of 3.2, but with the signal generator configured to produce a test signal defined in Table 1, a CW input signal, or a digitally modulated signal, consistent with the discussion about signal types in 4.1.

11.3.2. Test configuration

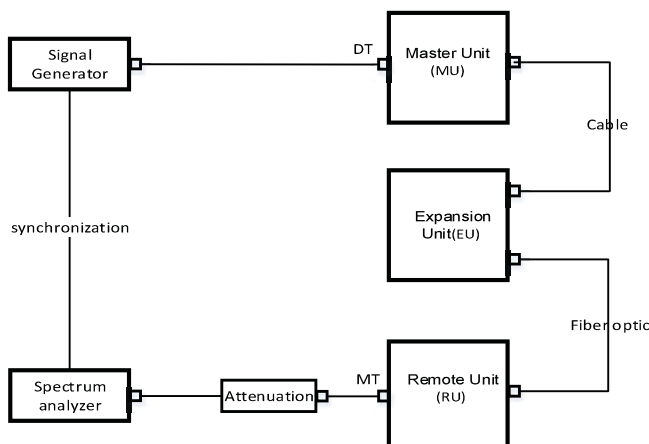

Figure 11.3-1 Downlink connection diagram

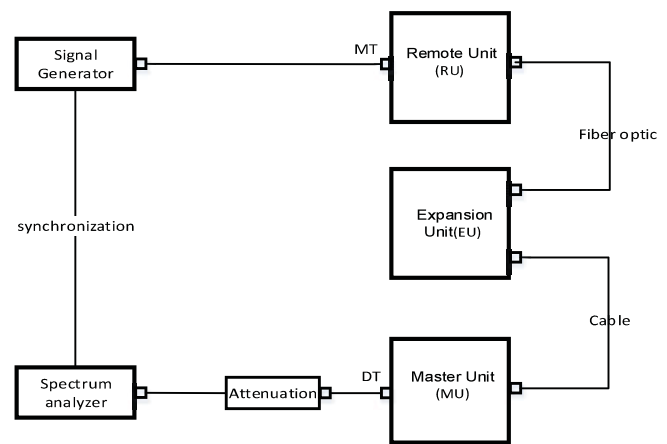

Figure 11.3-2 Uplink connection diagram

11.3.3. Test procedures

The AGC threshold is to be determined as follows.³

In the case of fiber-optic distribution systems, the RF input port of the equipment under test (EUT) refers to the RF input of the supporting equipment RF to optical converter; see also descriptions and diagrams for typical DAS booster systems in KDB Publication 935210 D02 [R7].

Devices intended to be directly connected to an RF source (donor port) only need to be evaluated for any over-the-air transmit paths.

- a) Connect a signal generator to the input of the EUT.
- b) Connect a spectrum analyzer or power meter to the output of the EUT using appropriate attenuation as necessary.
- c) The signal generator should initially be configured to produce either of the required test signals (i.e., broadband or narrowband).
- d) Set the signal generator frequency to the center frequency of the EUT operating band.
- e) While monitoring the output power of the EUT, measured using the methods of 3.5.3 or 3.5.4, increase the input level until a 1 dB increase in the input signal power no longer causes a 1 dB increase in the output signal power.
- f) Record this level as the AGC threshold level.
- g) Repeat the procedure with the remaining test signal.

11.3.4. Test results

Test Date (yy-mm-dd): 2024-05-15

Normal condition: Temp:26.2°C, Humid: 43%, Atmospheric Pressure:101kpa

Supply Voltage: AC 110V, 50Hz

11.3.4.1. 800MHz Band (Downlink: 861MHz ~862MHz, Uplink: 816MHz ~ 817MHz)

11.3.4.1.1. Downlink

11.3.4.1.1.1. P25 Phase I(C4FM)

Test frequency	Signal output power (dBm)	EUT Input cable loss (dB)	EUT Corrected Input power (dBm)	EUT Corrected Output power (dBm)
861.00625MHz	-61.5	1.8	-63.3	26.5
	-60.5	1.8	-62.3	27.5
	-59.5	1.8	-61.3	28.5
	-58.5	1.8	-60.3	29.5
	-57.5	1.8	-59.3	30.5
	-56.5	1.8	-58.3	31.4
	-55.5	1.8	-57.3	31.4
	-54.5	1.8	-56.3	31.4
	-53.5	1.8	-55.3	31.4
	-52.5	1.8	-54.3	31.4
	-51.5	1.8	-53.3	31.4

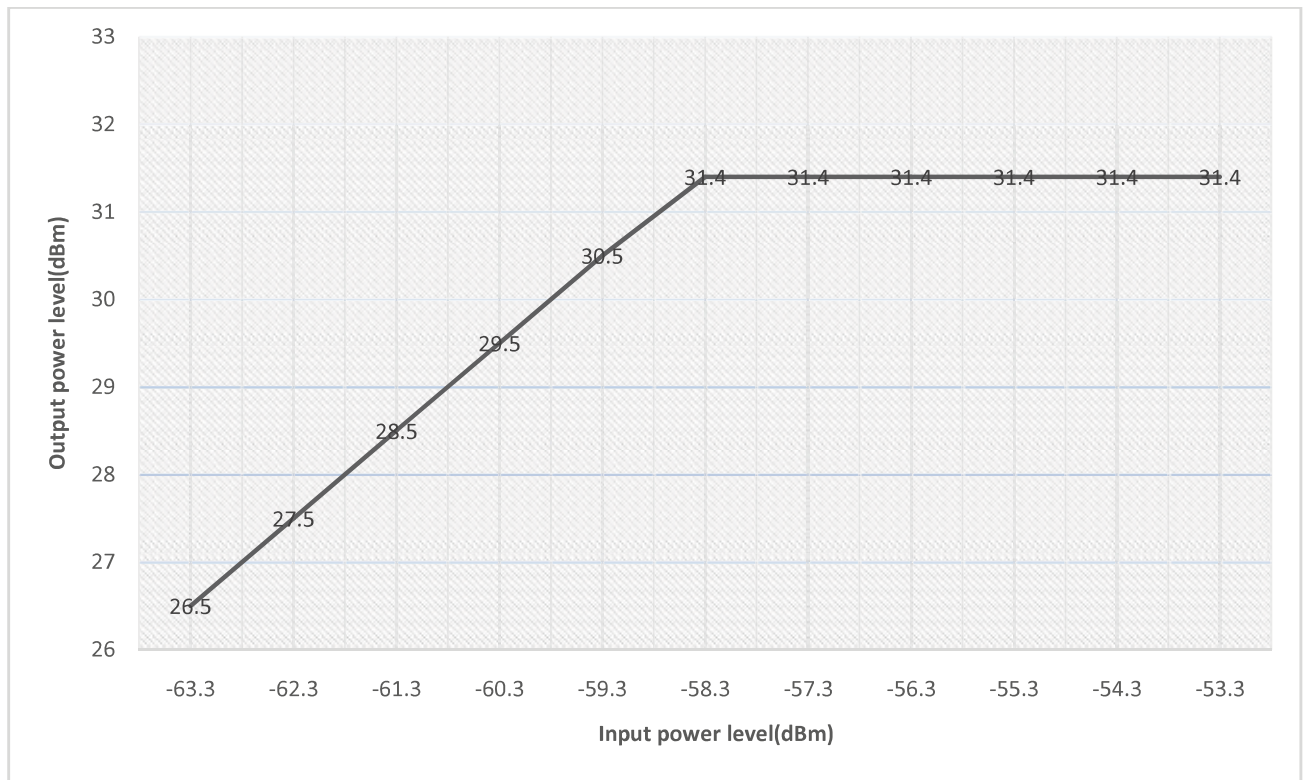

Test frequency	Signal output power (dBm)	EUT Input cable loss (dB)	EUT Corrected Input power (dBm)	EUT Corrected Output power (dBm)
861.99375MHz	-61.5	1.8	-63.3	27.5
	-60.5	1.8	-62.3	28.5
	-59.5	1.8	-61.3	29.5
	-58.5	1.8	-60.3	30.5
	-57.5	1.8	-59.3	31.5
	-56.5	1.8	-58.3	32.4
	-55.5	1.8	-57.3	32.4
	-54.5	1.8	-56.3	32.4
	-53.5	1.8	-55.3	32.4
	-52.5	1.8	-54.3	32.4
	-51.5	1.8	-53.3	32.4

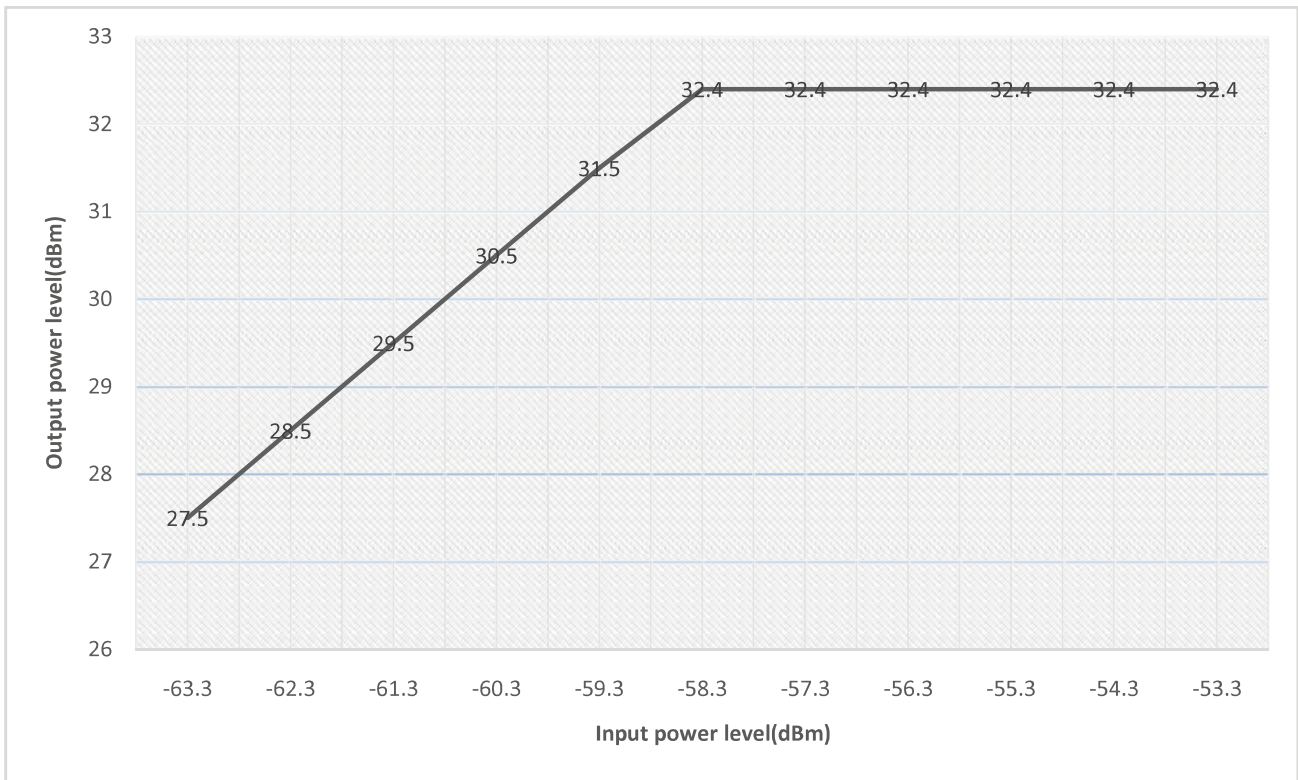

———— The following blanks ————

11.3.4.1.1.2. P25 Phase II(H-DQPSK)

861.00625MHz	-61.5	1.8	-63.3	26.5
	-60.5	1.8	-62.3	27.5
	-59.5	1.8	-61.3	28.4
	-58.5	1.8	-60.3	29.4
	-57.5	1.8	-59.3	30.4
	-56.5	1.8	-58.3	31.4
	-55.5	1.8	-57.3	31.4
	-54.5	1.8	-56.3	31.4
	-53.5	1.8	-55.3	31.4
	-52.5	1.8	-54.3	31.4
	-51.5	1.8	-53.3	31.4

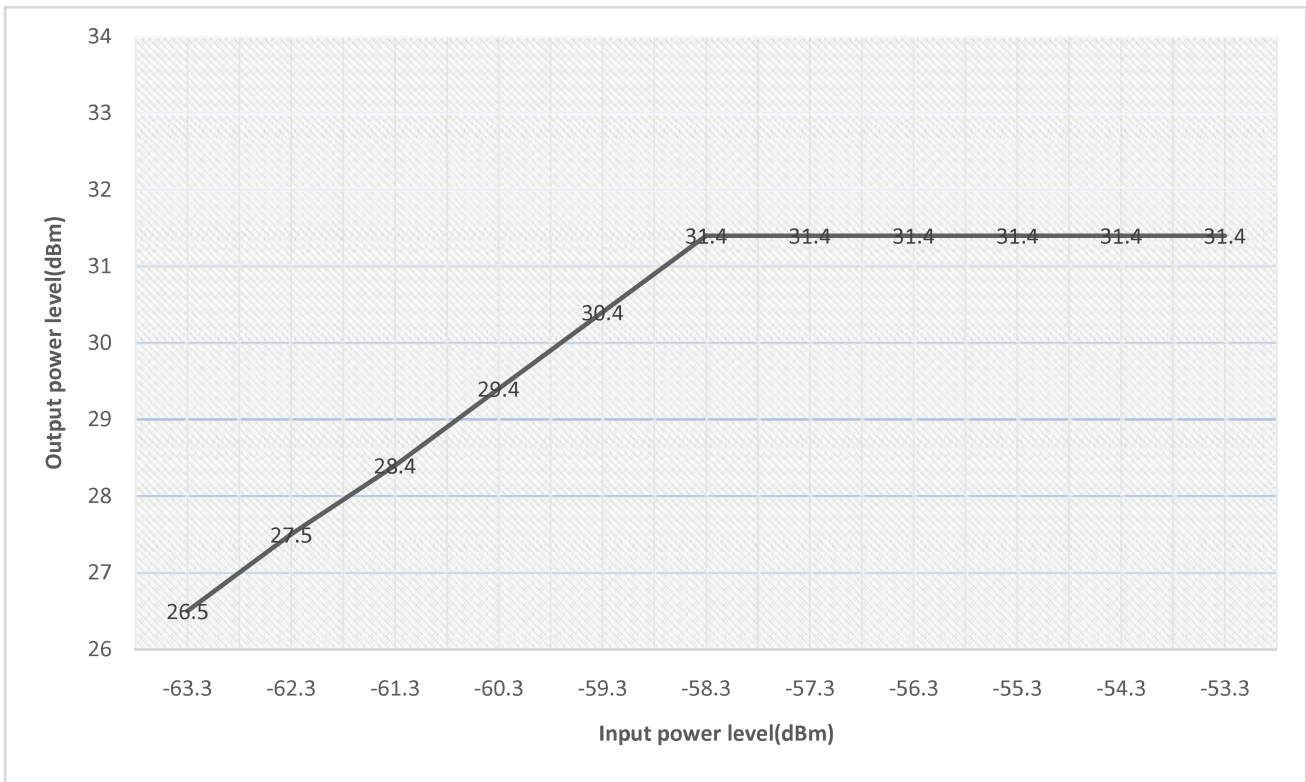

———— The following blanks ————

Test frequency	Signal output power (dBm)	EUT Input cable loss (dB)	EUT Corrected Input power (dBm)	EUT Corrected Output power (dBm)
861.99375MHz	-61.5	1.8	-63.3	27.5
	-60.5	1.8	-62.3	28.5
	-59.5	1.8	-61.3	29.5
	-58.5	1.8	-60.3	30.5
	-57.5	1.8	-59.3	31.5
	-56.5	1.8	-58.3	32.4
	-55.5	1.8	-57.3	32.4
	-54.5	1.8	-56.3	32.4
	-53.5	1.8	-55.3	32.4
	-52.5	1.8	-54.3	32.4
	-51.5	1.8	-53.3	32.4

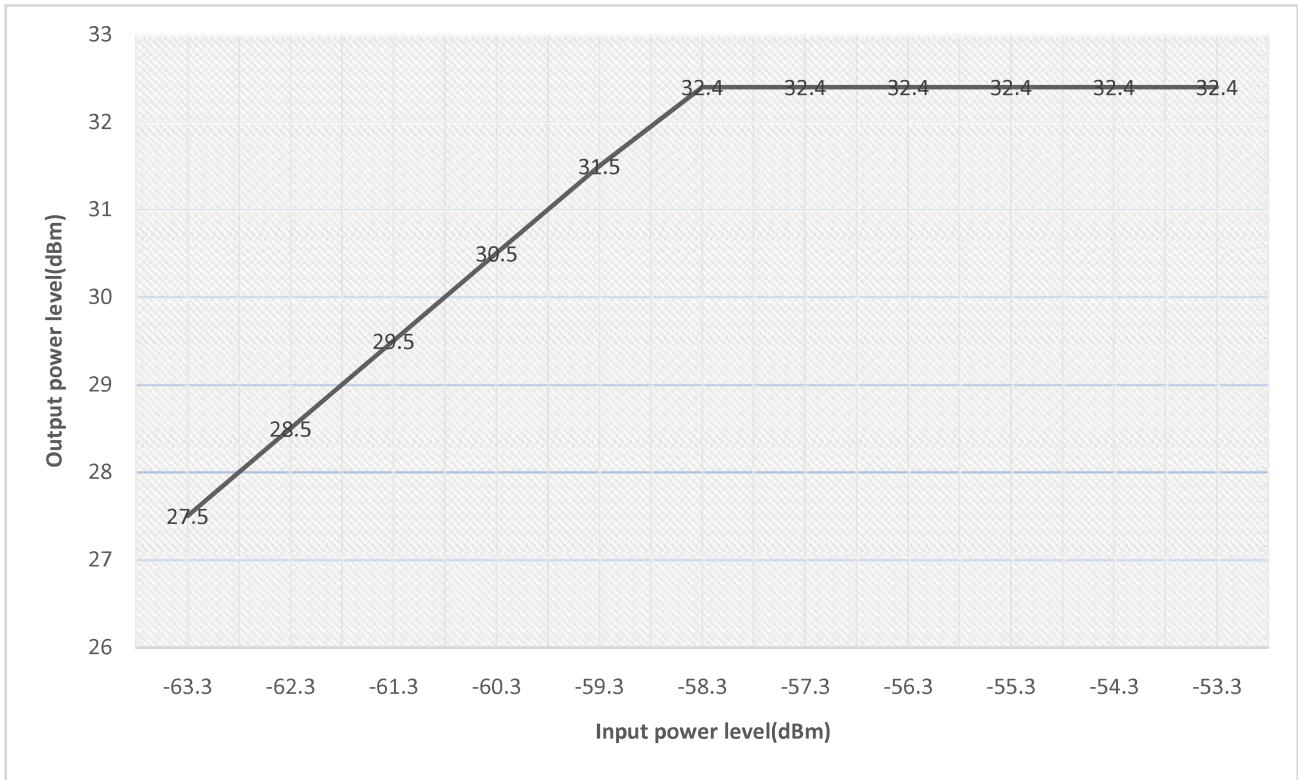

———— The following blanks ————

11.3.4.1.1.3. DMR

861.00625MHz	-61.5	1.8	-63.3	26.5
	-60.5	1.8	-62.3	27.5
	-59.5	1.8	-61.3	28.4
	-58.5	1.8	-60.3	29.4
	-57.5	1.8	-59.3	30.4
	-56.5	1.8	-58.3	31.4
	-55.5	1.8	-57.3	31.4
	-54.5	1.8	-56.3	31.4
	-53.5	1.8	-55.3	31.4
	-52.5	1.8	-54.3	31.4
	-51.5	1.8	-53.3	31.4

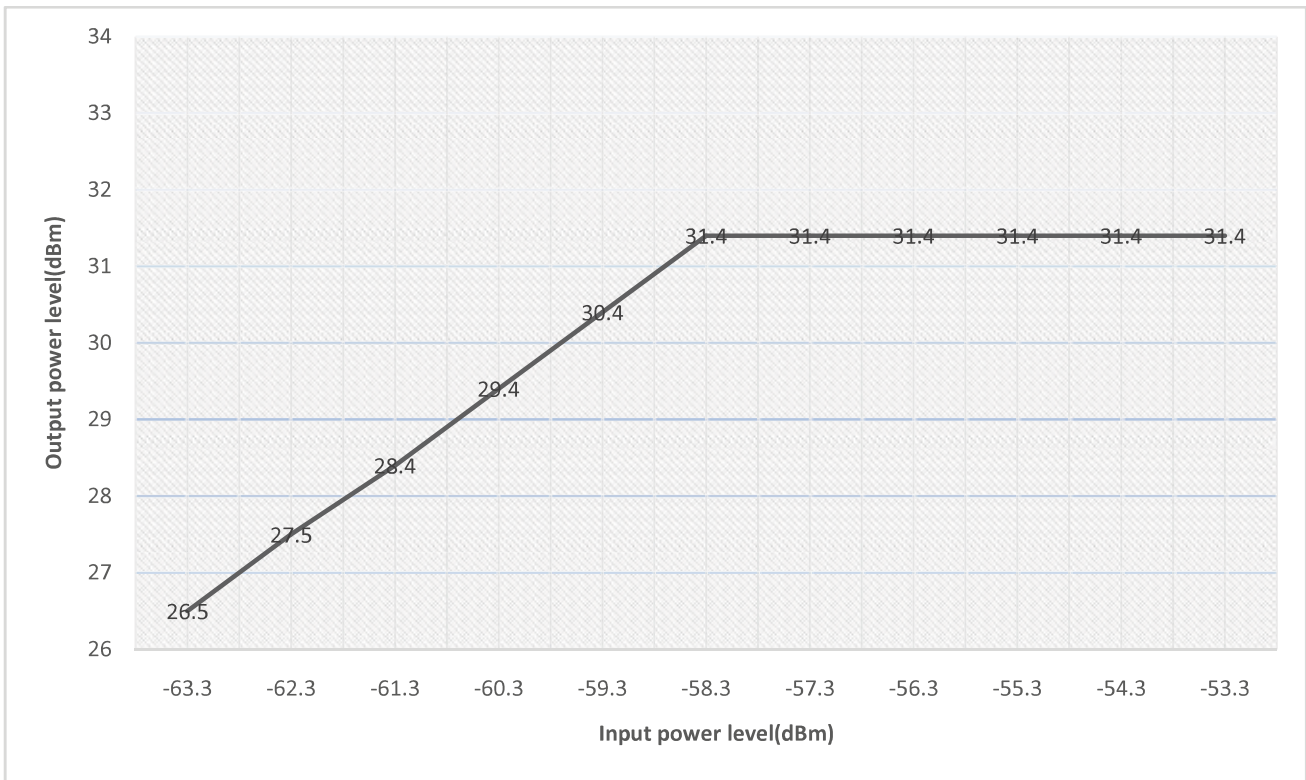

Test frequency	Signal output power (dBm)	EUT Input cable loss (dB)	EUT Corrected Input power (dBm)	EUT Corrected Output power (dBm)
861.99375MHz	-61.5	1.8	-63.3	27.5
	-60.5	1.8	-62.3	28.5
	-59.5	1.8	-61.3	29.5
	-58.5	1.8	-60.3	30.5
	-57.5	1.8	-59.3	31.5
	-56.5	1.8	-58.3	32.4
	-55.5	1.8	-57.3	32.4
	-54.5	1.8	-56.3	32.4
	-53.5	1.8	-55.3	32.4
	-52.5	1.8	-54.3	32.4
	-51.5	1.8	-53.3	32.4

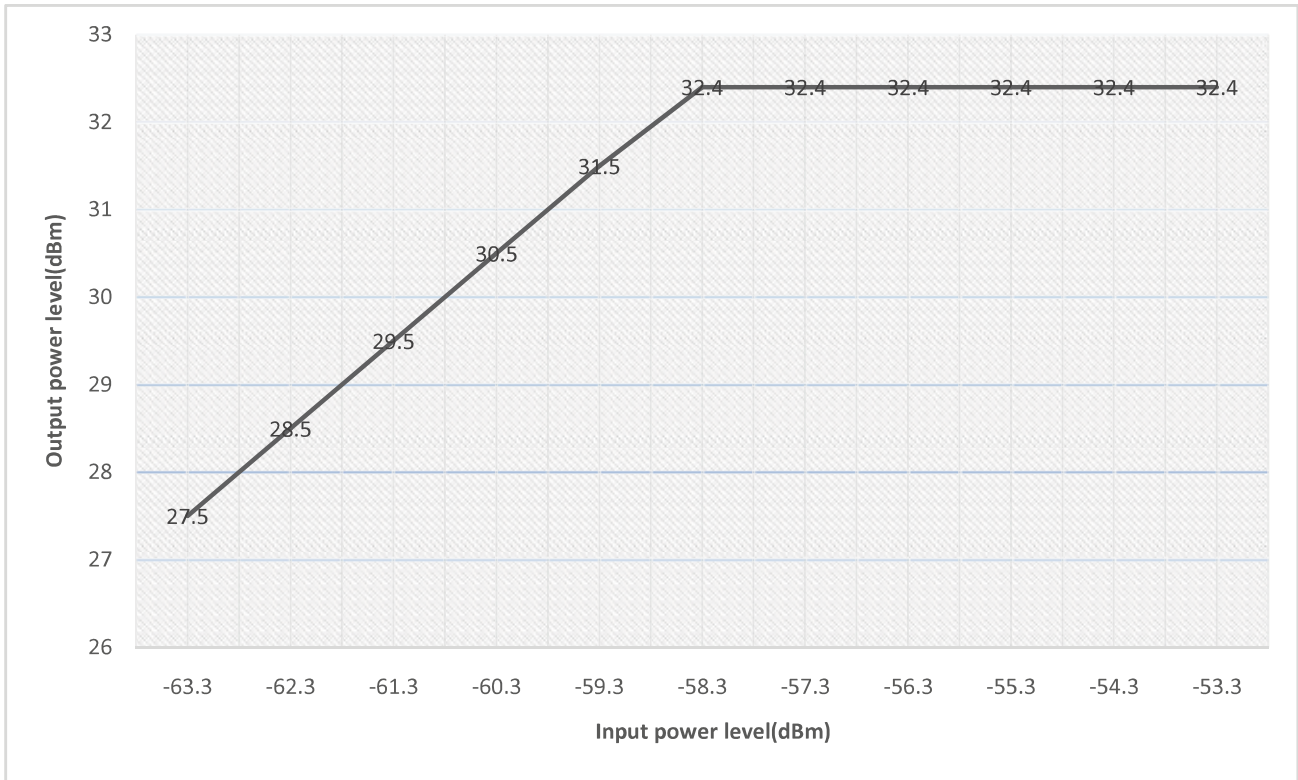

11.3.4.1.1.4. Analog FM

861.0125MHz	-61.5	1.8	-63.3	26.4
	-60.5	1.8	-62.3	27.4
	-59.5	1.8	-61.3	28.4
	-58.5	1.8	-60.3	29.4
	-57.5	1.8	-59.3	30.4
	-56.5	1.8	-58.3	31.4
	-55.5	1.8	-57.3	31.4
	-54.5	1.8	-56.3	31.4
	-53.5	1.8	-55.3	31.4
	-52.5	1.8	-54.3	31.4
	-51.5	1.8	-53.3	31.4

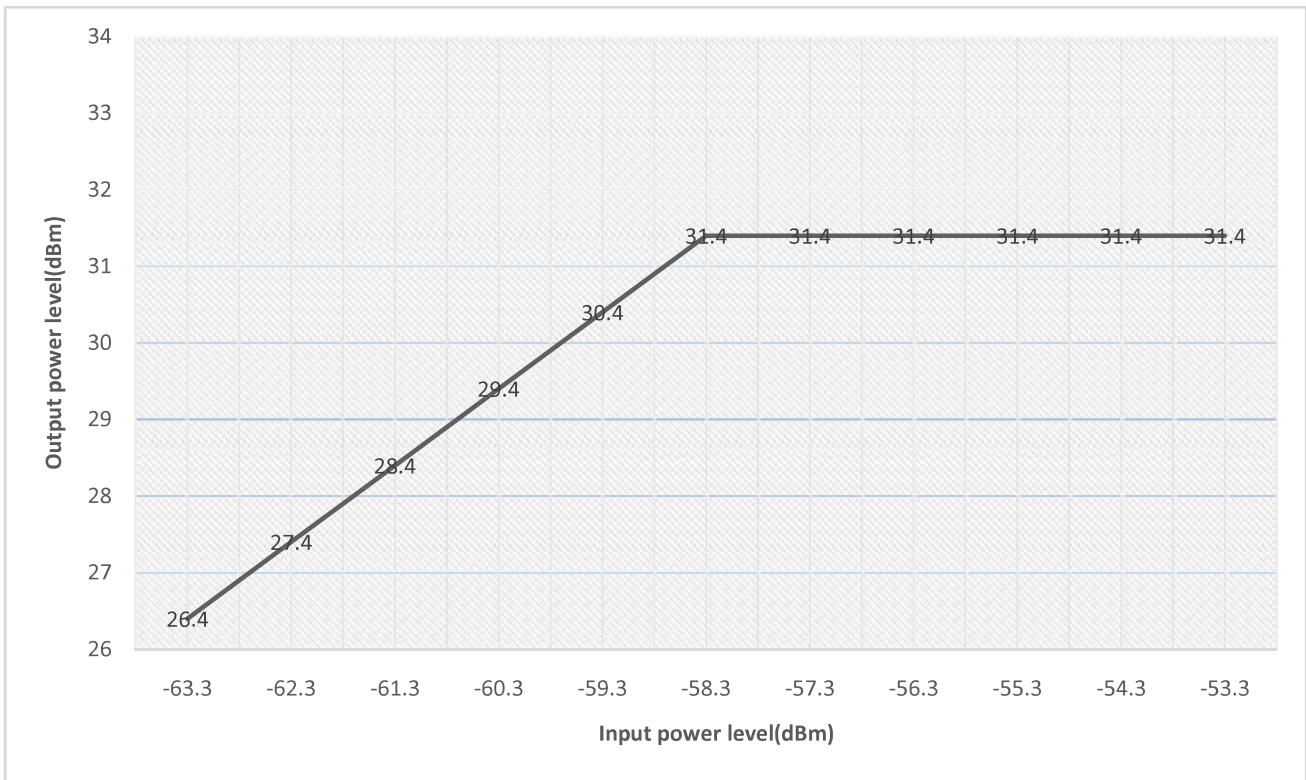

———— The following blanks ————

Test frequency	Signal output power (dBm)	EUT Input cable loss (dB)	EUT Corrected Input power (dBm)	EUT Corrected Output power (dBm)
861.9875MHz	-61.5	1.8	-63.3	27.4
	-60.5	1.8	-62.3	28.4
	-59.5	1.8	-61.3	29.4
	-58.5	1.8	-60.3	30.4
	-57.5	1.8	-59.3	31.4
	-56.5	1.8	-58.3	32.4
	-55.5	1.8	-57.3	32.4
	-54.5	1.8	-56.3	32.4
	-53.5	1.8	-55.3	32.4
	-52.5	1.8	-54.3	32.4
	-51.5	1.8	-53.3	32.4

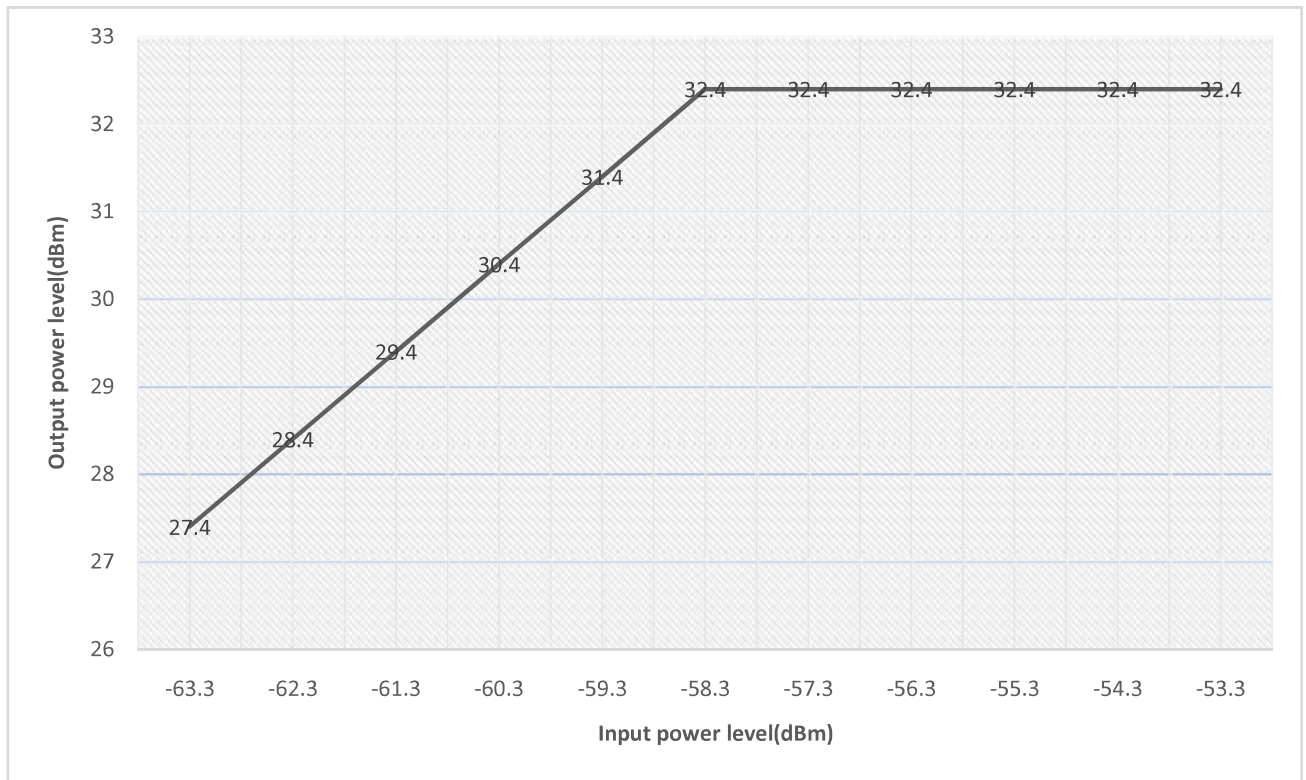

----- The following blanks -----

11.3.4.1.1.5. Tetra

861.0125MHz	-61.5	1.8	-63.3	26.5
	-60.5	1.8	-62.3	27.5
	-59.5	1.8	-61.3	28.4
	-58.5	1.8	-60.3	29.4
	-57.5	1.8	-59.3	30.4
	-56.5	1.8	-58.3	31.4
	-55.5	1.8	-57.3	31.4
	-54.5	1.8	-56.3	31.4
	-53.5	1.8	-55.3	31.4
	-52.5	1.8	-54.3	31.4
	-51.5	1.8	-53.3	31.4

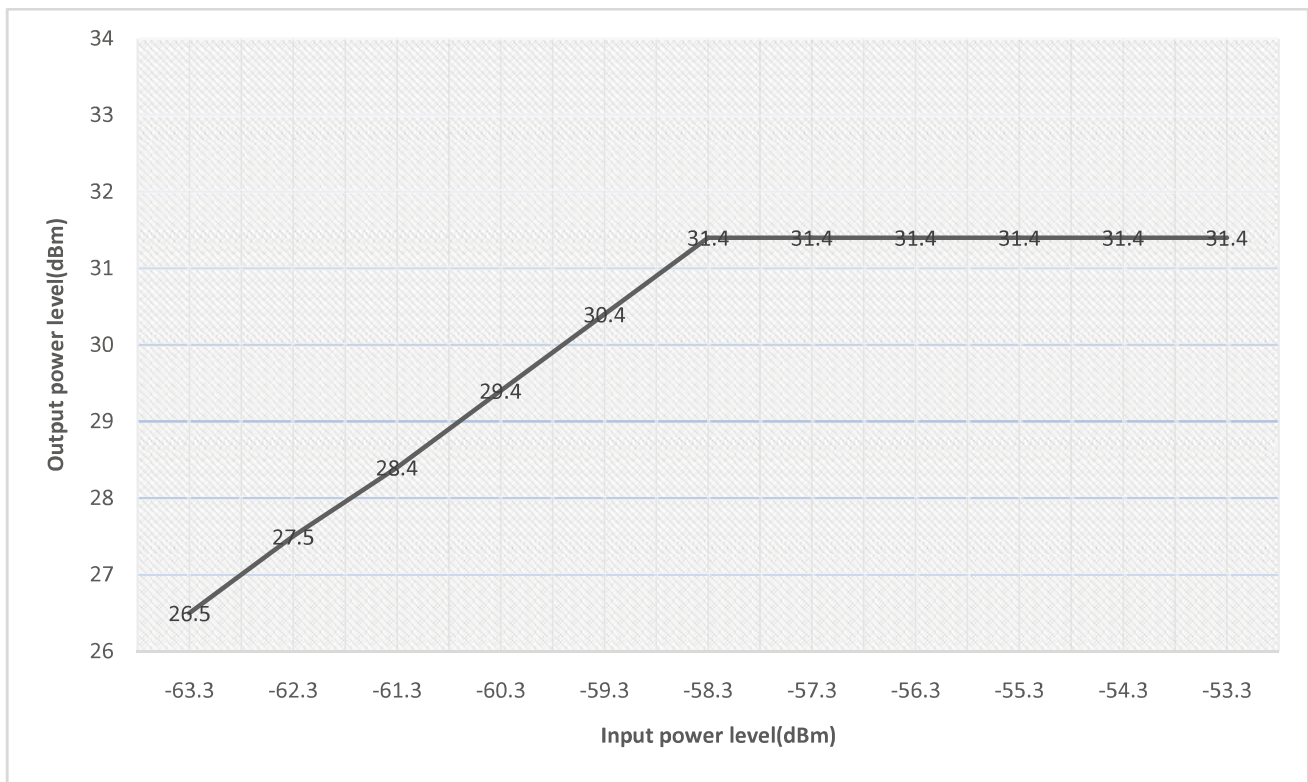

———— The following blanks ————

Test frequency	Signal output power (dBm)	EUT Input cable loss (dB)	EUT Corrected Input power (dBm)	EUT Corrected Output power (dBm)
861.9875MHz	-61.5	1.8	-63.3	27.5
	-60.5	1.8	-62.3	28.5
	-59.5	1.8	-61.3	29.4
	-58.5	1.8	-60.3	30.4
	-57.5	1.8	-59.3	31.4
	-56.5	1.8	-58.3	32.4
	-55.5	1.8	-57.3	32.4
	-54.5	1.8	-56.3	32.4
	-53.5	1.8	-55.3	32.4
	-52.5	1.8	-54.3	32.4
	-51.5	1.8	-53.3	32.4

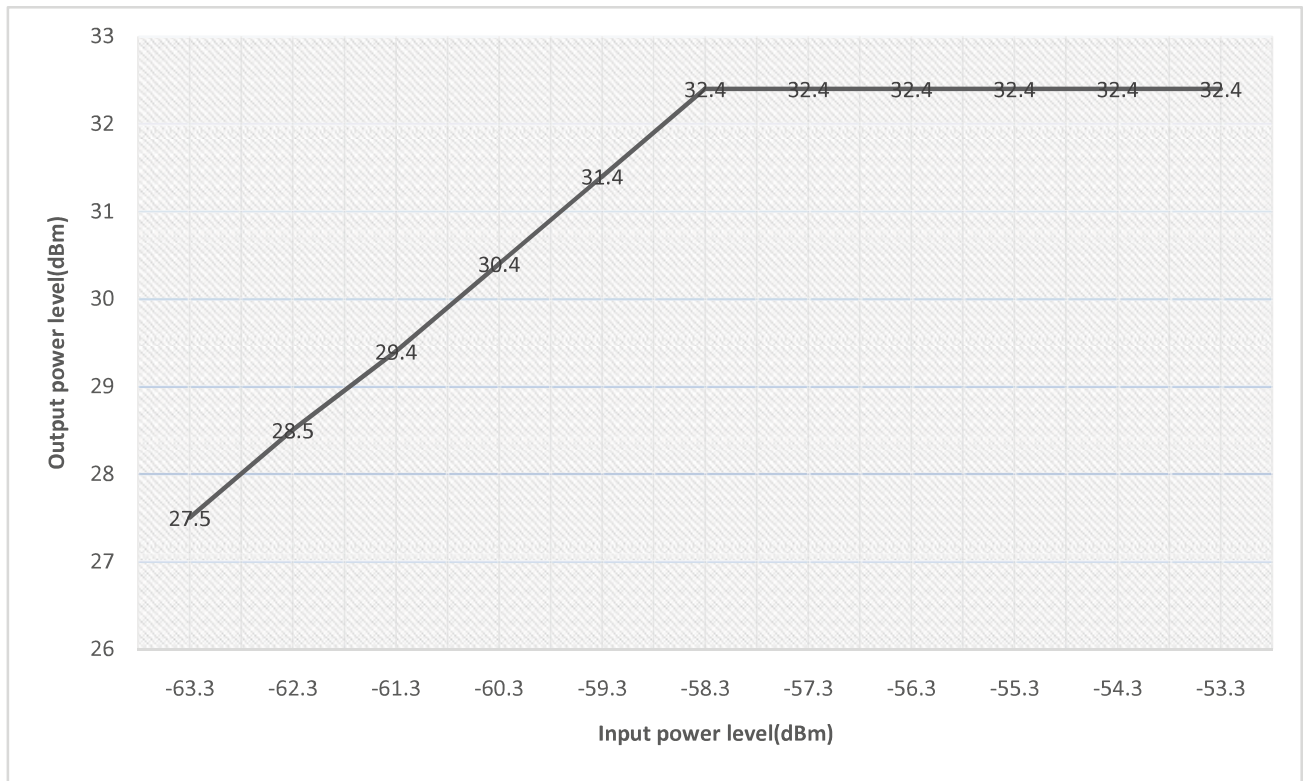

———— The following blanks ————

11.3.4.1.2. Uplink

11.3.4.1.2.1. P25 Phase I(C4FM)

816.00625MHz	-67.0	1.0	-68.0	22.2
	-66.0	1.0	-67.0	23.2
	-65.0	1.0	-66.0	24.2
	-64.0	1.0	-65.0	25.2
	-63.0	1.0	-64.0	26.2
	-62.0	1.0	-63.0	27.2
	-61.0	1.0	-62.0	27.2
	-60.0	1.0	-61.0	27.2
	-59.0	1.0	-60.0	27.2
	-58.0	1.0	-59.0	27.2
	-57.0	1.0	-58.0	27.2

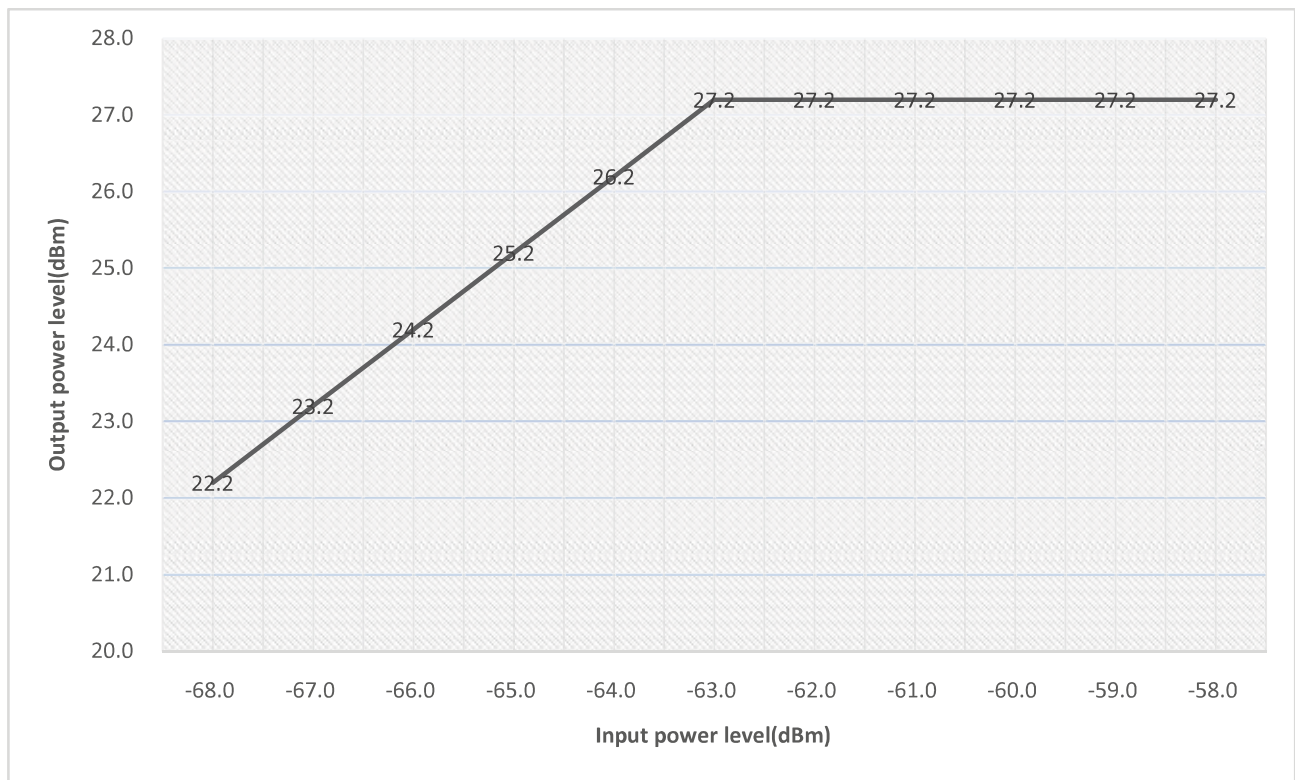

———— The following blanks ————

Test frequency	Signal output power (dBm)	EUT Input cable loss (dB)	EUT Corrected Input power (dBm)	EUT Corrected Output power (dBm)
816.99375MHz	-67.0	1.0	-68.0	22.2
	-66.0	1.0	-67.0	23.2
	-65.0	1.0	-66.0	24.2
	-64.0	1.0	-65.0	25.2
	-63.0	1.0	-64.0	26.2
	-62.0	1.0	-63.0	27.2
	-61.0	1.0	-62.0	27.2
	-60.0	1.0	-61.0	27.2
	-59.0	1.0	-60.0	27.2
	-58.0	1.0	-59.0	27.2
	-57.0	1.0	-58.0	27.2

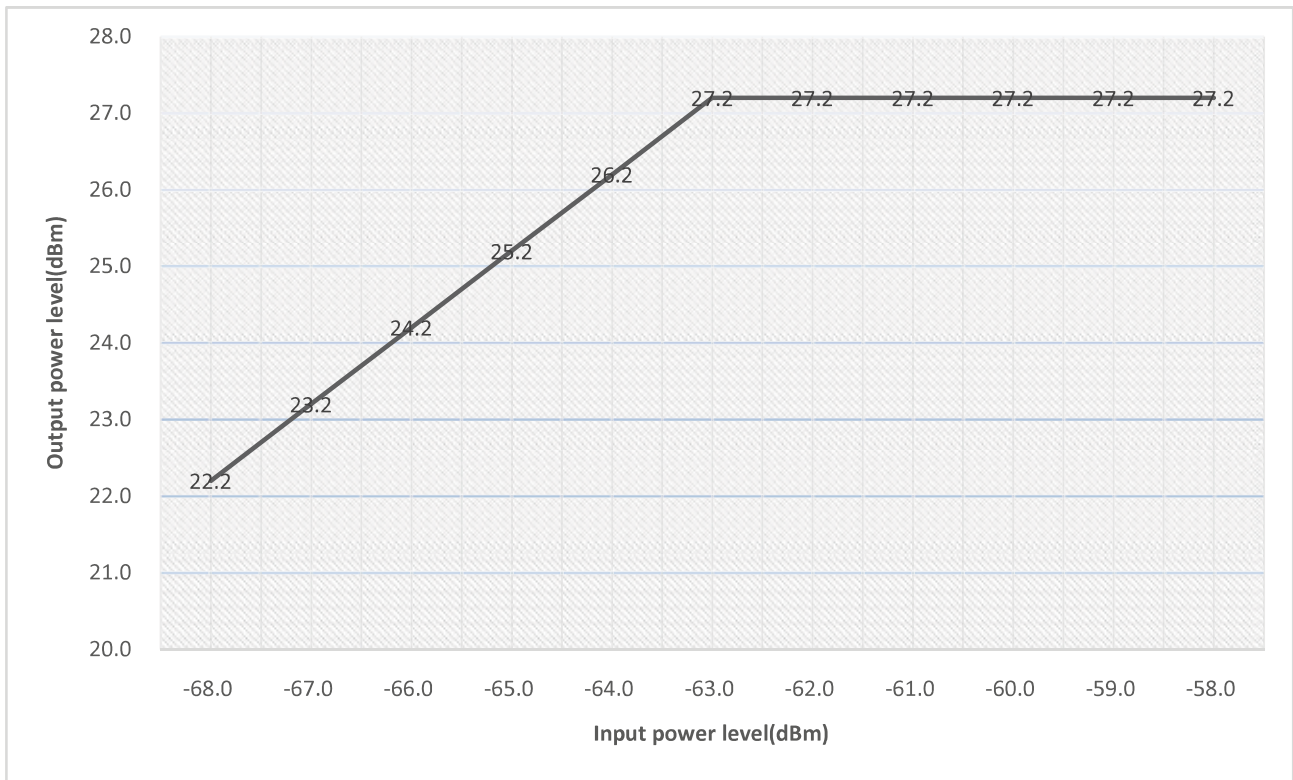

———— The following blanks ————

11.3.4.1.2.2. P25 Phase II(H-DQPSK)

816.00625MHz	-67.0	1.0	-68.0	22.2
	-66.0	1.0	-67.0	23.2
	-65.0	1.0	-66.0	24.2
	-64.0	1.0	-65.0	25.2
	-63.0	1.0	-64.0	26.2
	-62.0	1.0	-63.0	27.2
	-61.0	1.0	-62.0	27.2
	-60.0	1.0	-61.0	27.2
	-59.0	1.0	-60.0	27.2
	-58.0	1.0	-59.0	27.2
	-57.0	1.0	-58.0	27.2

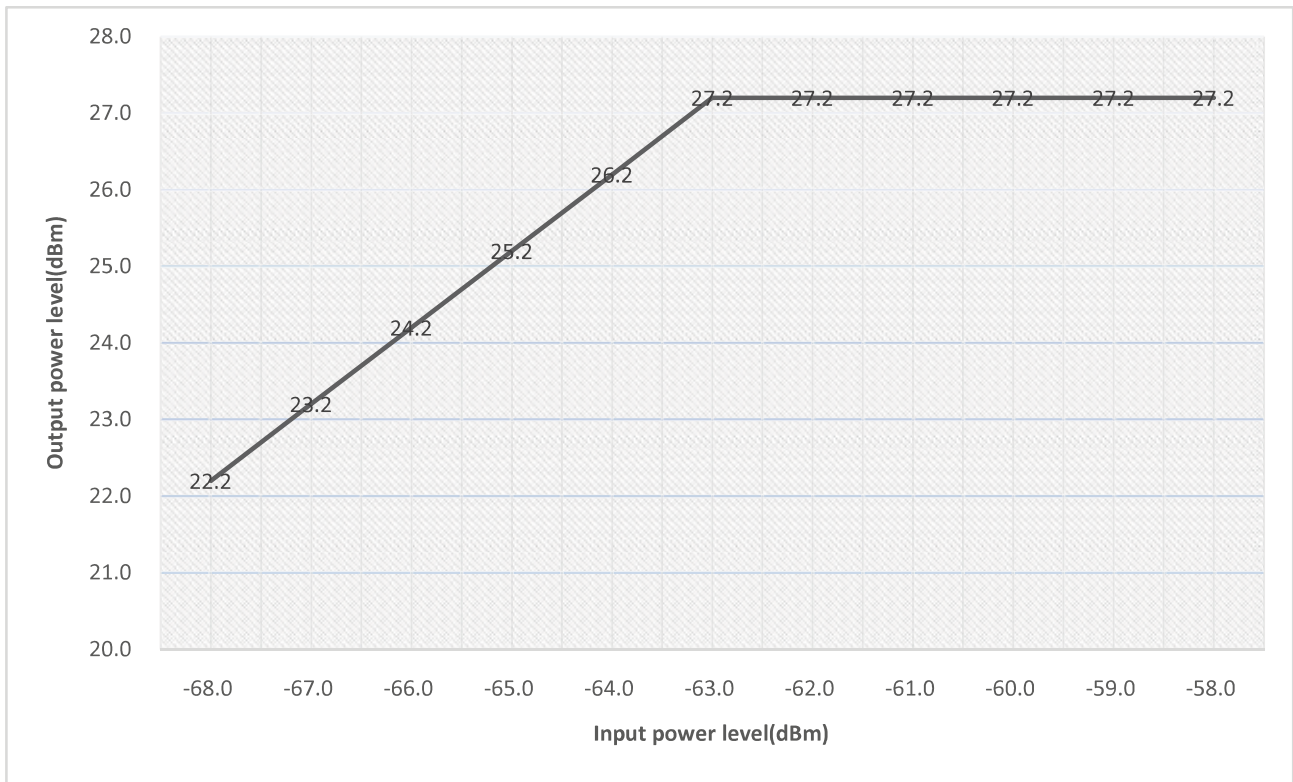

———— The following blanks ————

Test frequency	Signal output power (dBm)	EUT Input cable loss (dB)	EUT Corrected Input power (dBm)	EUT Corrected Output power (dBm)
816.99375MHz	-67.0	1.0	-68.0	22.2
	-66.0	1.0	-67.0	23.2
	-65.0	1.0	-66.0	24.2
	-64.0	1.0	-65.0	25.2
	-63.0	1.0	-64.0	26.2
	-62.0	1.0	-63.0	27.2
	-61.0	1.0	-62.0	27.2
	-60.0	1.0	-61.0	27.2
	-59.0	1.0	-60.0	27.2
	-58.0	1.0	-59.0	27.2
	-57.0	1.0	-58.0	27.2

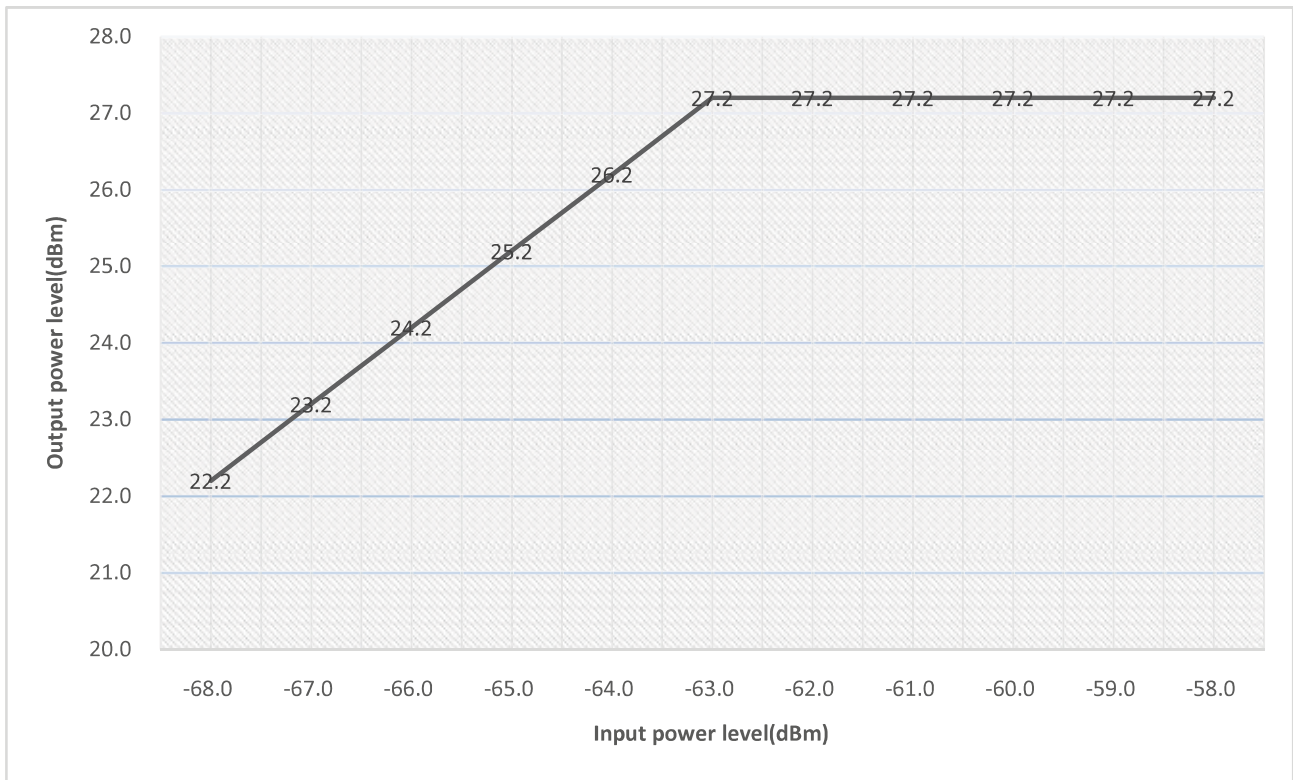

———— The following blanks ————

11.3.4.1.2.3. DMR

816.00625MHz	-67.0	1.0	-68.0	22.2
	-66.0	1.0	-67.0	23.2
	-65.0	1.0	-66.0	24.2
	-64.0	1.0	-65.0	25.2
	-63.0	1.0	-64.0	26.2
	-62.0	1.0	-63.0	27.2
	-61.0	1.0	-62.0	27.2
	-60.0	1.0	-61.0	27.2
	-59.0	1.0	-60.0	27.2
	-58.0	1.0	-59.0	27.2
	-57.0	1.0	-58.0	27.2

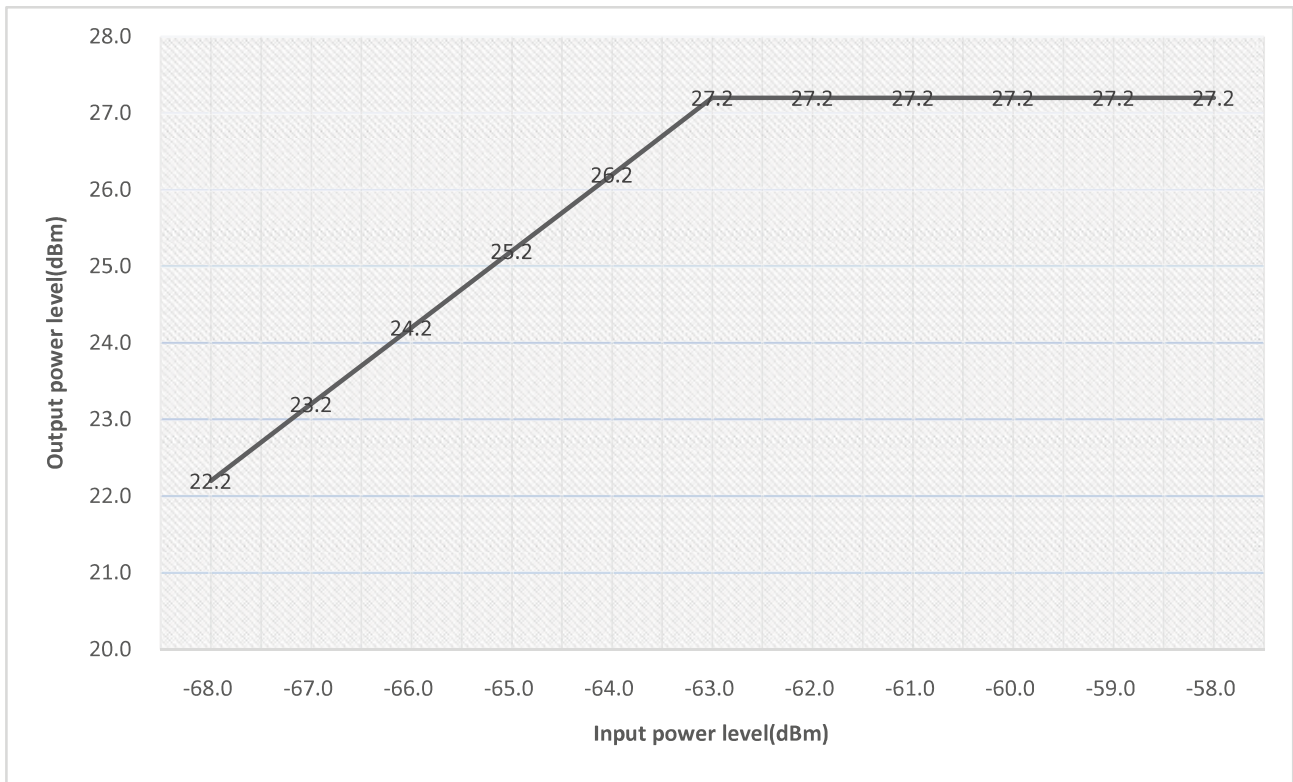

———— The following blanks ————

Test frequency	Signal output power (dBm)	EUT Input cable loss (dB)	EUT Corrected Input power (dBm)	EUT Corrected Output power (dBm)
816.99375MHz	-67.0	1.0	-68.0	22.2
	-66.0	1.0	-67.0	23.2
	-65.0	1.0	-66.0	24.2
	-64.0	1.0	-65.0	25.2
	-63.0	1.0	-64.0	26.2
	-62.0	1.0	-63.0	27.2
	-61.0	1.0	-62.0	27.2
	-60.0	1.0	-61.0	27.2
	-59.0	1.0	-60.0	27.2
	-58.0	1.0	-59.0	27.2
	-57.0	1.0	-58.0	27.2

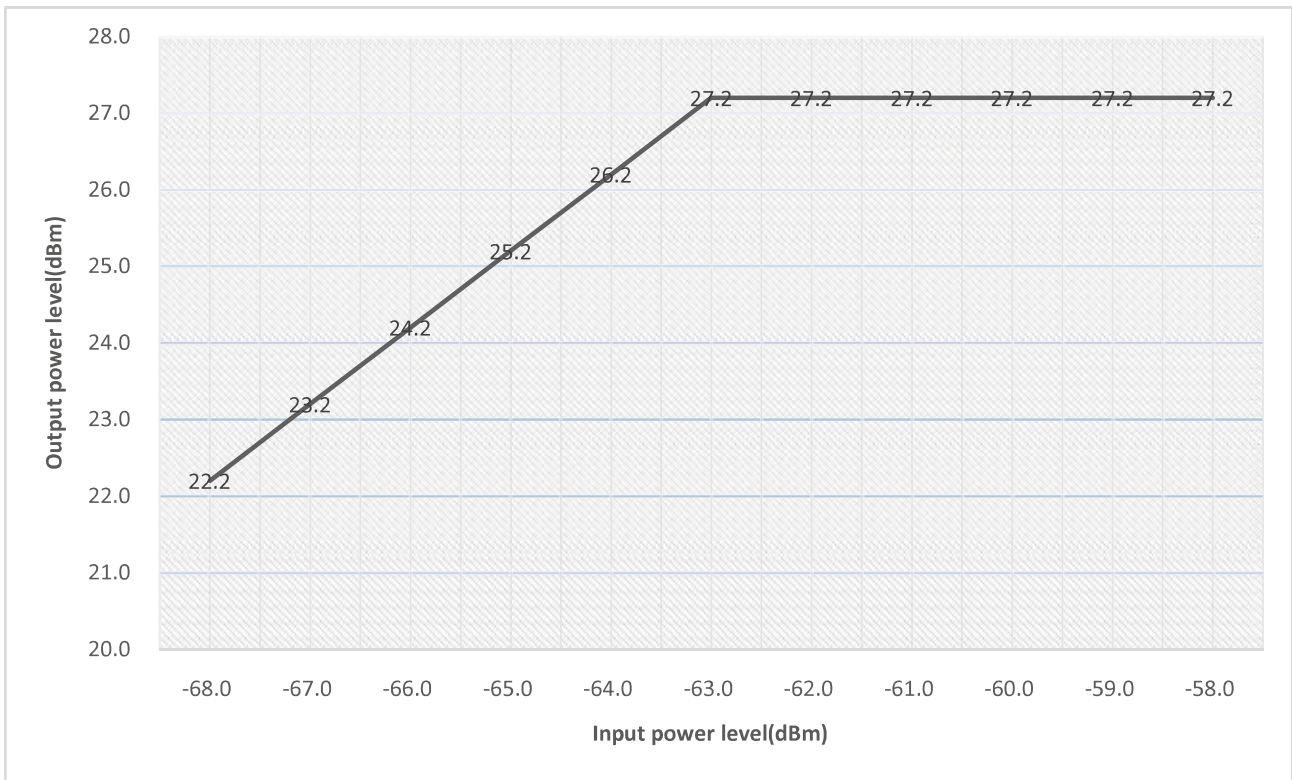

———— The following blanks ————

11.3.4.1.2.4. Analog FM

816.0125MHz	-67.0	1.0	-68.0	22.2
	-66.0	1.0	-67.0	23.2
	-65.0	1.0	-66.0	24.2
	-64.0	1.0	-65.0	25.2
	-63.0	1.0	-64.0	26.2
	-62.0	1.0	-63.0	27.1
	-61.0	1.0	-62.0	27.1
	-60.0	1.0	-61.0	27.1
	-59.0	1.0	-60.0	27.1
	-58.0	1.0	-59.0	27.1
	-57.0	1.0	-58.0	27.1

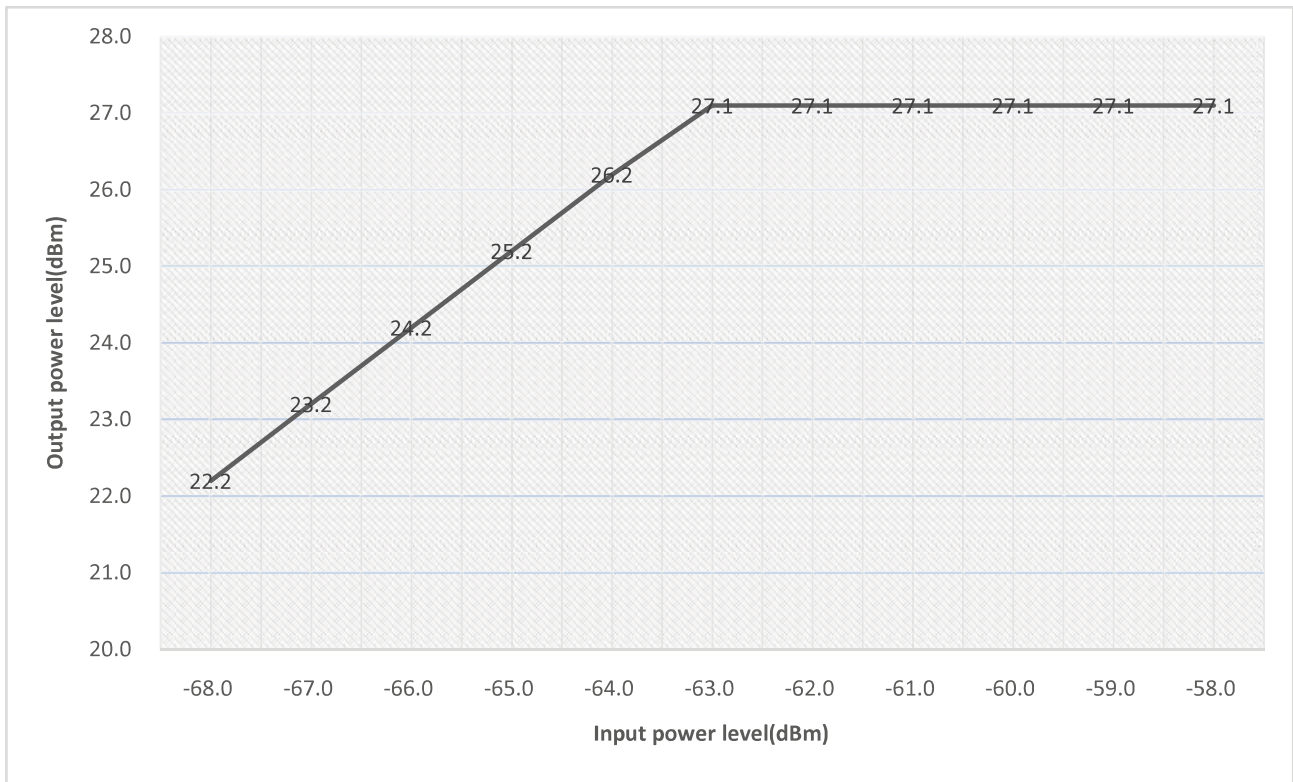

———— The following blanks ————

Test frequency	Signal output power (dBm)	EUT Input cable loss (dB)	EUT Corrected Input power (dBm)	EUT Corrected Output power (dBm)
816.9875MHz	-67.0	1.0	-68.0	22.2
	-66.0	1.0	-67.0	23.2
	-65.0	1.0	-66.0	24.2
	-64.0	1.0	-65.0	25.2
	-63.0	1.0	-64.0	26.2
	-62.0	1.0	-63.0	27.1
	-61.0	1.0	-62.0	27.1
	-60.0	1.0	-61.0	27.1
	-59.0	1.0	-60.0	27.1
	-58.0	1.0	-59.0	27.1
	-57.0	1.0	-58.0	27.1

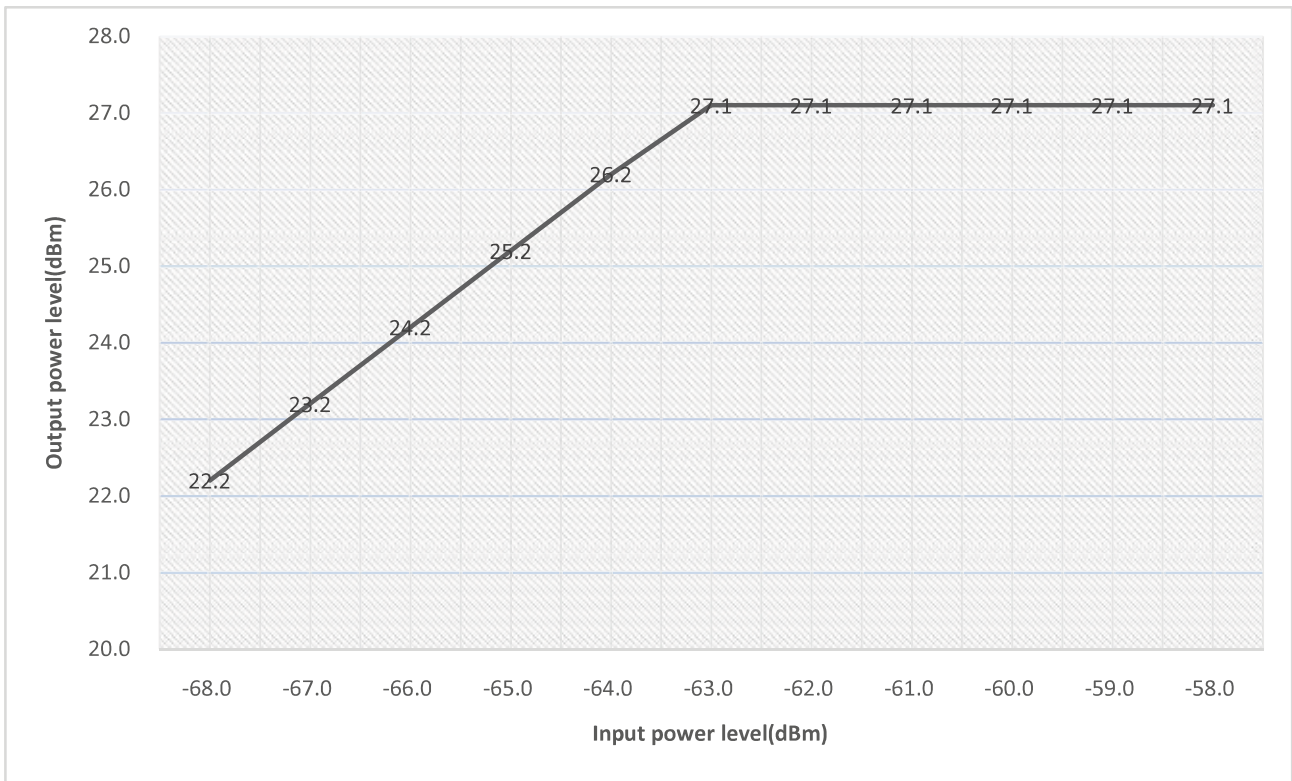

———— The following blanks ————

11.3.4.1.2.5. Tetra

816.0125MHz	-67.0	1.0	-68.0	22.2
	-66.0	1.0	-67.0	23.2
	-65.0	1.0	-66.0	24.2
	-64.0	1.0	-65.0	25.2
	-63.0	1.0	-64.0	26.2
	-62.0	1.0	-63.0	27.2
	-61.0	1.0	-62.0	27.2
	-60.0	1.0	-61.0	27.2
	-59.0	1.0	-60.0	27.2
	-58.0	1.0	-59.0	27.2
	-57.0	1.0	-58.0	27.2

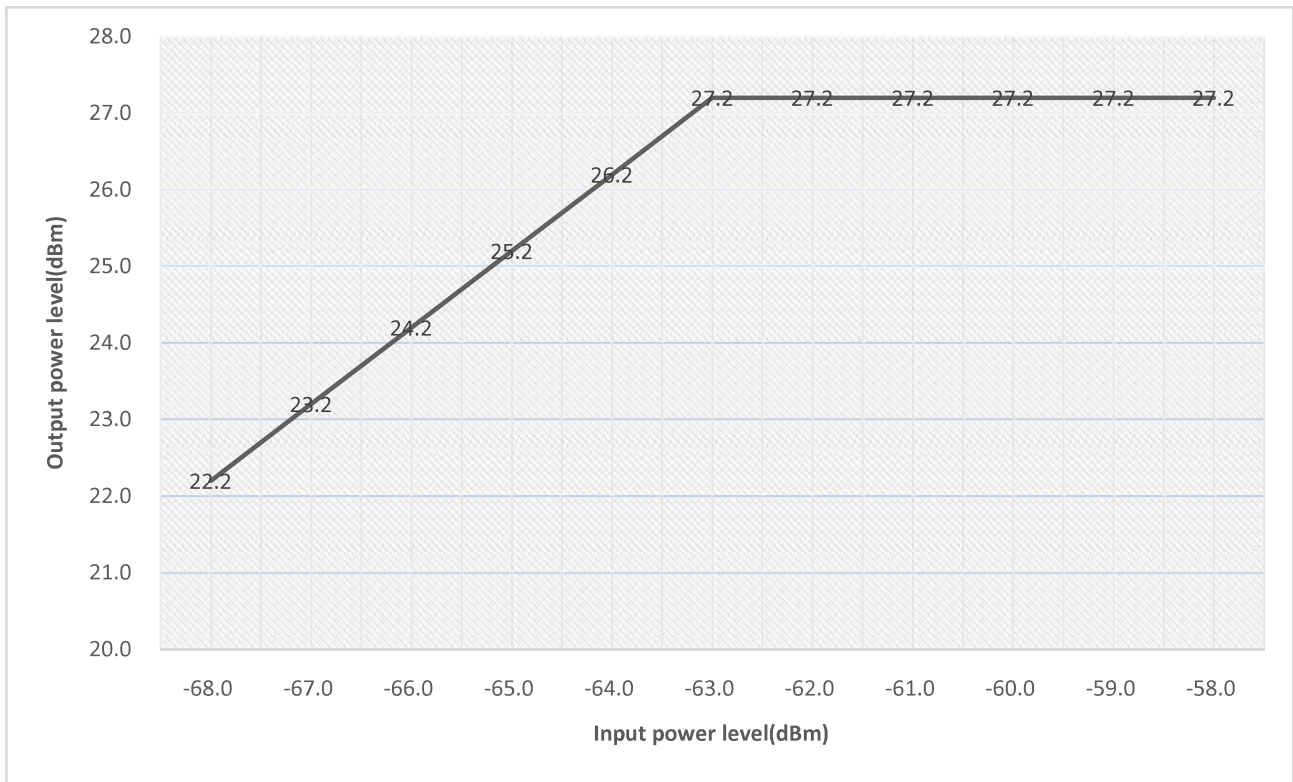

———— The following blanks ————

Test frequency	Signal output power (dBm)	EUT Input cable loss (dB)	EUT Corrected Input power (dBm)	EUT Corrected Output power (dBm)
816.9875MHz	-67.0	1.0	-68.0	22.2
	-66.0	1.0	-67.0	23.2
	-65.0	1.0	-66.0	24.2
	-64.0	1.0	-65.0	25.2
	-63.0	1.0	-64.0	26.2
	-62.0	1.0	-63.0	27.2
	-61.0	1.0	-62.0	27.2
	-60.0	1.0	-61.0	27.2
	-59.0	1.0	-60.0	27.2
	-58.0	1.0	-59.0	27.2
	-57.0	1.0	-58.0	27.2

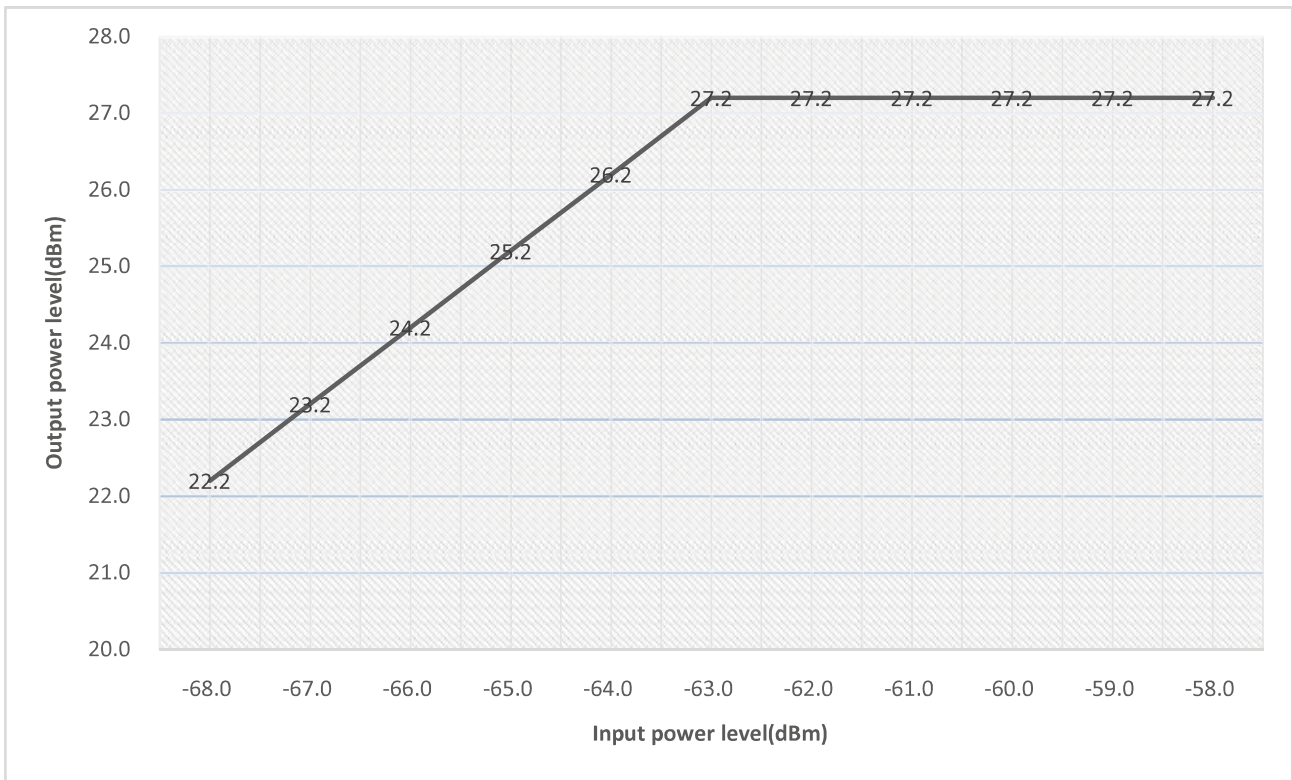

———— The following blanks ————

11.4. Out-of-band rejection

Test requirement: FCC PART 90.219 (a)
FCC PART 90.219 (d)((7))

Test Method: KDB 935210 D05 clause 4.3

11.4.1. Requirements

According to KDB 935210 D05 clause 4.3 requirement, A signal booster shall reject amplification of other signals outside of its pass band. Adjust the internal gain control of the EUT to the maximum gain for which equipment certification is sought.

11.4.2. Test configuration

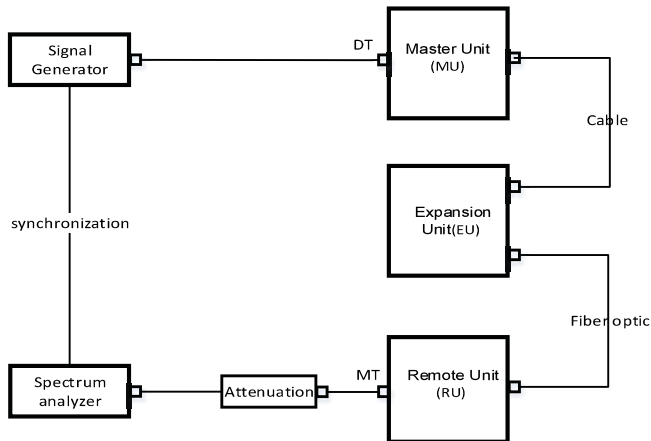

Figure 11.4-1 Downlink connection diagram

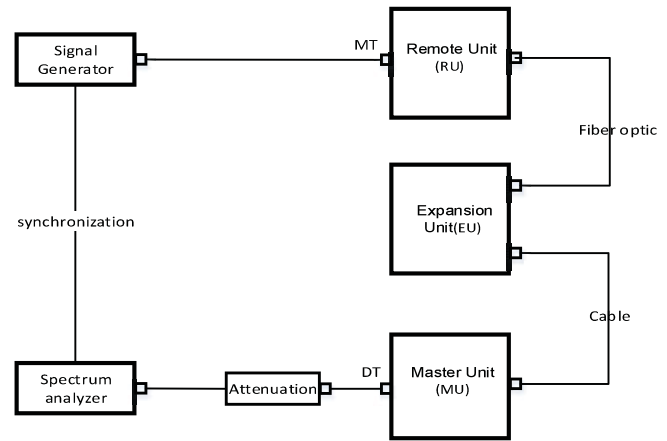

Figure 11.4-2 Uplink connection diagram

11.4.3. Test procedures

- a) Connect a signal generator to the input of the EUT.
- b) Configure a swept CW signal with the following parameters:
 - 1) Frequency range = $\pm 250\%$ of the manufacturer's specified pass band.
 - 2) The CW amplitude shall be 3 dB below the AGC threshold (see 4.2), and shall not activate the AGC threshold throughout the test.
 - 3) Dwell time = approximately 10 ms.
 - 4) Frequency step = 50 kHz.
- c) Connect a spectrum analyzer to the output of the EUT using appropriate attenuation.
- d) Set the RBW of the spectrum analyzer to between 1 % and 5 % of the manufacturer's rated passband, and $VBW = 3 \times RBW$.
- e) Set the detector to Peak and the trace to Max-Hold.
- f) After the trace is completely filled, place a marker at the peak amplitude, which is designated as f_0 , and with two additional markers (use the marker-delta method) at the 20 dB bandwidth (i.e., at the points where the level has fallen by 20 dB).
- g) Capture the frequency response plot for inclusion in the test report.

11.4.4. Test results

Test Date (yy-mm-dd): 2024-05-15

Normal condition: Temp:26.2°C, Humid: 43%, Atmospheric Pressure:101kpa

Supply Voltage: AC 110V, 50Hz

11.4.4.1. 800MHz Band (Downlink: 861MHz ~862MHz, Uplink: 816MHz ~ 817MHz)

RBW (kHz)	VBW (kHz)	20dB Down		20dB BW (MHz)
		Below frequency (MHz)	Up frequency (MHz)	
(1) Downlink: 861MHz~862MHz				
30	100	860.6404	862.3640	1.7236
(2) Uplink: 816MHz~817MHz				
30	100	815.6317	817.3683	1.7366

----- The following blanks -----