

Date: 18.MAY.2023 09:41:50

Middle Frequency: 802.0MHz, Output occupied BW(AGC)

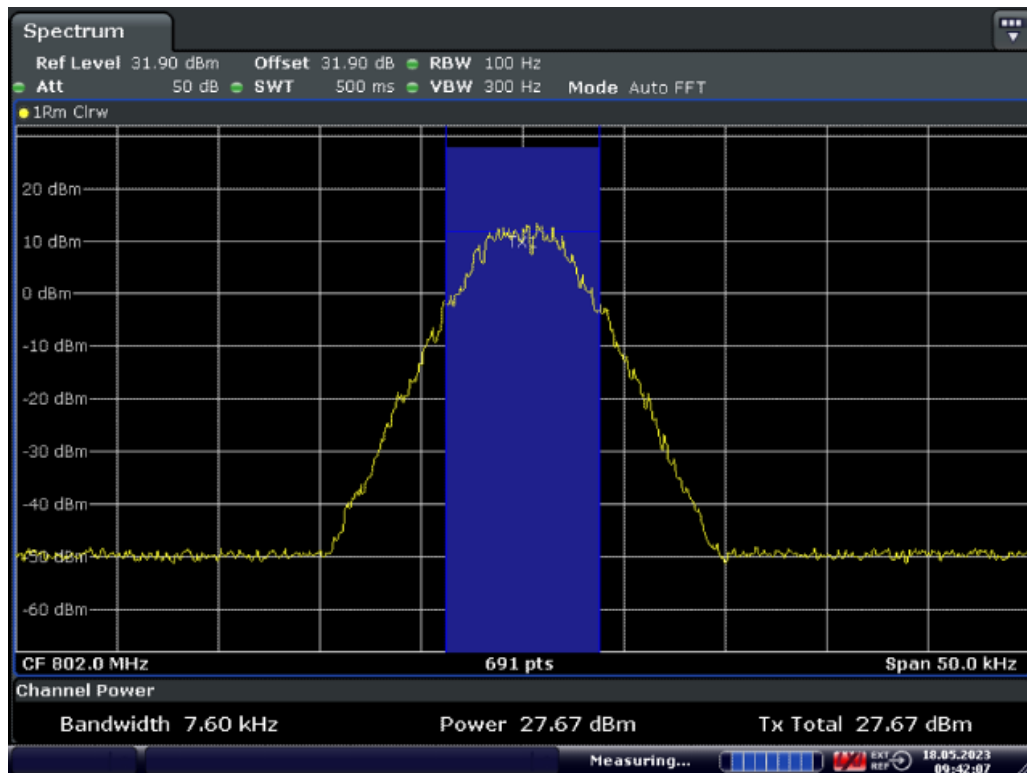

Date: 18.MAY.2023 09:42:07

Middle Frequency: 802.0MHz, Output occupied BW (with the input signal amplitude set 3 dB above the AGC threshold)

11.5.5.3.1.4. Analog FM

11.5.5.3.1.4.1. Downlink

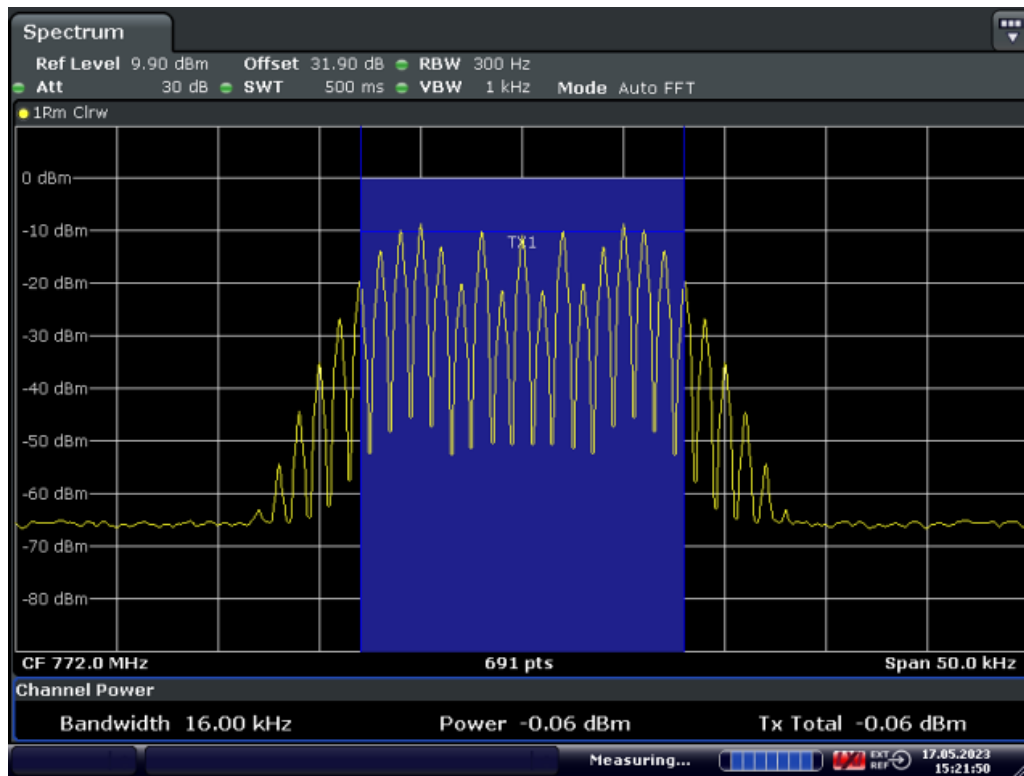

Date: 17.MAY.2023 15:21:51

Middle Frequency: 772.0MHz, Input occupied BW

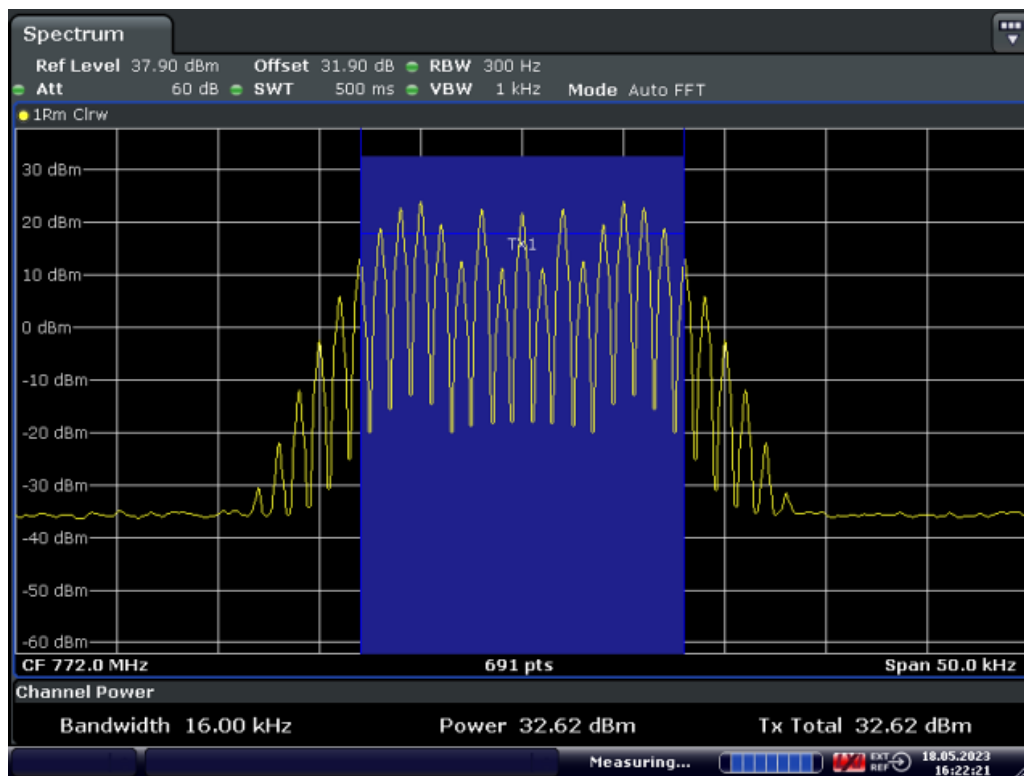

Date: 18.MAY.2023 16:22:22

Middle Frequency: 772.0MHz, Output occupied BW(AGC)

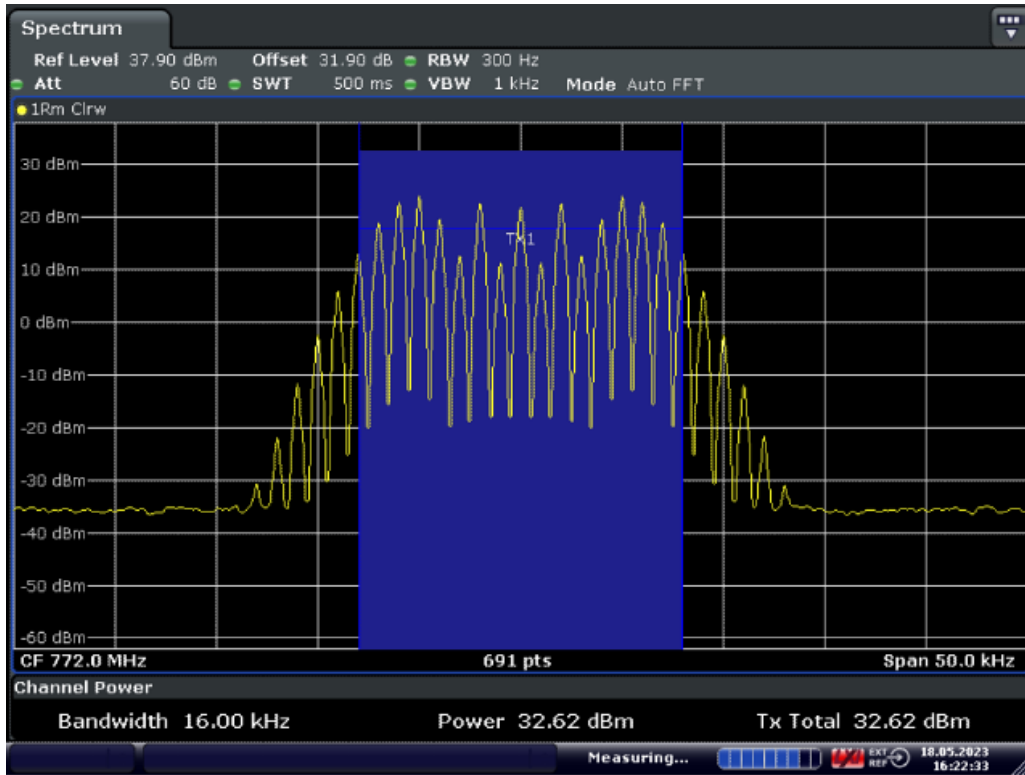

Date: 18.MAY.2023 16:22:34

Middle Frequency: 772.0MHz, Output occupied BW (with the input signal amplitude set 3 dB above the AGC threshold)

11.5.5.3.1.4.2. Uplink

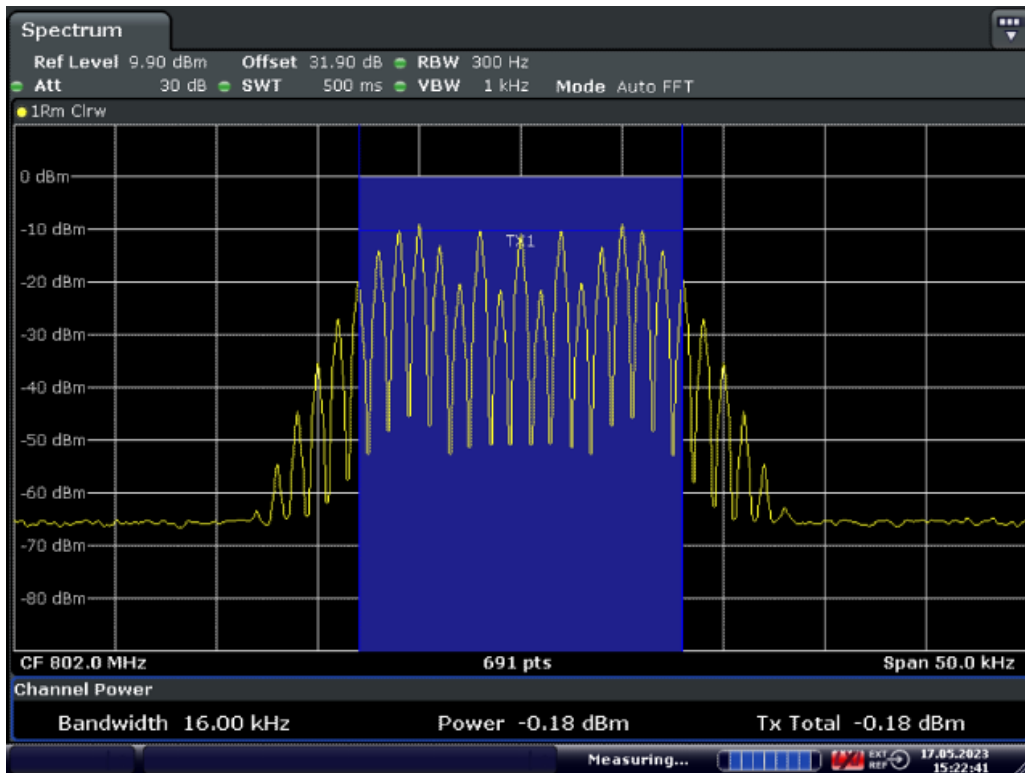

Date: 17.MAY.2023 15:22:41

Middle Frequency: 802.0MHz MHz, Input occupied BW

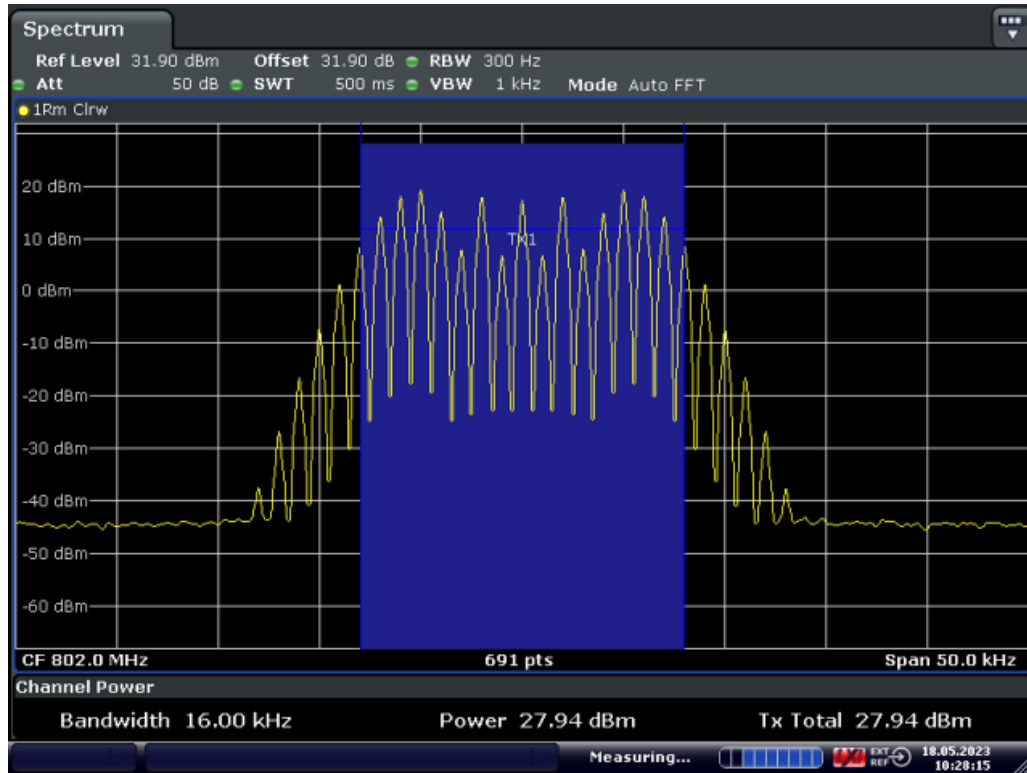

Date: 18.MAY.2023 10:28:15

Middle Frequency: 802.0MHz, Output occupied BW(AGC)

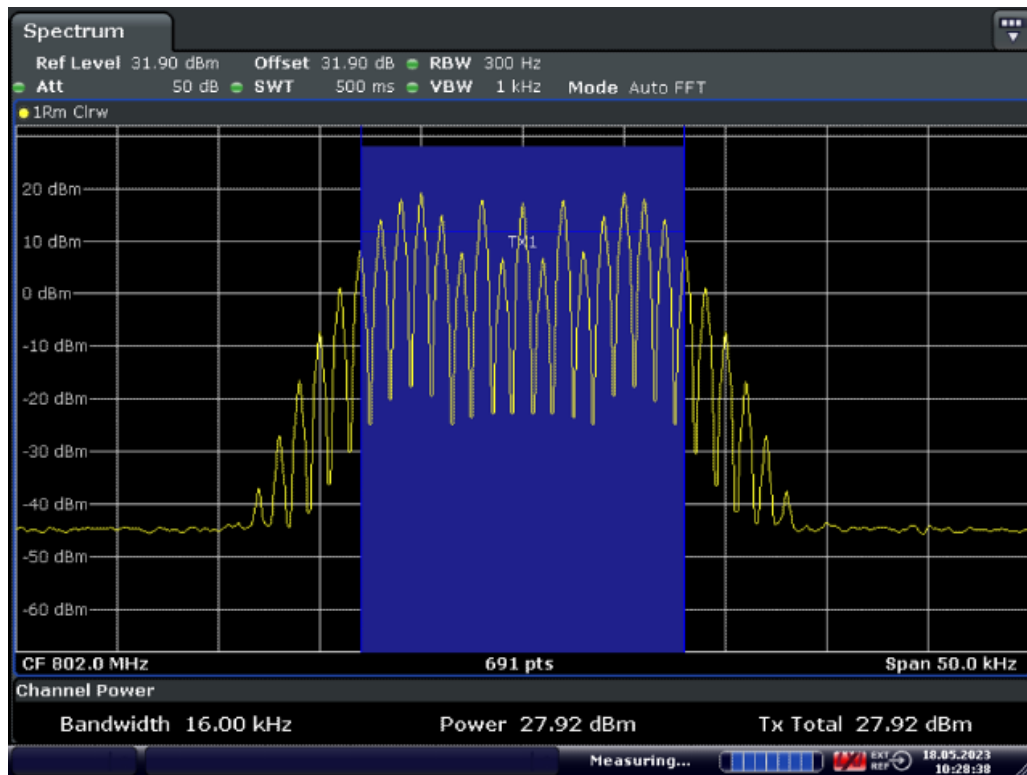

Date: 18.MAY.2023 10:28:38

Middle Frequency: 802.0MHz, Output occupied BW (with the input signal amplitude set 3 dB above the AGC threshold)

11.5.5.3.1.5. Tetra

11.5.5.3.1.5.1. Downlink

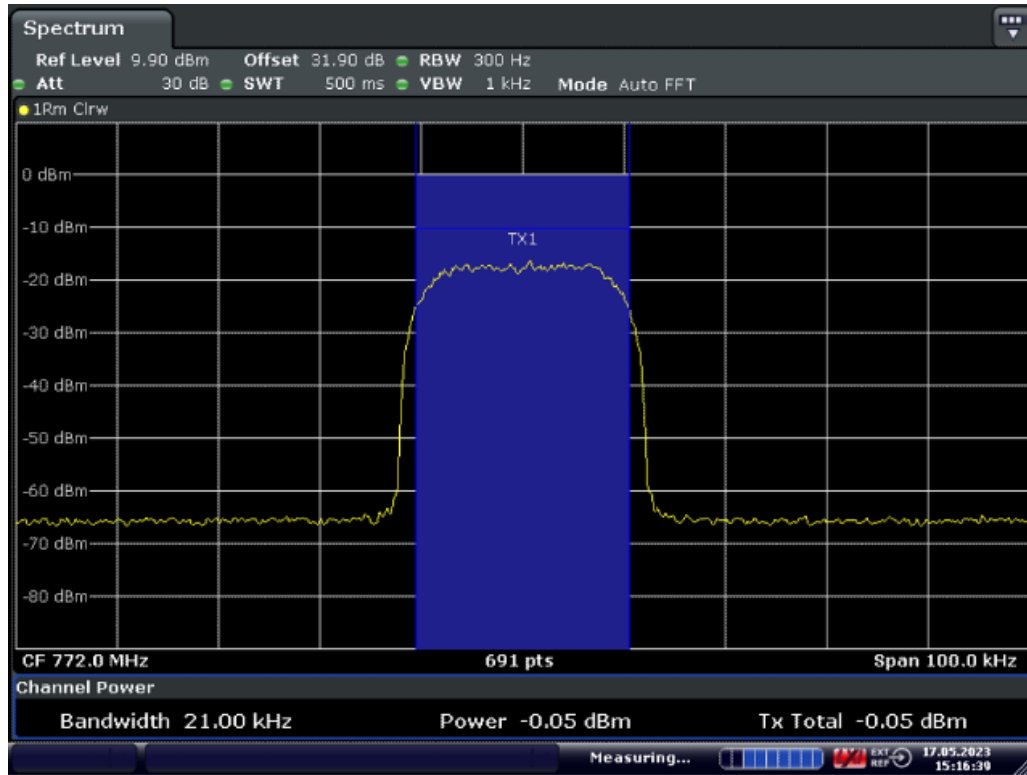

Date: 17.MAY.2023 15:16:39

Middle Frequency: 772.0MHz, Input occupied BW

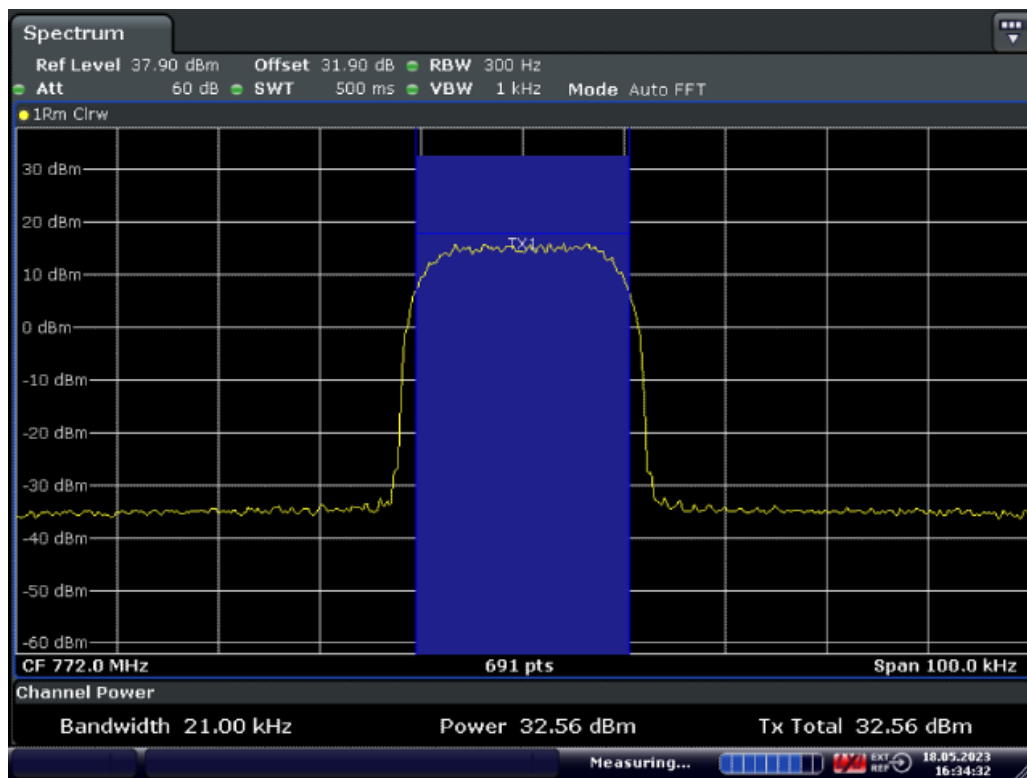

Date: 18.MAY.2023 16:34:32

Middle Frequency: 772.0MHz, Output occupied BW(AGC)

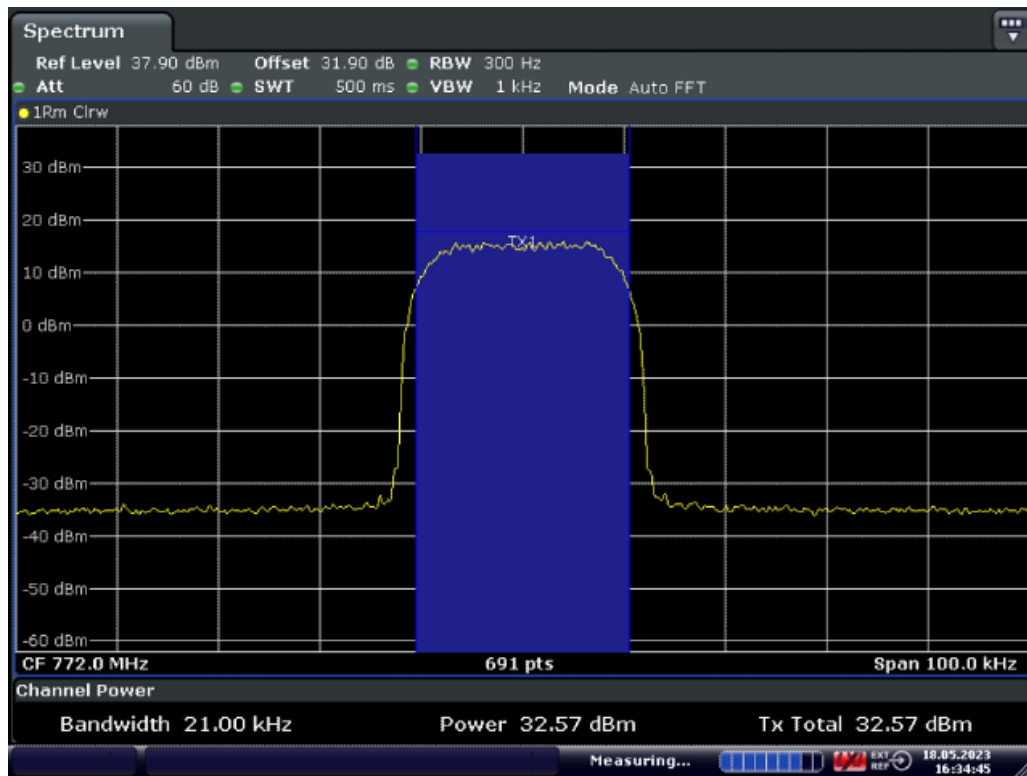

Date: 18.MAY.2023 16:34:45

Middle Frequency: 772.0MHz, Output occupied BW (with the input signal amplitude set 3 dB above the AGC threshold)

11.5.5.3.1.5.2. Uplink

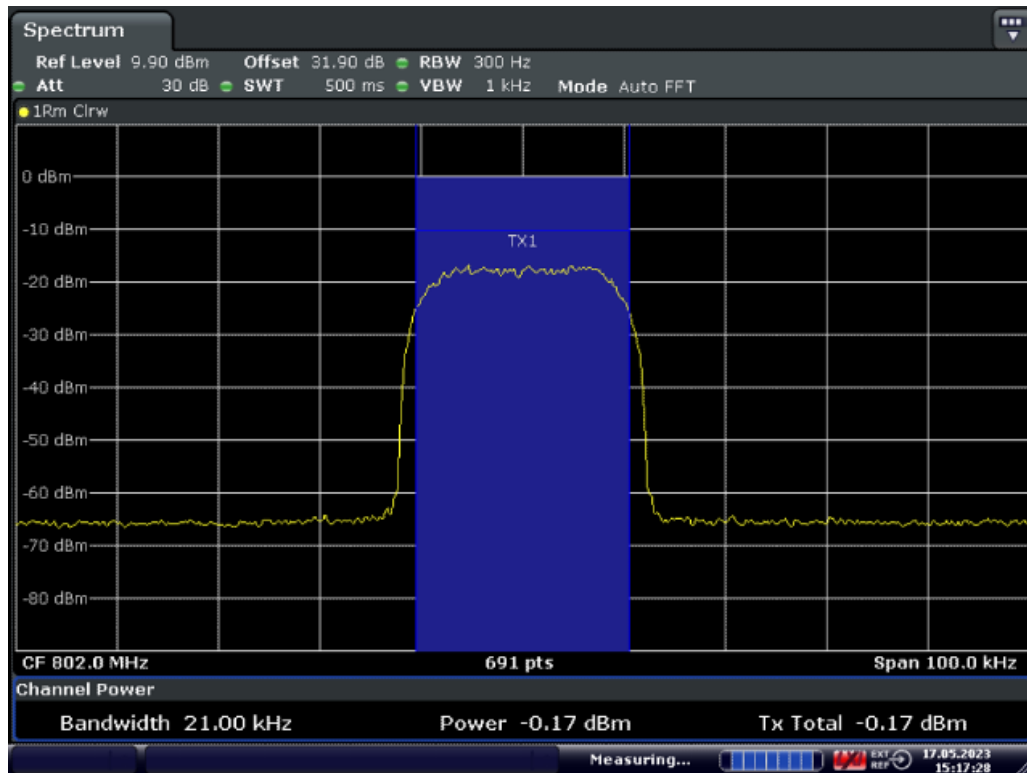

Date: 17.MAY.2023 15:17:29

Middle Frequency: 802.0MHz MHz, Input occupied BW

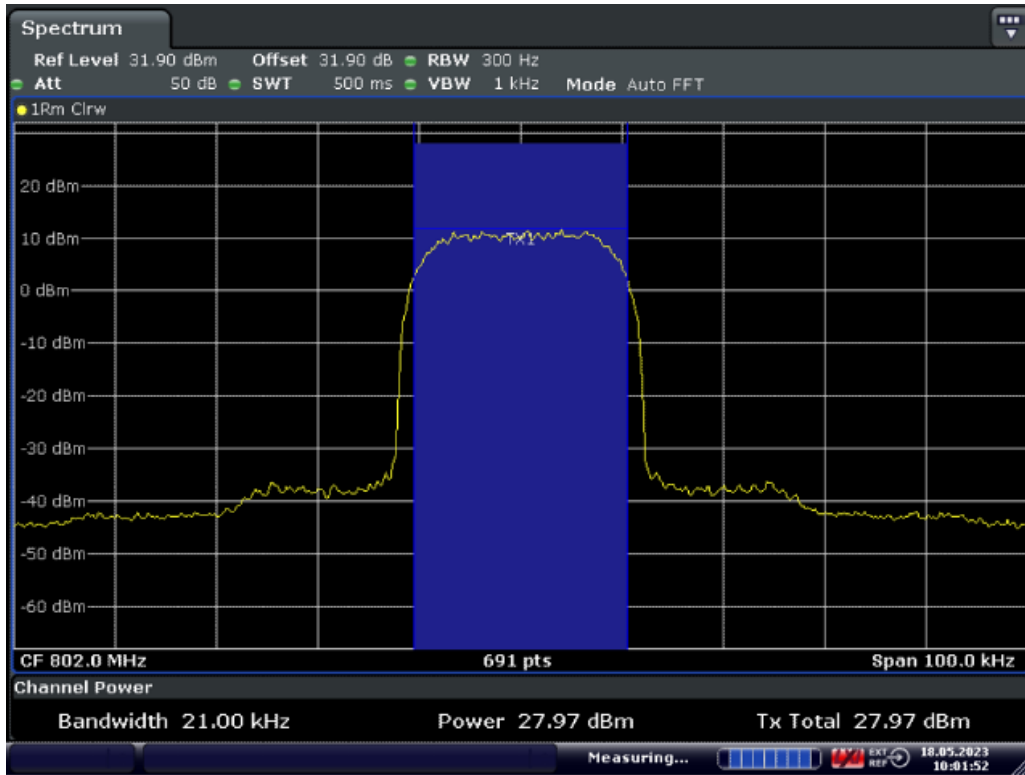

Date: 18.MAY.2023 10:01:52

Middle Frequency: 802.0MHz, Output occupied BW(AGC)

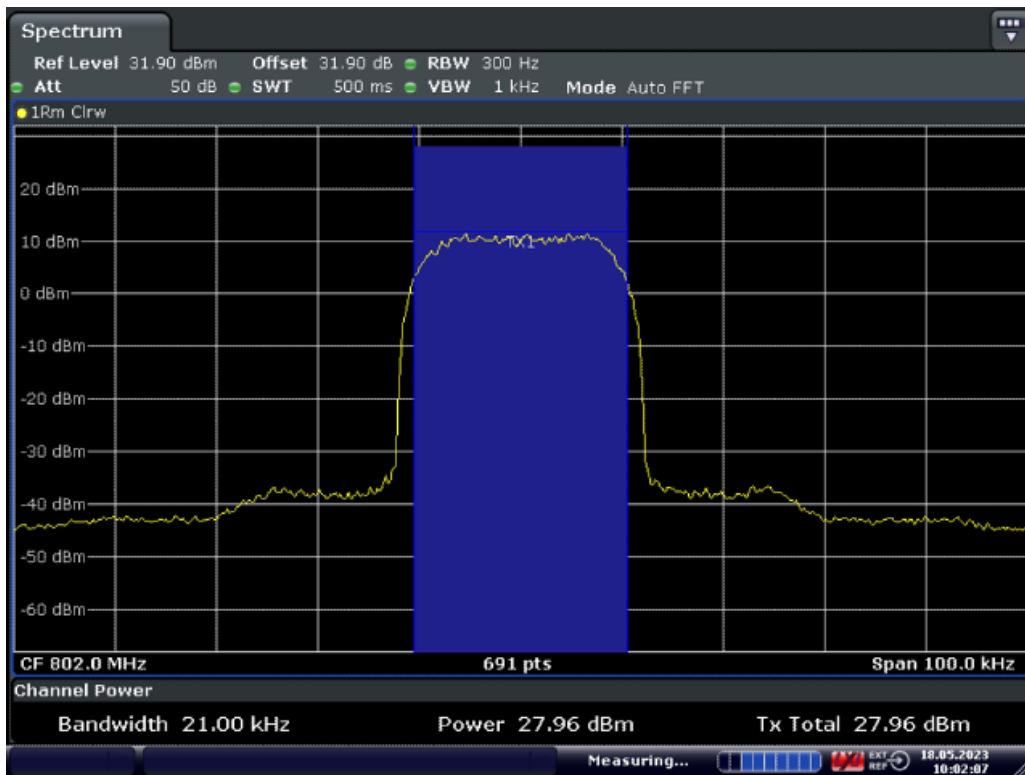

Date: 18.MAY.2023 10:02:08

Middle Frequency: 802.0MHz, Output occupied BW (with the input signal amplitude set 3 dB above the AGC threshold)

11.5.5.3.2. 800MHz Band

11.5.5.3.2.1. P25 Phase I(C4FM)

11.5.5.3.2.1.1. Downlink

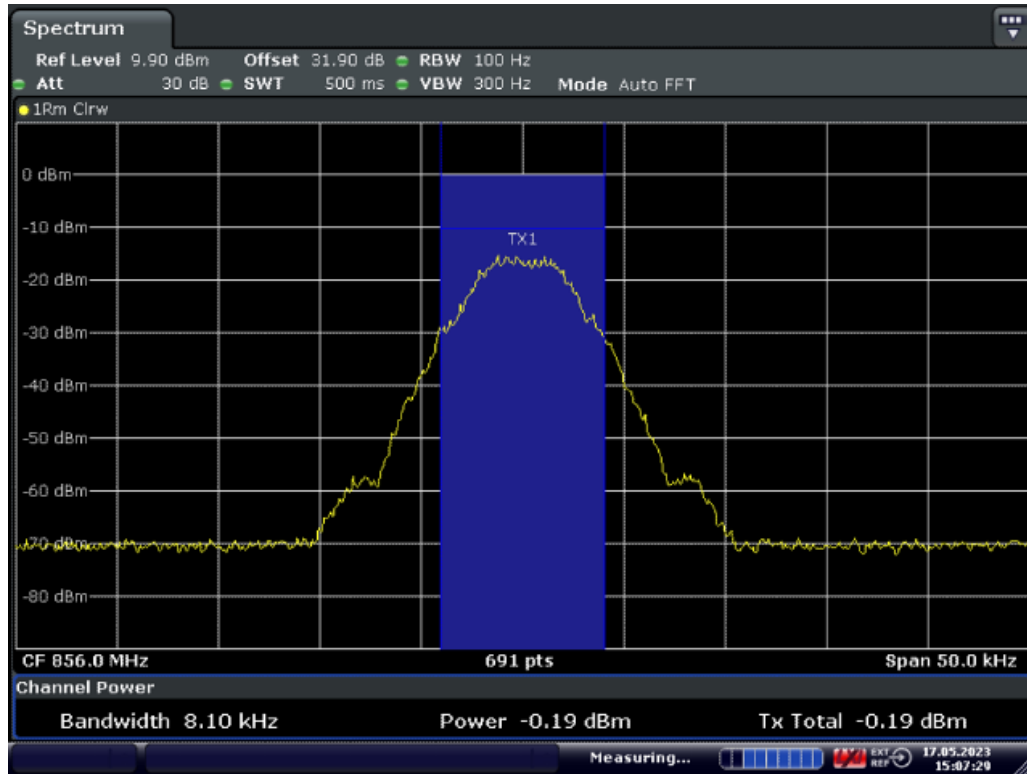

Date: 17.MAY.2023 15:07:29

Middle Frequency: 856.0MHz, Input occupied BW

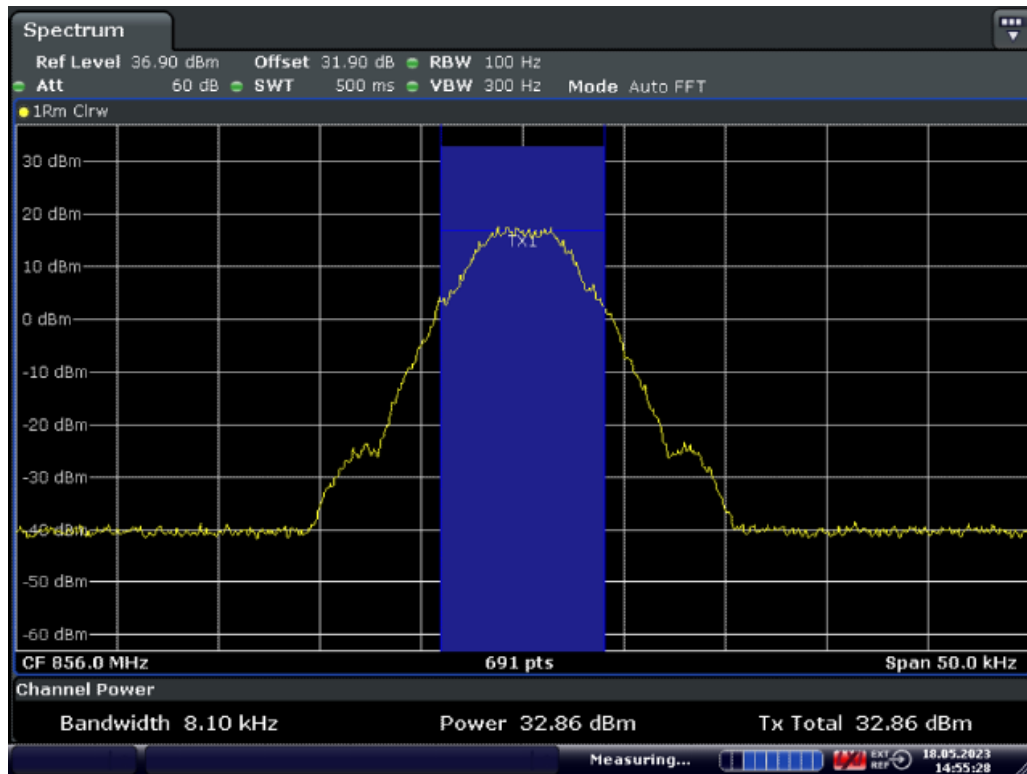

Date: 18.MAY.2023 14:55:29

Middle Frequency: 856.0MHz, Output occupied BW(AGC)

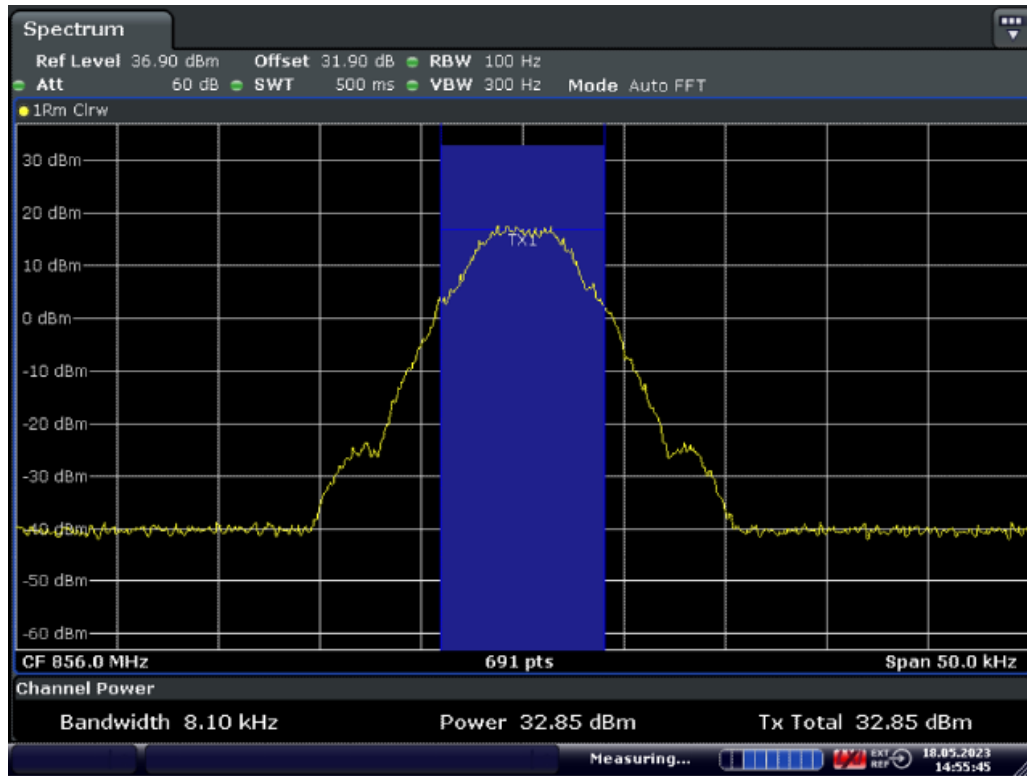

Date: 18.MAY.2023 14:55:45

Middle Frequency: 856.0MHz, Output occupied BW (with the input signal amplitude set 3 dB above the AGC threshold)

11.5.5.3.2.1.2. Uplink

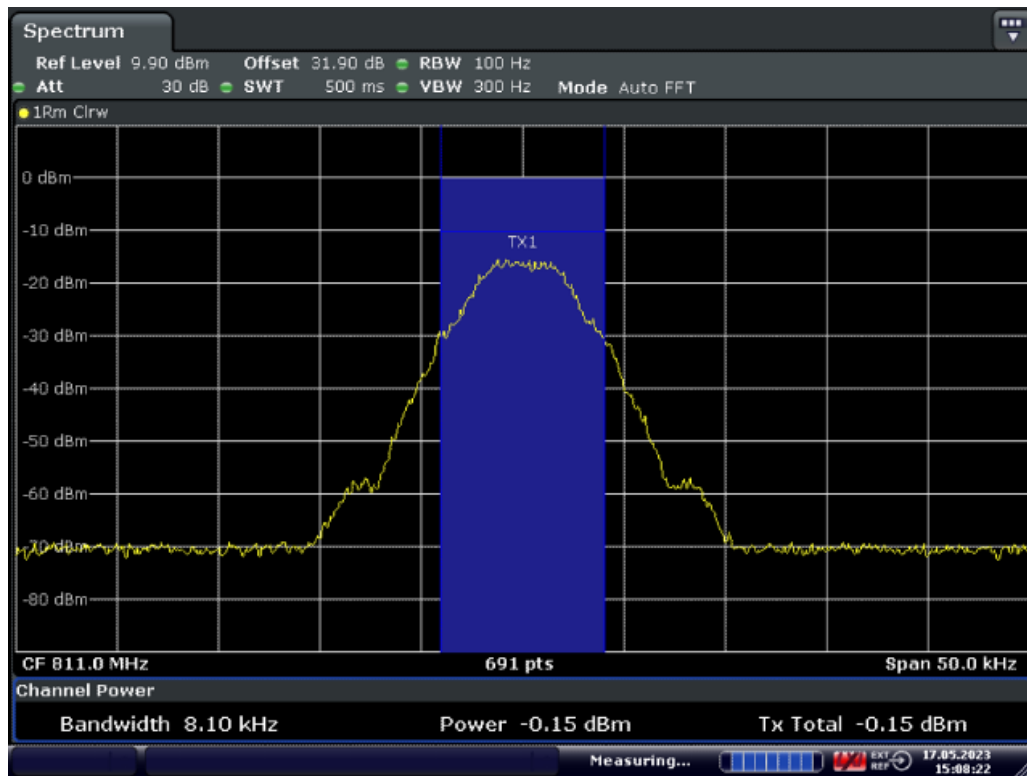

Date: 17.MAY.2023 15:08:22

Middle Frequency: 811.0MHz MHz, Input occupied BW

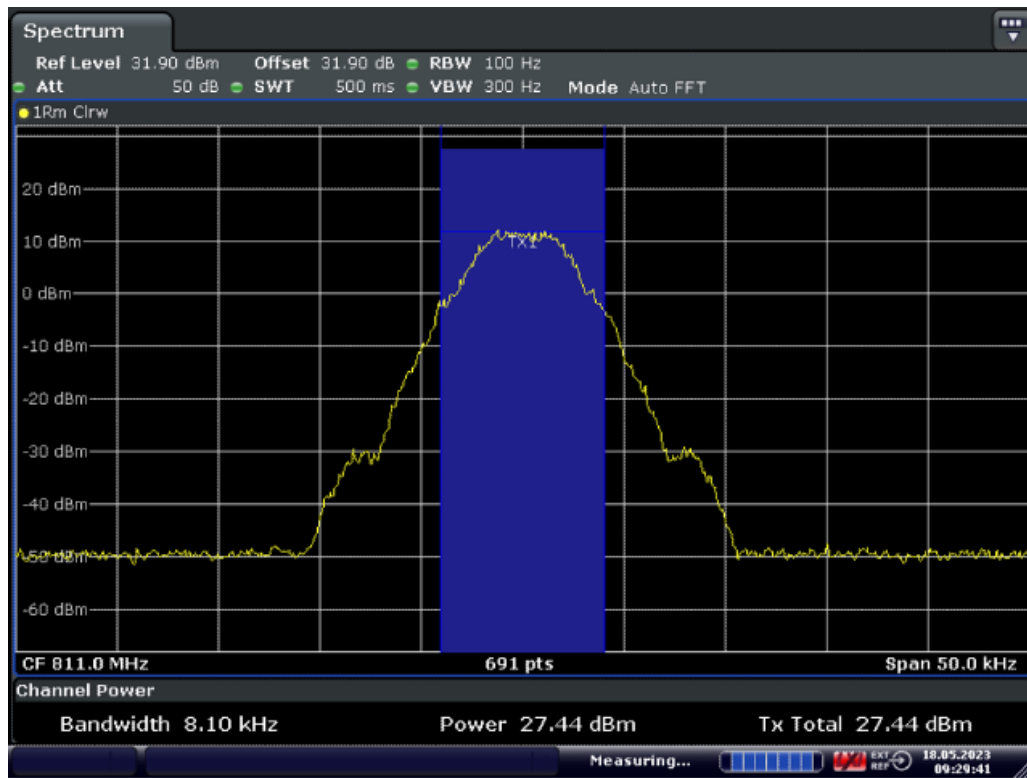

Date: 18.MAY.2023 09:29:42

Middle Frequency: 811.0MHz, Output occupied BW(AGC)

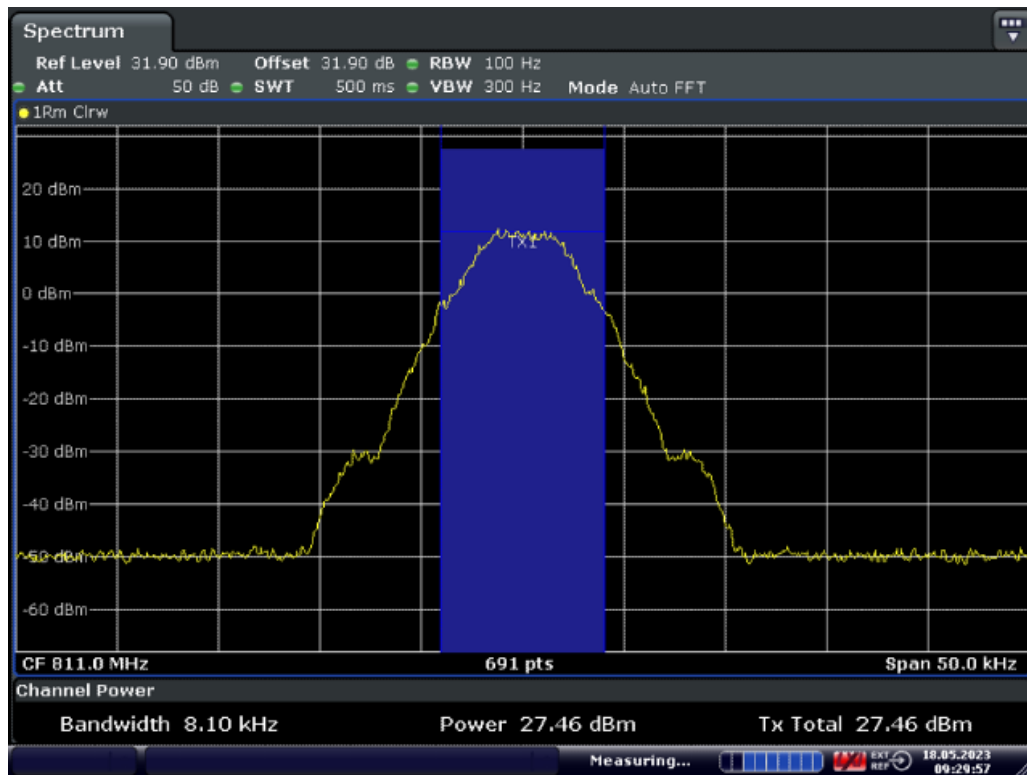

Date: 18.MAY.2023 09:29:57

Middle Frequency: 811.0MHz, Output occupied BW (with the input signal amplitude set 3 dB above the AGC threshold)

11.5.5.3.2.2. P25 Phase II(H-DQPSK)

11.5.5.3.2.2.1. Downlink

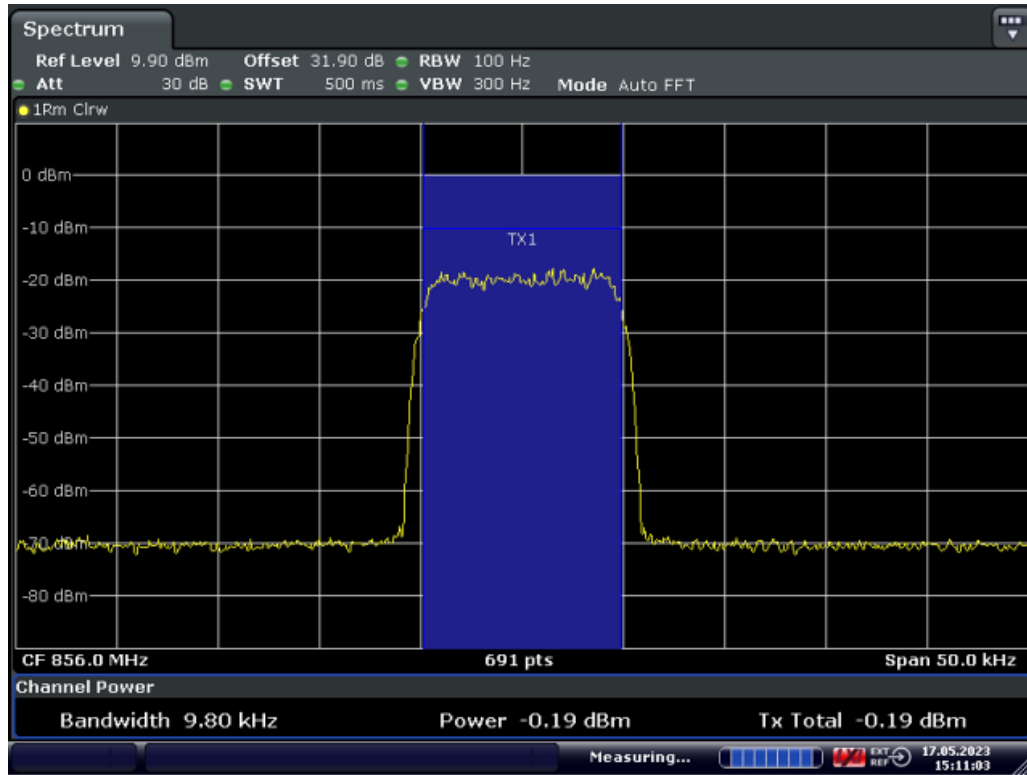

Date: 17.MAY.2023 15:11:03

Middle Frequency: 856.0MHz, Input occupied BW

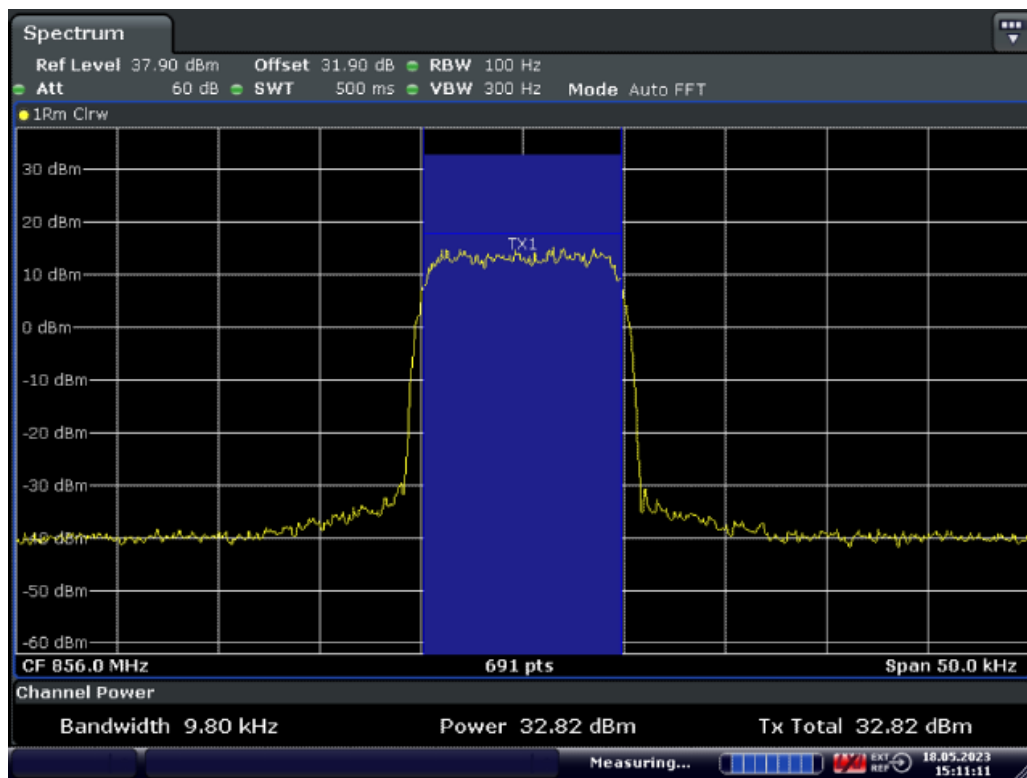

Date: 18.MAY.2023 15:11:11

Middle Frequency: 856.0MHz, Output occupied BW(AGC)

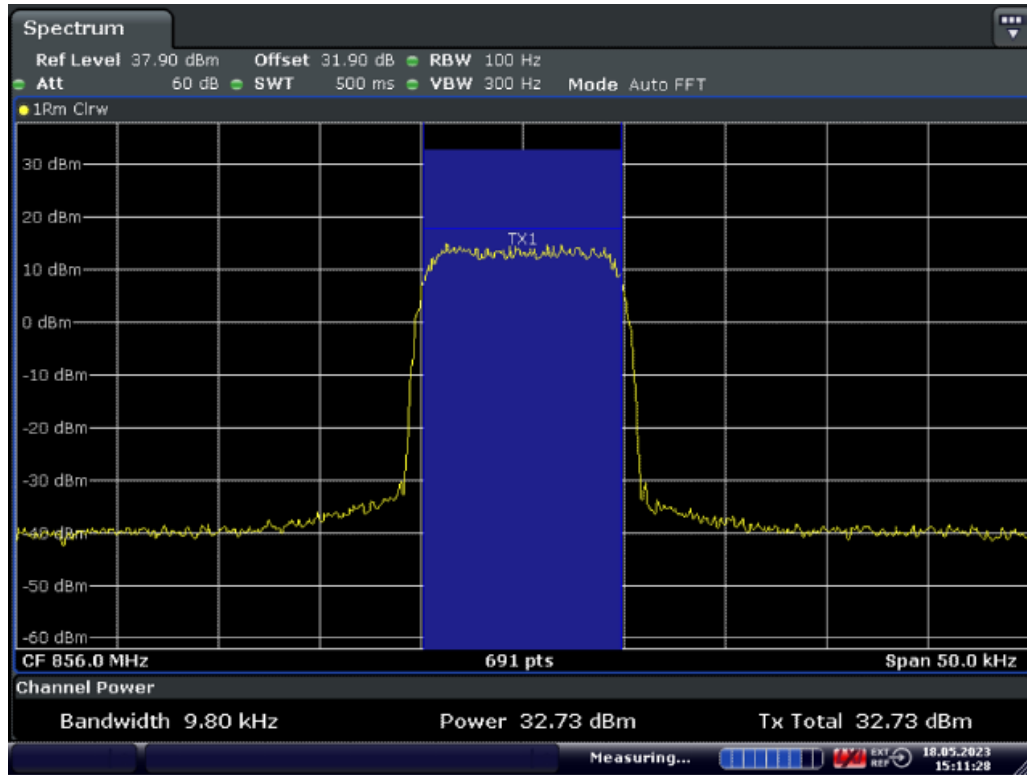

Date: 18.MAY.2023 15:11:28

Middle Frequency: 856.0MHz, Output occupied BW (with the input signal amplitude set 3 dB above the AGC threshold)

11.5.5.3.2.2.2. Uplink

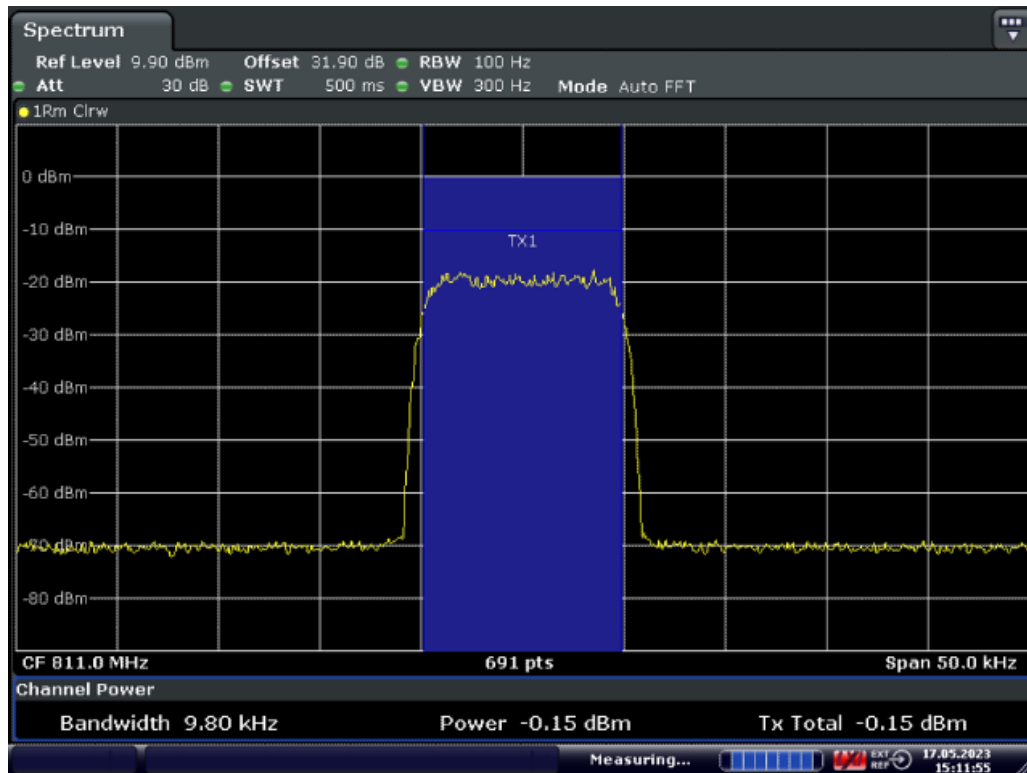

Date: 17.MAY.2023 15:11:55

Middle Frequency: 811.0MHz MHz, Input occupied BW

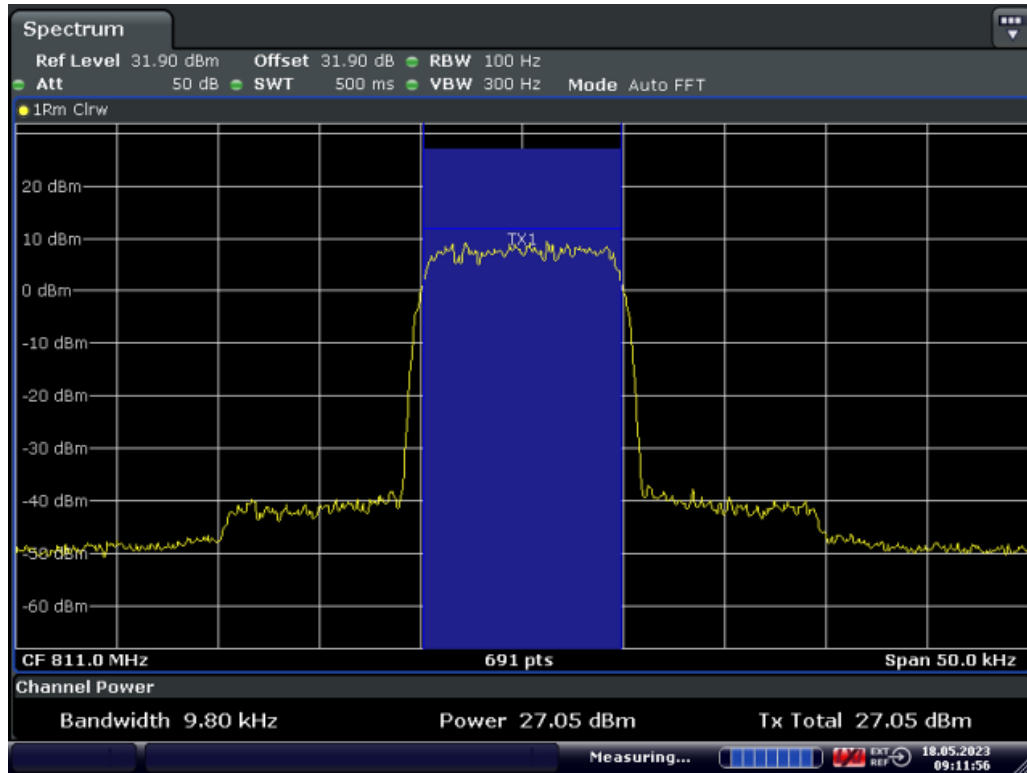

Date: 18.MAY.2023 09:11:56

Middle Frequency: 811.0MHz, Output occupied BW(AGC)

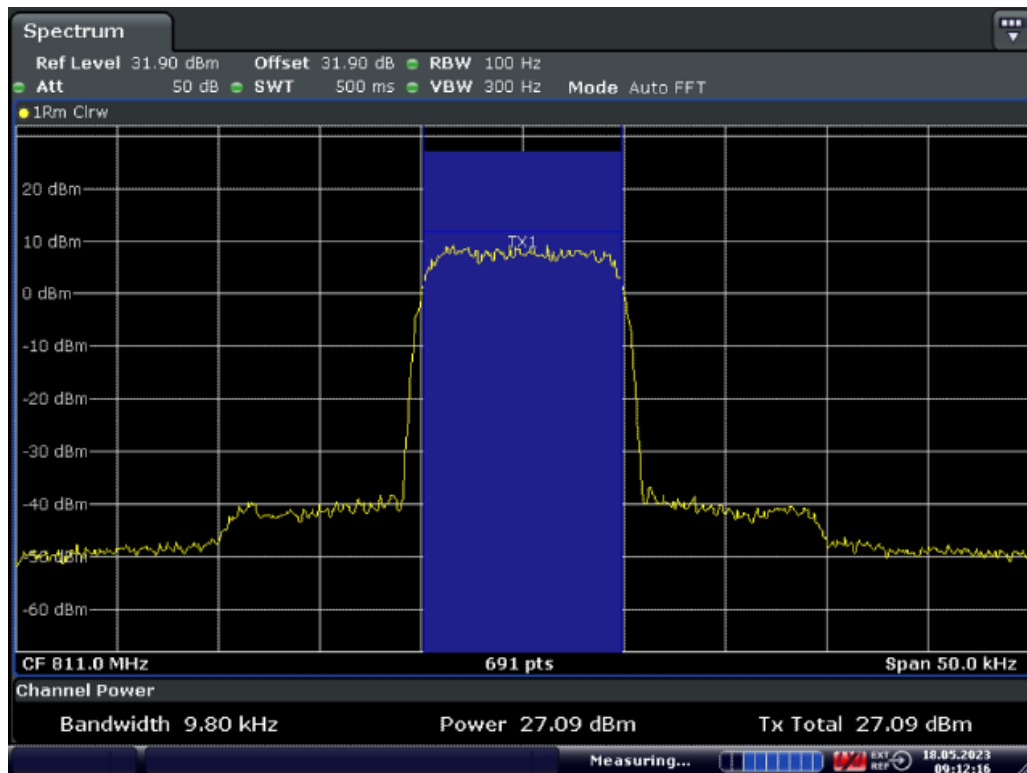

Date: 18.MAY.2023 09:12:17

Middle Frequency: 811.0MHz, Output occupied BW (with the input signal amplitude set 3 dB above the AGC threshold)

11.5.5.3.2.3. DMR

11.5.5.3.2.3.1. Downlink

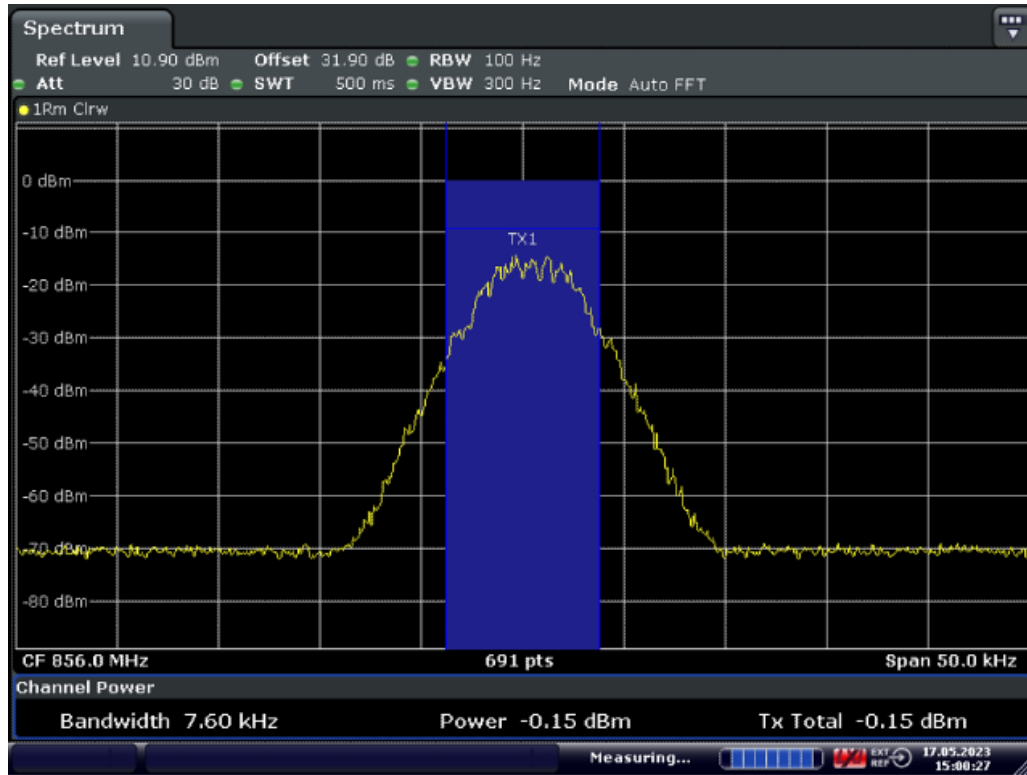

Date: 17.MAY.2023 15:00:28

Middle Frequency: 856.0MHz, Input occupied BW

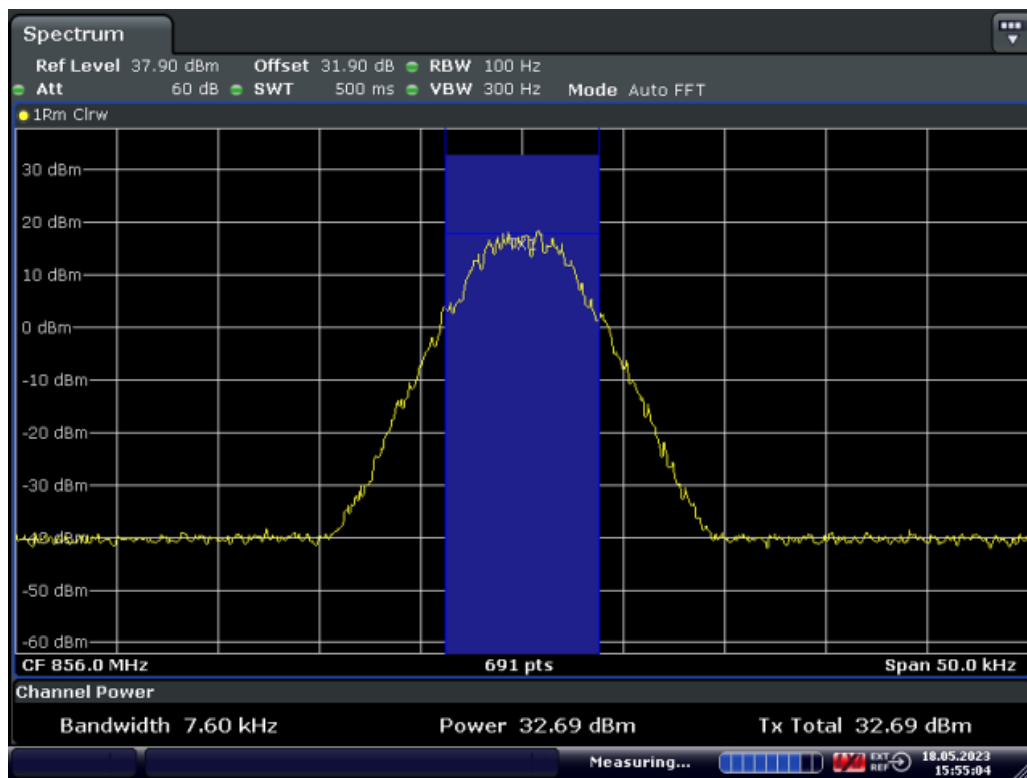

Date: 18.MAY.2023 15:55:04

Middle Frequency: 856.0MHz, Output occupied BW(AGC)

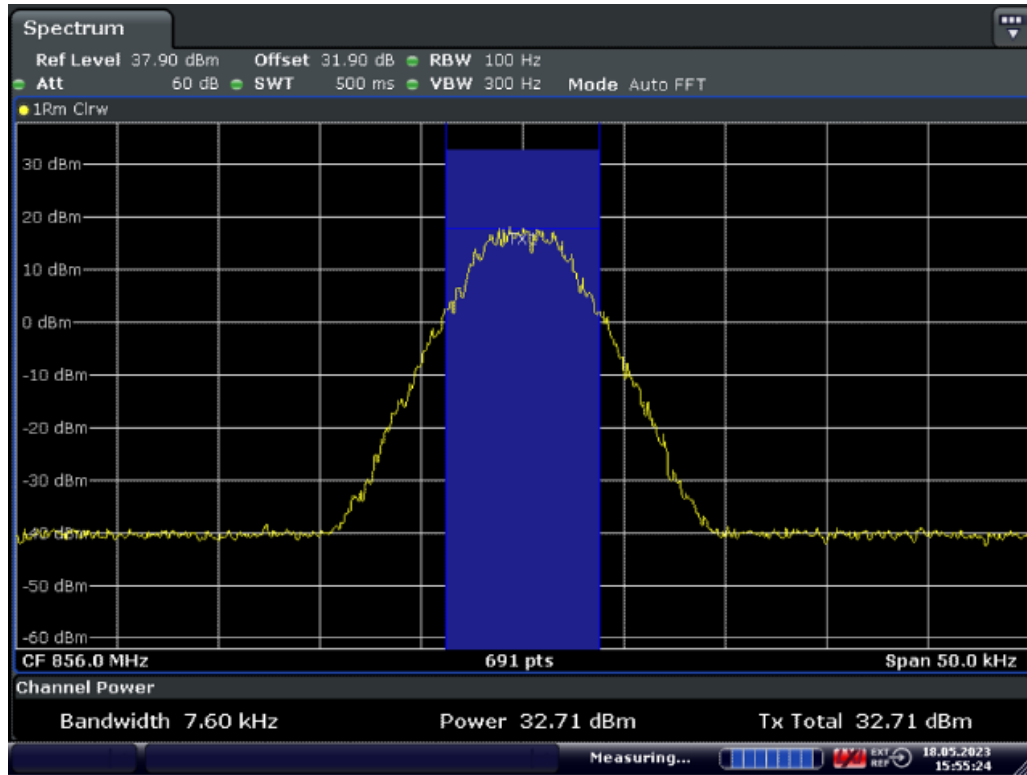

Date: 18.MAY.2023 15:55:25

Middle Frequency: 856.0MHz, Output occupied BW (with the input signal amplitude set 3 dB above the AGC threshold)

11.5.5.3.2.3.2. Uplink

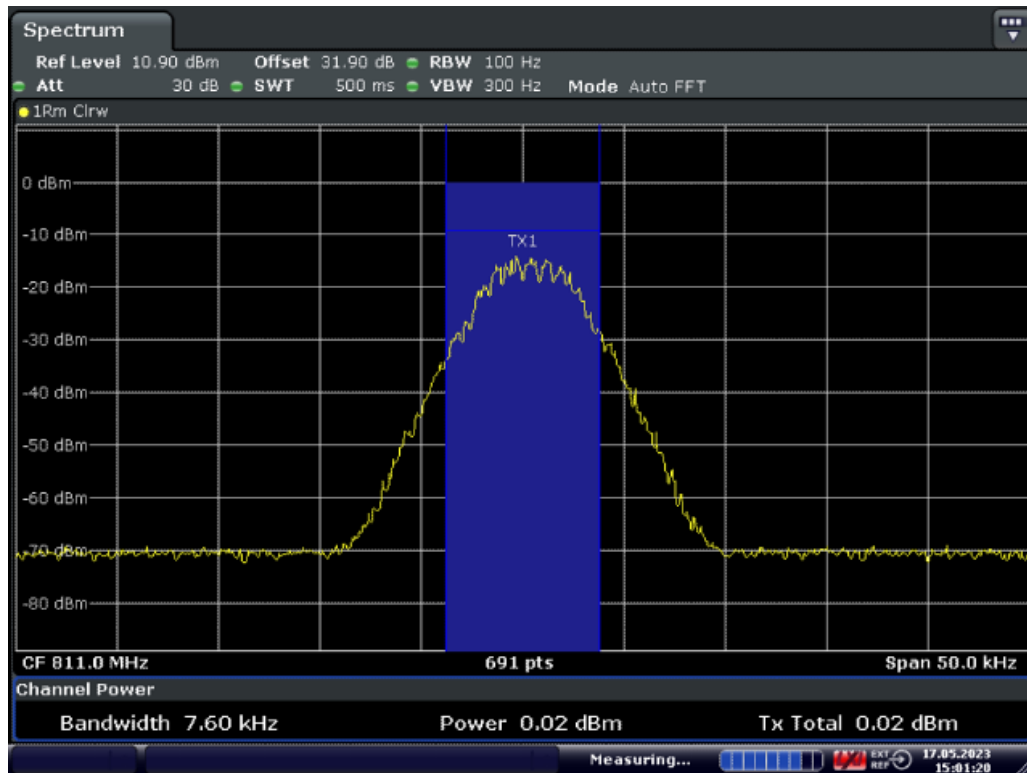

Date: 17.MAY.2023 15:01:20

Middle Frequency: 811.0MHz MHz, Input occupied BW

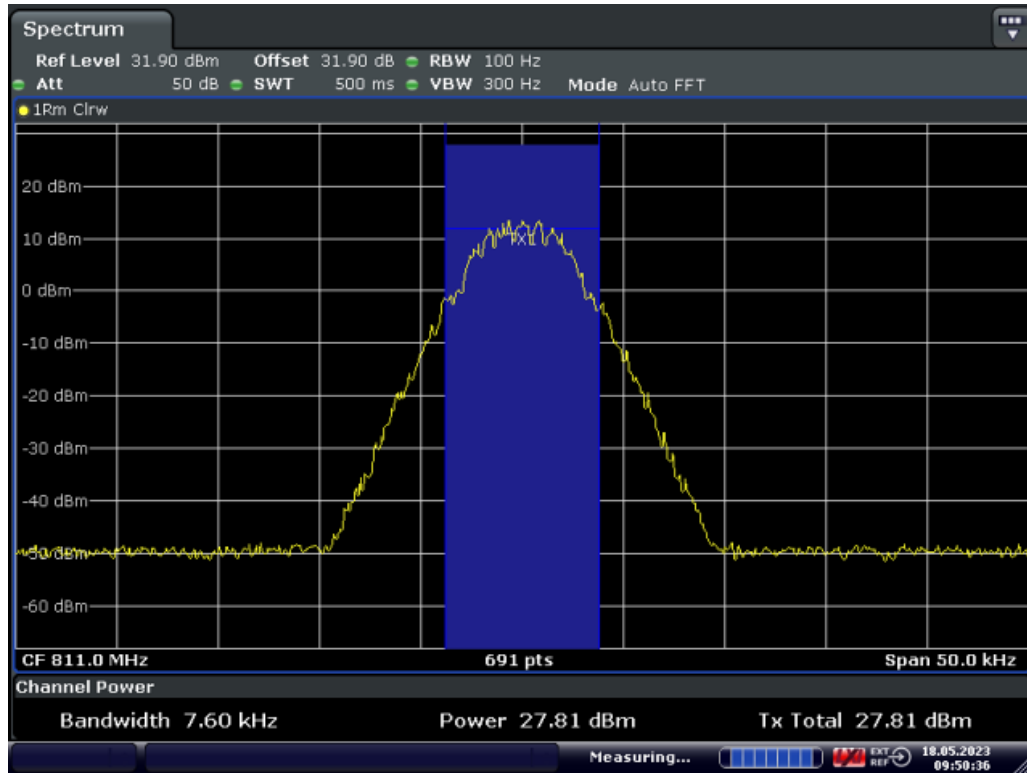

Date: 18.MAY.2023 09:50:37

Middle Frequency: 811.0MHz, Output occupied BW(AGC)

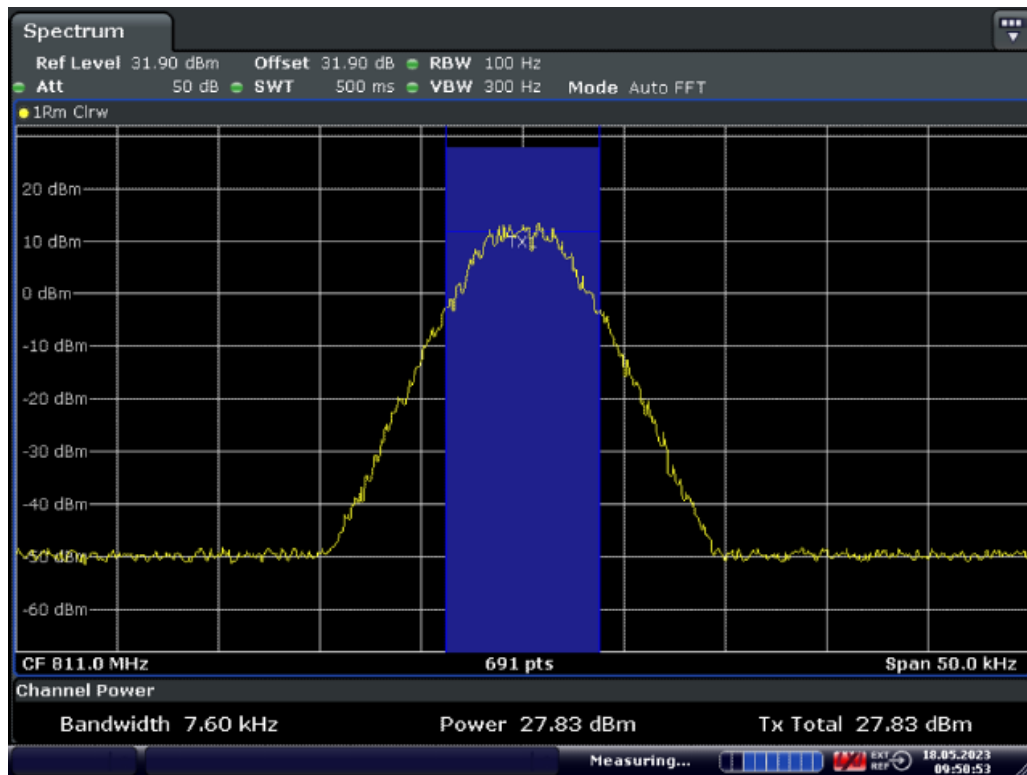

Date: 18.MAY.2023 09:50:54

Middle Frequency: 811.0MHz, Output occupied BW (with the input signal amplitude set 3 dB above the AGC threshold)

11.5.5.3.2.4. Analog FM

11.5.5.3.2.4.1. Downlink

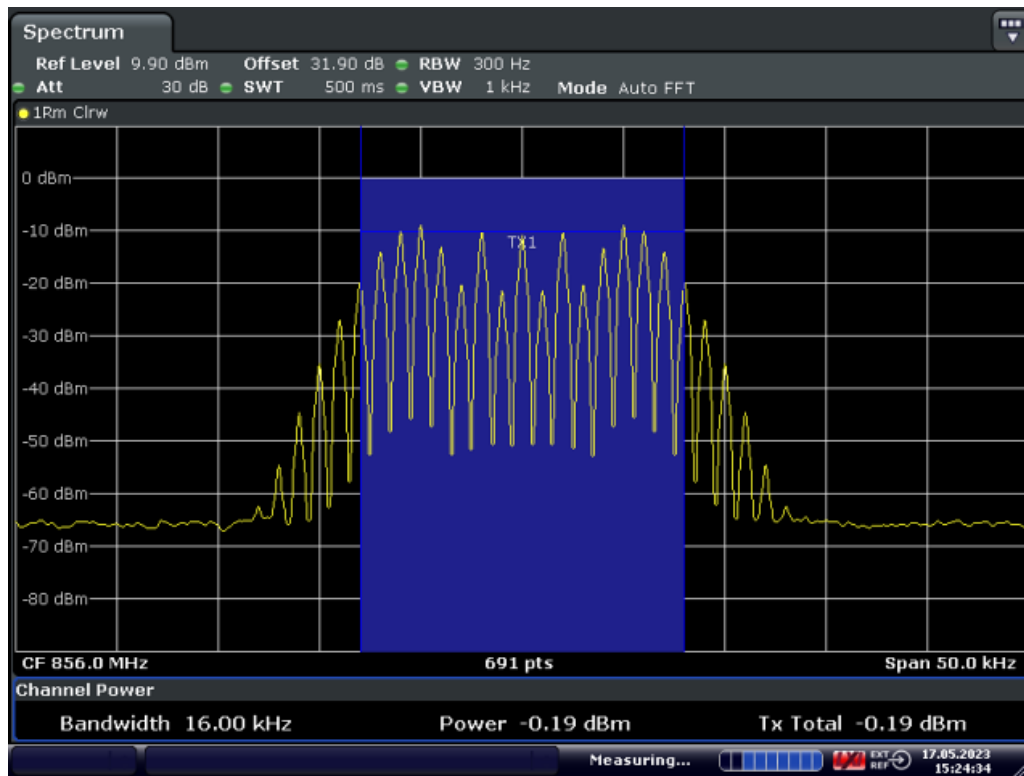

Date: 17.MAY.2023 15:24:34

Middle Frequency: 856.0MHz, Input occupied BW

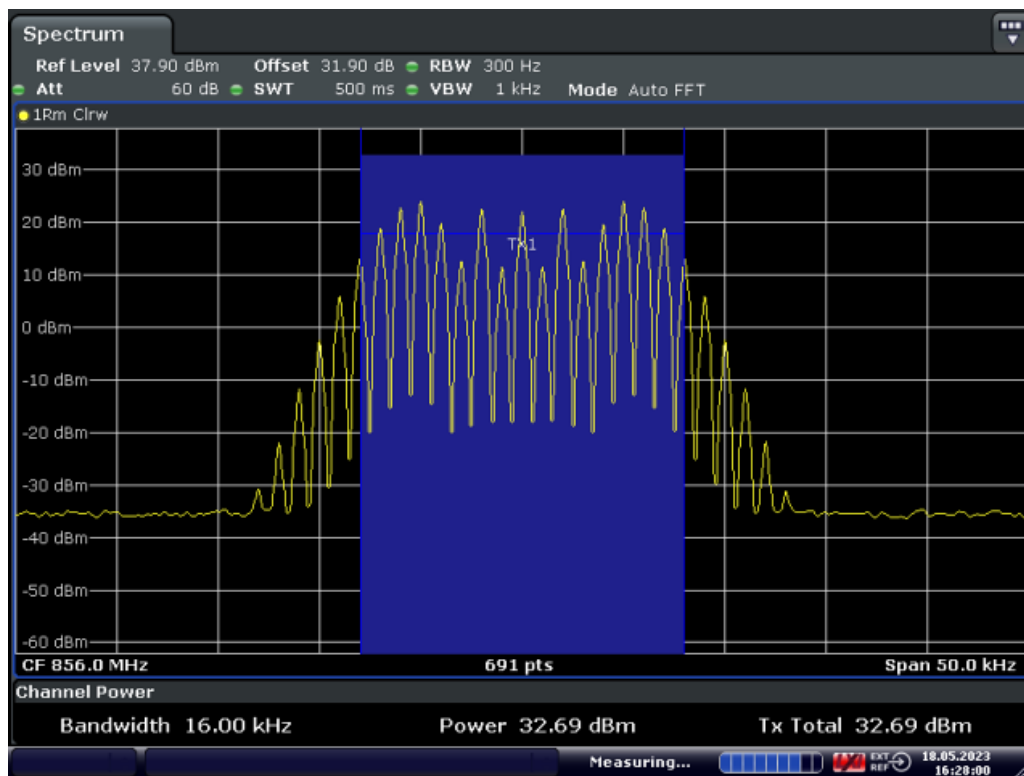

Date: 18.MAY.2023 16:28:00

Middle Frequency: 856.0MHz, Output occupied BW(AGC)

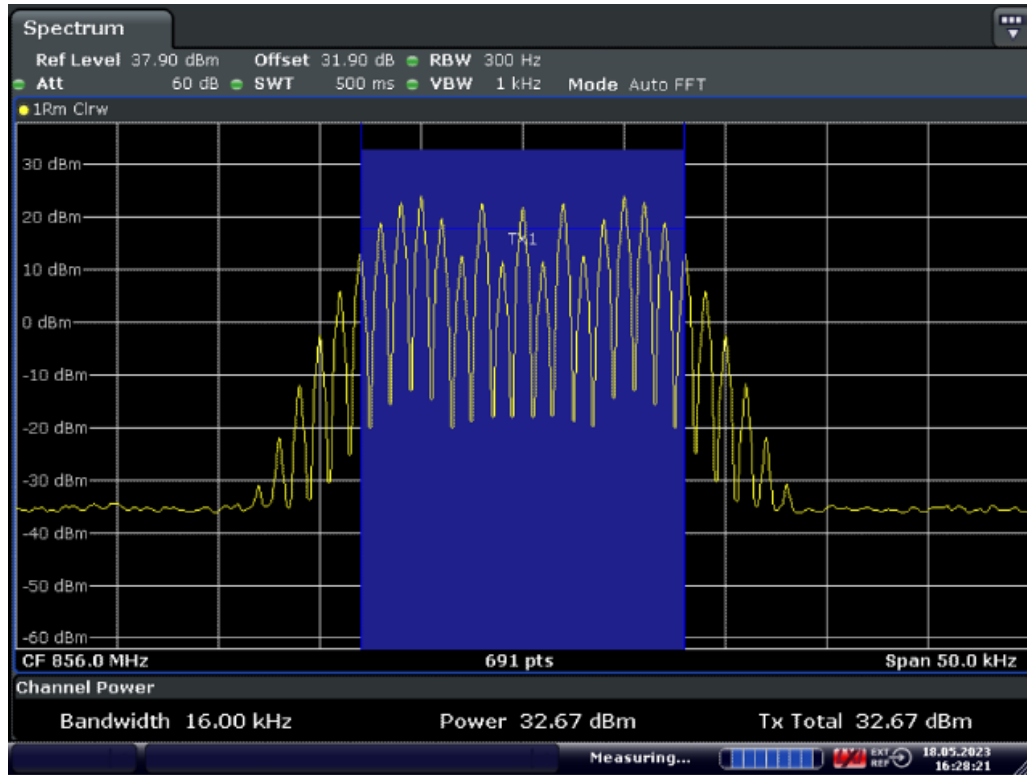

Date: 18.MAY.2023 16:28:21

Middle Frequency: 856.0MHz, Output occupied BW (with the input signal amplitude set 3 dB above the AGC threshold)

11.5.5.3.2.4.2. Uplink

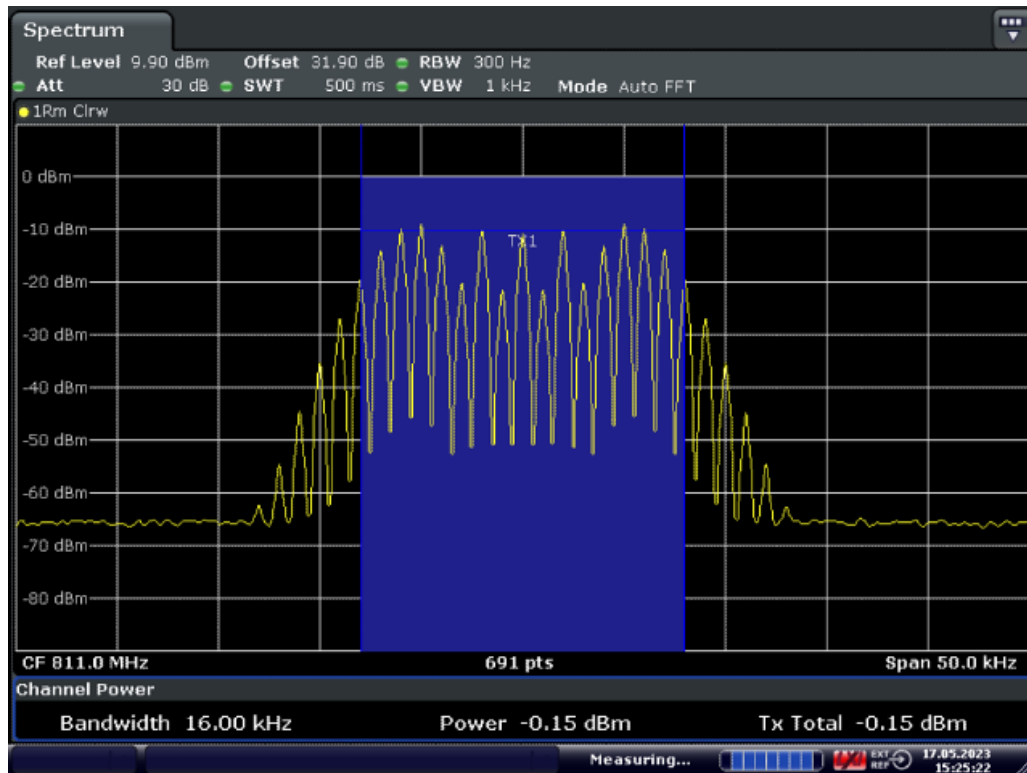

Date: 17.MAY.2023 15:25:22

Middle Frequency: 811.0MHz MHz, Input occupied BW

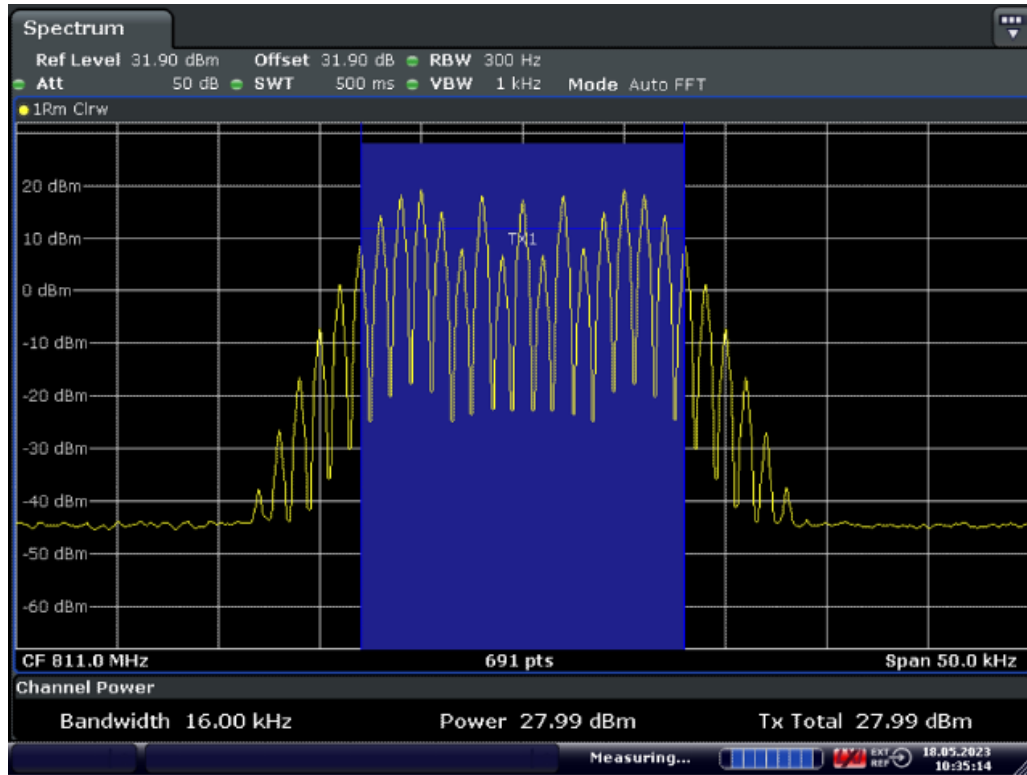

Date: 18.MAY.2023 10:35:15

Middle Frequency: 811.0MHz, Output occupied BW(AGC)

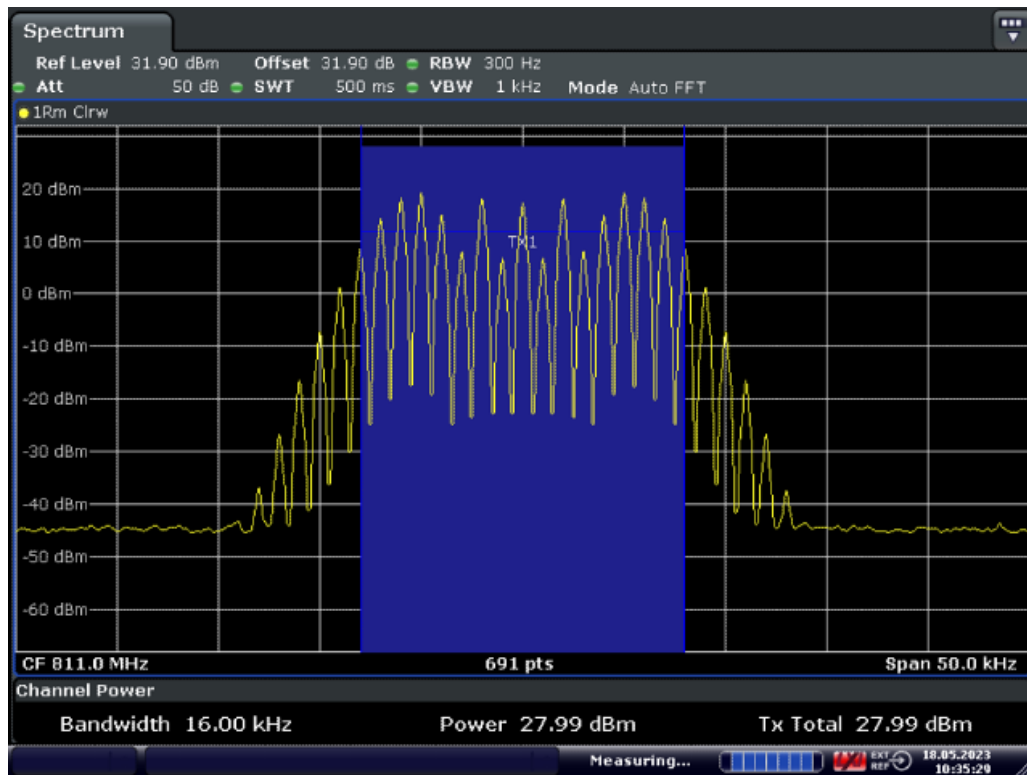

Date: 18.MAY.2023 10:35:29

Middle Frequency: 811.0MHz, Output occupied BW (with the input signal amplitude set 3 dB above the AGC threshold)

11.5.5.3.2.5. Tetra

11.5.5.3.2.5.1. Downlink

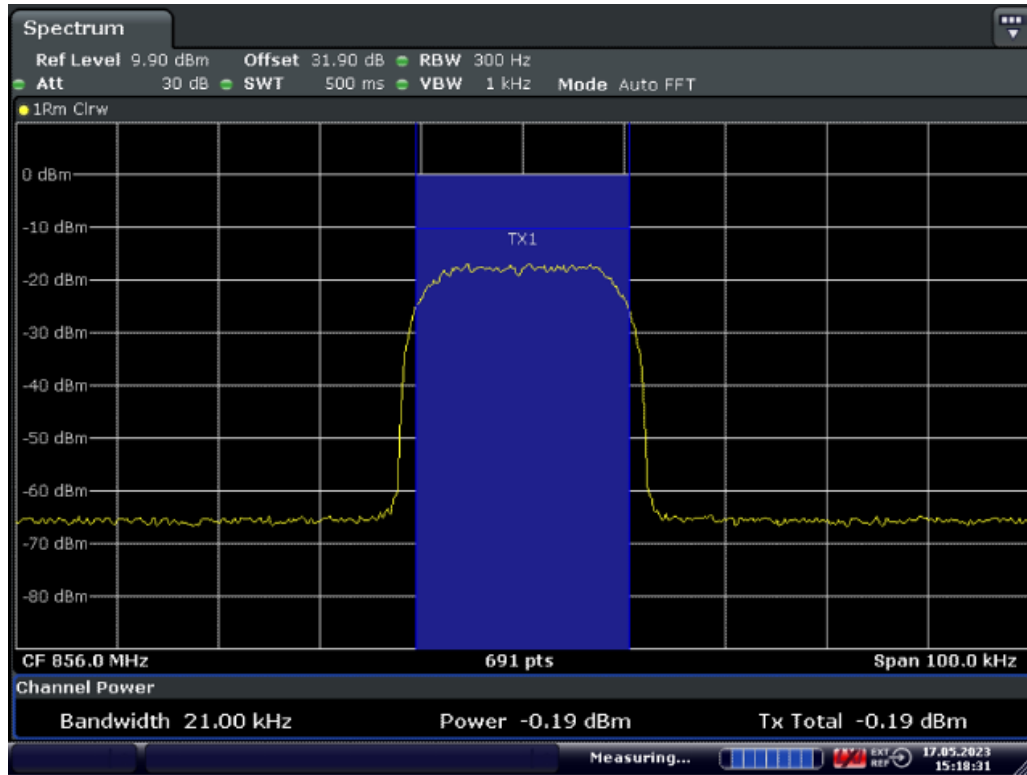

Date: 17.MAY.2023 15:18:32

Middle Frequency: 856.0MHz, Input occupied BW

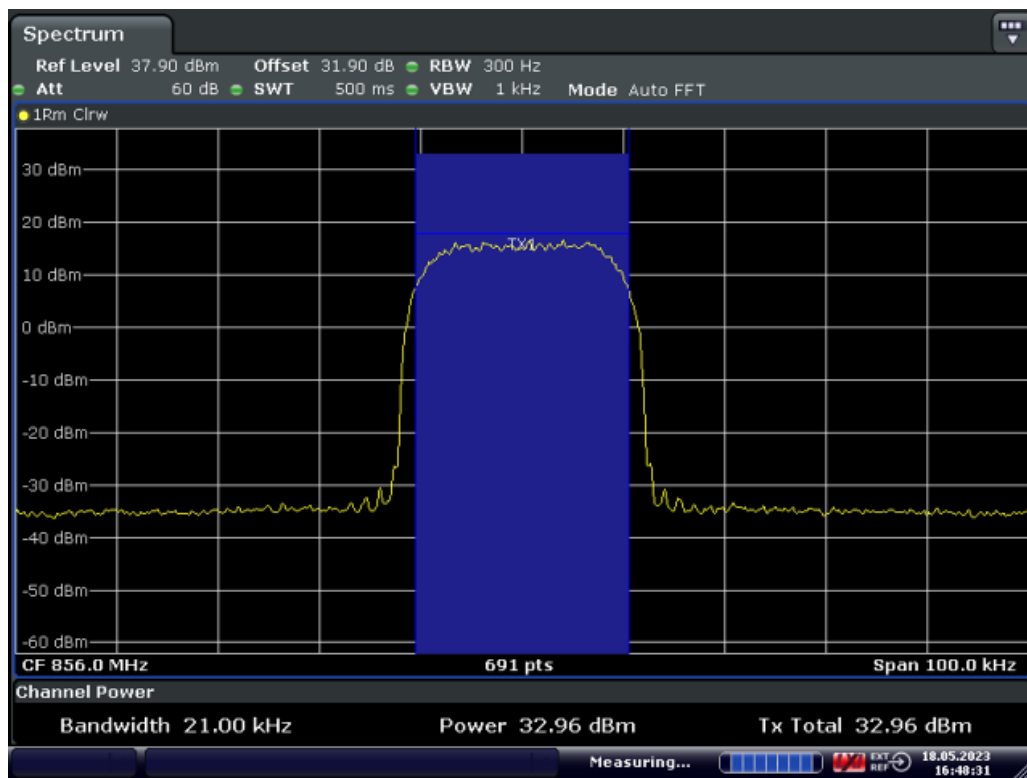

Date: 18.MAY.2023 16:48:31

Middle Frequency: 856.0MHz, Output occupied BW(AGC)

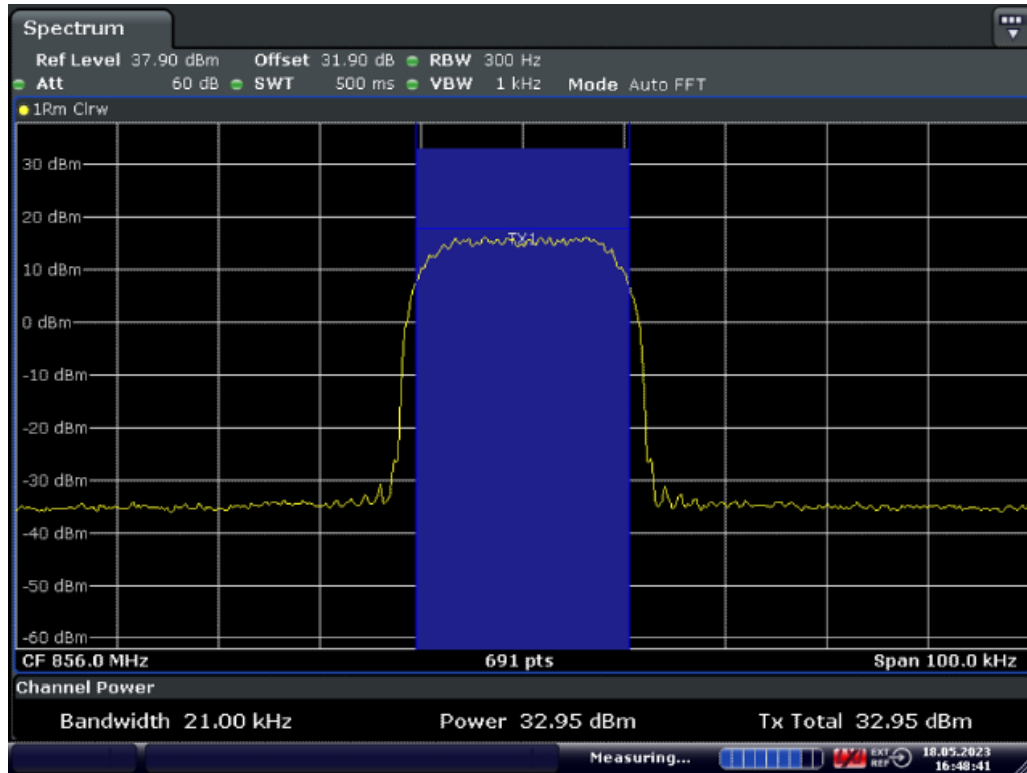

Date: 18.MAY.2023 16:48:42

Middle Frequency: 856.0MHz, Output occupied BW (with the input signal amplitude set 3 dB above the AGC threshold)

11.5.5.3.2.5.2. Uplink

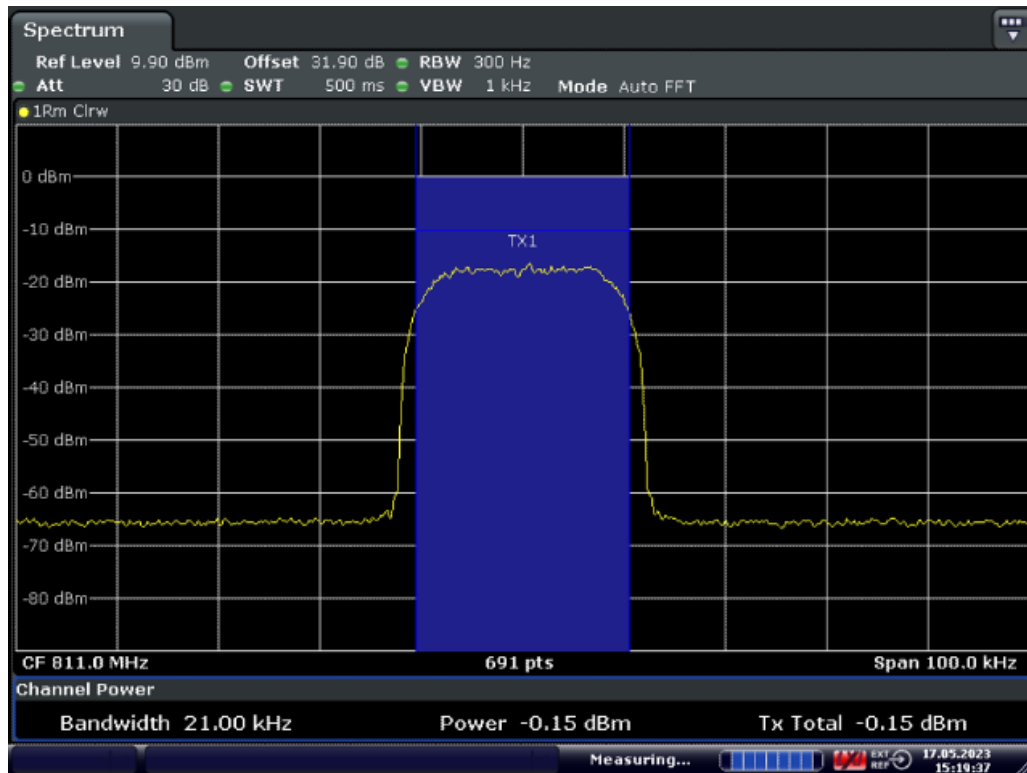

Date: 17.MAY.2023 15:19:37

Middle Frequency: 811.0MHz MHz, Input occupied BW

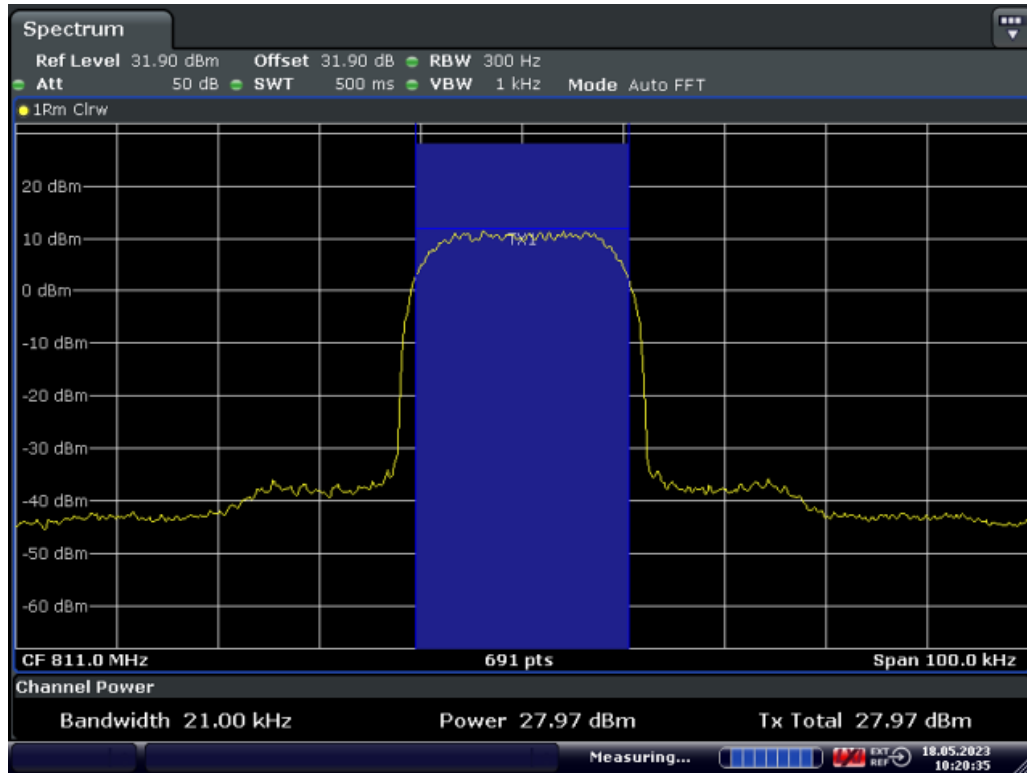

Date: 18.MAY.2023 10:20:36

Middle Frequency: 811.0MHz, Output occupied BW(AGC)

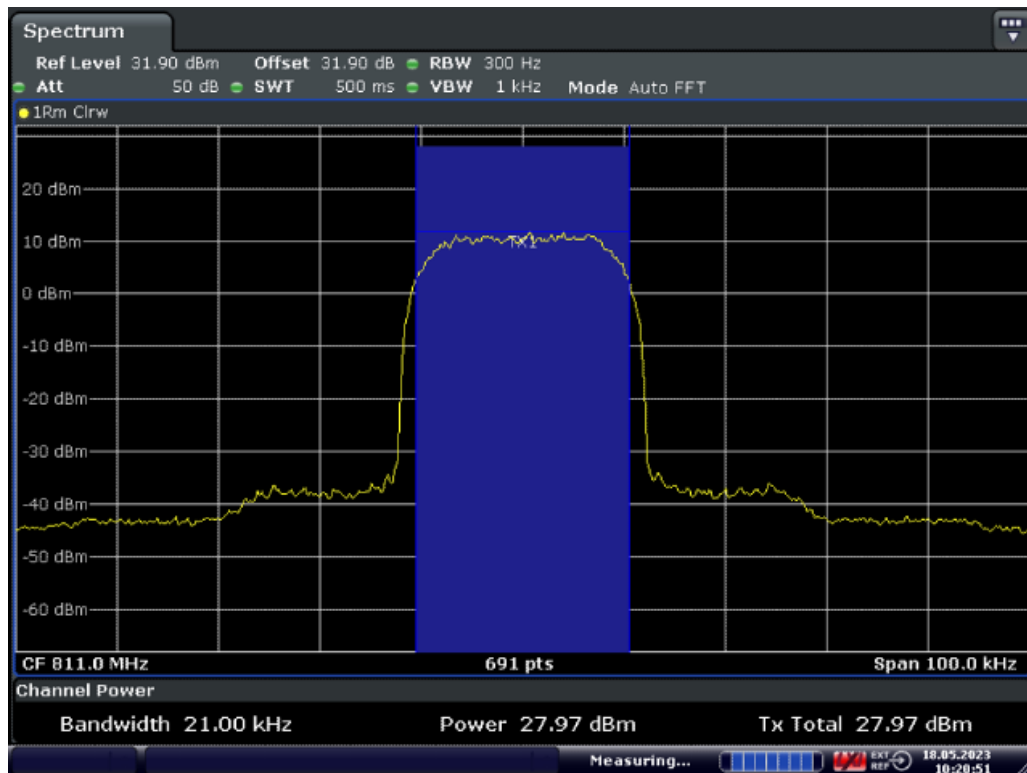

Date: 18.MAY.2023 10:20:52

Middle Frequency: 811.0MHz, Output occupied BW (with the input signal amplitude set 3 dB above the AGC threshold)

11.6. Mean power and amplifier/booster gain

Test requirement: KDB 935210 D05 clause 4.5
 FCC PART 90.219 (e)(1)
 Test Method: KDB 935210 D05 clause 4.5

11.6.1. Requirements

According to KDB 935210 D05 clause 4.5, the mean input and output power and the amplifier gain was measured by adjusting the internal gain control of the EUT to the maximum gain for which equipment certification is sought. Any EUT attenuation settings were set to their minimum value.

Input power levels (Downlink and Uplink) were set to maximum input ratings while confirming that the device is not capable of operating in saturation (Non-linear mode) at the rated input levels, including during the performance of the input/output power measurements.

For FCC PART 90.219 (e)(1) requirement:

(e) Device Specifications. In addition to the general rules for equipment certification in §90.203(a)(2) and part 2, subpart J of this chapter, a signal booster must also meet the rules in this paragraph.

(1) The output power capability of a signal booster must be designed for deployments providing a radiated power not exceeding 5 Watts ERP for each retransmitted channel.

11.6.2. Test configuration

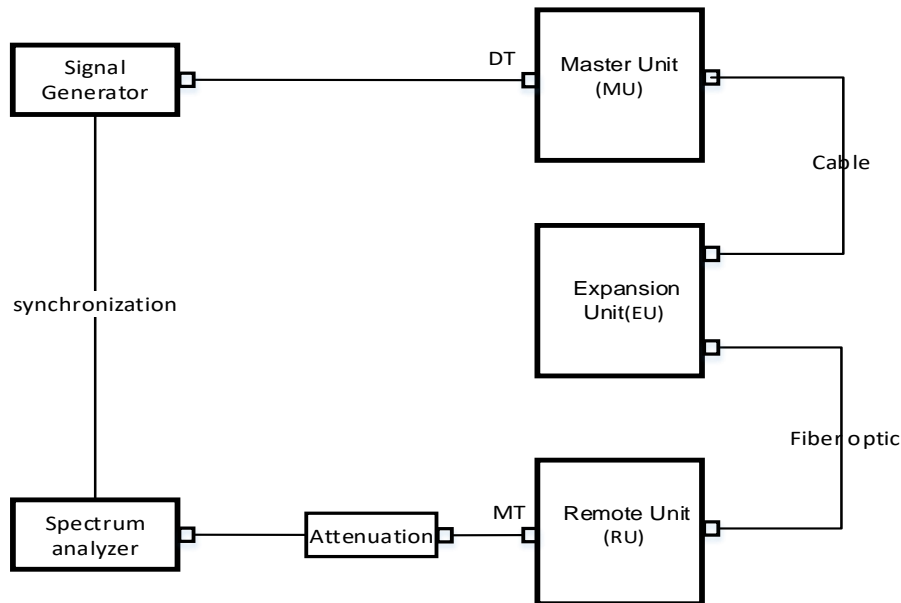

Figure 11.6-1 Downlink connection diagram

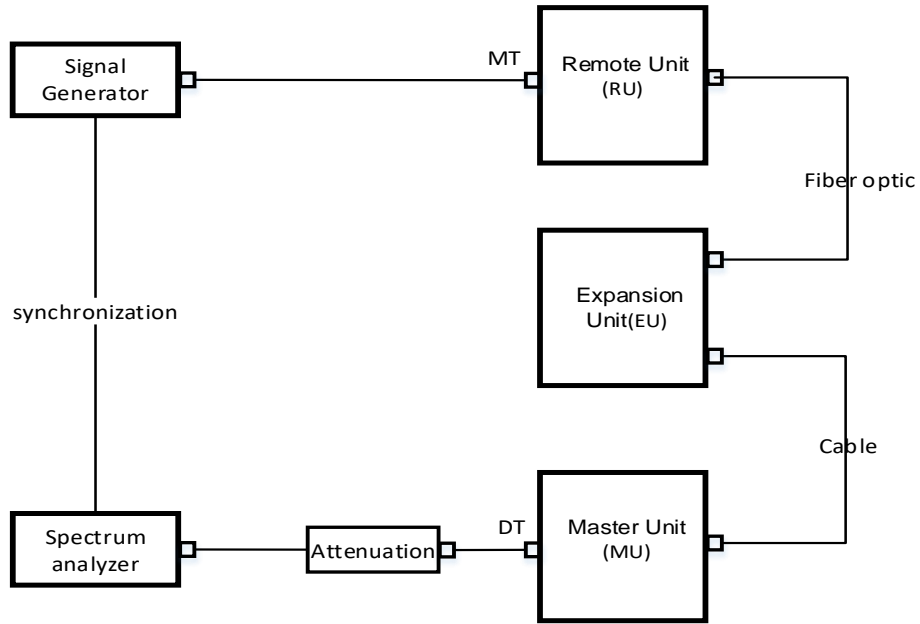

Figure 11.6-2 Uplink connection diagram

----- The following blanks -----

11.6.3. Test procedures

- a) Connect a signal generator to the input of the EUT.
- b) Configure to generate the AWGN (broadband) test signal.
- c) The frequency of the signal generator shall be set to the frequency f_0 as determined from 3.3.
- d) Connect a spectrum analyzer or power meter to the output of the EUT using appropriate attenuation as necessary.
- e) Set the signal generator output power to a level that produces an EUT output level that is just below the AGC threshold (see 3.2), but not more than 0.5 dB below.
- f) Measure and record the output power of the EUT; use 3.5.3 or 3.5.4 for power measurement.
- g) Remove the EUT from the measurement setup. Using the same signal generator settings, repeat the power measurement at the signal generator port, which was used as the input signal to the EUT, and record as the input power. EUT gain may be calculated as described in 3.5.5.
- h) Repeat steps f) and g) with input signal amplitude set to 3 dB above the AGC threshold level.
- i) Repeat steps e) to h) with the narrowband test signal.
- j) Repeat steps e) to i) for all frequency bands authorized for use by the EUT.

----- The following blanks -----

11.6.4. Test results

Test Date (yy-mm-dd): 2023-05-18

Normal condition: Temp:27.2°C, Humid: 57%, Atmospheric Pressure:101kpa

Supply Voltage: AC 110V, 50Hz

11.6.4.1. Mean power and gain

11.6.4.1.1. 700MHz Band

11.6.4.1.1.1. Downlink

Test link	Frequency (MHz)	Sig output power (dBm)	Input Cable Loss (dB)	Peak power (dBm)	Output Atten +Output Cable Loss(dB)	Output power (dBm)	Output power (W)	Gain (dB)
1. P25 Phase I(C4FM)								
Down ⁽¹⁾	769.00625	-55.0	1.1	-0.7	31.9	31.2	1.3	87.3
Down ⁽²⁾	769.00625	-52.0	1.1	-0.7	31.9	31.2	1.3	84.3
Down ⁽¹⁾	772.0	-57.0	1.1	0.7	31.9	32.6	1.8	90.7
Down ⁽²⁾	772.0	-54.0	1.1	0.7	31.9	32.6	1.8	87.7
Down ⁽¹⁾	774.99375	-55.0	1.1	-1.1	31.9	30.8	1.2	86.9
Down ⁽²⁾	774.99375	-52.0	1.1	-1.1	31.9	30.8	1.2	83.9
2. P25 Phase II(H-DQPSK)								
Down ⁽¹⁾	769.00625	-54.9	1.1	-0.7	31.9	31.2	1.3	87.2
Down ⁽²⁾	769.00625	-51.9	1.1	-0.7	31.9	31.2	1.3	84.2
Down ⁽¹⁾	772.0	-57.1	1.1	0.5	31.9	32.4	1.7	90.6
Down ⁽²⁾	772.0	-54.1	1.1	0.5	31.9	32.4	1.7	87.6
Down ⁽¹⁾	774.99375	-55.5	1.1	-1.5	31.9	30.4	1.1	87.0
Down ⁽²⁾	774.99375	-52.5	1.1	-1.5	31.9	30.4	1.1	84.0
3. DMR								
Down ⁽¹⁾	769.00625	-55.0	1.1	-0.9	31.9	31.0	1.3	87.1
Down ⁽²⁾	769.00625	-52.0	1.1	-0.9	31.9	31.0	1.3	84.1
Down ⁽¹⁾	772.0	-57.0	1.1	0.5	31.9	32.4	1.7	90.5
Down ⁽²⁾	772.0	-54.0	1.1	0.5	31.9	32.4	1.7	87.5
Down ⁽¹⁾	774.99375	-55.3	1.1	-1.4	31.9	30.5	1.1	86.9
Down ⁽²⁾	774.99375	-52.3	1.1	-1.4	31.9	30.5	1.1	83.9
4. Analog FM								
Down ⁽¹⁾	769.0125	-54.9	1.1	-0.7	31.9	31.2	1.3	87.2

Down ⁽²⁾	769.0125	-51.9	1.1	-0.7	31.9	31.2	1.3	84.2
Down ⁽¹⁾	772.0	-56.9	1.1	0.7	31.9	32.6	1.8	90.6
Down ⁽²⁾	772.0	-53.9	1.1	0.7	31.9	32.6	1.8	87.6
Down ⁽¹⁾	774.9875	-55.5	1.1	-1.5	31.9	30.4	1.1	87.0
Down ⁽²⁾	774.9875	-52.5	1.1	-1.5	31.9	30.4	1.1	84.0
5. Tetra								
Down ⁽¹⁾	769.0125	-55.0	1.1	-0.7	31.9	31.2	1.3	87.3
Down ⁽²⁾	769.0125	-52.0	1.1	-0.7	31.9	31.2	1.3	84.3
Down ⁽¹⁾	772.0	-57.0	1.1	0.7	31.9	32.6	1.8	90.7
Down ⁽²⁾	772.0	-54.0	1.1	0.7	31.9	32.6	1.8	87.7
Down ⁽¹⁾	774.9875	-55.3	1.1	-1.2	31.9	30.7	1.2	87.1
Down ⁽²⁾	774.9875	-52.3	1.1	-1.2	31.9	30.7	1.2	84.1

NOTE: ⁽¹⁾ Level is 0.5 dB below AGC threshold; ⁽²⁾ Level is 3dB above AGC threshold.

11.6.4.1.1.2. Uplink

Test link	Frequency (MHz)	Sig output power (dBm)	Input Cable Loss (dB)	Peak power (dBm)	Output Atten +Output Cable Loss(dB)	Output power (dBm)	Output power (W)	Gain (dB)
1. P25 Phase I(C4FM)								
Up ⁽¹⁾	799.00625	-60.0	1.1	-6.0	31.9	25.9	0.4	87.0
Up ⁽²⁾	799.00625	-57.0	1.1	-6.0	31.9	25.9	0.4	84.0
Up ⁽¹⁾	802.0	-62.0	1.1	-4.4	31.9	27.5	0.6	90.6
Up ⁽²⁾	802.0	-59.0	1.1	-4.4	31.9	27.5	0.6	87.6
Up ⁽¹⁾	804.99375	-62.6	1.1	-4.4	31.9	27.5	0.6	91.2
Up ⁽²⁾	804.99375	-59.6	1.1	-4.4	31.9	27.5	0.6	88.2
2. P25 Phase II(H-DQPSK)								
Up ⁽¹⁾	799.00625	-59.6	1.1	-6.6	31.9	25.7	0.3	86.4
Up ⁽²⁾	799.00625	-56.6	1.1	-6.6	31.9	25.7	0.3	83.4
Up ⁽¹⁾	802.0	-62.0	1.1	-4.9	31.9	27.6	0.5	90.7
Up ⁽²⁾	802.0	-59.0	1.1	-4.9	31.9	27.6	0.5	87.7
Up ⁽¹⁾	804.99375	-62.5	1.1	-5.0	31.9	27.8	0.5	91.4
Up ⁽²⁾	804.99375	-59.5	1.1	-5.0	31.9	27.8	0.5	88.4
3. DMR								
Up ⁽¹⁾	799.00625	-60.2	1.1	-5.8	31.9	26.1	0.4	87.4

Up ⁽²⁾	799.00625	-57.2	1.1	-5.8	31.9	26.1	0.4	84.4
Up ⁽¹⁾	802.0	-62.2	1.1	-4.2	31.9	27.7	0.6	91.0
Up ⁽²⁾	802.0	-59.2	1.1	-4.2	31.9	27.7	0.6	88.0
Up ⁽¹⁾	804.99375	-62.6	1.1	-3.9	31.9	28.0	0.6	91.7
Up ⁽²⁾	804.99375	-59.6	1.1	-3.9	31.9	28.0	0.6	88.7
4. Analog FM								
Up ⁽¹⁾	799.0125	-61.3	1.1	-5.0	31.9	26.3	0.5	89.3
Up ⁽²⁾	799.0125	-58.3	1.1	-5.0	31.9	26.3	0.5	86.3
Up ⁽¹⁾	802.0	-62.6	1.1	-4.0	31.9	27.9	0.6	91.6
Up ⁽²⁾	802.0	-59.6	1.1	-4.0	31.9	27.9	0.6	88.6
Up ⁽¹⁾	804.9875	-62.9	1.1	-3.9	31.9	28.0	0.6	92.0
Up ⁽²⁾	804.9875	-59.9	1.1	-3.9	31.9	28.0	0.6	89.0
5. Tetra								
Up ⁽¹⁾	799.0125	-60.1	1.1	-5.2	31.9	26.7	0.5	87.9
Up ⁽²⁾	799.0125	-57.1	1.1	-5.2	31.9	26.7	0.5	84.9
Up ⁽¹⁾	802.0	-62.3	1.1	-3.9	31.9	28.0	0.6	91.4
Up ⁽²⁾	802.0	-59.3	1.1	-3.9	31.9	28.0	0.6	88.4
Up ⁽¹⁾	804.9875	-62.8	1.1	-3.9	31.9	28.0	0.6	91.9
Up ⁽²⁾	804.9875	-59.8	1.1	-3.9	31.9	28.0	0.6	88.9

NOTE: ⁽¹⁾ Level is 0.5 dB below AGC threshold; ⁽²⁾ Level is 3dB above AGC threshold.

----- The following blanks -----

11.6.4.1.2. 800MHz Band

11.6.4.1.2.1. Downlink

Test link	Frequency (MHz)	Sig output power (dBm)	Input Cable Loss (dB)	Peak power (dBm)	Output Atten +Output Cable Loss(dB)	Output power (dBm)	Output power (W)	Gain (dB)
1. P25 Phase I(C4FM)								
Down ⁽¹⁾	851.00625	-53.6	1.1	-2.5	31.9	29.4	0.9	84.1
Down ⁽²⁾	851.00625	-50.6	1.1	-2.5	31.9	29.4	0.9	81.1
Down ⁽¹⁾	856.0	-55.8	1.1	1.0	31.9	32.9	1.9	89.8
Down ⁽²⁾	856.0	-52.8	1.1	1.0	31.9	32.9	1.9	86.8
Down ⁽¹⁾	860.99375	-55.3	1.1	-0.3	31.9	31.6	1.4	88.0
Down ⁽²⁾	860.99375	-52.3	1.1	-0.3	31.9	31.6	1.4	85.0
2. P25 Phase II(H-DQPSK)								
Down ⁽¹⁾	851.00625	-53.7	1.1	-2.7	31.9	29.2	0.8	84.0
Down ⁽²⁾	851.00625	-50.7	1.1	-2.7	31.9	29.2	0.8	81.0
Down ⁽¹⁾	856.0	-55.8	1.1	0.9	31.9	32.8	1.9	89.7
Down ⁽²⁾	856.0	-52.8	1.1	0.9	31.9	32.8	1.9	86.7
Down ⁽¹⁾	860.99375	-55.3	1.1	-0.5	31.9	31.4	1.4	87.8
Down ⁽²⁾	860.99375	-52.3	1.1	-0.5	31.9	31.4	1.4	84.8
3. DMR								
Down ⁽¹⁾	851.00625	-53.5	1.1	-2.6	31.9	29.3	0.9	83.9
Down ⁽²⁾	851.00625	-50.5	1.1	-2.6	31.9	29.3	0.9	80.9
Down ⁽¹⁾	856.0	-55.7	1.1	0.8	31.9	32.7	1.9	89.5
Down ⁽²⁾	856.0	-52.7	1.1	0.8	31.9	32.7	1.9	86.5
Down ⁽¹⁾	860.99375	-55.2	1.1	-0.4	31.9	31.5	1.4	87.8
Down ⁽²⁾	860.99375	-52.2	1.1	-0.4	31.9	31.5	1.4	84.8
4. Analog FM mode								
Down ⁽¹⁾	851.0125	-53.8	1.1	-2.7	31.9	29.2	0.8	84.1
Down ⁽²⁾	851.0125	-50.8	1.1	-2.7	31.9	29.2	0.8	81.1
Down ⁽¹⁾	856.0	-55.9	1.1	0.8	31.9	32.7	1.9	89.7
Down ⁽²⁾	856.0	-52.9	1.1	0.8	31.9	32.7	1.9	86.7
Down ⁽¹⁾	860.9875	-55.5	1.1	-0.5	31.9	31.4	1.4	88.0
Down ⁽²⁾	860.9875	-52.5	1.1	-0.5	31.9	31.4	1.4	85.0
5. Tetra								

Down ⁽¹⁾	851.0125	-53.7	1.1	-2.6	31.9	29.3	0.9	84.1
Down ⁽²⁾	851.0125	-50.7	1.1	-2.6	31.9	29.3	0.9	81.1
Down ⁽¹⁾	856.0	-55.7	1.1	1.1	31.9	33.0	2.0	89.8
Down ⁽²⁾	856.0	-52.7	1.1	1.1	31.9	33.0	2.0	86.8
Down ⁽¹⁾	860.9875	-55.3	1.1	-0.3	31.9	31.6	1.4	88.0
Down ⁽²⁾	860.9875	-52.3	1.1	-0.3	31.9	31.6	1.4	85.0

NOTE: ⁽¹⁾ Level is 0.5 dB below AGC threshold; ⁽²⁾ Level is 3dB above AGC threshold.

11.6.4.1.2.2. Uplink

Test link	Frequency (MHz)	Sig output power (dBm)	Input Cable Loss (dB)	Peak power (dBm)	Output Atten +Output Cable Loss(dB)	Output power (dBm)	Output power (W)	Gain (dB)
1. P25 Phase I(C4FM)								
Up ⁽¹⁾	806.00625	-62.9	1.1	-4.4	31.9	27.5	0.6	91.5
Up ⁽²⁾	806.00625	-59.9	1.1	-4.4	31.9	27.5	0.6	88.5
Up ⁽¹⁾	811.0	-62.1	1.1	-4.5	31.9	27.4	0.5	90.6
Up ⁽²⁾	811.0	-59.1	1.1	-4.5	31.9	27.4	0.5	87.6
Up ⁽¹⁾	815.99375	-59.8	1.1	-5.5	31.9	26.4	0.4	87.3
Up ⁽²⁾	815.99375	-56.8	1.1	-5.5	31.9	26.4	0.4	84.3
2. P25 Phase II(H-DQPSK)								
Up ⁽¹⁾	806.00625	-62.7	1.1	-4.7	31.9	27.2	0.5	91.0
Up ⁽²⁾	806.00625	-59.7	1.1	-4.7	31.9	27.2	0.5	88.0
Up ⁽¹⁾	811.0	-62.0	1.1	-4.9	31.9	27.0	0.5	90.1
Up ⁽²⁾	811.0	-59.0	1.1	-4.9	31.9	27.0	0.5	87.1
Up ⁽¹⁾	815.99375	-60.0	1.1	-6.1	31.9	25.8	0.4	86.9
Up ⁽²⁾	815.99375	-57.0	1.1	-6.1	31.9	25.8	0.4	83.9
3. DMR								
Up ⁽¹⁾	806.00625	-62.9	1.1	-4.1	31.9	27.8	0.6	91.8
Up ⁽²⁾	806.00625	-59.9	1.1	-4.1	31.9	27.8	0.6	88.8
Up ⁽¹⁾	811.0	-62.1	1.1	-4.1	31.9	27.8	0.6	91.0
Up ⁽²⁾	811.0	-59.1	1.1	-4.1	31.9	27.8	0.6	88.0
Up ⁽¹⁾	815.99375	-60.1	1.1	-5.5	31.9	26.4	0.4	87.6
Up ⁽²⁾	815.99375	-57.1	1.1	-5.5	31.9	26.4	0.4	84.6
4. Analog FM mode								

Up ⁽¹⁾	806.0125	-63.1	1.1	-3.9	31.9	28.0	0.6	92.2
Up ⁽²⁾	806.0125	-60.1	1.1	-3.9	31.9	28.0	0.6	89.2
Up ⁽¹⁾	811.0	-62.3	1.1	-3.9	31.9	28.0	0.6	91.4
Up ⁽²⁾	811.0	-59.3	1.1	-3.9	31.9	28.0	0.6	88.4
Up ⁽¹⁾	815.9875	-60.3	1.1	-5.3	31.9	26.6	0.5	88.0
Up ⁽²⁾	815.9875	-57.3	1.1	-5.3	31.9	26.6	0.5	85.0
5. Tetra								
Up ⁽¹⁾	806.0125	-63.0	1.1	-3.9	31.9	28.0	0.6	92.1
Up ⁽²⁾	806.0125	-60.0	1.1	-3.9	31.9	28.0	0.6	89.1
Up ⁽¹⁾	811.0	-62.3	1.1	-3.9	31.9	28.0	0.6	91.4
Up ⁽²⁾	811.0	-59.3	1.1	-3.9	31.9	28.0	0.6	88.4
Up ⁽¹⁾	815.9875	-60.3	1.1	-5.3	31.9	26.6	0.5	88.0
Up ⁽²⁾	815.9875	-57.3	1.1	-5.3	31.9	26.6	0.5	85.0

NOTE: ⁽¹⁾ Level is 0.5 dB below AGC threshold; ⁽²⁾ Level is 3dB above AGC threshold.

----- The following blanks -----

11.6.4.2. ERP Calculations

11.6.4.2.1. 700MHz Band

11.6.4.2.1.1. Downlink

Test link	Frequency (MHz)	EUT Max. output power (dBm)	Max. Ant Gain(dBi)	ERP (W)	ERP Limit (W)	AGC Mode
1. P25 Phase I(C4FM)						
Down	769.00625	31.2	4.0	3.3	5.0	-0.5dB Below
Down	769.00625	31.2	4.0	3.3	5.0	+3.0dB above
Down	772.0	32.6	4.0	4.6	5.0	-0.5dB Below
Down	772.0	32.6	4.0	4.6	5.0	+3.0dB above
Down	774.99375	30.8	4.0	3.0	5.0	-0.5dB Below
Down	774.99375	30.8	4.0	3.0	5.0	+3.0dB above
2. P25 Phase II(H-DQPSK)						
Down	769.00625	31.2	4.0	3.3	5.0	-0.5dB Below
Down	769.00625	31.2	4.0	3.3	5.0	+3.0dB above
Down	772.0	32.4	4.0	4.4	5.0	-0.5dB Below
Down	772.0	32.4	4.0	4.4	5.0	+3.0dB above
Down	774.99375	30.4	4.0	2.8	5.0	-0.5dB Below
Down	774.99375	30.4	4.0	2.8	5.0	+3.0dB above
3. DMR						
Down	769.00625	31.0	4.0	3.2	5.0	-0.5dB Below
Down	769.00625	31.0	4.0	3.2	5.0	+3.0dB above
Down	772.0	32.4	4.0	4.4	5.0	-0.5dB Below
Down	772.0	32.4	4.0	4.4	5.0	+3.0dB above
Down	774.99375	30.5	4.0	2.8	5.0	-0.5dB Below
Down	774.99375	30.5	4.0	2.8	5.0	+3.0dB above
4. Analog FM						
Down	769.0125	31.2	4.0	3.3	5.0	-0.5dB Below
Down	768.0125	31.2	4.0	3.3	5.0	+3.0dB above
Down	772.0	32.6	4.0	4.6	5.0	-0.5dB Below
Down	772.0	32.6	4.0	4.6	5.0	+3.0dB above
Down	774.9875	30.4	4.0	2.8	5.0	-0.5dB Below
Down	774.9875	30.4	4.0	2.8	5.0	+3.0dB above

5. Tetra						
Down	769.0125	31.2	4.0	3.3	5.0	-0.5dB Below
Down	768.0125	31.2	4.0	3.3	5.0	+3.0dB above
Down	772.0	32.6	4.0	4.6	5.0	-0.5dB Below
Down	772.0	32.6	4.0	4.6	5.0	+3.0dB above
Down	774.9875	30.7	4.0	3.0	5.0	-0.5dB Below
Down	774.9875	30.7	4.0	3.0	5.0	+3.0dB above

11.6.4.2.1.2. Uplink

Test link	Frequency (MHz)	EUT Max. output power (dBm)	Max. Ant Gain(dBi)	ERP (W)	ERP Limit (W)	AGC Mode
1. P25 Phase I(C4FM)						
Up	799.00625	25.9	9.0	3.1	5.0	-0.5dB Below
Up	799.00625	25.9	9.0	3.1	5.0	+3.0dB above
Up	802.0	27.5	9.0	4.5	5.0	-0.5dB Below
Up	802.0	27.5	9.0	4.5	5.0	+3.0dB above
Up	804.99375	27.5	9.0	4.5	5.0	-0.5dB Below
Up	804.99375	27.5	9.0	4.5	5.0	+3.0dB above
2. P25 Phase II(H-DQPSK)						
Up	799.00625	25.7	9.0	3.0	5.0	-0.5dB Below
Up	799.00625	25.7	9.0	3.0	5.0	+3.0dB above
Up	802.0	27.6	9.0	4.6	5.0	-0.5dB Below
Up	802.0	27.6	9.0	4.6	5.0	+3.0dB above
Up	804.99375	27.8	9.0	4.8	5.0	-0.5dB Below
Up	804.99375	27.8	9.0	4.8	5.0	+3.0dB above
3. DMR						
Up	799.00625	26.1	9.0	3.2	5.0	-0.5dB Below
Up	799.00625	26.1	9.0	3.2	5.0	+3.0dB above
Up	802.0	27.7	9.0	4.7	5.0	-0.5dB Below
Up	802.0	27.7	9.0	4.7	5.0	+3.0dB above
Up	804.99375	28.0	9.0	5.0	5.0	-0.5dB Below
Up	804.99375	28.0	9.0	5.0	5.0	+3.0dB above
4. Analog FM mode						

Up	799.0125	26.3	9.0	3.4	5.0	-0.5dB Below
Up	799.0125	26.3	9.0	3.4	5.0	+3.0dB above
Up	802.0	27.9	9.0	4.9	5.0	-0.5dB Below
Up	802.0	27.9	9.0	4.9	5.0	+3.0dB above
Up	804.9875	28.0	9.0	5.0	5.0	-0.5dB Below
Up	804.9875	28.0	9.0	5.0	5.0	+3.0dB above
5. Tetra						
Up	799.0125	26.7	9.0	3.7	5.0	-0.5dB Below
Up	799.0125	26.7	9.0	3.7	5.0	+3.0dB above
Up	802.0	28.0	9.0	5.0	5.0	-0.5dB Below
Up	802.0	28.0	9.0	5.0	5.0	+3.0dB above
Up	804.9875	28.0	9.0	5.0	5.0	-0.5dB Below
Up	804.9875	28.0	9.0	5.0	5.0	+3.0dB above

----- The following blanks -----

11.6.4.2.2. 800MHz Band

11.6.4.2.2.1. Downlink

Test link	Frequency (MHz)	EUT Max. output power (dBm)	Max. Ant Gain(dBi)	ERP (W)	ERP Limit (W)	AGC Mode
1. P25 Phase I(C4FM)						
Down	851.00625	29.4	4.0	2.2	5.0	-0.5dB Below
Down	851.00625	29.4	4.0	2.2	5.0	+3.0dB above
Down	856.0	32.9	4.0	4.9	5.0	-0.5dB Below
Down	856.0	32.9	4.0	4.9	5.0	+3.0dB above
Down	860.99375	31.6	4.0	3.6	5.0	-0.5dB Below
Down	860.99375	31.6	4.0	3.6	5.0	+3.0dB above
2. P25 Phase II(H-DQPSK)						
Down	851.00625	29.2	4.0	2.1	5.0	-0.5dB Below
Down	851.00625	29.2	4.0	2.1	5.0	+3.0dB above
Down	856.0	32.8	4.0	4.8	5.0	-0.5dB Below
Down	856.0	32.8	4.0	4.8	5.0	+3.0dB above
Down	860.99375	31.4	4.0	3.5	5.0	-0.5dB Below
Down	860.99375	31.4	4.0	3.5	5.0	+3.0dB above
3. DMR						
Down	851.00625	29.3	4.0	2.1	5.0	-0.5dB Below
Down	851.00625	29.3	4.0	2.1	5.0	+3.0dB above
Down	856.0	32.7	4.0	4.7	5.0	-0.5dB Below
Down	856.0	32.7	4.0	4.7	5.0	+3.0dB above
Down	860.99375	31.5	4.0	3.5	5.0	-0.5dB Below
Down	860.99375	31.5	4.0	3.5	5.0	+3.0dB above
4. Analog FM						
Down	851.0125	29.2	4.0	2.1	5.0	-0.5dB Below
Down	851.0125	29.2	4.0	2.1	5.0	+3.0dB above
Down	856.0	32.7	4.0	4.7	5.0	-0.5dB Below
Down	856.0	32.7	4.0	4.7	5.0	+3.0dB above
Down	860.9875	31.4	4.0	3.5	5.0	-0.5dB Below
Down	860.9875	31.4	4.0	3.5	5.0	+3.0dB above