

PX8RA-5700-D Operation Description

The RA-5700-D is Master Unit of Multi-band Distributed Antenna System RA-5700, which is an RF over fiber solution that can enhance a wireless network's coverage by extending cellular services from existing cell sites for both indoor and outdoor applications.

The Master Unit (MU) is modular designed up to support 3 independent inputs, for example 700MHz, 850MHz and 1900MHz. It is modular designed so that each unit can accommodate up to 3 independent bands.

On the DL, combined signals as 700MHz, 850MHz and 1900MHz from the BTSs converted into optical signals after amplification in the MU. Then the optical signals are transmitted to the Remote Unit (RU) via optical fiber.

On the UL, the optical signals from Remote Unit are converted into RF signals, and then transfer to BTS receiver via RF coupler.

Distributed Antenna System

RA-5700 1W/Per Band



Features

- Tri-band configuration supports three frequency bands in a single system. e.g., 700MHz+850MHz+1900Mhz
- Full operation bandwidth system supports multi-operator application, supports CDMA and LTE.
- Supports both Indoor and outdoor DAS application with meeting the need of coverage and capacity expansion
- Supports all major modulations in mixed mode
- Comply with 3GPP & FCC
- Grow with the network, extendable from tri-band up to 6 bands.
- Easy setup with automated optical gain equalization over web GUI interface
- Alarm forward to NOC or standard EMS system through SNMP
- Output power control by software.
- Optical link auto gain control.
- Fully sealed RU, maintenance free electronics for harsh outdoor applications



Product Description

The RA-5700 Multi-band Distributed Antenna System is an RF over fiber solution that can enhance a wireless network's coverage by extending cellular services from existing cell sites for both indoor and outdoor applications. The system consists of the Master Unit (MU) and Remote Unit (RU). The MU is modular designed up to support 3 independent inputs, for example 700MHz, 850MHz and 1900MHz. Utilizing this modular design, the system can also be configured for a quad band & 2x2 MIMO configurations. Remote Unit is designed with a compact chassis for easy installation, it is modular designed so that each unit can accommodate up to 3 independent bands.

This solution is an effective point-to-multipoint distributed antenna system that provides effective coverage enhancement. The solution offers service providers an optimal solution for multiple applications from a single building to a campus, mega mall, sports arena to a large city center and beyond.

Functional Block Diagram

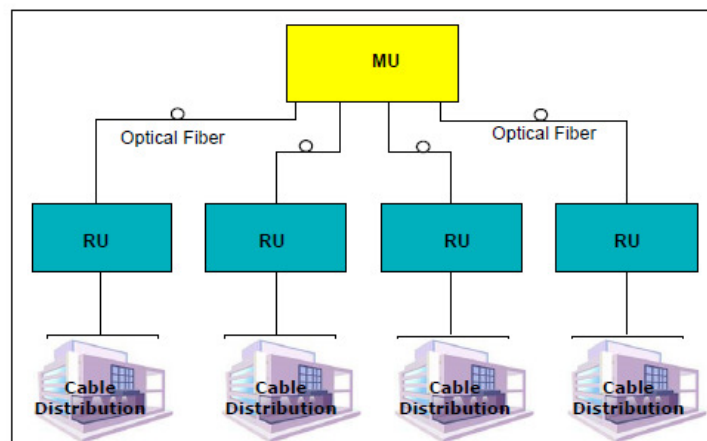

PX8RA-5700-D is master unit of RA-5700 system

The Uplink RF output power, gain, maximum input power and power supply are list in the following table.

System Specifications		
System		700MHz, 850MHz, 1900MHz
Optical Fiber		Single Mode
Optical Wavelength	nm	1310, 1550 + WDM
Optical Output Power	dBm	3 - 5
Optical Return Loss	dB	> 50
Max. Optical Loss	dB	5
Optical Automatic Gain Control	dB	5
Fiber Connectors		FC/APC

			700MHz	850MHz	1900MHz
Electrical Specifications					
Frequency Range	Uplink	MHz	698 - 716 or 777 - 787	824 - 849	1850 - 1915
	Downlink		728 - 746 or 746 - 756	869 - 894	1930 - 1995
Uplink Output Power		dBm	-20		
Maximum gain	Uplink	dB	30		
	Downlink		30		
ATT Adjustable Range(1dB step)	Master Unit	dB	0 - 30		
	Remote Unit		0 - 30		
Pass Band Ripple (p-p)		dB	≤ 4		
Out of carrier spurious emission			3GPP TS 36 106	3GPP TS 36 106/FCC	3GPP TS 36 106/FCC
Out of band spurious emission			/	FCC	FCC
Intermodulation			/	< -30dBc	/
			/	/	< -30dBc
Out of band rejection*	±1.5MHz		/	< -30dBc	/
	±2MHz		/	/	< -30dBc
Uplink Noise Figure at Maximum Gain		dB	≤ 10		
System Delay		μsec	≤ 6		
PAR		dB	10	8	8
VSWR			≤ 1.5		
EVM (LTE)		%	≤ 8%		
Absolute Maximum Input RF Power	Uplink	dBm	0		
	Downlink		25		
Mechanical Specifications					
Dimensions, H x W x D	Master Unit	in(mm)	19" x 17.2" x 5.2" (482.6 x 360 x 132)		
	Remote Unit		5" x 10" x 20"(127 x 254 x 508)		
Weight (approx.)	Master Unit	lb(kg)	26.5(12)		
	Remote Unit		43(19.5)		
Power Supply		VAC	85 - 264 / 47 - 63Hz		
Power Consumption (approx.)	Master Unit	W	50		
	Remote Unit		160		
RF Connectors	Master Unit		SMA - Female		
	Remote Unit		N - Female		
Operating Temperature	Master Unit	°C	0 to +40		
	Remote Unit		-30 to +50		
Operating Humidity	Master Unit	%	≤ 85		
	Remote Unit		≤ 95		
Ingress protection	Master Unit		IP30		
	Remote Unit		IP65		

Master Unit

