

(5) 1x EV-DO modulation

(5.1) Lower Edge

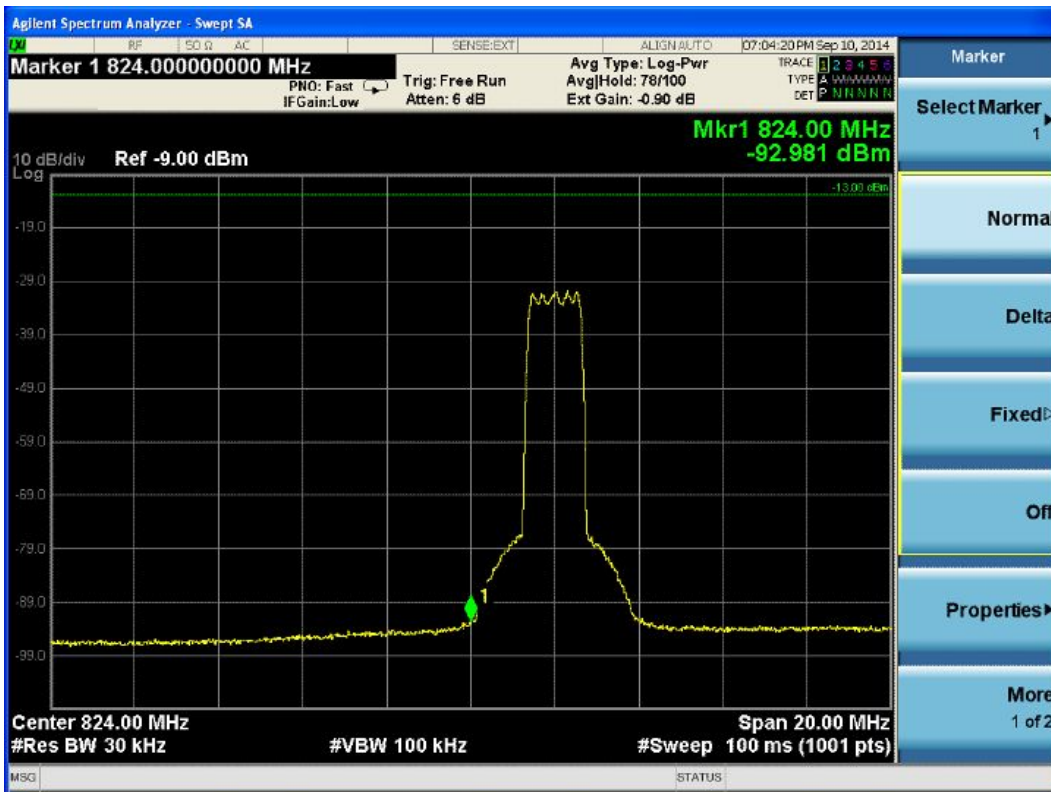

(5.2) Upper Edge

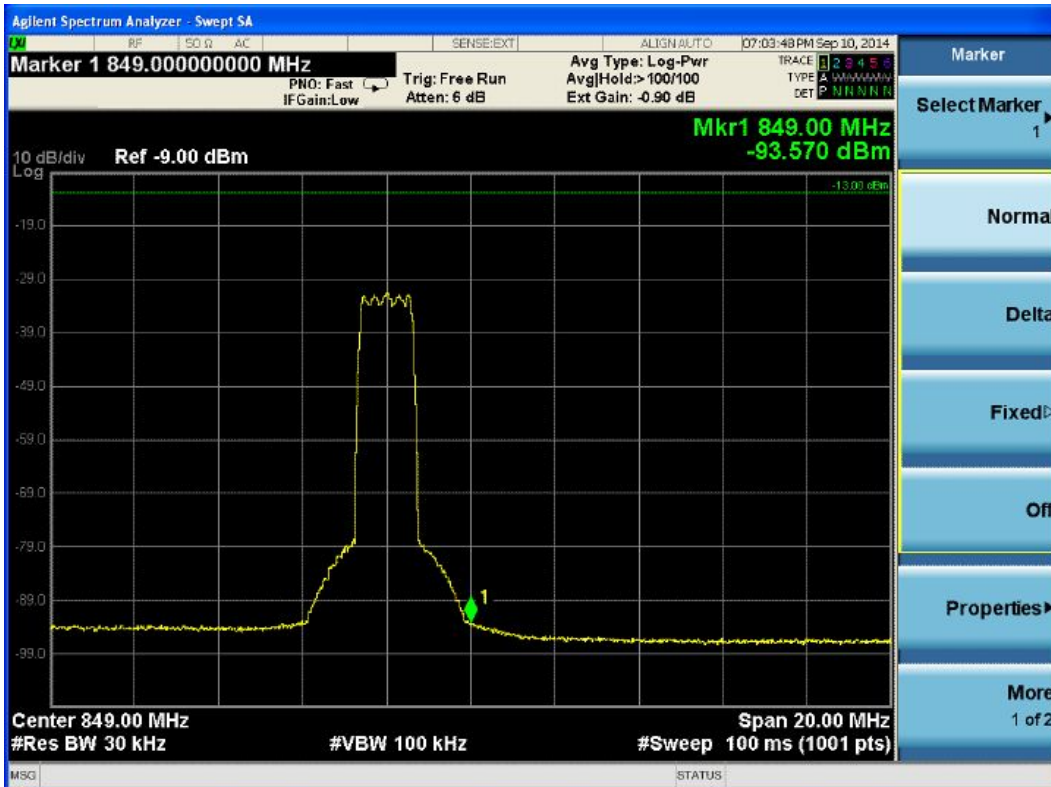

5.2.3.1.5 1900MHz Band

(1) LTE modulation

(1.1) Test for LTE 1.4MHz

(1.1.1) Lower Edge

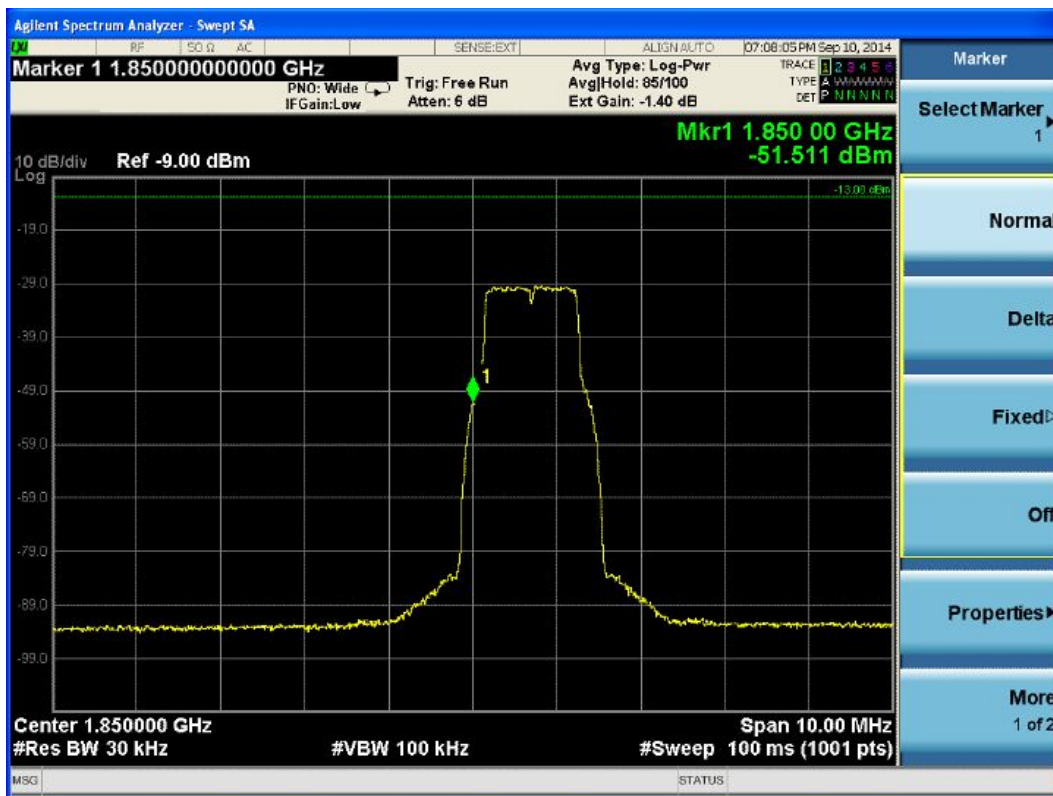

(1.1.2) Upper Edge

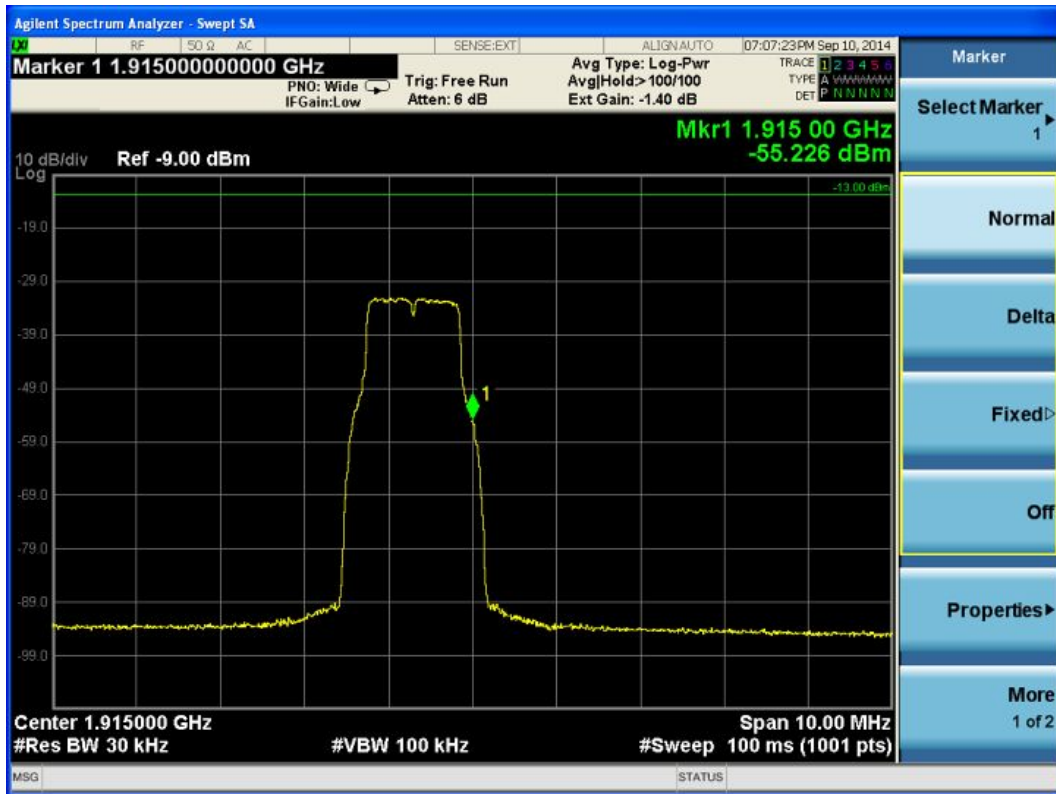

(1.2) Test for LTE 3MHz

(1.2.1) Lower Edge

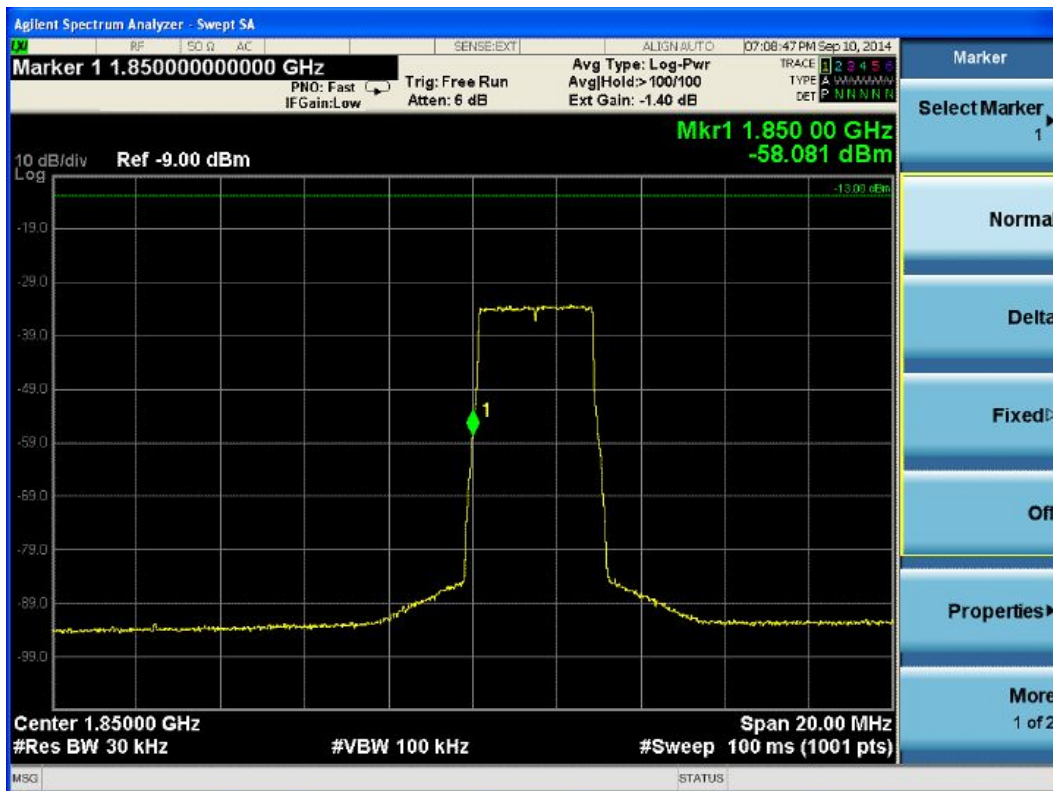

(1.2.2) Upper Edge

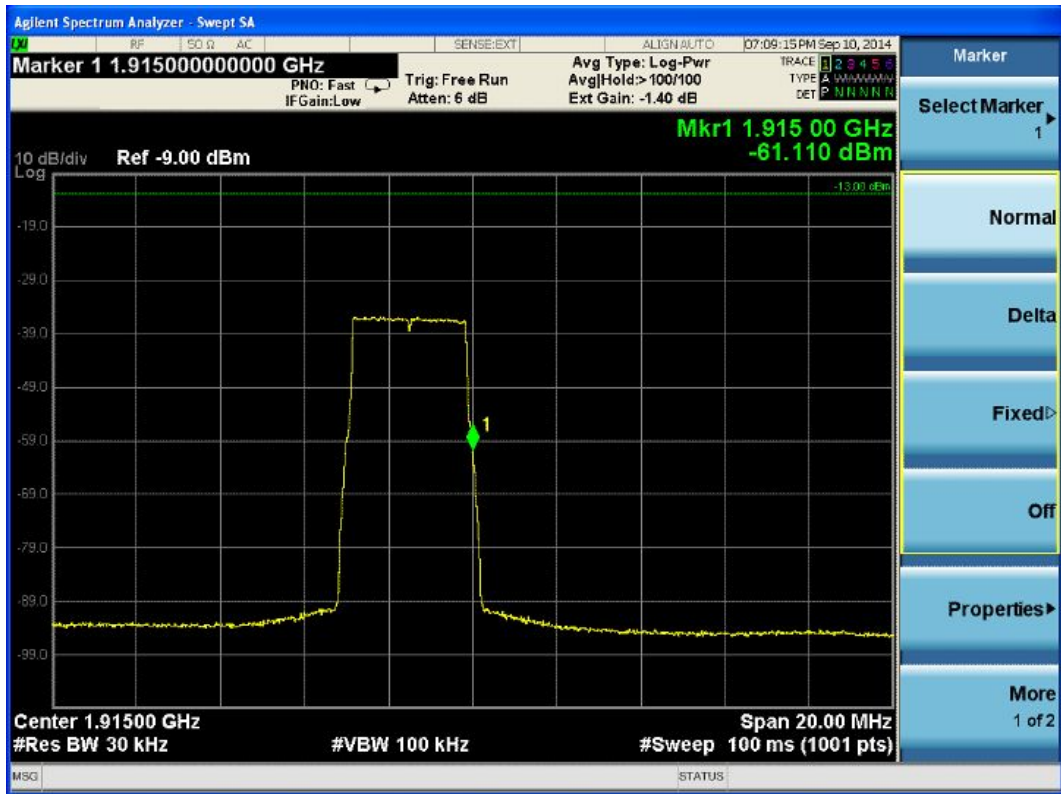

(1.3) Test for LTE 5MHz

(1.3.1) Lower Edge

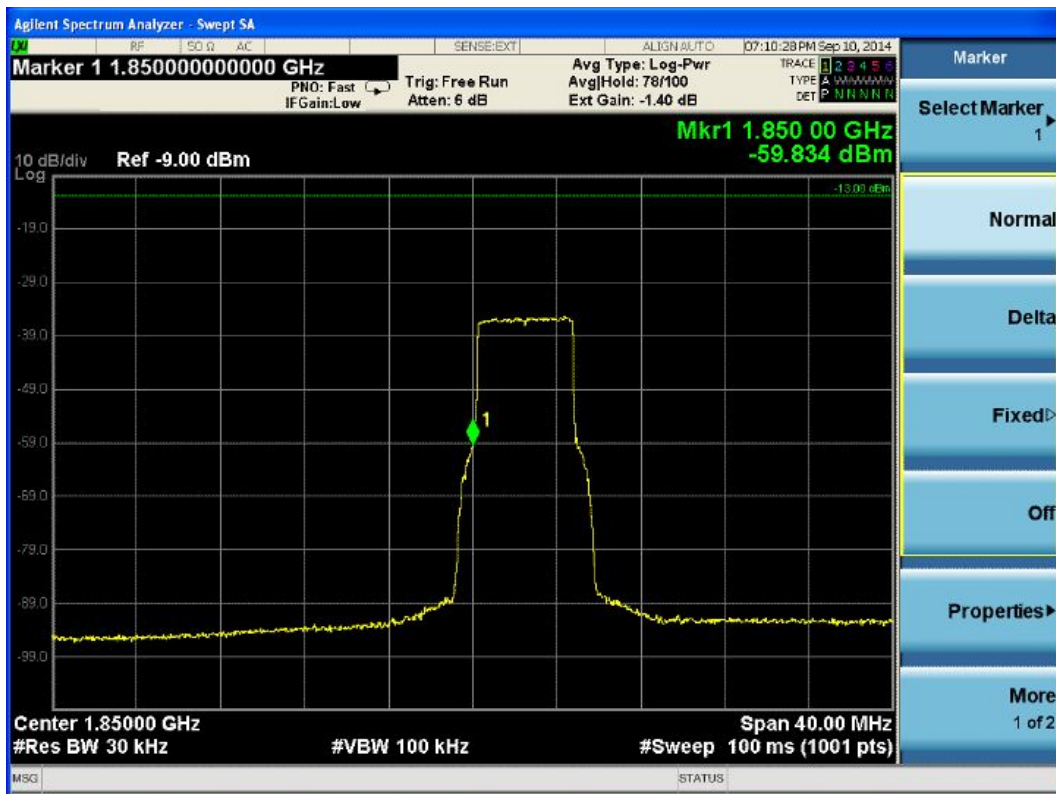

(1.3.2) Upper Edge

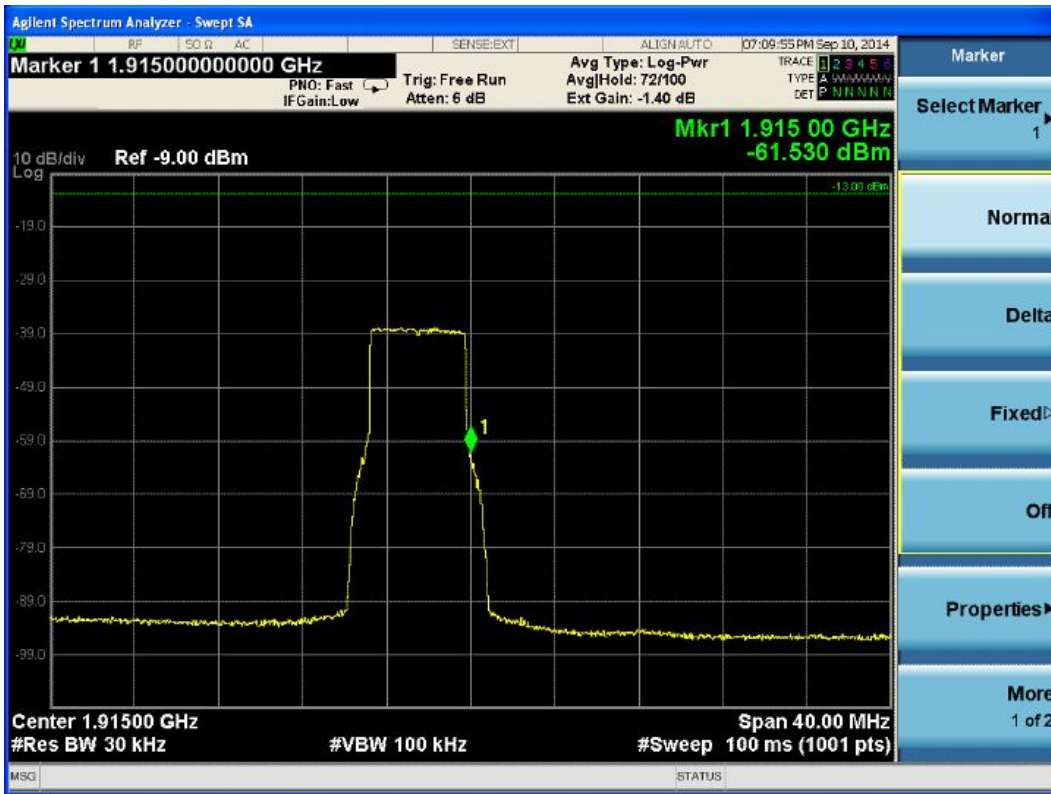

(1.4) Test for LTE 10 MHz

(1.4.1) Lower Edge

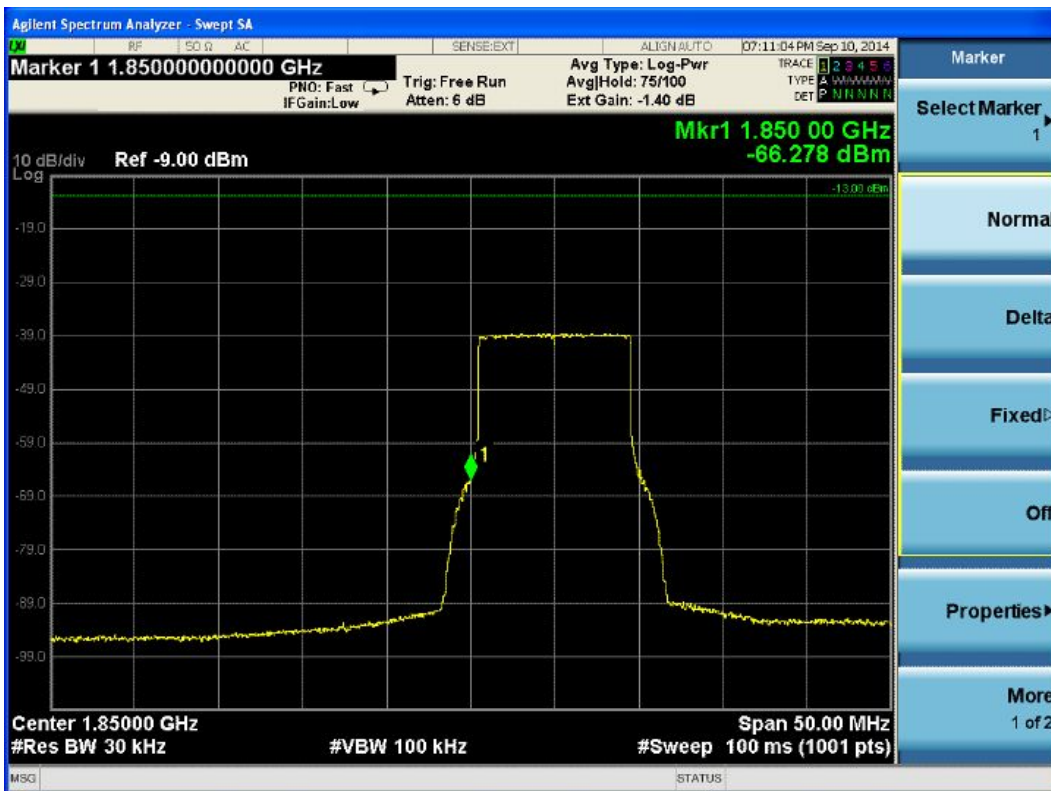

(1.4.2) Upper Edge

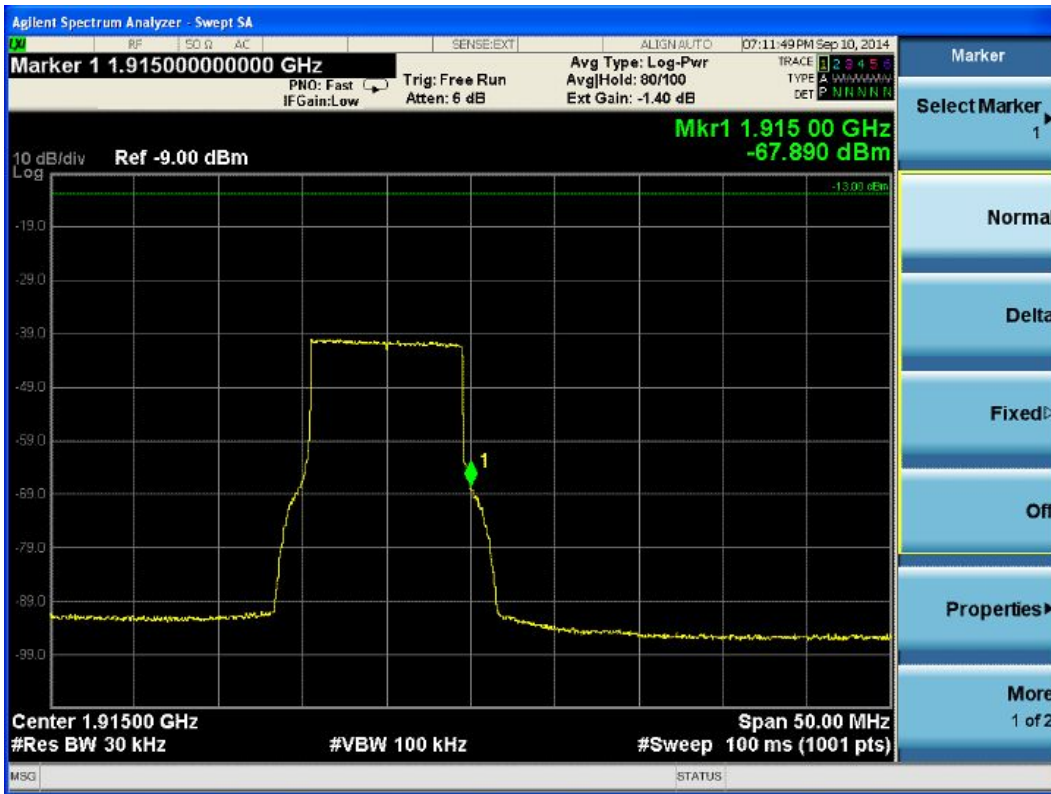

(1.5) Test for LTE 15 MHz

(1.5.1) Lower Edge



(1.5.2) Upper Edge



(1.6) Test for LTE 20 MHz

(1.6.1) Lower Edge

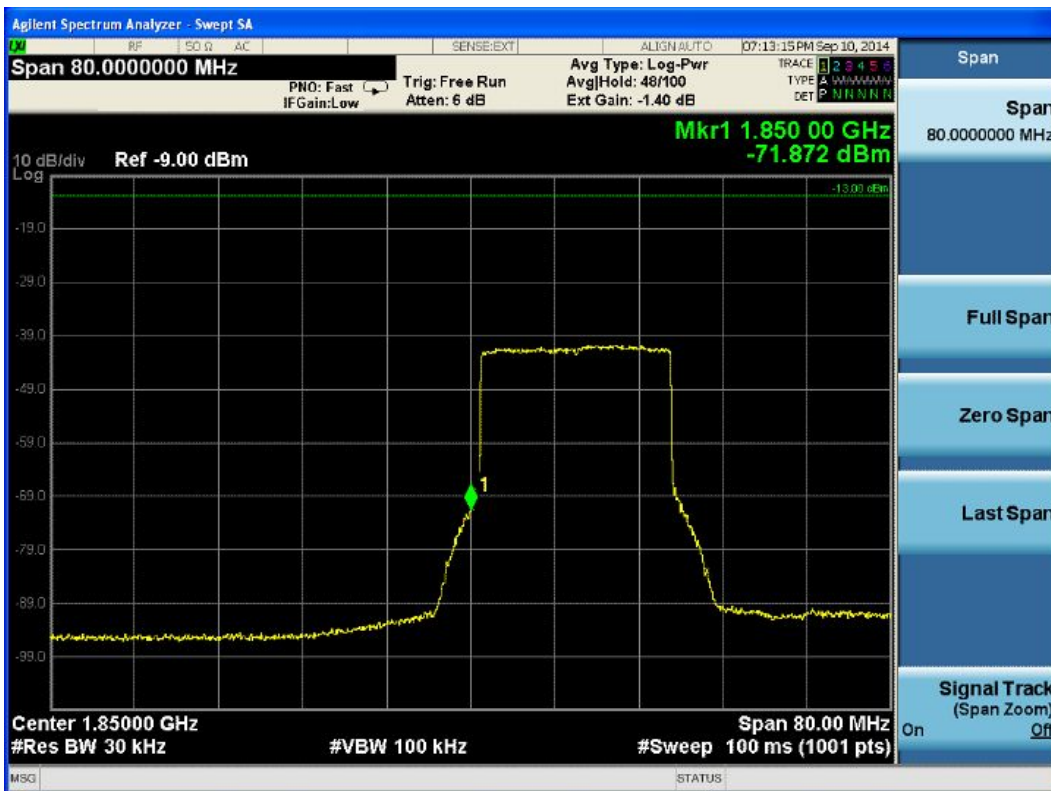

(1.6.2) Upper Edge

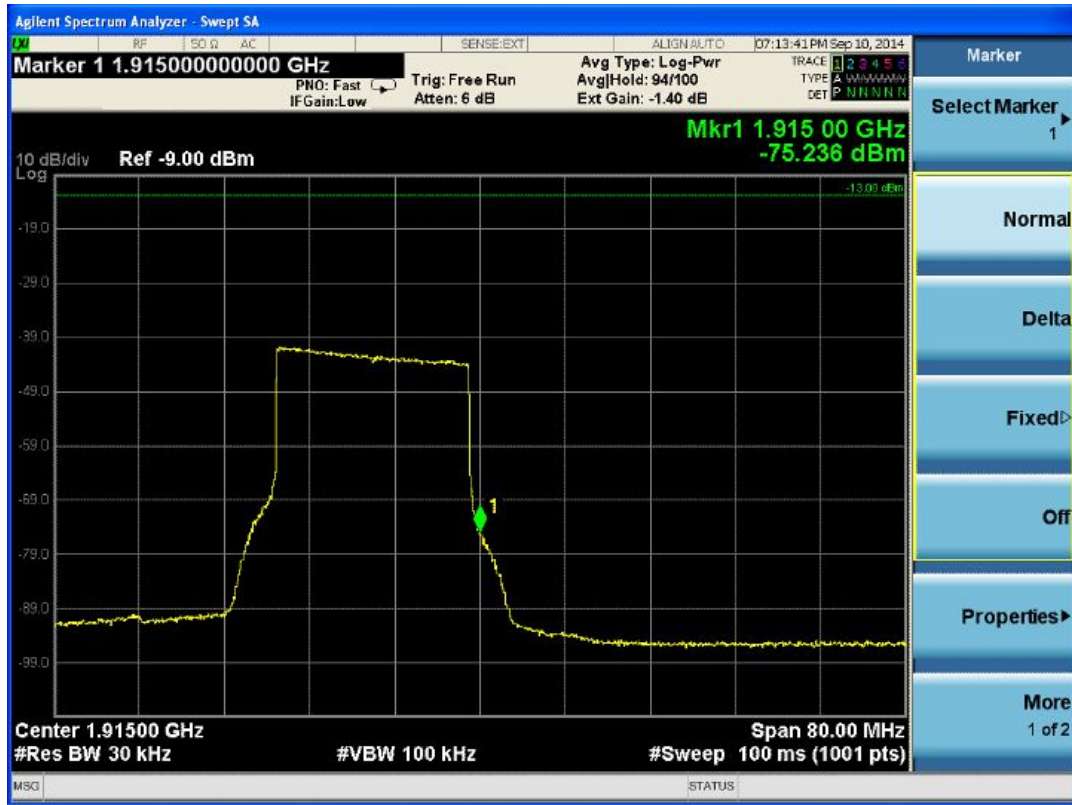

(2) GSM modulation

(2.1) Lower Edge

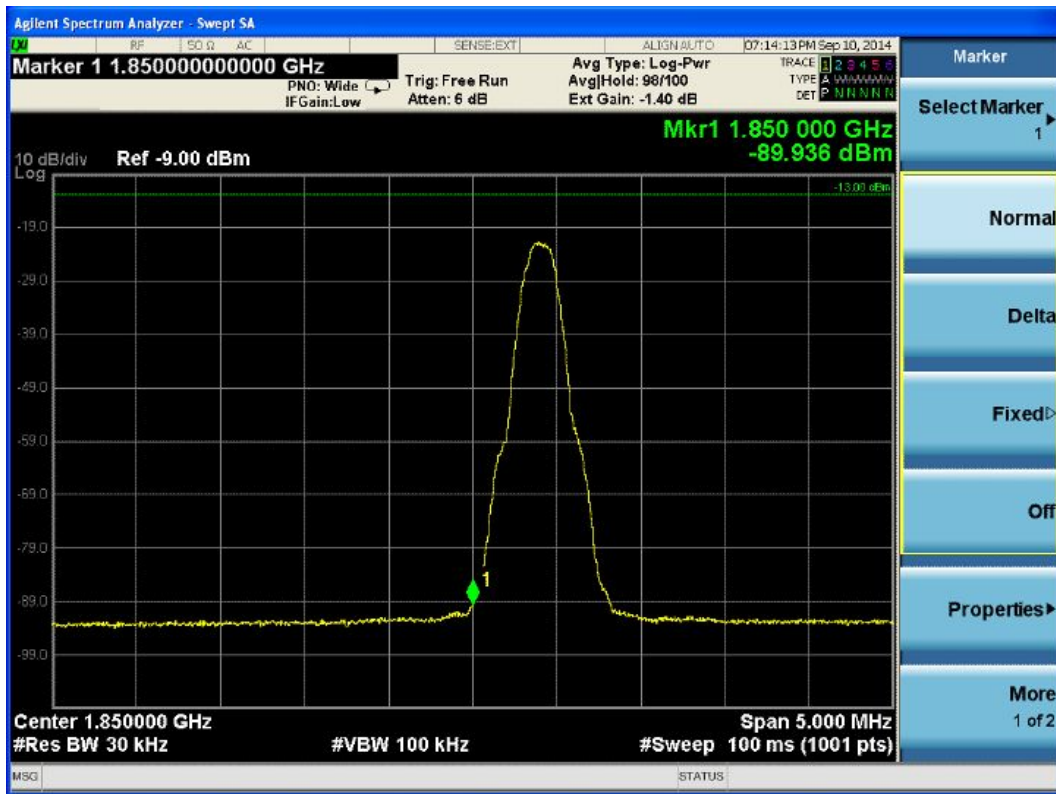

(2.2) Upper Edge

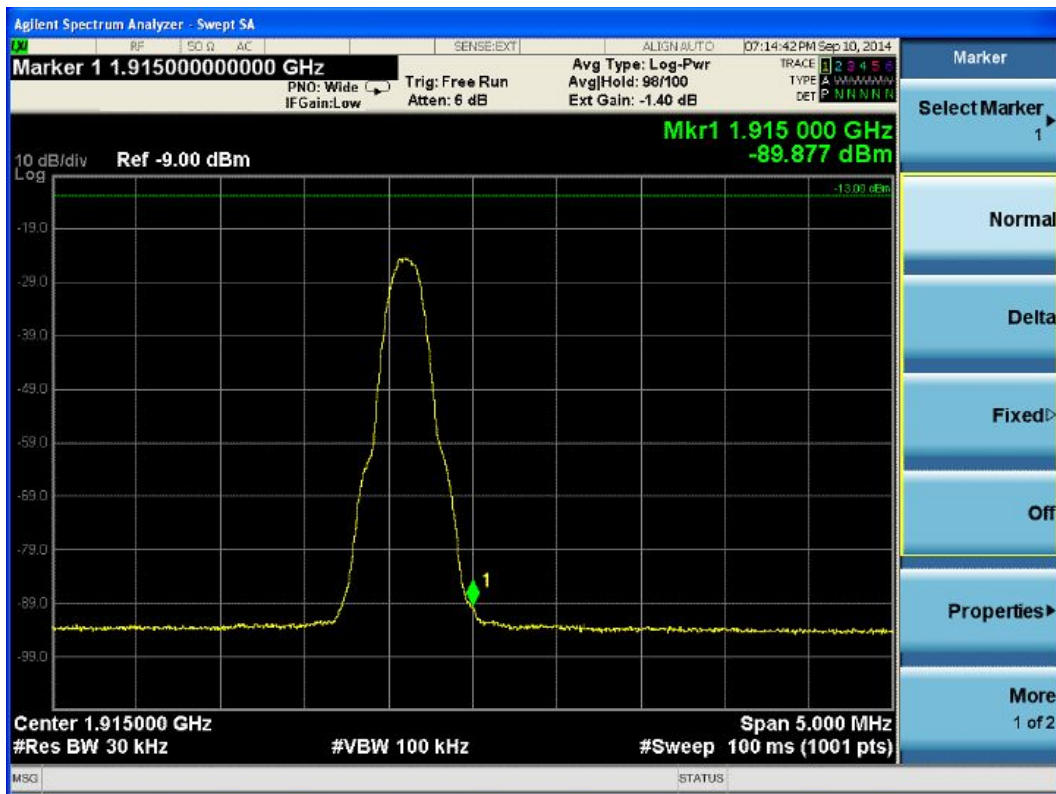

(3) CDMA modulation

(3.1) Lower Edge

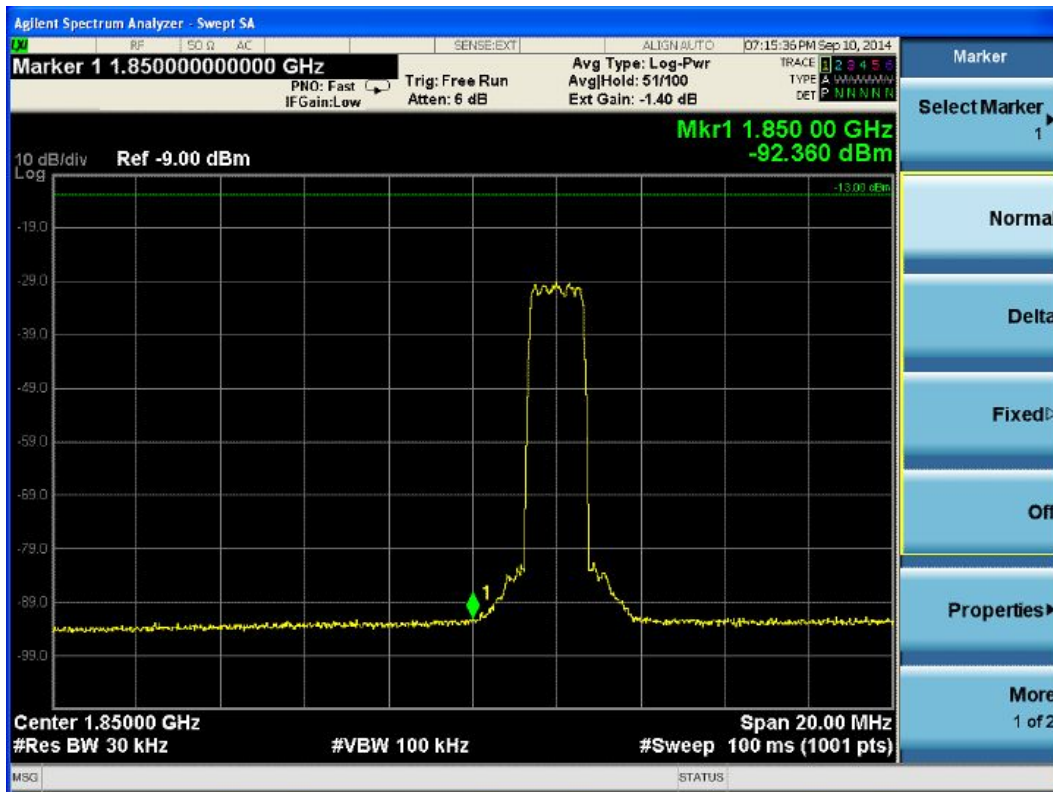

(3.2) Upper Edge

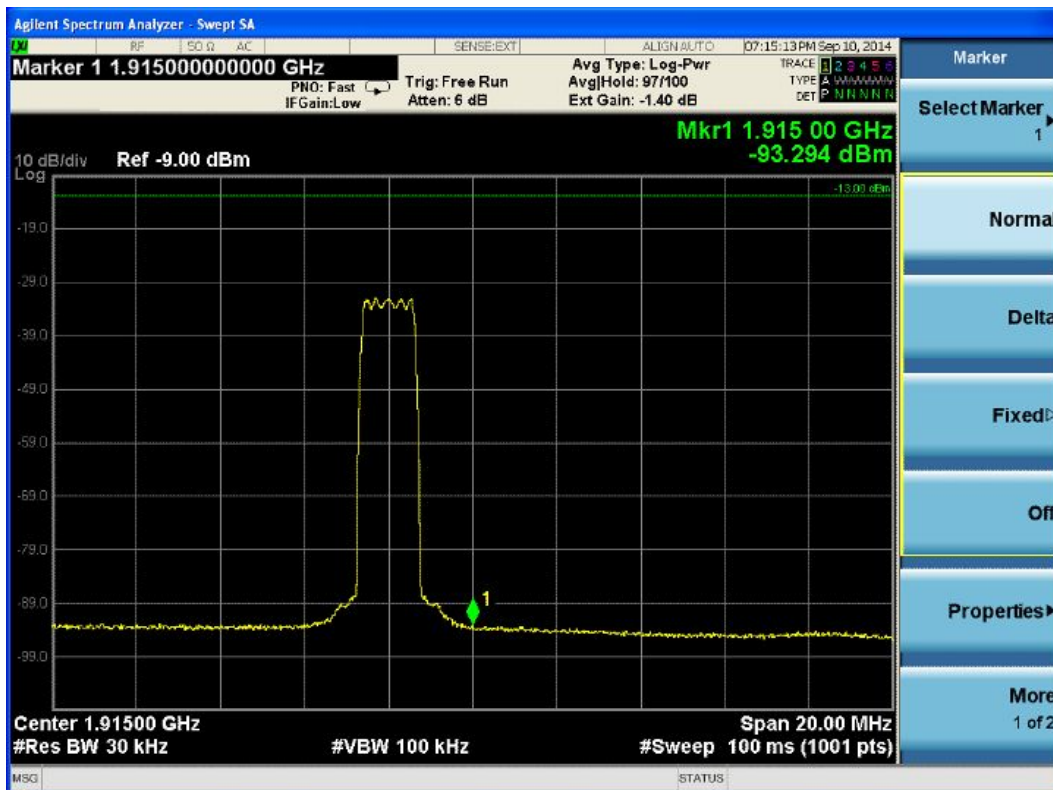

(4) WCDMA modulation

(4.1) Lower Edge

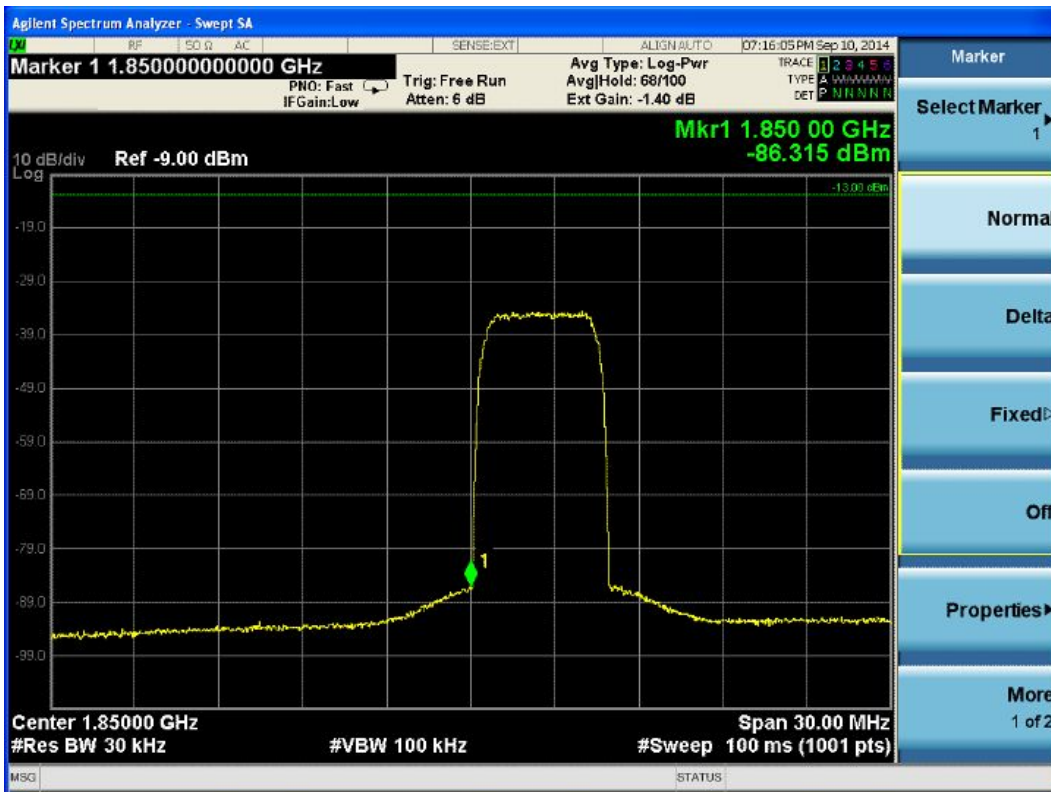

(4.2) Upper Edge

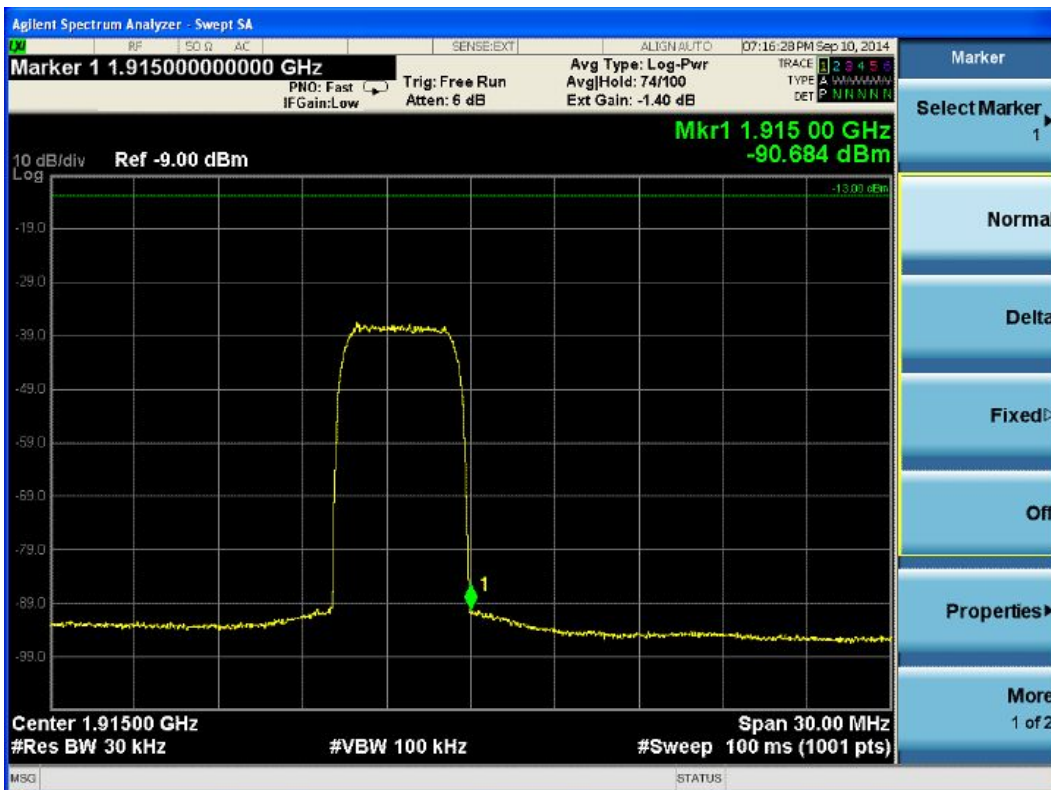

5.3.3.1.6 AWS-1 Band

(1) LTE modulation

(1.1) Test for LTE 1.4MHz

(1.1.1) Lower Edge

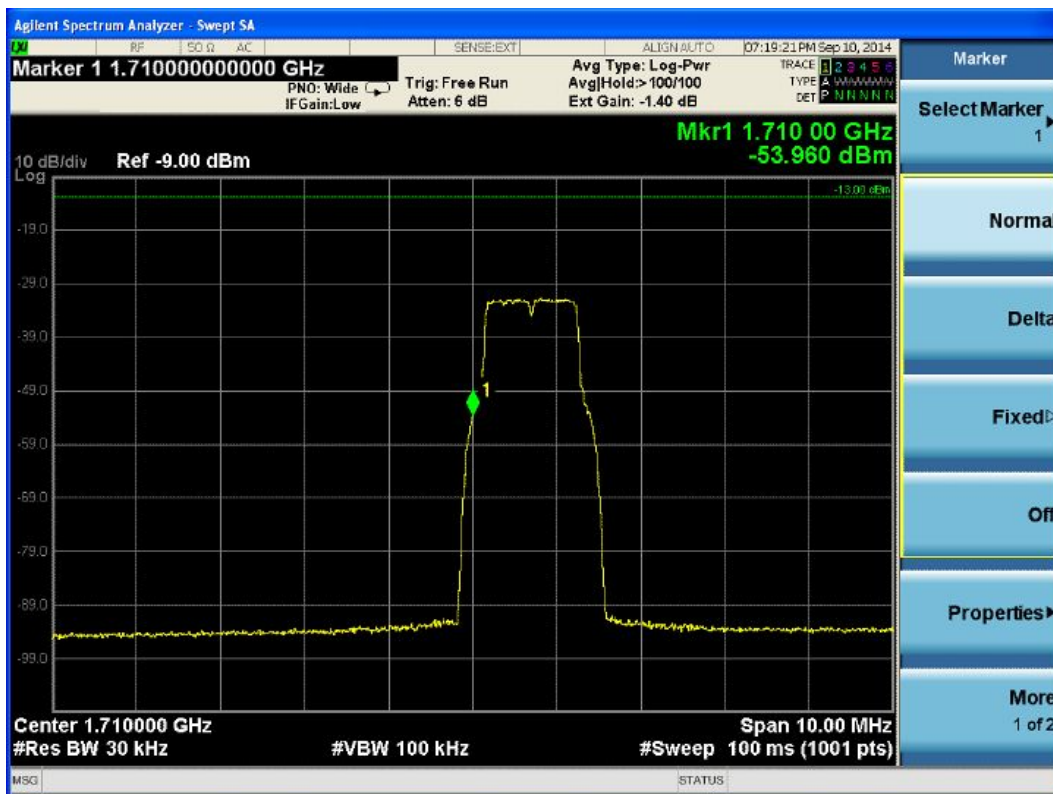

(1.1.2) Upper Edge

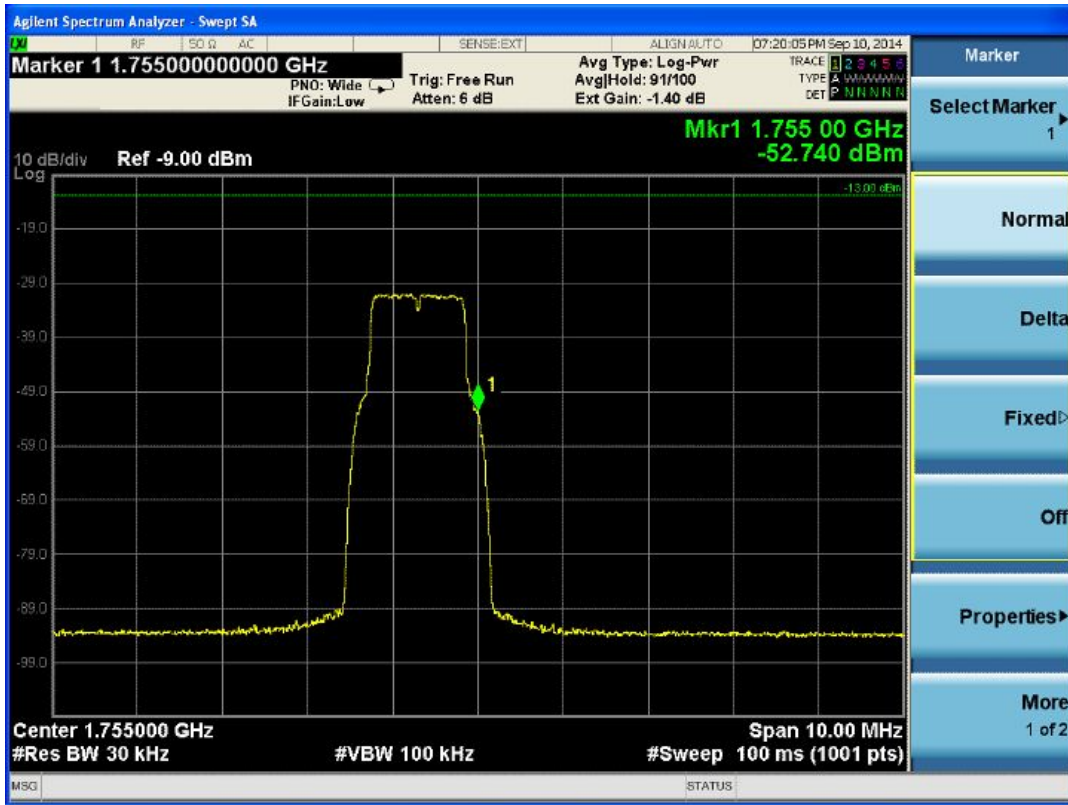

(1.2) Test for LTE 3MHz

(1.2.1) Lower Edge

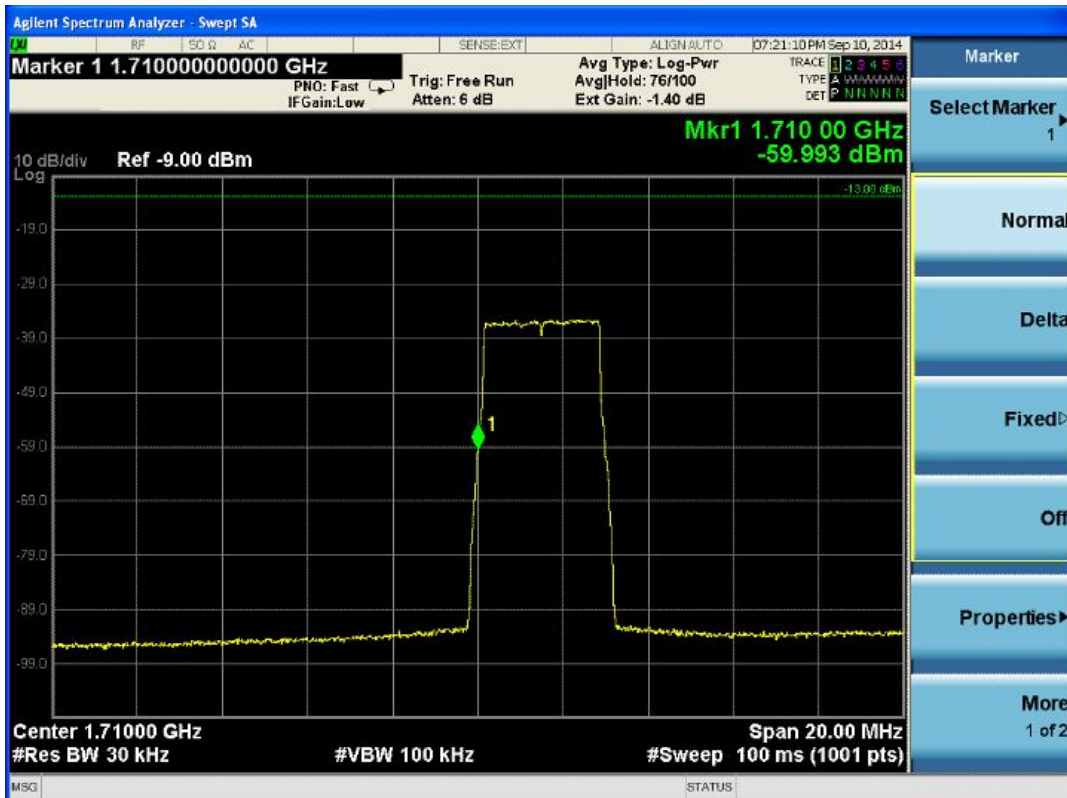

(1.2.2) Upper Edge

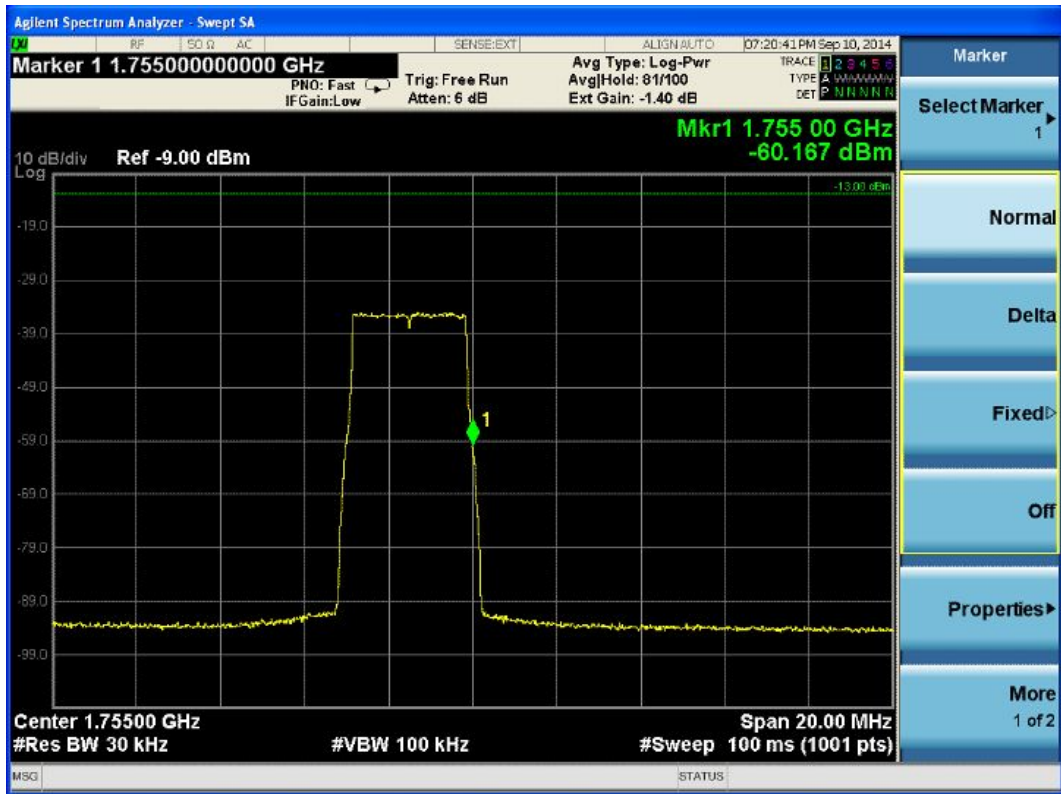

(1.3) Test for LTE 5MHz

(1.3.1) Lower Edge

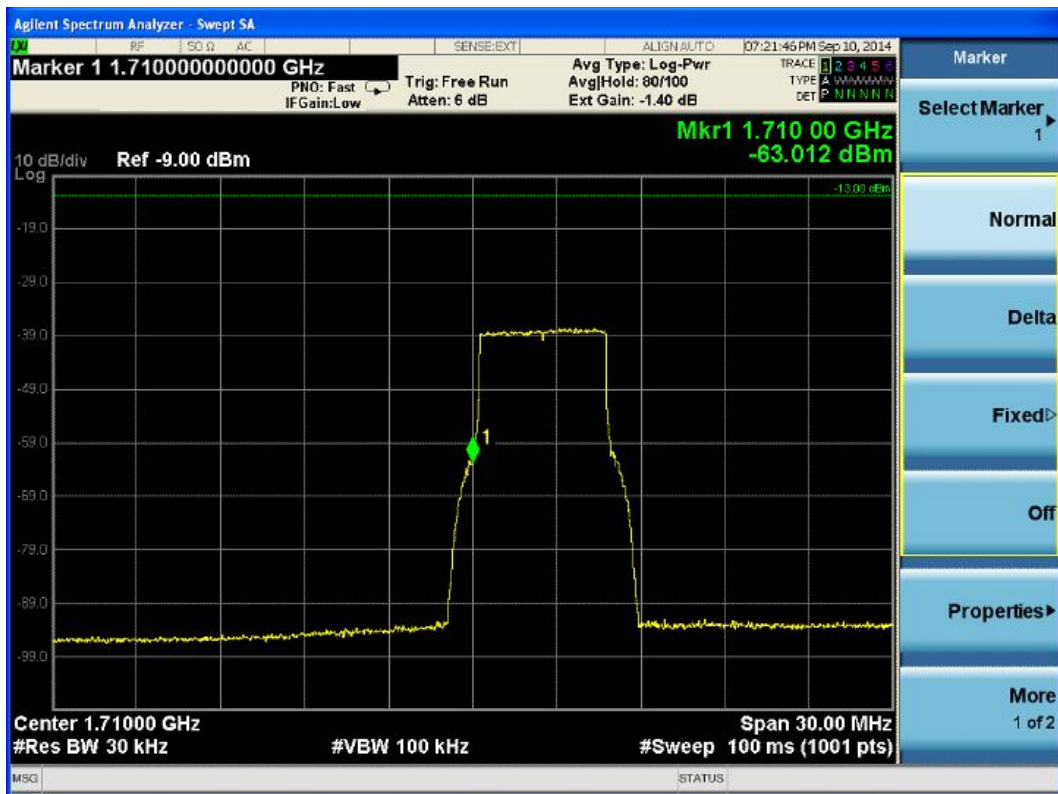

(1.3.2) Upper Edge

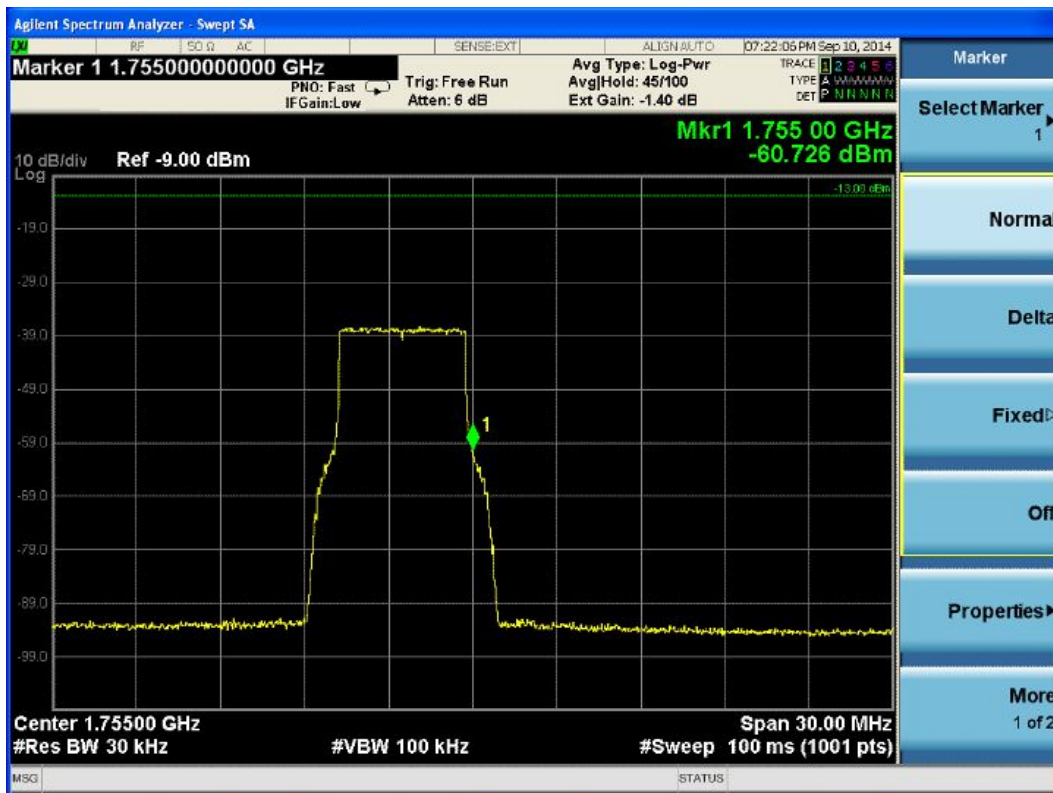

(1.4) Test for LTE 10MHz

(1.4.1) Lower Edge



(1.4.2) Upper Edge

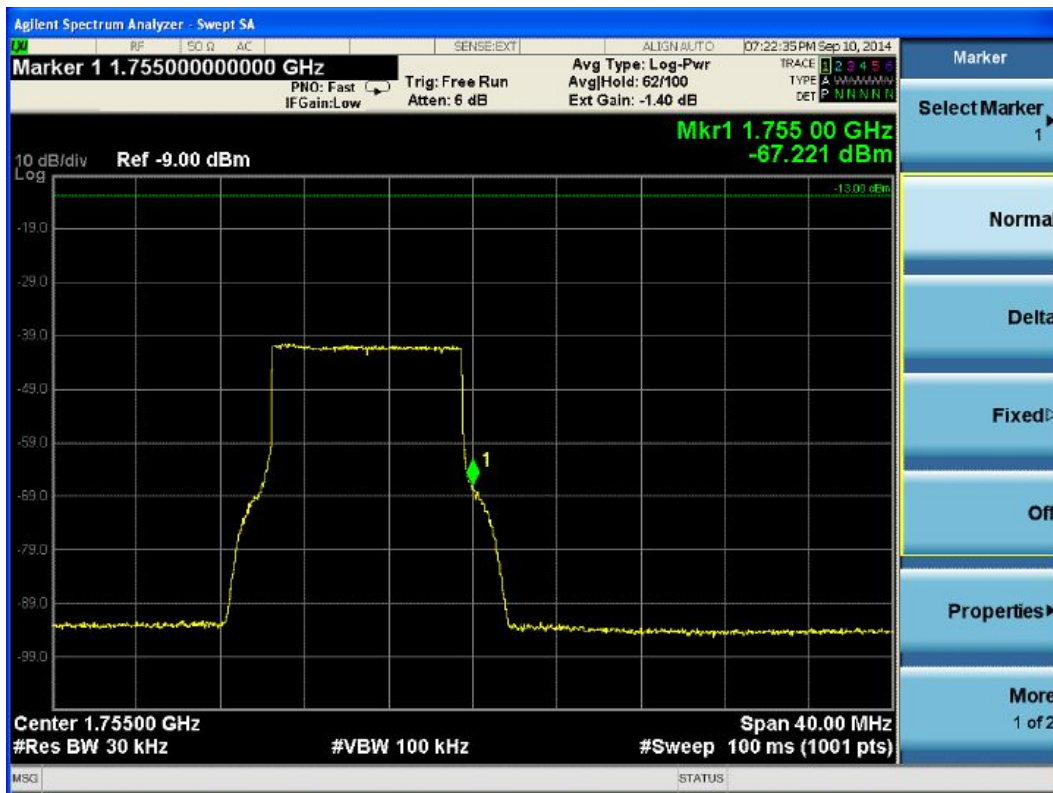

(1.5) Test for LTE 15MHz

(1.5.1) Lower Edge



(1.5.2) Upper Edge



(1.6) Test for LTE 20MHz

(1.6.1) Lower Edge

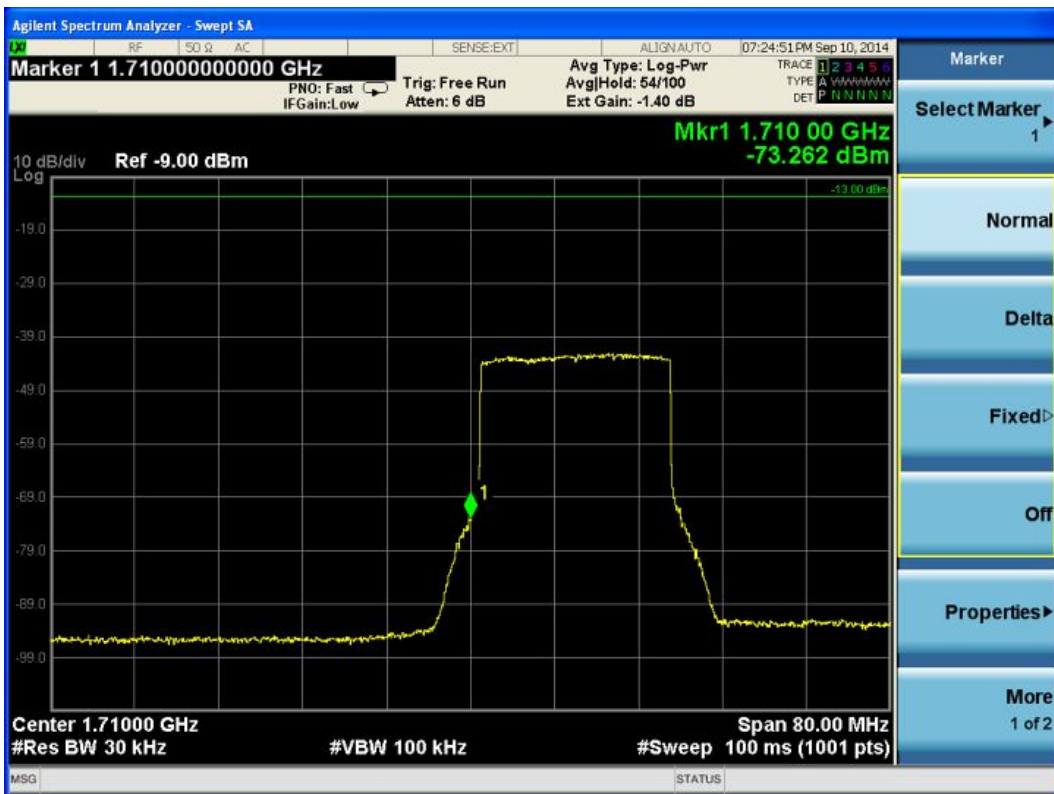

(1.6.2) Upper Edge

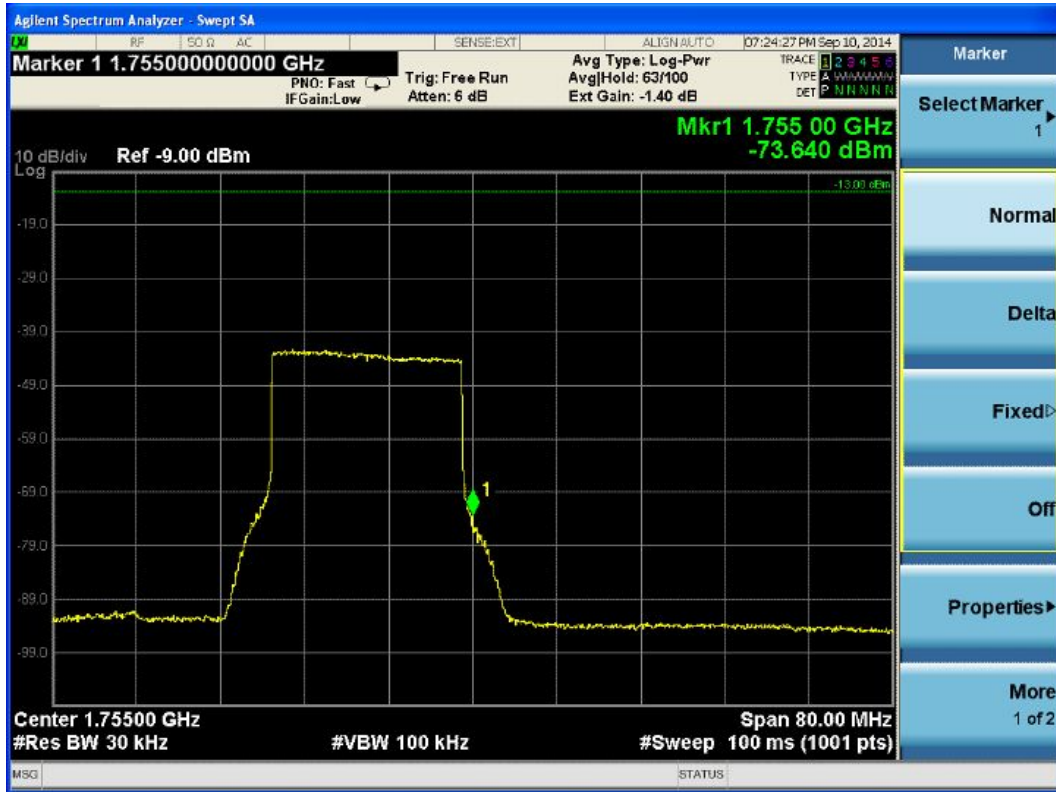

(2) CDMA modulation

(2.1) Lower Edge

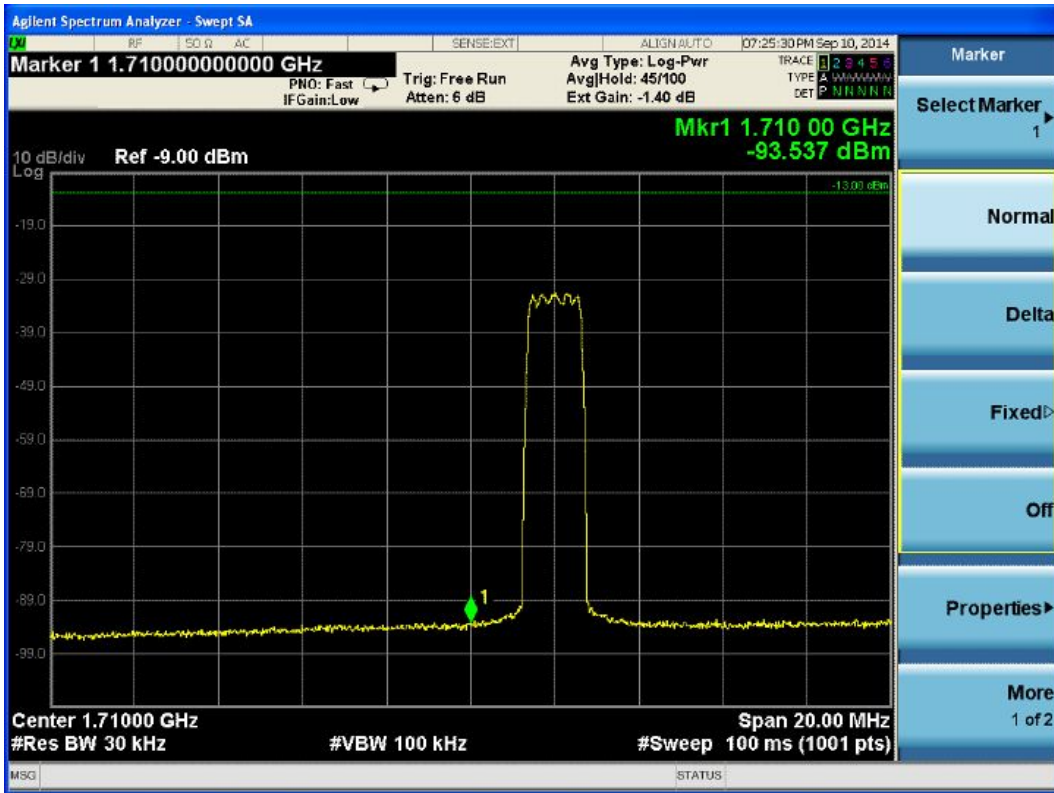

(2.2) Upper Edge

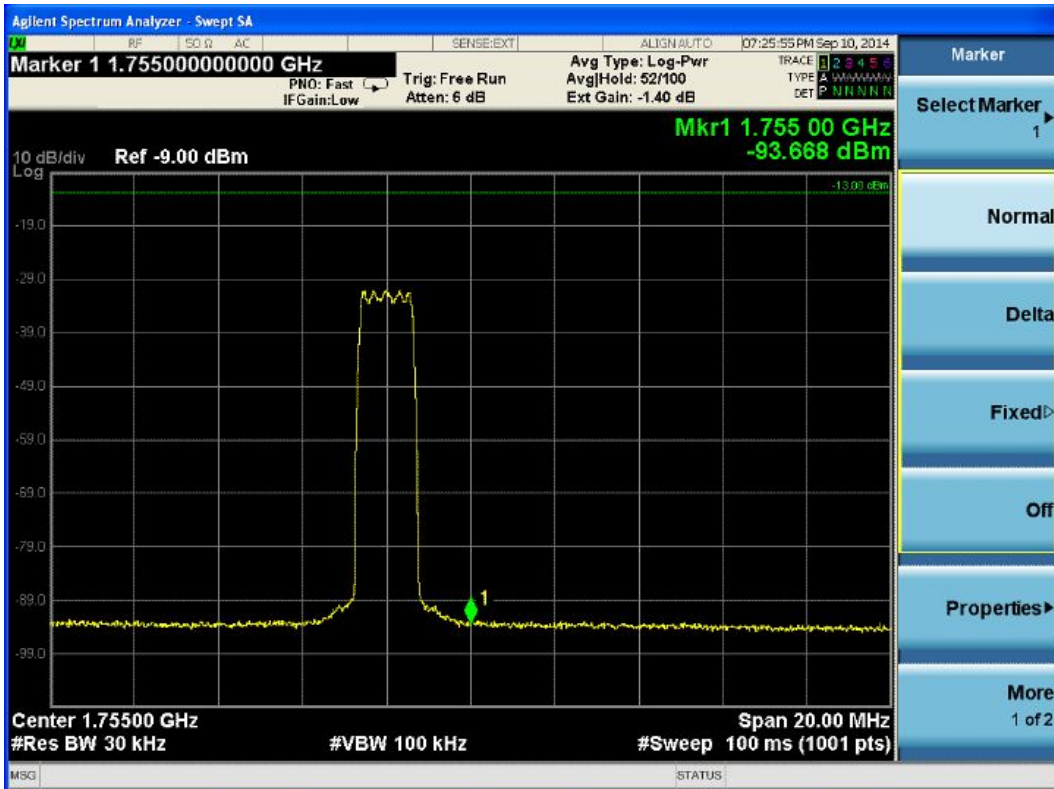

(3) WCDMA modulation

(3.1) Lower Edge

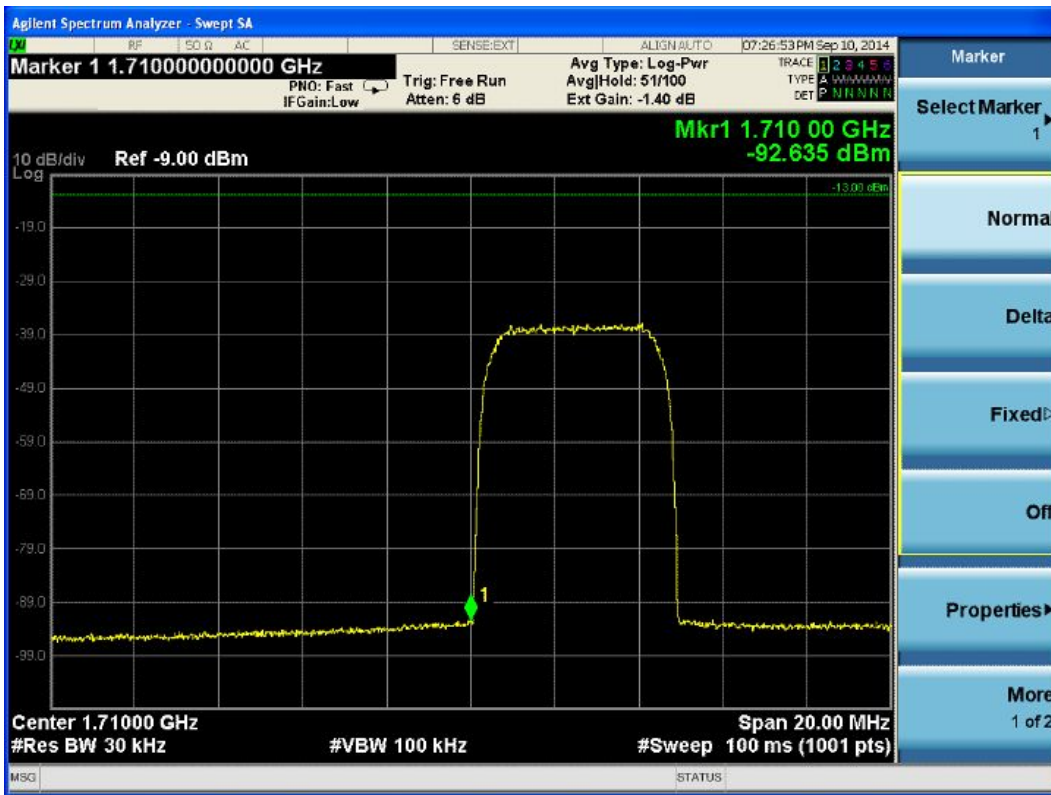

(3.2) Upper Edge

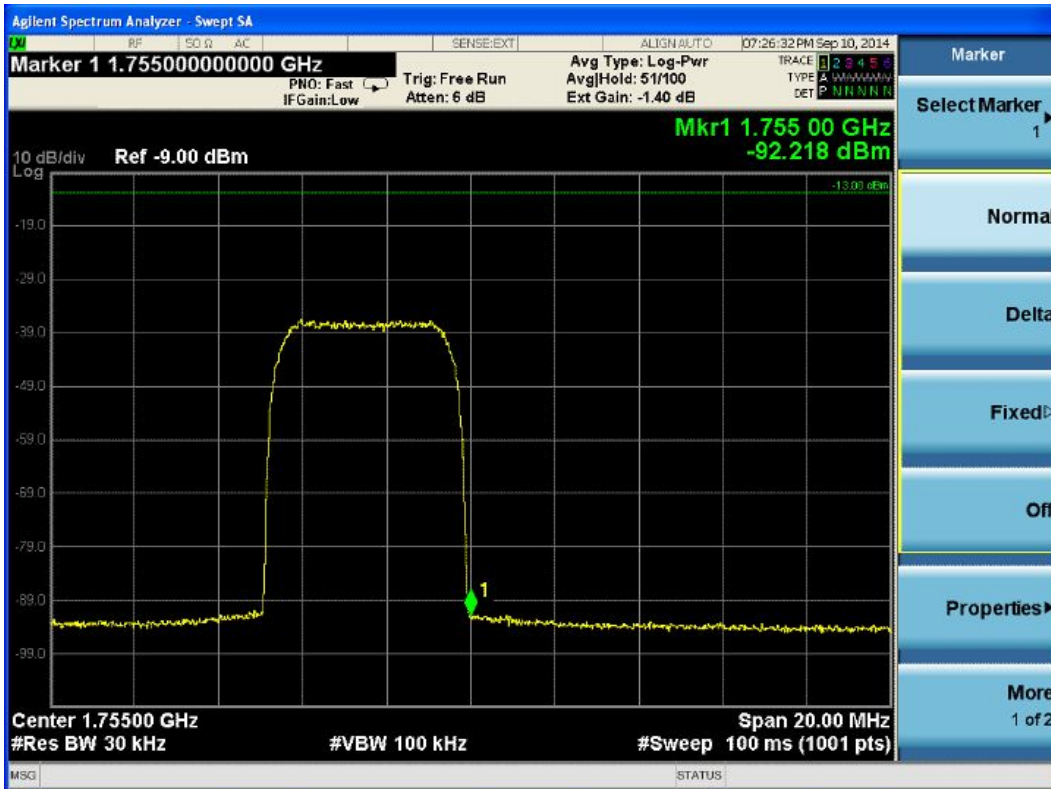

(4) 1x EV-DO modulation

(4.1) Lower Edge

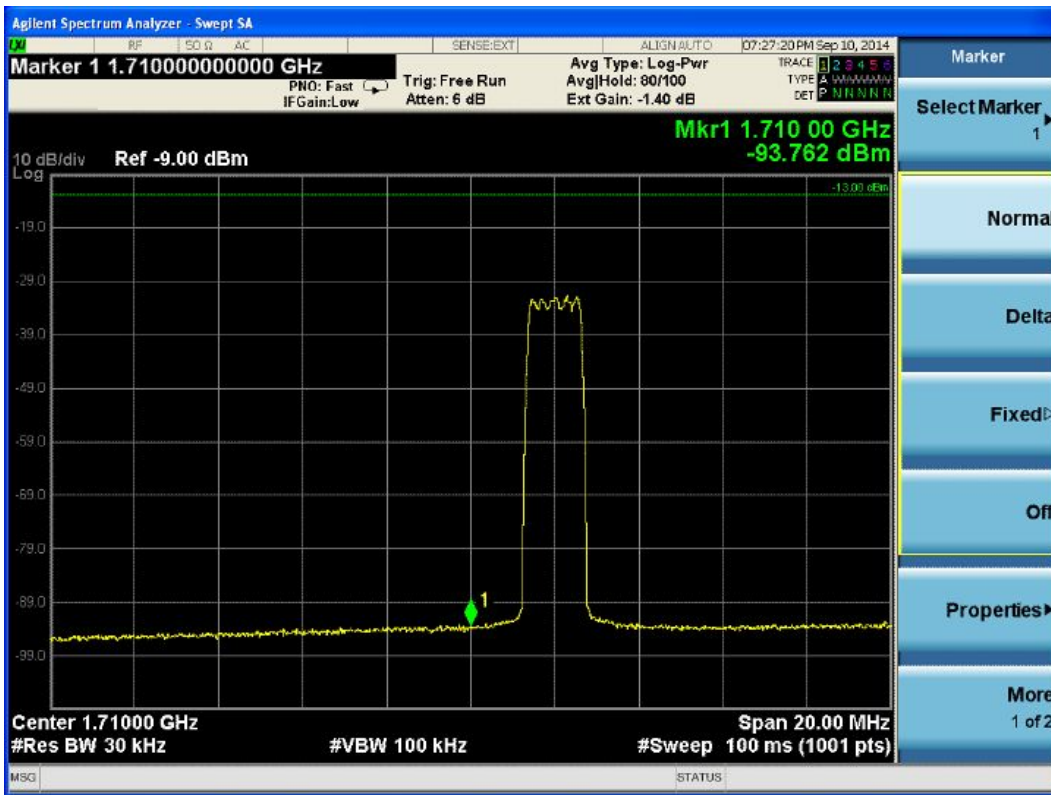

(4.2) Upper Edge

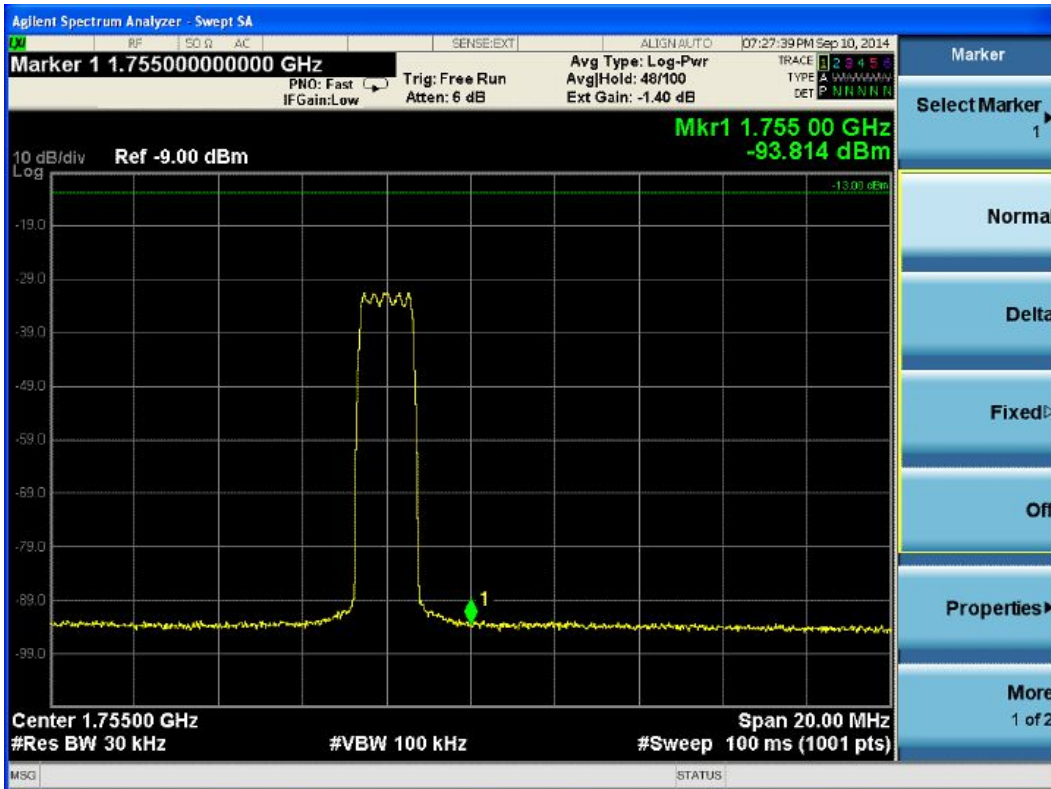

5.2.4 Intermodulation

Test Date:	Sep 12, 2014 to Sep 15, 2014
Ambient Temp:	28.3°C
Humid :	61%
Atmospheric Pressure:	101kPa
Power supply:	AC 120V 60Hz
Test Method:	935210 D02 Signal Boosters Certification v02r01
Test Requirement:	
700MHz Lower ABC Band	FCC part 27. 53 The power of any emission outside a licensee's frequency block shall be attenuated below the transmitting power (P) by at least $43 + 10 \log (P)$ dB, or -13 dBm.
700MHz Upper C Band	FCC part 27. 53 The power of any emission outside a licensee's frequency block shall be attenuated below the transmitting power (P) by at least $43 + 10 \log (P)$ dB, or -13 dBm.
800MHz Band	FCC part 90. 210 The power of any emission outside a licensee's frequency block shall be attenuated below the transmitting power (P) by at least $43 + 10 \log (P)$ dB, or -13 dBm.
850MHz Band	FCC part 22. 917 The power of any emission outside a licensee's frequency block shall be attenuated below the transmitting power (P) by at least $43 + 10 \log (P)$ dB, or -13 dBm.
1900MHz Band	FCC part 24. 238 The power of any emission outside a licensee's frequency block shall be attenuated below the transmitter power (P) by a factor of at least $43 + 10 \log (P)$ dB, or -13 dBm.
AWS-1 Band	FCC part 27. 53 The power of any emission outside a licensee's frequency block shall be attenuated below the transmitter power (P) by at least $43 + 10 \log (P)$ dB, or -13 dBm.
EUT Operation:	The output power of EUT be set to maximum value, the gain of EUT be set to maximum value by software through the manufacture
Test conditions:	Normal conditions

Test configuration:

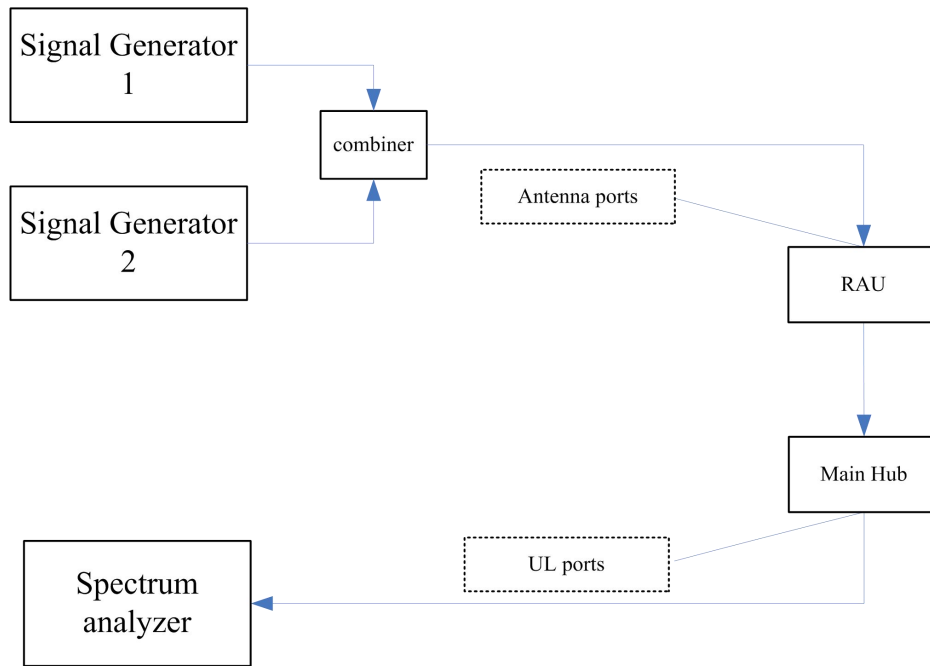
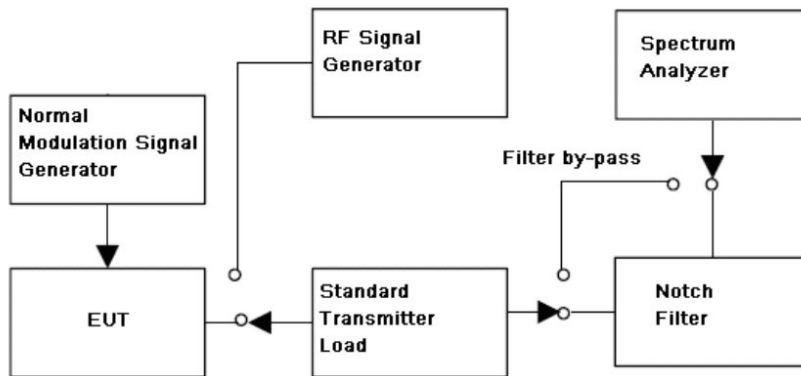

Figure 4: Uplink Intermodulation Configuration



Test Procedure:

Intermodulation test procedure:

- a) Connect the equipment as illustrated;
- b) Test the background noise level with all the test facilities;
- c) Keep one transmitting path, all other connectors shall be connected by normal power or RF leads;
- d) Select the attenuator to avoid the test receiver or spectrum analyzer being destroyed;
- e) Keep the EUT continuously transmitting in max power;
- f) Keep two signal generator produce two signal are same in modulation type and level;
- g) Measurement the 3 order intermodulated produced by the EUT(the sum of the two unwanted signal should be rated power);

- h) Correct for all losses in the RF path;
- i) Read the conducted spurious emission of the EUT antenna port. CW signal rather than typical signal is acceptable (for FM), At maximum drive level, for each modulation: one test with three tones, or two test (high, low-band edge) with two tones;
Limit usually is -13 dBm conducted;
Not need for single channel systems;
Combination of modulation types not needed;

Remark:

For the test in two signal input or intermodulation, test input signal f_1 and f_2 will consider as follows conditions:

- 1) EUT frequency band span and the amount of channels;
- 2) f_1 is the center frequency of lower channel, f_2 is the center frequency of higher channel, Δf is the channel spacing;
- 3) in lower edge test, f_1 is the center frequency of lower channel, and f_2 is $f_1 + 1$ channel frequency;
- 4) in higher edge test, f_2 is the center frequency of higher channel, and f_1 is $f_2 - 1$ channel frequency;
- 5) according to the amplifier characteristic, the 3rd product will be appeared when two signals input;
- 6) base the 3rd product frequency $F_1=2f_1-f_2$ and $F_2=2f_2-f_1$, when the f_1 and f_2 frequency select above:
 - a) in lower edge test, $F_1=2f_1-f_2=2f_1-(f_1+\Delta f)=f_1-\Delta f$
 - b) in higher edge test, $F_2=2f_2-f_1=f_2+\Delta f$

5.2.4.1 Measurement Record

5.2.4.1.1 700MHz Lower ABC Band for Downlink

(1) 700MHz Lower A LTE modulation

(1.1) Test for LTE 1.4MHz

(1.1.1) Lower Edge

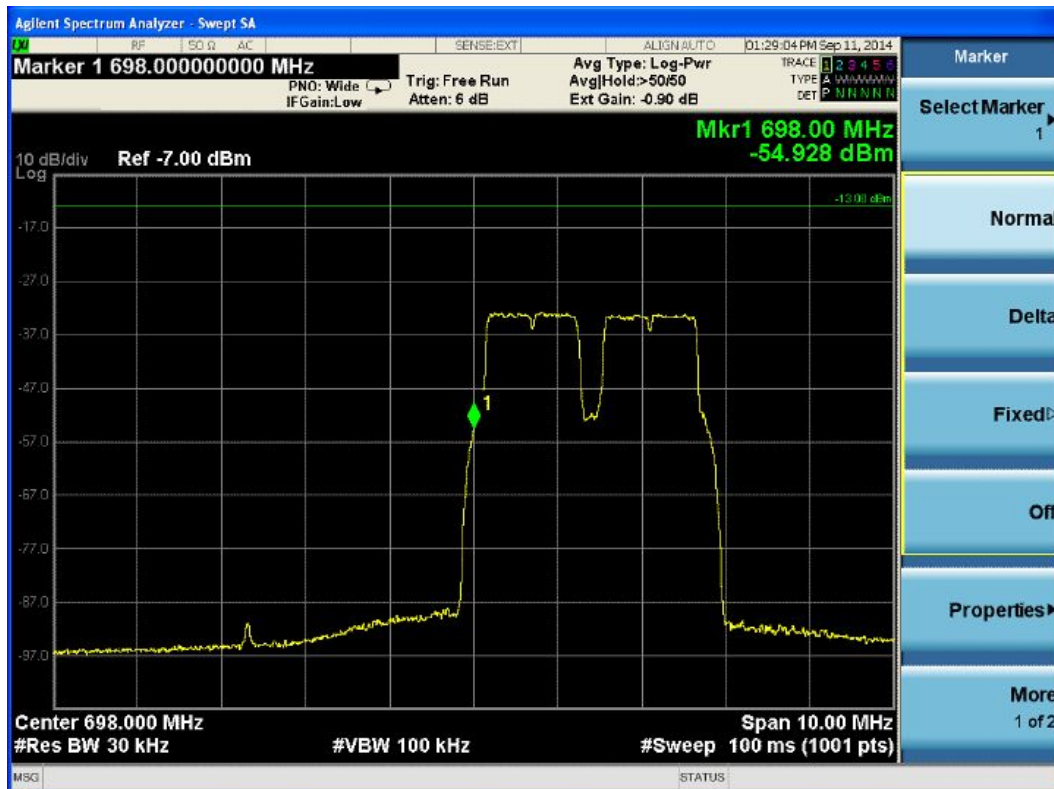

(1.1.2) Upper Edge

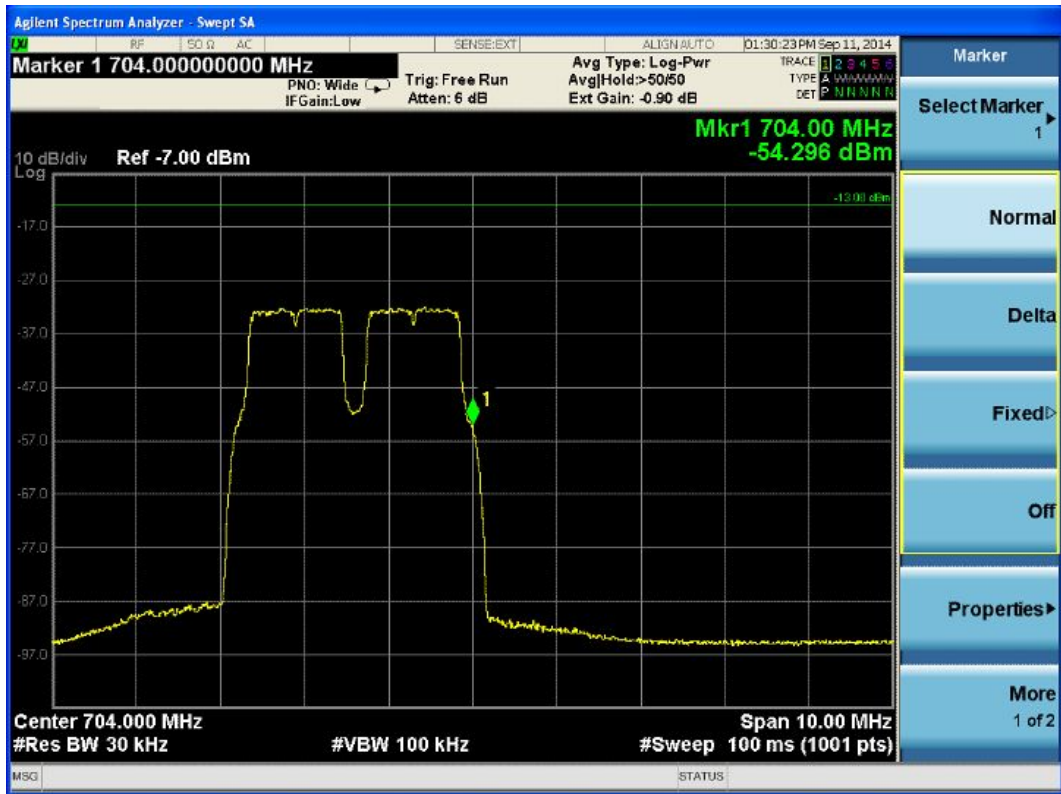

(1.2) Test for LTE 3 MHz

(1.2.1) Lower Edge

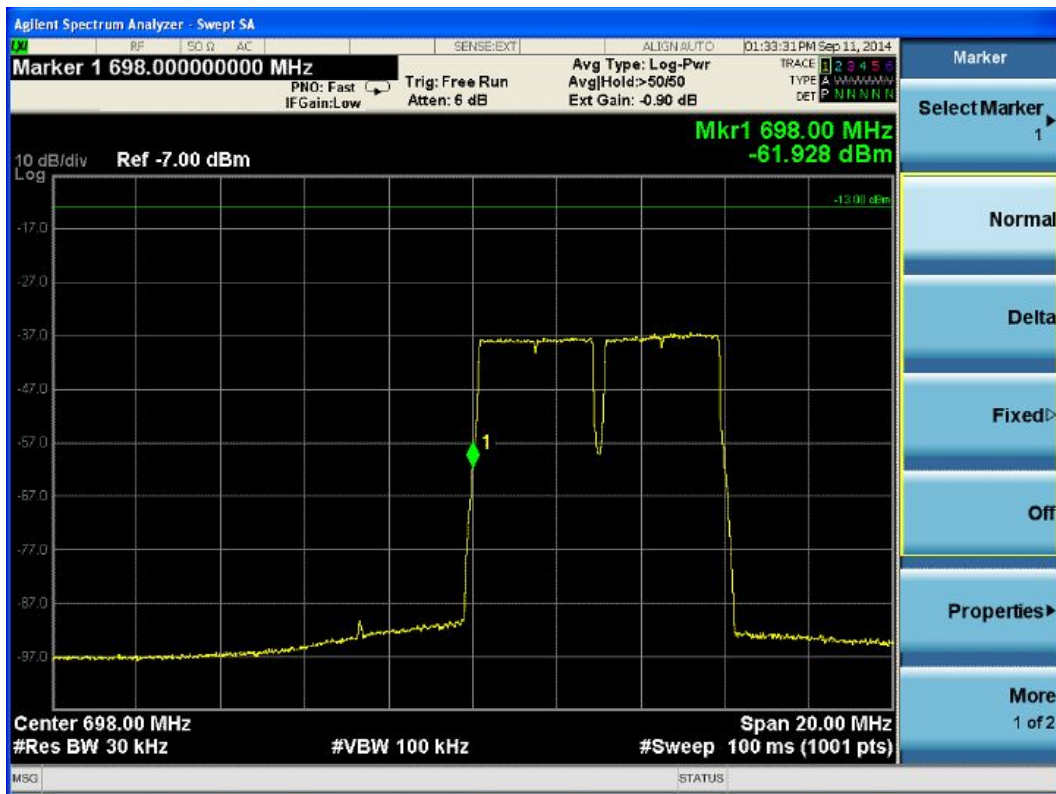

(1.2.2) Upper Edge



(1.3) Test for LTE 5MHz

(1.3.1) Lower Edge



(1.3.2) Upper Edge

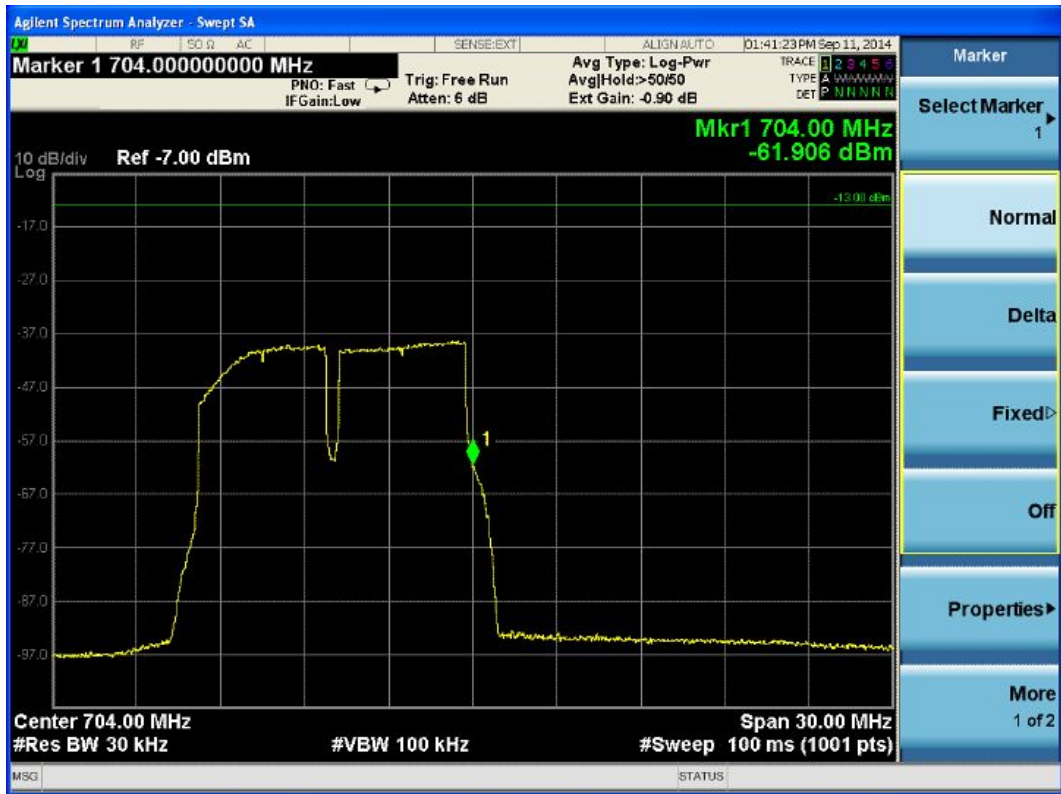

(2) 700MHz Lower B LTE modulation

(2.1) Test for LTE 1.4MHz

(2.1.1) Lower Edge

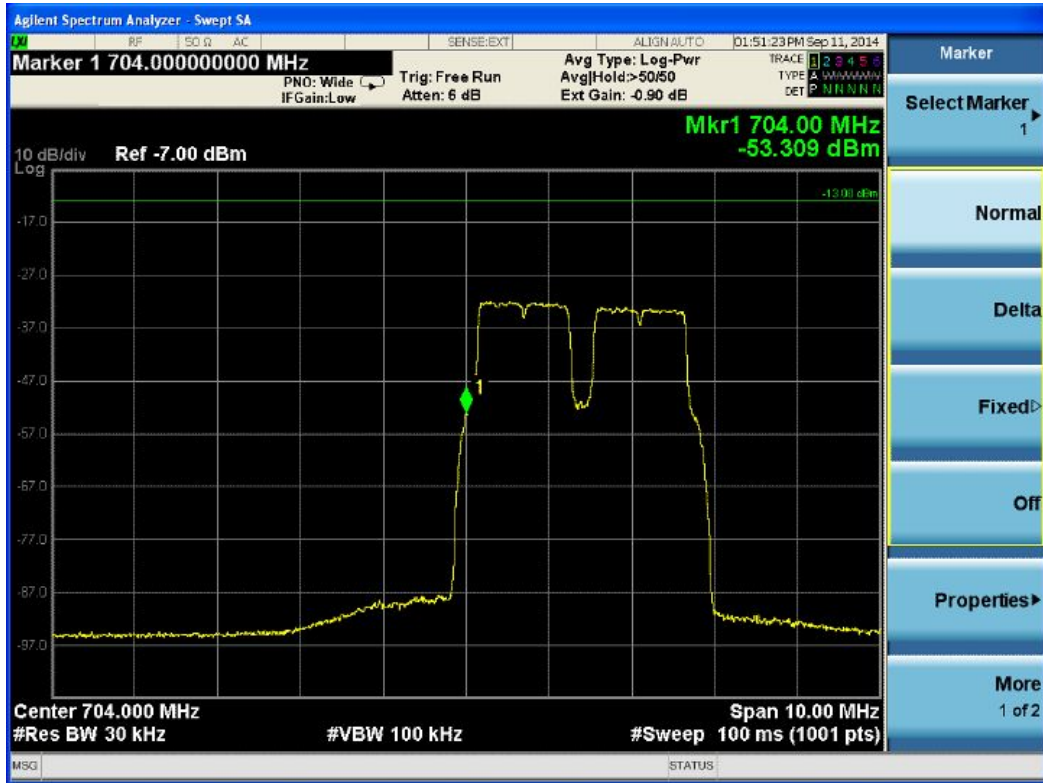

(2.1.2) Upper Edge

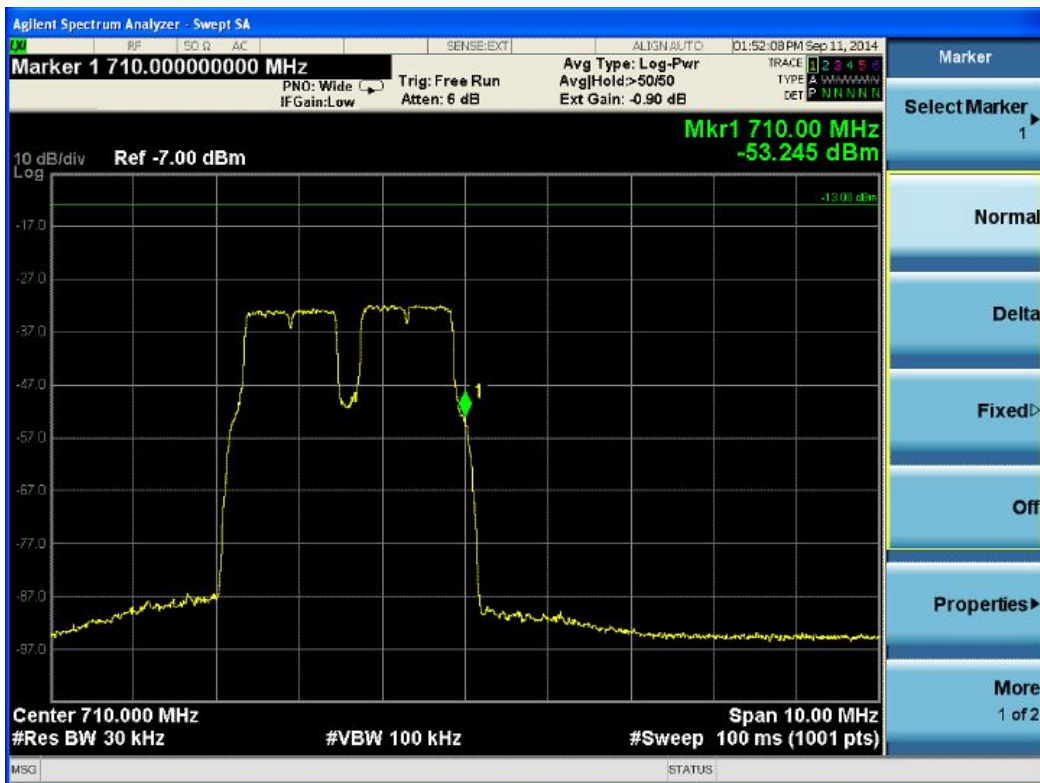

(2.2) Test for LTE 3 MHz

(2.2.1) Lower Edge

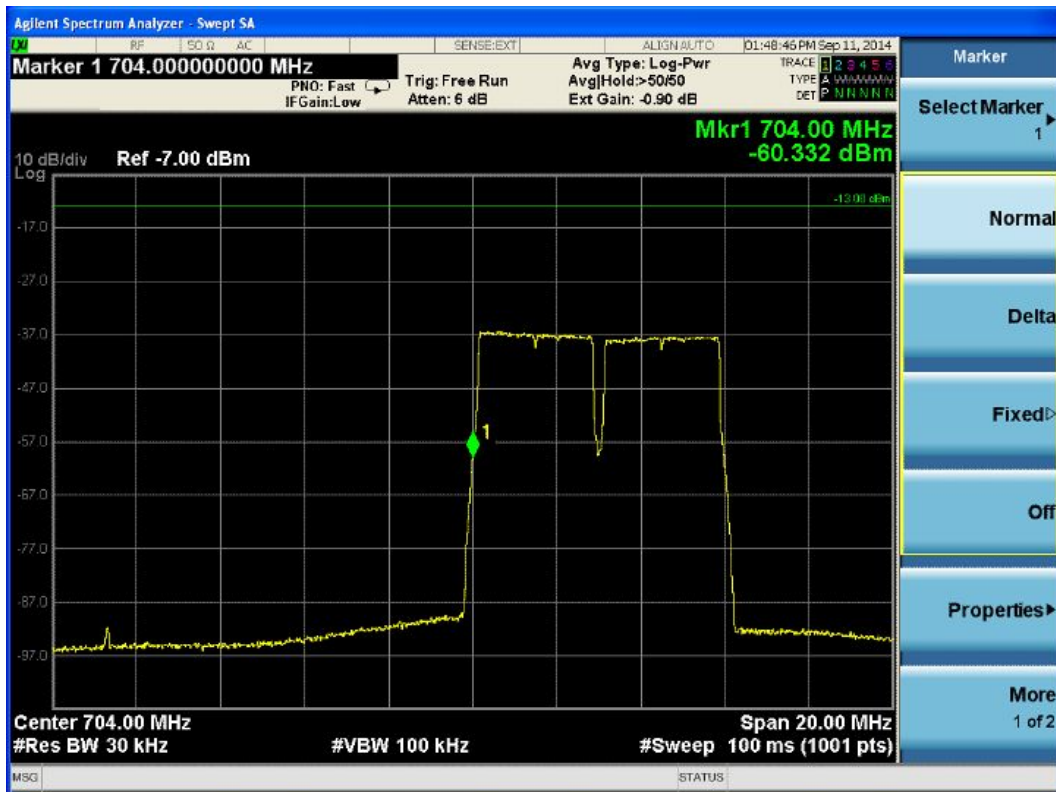

(2.2.2) Upper Edge

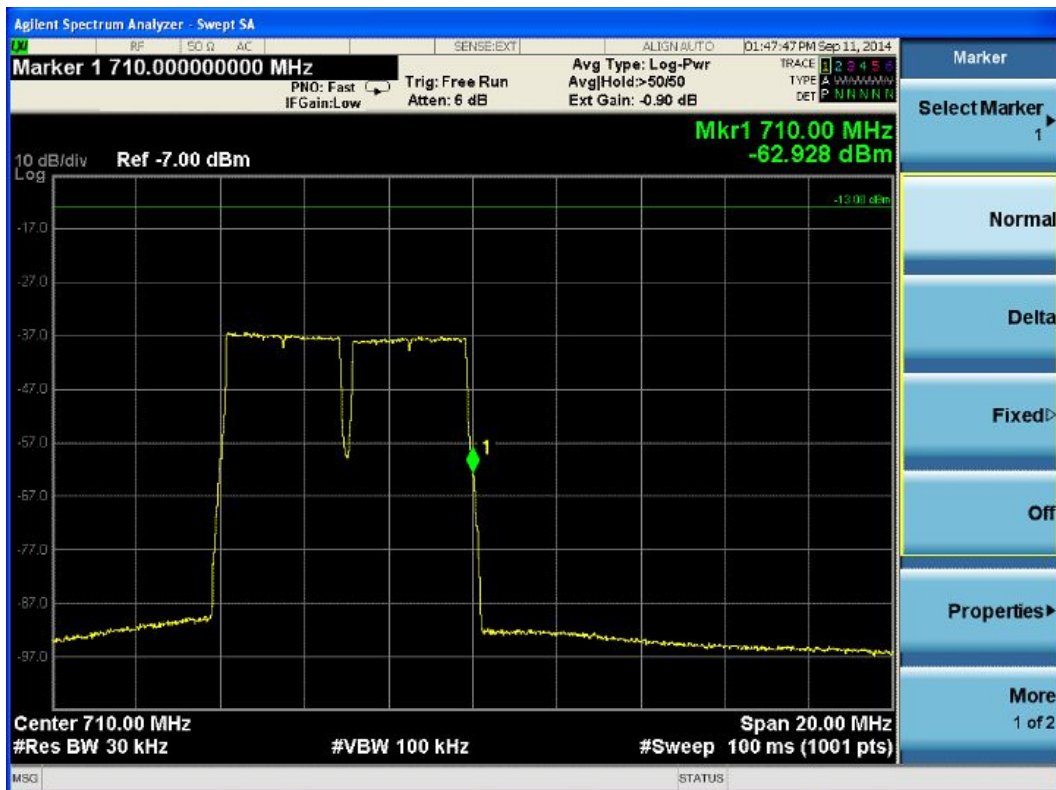

(2.3) Test for LTE 5 MHz

(2.3.1) Lower Edge

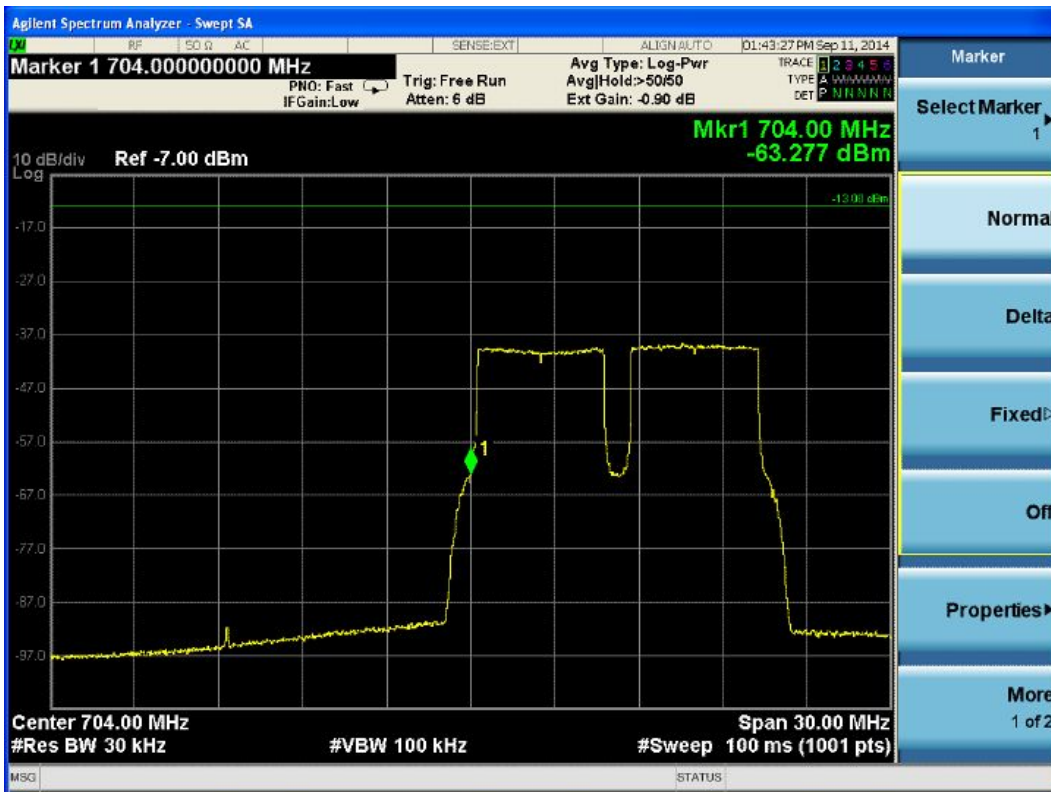

(2.3.2) Upper Edge

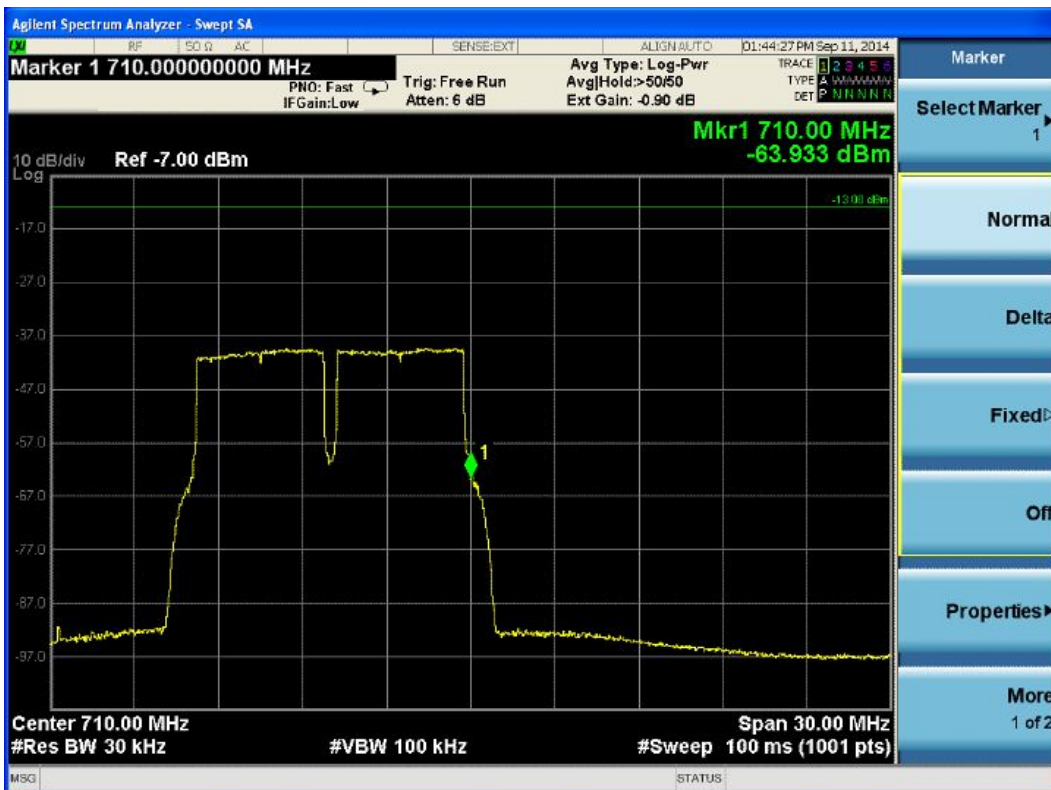

(3) 700MHz Lower C LTE modulation

(3.1) Test for LTE 1.4MHz

(3.1.1) Lower Edge

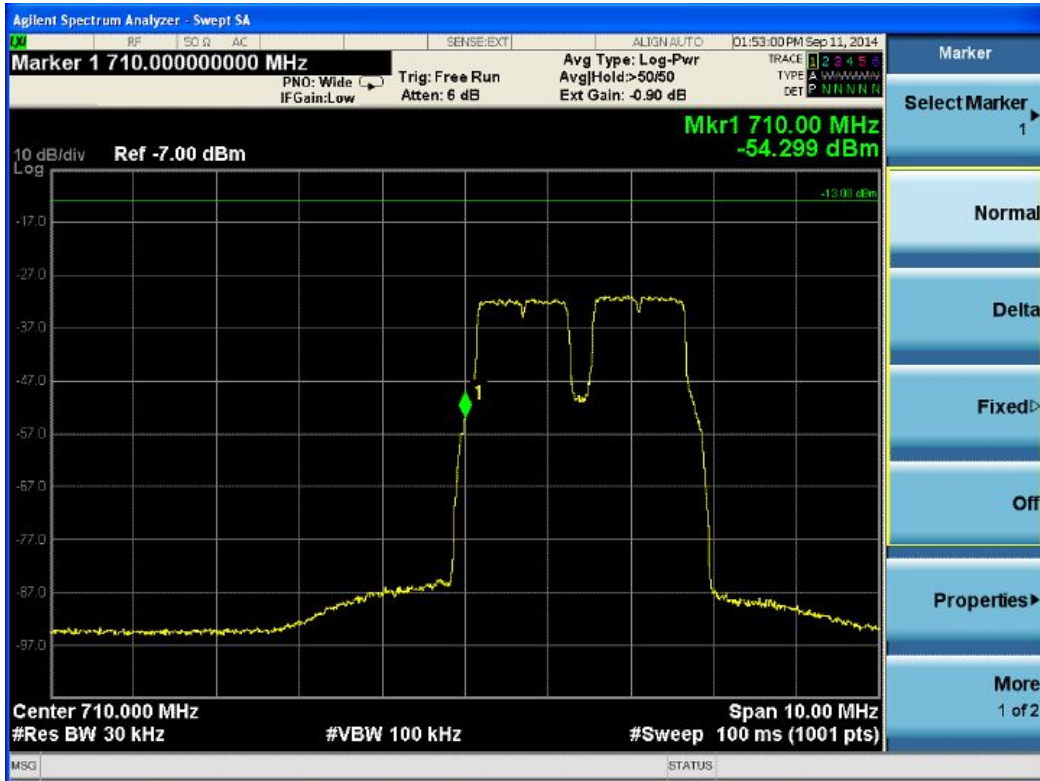

(3.1.2) Upper Edge

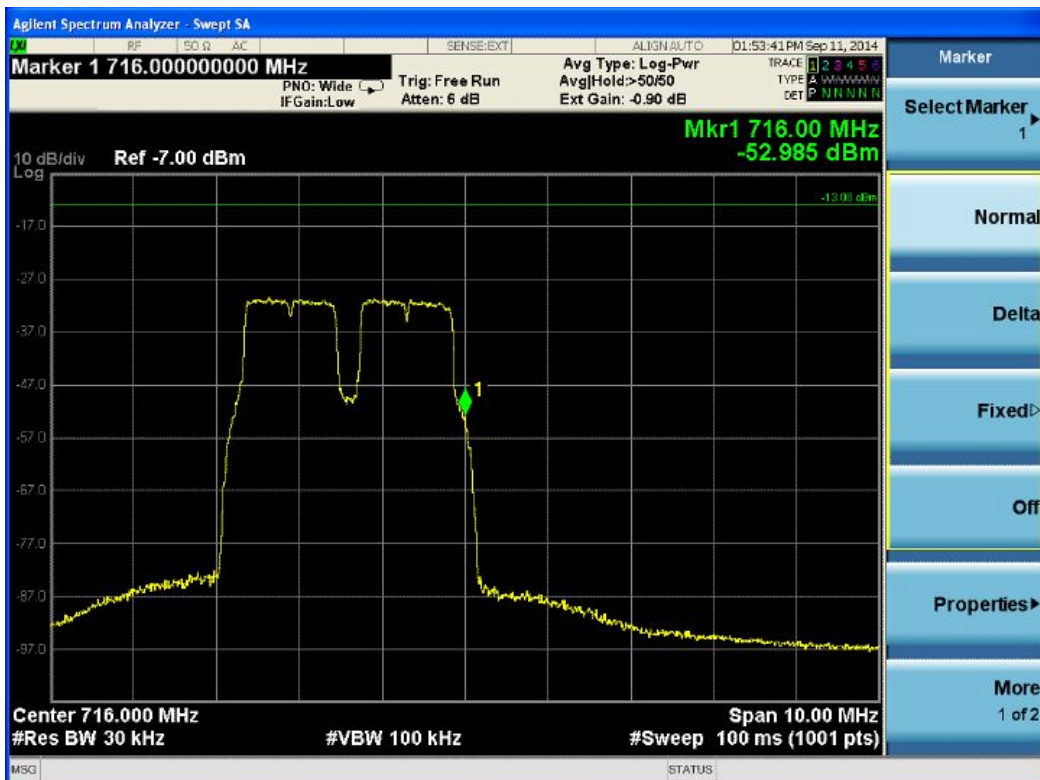

(3.2) Test for LTE 3MHz

(3.2.1) Lower Edge

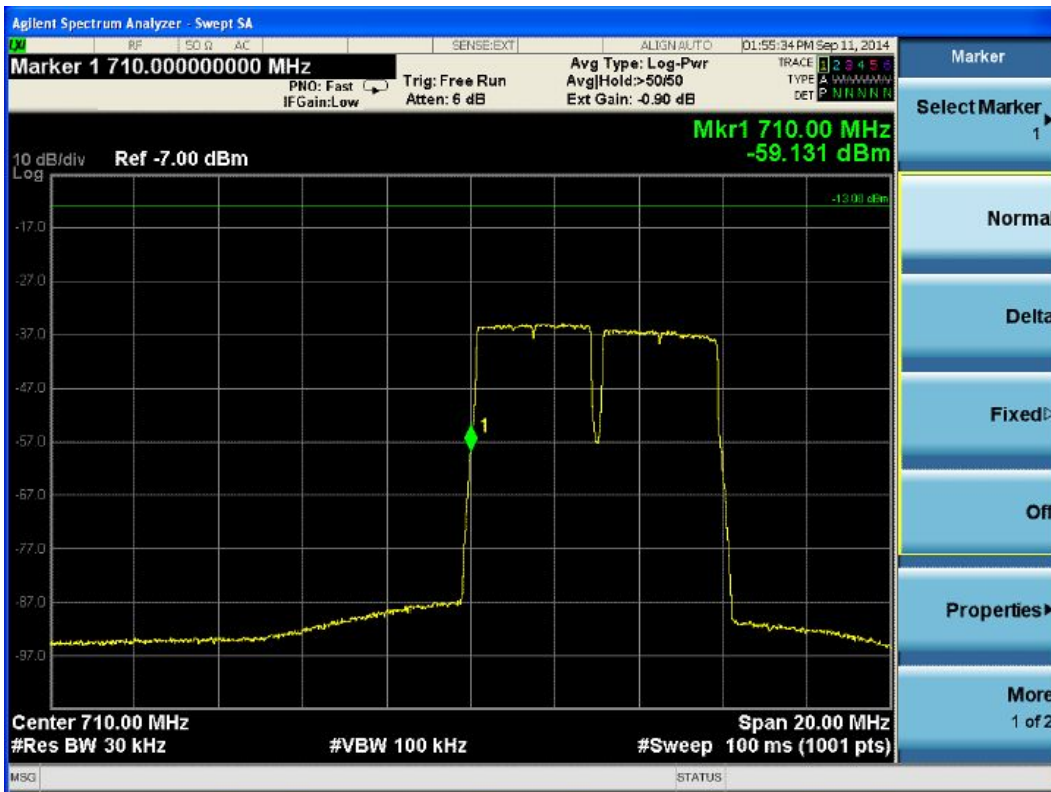

(3.2.2) Upper Edge

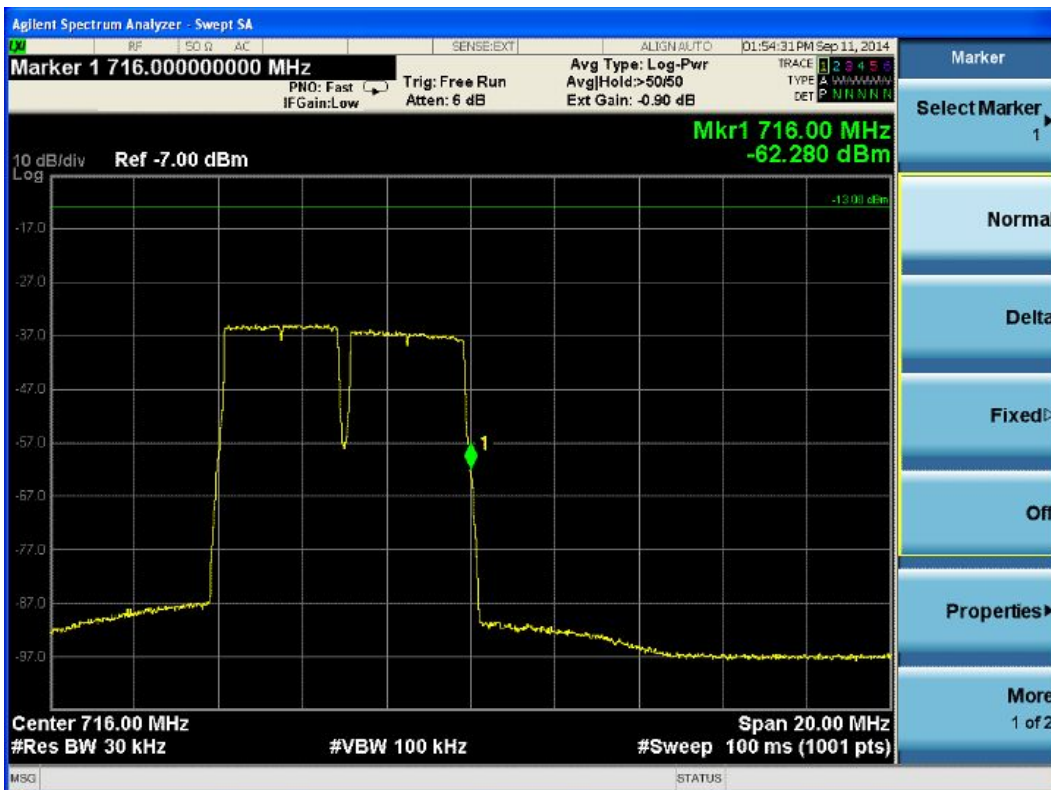

(3.3) Test for LTE 5 MHz

(3.3.1) Lower Edge

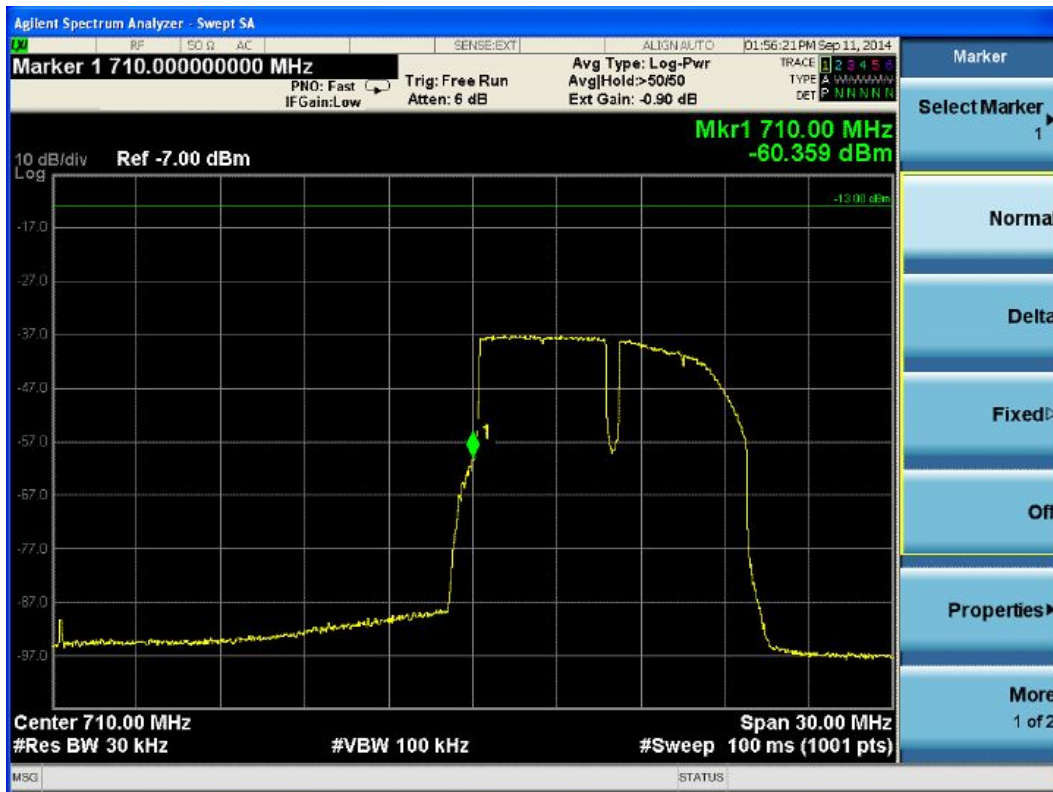

(3.3.2) Upper Edge

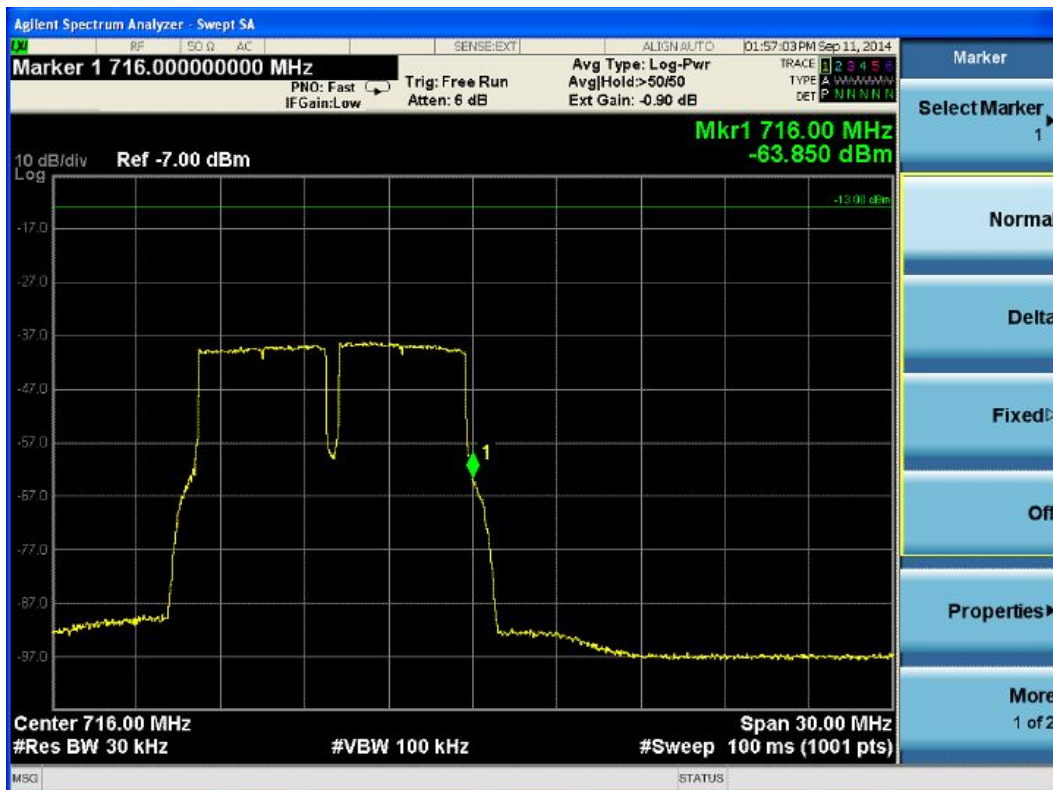

(4) 700MHz Lower ABC LTE modulation

(4.1) Test for LTE 10MHz

(4.1.1) Lower Edge

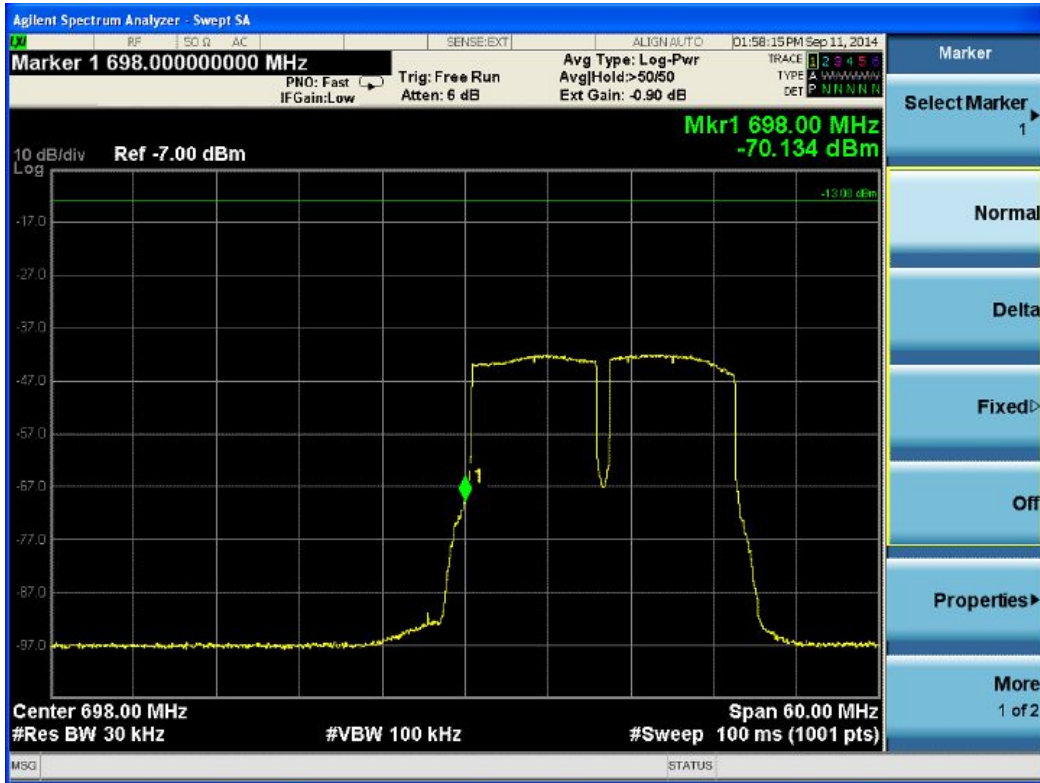

(4.1.2) Upper Edge

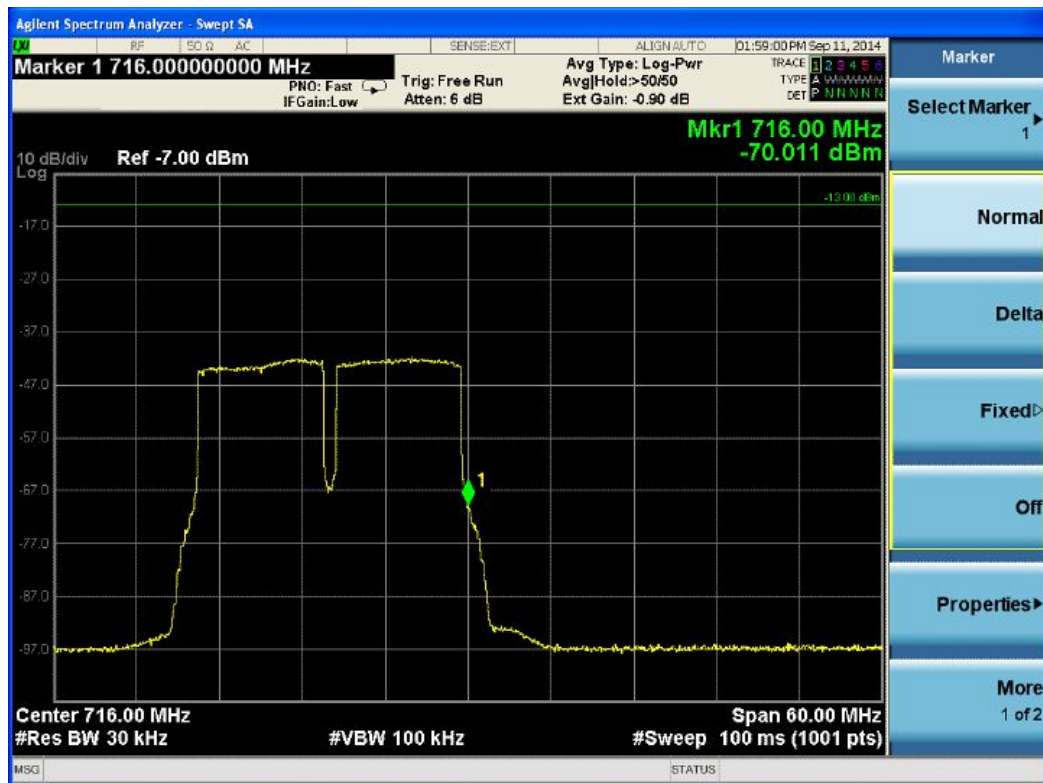

(4.2) Test for LTE 15MHz

(4.2.1) Lower Edge

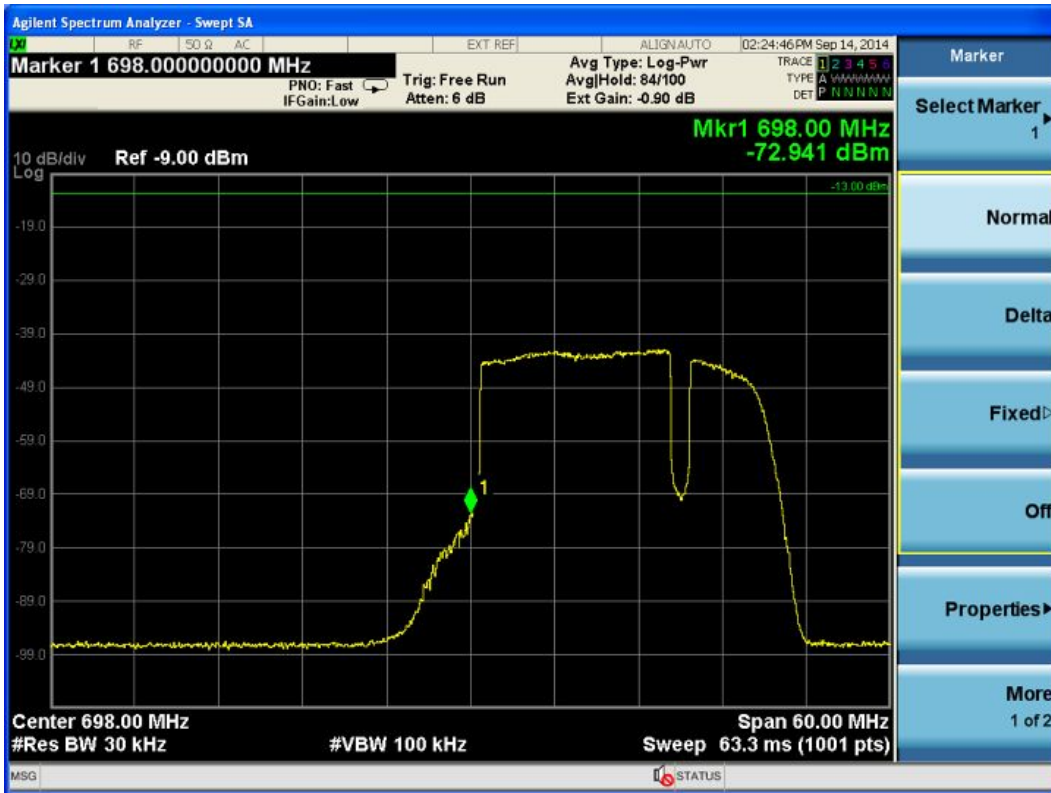

(4.2.2) Upper Edge

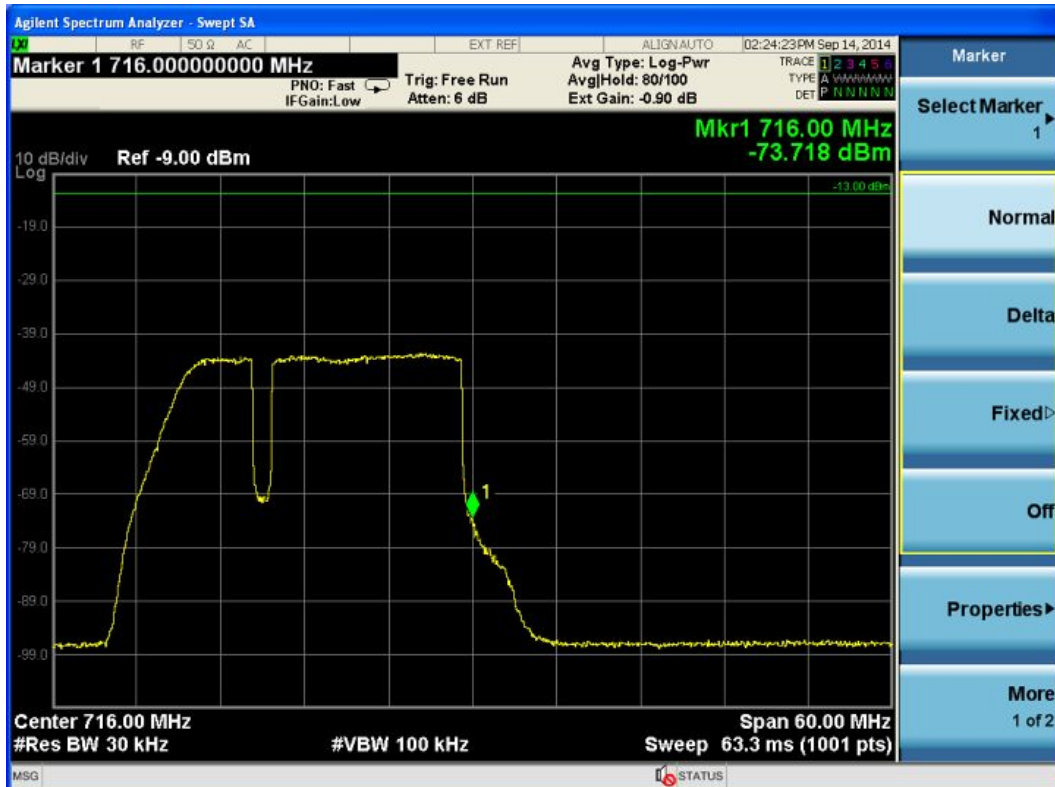

5.2.4.1.2 700MHz Upper C Band for Downlink

(1) LTE modulation

(1.1) Test for LTE 1.4MHz

(1.1.1) Lower Edge

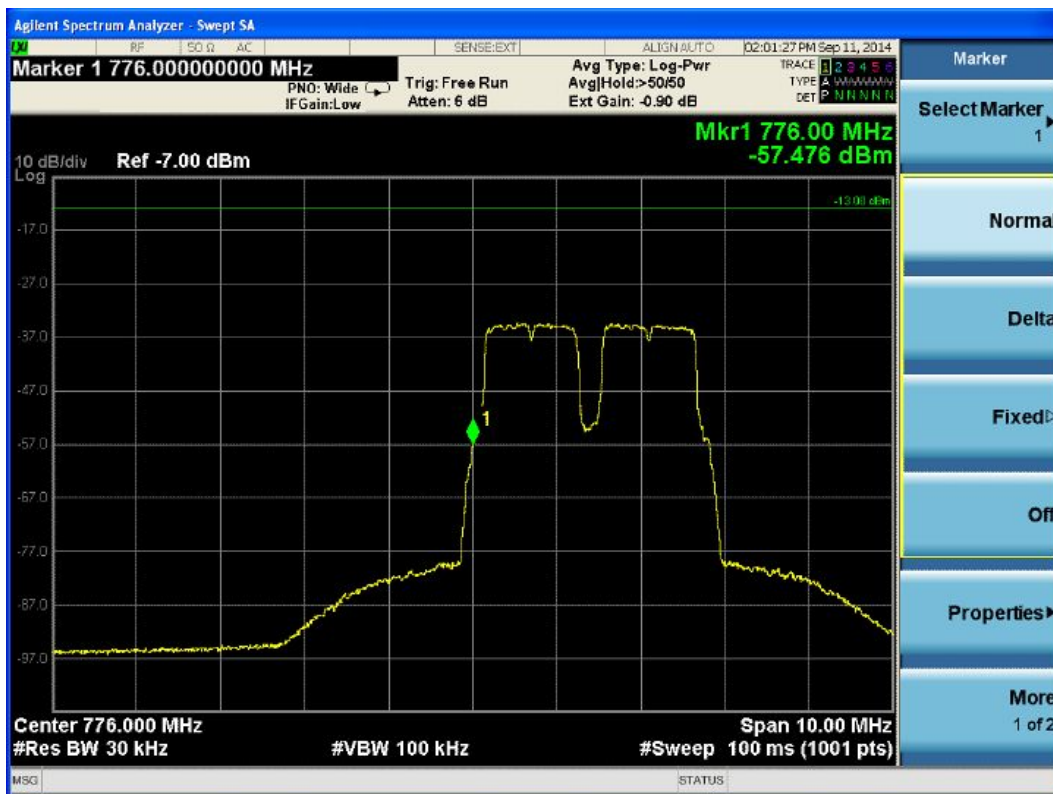

(1.1.2) Upper Edge

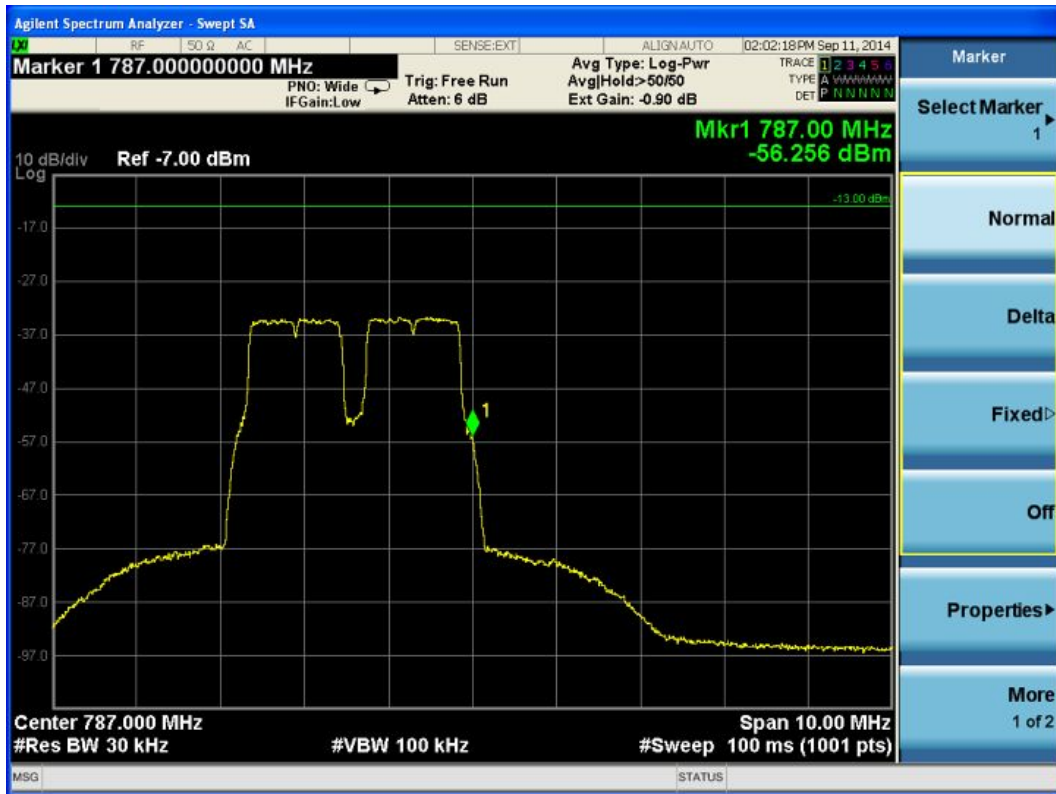

(1.2) Test for LTE 3MHz

(1.2.1) Lower Edge

