

(2.5) Highest frequency: 9 kHz to 1 GHz

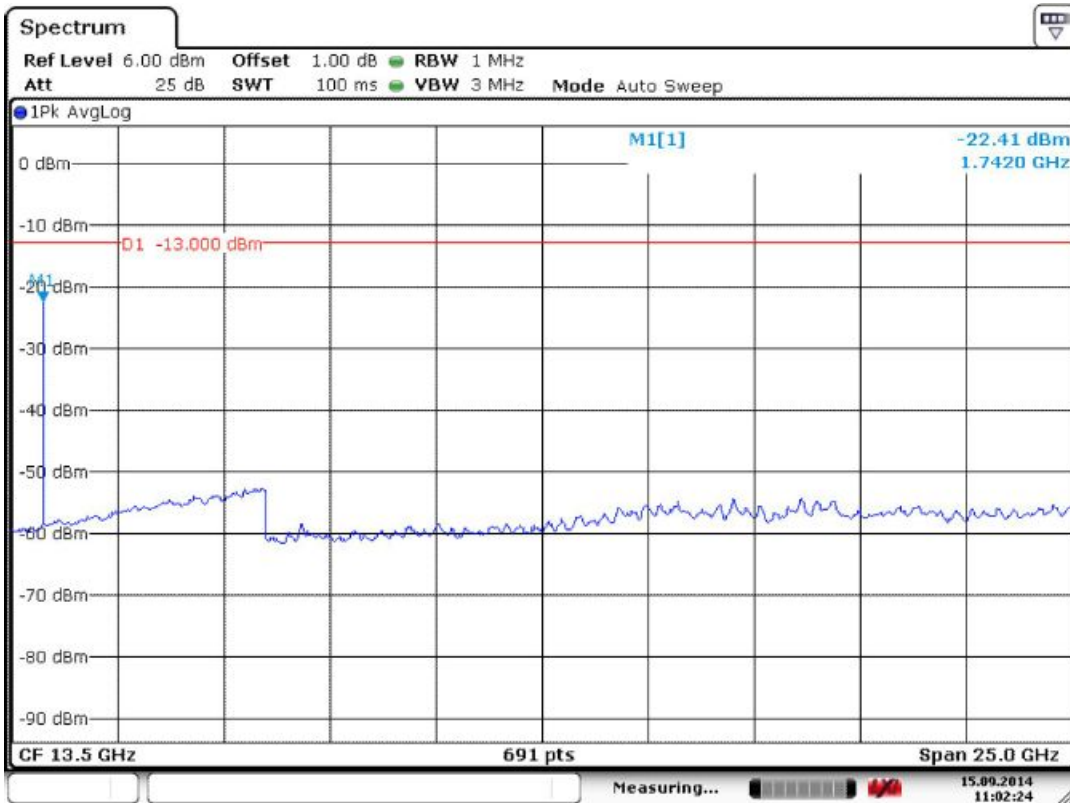

(2.6) Highest frequency: 1 GHz to 26 GHz



Date: 15.SEP.2014 11:02:23

(3) WCDMA modulation

(3.1) Lowest frequency: 9 kHz to 1 GHz

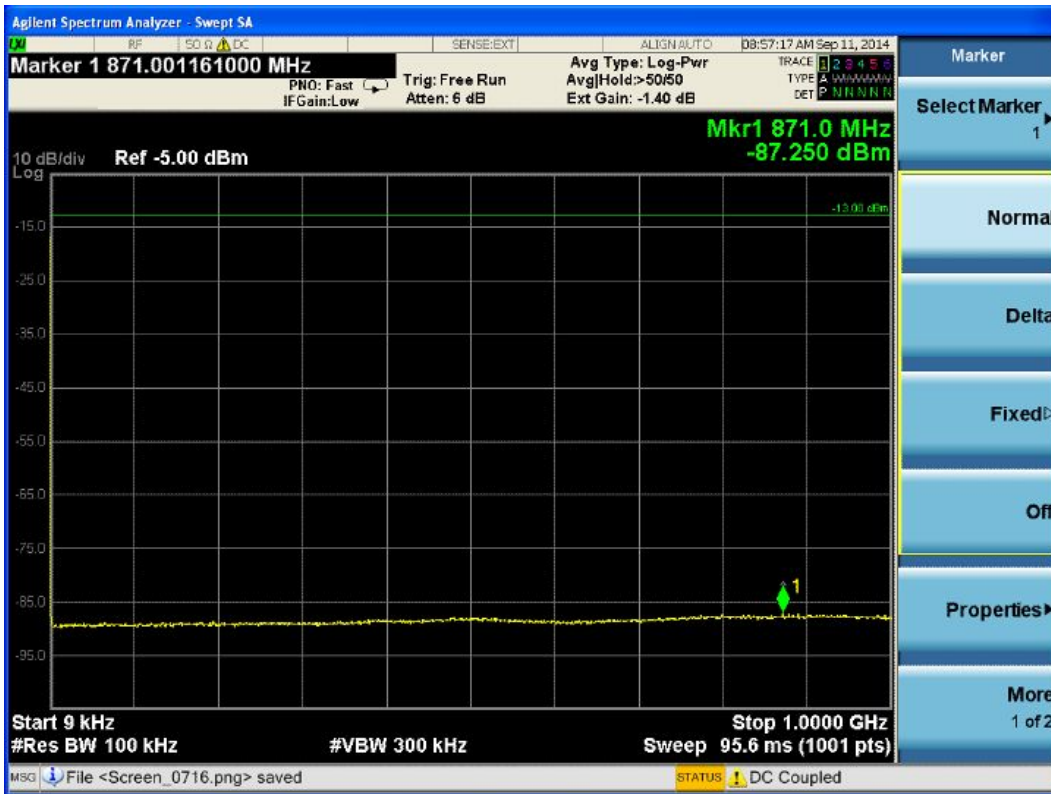

(3.2) Lowest frequency: 1 GHz to 26 GHz

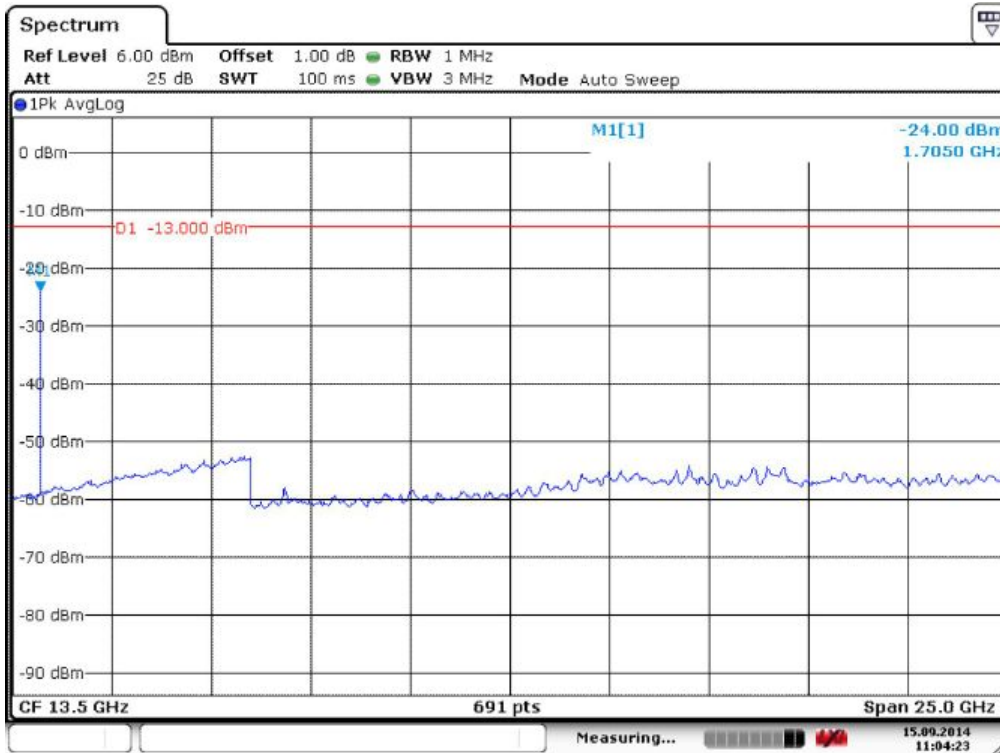

Date: 15.SEP.2014 11:04:22

(3.3) Middle frequency: 9 kHz to 1 GHz



(3.4) Middle frequency: 1 GHz to 26 GHz

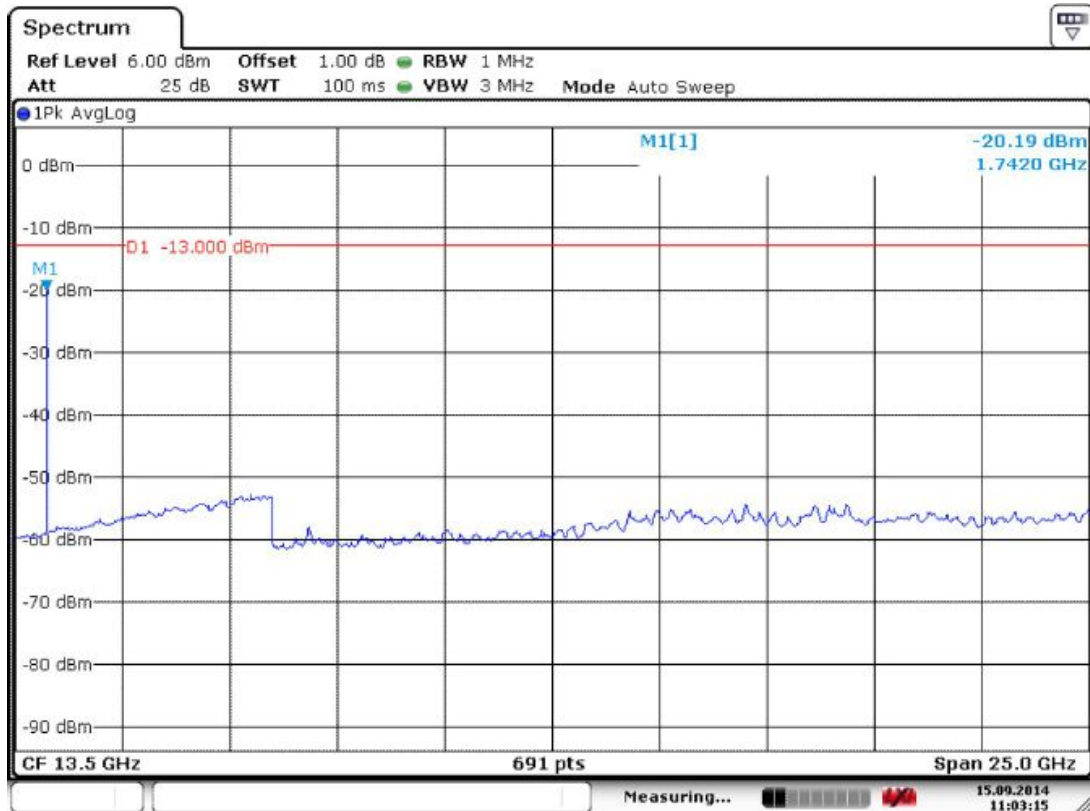

(3.5) Highest frequency: 9 kHz to 1 GHz



(3.6) Highest frequency: 1 GHz to 26 GHz

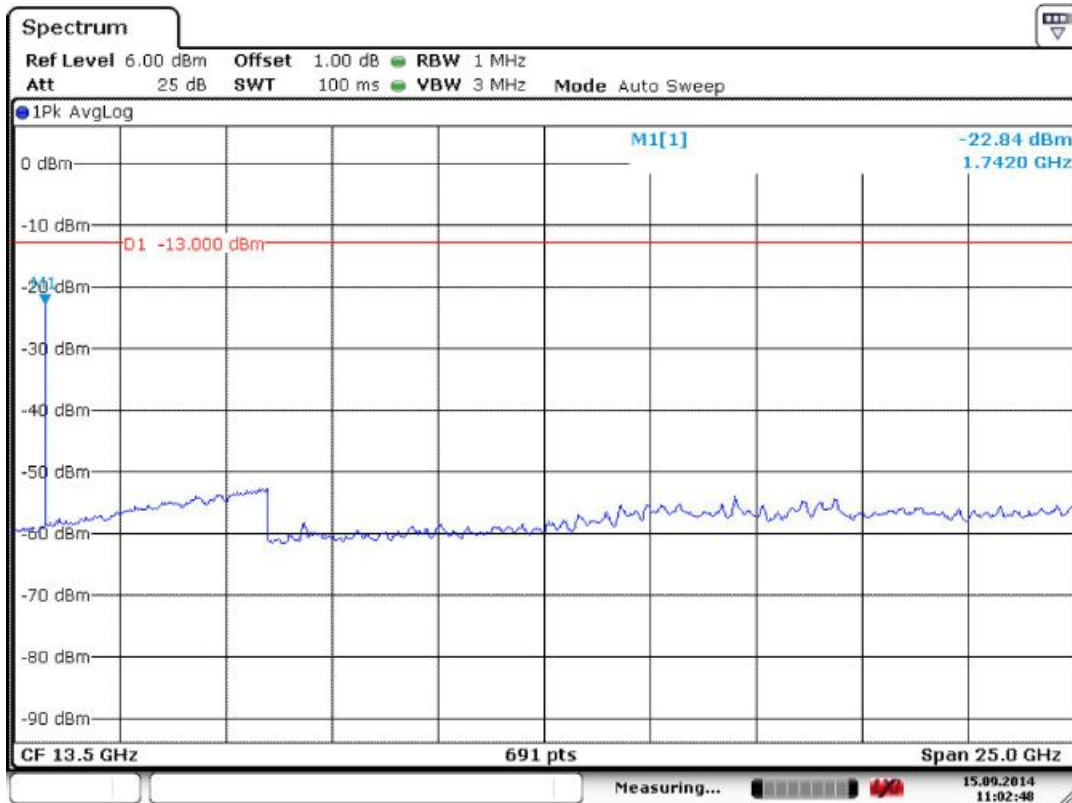

Date: 15.SEP.2014 11:02:47

(4) 1xEV-DO modulation

(4.1) Lowest frequency: 9 kHz to 1 GHz

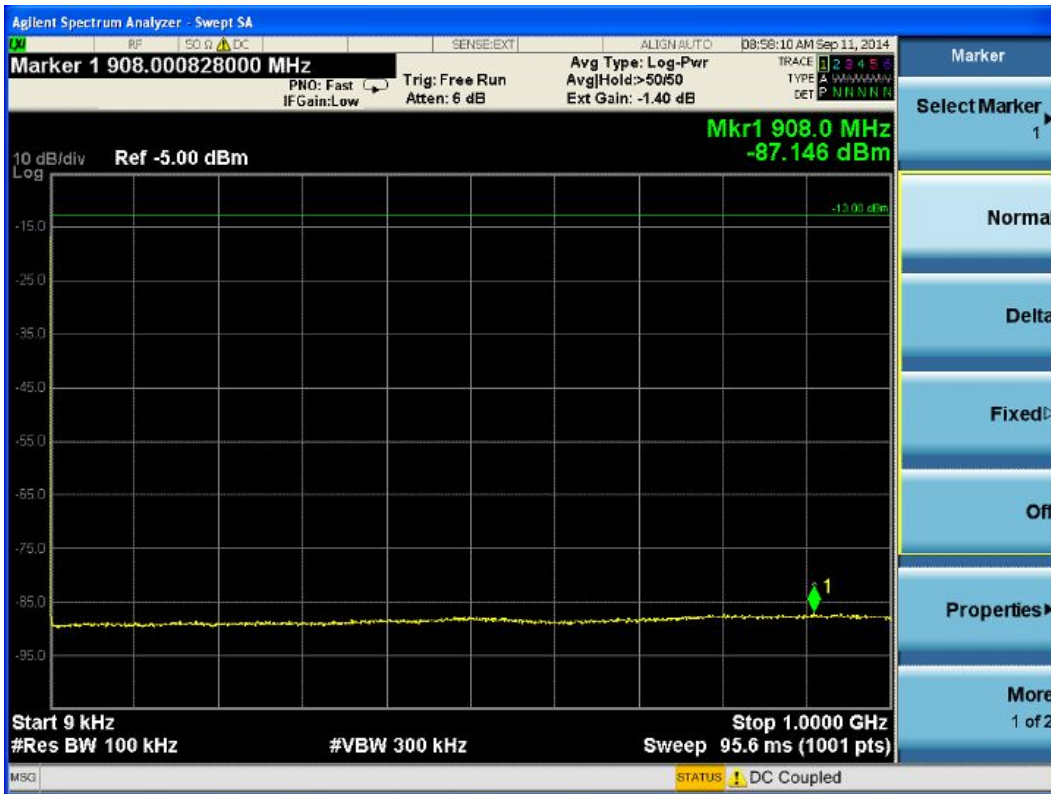

(4.2) Lowest frequency: 1 GHz to 26 GHz

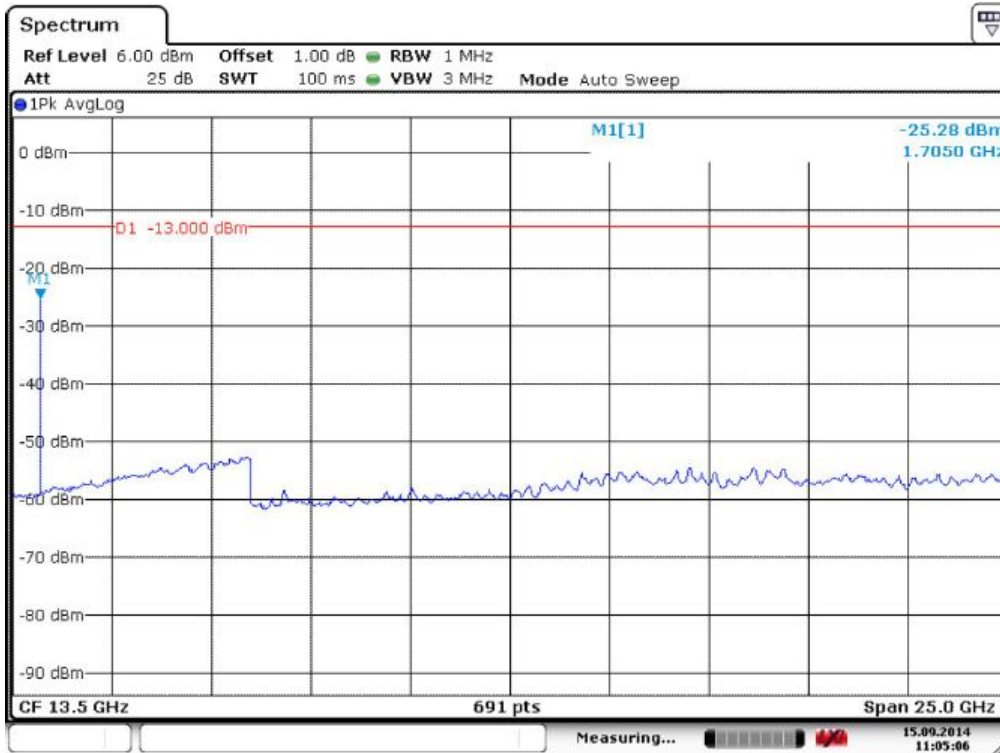

Date: 15.SEP.2014 11:05:05

(4.3) Middle frequency: 9 kHz to 1 GHz

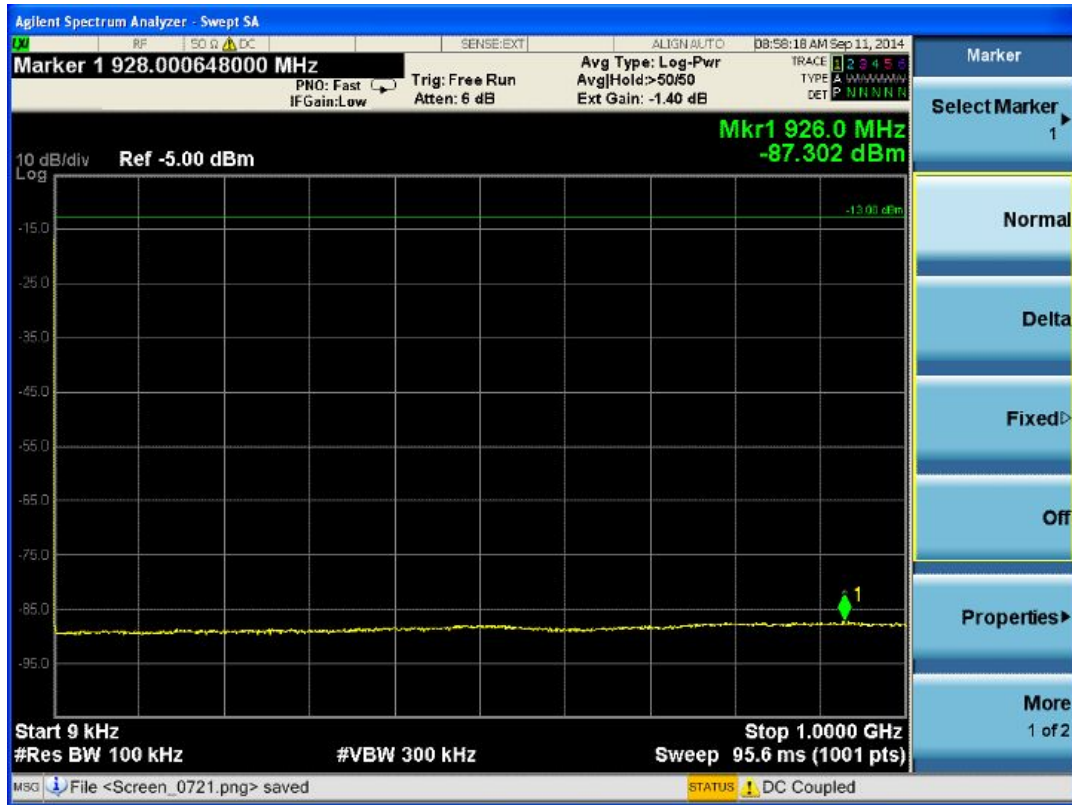

(4.4) Middle frequency: 1 GHz to 26 GHz

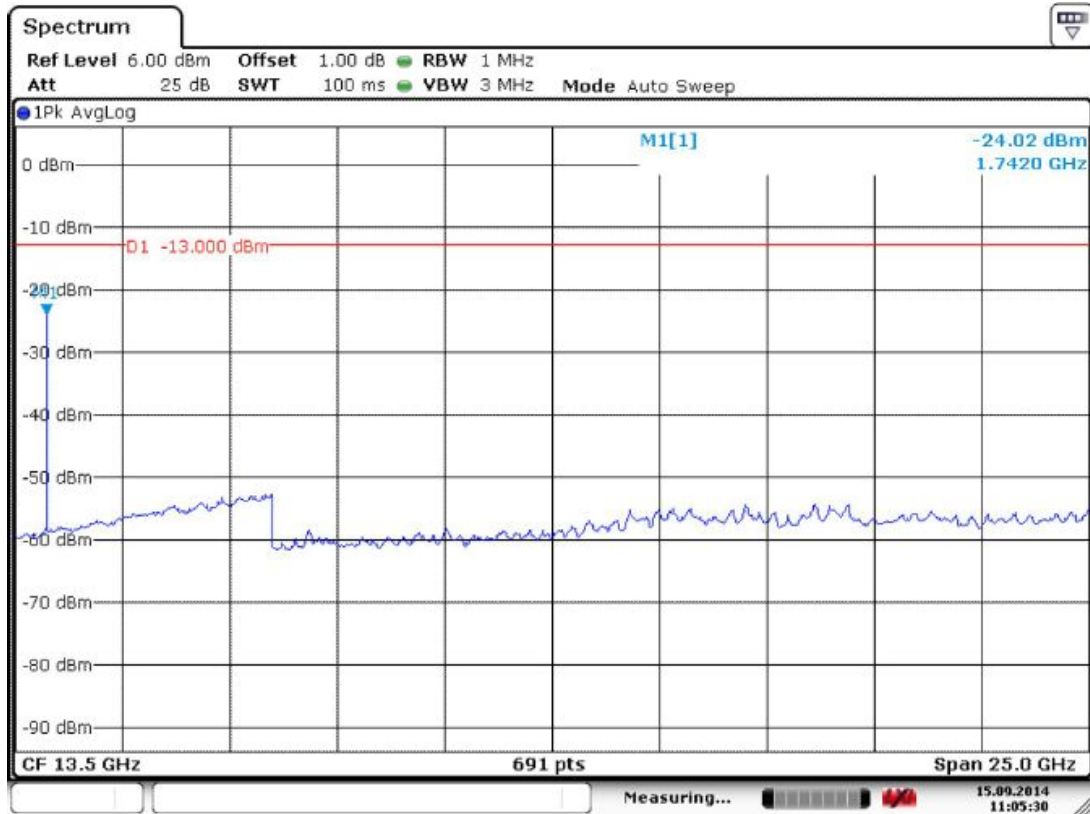

(4.5) Highest frequency: 9 kHz to 1 GHz

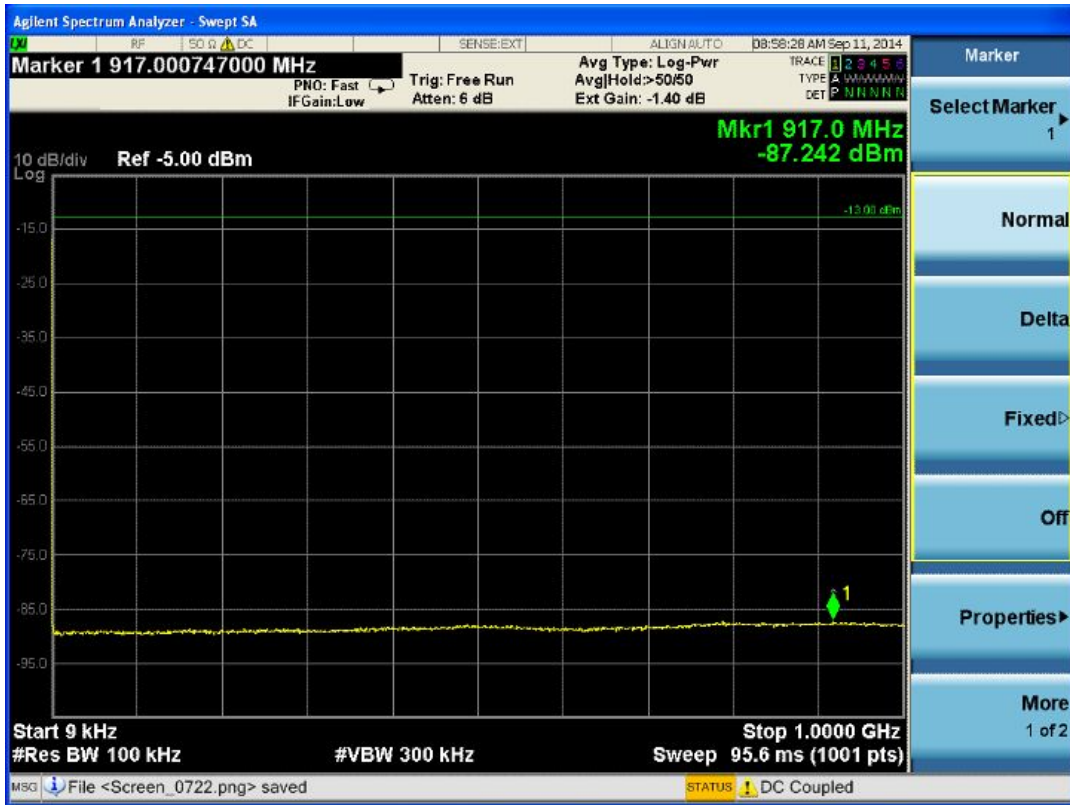

(4.6) Highest frequency: 1 GHz to 26 GHz

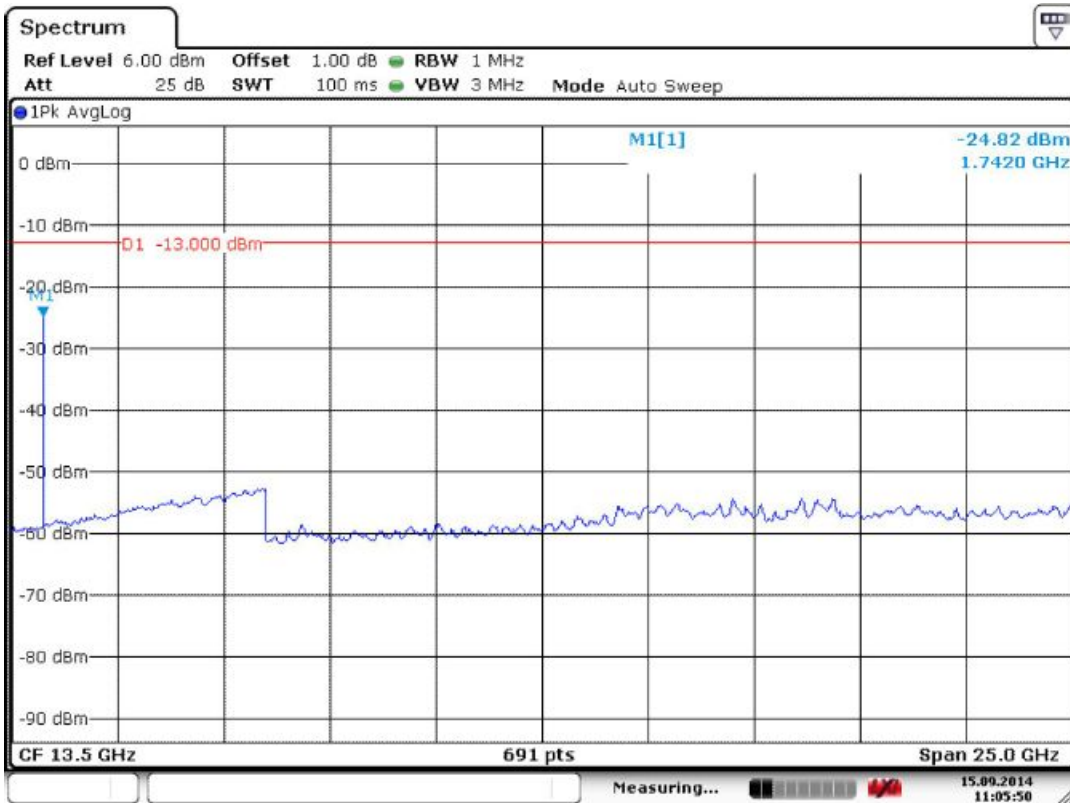

Date: 15.SEP.2014 11:05:49

5.2.3 Band Edge

Test Date:	Sep 12, 2014 to Sep 15, 2014
Ambient Temp:	28.3°C
Humid :	61%
Atmospheric Pressure:	101kPa
Power supply:	AC 120V 60Hz
Test Method:	FCC part 2. 1051& 935210 D02 Signal Boosters Certification v02r01
Test Requirement:	
700MHz Lower ABC Band	FCC part 27. 53 The power of any emission outside a licensee's frequency block shall be attenuated below the transmitting power (P) by at least $43 + 10 \log (P)$ dB, or -13 dBm.
700MHz Upper C Band	FCC part 27. 53 The power of any emission outside a licensee's frequency block shall be attenuated below the transmitting power (P) by at least $43 + 10 \log (P)$ dB, or -13 dBm.
800MHz Band	FCC part 90. 210 The power of any emission outside a licensee's frequency block shall be attenuated below the transmitting power (P) by at least $43 + 10 \log (P)$ dB, or -13 dBm.
850MHz Band	FCC part 22. 917 The power of any emission outside a licensee's frequency block shall be attenuated below the transmitting power (P) by at least $43 + 10 \log (P)$ dB, or -13 dBm.
1900MHz Band	FCC part 24. 238 The power of any emission outside a licensee's frequency block shall be attenuated below the transmitter power (P) by a factor of at least $43 + 10 \log (P)$ dB, or -13 dBm.
AWS-1 Band	FCC part 27. 53 The power of any emission outside a licensee's frequency block shall be attenuated below the transmitter power (P) by at least $43 + 10 \log (P)$ dB, or -13 dBm.
EUT Operation:	The output power of EUT be set to maximum value, the gain of EUT be set to maximum value by software through the manufacture
Test conditions:	Normal conditions

Test configuration:

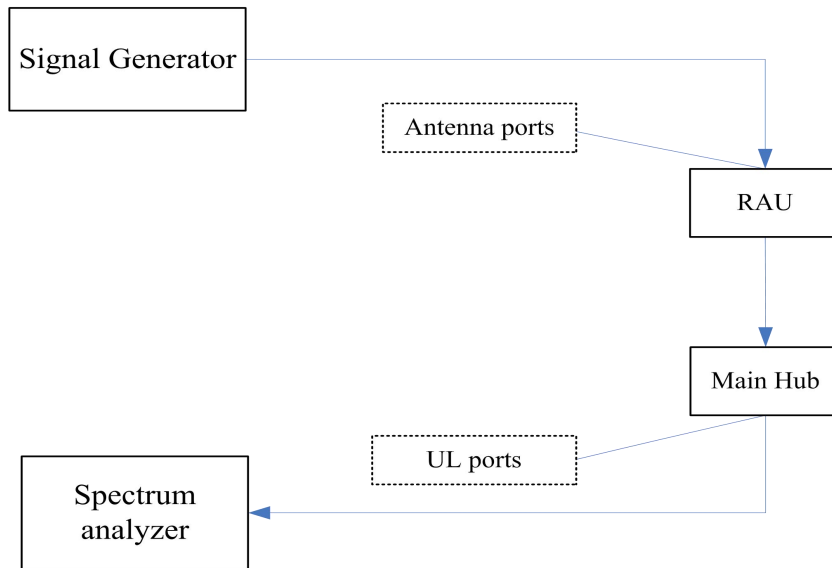
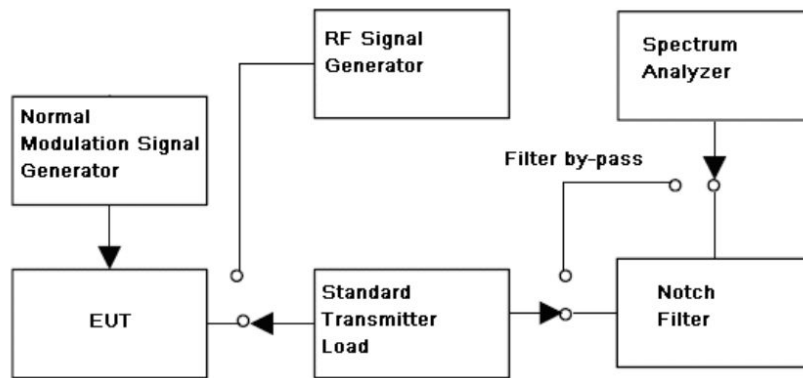

Figure 3: Uplink Band Edge Configuration



Test Procedure:

Band Edge conducted Emission test procedure:

- a) Connect the equipment as illustrated, when the output power is over the max value of the Spectrum Analyzer; add the attenuator to avoid destroying the facility.
- b) Set the center frequency of the Spectrum Analyzer to assigned transmitter frequency, and set the level of the carrier to the full scale reference line.
- c) Do not apply any tone to modulate the EUT
- d) Adjust the Spectrum Analyzer for the following setting:
 - 1) Resolution Bandwidth (base the standard, apply the different set), here is 100kHz for frequency band less than 1 GHz, 1 MHz for frequency over 1 GHz
 - 2) Video Bandwidth refer to standard requirement

- e) Adjust the center frequency of the spectrum analyzer for incremental coverage of the range from:

Use spectrum analyzer channel power measurement

- 1) the lowest radio frequency generated in the equipment, it can be 9 kHz base the test method, here select 30 MHz as lowest frequency start point;
 - 2) the highest radio frequency shall higher than 10 times of carrier frequency;
- f) Record the frequencies and levels of spurious emissions;

Remark:

The notch filter is used for avoid the EUT fundamental carrier output power making the spectrum overload and the harmonic spurious brought by it.

When the EUT fundamental carrier is not enough to make the status, the notch filter could be not used.

5.2.3.1 Measurement Record

5.2.3.1.1 700MHz Lower ABC Band

5.2.3.1.1.1 700MHz Lower A LTE modulation

(1.1) Test for LTE 1.4MHz

(1.1.1) Lower Edge

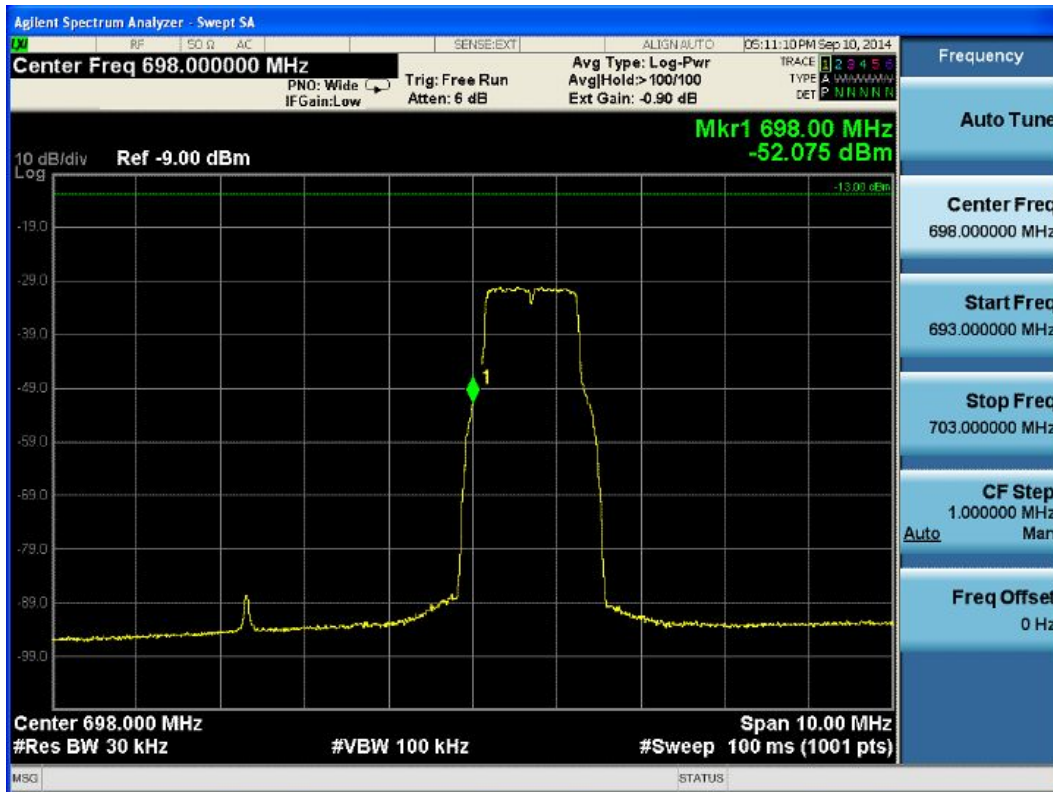

(1.1.2) Upper Edge

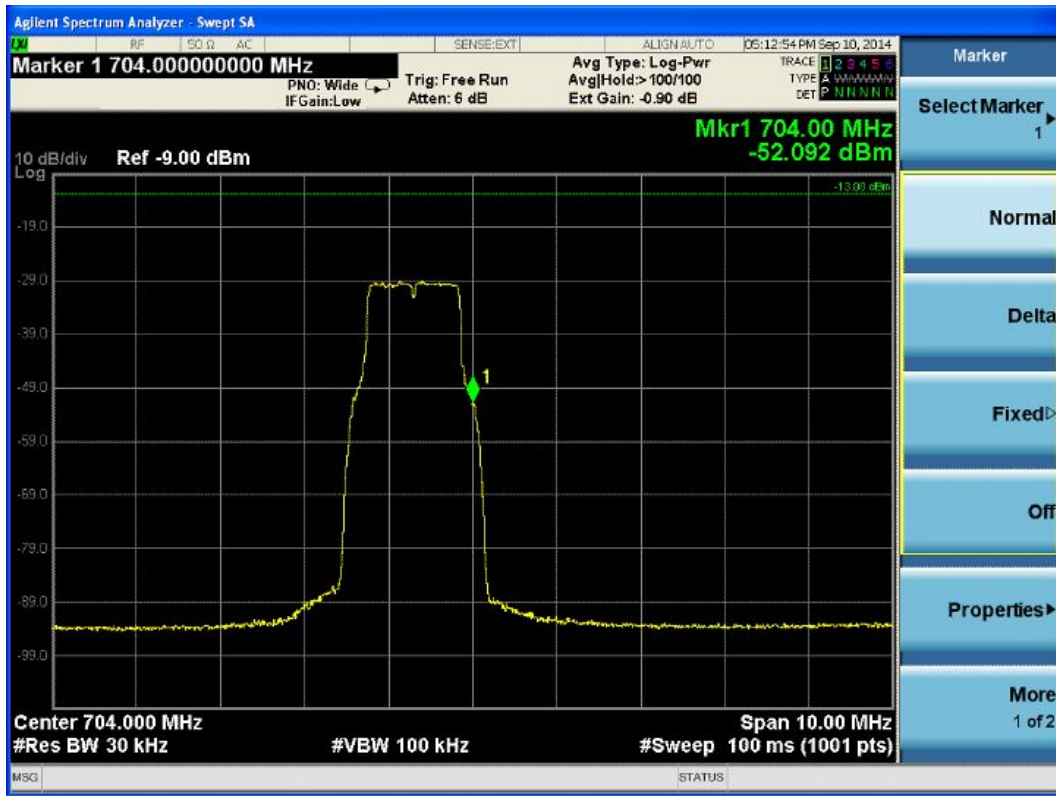

(1.2) Test for LTE 3MHz

(1.2.1) Lower Edge

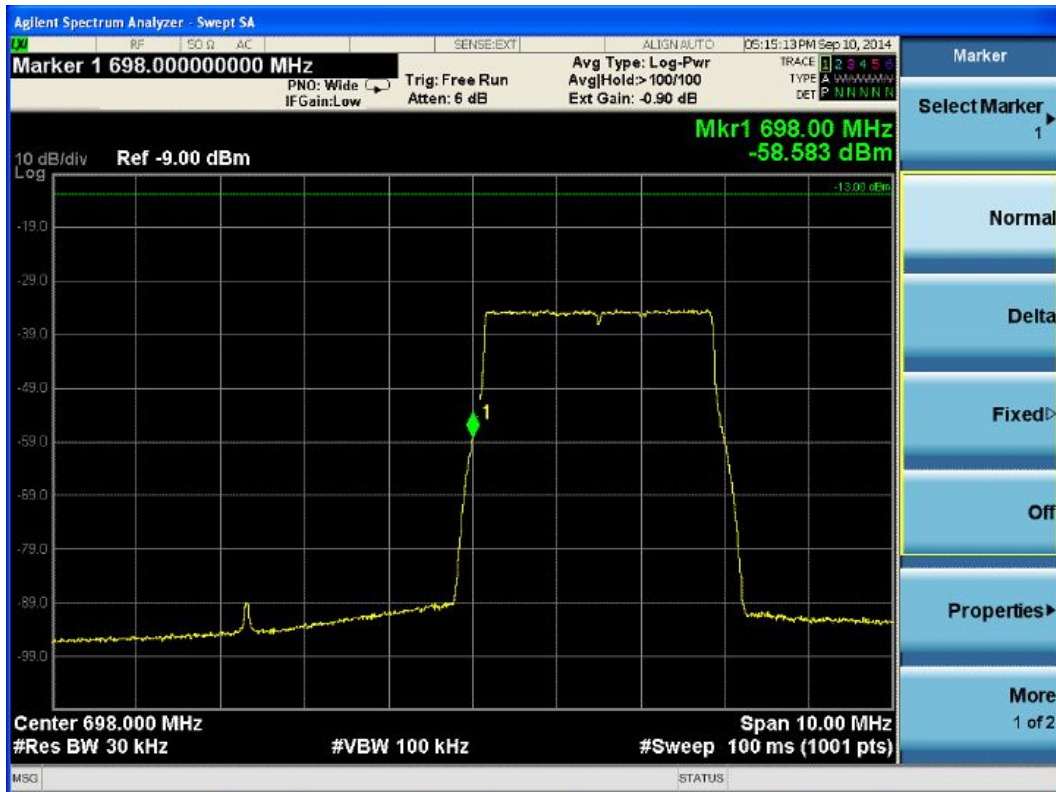

(1.2.2) Upper Edge

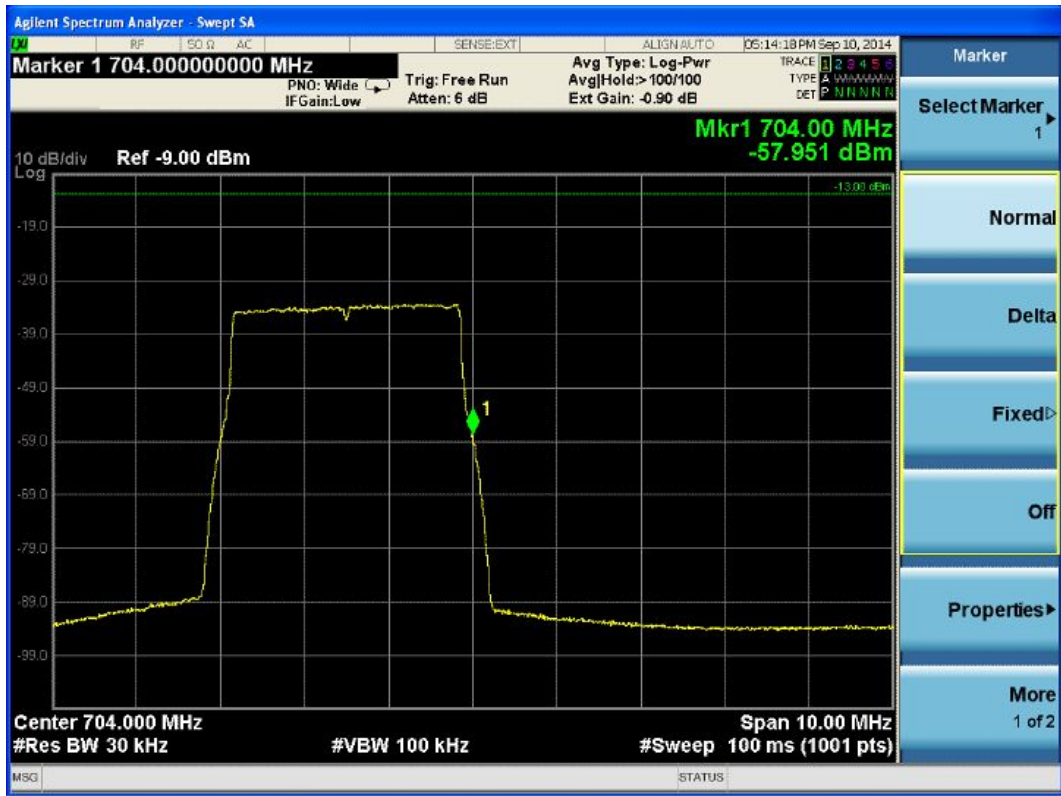

(1.3) Test for LTE 5MHz

(1.3.1) Lower Edge

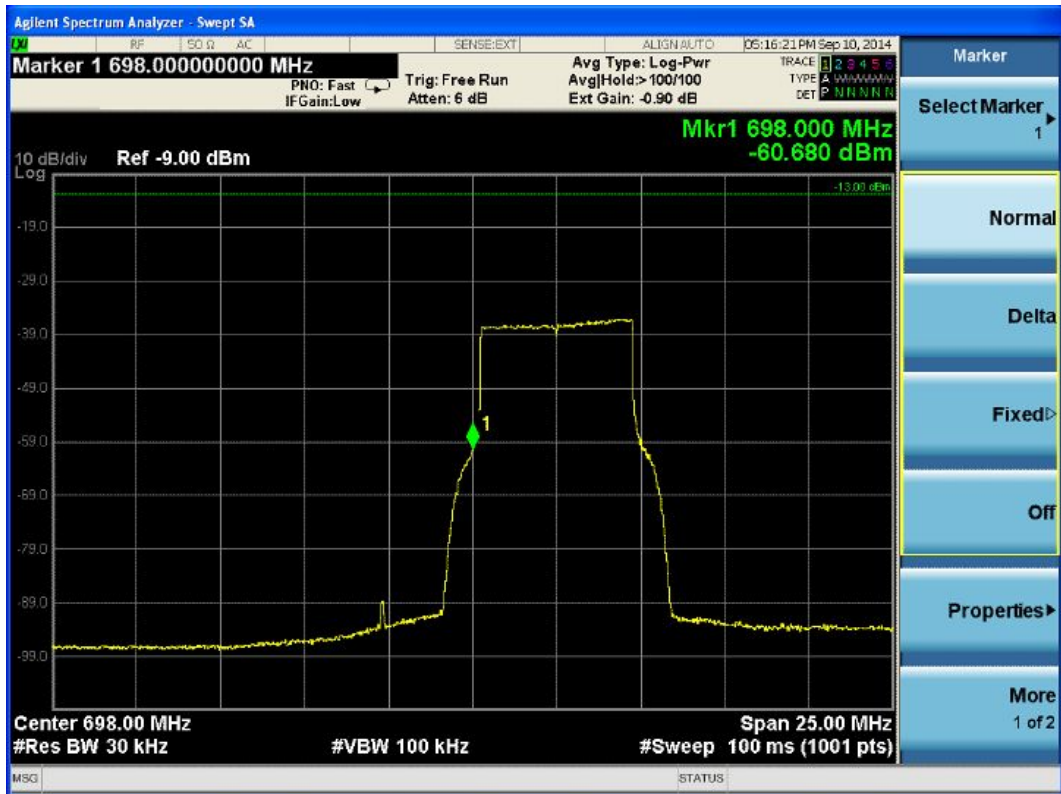

(1.3.2) Upper Edge

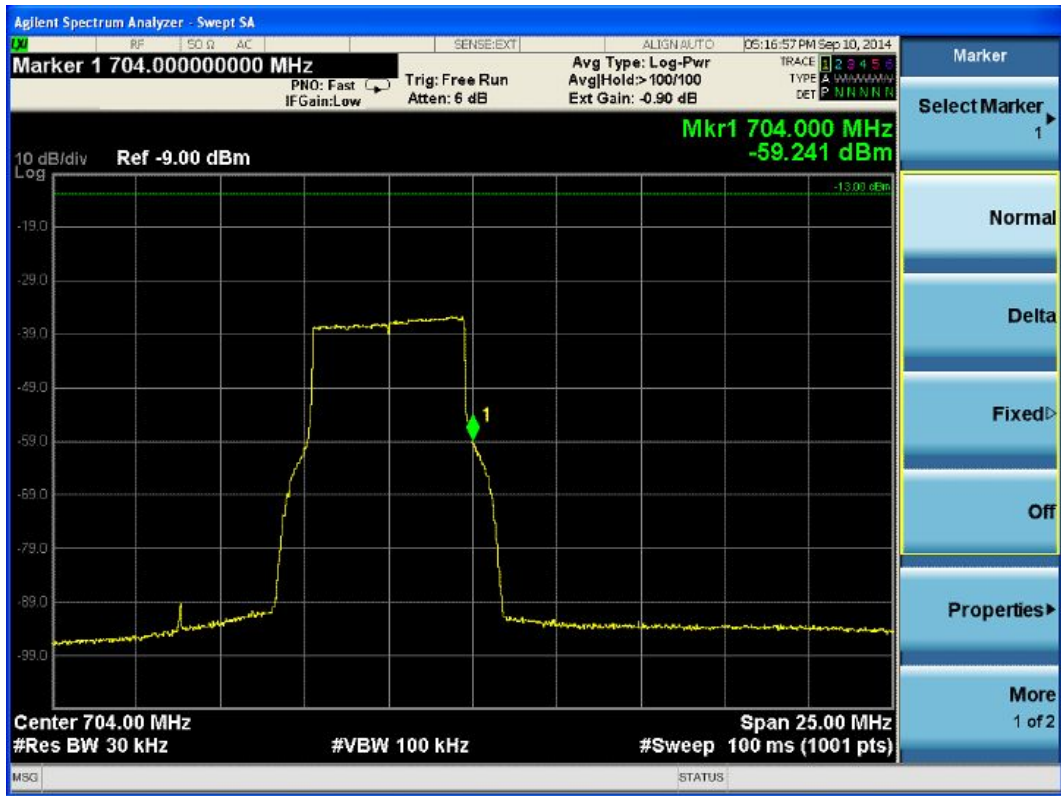

5.2.3.1.1.2 700MHz Lower B LTE modulation

(1.1) Test for LTE 1.4MHz

(1.1.1) Lower Edge

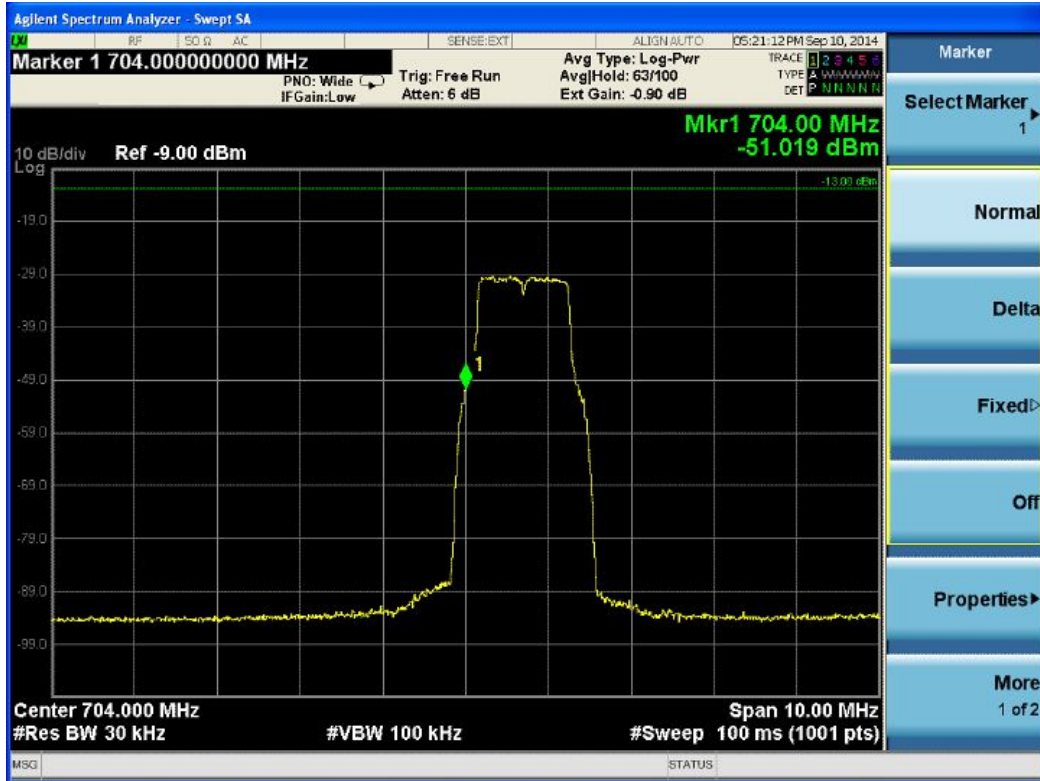

(1.1.2) Upper Edge

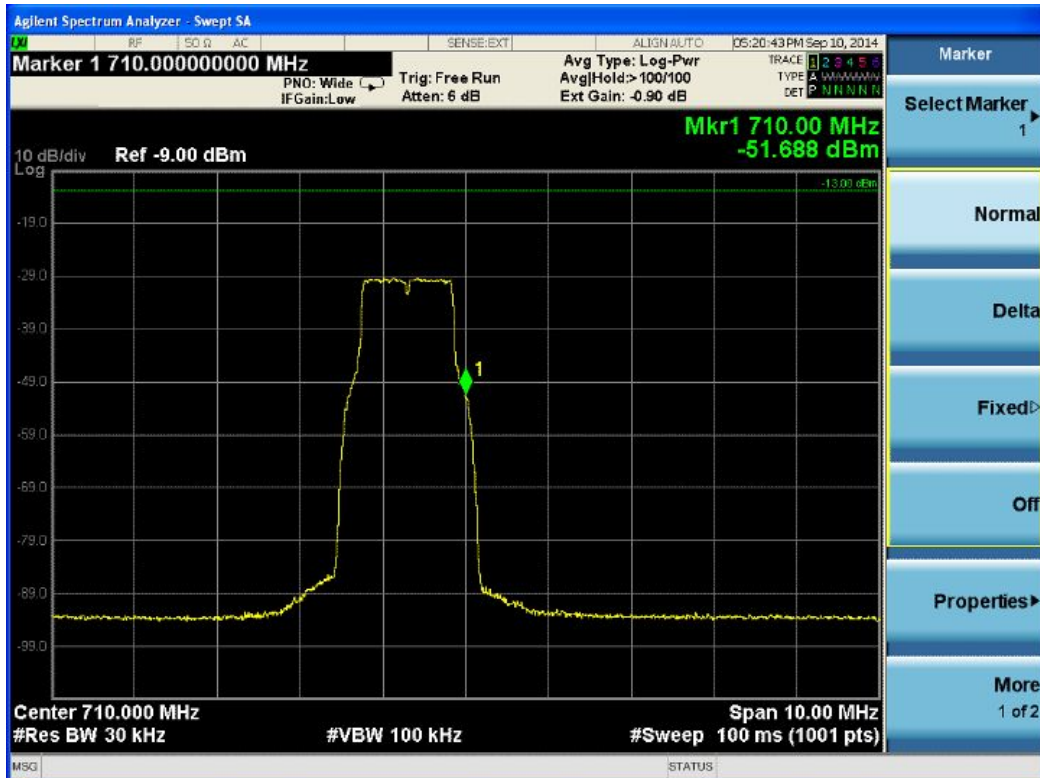

(1.2) Test for LTE 3MHz

(1.2.1) Lower Edge

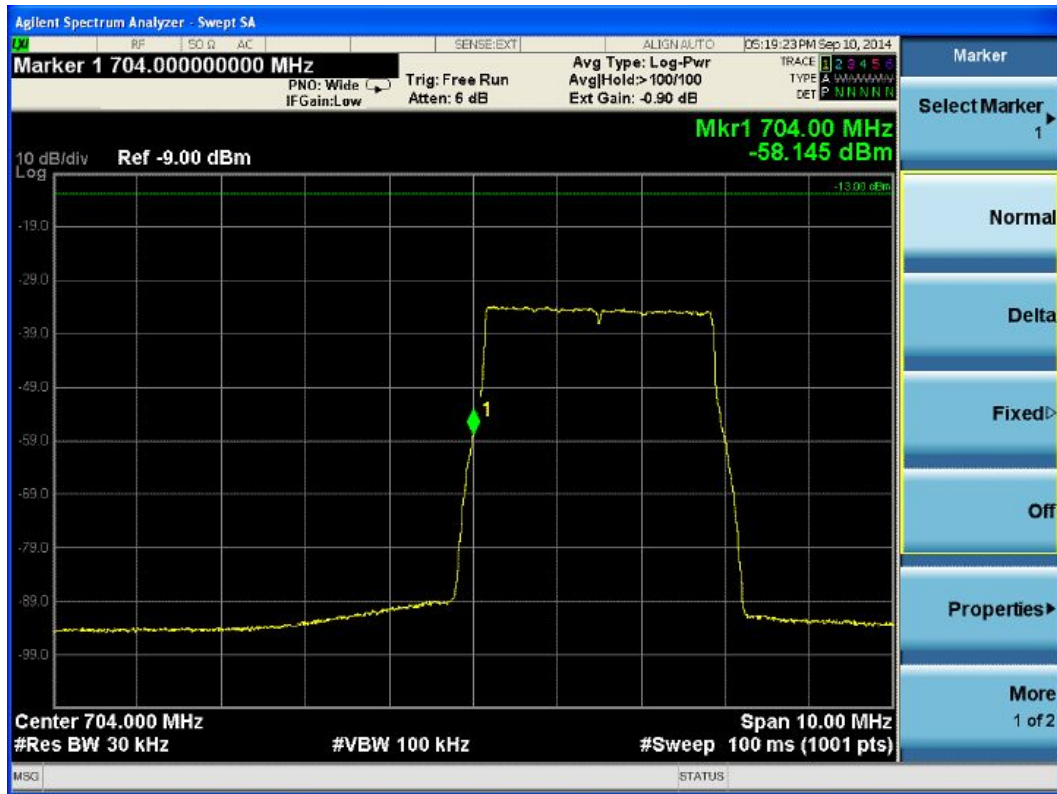

(1.2.2) Upper Edge

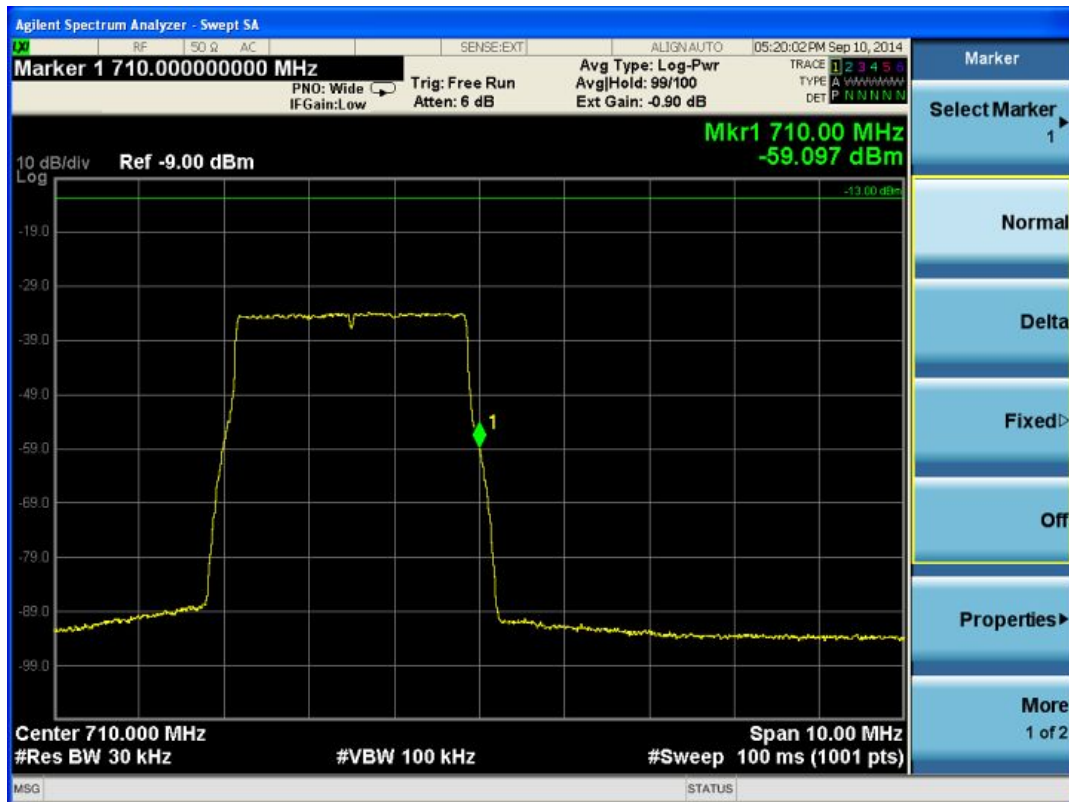

(1.3) Test for LTE 5 MHz

(1.3.1) Lower Edge

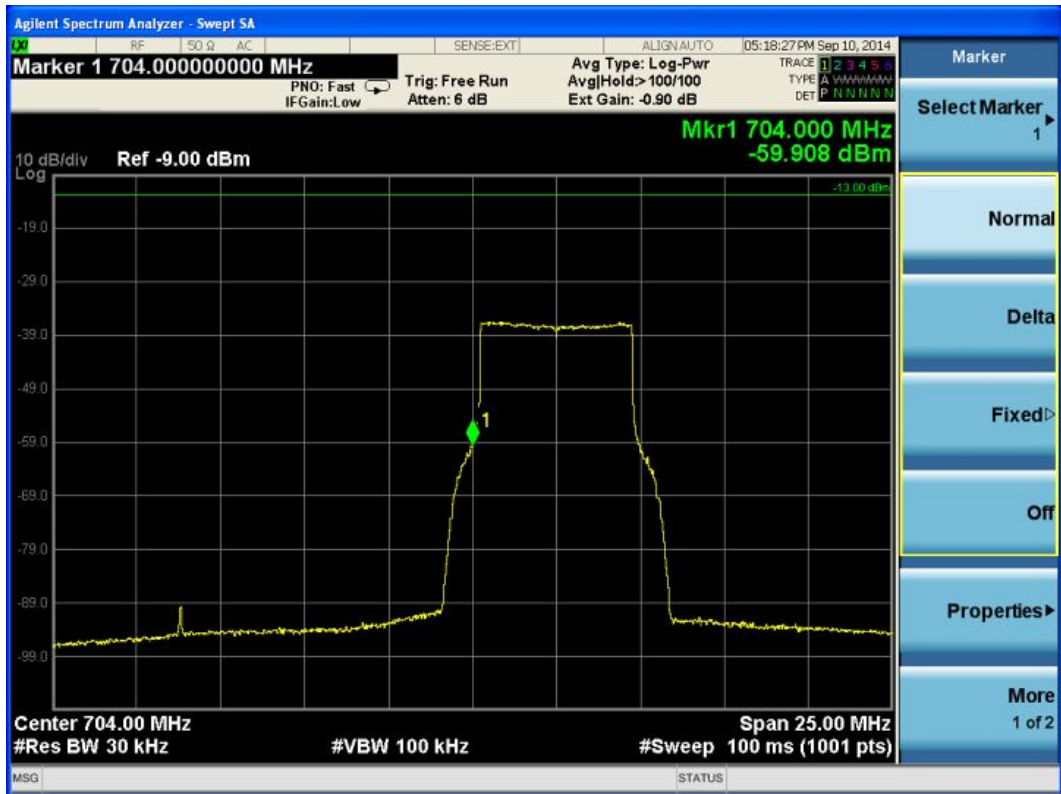

(1.3.2) Upper Edge

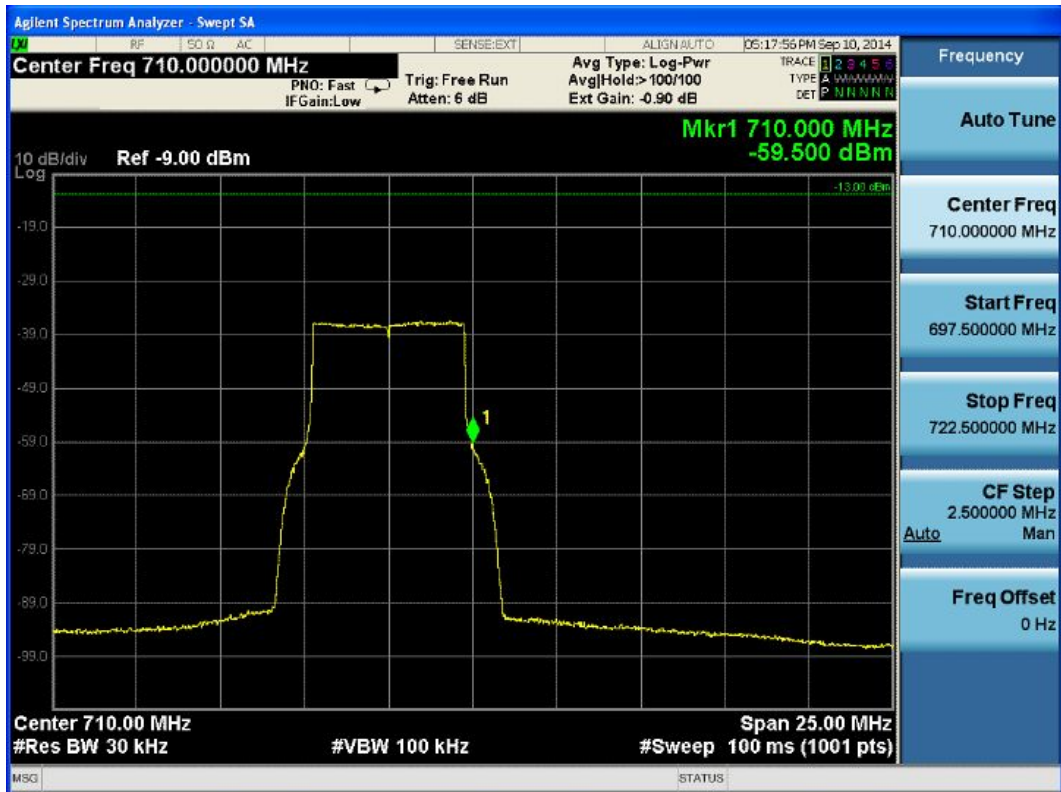

5.2.3.1.1.3 700MHz Lower C LTE modulation

(1.1) Test for LTE 1.4MHz

(1.1.1) Lower Edge

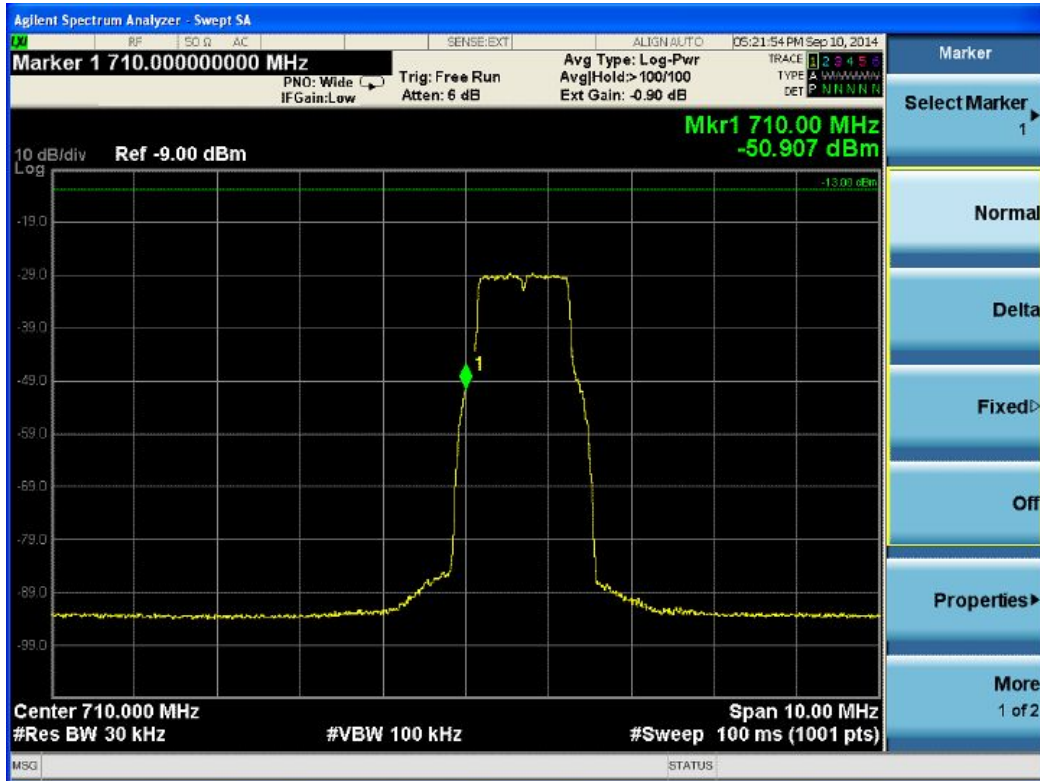

(1.1.2) Upper Edge

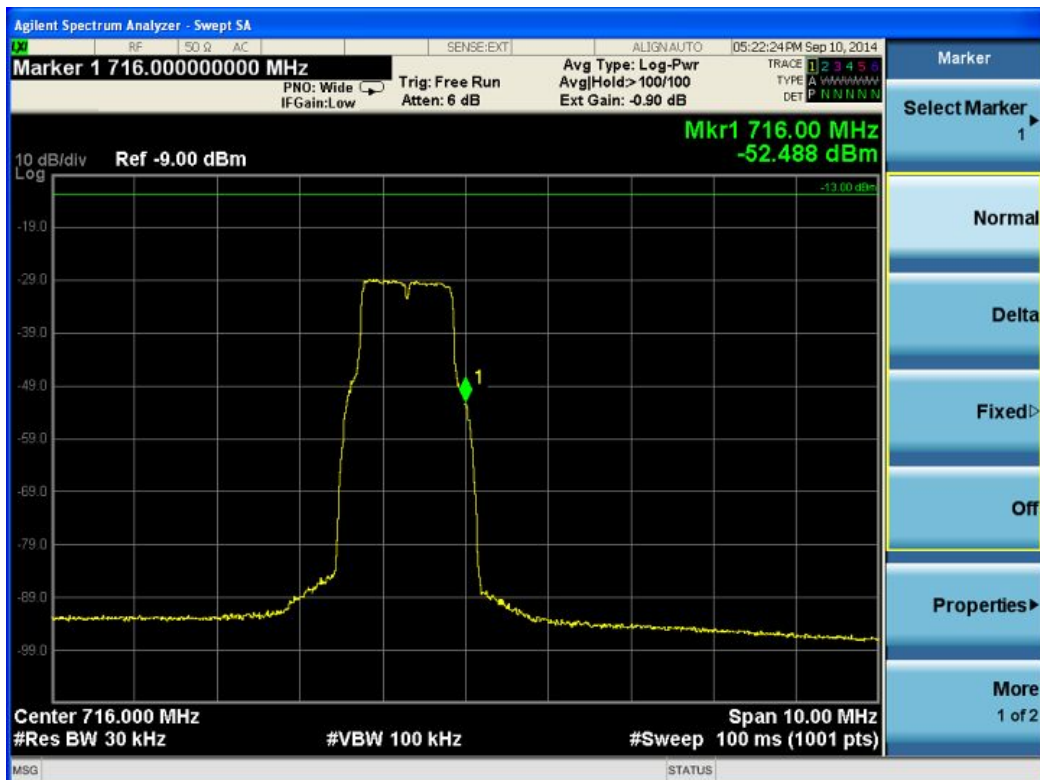

(1.2) Test for LTE 3 MHz

(1.2.1) Lower Edge

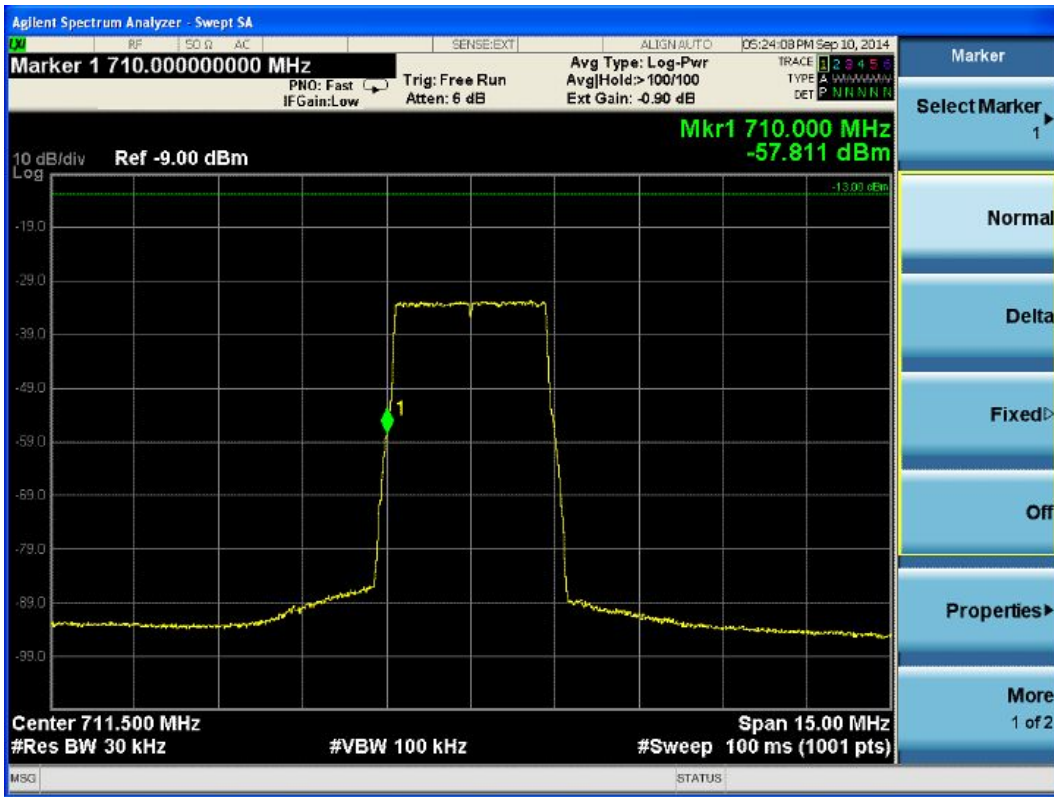

(1.2.2) Upper Edge

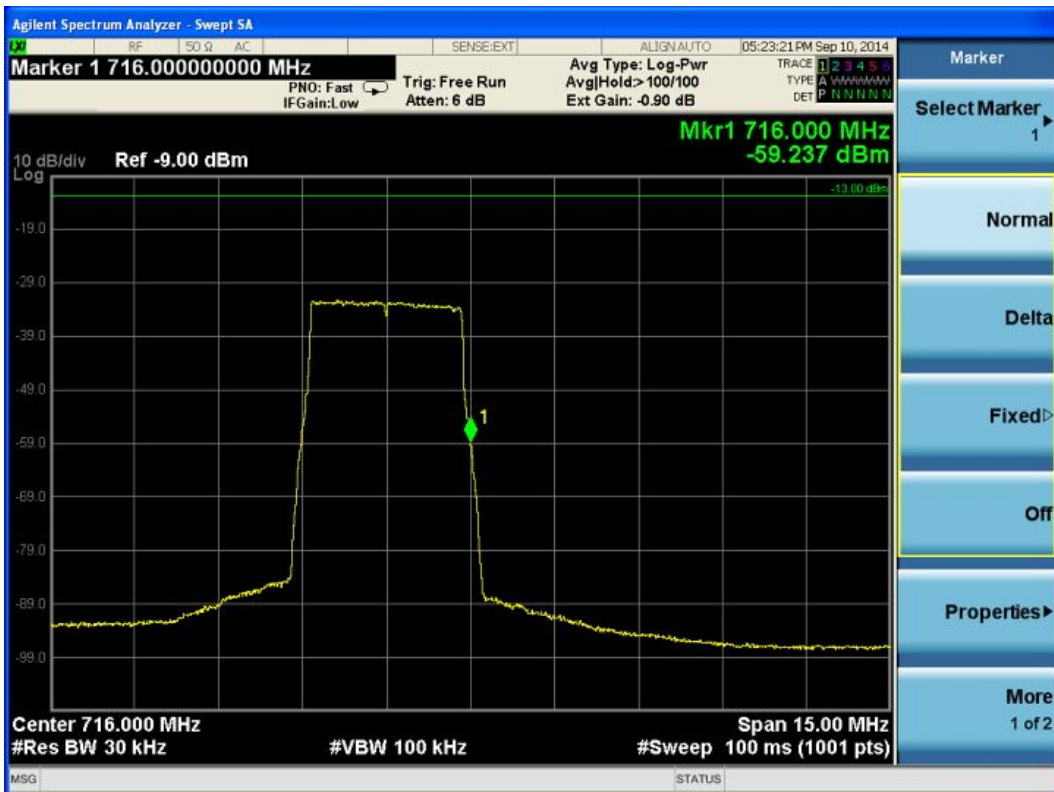

(1.3) Test for LTE 5 MHz

(1.3.1) Lower Edge

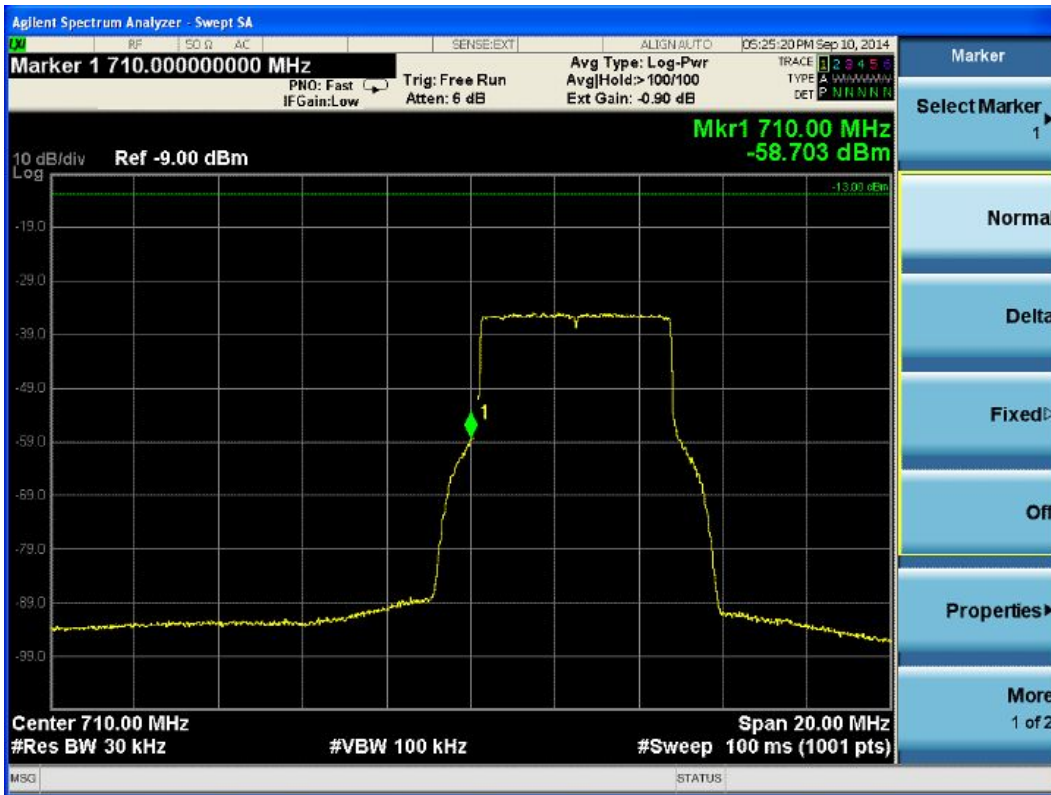

(1.3.2) Upper Edge

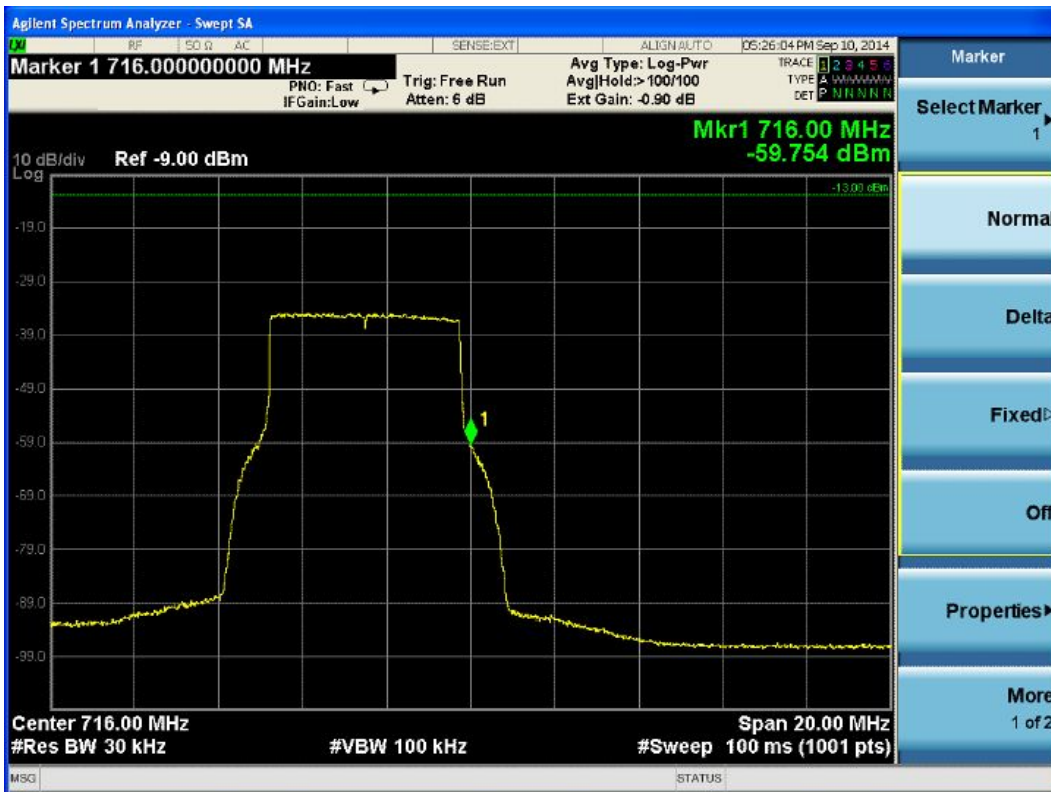

5.2.3.1.1.4 700MHz Lower ABC LTE modulation

(1.1) Test for LTE 10MHz

(1.1.1) Lower Edge

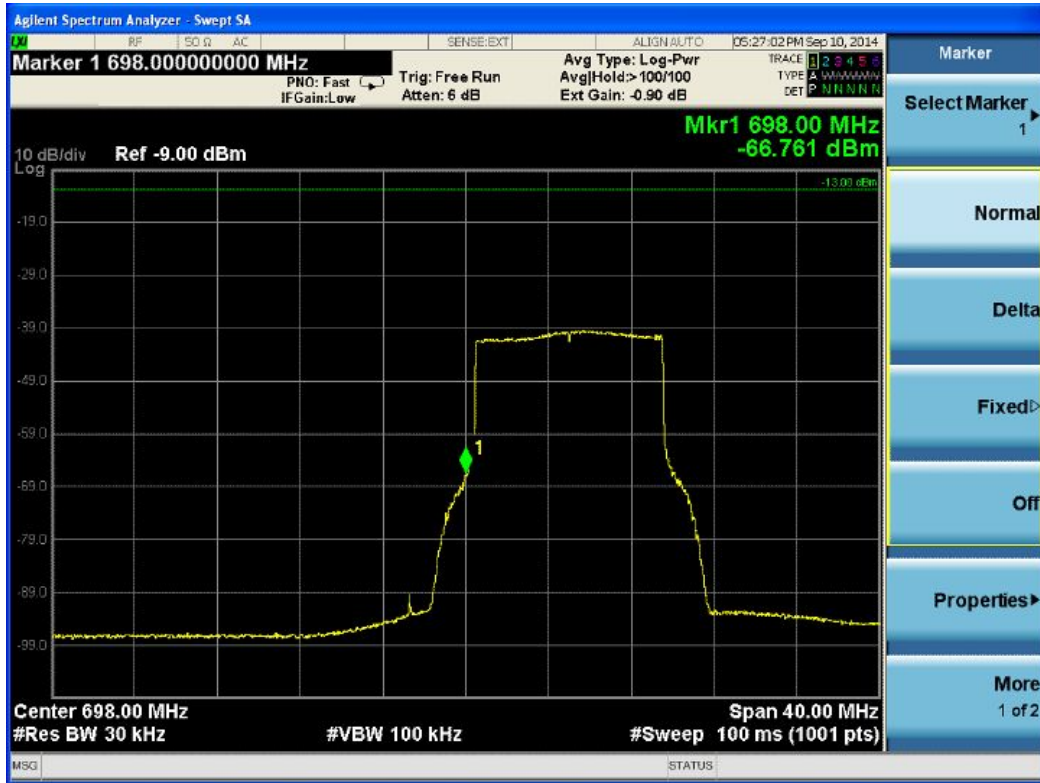

(1.1.2) Upper Edge

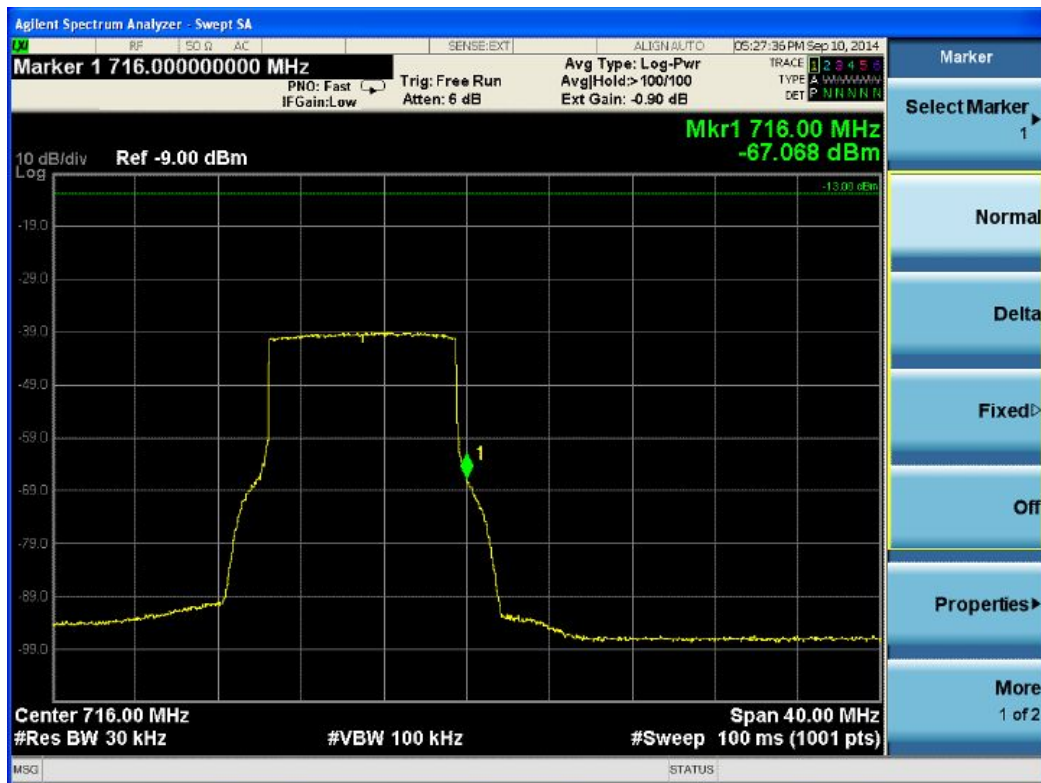

(1.2) Test for LTE 15MHz

(1.2.1) Lower Edge



(1.2.2) Upper Edge

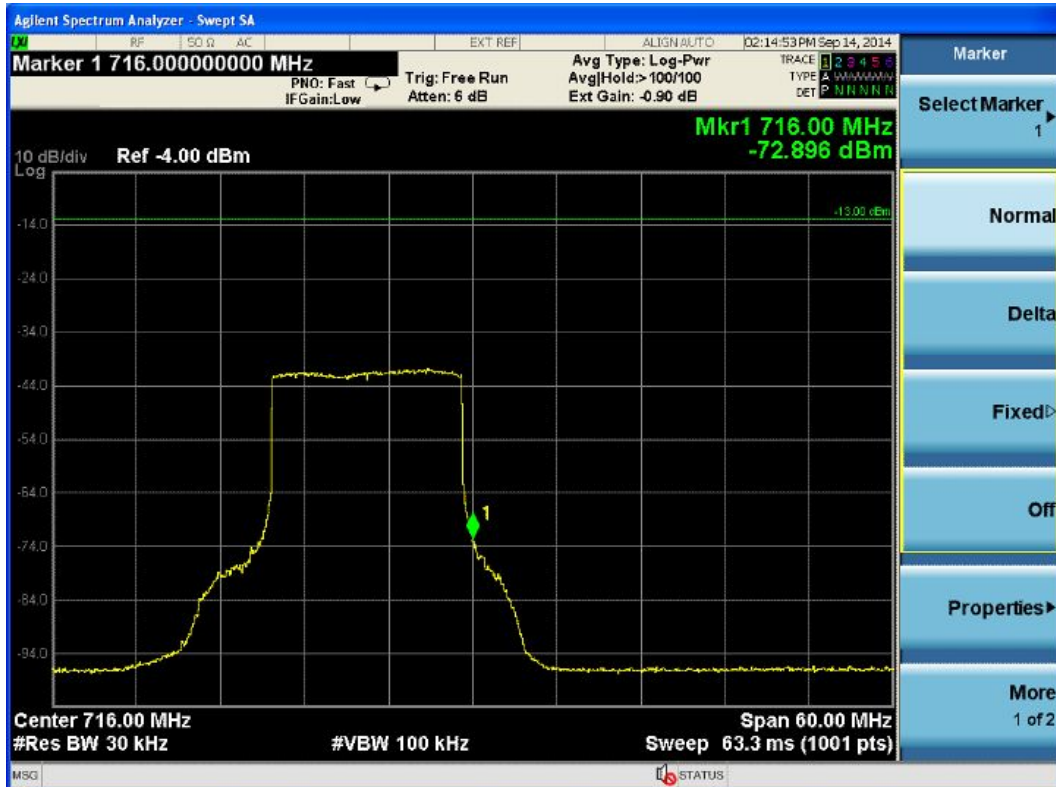

5.3.3.1.2 700MHz Upper C Band

(1.1) Test for LTE 1.4MHz

(1.1.1) Lower Edge

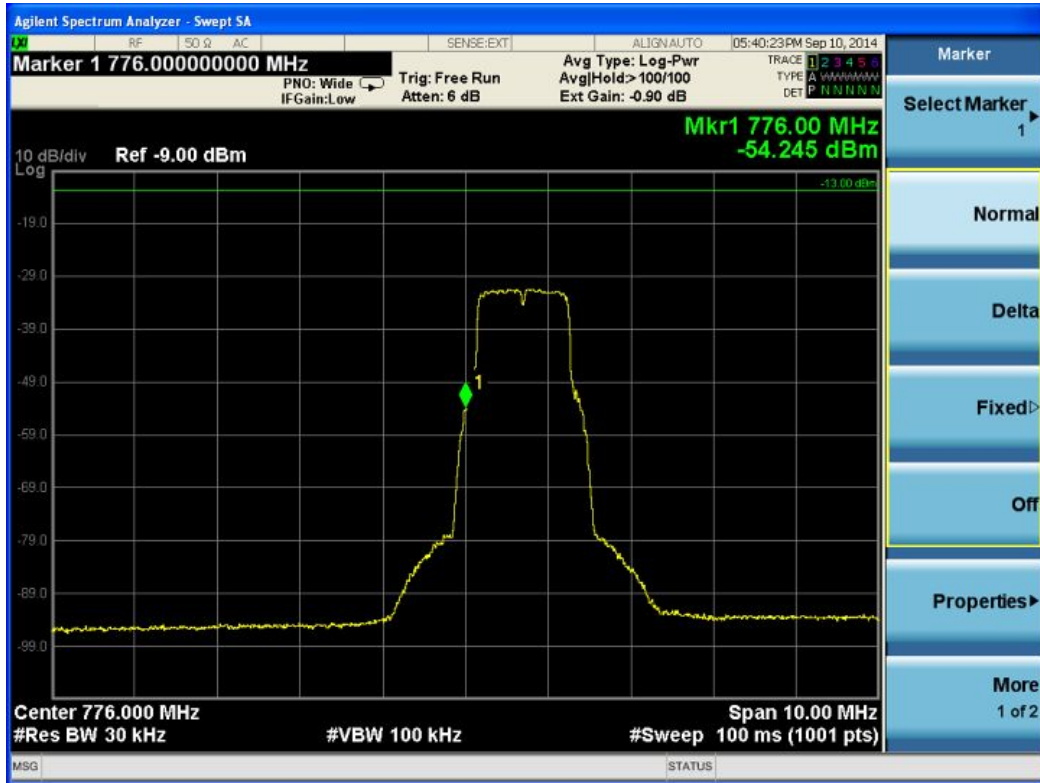

(1.1.2) Upper Edge

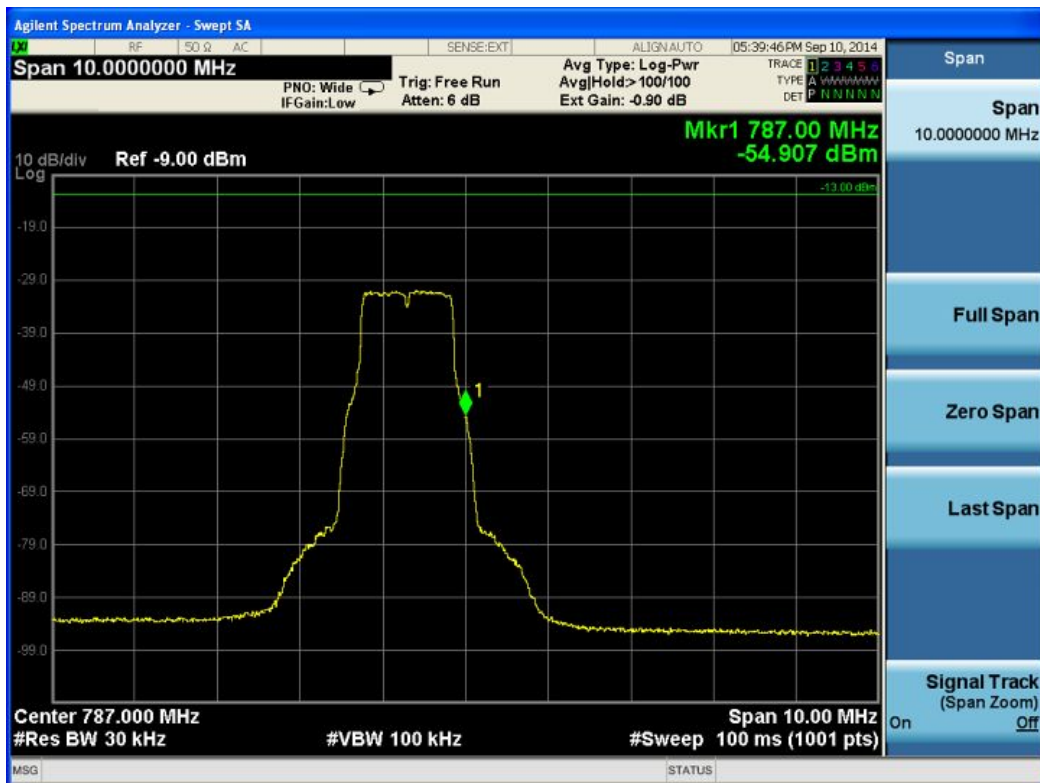

(1.2) Test for LTE 3MHz

(1.2.1) Lower Edge

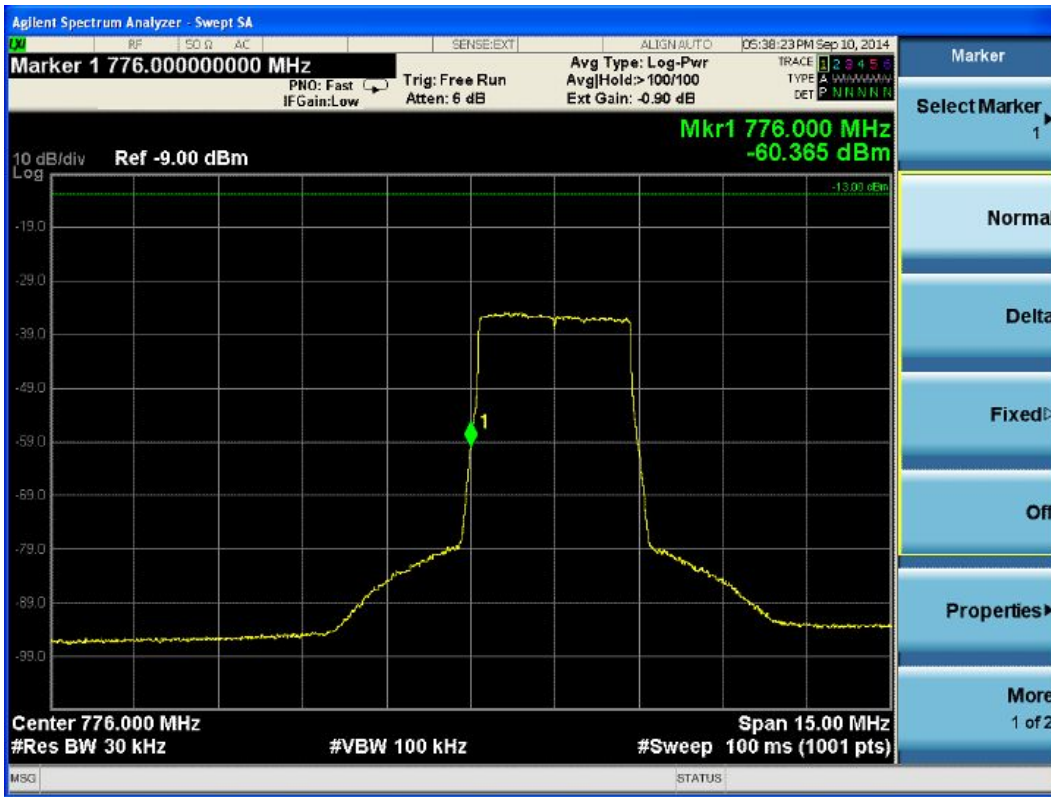

(1.2.2) Upper Edge

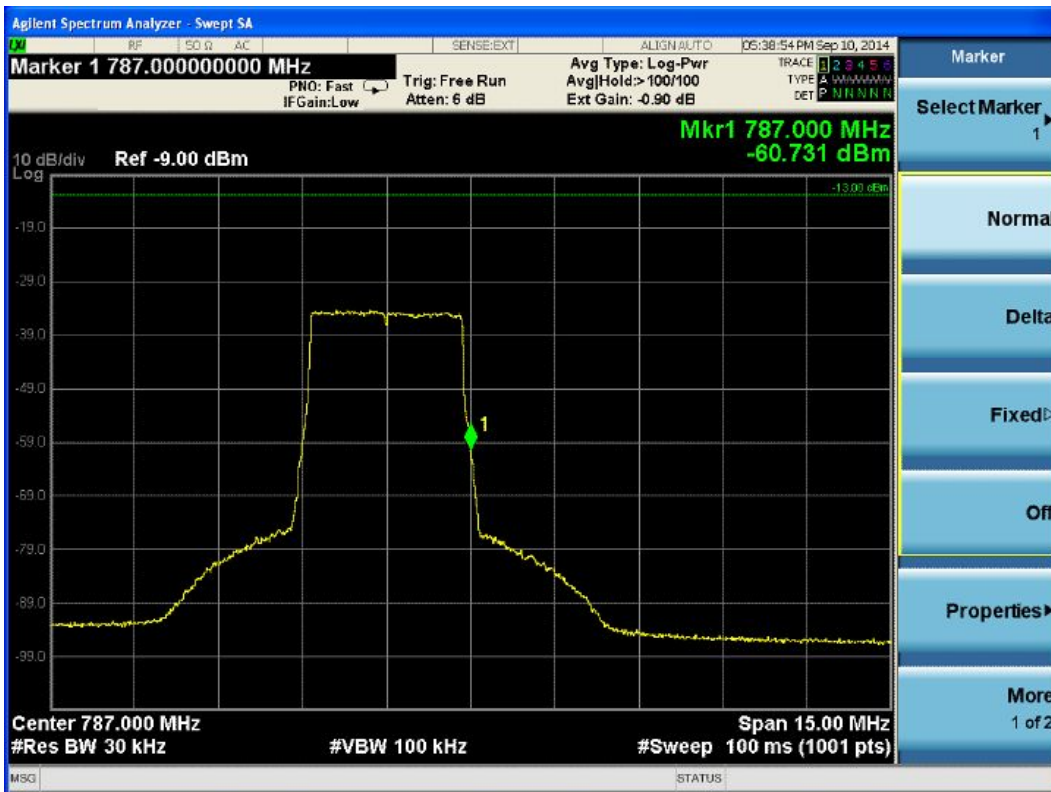

(1.3) Test for LTE 5MHz

(1.3.1) Lower Edge



(1.3.2) Upper Edge



(1.4) Test for LTE 10MHz

(1.4.1) Lower Edge



(1.4.2) Upper Edge

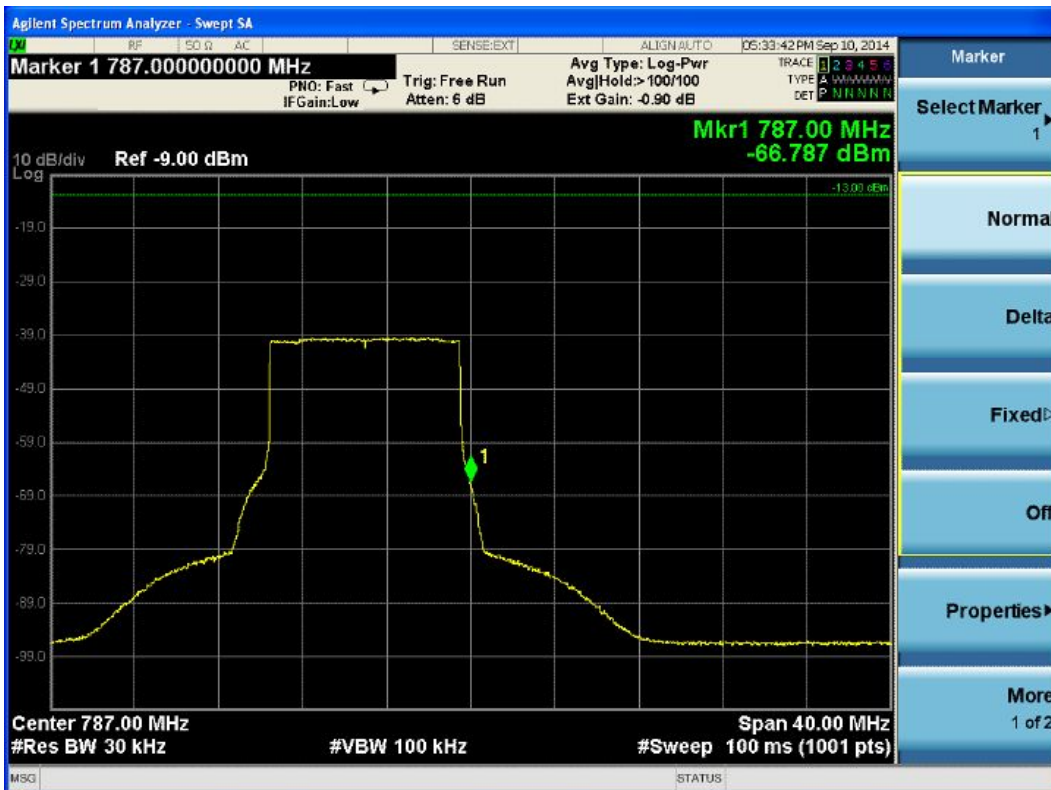

5.2.3.1.3 800MHz Band

(1) LTE modulation

(1.1) Test for LTE 1.4MHz

(1.1.1) Lower Edge

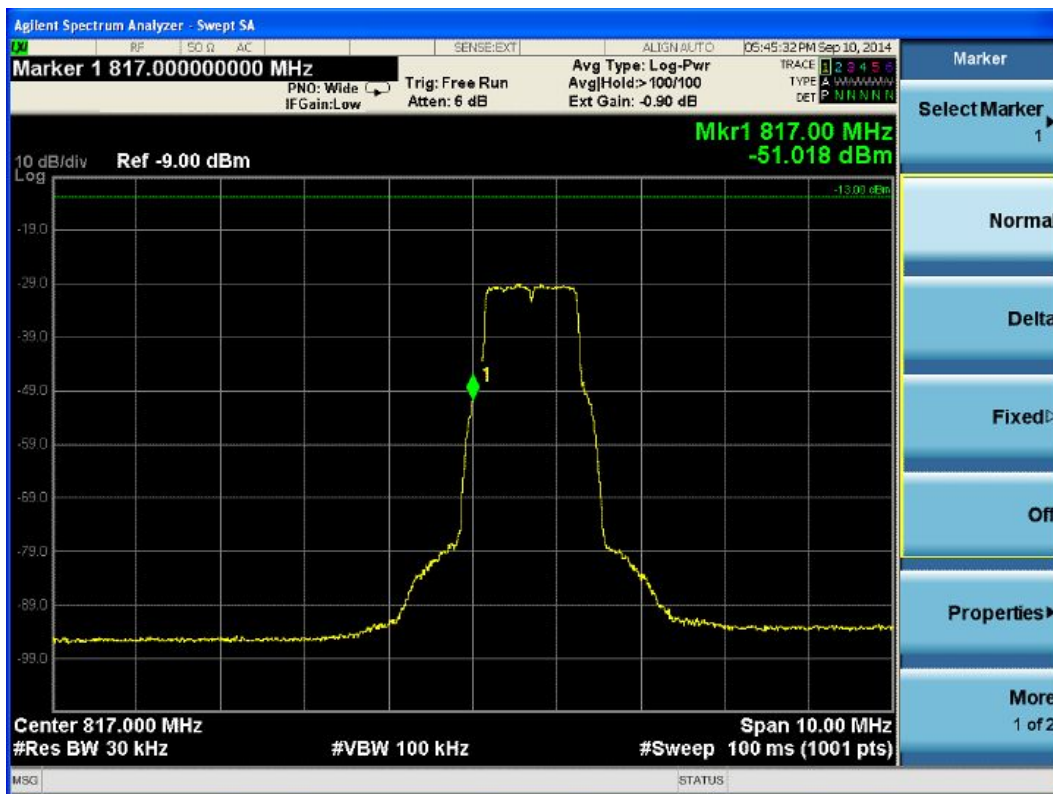

(1.1.2) Upper Edge

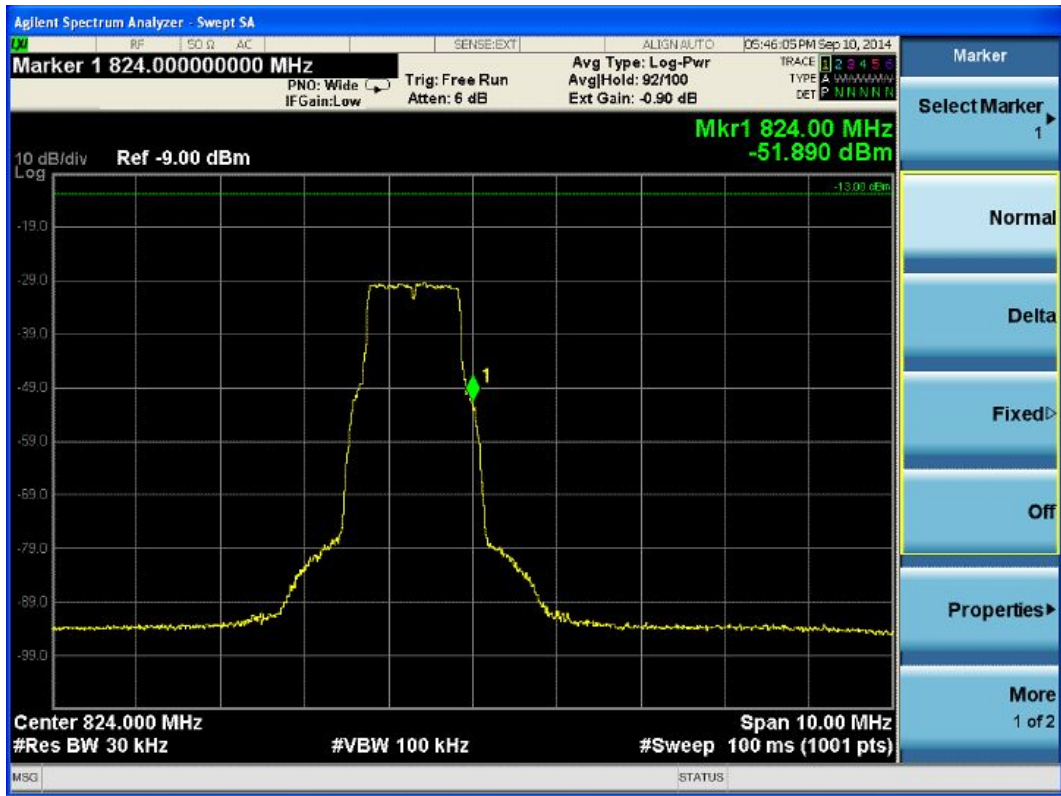

(1.2) Test for LTE 3MHz

(1.2.1) Lower Edge

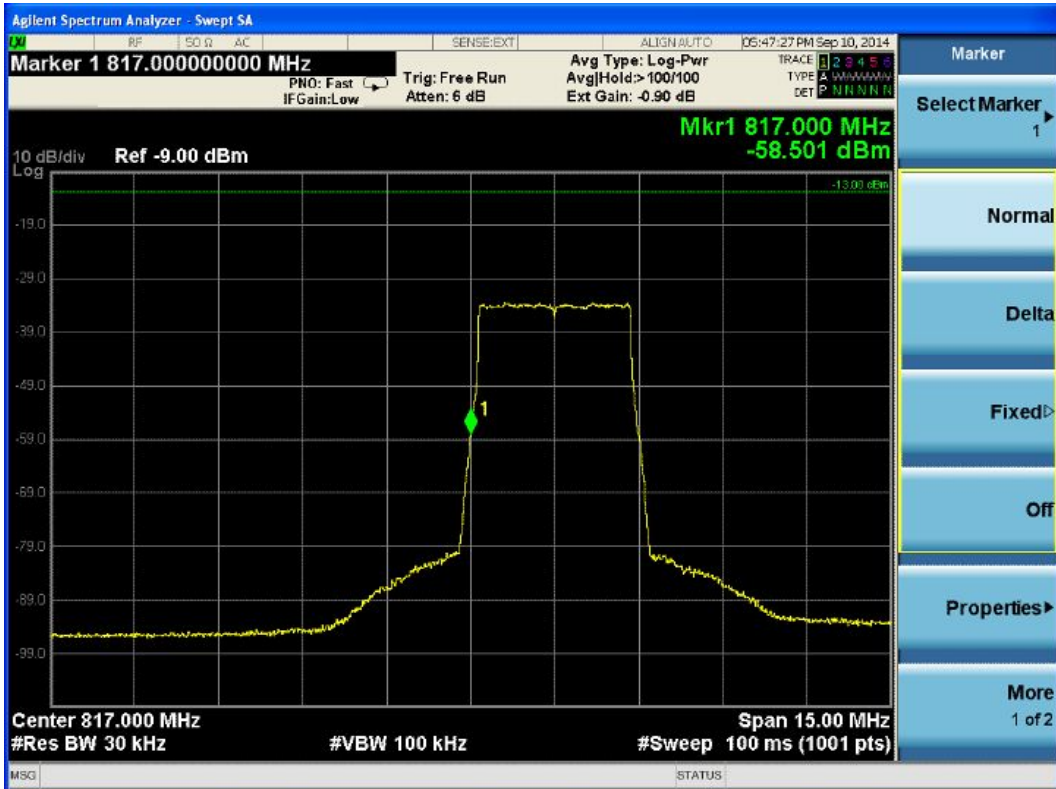

(1.2.2) Upper Edge

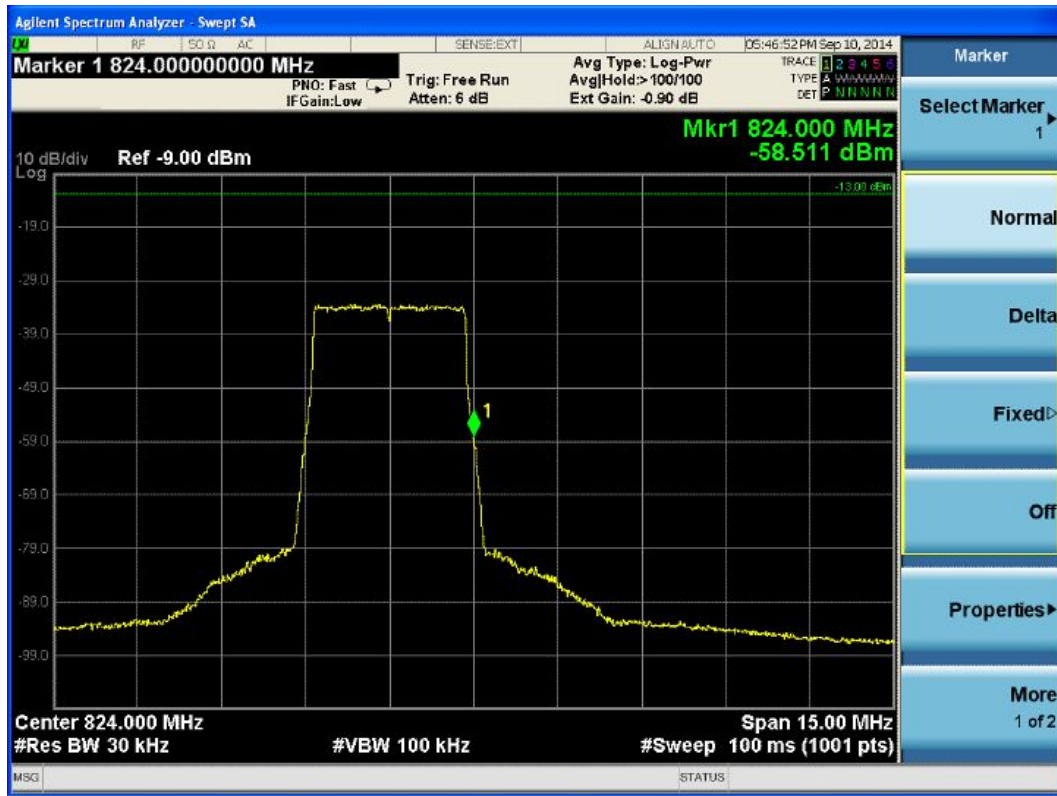

(1.3) Test for LTE 5MHz

(1.3.1) Lower Edge

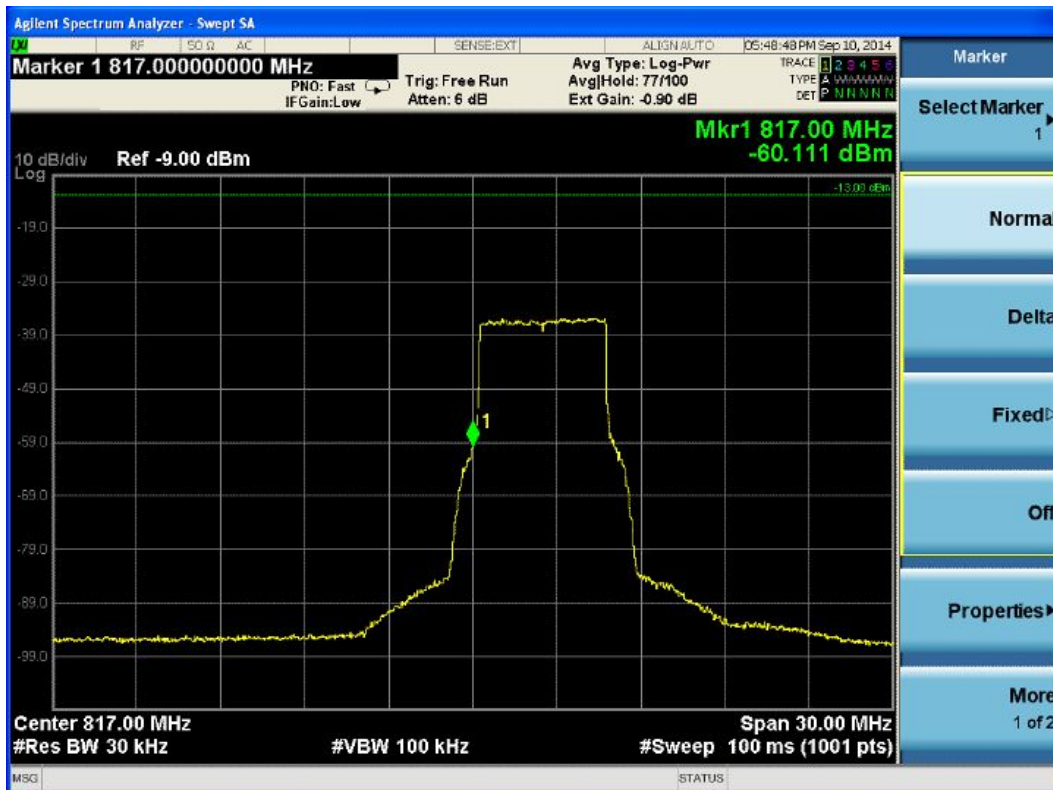

(1.3.2) Upper Edge

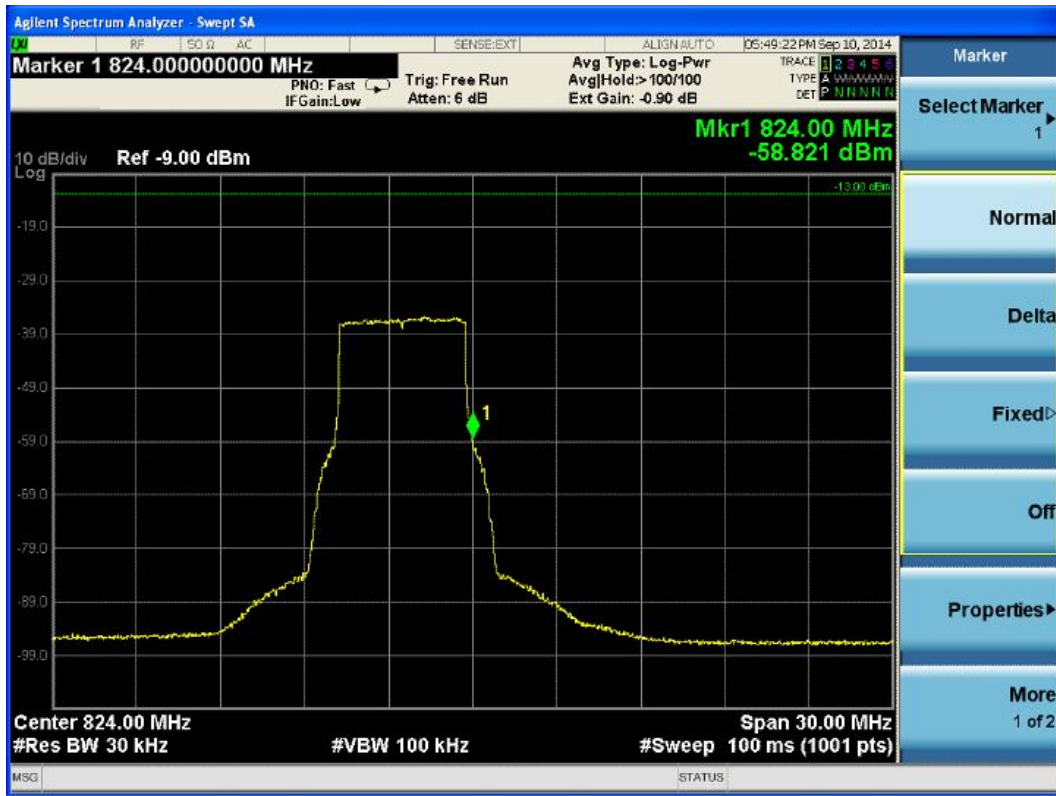

(2) CDMA modulation

(2.1.1) Lower Edge

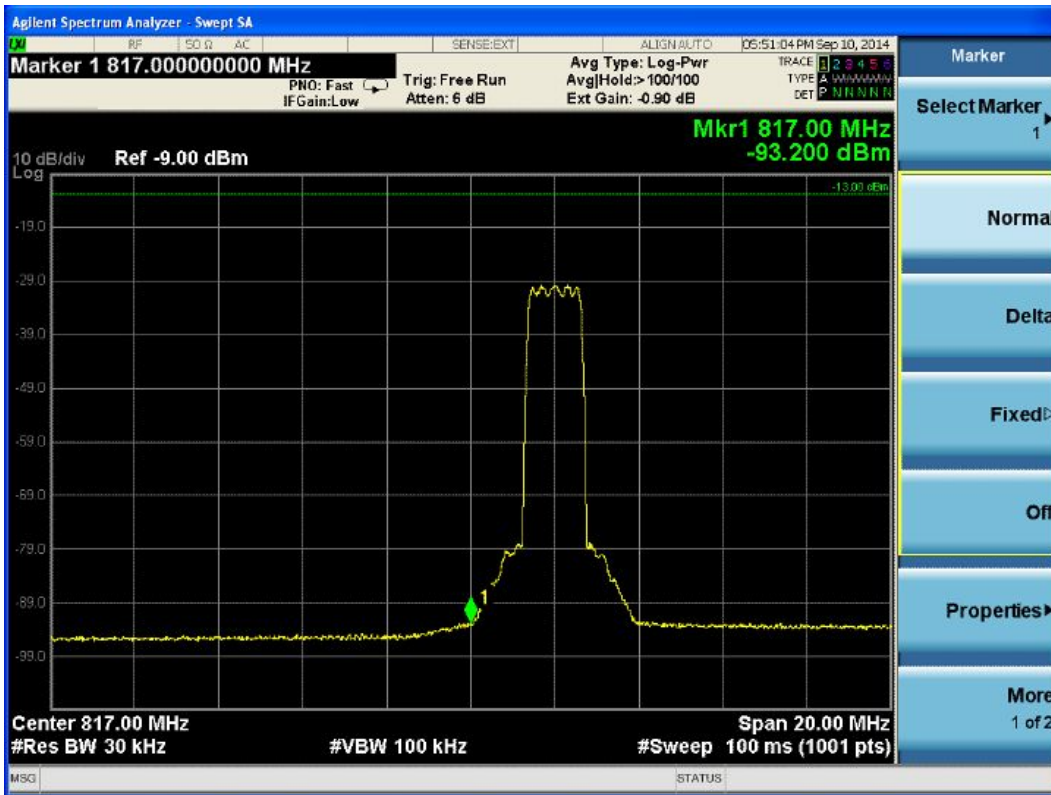

(2.1.2) Upper Edge

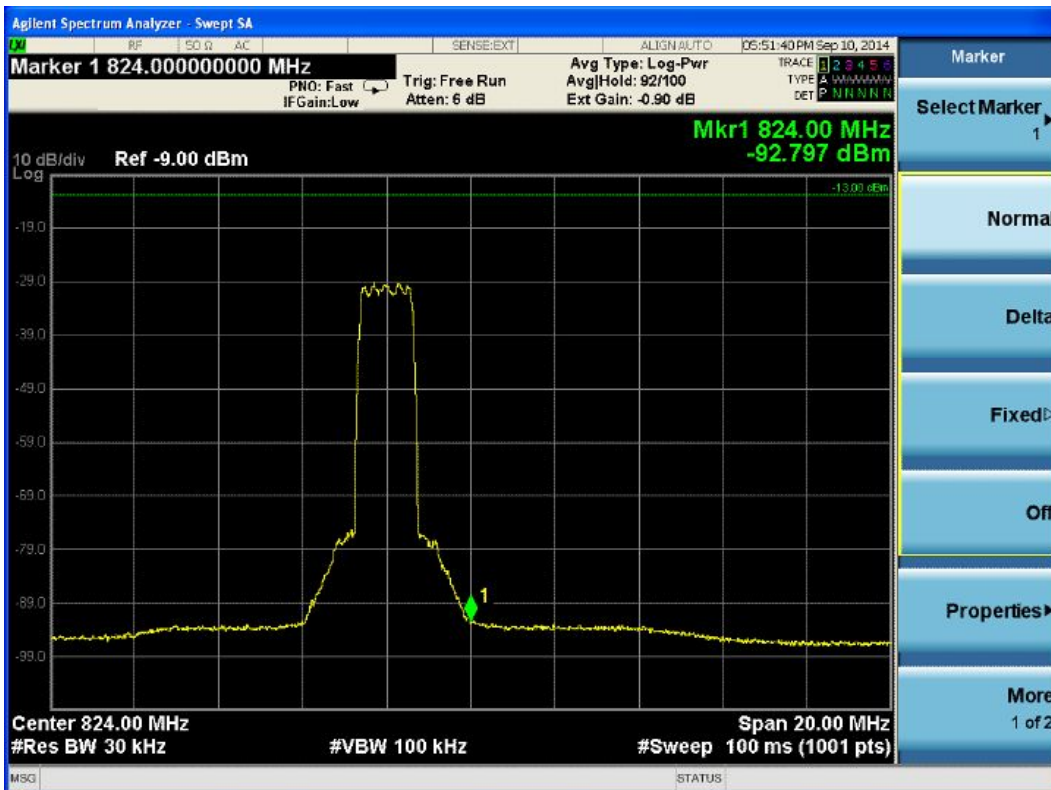

5.2.3.1.4 850MHz Band

(1) LTE modulation

(1.1) Test for LTE 1.4MHz

(1.1.1) Lower Edge

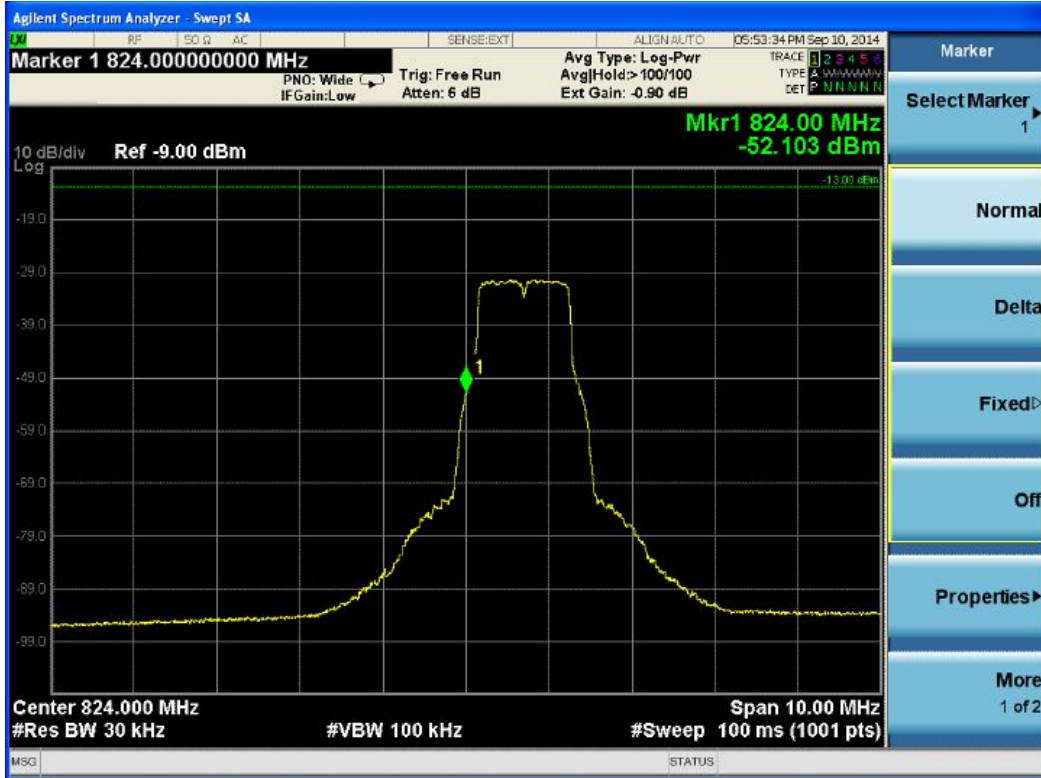

(1.1.2) Upper Edge

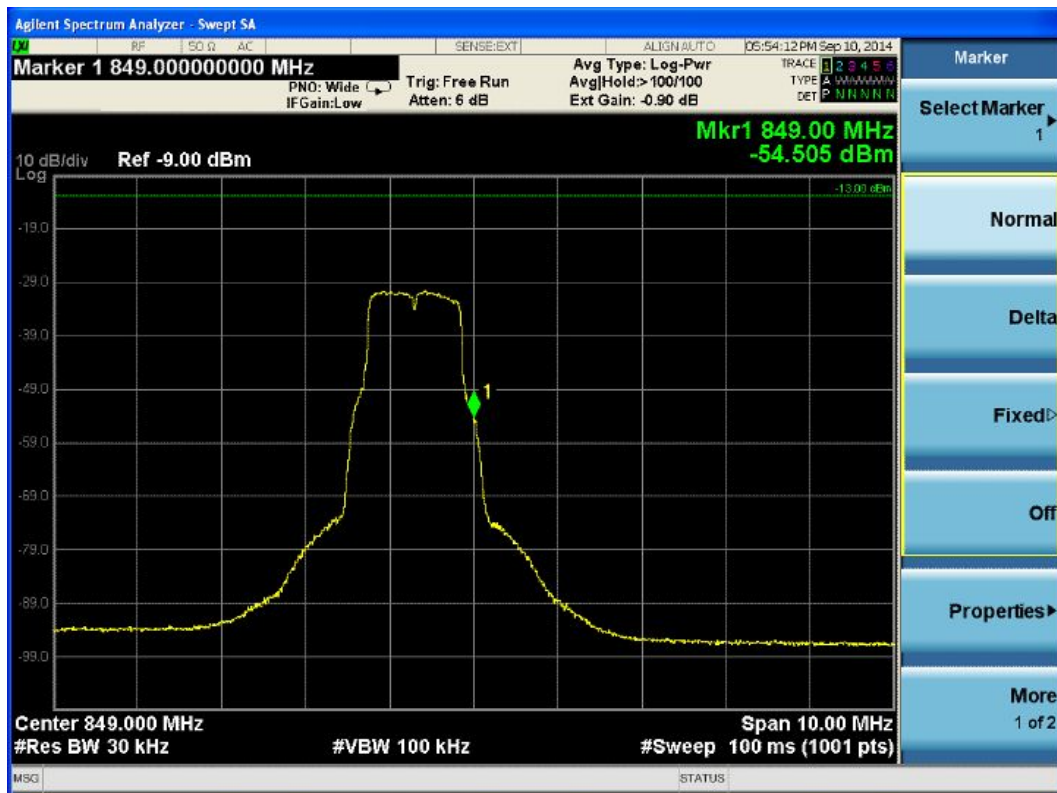

(1.2) Test for LTE 3MHz

(1.2.1) Lower Edge

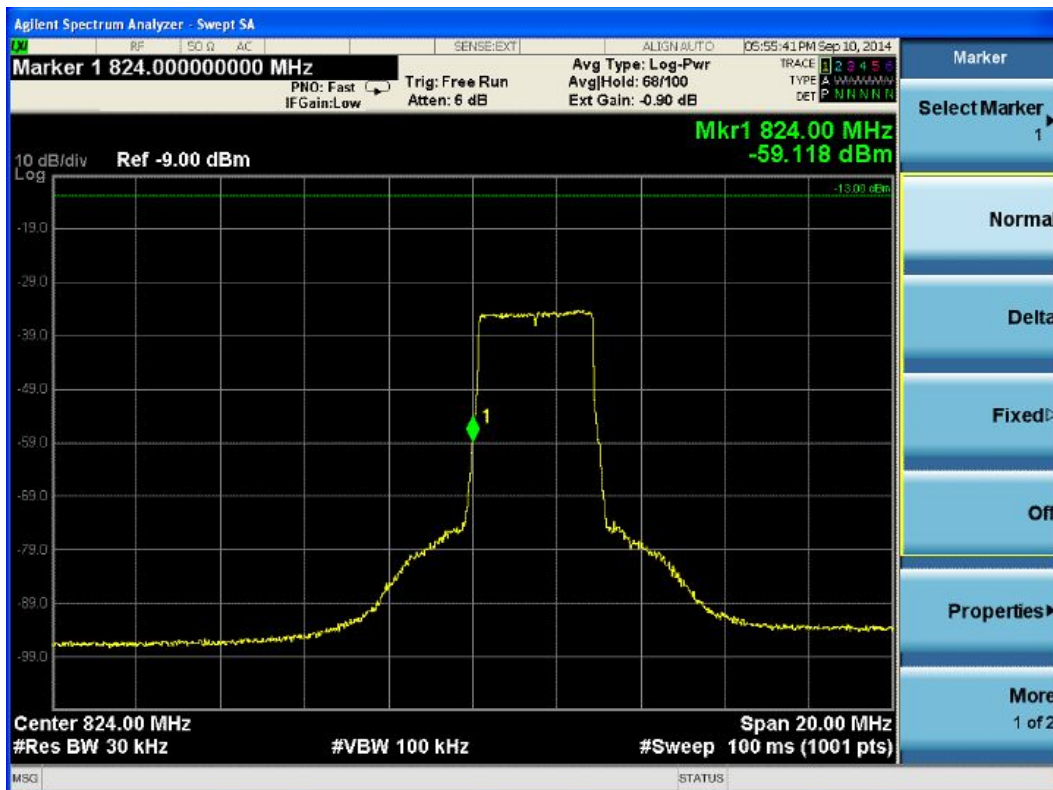

(1.2.2) Upper Edge

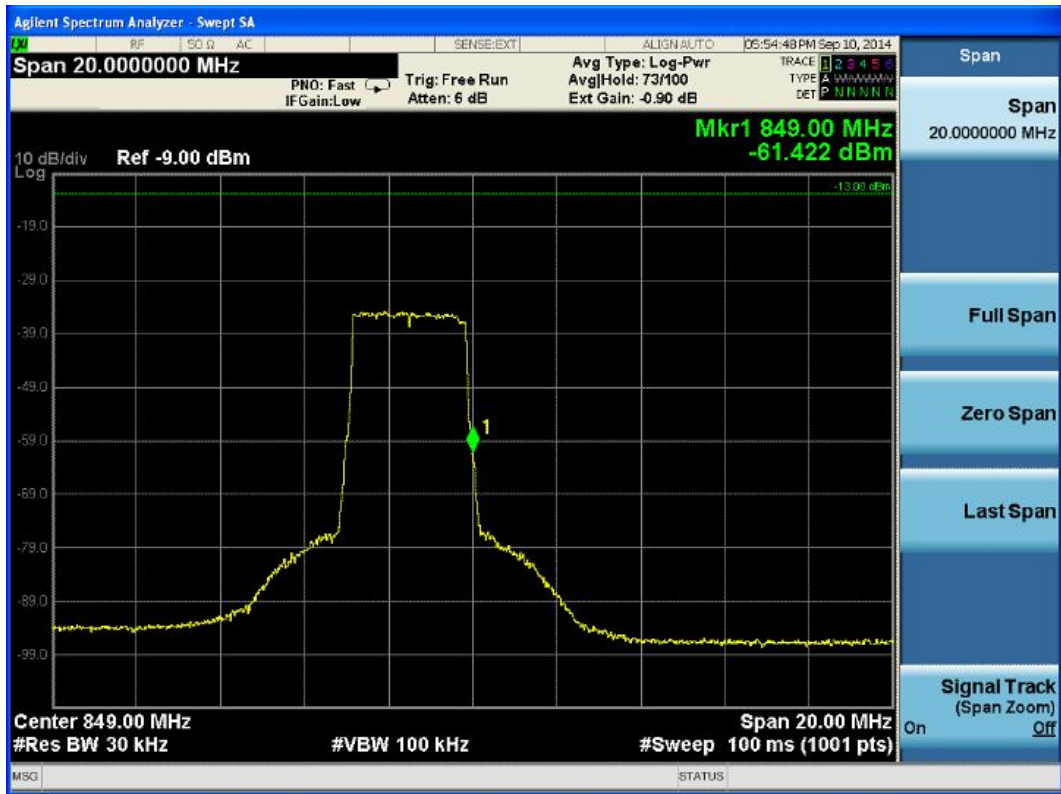

(1.3) Test for LTE 5MHz

(1.3.1) Lower Edge

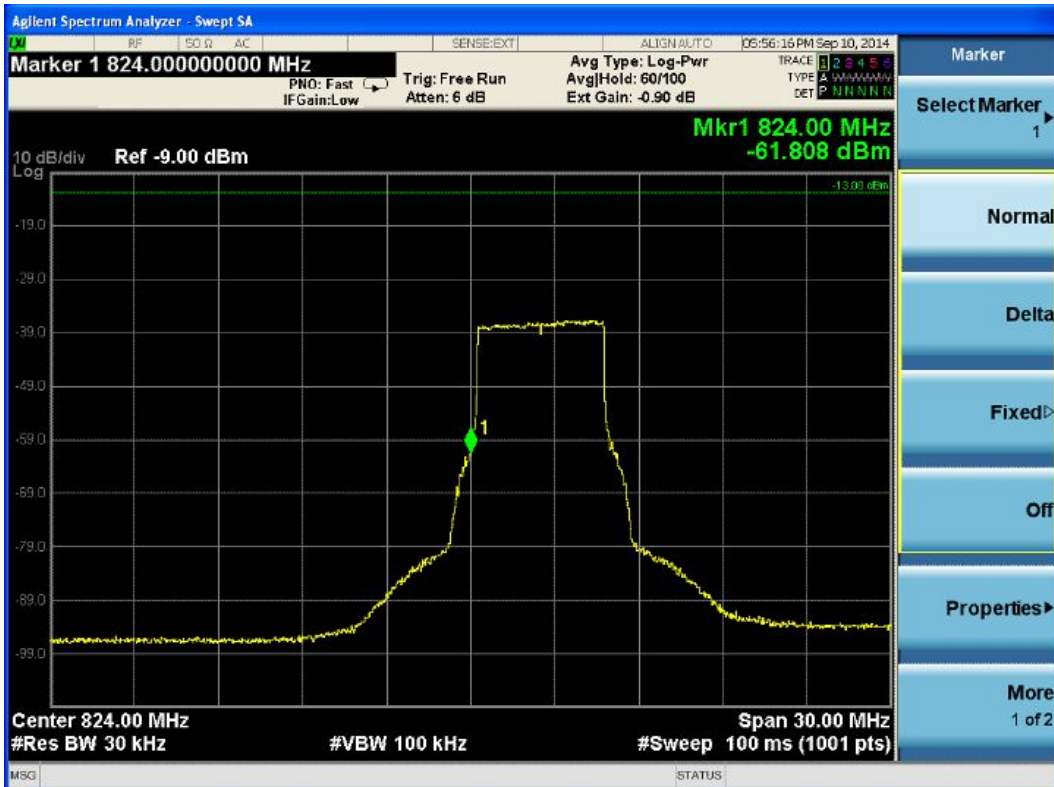

(1.3.2) Upper Edge

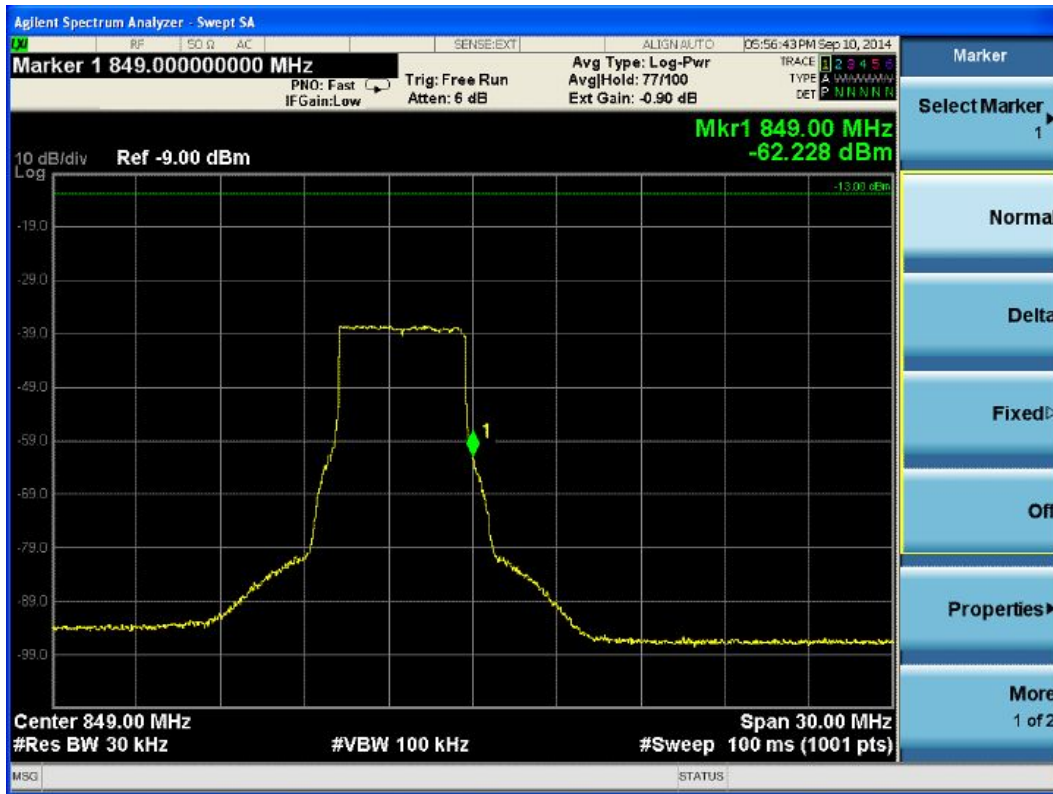

(1.4) Test for LTE 10MHz

(1.4.1) Lower Edge

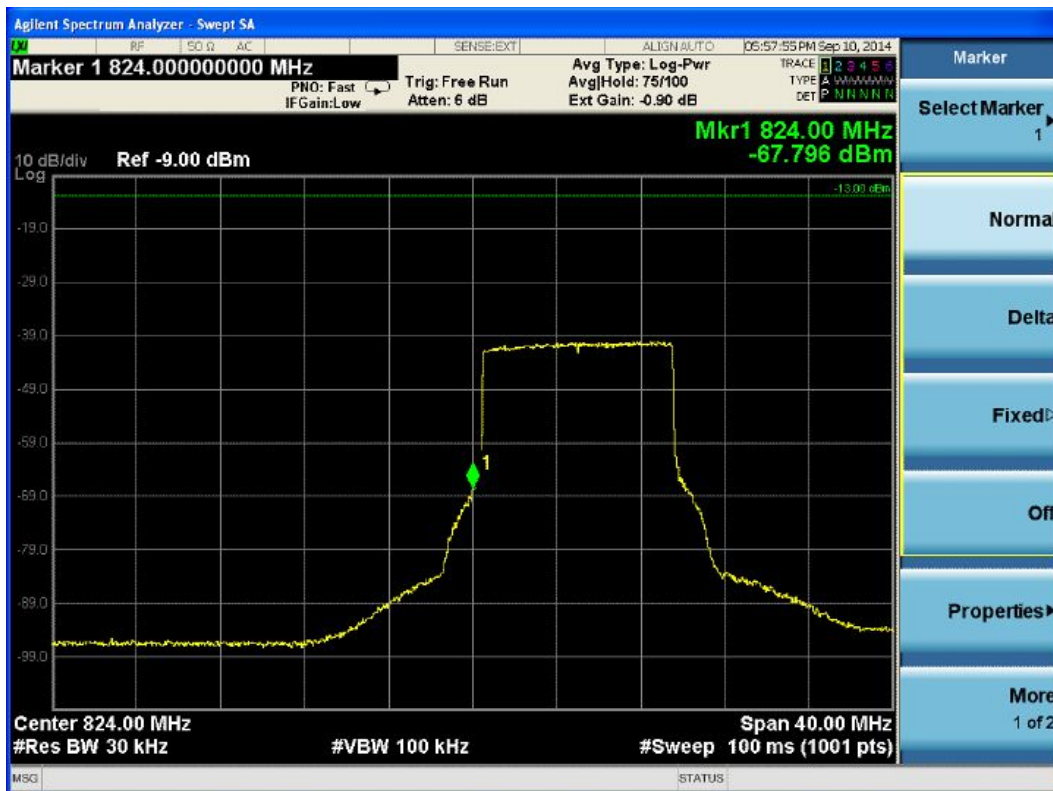

(1.4.2) Upper Edge

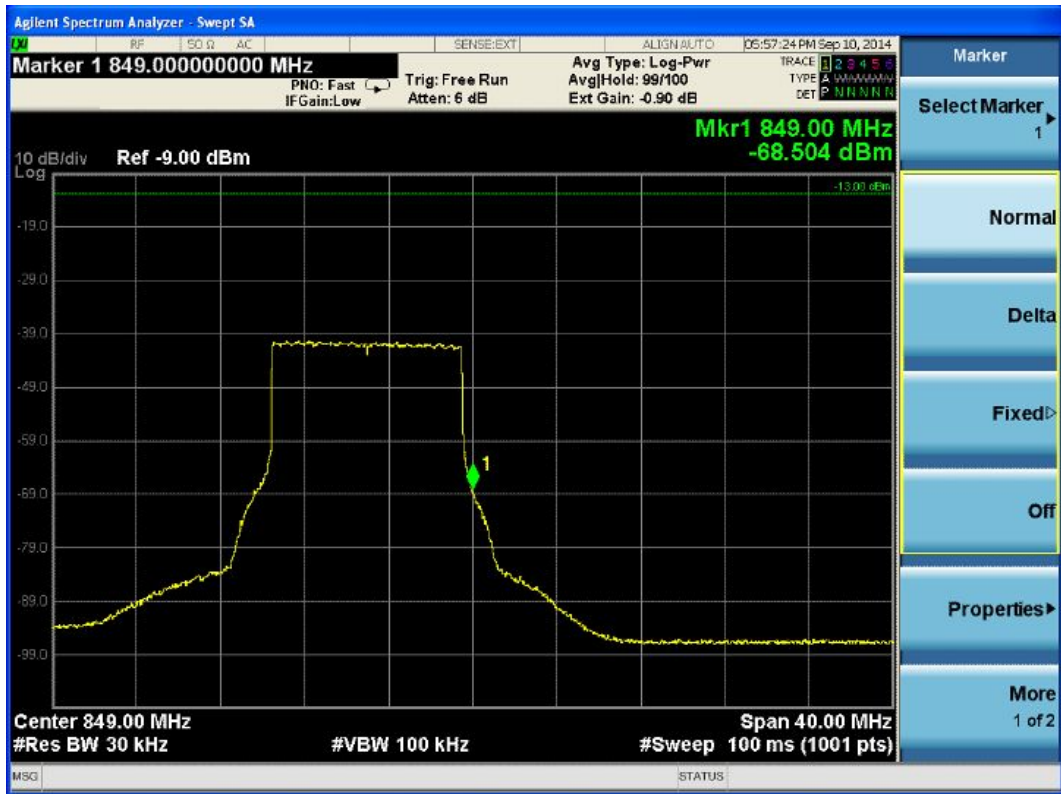

(1.5) Test for LTE 15MHz

(1.5.1) Lower Edge

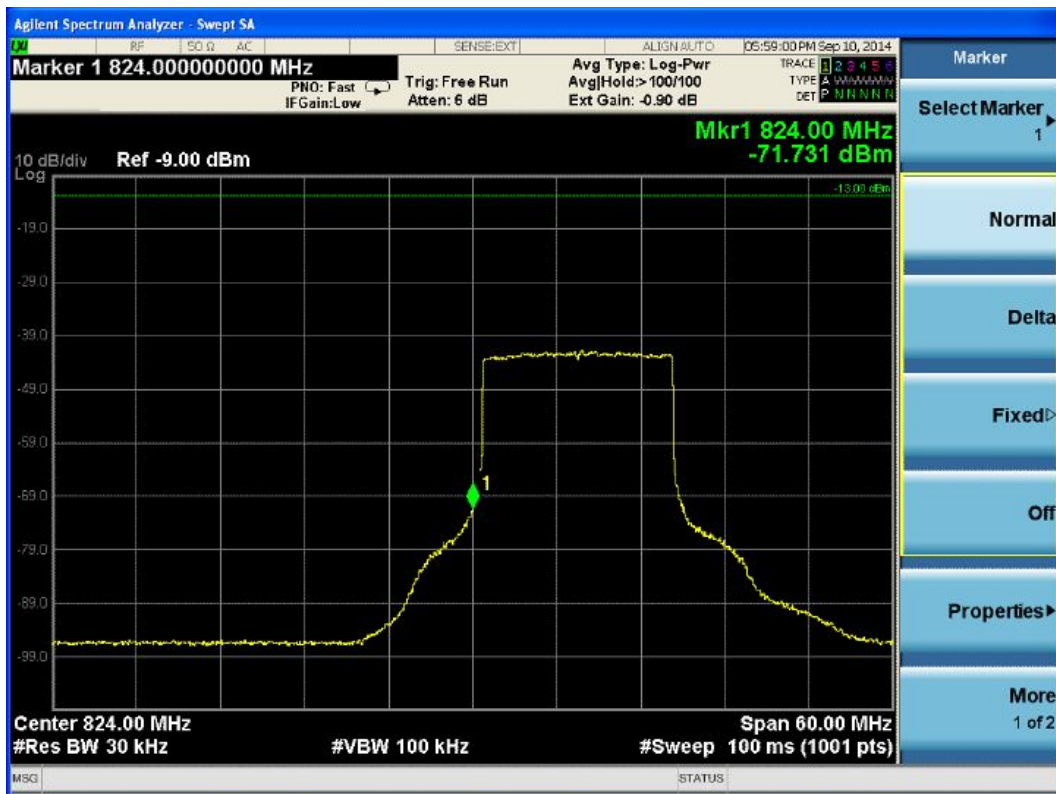

(1.5.2) Upper Edge

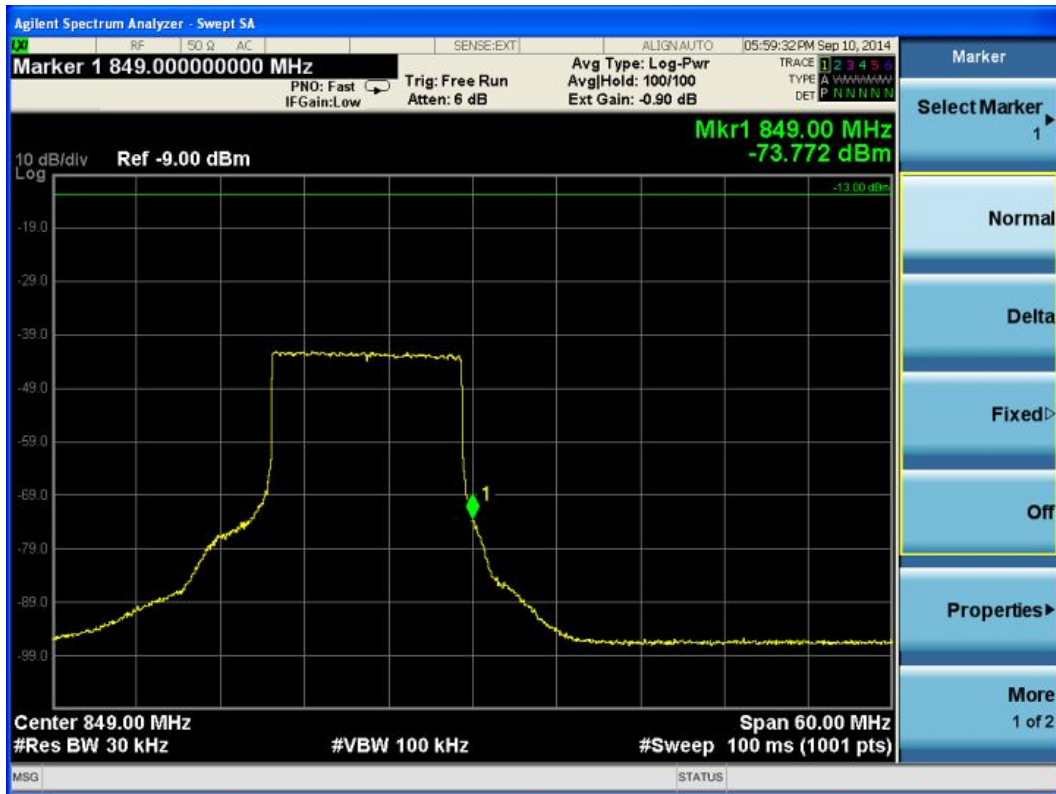

(1.6) Test for LTE 20MHz

(1.6.1) Lower Edge

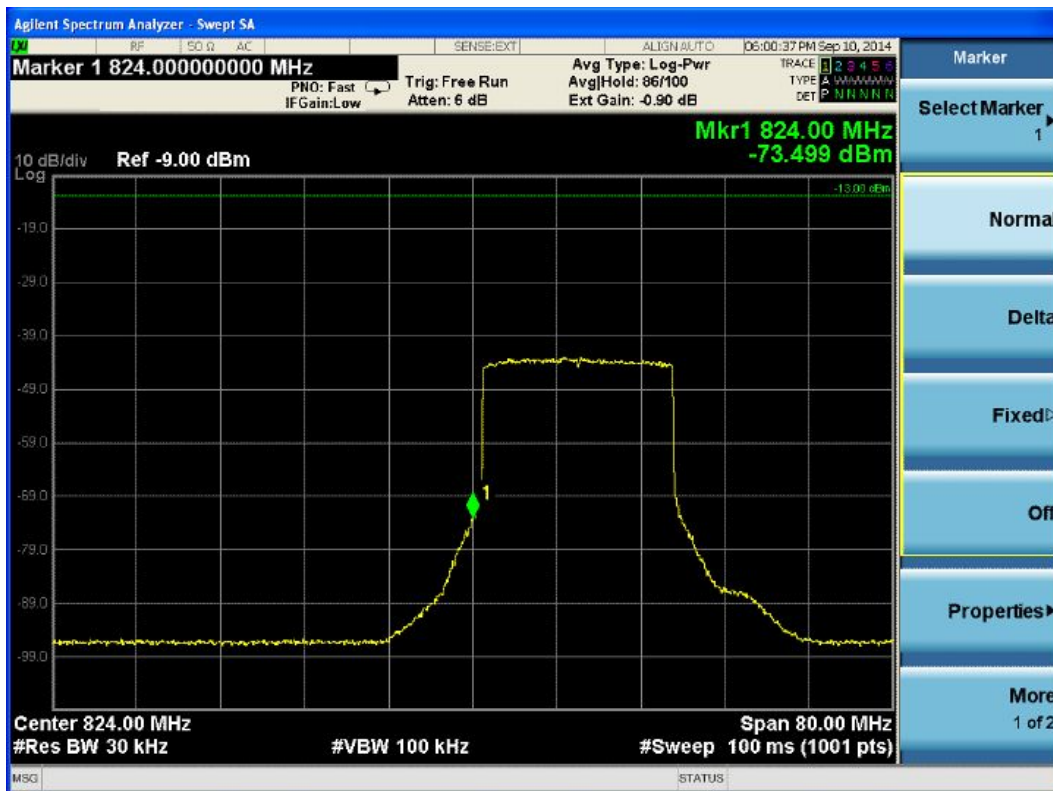

(1.6.2) Upper Edge

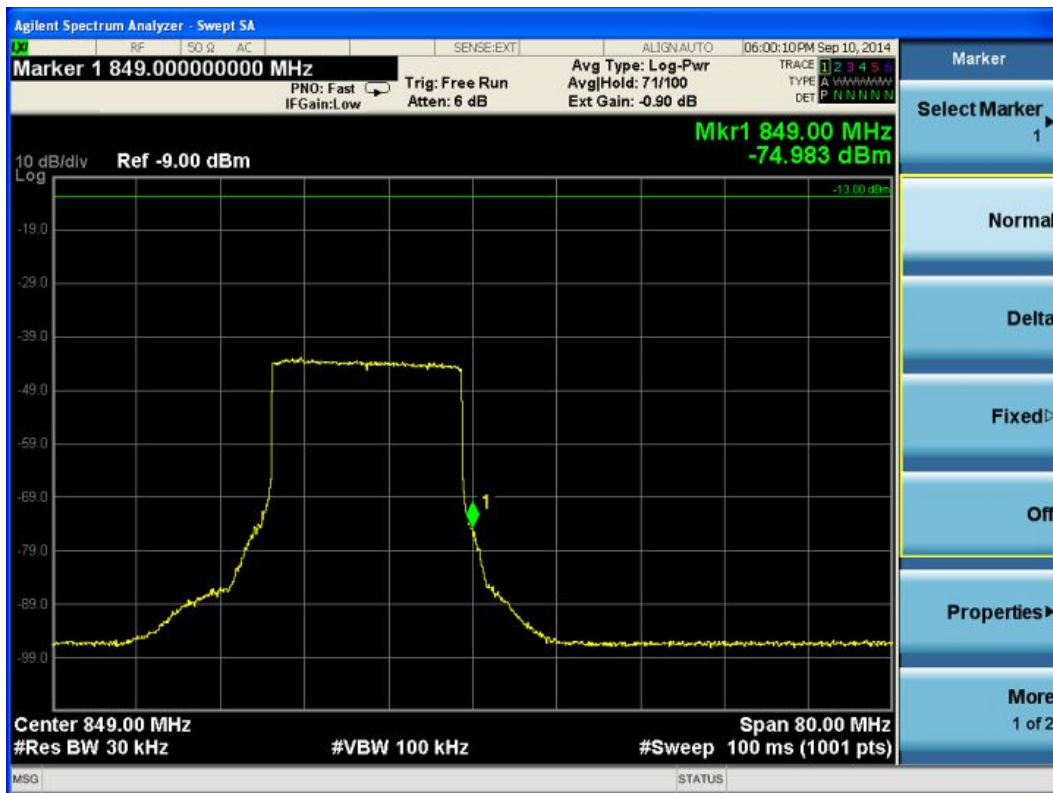

(2) GSM modulation

(2.1) Lower Edge

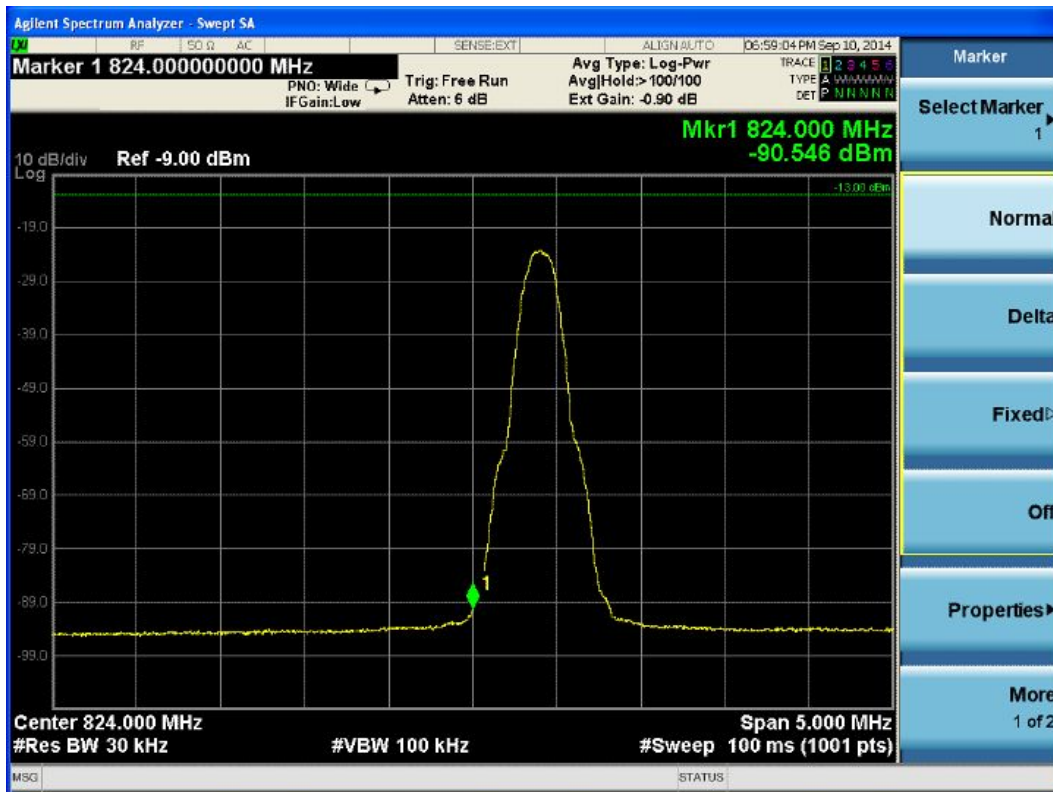

(2.2) Upper Edge

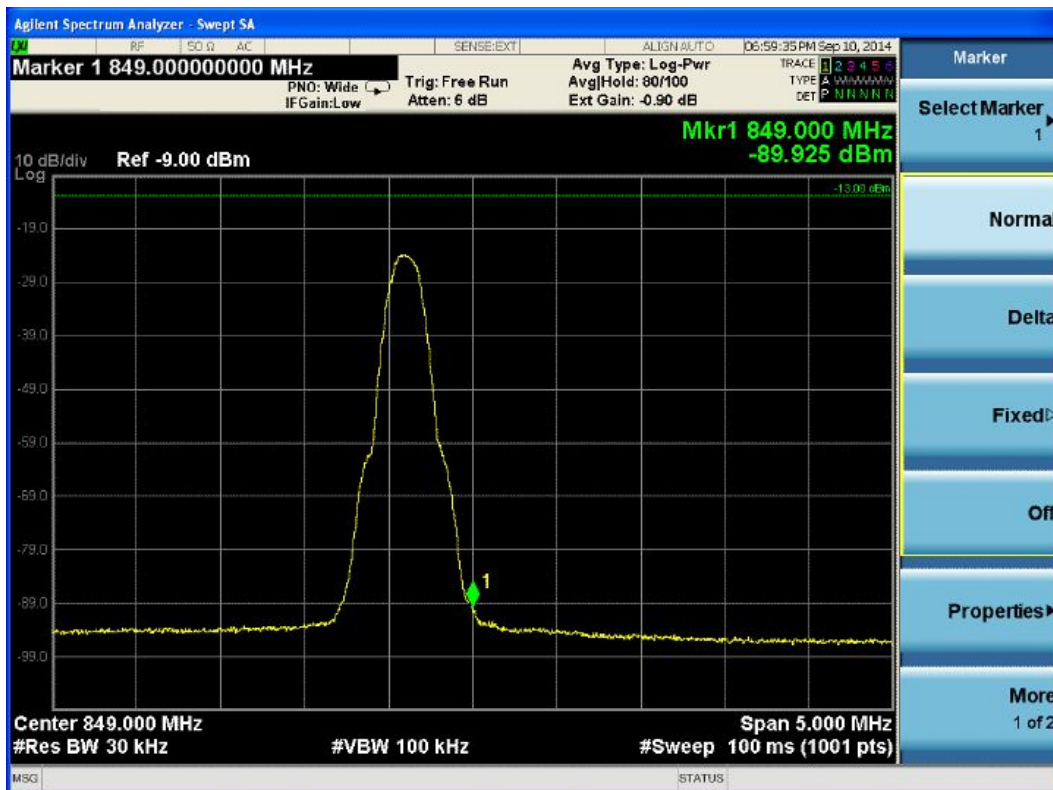

(3) CDMA modulation

(3.1) Lower Edge

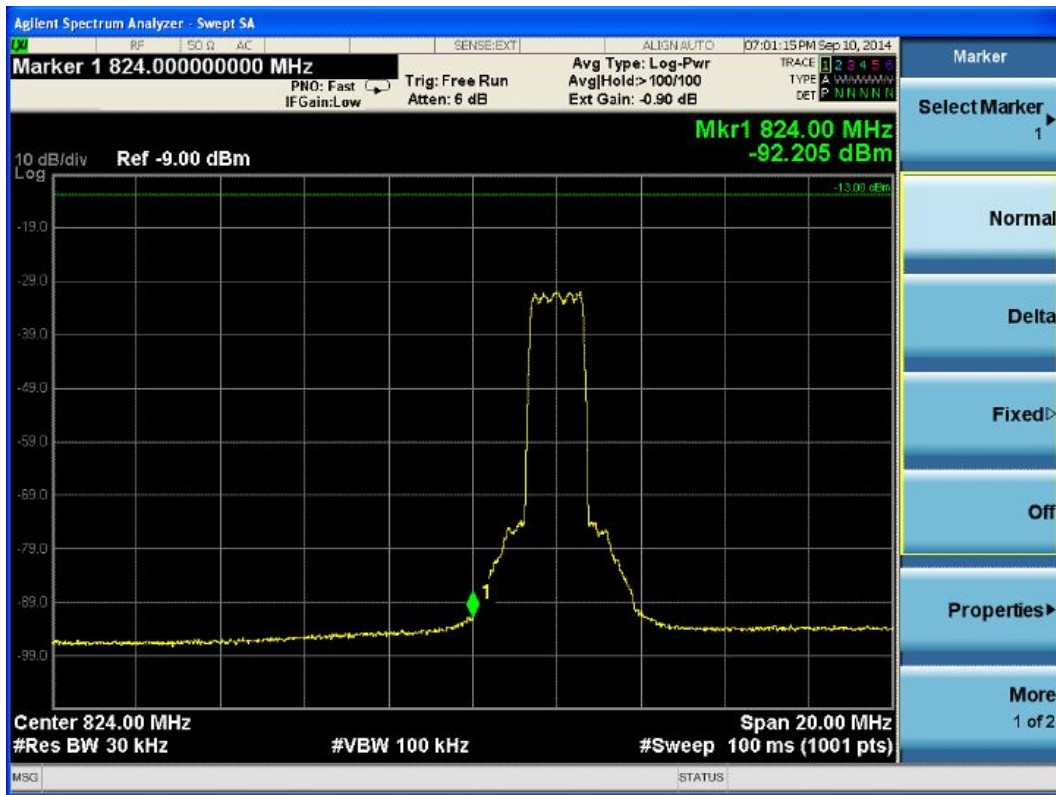

(3.2) Upper Edge

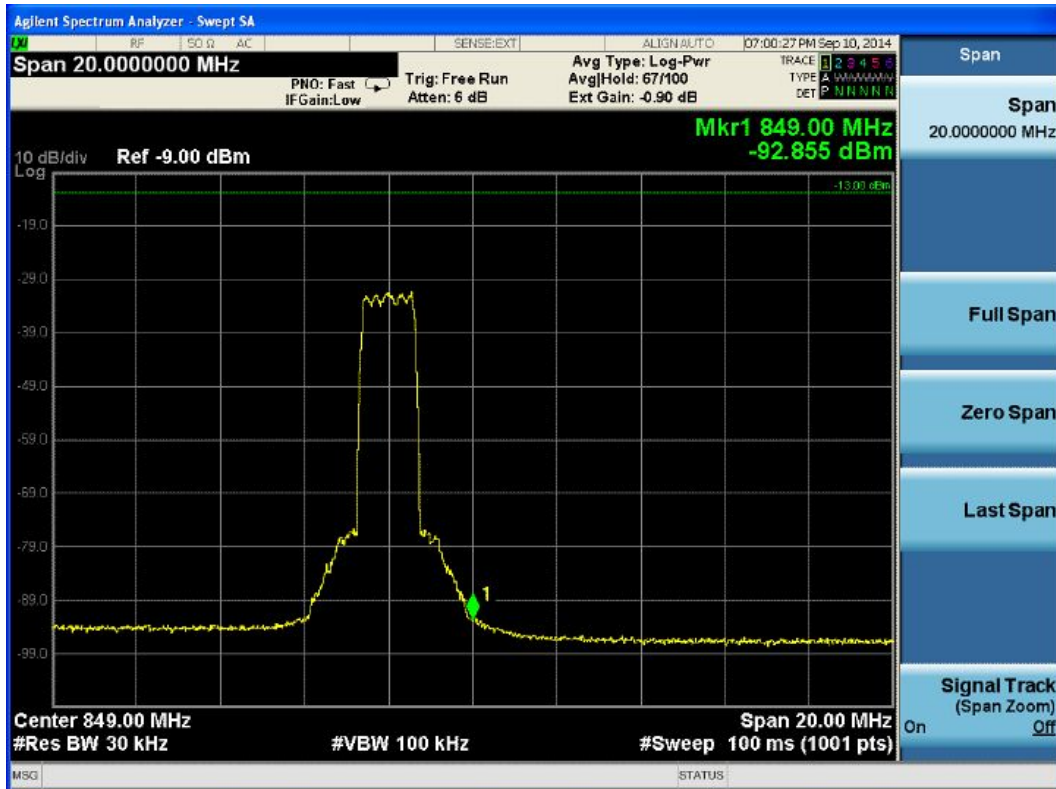

(4) WCDMA modulation

(4.1) Lower Edge

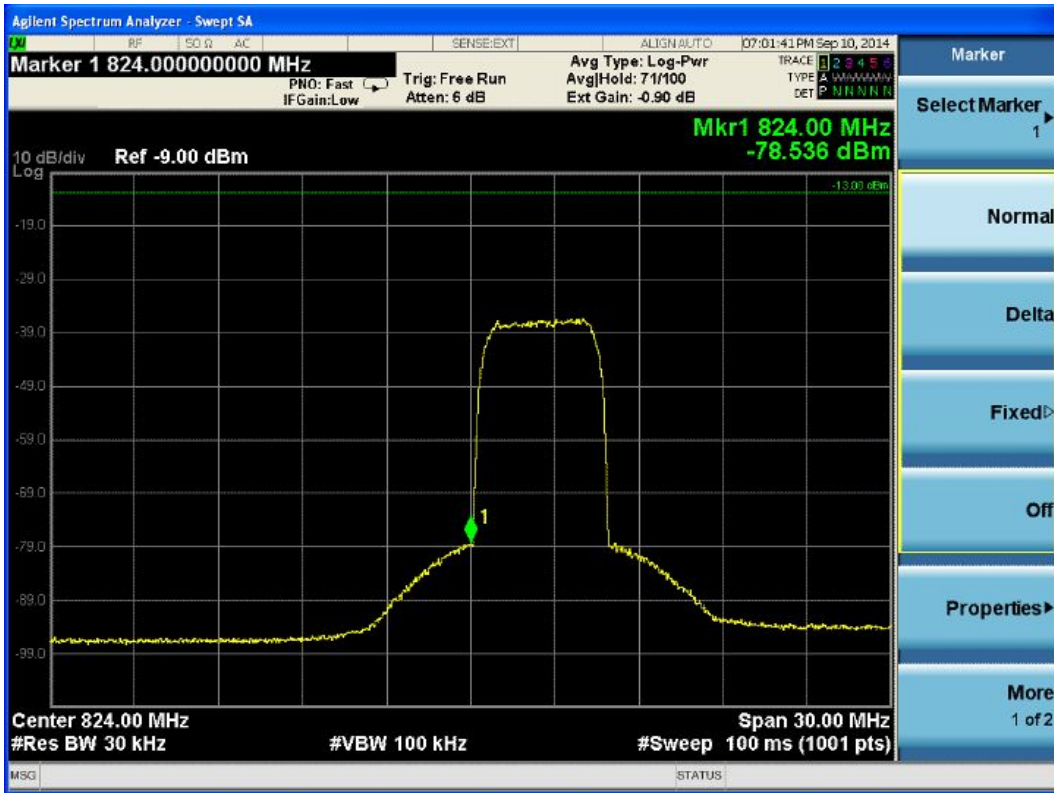

(4.2) Upper Edge

