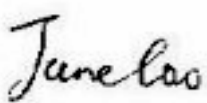
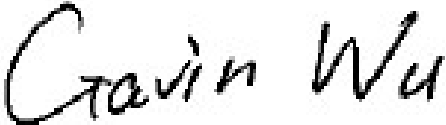

**GRGTEST****TEST REPORT**

<b>Report No.:</b>	<b>EM201300924</b>	<b>Application No.:</b>	<b>ZJ00035225</b>
<b>Client:</b>	Comba Telecom Ltd.		
<b>Address:</b>	611 East Wing, No. 8 Science Park West Avenue, Hong Kong Science Park Tai Po, Hong Kong		
<b>Sample Description:</b>	ComFlex 600 Series DAS		
<b>Model number:</b>	MU-6100		
<b>Test Location:</b>	EMC Laboratory of Guangzhou GRG Metrology and Test Co., Ltd.		
<b>Test Specification:</b>	FCC PART 27, FCC PART 22, FCC PART 24, FCC PART 2		
<b>Test Date:</b>	2013-10-15 to 2013-12-29		
<b>Issue Date:</b>	2013-12-29		
<b>Test Result:</b>	<i>Pass.</i>		
<b>Prepared By:</b>	<b>Reviewed By:</b>	<b>Approved By:</b>	
Jacky Zhang / Test Engineer	Jane Cao / Technical Support	Gavin Wu / Manager	
			
Date:2013-12-29	Date:2013-12-29	Date:2013-12-29	
<b>Other Aspects:</b>			
None			
<b>Abbreviations:</b> <i>ok / P = passed; fail / F = failed; n.a. / N = not applicable</i>			
<b>The test result in this test report refers exclusively to the presented test sample. This report shall not be reproduced except in full, without the written approval of GRGT.</b>			

### **DIRECTIONS OF TEST**

- 1. This station carries out test task according to the national regulation of verifications which can be traced to National Primary Standards and BIPM.**
  
- 2. The test report merely corresponds to the test sample. It is not permitted to copy extracts of these test result without the written permission of the test laboratory.**
  
- 3. If there is any objection concerning the test, the client should inform the laboratory within 15 days from the date of receiving the test report.**

## TABLE OF CONTENTS

<b>1. TEST SUMMARY .....</b>	<b>4</b>
<b>2. GENERAL INFORMATION .....</b>	<b>7</b>
<b>2.1 CLIENT INFORMATION .....</b>	<b>7</b>
<b>2.2 MANUFACTURER AND FACTORY .....</b>	<b>7</b>
<b>2.3 BASIC DESCRIPTION OF EUT .....</b>	<b>7</b>
<b>2.4 SIGNAL CONTROL PROCESS .....</b>	<b>8</b>
<b>2.5 STANDARDS APPLICABLE FOR TESTING .....</b>	<b>8</b>
<b>3. LABORATORY AND ACCREDITATIONS .....</b>	<b>9</b>
3.1 TEST LOCATION .....	9
3.2 ACCREDITATION .....	9
3.3 OTHER INFORMATION REQUESTED BY THE CUSTOMER .....	9
<b>4 EQUIPMENTS USED DURING TEST .....</b>	<b>10</b>
<b>5 TEST RESULTS .....</b>	<b>11</b>
<b>5.1 EUT OPERATION .....</b>	<b>11</b>
<b>5.2 TEST PROCEDURE &amp; MEASUREMENT DATA .....</b>	<b>14</b>
5.2.1 <i>RF Output Power</i> .....	14
5.3.2 <i>Conducted Spurious Emissions</i> .....	28
5.3.3 <i>Band Edge</i> .....	134
5.3.5 <i>Frequency Stability</i> .....	224
5.3.6 <i>Occupied Bandwidth</i> .....	232
5.3.7 <i>Out of Band Rejection</i> .....	340
5.3.8 <i>Radiated Spurious Emissions</i> .....	345

**1. Test summary**

Test Item	Frequency Band	Test Requirement	Test Method	Result
Output Power	700MHz Lower ABC Band	FCC part 27.50	FCC part 2. 1046& 935210 D02 Signal Boosters Certification v01r01	PASS
	700MHz Upper C Band	FCC part 27.50		PASS
	850MHz Band	FCC part 22.913		PASS
	1900MHz Broadband PCS	FCC part 24.232		PASS
	AWS-1 Band	FCC part 27.50		PASS
Conducted Spurious Emission	700MHz Lower ABC Band	FCC part 27.53	FCC part 2. 1051& 935210 D02 Signal Boosters Certification v01r01	PASS
	700MHz Upper C Band	FCC part 27.53		PASS
	850MHz Band	FCC part 22.917		PASS
	1900MHz Broadband PCS	FCC part 24.238		PASS
	AWS-1 Band	FCC part 27.53		PASS
Band Edge	700MHz Lower ABC Band	FCC part 27.53	FCC part 2. 1051& 935210 D02 Signal Boosters Certification v01r01	PASS
	700MHz Upper C Band	FCC part 27.53		PASS
	850MHz Band	FCC part 22.917		PASS
	1900MHz Broadband PCS	FCC part 24.238		PASS
	AWS-1 Band	FCC part 27.53		PASS
Radiated Spurious Emission	700MHz Lower ABC Band	FCC part 27.53	FCC part 2 1053& 935210 D02 Signal Boosters Certification v01r01	PASS
	700MHz Upper C Band	FCC part 27.53		PASS
	850MHz Band	FCC part 22.917		PASS

	1900MHz Broadband PCS	FCC part 24.238		PASS
	AWS-1 Band	FCC part 27.53		PASS
Occupied Bandwidth	700MHz Lower ABC Band	935210 D02 Signal Boosters Certification v01r01	FCC part 2.1049& 935210 D02 Signal Boosters Certification v01r01	PASS
	700MHz Upper C Band	935210 D02 Signal Boosters Certification v01r01		PASS
	850MHz Band	935210 D02 Signal Boosters Certification v01r01		PASS
	1900MHz Broadband PCS	935210 D02 Signal Boosters Certification v01r01		PASS
	AWS-1 Band	935210 D02 Signal Boosters Certification v01r01		PASS
Intermodulation	700MHz Lower ABC Band	FCC part 27.53	935210 D02 Signal Boosters Certification v01r01	PASS
	700MHz Upper C Band	FCC part 27.53		PASS
	850MHz Band	FCC part 22.917		PASS
	1900MHz Broadband PCS	FCC part 24.238		PASS
	AWS-1 Band	FCC part 27.53		PASS
Frequency Stability	700MHz Lower ABC Band	FCC part 27.54	FCC part 2.1055	PASS
	700MHz Upper C Band	FCC part 27.54		PASS
	850MHz Band	FCC part 22.355		PASS

	1900MHz Broadband PCS	FCC part 24.135		PASS
	AWS-1 Band	FCC part 27.54		PASS
Out of Band Rejection	700MHz Lower ABC Band	935210 D02 Signal Boosters Certification v01r01	935210 D02 Signal Boosters Certification v01r01	PASS
	700MHz Upper C Band	935210 D02 Signal Boosters Certification v01r01	935210 D02 Signal Boosters Certification v01r01	PASS
	850MHz Band	935210 D02 Signal Boosters Certification v01r01	935210 D02 Signal Boosters Certification v01r01	PASS
	1900MHz Broadband PCS	935210 D02 Signal Boosters Certification v01r01	935210 D02 Signal Boosters Certification v01r01	PASS
	AWS-1 Band	935210 D02 Signal Boosters Certification v01r01	935210 D02 Signal Boosters Certification v01r01	PASS

**Remark:**

Tx: In this whole report Tx (or tx) means Transmitter.

Rx: In this whole report Rx(or rx) means Receiver.

## 2. General information

### 2.1 Client information

Name: Comba Telecom Ltd  
Address: 611 East Wing, No. 8 Science Park West Avenue, Hong Kong Science Park  
Tai Po, Hong Kong

### 2.2 Manufacturer and Factory

Name: Comba Telecom Systems(China) Ltd.  
Address of Manufacture: No. 10 Shenzhou Road, Guangzhou Science City  
Factory: Comba Telecom Systems(China) Ltd.  
Address of Factory: No. 10 Shenzhou Road, Guangzhou Science City

### 2.3 Basic description of EUT

Product Name: ComFlex 600 Series DAS  
Model number.: MU-6100  
Power Supply: Master Unit: AC 100-240V, 50/60Hz  
Remote Unit: AC 100-240V, 50/60Hz  
Power Cord: AC power cord  
Type of Modulation: LTE&GSM&CDMA&WCDMA&1x EV-DO  
Frequency Band: (1) 700MHz Lower ABC Band:  
Downlink: 728MHz ~ 746MHz, Uplink: 698MHz ~ 716MHz.  
Type of Modulation: LTE  
(2) 700MHz Upper C Band:  
Downlink: 746MHz ~ 757MHz, Uplink: 776MHz ~ 787MHz.  
Type of Modulation: LTE  
(3) 850MHz Band:  
Downlink: 869MHz ~ 894MHz, Uplink: 824MHz ~ 849MHz.  
Type of Modulation: LTE&GSM&CDMA&WCDMA&1x EV-DO  
(4) 1900MHz Broadband PCS:  
Downlink: 1930MHz ~ 1995MHz, Uplink: 1850MHz ~ 1915MHz.  
Type of Modulation: LTE&GSM&CDMA&WCDMA&1x EV-DO

(6) AWS-1 Band:

Downlink: 2110MHz ~ 2155MHz, Uplink:1710MHz ~ 1755MHz.

Type of Modulation: LTE&CDMA&WCDMA&1x EV-DO

Normal Power 30dBm for the center frequency of Downlink

Output -25dBm for the center frequency of Uplink

Normal System 20dB for Downlink

Gain 20dB for Uplink

Antenna Type: N/A

## 2.4 Signal control process

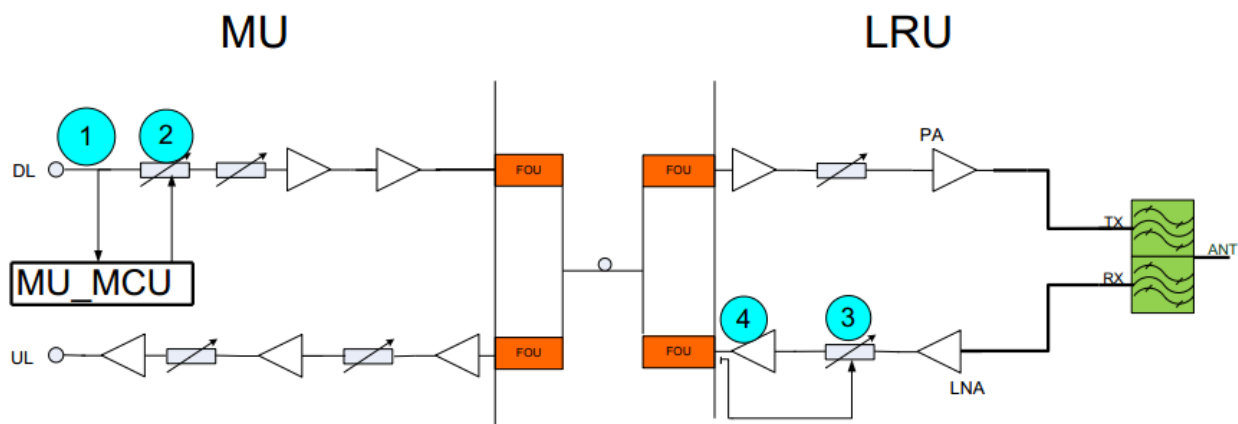

### Downlink:

MU will test the input level at location mark 1 and send the value to MCU, software will compare the value with the standard value (10dBm), if the received value is higher than standard value, MCU will set ATT at location 2. (ATT=input power value-standard value)

### Uplink:

Mark 3 and Mark 4 in LRU are the ALC(auto level control) circuit. Detection circuit detect the RU uplink output power at location mark4 and send to differential comparator to compare with the standard RU uplink output power(+1dBm), and the output of differential comparator will send control level to attenuator at location mark 3 to make sure the RU uplink output power is not higher than +1 dBm, so that MU uplink output power is not higher than -25dBm.

## 2.5 Standards applicable for testing

The standard used FCC part 27, part 22, part 24, part 2;



### 3. Laboratory and accreditations

#### 3.1 Test location

The tests and measurements refer to this report were performed by Guangzhou GRG Metrology and Test Co., Ltd.

Add.: 163 Pingyun Rd, West of Huangpu Ave, Guangzhou, 510656, P. R. China

Telephone: +86-20-38699959, 38699960, 38699961

Fax : +86-20-38695185

#### 3.2 Accreditation

Our laboratories are accredited and approved by the following approval agencies according to ISO/IEC 17025.

<b>USA</b>	FCC Listed Lab No. 688188
<b>China</b>	CNAS NO.L0446
<b>China</b>	DILAC No.DL175
<b>Canada</b>	Registration No.:8355A-1

#### 3.3 Other information requested by the customer

N/A

**4 Equipments used during test**

Name of Equipment	Manufacturer	Model	Serial Number	Calibration Due(yy-mm-dd)	Calibration Interval
Signal Generator	R&S	SMBV100A	256543	2013-02-17	2014-02-17
Signal Generator	R&S	SMJ100A	101700	2013-09-18	2014-09-18
Spectrum analyzer	Agilent	N9030A	MY50141151	2013-10-09	2014-10-09
Frequency meter	FLUKE	PM6685R	826664	2013-05-08	2014-05-08
Voltage parameters tester	China weibo	PF1211	192427	2013-04-05	2014-04-04
Power splitter	Comba	RD-52N/NP-B0	0503040152	----	----
Voltage regulator	China tianzheng	TDGC2J-5	0754	2013-09-30	2014-09-29
High low temperature test box	China baoyuan	BYG-1000R2	112106	2013-09-26	2014-09-25
<b>Radiated Spurious Emission</b>					
Spectrum Analyzey	R&S	ESU40	100106	2013-07-26	2014-07-25
Biconical antenna	ELECTRO-METRICS	BIA-30S	166	2013-08-13	2013-08-12
Log-periodical antenna	ELECTRO-METRICS	LPA-30	383	2013-07-30	2014-07-29
Horn antenna	ETS.LINDGR EN	3117	00075824	2013-08-20	2014-08-19
Biconical Log-periodic antenna	ETS.LINDGR EN	3142C	00075971	2013-07-29	2014-07-28
Horn antenna	SCHWARZBECK	BBHA9120D	D752	2013-09-09	2014-09-08
Signal Generator	R&S	SML03	103002	2013-09-02	2014-09-01
Filter	TELONIC	TTR95-3EE	50076	2013-09-06	2014-09-05

## 5 Test results

### 5.1 EUT operation

Test Date (yy-mm-dd):	26 Dec, 2013 to 29 Dec, 2013
Test Method:	FCC part 2
Test Requirement:	FCC part 27, part 24, part 22
Ambient Temp:	20.0°C
Humid :	67%
Atmospheric Pressure:	1005mbar
Power supply:	AC 120V 60Hz

Test Requirement:

Fiber-optic distribution systems are a type of in-building radiation system that receives RF signals from an antenna, distributes the signal over fiber-optic cable, and then retransmits at another location for example within a building or tunnel. Most fiber-optic systems are signal booster; however, some may be repeaters. These systems generally have two enclosures typically called host(or local or donor unit) and remote. Some systems may also have an optional expander box for fan-out to multiple remotes. The system transmits downlink signals from the remote unit to handsets, portables, or clients, and transmits uplink signals via from the host unit. Usually but not always the uplink goes through an intermediate amplifier to a “donor” antenna. Therefore both uplink and downlink must be tested, unless filing effectively documents how connection of uplink to donor antenna with or without an intermediate amplifier will be prevented, such as for always only a cabled connection to a base station. Fiber-optic systems are not amplifiers (AMP equipment class) – they are equipment class TNB or PCB. The same approval procedures also apply for multiple-enclosure systems connected by coax cable.

#### 1) *host unit*

- a) transmits uplink to base station via antenna thru coax, *passive interface unit*, or *active interface unit*(amplifier).
- b) sends base-station downlink via fiber-optic or coax to *remote*.
- c) receives handset uplink via fiber-optic or coax from *remote*.
- d) separate FCC ID from *remote*, unless electrically identical.
- e) *non-transmitting host unit*
  - i) connects directly to a base station via coax cable but does not connect to antenna or amplifier.

- ii) Part 15 digital device subject to Verification, no FCC ID.
- 2) **remote unit**
    - a) receives base-station downlink via fiber-optic or coax from **host**, transmits via antenna to handsets.
    - b) Returns handset uplink via fiber-optic or coax to **host**.
    - c) Separate FCC ID from **remote**, unless electrically identical.
  - 3) **passive interface unit**
    - a) contains attenuators, splitters,combiners.
    - b) coax cable connection between **host** and base-station.
    - c) Pass device, no FCC ID.
  - 4) **active interface unit**
    - a) amplifies uplink signal from host unit for transmit by donor antenna.
    - b) attenuates downlink from donor antenna.
    - c) coax cable connection between **host** and **active interface unit**.
    - d) Usually has separate FCC ID; in some cases could be combined/included with **host** as one enclosure.

## Remark:

### GENERAL DEFINITIONS FOR CERTIFICATION PURPOSES:

The following three general definitions are applicable in this annex for equipment authorization purpose. The general term “extender” is the same as booster, but booster should be used rather than extender. The general term “translator” is the same as repeater, but repeater should be used rather than translator.

**External radio frequency power amplifier(ERFPA)** –any device which, (1) when used in conjunction with a radio transmitter signal source, is capable of amplification of that signal, and (2) is not an integral part of a radio transmitter as manufactured. The EAS equipment class AMP is used only for an ERFPA device inserted between a transmitter (TNB/PCB) and an antenna (has only one antenna port).

**Booster** is a device that automatically reradiates signals from base transmitters without channel translation, for the purpose of improving the reliability of existing service by increasing the signal strength in dead spots. An “in-buliding radiation system” is a signal booster. These devices are not intended to extend the size of coverage from the originating

base station. A booster can be either single or multiple channels.

**Repeater** is a device that retransmits the signals of other stations. Repeaters are different from boosters in that they can include frequency translation and can extend coverage beyond the design of the original base station. A repeater is typically single channel but can also be multiple channels.

For Consumer Signal Boosters, uniform test procedures consistent with the new requirements in the Order are presently under development, and as soon as available will be released as a separate attachment under this KDB 935210 publication number. In addition, per the Order for §§90.219 (d) and 90.219 (e) contain specific provisions for which information and test data must be included in application;<sup>2</sup> uniform test procedures for the §90.219 requirements will be amended to KDB 935210 as soon available.

For devices other than consumersignal boosters, tests should be done with each typical signal. e.g., for F3E emissions use 2500 Hz with 2.5kHz or 5 kHz deviation. Use of CW signal for some tests is acceptable in lieu of actual emission, in some cases when CW signal gives worst case.

The EUT include host unit and remote unit.

**Host** separates FCC ID from **remote**.

## 5.2 Test procedure & Measurement Data

### 5.2.1 RF Output Power

Test Date: 26 Dec, 2013 to 26 Dec, 2013  
Ambient Temp: 20.0°C  
Humid : 67%  
Atmospheric Pressure: 1005mbar  
Power supply: AC 120V 60Hz  
Test Method: FCC part 2. 1046& 935210 D02 Signal Boosters Certification v01r01

Test Requirement:

700MHz Lower ABC Band FCC part 27. 50  
The effective radiated power (ERP) of base transmitters and cellular repeaters must not exceed 1000 Watts/MHz.

700MHz Upper C Band FCC part 27. 50  
The effective radiated power (ERP) of base transmitters and cellular repeaters must not exceed 1000 Watts/MHz.

850MHz Band FCC part 22. 913  
The effective radiated power (ERP) of base transmitters and cellular repeaters must not exceed 500 Watts/MHz.

1900MHz Broadband PCS FCC part 24. 232  
The effective radiated power (ERP) of base transmitters and cellular repeaters must not exceed 500 Watts/MHz.

AWS-1 Band FCC part 27. 50  
The effective radiated power (ERP) of base transmitters and cellular repeaters must not exceed 1 Watts/MHz.

Test conditions: Normal conditions

Test configuration:

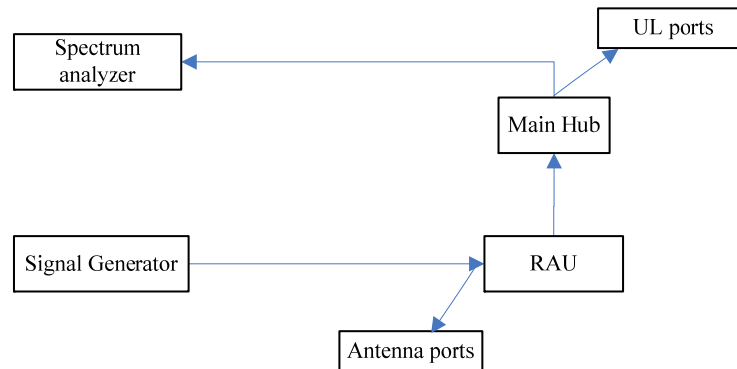

Figure 1: Uplink RF Output Power Configuration

Test Procedure:

RF output power test procedure:

- a) Connect the equipment as illustrated, when the output power is over the maximum value of the Spectrum Analyzer, add the attenuator to avoid destroying the facility.
- b) Set the center frequency of the Spectrum Analyzer to assigned transmitter frequency, key the transmitter, and set the level of the carrier to the full scale reference line.
- c) Do not apply any tone to modulate the EUT
- d) Adjust the Spectrum Analyzer for the following setting:
  - 1) Resolution Bandwidth  $\gg$  the carrier bandwidth
  - 2) Video Bandwidth refer to standard requirement
- e) Use Spectrum Analyzer channel power measurement
- f) Record the frequencies and levels of carrier power
- g) Calculate the signal link way loss and final power value

**Remark:**

Output power:

Power on Form 731 should be clearly understood as either composite of multi-channels or per carrier, If power is composite include in comments field: "Power output listed is composite for multi-channel operation."

Check that the input drive level is at the maximum input rating and maximum gain setting for all tests. Check both uplink and downlink input level. See manual or brochures/technical description for maximum rating. May need to check FCC identifier of transmitter used for tests.

Confirm device cannot operate in saturation. Are there means to control maximum power and to assure linear operation (use

in system configuration may be necessary)? How is saturation or over-modulation prevented for pulsed signal inputs?



### 5.3.1.1 Measurement Record

#### 1) 700MHz Lower ABC Band

Frequency Band	Modulation	Frequency	Max. Output power(dBm)	Max. value in W
Uplink: Working Band (Lower A: 698MHz~704MHz; Lower B: 704MHz~710MHz; Lower C: 710MHz~716MHz) Measure Max. Output power				
Lower A	LTE(1.4MHz)	Lowest Frequency 698.7 MHz	-23.15	0.0048W
		Middle frequency 701 MHz	-23.45	
		Highest frequency 703.3 MHz	-24.37	
	LTE(5 MHz)	Lowest Frequency 700.5 MHz	-23.72	0.0042W
		Middle frequency 701 MHz	-23.89	
		Highest frequency 701.5 MHz	-24.08	
Lower B	LTE(1.4MHz)	Lowest Frequency 704.7 MHz	-24.67	0.0034W
		Middle frequency 707 MHz	-25.08	
		Highest frequency 709.3 MHz	-24.99	
	LTE(5 MHz)	Lowest Frequency 706.5 MHz	-25.23	0.0030W
		Middle frequency 707 MHz	-25.34	
		Highest frequency 707.5 MHz	-25.34	
Lower C	LTE(1.4MHz)	Lowest Frequency 710.7 MHz	-24.73	0.0047W
		Middle frequency 713 MHz	-23.31	
		Highest frequency 715.3 MHz	-23.26	
	LTE(5 MHz)	Lowest Frequency 712.5 MHz	-24.07	0.0043W
		Middle frequency 713 MHz	-23.74	

		Highest frequency 713.5 MHz	-23.64	
Lower ABC Full Band	LTE(10 MHz)	Lowest Frequency 703 MHz	-24.85	0.0033W
		Middle frequency 707 MHz	-25.45	
		Highest frequency 711 MHz	-24.98	

Remark: test in single channel status, output power is tested in full amplifying status.

Kept the EUT working in maximum gain, adjusted the input power until to get the EUT to maximum output power.

**2) 700MHz Upper C Band**

Modulation	Frequency	Max. Output power(dBm)	Max. value in W
Uplink: Working Band (776MHz~787MHz) Measure Max. Output power			
LTE(1.4MHz)	Lowest Frequency 776.7 MHz	-26.74	0.0045W
	Middle frequency 781.5 MHz	-23.49	
	Highest frequency 786.3 MHz	-25.98	
LTE(5 MHz)	Lowest Frequency 778.5 MHz	-25.53	0.0041W
	Middle frequency 781.5 MHz	-23.91	
	Highest frequency 784.5 MHz	-24.82	
LTE(10 MHz)	Lowest Frequency 781 MHz	-24.90	0.0033W
	Middle frequency 781.5 MHz	-24.86	
	Highest frequency 782 MHz	-24.81	

Remark: test in single channel status, output power is tested in full amplifying status.

Kept the EUT working in maximum gain, adjusted the input power until to get the EUT to maximum output power.

### 3) 850MHz Band

#### 3.1) LTE modulation

Modulation	Frequency	Max. Output power(dBm)	Max. value in W
Uplink: Working Band (824MHz~849MHz) Measure Max. Output power			
LTE(1.4MHz)	Lowest Frequency 824.7 MHz	-25.54	0.0033W
	Middle frequency 836.5 MHz	-24.78	
	Highest frequency 848.3 MHz	-25.82	
LTE(5 MHz)	Lowest Frequency 826.5 MHz	-25.73	0.0031W
	Middle frequency 836.5 MHz	-25.11	
	Highest frequency 846.5 MHz	-25.90	
LTE(10 MHz)	Lowest Frequency 829 MHz	-25.81	0.0029W
	Middle frequency 836.5 MHz	-25.40	
	Highest frequency 844 MHz	-25.93	
LTE(20 MHz)	Lowest Frequency 834 MHz	-25.78	0.0026W
	Middle frequency 836.5 MHz	-25.78	
	Highest frequency 839 MHz	-25.86	

Remark: test in single channel status, output power is tested in full amplifying status.

Kept the EUT working in maximum gain, adjusted the input power until to get the EUT to maximum output power.

**3.2) GSM modulation**

Modulation	Frequency	Max. Output power(dBm)	Max. value in W
Uplink: Working Band (824MHz~849MHz) Measure Max. Output power			
GSM(300kHz)	Lowest Frequency 824.4 MHz	-25.83	0.0032W
	Middle frequency 836.5 MHz	-24.99	
	Highest frequency 848.6 MHz	-26.04	

**3.3) CDMA modulation**

Modulation	Frequency	Max. Output power(dBm)	Max. value in W
Uplink: Working Band (824MHz~849MHz) Measure Max. Output power			
CDMA2000 (1.25MHz)	Lowest Frequency 826 MHz	-25.15	0.0035W
	Middle frequency 836.5 MHz	-24.57	
	Highest frequency 847 MHz	-25.47	

**3.4) WCDMA modulation**

Modulation	Frequency	Max. Output power(dBm)	Max. value in W
Uplink: Working Band (824MHz~849MHz) Measure Max. Output power			
WCDMA(5MHz)	Lowest Frequency 826.5 MHz	-25.49	0.0032W
	Middle frequency 836.5 MHz	-24.91	
	Highest frequency 846.5 MHz	-25.74	

**3.5) 1x EV-DO modulation**

Modulation	Frequency	Max. Output power(dBm)	Max. value in W
------------	-----------	------------------------	-----------------

Uplink: Working Band (824MHz~849MHz) Measure Max. Output power			
1x EV-DO (1.25MHz)	Lowest Frequency 826 MHz	-23.91	0.0047W
	Middle frequency 836.5 MHz	-23.31	
	Highest frequency 847 MHz	-24.14	

#### 4) 1900MHz Broadband PCS

##### 4.1) LTE modulation

Modulation	Frequency	Max. Output power(dBm)	Max. value in W
Uplink: Working Band (1850MHz~1915MHz) Measure Max. Output power			
LTE(1.4MHz)	Lowest Frequency 1850.7 MHz	-23.66	0.0043W
	Middle frequency 1882.5 MHz	-24.49	
	Highest frequency 1914.3 MHz	-25.16	
LTE(5 MHz)	Lowest Frequency 1852.5 MHz	-23.11	0.0048W
	Middle frequency 1882.5 MHz	-24.56	
	Highest frequency 1912.5 MHz	-24.16	
LTE(10 MHz)	Lowest Frequency 1855 MHz	-23.72	0.0042W
	Middle frequency 1882.5 MHz	-24.50	
	Highest frequency 1910 MHz	-22.90	
LTE(20 MHz)	Lowest Frequency 1860 MHz	-23.12	0.0048W
	Middle frequency 1882.5 MHz	-24.30	
	Highest frequency 1905 MHz	-22.95	

Remark: test in single channel status, output power is tested in full amplifying status.

Kept the EUT working in maximum gain, adjusted the input power until to get the EUT to maximum output power.

**4.2) GSM modulation**

Modulation	Frequency	Max. Output power(dBm)	Max. value in W
Uplink: Working Band (1850MHz~1915MHz) Measure Max. Output power			
GSM(300kHz)	Lowest Frequency 1850.4 MHz	-22.95	0.0051W
	Middle frequency 1882.5 MHz	-24.62	
	Highest frequency 1914.6 MHz	-25.55	

**4.3) CDMA modulation**

Modulation	Frequency	Max. Output power(dBm)	Max. value in W
Uplink: Working Band (1850MHz~1915MHz) Measure Max. Output power			
CDMA2000 (1.25MHz)	Lowest Frequency 1852 MHz	-22.89	0.0051W
	Middle frequency 1882.5 MHz	-24.38	
	Highest frequency 1913 MHz	-24.34	

**4.4) WCDMA modulation**

Modulation	Frequency	Max. Output power(dBm)	Max. value in W
Uplink: Working Band (1850MHz~1915MHz) Measure Max. Output power			
WCDMA(5MHz)	Lowest Frequency 1852.5 MHz	-23.16	0.0049W
	Middle frequency 1882.5 MHz	-24.49	
	Highest frequency 1912.5 MHz	-24.14	

**4.5) 1x EV-DO modulation**

Modulation	Frequency	Max. Output power(dBm)	Max. value in W
------------	-----------	------------------------	-----------------



Uplink: Working Band (1850MHz~1915MHz) Measure Max. Output power			
1x EV-DO (1.25MHz)	Lowest Frequency 1852 MHz	-22.82	0.0052W
	Middle frequency 1882.5 MHz	-24.22	
	Highest frequency 1913 MHz	-24.86	

## 5) AWS-1 Band

### 5.1) LTE modulation

Modulation	Frequency	Max. Output power(dBm)	Max. value in W
Uplink: Working Band (1710MHz~1755MHz) Measure Max. Output power			
LTE(1.4MHz)	Lowest Frequency 1710.7 MHz	-29.65	0.0030W
	Middle frequency 1732.5 MHz	-25.16	
	Highest frequency 1754.3 MHz	-27.47	
LTE(5 MHz)	Lowest Frequency 1712.5 MHz	-28.05	0.0033W
	Middle frequency 1732.5 MHz	-24.78	
	Highest frequency 1752.5 MHz	-27.31	
LTE(10 MHz)	Lowest Frequency 1715 MHz	-27.56/	0.0033W
	Middle frequency 1732.5 MHz	-24.81	
	Highest frequency 1750 MHz	-27.03	
LTE(20 MHz)	Lowest Frequency 1720 MHz	-26.20	0.0033W
	Middle frequency 1732.5 MHz	-24.87	
	Highest frequency 1745 MHz	-25.96	

Remark: test in single channel status, output power is tested in full amplifying status.

Kept the EUT working in maximum gain, adjusted the input power until to get the EUT to maximum output power.

**5.2) CDMA modulation**

Modulation	Frequency	Max. Output power(dBm)	Max. value in W
Uplink: Working Band (1710MHz~1755MHz) Measure Max. Output power			
CDMA2000 (1.25MHz)	Lowest Frequency 1712 MHz	-28.40	0.0033W
	Middle frequency 1732.5 MHz	-24.88	
	Highest frequency 1753 MHz	-27.63	

**5.3) WCDMA modulation**

Modulation	Frequency	Max. Output power(dBm)	Max. value in W
Uplink: Working Band (1710MHz~1755MHz) Measure Max. Output power			
WCDMA(5MHz)	Lowest Frequency 1712.5 MHz	-28.17	0.0033W
	Middle frequency 1732.5 MHz	-24.89	
	Highest frequency 1752.5 MHz	-27.49	

**5.4) 1x EV-DO modulation**

Modulation	Frequency	Max. Output power(dBm)	Max. value in W
Uplink: Working Band (1710MHz~1755MHz) Measure Max. Output power			
1x EV-DO (1.25MHz)	Lowest Frequency 1712 MHz	-27.54	0.0044W
	Middle frequency 1732.5 MHz	-23.58	
	Highest frequency 1753 MHz	-26.55	

### 5.3.2 Conducted Spurious Emissions

Test Date:	26 Dec, 2013 to 26 Dec, 2013
Ambient Temp:	20.0°C
Humid :	67%
Atmospheric Pressure:	1005mbar
Power supply:	AC 120V 60Hz
Test Method:	FCC part 2. 1051& 935210 D02 Signal Boosters Certification v01r01
Test Requirement:	
700MHz Lower ABC Band	FCC part 27. 53 The power of any emission outside a licensee's frequency block shall be attenuated below the transmitting power (P) by at least $43 + 10 \log (P)$ dB, or -13 dBm.
700MHz Upper C Band	FCC part 27. 53 The power of any emission outside a licensee's frequency block shall be attenuated below the transmitting power (P) by at least $43 + 10 \log (P)$ dB, or -13 dBm.
850MHz Band	FCC part 22. 917 The power of any emission outside a licensee's frequency block shall be attenuated below the transmitting power (P) by at least $43 + 10 \log (P)$ dB, or -13 dBm.
1900MHz Broadband PCS	FCC part 24. 238 The power of any emission outside a licensee's frequency block shall be attenuated below the transmitter power (P) by a factor of at least $43 + 10 \log (P)$ dB, or -13 dBm.
AWS-1 Band	FCC part 27. 53 The power of any emission outside a licensee's frequency block shall be attenuated below the transmitter power (P) by at least $43 + 10 \log (P)$ dB, or -13 dBm.
EUT Operation:	The output power of EUT be set to maximum value, the gain of EUT be set to maximum value by software through the manufacture
Test conditions:	Normal conditions

Test configuration:

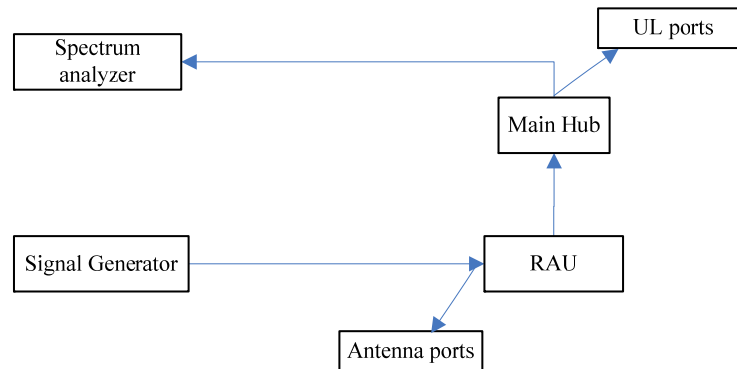
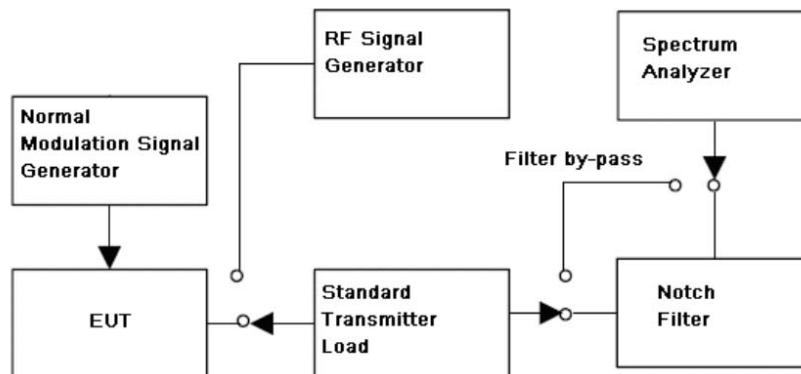

Figure 2: Uplink Conducted Spurious Emission Configuration



Test Procedure:

Conducted Emission test procedure:

- a) Connect the equipment as illustrated, with the notch filter by-passed, when the output power is over the max. value of the Spectrum Analyzer, add the attenuator to avoid destroying the facility.
- b) Set the center frequency of the Spectrum Analyzer to assigned transmitter frequency, key the transmitter, and set the level of the carrier to the full scale reference line.
- c) Do not apply any tone to modulate the EUT
- d) Adjust the Spectrum Analyzer for the following setting:
  - 1) Resolution Bandwidth (base the standard, apply the different set), her is 100kHz for frequency band less than 1 GHz, 1 MHz for frequency over 1 GHz
  - 2) Video Bandwidth refer to standard requirement
- e) Adjust the center frequency of the spectrum analyzer for incremental coverage of the range from:
  - 1) the lowest radio frequency generated in the equipment, it can be 9 kHz base the test method, here select 30 MHz

as lowest frequency start point;

2) the highest radio frequency shall higher than 10 times of carrier frequency;

f) Record the frequencies and levels of spurious emissions;

Remark:

The notch filter is used for avoid the EUT fundamental carrier output power making the spectrum overload and the harmonic spurious brought by it.

When the EUT fundamental carrier is not enough to make the status, the notch filter could be not used.

### 5.3.2.1 Measurement Record

#### 5.3.2.1.1 700MHz Lower ABC Band for Uplink

##### 1) 700MHz Lower A

##### 1.1) Test for LTE 1.4MHz

(a) Lowest frequency: 9 kHz to 1 GHz

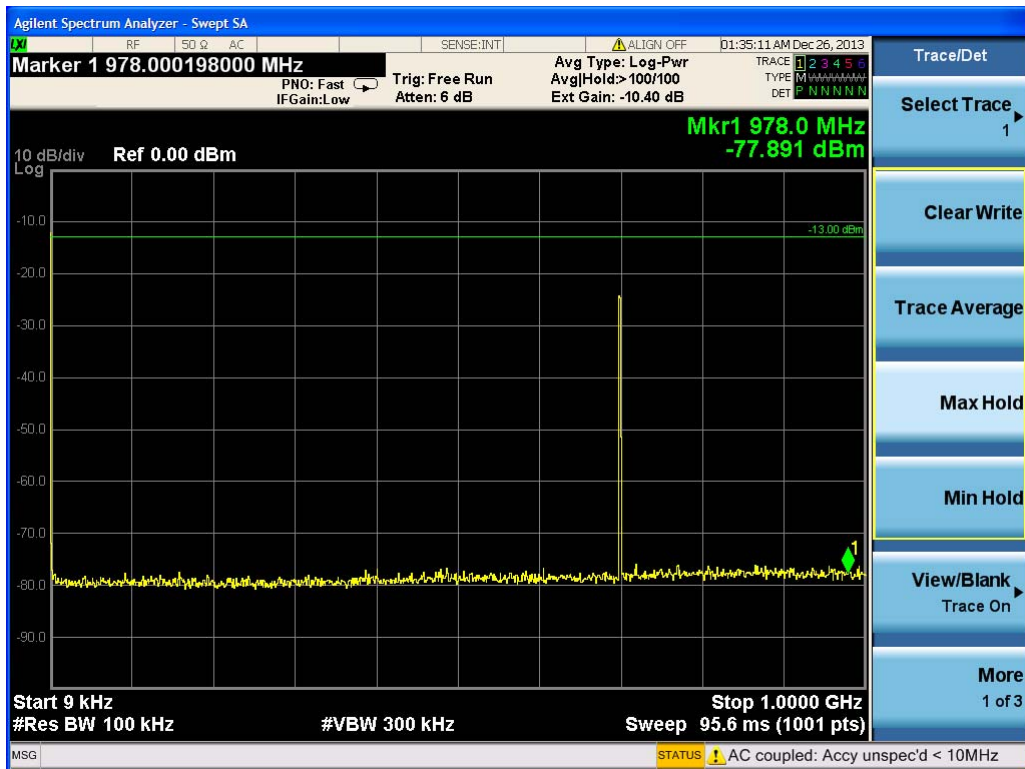

(b) Lowest frequency: 1 GHz to 12.75 GHz

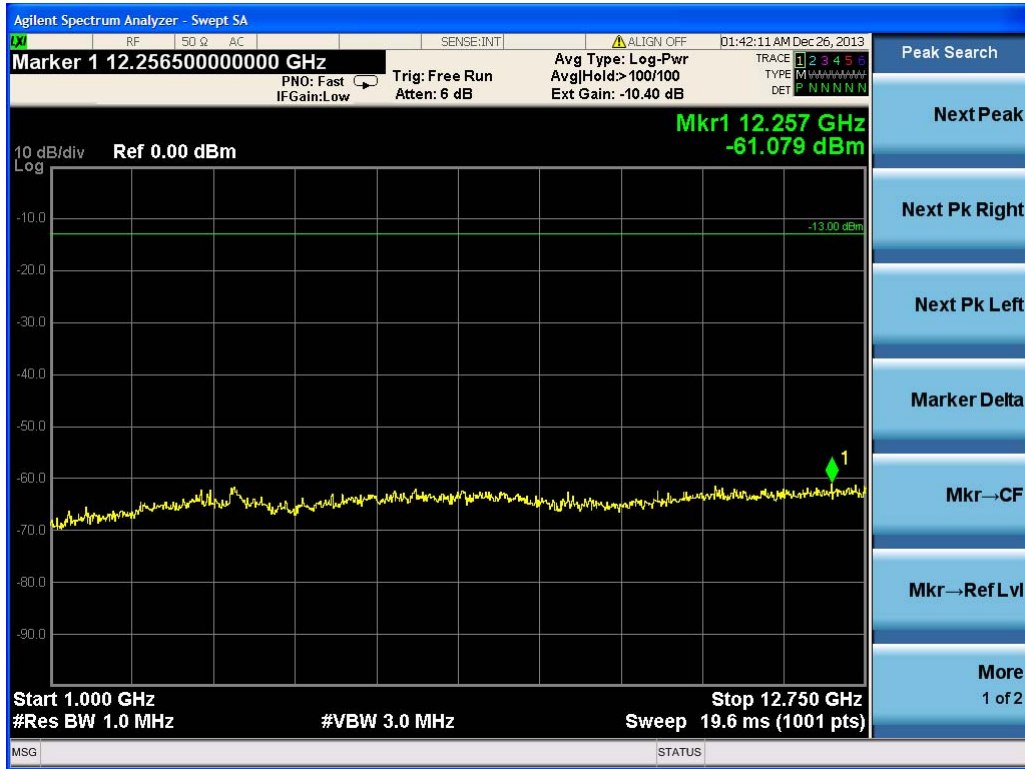

(c) Middle frequency: 9 kHz to 1 GHz

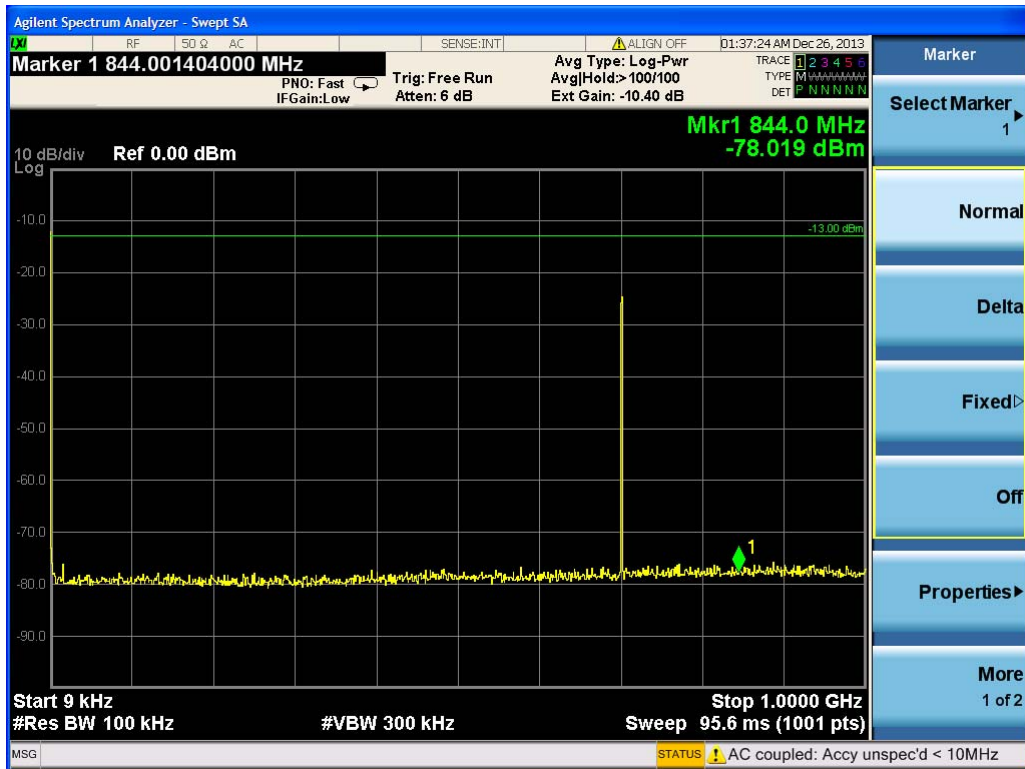



(d) Middle frequency: 1 GHz to 12.75 GHz



(e) Highest frequency: 9 kHz to 1 GHz

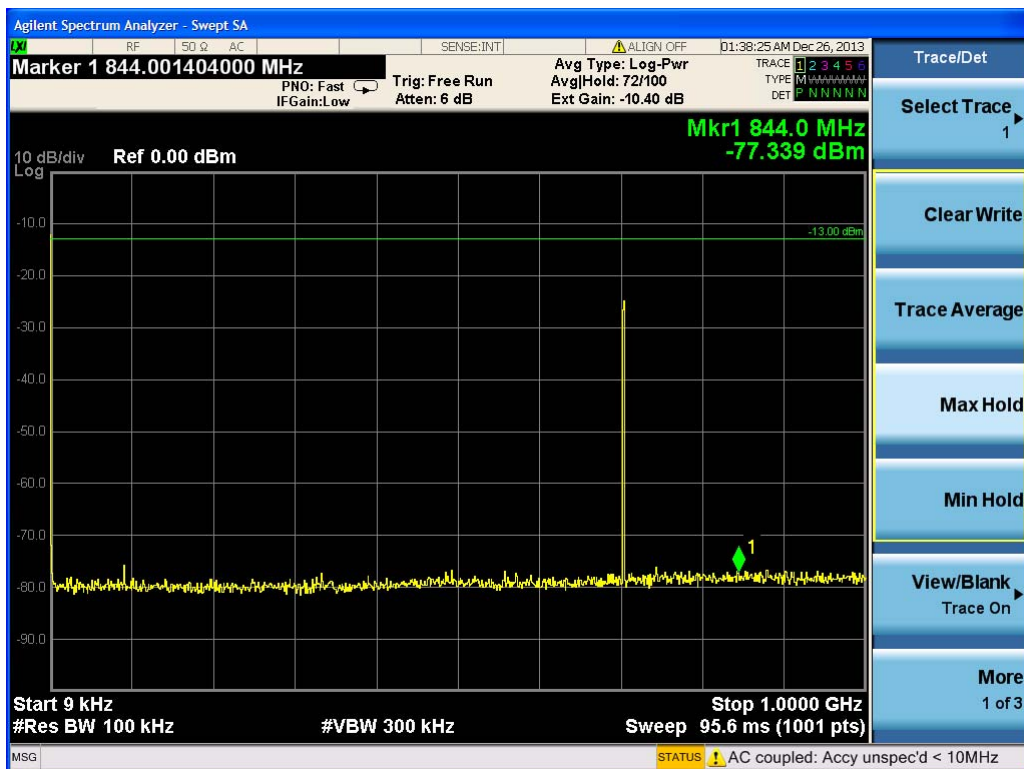

(f) Highest frequency: 1 GHz to 12.75 GHz



### 1.2) Test for LTE 5MHz

(a) Lowest frequency: 9 kHz to 1 GHz

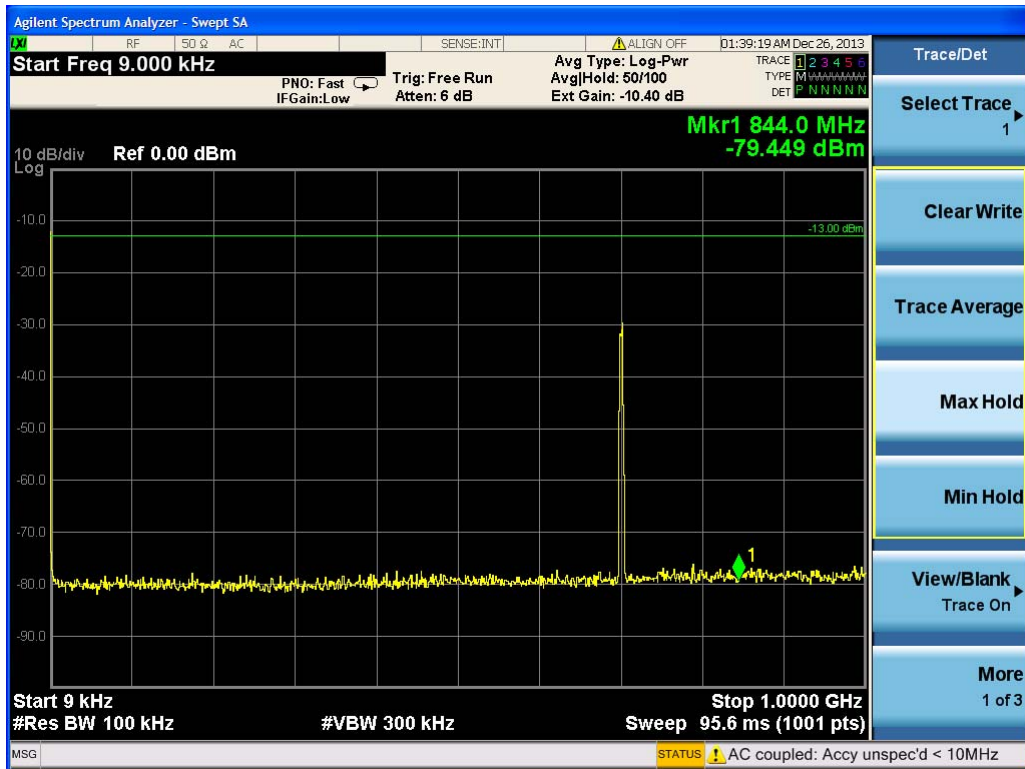

(b) Lowest frequency: 1 GHz to 12.75 GHz

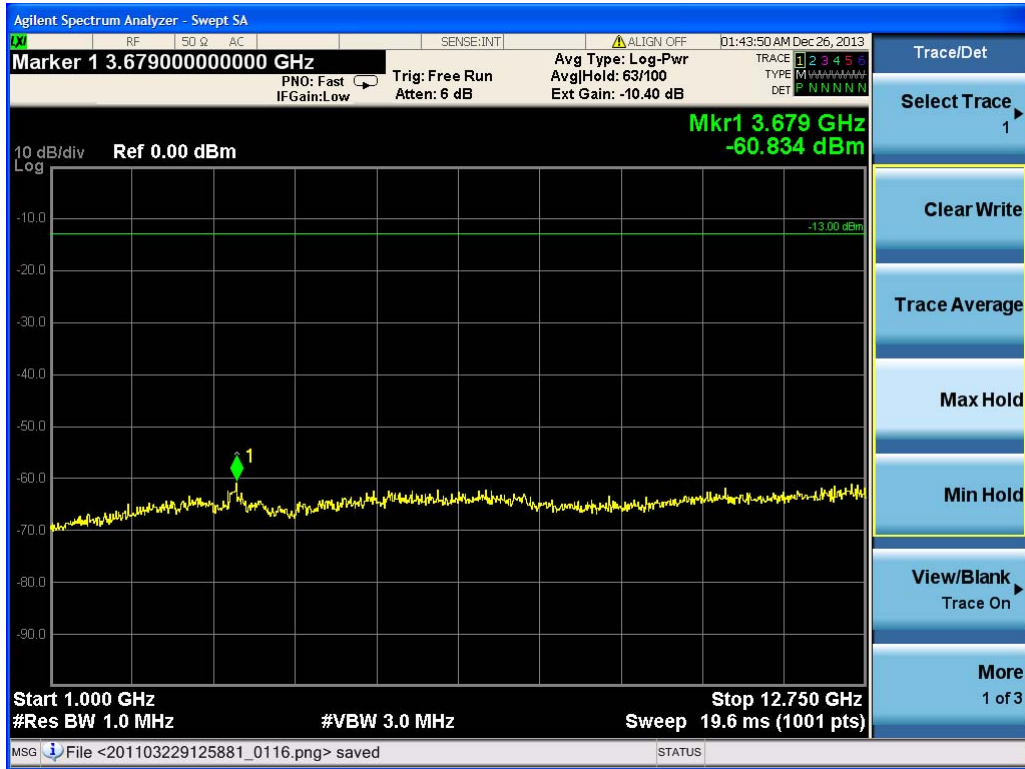

(c) Middle frequency: 9 kHz to 1 GHz

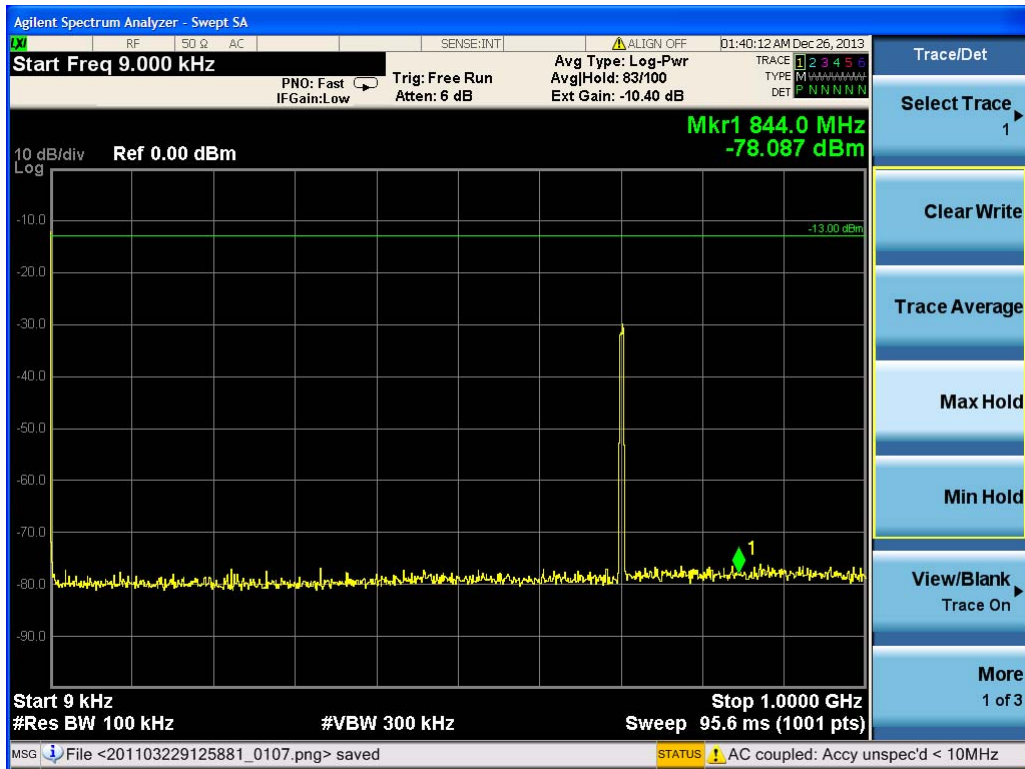

(d) Middle frequency: 1 GHz to 12.75 GHz

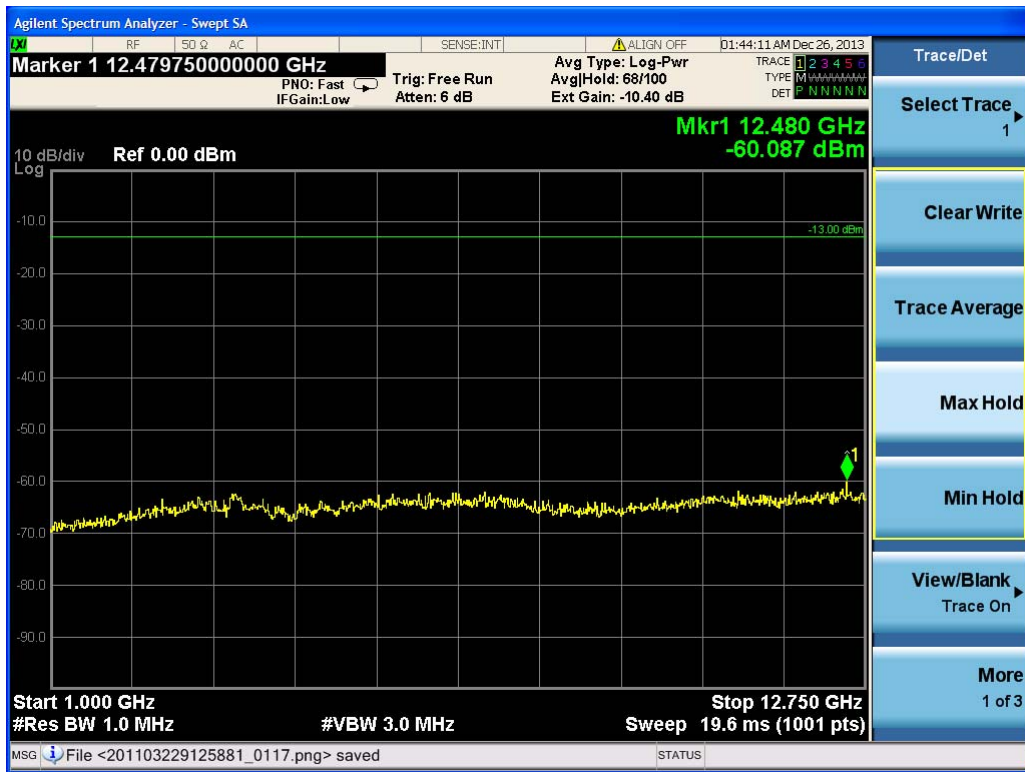

(e) Highest frequency: 9 kHz to 1 GHz

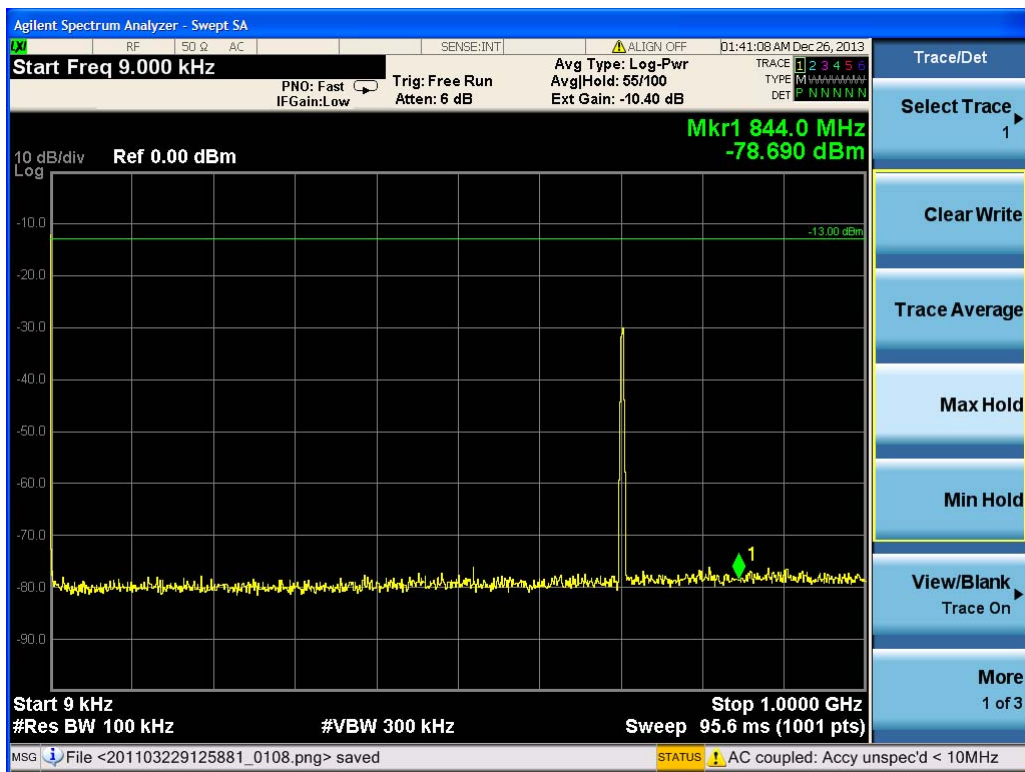

(f) Highest frequency: 1 GHz to 12.75 GHz

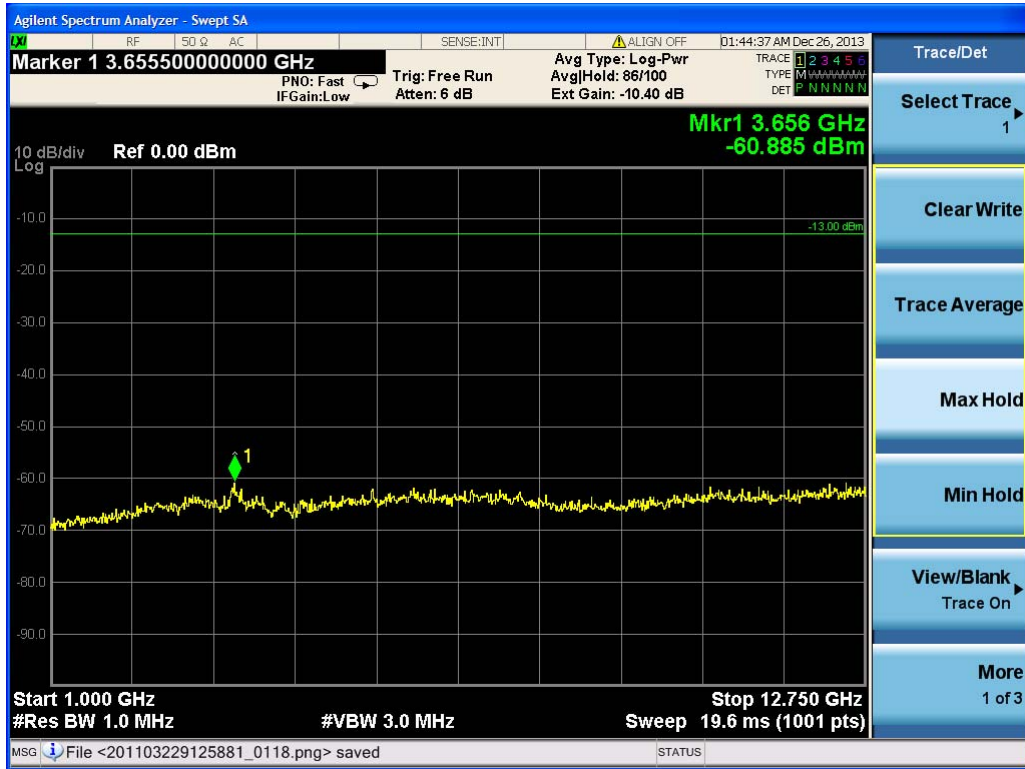



## 2) 700MHz Lower B

### 2.1) Test for LTE 1.4MHz

(a) Lowest frequency: 9 kHz to 1 GHz

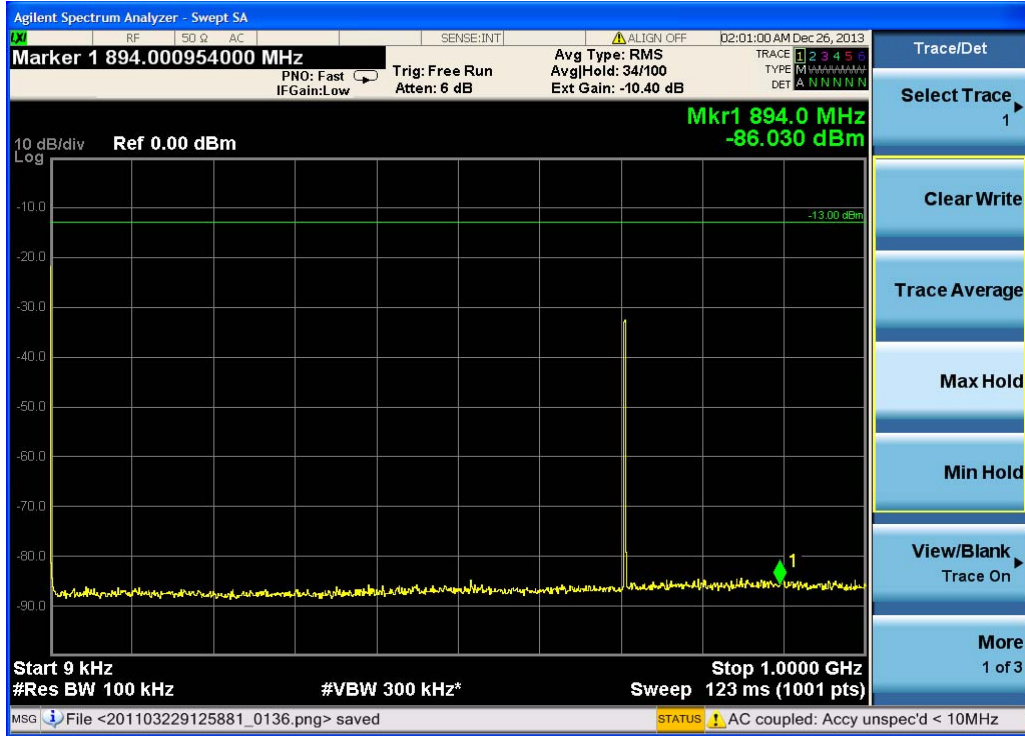

(b) Lowest frequency: 1 GHz to 12.75 GHz

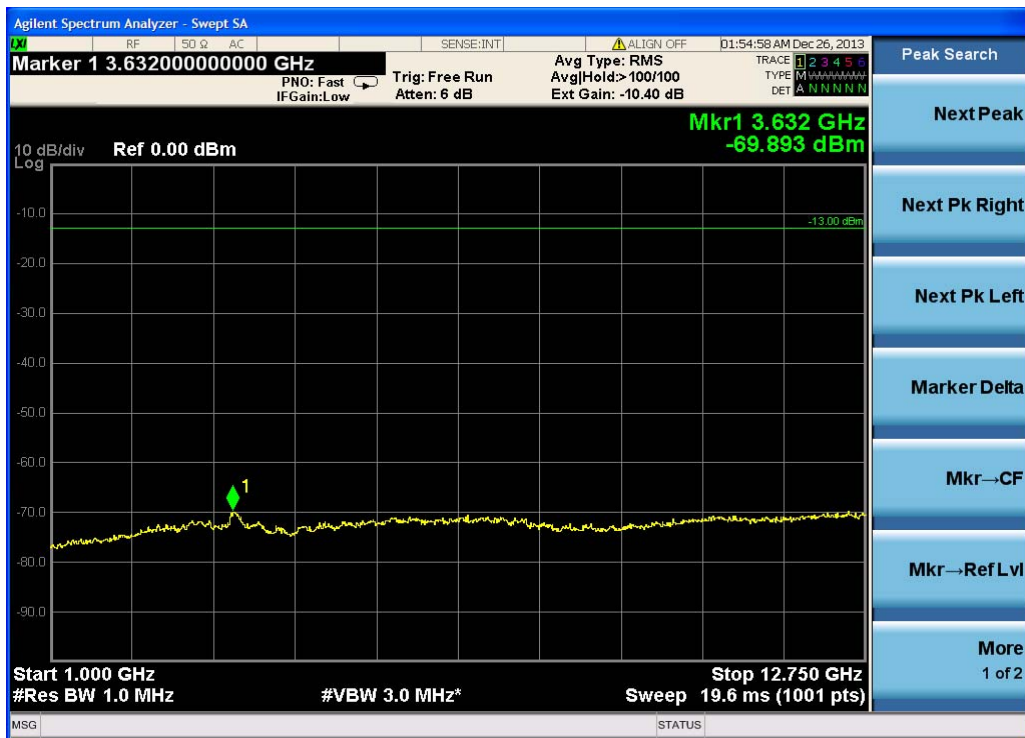

(c) Middle frequency: 9 kHz to 1 GHz

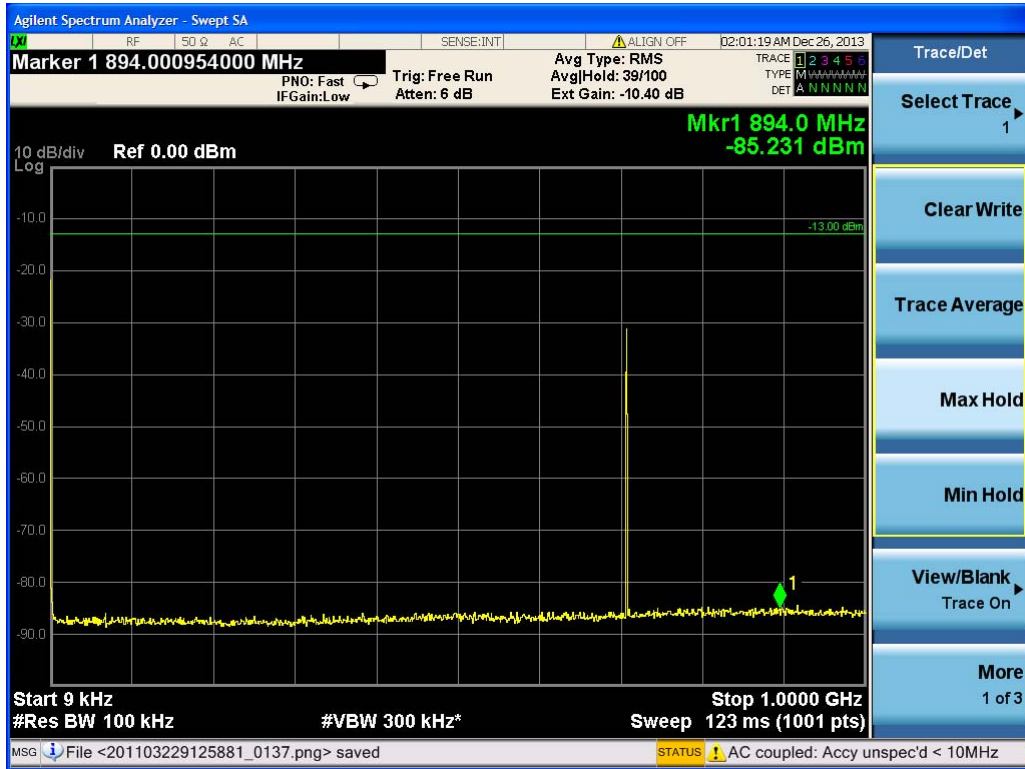

(d) Middle frequency: 1 GHz to 12.75 GHz

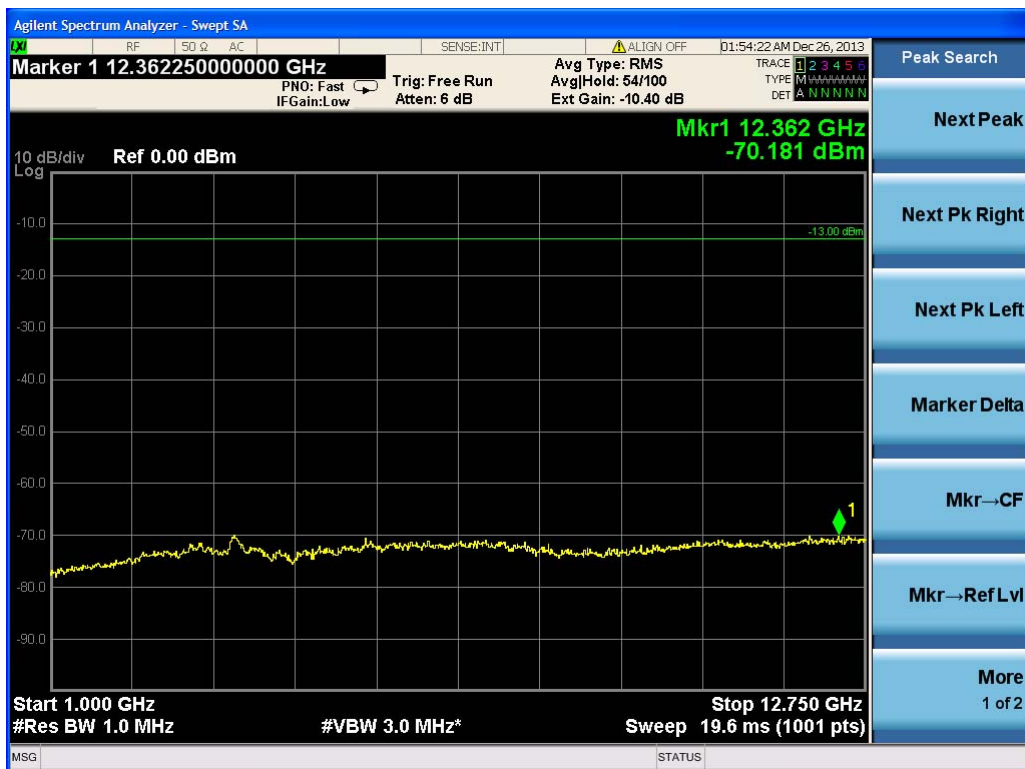

(e) Highest frequency: 9 kHz to 1 GHz

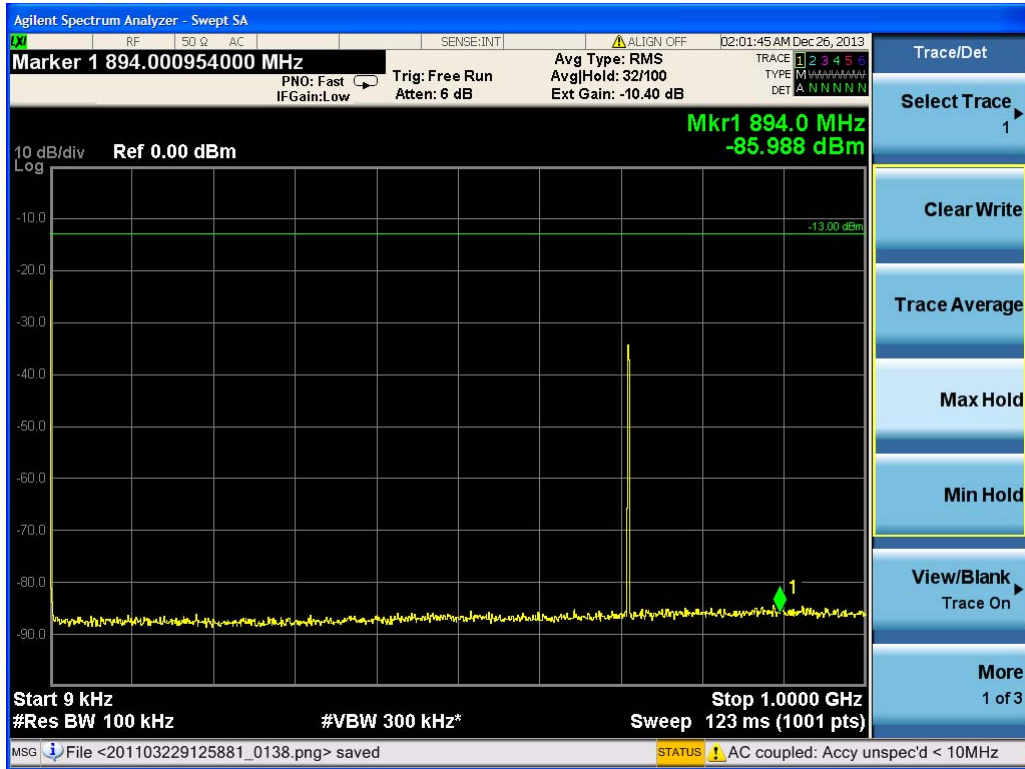

(f) Highest frequency: 1 GHz to 12.75 GHz

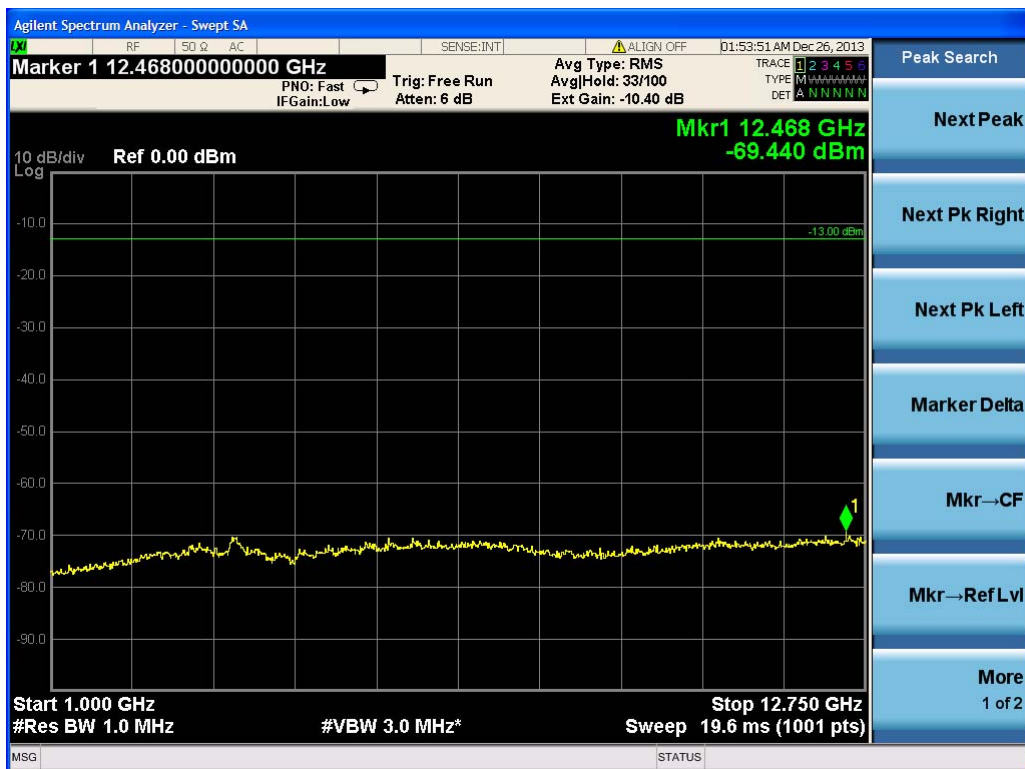



## 2.2) Test for LTE 5MHz

(a) Lowest frequency: 9 kHz to 1 GHz

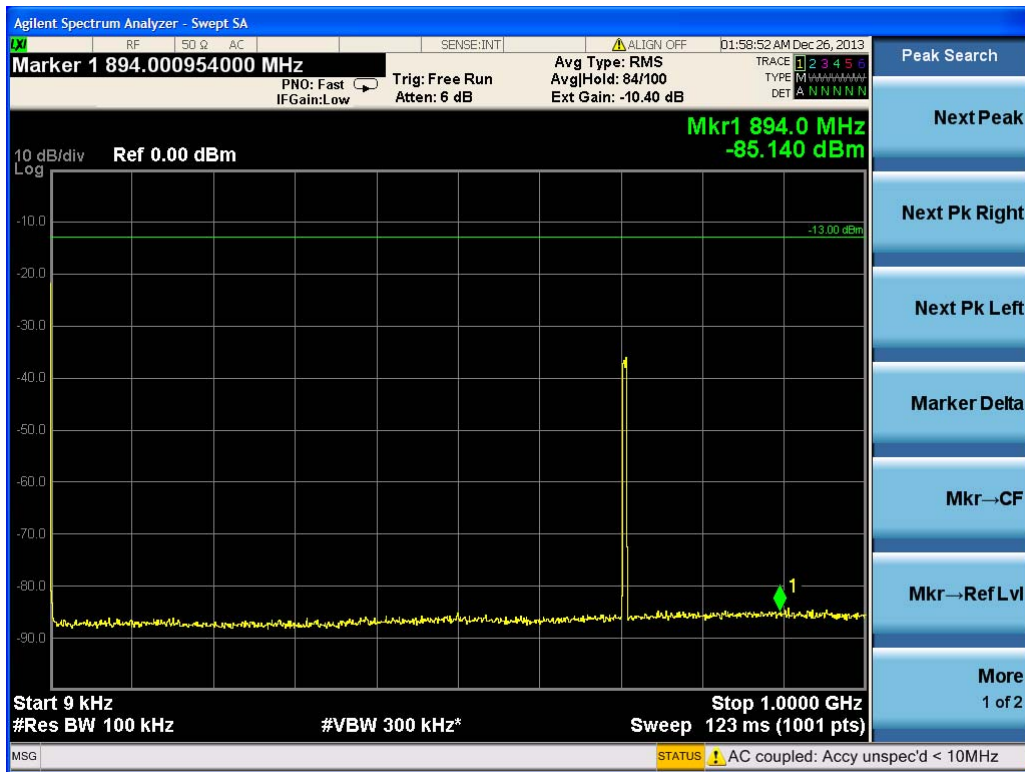

(b) Lowest frequency: 1 GHz to 12.75 GHz

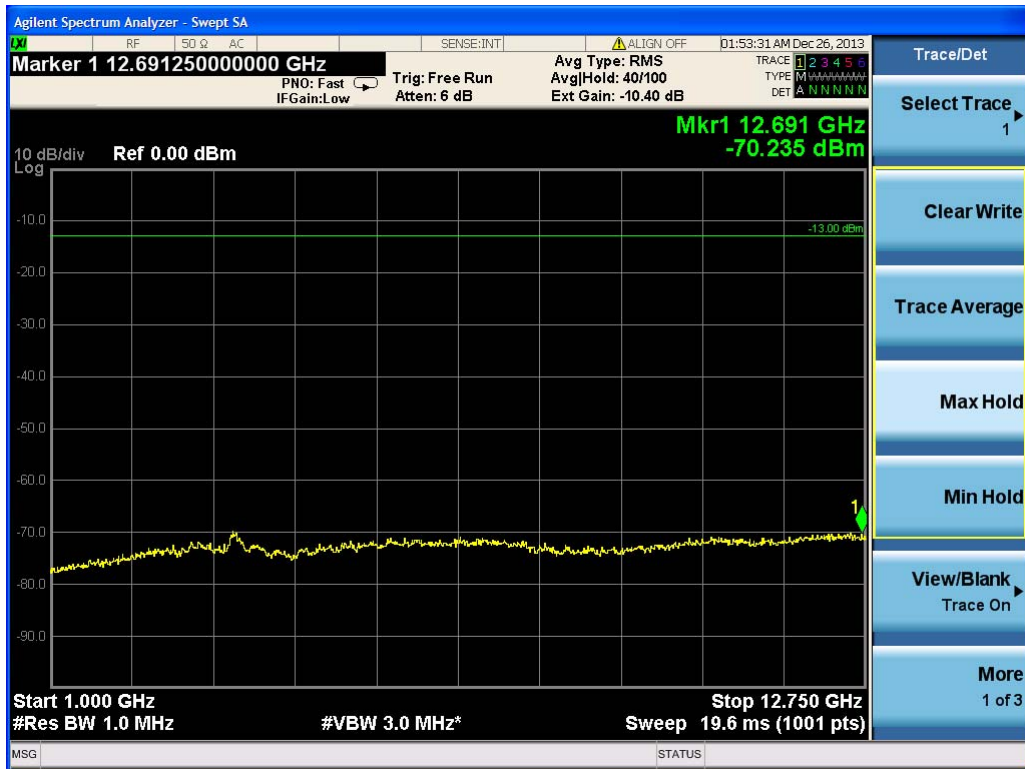

(c) Middle frequency: 9 kHz to 1 GHz

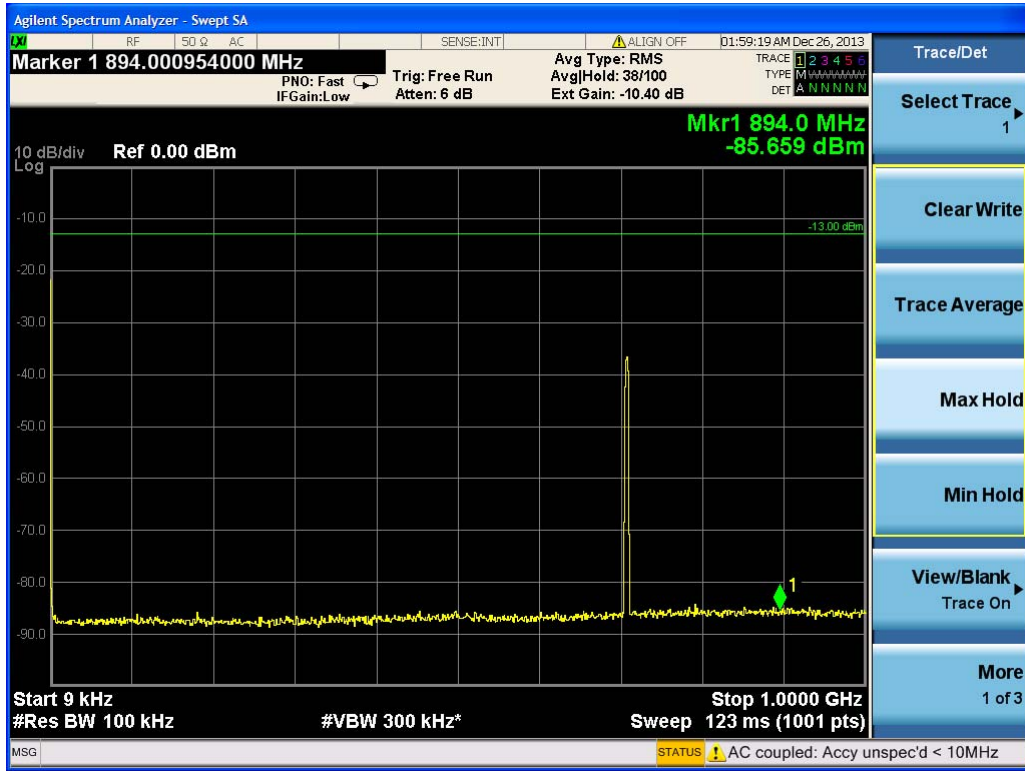

(d) Middle frequency: 1 GHz to 12.75 GHz

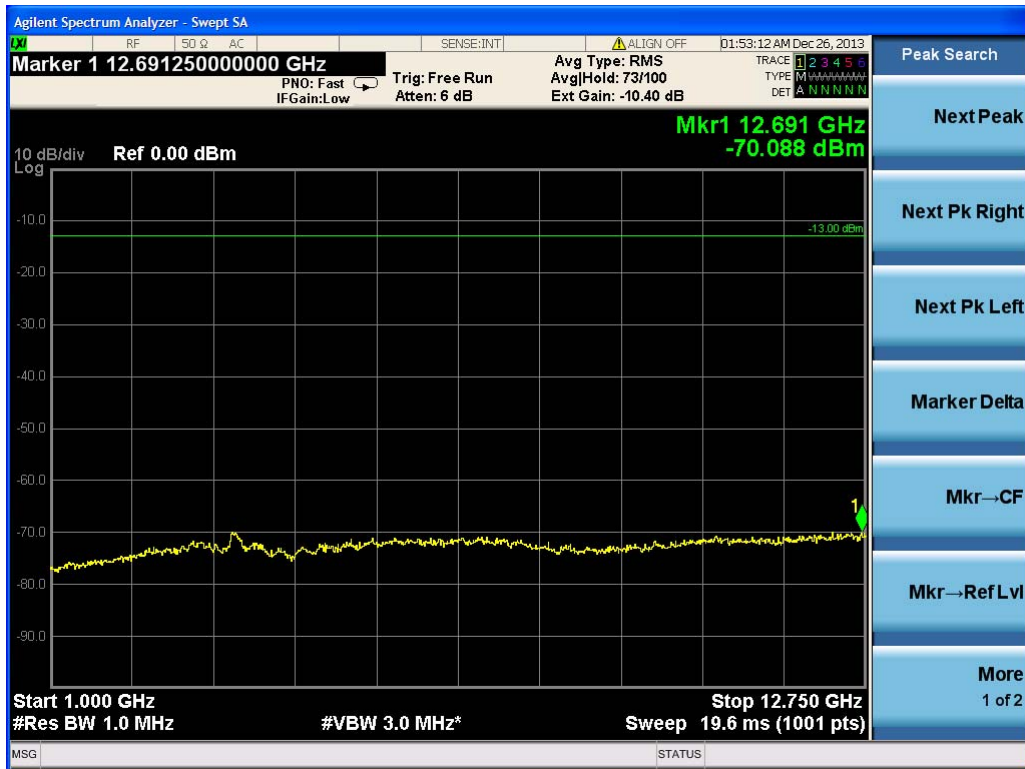

(e) Highest frequency: 9 kHz to 1 GHz

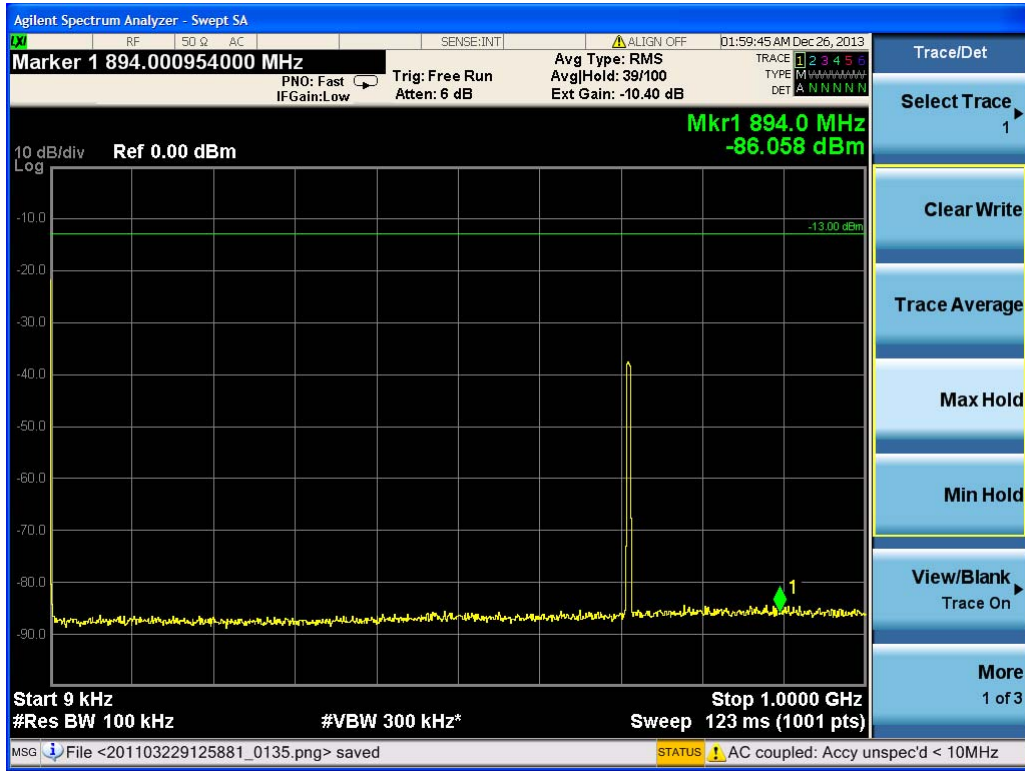

(f) Highest frequency: 1 GHz to 12.75 GHz

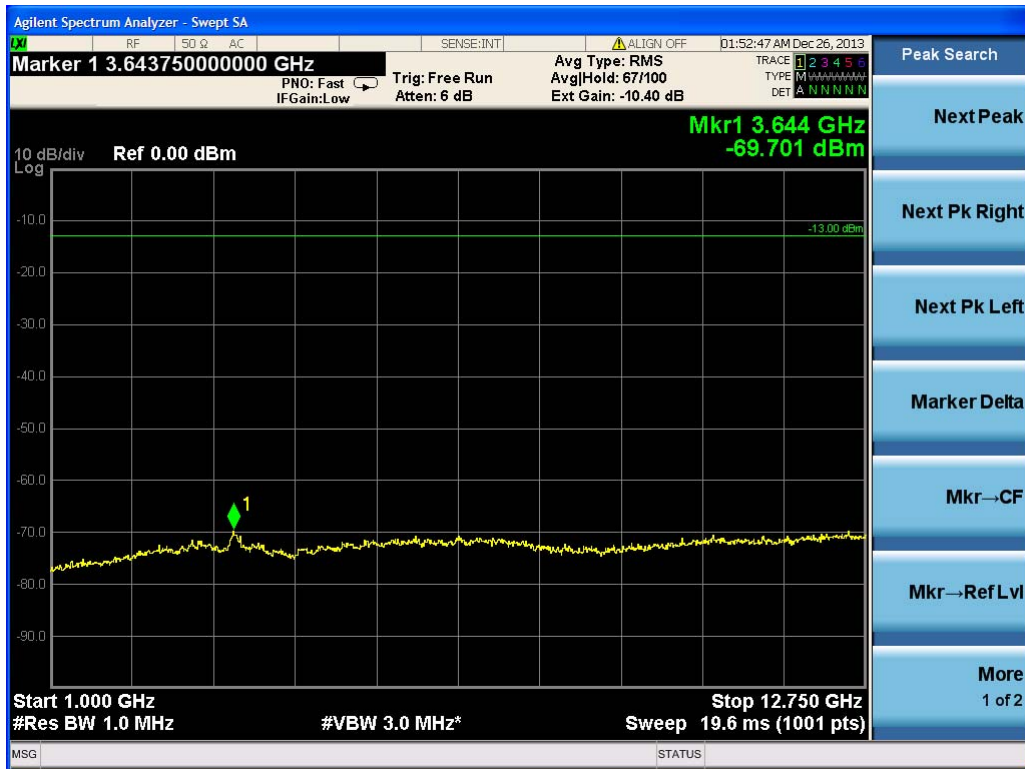

### 3) 700MHz Lower C

#### 3.1) Test for LTE 1.4MHz

(a) Lowest frequency: 9 kHz to 1 GHz

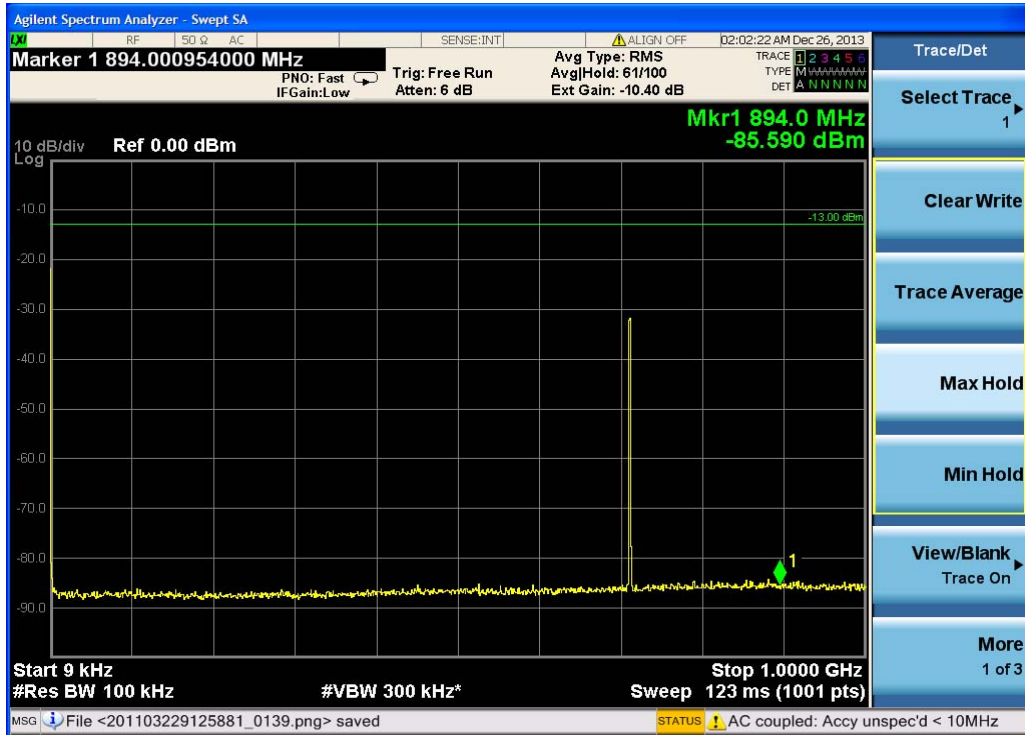

(b) Lowest frequency: 1 GHz to 12.75 GHz

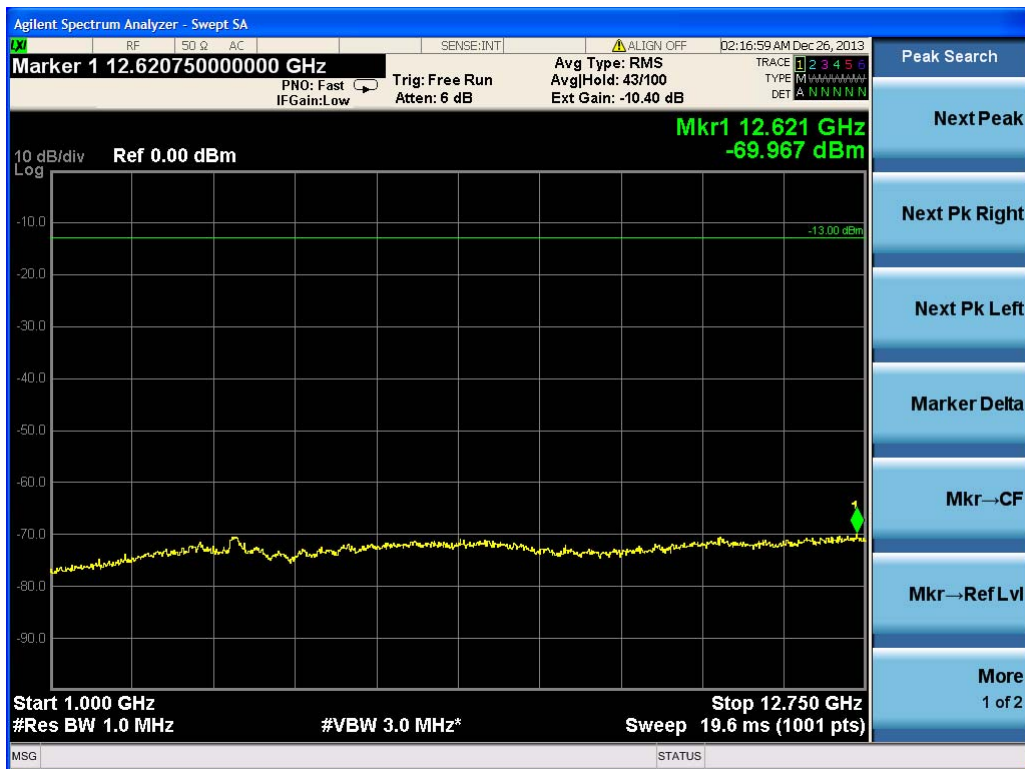

(c) Middle frequency: 9 kHz to 1 GHz

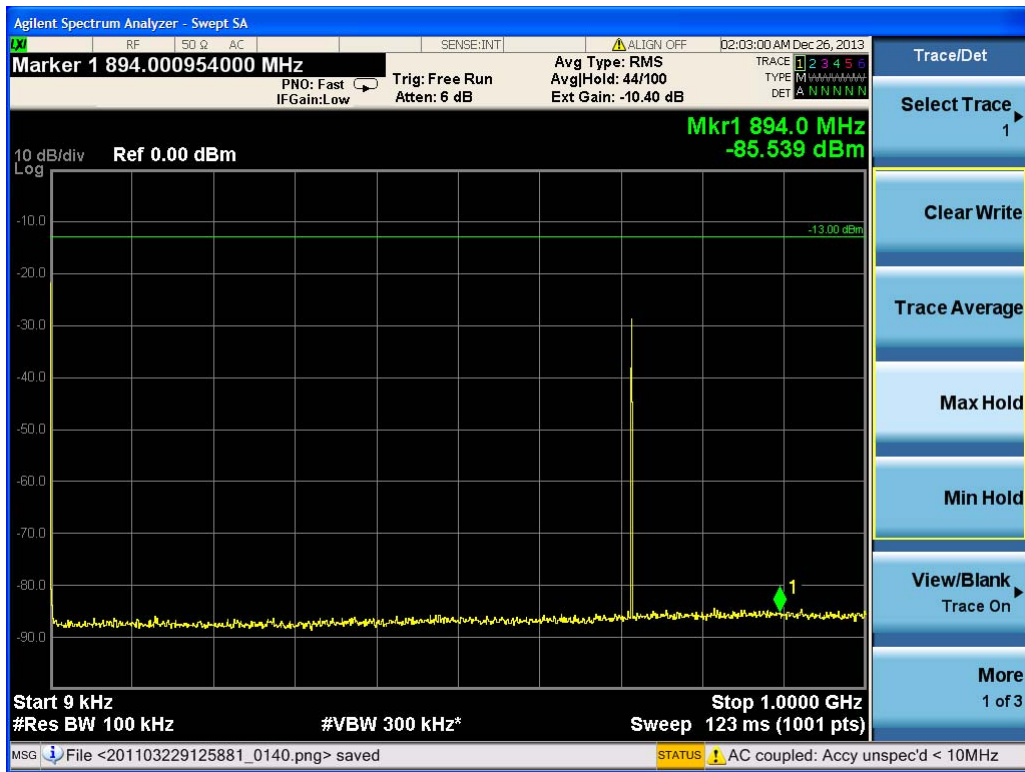

(d) Middle frequency: 1 GHz to 12.75 GHz

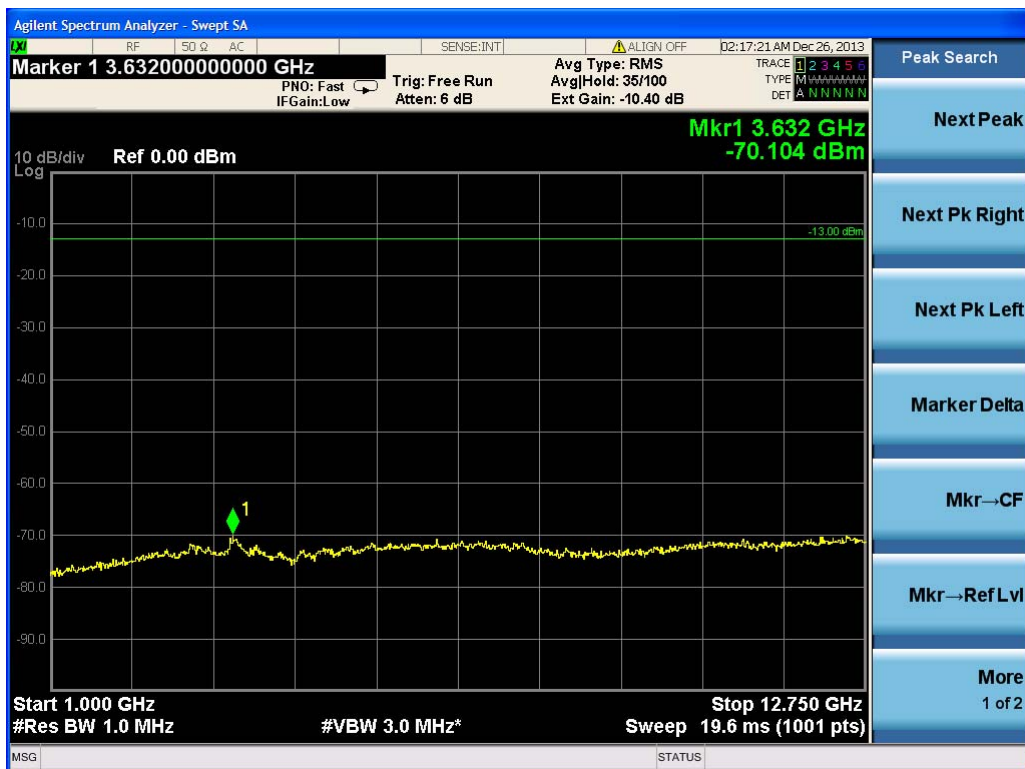



(e) Highest frequency: 9 kHz to 1 GHz

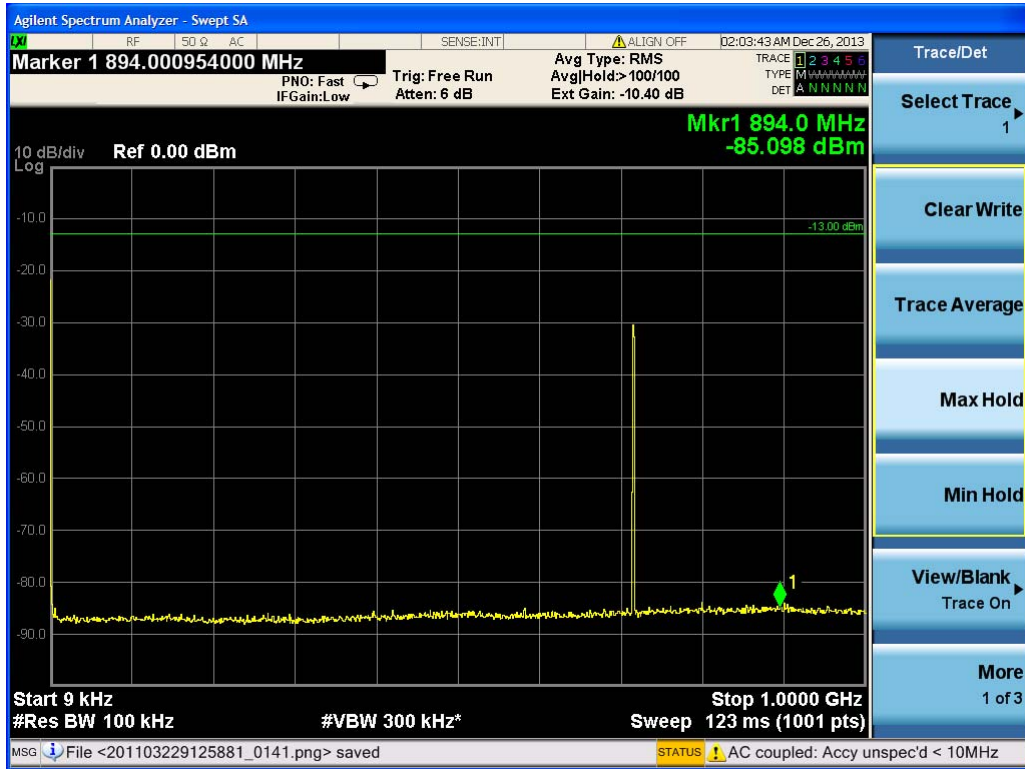

(f) Highest frequency: 1 GHz to 12.75 GHz

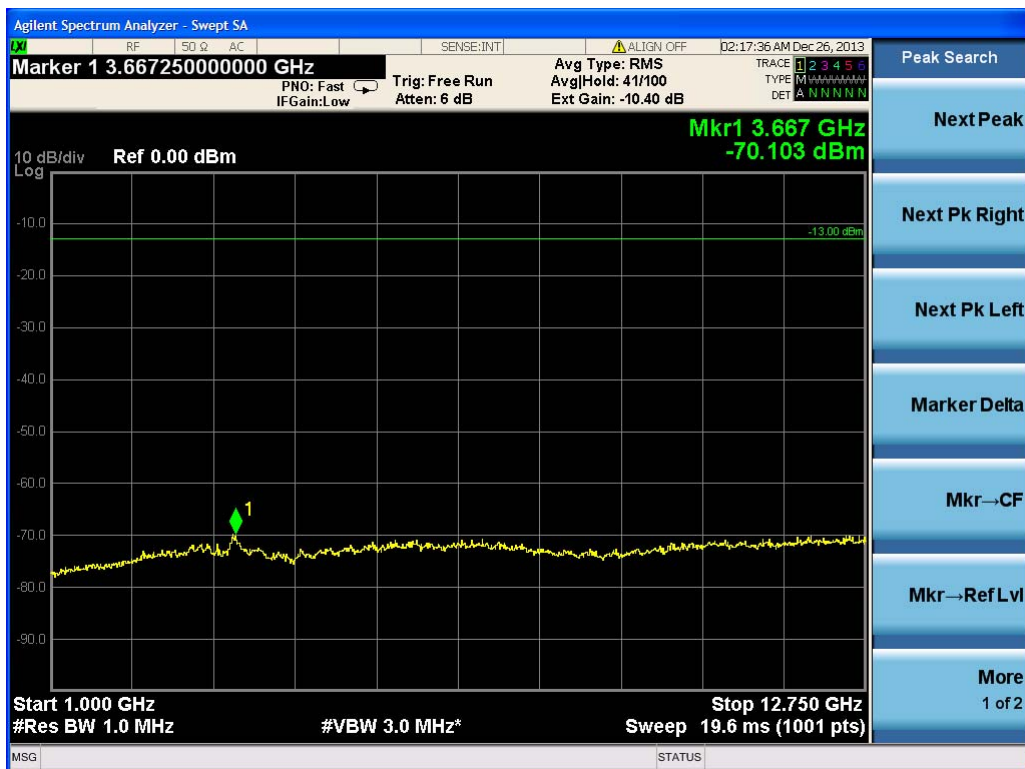

### 3.2) Test for LTE 5MHz

(a) Lowest frequency: 9 kHz to 1 GHz

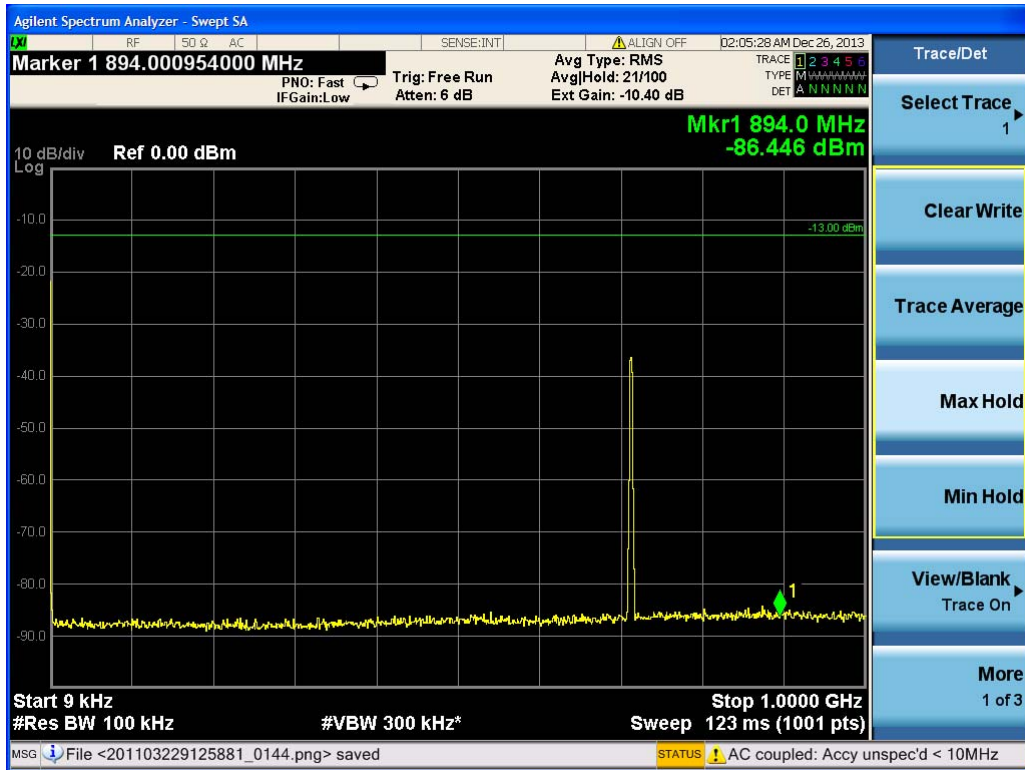

(b) Lowest frequency: 1 GHz to 12.75 GHz

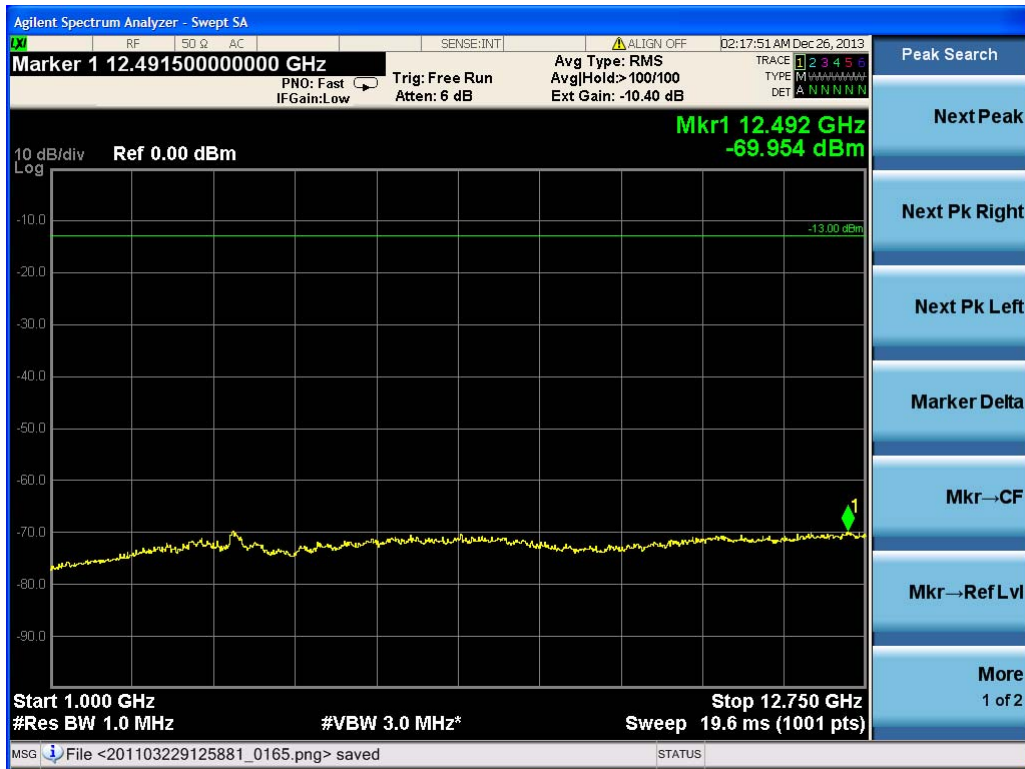

(c) Middle frequency: 9 kHz to 1 GHz

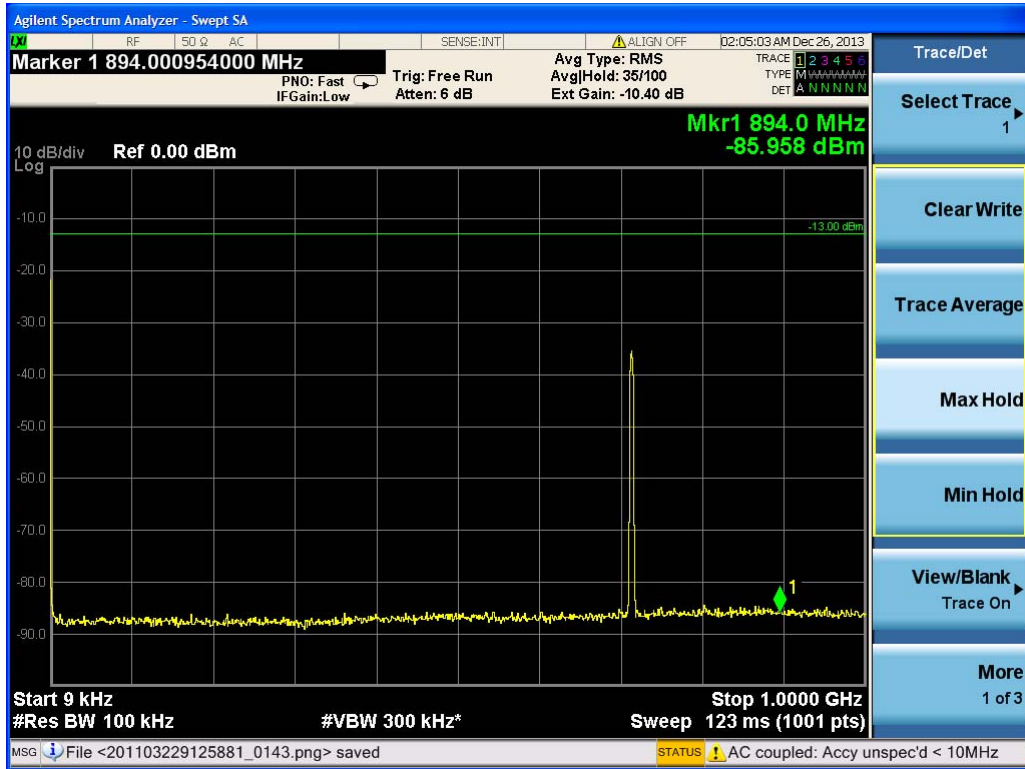

(d) Middle frequency: 1 GHz to 12.75 GHz

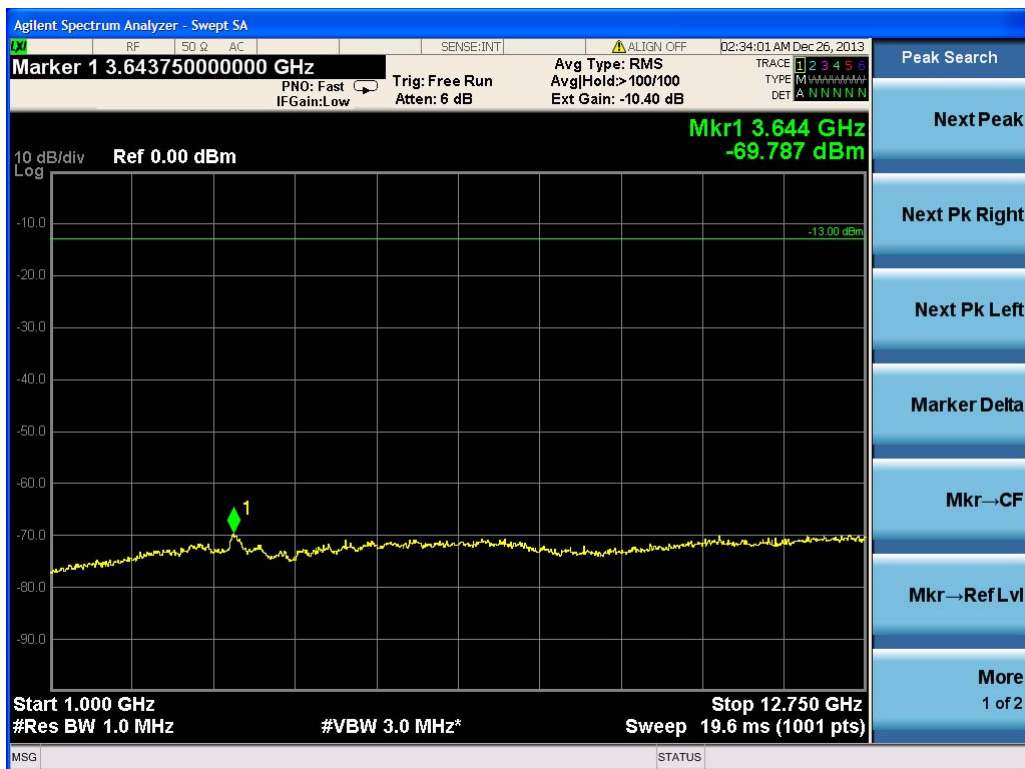



(e) Highest frequency: 9 kHz to 1 GHz

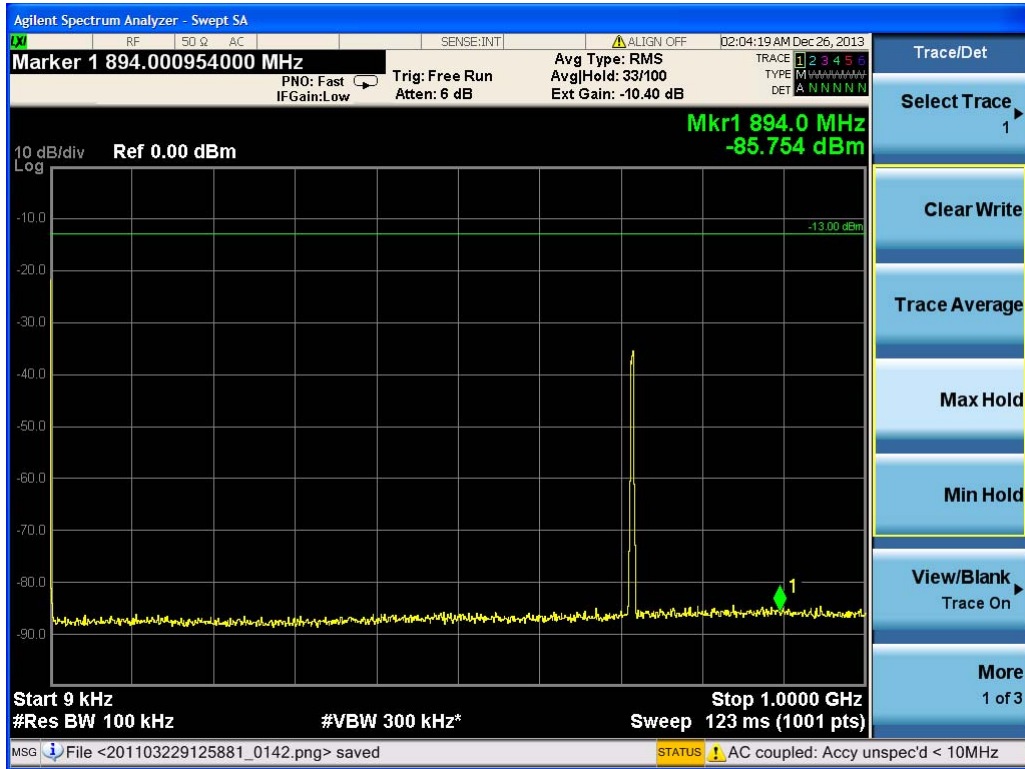

(f) Highest frequency: 1 GHz to 12.75 GHz

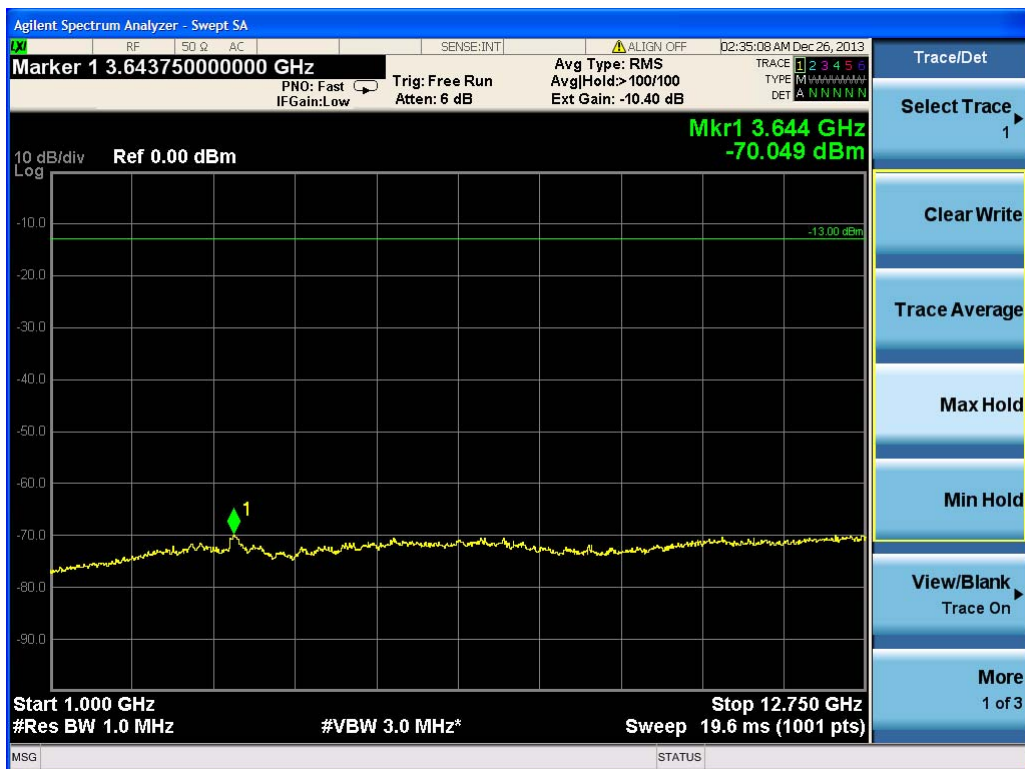

#### 4) 700MHz LowerABC full band

##### 4.1) Test for LTE 10MHz

(a) Lowest frequency: 9 kHz to 1 GHz

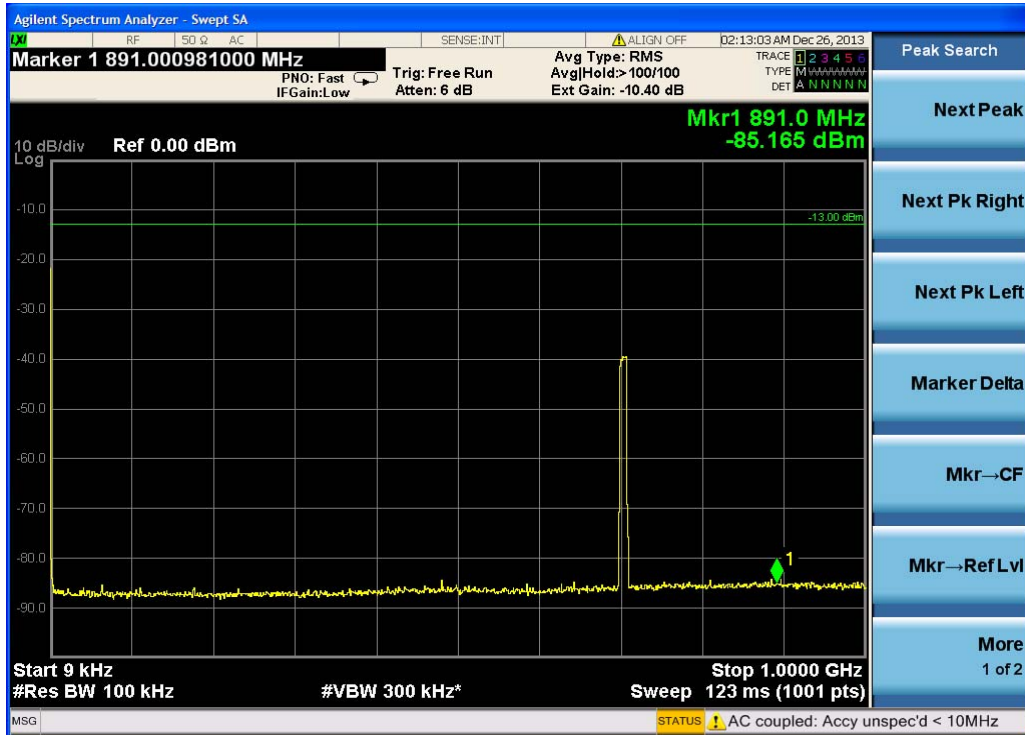

(b) Lowest frequency: 1 GHz to 12.75 GHz

