



For CDMA mode:

**3.5.3 Input frequency:**

1) in lower edge test: f1 is the lower edge frequency +1 channel frequency, and f2 is +2 channel frequency

$$f1=1930\text{MHz}, f2=1932\text{MHz}$$

2) in higher edge test: f1 is the higher edge frequency -2 channel frequency, and f2 is -1 channel frequency

$$f1=1991\text{MHz}, f2=1993\text{MHz}$$

base the 3<sup>rd</sup> product frequency  $F1=2f1-f2$  and  $F2=2f2-f1$ , when the f1 and f2 frequency select above,

- o) in lower edge test,  $F1=2f1-(f1+\Delta f)=f1-\Delta f$ =lower edge frequency;
- p) in higher edge test,  $F2=2f2-(f2-\Delta f)=f2+\Delta f$ =higher edge frequency.

$$F1=1930\text{MHz}, F2=1995\text{MHz}$$

base the 5<sup>rd</sup> product frequency  $F1=3f1-2f2$  and  $F2=3f2-2f1$ , when the f1 and f2 frequency select above,

- o) in lower edge test,  $F1=3f1-2(f1+\Delta f)=f1-2\Delta f$ =lower edge frequency;
- p) in higher edge test,  $F2=3f2-2(f2-\Delta f)=f2+2\Delta f$ =higher edge frequency.

$$F1=1928\text{MHz}, F2=1997\text{MHz}$$

base the 7<sup>rd</sup> product frequency  $F1=4f1-3f2$  and  $F2=4f2-3f1$ , when the f1 and f2 frequency select above,

- o) in lower edge test,  $F1=4f1-3(f1+\Delta f)=f1-3\Delta f$ =lower edge frequency;
- p) in higher edge test,  $F2=4f2-3(f2-\Delta f)=f2+3\Delta f$ =higher edge frequency.

$$F1=1926\text{MHz}, F2=1999\text{MHz}$$

**3.5.4 Input power:-20dBm**

measure frequency		product Value (dBm)	Limit (dBm)	Magin (dB)
3 <sup>rd</sup>	Lower:1930MHz	-22.45	-13dBm	-9.45
	Higher:1995MHz	-23.16		-10.16
5 <sup>rd</sup>	Lower:1928MHz	-26.75	-13dBm	-13.75
	Higher:1997MHz	-27.18		-14.18
7 <sup>rd</sup>	Lower:1926MHz	-31.73	-13dBm	-18.73
	Higher:1999MHz	-32.65		-19.65



For WCDMA mode:

**3.5.5 Input frequency:**

1) in lower edge test: f1 is the lower edge frequency +1 channel frequency, and f2 is +2 channel frequency

$$f1=1933\text{MHz}, f2=1936\text{MHz}$$

2) in higher edge test: f1 is the higher edge frequency -2 channel frequency, and f2 is -1 channel frequency

$$f1=1989\text{MHz}, f2=1992\text{MHz}$$

base the 3<sup>rd</sup> product frequency  $F1=2f1-f2$  and  $F2=2f2-f1$ , when the f1 and f2 frequency select above,

q) in lower edge test,  $F1=2f1-(f1+\Delta f)=f1-\Delta f$ =lower edge frequency;

r) in higher edge test,  $F2=2f2-(f2-\Delta f)=f2+\Delta f$ =higher edge frequency.

$$F1=1930\text{MHz}, F2=1995\text{MHz}$$

base the 5<sup>th</sup> product frequency  $F1=3f1-2f2$  and  $F2=3f2-2f1$ , when the f1 and f2 frequency select above,

q) in lower edge test,  $F1=3f1-2(f1+\Delta f)=f1-2\Delta f$ =lower edge frequency;

r) in higher edge test,  $F2=3f2-2(f2-\Delta f)=f2+2\Delta f$ =higher edge frequency.

$$F1=1927\text{MHz}, F2=1998\text{MHz}$$

base the 7<sup>th</sup> product frequency  $F1=4f1-3f2$  and  $F2=4f2-3f1$ , when the f1 and f2 frequency select above,

q) in lower edge test,  $F1=4f1-3(f1+\Delta f)=f1-3\Delta f$ =lower edge frequency;

r) in higher edge test,  $F2=4f2-3(f2-\Delta f)=f2+3\Delta f$ =higher edge frequency.

$$F1=1924\text{MHz}, F2=2001\text{MHz}$$

**3.5.6 Input power:-20dBm**

measure frequency		product Value (dBm)	Limit (dBm)	Magin (dB)
3 <sup>rd</sup>	Lower:1930MHz	-21.13	-13dBm	-8.13
	Higher:1995MHz	-20.43		-7.43
5 <sup>rd</sup>	Lower:1927MHz	-23.65	-13dBm	-10.65
	Higher:1998MHz	-24.81		-11.81
7 <sup>rd</sup>	Lower:1924MHz	-27.32	-13dBm	-14.32
	Higher:2001MHz	-26.89		-13.89

For LTE mode:

**3.5.7 Input frequency:**

1)in lower edge test:f1 is the lower edge frequency +1 channel frequency, and f2 is +2 channel frequency

$$f1=1935\text{MHz},f2=1945\text{MHz}$$

2)in higher edge test:f1 is the higher edge frequency -2 channel frequency, and f2 is -1 channel frequency

$$f1=1980\text{MHz},f2=1990\text{MHz}$$

base the 3<sup>rd</sup> product frequency  $F1=2f1-f2$  and  $F2=2f2-f1$ , when the f1 and f2 frequency select above,

s) in lower edge test,  $F1=2f1-(f1+\Delta f)=f1-\Delta f$ =lower edge frequency;

t) in higher edge test,  $F2=2f2-(f2-\Delta f)=f2+\Delta f$ =higher edge frequency.

$$F1=1930\text{MHz},F2=1995\text{MHz}$$

base the 5<sup>rd</sup> product frequency  $F1=3f1-2f2$  and  $F2=3f2-2f1$ , when the f1 and f2 frequency select above,

s) in lower edge test,  $F1=3f1-2(f1+\Delta f)=f1-2\Delta f$ =lower edge frequency;

t) in higher edge test,  $F2=3f2-2(f2-\Delta f)=f2+2\Delta f$ =higher edge frequency.

$$F1=1920\text{MHz},F2=2005\text{MHz}$$

base the 7<sup>rd</sup> product frequency  $F1=4f1-3f2$  and  $F2=4f2-3f1$ , when the f1 and f2 frequency select above,

s) in lower edge test,  $F1=4f1-3(f1+\Delta f)=f1-3\Delta f$ =lower edge frequency;

t) in higher edge test,  $F2=4f2-3(f2-\Delta f)=f2+3\Delta f$ =higher edge frequency.

$$F1=1910\text{MHz},F2=2015\text{MHz}$$

**3.5.8 Input power:-20dBm**

measure frequency		product Value (dBm)	Limit (dBm)	Magin (dB)
3 <sup>rd</sup>	Lower:1930MHz	-22.65	-13dBm	-9.65
	Higher:1995MHz	-21.87		-8.87
5 <sup>rd</sup>	Lower:1920MHz	-23.92	-13dBm	-10.92
	Higher:2005MHz	-24.76		-11.76
7 <sup>rd</sup>	Lower:1920MHz	-28.21	-13dBm	-15.21
	Higher:2015MHz	-27.92		-14.92

Remark:

No other intermodulation spurious emissioins of above 7<sup>rd</sup> have been found,so only record the test data about the 3<sup>rd</sup>, 5<sup>rd</sup>and 7<sup>rd</sup>

4. Downlink: 2110MHz to 2180MHz(CDMA,WCDMA,LTE)

4.1 CDMA Mode:

4.1.1 one signal input —Lower Edge

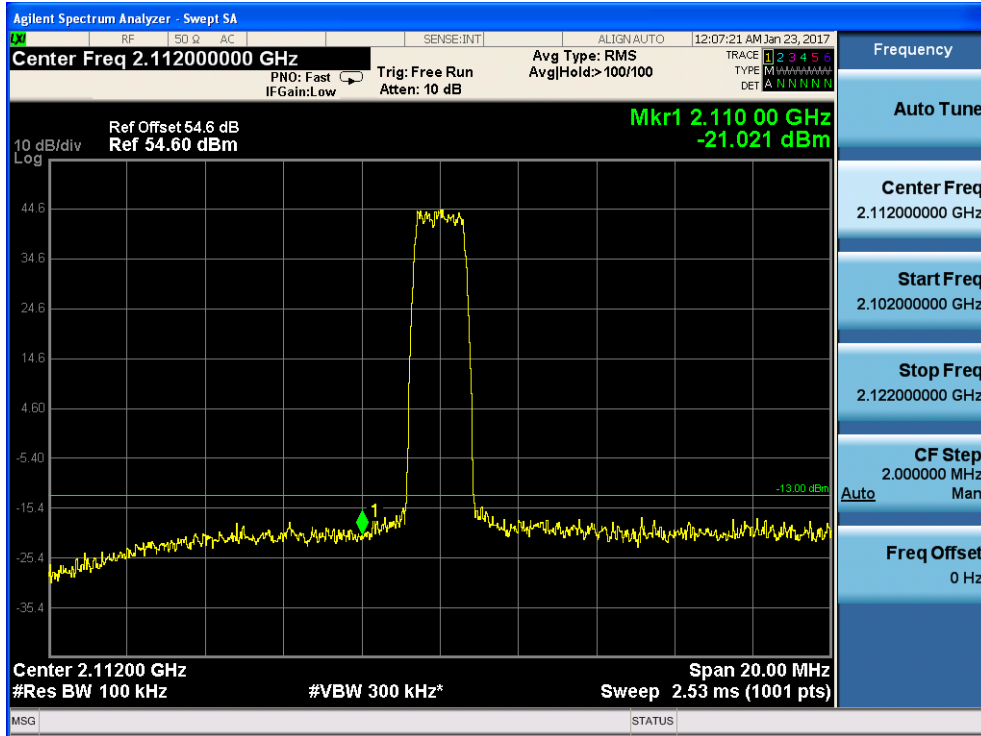

4.1.2 one signal input — Upper Edge

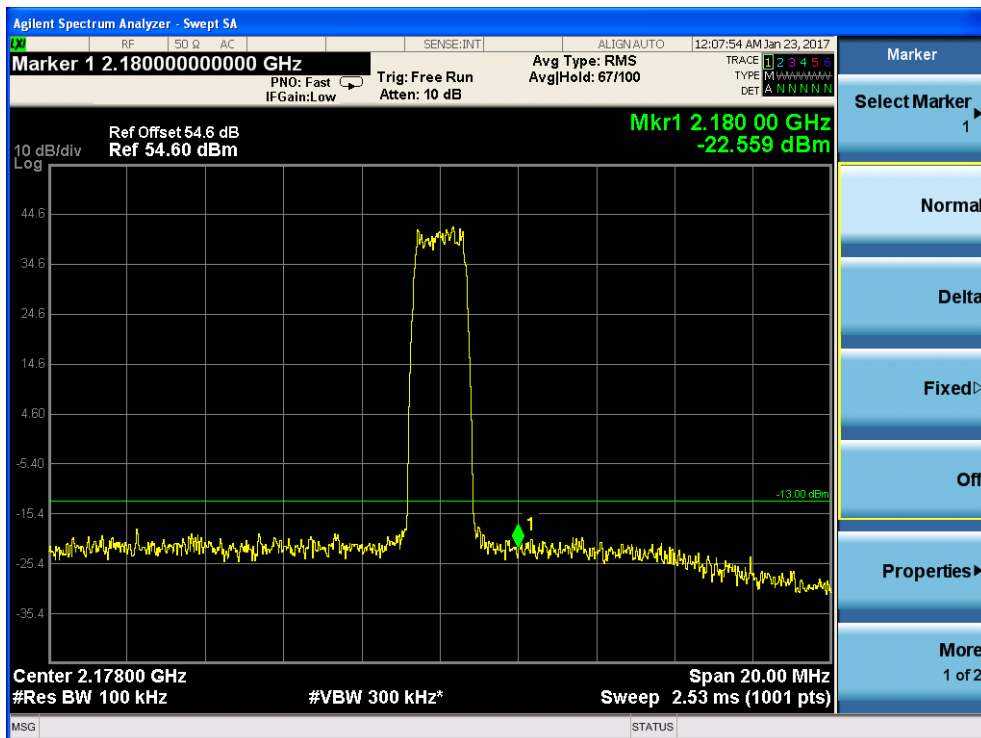

4.1.3 two signal input —Lower Edge

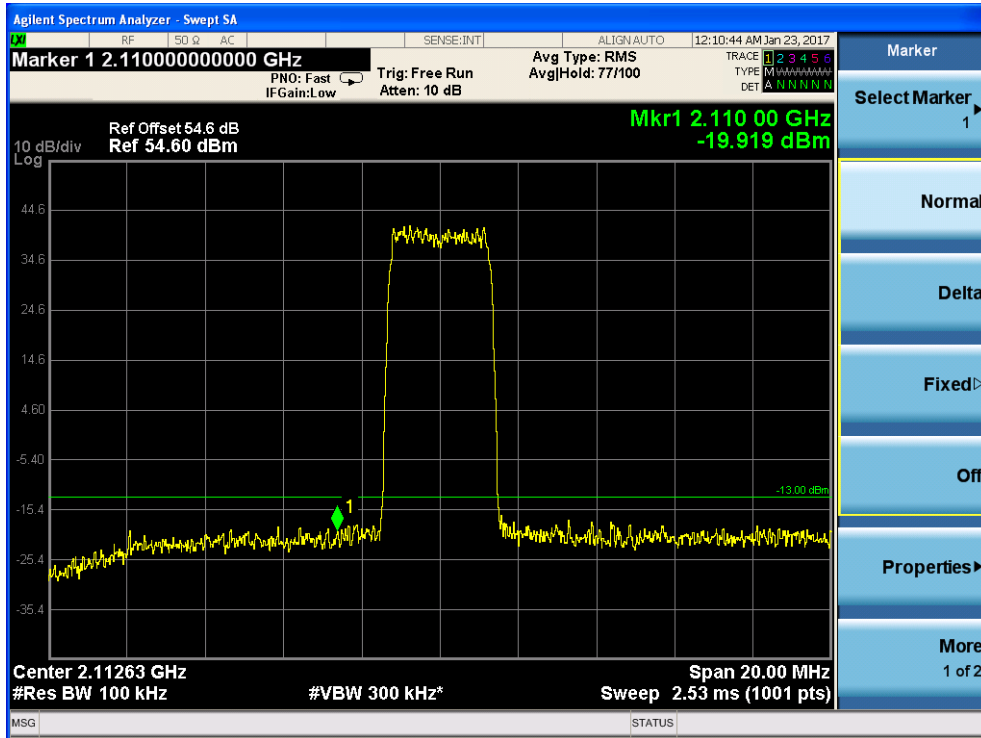

4.1.4 two signal input —Upper Edge

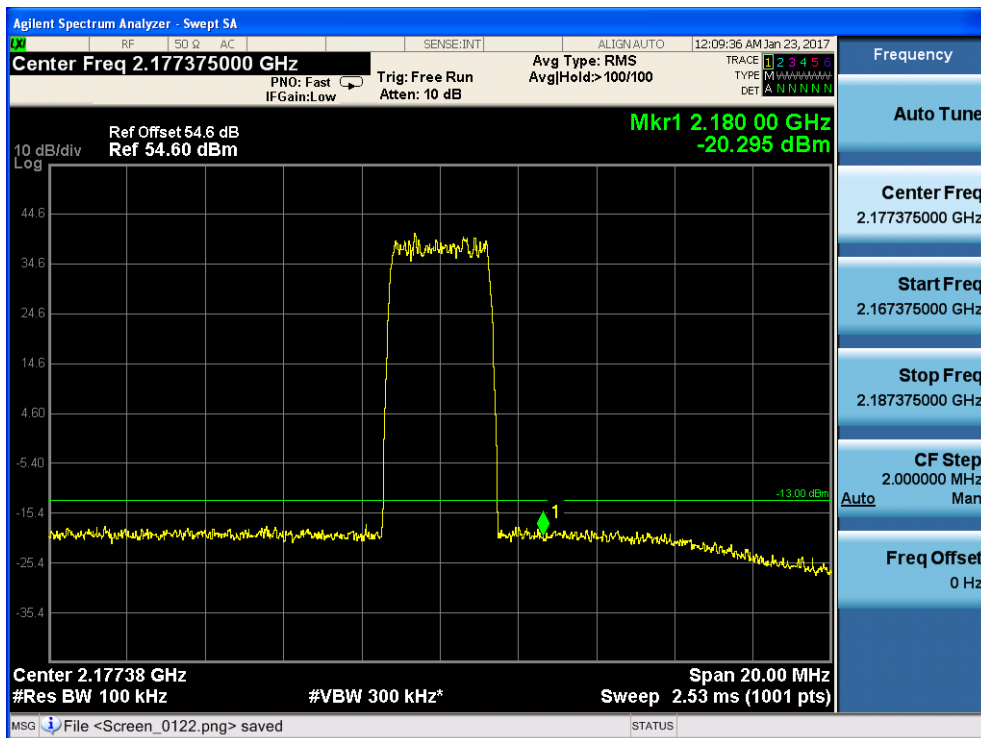

4.2 WDMA Mode:

4.2.1 one signal input — Lower Edge

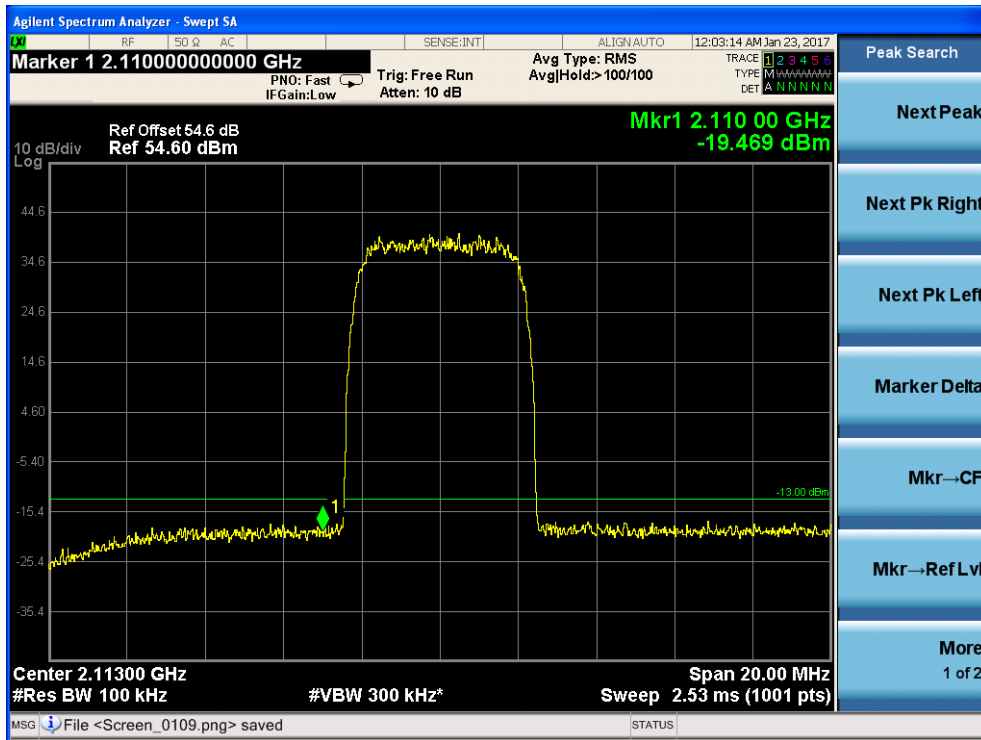

4.2.2 one signal input — Upper Edge

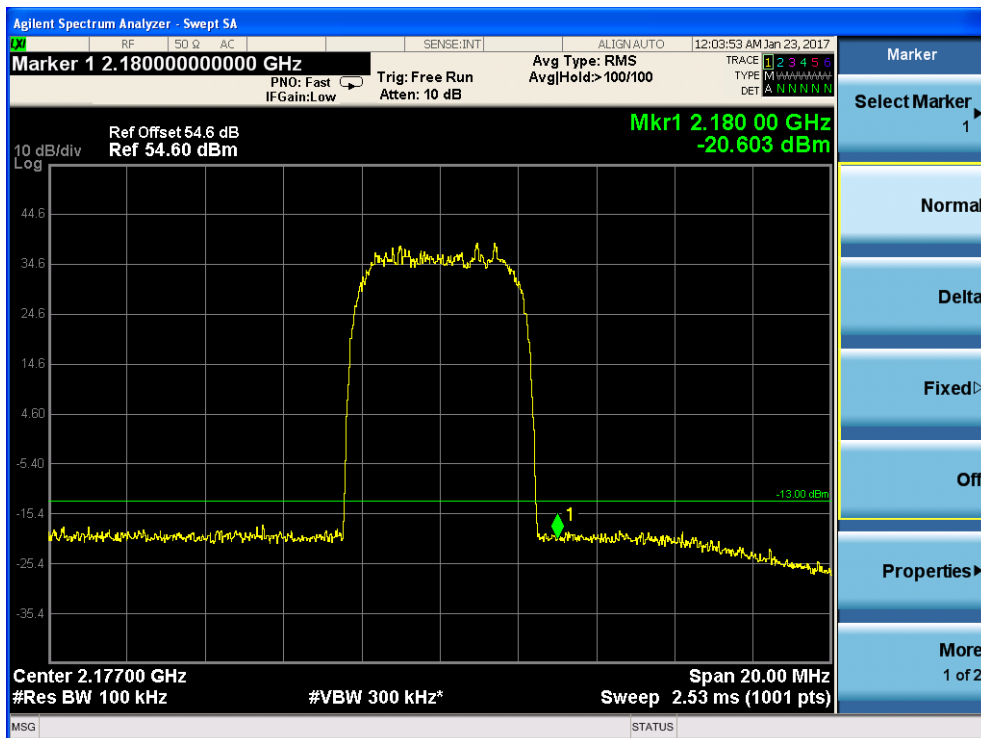

4.2.3 two signal input —Lower Edge

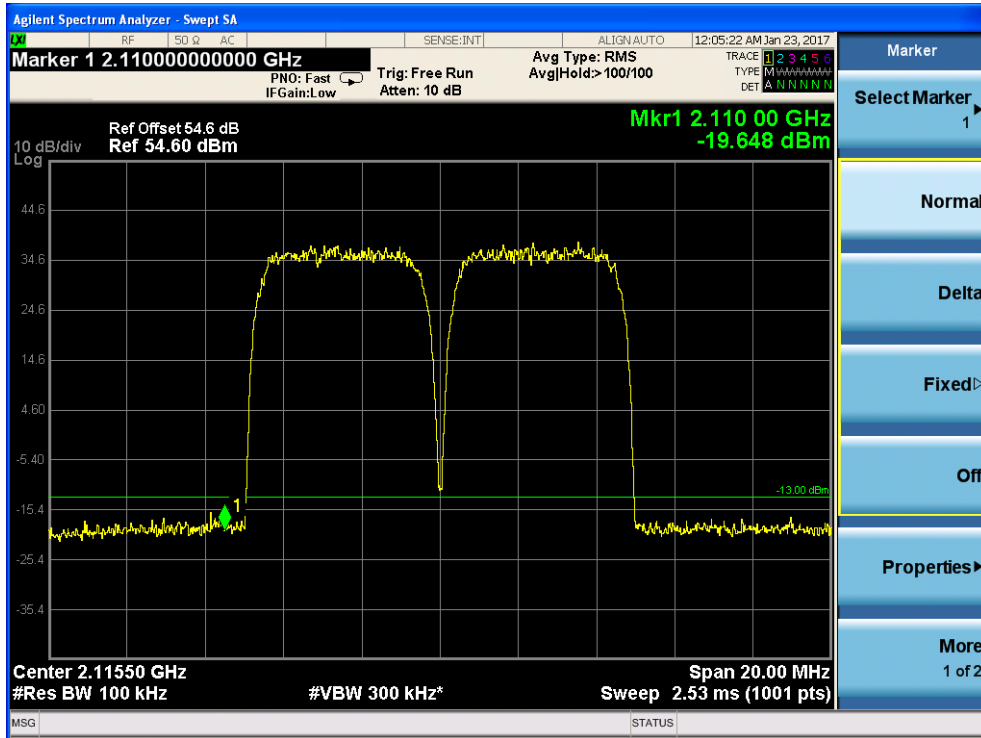

4.2.4 two signal input —Upper Edge

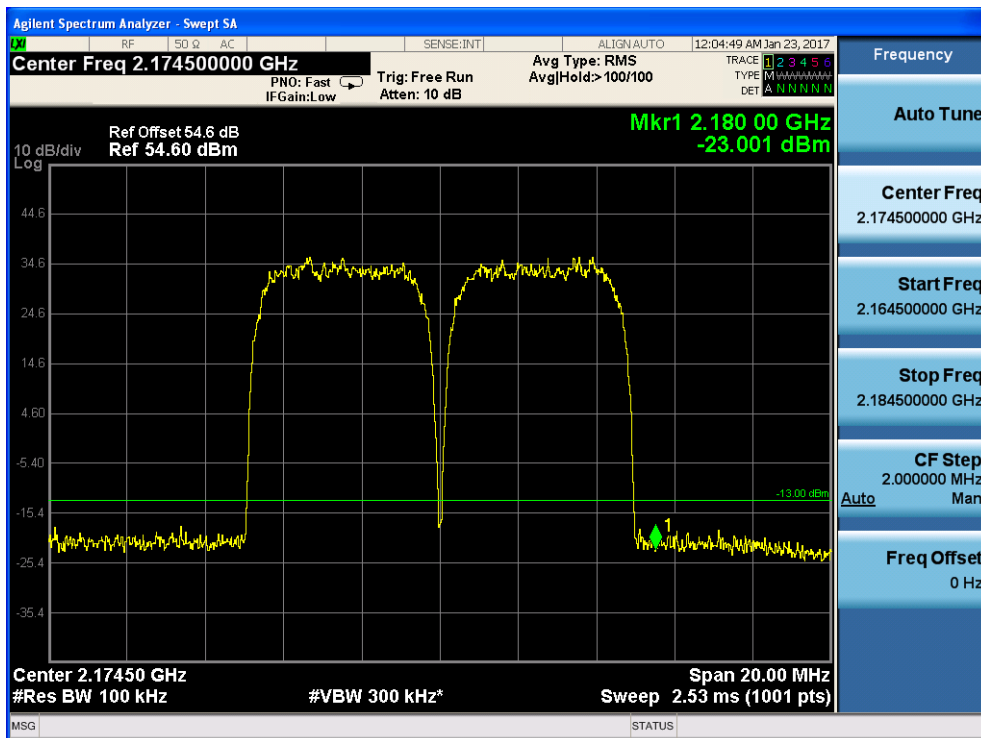

4.3 LTE Mode:

4.3.1 one signal input —Lower Edge

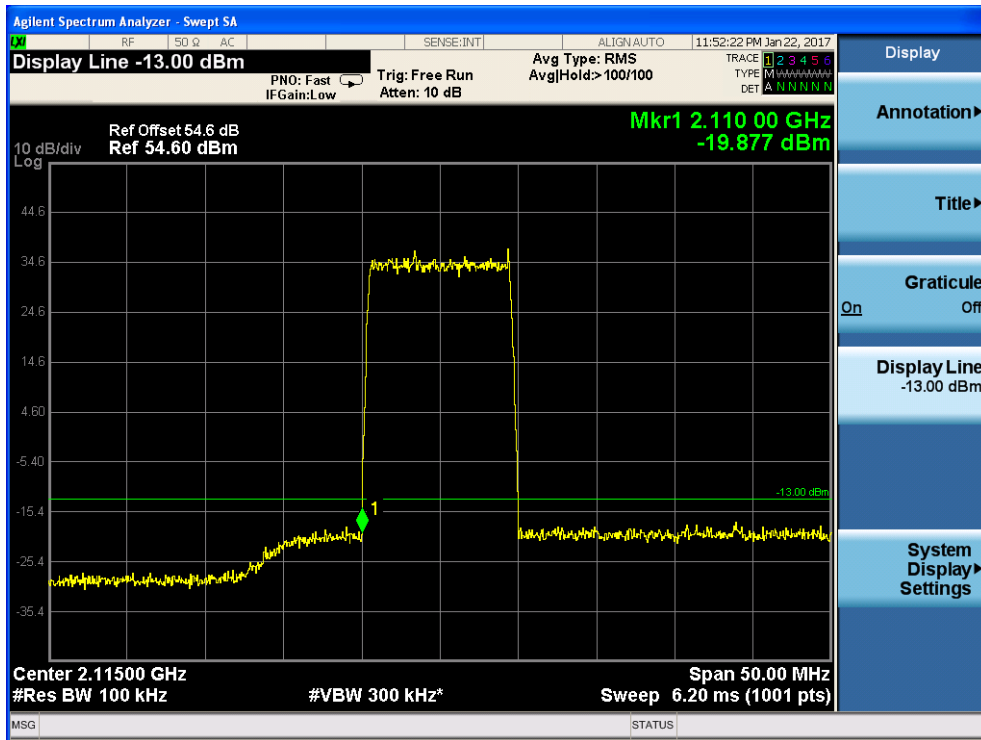

4.3.2 one signal input — Upper Edge

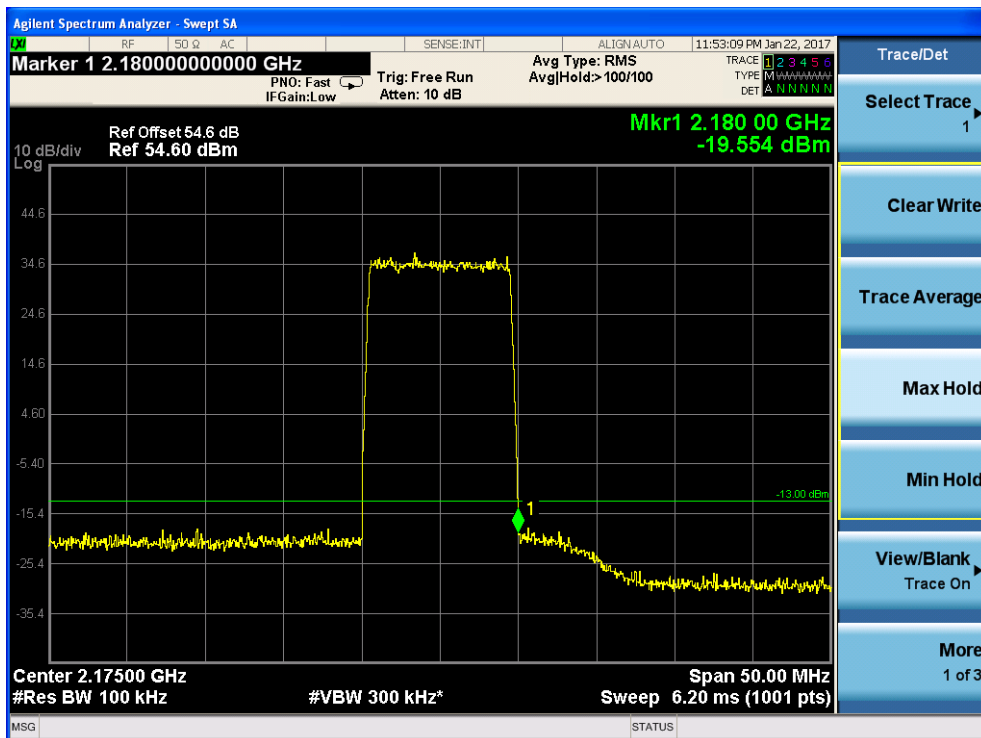



4.3.3 two signal input —Lower Edge

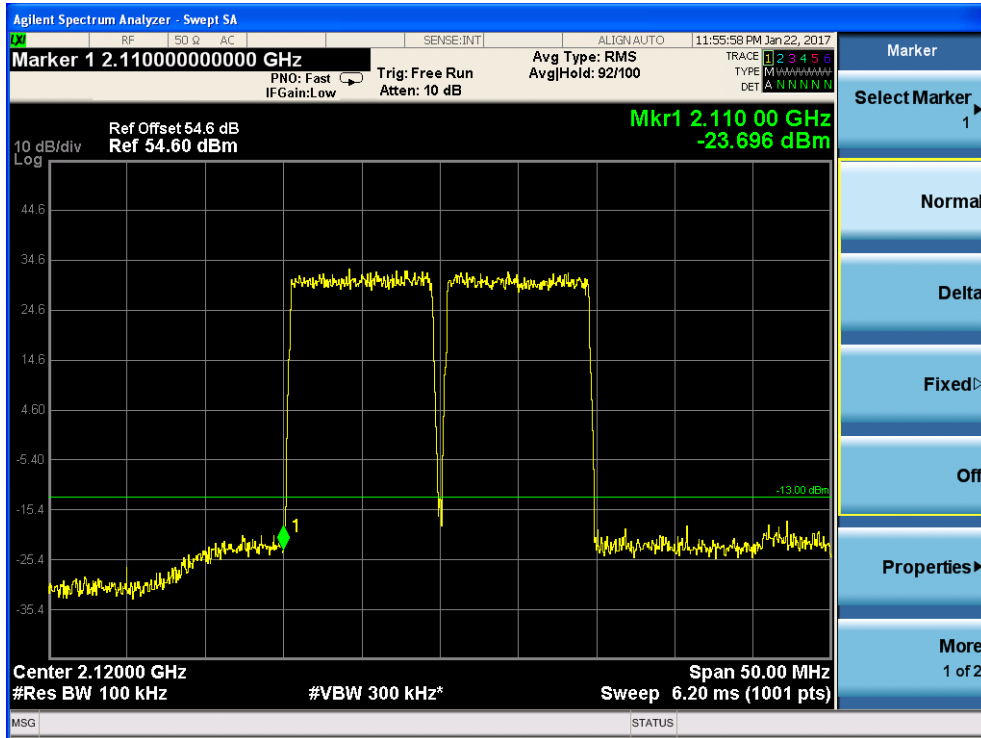

4.3.4 two signal input —Upper Edge

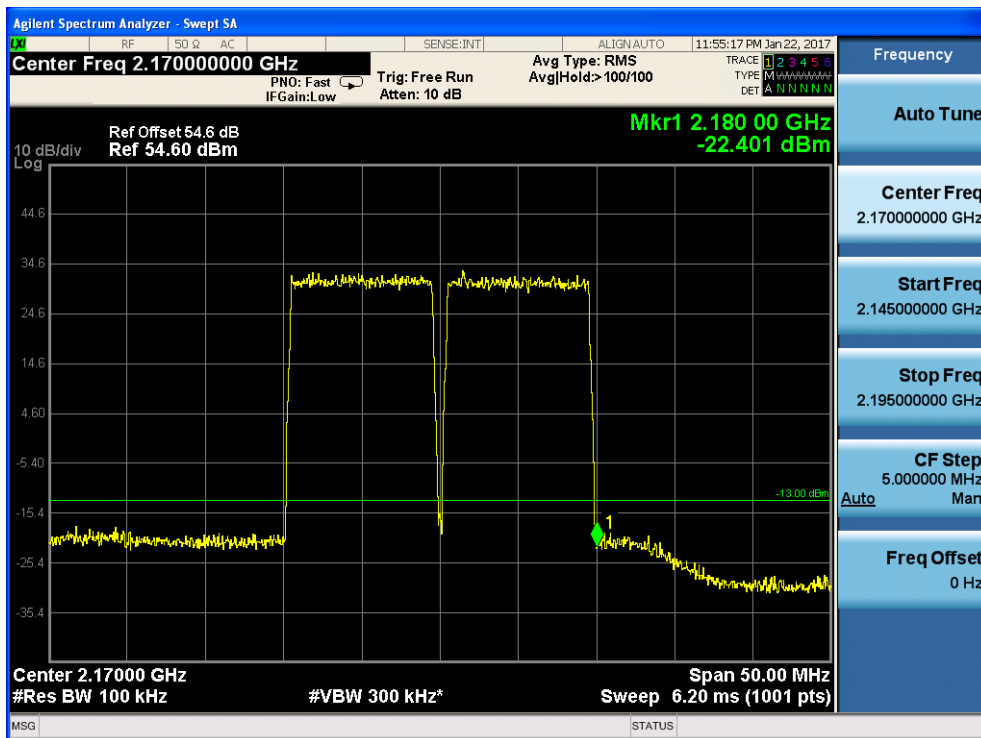

4.4 intermodulation spurious emissions

For CDMA mode:

**4.5.1 Input frequency:**

1) in lower edge test: f1 is the lower edge frequency +1 channel frequency, and f2 is +2 channel frequency

$$f1=2112\text{MHz}, f2=2114\text{MHz}$$

2) in higher edge test: f1 is the higher edge frequency -2 channel frequency, and f2 is -1 channel frequency

$$f1=2151\text{MHz}, f2=2153\text{MHz}$$

base the 3<sup>rd</sup> product frequency  $F1=2f1-f2$  and  $F2=2f2-f1$ , when the f1 and f2 frequency select above,

u) in lower edge test,  $F1=2f1-(f1+\Delta f)=f1-\Delta f$ =lower edge frequency;

v) in higher edge test,  $F2=2f2-(f2-\Delta f)=f2+\Delta f$ =higher edge frequency.

$$F1=2110\text{MHz}, F2=2180\text{MHz}$$

base the 5<sup>rd</sup> product frequency  $F1=3f1-2f2$  and  $F2=3f2-2f1$ , when the f1 and f2 frequency select above,

u) in lower edge test,  $F1=3f1-2(f1+\Delta f)=f1-2\Delta f$ =lower edge frequency;

v) in higher edge test,  $F2=3f2-2(f2-\Delta f)=f2+2\Delta f$ =higher edge frequency.

$$F1=2108\text{MHz}, F2=2182\text{MHz}$$

base the 7<sup>rd</sup> product frequency  $F1=4f1-3f2$  and  $F2=4f2-3f1$ , when the f1 and f2 frequency select above,

u) in lower edge test,  $F1=4f1-3(f1+\Delta f)=f1-3\Delta f$ =lower edge frequency;

v) in higher edge test,  $F2=4f2-3(f2-\Delta f)=f2+3\Delta f$ =higher edge frequency.

$$F1=2106\text{MHz}, F2=2184\text{MHz}$$

**4.5.2 Input power:-20dBm**

measure frequency		product Value (dBm)	Limit (dBm)	Margin (dB)
3 <sup>rd</sup>	Lower:2110MHz	-23.16	-13dBm	-10.16
	Higher:2180MHz	-24.32		-11.32
5 <sup>rd</sup>	Lower:2108MHz	-26.51	-13dBm	-13.51
	Higher:2182MHz	-25.98		-12.98
7 <sup>rd</sup>	Lower:2106MHz	-27.21	-13dBm	-14.21
	Higher:2184MHz	-27.85		-14.85



For WCDMA mode:

**4.5.3 Input frequency:**

1) in lower edge test: f1 is the lower edge frequency +1 channel frequency, and f2 is +2 channel frequency

$f1=2113\text{MHz}, f2=2116\text{MHz}$

2) in higher edge test: f1 is the higher edge frequency -2 channel frequency, and f2 is -1 channel frequency

$f1=2149\text{MHz}, f2=2152\text{MHz}$

base the 3<sup>rd</sup> product frequency  $F1=2f1-f2$  and  $F2=2f2-f1$ , when the f1 and f2 frequency select above,

w) in lower edge test,  $F1=2f1-(f1+\Delta f)=f1-\Delta f$ =lower edge frequency;

x) in higher edge test,  $F2=2f2-(f2-\Delta f)=f2+\Delta f$ =higher edge frequency.

$F1=2110\text{MHz}, F2=2180\text{MHz}$

base the 5<sup>rd</sup> product frequency  $F1=3f1-2f2$  and  $F2=3f2-2f1$ , when the f1 and f2 frequency select above,

w) in lower edge test,  $F1=3f1-2(f1+\Delta f)=f1-2\Delta f$ =lower edge frequency;

x) in higher edge test,  $F2=3f2-2(f2-\Delta f)=f2+2\Delta f$ =higher edge frequency.

$F1=2107\text{MHz}, F2=2183\text{MHz}$

base the 7<sup>rd</sup> product frequency  $F1=4f1-3f2$  and  $F2=4f2-3f1$ , when the f1 and f2 frequency select above,

w) in lower edge test,  $F1=4f1-3(f1+\Delta f)=f1-3\Delta f$ =lower edge frequency;

x) in higher edge test,  $F2=4f2-3(f2-\Delta f)=f2+3\Delta f$ =higher edge frequency.

$F1=2104\text{MHz}, F2=2186\text{MHz}$

**4.5.4 Input power:-20dBm**

measure frequency		product Value (dBm)	Limit (dBm)	Magin (dB)
3 <sup>rd</sup>	Lower:2110MHz	-21.69	-13dBm	-8.69
	Higher:2180MHz	-22.73		-9.73
5 <sup>rd</sup>	Lower:2107MHz	-25.21	-13dBm	-12.21
	Higher:2183MHz	-25.79		-12.79
7 <sup>rd</sup>	Lower:2104MHz	-27.35	-13dBm	-14.35
	Higher:2186MHz	-26.98		-13.98

For LTE mode:

**4.5.5 Input frequency:**

1) in lower edge test: f1 is the lower edge frequency +1 channel frequency, and f2 is +2 channel frequency

$$f1=2115\text{MHz}, f2=2125\text{MHz}$$

2) in higher edge test: f1 is the higher edge frequency -2 channel frequency, and f2 is -1 channel frequency

$$f1=2140\text{MHz}, f2=2150\text{MHz}$$

base the 3<sup>rd</sup> product frequency  $F1=2f1-f2$  and  $F2=2f2-f1$ , when the f1 and f2 frequency select above,

y) in lower edge test,  $F1=2f1-(f1+\Delta f)=f1-\Delta f$ =lower edge frequency;

z) in higher edge test,  $F2=2f2-(f2-\Delta f)=f2+\Delta f$ =higher edge frequency.

$$F1=2110\text{MHz}, F2=2180\text{MHz}$$

base the 5<sup>rd</sup> product frequency  $F1=3f1-2f2$  and  $F2=3f2-2f1$ , when the f1 and f2 frequency select above,

y) in lower edge test,  $F1=3f1-2(f1+\Delta f)=f1-2\Delta f$ =lower edge frequency;

z) in higher edge test,  $F2=3f2-2(f2-\Delta f)=f2+2\Delta f$ =higher edge frequency.

$$F1=2100\text{MHz}, F2=2190\text{MHz}$$

base the 7<sup>rd</sup> product frequency  $F1=4f1-3f2$  and  $F2=4f2-3f1$ , when the f1 and f2 frequency select above,

y) in lower edge test,  $F1=4f1-3(f1+\Delta f)=f1-3\Delta f$ =lower edge frequency;

z) in higher edge test,  $F2=4f2-3(f2-\Delta f)=f2+3\Delta f$ =higher edge frequency.

$$F1=2090\text{MHz}, F2=2200\text{MHz}$$

**4.5.6 Input power:-20dBm**

measure frequency		product Value (dBm)	Limit (dBm)	Magin (dB)
3 <sup>rd</sup>	Lower:2110MHz	-22.73	-13dBm	-9.73
	Higher:2180MHz	-23.58		-10.58
5 <sup>rd</sup>	Lower:2100MHz	-24.97	-13dBm	-11.97
	Higher:2190MHz	-23.89		-10.89
7 <sup>rd</sup>	Lower:2090MHz	-26.83	-13dBm	-13.83
	Higher:2200MHz	-26.72		-13.72

Remark:

No other intermodulation spurious emissioins of above 7<sup>rd</sup> have been found,so only record the test data about the 3<sup>rd</sup>, 5<sup>rd</sup> and 7<sup>rd</sup>



Remark:

For the test in two signal input or intermodulation, test input signal  $f_1$  and  $f_2$  will consider as follows conditions:

- 2) EUT frequency band span and the amount of channels;
- 3)  $f_1$  is the frequency lower,  $f_2$  is the frequency higher,  $\Delta f$  is the channel spacing;
- 4) in lower edge test,  $f_1$  is the lower edge frequency +1 channel frequency, and  $f_2$  is +2 channel frequency;
- 5) in higher edge test,  $f_1$  is the higher edge frequency -2 channel frequency, and  $f_2$  is -1 channel frequency;
- 6) according to the amplifier characteristic, the 3<sup>rd</sup> product will appear when two signals input;
- 7) base the 3<sup>rd</sup> product frequency  $F_1 = 2f_1 - f_2$  and  $F_2 = 2f_2 - f_1$ , when the  $f_1$  and  $f_2$  frequency select above,
  - a) in lower edge test,  $F_1 = 2f_1 - (f_1 + \Delta f) = f_1 - \Delta f =$  lower edge frequency;
  - b) in higher edge test,  $F_2 = 2f_2 - (f_2 - \Delta f) = f_2 + \Delta f =$  higher edge frequency.
- 8) base the 5<sup>rd</sup> product frequency  $F_1 = 3f_1 - 2f_2$  and  $F_2 = 3f_2 - 2f_1$ , when the  $f_1$  and  $f_2$  frequency select above,
  - a) in lower edge test,  $F_1 = 3f_1 - 2(f_1 + \Delta f) = f_1 - 2\Delta f =$  lower edge frequency;
  - b) in higher edge test,  $F_2 = 3f_2 - 2(f_2 - \Delta f) = f_2 + 2\Delta f =$  higher edge frequency.
- 9) base the 7<sup>rd</sup> product frequency  $F_1 = 4f_1 - 3f_2$  and  $F_2 = 4f_2 - 3f_1$ , when the  $f_1$  and  $f_2$  frequency select above,
  - a) in lower edge test,  $F_1 = 4f_1 - 3(f_1 + \Delta f) = f_1 - 3\Delta f =$  lower edge frequency;
  - b) in higher edge test,  $F_2 = 4f_2 - 3(f_2 - \Delta f) = f_2 + 3\Delta f =$  higher edge frequency.



### 7.2.4 Radiated Spurious Emissions

Test Date: 2017-01-22 and 2017-02-08

Test Requirement: FCC part 90.210 & FCC part 22.917(a) & FCC part 24.238(a) & FCC part 27.53(h)

90.210, table "Application Emission Mask"

Frequency Band(MHz)	Mask for equipment with Audio Low pass filter	Mask for equipment without Audio Low pass filter
806-809/851-854	B	H
809-824/854-869 <sup>3</sup>	B	G

(g) Emission Mask G. For transmitters that are not equipped with an audio low-pass filter, the power of an emission must be attenuated below the unmodulated carrier power (P) as follows:

(2) On any frequency removed from the center of the authorized bandwidth by more than 250 percent of the authorized bandwidth: At least  $43 + 10 \log(P)$  dB.

22.917(a) Out of band emissions. The power of any emission outside of the authorized operating frequency ranges must be attenuated below the transmitting power (P) by a factor of at least  $43 + 10 \log(P)$  dB.

24.238(a) Out of band emissions. The power of any emission outside of the authorized operating frequency ranges must be attenuated below the transmitting power (P) by a factor of at least  $43 + 10 \log(P)$  dB.

27.53(h) For operations in the 1710–1755 MHz and 2110–2155 MHz bands, the power of any emission outside a licensee's frequency block shall be attenuated below the transmitter power (P) by at least  $43 + 10 \log(P)$  dB.

Test Method: FCC part 2.1053

ANSI/TIA-603-C-2004

EUT Operation:

Status: Drive the EUT to maximum output power.

Conditions: Normal conditions

Application: Enclosure

Test Configuration:

9 kHz to 30 MHz emissions:

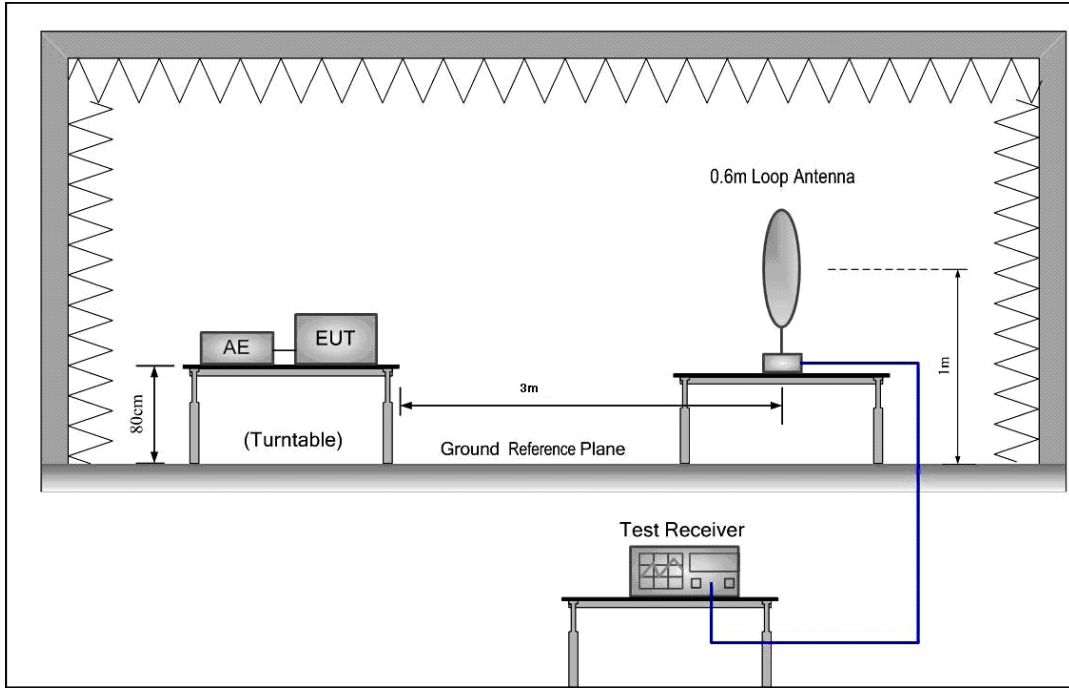

30MHz to 1GHz emissions:

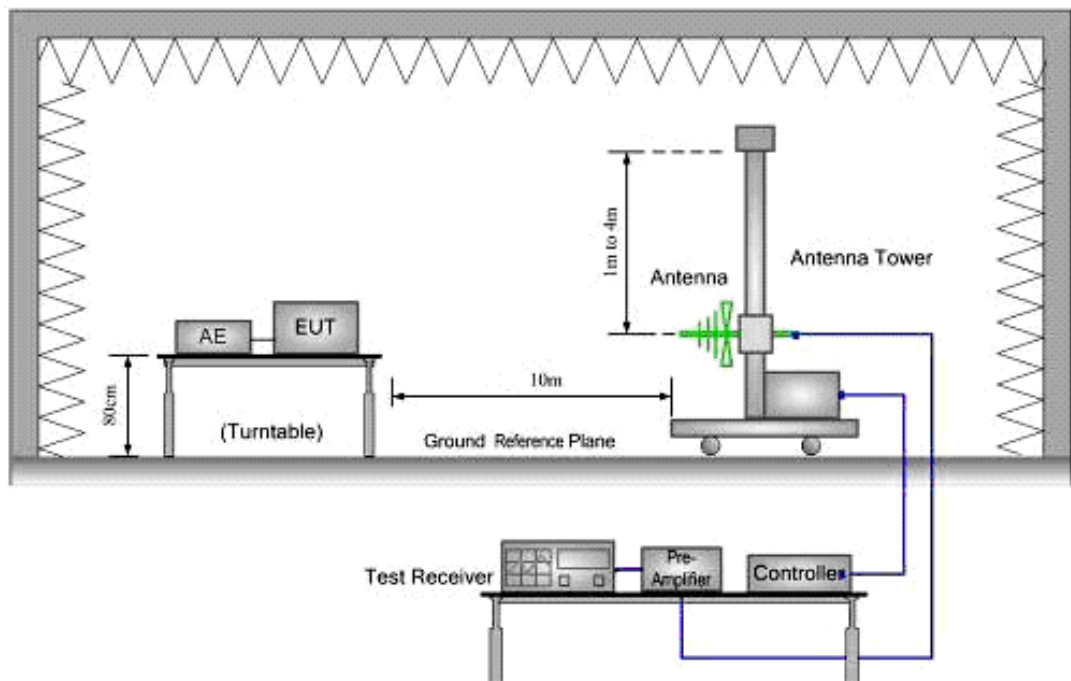

1GHz to 40GHz emissions:

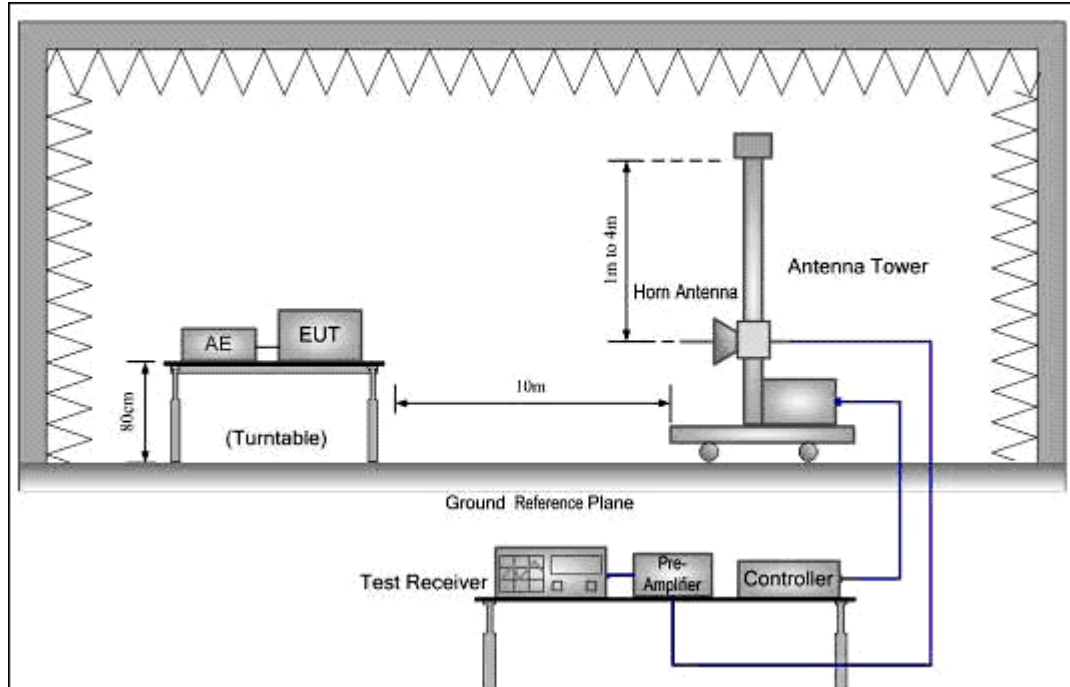

Test Procedure:

1. Test the background noise level with all the test facilities;
2. Keep one transmitting path, all other connectors shall be connected by normal power or RF leads;
3. Select the suitable RF notch filter to avoid the test receiver or spectrum analyzer produce unwanted spurious emissions;
4. Keep the EUT continuously transmitting in max power;
5. Read the radiated emissions of the EUT enclosure.



Radiated Emissions Test Procedure:

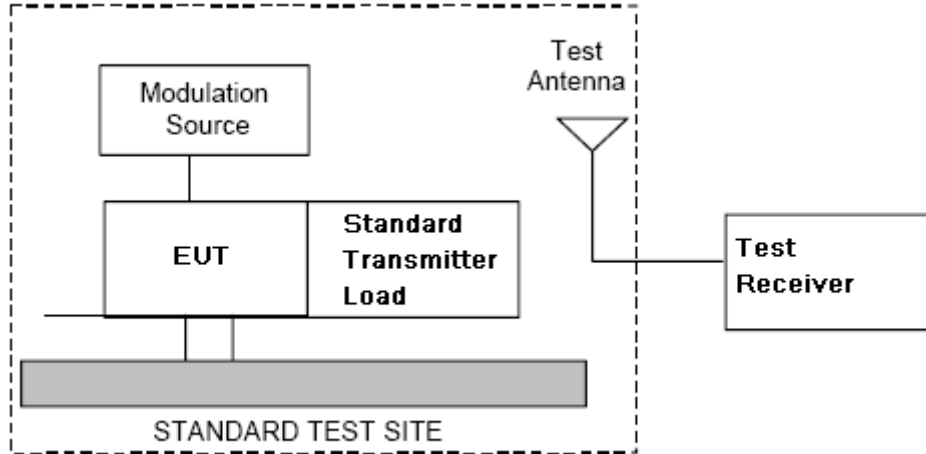

- a) Connect the equipment as illustrated.
- b) Adjust the spectrum analyzer for the following settings:
  - 1) Resolution Bandwidth = 100 kHz for spurious emissions below 1 GHz, and 1 MHz for spurious emissions above 1GHz.
  - 2) Video Bandwidth = 300 kHz for spurious emissions below 1 GHz, and 3 MHz for spurious emissions above 1 GHz.
  - 3) Sweep Speed slow enough to maintain measurement calibration.
  - 4) Detector Mode = Positive Peak.
- c) Place the transmitter to be tested on the turntable in the standard test site, The transmitter is transmitting into a nonradiating load that is placed on the turntable. The RF cable to this load should be of minimum length.
- d) Measurements shall be made from 30MHz to 10 times of fundamental carrier, except for the region close to the carrier equal to  $\pm$  the carrier bandwidth.
- e) Key the transmitter without modulation or normal modulation base the standard.
- f) For each spurious frequency, raise and lower the test antenna from 1 m to 4 m to obtain a maximum reading on the spectrum analyzer with the test antenna at horizontal polarity. Then the turntable should be rotated 360° to determine the maximum reading. Repeat this procedure to obtain the highest possible reading. Record this maximum reading.
- g) Repeat step f) for each spurious frequency with the test antenna polarized vertically.

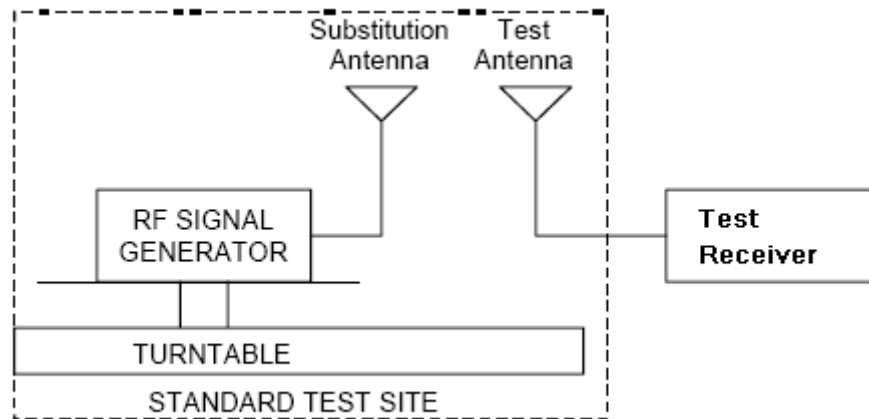

- h) Reconnect the equipment as illustrated.
- i) Keep the spectrum analyzer adjusted as in step b).
- j) Remove the transmitter and replace it with a substitution antenna (the antenna should be half-wavelength for each frequency involved). The center of the substitution antenna should be approximately at the same location as the center of the transmitter. At the lower frequencies, where the substitution antenna is very long, this will be impossible to achieve when the antenna is polarized vertically. In such case the lower end of the antenna should be 0.3 m above the ground.
- k) Feed the substitution antenna at the transmitter end with a signal generator connected to the antenna by means of a nonradiating cable. With the antennas at both ends horizontally polarized, and with the signal generator tuned to a particular spurious frequency, raise and lower the test antenna to obtain a maximum reading at the spectrum analyzer. Adjust the level of the signal generator output until the previously recorded maximum reading for this set of conditions is obtained. This should be done carefully repeating the adjustment of the test antenna and generator output.
- l) Repeat step k) with both antennas vertically polarized for each spurious frequency.
- m) Calculate power in dBm into a reference ideal half-wave dipole antenna by reducing the readings obtained in steps k) and l) by the power loss in the cable between the generator and the antenna, and further corrected for the gain of the substitution antenna used relative to an ideal half-wave dipole

antenna by the following formula:

$$P_d(\text{dBm}) = P_g(\text{dBm}) - \text{cable loss (dB)} + \text{antenna gain (dB)}$$

where:

$P_d$  is the dipole equivalent power and

$P_g$  is the generator output power into the substitution antenna.

NOTE: It is permissible to use other antennas provided they can be referenced to a dipole.

NOTE: Effective radiated power (e.r.p) refers to the radiation of a half wave tuned dipole instead of an isotropic antenna. There is a constant difference of 2.15 dB between e.i.r.p. and e.r.p.

$$\text{e.r.p (dBm)} = \text{e.i.r.p. (dBm)} - 2.15$$

**7.2.4.1 Measurement Record: (need to change data)**

No emissions were detected within 20dB below the limit for the Downlink direction.

**Test Result:**

**9KHz~1000 MHz Field Strength of Unwanted Emissions. Quasi-Peak Measurement**

9KHz~1000 MHz Field Strength of Unwanted Emissions. Quasi-Peak Measurement

The measurements with Loop and Log antennas were greater than 20dB below the limit, so the test data were only recorded one worst mode test graph in the test report.

Test at Frequency (1962MHz) in transmitting status

30 MHz~1 GHz Spurious Emissions .Quasi-Peak Measurement

**Vertical:**

Peak scan

Level (dB $\mu$ V/m)

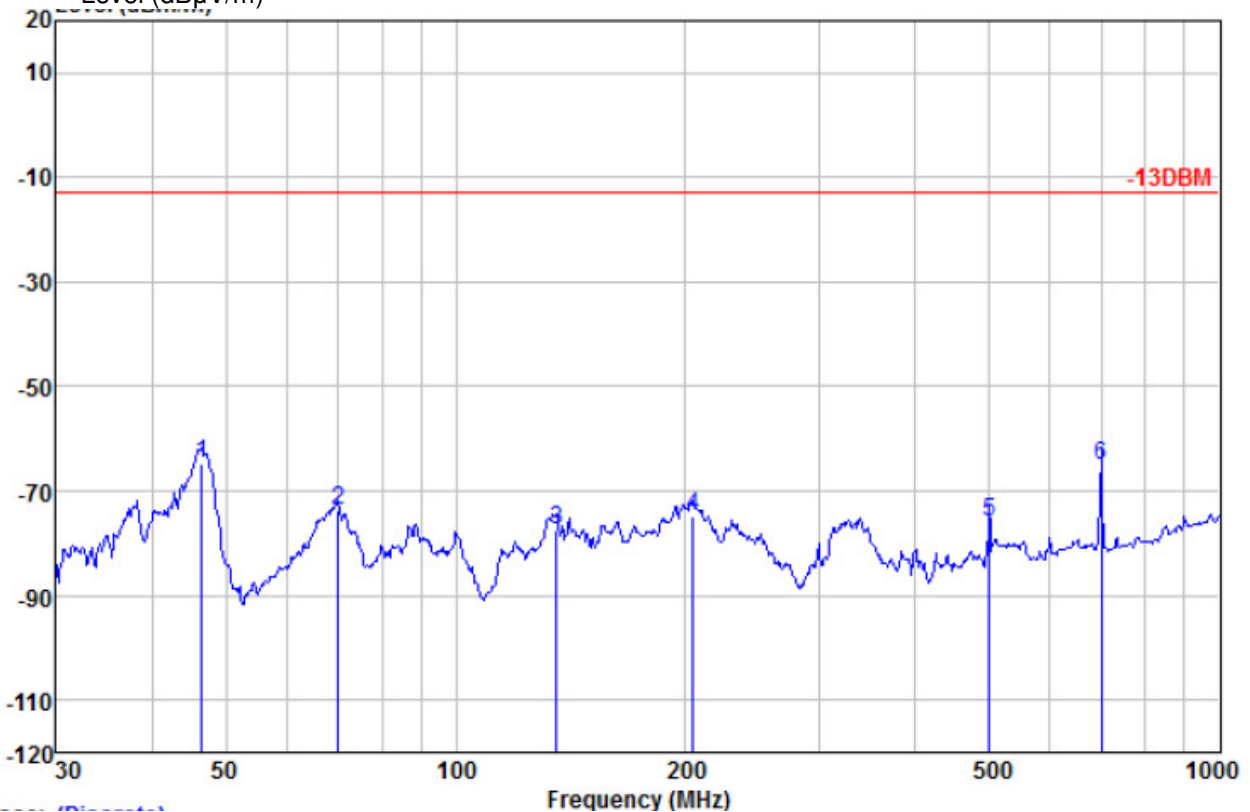

Quasi-peak measurement



# SGS-CSTC Standards Technical Services Co., Ltd.

Report No.: GZEM170100049501

Page: 100 of 157

	Freq	ReadAntenna Level Factor	Cable Loss	Preamp Factor	Level	Limit Line	Over Limit	Remark
	MHz	dBm	dB/m	dB	dBm/m	dBm/m	dB	
1	46.666	-57.26	14.32	1.23	27.00	-68.71	-12.99	-55.72 QP
2	133.151	-64.13	12.51	2.17	26.86	-76.31	-12.99	-63.32 QP
3	166.068	-61.95	13.44	2.41	26.75	-72.85	-12.99	-59.86 QP
4	215.268	-61.81	11.20	2.80	26.55	-74.36	-12.99	-61.37 QP
5	499.425	-62.07	18.10	4.40	27.80	-67.37	-12.99	-54.38 QP
6	699.305	-66.23	21.30	5.20	28.00	-67.73	-12.99	-54.74 QP



**Horizontal:**

Peak scan

Level (dBµV/m)

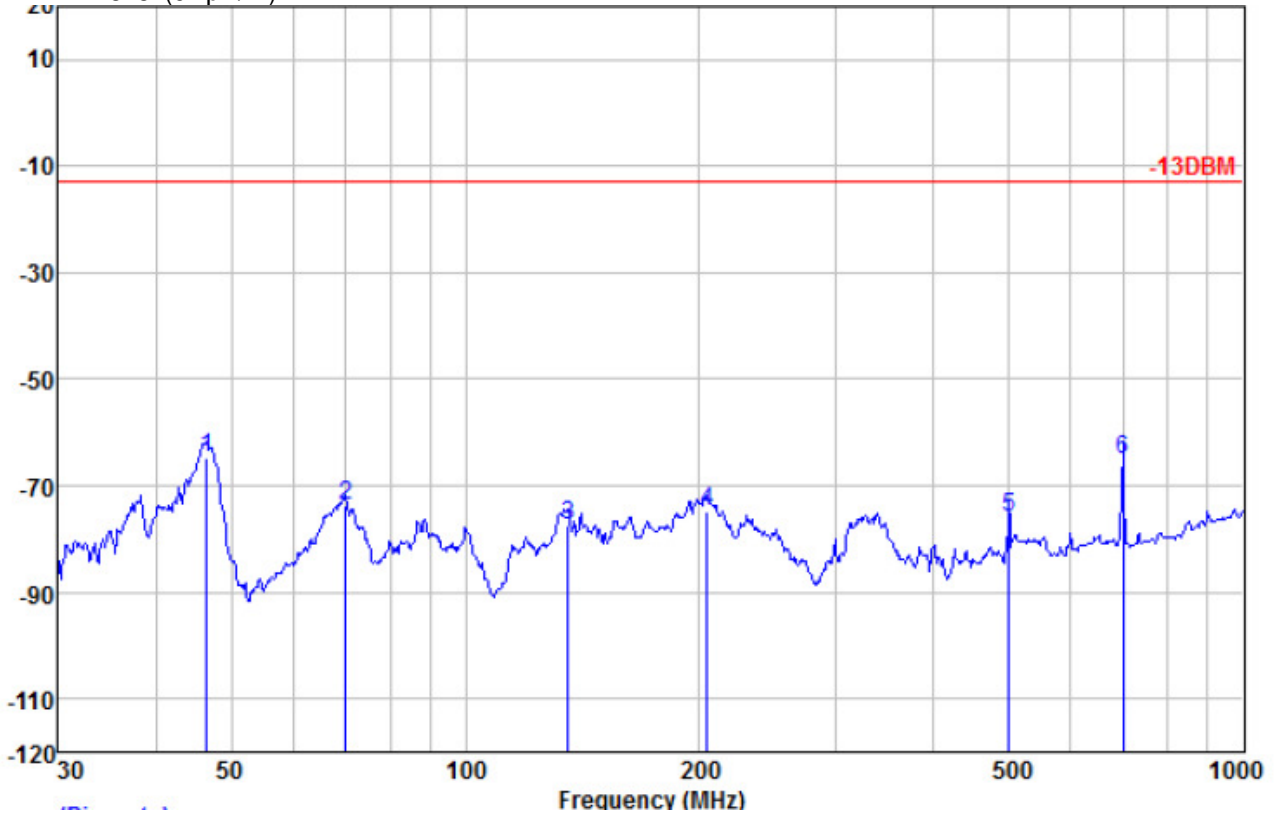

Quasi-peak

measurement

	Read Freq	Antenna Level	Antenna Factor	Cable Loss	Preamplifier Factor	Level	Limit Line	Over Limit	Remark
	MHz	dBm	dB/m	dB	dB	dBm/m	dBm/m	dB	
1	46.503	-53.19	14.31	1.23	27.00	-64.65	-12.99	-51.66	QP
2	70.090	-61.07	12.70	1.50	27.00	-73.87	-12.99	-60.88	QP
3	135.506	-65.41	12.72	2.20	26.84	-77.33	-12.99	-64.34	QP
4	204.238	-62.31	11.20	2.72	26.59	-74.98	-12.99	-61.99	QP
5	499.425	-70.53	18.10	4.40	27.80	-75.83	-12.99	-62.84	QP
6	699.305	-63.58	21.30	5.20	28.00	-65.08	-12.99	-52.09	QP



**Above 1GHz Field Strength of Unwanted Emissions. Quasi-Peak Measurement**

Peak Measurement:

Frequency (MHz)	Antenna factors (dB/m)	Cable loss (dB)	Preamp factor (dB)	Reading Level (dBm)	Emission Level (dBm/m)	Limit (dBm/m)	Over limit (dB)	Antenna polarization
1487.509	24.99	5.48	38.93	-53.96	-62.42	-13	-49.42	Vertical
2406.584	26.46	6.92	39.11	-56.08	-61.81	-13	-48.81	V
2980.327	27.88	7.7	39.4	-43.61	-47.43	-13	-34.43	V
1263.883	24.71	4.94	38.87	-43.2	-52.42	-13	-39.42	Horizontal
2558.193	26.7	7.16	39.16	-45.9	-51.2	-13	-38.20	H
2980.327	27.88	7.7	39.4	-46.34	-50.16	-13	-37.16	H

**Remark:**

The cabinet radiation was measured with the equipment transmitting a CW signal into a non-radiating 50 Ohm load at maximum output power on a signal frequency .

Measured were performed in the lowest, middle and highest frequency for the Downlink of products which included AC and DC Unit.

The spectrum was searched from 9KHz to 26GHz (10th Harmonic) for downlink;

### 7.2.5 Occupied Bandwidth

Test Date: 2017-01-22 and 2017-02-08

Test Requirement: KDB935210 D02;2-11-04/EAB/RF

Test Method: FCC part 2.1049, 2-11-04/EAB/RF

The spectral shape of the output should look similar to input for all modulations.

EUT Operation:

Status: Drive the EUT to maximum output power. .

Conditions: Normal conditions

Application: Cellular Band RF output ports

Test Configuration:

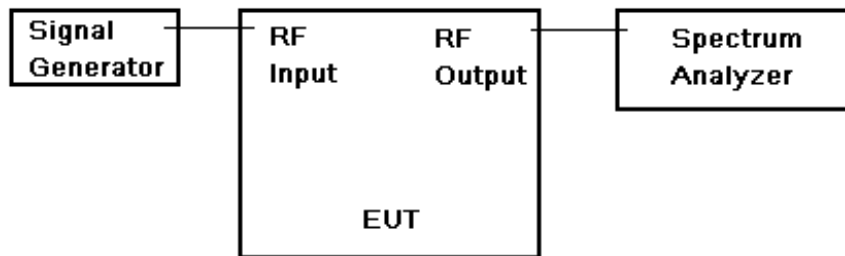

Fig.2. Conducted Spurious Emissions test configuration

Test Procedure:

- a) Set the spectrum analyzer RBW 300 Hz or  $>1\%$  &  $<2\%$  emission bandwidth of carrier.
- b) Capture the trace of input signal;
- c) Connect the equipment as illustrated;
- d) Capture the trace of output signal;

7.2.5.1 Measurement Record:

1. Downlink: 728MHz to 757MHz(LTE mode)

1.1 lowest frequency – Input

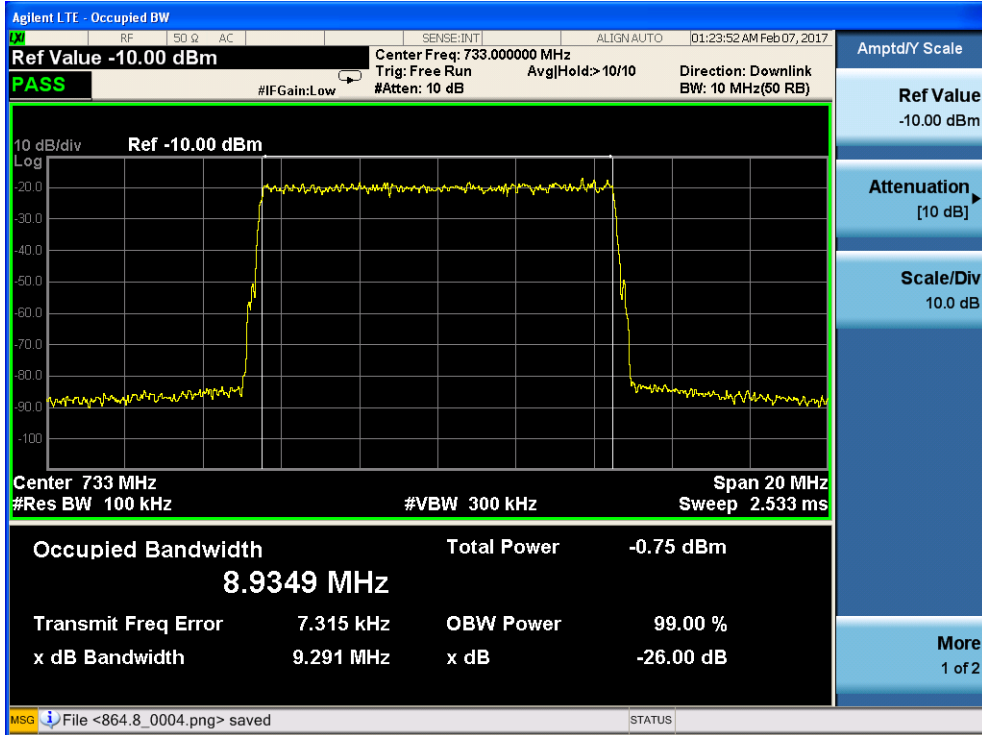

1.2 lowest frequency—Output

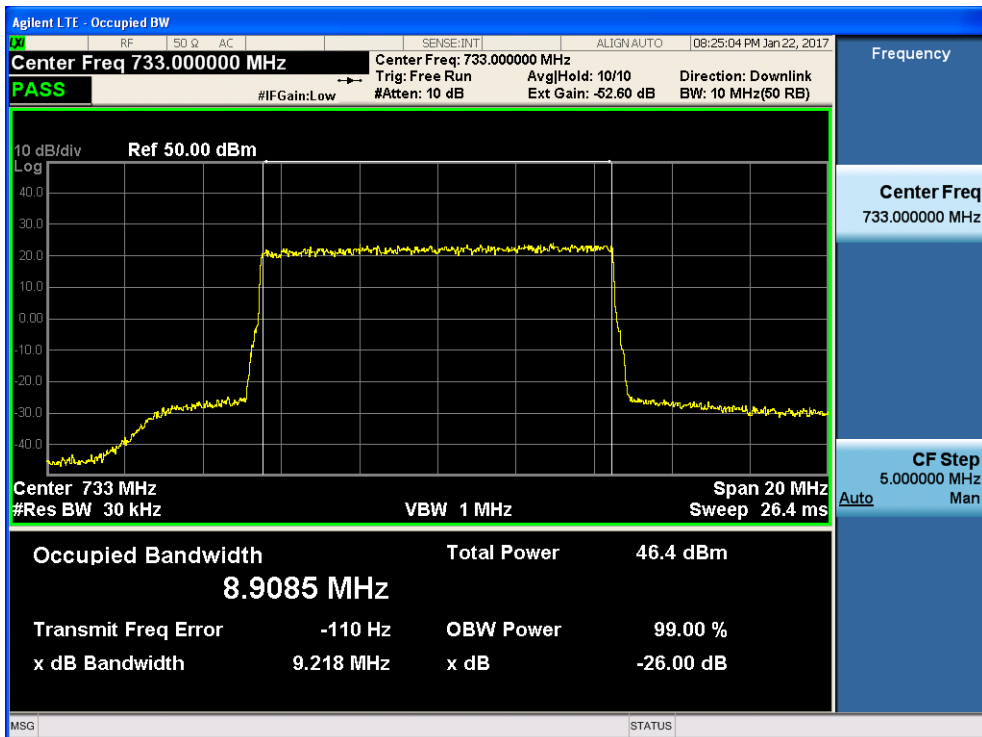



1.3 middle frequency—Input

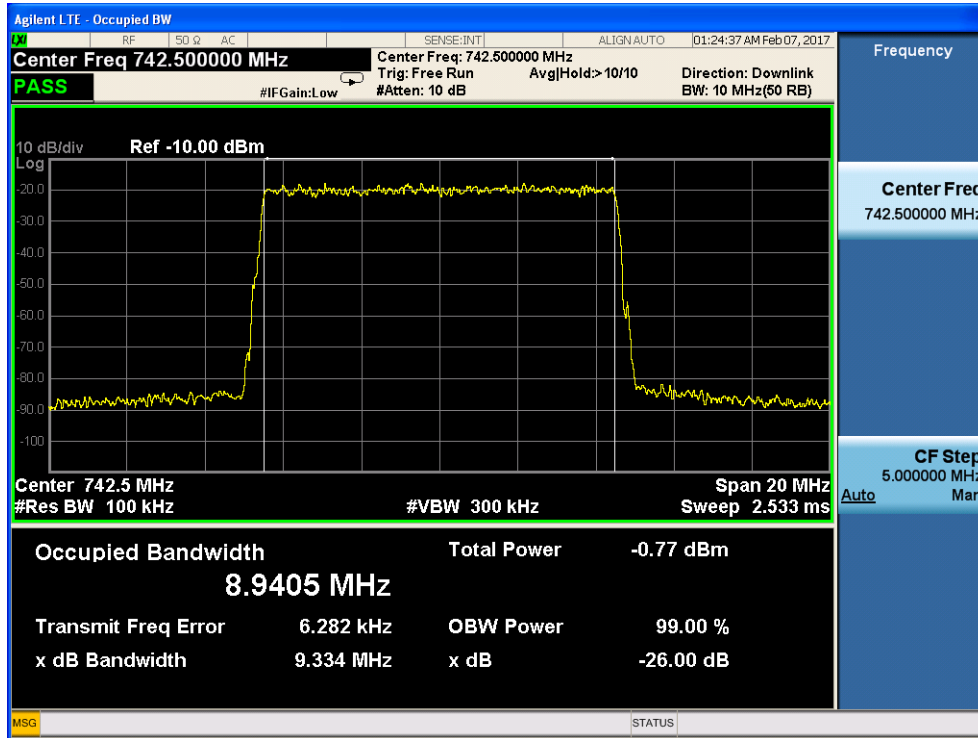

1.4 middle frequency—Output

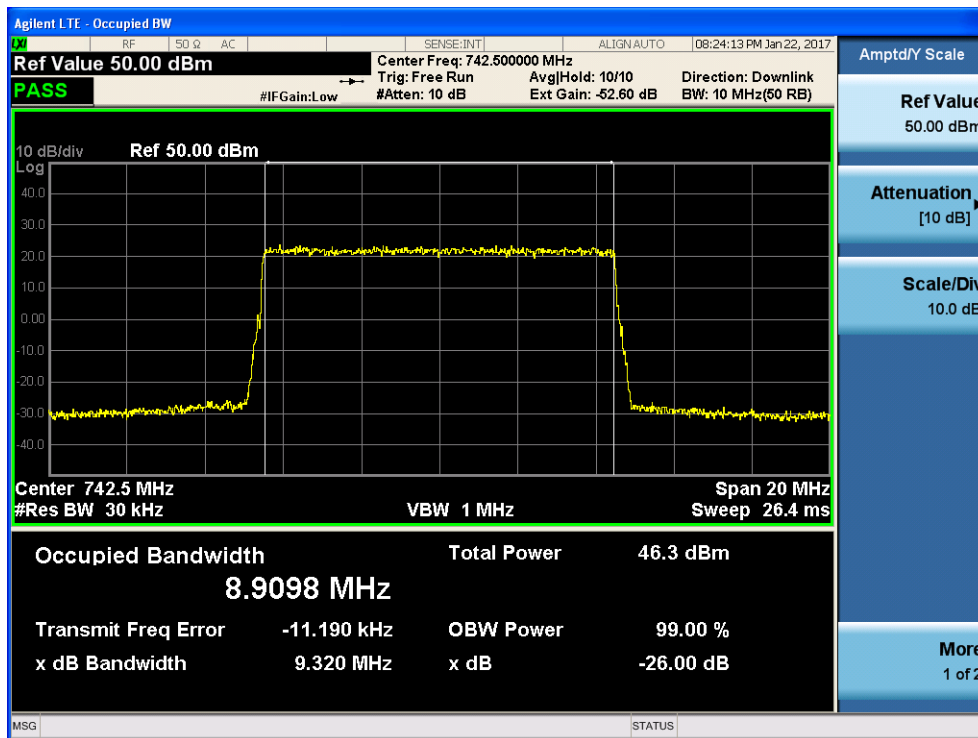

1.5 highest frequency—Input

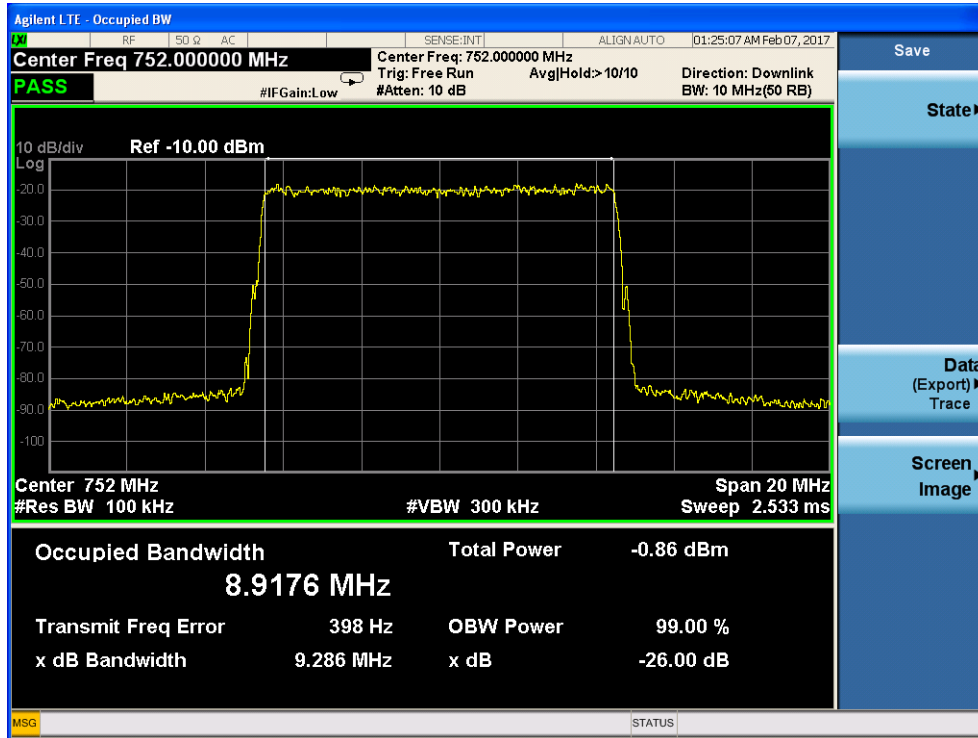

1.6 highest frequency—Output

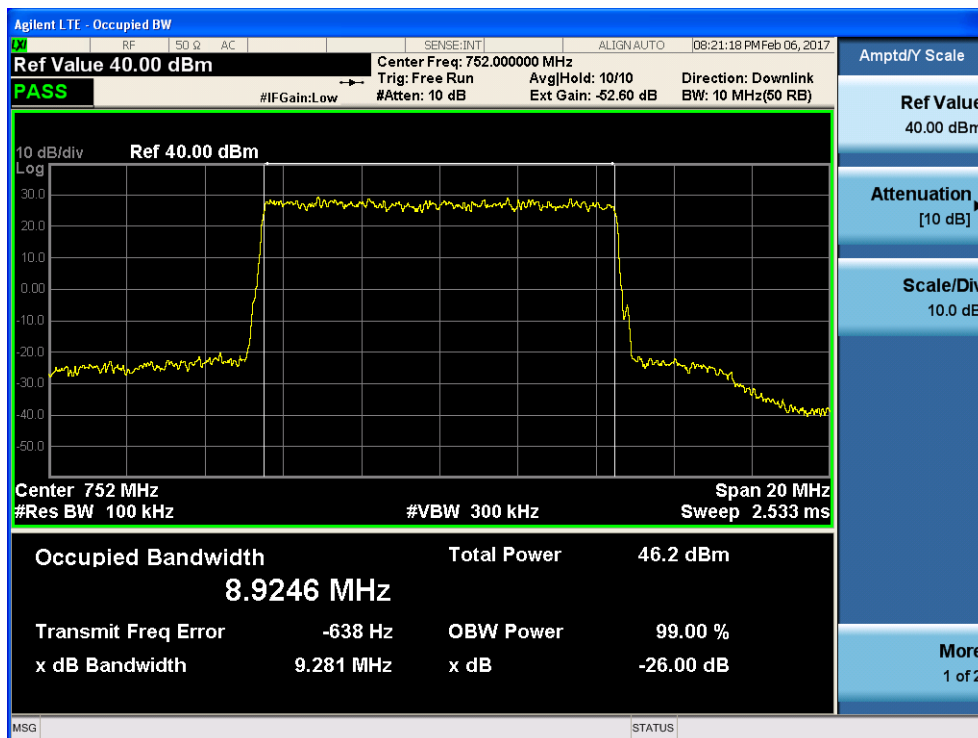

7.2.5.2 Measurement Record:

1. Downlink: 862MHz to 869MHz(CDMA,WCDMA,LTE)

1.1 CDMA Mode:

1.1.1 lowest frequency— Input

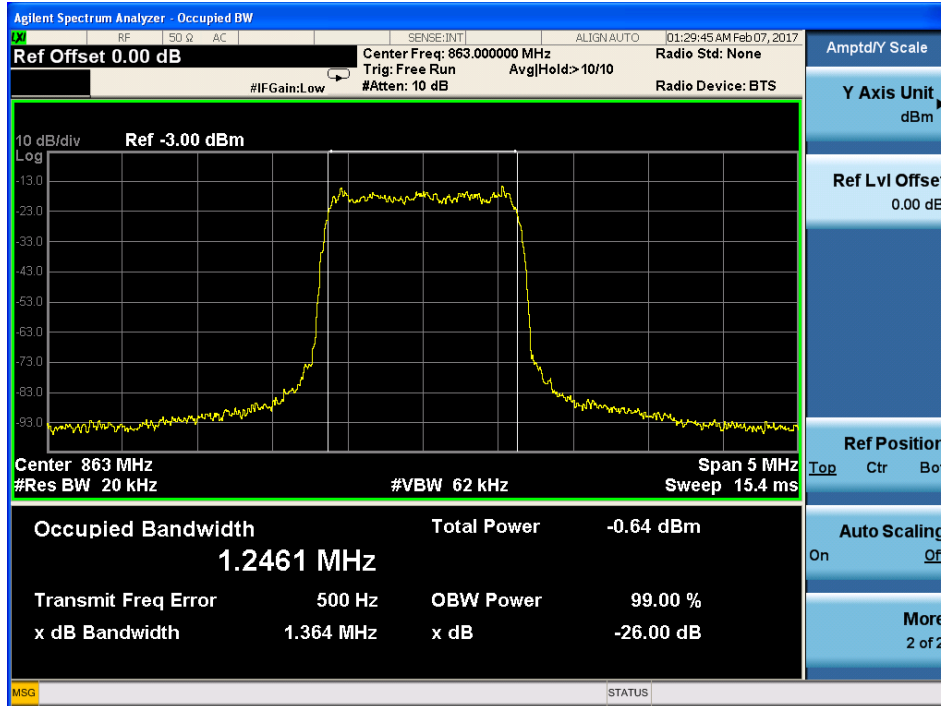

1.1.2 lowest frequency—Output

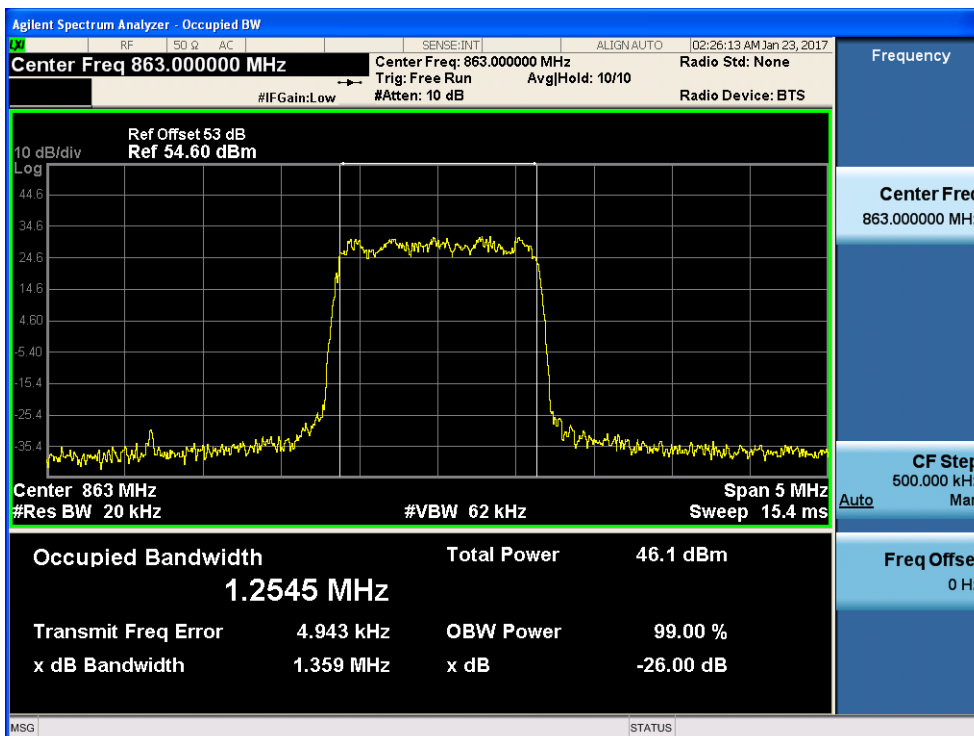

1.1.3 middle frequency—Input

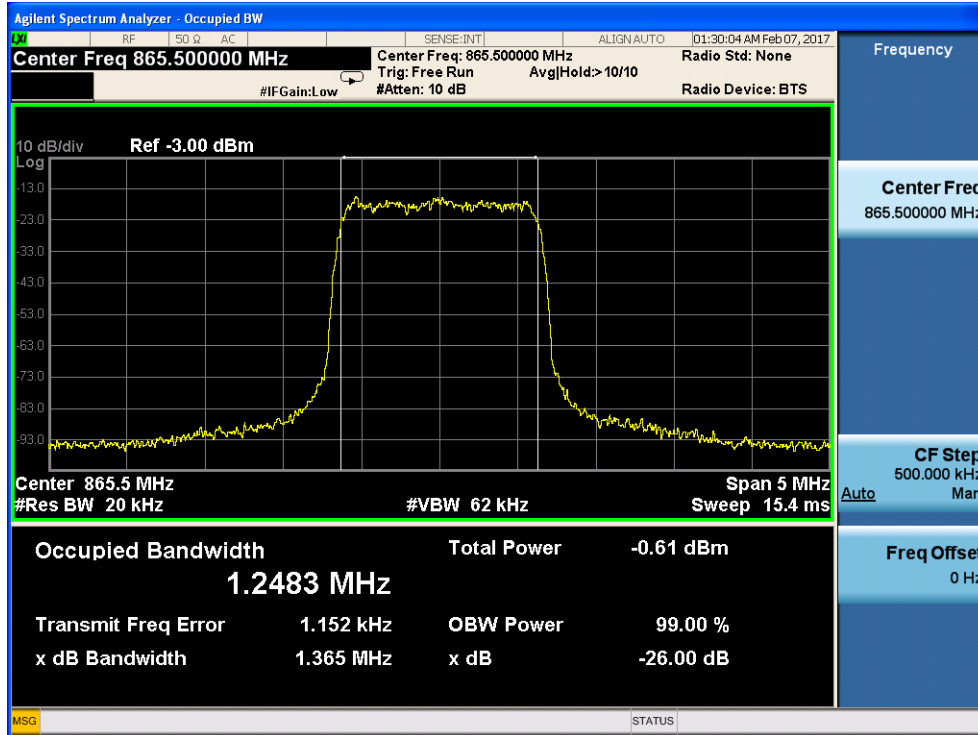

1.1.4 middle frequency—Output

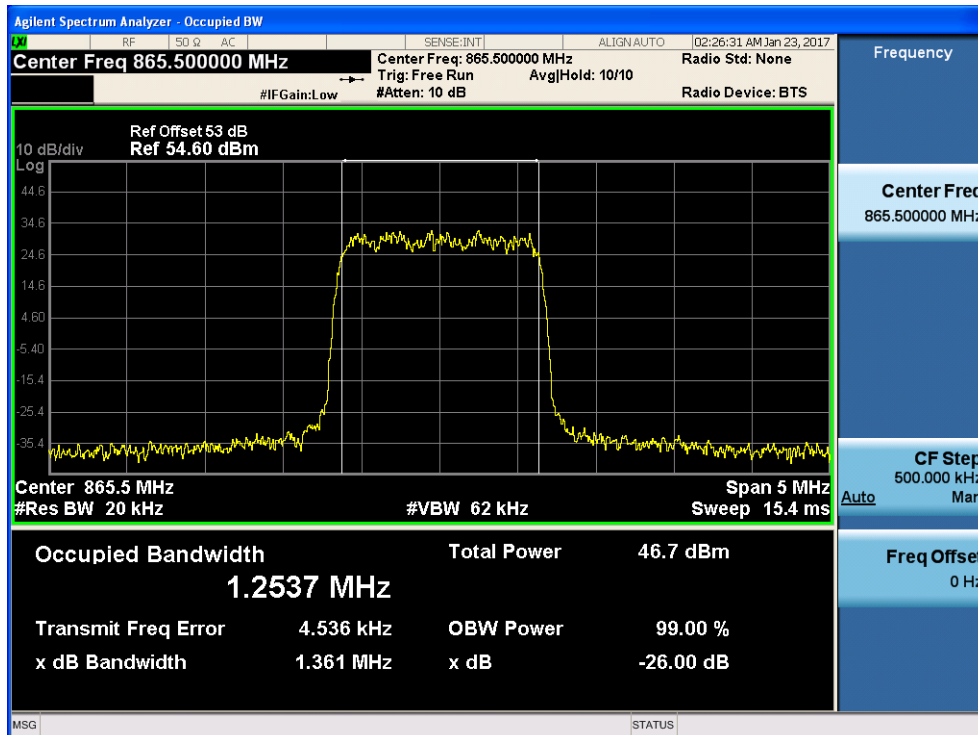



1.1.5 highest frequency—Input

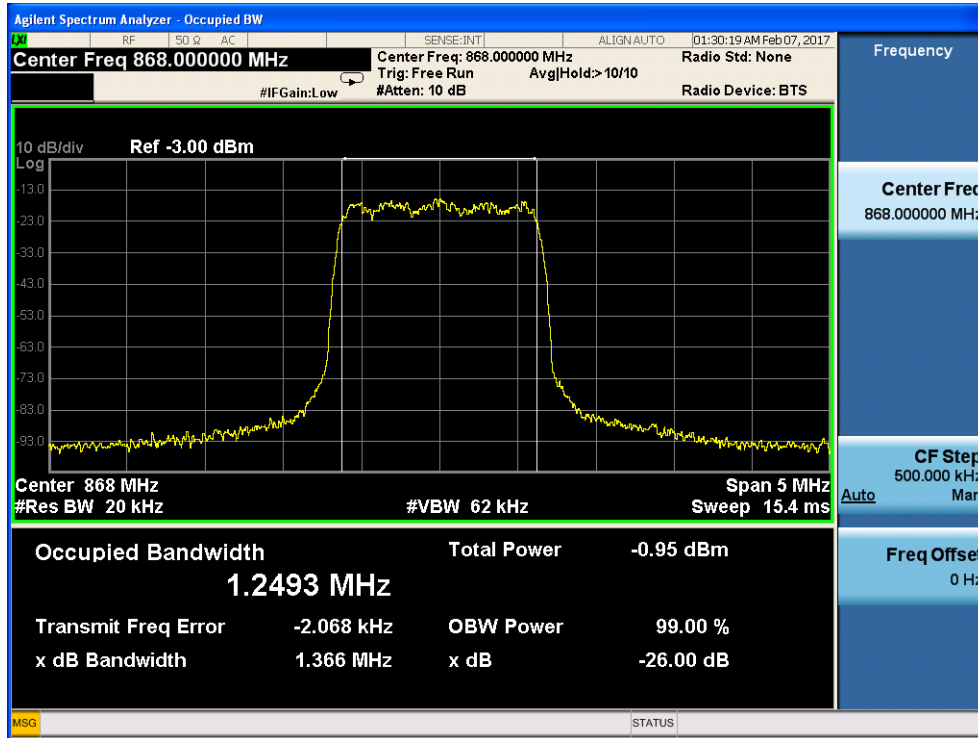

1.1.6 highest frequency—Output

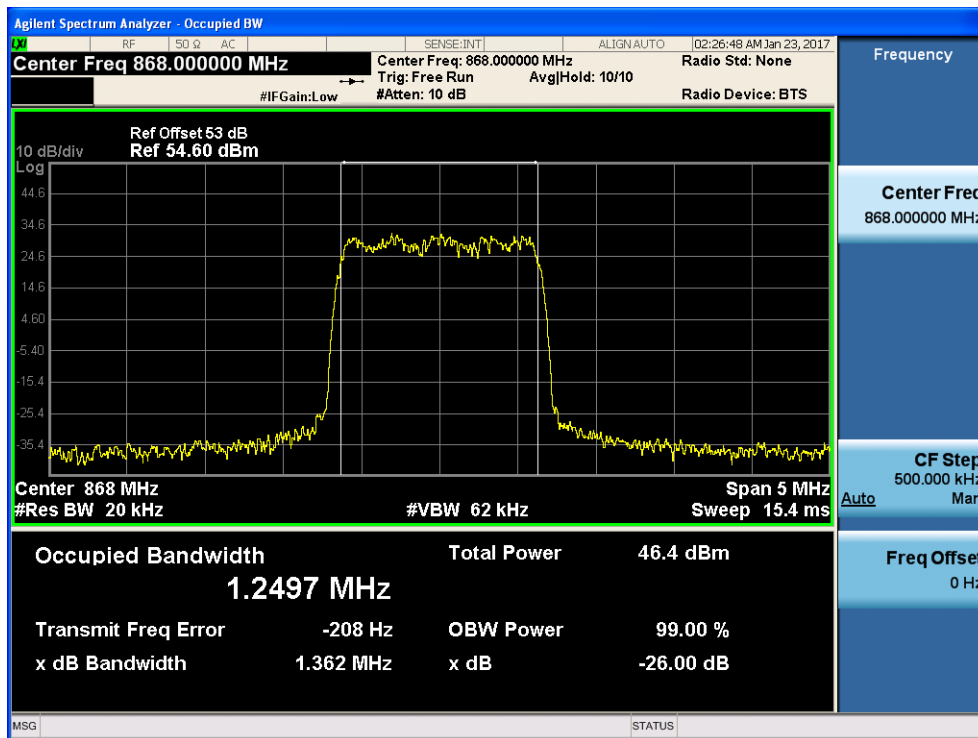

1.2 WCDMA Mode:

1.2.1 Lowest frequency—Input

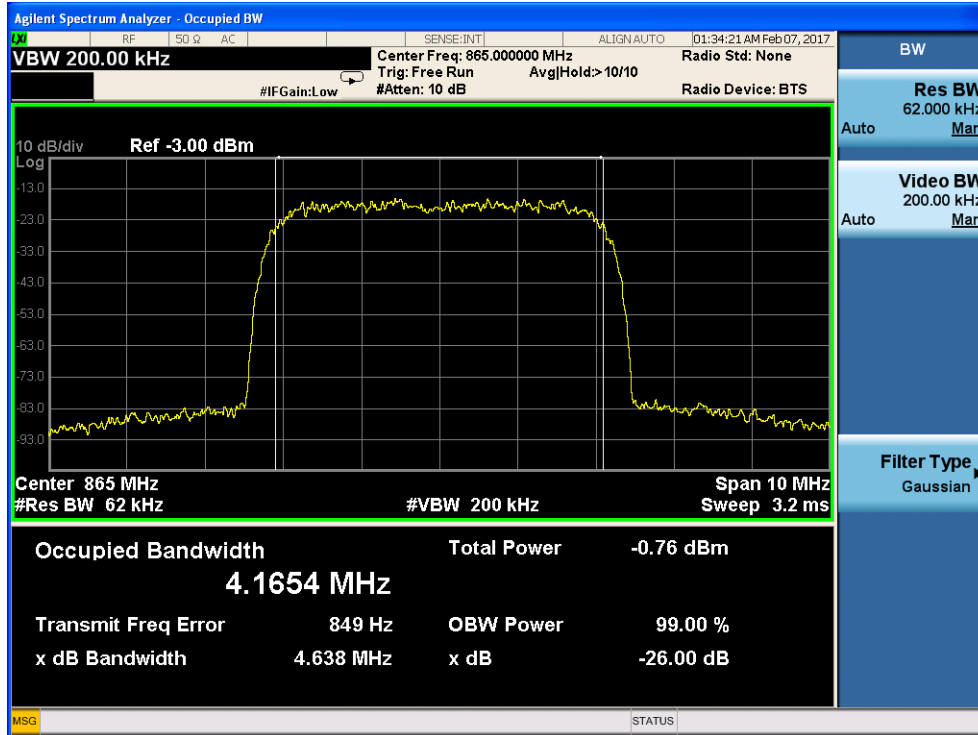

1.2.2 Lowest frequency—Output

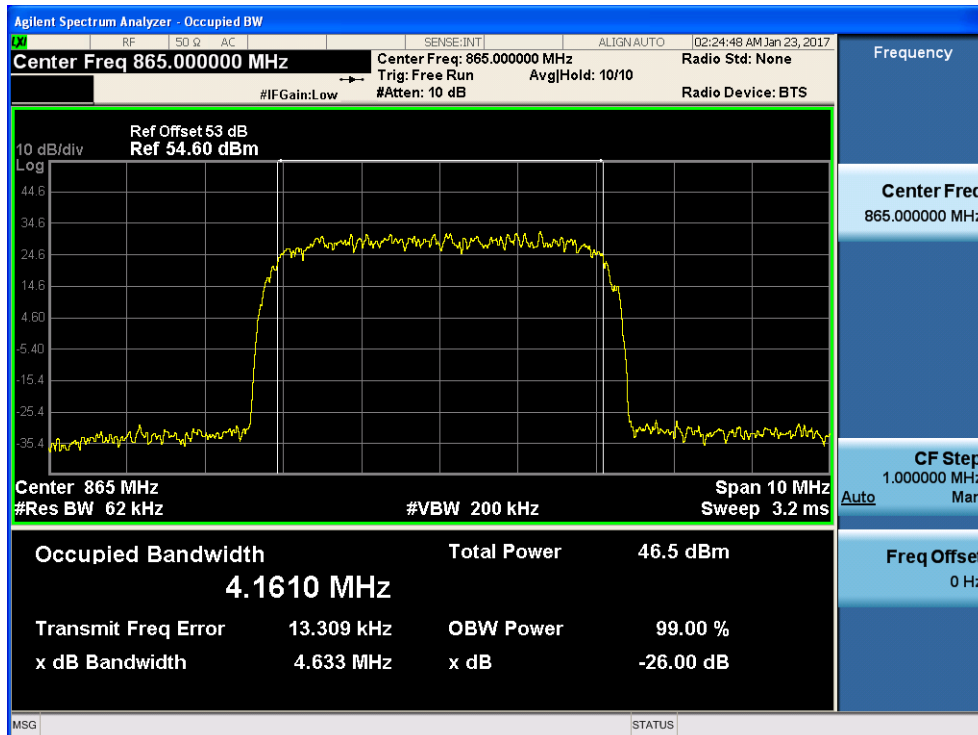

1.2.3 middle frequency—Input

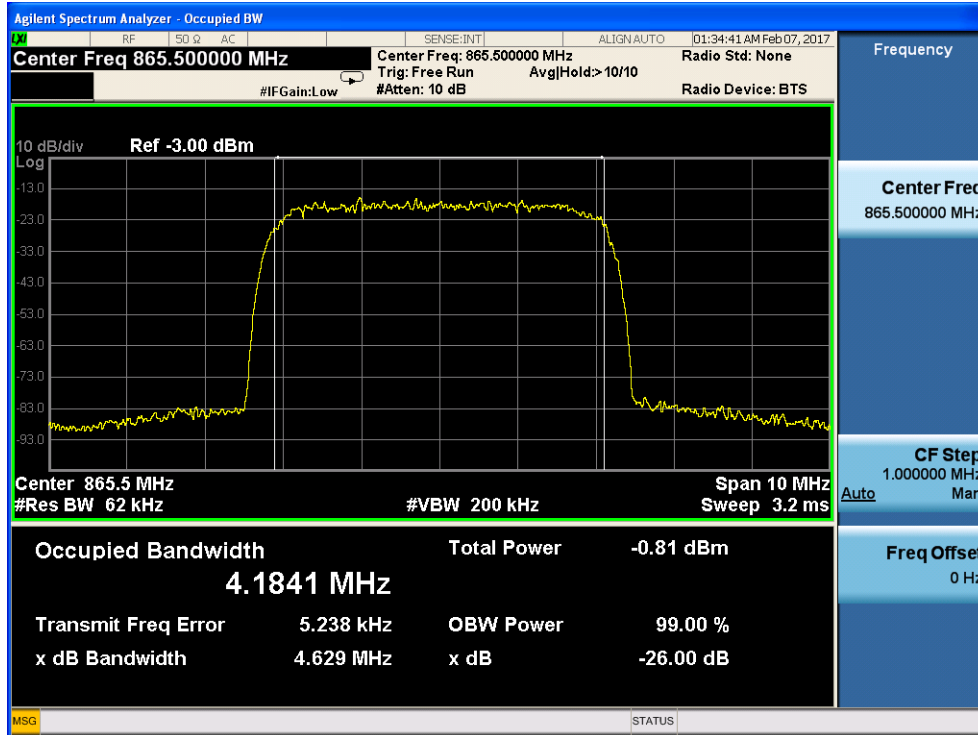

1.2.4 middle frequency—Output

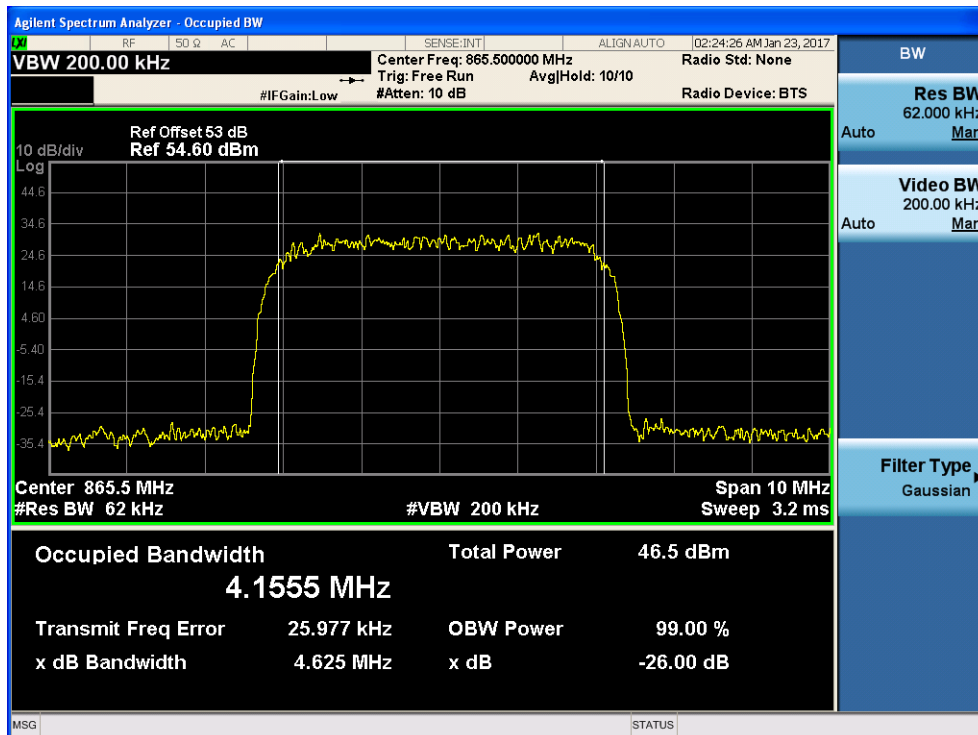



1.2.5 highest frequency—Input

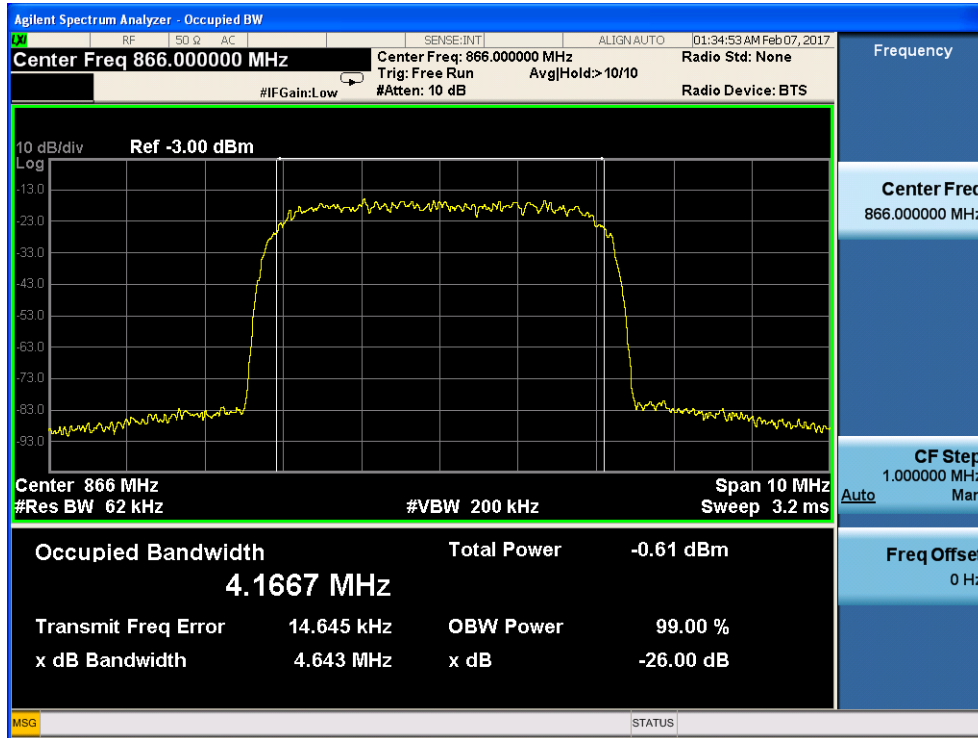

1.2.6 highest frequency—Output

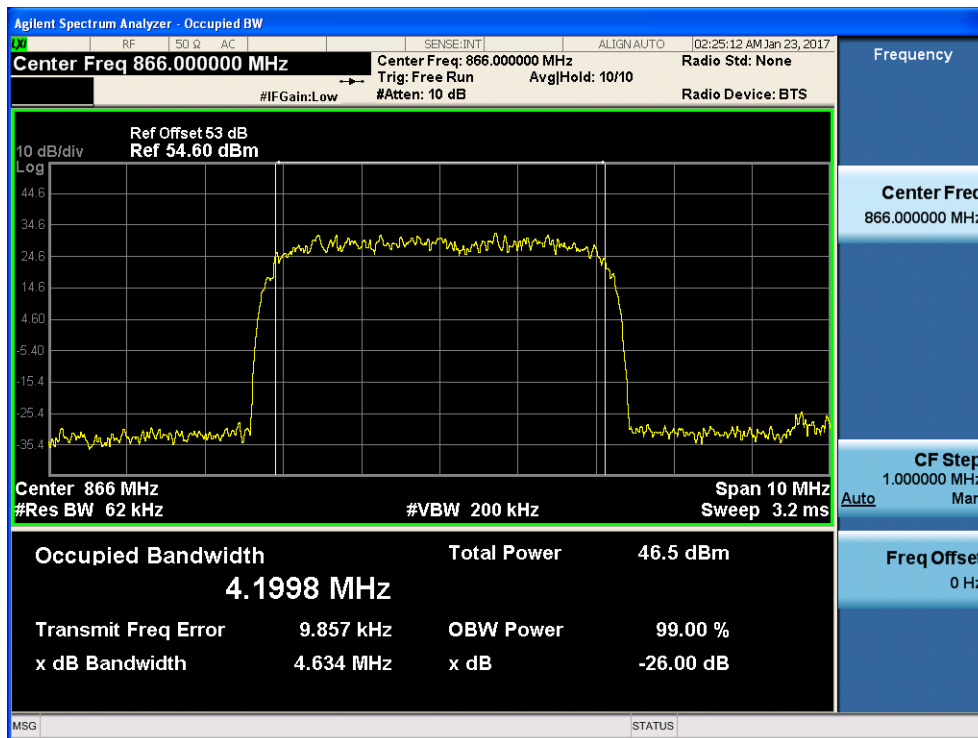



1.3 LTE Mode:

1.3.1 Lowest frequency—Input

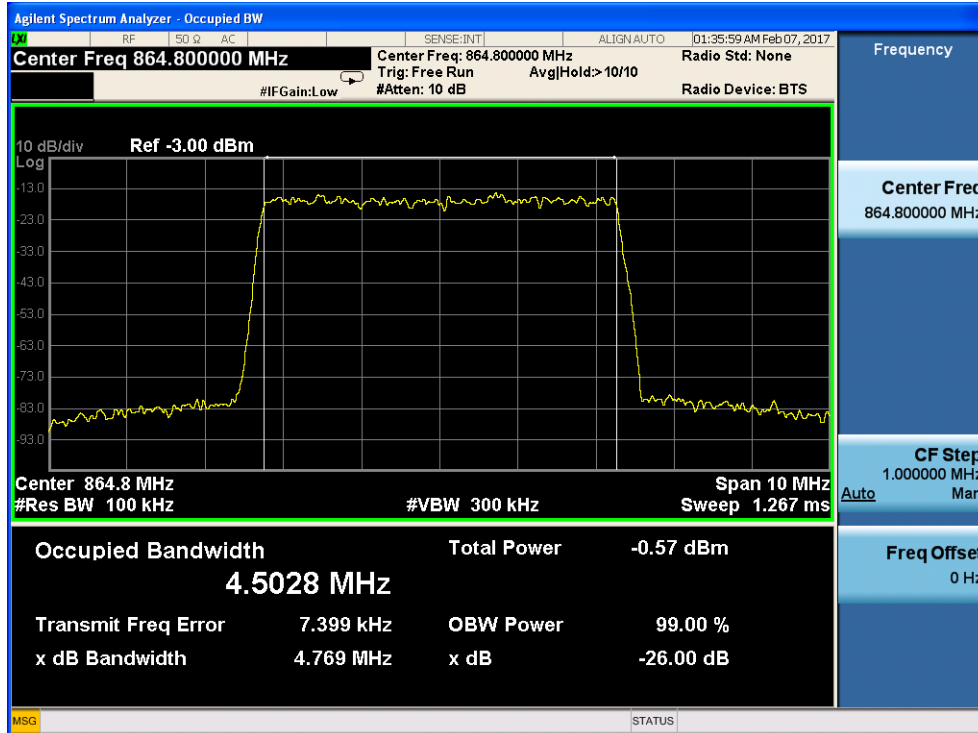

1.3.2 Lowest frequency—Output

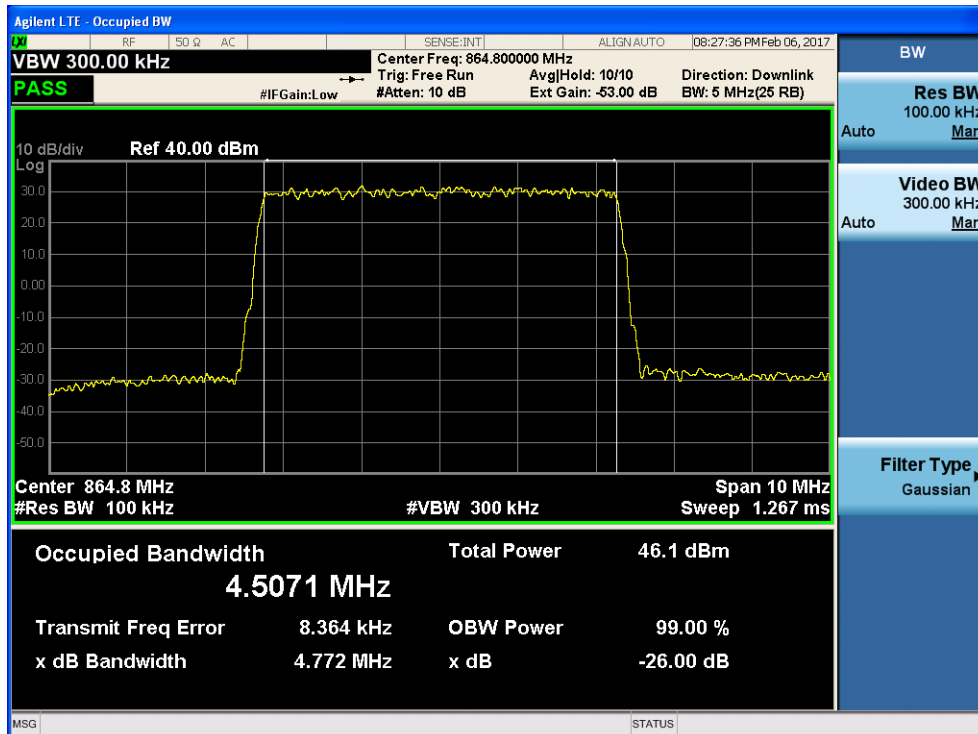

1.3.3 middle frequency-- Input

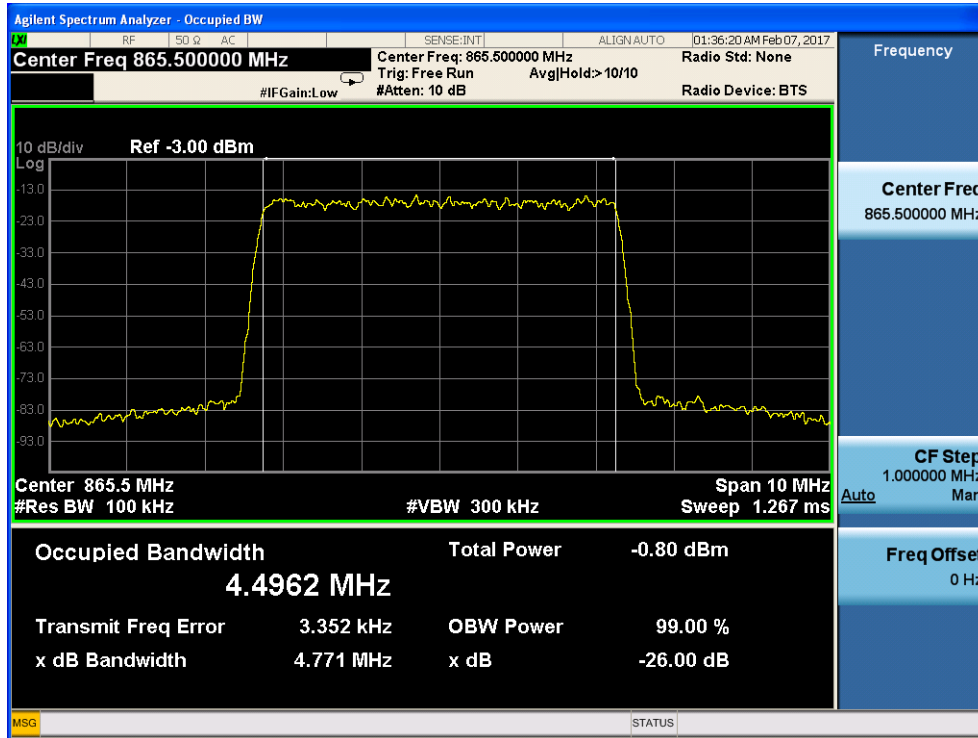

1.3.4 middle frequency-- Output

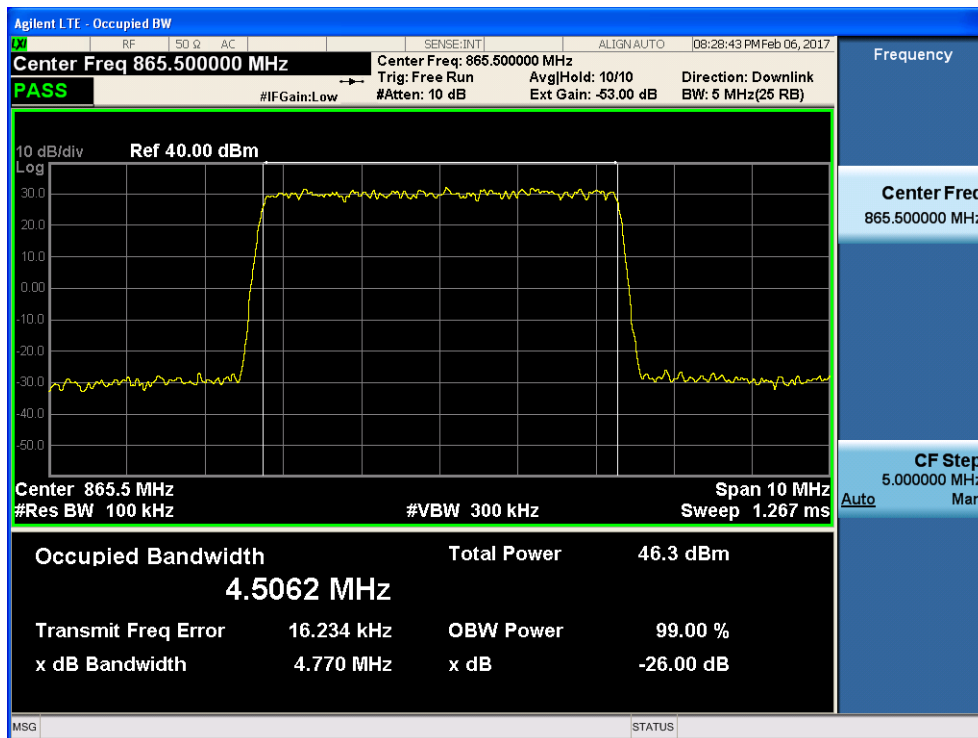



1.3.5 highest frequency-- Input

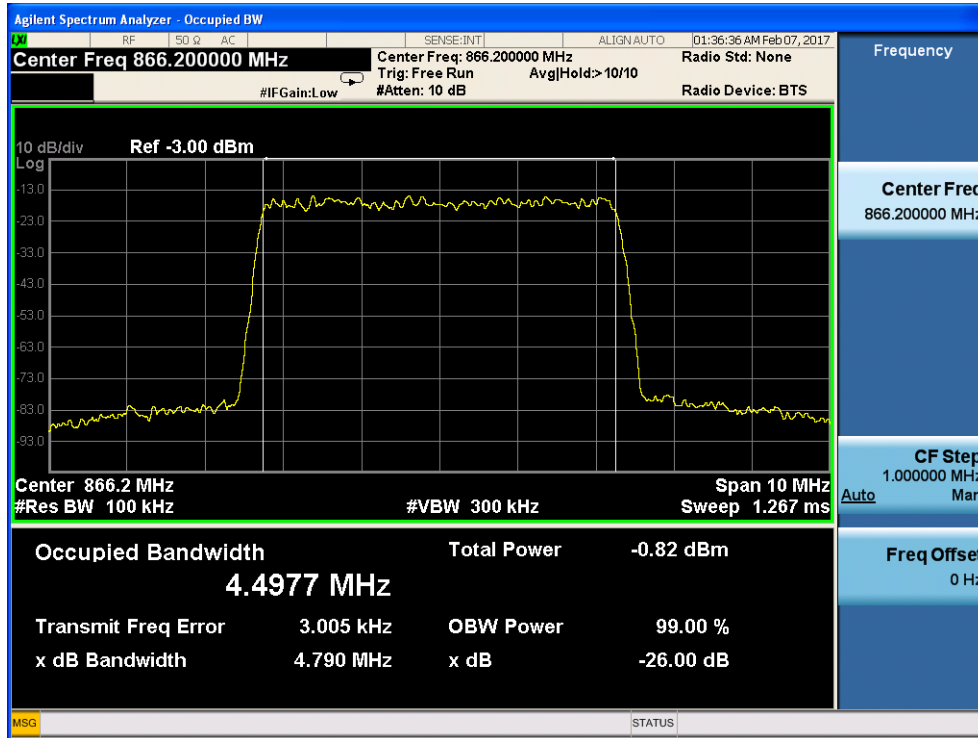

1.3.6 highest frequency-- Output

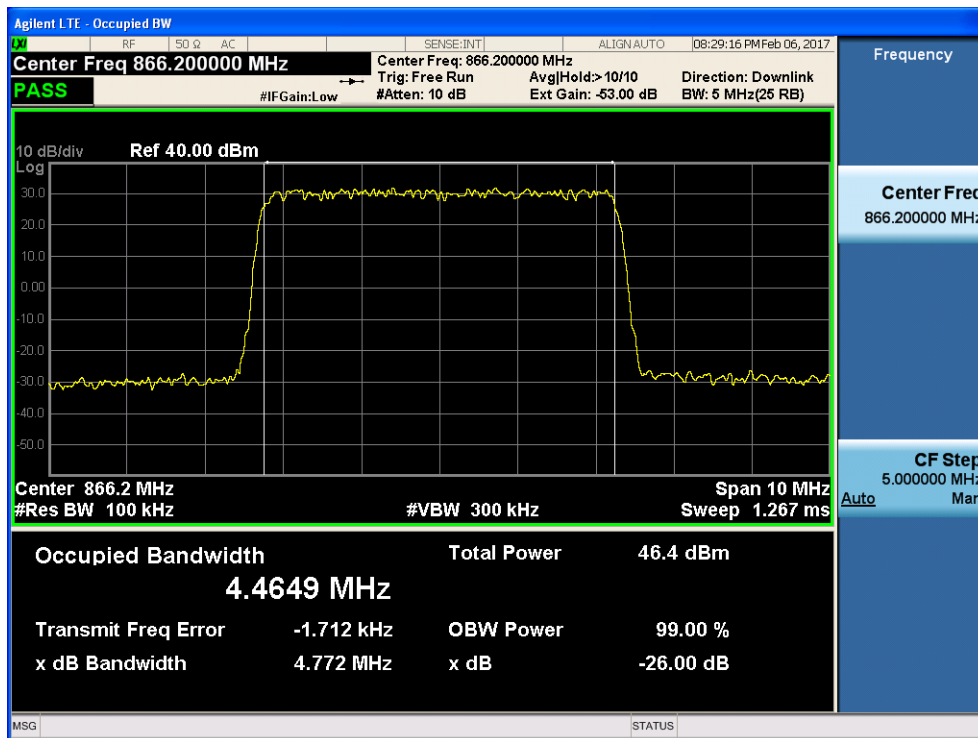

2. Downlink: 869MHz to 894MHz(GSM,CDMA,WCDMA,LTE)

2.1 GSM Mode:

2.1.1 lowest frequency— Input

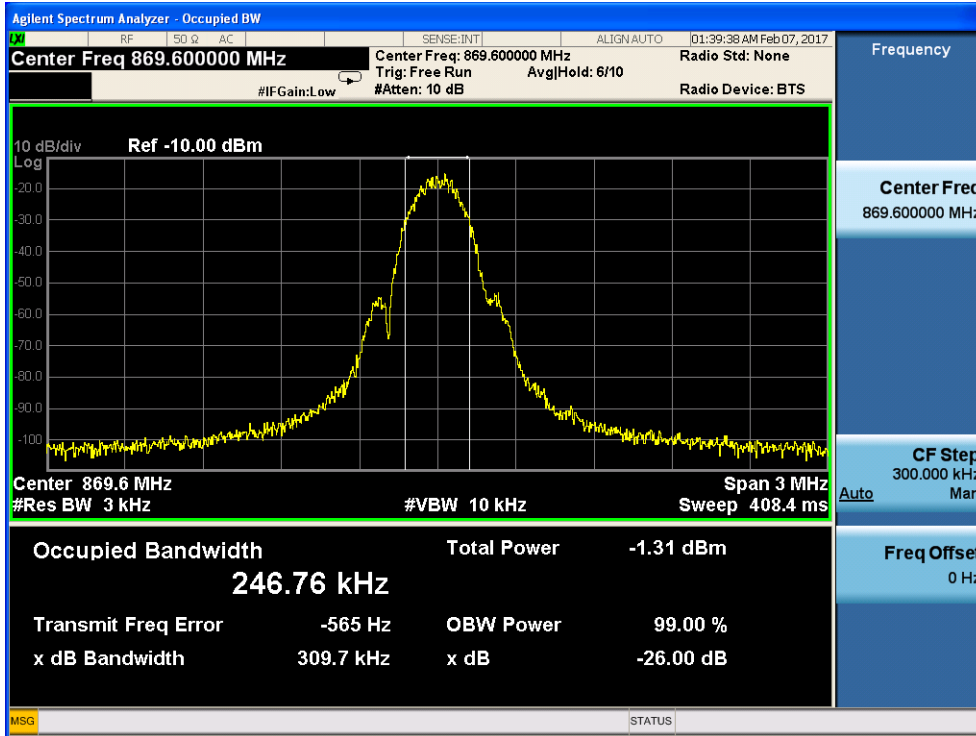

2.1.2 lowest frequency—Output

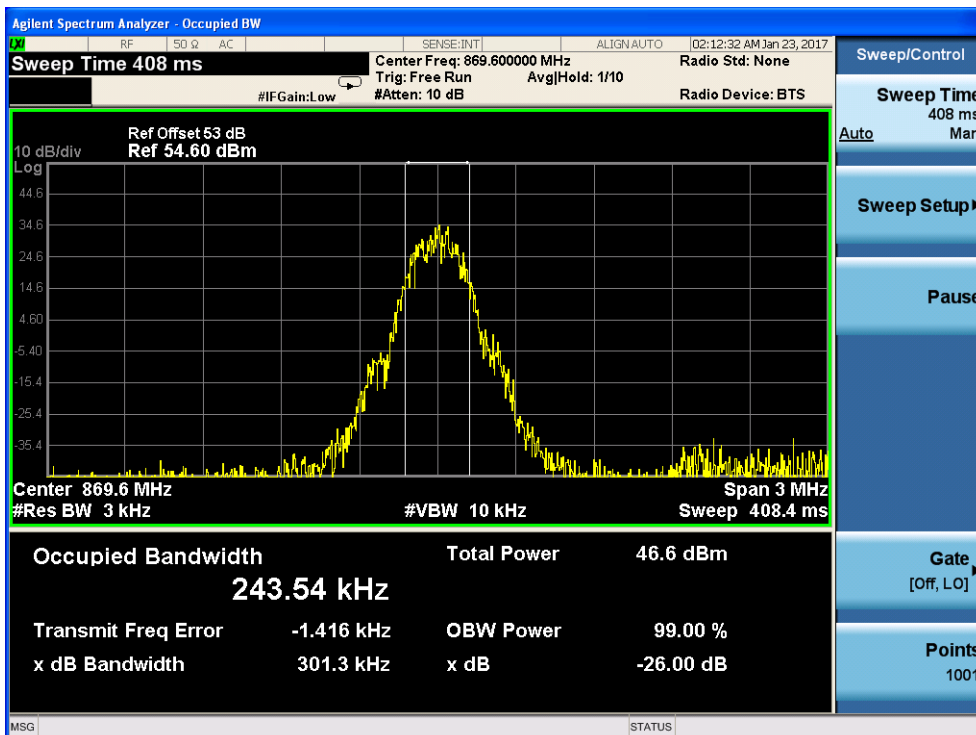

2.1.3 middle frequency—Input

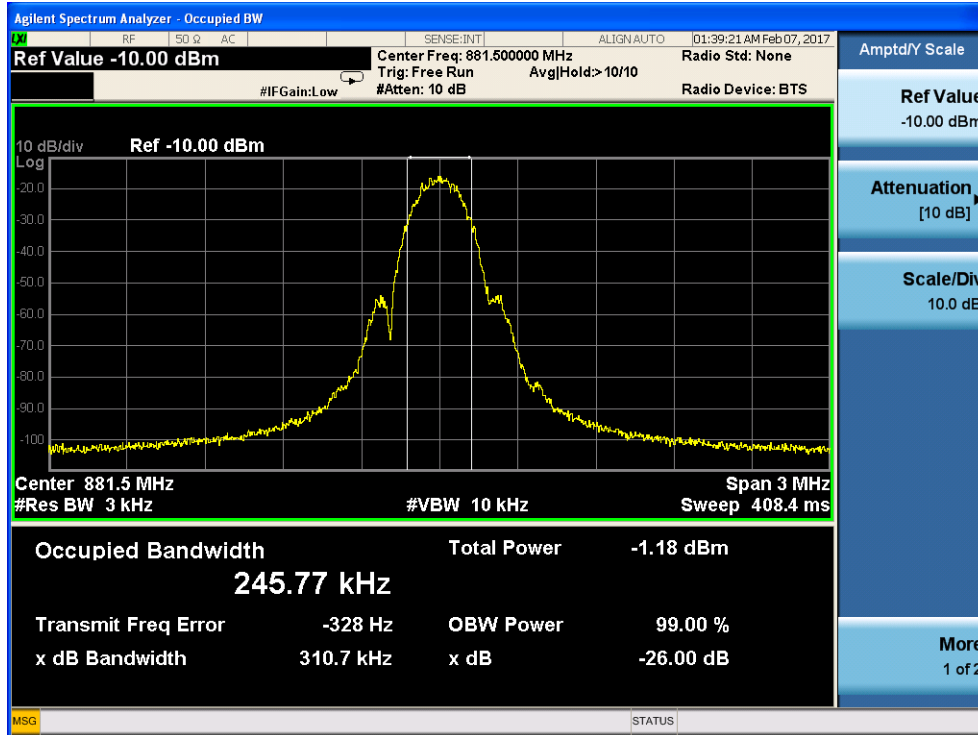

2.1.4 middle frequency—Output

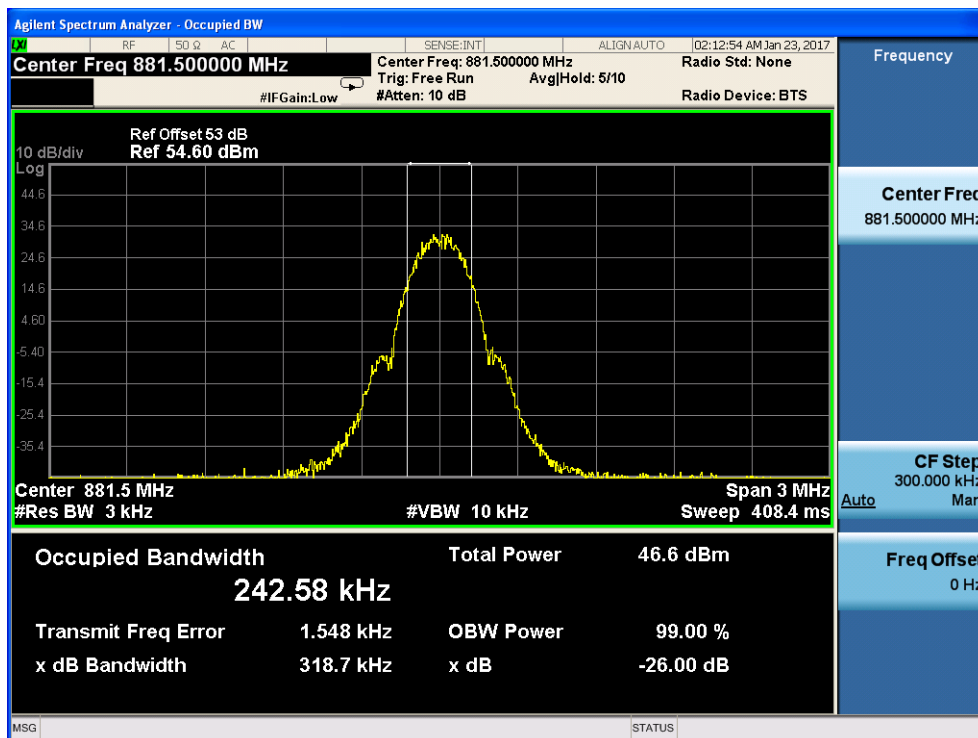



2.1.5 highest frequency—Input

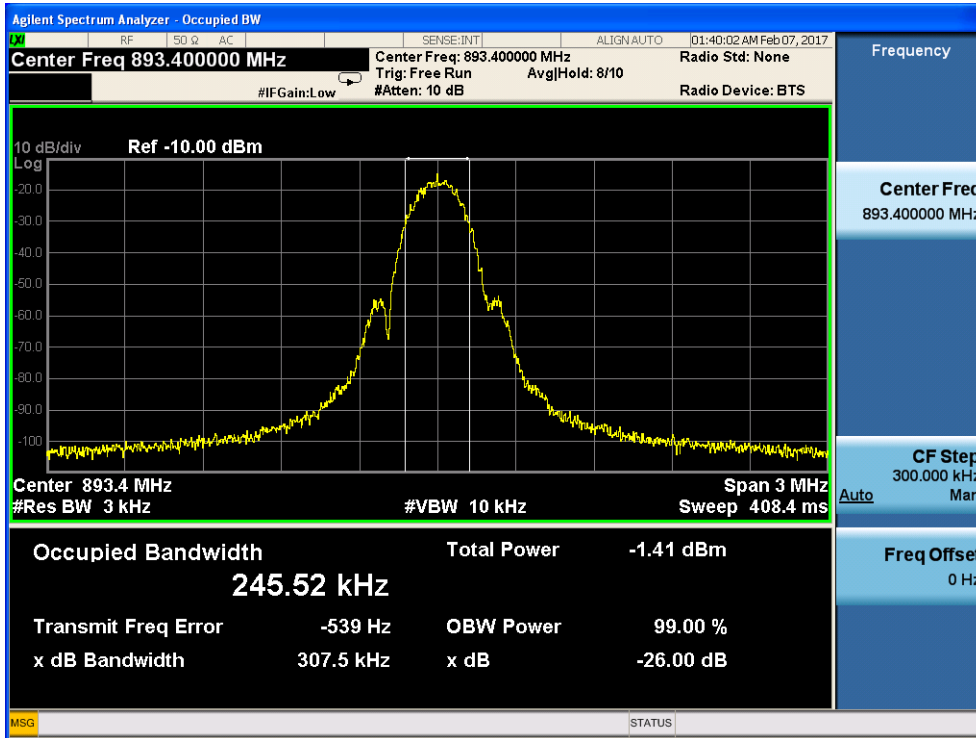

2.1.6 highest frequency—Output

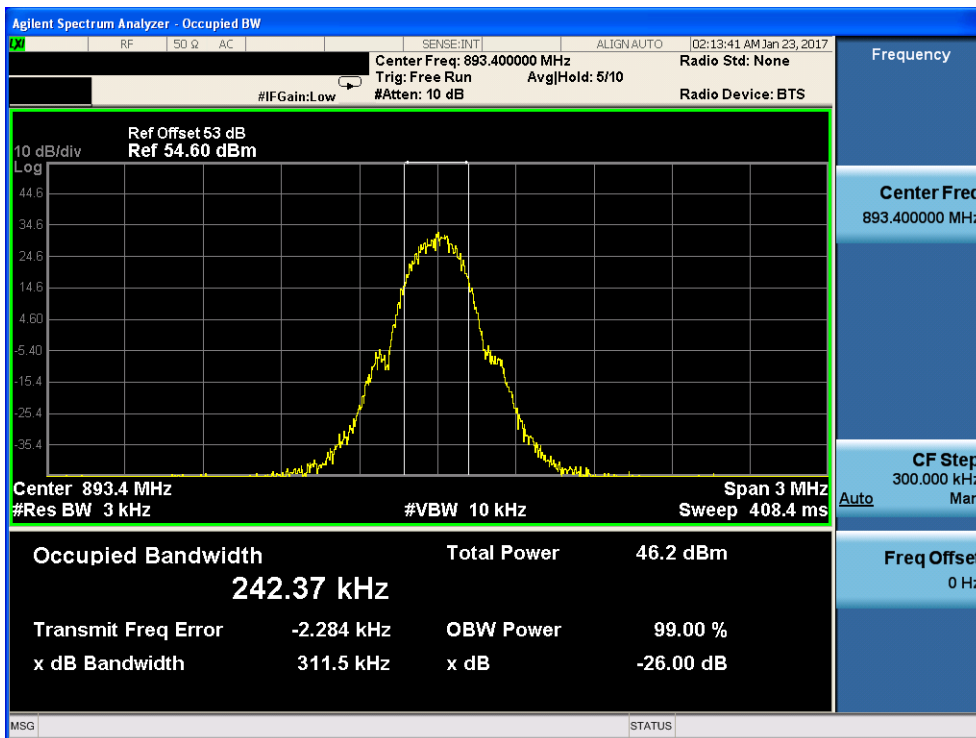

2.2 CDMA Mode:

2.2.1 lowest frequency— Input

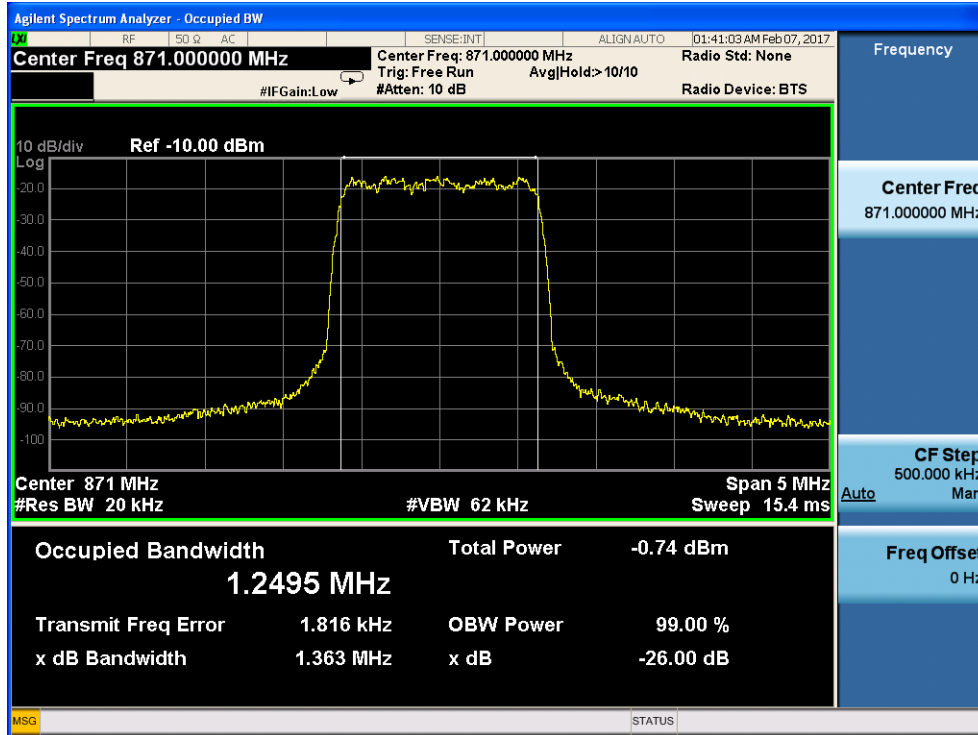

2.2.2 lowest frequency—Output

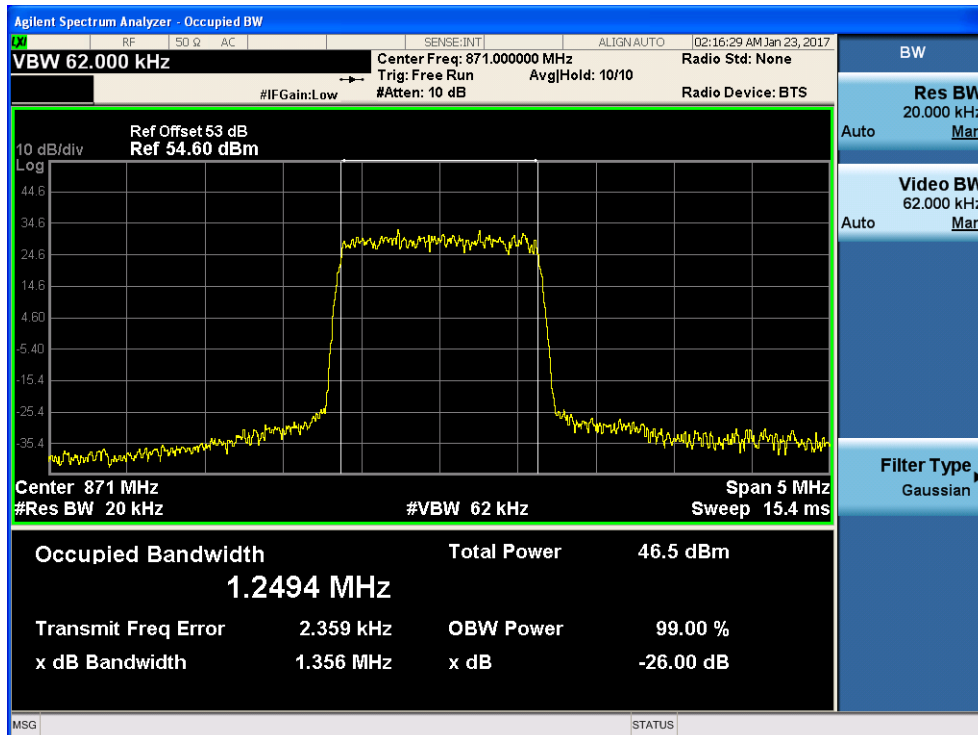

2.2.3 middle frequency—Input

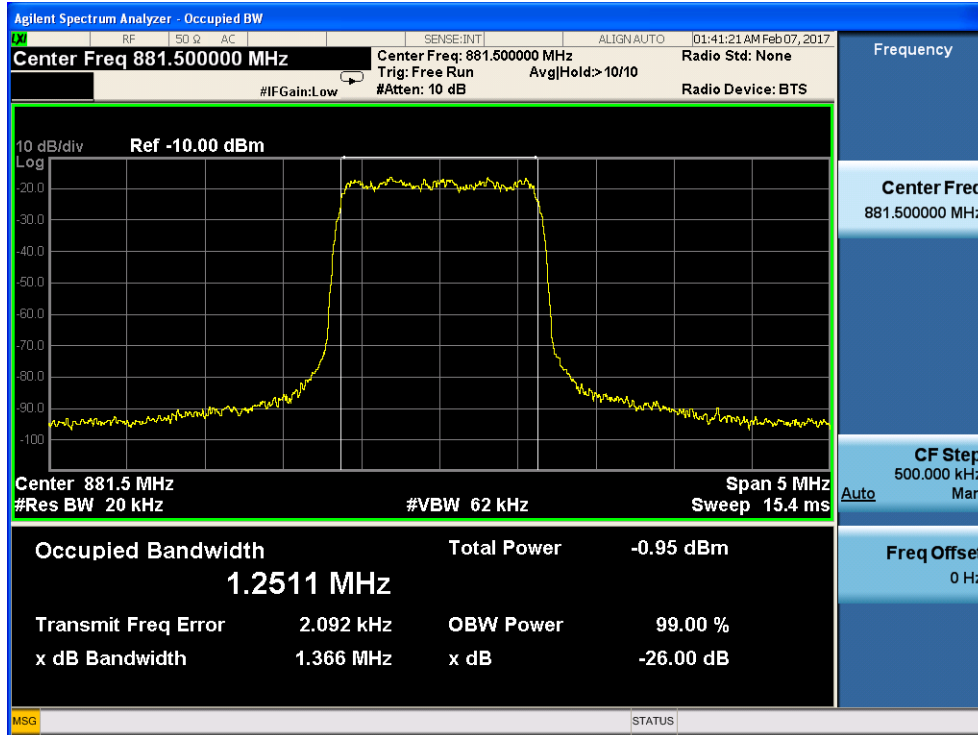

2.2.4 middle frequency—Output

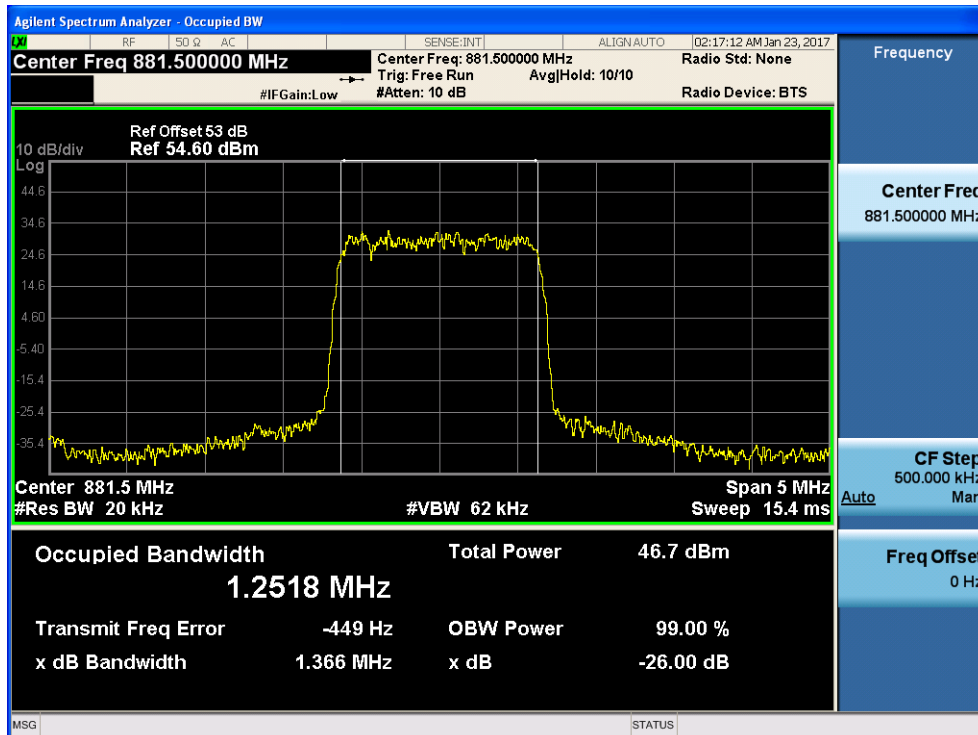





2.2.5 highest frequency—Input

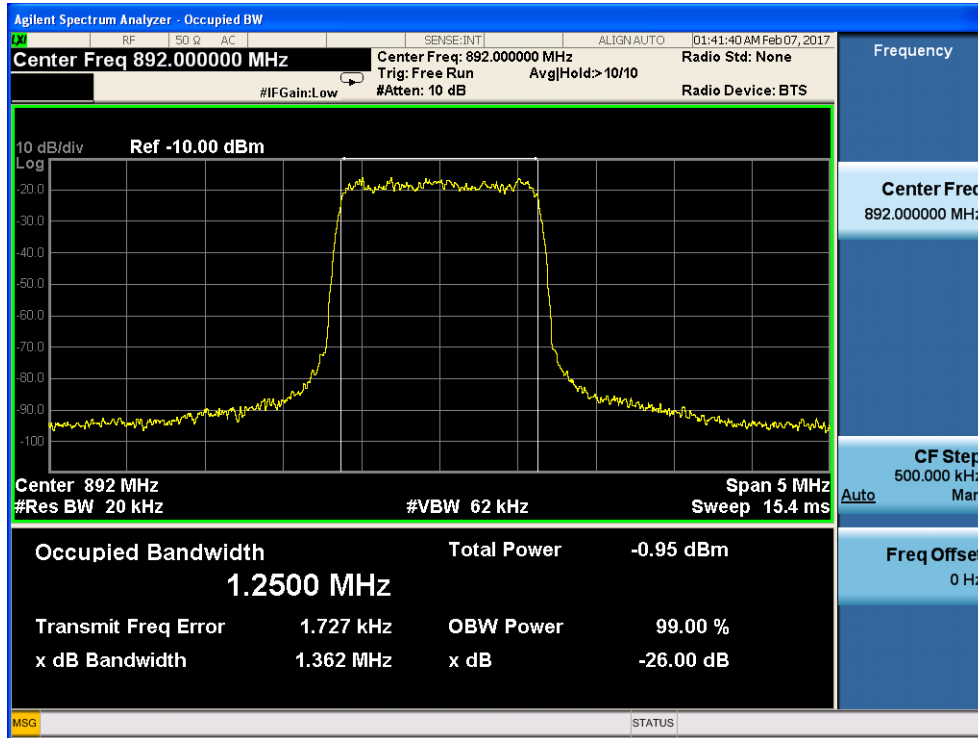

2.2.6 highest frequency—Output

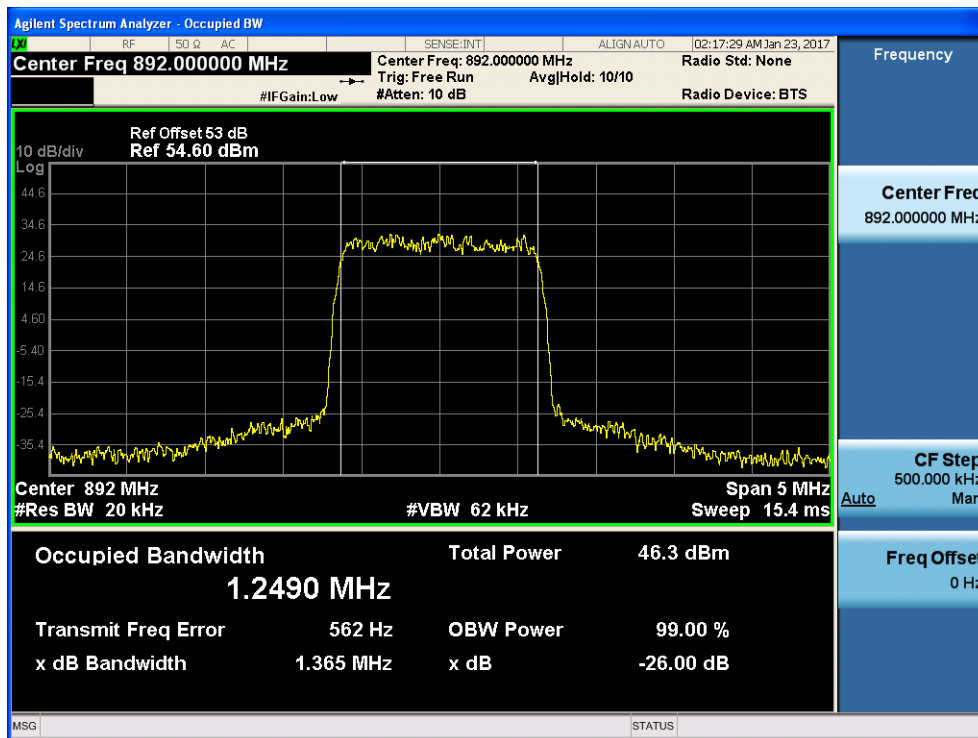

2.3 WCDMA Mode:

2.3.1 lowest frequency– Input

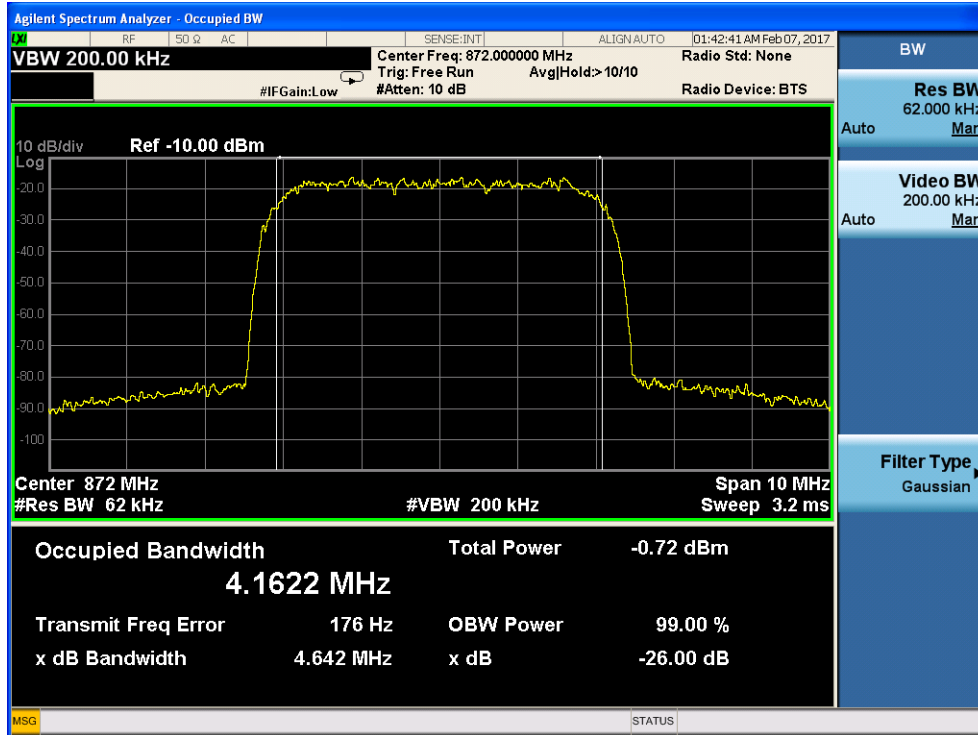

2.3.2 lowest frequency-- Output

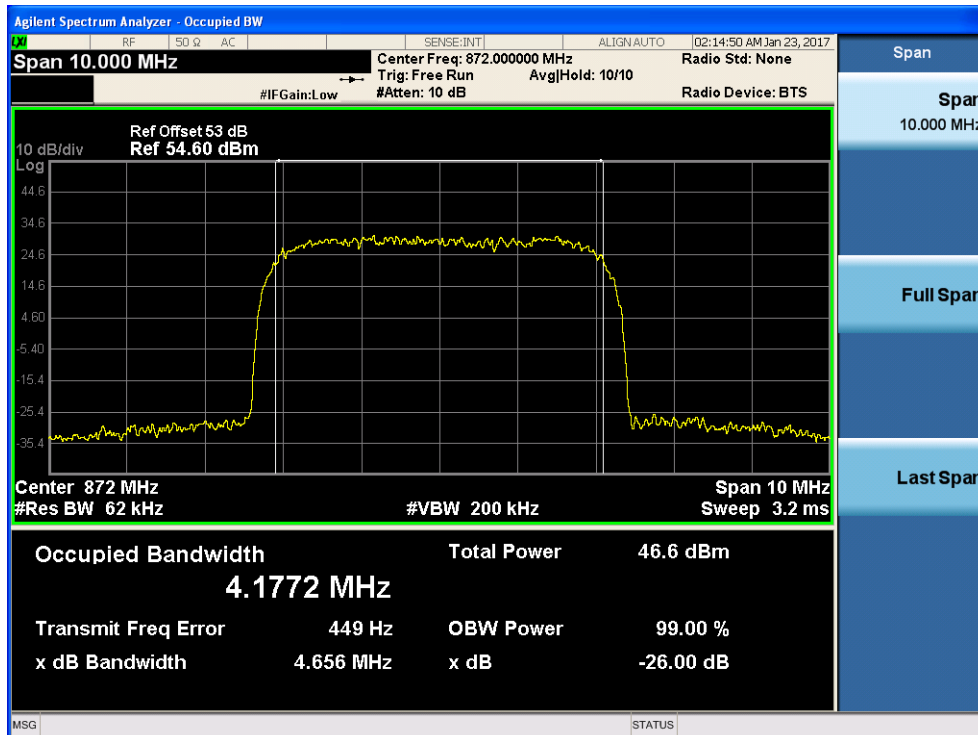

2.3.3 middle frequency-- Input

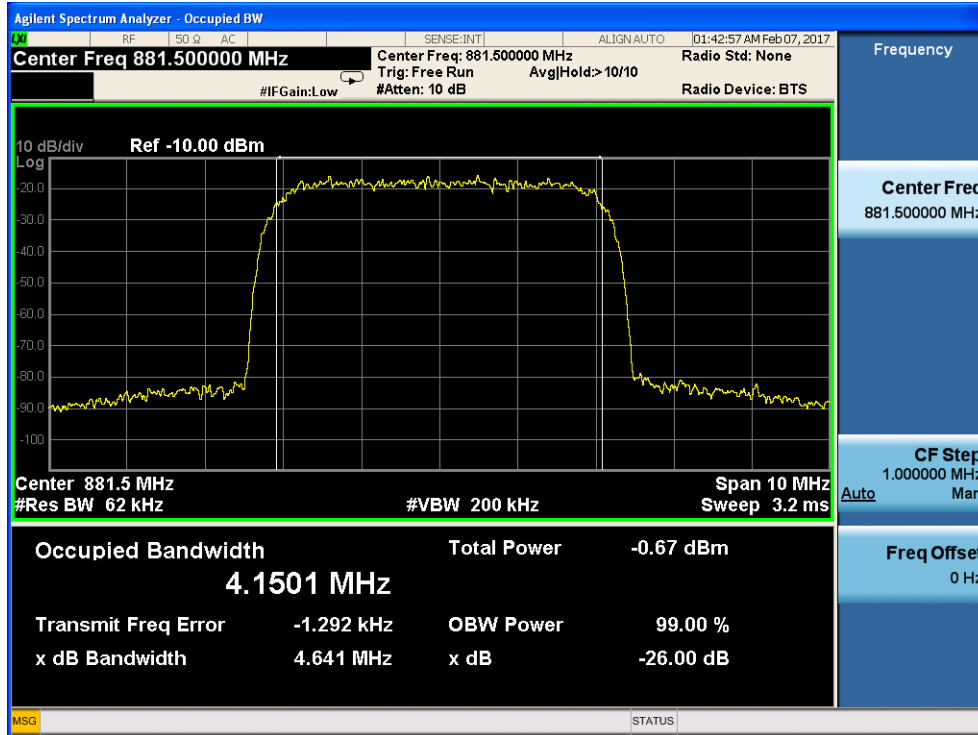

2.3.4 middle frequency-- Output

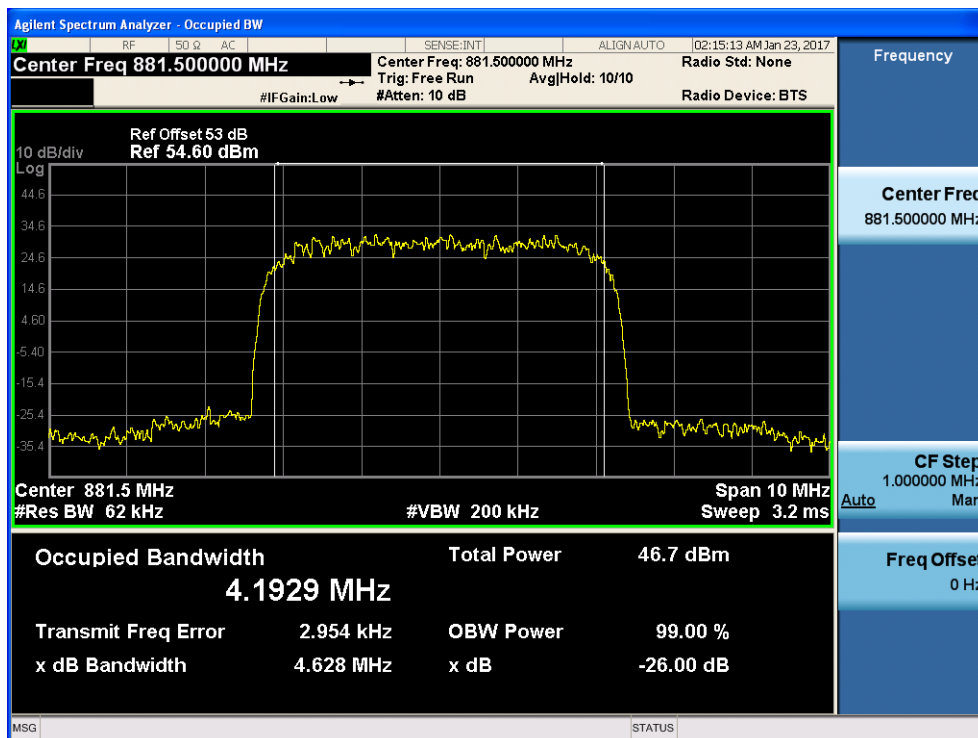



2.3.5 highest frequency—Input

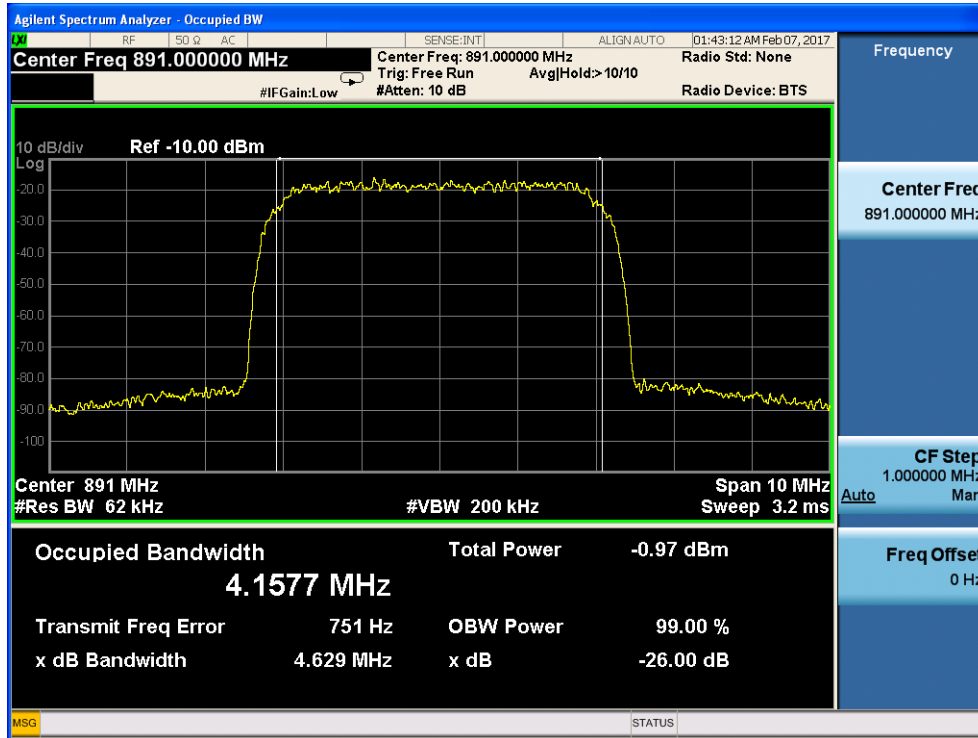

2.3.6 highest frequency--Output

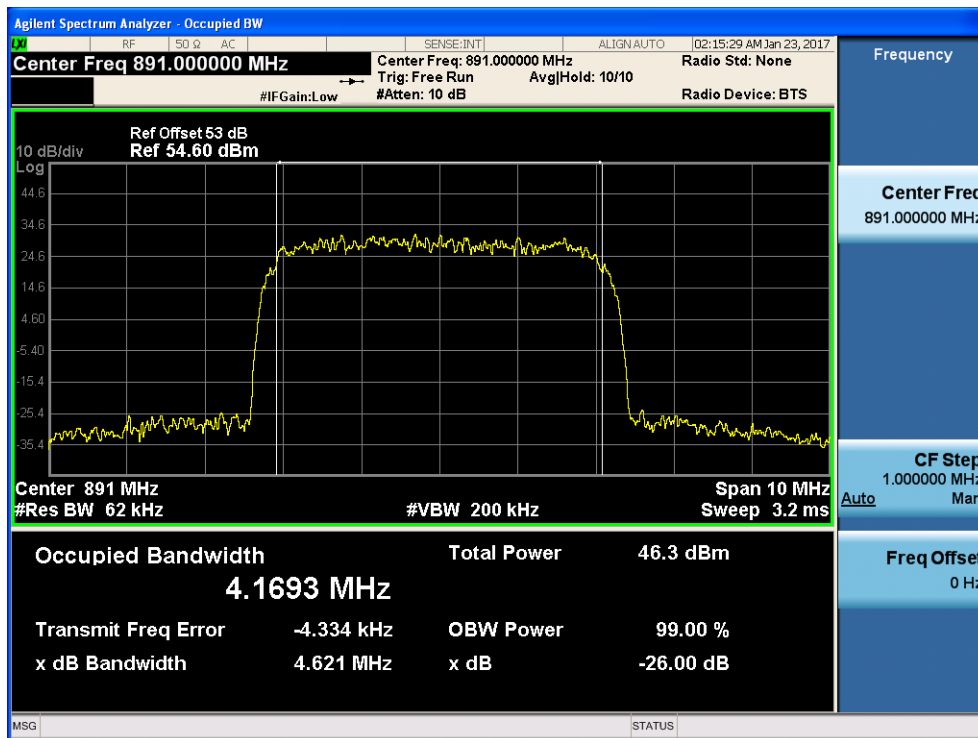

2.4 LTE Mode:

2.4.1 lowest frequency-- Input

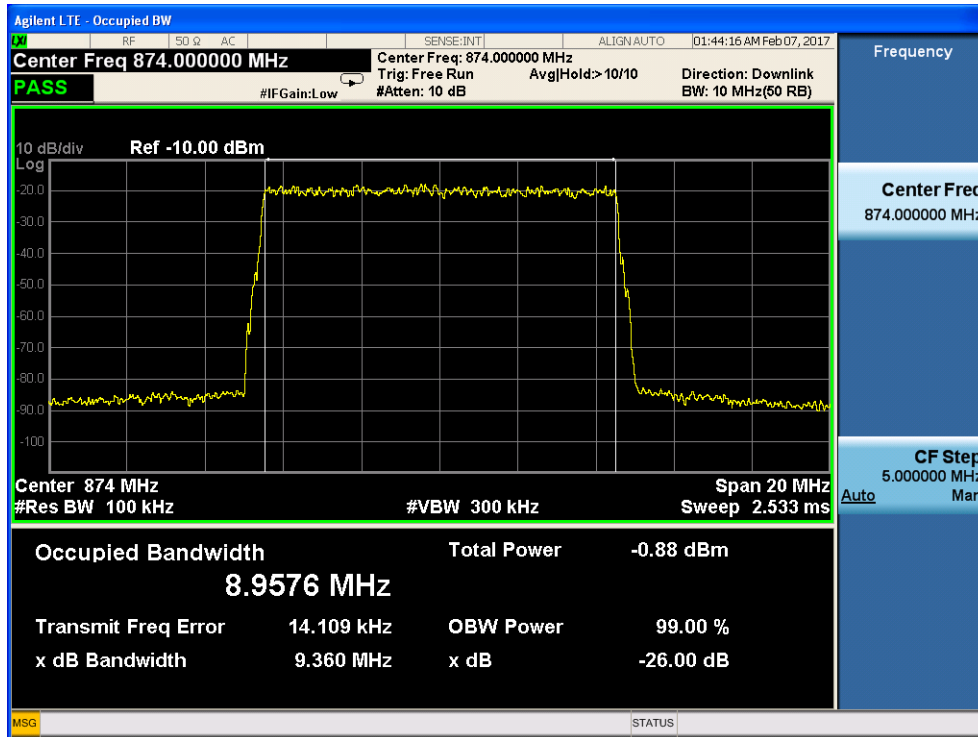

2.4.2 lowest frequency-- Output

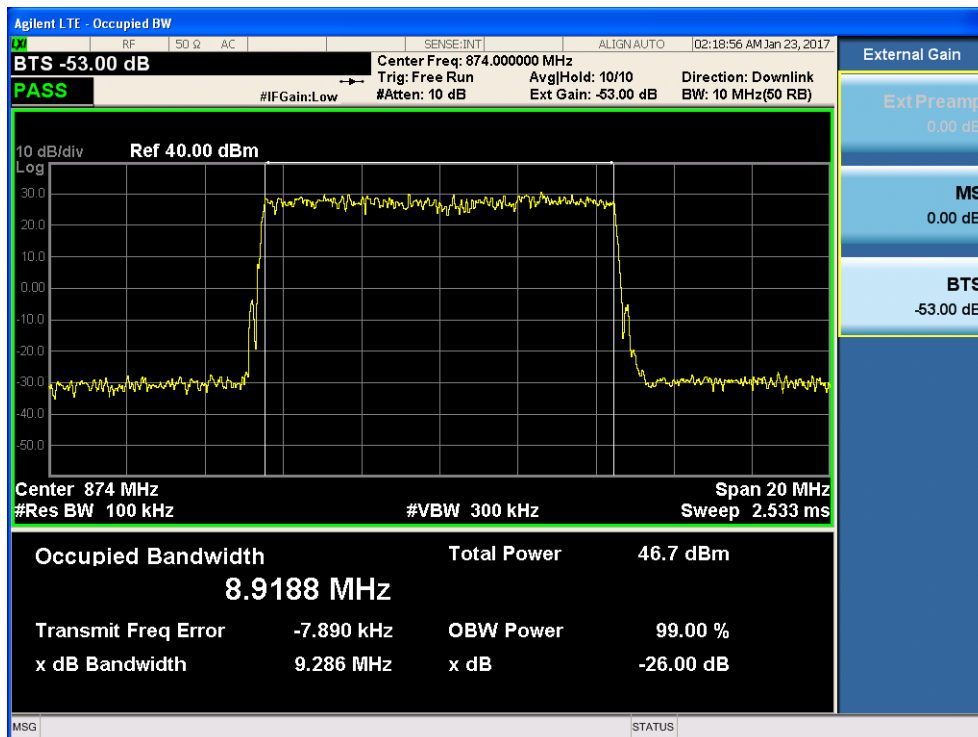

2.4.3 middle frequency-- Input

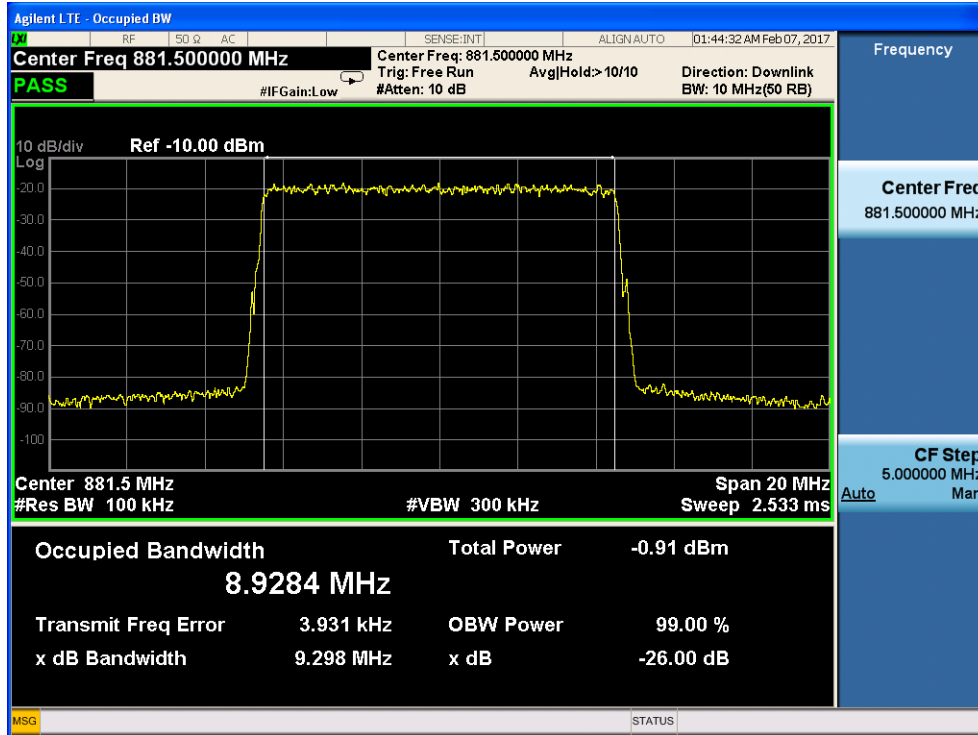

2.4.4 middle frequency-- Output

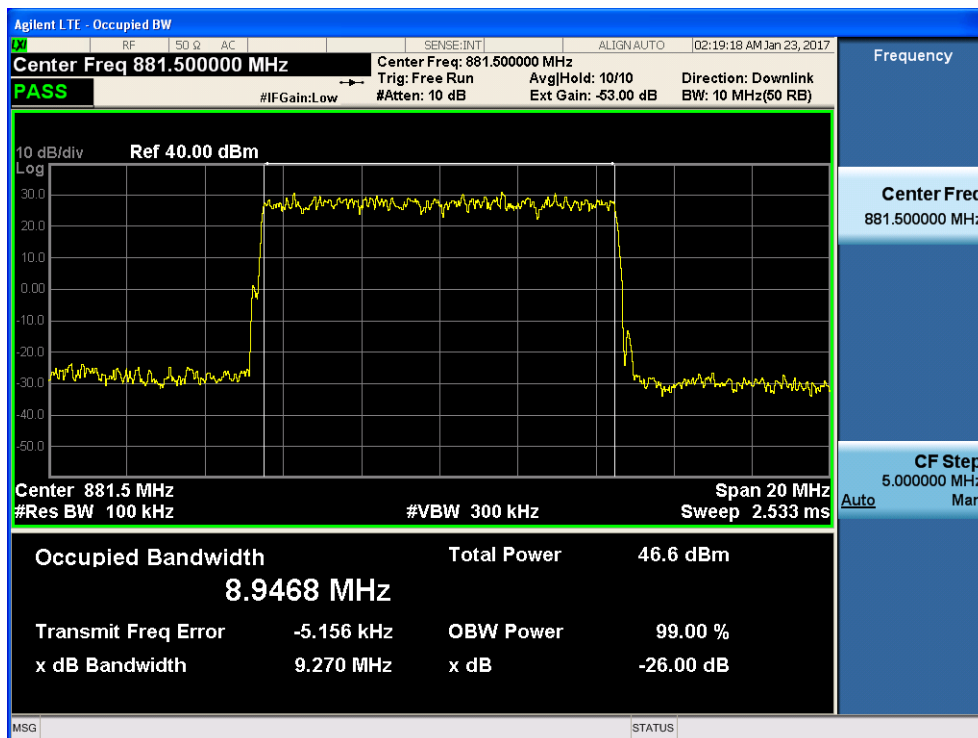

2.4.5 highest frequency—Input

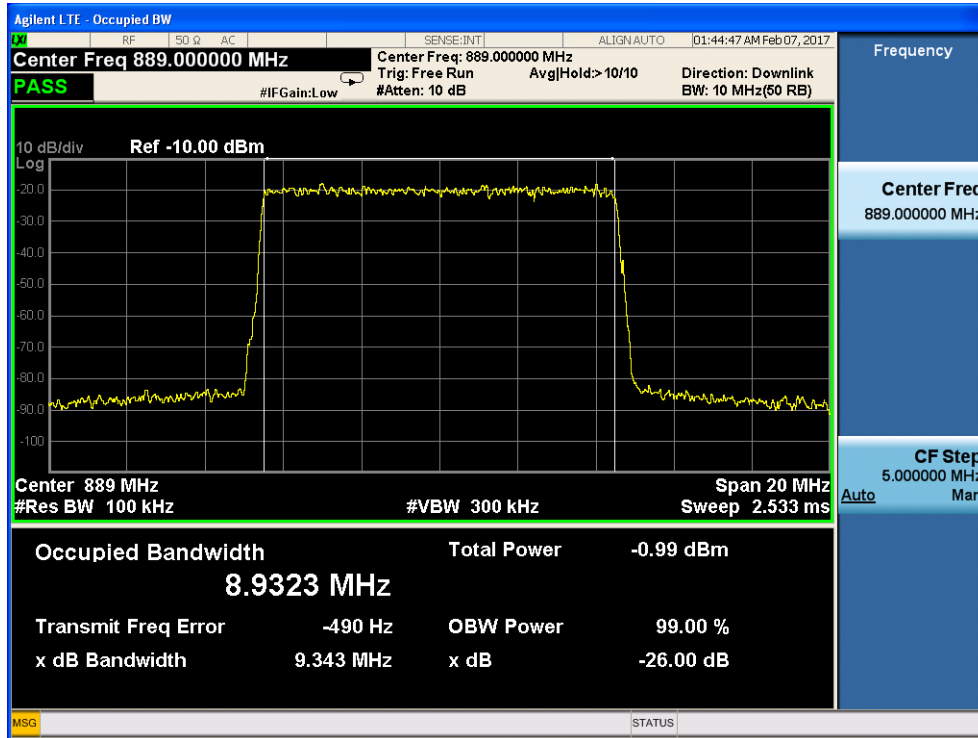

2.4.6 highest frequency--Output

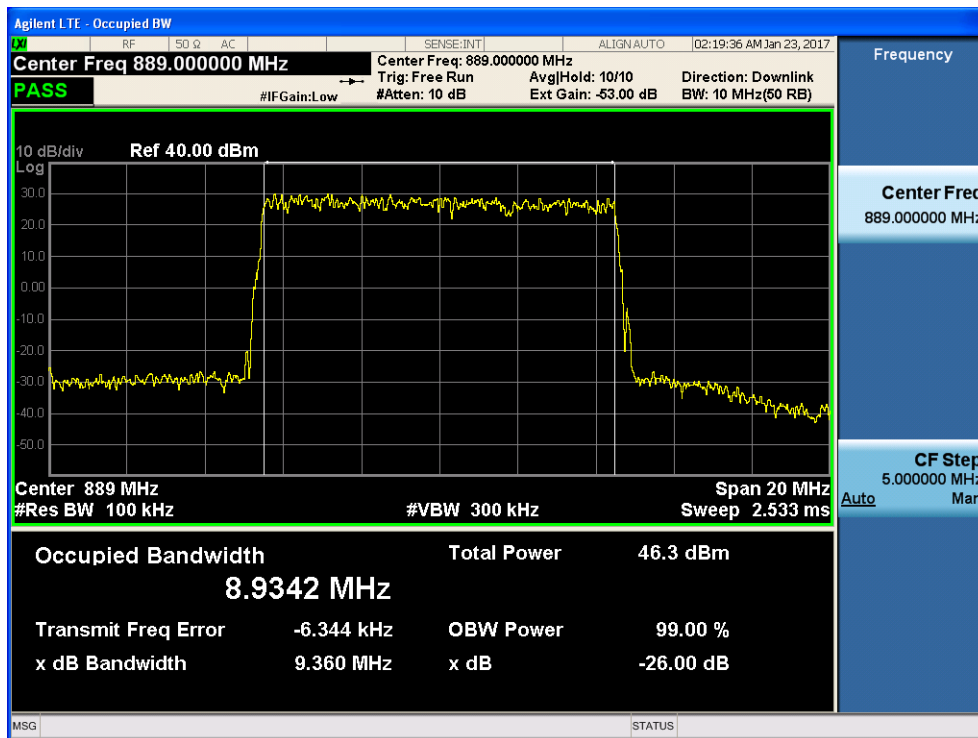



3. Downlink: 1930MHz to 1995MHz(GSM,CDMA,WCDMA,LTE)

3.1 GSM Mode:

3.1.1 lowest frequency-- Input

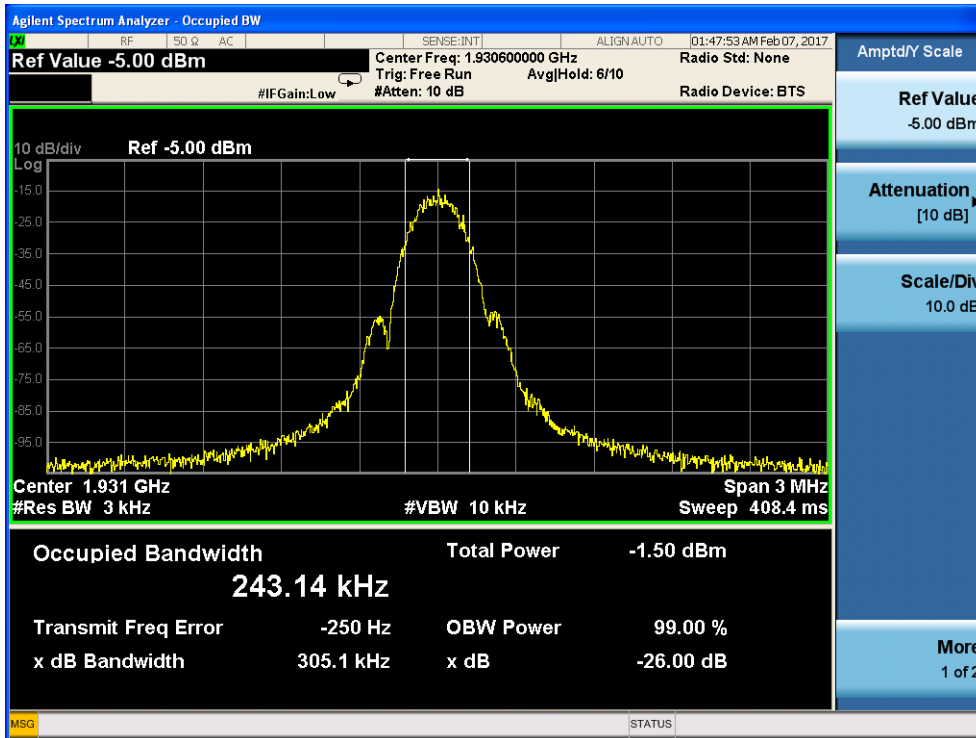

3.1.2 lowest frequency-- Output

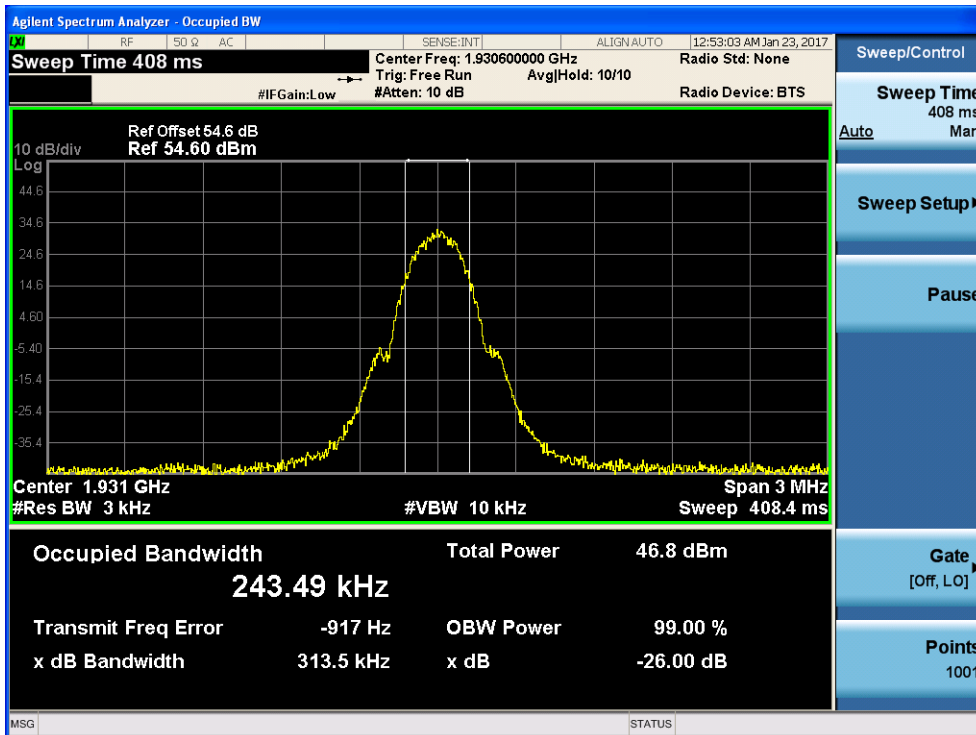



3.1.3 middle frequency-- Input

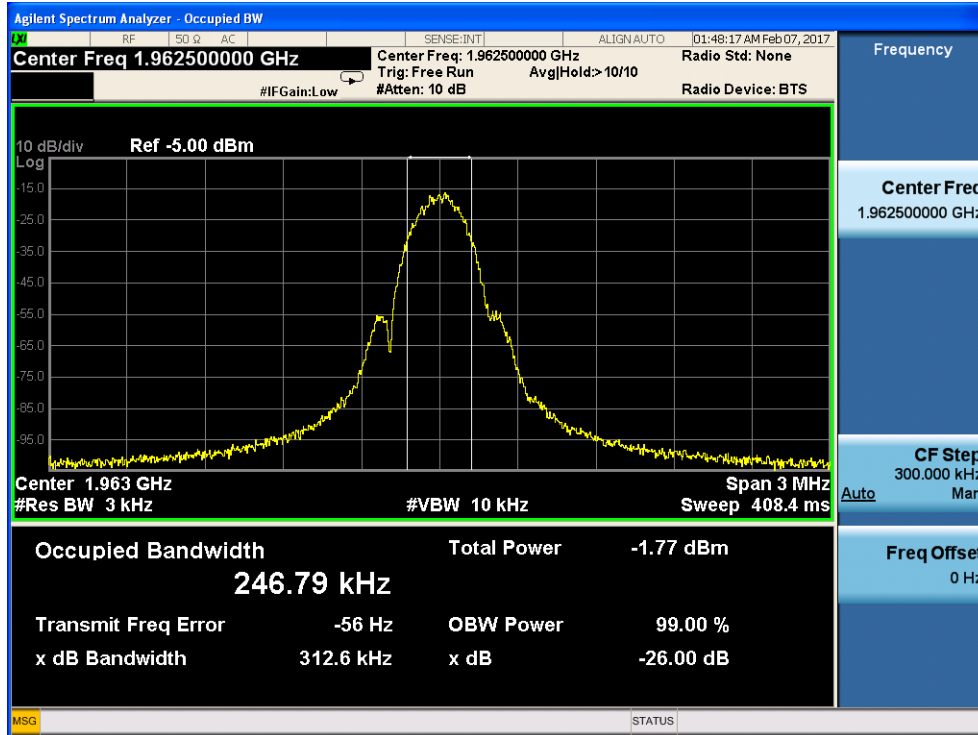

3.1.4 middle frequency-- Output

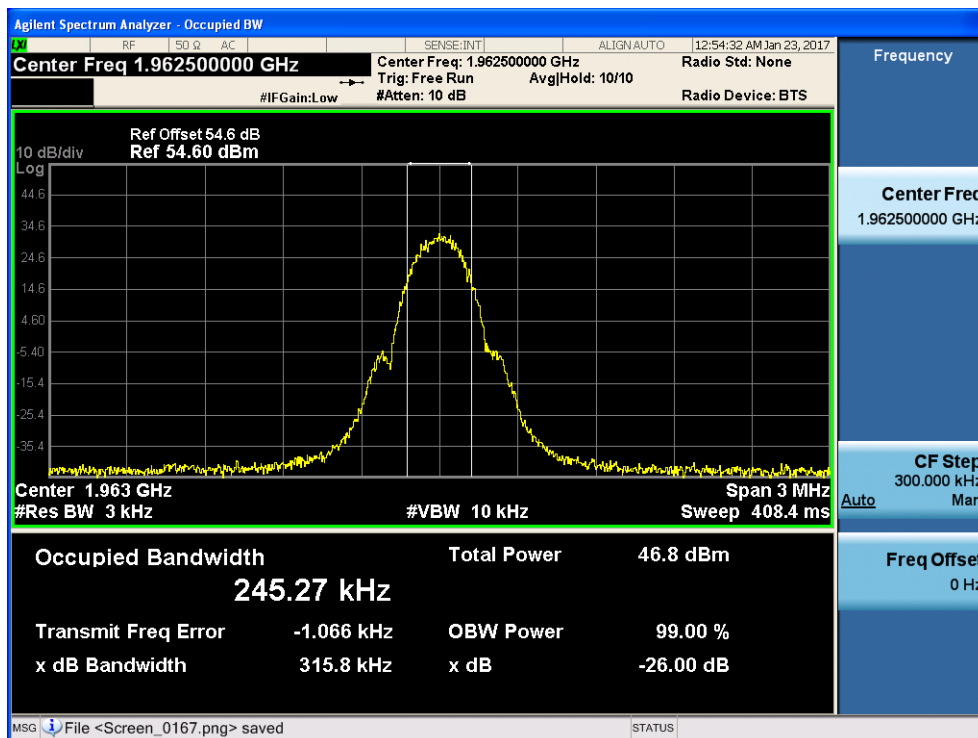

### 3.1.5 highest frequency—Input

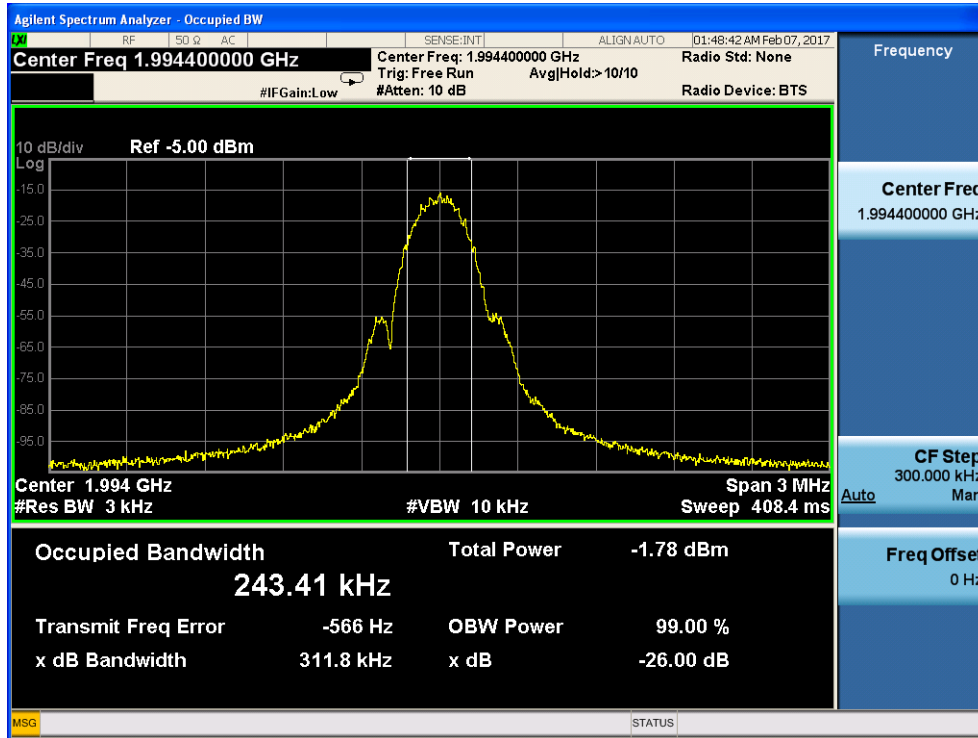

### 3.1.6 highest frequency--Output

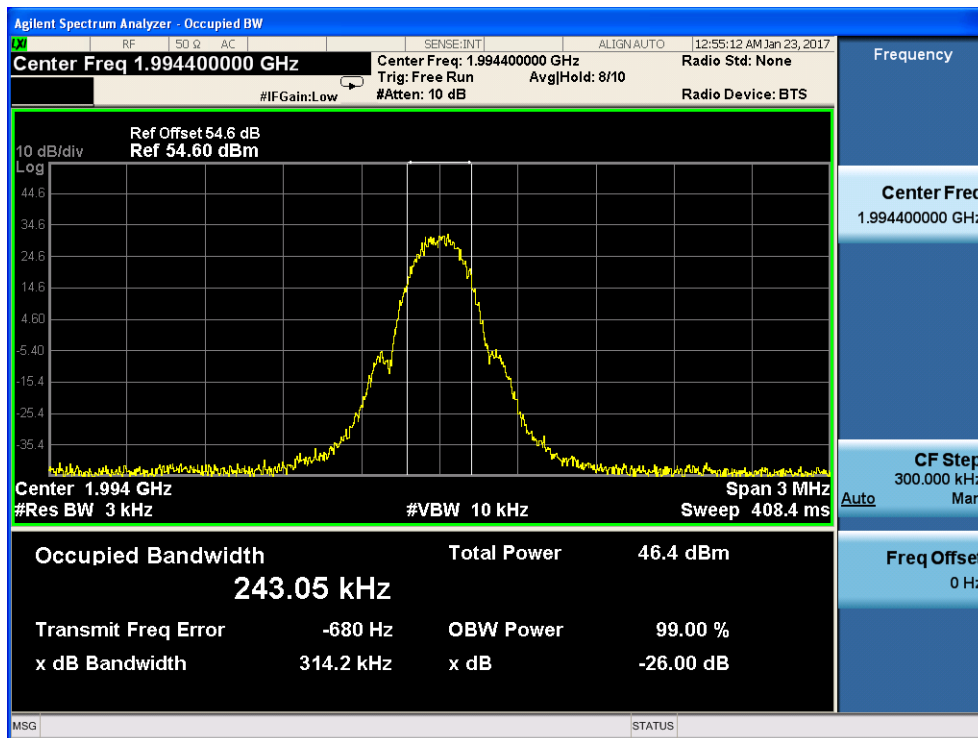

3.2 CDMA Mode:

3.2.1 lowest frequency– Input

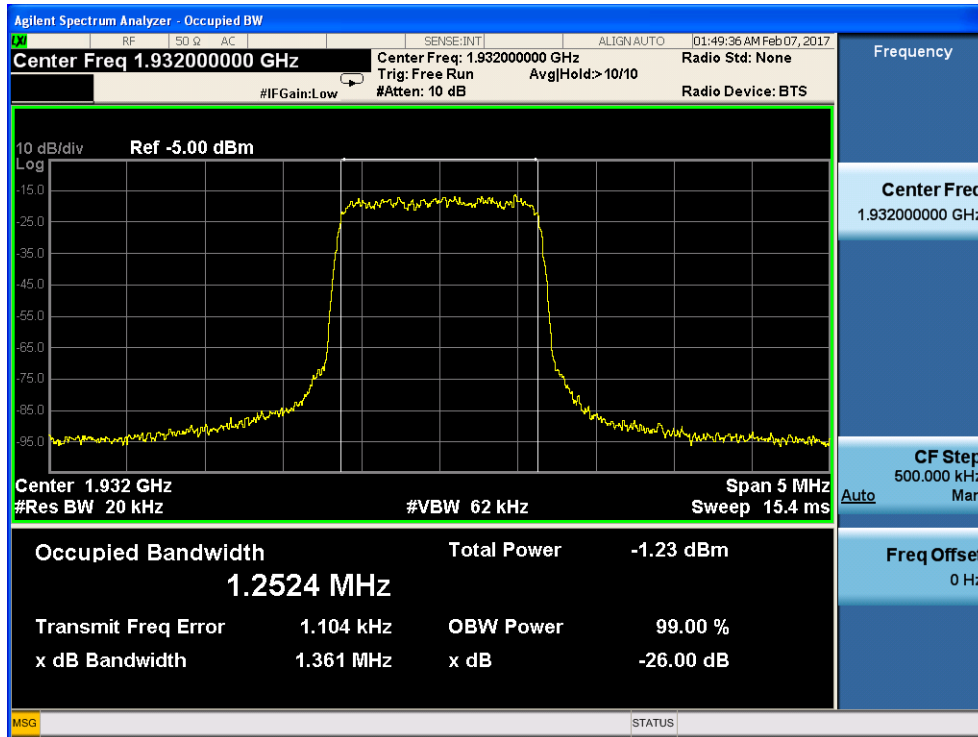

3.2.2 lowest frequency-- Output

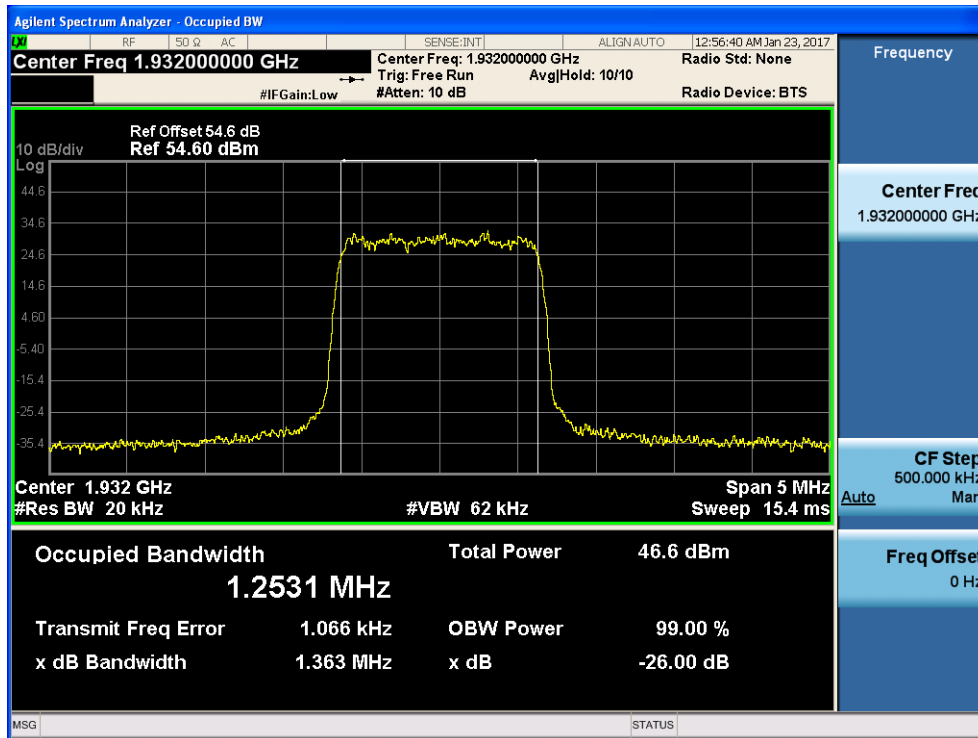

3.2.3 middle frequency-- Input

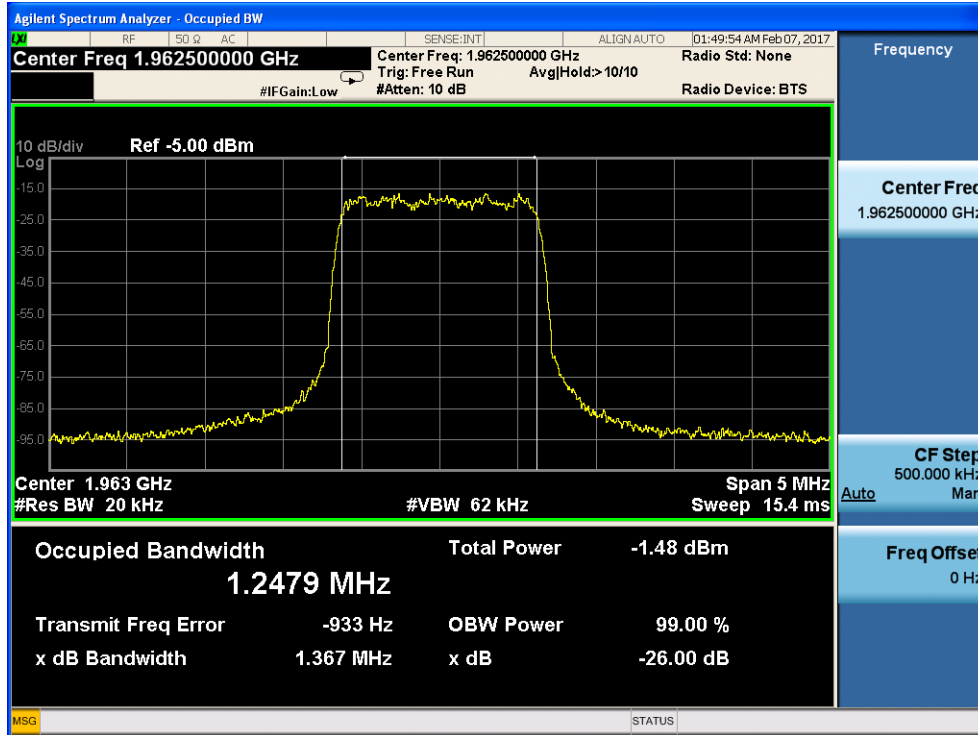

3.2.4 middle frequency-- Output

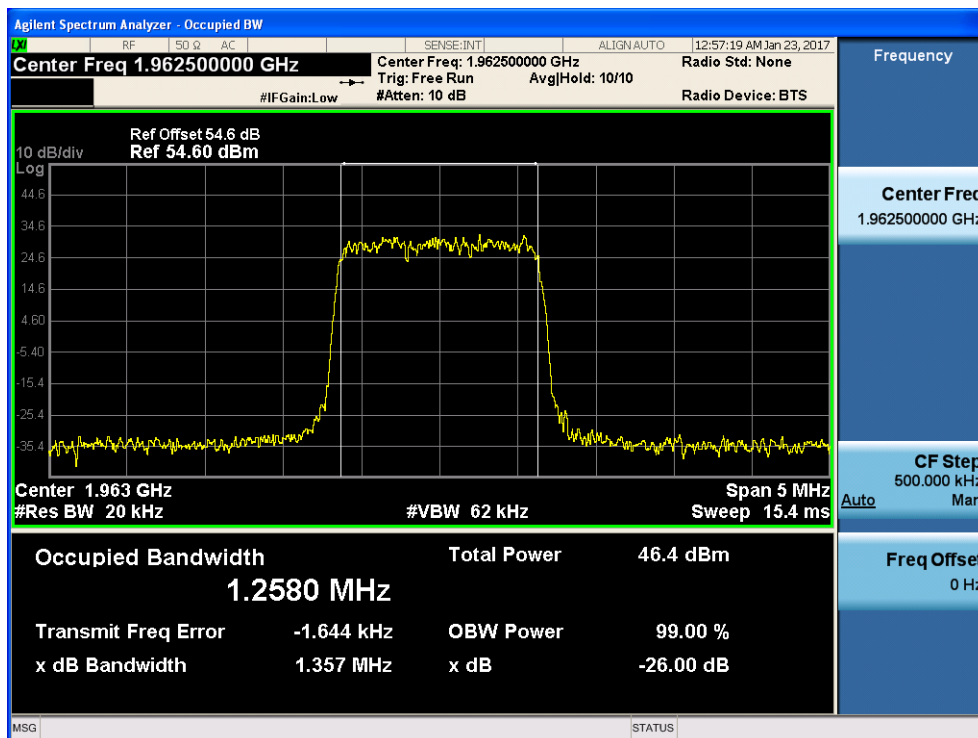

### 3.2.5 highest frequency—Input

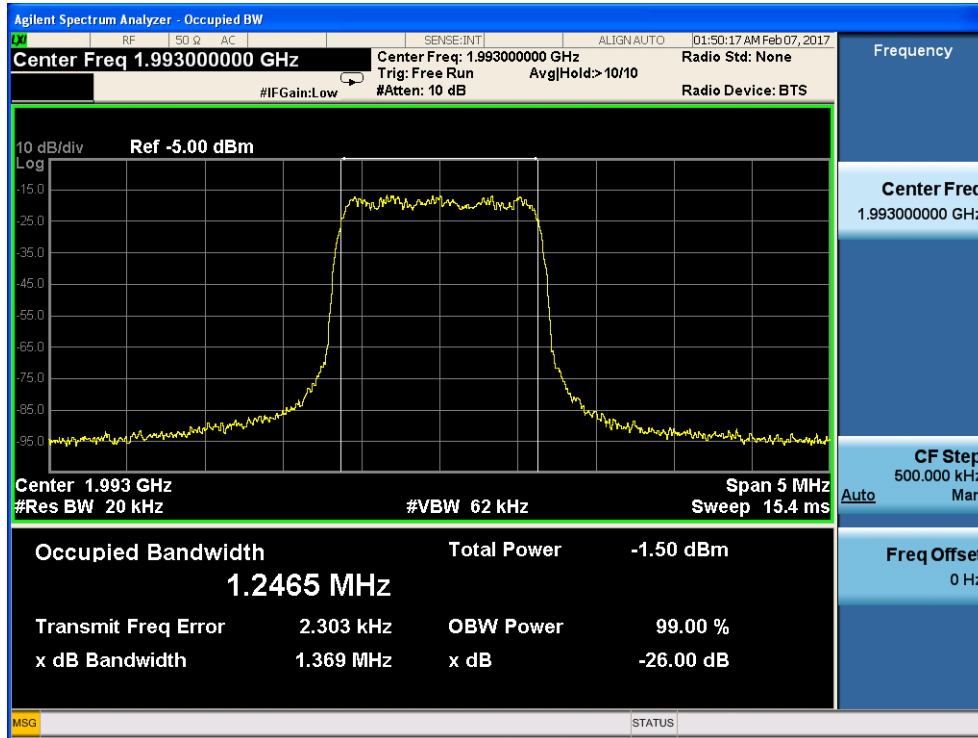

### 3.2.6 highest frequency--Output

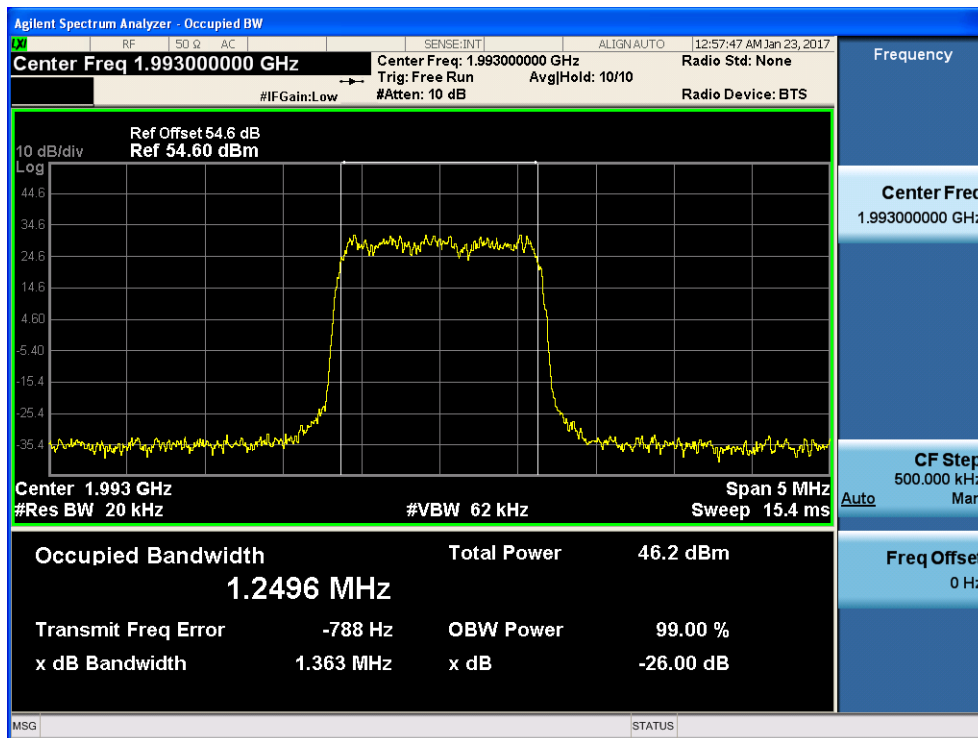

3.3 WCDMA Mode:

3.3.1 lowest frequency– Input

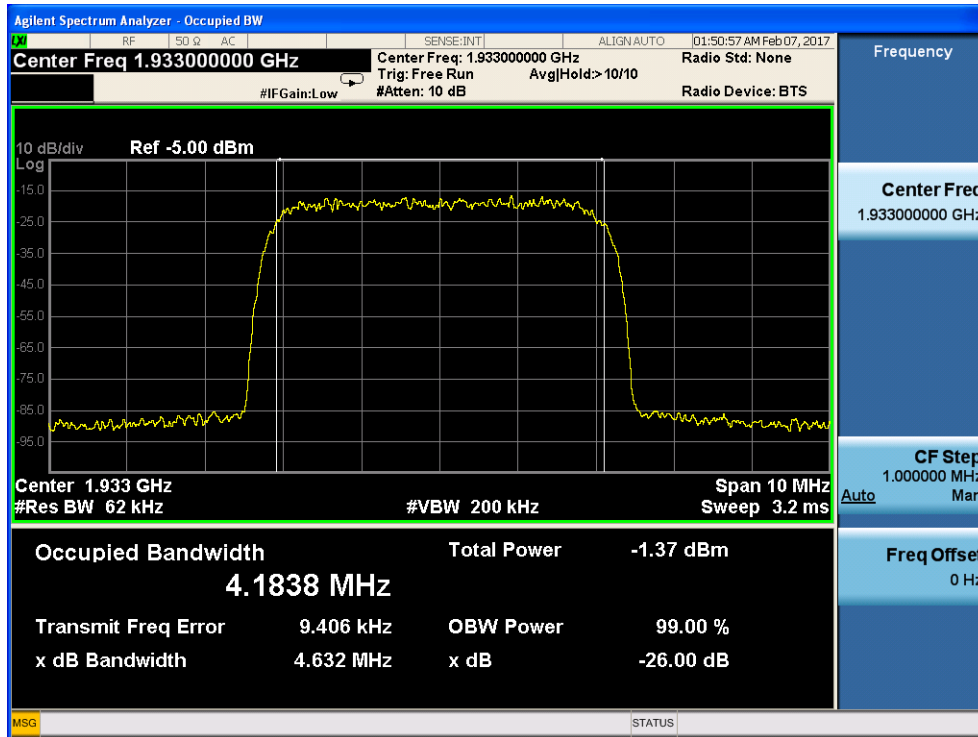

3.3.2 lowest frequency-- Output

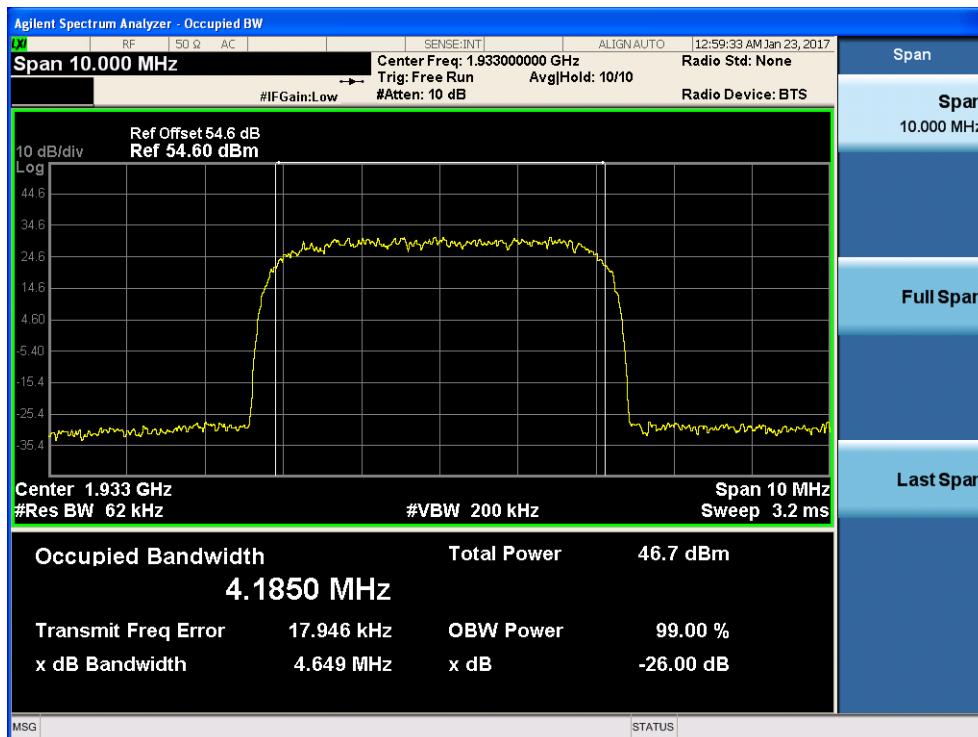

3.3.3 middle frequency-- Input

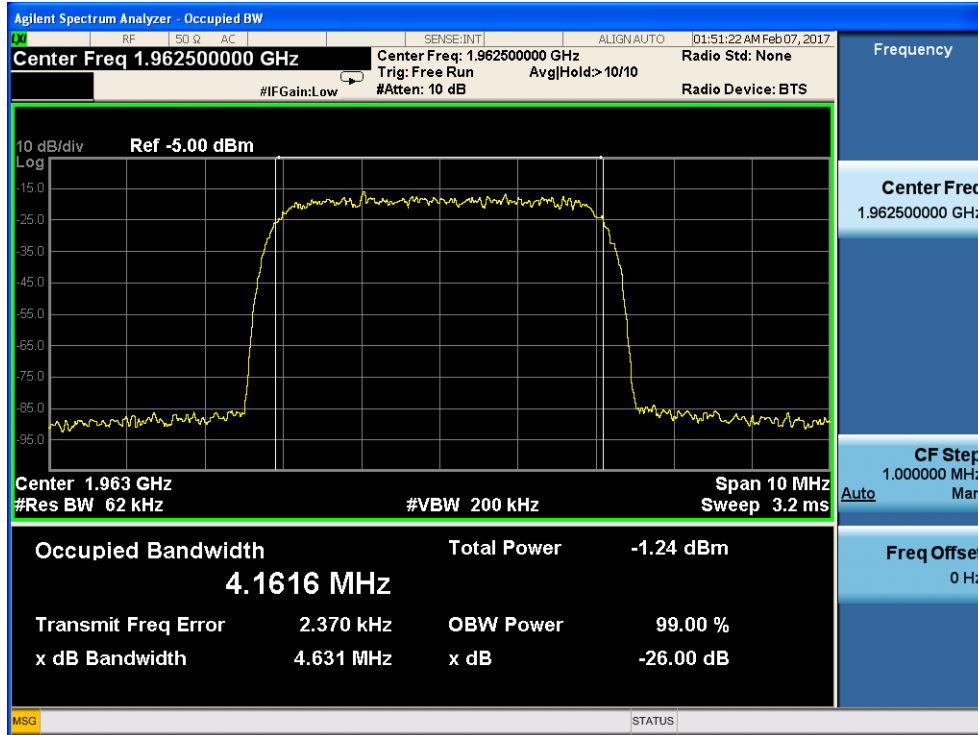

3.3.4 middle frequency-- Output

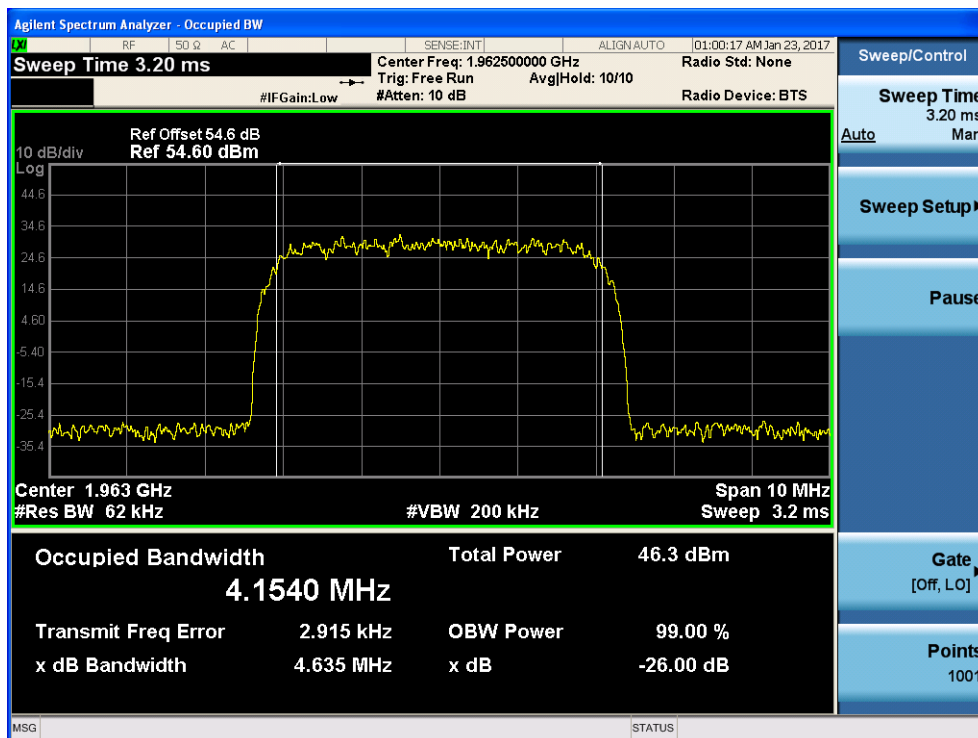



3.3.5 highest frequency—Input

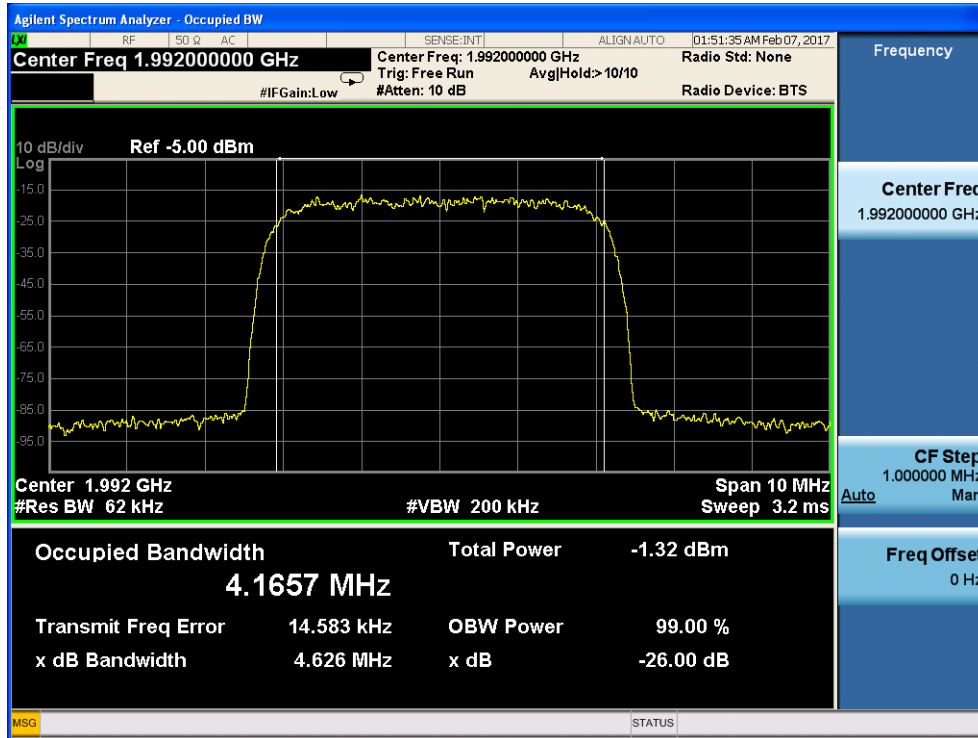

3.3.6 highest frequency--Output

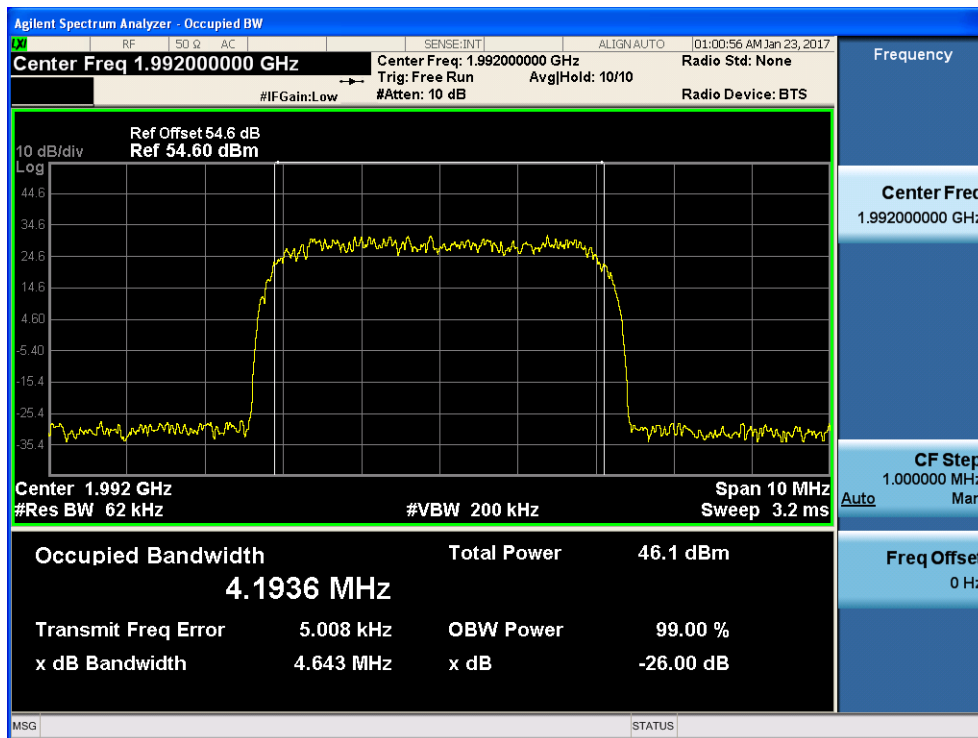



3.4 LTE Mode:

3.4.1 lowest frequency-- Input

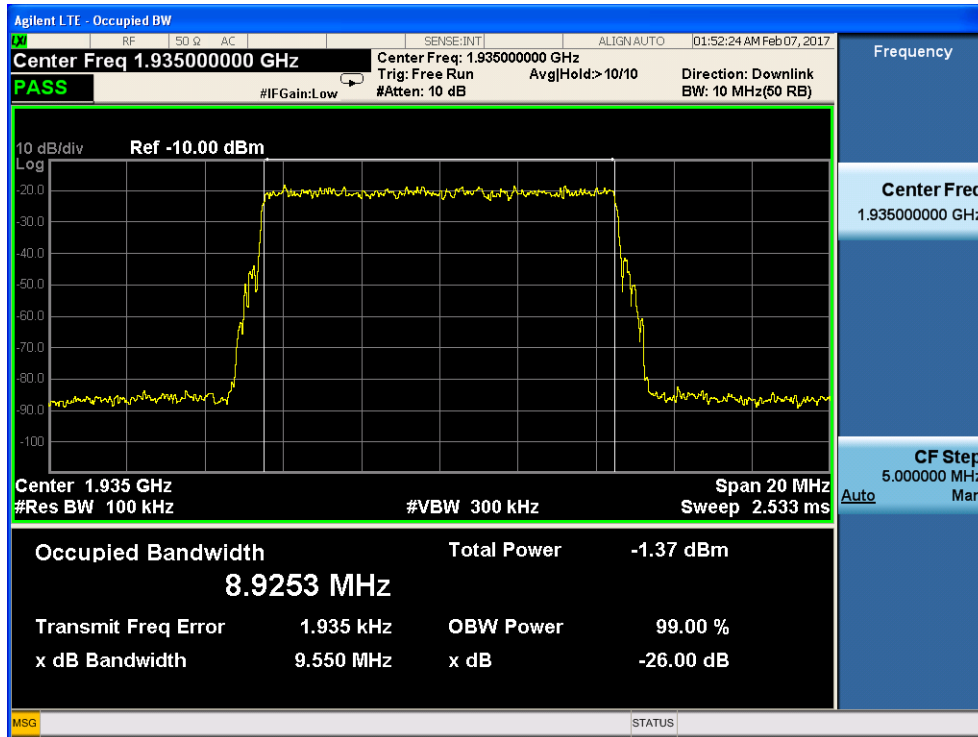

3.4.2 lowest frequency-- Output

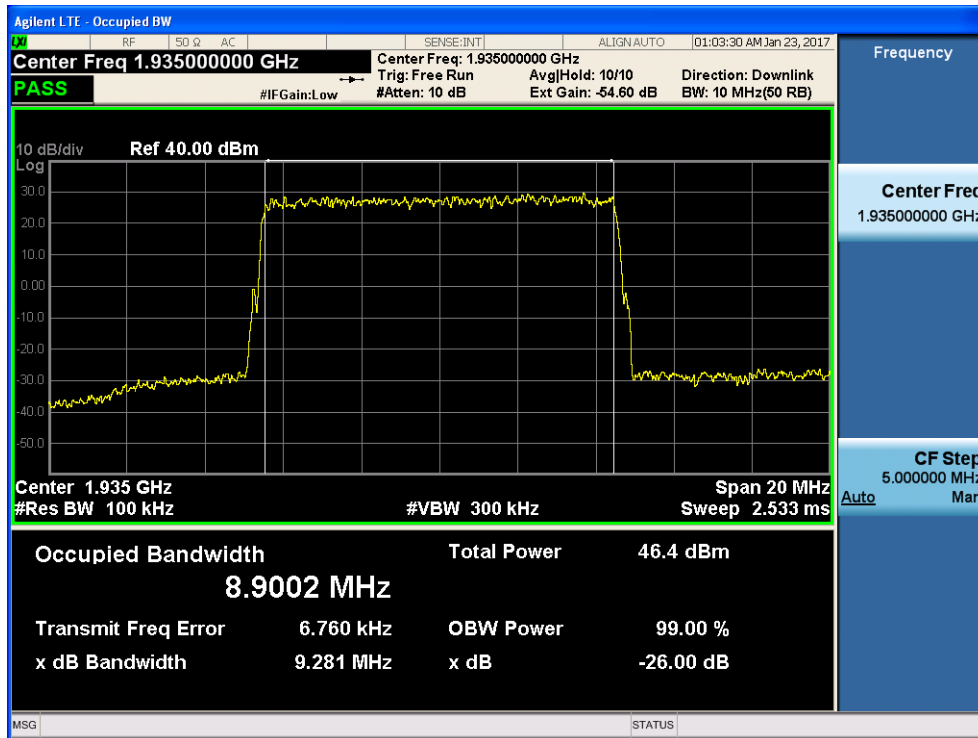

3.4.3 middle frequency-- Input

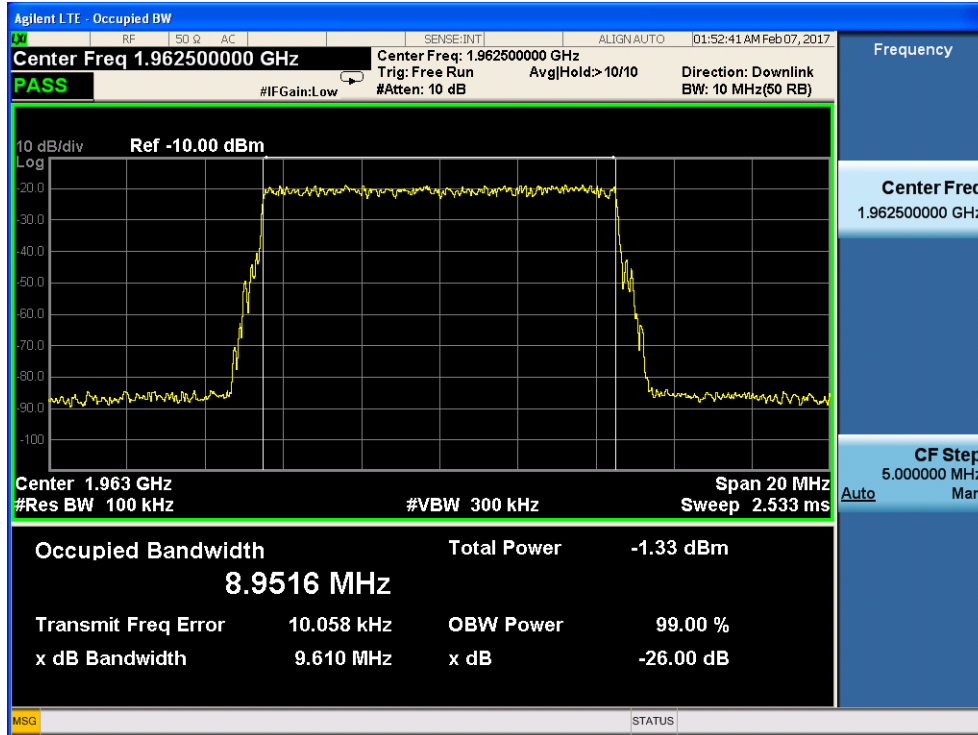

3.4.4 middle frequency-- Output

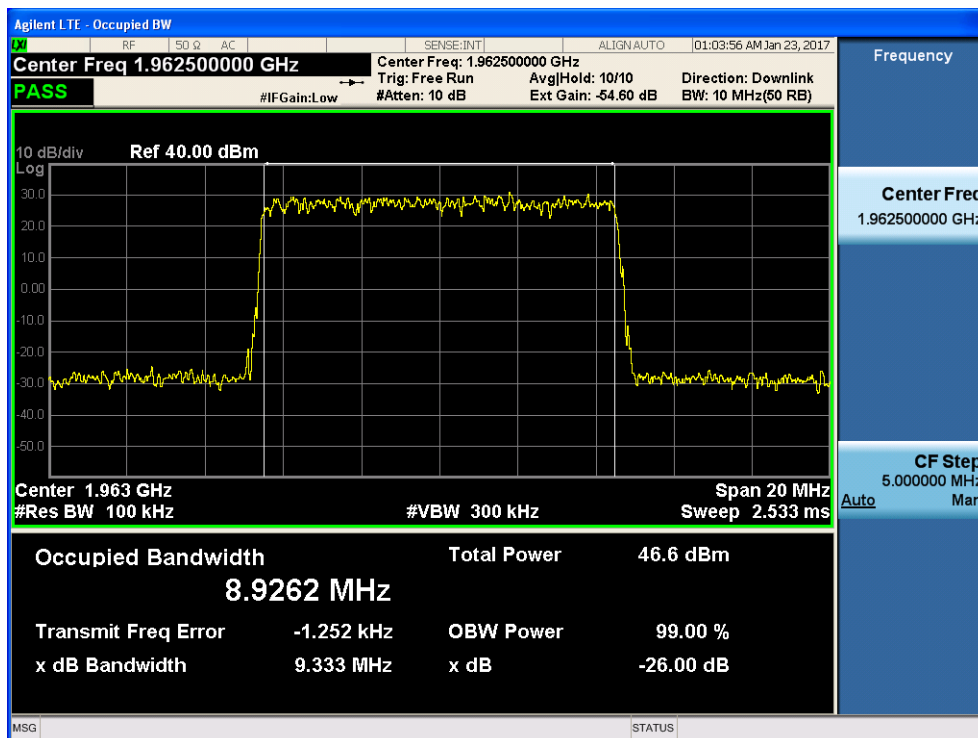

### 3.4.5 highest frequency—Input

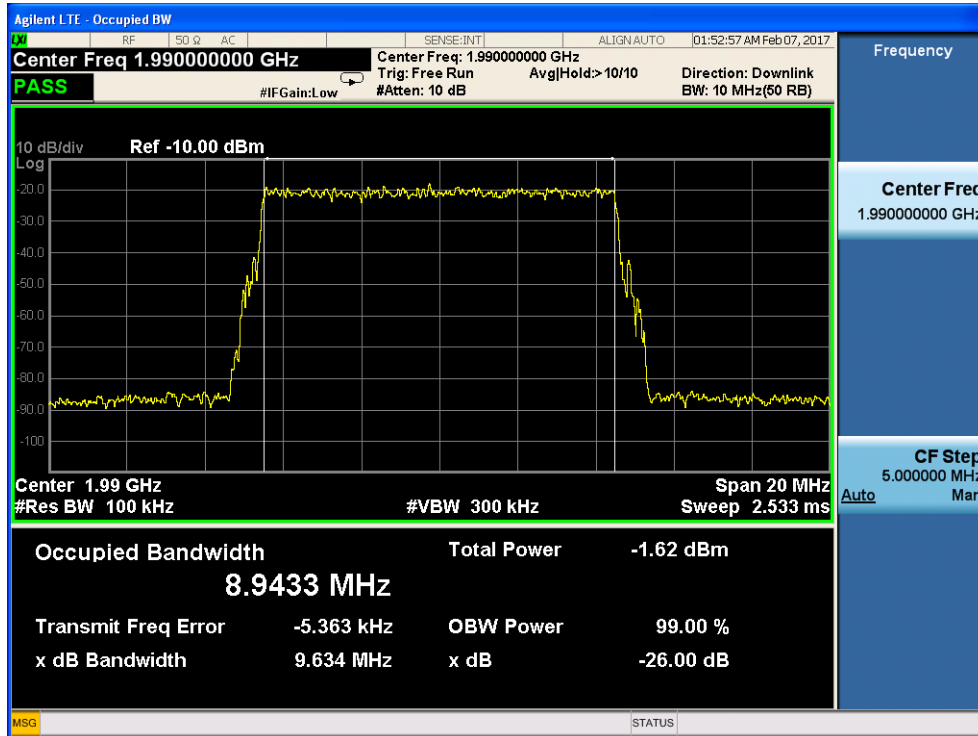

### 3.4.6 highest frequency--Output

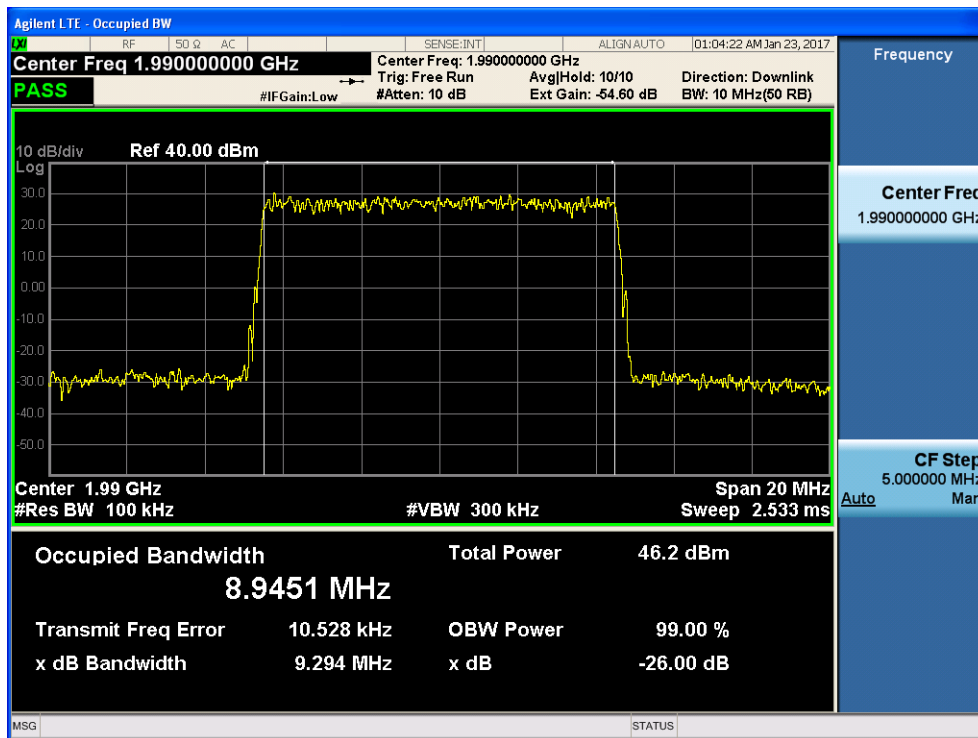

4. Downlink: 2110MHz to 2180MHz(CDMA,WCDMA,LTE)

4.1 CDMA Mode:

4.1.1 lowest frequency-- Input

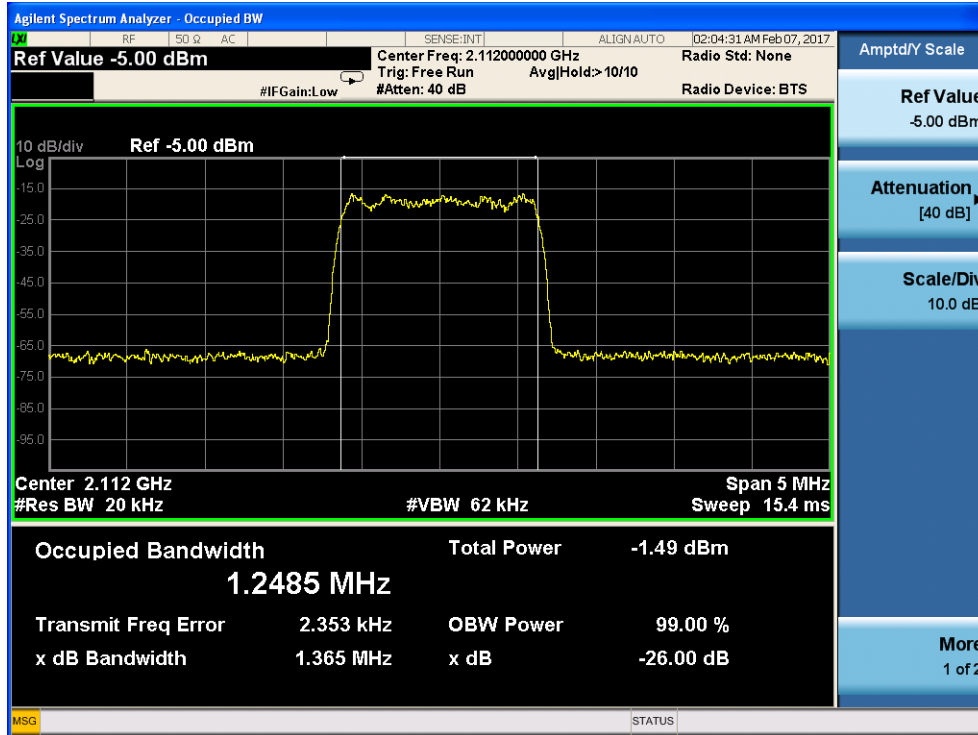

4.1.2 lowest frequency-- Output

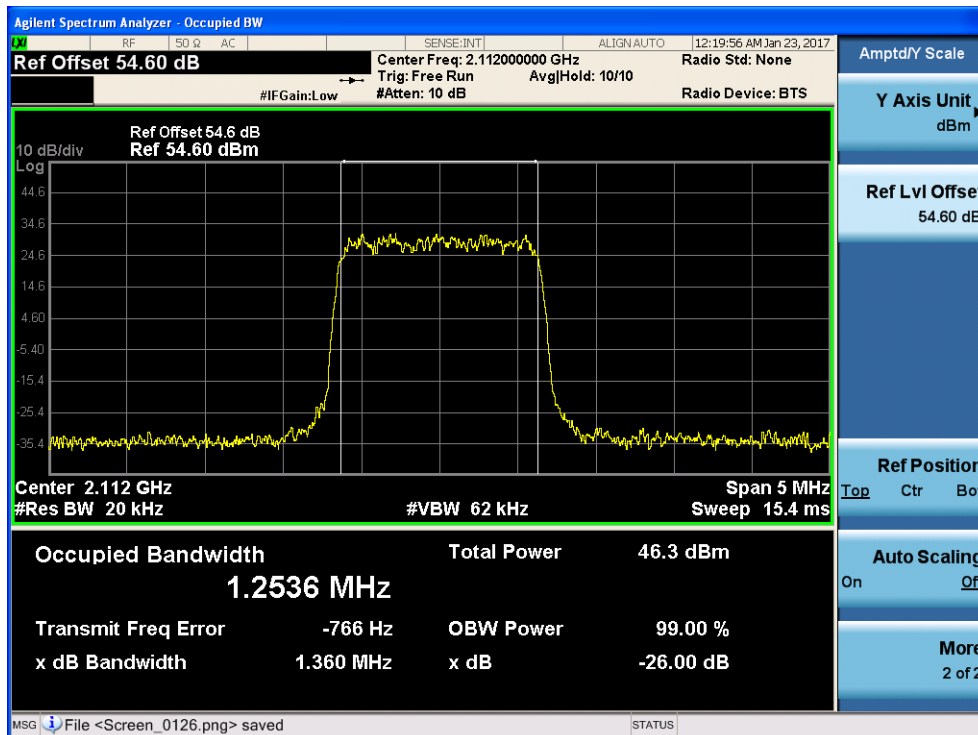

4.1.3 middle frequency-- Input

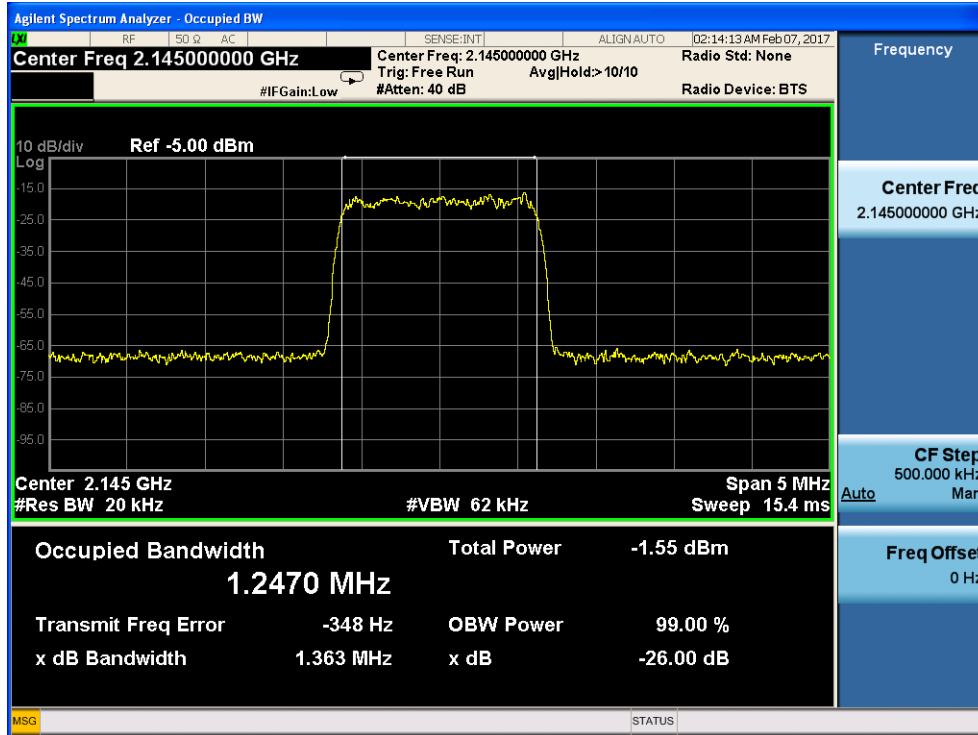

4.1.4 middle frequency-- Output

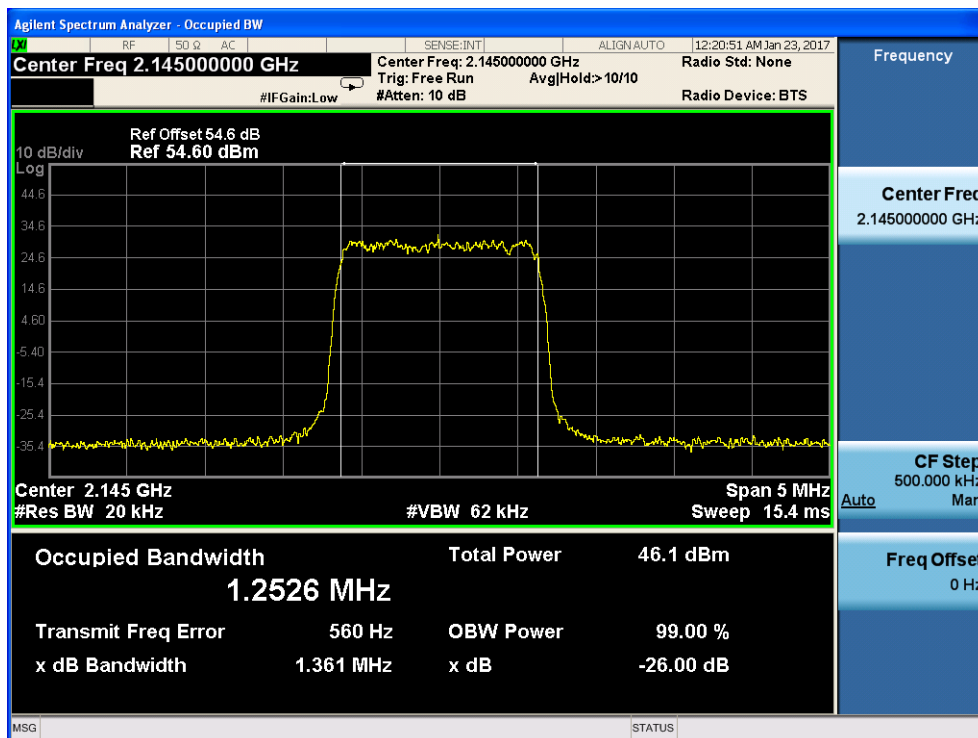



4.1.5 highest frequency—Input

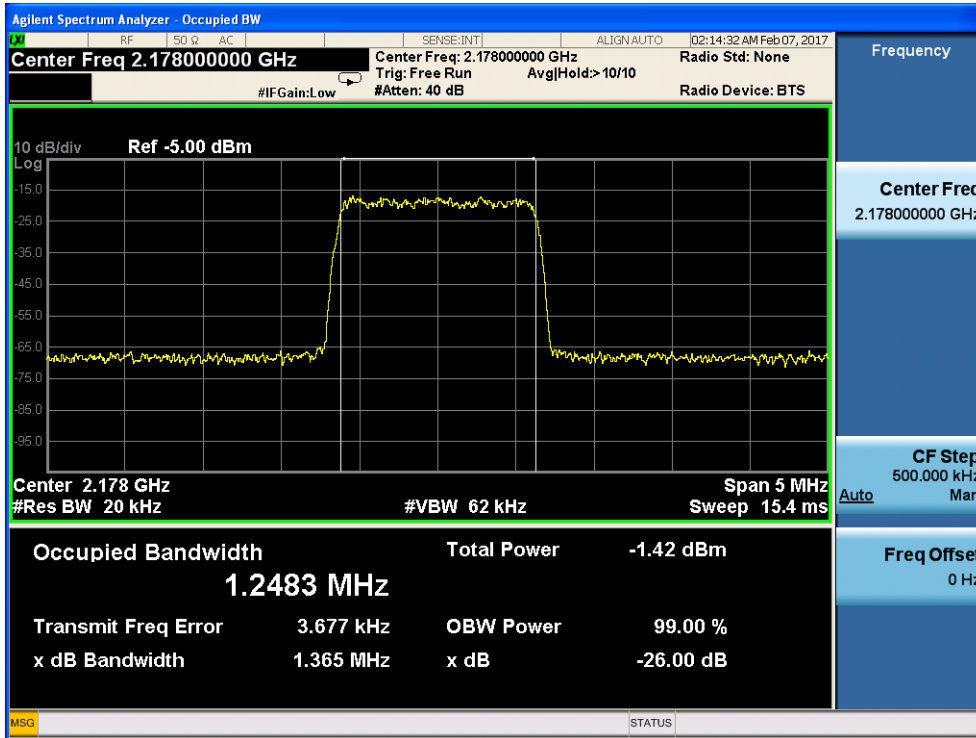

4.1.6 highest frequency--Output

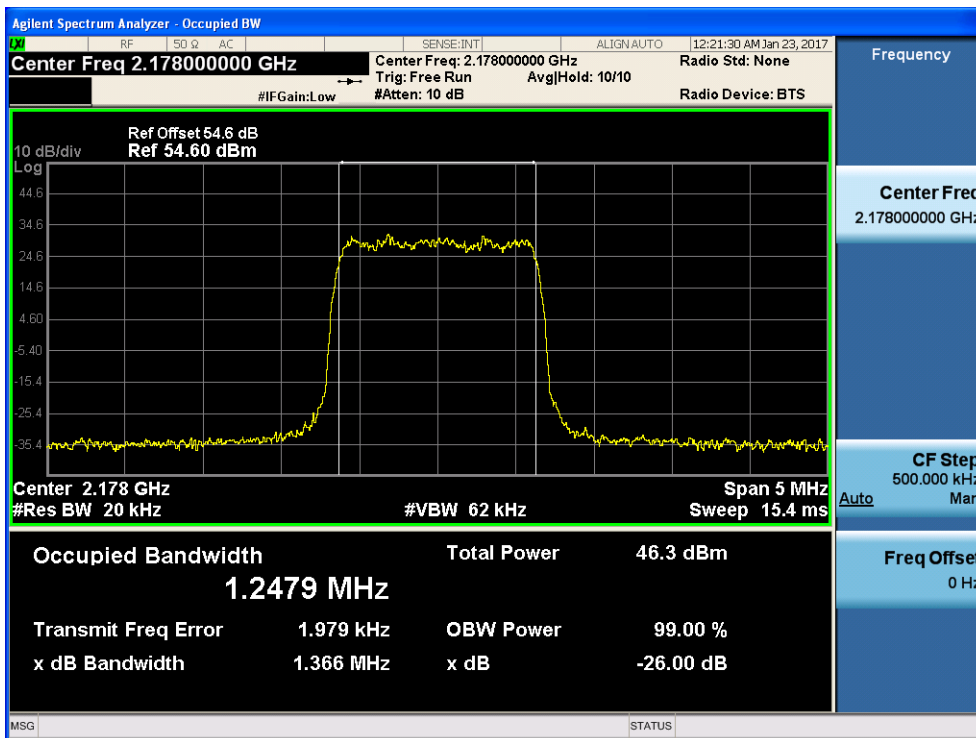

4.2 WCDMA Mode:

4.2.1 lowest frequency– Input

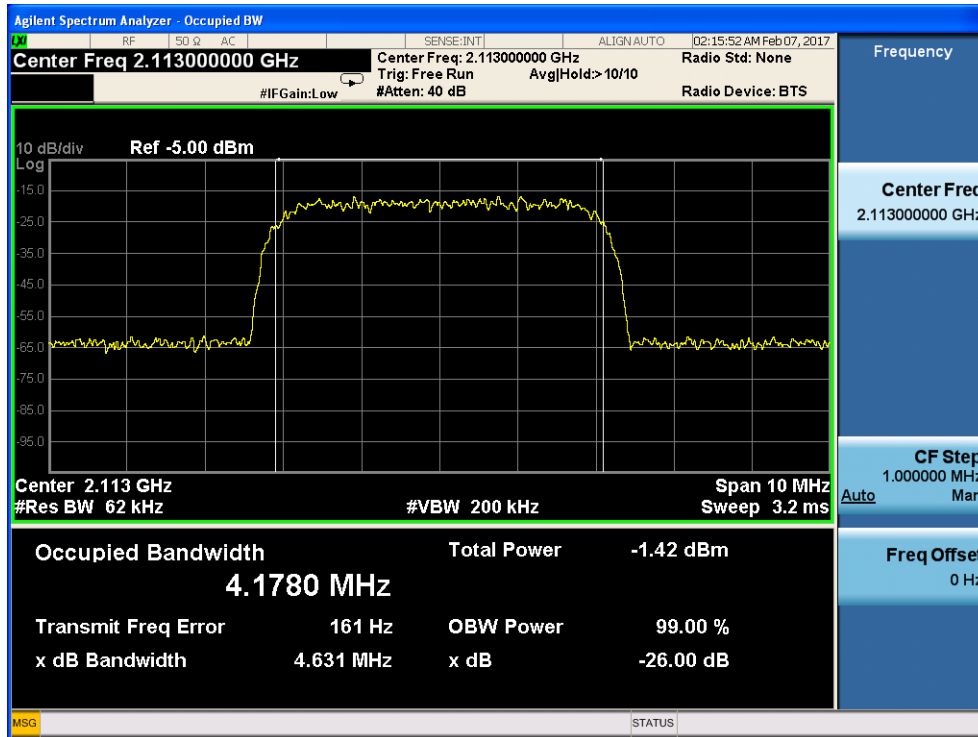

4.2.2 lowest frequency-- Output

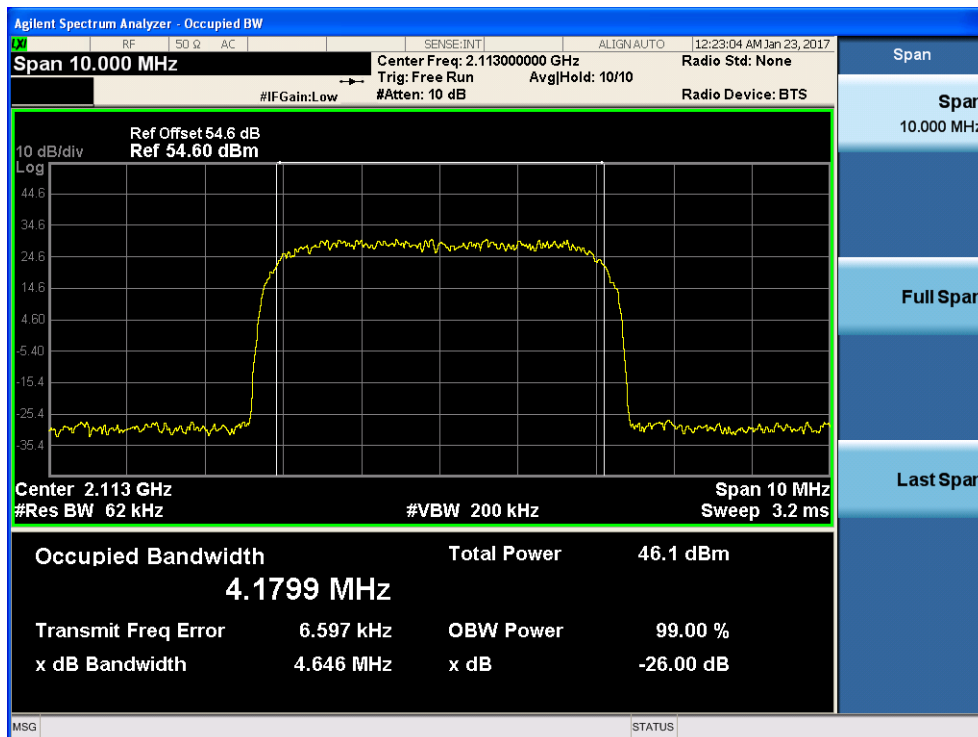

4.2.3 middle frequency-- Input

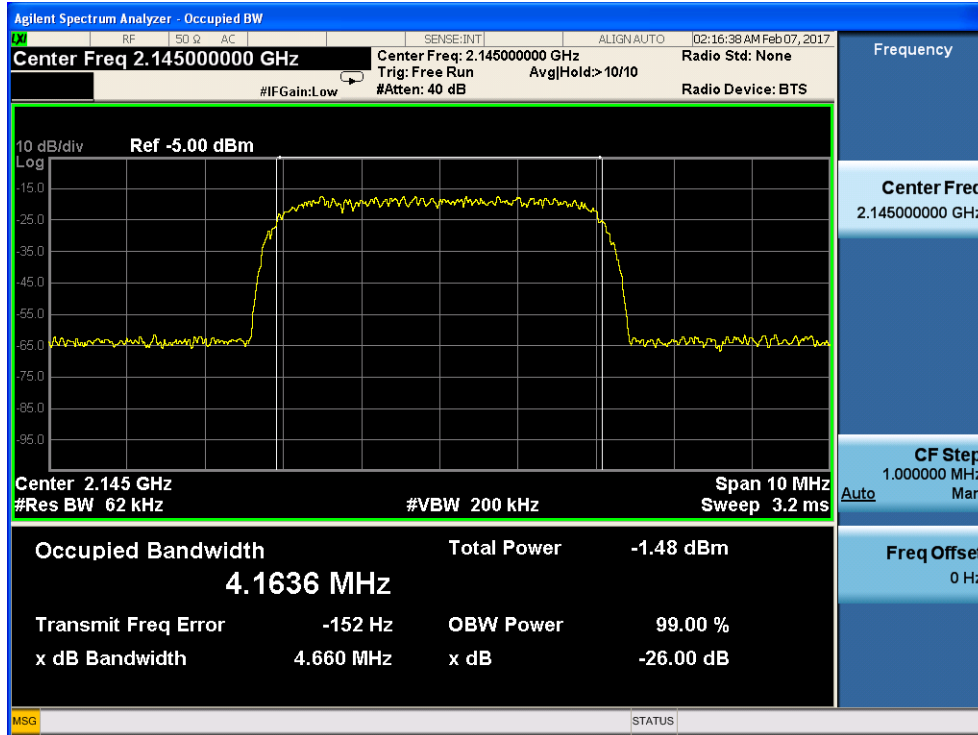

4.2.4 middle frequency-- Output

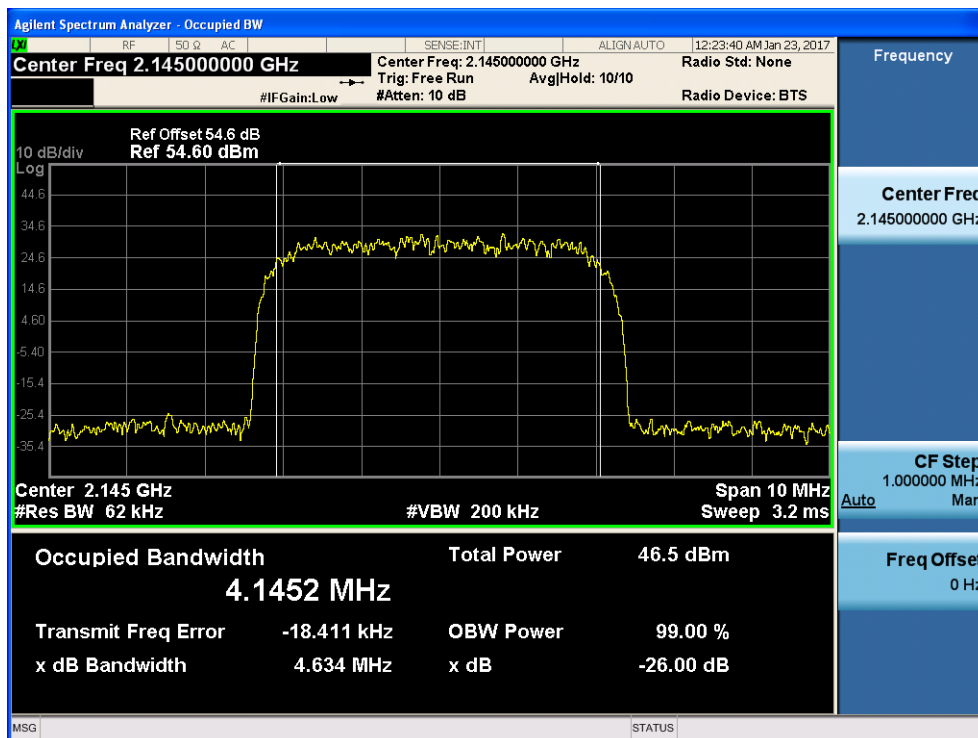



4.2.5 highest frequency—Input

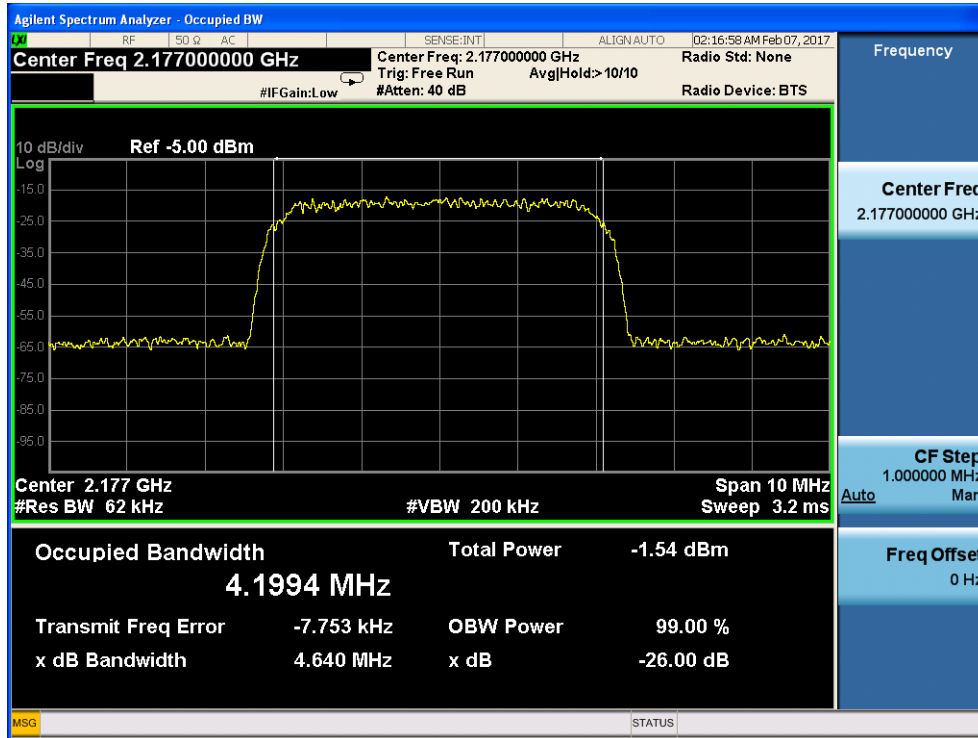

4.2.6 highest frequency--Output

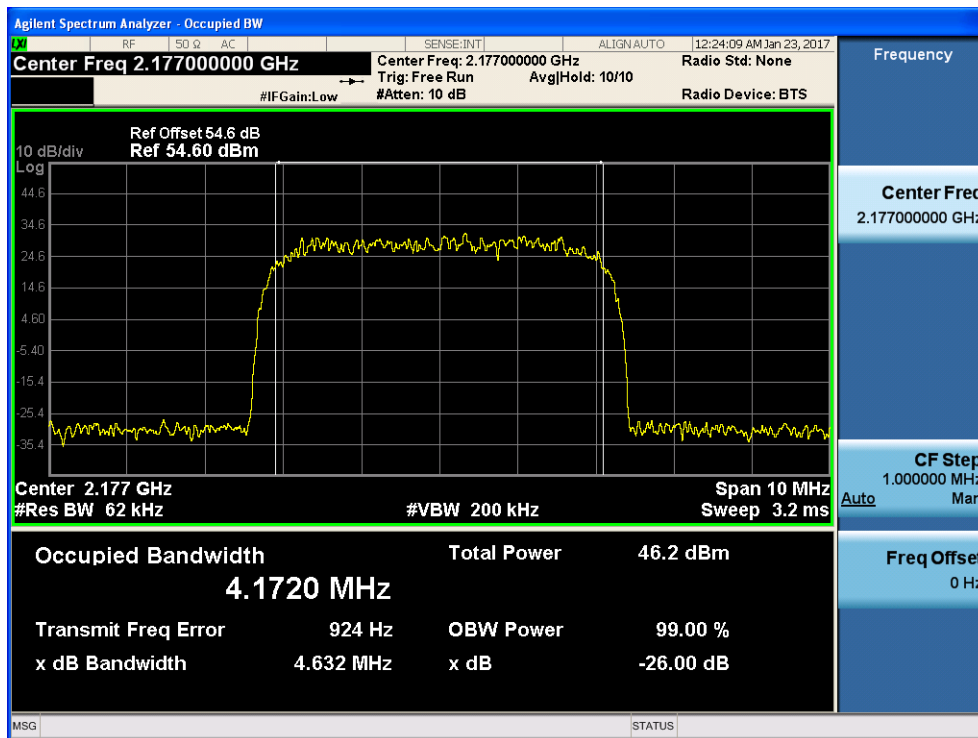

4.3 LTE Mode:

4.3.1 lowest frequency-- Input

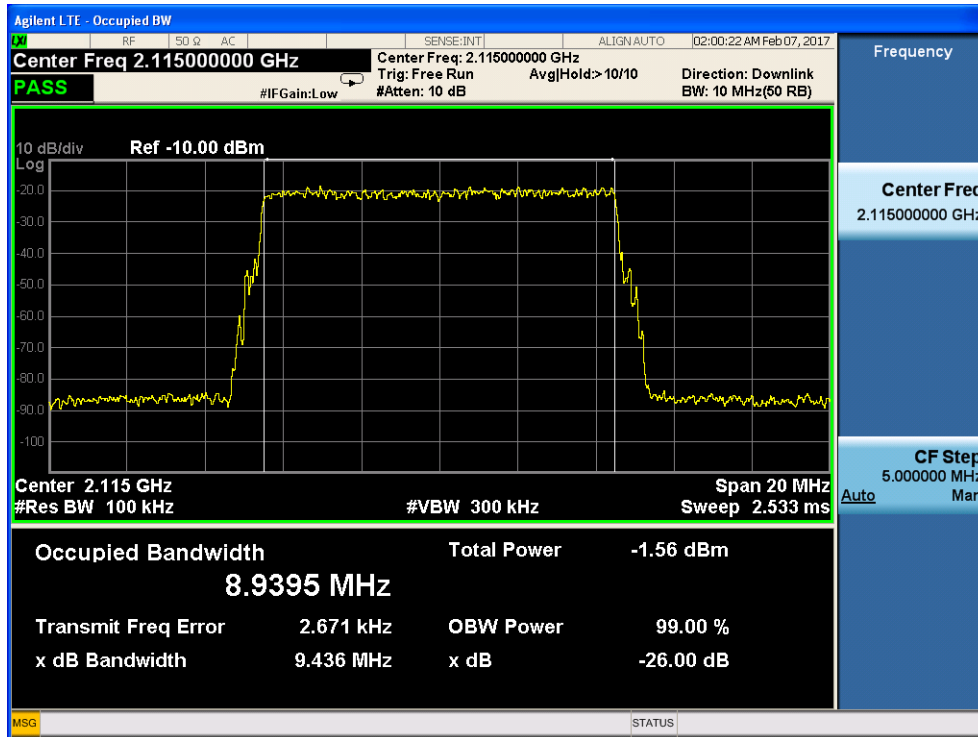

4.3.2 lowest frequency-- Output

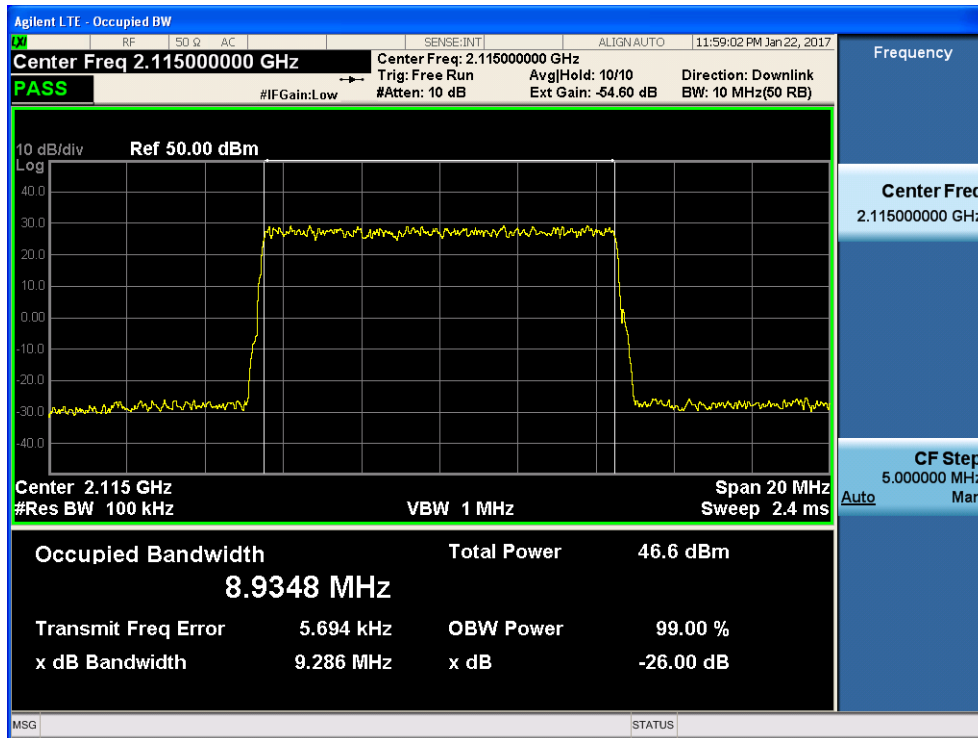

4.3.3 middle frequency-- Input

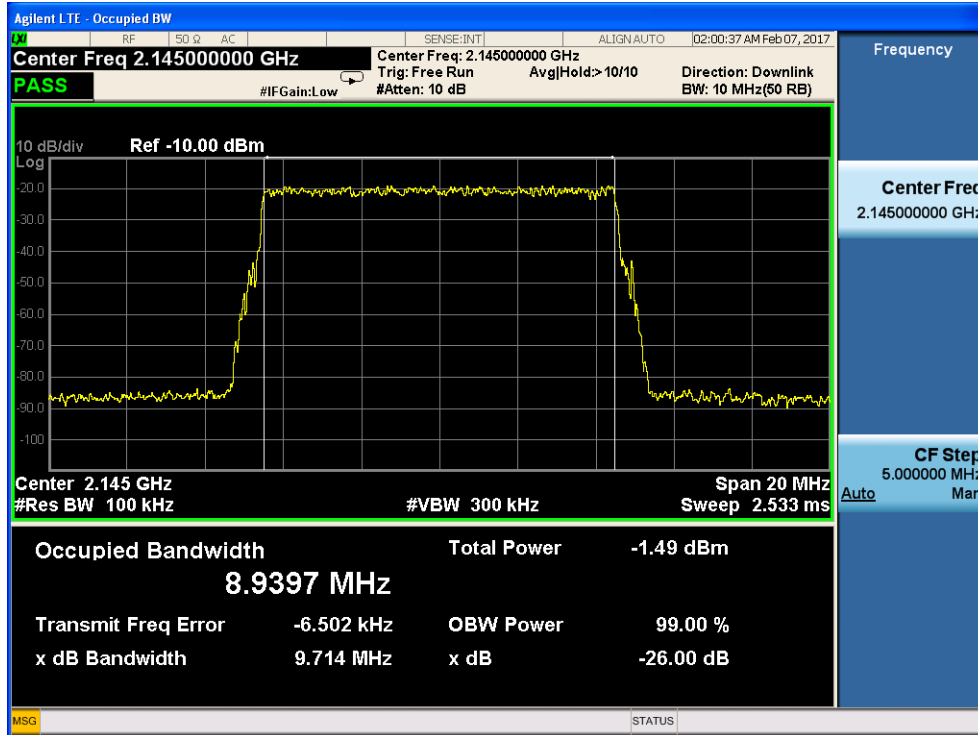

4.3.4 middle frequency-- Output

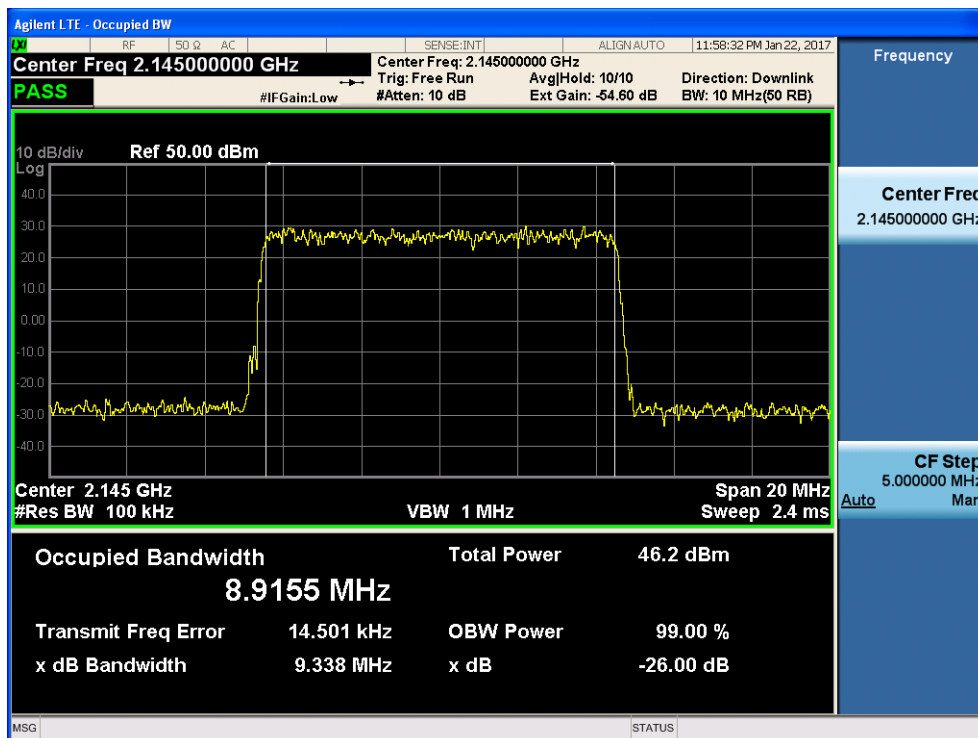

### 4.3.5 highest frequency—Input

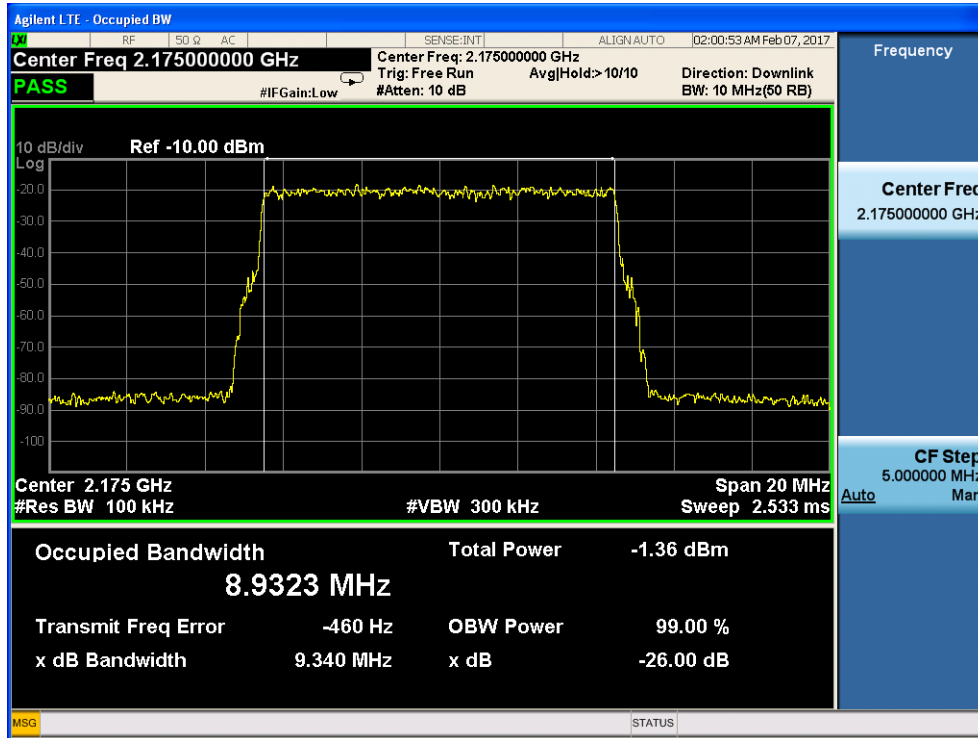

### 4.3.6 highest frequency--Output

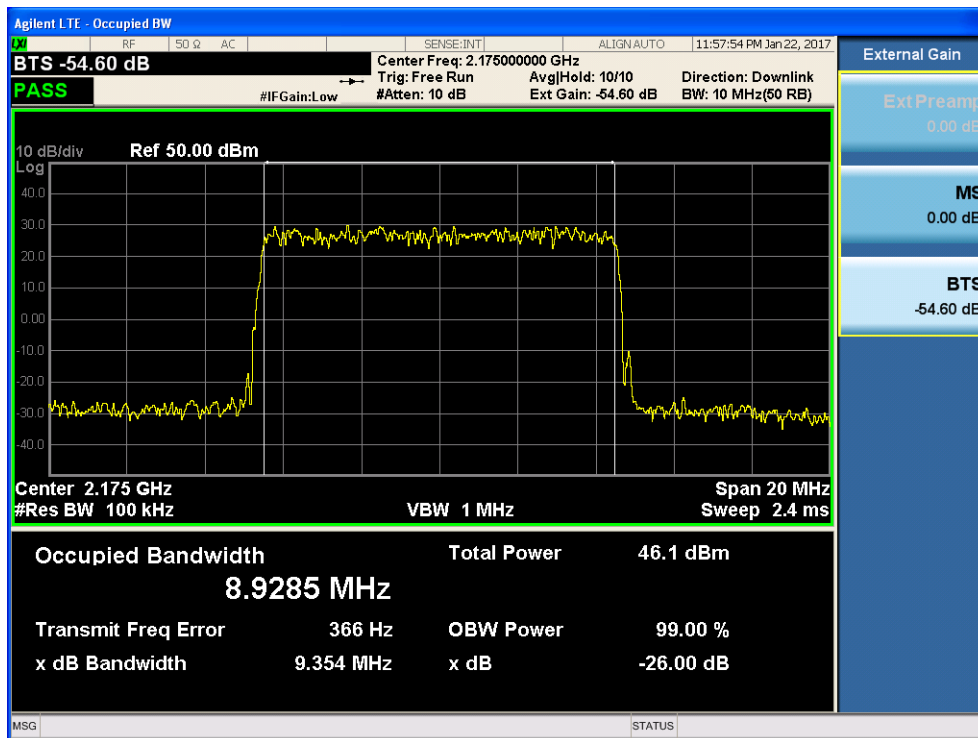

### 7.2.6 Out of Band Rejection

Test Date: 2017-01-22 and 2017-02-08

Test Requirement: KDB935210 D02;2-11-04/EAB/RF  
 Test for rejection of out of band signals. Filter freq. response plots are acceptable.

Test Method: KDB935210 D02;2-11-04/EAB/RF

EUT Operation:  
 Status: Drive the EUT to maximum output power. .  
 Conditions: Normal conditions  
 Application: Cellular Band RF output ports

Test Configuration:

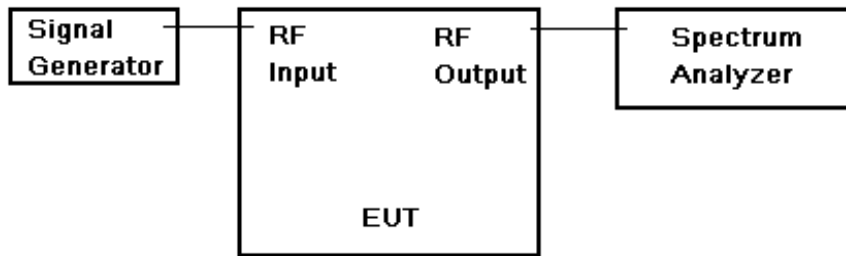

Fig.4. Out of Band rejection test configuration

- Test Procedure:
1. Connect the equipment as illustrated;
  2. Test the background noise level with all the test facilities;
  3. Keep one transmitting path, all other connectors shall be connected by normal power or RF leads;
  4. Select the attenuator to avoid the test receiver or spectrum analyzer being destroyed;
  5. Keep the EUT continuously transmitting in max power;
  6. Signal generator sweep from the frequency more lower than the product frequency to the frequency more higher than it, find the product band filter characteristic;
    - CW signal rather than typical signal is acceptable (for FM).
    - Multiple band filter will need test each other.



7.2.6.1 Measurement Record:

1. Test for Downlink: 728MHz to 757MHz

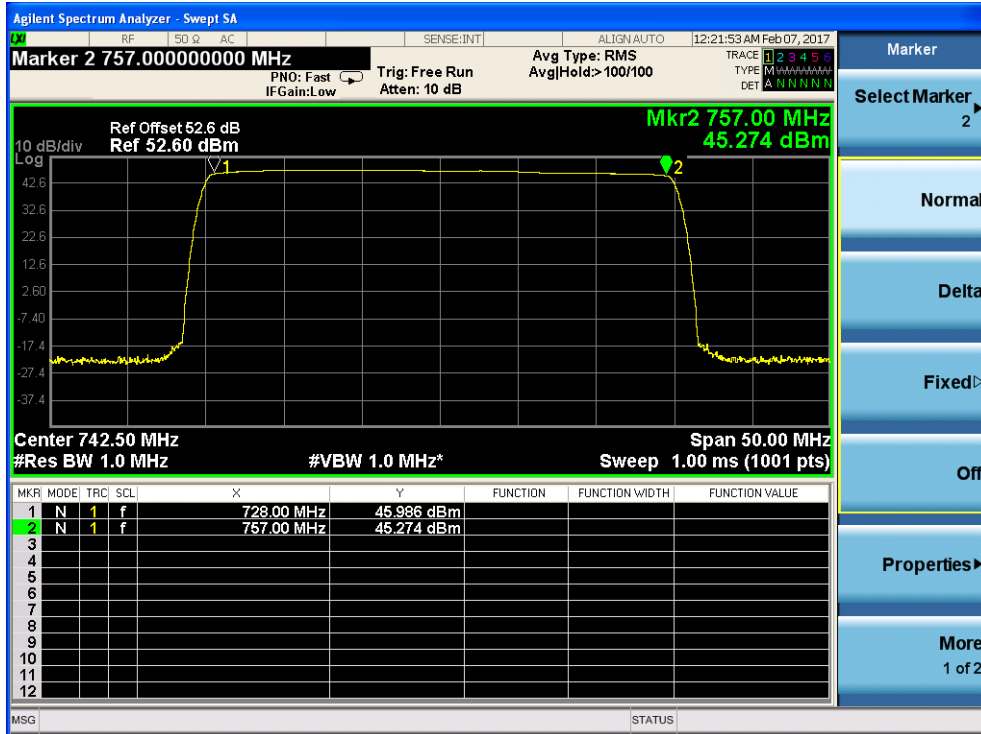

2. Test for Downlink: 862MHz to 869MHz

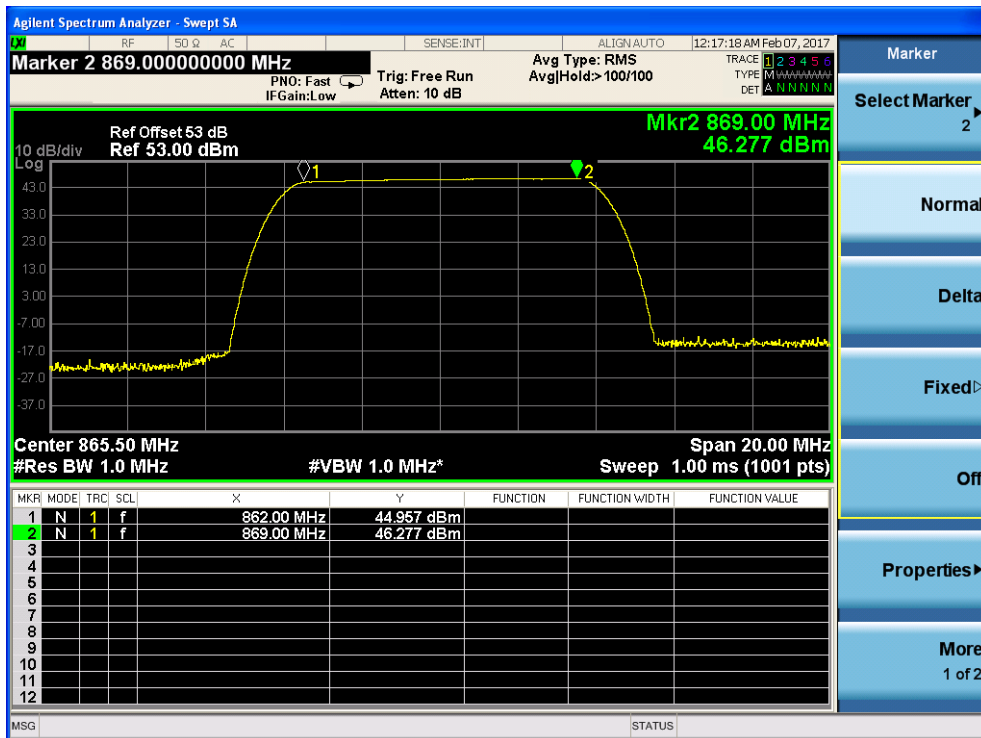

3. Test for Downlink: 869MHz to 894MHz

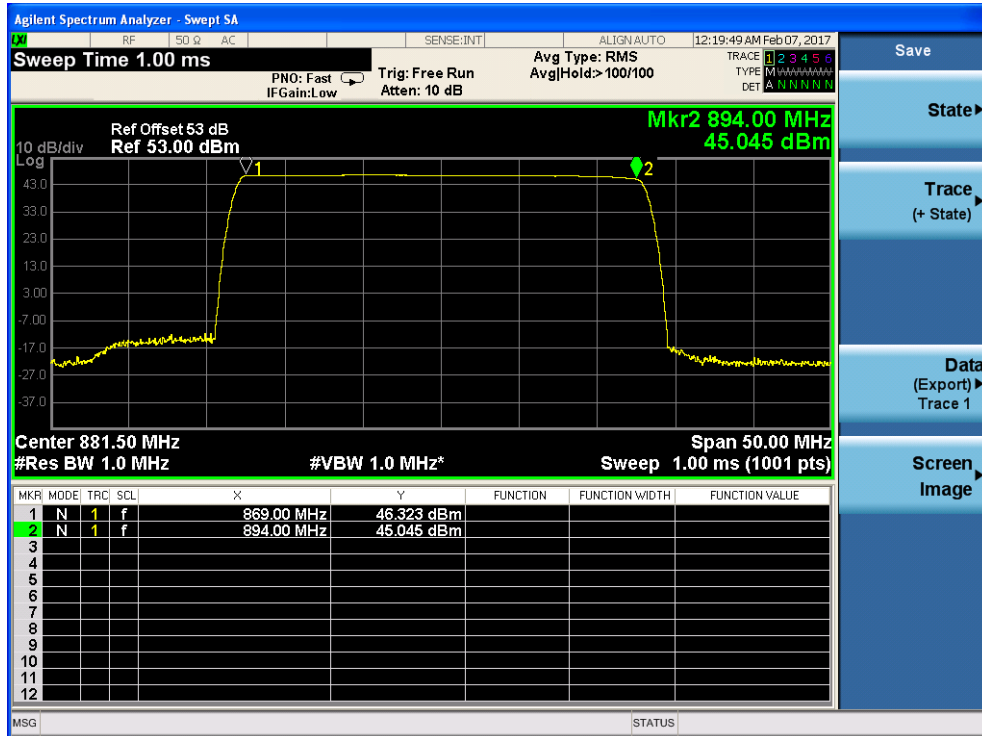

4. Test for Downlink: 1930MHz to 1995MHz

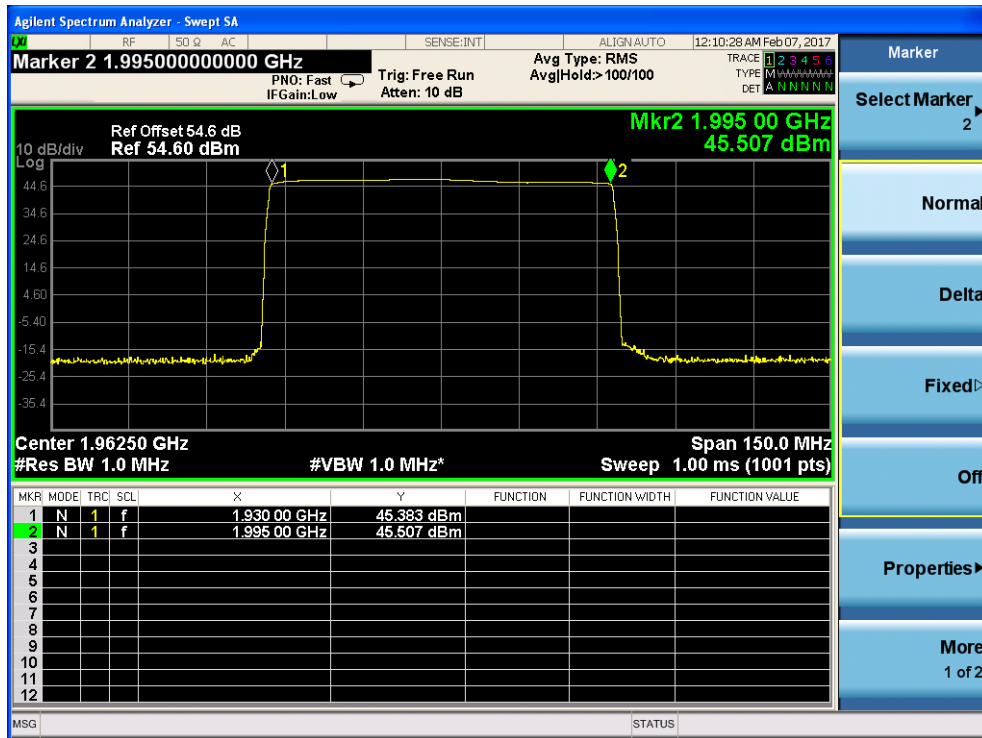



5. Test for Downlink:2110MHz to 2180MHz

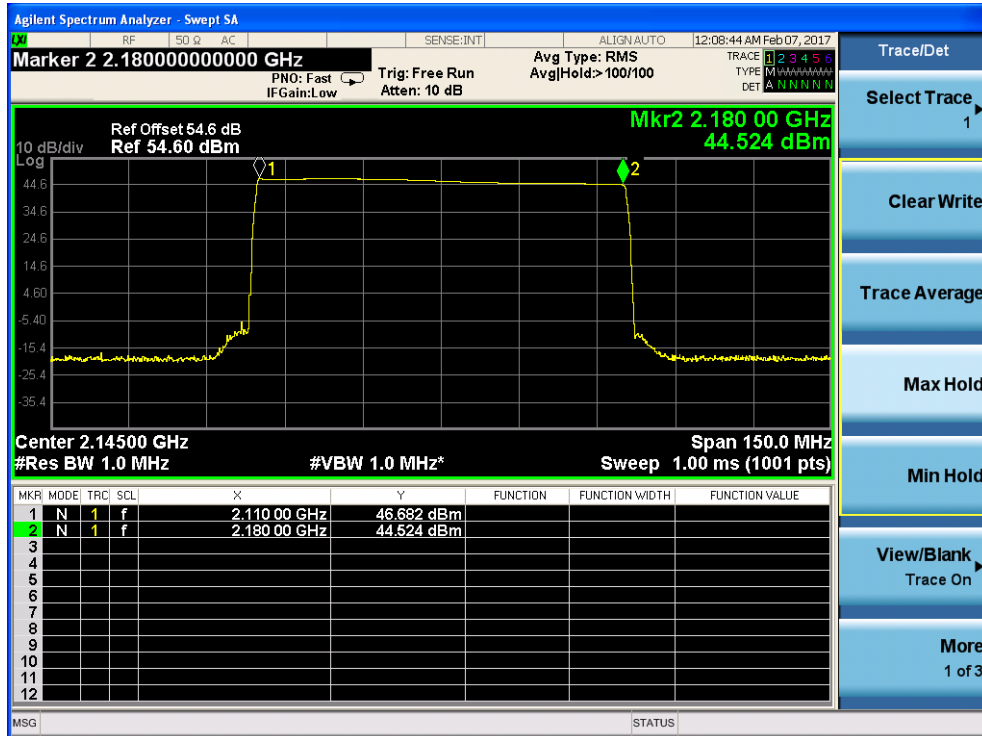





## 7.2.7 Frequency Stability

- Test Date: 2016-10-08 to 2017-01-22 and 2017-02-08
- Test Requirement: FCC part 90.213 & FCC part 22.355 & FCC part 24.235 & FCC part 27.54  
The frequency stability shall be sufficient to ensure that the fundamental emissions stay within the authorized bands of operation.
- Test Method: FCC part 2.1055
- EUT Operation:
- Status: Drive the EUT to maximum output power.
  - Conditions: Temperature conditions, voltage conditions
  - Application: Cellular Band RF output ports
- Test Procedure:
1. Temperature conditions:
    - a) The RF output port of the EUT was connected to Frequency Meter;
    - b) Set the working Frequency in the middle channel;
    - c) record the 20°C and nominal voltage frequency value as reference point;
    - d) vary the temperature from -40°C to 50°C with step 10°C
    - e) when reach a temperature point, keep the temperature balance at least 1 hour to make the product working in this status;
    - f) read the frequency at the relative temperature.
  2. Voltage conditions:
    - a) record the 20°C and nominal voltage frequency value as reference point;
    - b) vary the voltage from -15% nominal voltage to +15% voltage;
    - c) read the frequency at the relative voltage.

**7.2.7.1 Measurement Record:**

**1) Frequency Stability vs temperature:**

1.1) Test for Downlink: 728~757MHz (middle channel 742.5MHz)

Temperature(°C)	Frequency(MHz)	Tolerance(ppm)
50	742.5000025	0.000404040
40	742.5000024	0.000269360
30	742.5000028	0.000808080
20	742.5000022	Reference
10	742.5000023	0.000134680
0	742.5000026	0.000538721
-10	742.5000023	0.000134680
-20	742.5000029	0.000942761
-30	742.5000027	0.000673401
-40	742.5000024	0.000269360

1.2) Test for Downlink: 862~869MHz (middle channel 865.5MHz)

Temperature(°C)	Frequency(MHz)	Tolerance(ppm)
50	865.5000027	0.000577770
40	865.5000026	0.00034662
30	865.5000032	0.00103986
20	865.5000023	Reference
10	865.5000026	0.00034662
0	865.5000029	-0.00069324
-10	865.5000023	0
-20	865.5000019	-0.00046216
-30	865.5000021	-0.00023108
-40	865.5000018	0.000577770

1.3) Test for Downlink: 869~894MHz (middle channel 881.5MHz)

Temperature(°C)	Frequency(MHz)	Tolerance(ppm)
50	881.5000027	0.000567214
40	881.5000026	0.000680657
30	881.5000030	0.001020987
20	881.5000021	Reference
10	881.5000023	0.000226886
0	881.5000029	0.000680658
-10	881.5000025	0.000453772
-20	881.5000018	-0.000340329
-30	881.5000023	0
-40	881.5000030	0.001020987

1.3) Test for Downlink: 1930~1995MHz (middle channel 1962.5MHz)

Temperature(°C)	Frequency(MHz)	Tolerance(ppm)
50	1962.500025	0.000203821
40	1962.500023	-0.000101911
30	1962.500026	0.000254777
20	1962.500021	Reference
10	1962.500027	0.000305732
0	1962.500026	0.000254777
-10	1962.500029	0.000407643
-20	1962.500028	0.000356688
-30	1962.500021	0
-40	1962.500022	0.000050955

1.4) Test for Downlink: 2110~2180MHz (middle channel 2147.5MHz)

Temperature(°C)	Frequency(MHz)	Tolerance(ppm)
50	2147.500021	0.000187573
40	2147.500026	0.000046893
30	2147.500030	0.000234467
20	2147.500025	Reference
10	2147.500024	-0.000046893
0	2147.500023	-0.000093787
-10	2147.500027	0.000093787
-20	2147.500030	0.000234467
-30	2147.500029	-0.000093787
-40	2147.500022	0.000140680

**2) Frequency Stability vs voltage:**

2.1) For AC supplied:

2.1.1) Test for Downlink:728~757MHz (middle channel 742.5MHz)

Voltage(V AC)	Frequency(MHz)	Tolerance(ppm)
102 (120*0.85)	742.500023	0.00040404
120	742.500020	Reference
138 (120*1.15)	742.500027	0.00094276

2.1.2) Test for Downlink: 862~869MHz (middle channel 865.5MHz)

Voltage(V AC)	Frequency(MHz)	Tolerance(ppm)
102 (120*0.85)	865.500026	-0.00034662
120	865.500023	Reference
138 (120*1.15)	865.500025	0.00023108



2.1.3) Test for Downlink: 869~894MHz (middle channel 881.5MHz)

Voltage(V AC)	Frequency(MHz)	Tolerance(ppm)
102 (120*0.85)	881.5000024	0.00022689
120	881.5000026	Reference
138 (120*1.15)	881.5000027	0.00011344

2.1.4) Test for Downlink: 1930~1995MHz (middle channel 1962.5MHz)

Voltage(V AC)	Frequency(MHz)	Tolerance(ppm)
102 (120*0.85)	1962.5000022	0.00005096
120	1962.5000023	Reference
138 (120*1.15)	1962.5000028	0.00025477

2.1.5) Test for Downlink: 2110~2180MHz (middle channel 2147.5MHz)

Voltage(V AC)	Frequency(MHz)	Tolerance(ppm)
102 (120*0.85)	2147.5000025	0.0000187573
120	2147.5000021	Reference
138 (120*1.15)	2147.5000027	0.000281360

**2.2) For DC supplied:**

2.2.1) Test for Downlink:728~757MHz (middle channel 742.5MHz)

Voltage(V DC)	Frequency(MHz)	Tolerance(ppm)
-40.8 (-48.0*0.85)	742.5000017	0.00067340
-48.0	742.5000022	Reference
-55.2 (-48.0*1.15)	742.5000026	-0.00053872

2.2.2) Test for Downlink: 862~869MHz (middle channel 865.5MHz)

Voltage(V DC)	Frequency(MHz)	Tolerance(ppm)
-40.8 (-48.0*0.85)	865.5000022	-0.00462427
-48.0	865.5000026	Reference
-55.2 (-48.0*1.15)	865.5000021	-0.00057770

2.2.3) Test for Downlink: 869~894MHz (middle channel 881.5MHz)

Voltage(V DC)	Frequency(MHz)	Tolerance(ppm)
-40.8 (-48.0*0.85)	881.5000027	0.00045377
-48.0	881.5000023	Reference
-55.2 (-48.0*1.15)	881.5000026	-0.00034033

2.2.4) Test for Downlink: 1930~1995MHz (middle channel 1962.5MHz)

Voltage(V DC)	Frequency(MHz)	Tolerance(ppm)
-40.8 (-48.0*0.85)	1962.5000022	-0.00207922
-48.0	1962.5000026	Reference
-55.2 (-48.0*1.15)	1962.5000028	0.00010191

2.2.5) Test for Downlink: 2110~2180MHz (middle channel 2147.5MHz)

Voltage(V DC)	Frequency(MHz)	Tolerance(ppm)
-40.8 (-48.0*0.85)	2147.5000025	0.00004689
-48.0	2147.5000024	Reference
-55.2 (-48.0*1.15)	2147.5000021	0.00014068

**--The End of Report--**