

Comflex NG User manual

1. System Introduction

1.1 Introduction

Comba Analog DAS Solution is an industrial-leading in-building distributed antenna solution for enterprise and consumer application, supporting the wide application range of cellular generations: 4G and 5G.

This solution is based on analog DAS technology with wide-band and multi-band distribution architecture, flexible off-air or wired connection mode, enabling efficient utilization of signal links. It is designed to support multi-band, multi-technology, and multi-operator networks with flexible configuration and easy commissioning.

1.2 System Architecture

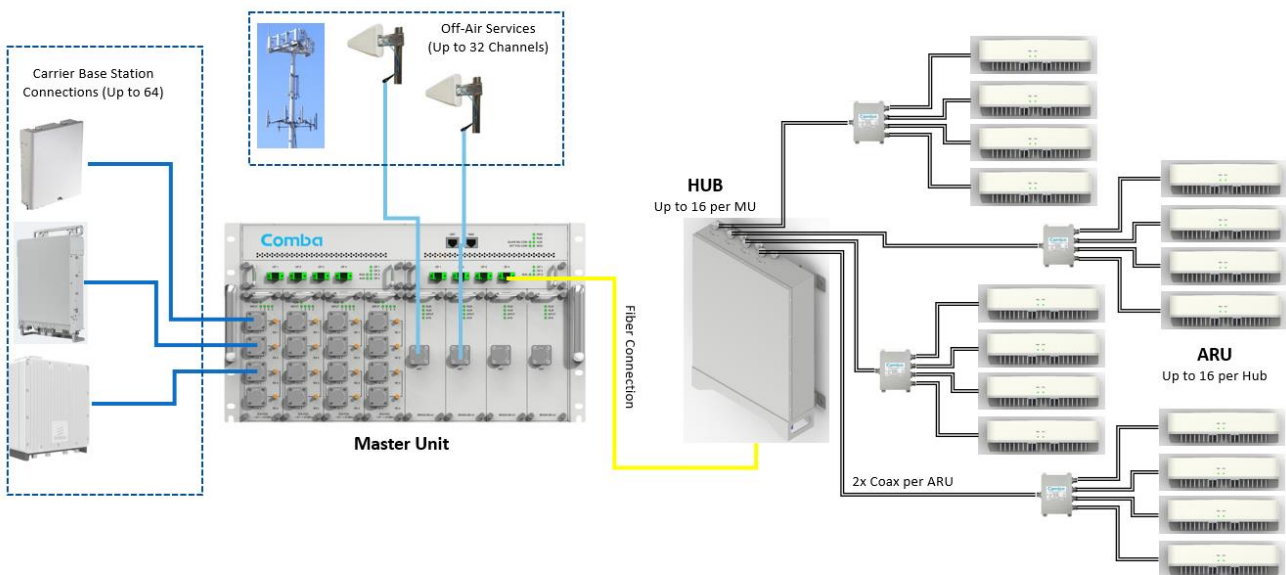

MU – Master Unit

Select dedicated radio signal, transmit to fiber signal and then transfer to fiber Hub. It can support two kinds connectivity to radio signal: off-air connection and wired connection with different module.

Fiber Hub

The Fiber Hub is the central Hub and Distribution element for the analog DAS system. The fiber hub interfaces between the MU and the active antenna unit, allowing it to receive the operators service signals in optical link, and to route signals to the active antenna unit.

Active Antenna Unit

The active antenna unit is a low-power remote antenna unit with 19~22 dBm per MIMO stream per band

1.3 System Function

1.3.1 System features

- 1) Supports up to 6T6R, 4G and 5G signals
- 2) Output power
 - 2.5GHz/3.5GHz: 22dBm
 - 700MHz/850MHz/1900MHz/EAWS: 19dBm
- 3) Network topology
 - MU + Fiber HUB + ARU: 1+16+256
 - MU can connect to ONE slave MU
 - MU can extend up to 16pcs fiber Hub
 - Fiber HUB can connect to 16pcs ARU
 - MU-HUB max fiber loss 8dB_o:
 - HUB-ARU max fiber loss distance 45dB
- 4) Power Supply
 - MU & HUB: AC 110V
 - ARU: DC 48V
- 5) Couple way
 - Off-air couple : MU - BDA Card
 - Wired couple: MU - POI card

1.3.2 Monitoring

- 1) Local monitor: local debug and commission
- 2) Remote control: Control the system in MU site
- 3) System upgrade: Software upgrade in MU
- 4) 4G/5G demodulation: Demodulate the cellular features: RSRP, SINR, PLMN

1.4 Specification

1.4.1 Optical Specification

Optical Specification		
Operation Frequency		600MHz-1GHz,1.7GHz-2.2GHz, 3.3GHz-4GHz
Fiber Mode	/	Simplex
Wavelength	nm	1310, 1550 + WDM
Optical Output	MU	-2 – +2
	HUB	6-8
Return loss	dB	> 45
Connector Type	/	SC/APC

1.4.2 Cable Specification

Cable Specification		
Operation Frequency		DC-4GHZ
impedance	Ω	50
VSWR	/	≤1.2
Insert Loss	dB	≤ (L*0.48+0.2) dB@DC-4GHz @ meter

1.4.3 Radio Specification

Radio Specification									
			700MHz	850MHz	1900MHz	EAWS	2.5G band	C band	
Frequency	UL	MHz	698-716 / 777-787	824-849	1850 – 1915	1710 – 1755	2496-2690	3700-3980	
	DL		728-746 / 746-756	869-894	1930 – 1995	2110 – 2180			
IBW		MHz	18/10	25	65	45/70	194	280	
Carrier number (off-air card)							1	1	
Carrier IBW(off-air card)		MHz					194	200	
Uplink Output Power (PRRU)		dBm	+10——+20dBm input POI card:-40 +20——+37dBm input POI card: -50						
Uplink Output Power (BDA Card)		dBm	19	19	19	19	22	/	
Downlink max output power (ARU)		dBm	19	19	19	19	22	22	
Downlink input range (BDA Card)		dBm	-95 —— -50(RSRP)				-100—— -55(RSRP)		
Downlink input range (PRRU Card)		/	+10——+20dBm(RSSI) input +20——+37dBm(RSSI) input				+10——+20dBm(RSSI) input +20——+37dBm(RSSI) input		

UL max gain (BDA Card)	dB	80				80	/
DL max gain (BDA Card)	dB	80				80	80
UL max gain (PRRU Card)	dB	+10——+20dBm input: 10 +20——+37dBm input: 0					
DL max gain (PRRU Card)	dB	+10——+20dBm input: 10 +20——+37dBm input: 0					
ATT adjust range	dB	MU: 0 – 30, ARU: 0 – 20					
In-band ripple(P-P)	dB	≤ 4	≤ 6	≤ 6	≤ 6	≤ 6	≤ 6
Emission spur		FCC	FCC	FCC	FCC	FCC	FCC
UL NF at max gain	dB	≤ 10					
System delay (BDA Card)	usec	≤ 10					
System delay (PRRU Card)	usec	≤ 3					
Input VSWR		≤ 1.5					
MU Max input power (BDA Card)	dBm	-10					
MU Max input power (PRRU Card)	dBm	37					
ARU Max input RF power	dBm	-10					

1.5 INSTALLATION

1.6 WARNINGS AND ALERTS

Laser

Laser light can cause damage to eyes. Laser light is not visible. Viewing it directly does not cause pain. The iris of the eye will not close when viewing a bright light. Consequently, serious damage to the retina of the eye is possible. NEVER LOOK INTO THE END OF A FIBER WHICH MAY HAVE A LASER COUPLED TO IT.

Radio Frequency Energies

There may be situations, particularly for workplace environments near high-powered RF sources, where recommended limits for safe exposure of human beings to RF energy could be exceeded. In such cases, restrictive measures or actions may be necessary to ensure the safe use of RF energy.

High Voltage

The equipment has been designed and constructed to prevent practicable danger, as far as reasonably possible. Any work activity on or near equipment involving installation, operation or maintenance must be free from danger, as far as reasonably possible.

Where there is a risk of damage to electrical systems involving adverse weather, extreme temperatures, wet, corrosive or dirty conditions, flammable or explosive atmospheres, the system must be suitably installed to prevent danger.

Protective Earthing

Equipment provided for the purpose of protecting individuals from electrical risk must be suitable for the purpose and properly maintained and used.

Handling Precautions

This covers a range of activities including lifting, lowering, pushing, pulling, carrying, moving, holding or restraining an object or person. It also covers activities that require the use of force or effort, such as pulling a lever, or operating power tools.

Electrostatic Discharge (ESD)

Observe standard precautions for handling ESD-sensitive devices. Assume that all solid-state

electronic devices are ESD-sensitive. Ensure the use of a grounded wrist strap or equivalent while working with ESD-sensitive devices. Transport, store, and handle ESD-sensitive devices in static-safe environments.

WARNING

This is NOT a CONSUMER device. It is designed for installation by FCC LICENSEES and QUALIFIED INSTALLERS.

You MUST have an FCC LICENSE or express consent of an FCC License to operate this device. Unauthorized use may result

in significant forfeiture penalties, including penalties in excess of \$100,000 for each continuing violation.

The device not supports home/personal use.

Caution: for use of unauthorized antennas, cables, and/or coupling devices not conforming with ERP/EIRP restrictions is not permitted.

Antenna Type:	Internal Antenna
Antenna Gain:	Lower 700MHz: 4dBi
	Upper 700MHz: 4dBi
	Cellular: 4dBi
	EAWS: 4dBi
	Broadband PCS: 4dBi
	BRS/EBS: 5dBi
	3.7GHz Service: 3dBi

This device is an industrial-leading in-building distributed antenna solution and restricted indoor use only.

This equipment complies with FCC radiation exposure limits set forth for an uncontrolled environment. This equipment should be installed and operated with a minimum distance of 20cm between the radiator and your body. This transmitter must not be co-located or operating in conjunction with any other antenna or transmitter.

The installation height of the antenna for AWS 1710-1755MHz band operation is limited 10 meters above ground for compliance with section 27.50.

1.7 SITE PLANNING CONSIDERATIONS

1.7.1 SITE PLANNING

Site Considerations

The MU is designed to be located indoors to facilitate coupling of BTS signals and power supply connections. The input range of MU RF unit is 10~30 dBm.

The site consideration for HUB is listed below:

- The maximum fiber maximum path loss of 8dB.
- The system delay of the optical system must be taken into consideration when there are neighboring BTS sites overlapping in coverage.

Installation Location

Mounting surface shall be capable of supporting the weight of the equipment.

In order to avoid electromagnetic interference, a proper mounting location must be selected to minimize interference from electromagnetic sources such as large electrical equipment.

Environmental

Humidity has an adverse effect on the reliability of the equipment. It is recommended to install the equipment in locations having stable temperature and unrestricted air-flow.

The installation location for the system should be well ventilated. The equipment has been designed to operate at the temperature range and humidity level as stated in the product specifications.

Grounding Requirement

Verify that the equipment has been well grounded. This includes antennas and all cables connected to the system. Ensure lightning protection for the antennas is properly grounded.

Cable Routing

Depending on equipment configuration, a variety of types of cables are connected to the MU HUB

and RU: coaxial cables, optical fibers, power cable, communication cable, and commissioning cable. Where applicable, ensure cables are properly routed and secured so that they are not damaged.

Manual Handling

During transportation and installation, take necessary handling precautions to avoid potential physical injury to the installation personnel and the equipment.

1.7.2 SYSTEM INSTALLATION CHECKLIST

- Working space available for installation and maintenance for each mounting arrangement. Ensure unrestricted airflow.
- Ensure earthing point is within reach of the ground wire. (2m; 6 ft. 10 in.).
- Ensure a power source is within reach of the power cord and the power source has sufficient capacity.
- Where appropriate, ensure unused RF connectors are terminated.
- Where appropriate, ensure unused optical fiber connectors are protected.
- Do not locate the equipment near large transformers or motors that may cause electromagnetic interference.
- Reduce signal loss in feeder cable by minimizing the length and number of RF connections.
- Ensure the equipment will be operated within the stated environment (refer to datasheet).
- Where needed, couple BTS RF signal with a coupler to prevent damaging the equipment.
- Where appropriate, confirm availability of suitably terminated grade of RF and optical fiber.
- Observe handling of all cables to prevent damage.

1.8 INSTALLATION PROCEDURES





1.8.1 GOODS INWARDS INSPECTION

ComFlex was factory tested, inspected, packed, and delivered to the carrier with utmost care. Do not accept shipment from carrier which shows damage or shortage until the carrier's agent endorses a statement of the irregularity on the face of the carrier's receipt. Without documentary evidence, a claim cannot be processed.

Open and check each package against the packing list. For any shortage, contact Comba Telecom Systems. Do not remove items from packing materials until installation.

1.8.2 TOOLS

See for a full list of tools required for installation and maintenance.

Tool Type	use	Usage Scenario
Impact drill 	Drill installation holes to fit M8 expansion bolts	Wall hanging
adjustable wrench 	Fix the bolt and tighten the M8 hex nut	Wall hanging
Pentagonal wrench 	Fixing screw	Wall hanging
Cross screwdriver 	Fixing screws, ϕ 5mm	Wall hanging

1.8.3 PREPARATION

Optical Fiber:

- Fiber optic cables require proper handling. Do not stretch, puncture, or crush the fiber cable(s) with staples, heavy equipment, doors, etc.
- Always maintain the minimum bending radius specified by the cable manufacturer. The minimum bend radius is usually 10 times the cable's outer diameter. In the case of single optical fiber that is not in a cable, the minimum bending radius to be observed is 3cm. (1.2") .

1.8.4 MU install

MU consists of three parts: MU chassis, RFU, and FOU. All components are individually packaged. Install the MU chassis on the rack first, then insert the RFU module and FOU module into the MU chassis

Figure 1: MU unit

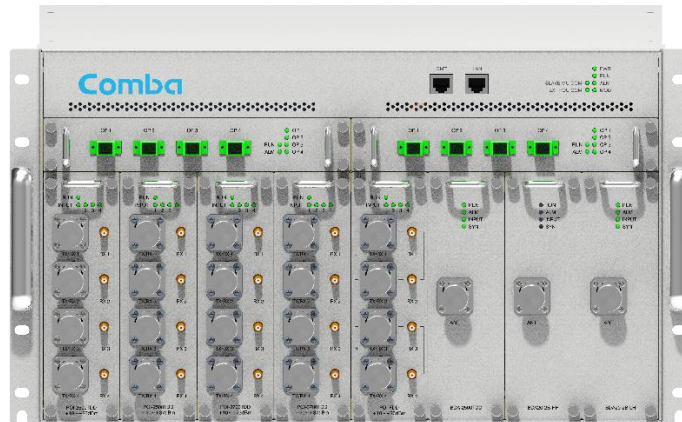

1.8.5 MU chassis mounted in a 19 inch rack

The MU chassis is a 19 inch rack mounted device with a height of 6U, which can be installed into a 19 inch rack as follows:

Figure 2: 19 inch rack

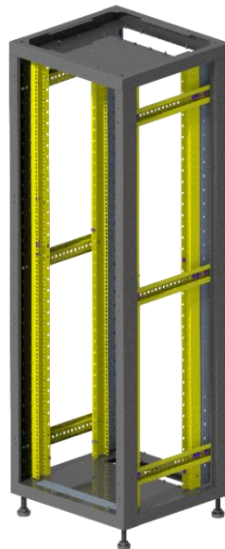

Step 1: Determine the installation position of the MU chassis on the rack, install cabinet nuts on the corresponding holes on both sides of the rack as shown in Figure 3, and install cabinet screws on the 1U cabinet nuts on both sides. The cabinet screws are only screwed in half the length.

Figure 3: Install cabinet nuts and support screws



Step 2: Place the MU chassis inside the rack, with the notches at the bottom of the hanging ears on both sides slightly higher than the cabinet screws. Then slide the MU chassis down to make the cabinet screws snap into the notches.

Figure 4: Install cabinet nuts and support screws

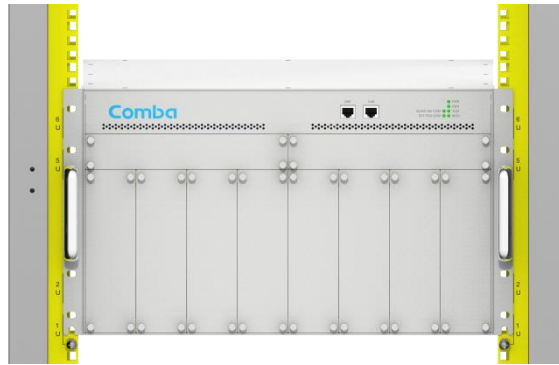

Step 3: Install the remaining 6 cabinet screws on both sides of the MU chassis, tighten the 8 screws (including the pre installed 2 cabinet screws), and complete the installation of the MU chassis.

Figure 5: Install cabinet nuts and support screws



1.8.6 RFU and FOU installation

Step1: RFU module installation: Remove the baffle of the RFU slot in the MU chassis, insert the RFU module, and tighten the fastening screws on the module (10 RFU modules can be inserted into any of 8 RFU slots)



Figure 6: RF Unit Installation

Step2: FOU module installation: Remove the FOU slot baffle from the MU chassis, insert the FOU module, and tighten the fastening screws (FOU module can be inserted into any of the 2 FOU slots)

Figure 7: FOU Installation

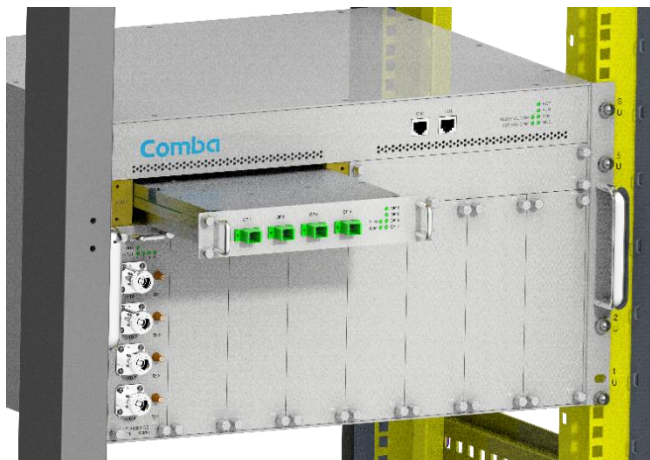

1.8.7 HUB Wall mounted installation

Install HUB onto the wall as follows

Step 1: Choose the appropriate wall position:

The wall can safely bear the weight of HUB

Capable of comfortable wiring at the top and bottom of the HUB

Step 2: Drill installation holes and fix the installation bracket

Use a mounting bracket as a template to mark the positions of four installation holes on the wall. Use a $\varnothing 10$ impact drill bit to drill installation holes for M8 expansion bolts, with a depth of no less than 50mm.

Install the expansion bolts into the wall, and then fix the installation bracket to the wall through the expansion bolts

Figure 8: Punch installation holes and fix the installation bracket

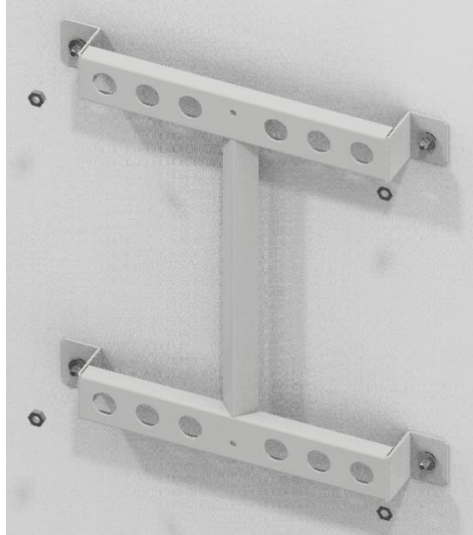

Step 3: Hang HUB

Hang the HUB on the fixed mounting bracket

Figure 9: Hang HUB

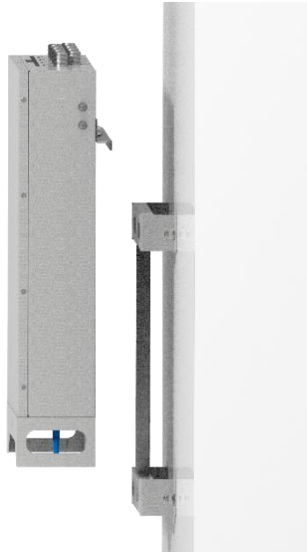

Step 3: Fix HUB and complete installation

At the middle of the bottom of the HUB, use an M6X16 screw to secure the HUB chassis and mounting bracket

together to complete the installation.

Figure 10: Tighten the chassis screws

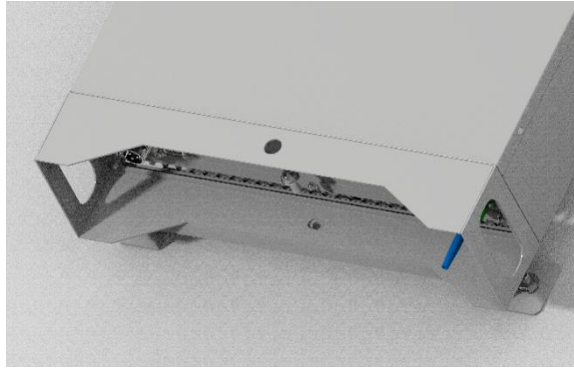

1.8.8 ARUinstall

1.3.6.1 Hanger installation

In the scenario where ARU is fixed with a suspension rod, complete the installation as follows.

Step 1: Fix hanger 1 on the suspension rod.

Use nuts and washers to fix Hanger 1 to the already set suspension rod on site (nuts and washers need to be provided by oneself, supporting M8 to M12 suspension rods)

Figure 11: Hanger 1 mounted on the boom

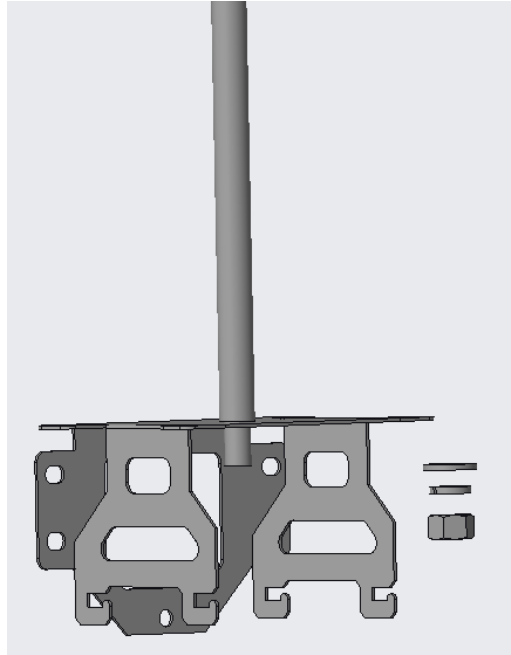

Step 2: Mount Hanger 1 on the boom and secure Hanger 2 to the ARU.
Use M4X10 screws to secure mounting bracket 2 to the ARU.

Figure 12: ARU mounting rack 2

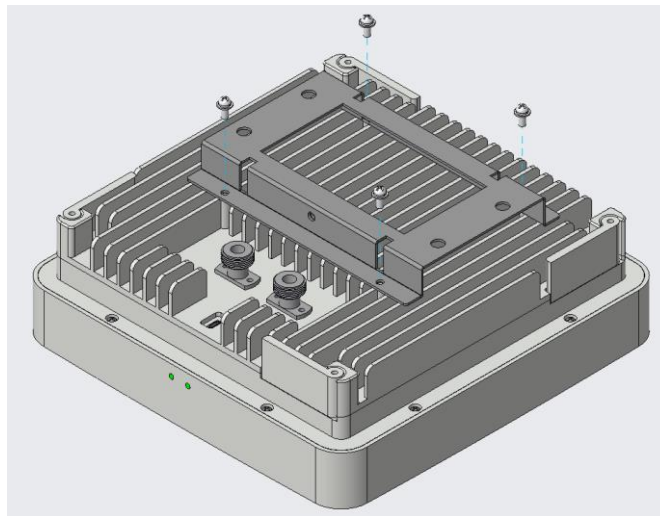

Step 3: Hang the ARU, tighten the screws, and complete the installation.
Hang the ARU on rack 1, tighten the fastening screws on rack 1, and complete the installation.

Figure 13: ARU mounting rack 2

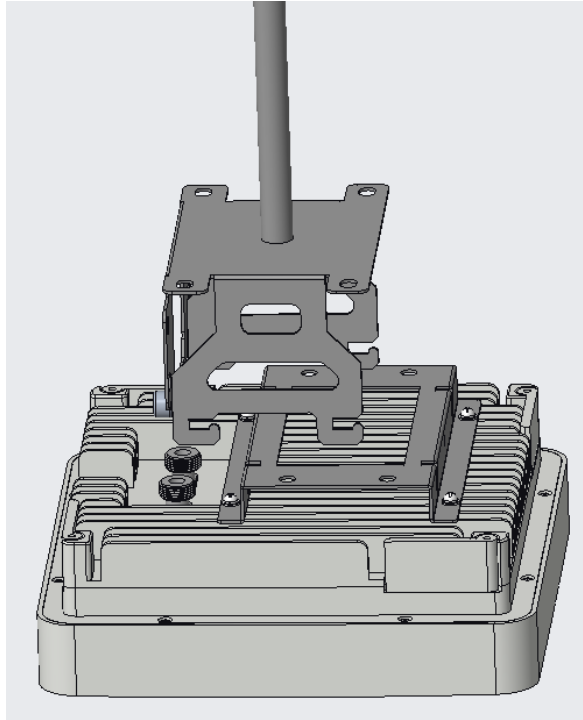

1.3.6.2 Installation of wooden beams

Step 1: Fix the hanger 1 on the wooden beam.

Use four ST6.3X30 wood screws to secure the hanging bracket 1 to the wooden beam.

Figure 14: Hanger 1 fixed to wooden beam

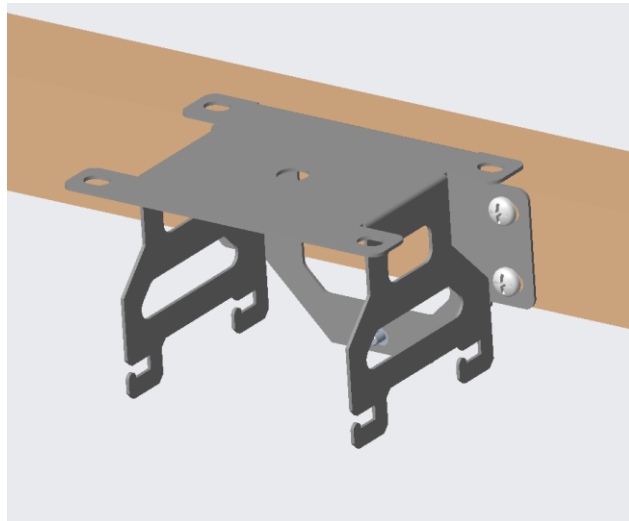

Step 2: Secure rack 2 to the ARU.

Use M4X10 screws to secure mounting bracket 2 to the ARU.

Figure 15: ARU MOUNTING RACK 2

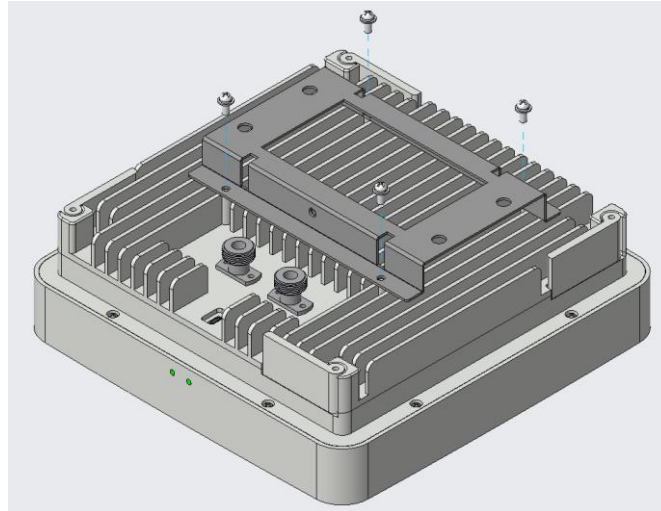

Step 3: Hang the ARU, tighten the screws, and complete the installation.

Hang the ARU on rack 1, tighten the fastening screws on rack 1, and complete the installation.

Figure 16: ARU MOUNTING RACK 2

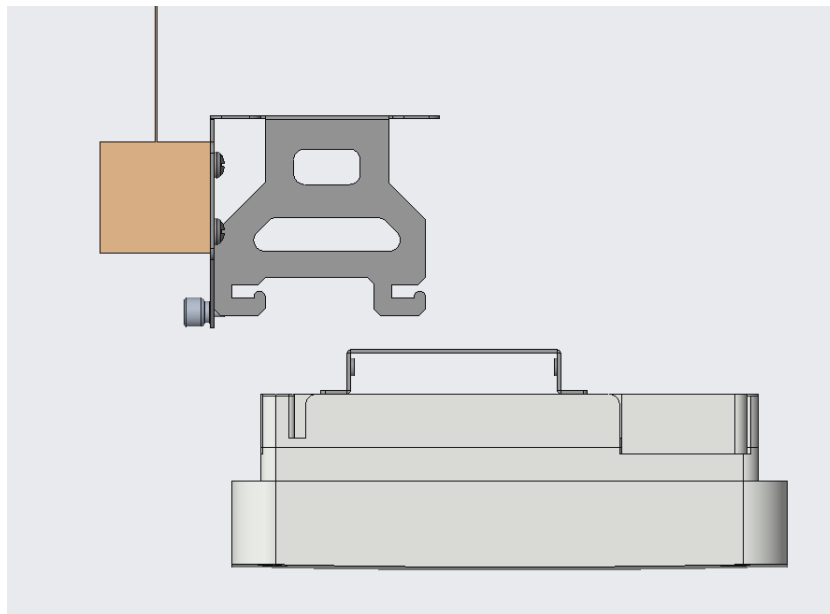

1.3.6.3 Wall mounted installation

Step 1: Fix hanger 1 on the wall.

Use hanging bracket 1 as a template to mark the drilling position on the wall, and use a $\varnothing 8$ impact drill bit to drill the installation hole for M6 expansion bolt, with a drilling depth of no less than 40mm.

Install the expansion bolts into the wall, and then fix the installation bracket to the wall through the expansion bolts

Figure 17: Hanger 1 fixed to the wall

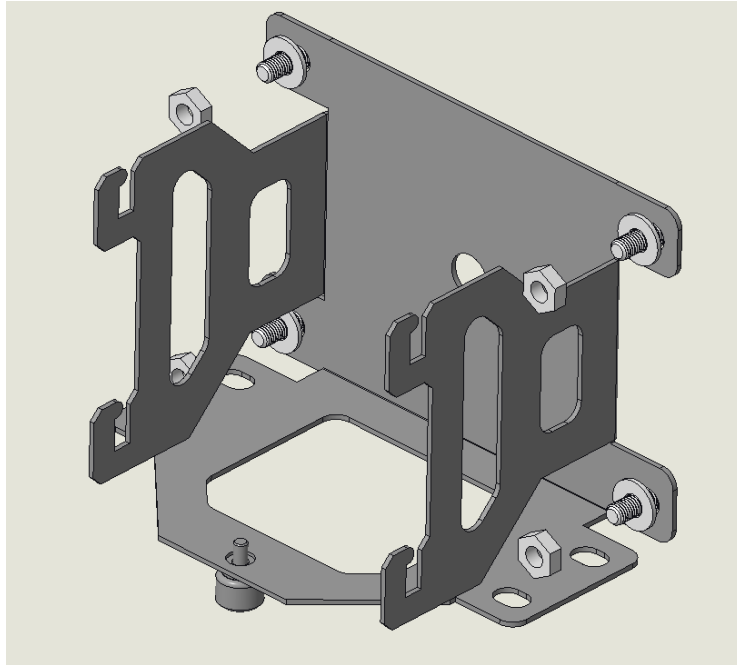

Step 2: Secure rack 2 to the ARU.

Use M4X10 screws to secure mounting bracket 2 to the ARU.

Figure 18: ARU MOUNTING RACK 2

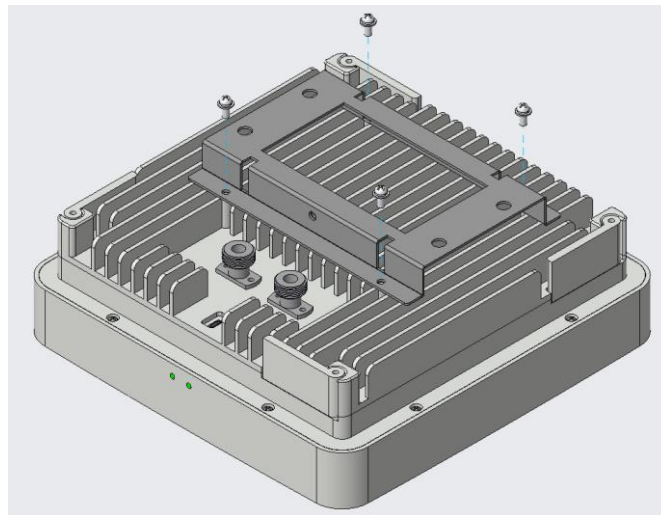

Step 3: Hang the ARU, tighten the screws, and complete the installation.

Hang the ARU on rack 1, tighten the fastening screws on rack 1, and complete the installation.

Figure 19: ARU hanging into rack 2

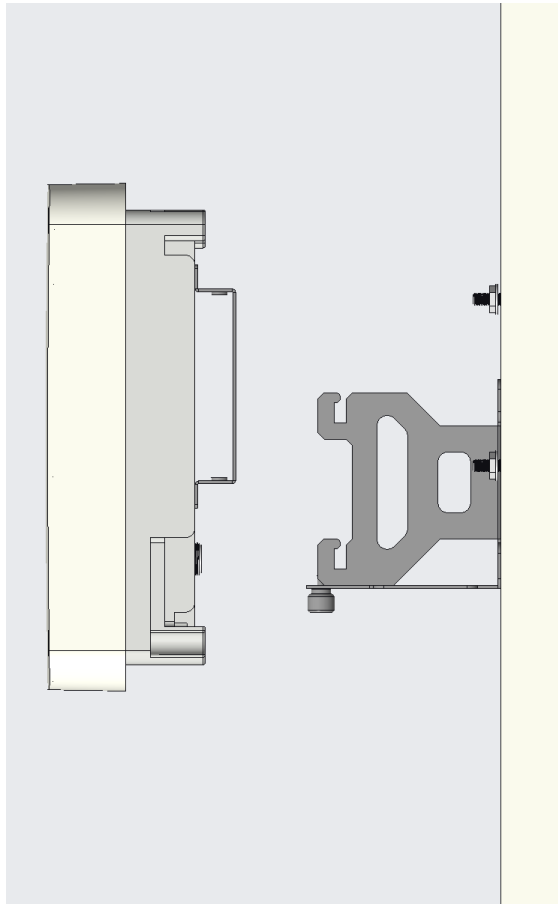

1.3.6.4 Installation of ceiling gantry

Step 1: Fix the screw onto the mounting bracket 2.

Fix the screw onto the mounting bracket 2 using M6 nuts and washers.

Figure 20: Install bracket 2 onto the screw

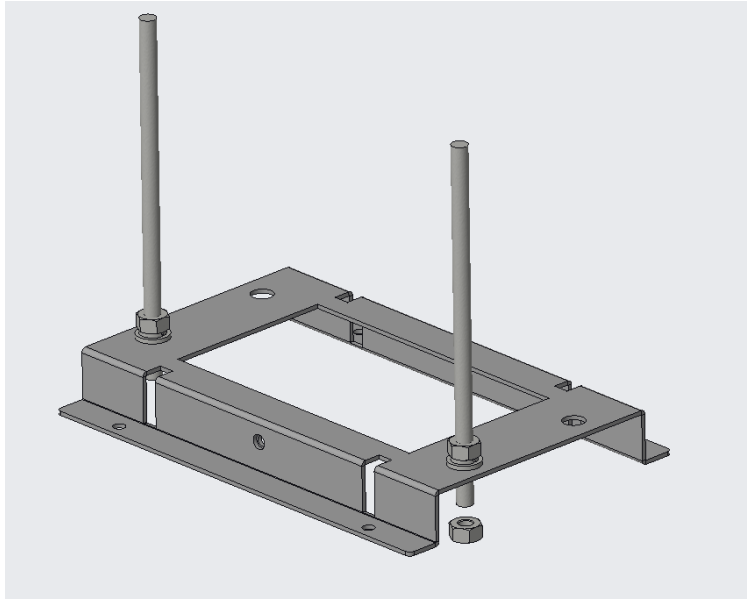

Step 2: Secure rack 2 to the ARU.

Use M4X10 screws to secure mounting bracket 2 to the ARU.

Figure 21: Installation rack 2 installed on ARU

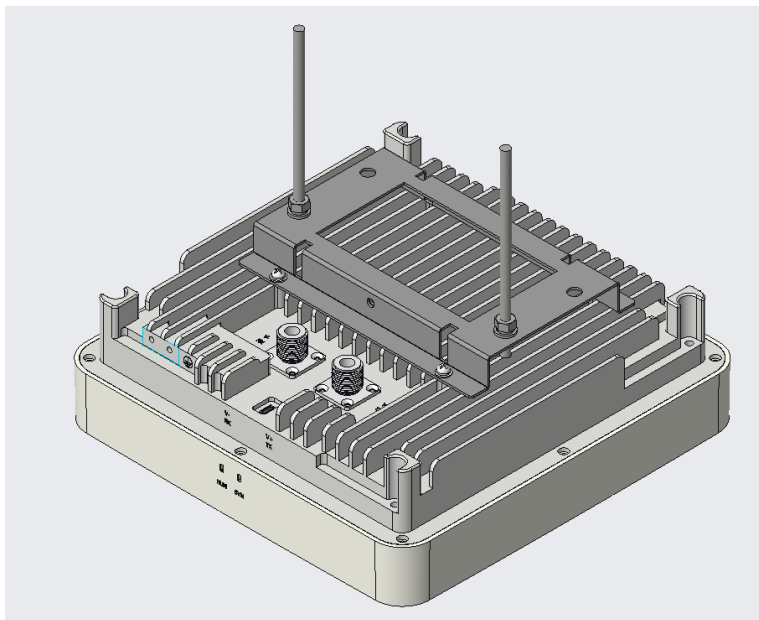

Step 3: Fix the ARU on the gantry.

Use M6 ordinary nuts and butterfly nuts to fix the ARU on the gantry through screws and adjust the appropriate height.

Figure 22: Installation rack 2 installed on ARU

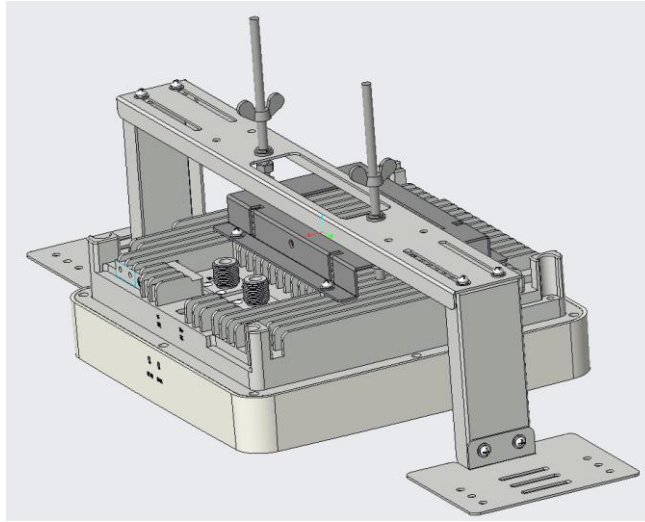

Step 4: Place the gantry on the ceiling and complete the installation.

Adjust the width of the gantry to the appropriate position, and then place the entire structure on the ceiling to complete the installation.

Figure 23: Place the gantry on the ceiling

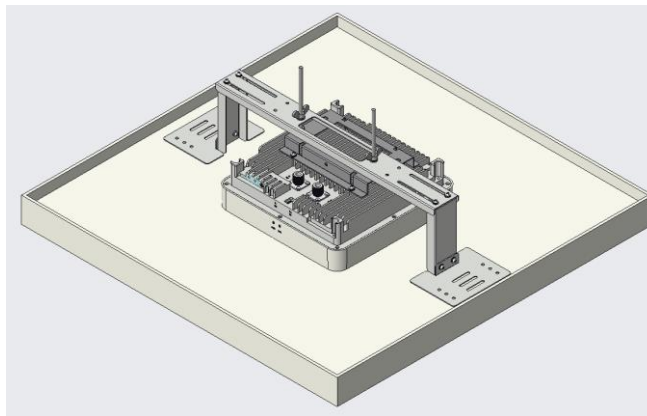

1.3.6.5 Ceiling mounted installation

Step 1: Ceiling openings.

Use a hole template to create a square hole in the ceiling.

Figure 24: Opening square holes in the ceiling

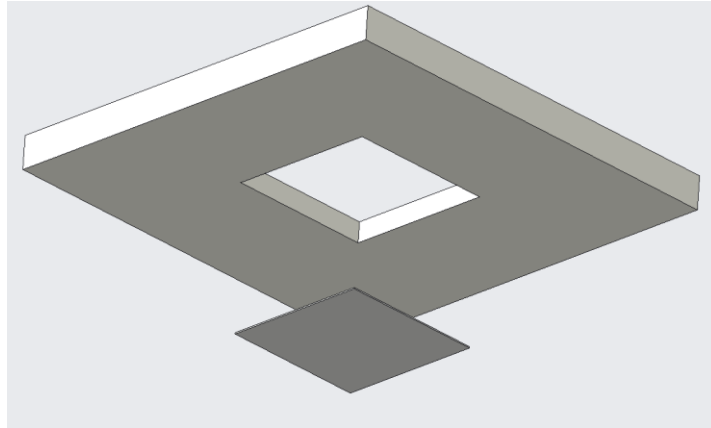

Step 2: Loosen the corner part screws.

Remove the four plugs from the top cover and loosen the screws that secure the corner pieces. The spacing between the corner pieces to be loosened is determined by the thickness of the ceiling.

Figure 25: Loosen the screws of the corner piece

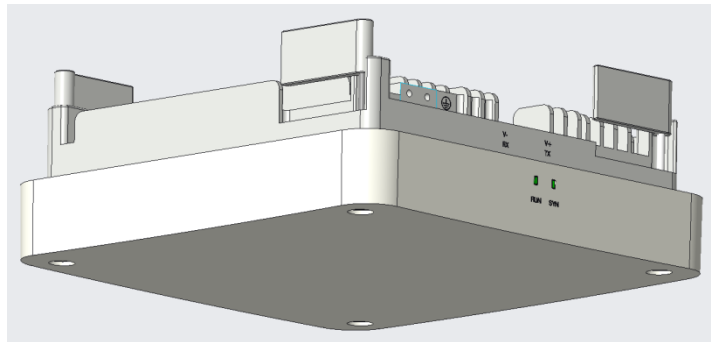

Step 3: Place the ARU in the ceiling.

Place the ARU into the square hole in the ceiling that has been opened, and use a screwdriver to rotate the fixing screw of the corner piece. The fixing screw will drive the corner piece to rotate and clamp onto the ceiling.

Figure 26: Loosen the screws of the corner piece

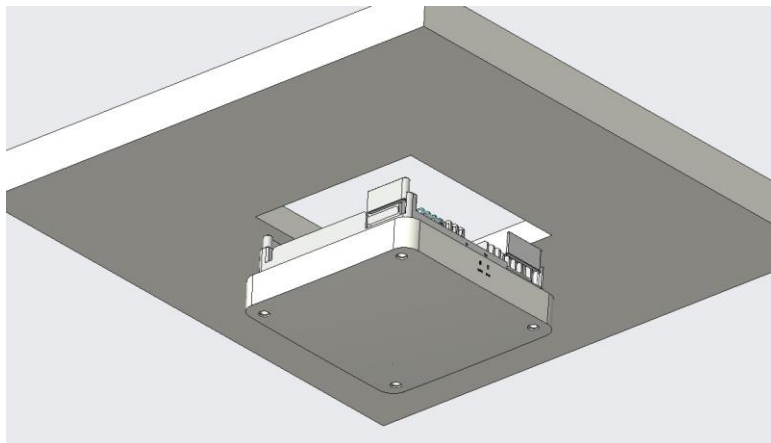
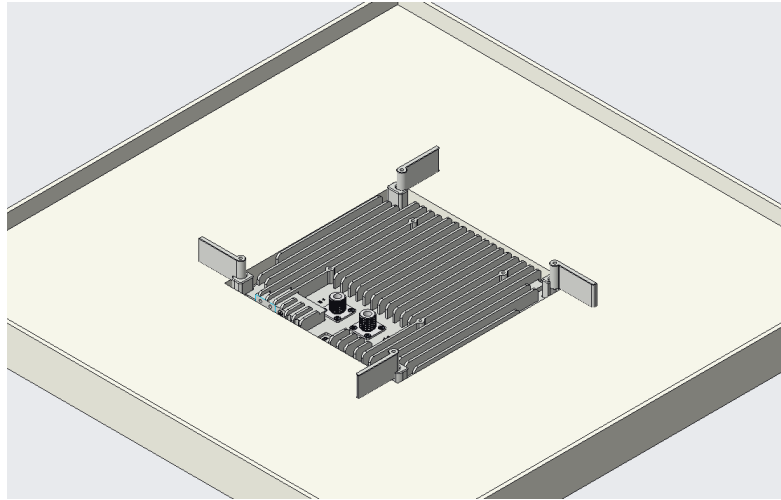

Figure 27: Corner pieces are clamped to the ceiling



Step 4: Tighten the screws to complete the installation.

Tighten the fixing screws and reinstall the plugs for the four holes to complete the installation.

Figure 28: Complete installation

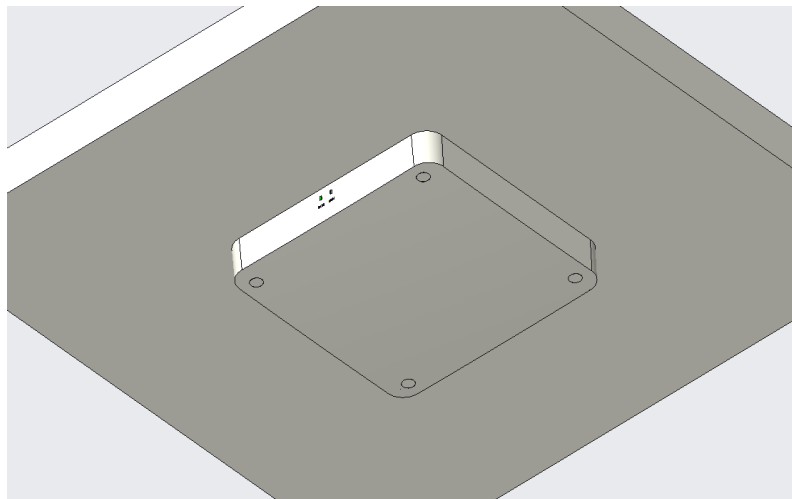

1.9 Equipment power supply

MU and HUB require 110V AC power supply, and the preferred power supply method is to use the power line cut off method. This power supply method requires single-phase electricity (110V AC) to be extracted from the three-phase electricity in the distribution cabinet

If there is no power cord cutting method available on site, use a socket to take 110V AC power. The power socket must be at a height that is not easily accessible by ordinary people to prevent manual unplugging of the base station power plug.

1.10 Equipment grounding

- 1) Use the resistance range of a multimeter, with one probe connected to the device's casing screw and one probe connected to the ground wire of the power socket. If the measured resistance value is relatively small (less than $10\ \Omega$), it is considered that the device has good grounding performance. If the resistance value is too large, it can be investigated from the following aspects:
 - Eliminate the problem with the multimeter itself: short circuit the two probes of the multimeter and observe if the resistance value is zero; The resistance value is zero, and the multimeter is normal; Not zero, abnormal multimeter.
 - Is the screw for equipment grounding tightened.
 - Is the grounding wire broken.
- 2) Touch the device casing with an electric pen. If the electric pen light is on, it indicates that there is current in the equipment casing and there is a leakage situation. Need to check if the equipment grounding is standard.

1.11 Cable connection

The fiber length insertion loss between MU and HUB shall not exceed 8dB, and the 5D cable insertion loss between HUB and the farthest ARU shall not exceed 45dB.

After the installation of MU, HUB, and ARU is completed, the installation interface needs to be connected and checked for accuracy before turning on the power and working normally.

1.12 Device identification

Each device, as well as wall mounted boxes and meter boxes, should be labeled clearly for future management and maintenance. The labels should be pasted in a visible area on the front of the equipment and equipment. The labels for each cable (such as 5D cable, power cord, tail fiber, etc.) are affixed at 20mm away from the wire head at both ends for easy reading and future management and maintenance. The labeling should be neat and clear.

The label of the device should be prominently placed on the device and not affect the overall harmony of the environment to maintain overall aesthetics. Warning signs must be attached to the host and power supply.

When there are multiple devices or lines running side by side, the labels must be placed on the same horizontal line

1.13 Power on inspection

After powering on, it is possible to observe whether the power supply, optical fiber, etc. are connected

properly, and whether the optical fiber and 5D cable are normal can be confirmed through the device indicator light.

1.14 Routine inspection

Equipment installation: Check whether the installation position of the equipment matches the design, and whether the installation is firm;

Power supply installation: Check whether the power supply is normal and whether the installation process of the power cord is qualified;

Site labels: Check if the equipment, power supply, and other labels are complete and labeled in a standardized manner;

Cable continuity: Use an optometry pen to test whether the physical link of the tail fiber is normal;

Equipment grounding integrity: Use a multimeter to test the resistance of the grounding wire to ground, etc.

Other: After powering on, check if the relevant indicator lights are on, etc