



Test Procedure: Measurements were in accordance with the test methods section 3.5.2 of KDB 935210 D05v01.

4.7 Measuring out-of-band/out-of-block (including intermodulation) and spurious emissions

Refer to the applicable rule part(s) for specified limits on unwanted (out-of-band/out-of-block and spurious) emissions (e.g., Section 90.210).

- a) Intermodulation products shall be measured using two CW signals with all available channel spacings (e.g., 12.5 kHz and 6.25 kHz) with the center between these channels being equal to the center frequency f_0 as determined from 4.4..

NOTE—Intermodulation-product spurious emission measurements are not required for single-channel boosters that cannot accommodate two simultaneous signals within the passband

Power measurement Method :

Guidance for performing input/output power measurements using a spectrum or signal analyzer is provided in 5.2 of KDB Publication 971168

Remark:

The notch filter is used for avoid the EUT fundamental carrier output power making the spectrum overload and the harmonic spurious brought by it.

When the EUT fundamental carrier is not enough to make the status, the notch filter could be not used.

7.2.5.1 Measurement Record:

Downlink: 450MHz to 509MHz

Channel spacings:6.25kHz

1.1 two signal input —Lower Edge

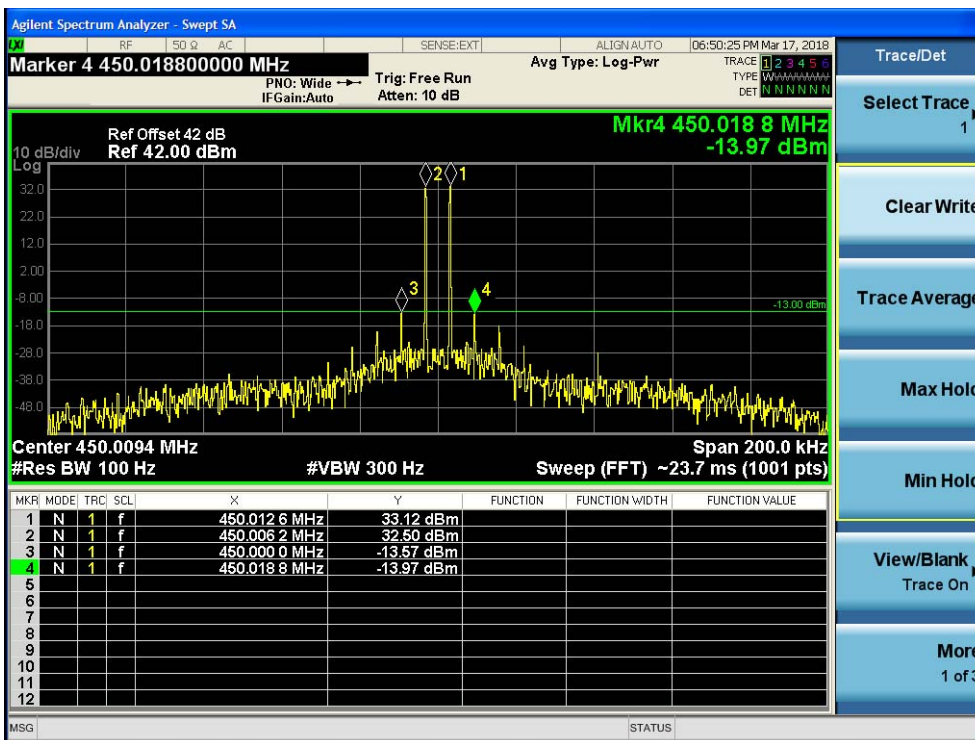

1.2 two signal input —Upper Edge

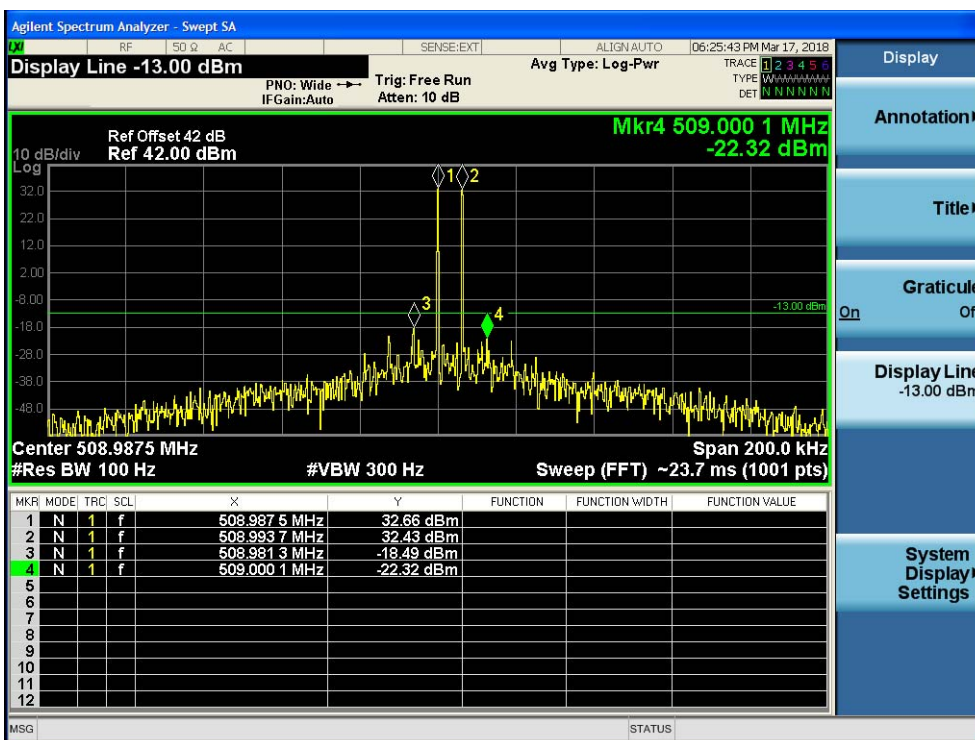



Channel spacings:12.5kHz

1.1 two signal input —Lower Edge

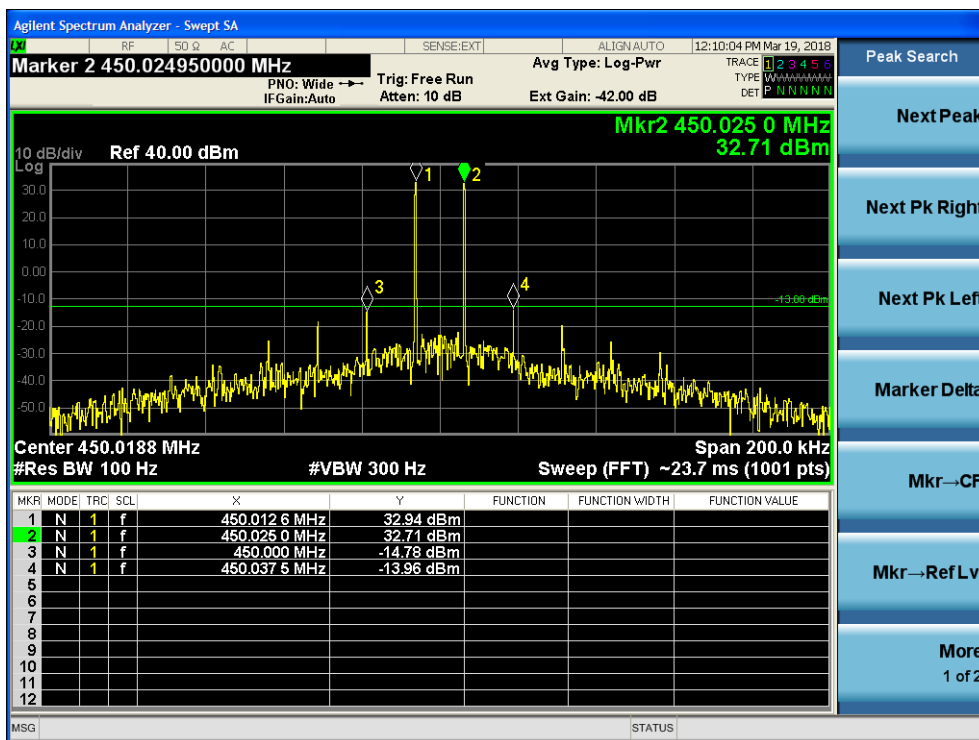

1.2 two signal input —Upper Edge

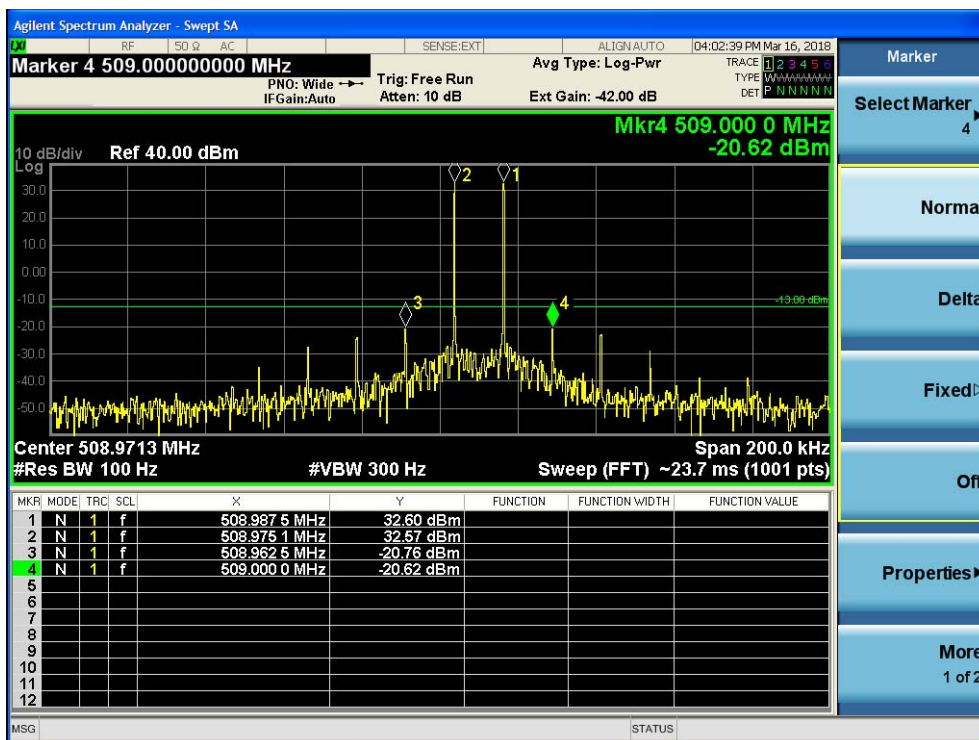



Channel spacings:25kHz

1.1 two signal input —Lower Edge

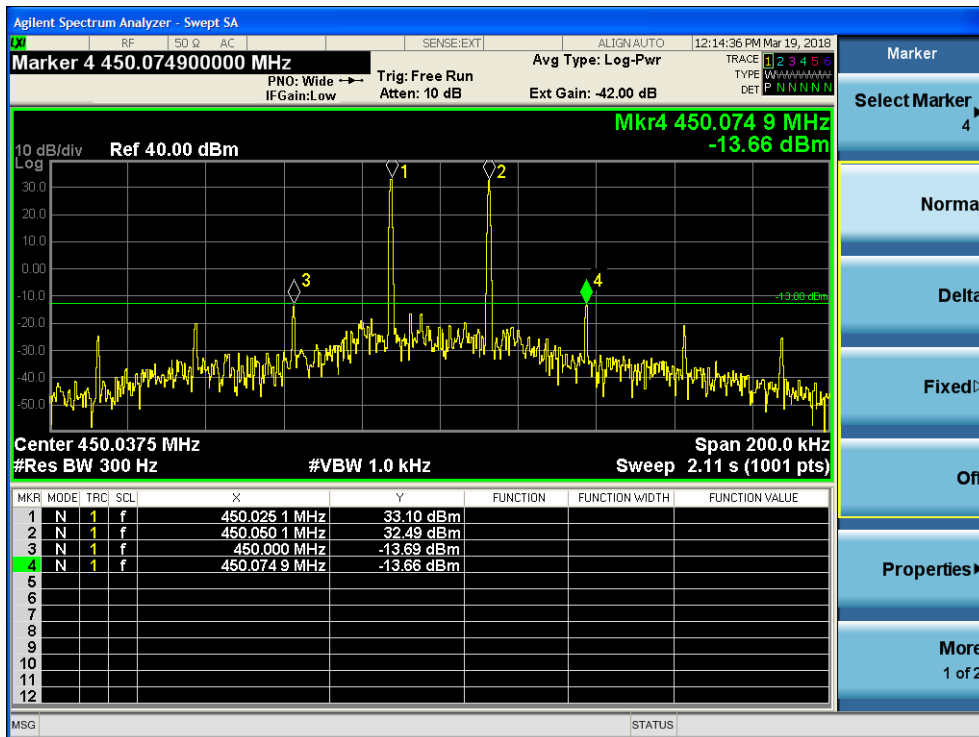

1.2 two signal input —Upper Edge

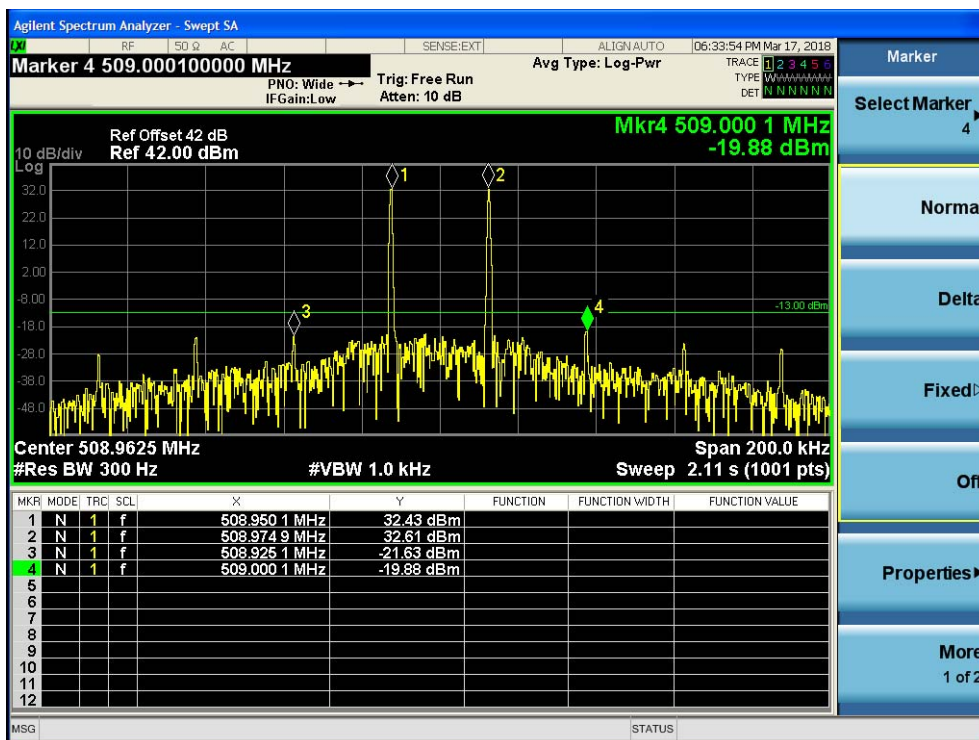



Downlink: 455MHz to 512MHz

Channel spacings:6.25kHz

1.1 two signal input —Lower Edge

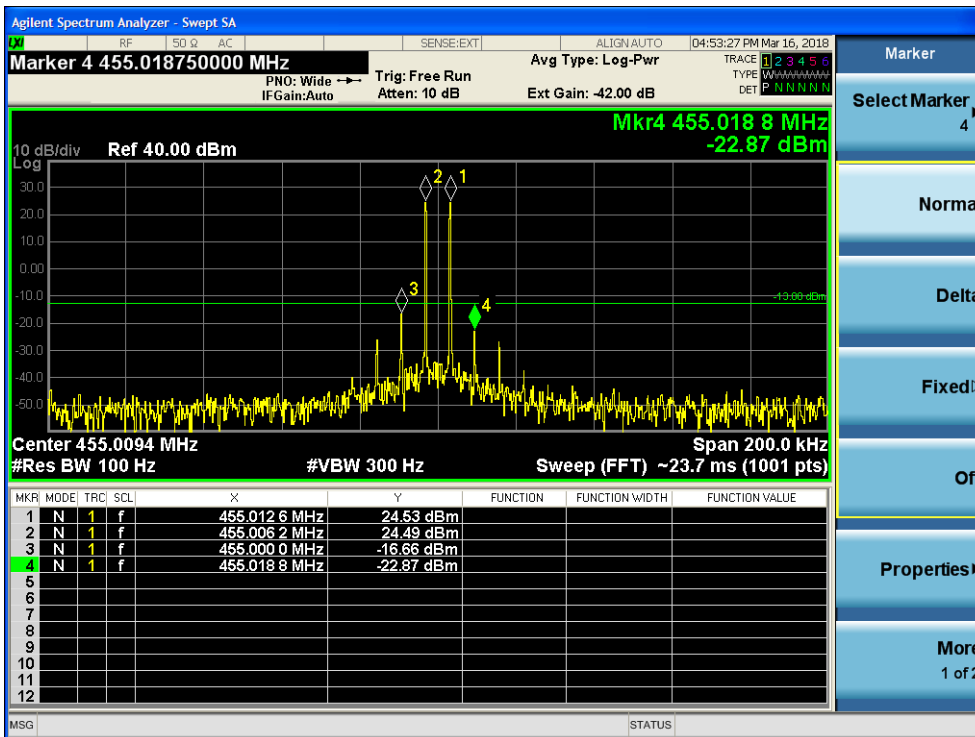

1.2 two signal input —Upper Edge

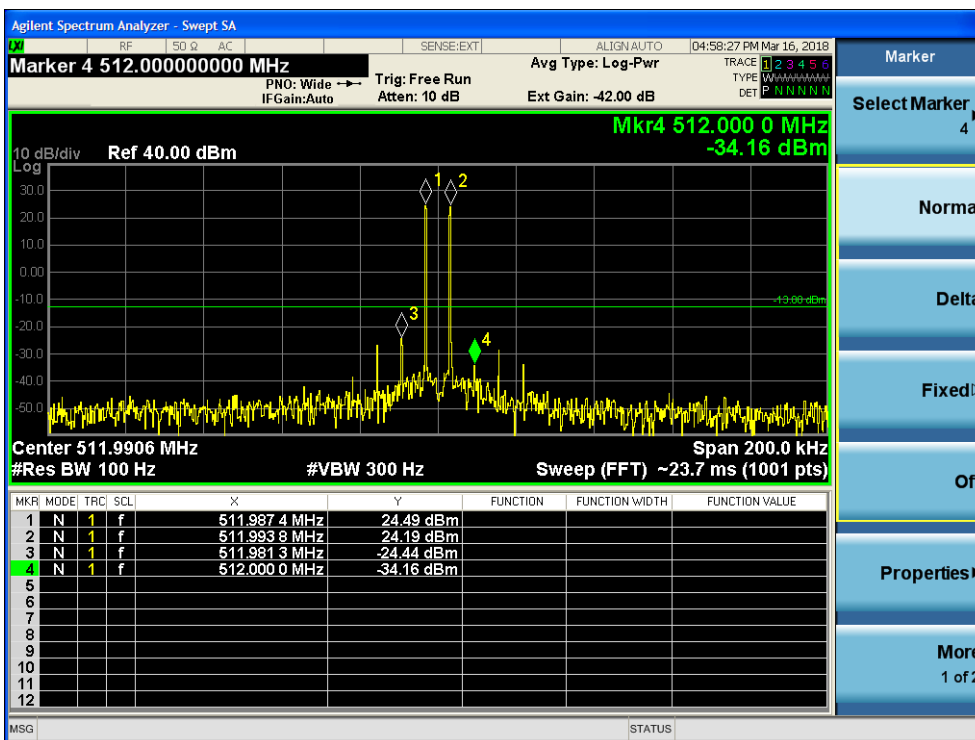



Channel spacings:12.5kHz

1.1 two signal input —Lower Edge

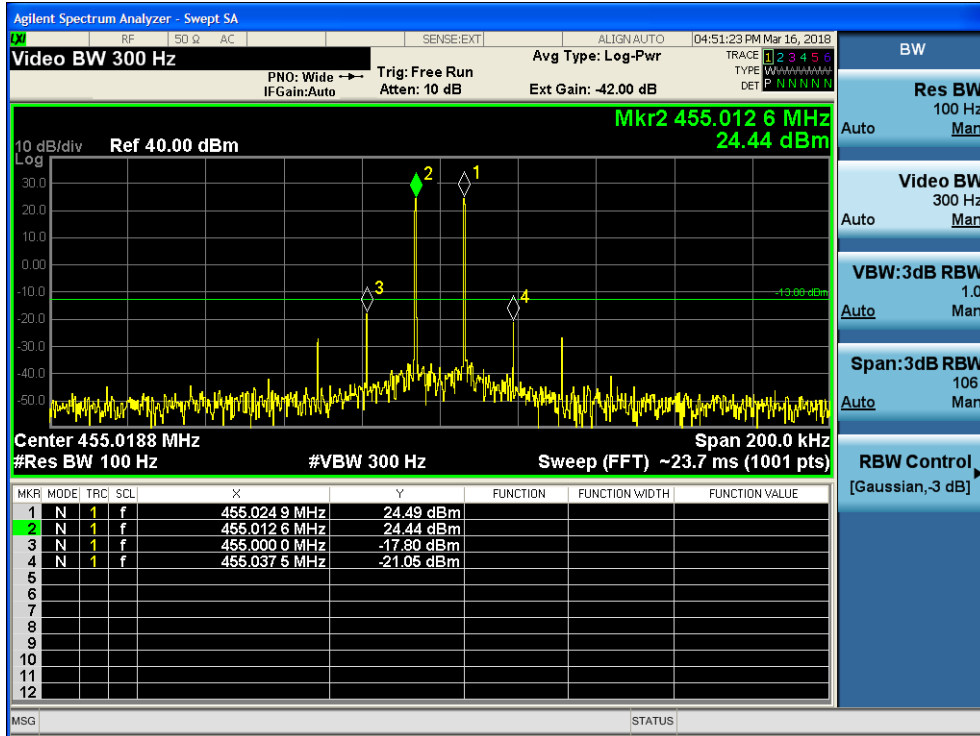

1.2 two signal input —Upper Edge

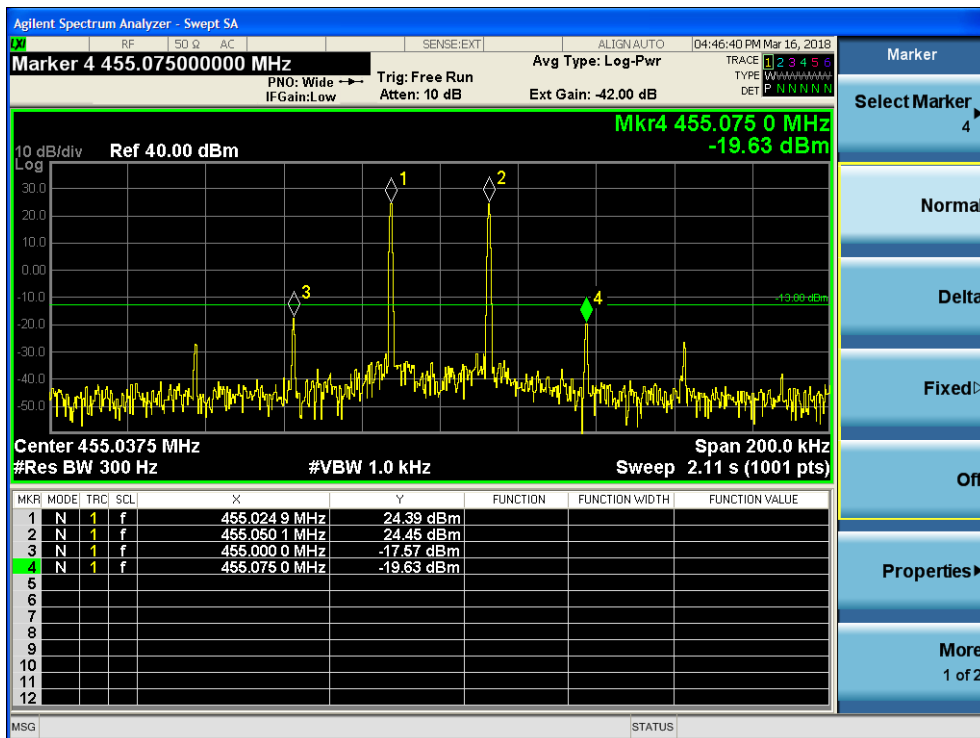

Channel spacings:25kHz

1.1 two signal input —Lower Edge

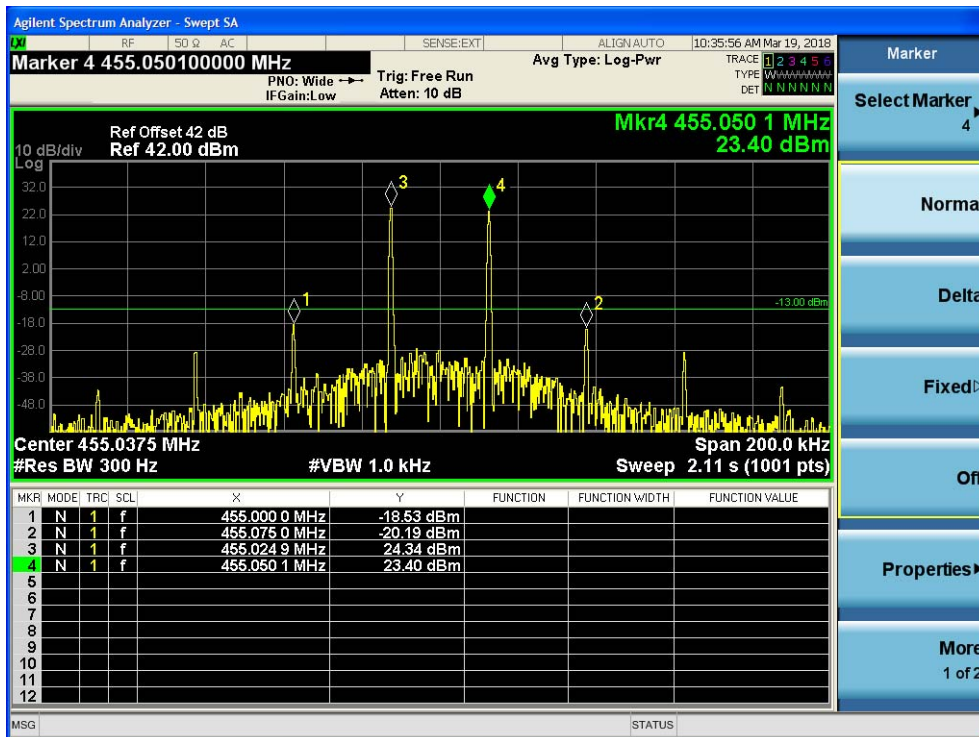

1.2 two signal input —Upper Edge

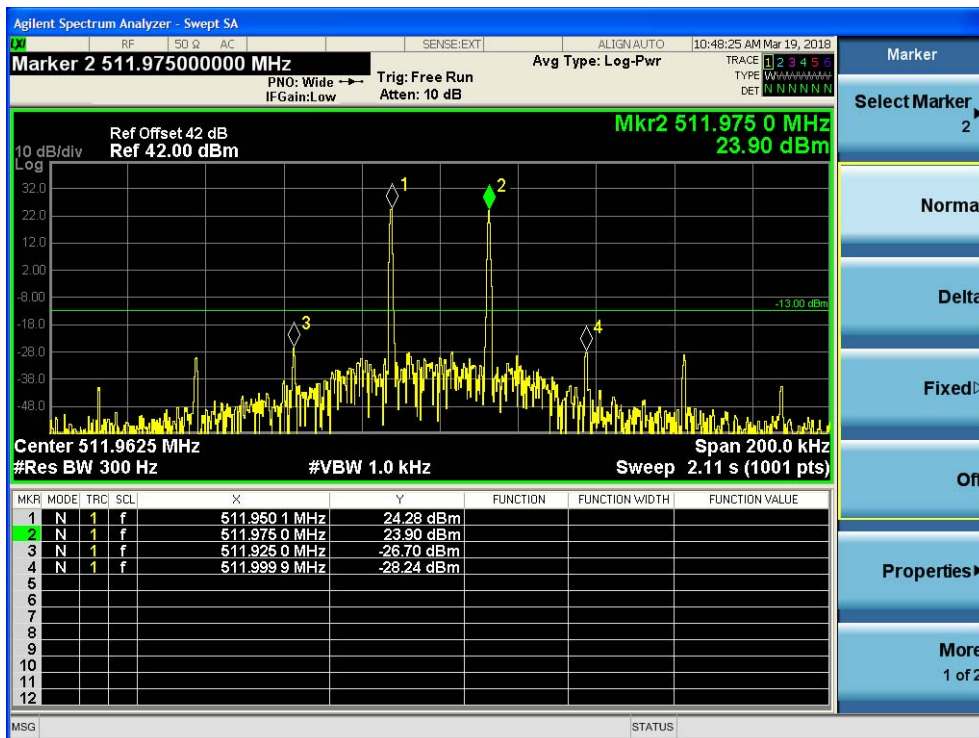

7.2.6 Noise Figure

Test Requirement: FCC part 90.219(e)
90.219(e)
A signal booster must meet
(2) The noise figure of a signal booster must not exceed 9dB in either direction.

Test Method: FCC part 2.1051

EUT Operation:
Status: Drive the EUT to maximum output power.
Conditions: Normal conditions
Application: Cellular Band RF output ports

Test Configuration:

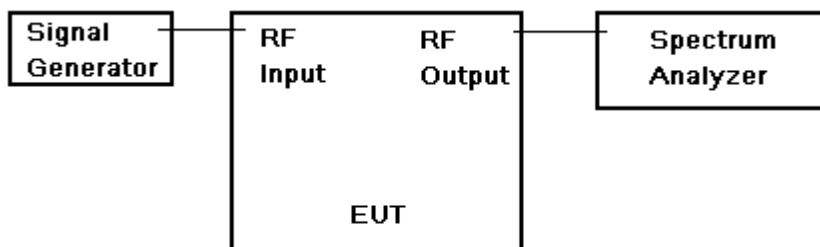
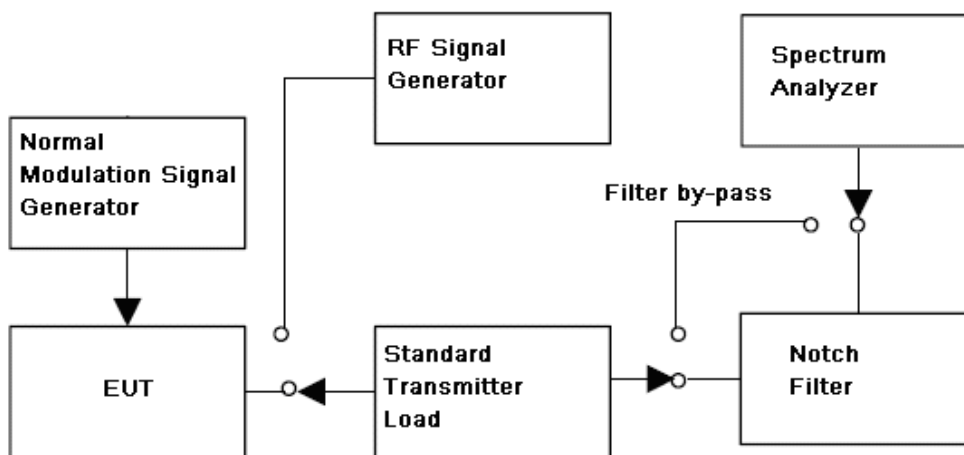

Fig.3. Band edge and Intermodulation test configuration





- Test Procedure: Measurements were in accordance with the test methods section 3.5.2 of KDB 935210 D05v01.
- a) Connect a signal generator to the input of the EUT.
 - b) Configure to generate the AWGN (broadband) test signal.
 - c) The frequency of the signal generator shall be set to the frequency of (f₀) as determined from 3.3.
 - d) Connect a spectrum analyzer or power meter to the output of the EUT using appropriate attenuation as necessary.
 - e) Set the signal generator output power to a level that produces an EUT output level that is just below the AGC threshold (see 3.2), but not more than 0.5 dB below.
 - f) Measure the output power of the EUT and record (Power measurement with a spectrum
 - g) Remove the EUT from the measurement setup and using the same signal generator settings, repeat the power measurement on the input signal to the EUT and record as input power.
 - h) Repeat the procedure with the narrowband test signal.
 - i) Repeat the procedure for both test signals with input signal amplitude set to 3 dB above the AGC threshold level.
 - j) Repeat for all frequency bands authorized for use by the EUT.

Power measurement Method :

Guidance for performing input/output power measurements using a spectrum or signal analyzer is provided in 5.2 of KDB Publication 971168

Remark:

The notch filter is used for avoid the EUT fundamental carrier output power making the spectrum overload and the harmonic spurious brought by it.

When the EUT fundamental carrier is not enough to make the status, the notch filter could be not used.

7.2.6.1 Measurement Record:

Downlink: 450MHz to 509MHz

1.1 lowest frequency

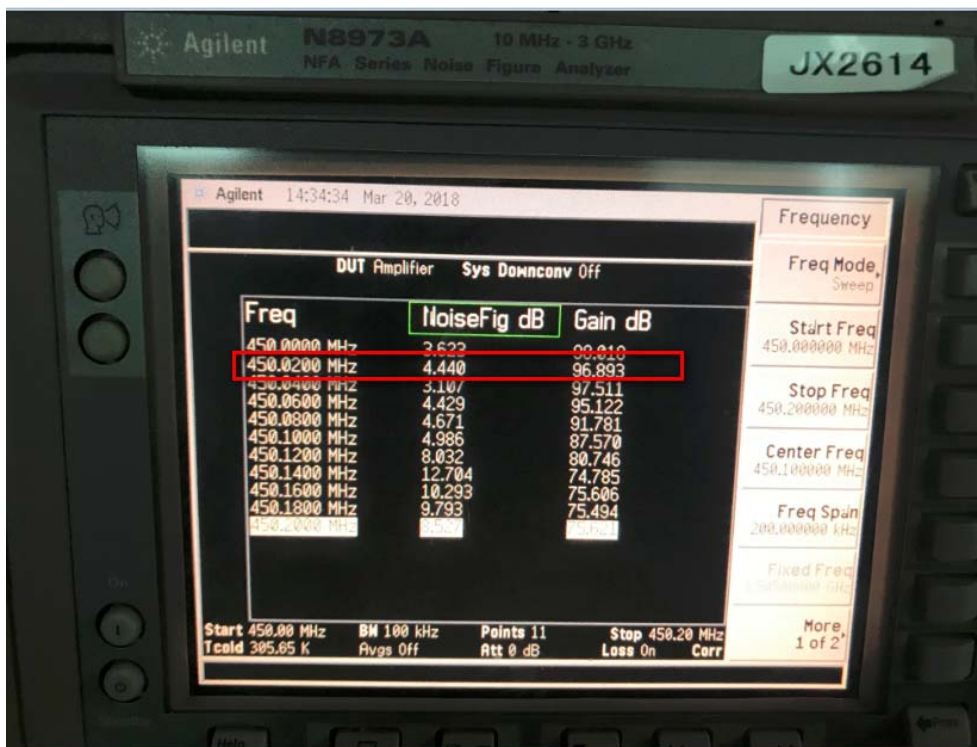

1.2 Middle frequency

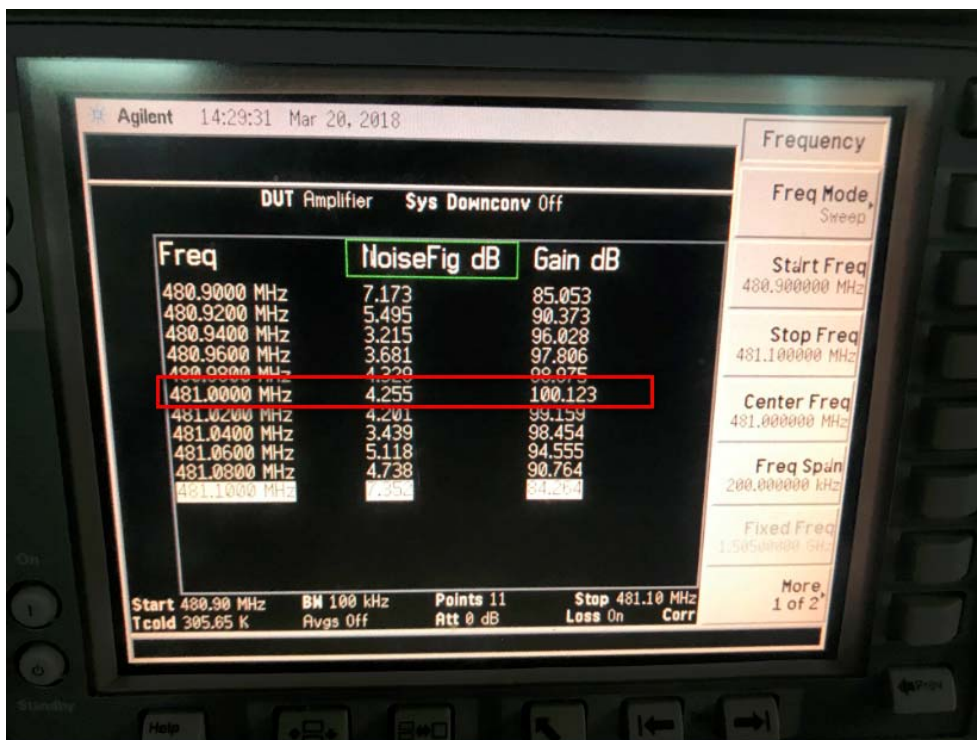

1.3 highest frequency

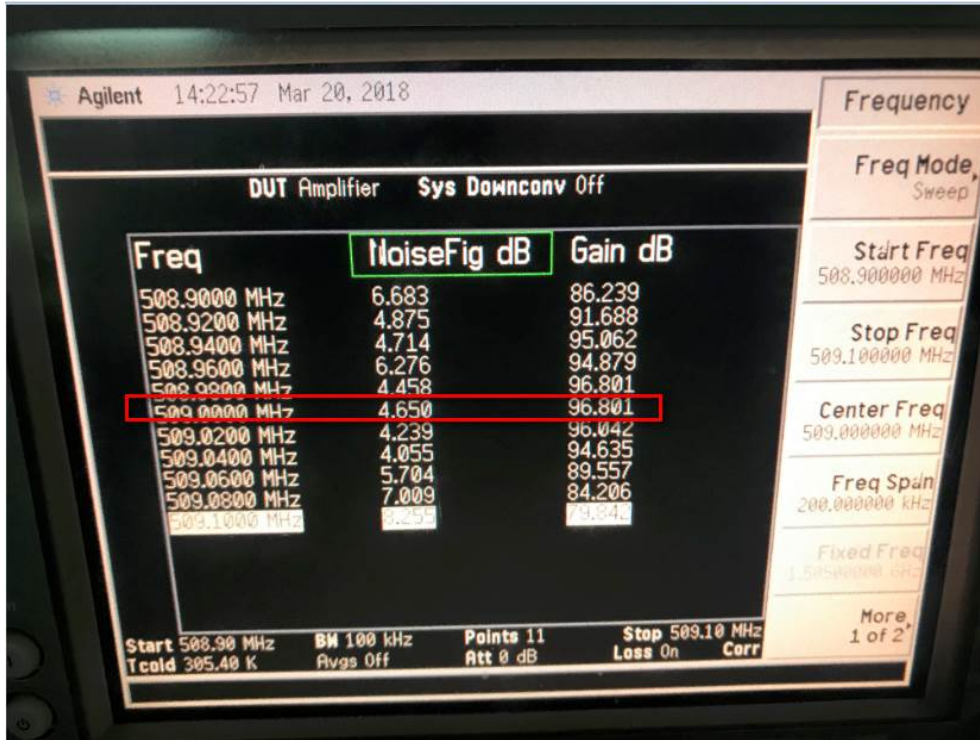

Downlink: 455MHz to 512MHz

1.1 lowest frequency

Agilent 13:54:04 Mar 20, 2018

DUT Amplifier Sys Downconv Off

Freq	NoiseFig dB	Gain dB
455.0000 MHz	2.720	97.300
455.0200 MHz	2.683	97.304
455.0400 MHz	2.713	96.673
455.0600 MHz	2.239	95.457
455.0800 MHz	3.066	91.184
455.1000 MHz	4.675	86.043
455.1200 MHz	6.165	80.009
455.1400 MHz	10.501	72.819
455.1600 MHz	20.937	60.896
455.1800 MHz	25.957	54.968
455.2000 MHz	17.103	62.890

Start 455.00 MHz BW 100 kHz Points 11 Stop 455.20 MHz
Tcold 305.90 K Avgs Off Att 0 dB Loss On Corr

User cal will be interpolated

1.2 Middle frequency

Agilent 14:07:08 Mar 20, 2018

DUT Amplifier Sys Downconv Off

Freq	NoiseFig dB	Gain dB
483.9000 MHz	4.356	82.719
483.9200 MHz	1.958	89.295
483.9400 MHz	3.186	91.961
483.9600 MHz	1.161	96.247
483.9800 MHz	2.425	96.289
484.0000 MHz	2.386	96.497
484.0200 MHz	1.467	96.875
484.0400 MHz	3.374	94.665
484.0600 MHz	2.005	93.092
484.0800 MHz	1.977	88.622
484.1000 MHz	4.390	81.831

Start 483.90 MHz BW 100 kHz Points 11 Stop 484.10 MHz
Tcold 305.90 K Avgs Off Att 0 dB Loss On Corr

1.3 highest frequency

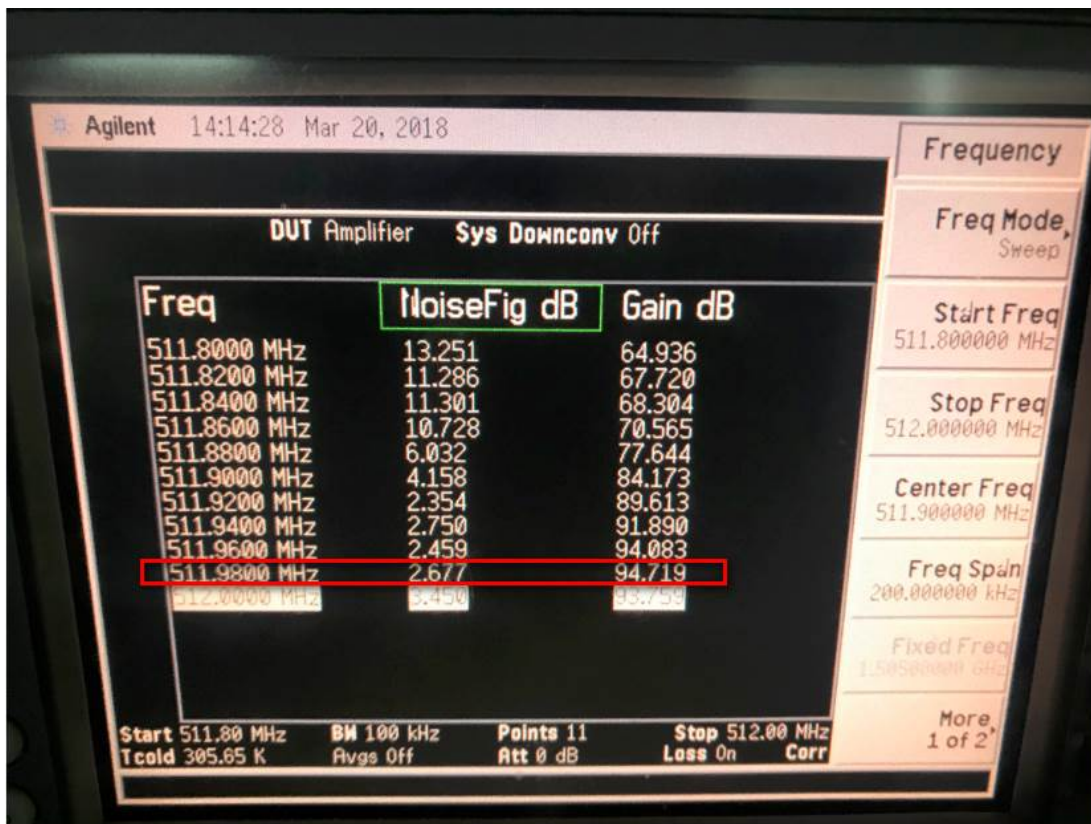

7.2.7 Noise at Antenna Terminals

Test Requirement: FCC part 90.219(e)(2) 90.219(d)(6)(ii)
90.219(e)

(6) Good engineering practice must be used in regard to the radiation of intermodulation products and noise, such that interference to licensed communications systems is avoided. In the event of harmful interference caused by any given deployment, the FCC may require additional attenuation or filtering of the emissions and/or noise from signal boosters or signal booster systems, as necessary to eliminate the interference.

(i) In general, the ERP of intermodulation products should not exceed -30 dBm in 10 kHz measurement bandwidth.

(ii) In general, the ERP of noise within the passband should not exceed -43 dBm in 10 kHz measurement bandwidth.

(iii) In general, the ERP of noise on spectrum more than 1 MHz outside of the passband should not exceed -70 dBm in a 10 kHz measurement bandwidth.

Test Method: FCC part 2.1051

EUT Operation:

Status: Drive the EUT to maximum output power.

Conditions: Normal conditions

Application: Cellular Band RF output ports

Test

Configuration:

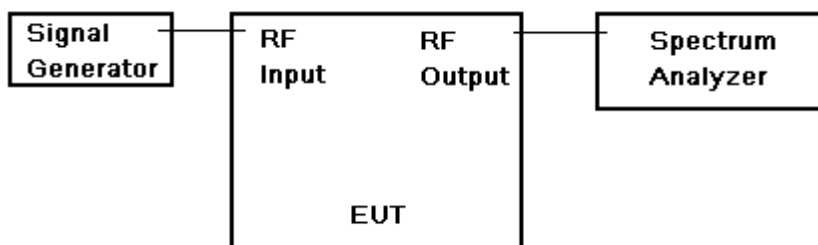
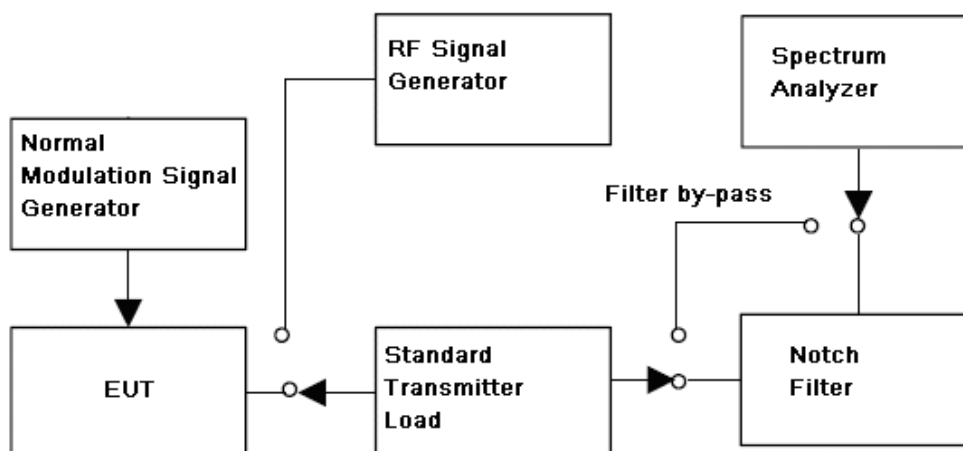

Fig.3. Band edge and Intermodulation test configuration





- Test Procedure: Measurements were in accordance with the test methods section 3.5.2 of KDB 935210 D05v01.
- a) Connect a signal generator to the input of the EUT.
 - b) Configure to generate the AWGN (broadband) test signal.
 - c) The frequency of the signal generator shall be set to the frequency of (f0) as determined from 3.3.
 - d) Connect a spectrum analyzer or power meter to the output of the EUT using appropriate attenuation as necessary.
 - e) Set the signal generator output power to a level that produces an EUT output level that is just below the AGC threshold (see 3.2), but not more than 0.5 dB below.
 - f) Measure the output power of the EUT and record (Power measurement with a spectrum
 - g) Remove the EUT from the measurement setup and using the same signal generator settings, repeat the power measurement on the input signal to the EUT and record as input power.
 - h) Repeat the procedure with the narrowband test signal.
 - i) Repeat the procedure for both test signals with input signal amplitude set to 3 dB above the AGC threshold level.
 - j) Repeat for all frequency bands authorized for use by the EUT.

Power measurement Method :

Guidance for performing input/output power measurements using a spectrum or signal analyzer is provided in 5.2 of KDB Publication 971168

Remark:

The notch filter is used for avoid the EUT fundamental carrier output power making the spectrum overload and the harmonic spurious brought by it.

When the EUT fundamental carrier is not enough to make the status, the notch filter could be not used.



7.2.7.1 Measurement Record:

Downlink: 450MHz to 509MHz

IN Band Amplifier noise

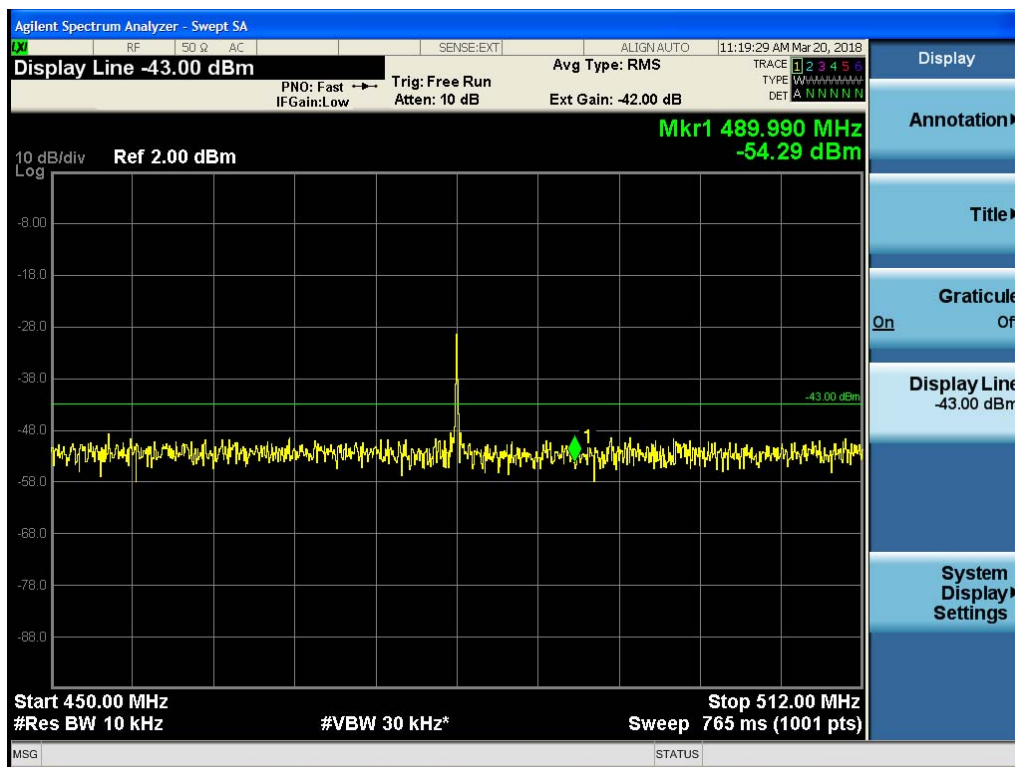

Out of band Amplifier noise: Please see the user manual for manufactures declaration on good engineering practice.

Uplink: 455MHz to 512MHz
IN Band Amplifier noise

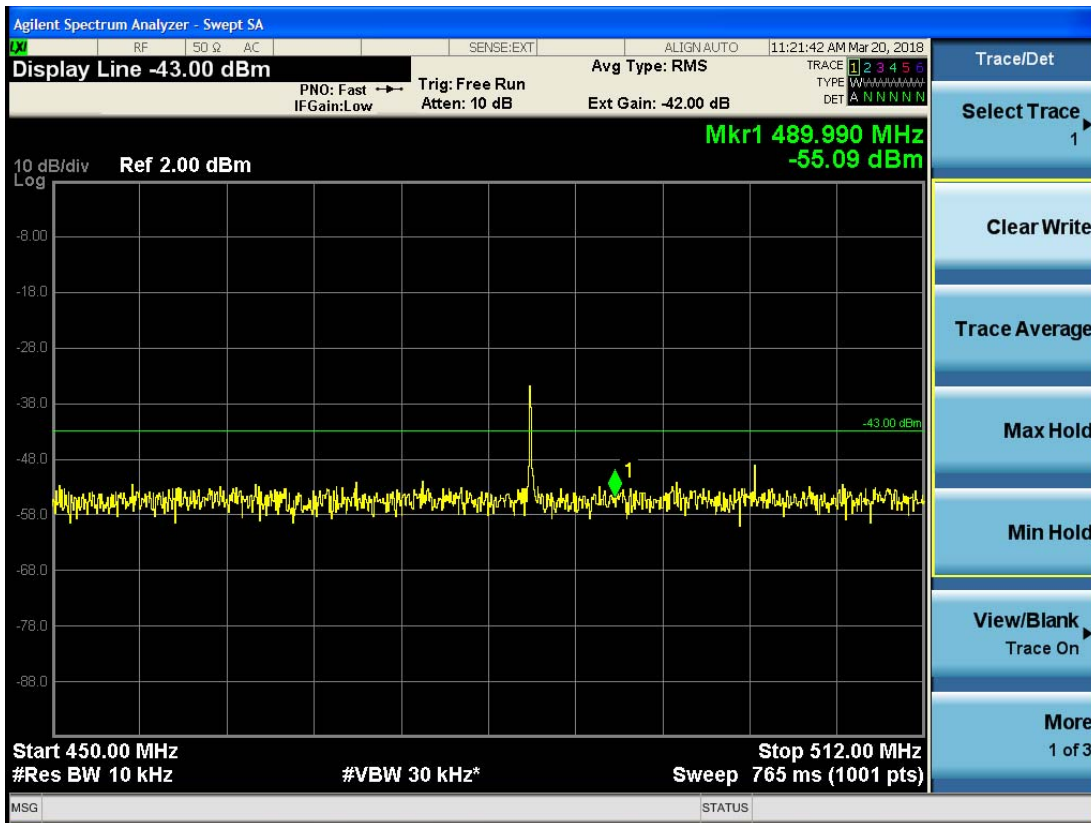

Out of band Amplifier noise: Please see the user manual for manufactures declaration on good engineering practice.

7.2.8 Radiated Spurious Emissions

Test Requirement: FCC part 90.219(e) (3)
(3) Spurious emissions from a signal booster must not exceed -13 dBm within any 100 kHz measurement bandwidth..

Test Method: FCC part 2.1053
TIA-603-E-2016

EUT Operation:

Status: Drive the EUT to maximum output power.

Conditions: Normal conditions

Application: Enclosure

Test Configuration:

9 kHz to 30 MHz emissions:

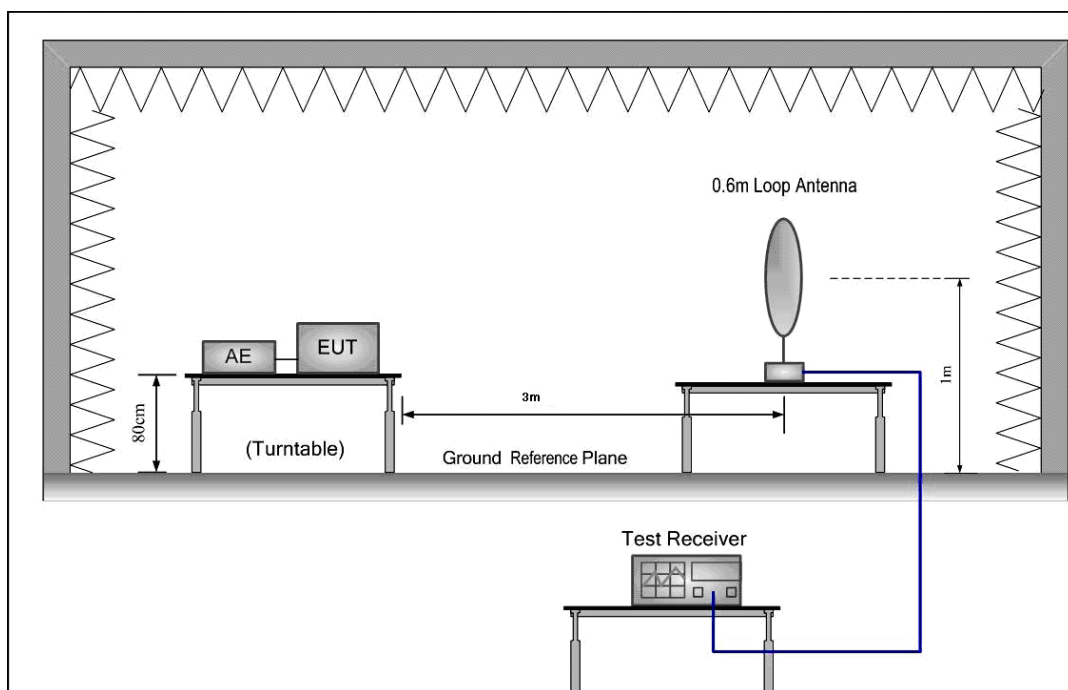

30MHz to 1GHz emissions:

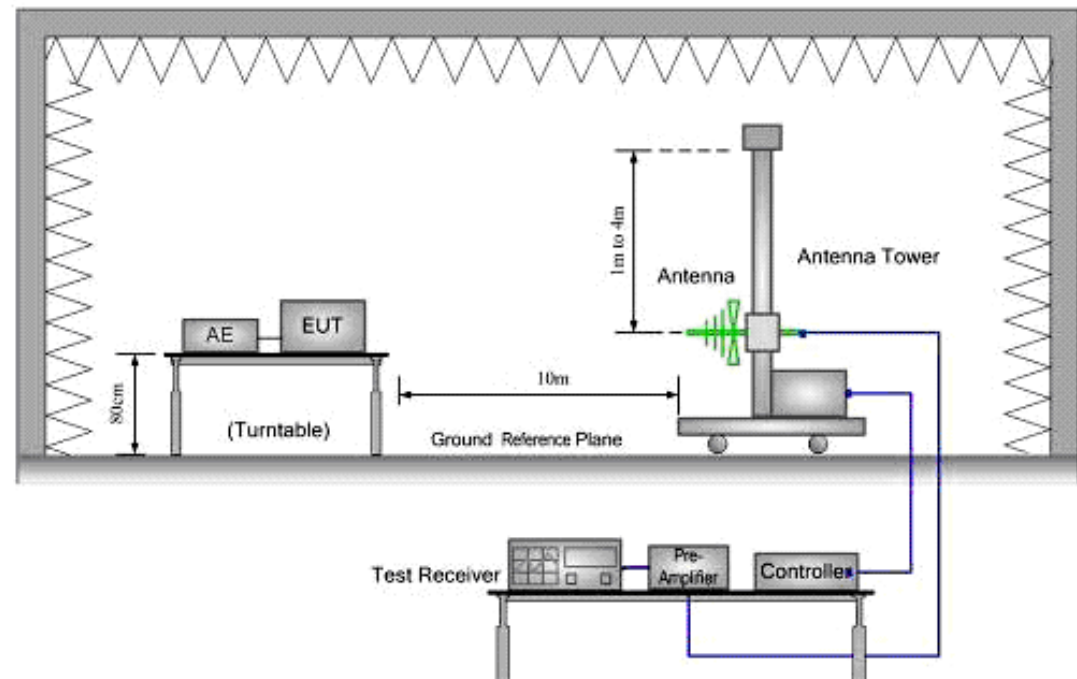

1GHz to 40GHz emissions:

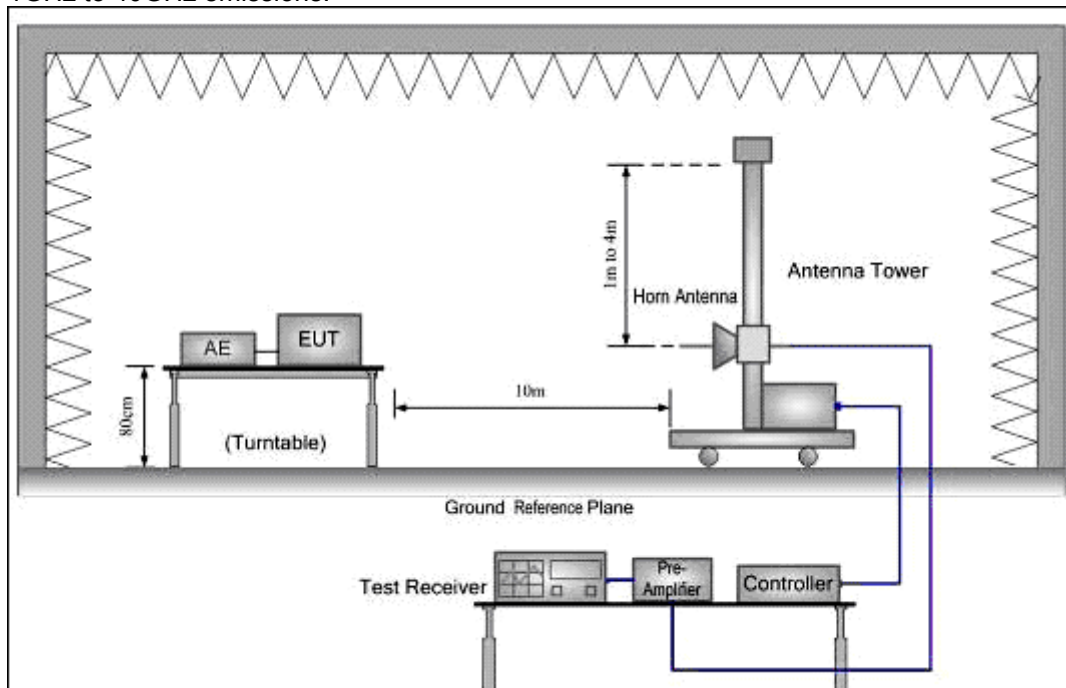

Test Procedure:

1. Test the background noise level with all the test facilities;
2. Keep one transmitting path, all other connectors shall be connected by normal power or RF leads;
3. Select the suitable RF notch filter to avoid the test receiver or spectrum

- analyzer produce unwanted spurious emissions;
- 4. Keep the EUT continuously transmitting in max power;
- 5. Read the radiated emissions of the EUT enclosure.

Radiated Emissions Test Procedure:

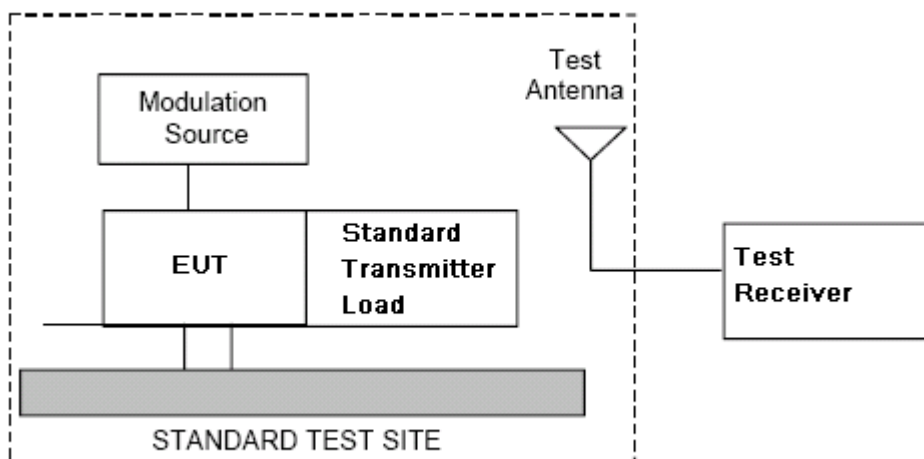

- a) Connect the equipment as illustrated.
- b) Adjust the spectrum analyzer for the following settings:
 - 1) Resolution Bandwidth = 100 kHz for spurious emissions below 1 GHz, and 1 MHz for spurious emissions above 1GHz.
 - 2) Video Bandwidth = 300 kHz for spurious emissions below 1 GHz, and 3 MHz for spurious emissions above 1 GHz.
 - 3) Sweep Speed slow enough to maintain measurement calibration.
 - 4) Detector Mode = Positive Peak.
- c) Place the transmitter to be tested on the turntable in the standard test site, The transmitter is transmitting into a nonradiating load that is placed on the turntable. The RF cable to this load should be of minimum length.
- d) Measurements shall be made from 30MHz to 10 times of fundamental carrier, except for the region close to the carrier equal to \pm the carrier bandwidth.
- e) Key the transmitter without modulation or normal modulation base the standard.
- f) For each spurious frequency, raise and lower the test antenna from 1 m to 4 m to obtain a maximum reading on the spectrum analyzer with the test antenna at horizontal polarity. Then the turntable should be rotated 360° to determine the maximum reading. Repeat this procedure to obtain the highest possible reading. Record this maximum reading.
- g) Repeat step f) for each spurious frequency with the test antenna polarized vertically.

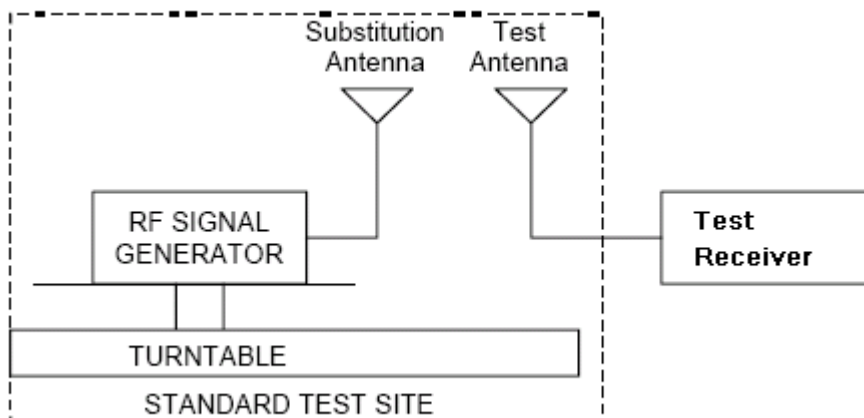

h) Reconnect the equipment as illustrated.

i) Keep the spectrum analyzer adjusted as in step b).

j) Remove the transmitter and replace it with a substitution antenna (the antenna should be half-wavelength for each frequency involved). The center of the substitution antenna should be approximately at the same location as the center of the transmitter. At the lower frequencies, where

the substitution antenna is very long, this will be impossible to achieve when the antenna is polarized vertically. In such case the lower end of the antenna should be 0.3 m above the ground.

k) Feed the substitution antenna at the transmitter end with a signal generator connected to the antenna by means of a nonradiating cable. With the antennas at both ends horizontally polarized, and with the signal generator tuned to a particular spurious frequency, raise and lower the test antenna to

obtain a maximum reading at the spectrum analyzer. Adjust the level of the signal generator output until the previously recorded maximum reading for this set of conditions is obtained. This should be done carefully repeating the adjustment of the test antenna and generator output.

l) Repeat step k) with both antennas vertically polarized for each spurious frequency.

m) Calculate power in dBm into a reference ideal half-wave dipole antenna by reducing the readings obtained in steps k) and l) by the power loss in the cable between the generator and the antenna, and further corrected for the gain of the substitution antenna used relative to an ideal half-wave dipole

antenna by the following formula:

$$P_d(\text{dBm}) = P_g(\text{dBm}) - \text{cable loss (dB)} + \text{antenna gain (dB)}$$

where:

P_d is the dipole equivalent power and

P_g is the generator output power into the substitution antenna.

NOTE: It is permissible to use other antennas provided they can be referenced to a dipole.

NOTE: Effective radiated power (e.r.p) refers to the radiation of a half wave tuned dipole instead of an isotropic antenna. There is a constant difference of 2.15 dB between e.i.r.p. and e.r.p.

$$\text{e.r.p (dBm)} = \text{e.i.r.p. (dBm)} - 2.15$$



7.2.8.1 Measurement Record: (need to change data)

No emissions were detected within 20dB below the limit for the Downlink direction.

Test Result:

9KHz~1000 MHz Field Strength of Unwanted Emissions. Peak Measurement

9KHz~1000 MHz Field Strength of Unwanted Emissions. Peak Measurement

The measurements with Loop and Log antennas were greater than 20dB below the limit, so the test data were only recorded one worst mode test graph in the test report.

Test at Frequency (481MHz) in transmitting status

30 MHz~1 GHz Spurious Emissions Peak Measurement

Vertical:

Peak scan

Level (dBμV/m)

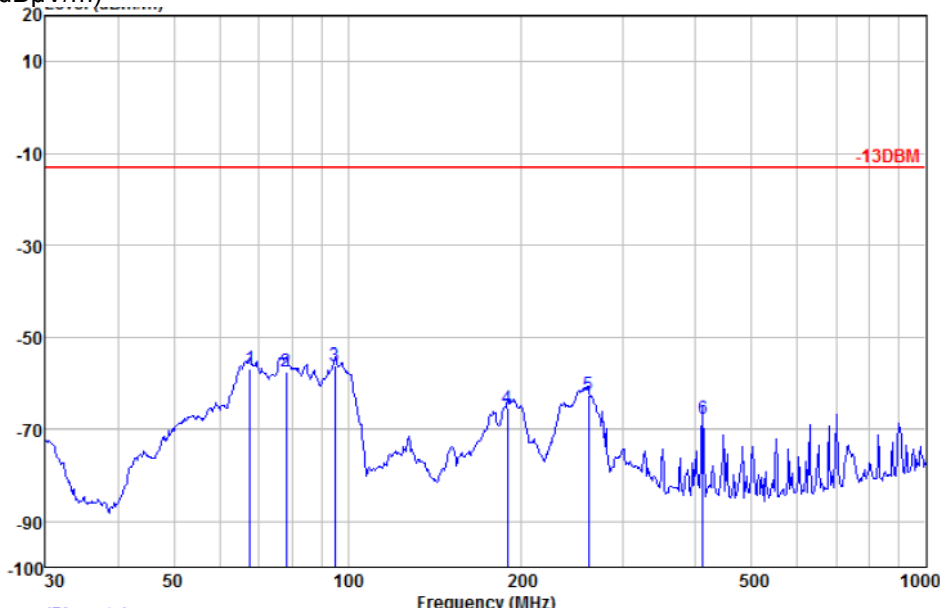

peak measurement

	Freq	Read Level	Antenna Factor	Cable Loss	Preamp Factor	Level	Limit Line	Over Limit	Pol/Phase
	MHz	dBm	dB/m	dB	dB	dBm	dBm	dB	
1	121.12	-68.89	-3.93	0.00	0.00	-72.82	-12.99	-59.83	VERTICAL
2	199.99	-61.54	-5.01	0.00	0.00	-66.55	-12.99	-53.56	VERTICAL
3	250.30	-54.35	-5.89	0.00	0.00	-60.24	-12.99	-47.25	VERTICAL

Horizontal:

Peak scan

Level (dB μ V/m)

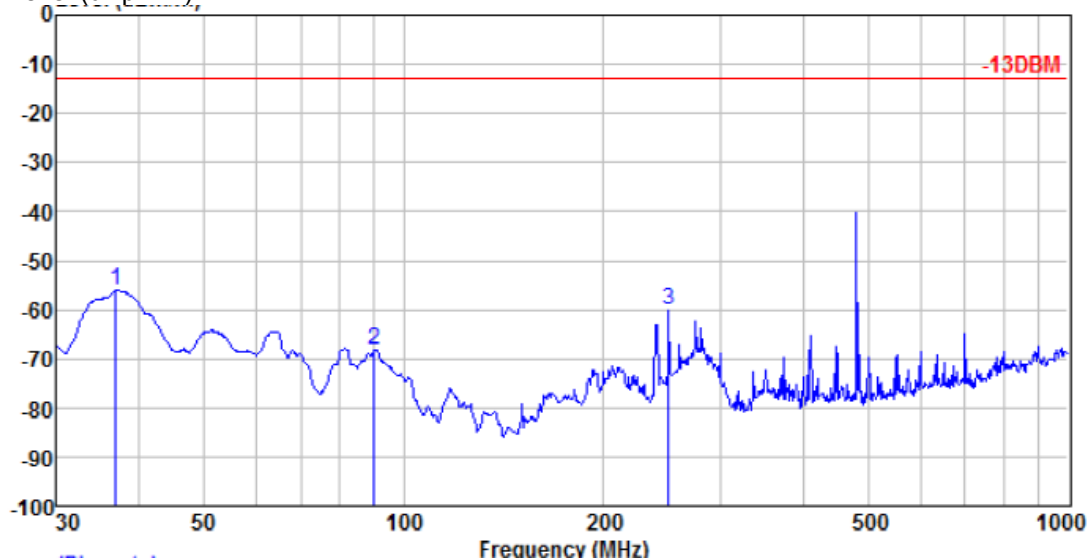

peak measurement

	Freq	Read Level	Antenna Factor	Cable Loss	Preamp Factor	Level	Limit Line	Over Limit	Pol/Phase
	MHz	dBm	dB/m	dB	dB	dBm	dBm	dB	
1	36.77	-58.68	2.56	0.00	0.00	-56.12	-12.99	-43.13	HORIZONTAL
2	90.22	-58.41	-9.79	0.00	0.00	-68.20	-12.99	-55.21	HORIZONTAL
3	250.30	-54.86	-5.40	0.00	0.00	-60.26	-12.99	-47.27	HORIZONTAL

30 MHz~1 GHz Spurious Emissions .Peak Measurement

DC:

Vertical:

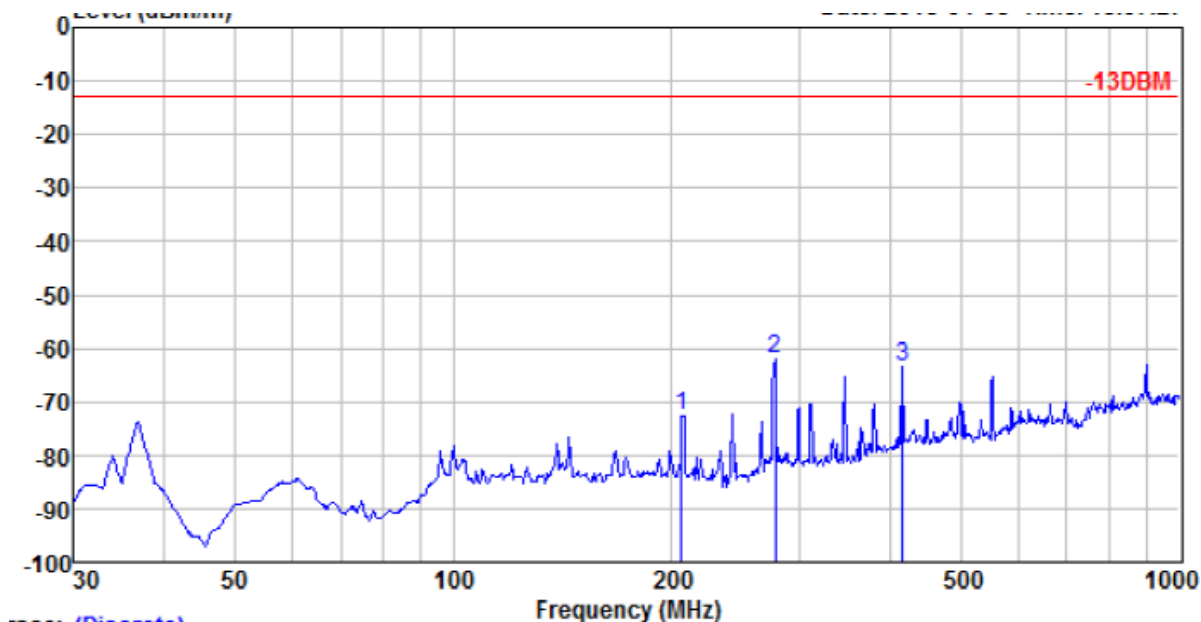

Peak scan

Level (dBμV/m)

peak measurement

	Freq	Read Level	Antenna Factor	Cable Loss	Preamp Factor	Level	Limit Line	Over Limit	Pol/Phase
	MHz	dBm	dB/m	dB	dB	dBm	dBm	dB	
1	206.40	-67.10	-5.45	0.00	0.00	-72.55	-12.99	-59.56	VERTICAL
2	277.09	-59.23	-2.88	0.00	0.00	-62.11	-12.99	-49.12	VERTICAL
3	416.18	-64.18	0.62	0.00	0.00	-63.56	-12.99	-50.57	VERTICAL

Horizontal:

Peak scan

Level (dB μ V/m)

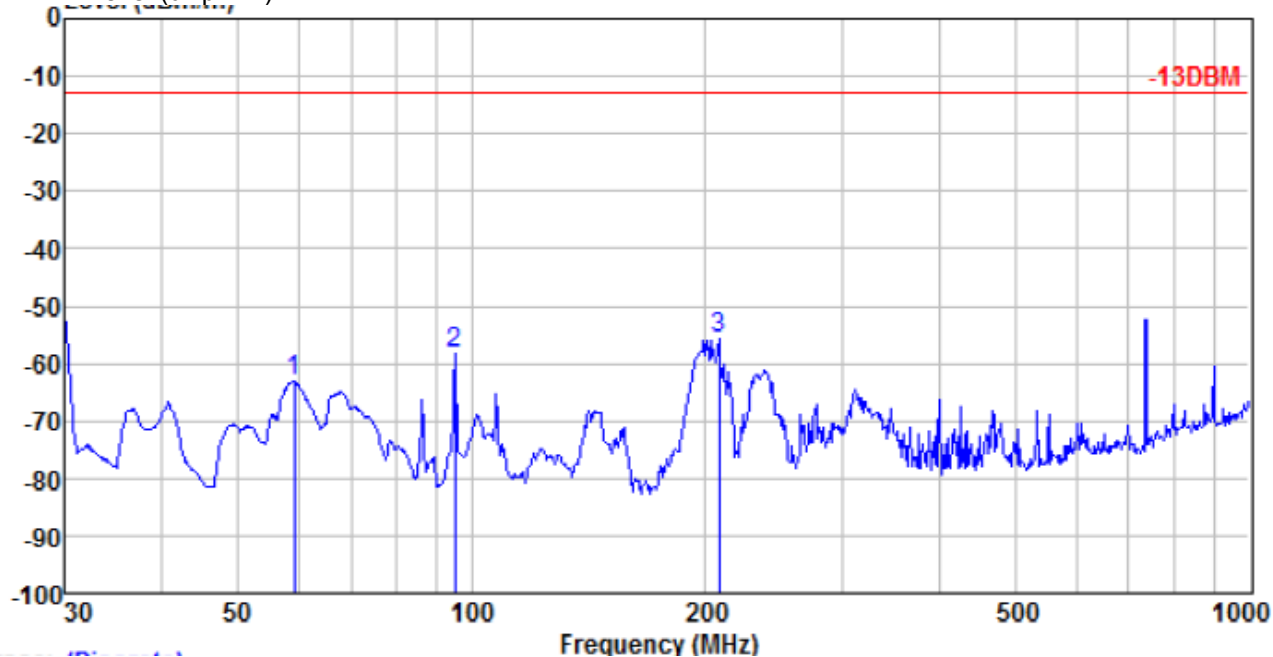

peak measurement

	Freq	Read Level	Antenna Factor	Cable Loss	Preamp Factor	Level	Limit Line	Over Limit	Pol/Phase
	MHz	dBm	dB/m	dB	dB	dBm	dBm	dB	
1	36.77	-58.68	2.56	0.00	0.00	-56.12	-12.99	-43.13	HORIZONTAL
2	90.22	-58.41	-9.79	0.00	0.00	-68.20	-12.99	-55.21	HORIZONTAL
3	250.30	-54.86	-5.40	0.00	0.00	-60.26	-12.99	-47.27	HORIZONTAL

For AC:

Above 1GHz Field Strength of Unwanted Emissions. Peak Measurement

Peak Measurement:

Frequency (MHz)	Antenna factors (dB/m)	Cable loss (dB)	Preamp factor (dB)	Reading Level (dBm)	Emission Level (dBm/m)	Limit (dBm/m)	Over limit (dB)	Antenna polarization
2415.019	9.6	0	0	-61.40	-51.8	-13.00	-38.80	Vertical
4239.921	4.29	0	0	-63.73	-59.44	-13.00	-46.44	V
6408.194	19.53	0	0	-64.59	-45.06	-13.00	-32.06	V
2156.063	9.33	0	0	-63.66	-54.33	-13.00	-41.33	Horizontal
2946.840	3.3	0	0	-63.64	-60.34	-13.00	-47.34	H
5958.479	18.06	0	0	-65.98	-47.92	-13.00	-34.92	H

For DC:

Above 1GHz Field Strength of Unwanted Emissions. Quasi-Peak Measurement

Peak Measurement:

Frequency (MHz)	Antenna factors (dB/m)	Cable loss (dB)	Preamp factor (dB)	Reading Level (dBm)	Emission Level (dBm/m)	Limit (dBm/m)	Over limit (dB)	Antenna polarization
2456.72	9.17	0	0	58.01	-48.84	-13.00	-35.84	Vertical
4914.59	9.63	0	0	-63.31	-53.68	-13.00	-40.68	V
6717.12	20.83	0	0	-65.22	-44.39	-13.00	-31.39	V
2021.99	9.82	0	0	-62.41	-52.59	-13.00	-39.59	Horizontal
2896.82	4.12	0	0	-61.79	-57.67	-13.00	-44.67	H
6380.82	19.40	0	0	-64.80	-45.40	-13.00	-32.40	H

Remark:

The cabinet radiation was measured with the equipment transmitting a CW signal into a non-radiating 50 Ohm load at maximum output power on a signal frequency .

Measured were performed in the lowest, middle and hightest frequency for the Downlink of products which included AC and DC Unit.

The spectrum was searched from 9KHz to 26GHz (10th Harmonic) for downlink;

7.2.9 Occupied Bandwidth

Test Requirement: KDB935210 D02;

Test Method: FCC part 2.1049

The spectral shape of the output should look similar to input for all modulations.

EUT Operation:

Status: Drive the EUT to maximum output power. the EUT was pretested at compression and 10dB into compression to show AGC operation, worse case results taken..

Conditions: Normal conditions

Application: Cellular Band RF output ports

Test Configuration:

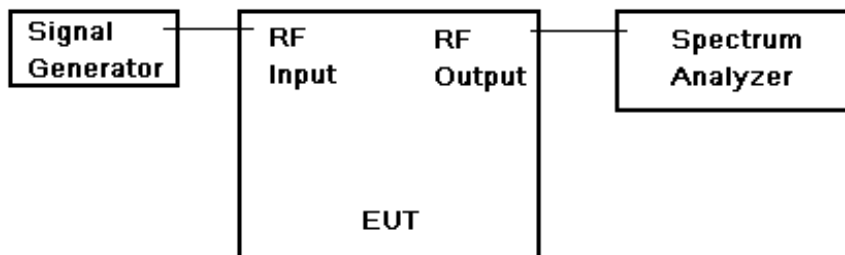

Fig.2. Conducted Spurious Emissions test configuration

Test Procedure:

- a) Set the spectrum analyzer RBW 300 Hz or $>1\%$ & $<2\%$ emission bandwidth of carrier.
- b) Capture the trace of input signal;
- c) Connect the equipment as illustrated;
- d) Capture the trace of output signal;

7.2.9.1 Measurement Record:

1. Downlink:450MHz to 509MHz
(for C4FM mode)

1.1 lowest frequency – Input

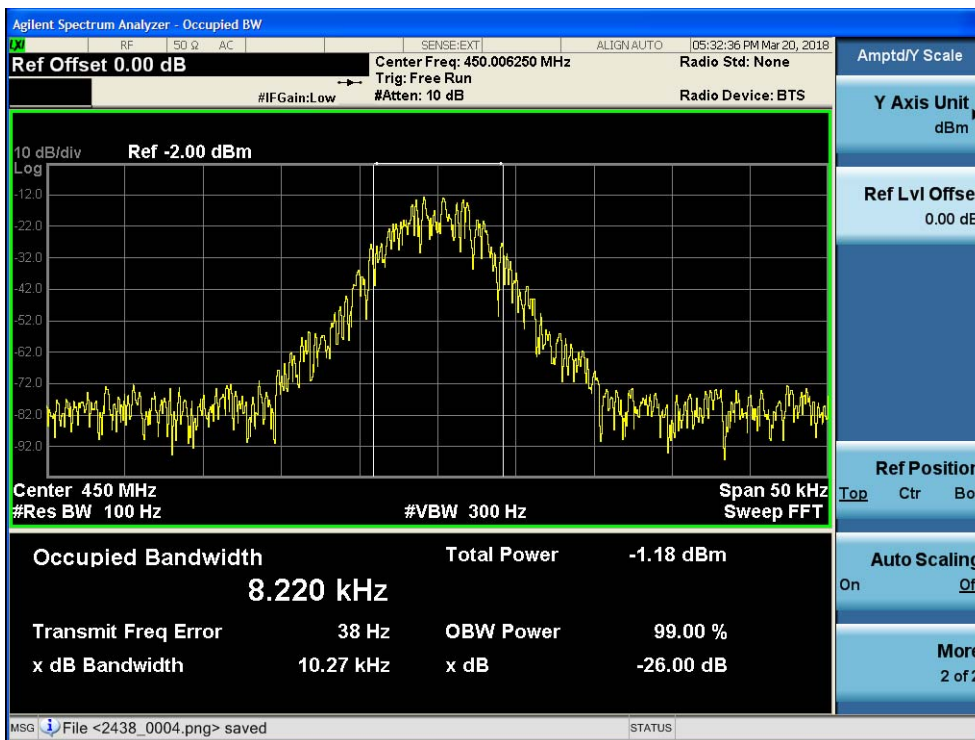

1.2 lowest frequency—Output

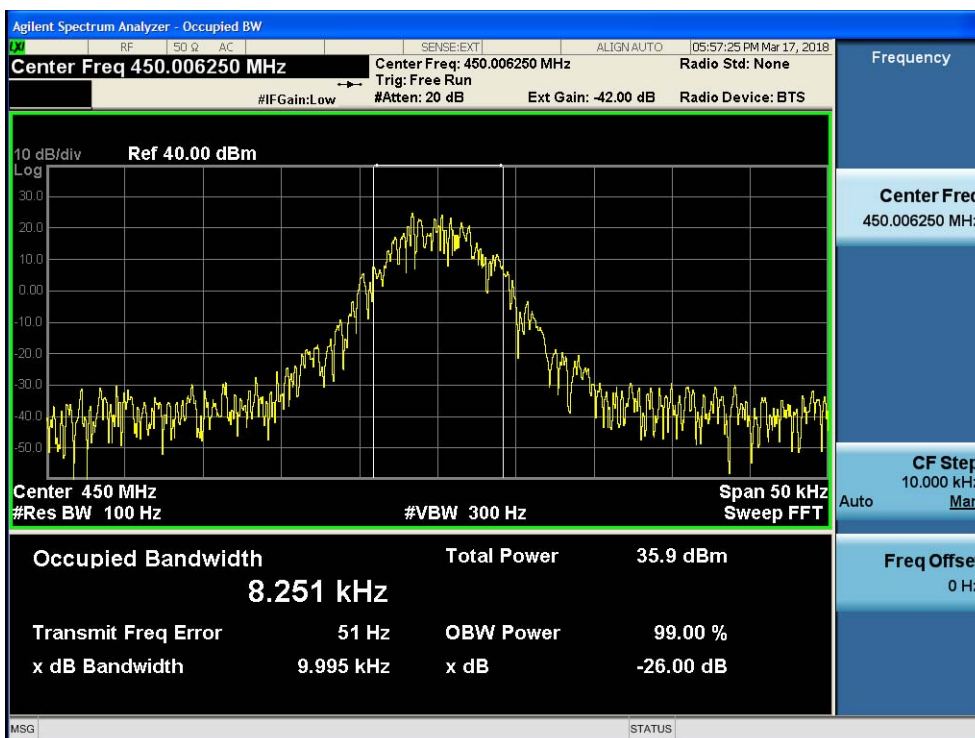

1.3 middle frequency—Input

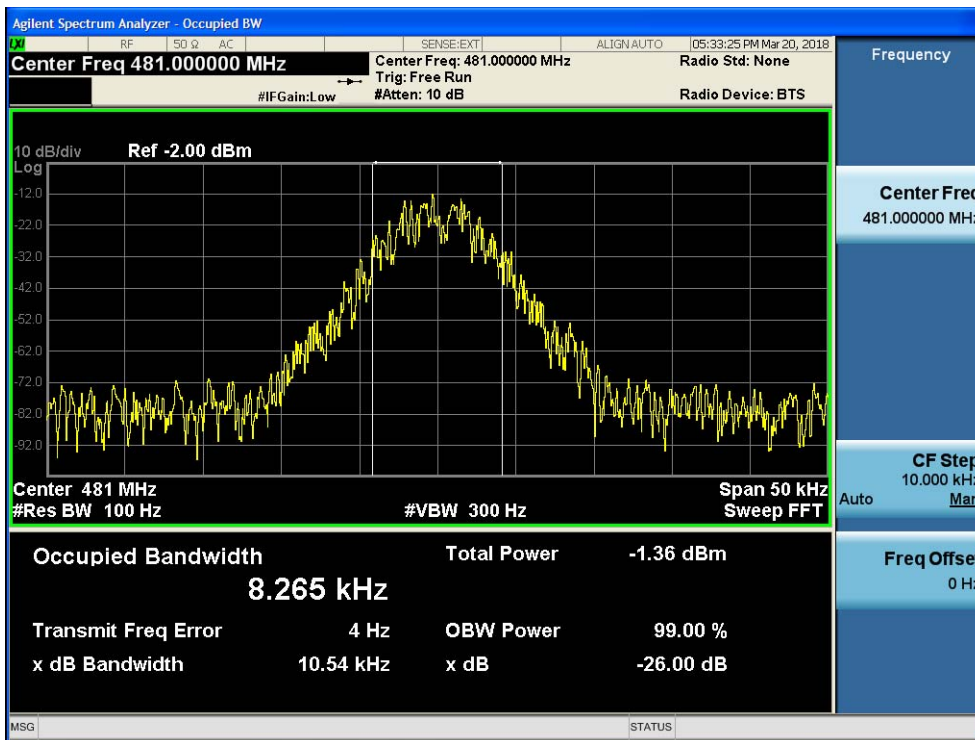

1.4 middle frequency—Output

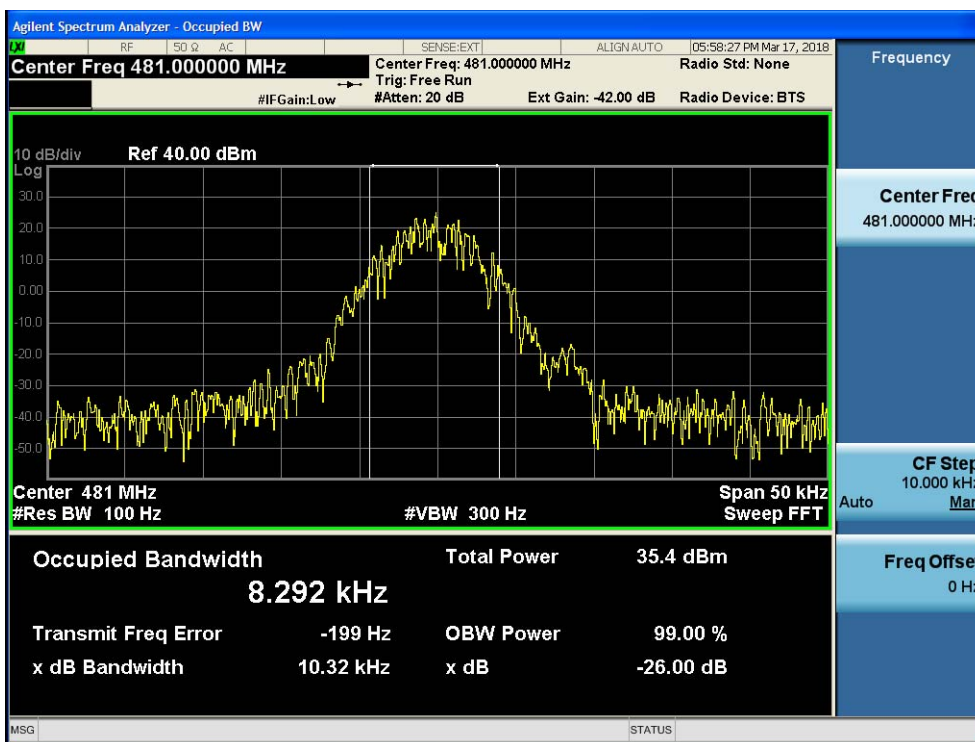

1.5 highest frequency—Input

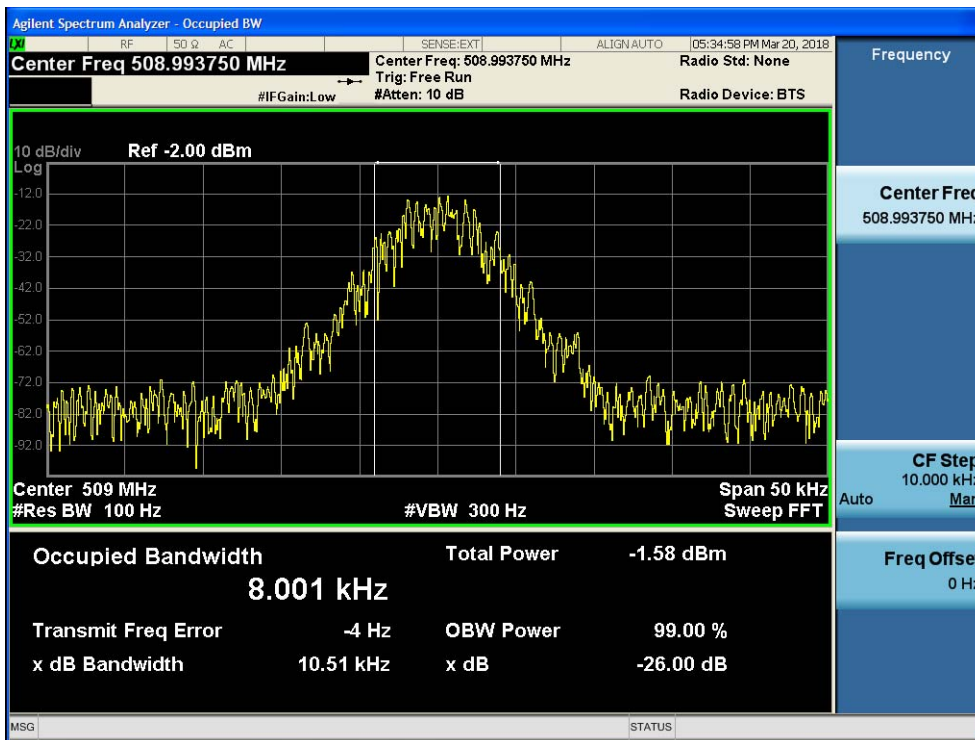

1.6 highest frequency—Output

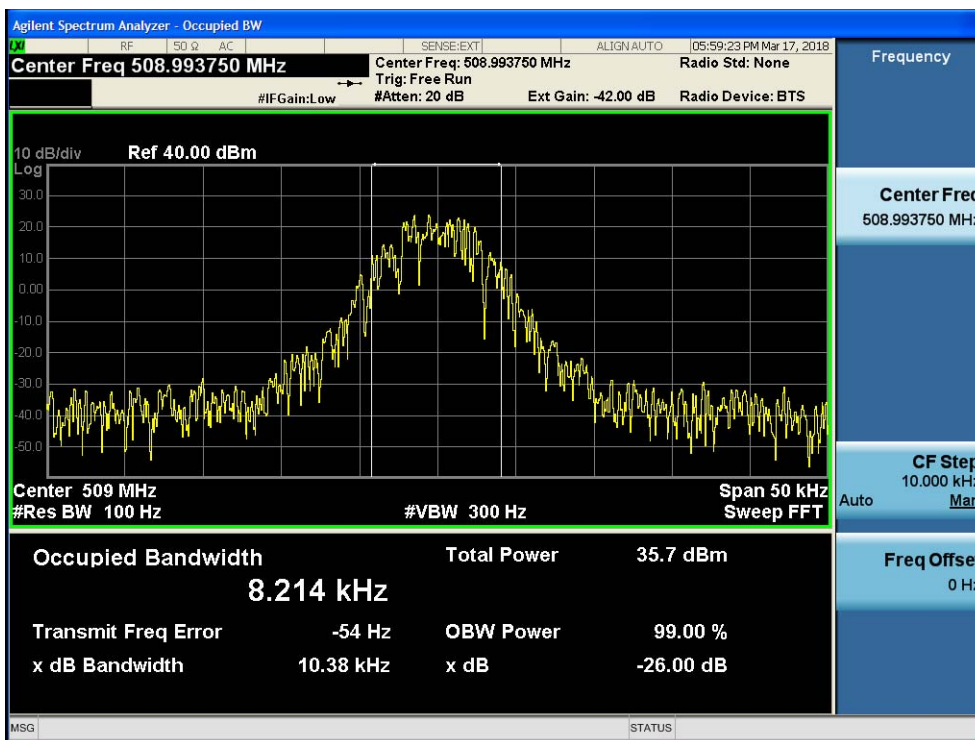

**2. Uplink:455MHz to 512MHz
(for C4FM mode)**

1.1 lowest frequency – Input

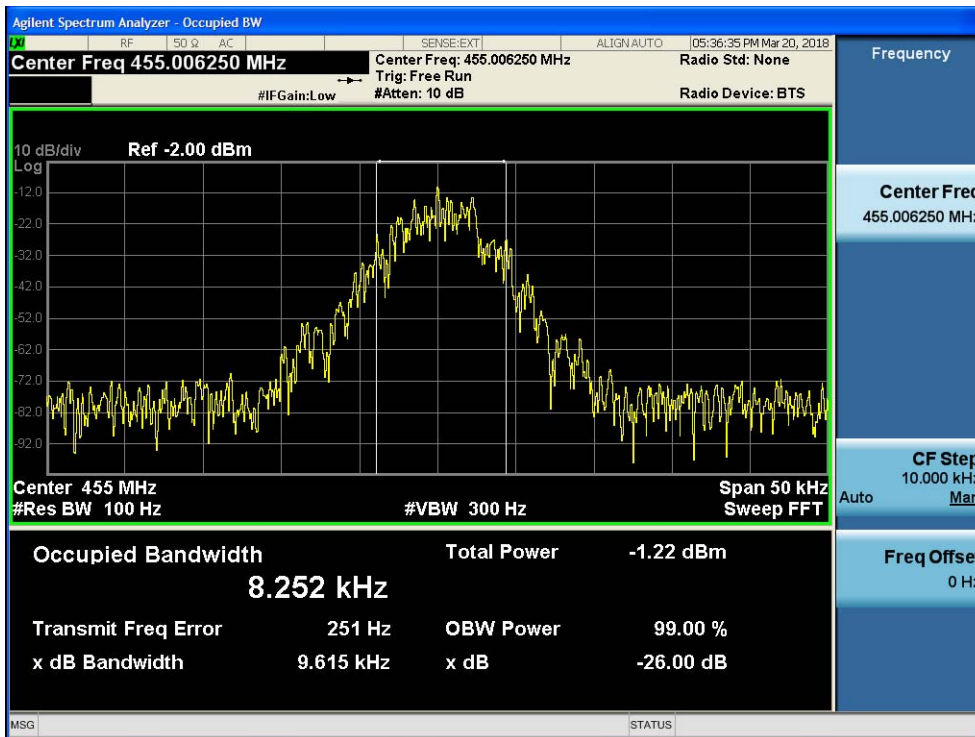

1.2 lowest frequency—Output

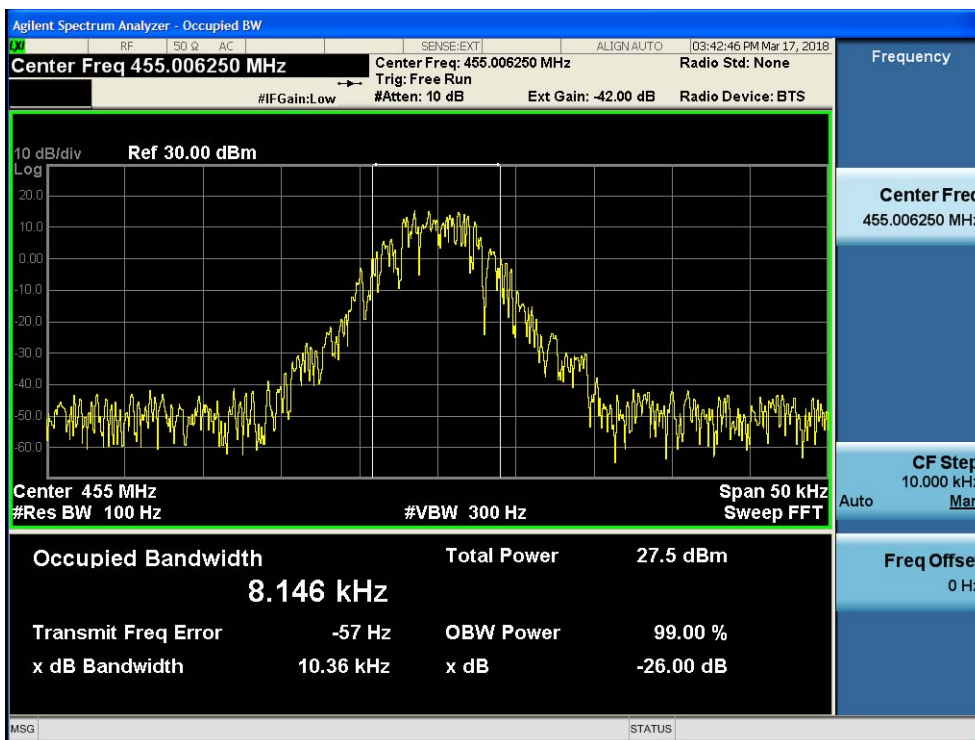

1.3 middle frequency—Input

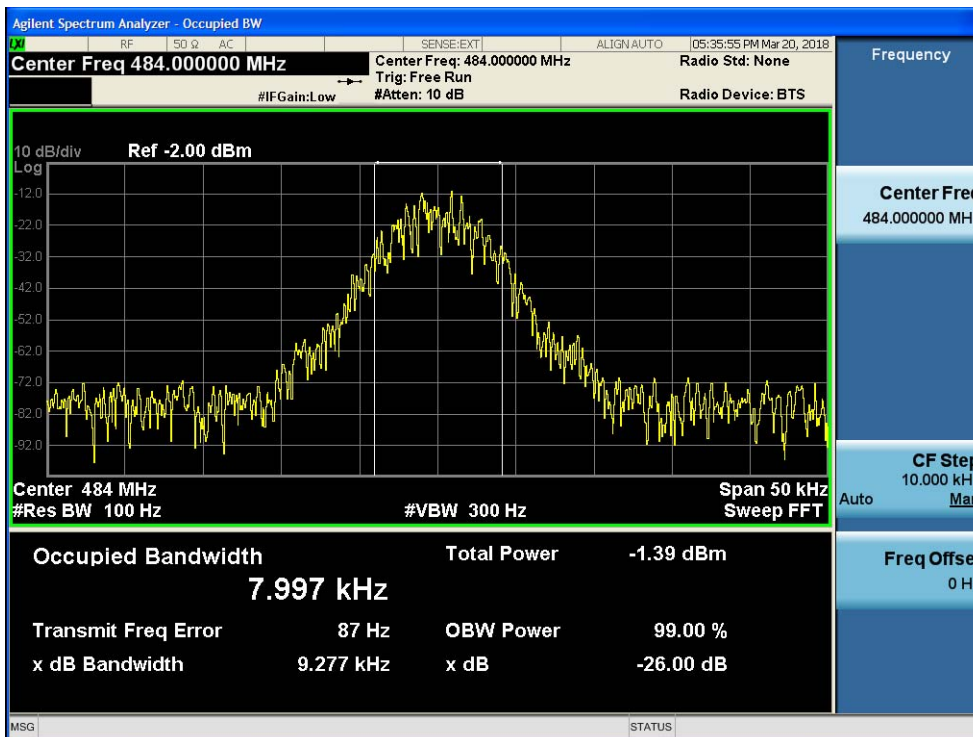

1.4 middle frequency—Output

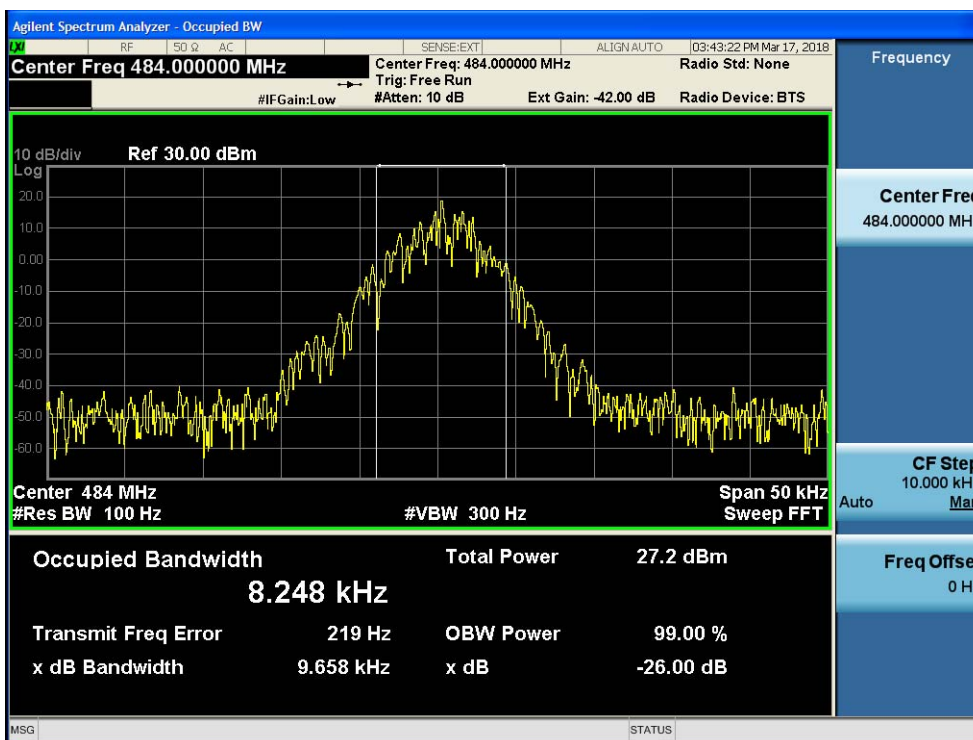

1.5 highest frequency—Input

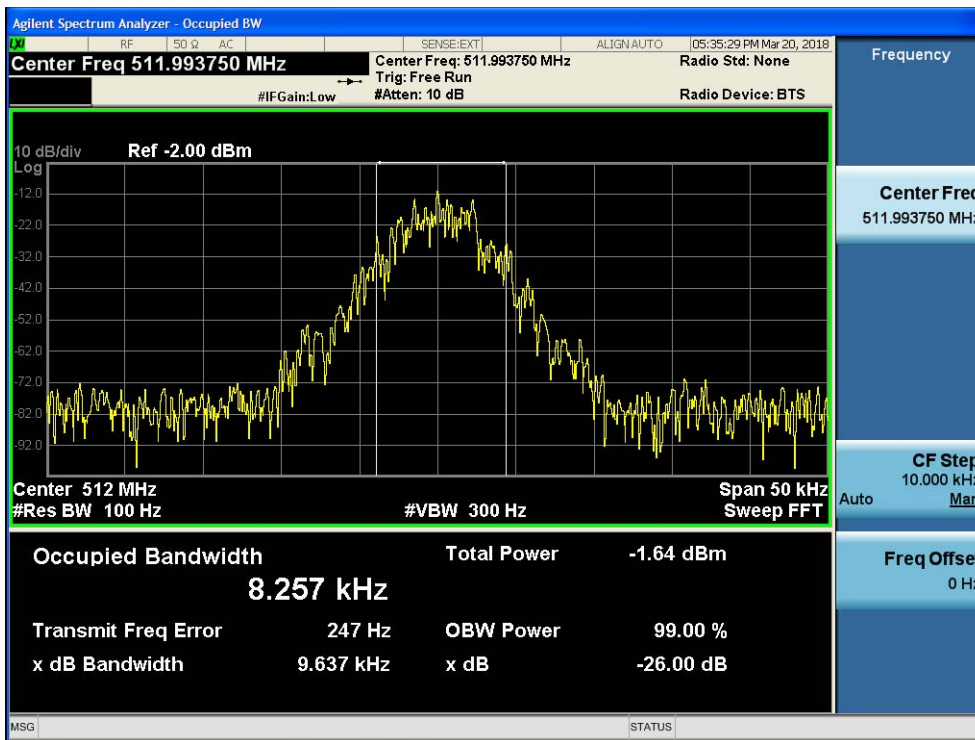

1.6 highest frequency—Output

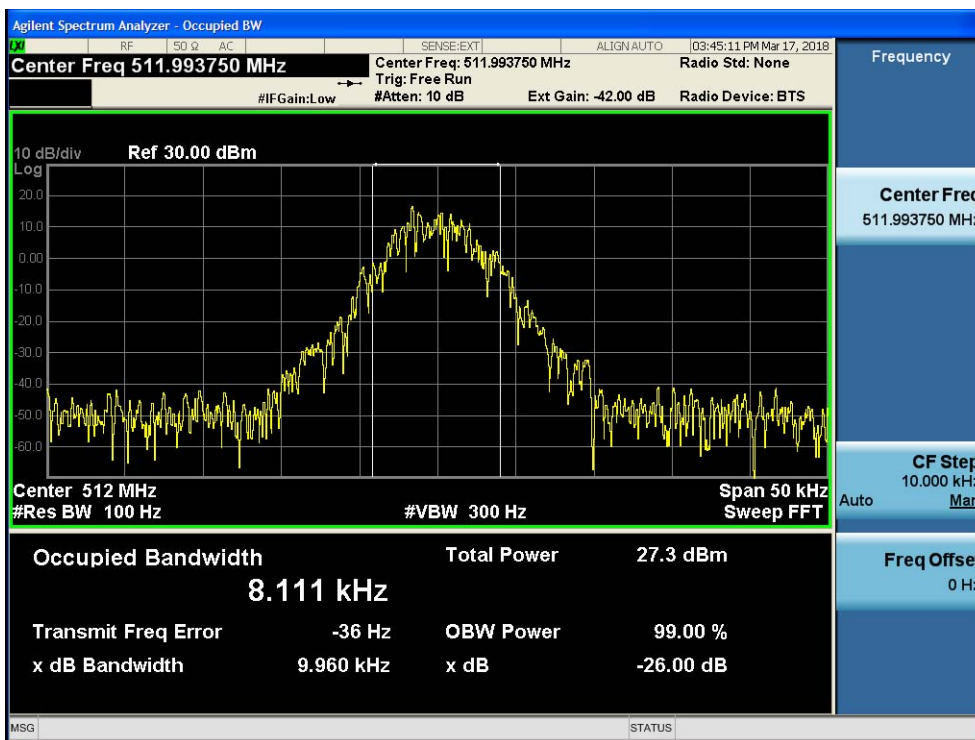

3. Downlink:450MHz to 509MHz (for FM 6.25K mode)

1.1 lowest frequency – Input

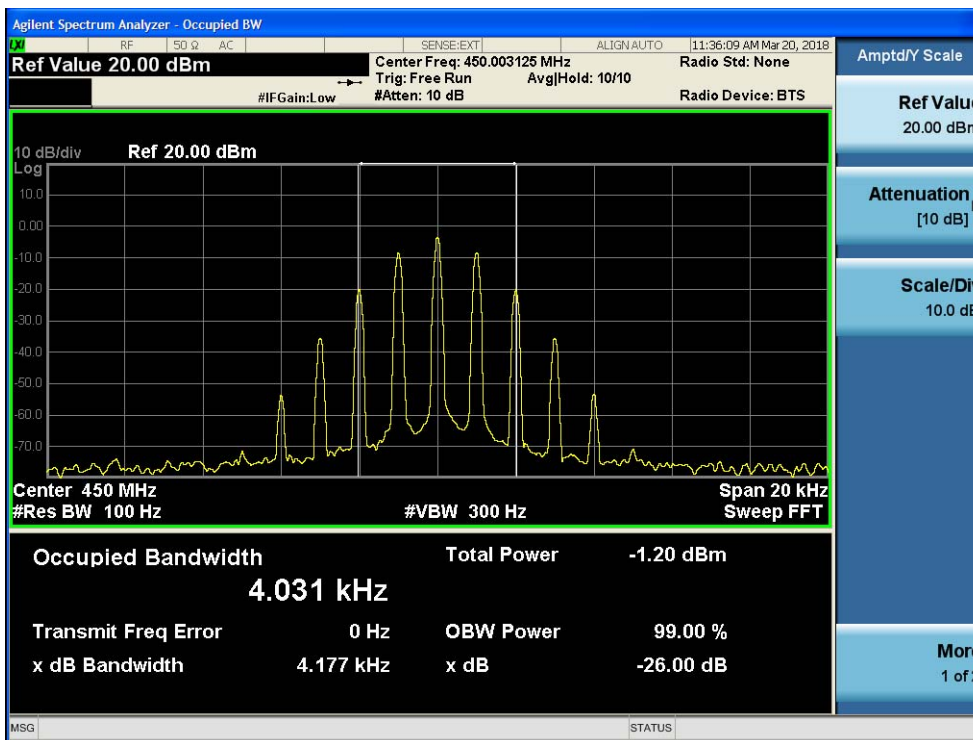

1.2 lowest frequency—Output

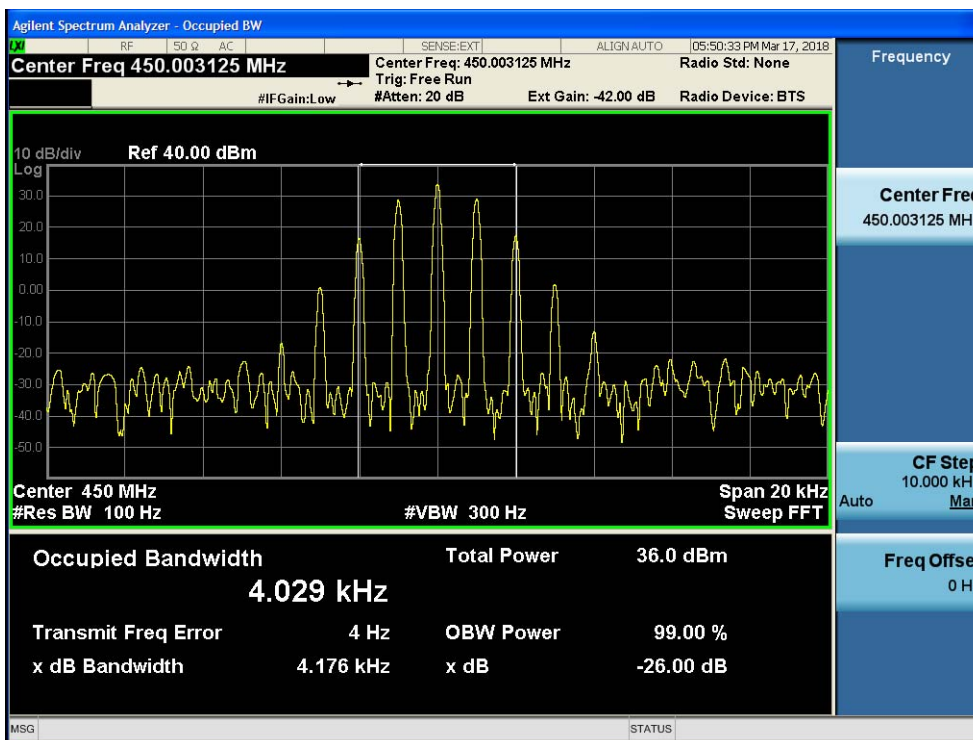

1.3 middle frequency—Input

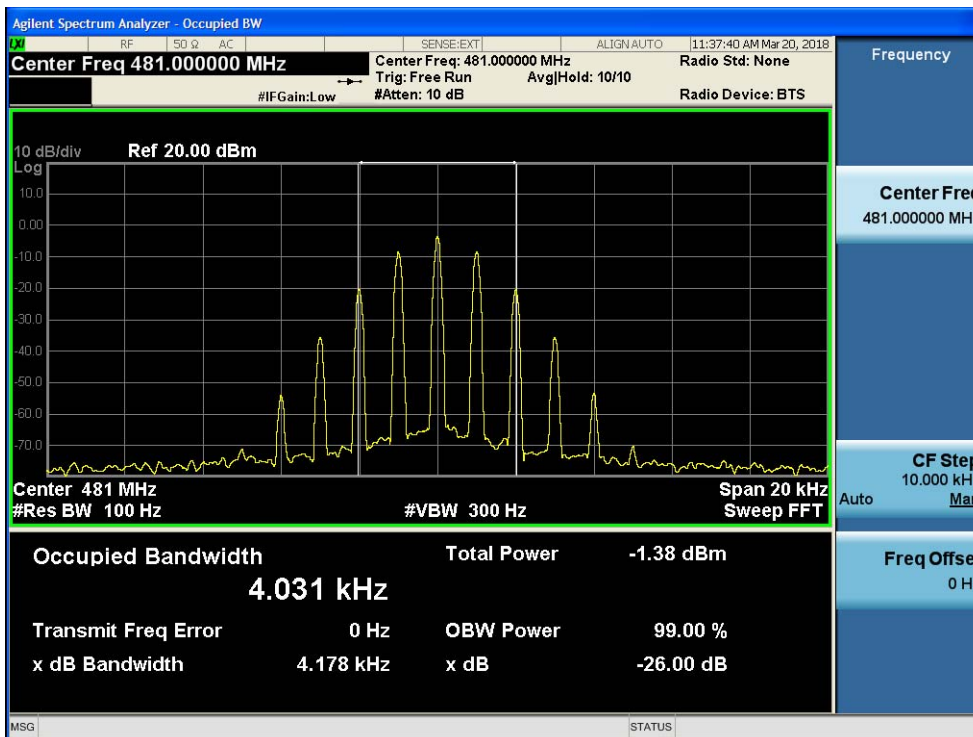

1.4 middle frequency—Output

