



**SGS-CSTC Standards Technical Services Co., Ltd.  
Shenzhen Branch**

198 Kezhu Road, Sciencetech Park, Guangzhou Economic & Technological  
Development District, Guangzhou, China 510663  
Telephone: +86 (0) 20 82155555  
Fax: +86 (0) 20 82075059  
Email: ee.guangzhou@sgs.com

Report No.: GZEM180300121601

Page: 1 of 118

FCC ID: PX8-RX4122-A

## **TEST REPORT**

<b>Application No.:</b>	GZEM1803001216CR
<b>Applicant:</b>	Comba Telecom Ltd.
<b>Product Description:</b>	UHF Public Safety Bi-directional Amplifier
<b>Model No.:</b>	RX4122-453236AC, RX4122-453236DC ♣
<b>♣</b>	Please refer to section 3 of this report for further details.
<b>Standards:</b>	FCC Part 2, FCC Part 90; KDB 935210 D02 Signal Booster Certificationv04
<b>FCC ID:</b>	PX8-RX4122-A
<b>Date of Test:</b>	2018-03-15 to 2018-03-27
<b>Date of Issue:</b>	2018-04-08
<b>Test Result :</b>	<b>Pass*</b>



Keny Xu

EMC Laboratory Manager

The manufacturer should ensure that all products in series production are in conformity with the product sample detailed in this report. If the product in this report is used in any configuration other than that detailed in the report, the manufacturer must ensure the new system complies with all relevant standards. Any mention of SGS International Electrical Approvals or testing done by SGS International Electrical Approvals in connection with, distribution or use of the product described in this report must be approved by SGS International Electrical Approvals in writing.

This document is issued by the Company subject to its General Conditions of Service printed overleaf, available on request or accessible at <http://www.sgs.com/en/Terms-and-Conditions.aspx> and, for electronic format documents, subject to Terms and Conditions for Electronic Documents at <http://www.sgs.com/en/Terms-and-Conditions/Terms-e-Document.aspx>. Attention is drawn to the limitation of liability, indemnification and jurisdiction issues defined therein. Any holder of this document is advised that information contained hereon reflects the Company's findings at the time of its intervention only and within the limits of Client's instructions, if any. The Company's sole responsibility is to its Client and this document does not exonerate parties to a transaction from exercising all their rights and obligations under the transaction documents. This document cannot be reproduced except in full, without prior written approval of the Company. Any unauthorized alteration, forgery or falsification of the content or appearance of this document is unlawful and offenders may be prosecuted to the fullest extent of the law. Unless otherwise stated the results shown in this test report refer only to the sample(s) tested and such sample(s) are retained for 30 days only.



## 2 Version

Revision Record				
Version	Chapter	Date	Modifier	Remark
00		2018-04-08		Original

Authorized for issue by:			
Tested By		2018-03-15 to 2018-03-27	
	Edison Li /Project Engineer	Date	
Checked By		2018-04-08	
	Eric Fu /Reviewer	Date	



### 3 Test Summary

Test Item	Test Requirement	Test Method	Result
Output Power	FCC part90.219e(1)	FCC part 2.1037	PASS
Conducted Spurious Emissions	FCC part90.219e(1)	KDB935210 D05v01r02	PASS
Emission mask	FCC part90.210	FCC part 2.1051	PASS
Band Edge& Intermodulation	FCC part90.219(e)(3)	KDB935210 D05v01r02	PASS
Noise figure	FCC part90.219(e)	KDB935210 D05v01r02	PASS
Noise at Antenna Terminals	FCC part 90.219(e)(2) 90.219(d)(6)(ii)	FCC part 2.1051	PASS
Radiated Spurious Emissions	FCC part90.219e(1)	KDB935210 D05v01r02	PASS
Occupied Bandwidth	FCC part 2.1049	KDB935210 D05v01r02	PASS
Out of Band Rejection	KDB935210 D05v01r02	KDB935210 D05v01r02	PASS
Frequency Stablility	FCC part90.213	FCC part 2.1055	PASS
<p><b>Remark:</b> Tx: In this whole report Tx (or tx) means Transmitter. Rx:In this whole report Rx (or rx) means Receiver.</p>			
<p>♣ <b>Model No:</b> RX4122-453236AC, RX4122-453236DC</p> <p>According to the confirmation from the applicant, the only difference between above four models is the power supply unit(PSU).</p> <p>RX4122-453236AC is with 100-240VAC power supply, while RX4122-453236DC is with -48VDC power supply. The electrical circuit design, RF modules used for above models are all identical, the output power and other RF specifications are the same.</p> <p>According to the above differences , the RX4122-453236AC was performed full tests and the new model RX4122-453236DC was tested the Radiated Emission test in this report.</p>			



## 4 Contents

	Page
<b>1 COVER PAGE .....</b>	<b>1</b>
<b>2 VERSION .....</b>	<b>2</b>
<b>3 TEST SUMMARY .....</b>	<b>3</b>
<b>4 CONTENTS .....</b>	<b>4</b>
<b>5 GENERAL INFORMATION .....</b>	<b>5</b>
5.1 CLIENT INFORMATION .....	5
5.2 GENERAL DESCRIPTION OF E.U.T. ....	5
5.3 DETAILS OF E.U.T. ....	5
5.4 PRODUCT DESCRIPTION .....	6
5.5 STANDARDS APPLICABLE FOR TESTING .....	6
5.6 TEST LOCATION .....	7
5.7 OTHER INFORMATION REQUESTED BY THE CUSTOMER .....	7
5.8 TEST FACILITY.....	8
<b>6 EQUIPMENT USED DURING TEST .....</b>	<b>9</b>
<b>7 TEST RESULTS .....</b>	<b>10</b>
7.1 E.U.T. TEST CONDITIONS .....	10
7.2 TEST PROCEDURE & MEASUREMENT DATA .....	12
7.2.1 AGC Threshold level.....	14
7.2.2 Conducted Output Power and Amplifier Gain .....	16
7.2.3 Conducted Spurious Emissions .....	19
7.2.4 Emission Mask.....	34
7.2.5 Intermodulation&Band edge .....	56
7.2.6 Noise Figure.....	64
7.3 HIGHEST FREQUENCY.....	69
7.2.7 Noise at Antenna Terminals.....	70
7.2.8 Radiated Spurious Emissions.....	74
7.2.9 Occupied Bandwidth.....	83
7.2.10 Out of Band Rejection.....	108
7.2.11 Frequency Stability.....	116



## 5 General Information

### 5.1 Client Information

Applicant Name: Comba Telecom Ltd.  
Applicant Address: 611 East Wing, 8 Science Park West Avenue, Hong Kong Science Park, Hong Kong  
Manufacturer: Comba Telecom Systems(China) Ltd.  
Address of Manufacturer: No.10 Shenzhou Road, Guangzhou Science City, Guangzhou 510663, Guangdong, P.R. China

### 5.2 General Description of E.U.T.

Test power: AC 120V 60Hz  
Operating Temperature: -33 °C to +60°C  
Operating Humidity: ≤ 95%

### 5.3 Details of E.U.T.

Type of Modulation C4FM & Analog FM  
Emission Designator: F1D, F1E, F3E  
Frequency Band: Downlink: 450MHz to 509MHz  
Uplink: 455MHz to 512MHz  
include the Modulation: C4FM, Analog FM  
Number of Channels 32  
Channel spacing 6.25kHz, 12.5kHz, 25kHz  
Nominal Power Output: 36dBm for downlink  
27dBm for uplink  
Nominal System Gain: 100dB



## 5.4 Product Description

The EUT is a Class A public Safety Bi-Directional Amplifier which is a wireless enhanced solution where high-quality voice or high-speed data service is not available between a mobile and a base station. BDA is ideal for the first phase of the network rollout and for any subsequent phase where cost, coverage, and quality need to be optimized.

BDA offers a modular, robust design that is easy to install, manage an upgrade. It supports three individually adjustable sub-bands for flexibility and high RF performance, supports multi-carrier and multi-band operation.

Remote configuration and surveillance is possible through Comba's remote and monitoring system via PC or wireless modem to the OMT/OMC.

## 5.5 Standards Applicable for Testing

The standard used was FCC part 2 & FCC part 90

According to the definition of KDB935210, the product named RX4122-453236AC, RX4122-453236DC belongs to the industrial Signal Booster.

### Definition of Industrial signal booster (Part 20)

#### KDB 935210 D02 Signal Booster Certification v04

**An Industrial Signal Booster (Part 20)** is any signal booster that is not a Consumer Signal Booster (Part 20) [i.e., CMRS parts 22, 24, 27, 90 (ESMR)].<sup>10</sup> [Section 20.3]

Industrial Signal Boosters are designed to serve multiple users simultaneously. [Order, ¶ 16 and fn 31]

Industrial Signal Boosters may be fixed-station equipment or mobile-station equipment, and are designed for installation by licensees or qualified installers. Unlike Consumer Signal Boosters, industrial signal boosters used in the CMRS bands are not distinguished as wideband or provider-specific. Part 90 Signal Boosters, other than Consumer Signal Boosters, are a type of Industrial Signal Booster—see also other specific part 90 terms and definitions below. [Order, ¶ 15]

#### Remark :

<sup>10</sup> Industrial Signal Boosters include large, high powered devices intended for professional or enterprise use. These devices tend to have more expansive functionality than Consumer Signal Boosters. For example, unlike Consumer Signal Boosters, many Industrial Signal Boosters incorporate remote monitoring capability to allow the operator to use a graphical user interface to control the device's functions, including remote power control, turn-on, and turn-off. The output power and gain for Industrial Signal Boosters are typically multiple times the power and gain of Consumer Signal Boosters. These devices are designed to serve multiple users simultaneously and cover larger areas such as stadiums, shopping malls, office buildings, tunnels, and campuses. An Industrial Signal Booster installation may support a single wireless provider or multiple wireless providers. In addition, such an installation may utilize a greater number of antennas, amplifiers, and other components, compared to Consumer Signal Boosters. [Order, ¶ 16]



## 5.6 Test Location

All tests were performed at:

SGS-CSTC Standards Technical Services Co., Ltd. Shenzhen Branch E&E Lab

No. 1 Workshop, M-10, Middle section, Science & Technology Park, Shenzhen, Guangdong, China  
518057

No tests were sub-contracted.

## 5.7 Other Information Requested by the Customer

None.

## 5.8 Test Facility

The test facility is recognized, certified, or accredited by the following organizations:

- **CNAS (No. CNAS L2929)**

CNAS has accredited SGS-CSTC Standards Technical Services Co., Ltd. Shenzhen Branch EMC Lab to ISO/IEC 17025:2005 General Requirements for the Competence of Testing and Calibration Laboratories (CNAS-CL01 Accreditation Criteria for the Competence of Testing and Calibration Laboratories) for the competence in the field of testing.

- **A2LA (Certificate No. 3816.01)**

SGS-CSTC Standards Technical Services Co., Ltd., Shenzhen EMC Laboratory is accredited by the American Association for Laboratory Accreditation(A2LA). Certificate No. 3816.01.

- **VCCI**

The 3m Fully-anechoic chamber for above 1GHz, 10m Semi-anechoic chamber for below 1GHz, Shielded Room for Mains Port Conducted Interference Measurement and Telecommunication Port Conducted Interference Measurement of SGS-CSTC Standards Technical Services Co., Ltd. have been registered in accordance with the Regulations for Voluntary Control Measures with Registration No.: G-20026, R-14188, C-12383 and T-11153 respectively.

- **FCC –Designation Number: CN1178**

SGS-CSTC Standards Technical Services Co., Ltd., Shenzhen EMC Laboratory has been recognized as an accredited testing laboratory.

Designation Number: CN1178. Test Firm Registration Number: 406779.

- **Industry Canada (IC)**

Two 3m Semi-anechoic chambers and the 10m Semi-anechoic chamber of SGS-CSTC Standards Technical Services Co., Ltd. Shenzhen Branch EMC Lab have been registered by Certification and Engineering Bureau of Industry Canada for radio equipment testing with Registration No.: 4620C-1, 4620C-2, 4620C-3.



## 6 Equipment Used during Test

RF conducted test						
Item	Test Equipment	Manufacturer	Model No.	Inventory No.	Cal. Date (yyyy-mm-dd)	Cal. Due date (yyyy-mm-dd)
1	DC Power Supply	ZhaoXin	PS-3005D	SEM011-05	2017-09-27	2018-09-26
2	Spectrum Analyzer (20Hz-43GHz)	Rohde & Schwarz	F5U43	SEM004-08	2018-04-13	2019-04-12
3	Signal Generator (9kHz-40GHz)	KEYSIGHT	N5173B	SEM006-05	2017-09-27	2018-09-26
4	Measurement Software	JS Tonscend	JS1120-2 BT/WIFI V2.6	N/A	N/A	N/A
5	Coaxial Cable	SGS	N/A	SEM031-01	2017-07-13	2018-07-12
6	Attenuator	Weinschel Associates	WA41	SEM021-09	N/A	N/A

RE in Chamber						
Item	Test Equipment	Manufacturer	Model No.	Inventory No.	Cal. Date (yyyy-mm-dd)	Cal. Due date (yyyy-mm-dd)
1	3m Semi-Anechoic Chamber	ETS-LINDGREN	N/A	SEM001-01	2017-08-05	2020-08-04
2	MXE EMI Receiver (20Hz-8.4GHz)	Agilent Technologies	N9038A	SEM004-05	2017-09-27	2018-09-26
3	BiConiLog Antenna (26-3000MHz)	ETS-LINDGREN	3142C	SEM003-01	2017-06-27	2020-06-26
4	Pre-amplifier (0.1-1300MHz)	Agilent Technologies	8447D	SEM005-01	2018-04-02	2019-04-01
5	Measurement Software	AUDIX	e3 V8.2014-6-27	N/A	N/A	N/A
6	Coaxial Cable	SGS	N/A	SEM025-01	2017-07-13	2018-07-12

General used equipment						
Item	Test Equipment	Manufacturer	Model No.	Inventory No.	Cal. Date (yyyy-mm-dd)	Cal. Due date (yyyy-mm-dd)
1	Humidity/ Temperature Indicator	Shanghai Meteorological Industry Factory	ZJ1-2B	SEM002-03	2017-09-29	2018-09-28
2	Humidity/ Temperature Indicator	Shanghai Meteorological Industry Factory	ZJ1-2B	SEM002-04	2017-09-29	2018-09-28
3	Humidity/ Temperature Indicator	Mingle	N/A	SEM002-08	2017-09-29	2018-09-28
4	Barometer	Changchun Meteorological Industry Factory	DYM3	SEM002-01	2018-04-08	2019-04-07

## 7 Test Results

### 7.1 E.U.T. test conditions

Input Voltage: AC 120V

Operating Environment:

Temperature: 22°C ~26°C

Humidity: 37%~56% RH

Atmospheric Pressure: 990~1005mbar

Test Requirement: The RF output power of the EUT was measured at the antenna port, by adjusting the input power of signal generator to drive the EUT to get to maximum output power point and keep the EUT at maximum gain setting for all tests. The device should be tested on downlink.

For detail test Modulation and Frequency, please refer to 7.2.

#### Remark:

*Synonyms and related terms: in-building radiation system, coverage enhancer, distributed antenna system, fiber-optic distribution system, converter, donor antenna*

Typical in-building or distributed antenna systems can consist of five different components (enclosures), not counting antennas:

#### 1) host unit

- a) transmits uplink to base station via antenna thru coax, **passive interface unit**, or **active interface unit** (amplifier)
- b) sends base-station downlink via fiber-optic or coax to **remote**
- c) receives handset uplink via fiber-optic or coax from **remote**
- d) optional connection to **expansion unit** via fiber-optic
- e) separate FCC ID from **remote**, unless electrically identical
- f) **non-transmitting host unit**
- i) connects directly to a base station via coax cable but does not connect to antenna or amplifier
- ii) Part 15 digital device subject to Verification, no FCC ID

#### 2) remote unit

- a) receives base-station downlink via fiber-optic or coax from **host**, transmits via antenna to handsets
- b) returns handset uplink via fiber-optic or coax to **host**
- c) separate FCC ID from **remote**, unless electrically identical

#### 3) expansion unit

- a) fiber-optic or coax from **host**
- b) fiber-optic or coax fan-out to **remote(s)**
- c) Part 15 digital device subject to Verification, no FCC ID

#### 4) passive interface unit

- a) contains attenuators, splitters, combiners
- b) coax cable connection between **host** and base-station
- c) passive device, no FCC ID

#### 5) active interface unit

- a) amplifies uplink signal from **host unit** for transmit by donor antenna
- b) attenuates downlink from donor antenna
- c) coax cable connection between **host** and **active interface unit**
- d) usually has separate FCC ID; in some cases could be combined/included with **host** as



---

one enclosure

**GENERAL DEFINITIONS FOR CERTIFICATION PURPOSES:**

The following three general definitions follow from those stated in the Part 22, 24, and 90 rule sections as listed above. Two of the definitions replace previous EAB internal definitions given for booster, repeater and extender. The general term “extender” is the same as booster, but booster should be used rather than extender. The general term “translator” is the same as repeater, but repeater should be used rather than translator.

**External radio frequency power amplifier (ERFPA)** - any device which, (1) when used in conjunction with a radio transmitter signal source, is capable of amplification of that signal, and (2) is not an integral part of a radio transmitter as manufactured. The EAS equipment class AMP is used only for an ERFPA device inserted between a transmitter (TNB/PCB) and an antenna (has only one antenna port)

**Booster** is a device that automatically reradiates signals from base transmitters without channel translation, for the purpose of improving the reliability of existing service by increasing the signal strength in dead spots. An “in-building radiation system” is a signal booster. These devices are not intended to extend the size of coverage from the originating base station. A booster can be either single or multiple channels.

**Repeater** is a device that retransmits the signals of other stations. Repeaters are different from boosters in that they can include frequency translation and can extend coverage beyond the design of the original base station. A repeater is typically single channel but can also be multiple channels.

ERFPA (AMP) and boosters/repeaters (TNB/PCB) can generally be authorized for all rule parts except 15 and 18.

Tests should be done with each typical signal. e.g., for F3E emissions use 2500 Hz with 2.5 or 5 kHz deviation. Use of CW signal for some tests is acceptable in lieu of actual emission, in some cases when CW signal gives worst case.

**So the Equipment belongs to the repeater.**



## 7.2 Test Procedure & Measurement Data

### Test Modulation and Frequency

Downlink: 450MHz to 509MHz

Modulation	Lowest frequency	Middle frequency	Highest frequency
C4FM(12.5k)	450.00625	481	508.99375
FM(6.25k)	450.003125	481	508.996875
FM(12.5k)	450.00625	481	508.99375
FM(25k)	450.0125	481	508.9875

Uplink: 455MHz to 512MHz

Modulation	Lowest frequency	Middle frequency	Highest frequency
C4FM(12.5k)	455.00625	484	511.99375
FM(6.25k)	455.003125	484	511.996875
FM(12.5k)	455.00625	484	511.99375
FM(25k)	455.0125	484	511.9875

### Remark:

- 1) We test the downlink in the lowest band; the middle band; the highest band and test the respective frequency as above table;

General Test Setup:

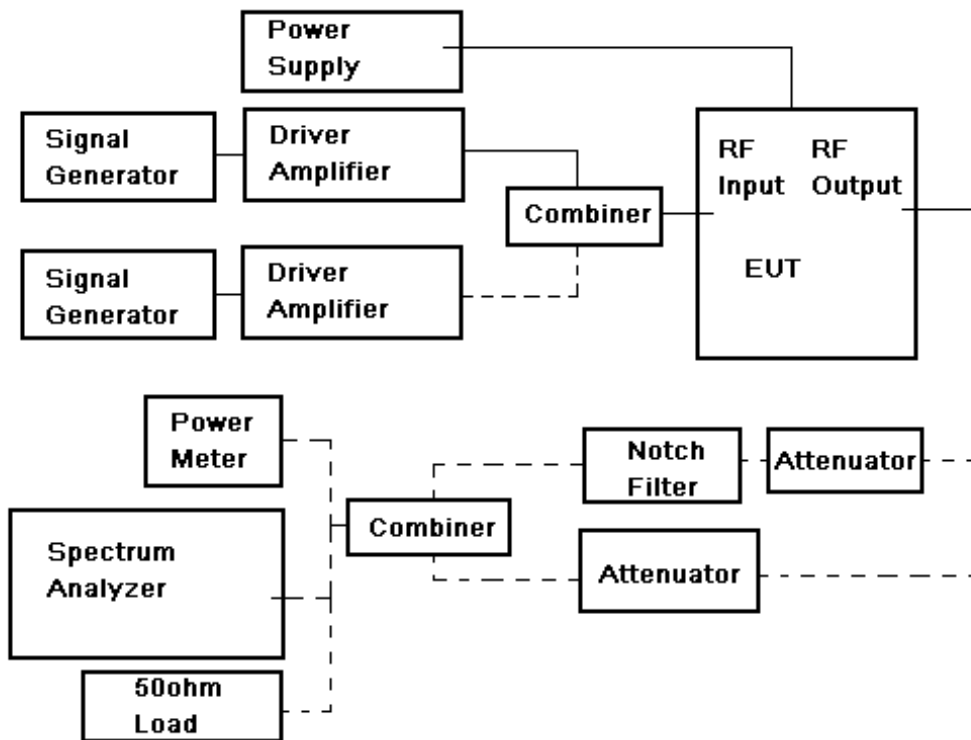

### 7.2.1 AGC Threshold level

Test Method: KDB935210 D05

Test Requirement: Not specified

EUT Operation:

Status: Drive the EUT to maximum output power. Pretest was performed in both channels, only kept the final measurement data of worse case.

Conditions: Normal conditions

Application: Cellular Band RF output ports

Test Configuration:

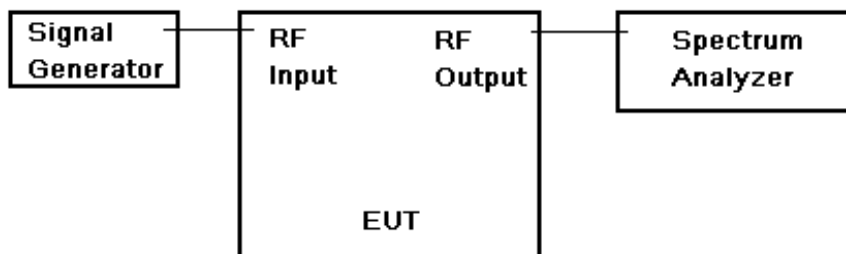

AGC threshold test configuration

Test Procedure:

- a) Connect a signal generator to the input of the EUT.
- b) Connect a spectrum analyzer or power meter to the output of the EUT using appropriate attenuation as necessary.
- c) The signal generator should initially be configured to produce either of the required test signals (i.e., broadband or narrowband).
- d) Set the signal generator frequency to the center frequency of the EUT operating band.
- e) While monitoring the output power of the EUT, measured using the methods of 3.5.3 or 3.5.4, increase the input level until a 1 dB increase in the input signal power no longer causes a 1 dB increase in the output signal power.
- f) Record this level as the AGC threshold level.
- g) Repeat the procedure with the remaining test signal.



**7.2.1.1 Measurement Record:**

Downlink: 450MHz ~ 509MHz

Test items	Modulation	Carrier frequency(MHz)	Level(dBm)
AGC Threshold	C4FM	450.00625	-64.3
AGC Threshold	C4FM	481	-64.8
AGC Threshold	C4FM	508.99735	-64.5
AGC Threshold	FM(6.25k)	450.003125	-64.3
AGC Threshold	FM(6.25k)	481	-64.8
AGC Threshold	FM(6.25k)	508.996875	-64.6
AGC Threshold	FM(12.5k)	450.00625	-64.3
AGC Threshold	FM(12.5k)	481	-64.8
AGC Threshold	FM(12.5k)	508.99375	-64.6
AGC Threshold	FM(25k)	450.0125	-64.3
AGC Threshold	FM(25k)	481	-64.8
AGC Threshold	FM(25k)	508.9875	-64.6

Uplink: 455MHz ~ 512MHz

Test items	Modulation	Carrier frequency(MHz)	Level(dBm)
AGC Threshold	C4FM	455.00625	-72.7
AGC Threshold	C4FM	484	-73.0
AGC Threshold	C4FM	511.99735	-72.9
AGC Threshold	FM(6.25k)	455.003125	-72.8
AGC Threshold	FM(6.25k)	484	-72.8
AGC Threshold	FM(6.25k)	511.996875	-72.9
AGC Threshold	FM(12.5k)	455.00625	-72.7
AGC Threshold	FM(12.5k)	484	-73.0
AGC Threshold	FM(12.5k)	511.99375	-72.9
AGC Threshold	FM(25k)	455.0125	-72.7
AGC Threshold	FM(25k)	484	-73.0
AGC Threshold	FM(25k)	511.9875	-72.9

## 7.2.2 Conducted Output Power and Amplifier Gain

Test Requirement: FCC part 90.219(e)(1)

90.219(e) The output power capability of a signal booster must be designed for deployments providing a radiated power not exceeding 5 Watts ERP for each retransmitted channel.

Test Method: FCC part 2.1037

EUT Operation:

Status: Drive the EUT to maximum output power.

Conditions: Normal conditions

Application: Cellular Band RF output ports

Test Configuration:

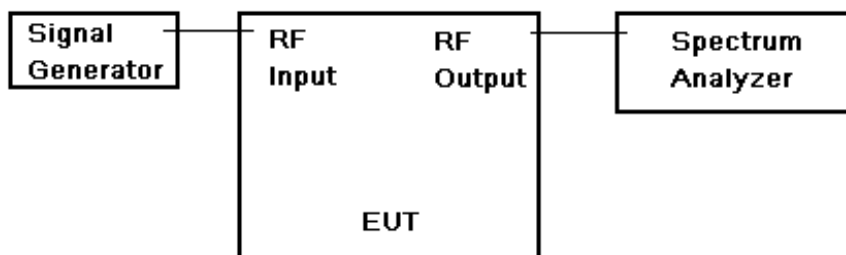

Fig.1 RF Output Power test configuration



Test Procedure:

RF output power test procedure:

1.
  - a) Connect the equipment as illustrated, when the output power is over the max value of the Spectrum Analyzer, add the attenuator to avoid destroying the facility.
  - b) Set the center frequency of the spectrum analyzer to the assigned transmitter frequency, key the transmitter, and set the level of the carrier to the full scale reference line.
  - c) do not apply any tone to modulate the EUT.
  - d1) Adjust the spectrum analyzer for the following settings:
    - 1) Resolution Bandwidth >> the carrier bandwidth,
    - 2) Video Bandwidth refer to standard requirement.
  - d2) Use spectrum analyzer channel power measurement function;
  - e) Record the frequencies and levels of carrier power;
  - f) Calculate the signal link way loss and final power value.
- Or 2.
  - a) Connect the equipment as illustrated;
  - b) Read the value from the power meter;
  - c) Calculate the signal link way loss and final power value.

RF gain test procedure:

The EUT was connected to a spectrum analyzer through a 40dB power attenuator. All cable and attenuator losses were input into the spectrum analyzer

As a reference level offset to ensure accurate readings were obtained.

A CW signal was utilized, set to the frequency of the peak amplitude measured in the Out of Band Rejection test.

The RF input signal level was set to 0.2dB below the AGC Threshold.

$\text{Gain(dB)} = \text{Output Power(dBm)} - \text{Input Power(dBm)}$

Remark:

Output power –

Power on Form 731 should be clearly understood as either composite of multichannels or per carrier. If power is composite include in comments field: "Power output listed is composite for multi-channel operation."

Check that the input drive level is at maximum input rating and maximum gain

settings for all tests. Check both uplink and downlink input levels. See manual or

brochures/technical description for maximum rating. May need to check FCC identifier of transmitter used for tests.

Confirm device can not operate in saturation. Are there means to control maximum power and to assure linear operation (use in system configuration may be necessary)? How is saturation or over-modulation prevented for pulsed signal inputs?

**7.2.2.1 Measurement Record:**

**Downlink: 450MHz ~ 509MHz**

Modulation	Carrier frequency(MHz)	Input Power (dBm)	Output Power (dBm)	Gain(dB)	Maximum Output power(dBm)	Limit((dBm)	Result
C4FM	450.00625	-67	33.62	100.62	35.9	37	Pass
C4FM	481	-67	33.94	100.94	35.4	37	Pass
C4FM	508.99735	-67	32.57	99.57	35.7	37	Pass
FM(6.25k)	450.003125	-67	33.62	100.62	35.9	37	Pass
FM(6.25k)	481	-67	33.94	100.94	35.4	37	Pass
FM(6.25k)	508.996875	-67	32.57	99.57	35.6	37	Pass
FM(12.5k)	450.00625	-67	33.62	100.62	35.9	37	Pass
FM(12.5k)	481	-67	33.94	100.94	35.4	37	Pass
FM(12.5k)	508.99375	-67	32.57	99.57	35.6	37	Pass
FM(25k)	450.0125	-67	33.62	100.62	35.9	37	Pass
FM(25k)	481	-67	33.94	100.94	35.4	37	Pass
FM(25k)	508.9875	-67	32.57	99.57	35.6	37	Pass

**Uplink: 455MHz ~ 512MHz**

Modulation	Carrier frequency(MHz)	Input Power (dBm)	Output Power (dBm)	Gain(dB)	Maximum Output power(dBm)	Limit((dBm)	Result
C4FM	455.00625	-76	23.59	99.59	27.5	37	Pass
C4FM	484	-76	23.41	99.41	27.2	37	Pass
C4FM	511.99735	-76	22.54	98.54	27.3	37	Pass
FM(6.25k)	455.003125	-76	23.59	99.59	27.4	37	Pass
FM(6.25k)	484	-76	23.41	99.41	27.4	37	Pass
FM(6.25k)	511.996875	-76	22.54	98.54	27.3	37	Pass
FM(12.5k)	455.00625	-76	23.59	99.59	27.5	37	Pass
FM(12.5k)	484	-76	23.41	99.41	27.2	37	Pass
FM(12.5k)	511.99375	-76	22.54	98.54	27.3	37	Pass
FM(25k)	455.0125	-76	23.59	99.59	27.5	37	Pass
FM(25k)	484	-76	23.41	99.41	27.2	37	Pass
FM(25k)	511.9875	-76	22.54	98.54	27.3	37	Pass

### 7.2.3 Conducted Spurious Emissions

Test Requirement: FCC part 90.219€ (3)

(3) Spurious emissions from a signal booster must not exceed -13dBm within any 100 kHz measurement bandwidth..

Test Method: FCC part 2.1053

EUT Operation:

Status: Drive the EUT to maximum output power.

Conditions: Normal conditions

Application: Cellular Band RF output ports

Test Configuration:

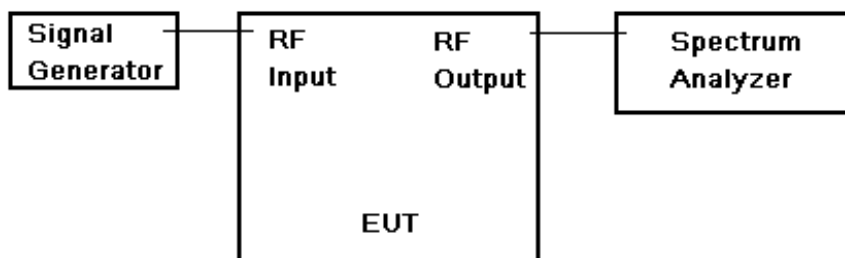
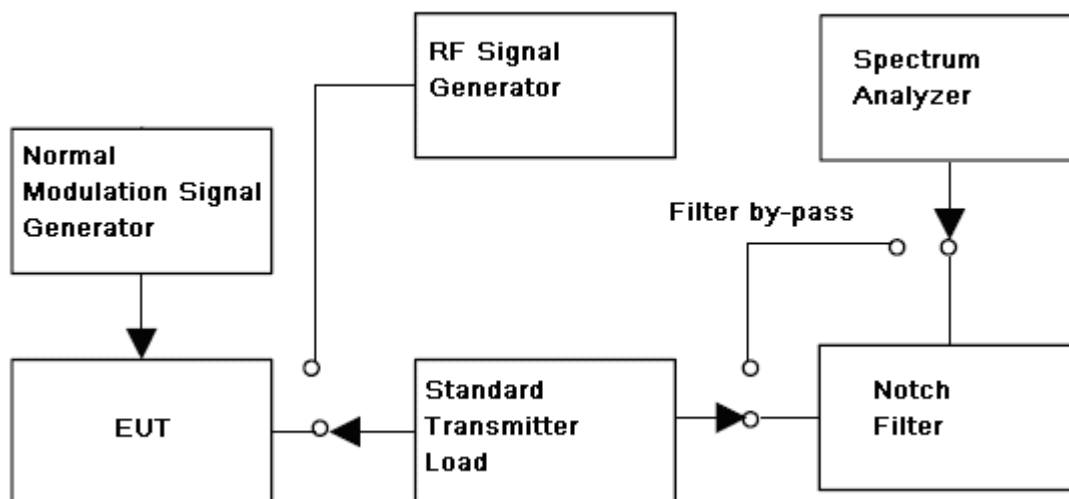

Fig.2. Conducted Spurious Emissions test configuration



Test Procedure:

Conducted Emissions test procedure:

- Connect the equipment as illustrated, with the notch filter by-passed, when the output power is over the max value of the Spectrum Analyzer, add the attenuator to avoid destroying the facility.
- Set the center frequency of the spectrum analyzer to the assigned transmitter frequency, key the transmitter, and set the level of the carrier to the full scale reference line.
- do not apply any tone to modulate the EUT.



d) Adjust the spectrum analyzer for the following settings:

1) Resolution Bandwidth,( base the standard, apply the different set),her is 100KHz for frequency band less than 1GHz, 1MHz for frequency over 1GHz;

2) Video Bandwidth refer to standard requirement.

e) Adjust the center frequency of the spectrum analyzer for incremental coverage of the range from:

1) the lowest radio frequency generated in the equipment, it can be 9KHz base the test method, here select 30MHz as lowest frequency start point;

2) the highest radion frequency shall higher than 10 times of carrier frequency;

f ) Record the frequencies and levels of spurious emissions from step e)

Remark:

The notch filter is used for avoid the EUT fundamental carrier output power making the spectrum overload and the harmonic spurious brought by it.

When the EUT fundamental carrier is not enough to make the status, the notch filter could be not used.

### 7.2.3.1 Measurement Record:

#### 3. Downlink: 450MHz ~ 509MHz

##### Remark:

The data of the C4FM mode and FM(6.25k)、FM(12.5k) is almost the same with FM(25k)mode, so we only show the photo in the FM(25k) mode, others record the data.

#### 1.1 For FM(25k)mode:

##### 1) Lowest frequency

9KHz to 1GHz

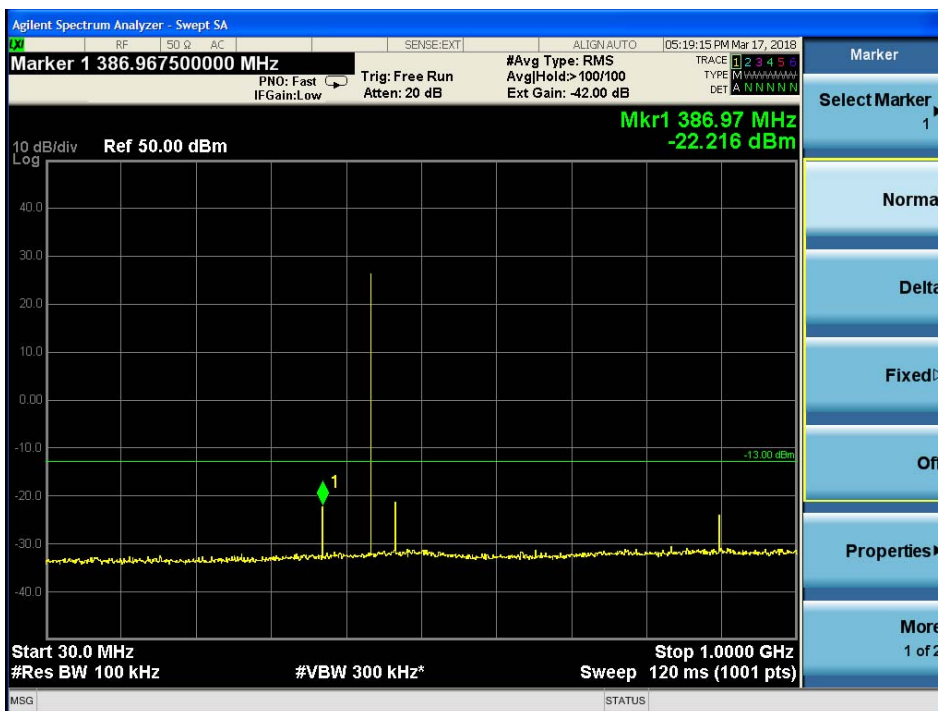

1GHz to 3.6GHz

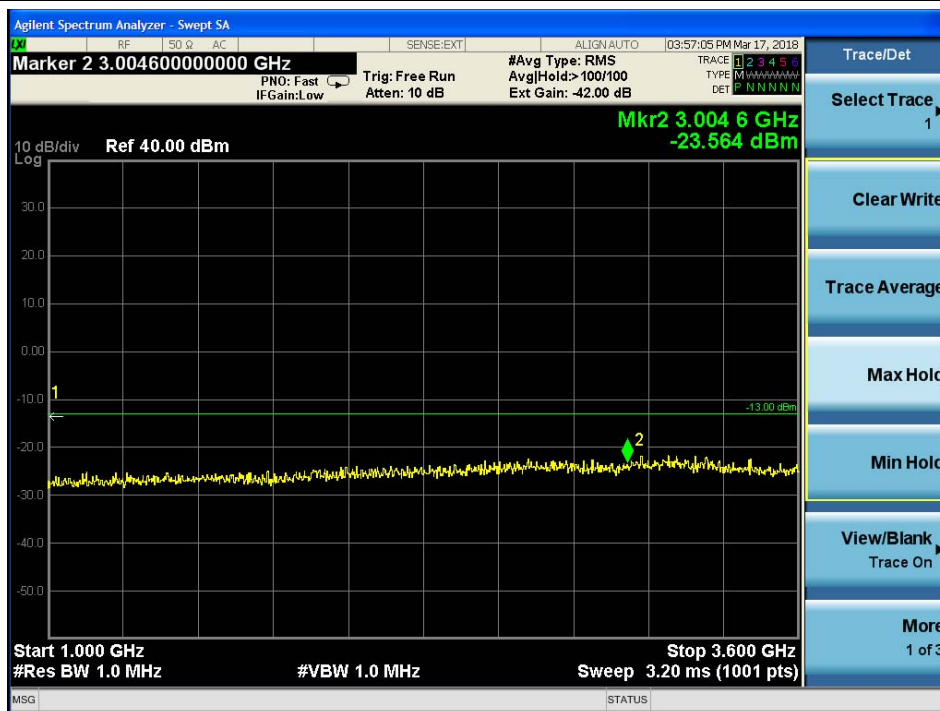

2) Middle frequency  
9KHz to 1GHz

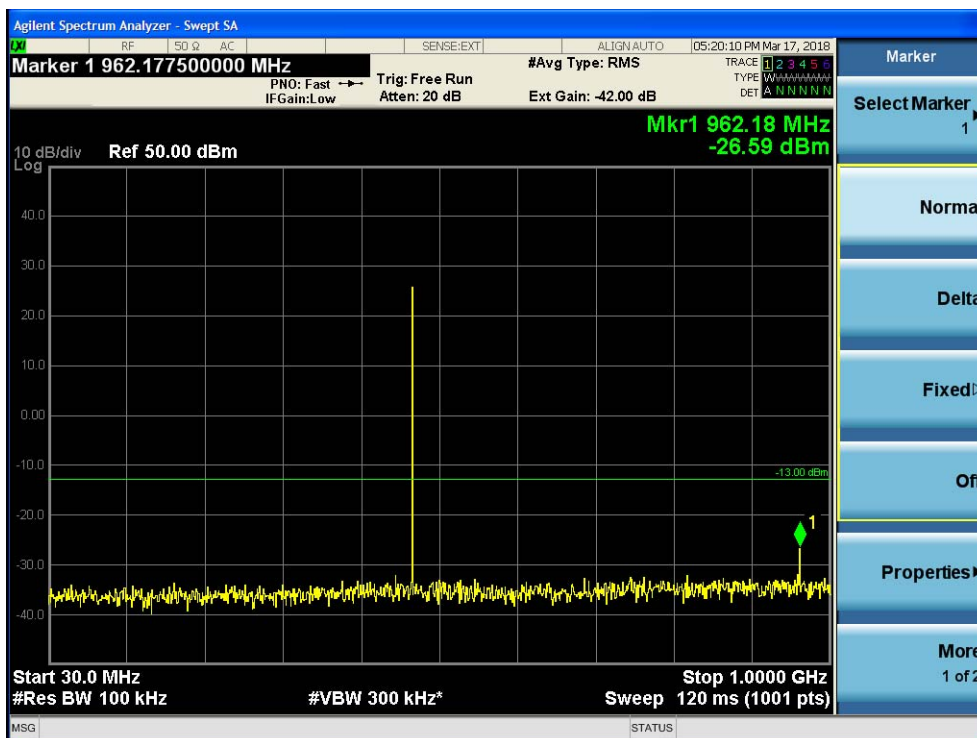

1GHz to 3.6GHz

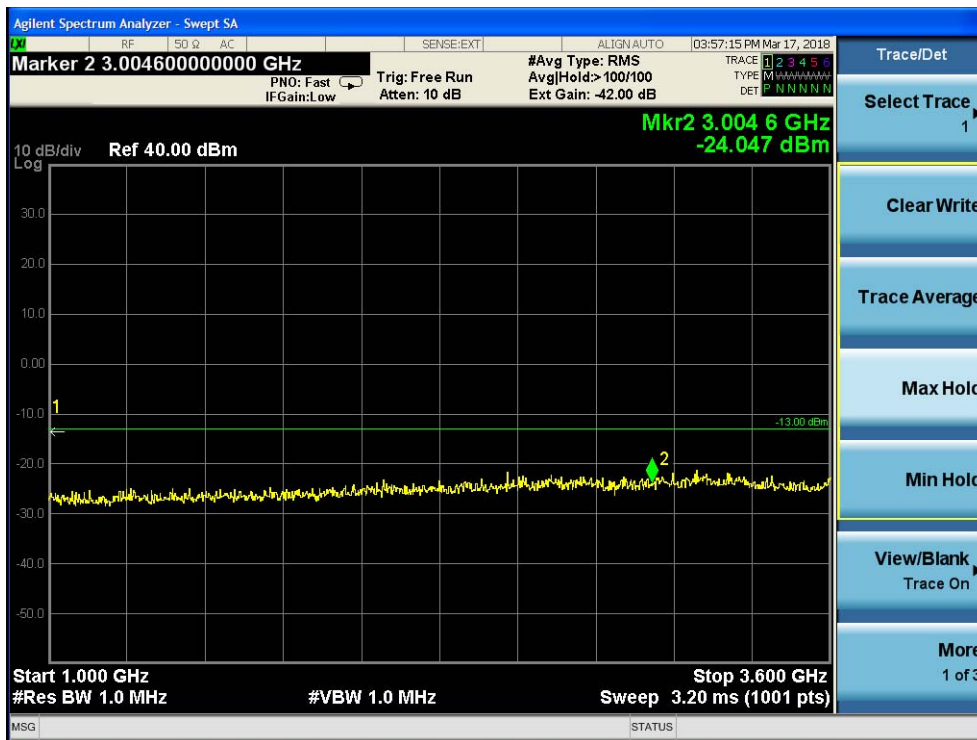

3)highest frequency

9KHz to 1GHz

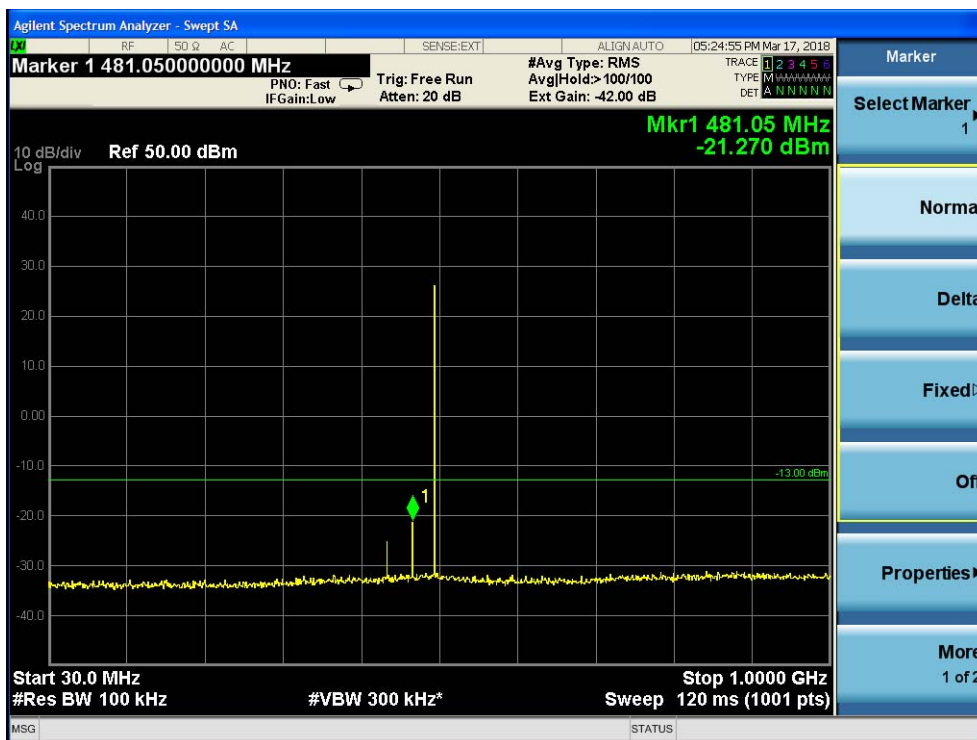

1GHz to 3.6GHz



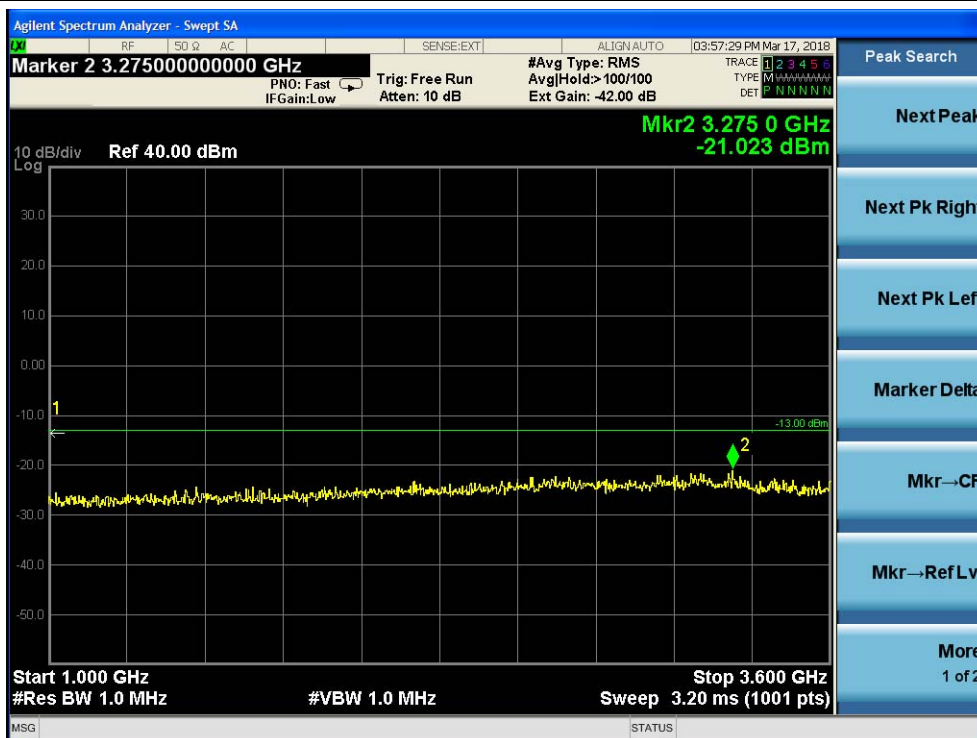





For C4FM mode:

1) lowest frequency:

Measurement Record:				
Frequency range	Measurement bandwidth	Spurious Emission Level(dBm)	Limit(dBm)	Over Limit(dB)
9KHz to 1GHz	RBW=100KHz	-26.53	-13.0	-13.53
1GHz to 10GHz	RBW=1MHz	-19.72	-13.0	-6.72
3GHz to 10GHz	RBW=1MHz	-22.67	-13.0	-9.67

2) Middle frequency:

Measurement Record:				
Frequency range	Measurement bandwidth	Spurious Emission Level(dBm)	Limit(dBm)	Over Limit(dB)
9KHz to 1GHz	RBW=100KHz	-24.72	-13.0	-11.72
1GHz to 3.6GHz	RBW=1MHz	-20.89	-13.0	-7.89
3GHz to 10GHz	RBW=1MHz	-23.43	-13.0	-10.43

3) highest frequency

Measurement Record:				
Frequency range	Measurement bandwidth	Spurious Emission Level(dBm)	Limit(dBm)	Over Limit(dB)
9KHz to 1GHz	RBW=100KHz	-23.85	-13.0	-10.85
1GHz to 3.6GHz	RBW=1MHz	-20.47	-13.0	-7.47
3GHz to 10GHz	RBW=1MHz	-22.81	-13.0	-9.81



For FM(6.25k) mode:

1) lowest frequency:

Measurement Record:				
Frequency range	Measurement bandwidth	Spurious Emission Level(dBm)	Limit(dBm)	Over Limit(dB)
9KHz to 1GHz	RBW=100KHz	-24.82	-13.0	-11.82
1GHz to 10GHz	RBW=1MHz	-19.56	-13.0	-6.56
3GHz to 10GHz	RBW=1MHz	-23.97	-13.0	-10.97

2) Middle frequency:

Measurement Record:				
Frequency range	Measurement bandwidth	Spurious Emission Level(dBm)	Limit(dBm)	Over Limit(dB)
9KHz to 1GHz	RBW=100KHz	-25.37	-13.0	-12.37
1GHz to 3.6GHz	RBW=1MHz	-20.91	-13.0	-7.91
3GHz to 10GHz	RBW=1MHz	-22.86	-13.0	-9.86

3) highest frequency

Measurement Record:				
Frequency range	Measurement bandwidth	Spurious Emission Level(dBm)	Limit(dBm)	Over Limit(dB)
9KHz to 1GHz	RBW=100KHz	-26.82	-13.0	-13.82
1GHz to 3.6GHz	RBW=1MHz	-21.45	-13.0	-8.45
3GHz to 10GHz	RBW=1MHz	-23.57	-13.0	-10.57



For FM(12.5k) mode:

1) lowest frequency:

Measurement Record:				
Frequency range	Measurement bandwidth	Spurious Emission Level(dBm)	Limit(dBm)	Over Limit(dB)
9KHz to 1GHz	RBW=100KHz	-25.26	-13.0	-12.26
1GHz to 10GHz	RBW=1MHz	-21.47	-13.0	-8.47
3.6GHz to 10GHz	RBW=1MHz	-23.92	-13.0	-10.92

2) Middle frequency:

Measurement Record:				
Frequency range	Measurement bandwidth	Spurious Emission Level(dBm)	Limit(dBm)	Over Limit(dB)
9KHz to 1GHz	RBW=100KHz	-25.73	-13.0	-12.73
1GHz to 3.6GHz	RBW=1MHz	-20.89	-13.0	-7.89
3.6GHz to 10GHz	RBW=1MHz	-21.65	-13.0	-8.65

3) highest frequency

Measurement Record:				
Frequency range	Measurement bandwidth	Spurious Emission Level(dBm)	Limit(dBm)	Over Limit(dB)
9KHz to 1GHz	RBW=100KHz	-23.82	-13.0	-10.82
1GHz to 3.6GHz	RBW=1MHz	-22.36	-13.0	-9.36
3.6GHz to 10GHz	RBW=1MHz	-21.24	-13.0	-8.24

**4.Uplink: 455MHz ~ 512MHz**

**1.1 For FM(25k) mode:**

**1 )lowest frequency**

9KHz to 1GHz

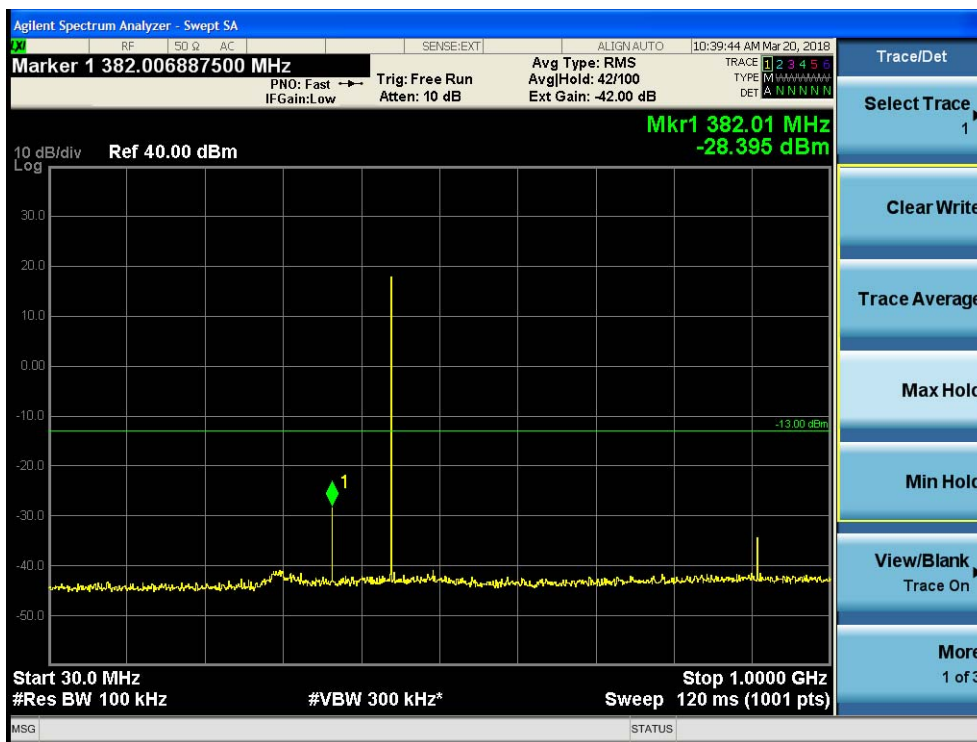

1GHz to 3.6GHz

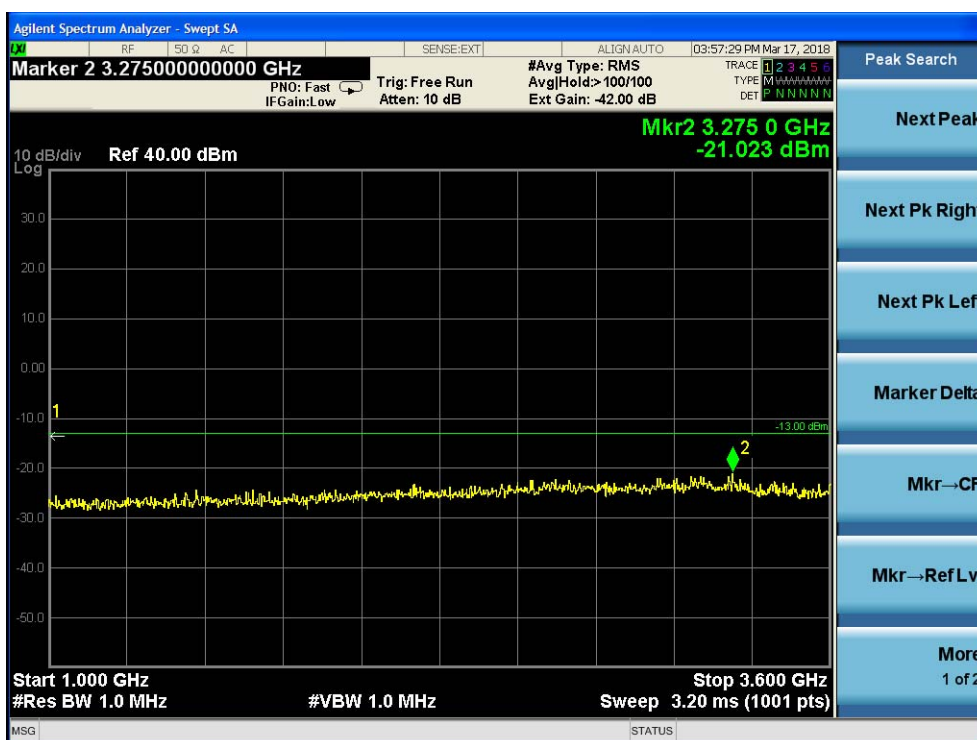



2) Middle frequency  
9KHz to 1GHz

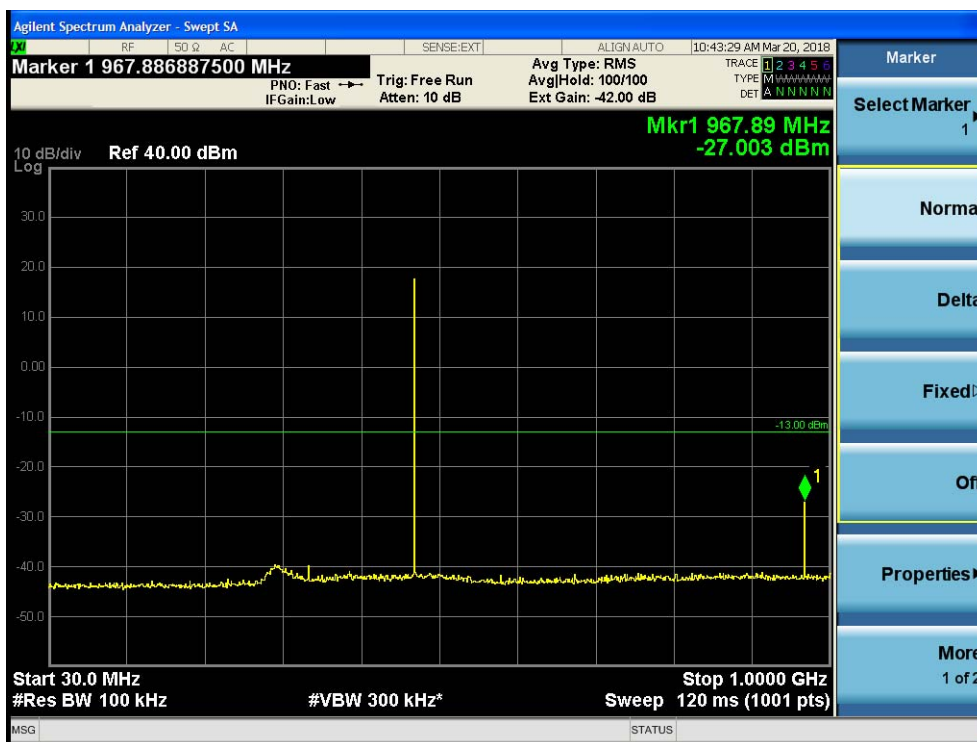

1GHz to 3.6GHz

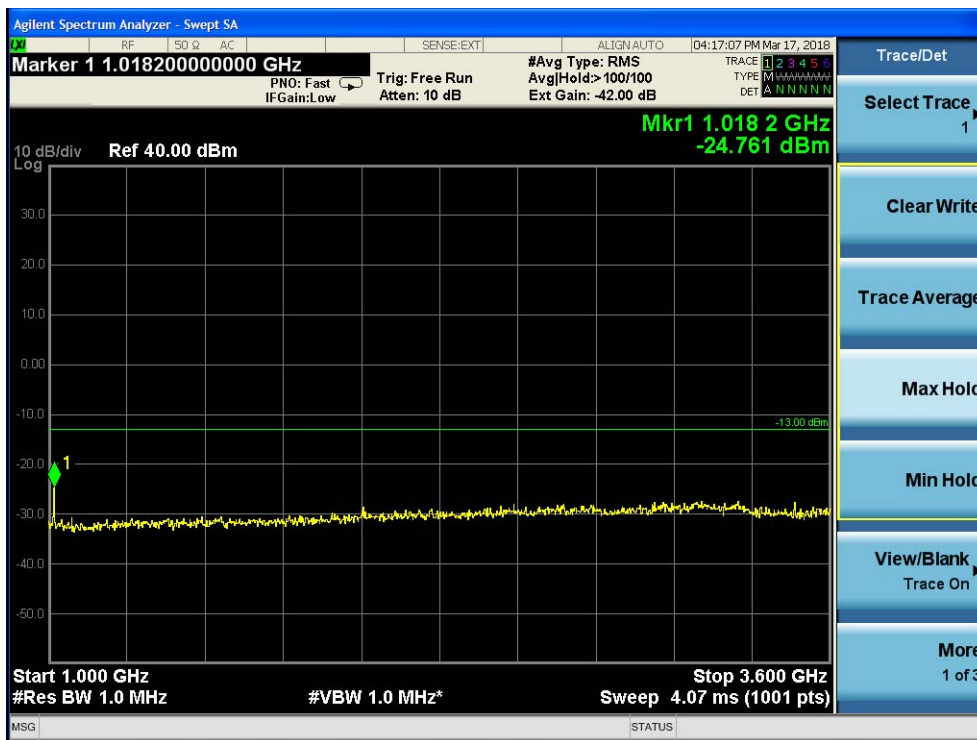

**3)highest frequency**  
9KHz to 1GHz

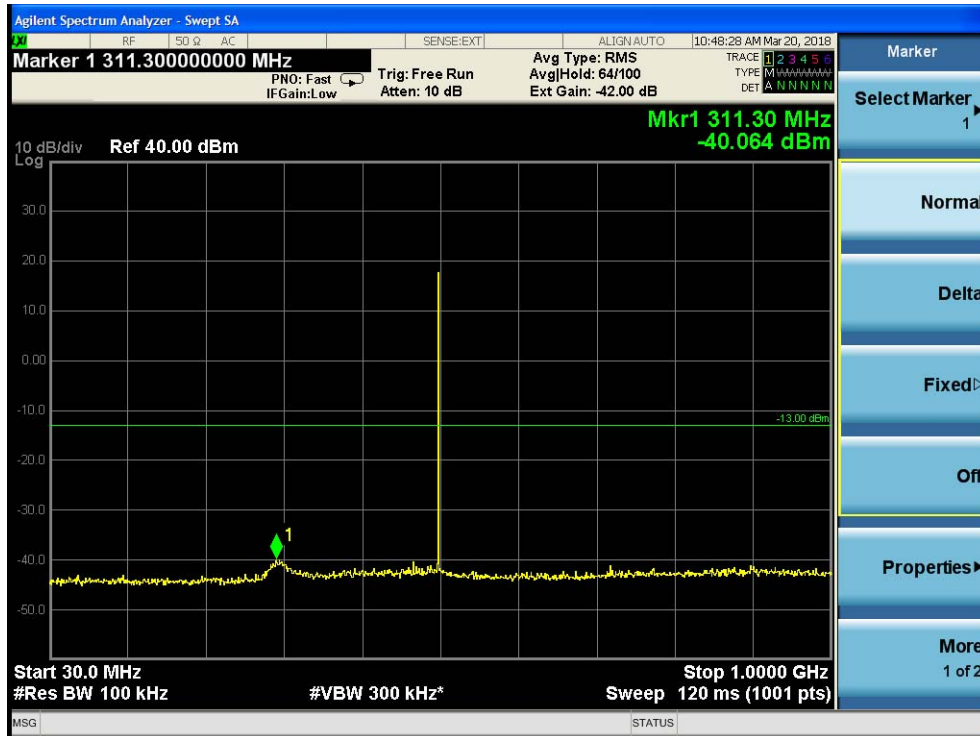

1GHz to 3.6GHz

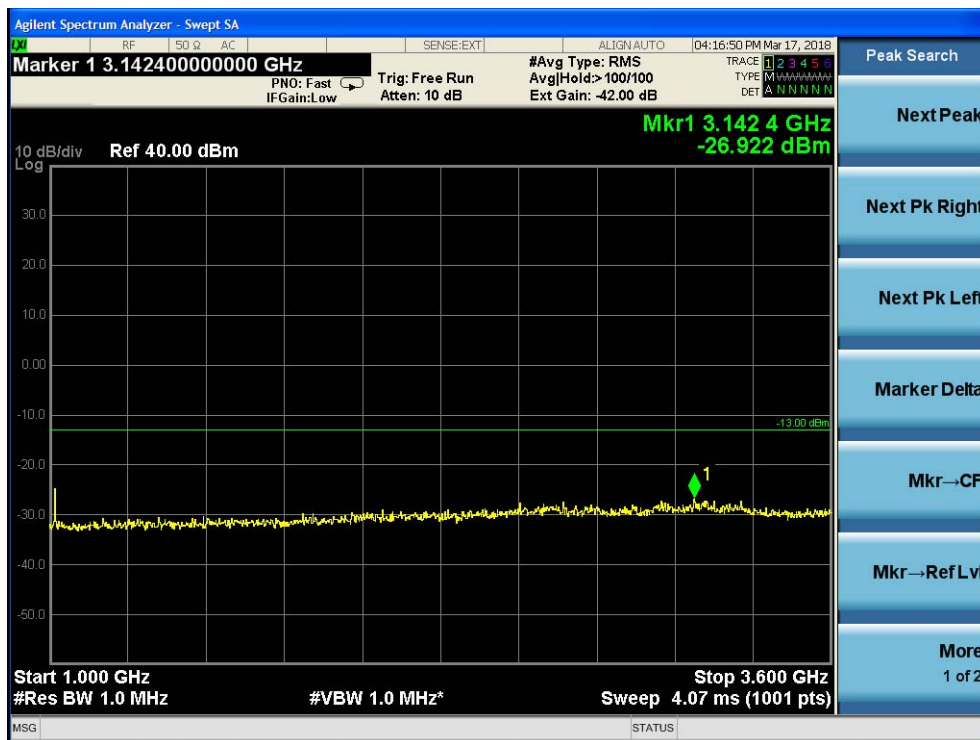



For C4FM mode:

1) lowest frequency:

Measurement Record:				
Frequency range	Measurement bandwidth	Spurious Emission Level(dBm)	Limit(dBm)	Over Limit(dB)
9KHz to 1GHz	RBW=100KHz	-25.23	-13.0	-12.23
1GHz to 10GHz	RBW=1MHz	-21.16	-13.0	-8.16
3.6GHz to 10GHz z	RBW=1MHz	-22.79	-13.0	-9.79

2) Middle frequency:

Measurement Record:				
Frequency range	Measurement bandwidth	Spurious Emission Level(dBm)	Limit(dBm)	Over Limit(dB)
9KHz to 1GHz	RBW=100KHz	-24.63	-13.0	-11.63
1GHz to 3.6GHz	RBW=1MHz	-20.95	-13.0	-7.95
3.6GHz to 10GHz	RBW=1MHz	-21.83	-13.0	-8.83

3) highest frequency

Measurement Record:				
Frequency range	Measurement bandwidth	Spurious Emission Level(dBm)	Limit(dBm)	Over Limit(dB)
9KHz to 1GHz	RBW=100KHz	-25.48	-13.0	-12.48
1GHz to 3.6GHz	RBW=1MHz	-23.92	-13.0	-10.92
3.6GHz to 10GHz	RBW=1MHz	-20.29	-13.0	-7.29





For FM(6.25k) mode:

1) lowest frequency:

Measurement Record:				
Frequency range	Measurement bandwidth	Spurious Emission Level(dBm)	Limit(dBm)	Over Limit(dB)
9KHz to 1GHz	RBW=100KHz	-22.84	-13.0	-9.84
1GHz to 10GHz	RBW=1MHz	-20.92	-13.0	-7.92
3.6GHz to 10GHz	RBW=1MHz	-23.61	-13.0	-10.61

2) Middle frequency:

Measurement Record:				
Frequency range	Measurement bandwidth	Spurious Emission Level(dBm)	Limit(dBm)	Over Limit(dB)
9KHz to 1GHz	RBW=100KHz	-23.82	-13.0	-10.82
1GHz to 3.6GHz	RBW=1MHz	-21.67	-13.0	-8.67
3.6GHz to 10GHz	RBW=1MHz	-22.89	-13.0	-9.89

3) highest frequency:

Measurement Record:				
Frequency range	Measurement bandwidth	Spurious Emission Level(dBm)	Limit(dBm)	Over Limit(dB)
9KHz to 1GHz	RBW=100KHz	-27.32	-13.0	-14.32
1GHz to 3.6GHz	RBW=1MHz	-20.17	-13.0	-7.17
3.6GHz to 10GHz	RBW=1MHz	-22.45	-13.0	-9.45





For FM(12.5k) mode:

1) lowest frequency:

Measurement Record:				
Frequency range	Measurement bandwidth	Spurious Emission Level(dBm)	Limit(dBm)	Over Limit(dB)
9KHz to 1GHz	RBW=100KHz	-24.67	-13.0	-11.67
1GHz to 10GHz	RBW=1MHz	-21.35	-13.0	-8.35
3.6GHz to 10GHz	RBW=1MHz	-23.83	-13.0	-10.83

2) Middle frequency:

Measurement Record:				
Frequency range	Measurement bandwidth	Spurious Emission Level(dBm)	Limit(dBm)	Over Limit(dB)
9KHz to 1GHz	RBW=100KHz	-23.71	-13.0	-10.71
1GHz to 3.6GHz	RBW=1MHz	-20.92	-13.0	-7.92
3.6GHz to 10GHz	RBW=1MHz	-22.67	-13.0	-9.67

3) highest frequency:

Measurement Record:				
Frequency range	Measurement bandwidth	Spurious Emission Level(dBm)	Limit(dBm)	Over Limit(dB)
9KHz to 1GHz	RBW=100KHz	-22.38	-13.0	-9.38
1GHz to 3.6GHz	RBW=1MHz	-21.57	-13.0	-8.57
3.6GHz to 10GHz	RBW=1MHz	-23.85	-13.0	-10.85

## 7.2.4 Emission Mask

Test Requirement: FCC part 90.210  
90.210, table "Application Emission Mask"

### APPLICABLE EMISSION MASKS

Frequency band (MHz)	Mask for equipment with audio low pass filter	Mask for equipment without audio low pass filter
Below 25 <sup>1</sup>	A or B	A or C
25-50	B	C
72-76	B	C
150-174 <sup>2</sup>	B, D, or E	C, D or E
150 paging only	B	C
220-222	F	F
421-512 <sup>25</sup>	B, D, or E	C, D, or E
450 paging only	B	G
806-809,851-854 <sup>5</sup>	B	H
809-824,854-869 <sup>35</sup>	B	G
896-901,935-940	I	J
902-928	K	K
929-930	B	G
4940-4990 MHz	L or M	L or M
5850-5925 <sup>*</sup>		
All other bands	B	C

(b) *Emission Mask B*. For transmitters that are equipped with an audio low-pass filter, the power of any emission must be attenuated below the unmodulated carrier power (P) as follows:

(1) On any frequency removed from the assigned frequency by more than 50 percent, but not more than 100 percent of the authorized bandwidth: At least 25 dB.

(2) On any frequency removed from the assigned frequency by more than 100 percent, but not more than 250 percent of the authorized bandwidth: At least 35 dB.

(3) On any frequency removed from the assigned frequency by more than 250 percent of the authorized bandwidth: At least  $43 + 10 \log(P)$  dB.

(c) *Emission Mask C*. For transmitters that are not equipped with an audio low-pass filter, the power of any emission must be attenuated below the unmodulated carrier output power (P) as follows:

(1) On any frequency removed from the center of the authorized bandwidth by a displacement frequency ( $f_d$  in kHz) of more than 5 kHz, but not more than 10 kHz: At least  $83 \log(f_d/5)$  dB;

(2) On any frequency removed from the center of the authorized bandwidth by a displacement frequency ( $f_d$  in kHz) of more than 10 kHz, but not more than 250 percent of the authorized bandwidth: At least  $29 \log(f_d^2/11)$  dB or 50 dB, whichever is the lesser attenuation;

(3) On any frequency removed from the center of the authorized bandwidth by more than 250 percent of the authorized bandwidth: At least  $43 + 10 \log(P)$  dB.

(d) *Emission Mask D—12.5 kHz channel bandwidth equipment*. For transmitters designed to operate with a 12.5 kHz channel bandwidth, any emission must be attenuated below the power (P) of the highest emission contained within the authorized bandwidth as follows:

(1) On any frequency from the center of the authorized bandwidth  $f_0$  to 5.625 kHz removed from  $f_0$ : Zero dB.

(2) On any frequency removed from the center of the authorized bandwidth by a displacement frequency ( $f_d$  in kHz) of more than 5.625 kHz but no more than 12.5 kHz: At least  $7.27(f_d - 2.88)$  dB.

(3) On any frequency removed from the center of the authorized bandwidth by a displacement frequency ( $f_d$  in kHz) of more than 12.5 kHz: At least  $50 + 10 \log(P)$  dB or 70 dB, whichever is the lesser attenuation.

(e) *Emission Mask E—6.25 kHz or less channel bandwidth equipment.* For transmitters designed to operate with a 6.25 kHz or less bandwidth, any emission must be attenuated below the power (P) of the highest emission contained within the authorized bandwidth as follows:

(1) On any frequency from the center of the authorized bandwidth  $f_0$  to 3.0 kHz removed from  $f_0$ : Zero dB.

(2) On any frequency removed from the center of the authorized bandwidth by a displacement frequency ( $f_d$  in kHz) of more than 3.0 kHz but no more than 4.6 kHz: At least  $30 + 16.67(f_d - 3 \text{ kHz})$  or  $55 + 10 \log(P)$  or 65 dB, whichever is the lesser attenuation.

(3) On any frequency removed from the center of the authorized bandwidth by more than 4.6 kHz: At least  $55 + 10 \log(P)$  or 65 dB, whichever is the lesser attenuation.

Test Method: FCC part 2.1051  
 EUT Operation:  
 Status: Drive the EUT to maximum output power.  
 Conditions: Normal conditions  
 Application: Cellular Band RF output ports  
 Test Configuration:

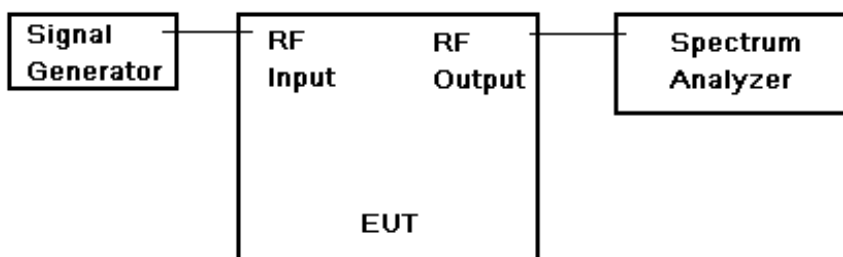
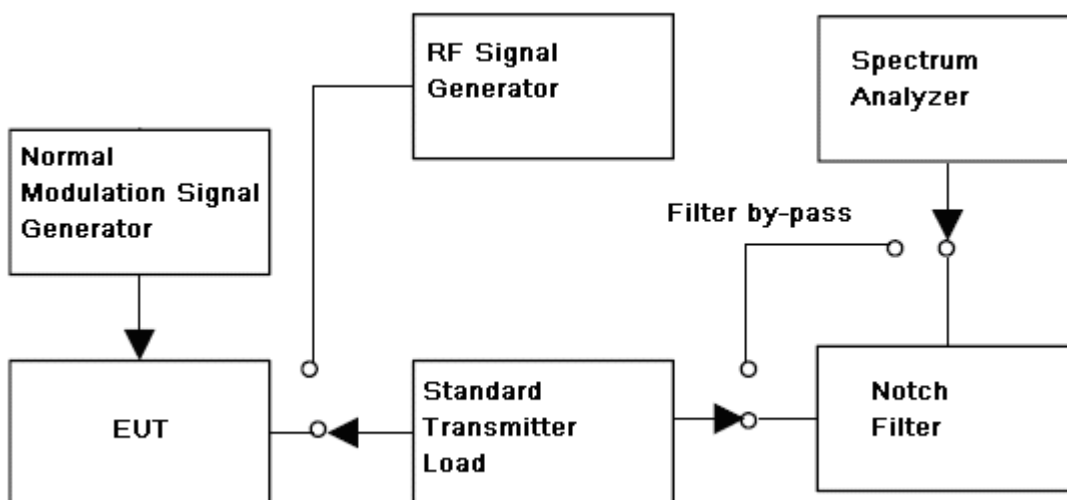

Fig.2. Conducted Spurious Emissions test configuration



Test Procedure: Conducted Emissions test procedure:  
 a) Connect the equipment as illustrated, with the notch filter by-passed, when the output power is over the max value of the Spectrum Analyzer, add the attenuator to avoid destroying the facility.  
 b) Set the center frequency of the spectrum analyzer to the assigned transmitter



frequency, key the transmitter, and set the level of the carrier to the full scale reference line.

c) do not apply any tone to modulate the EUT.

d) Adjust the spectrum analyzer for the following settings:

1) Resolution Bandwidth,( base the standard, apply the different set),her is 100KHz for frequency band less than 1GHz, 1MHz for frequency over 1GHz;

2) Video Bandwidth refer to standard requirement.

e) Adjust the center frequency of the spectrum analyzer for incremental coverage of the range from:

1) the lowest radio frequency generated in the equipment, it can be 9KHz base the test method, here select 30MHz as lowest frequency start point;

2) the highest radion frequency shall higher than 10 times of carrier frequency;

f) Record the frequencies and levels of spurious emissions from step e)

Remark:

The notch filter is used for avoid the EUT fundamental carrier output power making the spectrum overload and the harmonic spurious brought by it.

When the EUT fundamental carrier is not enough to make the status, the notch filter could be not used.

### 7.2.4.1 Measurement Record:

- 1. Downlink: 450MHz ~ 509MHz
- 1.1 For C4FM mode:
- 1) Lowest frequency

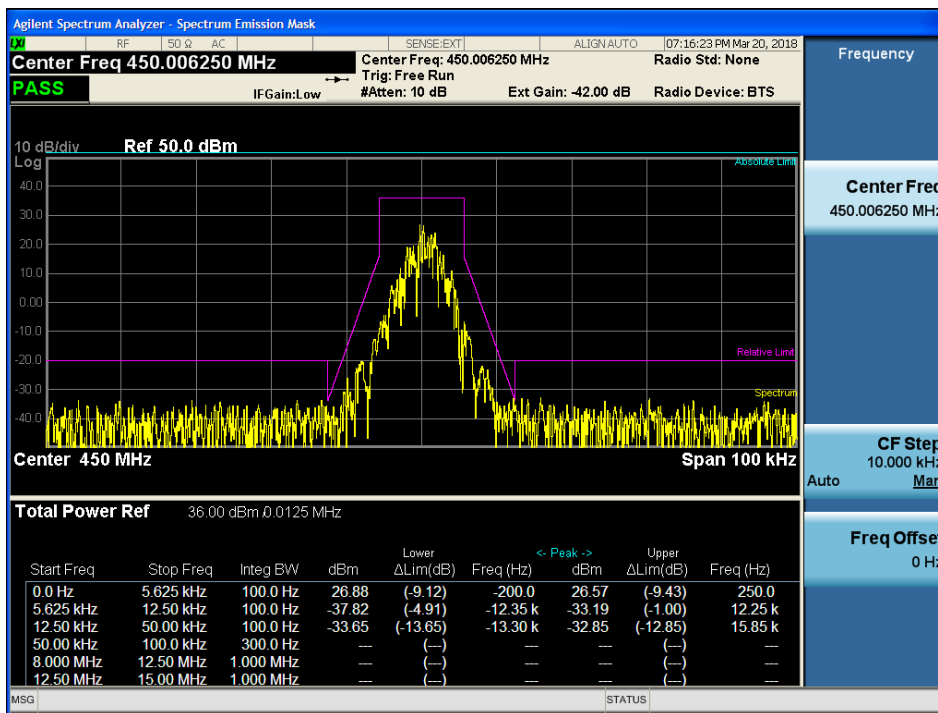

### 2) Middle frequency

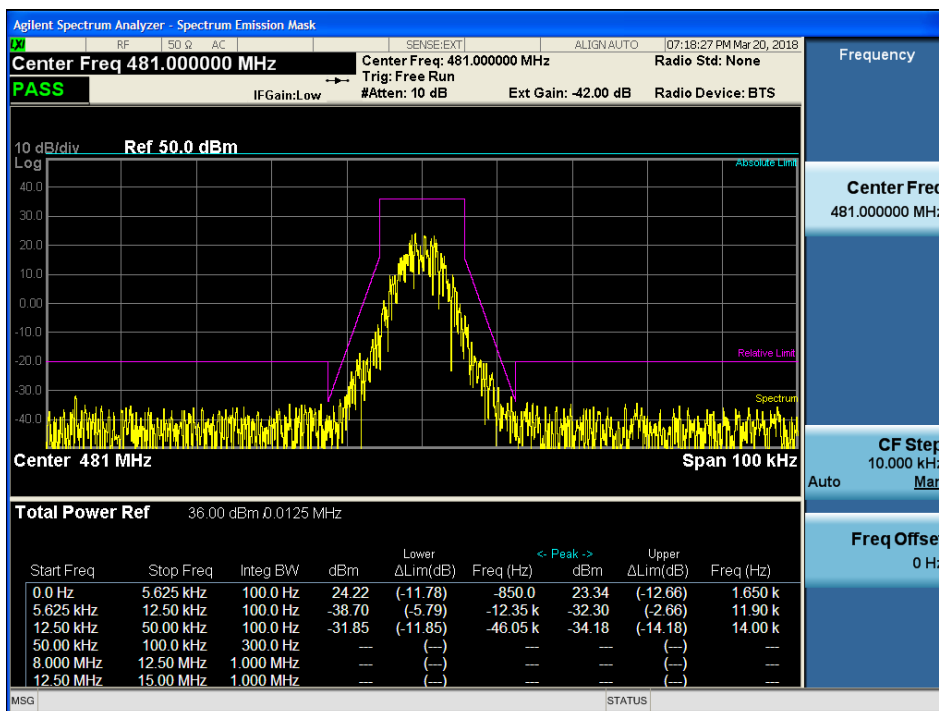



3) highest frequency

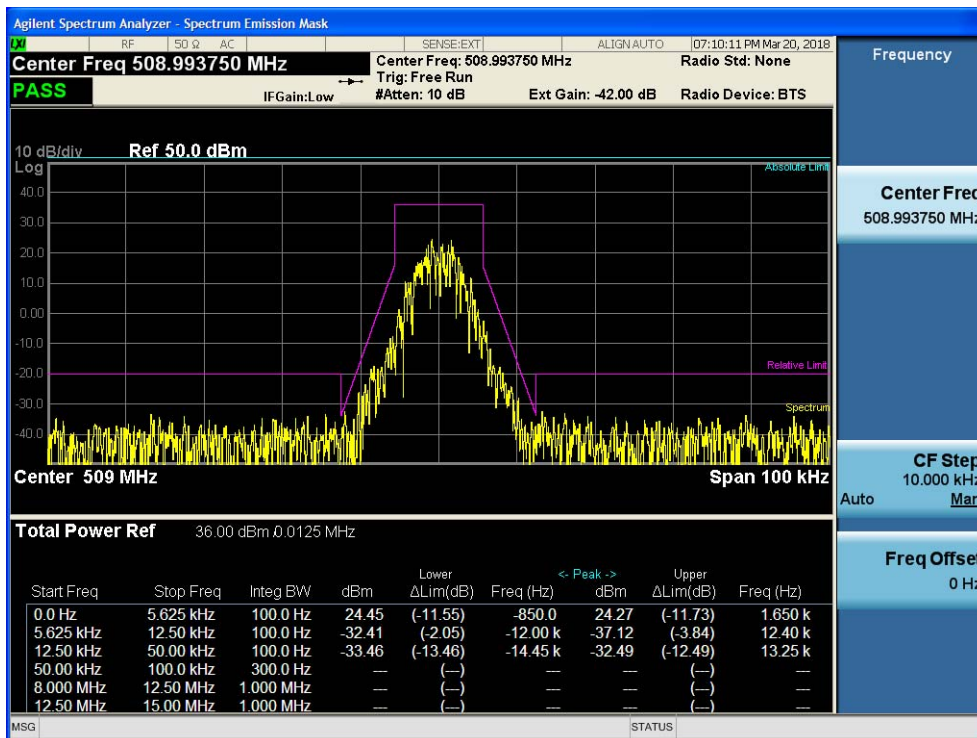

1.2 For FM(6.25k) mode:  
1) lowest frequency

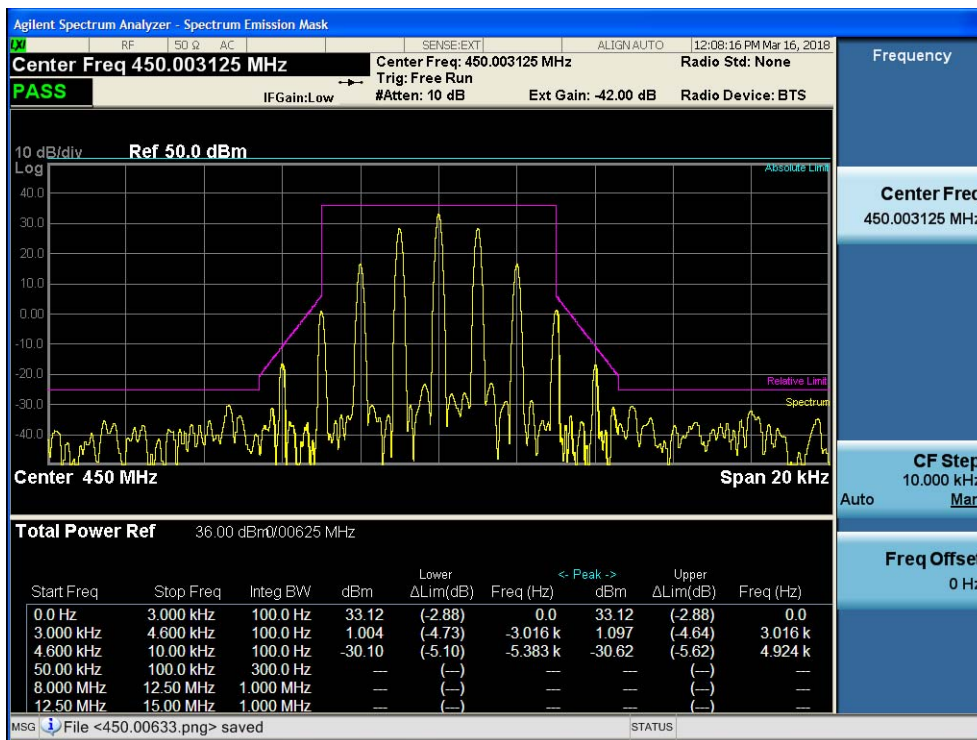

2) Middle frequency

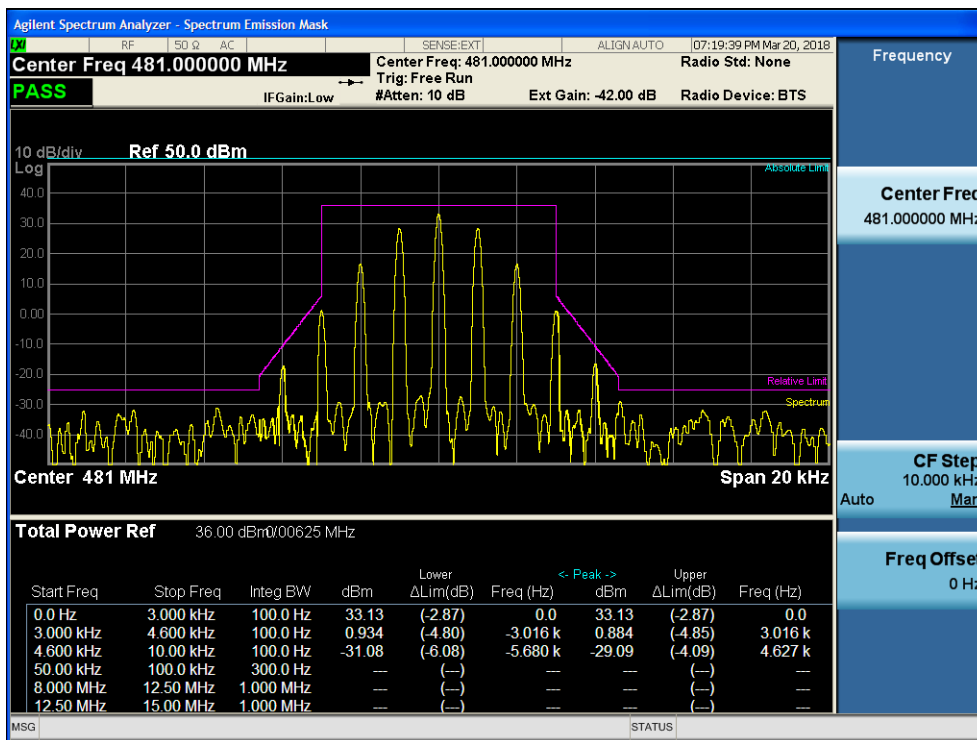





3) highest frequency

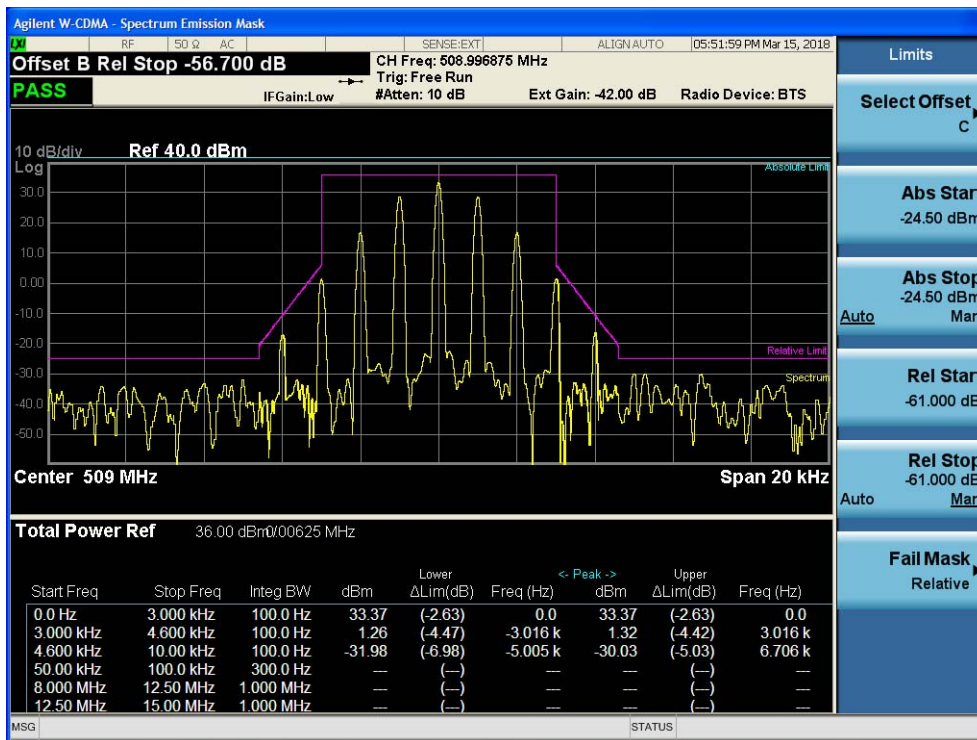



1.3 For FM(12.5k) mode:  
1) lowest frequency

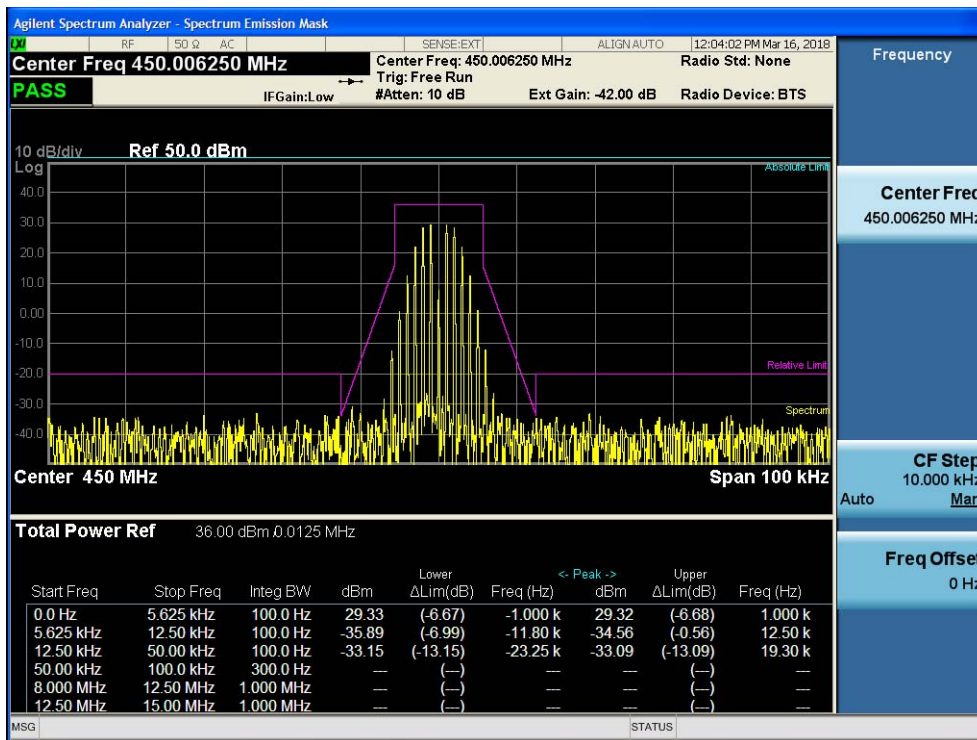

2) Middle frequency

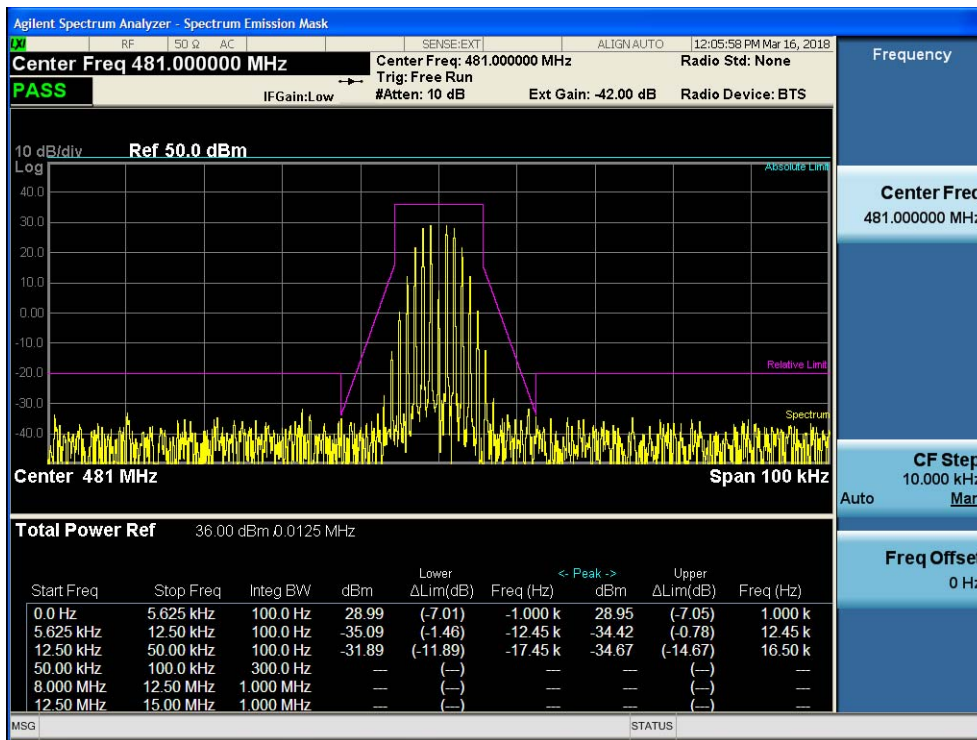



### 3) highest frequency

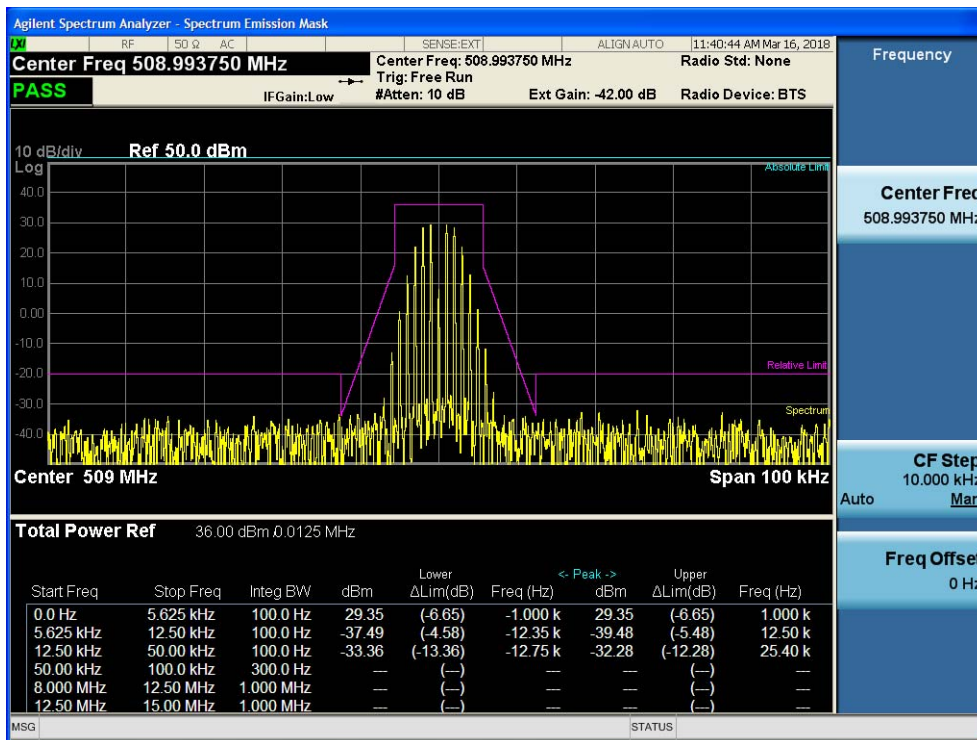

1.4 For FM(25k) mode(with audio low pass filter):

1) lowest frequency

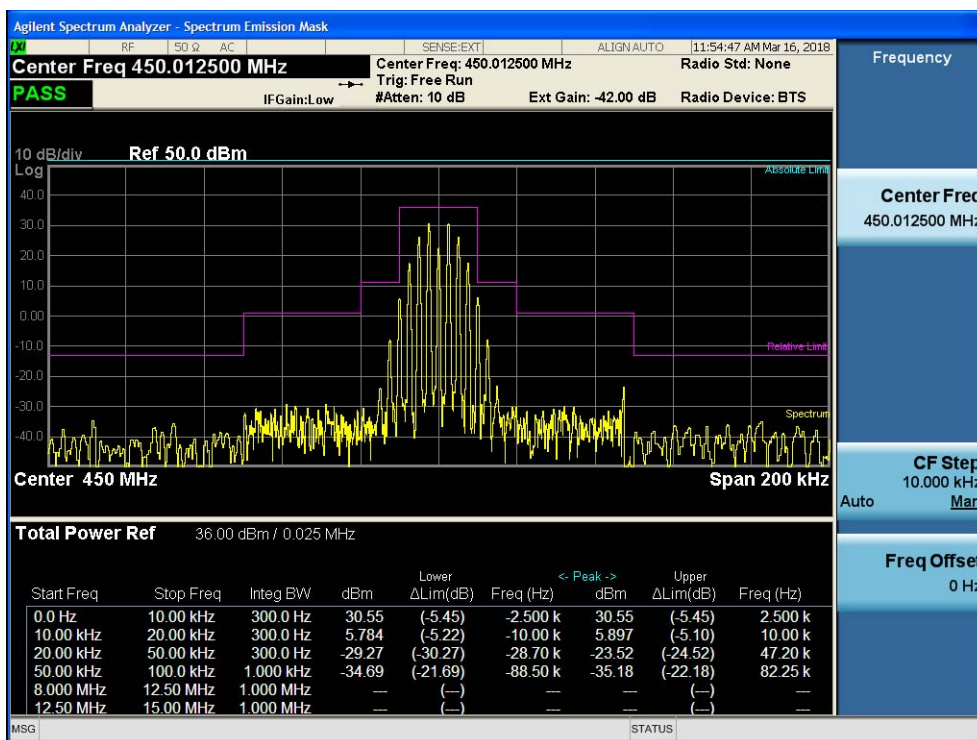

2) Middle frequency

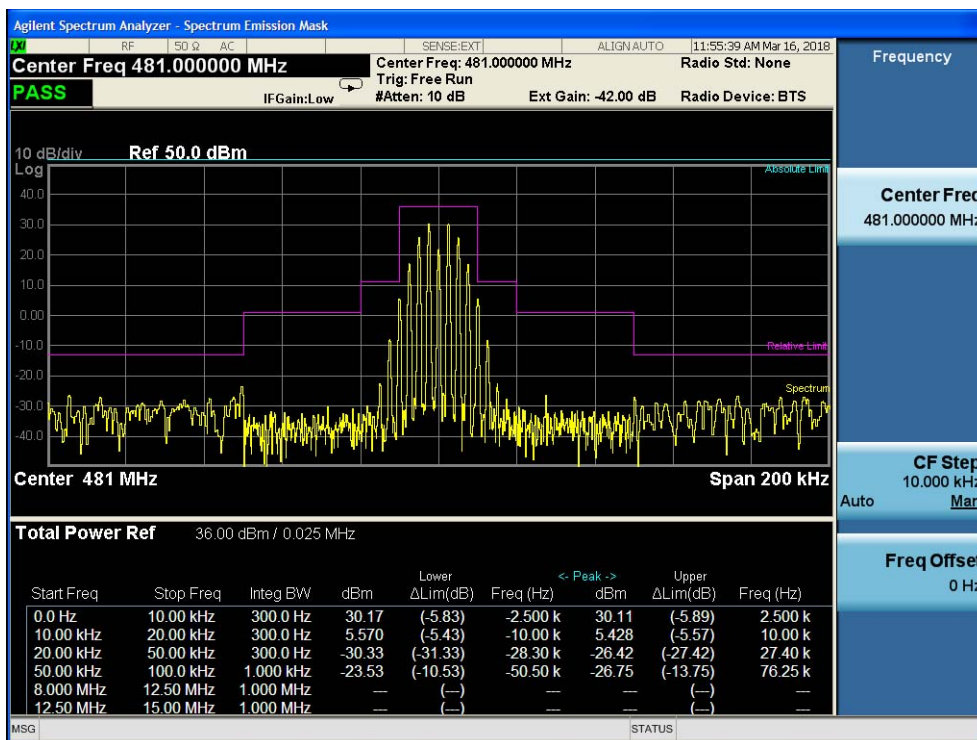

### 3) highest frequency

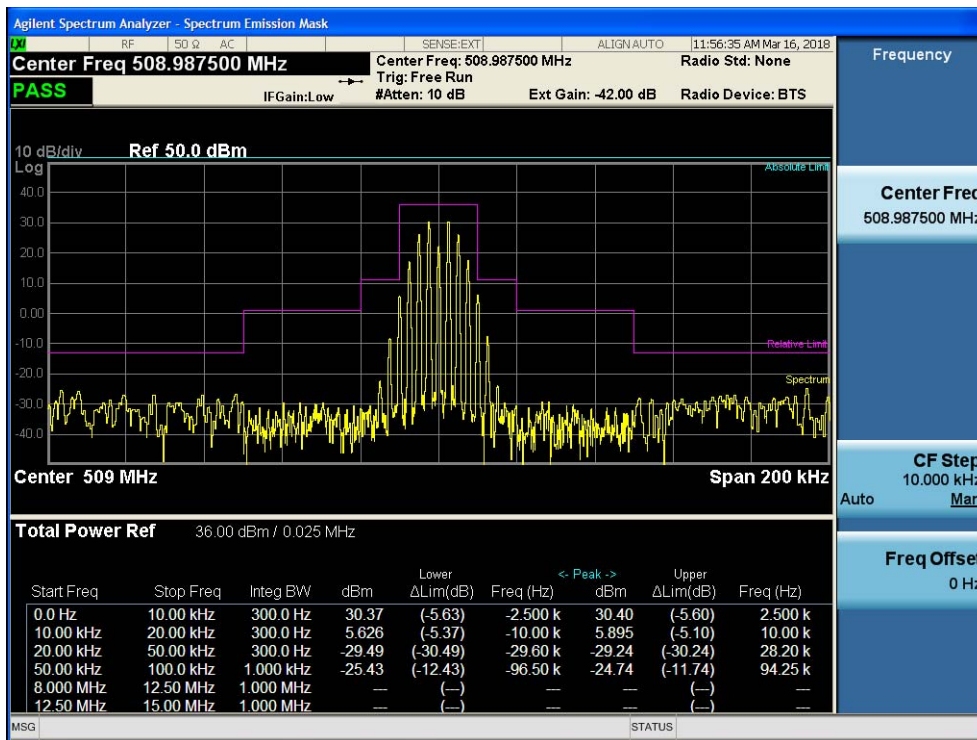

### 1.5 For FM(25k) mode(without audio low pass filter)

#### 1) lowest frequency

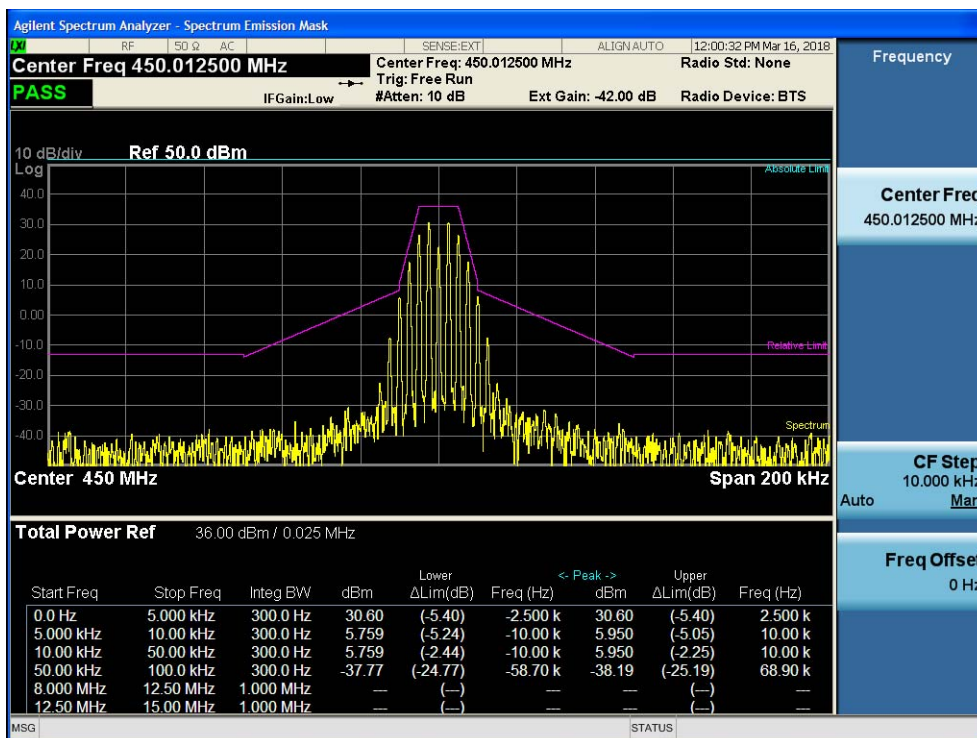



## 2) Middle frequency

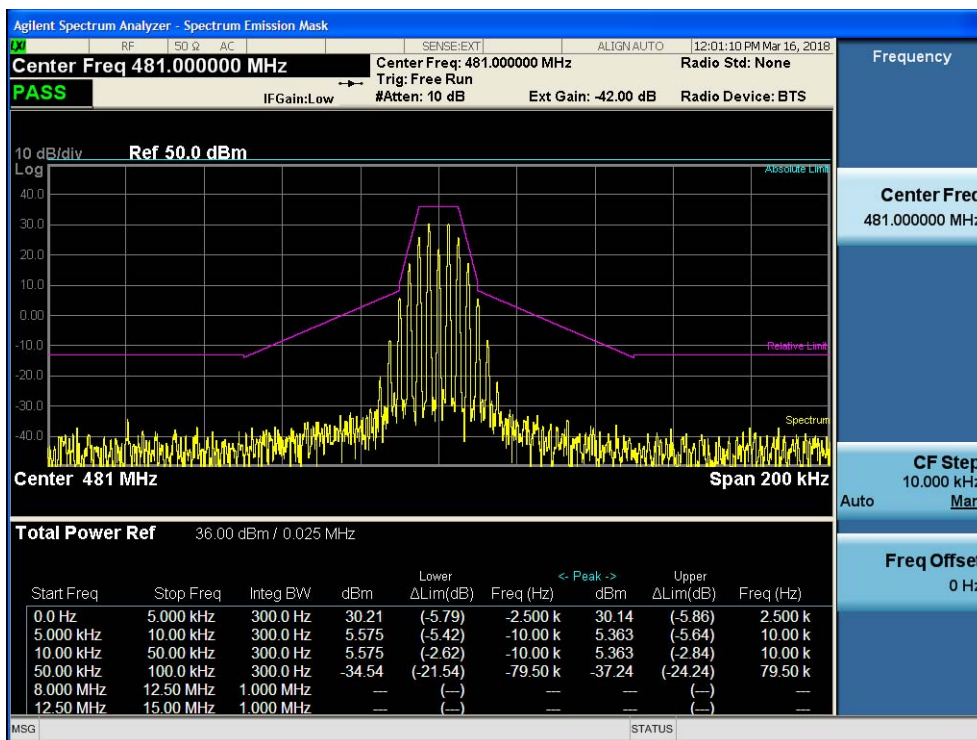

## 3) highest frequency

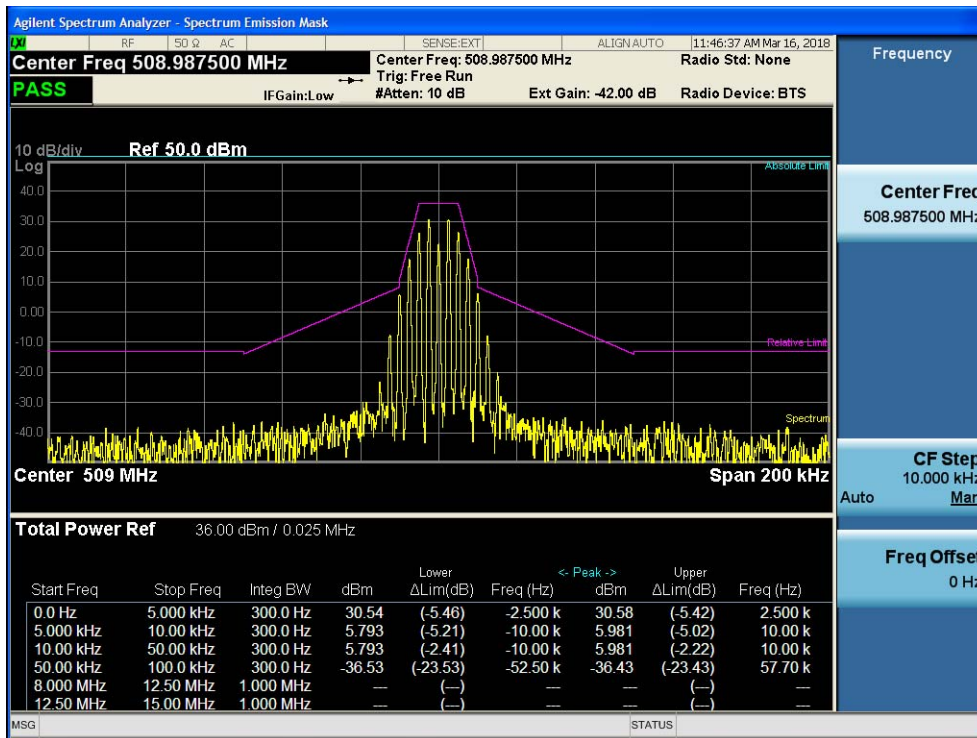



2.Uplink: 455MHz ~ 512MHz

2.1 For C4FM mode:

1)Lowest frequency

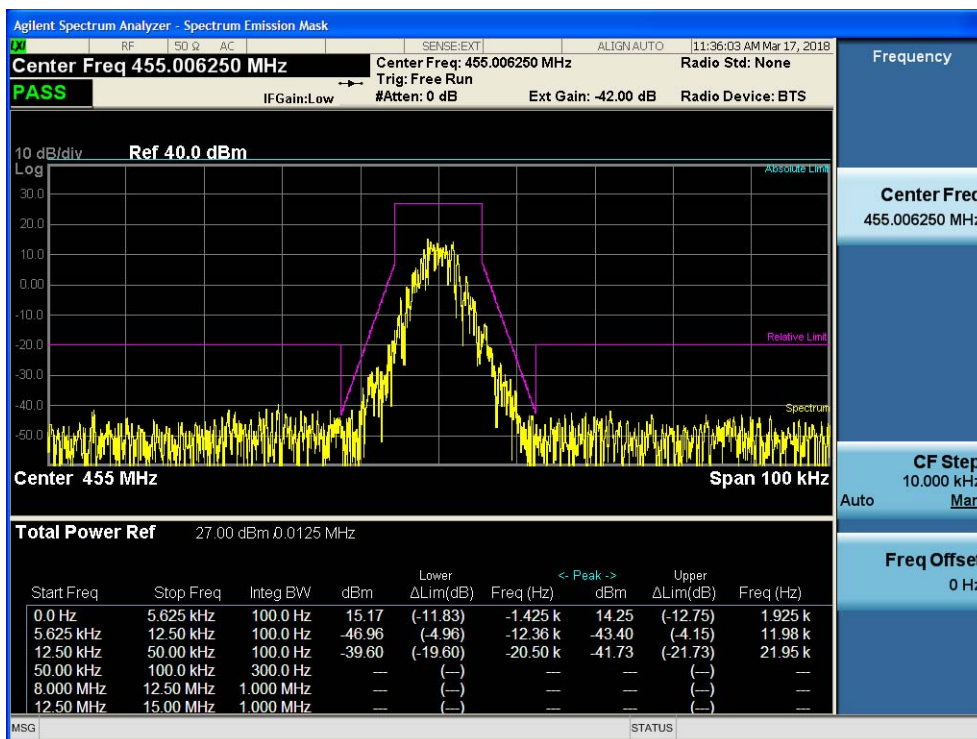

2)Middle frequency

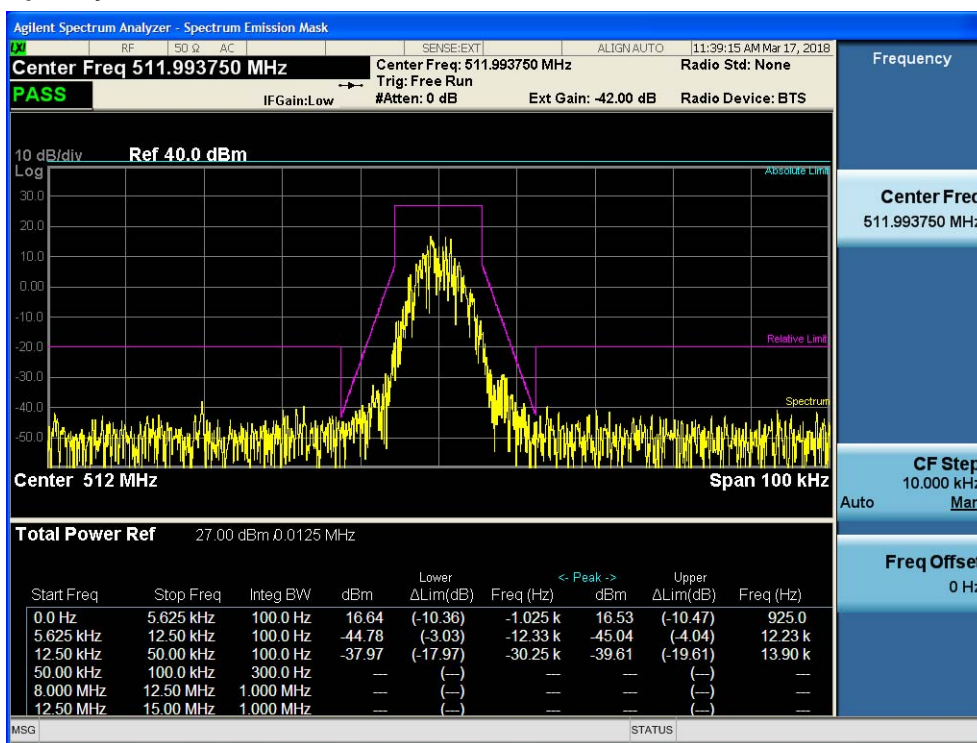



### 3) highest frequency

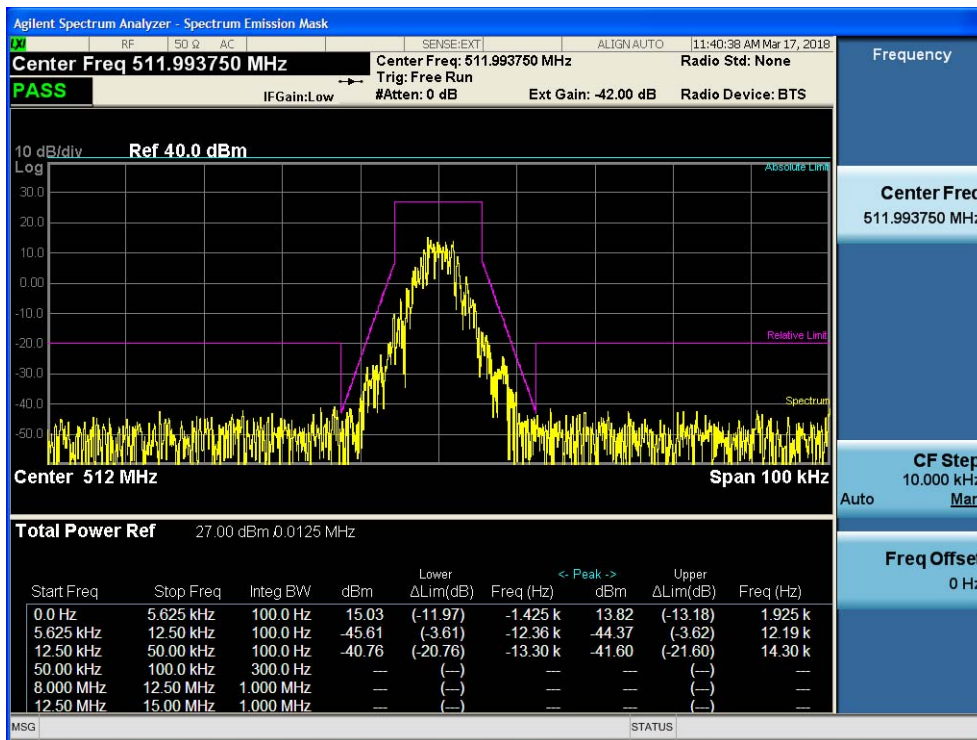

2.2 For FM(6.25k) mode:  
1) lowest frequency

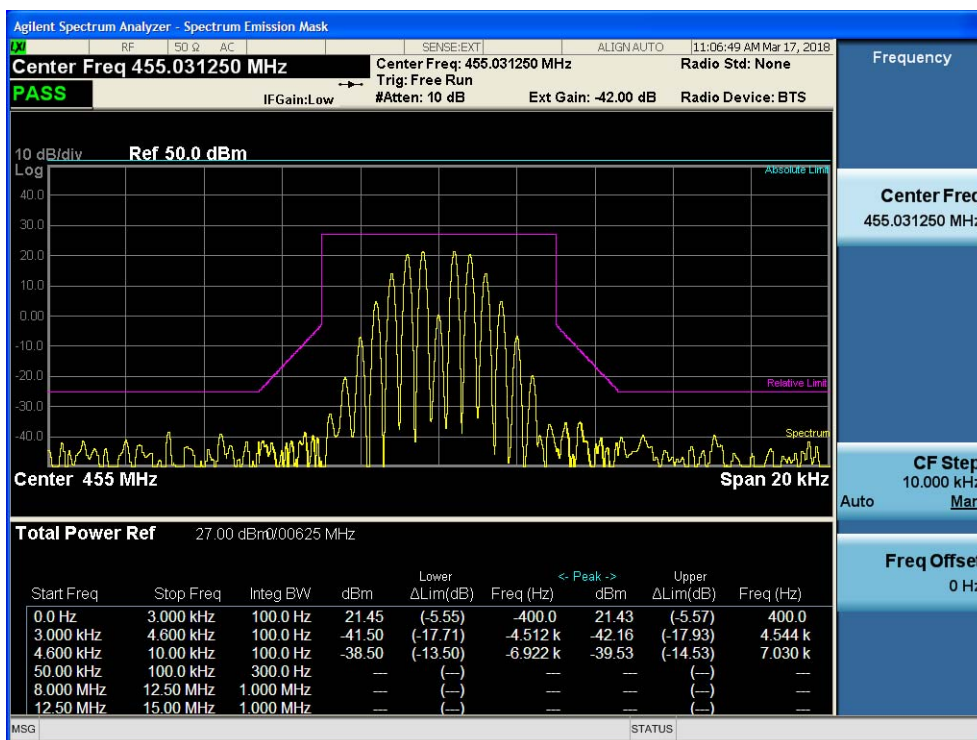

2) Middle frequency

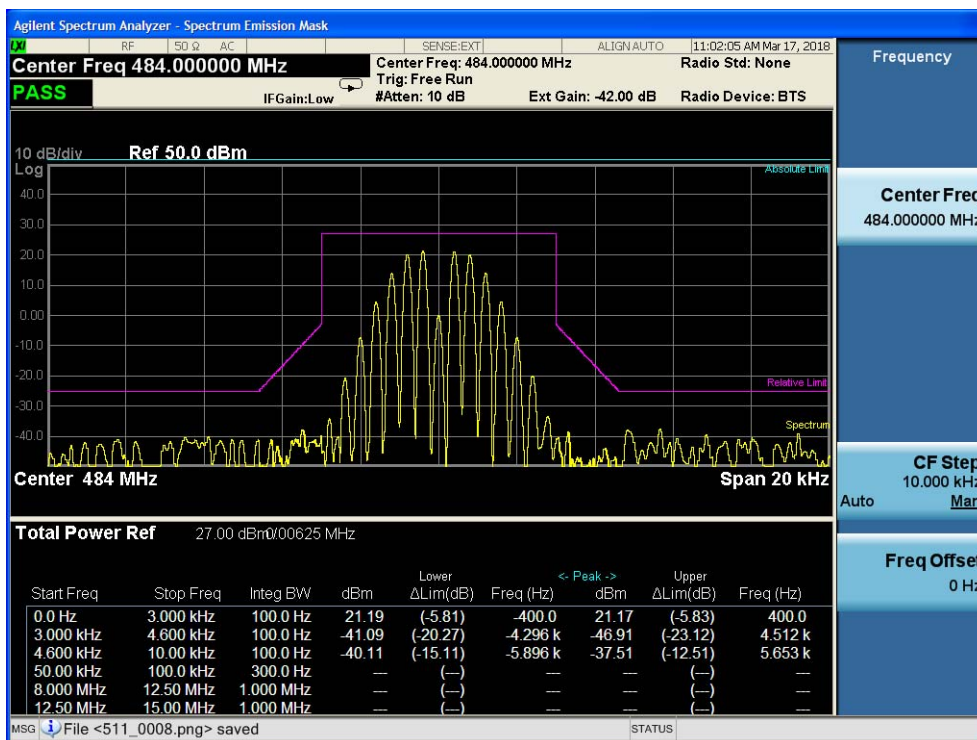





3) highest frequency

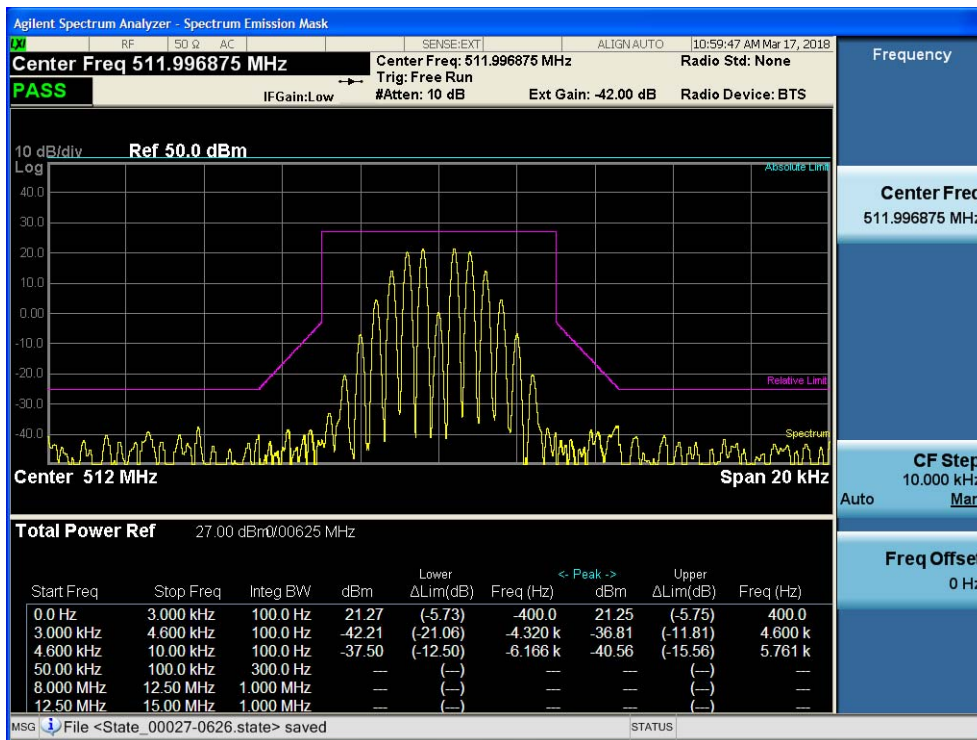

2.3 For FM(12.5k) mode:  
1) lowest frequency

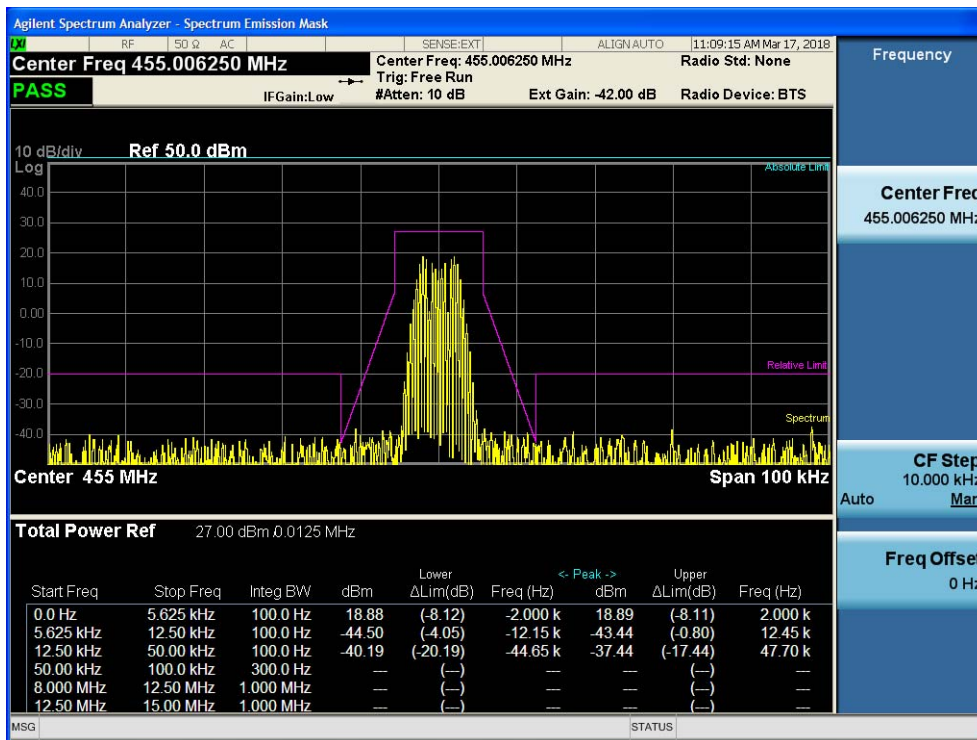

2) Middle frequency

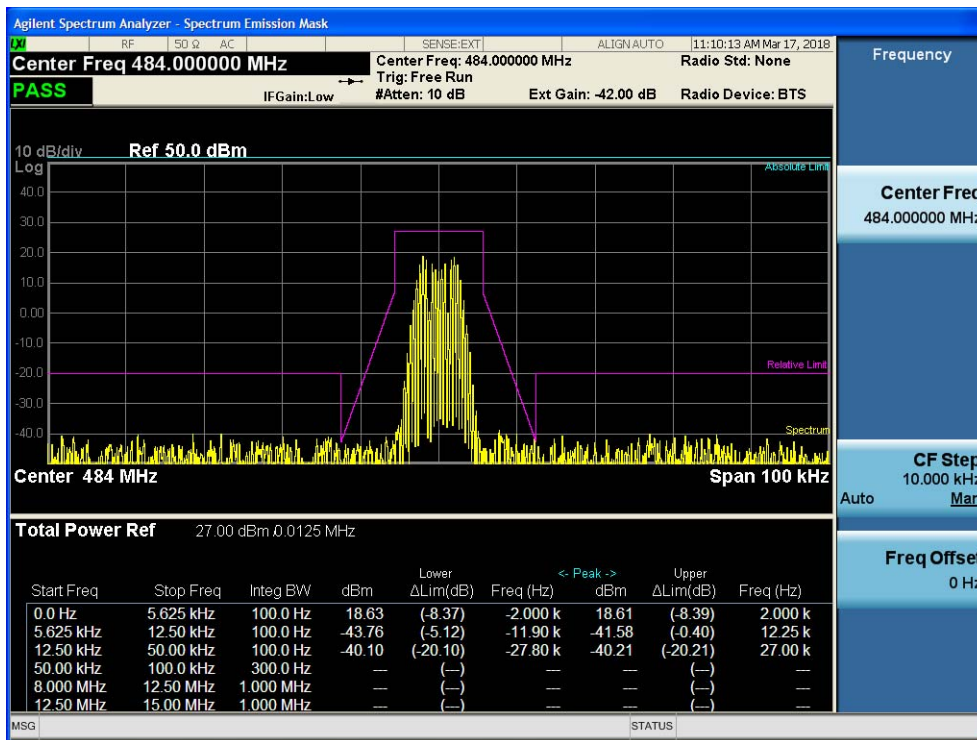

3) highest frequency

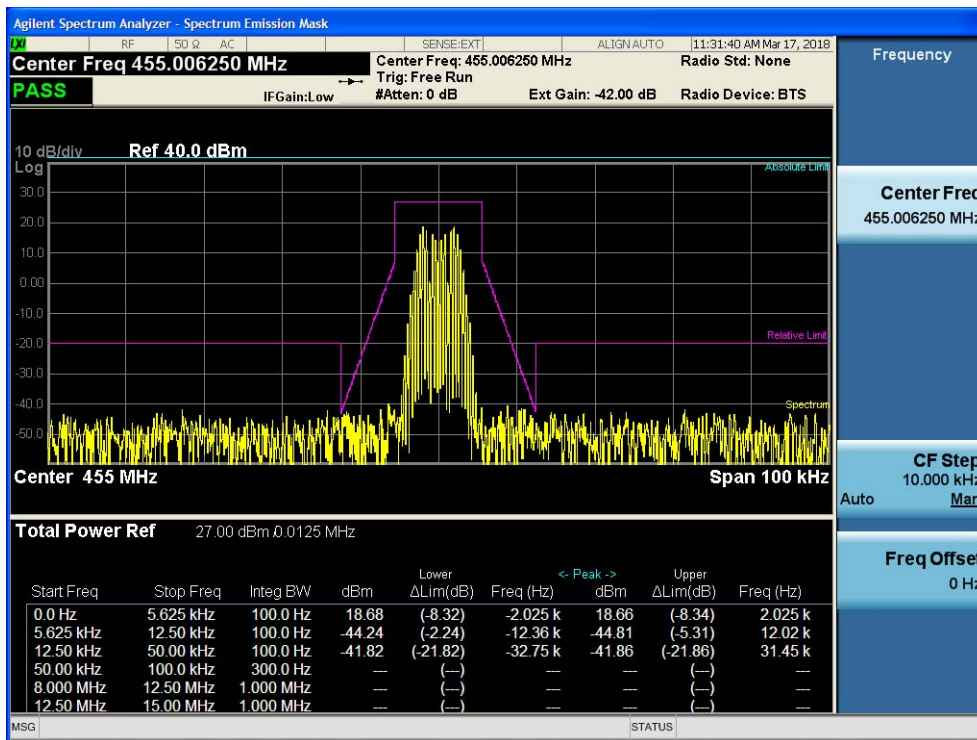

## 2.4 For FM(25k) mode(with audio low pass filter)

### 1) lowest frequency

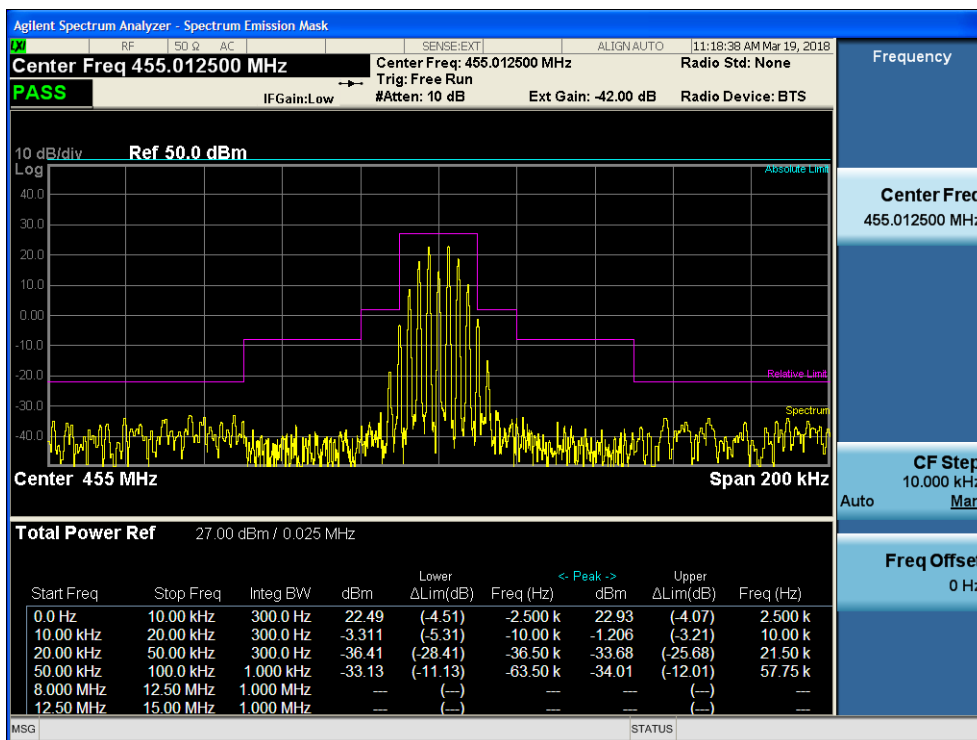

### 2) Middle frequency

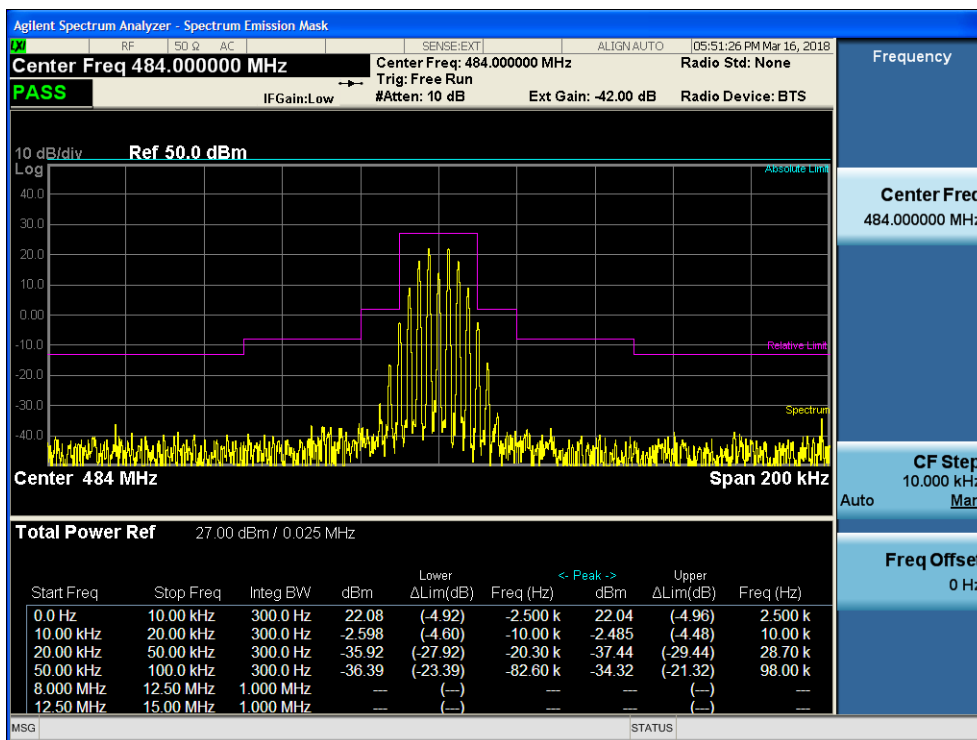

3) highest frequency

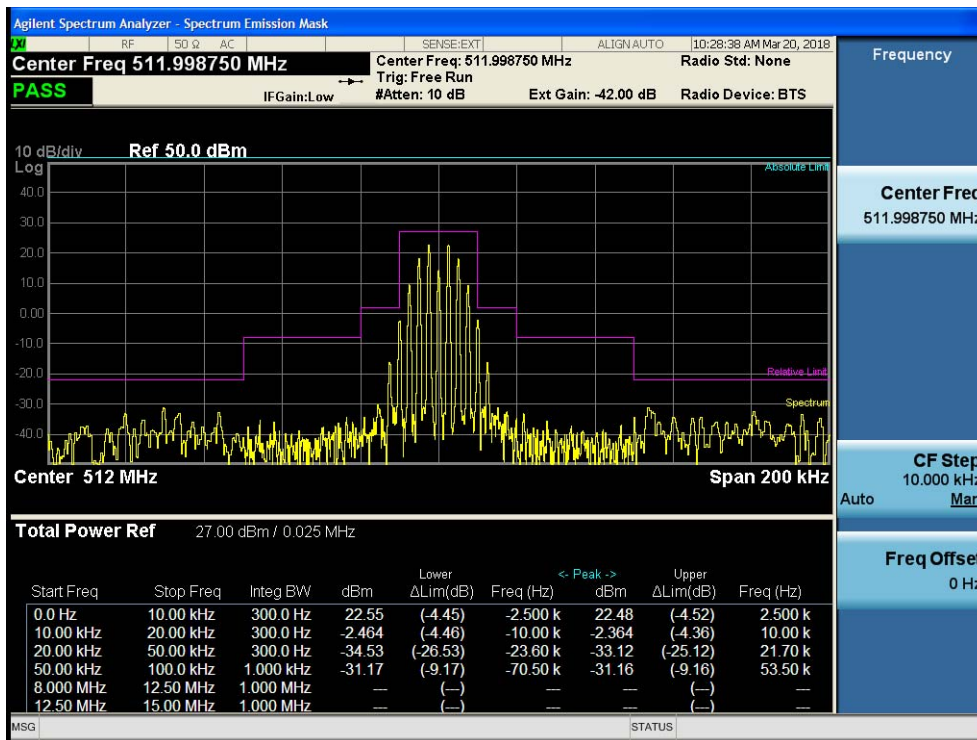

2.5 For FM(25k) mode(without audio low pass filter)  
1 )lowest frequency

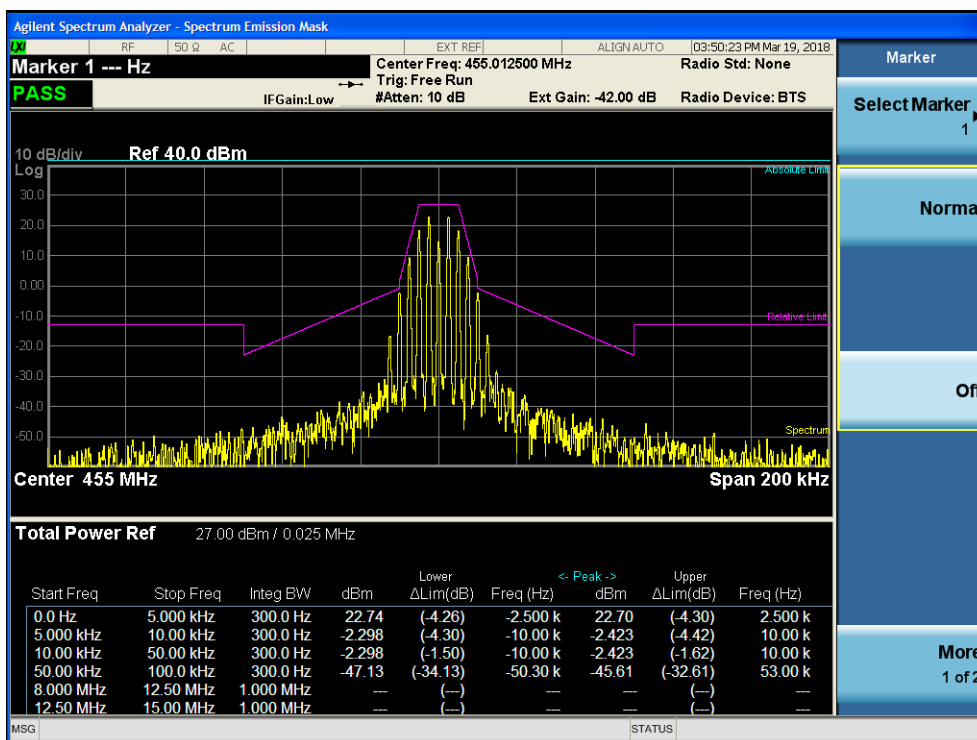

2)Middle frequency

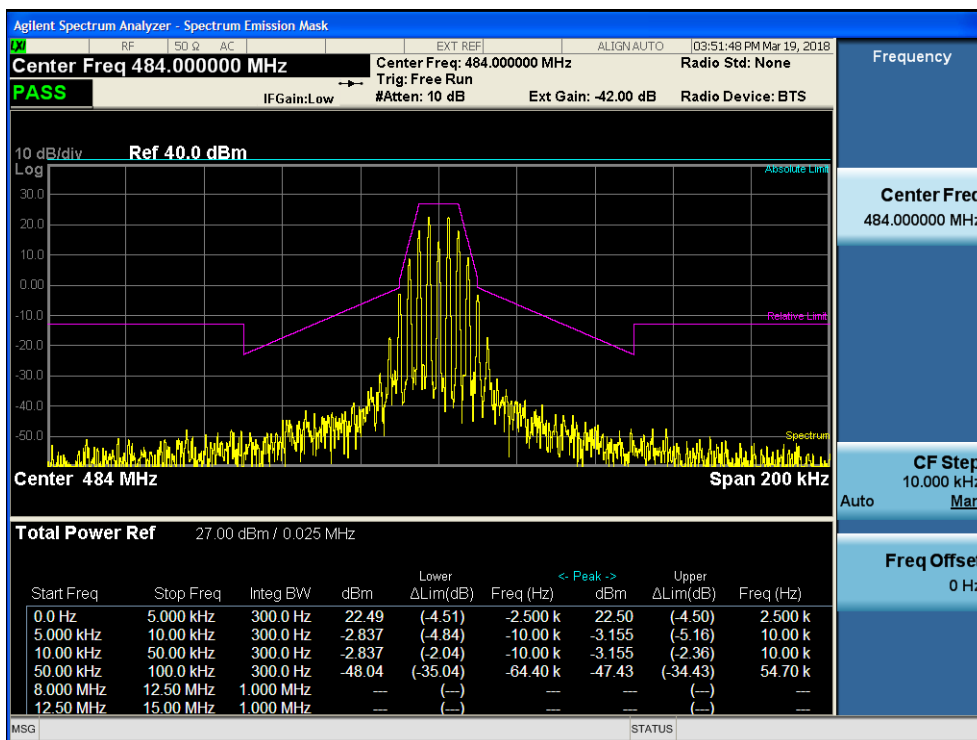





3) highest frequency

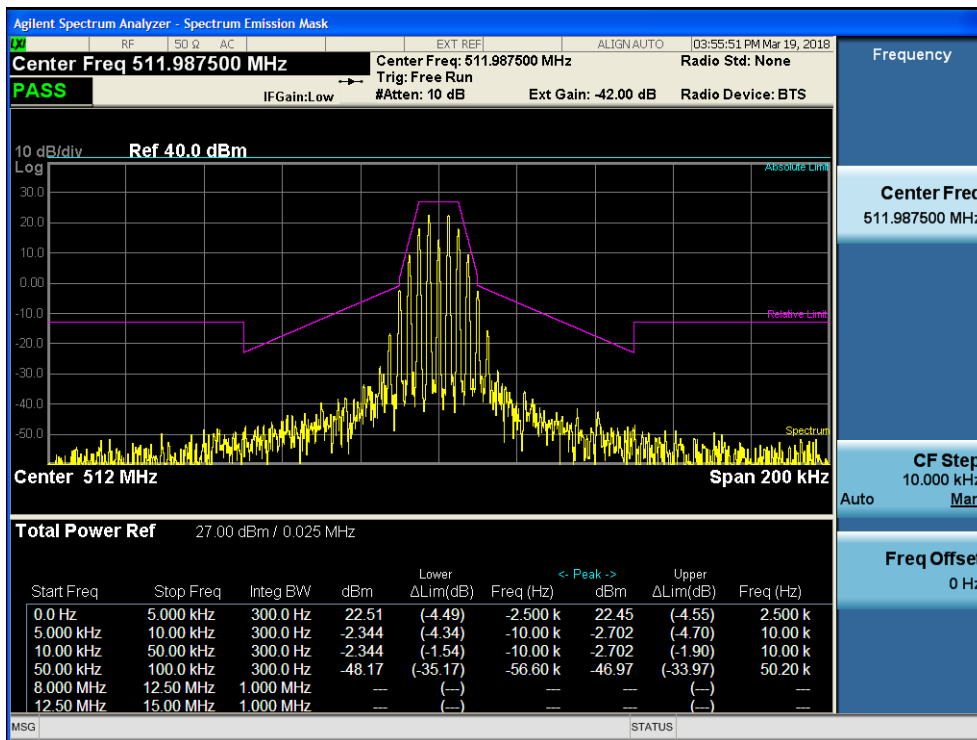

### 7.2.5 Intermodulation & Band edge

Test Requirement: FCC part 90.219 e(3)  
90.219 e(3)

Two signal generators were utilized to produce a two tone signal with two tone signal with the 6.25k/12.5kHz/25kHz channel spacing set so the intermodulation products fell within the operational band.

Limit: (3) Spurious emissions from a signal booster must not exceed -13 dBm within any 100 kHz measurement bandwidth.

Test Method: FCC part 2.1051

EUT Operation:

Status: Drive the EUT to maximum output power. the EUT was pretested at compression and 10dB into compression to show AGC operation, worse case results taken.

Conditions: Normal conditions

Application: Cellular Band RF output ports

Test Configuration:

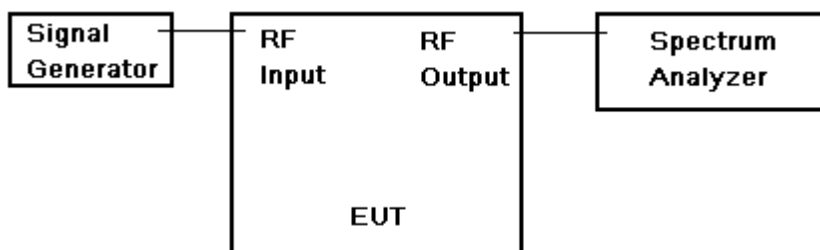

Fig.3. Band edge and Intermodulation test configuration

