

**Nemko Test Report:** 1L0548RUS1

**Applicant:** Advanced Neuromodulation Systems, Inc,  
6501 Windcrest Drive, Suite 100  
Plano, Texas 75024

**Equipment Under Test:  
(E.U.T.)** Genesis System

**In Accordance With:** **FCC Part 15, Subpart C, Paragraph 15.209**  
General Limits For Low Power Transmitters

**Tested By:** Nemko Dallas Inc.  
802 North Kealy  
Dallas, TX 75057

**Authorized By:**



Tom Tidwell, Wireless Group Manager

**Date:** 01/04/2002

**Total Number of Pages:** 15

**Table of Contents**

**SECTION 1. SUMMARY OF TEST RESULTS.....3**

**SECTION 2. GENERAL EQUIPMENT SPECIFICATION .....5**

**SECTION 3. POWERLINE CONDUCTED EMISSIONS .....7**

**SECTION 4. RADIATED EMISSIONS .....8**

**SECTION 5. TEST EQUIPMENT LIST ..... 13**

**ANNEX A - TEST DIAGRAMS..... 14**

*EQUIPMENT:Genesis System*

---

**Section 1. Summary Of Test Results**

Manufacturer: Advanced Neuromodulation Systems, Inc,

Model No.: Genesis System

Serial No.: None

General: **All measurements are traceable to national standards.**

These tests were conducted on a sample of the equipment for the purpose of demonstrating compliance with FCC Part 15, Subpart C for low power devices. All tests were conducted using measurement procedure ANSI C63.4-1992. Radiated Emissions were made on an open area test site.

- |                                     |                            |                                     |                     |
|-------------------------------------|----------------------------|-------------------------------------|---------------------|
| <input checked="" type="checkbox"/> | New Submission             | <input checked="" type="checkbox"/> | Production Unit     |
| <input type="checkbox"/>            | Class II Permissive Change | <input type="checkbox"/>            | Pre-Production Unit |

THIS TEST REPORT RELATES ONLY TO THE ITEM(S) TESTED.

THE FOLLOWING DEVIATIONS FROM, ADDITIONS TO, OR EXCLUSIONS FROM THE TEST SPECIFICATIONS HAVE BEEN MADE.

See " Summary of Test Data".



**NVLAP LAB CODE: 100496-0**

Nemko Dallas Inc. authorizes the above named company to reproduce this report provided it is reproduced in its entirety and for use by the company's employees only.

Any use which a third party makes of this report, or any reliance on or decisions to be made based on it, are the responsibility of such third parties. Nemko Dallas Inc. accepts no responsibility for damages, if any, suffered by any third party as a result of decisions made or actions based on this report.

This report applies only to the items tested.

*EQUIPMENT:Genesis System*

---

**Summary Of Test Data**

<b>NAME OF TEST</b>	<b>PARA. NO.</b>	<b>RESULT</b>
Powerline Conducted Emissions	15.207	N/A
Radiated Emissions	15.209	Complies

**Footnotes For N/A's:**

The device is battery powered. (Qty 3, AAA)

*EQUIPMENT:Genesis System*

---

## Section 2. General Equipment Specification

Frequency Range: 87.5 kHz +/- 2.5 kHz

Operating Frequency(ies) of Sample: 87.3 kHz

Crystal Frequencies: 3.6 MHz

Integral Antenna

Yes

No

*Note: If antenna is not integral to transmitter explain method of attachment and type of unique connector:*

*EQUIPMENT:Genesis System*

---

### Description of Modification for Class II Permissive Change

Not Applicable

### Modifications Made During Testing

Not Applicable

### Theory of Operation

The Genesis™ System is a multi-programmable implantable neurostimulation system designed to deliver low-intensity, electrical impulses to nerve structures. The system consists of a hand-held battery powered patient programmer which communicates to a self-powered implantable pulse generator (IPG). The IPG delivers electrical impulses through an implanted lead(s) to the selected nerve fibers in order to provide therapeutic stimulation. The patient programmer enables the patient to adjust current stimulation parameters and select new programs for customized therapy.

The Genesis Programmer and IPG communicate by modulating a 87.5 kHz +/-2.5 kHz signal for data sent to the IPG and modulating a 40Khz signal for data sent back to the patient programmer. The data is modulated using a standard 2400 Baud RS232 protocol. All of the RF circuitry for the patient programmer is included in the paddle-like device which attaches to the patient programmer called the ‘wand’. The wand must be placed within several inches of the implanted IPG to communicate with it.

For the transmitter section of the wand circuitry, timer circuitry generates a signal which is approximately 87.5 kHz that drives the carrier signal through an airwound inductor that acts as an antenna. The carrier is switched on and off by a signal from the patient programmer such that it meets the RS232 2400 baud timing requirements.

For the receiver section of the wand circuitry, when the wand is in receive mode, the airwound inductor becomes part of a 40Khz LC resonant tank circuit and the received carrier is sent through a two stage 40Khz bandpass circuit where it is then lowpass filtered to recover a 2400 baud logic level signal.

### System Diagram

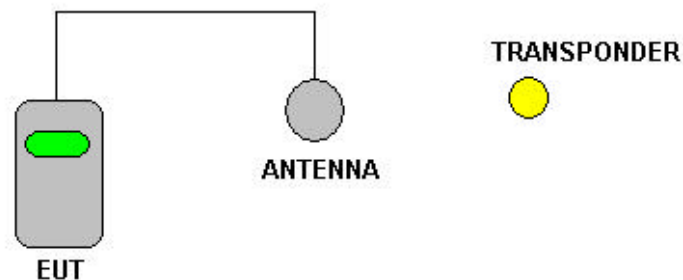

*EQUIPMENT:Genesis System*

**Section 3. Powerline Conducted Emissions**

NAME OF TEST: Powerline Conducted Emissions	PARA. NO.: 15.207
TESTED BY:	DATE:

**Minimum Standard:**

Frequency (MHz)	Maximum Powerline Conducted RF Voltage (dBmV)
0.15 - 0.5	250
0.5 - 1.0	48

**Not Applicable**

**Test Results:** Complies / Does not comply. See attached graph(s).

**Measurement Data:** See attached graph(s).

**Method of Measurement:** (Procedure ANSI C63.4-1992)

Measurements were made using a spectrum analyzer with 10 kHz RBW, Peak Detector. Any emissions that are close to the limit are measured using a test receiver with 10 kHz bandwidth, CISPR Quasi-Peak Detector.

*EQUIPMENT:Genesis System*

---

**Section 4. Radiated Emissions**

NAME OF TEST: Radiated Emissions	PARA. NO.: 15.209
TESTED BY: David Light	DATE: 01/04/2002

**Minimum Standard:** The field strength of emissions from the device shall not exceed the following limits.

Fundamental (MHz)	Field Strength (mV/m)	Field Strength (dBmV)
0.009 - 0.490	2400/F(kHz) @ 300m	—
0.490 - 1.705	24000/F(kHz) @ 30m	—
1.705 - 30	30 @ 30m	—
30 - 88	100	40.0
88 - 216	150	43.5
216 - 960	200	46.0
Above 960	500	54.0

**Test Results:** Complies.

**Measurement Data:** (Procedure ANSI C63.4-1992)

**Tested with fully charged batteries**

**Maximizing Emission Levels:**

For hand held equipment or equipment that may be mounted in a variety of positions, the E.U.T. was tested on three orthogonal axis to determine orientation of worst-case emission levels. Below 30 MHz an active loop antenna is used at a fixed height of 1 meter. The loop is rotated about it's vertical axis to obtain worst-case results.

**Spectrum Searched:**

The spectrum was searched from the lowest frequency generated in the E.U.T. up to 1000 MHz, or the 10<sup>th</sup> harmonic of the fundamental emission.

**Near-Field Measurement:**

Emissions below 30 MHz are measured in the near-field and an extrapolation factor of 40 dB per decade is used to determine the 10m limit.

Example: Measurement Distance = 10m  
 Specification Distance = 300m

10m Limit: Specified limit (at 300m) -  $(40 \text{ Log } \frac{10}{300})$

Thus for measurement at 10m the specified limit is increased by 59 dB.



EQUIPMENT: Genesis System

Test Data - Radiated Emissions



Dallas Headquarters:  
 802 N. Kealy  
 Lewisville, TX 75057  
 Tel: (972) 436-9600  
 Fax: (972) 436-2667

Nemko Dallas, Inc.

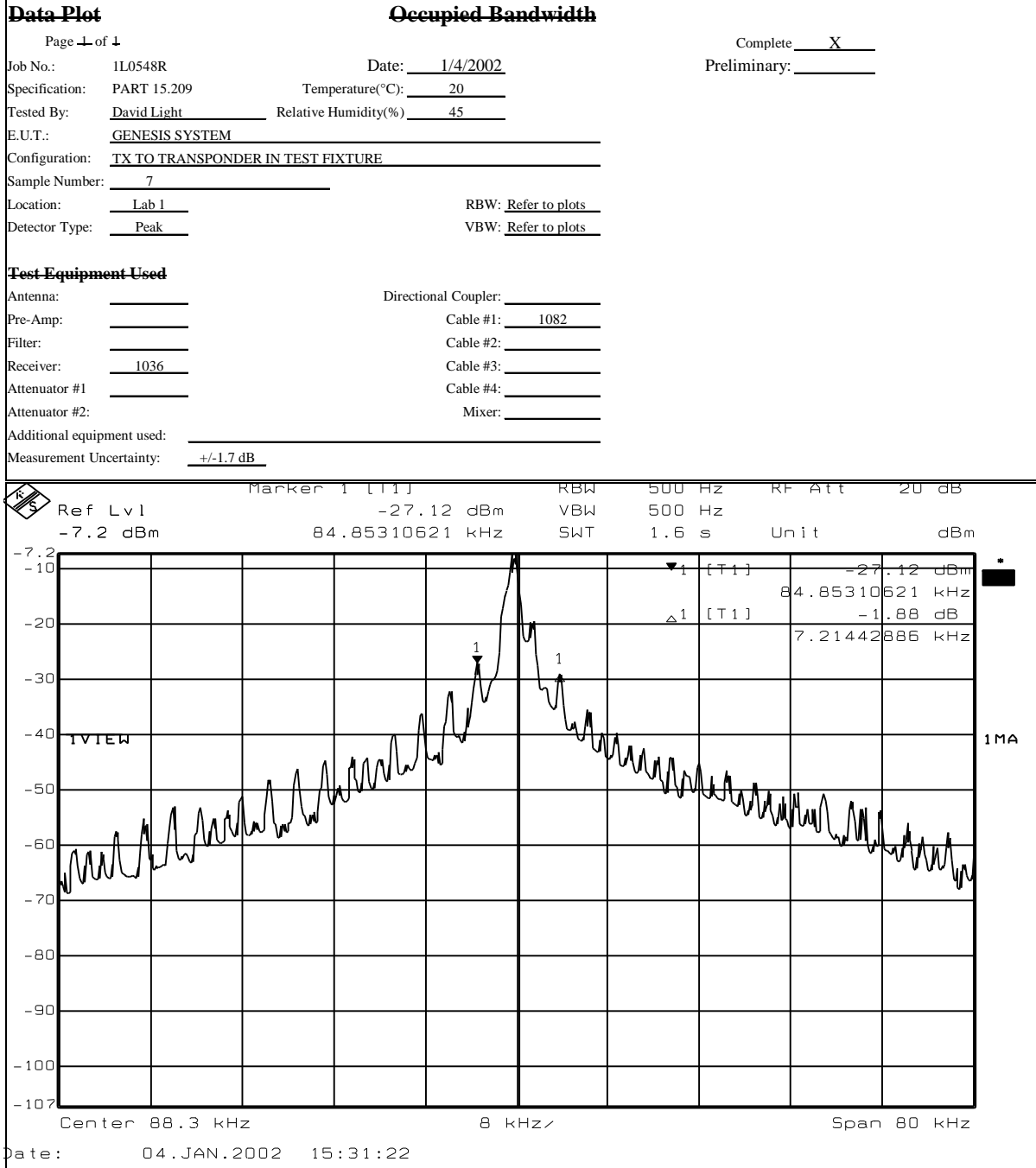

*EQUIPMENT:Genesis System*

**Test Data – Radiated Emissions**



Nemko Dallas, Inc.

802 N. Kealy  
 Lewisville, TX 75057  
 Tel: (972) 436-9600  
 Fax: (972) 436-2667

Radiated Emissions									
Radiated Emissions									
H - Field									
Complete	<input checked="" type="checkbox"/>								
Preliminary	<input type="checkbox"/>								
			Page			1		of 1	
Client:	<u>ANS</u>		W.O.#:	<u>1L0548R</u>		Date:	<u>1/4/2001</u>		
EUT:	<u>GENESIS SYSTEM</u>		S/N:	<u>None</u>					
Tech:	<u>LIGHT</u>		Test #:	<u>3</u>		Lab:	<u>AOATS</u> Photo ID: <u>None</u>		
Equipment Used:	<u>981-966</u>					Antenna Distance:	<u>3 Meters</u>		
Configuration:	<u>Transmitting to transponder in test fixture</u>								
IF Bandwidth:	<u>See below</u>		Video Bandwidth:	<u>N/A</u>		Detector:	<input type="checkbox"/> Peak <input checked="" type="checkbox"/> Quasi Peak		
Ambient Temperature:	<u>2</u> C		EUT Power:	<input type="checkbox"/> 115 V.A.C.		<input type="checkbox"/> 60 Hz		<input type="checkbox"/> 1 Phase	
Relative Humidity:	<u>40</u> %		<input type="checkbox"/> 230 V.A.C.		<input type="checkbox"/> 50 Hz		<input type="checkbox"/> 3 Phase		
			<input checked="" type="checkbox"/> Other		<u>4.5 Vdc (3 AAA Batteries)</u>				

Freq. (MHz)	Meter Reading (dBuV/m)	Antenna Factor (dB)	Cable Loss (dB)	RBW (Hz)	Corrected Reading (dBuV/m)	Spec. Limit (dBuV/m)	Delta (dB)	Comments:
88.3	43	0	0	200	43	108.7	-65.7	
176.6	38	0	0	200	38	102.7	-64.7	
264.9	40	0	0	9k	40	99.1	-59.1	
353.2	36	0	0	9k	36	96.6	-60.6	
441.5	29	0	0	9k	29	94.7	-65.7	
529.8	46	0	0	9k	46	73.1	-27.1	
618.1	29	0	0	9k	29	71.8	-42.8	Noise floor
706.4	34	0	0	9k	34	70.6	-36.6	Noise floor
794.7	41	0	0	9k	41	69.9	-28.9	Ambient
883.0	34	0	0	9k	34	68.7	-34.7	Noise floor

**Scanned 9 kHz to 30 MHz**

*EQUIPMENT:Genesis System*

### Test Data - Radiated Emissions

No emissions were detected above 30 MHz during prescan in an anechoic chamber.

#### Data plot horizontal

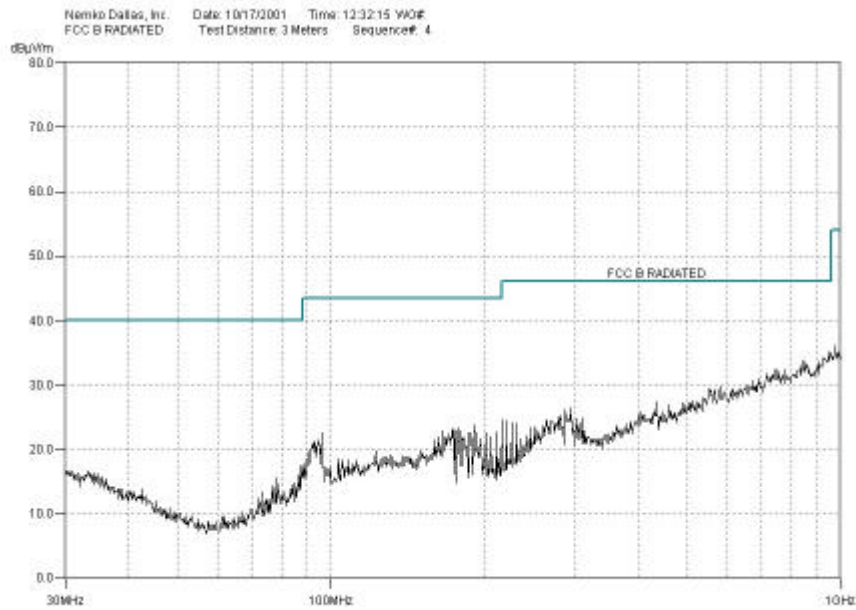

#### Data plot vertical

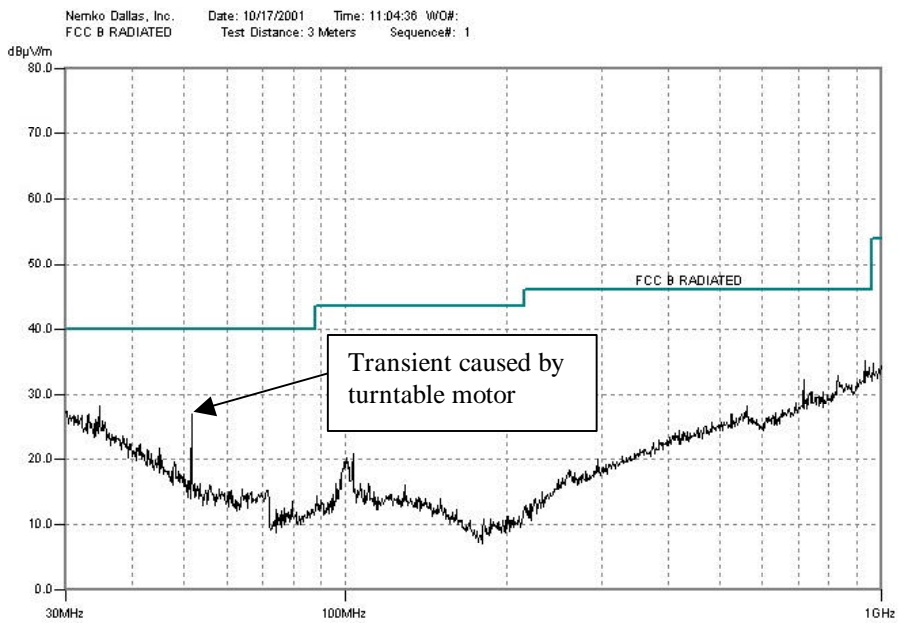

*EQUIPMENT: Genesis System*

---

**Radiated Photographs (Worst Case Configuration)**  
FRONT VIEW



REAR VIEW



*EQUIPMENT:Genesis System*

---

**Section 5. Test Equipment List**

Nemko ID	Description	Manufacturer Model Number	Serial Number	Calibration Date
981	ANTENNA, LOOP	ROHDE & SCHWARZ HFH2-Z2	871336/20	Cal Not Req
966	Receiver	Rohde & Schwartz ESH2	880370/029	06/05/01
1464	Spectrum analyzer	Hewlett Packard 8563E	3551A04428	01/02/01
1484	Cable 2.0-18.0 Ghz	Storm PR90-010-072	N/A	06/01/01
1485	Cable 2.0-18.0 Ghz	Storm PR90-010-216	N/A	06/01/01
791	PREAMP, 25dB	ICC LNA25	398	08/16/01
1480	Bilog Antenna	Schaffner-Chase CBL6111C	2572	CalNotReq

**ANNEX A - TEST DIAGRAMS**

*EQUIPMENT: Genesis System*

---

### Radiated Prescan

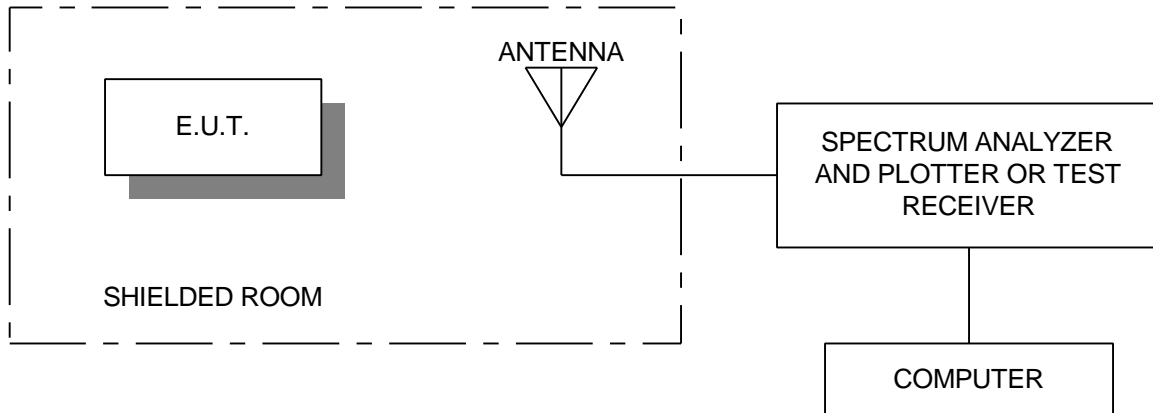

### Test Site For Radiated Emissions

