

1 Package Contents / 包装内容 / 包装内容

Kindly ensure the product's contents upon unpacking; please refer to this quick start guide regarding the product's specifications and important notices. The items described below are the standard packaging.

打开包装确认产品包装内容, 并详细阅读此手册, 认识产品规格特性与注意事项。产品包装内容与数量依产品别而略有不同, 实际内容以产品包装物为准。

打開包裝確認產品包裝內容, 並請詳細閱讀此手冊, 認識產品規格特性與注意事項。產品包裝內容與數量依產品別而略有不同, 實際內容以產品包裝物為準。

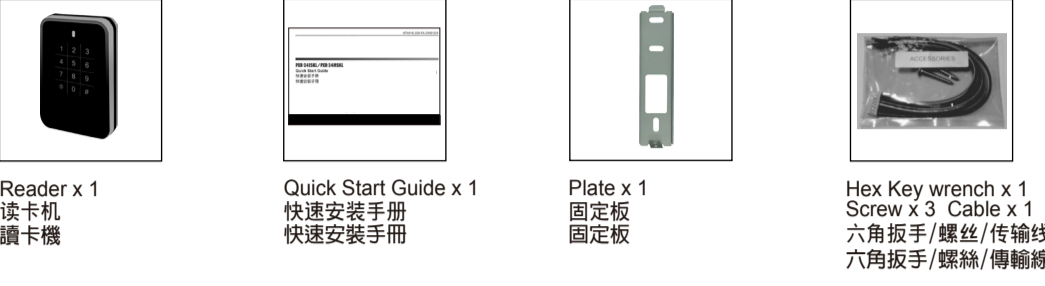

2 Physical Dimension / 外观尺寸 / 外觀尺寸

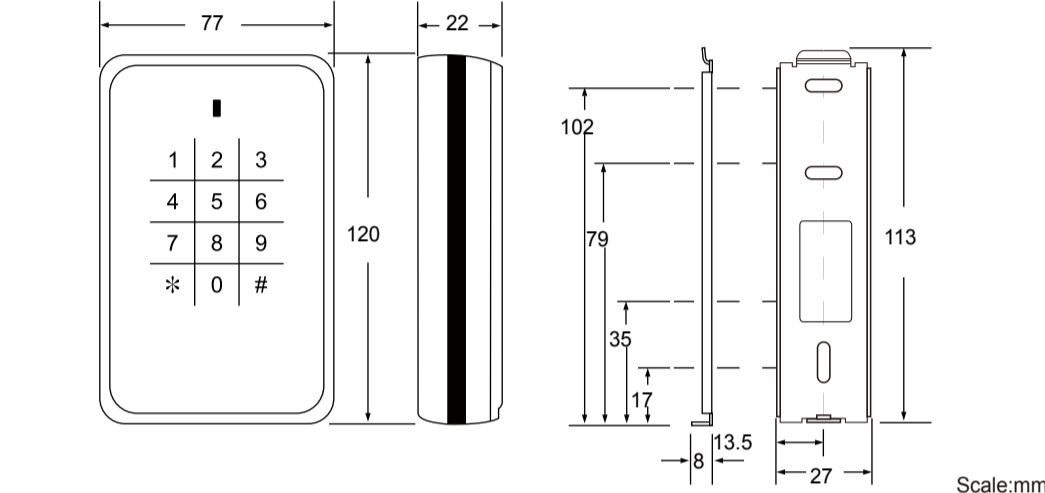

3 Installation / 安装 / 安裝

- Kindly refer to the "[4] wiring connections" before the hardware installation.
- Do not over tighten the back plate screws during installation to prevent distortion.

(A). Mount the back plate onto the wall or electrical back box (120 type, American spec.).

(B). Connect the wires in accordance with the wiring instruction below.

(C). Make sure the back plate and the reader upper cover guides are aligned.

(D). Install the reader upper cover to the back plate.

(E). Use the hex key wrench to fasten the screw onto the bottom of the reader.

(F). Tear off the protective film.

• 安裝前請先參考 "[4] 接線"。

• 安裝讀卡機固定板時, 請勿用力過大以避免造成彎曲變形。

(A). 將安裝固定板固定在牆上或美規120預埋盒。

(B). 依照接線說明將線接上, 並將各接線端子插上。

(C). 讀卡機上方對準固定板卡榫。

(D). 將讀卡機往固定板方向密合。

(E). 使用六角扳手將螺絲由下方底部密合鎖上。

(F). 請撕掉保護膜。

• 安裝前請先參考 "[4] 接線"。

• 安裝讀卡機固定板時, 請勿用力過大以避免造成彎曲變形。

(A). 將安裝固定板固定在牆上或美規120預埋盒。

(B). 依照接線說明將線接上, 並將各接線端子插上。

(C). 讀卡機上方對準固定板卡榫。

(D). 將讀卡機往固定板方向密合。

(E). 使用六角扳手將螺絲由下方底部密合鎖上。

(F). 請撕掉保護膜。

4 Wiring Connections / 接线 / 接線

Before mounting the reader onto desired location. Please set the NODE ID (DIP Switch, binary number system). The position of the components varies according to the reader's model. Kindly take note of the components during setup. 調整讀卡機 NODE ID 請打開後蓋的螺絲, 零件位置如下圖示意, 請依實際零件位置做參考。調整讀卡機 NODE ID 請打開後蓋的螺絲, 零件位置如下圖示意, 請依實際零件位置做參考。

NODE ID Settings, refer to the chart below.
讀卡機NODE ID, 請依照下表做配置
讀卡機NODE ID, 請依照下表做配置

Node ID	Configuration/开关位址/開關位址
0	00000
1	10000
2	01000
3	11000
4	00100
5	10100
6	01100
7	11100
8	00010
9	10010
10	01010
11	11010
12	00110
13	10110
14	01110
15	11110

ON=1, OFF=0

Dip(6)

- Dip(6) is card format selection. ON is for reading the document, and OFF is for reading the serial number.
- Dip(6) 是卡片格式選擇。ON 為讀取文檔, OFF 為讀取序號。
- Dip(6) 是卡片格式選擇。ON 為讀取文檔, OFF 為讀取序號。

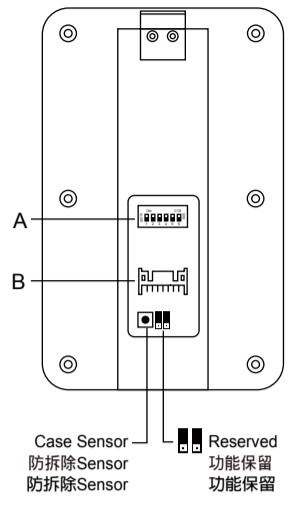

Pin	Color	Wiegand	RS-485
1	Red/紅/紅	DC+12V IN	DC+12V IN
2	Black/黑/黑	Ground	Ground
3	Yellow/黃/黃	-	RS-485+
4	Blue/藍/藍	-	RS-485-
5	Gray/灰/灰	OP1(Reserved)	-
6	Pink/粉紅/粉紅	-	-
7	Orange & White 橙白/橙白	Ground	-
8	Orange/橙/橙	-	-
9	Brown/棕/棕	Green LED Control	-
10	Purple/紫/紫	Beep Control	-
11	White/白/白	Case Sensor GND (To Controller GND)	-
12	Green/綠/綠	Case Sensor (To Controller Case Sensor)	-
13	Red & White 紅白/紅白	* W0	-
14	Gray & White 灰白/灰白	* W1	-

*Do not use the same set of twisted pairs. 不可使用同一組雙絞線。不可使用同一組雙絞線。

- Note:
- Kindly use minimum 22AWG double-shielded aluminum mylar foil twisted pair cable for the connection between the reader and the controller.
 - In order to reduce long distance noise, The isolated net of transmission cable should connect to both ends of device ground.
 - The distance between two readers should be over 30cm to prevent radio frequency interference from each other.
 - Mounting the device around metal could affect read range. Metal of any type around the device should be avoided while mounting.
 - The distance between the reader and the controller should not exceed 30 meters. (For wiegand/T2 mode only)
 - For optimum read range, kindly use DC Linear power adaptor for the reader's power supply.
 - In order to ensure the reader's normal operation, input voltage should be between 12V±10%.
 - If the reader is installed in an open area or highly humid environment, it is recommended to protect the reader with an external shielding cover.

- 备注:
- 读卡机与控制器之间请使用22AWG以上的双隔离网铝箔麦拉对绞传输线。
 - 为了减低远距离杂讯, 传输线的隔离网地应接两端装置的地。
 - 建议两个读卡机之间的距离最少30公分以上。
 - 避免安装在金属物周边, 以免影響感應距離。
 - 读卡机与控制器的距離建議不要超過30米。(仅供Wiegand/T2機型用)
 - 供应读卡机之电源, 建议使用非交换式的线性直流电源, 以确保得到最佳的感應距離。
 - 为确保读卡机的正常运作, 输入电源請確保在12V±10%之間。
 - 如安装在露天或高湿度易渗水的环境, 建议另行加装防水罩。

- 備註:
- 讀卡機與控制器之間請使用22AWG以上的雙隔離網鋁箔麥拉對絞傳輸線。
 - 為了減低遠距離雜訊, 傳輸線的隔離網地應接兩端裝置的地。
 - 建議兩個讀卡機之間的距離最少30公分以上。
 - 避免安裝在金屬物週邊, 以免影響感應距離。
 - 讀卡機與控制器的距離建議不要超過30米。(僅供Wiegand/T2機型用)
 - 供應讀卡機之電源, 建議使用非交換式的線性直流電源, 以確保得到最佳的感應距離。
 - 為確保讀卡機的正常運作, 輸入電源請確保在12V±10%之間。
 - 如安裝在露天或高濕度易滲水的環境, 建議另行加裝防水罩。



RS-485/WIEGAND PROXIMITY READER
GV-RKD1352
Quick Start Guide
快速安裝手冊
快速安裝手冊
Ver. 1.0

One Year Limited Warranty / 产品保固证明书 / 產品保固證明書

We warrants this product against defect in material or workmanship for 1 year from the date of purchase. If such a defect is discovered within this warranty limitation, contact your direct vendor for repair or replacement of your unit. When returning the product, you must ship the product in its original packaging or packaging that gives an equal degree of protection. This warranty becomes invalid if the factory-supplied serial number has been removed or altered on the product. This warranty does not cover cosmetic damage or damage due to acts of God, accident, misuse, abuse, negligence or modification of any part of the product. This warranty does not cover damage due to improper operation or maintenance, connection to improper equipment, or attempted repair by anyone other than We. In no event shall We liability exceed the price paid for the product from direct, indirect, special, incidental, or consequential, damages resulting from the use of the product the product, its accompanying software, or it's documentation. We makes no warranty or representation expressed, implied, or statutory, with respect to its products, contents of use of this documentation and all accompanying software, and specially disclaims its quality, performance, merchantability or fitness for any particular purpose. We reserves the right to revise or update its product, software or documentation without obligation to notify any individual or entity.

我們保固此產品於購買日起一年之內因為材料上或是生產製造中所產生的缺陷, 所造成的外觀上, 或是功能上的缺陷及故障問題。若是您在此保固期限之內發現此類問題, 請聯絡本公司的服務人員, 退回此產品, 我們將替您免費維修或是更換產品。當您退回此產品時, 請依照原始的包裝方式包裝此產品, 或是給予同等級的包裝保護; 若是我們收到此產品時, 產品上沒有出廠時的序號標籤, 或是產品已經拆開或與出廠時有任何不同, 這個保固將變得無效。此保固不包含天然的, 以及人為的破壞或改變, 或是意外事故、不正常操作、誤用、濫用等外在因素所造成的損壞。此保固不包含不當的操作或保養, 不當的連結至其他設備, 或是由本公司以外的人員企圖修復此產品。起因為使用這種產品, 在間接、特別、次要因素, 或者隨之發生, 造成伴隨著軟件或其他文檔的損害, 本公司的責任在任何情況下都不得超過這產品的售價。關於產品的軟件和文檔編制的全部內容, 本公司並沒有表示保證或法定它的性能、暢銷性、或者適用於任何特別的目的。本公司保留權利修正或者不斷改進它的產品, 軟件或者文檔編制無義務通知任何個人或者購買者。

我們保固此產品於購買日起一年之內因為材料上或是生產製造中所產生的缺陷, 所造成的外觀上, 或是功能上的缺陷及故障問題。若是您在此保固期限之內發現此類問題, 請聯絡本公司的服務人員, 退回此產品, 我們將替您免費維修或是更換產品。當您退回此產品時, 請依照原始的包裝方式包裝此產品, 或是給予同等級的包裝保護; 若是我們收到此產品時, 產品上沒有出廠時的序號標籤, 或是產品已經拆開或與出廠時有任何不同, 這個保固將變得無效。此保固不包含天然的, 以及人為的破壞或改變, 或是意外事故、不正常操作、誤用、濫用等外在因素所造成的損壞。此保固不包含不當的操作或保養, 不當的連結至其他設備, 或是由本公司以外的人員企圖修復此產品。起因為使用這種產品, 在間接、特別、次要因素, 或者隨之發生, 造成伴隨著軟件或其他文檔的損害, 本公司的責任在任何情況下都不得超過這產品的售價。關於產品的軟件和文檔編制的全部內容, 本公司並沒有表示保證或法定它的性能、暢銷性、或者適用於任何特別的目的。本公司保留權利修正或者不斷改進它的產品, 軟件或者文檔編制無義務通知任何個人或者購買者。

Model / 型号 / 型號	Serial no. / 序号 / 序號	Date of Purchase / 购买日期 / 購買日期	Reseller stamp / 经销商 / 經銷商

Warranty will be valid only after filling out this form and stamped or signed by reseller!
此保固书必須填寫各項內容, 並且蓋有經銷商印蓋始為有效。
此保固書必須填寫各項內容, 並且蓋有經銷商印蓋始為有效。

5 Testing / 测试 / 測試

To avoid interference self-detection of sensitive touch keypad, please do not touch the keypad when input power.
触摸按键机种安装送电时, 需注意勿碰触到按键, 以免按键误动作。
觸摸按键機種安裝送電時, 需注意勿碰觸到按键, 以免按键誤動作。

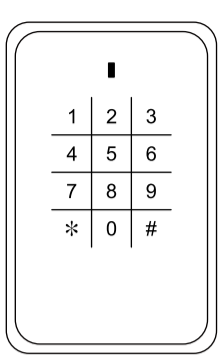

When the power is on, the reader's green LED will flash and the reader will beep concurrently.

打开电源亮绿色灯闪烁, 同时听到“哔”声提示。
打開電源亮綠色燈閃爍, 同時聽到“哔”聲提示。

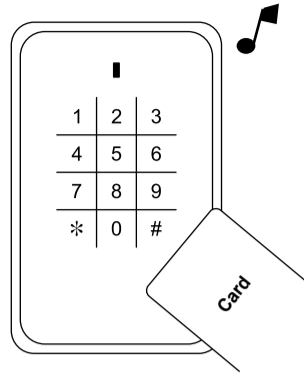

Place the card provided near the reader. The reader will beep concurrently.

將卡片靠近讀卡機, 同時聽到“哔”聲提示。

將卡片靠近讀卡機, 同時聽到“哔”聲提示。

Federal Communication Commission Interference Statement

This equipment has been tested and found to comply with the limits for a Class B digital device, pursuant to Part 15 of the FCC Rules. These limits are designed to provide reasonable protection against harmful interference in a residential installation.

This equipment generates, uses and can radiate radio frequency energy and, if not installed and used in accordance with the instructions, may cause harmful interference to radio communications. However, there is no guarantee that interference will not occur in a particular installation. If this equipment does cause harmful interference to radio or television reception, which can be determined by turning the equipment off and on, the user is encouraged to try to correct the interference by one of the following measures:

- . Reorient or relocate the receiving antenna.
- . Increase the separation between the equipment and receiver.
- . Connect the equipment into an outlet on a circuit different from that to which the receiver is connected.
- . Consult the dealer or an experienced radio/TV technician for help.

FCC Caution: To assure continued compliance, any changes or modifications not expressly approved by the party responsible for compliance could void the user's authority to operate this equipment. (Example - use only shielded interface cables when connecting to computer or peripheral devices).

This device complies with Part 15 of the FCC Rules. Operation is subject to the following two conditions:

- (1) This device may not cause harmful interference, and
- (2) This device must accept any interference received, including interference that may cause undesired operation.