



Compliance Testing, LLC

Previously Flom Test Lab

EMI, EMC, RF Testing Experts Since 1963

toll-free: (866) 311-3268

fax: (480) 926-3598

<http://www.ComplianceTesting.com>

info@ComplianceTesting.com

Test Report

Prepared for: Wilson Electronics, LLC (weBoost)

Model: Enterprise 4300 Series (4 inside ports rack mount)

Description: Quint Band Signal Booster

FCC ID: PWO460053

ISED: 4726A-460053

To

FCC Part 20

ISED RSS-131 (Issue 3)

Date of Issue: June 2, 2019

On the behalf of the applicant:

Wilson Electronics, LLC (weBoost)
3301 E Deseret Drive
St. George, UT 84790

To the attention of:

Phil Weaver, Senior IP and Compliance Engineer
Ph: (435)673-5021
Email: pweaver@weboost.com

Prepared By
Compliance Testing, LLC
1724 S. Nevada Way
Mesa, AZ 85204
(480) 926-3100 phone / (480) 926-3598 fax
www.compliancetesting.com
Project No: p1940016.2



Greg Corbin
Project Test Engineer

This report may not be reproduced, except in full, without written permission from Compliance Testing.
All results contained herein relate only to the sample tested.

Test Report Revision History

Revision	Date	Revised By	Reason for Revision
1.0	June 2, 2019	Greg Corbin	Original Document
2.0	June 21, 2019	Greg Corbin	Added Table of Annexes on page 4

Table of Contents

<u>Description</u>	<u>Page</u>
Standard Test Conditions and Engineering Practices	6
Test Result Summary	9
Authorized Frequency Band	10
Maximum Power and Gain	11
Intermodulation	32
Out-of-Band Emissions	38
Conducted Spurious Emissions	44
Noise Limits	56
Uplink Inactivity	62
Variable Gain	63
Occupied Bandwidth	67
Anti-Oscillation	68
Oscillation Mitigation	74
Radiated Spurious (with modem TX on)	107
Conducted Spurious Emissions with Modem Transmitting	109
Intermodulation with Modem Transmitting	111
Isolation	114
Measurement Uncertainty	116
Test Equipment Utilized	117

Table of Annexes

<u>Description</u>	<u>Page</u>
Annex A Authorized Frequency Band	10
Annex B Intermodulation	37
Annex C Out of Band Emission	43
Annex D Conducted Spurious Emission	55
Annex E Noise Limits and Uplink Noise Timing	59
Annex F Uplink Inactivity	62
Annex G Uplink Gain Timing	66
Annex H Occupied Bandwidth	67
Annex I Anti-Oscillation	73
Annex J Radiated Spurious Emission	108
Annex K Conducted Spurious Emission with the cellular modem transmitting	110
Annex L 3 Tone Intermodulation	113
Annex M Isolation	115

ILAC / A2LA

Compliance Testing, LLC, has been accredited in accordance with the recognized International Standard ISO/IEC 17025:2005. This accreditation demonstrates technical competence for a defined scope and the operation of a laboratory quality management system (refer to the joint ISO-ILAC-IAF Communiqué dated January 2009).

The tests results contained within this test report all fall within our scope of accreditation, unless noted below.

Please refer to <http://www.compliancetesting.com/labscope.html> for current scope of accreditation.

Testing Certificate Number: **2152.01**



FCC Site Reg. #349717

IC Site Reg. #2044A-2

Non-accredited tests contained in this report:

N/A

Test and Measurement Data

Sub-part 2.1033(c)(14):

All tests and measurement data shown were performed in accordance with FCC Rules and Regulations, Part 2, Subpart J and the following individual Parts: 20.21 in conjunction with latest version of KDB 935210.

Standard Test Conditions and Engineering Practices

Except as noted herein, the following conditions and procedures were observed during the testing:

In accordance with ANSI/C63.4-2014, and unless otherwise indicated in the specific measurement results, the ambient temperature of the actual EUT was maintained within the range of 10° to 40°C (50° to 104°F), unless the particular equipment requirements specified testing over a different temperature range. Also, unless otherwise indicated, the humidity levels were in the range of 10% to 90% relative humidity.

Environmental Conditions		
Temp (°C)	Humidity (%)	Pressure (mbar)
23.1 – 27.9	26.7 – 41.3	958.4 – 970.2

Measurement results, unless otherwise noted, are worst-case measurements.

EUT Description

Model: Enterprise 4300 460053

Description: Quint Band Signal Booster

Firmware: A460053A

Software: 460053A

Serial Number: 460053C0114721217

Additional Information:

The EUT is an In-Building bi-directional amplifier for the boosting of cellular phone signals and data communication devices.

The EUT has 4 server ports and 3 donor ports and an internal cellular modem. A more detailed description of the server ports, donor ports, and cellular modem are after the frequency band information.

This booster contains the same electronic circuitry as FCC ID: PWO 460052, except for the enclosure.

All the test data from FCC ID: PWO460052 was used for this booster except Radiated Spurious Emissions.

New data was recorded for Radiated Spurious Emissions.

The following frequency bands and emission types are utilized.

Frequency Band (MHz)					
Band Designator	B12	B13	B5	B25	B4
Uplink	698 - 716	776 – 787 (IC, 777 – 787)	824 - 849	1850 - 1915	1710 – 1755
Downlink	728 - 746	746 – 757 (IC, 746 – 756)	869 - 894	1930 - 1995	2110 - 2155
Modulation Type	LTE		GSM, CDMA, EDGE, HSPA, EVDO, LTE		CDMA, HSPA, LTE, EDGE, EVDO

Emission Designators					
CDMA	HSPA	LTE	EVDO	EDGE	GSM
F9W	F9W	G7D	F9W	G7W	GXW

The modulation types and emission designators listed in the tables represent the modulations that the cell phone providers use for each frequency band. GSM, CDMA, and WCDMA represent all the modulation types (phase and amplitude or a combination thereof) utilized within the industry. EDGE, HSPA, LTE etc. are all protocols or multiplexing techniques using the base modulations.

The EUT is an In-building signal booster with 4 server ports and 3 donor ports.

The server ports are referred to as Server Port 1 thru Server Port 4 or S1 thru S4 throughout the test report. The server ports are the uplink input and downlink output ports.

The donor ports are referred to as Dedicated Donor Ports 1 thru 3, or Dedicated D1 thru D3, and Common D1. The Donor ports are the uplink output and downlink input ports.

The 3 donor ports can be switched between dedicated and common ports.

When the internal switch is set to position 1 the donor port configuration is dedicated and the Cellular Bands are routed thru the dedicated ports per Table 1.

When the switch is set to position 2 the donor port configuration is Common and the Cellular Bands are routed thru the Common port per Table 1.

Note: For the common port, the signal path for dedicated and common ports is the same for Band 4 and Band 25, so the tests for those 2 bands are only documented 1 time.

Table 1 – Donor port assignment

Band	Switch position 1 – Dedicated ports	Switch position 2 – Common ports
12	Donor port 3 (D3)	Donor Port 1 (D1)
13	Donor port 3 (D3)	Donor Port 1 (D1)
5	Donor Port 2 (D2)	Donor Port 1 (D1)
4	Donor Port 1 (D1)	Donor Port 1 (D1)
25	Donor Port 1 (D1)	Donor Port 1 (D1)

The following figure shows the server and donor port configuration.

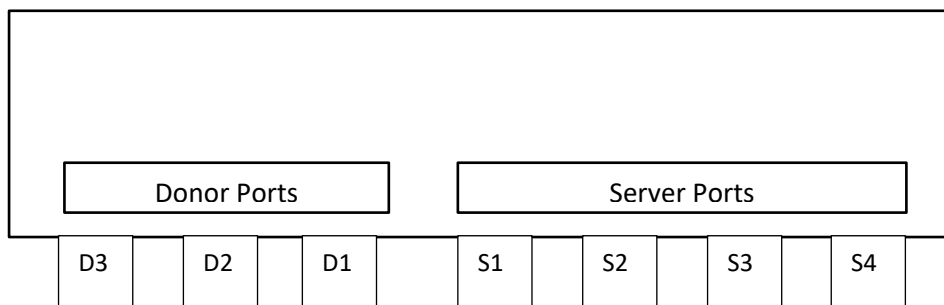

For all tests, the unused server and donor ports (any port not being tested) was terminated with 50 ohm termination.

This device has an internal cellular modem that is used for remote diagnostics and can only transmit on the uplink path. It can transmit on any uplink band.

This device contains FCC ID:N7NHL7588

Test Guidance was used from KDB 935210 D03 Signal Booster Measurements v04r03, KDB Inquiry 782203 (test guidance for common and dedicated ports) and KDB Inquiry 882937 (test guidance for additional tests with internal cellular modem).

KDB 935210 D03 Signal Booster Measurements v04r03 includes additional tests in section 7.15 for multiple server port configurations.

The additional tests in KDB 935210 D03 section 7.15 are:

1. For all RF paths:
 - 1) 7.1 Authorized frequency band verification test
 - 2) 7.11.2 Oscillation testing procedures; steps a) through r)
 - 3) 7.11.3 Oscillation testing procedures; steps a) through h)
2. For all downlink paths:
 - i) 7.2 Maximum power measurement test procedure
 - ii) 7.6 Conducted spurious emissions test procedure
3. Per KDB 935210 D03 section 7.15 b)2)ii) applies to this booster. The server port antennas will be used to provide coverage to different areas within a building and will be installed with a minimum of 10 meters separation between server port antennas.

KDB inquiry 882937 provides test guidance for consumer boosters with internal cellular modems used for internal diagnostics and remote monitoring capabilities.

The following tests are required per KDB inquiry 882937:

1. Conducted output power with the modem on but not transmitting
2. Conducted spurious, with Modem transmitting and another in-band signal at the input
3. Radiated spurious into a load with Modem transmitting and another in-band signal at the input
4. Noise power with modem on but not transmitting
5. 3 tone intermodulation test.

KDB Inquiry 782203 provides test guidance for consumer boosters with multiple donor ports.

The following tests are required per KDB inquiry 782203:

1. Full port testing for each signal path.
2. Isolation between donor ports for common port and dedicated port operation.

Note: For the common port, the signal path for dedicated and common ports is the same for Band 4 and Band 25, so the tests for those 2 bands are only documented 1 time.

Refer to the individual test sections for additional details for each test.

EUT Operation during Tests

The EUT was in a normal operating condition.

The EUT does not have any external attenuation controls.

The EUT is powered by 120 VAC 60 Hz.

Test Result Summary

Specification		Test Name	Pass, Fail, N/A	Comments
FCC	ISED			
20.21(e)(3)	RSS-131_3.5(a)	Authorized Frequency Band	Pass	
20.21(e)(8)(i)(B) 20.21(e)(8)(i)(C) 20.21(e)(8)(i)(D)	RSS-131_5.1.1.2 RSS-131_5.1.3.3	Maximum Power and Gain	Pass	
20.21(e)(8)(i)(F)	RSS-131_5.1.3.5	Intermodulation	Pass	
20.21(e)(8)(i)(E)	RSS-131_5.1.3.4	Out-of-Band Emissions	Pass	
2.1051 22.917(a) 24.238(a) 27.53(c) 27.53(f) 27.53(g) 27.53(h)	RSS-130_4.7.1 RSS-130_4.7.2 RSS-132_5.5 RSS-133_6.5.1 RSS-139_6.6	Conducted Spurious Emissions	Pass	
20.21(e)(8)(i)(A)	RSS-131_5.1.3.1	Noise Limits	Pass	
20.21(e)(8)(i)(I)	RSS-131_5.1.3.7	Uplink Inactivity	Pass	
20.21(e)(8)(i)(C)(1) 20.21(e)(8)(i)(H) 20.21(e)(8)(i)(C)(2)(i) (Fixed)	RSS-131_5.1.3.2	Variable Gain	Pass	
2.1049	RSS-GEN_6.7	Occupied Bandwidth	Pass	
20.21(e)(8)(ii)(A)	RSS-131_5.1.1.1	Anti - Oscillation	Pass	
2.1053	RSS-GEN_6.13	Radiated Spurious	Pass	
KDB Inquiry:883937	N/A	Conducted Spurious w/ modem transmitting	Pass	Additional test required for internal cellular modem
KDB Inquiry:883937	N/A	3 tone Intermodulation test w/ modem transmitting	Pass	Additional test required for internal cellular modem
KDB Inquiry:883937	N/A	Radiated Spurious w/ modem transmitting	Pass	Additional test required for internal cellular modem
KDB Inquiry:782203	N/A	Isolation	Pass	Additional test required multiple donor ports

Authorized Frequency Band

Engineer: Greg Corbin

Test Date: 4/30/2019

Test Procedure

The EUT was connected to a spectrum analyzer through an attenuator with the losses being input into the spectrum analyzer as a combination of reference level offset and correction factor as needed to ensure accurate readings. A signal generator was utilized to produce a CW input signal tuned to the center channel of the operational band. The RF input level was increased to a point just prior to the AGC being in control of the power. The Signal generator was set to sweep across 2X the operational band of the EUT while the spectrum analyzer was set to MAX HOLD. Two markers were placed at the edges of the operational band and a third marker was placed at the highest point within the band no closer than 2.5 MHz from the band edge.

All signal paths were tested as summarized in the table below.

Test Setup

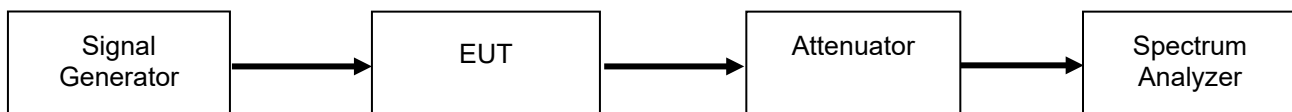

Signal Paths measured for Authorized Frequency Band

Authorized Frequency Band					Authorized Frequency Band		
Dedicated Ports					Common Ports		
U/L					U/L		
B12	B13	B5	B4	B25	B12	B13	B5
S1 to D3	S1 to D3	S1 to D2	S1 to D1	S1 to D1	S1 to D1	S1 to D1	S1 to D1
S2 to D3	S2 to D3	S2 to D2	S2 to D1	S2 to D1	S2 to D1	S2 to D1	S2 to D1
S3 to D3	S3 to D3	S3 to D2	S3 to D1	S3 to D1	S3 to D1	S3 to D1	S3 to D1
S4 to D3	S4 to D3	S4 to D2	S4 to D1	S4 to D1	S4 to D1	S4 to D1	S4 to D1
D/L					D/L		
B12	B13	B5	B4	B25	B12	B13	B5
D3 to S1	D3 to S1	D2 to S1	D1 to S1	D1 to S1	D1 to S1	D1 to S1	D1 to S1
D3 to S2	D3 to S2	D2 to S2	D1 to S2	D1 to S2	D1 to S2	D1 to S2	D1 to S2
D3 to S3	D3 to S3	D2 to S3	D1 to S3	D1 to S3	D1 to S3	D1 to S3	D1 to S3
D3 to S4	D3 to S4	D2 to S4	D1 to S4	D1 to S4	D1 to S4	D1 to S4	D1 to S4

Annex A Authorized Frequency Band

Refer to Annex A for Authorized Frequency Band plots.

Maximum Power and Gain

Engineer: Greg Corbin

Test Date: 5/6/2019

Test Procedure

The EUT was connected to a spectrum analyzer through an attenuator with the losses being input into the spectrum analyzer as a combination of reference level offset and correction factor as needed to ensure accurate readings. The spectrum analyzer and signal generator were tuned to the frequency with the highest power level in the band, as determined by the Authorized Frequency Band test. The RF input level was increased to a point just prior to the AGC being in control of the power for both pulsed single time slot GSM modulation and 4.1 MHz AWGN modulation. The maximum power was measured and verified to meet the minimum and maximum levels allowed, with the maximum gain being computed from these values. The uplink and downlink gain under each condition were verified to be within 9 dB of each other.

The input level was incremented in 2 dB steps up to the maximum input level for the EUT. The output power was recorded at the maximum input level. If the EUT shutdown before the maximum input level was reached, the input level was reduced to 1 dB before the EUT shutdown and the input and output levels were recorded.

For Fixed installations the following formula was used for calculating the gain limits.

$$\text{Gain Limit (dB)} = 6.5 \text{ dB} + 20\text{Log}(F_{\text{MHz}})$$

F_{MHz} is the uplink mid-band frequency with the downlink gain limit being equivalent to the paired Uplink band gain limit.

$$\text{Antenna Gain (dBi)} = \text{maximum antenna gain} + \text{the minimum cable loss}$$

Test Setup

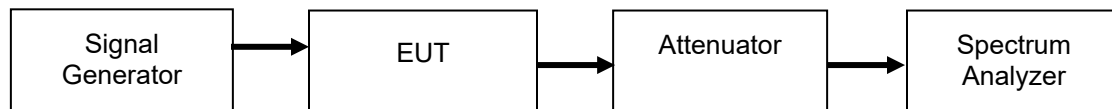

Signal Paths measured for Output Power and Gain

Output Power and Gain					Output Power and Gain		
Dedicated Ports					Common Ports		
U/L					U/L		
B12	B13	B5	B4	B25	B12	B13	B5
S1 to D3	S1 to D3	S1 to D2	S1 to D1	S1 to D1	S1 to D1	S1 to D1	S1 to D1
S2 to D3	S2 to D3	S2 to D2	S2 to D1	S2 to D1	S2 to D1	S2 to D1	S2 to D1
S3 to D3	S3 to D3	S3 to D2	S3 to D1	S3 to D1	S3 to D1	S3 to D1	S3 to D1
S4 to D3	S4 to D3	S4 to D2	S4 to D1	S4 to D1	S4 to D1	S4 to D1	S4 to D1
D/L					D/L		
B12	B13	B5	B4	B25	B12	B13	B5
D3 to S1	D3 to S1	D2 to S1	D1 to S1	D1 to S1	D1 to S1	D1 to S1	D1 to S1
D3 to S2	D3 to S2	D2 to S2	D1 to S2	D1 to S2	D1 to S2	D1 to S2	D1 to S2
D3 to S3	D3 to S3	D2 to S3	D1 to S3	D1 to S3	D1 to S3	D1 to S3	D1 to S3
D3 to S4	D3 to S4	D2 to S4	D1 to S4	D1 to S4	D1 to S4	D1 to S4	D1 to S4

Uplink Power Test Results
Server Port 1 to Dedicated Donor Port

Frequency Band (MHz)	Input Level (dBm)	Output Power (dBm)	Antenna Gain (dBi)	EIRP (dBm)	Lower Limit (dBm)	Upper Limit (dBm)	Result
698 - 716 MHz Pulsed GSM	-32.2	23.8	3.576	27.38	17	30	Pass
698 - 716 MHz AWGN	-32.1	22.8	3.576	26.38	17	30	Pass
776 - 787 MHz Pulsed GSM	-32.7	23.5	3.21	26.71	17	30	Pass
776 - 787 MHz AWGN	-32.2	23.0	3.21	26.21	17	30	Pass
824 - 849 MHz Pulsed GSM	-33.1	24.3	3.012	27.31	17	30	Pass
824 - 849 MHz AWGN	-32.0	24.4	3.012	27.41	17	30	Pass
1710 - 1755 MHz Pulsed GSM	-39.2	24.0	2.048	26.05	17	30	Pass
1710 - 1755 MHz AWGN	-39.8	22.6	2.048	24.65	17	30	Pass
1850 - 1915 MHz Pulsed GSM	-39.5	25.0	1.918	26.92	17	30	Pass
1850 - 1915 MHz AWGN	-38.2	25.4	1.918	27.32	17	30	Pass

Downlink Power Test Results
Server Port 1 to Dedicated Donor Port

Frequency Band (MHz)	Input Level (dBm)	Output Power (dBm)	Antenna Gain (dBi)	EIRP (dBm)	Upper Limit (dBm)	Result
728 - 746 MHz Pulsed GSM	-44.7	16.0	-2.43	13.57	17	Pass
728 - 746 MHz AWGN	-44.6	16.2	-2.43	13.77	17	Pass
746 - 757 MHz Pulsed GSM	-44.8	16.5	-1.69	14.81	17	Pass
746 - 757 MHz AWGN	-45.0	16.0	-1.69	14.31	17	Pass
869 - 894 MHz Pulsed GSM	-45.4	16.7	-3.09	13.61	17	Pass
869 - 894 MHz AWGN	-45.2	16.6	-3.09	13.51	17	Pass
1930 - 1995 MHz Pulsed GSM	-51.9	16.0	-1.29	14.71	17	Pass
1930 - 1995 MHz AWGN	-52.5	15.9	-1.29	14.61	17	Pass
2110 - 2155 MHz Pulsed GSM	-50.5	16.5	-0.33	16.17	17	Pass
2110 - 2155 MHz AWGN	-51.5	16.4	-0.33	16.07	17	Pass

**Uplink and Downlink Gain Test Results
Server Port 1 to Dedicated Donor Port**

Modulation	Uplink Frequency (MHz)	Downlink Frequency (MHz)	Uplink Gain (dB)	Uplink Limit (dB)	Downlink Gain (dB)	Downlink Limit (dB)	Delta (dB)	Limit (dB)	Margin (dB)
Pulsed GSM	710.55	745.385	56.0	63.5	60.7	63.5	4.7	9	-4.3
AWGN	710.55	745.385	54.9	63.5	60.8	63.5	5.9	9	-3.1
Pulsed GSM	778.85	746.335	56.2	64.4	61.3	64.4	5.1	9	-3.9
AWGN	778.85	746.335	55.2	64.4	61.0	64.4	5.8	9	-3.2
Pulsed GSM	835.3	877.9	57.4	64.9	62.1	64.9	4.7	9	-4.3
AWGN	835.3	877.9	56.4	64.9	61.8	64.9	5.4	9	-3.6
Pulsed GSM	1730.91	2149.15	63.2	71	67.0	71	3.8	9	-5.2
AWGN	1730.91	2149.15	62.4	71	67.9	71	5.5	9	-3.5
Pulsed GSM	1863.9	1946	64.5	72	67.9	72	3.4	9	-5.6
AWGN	1863.9	1946	63.6	72	68.4	72	4.8	9	-4.2

**Uplink Output Power at Maximum Input Power Test
Server Port 1 to Dedicated Donor Port**

Frequency Band (MHz)	Maximum Input Level (dBm)	Output Power at Maximum Input Power (dBm)	Antenna Gain (dBi)	EIRP (dBm)	Lower Limit (dBm)	Upper Limit (dBm)	Result
698 - 716 MHz Pulsed GSM	0.0	23.3	3.576	26.88	17	30	Pass
698 - 716 MHz AWGN	0.0	22.5	3.576	26.08	17	30	Pass
776 - 787 MHz Pulsed GSM	0.0	22.9	3.21	26.11	17	30	Pass
776 - 787 MHz AWGN	0.0	23.0	3.21	26.21	17	30	Pass
824 - 849 MHz Pulsed GSM	0.0	23.6	3.012	26.61	17	30	Pass
824 - 849 MHz AWGN	0.0	24.2	3.012	27.21	17	30	Pass
1710 - 1755 MHz Pulsed GSM	0.0	23.8	2.048	25.85	17	30	Pass
1710 - 1755 MHz AWGN	0.0	24.5	2.048	26.55	17	30	Pass
1850 - 1915 MHz Pulsed GSM	0.0	24.7	1.918	26.62	17	30	Pass
1850 - 1915 MHz AWGN	0.0	25.4	1.918	27.32	17	30	Pass

**Downlink Output Power at Maximum Input Power Test
 Server Port 1 to Dedicated Donor Port**

Frequency Band (MHz)	Maximum Input Level (dBm)	Output Power at Maximum Input Power (dBm)	Antenna Gain (dBi)	EIRP (dBm)	Upper Limit (dBm)	Result
728 - 746 MHz Pulsed GSM	-20.0	16.0	-2.43	13.57	17	Pass
728 - 746 MHz AWGN	-20.0	16.2	-2.43	13.77	17	Pass
746 - 757 MHz Pulsed GSM	-20.0	15.8	-1.69	14.11	17	Pass
746 - 757 MHz AWGN	-20.0	15.9	-1.69	14.21	17	Pass
869 - 894 MHz Pulsed GSM	-20.0	16.2	-3.09	13.11	17	Pass
869 - 894 MHz AWGN	-20.0	16.1	-3.09	13.01	17	Pass
1930 - 1995 MHz Pulsed GSM	-20.0	15.7	-1.29	14.41	17	Pass
1930 - 1995 MHz AWGN	-20.0	15.6	-1.29	14.31	17	Pass
2110 - 2155 MHz Pulsed GSM	-20.0	16.1	-0.33	15.77	17	Pass
2110 - 2155 MHz AWGN	-20.0	16.3	-0.33	15.97	17	Pass

Uplink Power Test Results
Server Port 2 to Dedicated Donor Port

Frequency Band (MHz)	Input Level (dBm)	Output Power (dBm)	Antenna Gain (dBi)	EIRP (dBm)	Lower Limit (dBm)	Upper Limit (dBm)	Result
698 - 716 MHz Pulsed GSM	-32.4	23.9	3.576	27.48	17	30	Pass
698 - 716 MHz AWGN	-32.5	22.9	3.576	26.48	17	30	Pass
776 - 787 MHz Pulsed GSM	-34.2	23.5	3.21	26.71	17	30	Pass
776 - 787 MHz AWGN	-33.4	23.0	3.21	26.21	17	30	Pass
824 - 849 MHz Pulsed GSM	-32.9	24.4	3.012	27.41	17	30	Pass
824 - 849 MHz AWGN	-32.0	24.5	3.012	27.51	17	30	Pass
1710 - 1755 MHz Pulsed GSM	-39.9	23.4	2.048	25.45	17	30	Pass
1710 - 1755 MHz AWGN	-39.9	22.7	2.048	24.75	17	30	Pass
1850 - 1915 MHz Pulsed GSM	-40.0	24.9	1.918	26.82	17	30	Pass
1850 - 1915 MHz AWGN	-38.6	25.4	1.918	27.32	17	30	Pass

Downlink Power Test Results
Server Port 2 to Dedicated Donor Port

Frequency Band (MHz)	Input Level (dBm)	Output Power (dBm)	Antenna Gain (dBi)	EIRP (dBm)	Upper Limit (dBm)	Result
728 - 746 MHz Pulsed GSM	-44.5	16.6	-2.43	14.17	17	Pass
728 - 746 MHz AWGN	-44.6	16.8	-2.43	14.37	17	Pass
746 - 757 MHz Pulsed GSM	-45.7	16.4	-1.69	14.71	17	Pass
746 - 757 MHz AWGN	-45.0	16.5	-1.69	14.81	17	Pass
869 - 894 MHz Pulsed GSM	-44.5	16.9	-3.09	13.81	17	Pass
869 - 894 MHz AWGN	-45.1	16.7	-3.09	13.61	17	Pass
1930 - 1995 MHz Pulsed GSM	-51.9	16.8	-1.29	15.51	17	Pass
1930 - 1995 MHz AWGN	-52.5	16.6	-1.29	15.31	17	Pass
2110 - 2155 MHz Pulsed GSM	-50.6	16.6	-0.33	16.27	17	Pass
2110 - 2155 MHz AWGN	-51.3	16.6	-0.33	16.27	17	Pass

**Uplink and Downlink Gain Test Results
Server Port 2 to Dedicated Donor Port**

Modulation	Uplink Frequency (MHz)	Downlink Frequency (MHz)	Uplink Gain (dB)	Uplink Limit (dB)	Downlink Gain (dB)	Downlink Limit (dB)	Delta (dB)	Limit (dB)	Margin (dB)
Pulsed GSM	710.6	745.25	56.3	63.5	61.1	63.5	4.8	9	-4.2
AWGN	710.6	745.25	55.4	63.5	61.4	63.5	6	9	-3
Pulsed GSM	778.05	746.655	57.7	64.4	62.1	64.4	4.4	9	-4.6
AWGN	778.05	746.655	56.4	64.4	61.5	64.4	5.1	9	-3.9
Pulsed GSM	834.25	878.25	57.3	64.9	61.4	64.9	4.1	9	-4.9
AWGN	834.25	878.25	56.5	64.9	61.8	64.9	5.3	9	-3.7
Pulsed GSM	1731.35	2149.39	63.3	71	67.2	71	3.9	9	-5.1
AWGN	1731.35	2149.39	62.6	71	67.9	71	5.3	9	-3.7
Pulsed GSM	1867.05	1946	64.9	72	68.7	72	3.8	9	-5.2
AWGN	1867.05	1946	64.0	72	69.1	72	5.1	9	-3.9

**Uplink Output Power at Maximum Input Power Test
Server Port 2 to Dedicated Donor Port**

Frequency Band (MHz)	Maximum Input Level (dBm)	Output Power at Maximum Input Power (dBm)	Antenna Gain (dBi)	EIRP (dBm)	Lower Limit (dBm)	Upper Limit (dBm)	Result
698 - 716 MHz Pulsed GSM	0.0	23.9	3.576	27.48	17	30	Pass
698 - 716 MHz AWGN	0.0	22.7	3.576	26.28	17	30	Pass
776 - 787 MHz Pulsed GSM	0.0	22.8	3.21	26.01	17	30	Pass
776 - 787 MHz AWGN	0.0	22.1	3.21	25.31	17	30	Pass
824 - 849 MHz Pulsed GSM	0.0	23.9	3.012	26.91	17	30	Pass
824 - 849 MHz AWGN	0.0	24.5	3.012	27.51	17	30	Pass
1710 - 1755 MHz Pulsed GSM	0.0	22.8	2.048	24.85	17	30	Pass
1710 - 1755 MHz AWGN	0.0	22.4	2.048	24.45	17	30	Pass
1850 - 1915 MHz Pulsed GSM	0.0	24.2	1.918	26.12	17	30	Pass
1850 - 1915 MHz AWGN	0.0	25.1	1.918	27.02	17	30	Pass

**Downlink Output Power at Maximum Input Power Test
 Server Port 2 to Dedicated Donor Port**

Frequency Band (MHz)	Maximum Input Level (dBm)	Output Power at Maximum Input Power (dBm)	Antenna Gain (dBi)	EIRP (dBm)	Upper Limit (dBm)	Result
728 - 746 MHz Pulsed GSM	-20.0	16.2	-2.43	13.77	17	Pass
728 - 746 MHz AWGN	-20.0	16.8	-2.43	14.37	17	Pass
746 - 757 MHz Pulsed GSM	-20.0	16.2	-1.69	14.51	17	Pass
746 - 757 MHz AWGN	-20.0	16.5	-1.69	14.81	17	Pass
869 - 894 MHz Pulsed GSM	-20.0	16.5	-3.09	13.41	17	Pass
869 - 894 MHz AWGN	-20.0	16.2	-3.09	13.11	17	Pass
1930 - 1995 MHz Pulsed GSM	-20.0	16.5	-1.29	15.21	17	Pass
1930 - 1995 MHz AWGN	-20.0	16.2	-1.29	14.91	17	Pass
2110 - 2155 MHz Pulsed GSM	-20.0	16.1	-0.33	15.77	17	Pass
2110 - 2155 MHz AWGN	-20.0	16.2	-0.33	15.87	17	Pass

Uplink Power Test Results
Server Port 3 to Dedicated Donor Port

Frequency Band (MHz)	Input Level (dBm)	Output Power (dBm)	Antenna Gain (dBi)	EIRP (dBm)	Lower Limit (dBm)	Upper Limit (dBm)	Result
698 - 716 MHz Pulsed GSM	-32.3	23.6	3.576	27.18	17	30	Pass
698 - 716 MHz AWGN	-32.3	22.7	3.576	26.28	17	30	Pass
776 - 787 MHz Pulsed GSM	-33.7	23.5	3.21	26.71	17	30	Pass
776 - 787 MHz AWGN	-32.9	23.0	3.21	26.21	17	30	Pass
824 - 849 MHz Pulsed GSM	-33.2	24.5	3.012	27.51	17	30	Pass
824 - 849 MHz AWGN	-32.4	24.6	3.012	27.61	17	30	Pass
1710 - 1755 MHz Pulsed GSM	-40.8	23.3	2.048	25.35	17	30	Pass
1710 - 1755 MHz AWGN	-40.8	22.7	2.048	24.75	17	30	Pass
1850 - 1915 MHz Pulsed GSM	-40.2	24.8	1.918	26.72	17	30	Pass
1850 - 1915 MHz AWGN	-38.7	25.4	1.918	27.32	17	30	Pass

Downlink Power Test Results
Server Port 3 to Dedicated Donor Port

Frequency Band (MHz)	Input Level (dBm)	Output Power (dBm)	Antenna Gain (dBi)	EIRP (dBm)	Upper Limit (dBm)	Result
728 - 746 MHz Pulsed GSM	-44.8	16.6	-2.43	14.17	17	Pass
728 - 746 MHz AWGN	-44.9	16.8	-2.43	14.37	17	Pass
746 - 757 MHz Pulsed GSM	-45.7	16.5	-1.69	14.81	17	Pass
746 - 757 MHz AWGN	-45.0	16.7	-1.69	15.01	17	Pass
869 - 894 MHz Pulsed GSM	-44.6	16.8	-3.09	13.71	17	Pass
869 - 894 MHz AWGN	-45.0	16.8	-3.09	13.71	17	Pass
1930 - 1995 MHz Pulsed GSM	-51.8	16.0	-1.29	14.71	17	Pass
1930 - 1995 MHz AWGN	-52.5	15.8	-1.29	14.51	17	Pass
2110 - 2155 MHz Pulsed GSM	-50.6	16.1	-0.33	15.77	17	Pass
2110 - 2155 MHz AWGN	-51.4	16.0	-0.33	15.67	17	Pass

**Uplink and Downlink Gain Test Results
 Server Port 3 to Dedicated Donor Port**

Modulation	Uplink Frequency (MHz)	Downlink Frequency (MHz)	Uplink Gain (dB)	Uplink Limit (dB)	Downlink Gain (dB)	Downlink Limit (dB)	Delta (dB)	Limit (dB)	Margin (dB)
Pulsed GSM	710.15	745.43	55.9	63.5	61.4	63.5	5.5	9	-3.5
AWGN	710.15	745.43	55.0	63.5	61.7	63.5	6.7	9	-2.3
Pulsed GSM	777.95	746.7	57.2	64.4	62.2	64.4	5	9	-4
AWGN	777.95	746.7	55.9	64.4	61.7	64.4	5.8	9	-3.2
Pulsed GSM	834.14	878.2	57.7	64.9	61.4	64.9	3.7	9	-5.3
AWGN	834.14	878.2	57.0	64.9	61.8	64.9	4.8	9	-4.2
Pulsed GSM	1734.39	2149.45	64.1	71	66.7	71	2.6	9	-6.4
AWGN	1734.39	2149.45	63.5	71	67.4	71	3.9	9	-5.1
Pulsed GSM	1893.9	1946.3	65.0	72	67.8	72	2.8	9	-6.2
AWGN	1893.9	1946.3	64.1	72	68.3	72	4.2	9	-4.8

**Uplink Output Power at Maximum Input Power Test
 Server Port 3 to Dedicated Donor Port**

Frequency Band (MHz)	Maximum Input Level (dBm)	Output Power at Maximum Input Power (dBm)	Antenna Gain (dBi)	EIRP (dBm)	Lower Limit (dBm)	Upper Limit (dBm)	Result
698 - 716 MHz Pulsed GSM	0.0	23.1	3.576	26.68	17	30	Pass
698 - 716 MHz AWGN	0.0	22.7	3.576	26.28	17	30	Pass
776 - 787 MHz Pulsed GSM	0.0	22.9	3.21	26.11	17	30	Pass
776 - 787 MHz AWGN	0.0	22.6	3.21	25.81	17	30	Pass
824 - 849 MHz Pulsed GSM	0.0	24.0	3.012	27.01	17	30	Pass
824 - 849 MHz AWGN	0.0	24.5	3.012	27.51	17	30	Pass
1710 - 1755 MHz Pulsed GSM	0.0	22.6	2.048	24.65	17	30	Pass
1710 - 1755 MHz AWGN	0.0	22.4	2.048	24.45	17	30	Pass
1850 - 1915 MHz Pulsed GSM	0.0	24.2	1.918	26.12	17	30	Pass
1850 - 1915 MHz AWGN	0.0	25.1	1.918	27.02	17	30	Pass

**Downlink Output Power at Maximum Input Power Test
 Server Port 3 to Dedicated Donor Port**

Frequency Band (MHz)	Maximum Input Level (dBm)	Output Power at Maximum Input Power (dBm)	Antenna Gain (dBi)	EIRP (dBm)	Upper Limit (dBm)	Result
728 - 746 MHz Pulsed GSM	-20	16.2	-2.43	13.77	17	Pass
728 - 746 MHz AWGN	-20	16.8	-2.43	14.37	17	Pass
746 - 757 MHz Pulsed GSM	-20	16.3	-1.69	14.61	17	Pass
746 - 757 MHz AWGN	-20	16.7	-1.69	15.01	17	Pass
869 - 894 MHz Pulsed GSM	-20	16.4	-3.09	13.31	17	Pass
869 - 894 MHz AWGN	-20	16.4	-3.09	13.31	17	Pass
1930 - 1995 MHz Pulsed GSM	-20	15.6	-1.29	14.31	17	Pass
1930 - 1995 MHz AWGN	-20	15.5	-1.29	14.21	17	Pass
2110 - 2155 MHz Pulsed GSM	-20	15.7	-0.33	15.37	17	Pass
2110 - 2155 MHz AWGN	-20	15.8	-0.33	15.47	17	Pass

Uplink Power Test Results
Server Port 4 to Dedicated Donor Port

Frequency Band (MHz)	Input Level (dBm)	Output Power (dBm)	Antenna Gain (dBi)	EIRP (dBm)	Lower Limit (dBm)	Upper Limit (dBm)	Result
698 - 716 MHz Pulsed GSM	-32.0	23.6	3.576	27.18	17	30	Pass
698 - 716 MHz AWGN	-32.0	22.5	3.576	26.08	17	30	Pass
776 - 787 MHz Pulsed GSM	-33.0	23.5	3.21	26.71	17	30	Pass
776 - 787 MHz AWGN	-32.4	23.1	3.21	26.31	17	30	Pass
824 - 849 MHz Pulsed GSM	-32.8	24.4	3.012	27.41	17	30	Pass
824 - 849 MHz AWGN	-31.9	24.5	3.012	27.51	17	30	Pass
1710 - 1755 MHz Pulsed GSM	-39.7	23.5	2.048	25.55	17	30	Pass
1710 - 1755 MHz AWGN	-39.6	22.8	2.048	24.85	17	30	Pass
1850 - 1915 MHz Pulsed GSM	-39.9	25.0	1.918	26.92	17	30	Pass
1850 - 1915 MHz AWGN	-38.5	25.5	1.918	27.42	17	30	Pass

Downlink Power Test Results
Server Port 4 to Dedicated Donor Port

Frequency Band (MHz)	Input Level (dBm)	Output Power (dBm)	Antenna Gain (dBi)	EIRP (dBm)	Upper Limit (dBm)	Result
728 - 746 MHz Pulsed GSM	-44.7	16.4	-2.43	13.97	17	Pass
728 - 746 MHz AWGN	-44.6	16.5	-2.43	14.07	17	Pass
746 - 757 MHz Pulsed GSM	-45.7	16.2	-1.69	14.51	17	Pass
746 - 757 MHz AWGN	-45.0	16.4	-1.69	14.71	17	Pass
869 - 894 MHz Pulsed GSM	-44.6	16.5	-3.09	13.41	17	Pass
869 - 894 MHz AWGN	-45.2	16.3	-3.09	13.21	17	Pass
1930 - 1995 MHz Pulsed GSM	-51.8	14.8	-1.29	13.51	17	Pass
1930 - 1995 MHz AWGN	-52.5	14.6	-1.29	13.31	17	Pass
2110 - 2155 MHz Pulsed GSM	-50.6	15.0	-0.33	14.67	17	Pass
2110 - 2155 MHz AWGN	-51.4	14.9	-0.33	14.57	17	Pass

**Uplink and Downlink Gain Test Results
Server Port 4 to Dedicated Donor Port**

Modulation	Uplink Frequency (MHz)	Downlink Frequency (MHz)	Uplink Gain (dB)	Uplink Limit (dB)	Downlink Gain (dB)	Downlink Limit (dB)	Delta (dB)	Limit (dB)	Margin (dB)
Pulsed GSM	710.55	745.43	55.6	63.5	61.1	63.5	5.5	9	-3.5
AWGN	710.55	745.43	54.5	63.5	61.1	63.5	6.6	9	-2.4
Pulsed GSM	778.65	746.64	56.5	64.4	61.9	64.4	5.4	9	-3.6
AWGN	778.65	746.64	55.5	64.4	61.4	64.4	5.9	9	-3.1
Pulsed GSM	834.895	877.6	57.2	64.9	61.1	64.9	3.9	9	-5.1
AWGN	834.895	877.6	56.4	64.9	61.5	64.9	5.1	9	-3.9
Pulsed GSM	1730.85	2149.3	63.2	71	65.6	71	2.4	9	-6.6
AWGN	1730.85	2149.3	62.4	71	66.3	71	3.9	9	-5.1
Pulsed GSM	1894.05	1946	64.9	72	66.6	72	1.7	9	-7.3
AWGN	1894.05	1946	64.0	72	67.1	72	3.1	9	-5.9

**Uplink Output Power at Maximum Input Power Test
Server Port 4 to Dedicated Donor Port**

Frequency Band (MHz)	Maximum Input Level (dBm)	Output Power at Maximum Input Power (dBm)	Antenna Gain (dBi)	EIRP (dBm)	Lower Limit (dBm)	Upper Limit (dBm)	Result
698 - 716 MHz Pulsed GSM	0.0	22.7	3.576	26.28	17	30	Pass
698 - 716 MHz AWGN	0.0	22.5	3.576	26.08	17	30	Pass
776 - 787 MHz Pulsed GSM	0.0	22.8	3.21	26.01	17	30	Pass
776 - 787 MHz AWGN	0.0	23.0	3.21	26.21	17	30	Pass
824 - 849 MHz Pulsed GSM	0.0	23.5	3.012	26.51	17	30	Pass
824 - 849 MHz AWGN	0.0	24.0	3.012	27.01	17	30	Pass
1710 - 1755 MHz Pulsed GSM	0.0	22.8	2.048	24.85	17	30	Pass
1710 - 1755 MHz AWGN	0.0	22.5	2.048	24.55	17	30	Pass
1850 - 1915 MHz Pulsed GSM	0.0	24.3	1.918	26.22	17	30	Pass
1850 - 1915 MHz AWGN	0.0	25.2	1.918	27.12	17	30	Pass

**Downlink Output Power at Maximum Input Power Test
 Server Port 4 to Dedicated Donor Port**

Frequency Band (MHz)	Maximum Input Level (dBm)	Output Power at Maximum Input Power (dBm)	Antenna Gain (dBi)	EIRP (dBm)	Upper Limit (dBm)	Result
728 - 746 MHz Pulsed GSM	-20.0	16.0	-2.43	13.57	17	Pass
728 - 746 MHz AWGN	-20.0	16.6	-2.43	14.17	17	Pass
746 - 757 MHz Pulsed GSM	-20.0	15.5	-1.69	13.81	17	Pass
746 - 757 MHz AWGN	-20.0	15.9	-1.69	14.21	17	Pass
869 - 894 MHz Pulsed GSM	-20.0	15.9	-3.09	12.81	17	Pass
869 - 894 MHz AWGN	-20.0	16.3	-3.09	13.21	17	Pass
1930 - 1995 MHz Pulsed GSM	-20.0	14.0	-1.29	12.71	17	Pass
1930 - 1995 MHz AWGN	-20.0	14.4	-1.29	13.11	17	Pass
2110 - 2155 MHz Pulsed GSM	-20.0	15.0	-0.33	14.67	17	Pass
2110 - 2155 MHz AWGN	-20.0	14.9	-0.33	14.57	17	Pass

Uplink Power Test Results
Server Port 1 to Common Donor Port 1

Frequency Band (MHz)	Input Level (dBm)	Output Power (dBm)	Antenna Gain (dBi)	EIRP (dBm)	Lower Limit (dBm)	Upper Limit (dBm)	Result
698 - 716 MHz Pulsed GSM	-32.0	23.3	3.576	26.88	17	30	Pass
698 - 716 MHz AWGN	-32.7	21.3	3.576	24.88	17	30	Pass
776 - 787 MHz Pulsed GSM	-32.6	22.1	3.21	25.31	17	30	Pass
776 - 787 MHz AWGN	-32.7	21.7	3.21	24.91	17	30	Pass
824 - 849 MHz Pulsed GSM	-33.0	23.7	3.012	26.71	17	30	Pass
824 - 849 MHz AWGN	-32.6	23.7	3.012	26.71	17	30	Pass

Downlink Power Test Results
Server Port 1 to Common Donor Port 1

Frequency Band (MHz)	Input Level (dBm)	Output Power (dBm)	Antenna Gain (dBi)	EIRP (dBm)	Upper Limit (dBm)	Result
728 - 746 MHz Pulsed GSM	-43.1	16.1	-2.43	13.67	17	Pass
728 - 746 MHz AWGN	-43.6	16.2	-2.43	13.77	17	Pass
746 - 757 MHz Pulsed GSM	-43.8	15.9	-1.69	14.21	17	Pass
746 - 757 MHz AWGN	-44.0	15.9	-1.69	14.21	17	Pass
869 - 894 MHz Pulsed GSM	-44.5	16.7	-3.09	13.61	17	Pass
869 - 894 MHz AWGN	-44.9	16.6	-3.09	13.51	17	Pass

Uplink and Downlink Gain Test Results
Server Port 1 to Common Donor Port 1

Modulation	Uplink Frequency (MHz)	Downlink Frequency (MHz)	Uplink Gain (dB)	Uplink Limit (dB)	Downlink Gain (dB)	Downlink Limit (dB)	Delta (dB)	Limit (dB)	Margin (dB)
Pulsed GSM	710.345	745.46	55.3	63.5	59.2	63.5	3.9	9	-5.1
AWGN	710.345	745.46	54.0	63.5	59.8	63.5	5.8	9	-3.2
Pulsed GSM	778.9	746.43	54.7	64.4	59.7	64.4	5	9	-4
AWGN	778.9	746.43	54.4	64.4	59.9	64.4	5.5	9	-3.5
Pulsed GSM	835.3	878.095	56.7	64.9	61.2	64.9	4.5	9	-4.5
AWGN	835.3	878.095	56.3	64.9	61.5	64.9	5.2	9	-3.8

**Uplink Output Power at Maximum Input Power Test
Server Port 1 to Common Donor Port 1**

Frequency Band (MHz)	Maximum Input Level (dBm)	Output Power at Maximum Input Power (dBm)	Antenna Gain (dBi)	EIRP (dBm)	Lower Limit (dBm)	Upper Limit (dBm)	Result
698 - 716 MHz Pulsed GSM	0.0	21.8	3.576	25.38	17	30	Pass
698 - 716 MHz AWGN	0.0	21.1	3.576	24.68	17	30	Pass
776 - 787 MHz Pulsed GSM	0.0	21.5	3.21	24.71	17	30	Pass
776 - 787 MHz AWGN	0.0	21.7	3.21	24.91	17	30	Pass
824 - 849 MHz Pulsed GSM	0.0	23.7	3.012	26.71	17	30	Pass
824 - 849 MHz AWGN	0.0	23.6	3.012	26.61	17	30	Pass

**Downlink Output Power at Maximum Input Power Test
Server Port 1 to Common Donor Port 1**

Frequency Band (MHz)	Maximum Input Level (dBm)	Output Power at Maximum Input Power (dBm)	Antenna Gain (dBi)	EIRP (dBm)	Upper Limit (dBm)	Result
728 - 746 MHz Pulsed GSM	-20.0	15.7	-2.43	13.27	17	Pass
728 - 746 MHz AWGN	-20.0	16.1	-2.43	13.67	17	Pass
746 - 757 MHz Pulsed GSM	-20.0	15.8	-1.69	14.11	17	Pass
746 - 757 MHz AWGN	-20.0	15.9	-1.69	14.21	17	Pass
869 - 894 MHz Pulsed GSM	-20.0	16.8	-3.09	13.71	17	Pass
869 - 894 MHz AWGN	-20.0	16.2	-3.09	13.11	17	Pass

Uplink Power Test Results
Server Port 2 to Common Donor Port 1

Frequency Band (MHz)	Input Level (dBm)	Output Power (dBm)	Antenna Gain (dBi)	EIRP (dBm)	Lower Limit (dBm)	Upper Limit (dBm)	Result
698 - 716 MHz Pulsed GSM	-32.4	22.4	3.576	25.98	17	30	Pass
698 - 716 MHz AWGN	-33.1	21.5	3.576	25.08	17	30	Pass
776 - 787 MHz Pulsed GSM	-34.2	22.0	3.21	25.21	17	30	Pass
776 - 787 MHz AWGN	-34.0	21.5	3.21	24.71	17	30	Pass
824 - 849 MHz Pulsed GSM	-33.0	23.7	3.012	26.71	17	30	Pass
824 - 849 MHz AWGN	-32.7	24.0	3.012	27.01	17	30	Pass

Downlink Power Test Results
Server Port 2 to Common Donor Port 1

Frequency Band (MHz)	Input Level (dBm)	Output Power (dBm)	Antenna Gain (dBi)	EIRP (dBm)	Upper Limit (dBm)	Result
728 - 746 MHz Pulsed GSM	-43.1	16.7	-2.43	14.27	17	Pass
728 - 746 MHz AWGN	-43.6	16.7	-2.43	14.27	17	Pass
746 - 757 MHz Pulsed GSM	-43.9	16.6	-1.69	14.91	17	Pass
746 - 757 MHz AWGN	-44.1	16.4	-1.69	14.71	17	Pass
869 - 894 MHz Pulsed GSM	-44.5	16.9	-3.09	13.81	17	Pass
869 - 894 MHz AWGN	-44.9	16.7	-3.09	13.61	17	Pass

Uplink and Downlink Gain Test Results
Server Port 2 to Common Donor Port 1

Modulation	Uplink Frequency (MHz)	Downlink Frequency (MHz)	Uplink Gain (dB)	Uplink Limit (dB)	Downlink Gain (dB)	Downlink Limit (dB)	Delta (dB)	Limit (dB)	Margin (dB)
Pulsed GSM	709.85	745.445	54.8	63.5	59.8	63.5	5	9	-4
AWGN	709.85	745.445	54.6	63.5	60.3	63.5	5.7	9	-3.3
Pulsed GSM	777.95	746.64	56.2	64.4	60.5	64.4	4.3	9	-4.7
AWGN	777.95	746.64	55.5	64.4	60.5	64.4	5	9	-4
Pulsed GSM	833.455	877.945	56.7	64.9	61.4	64.9	4.7	9	-4.3
AWGN	833.455	877.945	56.7	64.9	61.6	64.9	4.9	9	-4.1

**Uplink Output Power at Maximum Input Power Test
Server Port 2 to Common Donor Port 1**

Frequency Band (MHz)	Maximum Input Level (dBm)	Output Power at Maximum Input Power (dBm)	Antenna Gain (dBi)	EIRP (dBm)	Lower Limit (dBm)	Upper Limit (dBm)	Result
698 - 716 MHz Pulsed GSM	0.0	22.4	3.576	25.98	17	30	Pass
698 - 716 MHz AWGN	0.0	21.4	3.576	24.98	17	30	Pass
776 - 787 MHz Pulsed GSM	0.0	21.3	3.21	24.51	17	30	Pass
776 - 787 MHz AWGN	0.0	21.3	3.21	24.51	17	30	Pass
824 - 849 MHz Pulsed GSM	0.0	23.2	3.012	26.21	17	30	Pass
824 - 849 MHz AWGN	0.0	23.9	3.012	26.91	17	30	Pass

**Downlink Output Power at Maximum Input Power Test
Server Port 2 to Common Donor Port 1**

Frequency Band (MHz)	Maximum Input Level (dBm)	Output Power at Maximum Input Power (dBm)	Antenna Gain (dBi)	EIRP (dBm)	Upper Limit (dBm)	Result
728 - 746 MHz Pulsed GSM	-20.0	16.7	-2.43	14.27	17	Pass
728 - 746 MHz AWGN	-20.0	16.4	-2.43	13.97	17	Pass
746 - 757 MHz Pulsed GSM	-20.0	16.0	-1.69	14.31	17	Pass
746 - 757 MHz AWGN	-20.0	16.6	-1.69	14.91	17	Pass
869 - 894 MHz Pulsed GSM	-20.0	-16.4	-3.09	-19.49	17	Pass
869 - 894 MHz AWGN	-20.0	16.4	-3.09	13.31	17	Pass

Uplink Power Test Results
Server Port 3 to Common Donor Port 1

Frequency Band (MHz)	Input Level (dBm)	Output Power (dBm)	Antenna Gain (dBi)	EIRP (dBm)	Lower Limit (dBm)	Upper Limit (dBm)	Result
698 - 716 MHz Pulsed GSM	-32.3	22.2	3.576	25.78	17	30	Pass
698 - 716 MHz AWGN	-32.8	21.5	3.576	25.08	17	30	Pass
776 - 787 MHz Pulsed GSM	-33.6	22.1	3.21	25.31	17	30	Pass
776 - 787 MHz AWGN	-33.5	21.7	3.21	24.91	17	30	Pass
824 - 849 MHz Pulsed GSM	-33.5	23.6	3.012	26.61	17	30	Pass
824 - 849 MHz AWGN	-33.2	23.9	3.012	26.91	17	30	Pass

Downlink Power Test Results
Server Port 3 to Common Donor Port 1

Frequency Band (MHz)	Input Level (dBm)	Output Power (dBm)	Antenna Gain (dBi)	EIRP (dBm)	Upper Limit (dBm)	Result
728 - 746 MHz Pulsed GSM	-43.0	16.8	-2.43	14.37	17	Pass
728 - 746 MHz AWGN	-43.5	16.9	-2.43	14.47	17	Pass
746 - 757 MHz Pulsed GSM	-43.8	16.7	-1.69	15.01	17	Pass
746 - 757 MHz AWGN	-43.9	16.7	-1.69	15.01	17	Pass
869 - 894 MHz Pulsed GSM	-44.5	16.8	-3.09	13.71	17	Pass
869 - 894 MHz AWGN	-44.8	16.8	-3.09	13.71	17	Pass

Uplink and Downlink Gain Test Results
Server Port 3 to Common Donor Port 1

Modulation	Uplink Frequency (MHz)	Downlink Frequency (MHz)	Uplink Gain (dB)	Uplink Limit (dB)	Downlink Gain (dB)	Downlink Limit (dB)	Delta (dB)	Limit (dB)	Margin (dB)
Pulsed GSM	709.9	745.39	54.5	63.5	59.8	63.5	5.3	9	-3.7
AWGN	709.9	745.39	54.3	63.5	60.4	63.5	6.1	9	-2.9
Pulsed GSM	777.9	746.355	55.7	64.4	60.5	64.4	4.8	9	-4.2
AWGN	777.9	746.355	55.2	64.4	60.6	64.4	5.4	9	-3.6
Pulsed GSM	832.225	878.005	57.1	64.9	61.3	64.9	4.2	9	-4.8
AWGN	832.225	878.005	57.1	64.9	61.6	64.9	4.5	9	-4.5

**Uplink Output Power at Maximum Input Power Test
Server Port 3 to Common Donor Port 1**

Frequency Band (MHz)	Maximum Input Level (dBm)	Output Power at Maximum Input Power (dBm)	Antenna Gain (dBi)	EIRP (dBm)	Lower Limit (dBm)	Upper Limit (dBm)	Result
698 - 716 MHz Pulsed GSM	0.0	21.6	3.576	25.18	17	30	Pass
698 - 716 MHz AWGN	0.0	21.4	3.576	24.98	17	30	Pass
776 - 787 MHz Pulsed GSM	0.0	21.5	3.21	24.71	17	30	Pass
776 - 787 MHz AWGN	0.0	21.3	3.21	24.51	17	30	Pass
824 - 849 MHz Pulsed GSM	0.0	23.2	3.012	26.21	17	30	Pass
824 - 849 MHz AWGN	0.0	23.8	3.012	26.81	17	30	Pass

**Downlink Output Power at Maximum Input Power Test
Server Port 3 to Common Donor Port 1**

Frequency Band (MHz)	Maximum Input Level (dBm)	Output Power at Maximum Input Power (dBm)	Antenna Gain (dBi)	EIRP (dBm)	Upper Limit (dBm)	Result
728 - 746 MHz Pulsed GSM	-20.0	16.4	-2.43	13.97	17	Pass
728 - 746 MHz AWGN	-20.0	16.6	-2.43	14.17	17	Pass
746 - 757 MHz Pulsed GSM	-20.0	16.1	-1.69	14.41	17	Pass
746 - 757 MHz AWGN	-20.0	16.3	-1.69	14.61	17	Pass
869 - 894 MHz Pulsed GSM	-20.0	16.8	-3.09	13.71	17	Pass
869 - 894 MHz AWGN	-20.0	16.4	-3.09	13.31	17	Pass

Uplink Power Test Results
Server Port 4 to Common Donor Port 1

Frequency Band (MHz)	Input Level (dBm)	Output Power (dBm)	Antenna Gain (dBi)	EIRP (dBm)	Lower Limit (dBm)	Upper Limit (dBm)	Result
698 - 716 MHz Pulsed GSM	-31.9	22.2	3.576	25.78	17	30	Pass
698 - 716 MHz AWGN	-32.6	21.1	3.576	24.68	17	30	Pass
776 - 787 MHz Pulsed GSM	-33.0	22.1	3.21	25.31	17	30	Pass
776 - 787 MHz AWGN	-33.1	21.7	3.21	24.91	17	30	Pass
824 - 849 MHz Pulsed GSM	-32.8	23.7	3.012	26.71	17	30	Pass
824 - 849 MHz AWGN	-32.5	23.9	3.012	26.91	17	30	Pass

Downlink Power Test Results
Server Port 4 to Common Donor Port 1

Frequency Band (MHz)	Input Level (dBm)	Output Power (dBm)	Antenna Gain (dBi)	EIRP (dBm)	Upper Limit (dBm)	Result
728 - 746 MHz Pulsed GSM	-43.1	16.5	-2.43	14.07	17	Pass
728 - 746 MHz AWGN	-43.7	16.5	-2.43	14.07	17	Pass
746 - 757 MHz Pulsed GSM	-44.0	16.3	-1.69	14.61	17	Pass
746 - 757 MHz AWGN	-44.0	16.4	-1.69	14.71	17	Pass
869 - 894 MHz Pulsed GSM	-44.5	16.6	-3.09	13.51	17	Pass
869 - 894 MHz AWGN	-44.9	16.3	-3.09	13.21	17	Pass

Uplink and Downlink Gain Test Results
Server Port 4 to Common Donor Port 1

Modulation	Uplink Frequency (MHz)	Downlink Frequency (MHz)	Uplink Gain (dB)	Uplink Limit (dB)	Downlink Gain (dB)	Downlink Limit (dB)	Delta (dB)	Limit (dB)	Margin (dB)
Pulsed GSM	710.45	745.445	54.1	63.5	59.6	63.5	5.5	9	-3.5
AWGN	710.45	745.445	53.7	63.5	60.2	63.5	6.5	9	-2.5
Pulsed GSM	778.6	746.66	55.1	64.4	60.3	64.4	5.2	9	-3.8
AWGN	778.6	746.66	54.8	64.4	60.4	64.4	5.6	9	-3.4
Pulsed GSM	834.85	877.75	56.5	64.9	61.1	64.9	4.6	9	-4.4
AWGN	834.85	877.75	56.4	64.9	61.2	64.9	4.8	9	-4.2

**Uplink Output Power at Maximum Input Power Test
Server Port 4 to Common Donor Port 1**

Frequency Band (MHz)	Maximum Input Level (dBm)	Output Power at Maximum Input Power (dBm)	Antenna Gain (dBi)	EIRP (dBm)	Lower Limit (dBm)	Upper Limit (dBm)	Result
698 - 716 MHz Pulsed GSM	0.0	21.3	3.576	24.88	17	30	Pass
698 - 716 MHz AWGN	0.0	20.9	3.576	24.48	17	30	Pass
776 - 787 MHz Pulsed GSM	0.0	21.4	3.21	24.61	17	30	Pass
776 - 787 MHz AWGN	0.0	21.5	3.21	24.71	17	30	Pass
824 - 849 MHz Pulsed GSM	0.0	22.9	3.012	25.91	17	30	Pass
824 - 849 MHz AWGN	0.0	23.2	3.012	26.21	17	30	Pass

**Downlink Output Power at Maximum Input Power Test
Server Port 4 to Common Donor Port 1**

Frequency Band (MHz)	Maximum Input Level (dBm)	Output Power at Maximum Input Power (dBm)	Antenna Gain (dBi)	EIRP (dBm)	Upper Limit (dBm)	Result
728 - 746 MHz Pulsed GSM	-20.0	16.5	-2.43	14.07	17	Pass
728 - 746 MHz AWGN	-20.0	16.5	-2.43	14.07	17	Pass
746 - 757 MHz Pulsed GSM	-20.0	15.6	-1.69	13.91	17	Pass
746 - 757 MHz AWGN	-20.0	16.3	-1.69	14.61	17	Pass
869 - 894 MHz Pulsed GSM	-20.0	16.1	-3.09	13.01	17	Pass
869 - 894 MHz AWGN	-20.0	16.0	-3.09	12.91	17	Pass

Intermodulation

Engineer: Greg Corbin

Test Date: 5/6/2019

Test Procedure

The EUT was connected to a spectrum analyzer through an attenuator. Two signal generators were utilized to produce two CW signals 600 kHz apart and centered at the peak of the operational band. Attenuator and cable insertion loss correction factors were input to either the signal generator or the spectrum analyzer as required to ensure that accurate measurements were recorded. The input power was set at the maximum allowable power and the RMS intermodulation products were measured to ensure they were less than -19 dBm in a 3 kHz RBW. The uplink and downlink intermodulation products were plotted, with the levels being listed in the summary tables.

The input power was increased in 2 dB increments to 10 dB above the AGC threshold and to verify the intermod products remain below the limit. During this test, the input power was not increased past the maximum allowed.

The Intermodulation level was recorded

Intermodulation_ Dedicated Ports

For D/L Intermodulation to dedicated ports, Server port 2 was selected due to Server port 2 has the shortest path to the internal combiner, which should be worst case.

Downlink intermodulation data was recorded from dedicated donor ports to server port 2 and server port 4.

Server port 1 and server port 3 utilize the same path as server port 2 and were not tested.

Intermodulation_ Common Ports

For the Uplink, Measured B12, B13, B5 from server ports 1,2,3,4 to Donor Port 1

For the Downlink, Measured B12, B13, B5 from Donor port 1 to Server ports 1,2,3,4

Donor port 1 (B4 and B25) was already measured when testing the dedicated port paths.

Test Setup

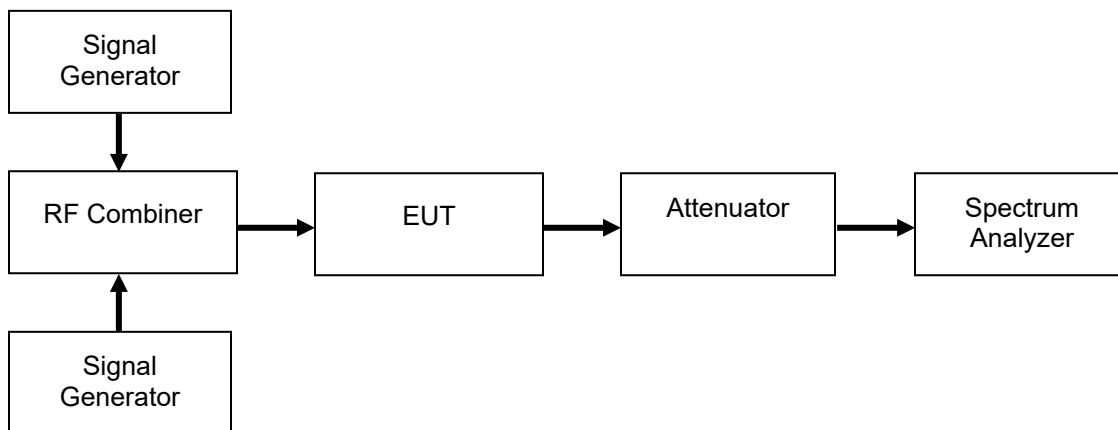

Signal Paths measured for Intermodulation

Intermodulation					Intermodulation		
Dedicated Ports					Common Ports		
U/L					U/L		
B12	B13	B5	B4	B25	B12	B13	B5
S1 to D3	S1 to D3	S1 to D2	S1 to D1	S1 to D1	S1 to D1	S1 to D1	S1 to D1
S2 to D3	S2 to D3	S2 to D2	S2 to D1	S2 to D1	S2 to D1	S2 to D1	S2 to D1
S3 to D3	S3 to D3	S3 to D2	S3 to D1	S3 to D1	S3 to D1	S3 to D1	S3 to D1
S4 to D3	S4 to D3	S4 to D2	S4 to D1	S4 to D1	S4 to D1	S4 to D1	S4 to D1
D/L					D/L		
B12	B13	B5	B4	B25	B12	B13	B5
D3 to S2	D3 to S2	D2 to S2	D1 to S2	D1 to S2	D1 to S1	D1 to S1	D1 to S1
D3 to S4	D3 to S4	D2 to S4	D1 to S4	D1 to S4	D1 to S2	D1 to S2	D1 to S2
					D1 to S3	D1 to S3	D1 to S3
					D1 to S4	D1 to S4	D1 to S4

Uplink Intermodulation Test Results Server Port 1 to Dedicated Donor Port

Frequency Band (MHz)	Intermodulation Level (dBm)	Limit (dBm)	Result	Intermod Level with Input Power @ AGC + 10 dB	Result (Pass / Fail)
698 - 716 MHz	-19.1	-19	Pass	-19.1	Pass
776 - 787 MHz	-19.28	-19	Pass	-21.67	Pass
824 - 849 MHz	-20.16	-19	Pass	-19.6	Pass
1710 - 1755 MHz	-19.5	-19	Pass	-19.67	Pass
1850 - 1915 MHz	-19.7	-19	Pass	-19.77	Pass

Uplink Intermodulation Test Results Server Port 2 to Dedicated Donor Port

Frequency Band (MHz)	Intermodulation Level (dBm)	Limit (dBm)	Result	Intermod Level with Input Power @ AGC + 10 dB	Result (Pass / Fail)
698 - 716 MHz	-19.2	-19	Pass	-19.5	Pass
776 - 787 MHz	-19.42	-19	Pass	-20.6	Pass
824 - 849 MHz	-19.63	-19	Pass	-20.6	Pass
1710 - 1755 MHz	-19.36	-19	Pass	-19.45	Pass
1850 - 1915 MHz	-19.52	-19	Pass	-20.1	Pass

**Uplink Intermodulation Test Results
 Server Port 3 to Dedicated Donor Port**

Frequency Band (MHz)	Intermodulation Level (dBm)	Limit (dBm)	Result	Intermod Level with Input Power @ AGC + 10 dB	Result (Pass / Fail)
698 - 716 MHz	-19.2	-19	Pass	-19.8	Pass
776 - 787 MHz	-19.52	-19	Pass	-19.2	Pass
824 - 849 MHz	-19.57	-19	Pass	-20.5	Pass
1710 - 1755 MHz	-19.34	-19	Pass	-20.97	Pass
1850 - 1915 MHz	-19.62	-19	Pass	-19.6	Pass

**Uplink Intermodulation Test Results
 Server Port 4 to Dedicated Donor Port**

Frequency Band (MHz)	Intermodulation Level (dBm)	Limit (dBm)	Result	Intermod Level with Input Power @ AGC + 10 dB	Result (Pass / Fail)
698 - 716 MHz	-19.2	-19	Pass	-19.4	Pass
776 - 787 MHz	-19.41	-19	Pass	-20.4	Pass
824 - 849 MHz	-19.64	-19	Pass	-21.8	Pass
1710 - 1755 MHz	-19.31	-19	Pass	-19.32	Pass
1850 - 1915 MHz	-19.76	-19	Pass	-20.04	Pass

**Downlink Intermodulation Test Results
 Dedicated Donor Port to Server Port 2**

Frequency Band (MHz)	Intermodulation Level (dBm)	Limit (dBm)	Result	Intermod Level with Input Power @ AGC + 10 dB	Result (Pass / Fail)
728 - 746 MHz	-25.73	-19	Pass	-26.5	Pass
746 - 757 MHz	-27	-19	Pass	-27.7	Pass
869 - 894 MHz	-37.9	-19	Pass	-37.2	Pass
1930 - 1995 MHz	-29.9	-19	Pass	-30.5	Pass
2110 - 2155 MHz	-28.3	-19	Pass	-29.5	Pass

**Downlink Intermodulation Test Results
Dedicated Donor Port to Server Port 4**

Frequency Band (MHz)	Intermodulation Level (dBm)	Limit (dBm)	Result	Intermod Level with Input Power @ AGC + 10 dB	Result (Pass / Fail)
728 - 746 MHz	-25.9	-19	Pass	-26.8	Pass
746 - 757 MHz	-26.9	-19	Pass	-27.6	Pass
869 - 894 MHz	-42.7	-19	Pass	-42.5	Pass
1930 - 1995 MHz	-37.3	-19	Pass	-37.2	Pass
2110 - 2155 MHz	-30.5	-19	Pass	-31.3	Pass

**Uplink Intermodulation Test Results
Server Port 1 to Common Donor Port 1**

Frequency Band (MHz)	Intermodulation Level (dBm)	Limit (dBm)	Result	Intermod Level with Input Power @ AGC + 10 dB	Result (Pass / Fail)
698 - 716 MHz	-20.8	-19	Pass	-21	Pass
776 - 787 MHz	-20.27	-19	Pass	-21.1	Pass
824 - 849 MHz	-20	-19	Pass	-21.2	Pass

**Uplink Intermodulation Test Results
Server Port 2 to Common Donor Port 1**

Frequency Band (MHz)	Intermodulation Level (dBm)	Limit (dBm)	Result	Intermod Level with Input Power @ AGC + 10 dB	Result (Pass / Fail)
698 - 716 MHz	-20.1	-19	Pass	-20.9	Pass
776 - 787 MHz	-20.17	-19	Pass	-19.7	Pass
824 - 849 MHz	-19.95	-19	Pass	-21.04	Pass

**Uplink Intermodulation Test Results
Server Port 3 to Common Donor Port 1**

Frequency Band (MHz)	Intermodulation Level (dBm)	Limit (dBm)	Result	Intermod Level with Input Power @ AGC + 10 dB	Result (Pass / Fail)
698 - 716 MHz	-20.8	-19	Pass	-21.64	Pass
776 - 787 MHz	-22.3	-19	Pass	21.8	Pass
824 - 849 MHz	-20.3	-19	Pass	-20.2	Pass

Uplink Intermodulation Test Results
Server Port 4 to Common Donor Port 1

Frequency Band (MHz)	Intermodulation Level (dBm)	Limit (dBm)	Result	Intermod Level with Input Power @ AGC + 10 dB	Result (Pass / Fail)
698 - 716 MHz	-20.98	-19	Pass	21.32	Pass
776 - 787 MHz	-20	-19	Pass	-21.2	Pass
824 - 849 MHz	-20.2	-19	Pass	-20.4	Pass

Downlink Intermodulation Test Results
Common Donor Port 1 to Server Port 1

Frequency Band (MHz)	Intermodulation Level (dBm)	Limit (dBm)	Result	Intermod Level with Input Power @ AGC + 10 dB	Result (Pass / Fail)
728 - 746 MHz	-25.7	-19	Pass	-26.5	Pass
746 - 757 MHz	-26.4	-19	Pass	-27.3	Pass
869 - 894 MHz	-38.3	-19	Pass	-38.3	Pass

Downlink Intermodulation Test Results
Common Donor Port 1 to Server Port 2

Frequency Band (MHz)	Intermodulation Level (dBm)	Limit (dBm)	Result	Intermod Level with Input Power @ AGC + 10 dB	Result (Pass / Fail)
728 - 746 MHz	-25.9	-19	Pass	-26.7	Pass
746 - 757 MHz	-26.8	-19	Pass	-27.6	Pass
869 - 894 MHz	-37.7	-19	Pass	-37.2	Pass

Downlink Intermodulation Test Results
Common Donor Port 1 to Server Port 3

Frequency Band (MHz)	Intermodulation Level (dBm)	Limit (dBm)	Result	Intermod Level with Input Power @ AGC + 10 dB	Result (Pass / Fail)
728 - 746 MHz	-25.2	-19	Pass	-26	Pass
746 - 757 MHz	-26.5	-19	Pass	-27.3	Pass
869 - 894 MHz	-36.8	-19	Pass	-36.8	Pass

**Downlink Intermodulation Test Results
 Common Donor Port 1 to Server Port 4**

Frequency Band (MHz)	Intermodulation Level (dBm)	Limit (dBm)	Result	Intermod Level with Input Power @ AGC + 10 dB	Result (Pass / Fail)
728 - 746 MHz	-25.9	-19	Pass	-26.7	Pass
746 - 757 MHz	-27	-19	Pass	-27.8	Pass
869 - 894 MHz	-41.5	-19	Pass	-41.1	Pass

Annex B Intermodulation

Refer to Annex B for Intermodulation Test plots

Out-of-Band Emissions

Engineer: Greg Corbin

Test Date: 5/25/2019

Test Procedure

The EUT was connected to a spectrum analyzer through an attenuator with the losses being input into the spectrum analyzer as a combination of reference level offset and correction factor in order to ensure accurate readings. A signal generator was utilized to produce the following signals: GSM, CDMA, and WCDMA. The signal generator was tuned to the lowest allowable upper and lower channel within the EUT operational band for each respective modulation type. The RF input level was increased to a point just prior to the AGC being in control of the power. For each modulation type the Out of Band Emissions were measured to ensure they met the limits.

The following formula was used for calculating the limits:

$$\text{Limit} = P1 - 6 - (43 + 10\text{Log}(P2)) = -19\text{dBm}$$

P1 = power in dBm

P2 = power in Watts

The input power was increased in 2 dB steps up to the maximum input power for the booster being tested. The OOBE was verified to stay below the OOBE Limit. This was recorded as Pass / Fail in the OOBE tables.

Per 935210 D03 v04r02 page 13, The test report shall include either a statement describing that the device complies at 10 dB above AGC or at the 5.5 power levels, or a table showing compliance at the additional input power(s) required.

The Booster is compliant to the maximum input levels per 935210 D03 v04r02 section 5.5.

Test Setup



Out of band Emissions was tested using the worst case determined by the signal path with the highest output power and gain.

Signal Paths measured for Out of Band Emissions

OOBE					OOBE		
Dedicated Ports					Common Ports		
U/L					U/L		
B12	B13	B5	B4	B25	B12	B13	B5
S2 to D3	S2 to D3	S3 to D2	S3 to D1	S4 to D1	S1 to D1	S3 to D1	S3 to D1
D/L					D/L		
B12	B13	B5	B4	B25	B12	B13	B5
D3 to S3	D3 to S3	D2 to S3	D1 to S2	D1 to S2	D1 to S3	D1 to S3	D1 to S2

GSM Uplink Test Results_ Dedicated Ports
 Refer to table on page 37 for signal paths utilized

Frequency Band (MHz)	Band Edge	Measured Level (dBm)	Limit (dBm)	Result	Oobe Below Limit at Max Input Power (Yes / No)
698 - 716	Lower	-24	-19	Pass	Y
698 - 716	Upper	-26.3	-19	Pass	Y
776 - 787	Lower	-24.4	-19	Pass	Y
776 - 787	Upper	-25.8	-19	Pass	Y
824 - 849	Lower	-29.7	-19	Pass	Y
824 - 849	Upper	-37.1	-19	Pass	Y
1710 - 1755	Lower	-32	-19	Pass	Y
1710 - 1755	Upper	-32.2	-19	Pass	Y
1850 - 1915	Lower	-27	-19	Pass	Y
1850 - 1915	Upper	-43.9	-19	Pass	Y

CDMA Uplink Test Results_ Dedicated Ports
 Refer to table on page 37 for signal paths utilized

Frequency Band (MHz)	Band Edge	Measured Level (dBm)	Limit (dBm)	Result	Oobe Below Limit at Max Input Power (Yes / No)
698 - 716	Lower	-45.7	-19	Pass	Y
698 - 716	Upper	-43.9	-19	Pass	Y
776 - 787	Lower	-39.6	-19	Pass	Y
776 - 787	Upper	-39.8	-19	Pass	Y
824 - 849	Lower	-42.6	-19	Pass	Y
824 - 849	Upper	-42.1	-19	Pass	Y
1710 - 1755	Lower	-45.4	-19	Pass	Y
1710 - 1755	Upper	-48.7	-19	Pass	Y
1850 - 1915	Lower	-44.3	-19	Pass	Y
1850 - 1915	Upper	-51.2	-19	Pass	Y

WCDMA Uplink Test Results_ Dedicated Ports
 Refer to table on page 37 for signal paths utilized

Frequency Band (MHz)	Band Edge	Measured Level (dBm)	Limit (dBm)	Result	Oobe Below Limit at Max Input Power (Yes / No)
698 - 716	Lower	-51.9	-19	Pass	Y
698 - 716	Upper	-49.7	-19	Pass	Y
776 - 787	Lower	-43.2	-19	Pass	Y
776 - 787	Upper	-41.3	-19	Pass	Y
824 - 849	Lower	-53.9	-19	Pass	Y
824 - 849	Upper	-49.1	-19	Pass	Y
1710 - 1755	Lower	-43.1	-19	Pass	Y
1710 - 1755	Upper	-44.1	-19	Pass	Y
1850 - 1915	Lower	-41.7	-19	Pass	Y
1850 - 1915	Upper	-47.9	-19	Pass	Y

GSM Downlink Test Results_ Dedicated Ports
 Refer to table on page 37 for signal paths utilized

Frequency Band (MHz)	Band Edge	Measured Level (dBm)	Limit (dBm)	Result	Oobe Below Limit at Max Input Power (Yes / No)
728 - 746 MHz	Lower	-34.9	-19	Pass	Y
728 - 746 MHz	Upper	-28.1	-19	Pass	Y
746 - 757 MHz	Lower	-27.3	-19	Pass	Y
746 - 757 MHz	Upper	-32.5	-19	Pass	Y
869 - 894 MHz	Lower	-36.9	-19	Pass	Y
869 - 894 MHz	Upper	-43.0	-19	Pass	Y
1930 - 1995 MHz	Lower	-42.8	-19	Pass	Y
1930 - 1995 MHz	Upper	-37.4	-19	Pass	Y
2110 - 2155 MHz	Lower	-36.2	-19	Pass	Y
2110 - 2155 MHz	Upper	-35.2	-19	Pass	Y

CDMA Downlink Test Results_ Dedicated Ports
 Refer to table on page 37 for signal paths utilized

Frequency Band (MHz)	Band Edge	Measured Level (dBm)	Limit (dBm)	Result	Oobe Below Limit at Max Input Power (Yes / No)
728 - 746 MHz	Lower	-49.2	-19	Pass	Y
728 - 746 MHz	Upper	-45.6	-19	Pass	Y
746 - 757 MHz	Lower	-48.2	-19	Pass	Y
746 - 757 MHz	Upper	-51.6	-19	Pass	Y
869 - 894 MHz	Lower	-52.2	-19	Pass	Y
869 - 894 MHz	Upper	-51.8	-19	Pass	Y
1930 - 1995 MHz	Lower	-53.1	-19	Pass	Y
1930 - 1995 MHz	Upper	-49.1	-19	Pass	Y
2110 - 2155 MHz	Lower	-53.2	-19	Pass	Y
2110 - 2155 MHz	Upper	-50.7	-19	Pass	Y

WCDMA Downlink Test Results_ Dedicated Ports
 Refer to table on page 37 for signal paths utilized

Frequency Band (MHz)	Band Edge	Measured Level (dBm)	Limit (dBm)	Result	Oobe Below Limit at Max Input Power (Yes / No)
728 - 746 MHz	Lower	-52.1	-19	Pass	Y
728 - 746 MHz	Upper	-45.3	-19	Pass	Y
746 - 757 MHz	Lower	-55.7	-19	Pass	Y
746 - 757 MHz	Upper	-54.1	-19	Pass	Y
869 - 894 MHz	Lower	-49.7	-19	Pass	Y
869 - 894 MHz	Upper	-48.1	-19	Pass	Y
1930 - 1995 MHz	Lower	-49.9	-19	Pass	Y
1930 - 1995 MHz	Upper	-45.6	-19	Pass	Y
2110 - 2155 MHz	Lower	-51.1	-19	Pass	Y
2110 - 2155 MHz	Upper	-50.7	-19	Pass	Y

GSM Uplink Test Results_ Common Ports
 Refer to table on page 37 for signal paths utilized

Frequency Band (MHz)	Band Edge	Measured Level (dBm)	Limit (dBm)	Result	Oobe Below Limit at Max Input Power (Yes / No)
698 - 716	Lower	-27.3	-19	Pass	Y
698 - 716	Upper	-27.7	-19	Pass	Y
776 - 787	Lower	-25.3	-19	Pass	Y
776 - 787	Upper	-25.8	-19	Pass	Y
824 - 849	Lower	-29.3	-19	Pass	Y
824 - 849	Upper	-30.7	-19	Pass	Y

CDMA Uplink Test Results_ Common Ports
 Refer to table on page 37 for signal paths utilized

Frequency Band (MHz)	Band Edge	Measured Level (dBm)	Limit (dBm)	Result	Oobe Below Limit at Max Input Power (Yes / No)
698 - 716	Lower	-49.8	-19	Pass	Y
698 - 716	Upper	-45.7	-19	Pass	Y
776 - 787	Lower	-41.9	-19	Pass	Y
776 - 787	Upper	-40.3	-19	Pass	Y
824 - 849	Lower	-43.1	-19	Pass	Y
824 - 849	Upper	-37.5	-19	Pass	Y

WCDMA Uplink Test Results_ Common Ports
 Refer to table on page 37 for signal paths utilized

Frequency Band (MHz)	Band Edge	Measured Level (dBm)	Limit (dBm)	Result	Oobe Below Limit at Max Input Power (Yes / No)
698 - 716	Lower	-52.3	-19	Pass	Y
698 - 716	Upper	-48.5	-19	Pass	Y
776 - 787	Lower	-44.0	-19	Pass	Y
776 - 787	Upper	-43.1	-19	Pass	Y
824 - 849	Lower	-44.5	-19	Pass	Y
824 - 849	Upper	-48.2	-19	Pass	Y

GSM Downlink Test Results_ Common Ports
 Refer to table on page 37 for signal paths utilized

Frequency Band (MHz)	Band Edge	Measured Level (dBm)	Limit (dBm)	Result	Oobe Below Limit at Max Input Power (Yes / No)
728 - 746 MHz	Lower	-35.1	-19	Pass	Y
728 - 746 MHz	Upper	-30.1	-19	Pass	Y
746 - 757 MHz	Lower	-28.8	-19	Pass	Y
746 - 757 MHz	Upper	-33.9	-19	Pass	Y
869 - 894 MHz	Lower	-36.5	-19	Pass	Y
869 - 894 MHz	Upper	-37.9	-19	Pass	Y

CDMA Downlink Test Results_ Common Ports
 Refer to table on page 37 for signal paths utilized

Frequency Band (MHz)	Band Edge	Measured Level (dBm)	Limit (dBm)	Result	Oobe Below Limit at Max Input Power (Yes / No)
728 - 746 MHz	Lower	-50.4	-19	Pass	Y
728 - 746 MHz	Upper	-46.5	-19	Pass	Y
746 - 757 MHz	Lower	-48.1	-19	Pass	Y
746 - 757 MHz	Upper	-51.9	-19	Pass	Y
869 - 894 MHz	Lower	-52.5	-19	Pass	Y
869 - 894 MHz	Upper	-52.4	-19	Pass	Y

WCDMA Downlink Test Results_ Common Ports
 Refer to table on page 37 for signal paths utilized

Frequency Band (MHz)	Band Edge	Measured Level (dBm)	Limit (dBm)	Result	Oobe Below Limit at Max Input Power (Yes / No)
728 - 746 MHz	Lower	-52.0	-19	Pass	Y
728 - 746 MHz	Upper	-46.7	-19	Pass	Y
746 - 757 MHz	Lower	-53.8	-19	Pass	Y
746 - 757 MHz	Upper	-53.9	-19	Pass	Y
869 - 894 MHz	Lower	-48.9	-19	Pass	Y
869 - 894 MHz	Upper	-48.5	-19	Pass	Y

Annex C Out of Band Emission

Refer to Annex C for Out of Band Emission plots

Conducted Spurious Emissions

Engineer: Greg Corbin

Test Date: 5/30/2019

Test Procedure

The EUT was connected to a spectrum analyzer through an attenuator, with the losses being input into the spectrum analyzer as a combination of reference level offset and correction factor as needed to ensure accurate readings. A signal generator was utilized to produce a 4.1 MHz AWGN signal operating at the maximum allowable power. The conducted spurious emissions from 9 kHz to 10 times the highest tunable frequency for each operational band were measured (excluding the band defined by the Out of band emissions test). The emissions were plotted and the highest level was recorded in the summary table.

Conducted Emissions for the uplink direction was tested with the modem TX on and modem TX off.

For UL Conducted Spurious tests with the Modem ON the measurement was performed from S4 to the dedicated and common donor ports.

For UL Conducted Spurious tests with the modem OFF, only the worst case signal path (as determined from Power / Gain) was tested.

For the DL, all paths were tested per KDB 935210 D03 section 7.15 b)1)ii).

Signal Paths measured for Conducted Spurious Emissions

Conducted Spurious					Conducted Spurious		
Dedicated Ports					Common Ports		
U/L					U/L		
B12	B13	B5	B4	B25	B12	B13	B5
S2 to D3	S2 to D3	S3 to D2	S3 to D1	S4 to D1	S1 to D1	S3 to D1	S3 to D1
D/L					D/L		
B12	B13	B5	B4	B25	B12	B13	B5
D3 to S1	D3 to S1	D2 to S1	D1 to S1	D1 to S1	D1 to S1	D1 to S1	D1 to S1
D3 to S2	D3 to S2	D2 to S2	D1 to S2	D1 to S2	D1 to S2	D1 to S2	D1 to S2
D3 to S3	D3 to S3	D2 to S3	D1 to S3	D1 to S3	D1 to S3	D1 to S3	D1 to S3
D3 to S4	D3 to S4	D2 to S4	D1 to S4	D1 to S4	D1 to S4	D1 to S4	D1 to S4

The following formulas are used for calculating the limits.

Conducted Spurious Emissions Limit = $P1 - (43 + 10\text{Log}(P2)) = -13 \text{ dBm}$

P1 = power in dBm

P2 = power in Watts

Test Setup

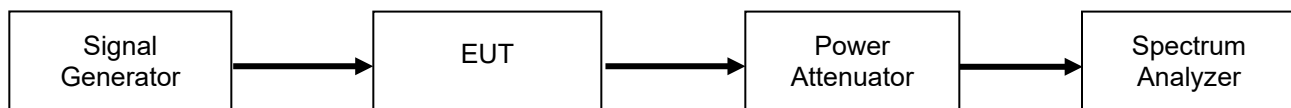

**Uplink Test Results
Dedicated Port_ Modem Off**

Frequency Band (MHz)	Measured Frequency (MHz)	Measured Level (dBm)	Limit (dBm)	Result
698 - 716	6105	-31.3	-13	Pass
776 - 787	781.1	-27.3	-13	Pass
824 - 849	8358.4	-30.4	-13	Pass
1710 - 1755	15530.2	-27.4	-13	Pass
1850 - 1915	16771.6	-27.1	-13	Pass

**Uplink Test Results
Dedicated Port_ Modem On**

Frequency Band (MHz)	Measured Frequency (MHz)	Measured Level (dBm)	Limit (dBm)	Result
698 - 716	716.9	-29.3	-13	Pass
776 - 787	787.1	-25.9	-13	Pass
824 - 849	851.9	-26.6	-13	Pass
1710 - 1755	15201.5	-27.5	-13	Pass
1850 - 1915	15504	-27.2	-13	Pass

**Uplink Test Results
Common Port_ Modem Off**

Frequency Band (MHz)	Measured Frequency (MHz)	Measured Level (dBm)	Limit (dBm)	Result
698 - 716	6922.8	-32.9	-13	Pass
776 - 787	5985.7	-31.5	-13	Pass
824 - 849	1725.92	-31.4	-13	Pass

**Uplink Test Results
Common Port_ Modem On**

Frequency Band (MHz)	Measured Frequency (MHz)	Measured Level (dBm)	Limit (dBm)	Result
698 - 716	716.1	-32	-13	Pass
776 - 787	775.9	-29.8	-13	Pass
824 - 849	850	-27.6	-13	Pass

**Downlink Test Results
Dedicated Donor Port to Server Port 1**

Frequency Band (MHz)	Measured Frequency (MHz)	Measured Level (dBm)	Limit (dBm)	Result
728 - 746	1989.6	-31	-13	Pass
746 - 757	2153.1	-29.3	-13	Pass
869 - 894	8419.5	-31.4	-13	Pass
1930 - 1995	19961.7	-26.1	-13	Pass
2110 - 2155	20197.5	-25.4	-13	Pass

**Downlink Test Results
Dedicated Donor Port to Server Port 2**

Frequency Band (MHz)	Measured Frequency (MHz)	Measured Level (dBm)	Limit (dBm)	Result
728 - 746	2150.1	-31.5	-13	Pass
746 - 757	2123.1	-30.5	-13	Pass
869 - 894	8575.5	-31.5	-13	Pass
1930 - 1995	19871.7	-26.2	-13	Pass
2110 - 2155	21444.4	-25.9	-13	Pass

**Downlink Test Results
Dedicated Donor Port to Server Port 3**

Frequency Band (MHz)	Measured Frequency (MHz)	Measured Level (dBm)	Limit (dBm)	Result
728 - 746	6434.6	-31.6	-13	Pass
746 - 757	7473.4	-32.1	-13	Pass
869 - 894	8887.5	-30.9	-13	Pass
1930 - 1995	19950.5	-25.9	-13	Pass
2110 - 2155	19893.7	-25.4	-13	Pass

**Downlink Test Results
Dedicated Donor Port to Server Port 4**

Frequency Band (MHz)	Measured Frequency (MHz)	Measured Level (dBm)	Limit (dBm)	Result
728 - 746	1965.1	-31.5	-13	Pass
746 - 757	1969.1	-31	-13	Pass
869 - 894	8315.1	-31.4	-13	Pass
1930 - 1995	19903.2	-26.4	-13	Pass
2110 - 2155	21225.7	-25.6	-13	Pass

**Downlink Test Results
Common Donor Port 1 to Server Port 1**

Frequency Band (MHz)	Measured Frequency (MHz)	Measured Level (dBm)	Limit (dBm)	Result
728 - 746	2152.6	-30.3	-13	Pass
746 - 757	1990.5	-30.3	-13	Pass
869 - 894	8368.8	-30.5	-13	Pass

**Downlink Test Results
Common Donor Port 1 to Server Port 2**

Frequency Band (MHz)	Measured Frequency (MHz)	Measured Level (dBm)	Limit (dBm)	Result
728 - 746	1966.4	-30.1	-13	Pass
746 - 757	1970.9	-31.7	-13	Pass
869 - 894	7291.9	-30.6	-13	Pass

**Downlink Test Results
Common Donor Port 1 to Server Port 3**

Frequency Band (MHz)	Measured Frequency (MHz)	Measured Level (dBm)	Limit (dBm)	Result
728 - 746	6460.4	-31.3	-13	Pass
746 - 757	7492.2	-31.1	-13	Pass
869 - 894	1946.6	-31.2	-13	Pass

Downlink Test Results
Common Donor Port 1 to Server Port 4

Frequency Band (MHz)	Measured Frequency (MHz)	Measured Level (dBm)	Limit (dBm)	Result
728 - 746	6194.4	-32	-13	Pass
746 - 757	7473.4	-31.6	-13	Pass
869 - 894	8332.4	-31.4	-13	Pass

For the 746 – 758 downlink and 776 – 788 Uplink bands of operation, the following additional spurious emissions requirements apply.

FCC 27.53(c)

For operations in the 746-758 MHz band and the 776-788 MHz band, the power of any emission outside the licensee's frequency band(s) of operation shall be attenuated below the transmitter power (P) within the licensed band(s) of operation, measured in watts, in accordance with the following:

(3) On all frequencies between 763-775 MHz and 793-805 MHz, by a factor not less than $76 + 10 \log (P)$ dB in a 6.25 kHz band segment, for base and fixed stations;

**776 – 787 MHz Uplink Band
Server port 2 to Dedicated Port 3**

Spurious Frequency Range (MHz)	Measured Frequency (MHz)	Measured Value (dBm)	RBW (kHz)	Final Value (dBm)	Limit (dBm)	Margin (dB)
763 – 775	774.88	-50.7	6.25	-50.70	-46	-4.70
793 – 805	793.06	-58.4	6.25	-58.40	-46	-12.40

**776 – 787 MHz Uplink Band
Server port 3 to Common Port 1**

Spurious Frequency Range (MHz)	Measured Frequency (MHz)	Measured Value (dBm)	RBW (kHz)	Final Value (dBm)	Limit (dBm)	Margin (dB)
763 – 775	774.991	-52.1	6.25	-52.10	-46	-6.10
793 – 805	804.184	-56.1	6.25	-56.10	-46	-10.10

**746 - 757 MHz Downlink Band
Dedicated Port 3 to Server Port 1**

Spurious Frequency Range (MHz)	Measured Frequency (MHz)	Measured Value (dBm)	RBW (kHz)	Final Value (dBm)	Limit (dBm)	Margin (dB)
763 – 775	763.076	-71.3	6.25	-71.30	-46	-25.30
793 – 805	794.694	-73.3	6.25	-73.30	-46	-27.30

**746 - 757 MHz Downlink Band
Dedicated Port 3 to Server Port 2**

Spurious Frequency Range (MHz)	Measured Frequency (MHz)	Measured Value (dBm)	RBW (kHz)	Final Value (dBm)	Limit (dBm)	Margin (dB)
763 – 775	763.175	-72.1	6.25	-72.10	-46	-26.10
793 – 805	796.48	-73	6.25	-73.00	-46	-27.00

**746 - 757 MHz Downlink Band
Dedicated Port 3 to Server Port 3**

Spurious Frequency Range (MHz)	Measured Frequency (MHz)	Measured Value (dBm)	RBW (kHz)	Final Value (dBm)	Limit (dBm)	Margin (dB)
763 – 775	763.175	-72.1	6.25	-72.10	-46	-26.10
793 – 805	796.48	-73	6.25	-73.00	-46	-27.00



763 – 775	774.385	-72.1	6.25	-72.10	-46	-26.10
793 – 805	800.434	-73.3	6.25	-73.30	--46	-27.30

**746 - 757 MHz Downlink Band
Dedicated Port 3 to Server Port 4**

Spurious Frequency Range (MHz)	Measured Frequency (MHz)	Measured Value (dBm)	RBW (kHz)	Final Value (dBm)	Limit (dBm)	Margin (dB)
763 – 775	763.027	-72.6	6.25	-72.60	-46	-26.60
793 – 805	795.912	-72.7	6.25	-72.70	--46	-26.70

**746 - 757 MHz Downlink Band
Common Port 1 to Server Port 1**

Spurious Frequency Range (MHz)	Measured Frequency (MHz)	Measured Value (dBm)	RBW (kHz)	Final Value (dBm)	Limit (dBm)	Margin (dB)
763 – 775	766.315	-72.3	6.25	-72.30	-46	-26.30
793 – 805	803.888	-72.5	6.25	-72.50	--46	-26.50

**746 - 757 MHz Downlink Band
Common Port 1 to Server Port 2**

Spurious Frequency Range (MHz)	Measured Frequency (MHz)	Measured Value (dBm)	RBW (kHz)	Final Value (dBm)	Limit (dBm)	Margin (dB)
763 – 775	763.132	-71.4	6.25	-71.40	-46	-25.40
793 – 805	801.685	-72.8	6.25	-72.80	--46	-26.80

**746 - 757 MHz Downlink Band
Common Port 1 to Server Port 3**

Spurious Frequency Range (MHz)	Measured Frequency (MHz)	Measured Value (dBm)	RBW (kHz)	Final Value (dBm)	Limit (dBm)	Margin (dB)
763 – 775	763.244	-71.3	6.25	-71.30	-46	-25.30
793 – 805	798.814	-73	6.25	-73.00	--46	-27.00

**746 - 757 MHz Downlink Band
Common Port 1 to Server Port 4**

Spurious Frequency Range (MHz)	Measured Frequency (MHz)	Measured Value (dBm)	RBW (kHz)	Final Value (dBm)	Limit (dBm)	Margin (dB)
763 – 775	763.051	-72	6.25	-72.00	-46	-26.00
793 – 805	794.558	-70.9	6.25	-70.90	--46	-24.90

FCC 27.53(e)

For operations in the 746-758 MHz, 775-788 MHz, and 805-806 MHz bands, emissions in the band 1559-1610 MHz shall be limited to -70 dBW/MHz equivalent isotropically radiated power (EIRP) for wideband signals, and -80 dBW EIRP for discrete emissions of less than 700 Hz bandwidth. For the purpose of equipment authorization, a transmitter shall be tested with an antenna that is representative of the type that will be used with the equipment in normal operation.

Since the limit is referenced to EIRP, the final data is computed using the Conducted Spurious Emission data and adding the BW correction factor plus the final gain/loss data from the antenna kitting information supplied by the manufacturer.

Final Value (dBm) = conducted measurement + final gain/loss from Antenna Kitting document

The Limit for discreet (narrowband) emissions is -80dBW (-50 dBm) in 700 MHz BW.

The Limit for (wideband Emissions) is -70 dBW (-40 dBm) in a 1 MHz BW.

**776 – 787 MHz Uplink Band
Server port 2 to Dedicated Port 3**

Spurious Frequency Range (MHz)	Measured Frequency (MHz)	Measured Value (dBm)	RBW	Gain/Loss from Antenna Kitting Information (dB)	Final Value (dBm)	Limit (dBm)	Margin (dB)
1559 – 1610 (Wideband)	1590.23	-51.9	1 MHz	3.21	-48.69	-40	-8.69
1559 – 1610 (Narrowband)	1563.49	-63.4	700 Hz	3.21	-60.19	-50	-10.19

**776 – 787 MHz Uplink Band
Server port 3 to Common Port 1**

Spurious Frequency Range (MHz)	Measured Frequency (MHz)	Measured Value (dBm)	Bandwidth Correction Factor (dB)	Gain/Loss from Antenna Kitting Information (dB)	Final Value (dBm)	Limit (dBm)	Margin (dB)
1559 – 1610 (Wideband)	1608.34	-51.9	1 MHz	3.21	-48.69	-40	-8.69
1559 – 1610 (Narrowband)	1561.9	-64.4	700 Hz	3.21	-61.19	-50	-11.19

**746 - 757 MHz Downlink Band
Dedicated Port 3 to Server Port 1**

Spurious Frequency Range (MHz)	Measured Frequency (MHz)	Measured Value (dBm)	Bandwidth Correction Factor (dB)	Gain/Loss from Antenna Kitting Information (dB)	Final Value (dBm)	Limit (dBm)	Margin (dB)
1559 – 1610 (Wideband)	1590.37	-52.6	1 MHz	-1.69	-54.29	-40	-14.29
1559 – 1610 (Narrowband)	1594.88	-81.9	700 Hz	-1.69	-83.59	-50	-33.59

**746 - 757 MHz Downlink Band
Dedicated Port 3 to Server Port 2**

Spurious Frequency Range (MHz)	Measured Frequency (MHz)	Measured Value (dBm)	Bandwidth Correction Factor (dB)	Gain/Loss from Antenna Kitting Information (dB)	Final Value (dBm)	Limit (dBm)	Margin (dB)
1559 – 1610 (Wideband)	1560.63	-52.6	1 MHz	-1.69	-54.29	-40	-14.29
1559 – 1610 (Narrowband)	1570.27	-82	700 Hz	-1.69	-83.69	-50	-33.69



**746 - 757 MHz Downlink Band
Dedicated Port 3 to Server Port 3**

Spurious Frequency Range (MHz)	Measured Frequency (MHz)	Measured Value (dBm)	Bandwidth Correction Factor (dB)	Gain/Loss from Antenna Kitting Information (dB)	Final Value (dBm)	Limit (dBm)	Margin (dB)
1559 – 1610 (Wideband)	1604.39	-52.1	1 MHz	-1.69	-53.79	-40	-13.79
1559 – 1610 (Narrowband)	1601.12	-82.4	700 Hz	-1.69	-84.09	-50	-34.09

**746 - 757 MHz Downlink Band
Dedicated Port 3 to Server Port 4**

Spurious Frequency Range (MHz)	Measured Frequency (MHz)	Measured Value (dBm)	Bandwidth Correction Factor (dB)	Gain/Loss from Antenna Kitting Information (dB)	Final Value (dBm)	Limit (dBm)	Margin (dB)
1559 – 1610 (Wideband)	1608.39	-51.5	1 MHz	-1.69	-53.19	-40	-13.19
1559 – 1610 (Narrowband)	1605.12	-82	700 Hz	-1.69	-83.69	-50	-33.69

**746 - 757 MHz Downlink Band
Common Port 1 to Server Port 1**

Spurious Frequency Range (MHz)	Measured Frequency (MHz)	Measured Value (dBm)	Bandwidth Correction Factor (dB)	Gain/Loss from Antenna Kitting Information (dB)	Final Value (dBm)	Limit (dBm)	Margin (dB)
1559 – 1610 (Wideband)	1602.14	-52.1	1 MHz	-1.69	-53.79	-40	-13.79
1559 – 1610 (Narrowband)	1591.54	-82.1	700 Hz	-1.69	-83.79	-50	-33.79

**746 - 757 MHz Downlink Band
Common Port 1 to Server Port 2**

Spurious Frequency Range (MHz)	Measured Frequency (MHz)	Measured Value (dBm)	Bandwidth Correction Factor (dB)	Gain/Loss from Antenna Kitting Information (dB)	Final Value (dBm)	Limit (dBm)	Margin (dB)
1559 – 1610 (Wideband)	1584.13	-51.9	1 MHz	-1.69	-53.59	-40	-13.59
1559 – 1610 (Narrowband)	1560.17	-81.5	700 Hz	-1.69	-83.19	-50	-33.19

**746 - 757 MHz Downlink Band
Common Port 1 to Server Port 3**

Spurious Frequency Range (MHz)	Measured Frequency (MHz)	Measured Value (dBm)	Bandwidth Correction Factor (dB)	Gain/Loss from Antenna Kitting Information (dB)	Final Value (dBm)	Limit (dBm)	Margin (dB)
1559 – 1610 (Wideband)	1581.29	-51.6	1 MHz	-1.69	-53.29	-40	-13.29
1559 – 1610 (Narrowband)	1560.96	-81.9	700 Hz	-1.69	-83.59	-50	-33.59

**746 - 757 MHz Downlink Band
Common Port 1 to Server Port 4**

Spurious Frequency Range (MHz)	Measured Frequency (MHz)	Measured Value (dBm)	Bandwidth Correction Factor (dB)	Gain/Loss from Antenna Kitting Information (dB)	Final Value (dBm)	Limit (dBm)	Margin (dB)
1559 – 1610 (Wideband)	1592.34	-52.9	1 MHz	-1.69	-54.59	-40	-14.59
1559 – 1610 (Narrowband)	1579.68	-81.9	700 Hz	-1.69	-83.59	-50	-33.59

Annex D Conducted Spurious Emission

Refer to Annex D for Conducted Spurious Emission plots.

Noise Limits

Engineer: Greg Corbin

Test Date: 5/1/2019

Test Procedure

The EUT was connected to a spectrum analyzer through an attenuator with the losses being input into the spectrum analyzer as a combination of reference level offset and correction factor as necessary to ensure that accurate readings were obtained. A series of three tests were performed: the maximum uplink and downlink noise, the variable noise for the uplink and downlink in the presence of a downlink signal, and the variable uplink noise timing. The detailed procedures from the latest version of KDB 935210 D03 were followed.

For the Uplink, measured each band thru the dedicated port, then measured each band on the common port.
 For the Downlink, measured each band on each server port.

Signal Paths measured for Noise Limits

Noise Power				
Dedicated Ports				
U/L				
B12	B13	B5	B4	B25
D3	D3	D2	D1	D1
D/L				
B12	B13	B5	B4	B25
S1	S1	S1	S1	S1
S2	S2	S2	S2	S2
S3	S3	S3	S3	S3
S4	S4	S4	S4	S4
Common Ports				
U/L				
B12	B13	B5	B4	B25
D1	D1	D1	D1	D1

Variable Noise Power and Timing

Reviewed all the power and gain data and selected the worst case (highest gain and output power) and measured the variable noise power and gain on that port.

The dedicated ports had the highest power and gain on the uplink.

Recorded variable noise and gain from Server port 2 to dedicated Port.

Recorded variable noise for the B12, B13, B5 common port from Server Port 1 to Common Port 1.

The following formulas are used for calculating the limits. Note – Downlink noise power limit is calculated with the center frequency of the associated uplink band.

Noise Power = $-102.5 + \text{LOG}_{10}(\text{Band Center Frequency}) * 20$

Variable Noise = $-103 \text{ dBm/MHz-RSSI}$

Test Setup

Maximum Noise Power



Variable Uplink Noise Power and Timing

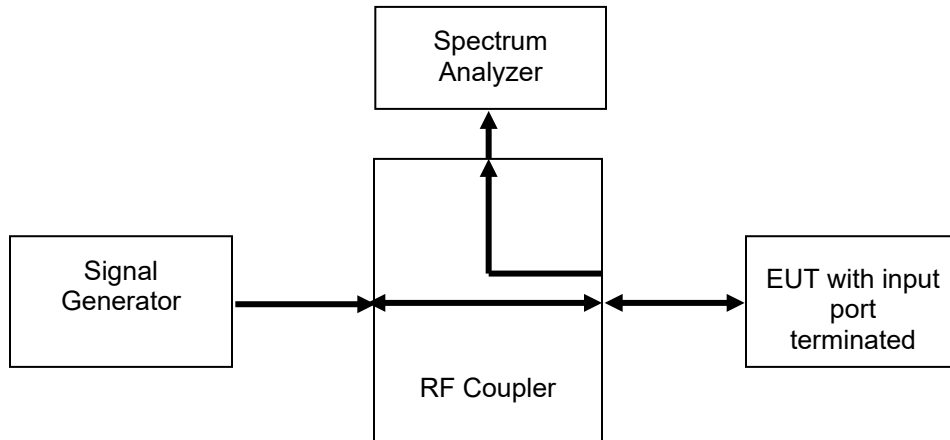

**Maximum Uplink Noise Test Results
Dedicated Ports**

Frequency Band (MHz)	Measured Noise (dBm)	Limit (dBm)	Margin (dB)	Result
698 - 716	-48.7	-45.5	-3.2	Pass
776 - 787	-46.5	-44.6	-1.9	Pass
824 - 849	-45.3	-44.1	-1.2	Pass
1710 - 1755	-39.5	-37.7	-1.8	Pass
1850 - 1915	-38.5	-37.0	-1.5	Pass

**Maximum Uplink Noise Test Results
Common Port 1**

Frequency Band (MHz)	Measured Noise (dBm)	Limit (dBm)	Margin (dB)	Result
698 - 716	-50	-45.5	-4.5	Pass
776 - 787	-47.1	-44.6	-2.5	Pass
824 - 849	-45.9	-44.1	-1.8	Pass
1710 - 1755	-39.5	-37.7	-1.8	Pass
1850 - 1915	-37.8	-37.0	-0.8	Pass

**Maximum Downlink Noise Test Results
Server Port 1**

Frequency Band (MHz)	Measured Noise (dBm)	Limit (dBm)	Margin (dB)	Result
728 - 746	-48.4	-45.5	-2.9	Pass
746 - 757	-48.2	-44.6	-3.6	Pass
869 - 894	-48.5	-44.1	-4.4	Pass
1930 - 1995	-38	-37.0	-1.0	Pass
2110 - 2155	-39.7	-37.7	-2.0	Pass

**Maximum Downlink Noise Test Results
Server Port 2**

Frequency Band (MHz)	Measured Noise (dBm)	Limit (dBm)	Margin (dB)	Result
728 - 746	-48.2	-45.5	-2.7	Pass
746 - 757	-47.9	-44.6	-3.3	Pass
869 - 894	-48	-44.1	-3.9	Pass
1930 - 1995	-38.3	-37.0	-1.3	Pass
2110 - 2155	-39.8	-37.7	-2.1	Pass

**Maximum Downlink Noise Test Results
Server Port 3**

Frequency Band (MHz)	Measured Noise (dBm)	Limit (dBm)	Margin (dB)	Result
728 - 746	-47.9	-45.5	-2.4	Pass
746 - 757	-47.6	-44.6	-3.0	Pass
869 - 894	-48.3	-44.1	-4.2	Pass
1930 - 1995	-38.4	-37.0	-1.4	Pass
2110 - 2155	-39.6	-37.7	-1.9	Pass

**Maximum Downlink Noise Test Results
Server Port 4**

Frequency Band (MHz)	Measured Noise (dBm)	Limit (dBm)	Margin (dB)	Result
728 - 746	-48	-45.5	-2.5	Pass
746 - 757	-47.5	-44.6	-2.9	Pass
869 - 894	-48.4	-44.1	-4.3	Pass
1930 - 1995	-39.7	-37.0	-2.7	Pass
2110 - 2155	-40.6	-37.7	-2.9	Pass

Uplink Noise Timing Test Results

Frequency Band (MHz)	Measured Timing (Seconds)	Limit (Seconds)	Result
698 - 716	1.11	3.0	Pass
776 - 787	0.83	3.0	Pass
824 - 849	1.70	3.0	Pass
1710 - 1755	1.59	3.0	Pass
1850 - 1915	1.54	3.0	Pass

Annex E Noise Limits and Uplink Noise Timing

Refer to Annex E for Noise Limits and Uplink Noise Timing Plots



**Variable Uplink Noise Limit Test Results
Dedicated Ports**

698 - 716 MHz

Server Port 2 to Dedicated Port 3

RSSI (dBm)	Noise Limit (dBm)	Measured Noise (dBm)	Margin (dB)
-62.0	-45.5	-48.4	-2.9
-60.0	-45.5	-48.2	-2.7
-57.0	-46.0	-48.6	-2.6
-56.0	-47.0	-49.3	-2.3
-55.0	-48.0	-50.5	-2.5
-54.0	-49.0	-51.6	-2.6

776 - 787 MHz

Server Port 2 to Dedicated Port 3

RSSI (dBm)	Noise Limit (dBm)	Measured Noise (dBm)	Margin (dB)
-64.0	-44.6	-45.3	-0.7
-63.0	-44.6	-45.6	-1.0
-58.0	-45.0	-45.8	-0.8
-57.0	-46.0	-46.7	-0.7
-53.0	-50.0	-51.2	-1.2
-52.0	-51.0	-52.1	-1.1

824 - 849 MHz

Server Port 3 to Dedicated Port 2

RSSI (dBm)	Noise Limit (dBm)	Measured Noise (dBm)	Margin (dB)
-64.0	-44.1	-46.2	-2.1
-62.0	-44.1	-46.2	-2.1
-61.0	-44.1	-46.1	-2.0
-58.0	-45.0	-47.7	-2.7
-57.0	-46.0	-48.7	-2.7
-56.0	-47.0	-50.5	-3.5

1710 - 1755 MHz

Server Port 3 to Dedicated Port 1

RSSI (dBm)	Noise Limit (dBm)	Measured Noise (dBm)	Margin (dB)
-65.0	-38.0	-39.8	-1.8
-64.0	-39.0	-40.3	-1.3
-63.0	-40.0	-41.2	-1.2
-62.0	-41.0	-42.3	-1.3
-61.0	-42.0	-42.9	-0.9
-59.0	-44.0	-45.1	-1.1



**1850 - 1915 MHz
Server Port 3 to Dedicated Port 1**

RSSI (dBm)	Noise Limit (dBm)	Measured Noise (dBm)	Margin (dB)
-72.0	-37.0	-40.4	-3.4
-71.0	-37.0	-40.4	-3.4
-70.0	-37.0	-40.5	-3.5
-66.0	-37.0	-45.8	-8.8
-65.0	-38.0	-46.8	-8.8
-64.0	-39.0	-47.7	-8.7

Common Port

**698 - 716 MHz
Server Port 2 to Common Port 1**

RSSI (dBm)	Noise Limit (dBm)	Measured Noise (dBm)	Margin (dB)
-56.0	-47.0	-51.6	-4.6
-55.0	-48.0	-50.7	-2.7
-54.0	-49.0	-53.3	-4.3
-53.0	-50.0	-54.6	-4.6
-52.0	-51.0	-55	-4.0
-51.0	-52.0	-56.5	-4.5

**776 - 787 MHz
Server Port 3 to Common Port 1**

RSSI (dBm)	Noise Limit (dBm)	Measured Noise (dBm)	Margin (dB)
-57.0	-46.0	-46.8	-0.8
-56.0	-47.0	-47.9	-0.9
-55.0	-48.0	-49.3	-1.3
-53.0	-50.0	-51	-1.0
-52.0	-51.0	-52	-1.0
-51.0	-52.0	-52.8	-0.8

**824 - 849 MHz
Server Port 3 to Common Port 1**

RSSI (dBm)	Noise Limit (dBm)	Measured Noise (dBm)	Margin (dB)
-62.0	-44.1	-47.1	-3.0
-61.0	-44.1	-47.1	-3.0
-58.0	-45.0	-48.3	-3.3
-57.0	-46.0	-49.5	-3.5
-55.0	-48.0	-50.7	-2.7
-54.0	-49.0	-52.3	-3.3

Uplink Inactivity

Engineer: Greg Corbin

Test Date: 5/31/2019

Test Procedure

The EUT was connected directly to a spectrum analyzer set to operate in the center of the EUT operational uplink and downlink bands. The span was set to 0 Hz with a sweep time of 330 seconds and MAX HOLD operation. The EUT was powered on and the time for the uplink to return to an inactive state was measured using the DELTA MARKER method to ensure that it was less than 300 seconds. The noise level after the return to an inactive state was less than -70 dBm/MHz.

The server ports were terminated with 50 ohms.

The Uplink Inactivity was measured at the Dedicated Donor Port outputs.

Test Setup

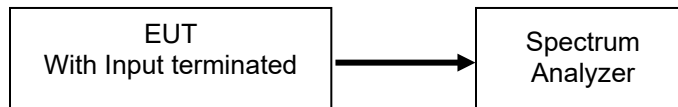

Uplink Test Results

Frequency Band (MHz)	Measured Time (Seconds)	Limit (Seconds)	Result
698 - 716	282.2	300	Pass
776 - 787	282.1	300	Pass
824 - 849	281.75	300	Pass
1710 - 1755	285.687	300	Pass
1850 - 1915	286.1	300	Pass

Annex F Uplink Inactivity

Refer to Annex F for Uplink Inactivity Plots

Variable Gain

Engineer: Greg Corbin

Test Date: 5/7/2019

Test Procedure

The EUT was connected to a spectrum analyzer through an attenuator with the losses being input into the spectrum analyzer as a combination of reference level offset and correction factor in order to ensure accurate readings were obtained. The uplink gain in the presence of a downlink signal was measured for each operational uplink band using the detailed procedures from the latest version of KDB 935210 D03.

For the Uplink variable gain and gain timing, the test was performed on each band thru the dedicated port and the measurement was repeated for Bands 5, 12 and 13 on the common port. Reviewed all the power and gain data and selected the worst case (highest gain and output power) and measured the variable noise power and gain on that port.

Signal Paths measured for Variable Gain and Gain Timing

Variable Gain and Gain Timing				
Dedicated Ports				
U/L				
B12	B13	B5	B4	B25
S2 to D3	S2 to D3	S3 to D2	S3 to D1	S4 to D1
Common Ports				
U/L				
B12	B13	B5		
S1 to D1	S3 to D1	S3 to D1		

The following formula is used for calculating the limits:

$$\text{Variable Gain} = -34 \text{ dB} - \text{RSSI} + \text{MSCL}$$

Test Setup

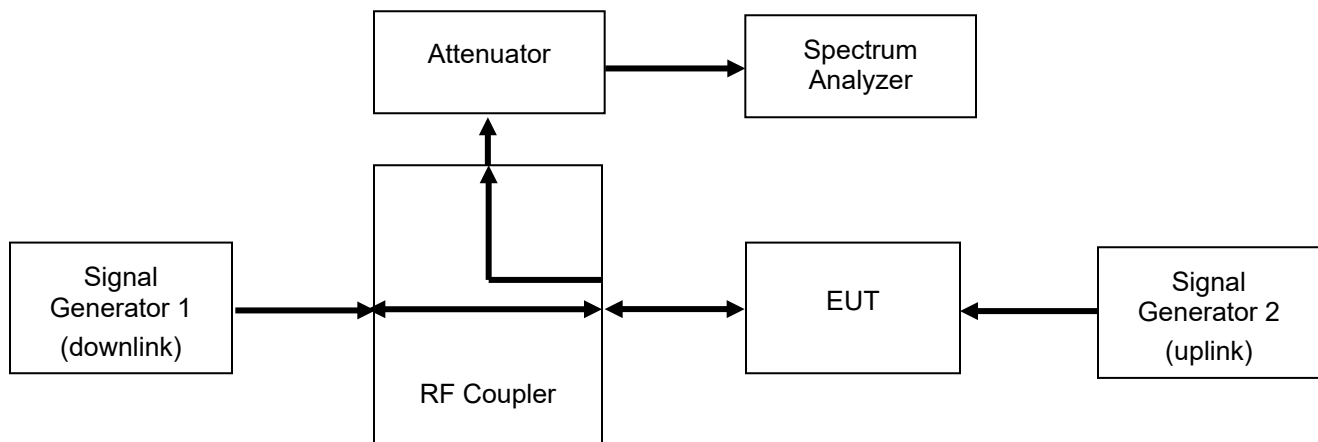

Uplink Test Results

698 - 716 MHz Server Port 2 to Dedicated Donor Port 3

RSSI (dBm)	MSCL (dB)	Gain Limit (dBm)	P(in) (dBm)	P(out) (dBm)	Gain (dB)	Margin (dB)
-58.0	40.2	63.5	-37.5	17.0	54.5	-9.0
-57.0	40.2	63.2	-37.5	17.0	54.5	-8.7
-56.0	40.2	62.2	-37.5	16.5	54.0	-8.2
-55.0	40.2	61.2	-37.5	15.0	52.5	-8.7
-54.0	40.2	60.2	-37.5	13.4	50.9	-9.3
-53.0	40.2	59.2	-37.5	12.4	49.9	-9.3

776 - 787 MHz Server Port 2 to Dedicated Donor Port 3

RSSI (dBm)	MSCL (dB)	Gain Limit (dBm)	P(in) (dBm)	P(out) (dBm)	Gain (dB)	Margin (dB)
-60.0	40.3	64.0	-38.4	16.4	54.8	-9.2
-59.0	40.3	64.0	-38.4	16.4	54.8	-9.2
-58.0	40.3	64.0	-38.4	16.4	54.8	-9.2
-57.0	40.3	63.3	-38.4	15.8	54.2	-9.1
-56.0	40.3	62.3	-38.4	14.2	52.6	-9.7
-55.0	40.3	61.3	-38.4	13.1	51.5	-9.8

824 - 849 MHz Server Port 3 to Dedicated Donor Port 2

RSSI (dBm)	MSCL (dB)	Gain Limit (dBm)	P(in) (dBm)	P(out) (dBm)	Gain (dB)	Margin (dB)
-61.0	42.3	65.0	-37.4	20.1	57.5	-7.5
-60.0	42.3	65.0	-37.4	20.1	57.5	-7.5
-59.0	42.3	65.0	-37.4	19.0	56.4	-8.6
-58.0	42.3	65.0	-37.4	17.9	55.3	-9.7
-57.0	42.3	65.0	-37.4	17.0	54.4	-10.6
-56.0	42.3	64.3	-37.4	15.4	52.8	-11.5

1710 - 1755 MHz Server Port 3 to Dedicated Donor Port 1

RSSI (dBm)	MSCL (dB)	Gain Limit (dBm)	P(in) (dBm)	P(out) (dBm)	Gain (dB)	Margin (dB)
-67.0	45.8	71.0	-45.8	18.2	64.0	-7.0
-66.0	45.8	71.0	-45.8	18.2	64.0	-7.0
-65.0	45.8	71.0	-45.8	18.2	64.0	-7.0
-64.0	45.8	75.8	-45.8	17.7	63.5	-12.3
-63.0	45.8	74.8	-45.8	16.7	62.5	-12.3
-62.0	45.8	73.8	-45.8	15.2	61.0	-12.8

1850 - 1915 MHz
Server Port 4 to Dedicated Donor Port 1

RSSI (dBm)	MSCL (dB)	Gain Limit (dBm)	P(in) (dBm)	P(out) (dBm)	Gain (dB)	Margin (dB)
-67.0	47.5	72.0	-43.5	14.2	57.7	-14.3
-66.0	47.5	72.0	-43.5	13.2	56.7	-15.3
-65.0	47.5	72.0	-43.5	11.6	55.1	-16.9
-64.0	47.5	72.0	-43.5	10.5	54.0	-18.0
-63.0	47.5	72.0	-43.5	8.8	52.3	-19.7
-62.0	47.5	72.0	-43.5	7.8	51.3	-20.7

698 - 716 MHz
Server Port 1 to Common Donor Port 1

RSSI (dBm)	MSCL (dB)	Gain Limit (dBm)	P(in) (dBm)	P(out) (dBm)	Gain (dB)	Margin (dB)
-56.0	40.2	62.2	-37.7	16.4	54.1	-8.1
-55.0	40.2	61.2	-37.7	15.4	53.1	-8.1
-54.0	40.2	60.2	-37.7	13.7	51.4	-8.7
-53.0	40.2	59.2	-37.7	12.7	50.4	-8.7
-52.0	40.2	58.2	-37.7	11.2	48.9	-9.2
-51.0	40.2	57.2	-37.7	10.2	47.9	-9.2

776 - 787 MHz
Server Port 3 to Common Donor Port 1

RSSI (dBm)	MSCL (dB)	Gain Limit (dBm)	P(in) (dBm)	P(out) (dBm)	Gain (dB)	Margin (dB)
-58.0	40.3	64.0	-38.5	15.6	54.1	-9.9
-57.0	40.3	63.3	-38.5	15.6	54.1	-9.2
-56.0	40.3	62.3	-38.5	14.6	53.1	-9.2
-55.0	40.3	61.3	-38.5	13.4	51.9	-9.4
-54.0	40.3	60.3	-38.5	11.9	50.4	-9.9
-53.0	40.3	59.3	-38.5	10.8	49.3	-10.0

824 - 849 MHz
Server Port 3 to Common Donor Port 1

RSSI (dBm)	MSCL (dB)	Gain Limit (dBm)	P(in) (dBm)	P(out) (dBm)	Gain (dB)	Margin (dB)
-60.0	42.3	65.0	-38.2	18.6	56.8	-8.2
-59.0	42.3	65.0	-38.2	18.1	56.3	-8.7
-58.0	42.3	65.0	-38.2	17.0	55.2	-9.8
-57.0	42.3	65.0	-38.2	15.5	53.7	-11.3
-56.0	42.3	64.3	-38.2	14.4	52.6	-11.7
-55.0	42.3	63.3	-38.2	13.4	51.6	-11.7

Uplink Gain Timing Test Results

Dedicated Ports

Frequency Band (MHz)	Measured Timing (Seconds)	Limit (Seconds)	Result
704 - 716	0.59	3.0	Pass
776 - 787	1.06	3.0	Pass
824 - 849	1.57	3.0	Pass
1710 - 1755	1.79	3.0	Pass
1850 - 1915	1.16	3.0	Pass

Common Port

Frequency Band (MHz)	Measured Timing (Seconds)	Limit (Seconds)	Result
704 - 716	0.51	3.0	Pass
776 - 787	0.95	3.0	Pass
824 - 849	1.36	3.0	Pass

Annex G Uplink Gain Timing

Refer to Annex G for Uplink Gain Timing Plots

Occupied Bandwidth

Engineer: Greg Corbin

Test Date: 5/16/2019

Test Procedure

The EUT was connected to a spectrum analyzer through an attenuator with the losses being input into the spectrum analyzer as a combination of reference level offset and correction factor as required to ensure that accurate readings were obtained. A signal generator was utilized to produce the following signals: GSM, CDMA, and WCDMA. The signal generator was tuned to the center channel of each of the EUT operational uplink and downlink bands with the RF level set at a point just prior to the AGC being in control of the power. For each modulation type, the input and output signal was measured and plotted to ensure that the signals were similar.

Occupied Bandwidth was only tested from Server Port 1 to Dedicated Ports.
 OCC BW for Common and Dedicated Ports will look the same and no need to test both.

Signal Paths measured for Occupied BW

Occupied BW				
U/L				
B12	B13	B5	B4	B25
S1 to D3	S1 to D3	S1 to D2	S1 to D1	S1 to D1
D/L				
B12	B13	B5	B4	B25
D3 to S1	D3 to S1	D2 to S1	D1 to S1	D1 to S1

Test Setup

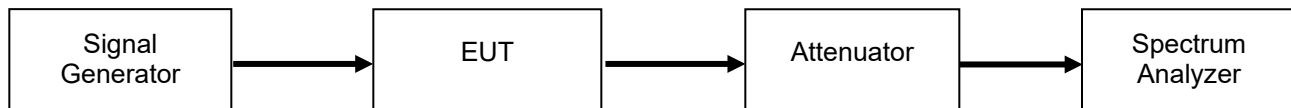

Annex H Occupied Bandwidth

Refer to Annex H for Occupied Bandwidth plots

Anti-Oscillation

Engineer: Greg Corbin

Test Date: 5/16/2019

Test Procedure

The EUT was connected to a spectrum analyzer set for zero span mode. The EUT uplink and downlink were loop backed to each other through a selectable band pass filter and variable attenuator. The EUT uplink and downlink were tested to ensure that the presence of oscillation was detected and that the EUT output turned off within 300 mS for the Uplink and 1 second for the Downlink and remained off for 1 minute. The time was extended to capture how many times the unit attempted to restart.

Anti-Oscillation was measured for all signal paths.

Per the manufacturer, for the Restart Timing and # of Restarts test, the signal booster shuts down after the first oscillation detection and there are no restarts to be measured.

There restart test was monitored and recorded for 350 seconds to verify no restarts.

Signal Paths measured for Anti-Oscillation

Anti-Oscillation					Anti-Oscillation		
Dedicated Ports					Common Ports		
U/L					U/L		
B12	B13	B5	B4	B25	B12	B13	B5
S1 to D3	S1 to D3	S1 to D2	S1 to D1	S1 to D1	S1 to D1	S1 to D1	S1 to D1
S2 to D3	S2 to D3	S2 to D2	S2 to D1	S2 to D1	S2 to D1	S2 to D1	S2 to D1
S3 to D3	S3 to D3	S3 to D2	S3 to D1	S3 to D1	S3 to D1	S3 to D1	S3 to D1
S4 to D3	S4 to D3	S4 to D2	S4 to D1	S4 to D1	S4 to D1	S4 to D1	S4 to D1
D/L					D/L		
B12	B13	B5	B4	B25	B12	B13	B5
D3 to S1	D3 to S1	D2 to S1	D1 to S1	D1 to S1	D1 to S1	D1 to S1	D1 to S1
D3 to S2	D3 to S2	D2 to S2	D1 to S2	D1 to S2	D1 to S2	D1 to S2	D1 to S2
D3 to S3	D3 to S3	D2 to S3	D1 to S3	D1 to S3	D1 to S3	D1 to S3	D1 to S3
D3 to S4	D3 to S4	D2 to S4	D1 to S4	D1 to S4	D1 to S4	D1 to S4	D1 to S4

Test Setup

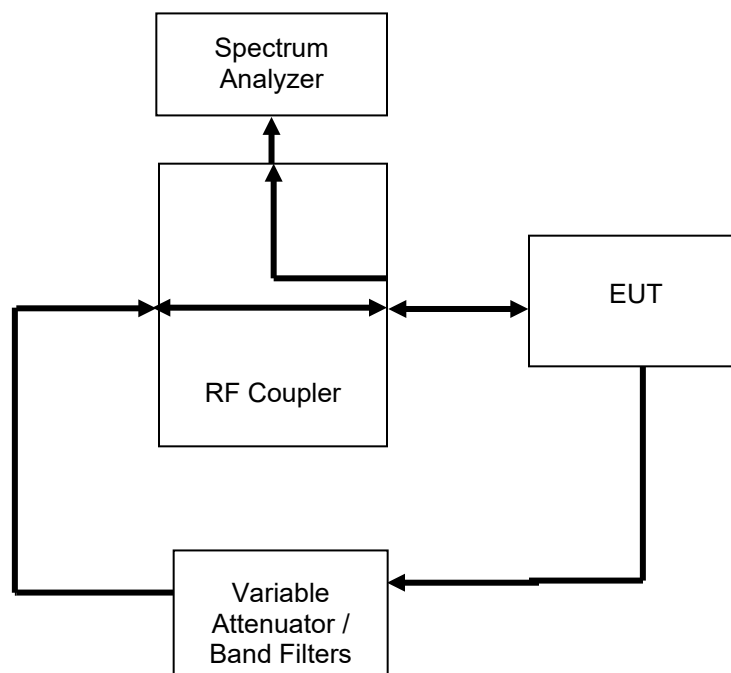

Uplink Detection Time Test Results

Server Port 1 to Dedicated Donor Port

Frequency Band (MHz)	Measured Time (mS)	Limit (mS)	Result
698 - 716	100	300	Pass
776 - 787	100	300	Pass
824 - 849	237.5	300	Pass
1710 - 1755	100	300	Pass
1850 - 1915	150	300	Pass

Uplink Detection Time

Server Port 2 to Dedicated Donor Port

Frequency Band (MHz)	Measured Time (mS)	Limit (mS)	Result
698 - 716	137.5	300	Pass
776 - 787	100	300	Pass
824 - 849	150	300	Pass
1710 - 1755	137.5	300	Pass
1850 - 1915	137.5	300	Pass

Uplink Detection Time

Server Port 3 to Dedicated Donor Port

Frequency Band (MHz)	Measured Time (mS)	Limit (mS)	Result
698 - 716	137.5	300	Pass
776 - 787	100	300	Pass
824 - 849	150	300	Pass
1710 - 1755	150	300	Pass
1850 - 1915	175	300	Pass

Uplink Detection Time

Server Port 4 to Dedicated Donor Port

Frequency Band (MHz)	Measured Time (mS)	Limit (mS)	Result
698 - 716	137.5	300	Pass
776 - 787	137.5	300	Pass
824 - 849	187.5	300	Pass
1710 - 1755	137.5	300	Pass
1850 - 1915	137.5	300	Pass

**Uplink Detection Time
Server Port 1 to Common Donor Port 1**

Frequency Band (MHz)	Measured Time (mS)	Limit (mS)	Result
698 - 716	112.5	300	Pass
776 - 787	112.5	300	Pass
824 - 849	150	300	Pass

**Uplink Detection Time
Server Port 2 to Common Donor Port 1**

Frequency Band (MHz)	Measured Time (mS)	Limit (mS)	Result
698 - 716	112.5	300	Pass
776 - 787	100	300	Pass
824 - 849	187.5	300	Pass

**Uplink Detection Time
Server Port 3 to Common Donor Port 1**

Frequency Band (MHz)	Measured Time (mS)	Limit (mS)	Result
698 - 716	137.5	300	Pass
776 - 787	100	300	Pass
824 - 849	112.5	300	Pass

**Uplink Detection Time
Server Port 4 to Common Donor Port 1**

Frequency Band (MHz)	Measured Time (mS)	Limit (mS)	Result
698 - 716	125	300	Pass
776 - 787	112.5	300	Pass
824 - 849	150	300	Pass

Downlink Detection Time Test Results

Dedicated Donor Port to Server Port 1

Frequency Band (MHz)	Measured Time (mS)	Limit (mS)	Result
728 - 746	137.5	1000	Pass
746 - 757	135	1000	Pass
869 - 894	187.5	1000	Pass
1930 - 1995	125	1000	Pass
2110 - 2155	125	1000	Pass

Downlink Detection Time Dedicated Donor Port to Server Port 2

Frequency Band (MHz)	Measured Time (mS)	Limit (mS)	Result
728 - 746	137.5	1000	Pass
746 - 757	137.5	1000	Pass
869 - 894	187.5	1000	Pass
1930 - 1995	125	1000	Pass
2110 - 2155	125	1000	Pass

Downlink Detection Time Dedicated Donor Port to Server Port 3

Frequency Band (MHz)	Measured Time (mS)	Limit (mS)	Result
728 - 746	137.5	1000	Pass
746 - 757	137.5	1000	Pass
869 - 894	187.5	1000	Pass
1930 - 1995	125	1000	Pass
2110 - 2155	125	1000	Pass

Downlink Detection Time Dedicated Donor Port to Server Port 4

Frequency Band (MHz)	Measured Time (mS)	Limit (mS)	Result
728 - 746	150	1000	Pass
746 - 757	137.5	1000	Pass
869 - 894	187.5	1000	Pass
1930 - 1995	137.5	1000	Pass
2110 - 2155	100	1000	Pass

**Downlink Detection Time
Common Donor Port 1 to Server Port 1**

Frequency Band (MHz)	Measured Time (mS)	Limit (mS)	Result
728 - 746	100	1000	Pass
746 - 757	150	1000	Pass
869 - 894	187.5	1000	Pass

**Downlink Detection Time
Common Donor Port 1 to Server Port 2**

Frequency Band (MHz)	Measured Time (mS)	Limit (mS)	Result
728 - 746	137.5	1000	Pass
746 - 757	137.5	1000	Pass
869 - 894	187.5	1000	Pass

**Downlink Detection Time
Common Donor Port 1 to Server Port 3**

Frequency Band (MHz)	Measured Time (mS)	Limit (mS)	Result
728 - 746	150	1000	Pass
746 - 757	137.5	1000	Pass
869 - 894	187.5	1000	Pass

**Downlink Detection Time
Common Donor Port 1 to Server Port 4**

Frequency Band (MHz)	Measured Time (mS)	Limit (mS)	Result
728 - 746	150	1000	Pass
746 - 757	137.5	1000	Pass
869 - 894	187.5	1000	Pass

Note: For all uplink and downlink signal paths

Per the manufacturer, for the Restart Timing and # of Restarts test, the signal booster shuts down after the first oscillation detection and there are no restarts to be measured.

The restart test was monitored and recorded for 350 seconds to verify no restarts.

Uplink Restart Time Test Results

Frequency Band (MHz)	Measured Time (S)	Limit (S)	Result
698 - 716	No Restarts	≥60	Pass
776 - 787	No Restarts	≥60	Pass
824 - 849	No Restarts	≥60	Pass
1710 - 1755	No Restarts	≥60	Pass
1850 - 1915	No Restarts	≥60	Pass

Downlink Restart Time Test Results

Frequency Band (MHz)	Measured Time (S)	Limit (S)	Result
728 - 746	No Restarts	≥60	Pass
746 - 757	No Restarts	≥60	Pass
869 - 894	No Restarts	≥60	Pass
1930 - 1995	No Restarts	≥60	Pass
2110 - 2155	No Restarts	≥60	Pass

Uplink Restart Count Test Results

Frequency Band (MHz)	Restarts	Limit	Result
698 - 716	No Restarts	≤5	Pass
776 - 787	No Restarts	≤5	Pass
824 - 849	No Restarts	≤5	Pass
1710 - 1755	No Restarts	≤5	Pass
1850 - 1915	No Restarts	≤5	Pass

Downlink Restart Count Test Results

Frequency Band (MHz)	Restarts	Limit	Result
728 - 746	No Restarts	≤5	Pass
746 - 757	No Restarts	≤5	Pass
869 - 894	No Restarts	≤5	Pass
1930 - 1995	No Restarts	≤5	Pass
2110 - 2155	No Restarts	≤5	Pass

Annex I Anti-Oscillation

Refer to Annex I for Anti-Oscillation Plots

Oscillation Mitigation

Engineer: Greg Corbin

Test Date: 5/24/2019

Test Procedure

The EUT was connected as shown per KDB 935210 D03. The EUT was verified to shut down in the presence of an oscillation.

The total attenuation from output to input was set +5 dB higher than the gain for the band being tested.

For EUT's that do not shutdown, the peak oscillation was measured and the variable attenuator was reduced in 1 dB increments until the booster shuts off.

The frequency and amplitude of the highest oscillation and the lowest level in the valley next to the oscillation was recorded for each 1 dB step as required per the KDB.

For oscillations that exceeded the 12 dB limit, the time required for the booster to mitigate the oscillation to less than 12 dB was recorded.

If the booster mitigated the oscillation within the 300 second time limit, the time required to mitigate the oscillation was recorded along with the final level of the oscillation after mitigation.

Oscillation Mitigation was measured for all signal paths.

Note: In all cases the booster mitigated the oscillation to less than 12 dB before the 300 second limit.

Signal Paths measured for Oscillation Mitigation

Oscillation Mitigation					Oscillation Mitigation		
Dedicated Ports					Common Ports		
U/L					U/L		
B12	B13	B5	B4	B25	B12	B13	B5
S1 to D3	S1 to D3	S1 to D2	S1 to D1	S1 to D1	S1 to D1	S1 to D1	S1 to D1
S2 to D3	S2 to D3	S2 to D2	S2 to D1	S2 to D1	S2 to D1	S2 to D1	S2 to D1
S3 to D3	S3 to D3	S3 to D2	S3 to D1	S3 to D1	S3 to D1	S3 to D1	S3 to D1
S4 to D3	S4 to D3	S4 to D2	S4 to D1	S4 to D1	S4 to D1	S4 to D1	S4 to D1
D/L					D/L		
B12	B13	B5	B4	B25	B12	B13	B5
D3 to S1	D3 to S1	D2 to S1	D1 to S1	D1 to S1	D1 to S1	D1 to S1	D1 to S1
D3 to S2	D3 to S2	D2 to S2	D1 to S2	D1 to S2	D1 to S2	D1 to S2	D1 to S2
D3 to S3	D3 to S3	D2 to S3	D1 to S3	D1 to S3	D1 to S3	D1 to S3	D1 to S3
D3 to S4	D3 to S4	D2 to S4	D1 to S4	D1 to S4	D1 to S4	D1 to S4	D1 to S4

Test Setup

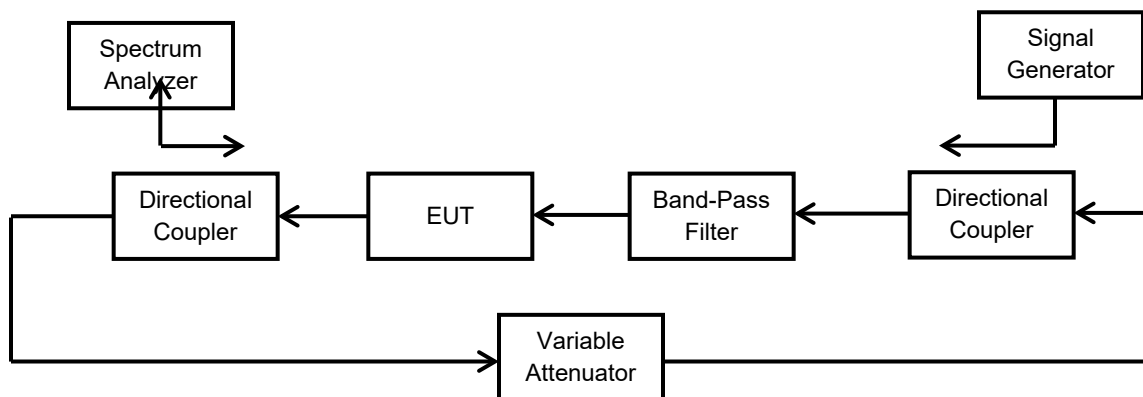

Uplink Oscillation Mitigation Test Data – Dedicated Ports

Oscillation Mitigation – Uplink Server Port 1 to Dedicated Port 3									
Band	698 – 716 MHz								
Test Signal Type	CDMA								
Variable Attenuator Setting	Oscillations and Power Levels				Margin	Limit	Time to Mitigate Oscillation	Mitigation Time Limit	Pass / Fail
	Freq.	Level	Freq.	Level					
dB	MHz	dBm	MHz	dBm	dB	dB	sec	sec	
+5	712.227	-61.5	714.24	-69.1	7.6	<12	N/A	< 300	P
+4	712.227	-60.3	714.24	-71.1	10.8	<12	N/A	< 300	P
+3	712.227	-61.5	714.24	-73.2	11.7	<12	N/A	< 300	P
+2	712.227	-60.8	714.24	-73.2	12.4	<12	73	< 300	P
+1	712.227	-65.8	714.24	-75.2	9.4	<12	N/A	< 300	P
+0	712.227	-65.2	714.24	-75.6	10.4	<12	N/A	< 300	P
-1	712.227	-64.7	714.24	-76.1	11.4	<12	N/A	< 300	P
-2	712.227	-63.4	714.24	-76.9	13.5	<12	68	< 300	P
-3	712.227	-68	714.24	-78.6	10.6	<12	N/A	< 300	P
-4	712.227	-67.7	714.24	-77.5	9.8	<12	N/A	< 300	P
-5	712.227	-65.9	714.24	-78.9	13	<12	78	< 300	P

Oscillation Mitigation – Uplink Server Port 1 to Dedicated Port 3									
Band	776 – 787 MHz								
Test Signal Type	CDMA								
Variable Attenuator Setting	Oscillations and Power Levels				Margin	Limit	Time to Mitigate Oscillation	Mitigation Time Limit	Pass / Fail
	Freq.	Level	Freq.	Level					
dB	MHz	dBm	MHz	dBm	dB	dB	sec	sec	
+5	780.04	-54.5	781.54	-65.5	11	<12	N/A	< 300	P
+4	780.04	-53.1	781.54	-66	12.9	<12	131	< 300	P
+3	780.04	-57.2	781.54	-67.3	10.1	<12	N/A	< 300	P
+2	780.04	-55.4	781.54	-68.4	13	<12	114	< 300	P
+1	780.04	-58.4	781.54	-69.7	11.3	<12	N/A	< 300	P
+0	780.04	-57.6	781.54	-70.3	12.7	<12	220	< 300	P
-1	780.04	-61.8	781.54	-72.1	10.3	<12	N/A	< 300	P
-2	780.04	-62.2	781.54	-72.7	10.5	<12	N/A	< 300	P
-3	780.04	-61.6	781.54	-72.9	11.3	<12	N/A	< 300	P
-4	780.04	-60.1	781.54	-73.8	13.7	<12	110	< 300	P
-5	780.04	-65.4	781.54	-75.6	10.2	<12	N/A	< 300	P

Oscillation Mitigation – Uplink Server Port 1 to Dedicated Port 2									
Band	824 - 849 MHz								
Test Signal Type	CDMA								
Variable Attenuator Setting	Oscillations and Power Levels				Margin	Limit	Time to Mitigate Oscillation	Mitigation Time Limit	Pass / Fail
	Freq.	Level	Freq.	Level					
dB	MHz	dBm	MHz	dBm	dB	dB	sec	sec	
+5	835.83	-53.1	838.4	-66.5	13.4	<12	135	< 300	P
+4	835.83	-58.4	838.4	-68.4	10	<12	N/A	< 300	P
+3	835.83	-56.8	838.4	-68.5	11.7	<12	N/A	< 300	P
+2	835.83	-55.3	838.4	-69.2	13.9	<12	92	< 300	P
+1	835.83	-61	838.4	-71.7	10.7	<12	N/A	< 300	P
+0	835.83	-60.4	838.4	-71.7	11.3	<12	N/A	< 300	P
-1	835.83	-58.8	838.4	-71.9	13.1	<12	206	< 300	P
-2	835.83	-65.8	838.4	-75.2	9.4	<12	N/A	< 300	P
-3	835.83	-64.4	838.4	-74.5	10.1	<12	N/A	< 300	P
-4	835.83	-63.7	838.4	-75	11.3	<12	N/A	< 300	P
-5	835.83	-62.2	838.4	-75.3	13.1	<12	78	< 300	P

Oscillation Mitigation – Uplink Server Port 1 to Dedicated Port 1									
Band	1710 - 1755 MHz								
Test Signal Type	CDMA								
Variable Attenuator Setting	Oscillations and Power Levels				Margin	Limit	Time to Mitigate Oscillation	Mitigation Time Limit	Pass / Fail
	Freq.	Level	Freq.	Level					
dB	MHz	dBm	MHz	dBm	dB	dB	sec	sec	
+5	1727.06	-49.8	1722.26	-60.1	10.3	<12	N/A	< 300	P
+4	1727.06	-46.8	1722.26	-60.7	13.9	<12	110	< 300	P
+3	1727.06	-51.9	1722.26	-61.7	9.8	<12	N/A	< 300	P
+2	1727.06	-51.6	1722.26	-63.1	11.5	<12	N/A	< 300	P
+1	1727.06	-49.5	1722.26	-63.3	13.8	<12	90	< 300	P
+0	1727.06	-55.8	1722.26	-65.9	10.1	<12	N/A	< 300	P
-1	1727.06	-55.1	1722.26	-65.6	10.5	<12	N/A	< 300	P
-2	1727.06	-51.9	1722.26	-66.1	14.2	<12	210	< 300	P
-3	1727.06	-57.5	1722.26	-67.8	10.3	<12	N/A	< 300	P
-4	1727.06	-55.9	1722.26	-68.9	13	<12	128	< 300	P
-5	1727.06	-60.8	1722.26	-70.7	9.9	<12	N/A	< 300	P

Oscillation Mitigation – Uplink Server Port 1 to Dedicated Port 1									
Band	1850 - 1915 MHz								
Test Signal Type	CDMA								
Variable Attenuator Setting	Oscillations and Power Levels				Margin	Limit	Time to Mitigate Oscillation	Mitigation Time Limit	Pass / Fail
	Freq.	Level	Freq.	Level					
dB	MHz	dBm	MHz	dBm	dB	dB	sec	sec	
+5	1868.22	-48.1	1872.67	-56.8	8.7	<12	N/A	< 300	P
+4	1868.22	-46	1872.67	-59.3	13.3	<12	25	< 300	P
+3	1868.22	-49.8	1872.67	-60.9	11.1	<12	N/A	< 300	P
+2	1868.22	-49.6	1872.67	-60.5	10.9	<12	N/A	< 300	P
+1	1868.22	-47.5	1872.67	-61.7	14.2	<12	76	< 300	P
+0	1868.22	-53	1872.67	-63.6	10.6	<12	N/A	< 300	P
-1	1868.22	-51.3	1872.67	-64.3	13	<12	237	< 300	P
-2	1868.22	-54.8	1872.67	-65.2	10.4	<12	N/A	< 300	P
-3	1868.22	-53.3	1872.67	-64.6	11.3	<12	N/A	< 300	P
-4	1868.22	-51	1872.67	-66.9	15.9	<12	110	< 300	P
-5	1868.22	-59	1872.67	-69.3	10.3	<12	N/A	< 300	P

Oscillation Mitigation – Uplink Server Port 2 to Dedicated Port 3									
Band	698 – 716 MHz								
Test Signal Type	CDMA								
Variable Attenuator Setting	Oscillations and Power Levels				Margin	Limit	Time to Mitigate Oscillation	Mitigation Time Limit	Pass / Fail
	Freq.	Level	Freq.	Level					
dB	MHz	dBm	MHz	dBm	dB	dB	sec	sec	
+5	709.192	-60	706.971	-69.1	9.1	<12	N/A	< 300	P
+4	709.192	-59	706.971	-69.9	10.9	<12	N/A	< 300	P
+3	709.192	-57.4	706.971	-69.9	12.5	<12	45	< 300	P
+2	709.192	-62.2	706.971	-71.2	9	<12	N/A	< 300	P
+1	709.192	-60.5	706.971	-71.3	10.8	<12	N/A	< 300	P
+0	709.192	-61.9	706.971	-72.6	10.7	<12	N/A	< 300	P
-1	709.192	-61.6	706.971	-73.1	11.5	<12	N/A	< 300	P
-2	709.192	-59.8	706.971	-73.4	13.6	<12	104	< 300	P
-3	709.192	-66.9	706.971	-75.1	8.2	<12	N/A	< 300	P
-4	709.192	-65.1	706.971	-76.7	11.6	<12	N/A	< 300	P
-5	709.192	-63.3	706.971	-76.4	13.1	<12	115	< 300	P

Oscillation Mitigation – Uplink Server Port 2 to Dedicated Port 3									
Band	776 – 787 MHz								
Test Signal Type	CDMA								
Variable Attenuator Setting	Oscillations and Power Levels				Margin	Limit	Time to Mitigate Oscillation	Mitigation Time Limit	Pass / Fail
	Freq.	Level	Freq.	Level					
dB	MHz	dBm	MHz	dBm	dB	dB	sec	sec	
+5	778.02	-52	779.39	-65.1	13.1	<12	152	< 300	P
+4	778.02	-58.8	779.39	-67.8	9	<12	N/A	< 300	P
+3	778.02	-57.6	779.39	-68	10.4	<12	N/A	< 300	P
+2	778.02	-55.6	779.39	-68.8	13.2	<12	105	< 300	P
+1	778.02	-64.4	779.39	-71.7	7.3	<12	N/A	< 300	P
+0	778.02	-63.2	779.39	-71.6	8.4	<12	N/A	< 300	P
-1	778.02	-62.6	779.39	-71.8	9.2	<12	N/A	< 300	P
-2	778.02	-61.2	779.39	-72.3	11.1	<12	N/A	< 300	P
-3	778.02	-62.2	779.39	-75	12.8	<12	68	< 300	P
-4	778.02	-60.9	779.39	-75.8	14.9	<12	44	< 300	P
-5	EUT Shutdown								P

Oscillation Mitigation – Uplink Server Port 2 to Dedicated Port 2									
Band	824 - 849 MHz								
Test Signal Type	CDMA								
Variable Attenuator Setting	Oscillations and Power Levels				Margin	Limit	Time to Mitigate Oscillation	Mitigation Time Limit	Pass / Fail
	Freq.	Level	Freq.	Level					
dB	MHz	dBm	MHz	dBm	dB	dB	sec	sec	
+5	837.44	-55.4	840	-66.4	11	<12	N/A	< 300	P
+4	837.44	-51.9	840	-66.6	14.7	<12	31	< 300	P
+3	837.44	-57.8	840	-67.2	9.4	<12	N/A	< 300	P
+2	837.44	-55.1	840	-68.4	13.3	<12	129	< 300	P
+1	837.44	-59.7	840	-69.7	10	<12	N/A	< 300	P
+0	837.44	-58.7	840	-69.7	11	<12	N/A	< 300	P
-1	837.44	-57.3	840	-70.3	13	<12	202	< 300	P
-2	837.44	-55.2	840	-62.3	7.1	<12	N/A	< 300	P
-3	837.44	-65.7	840	-74.2	8.5	<12	N/A	< 300	P
-4	837.44	-65.1	840	-75.7	10.6	<12	N/A	< 300	P
-5	837.44	-64.3	840	-75.4	11.1	<12	N/A	< 300	P

Oscillation Mitigation – Uplink Server Port 2 to Dedicated Port 1									
Band	1710 - 1755 MHz								
Test Signal Type	CDMA								
Variable Attenuator Setting	Oscillations and Power Levels				Margin	Limit	Time to Mitigate Oscillation	Mitigation Time Limit	Pass / Fail
	Freq.	Level	Freq.	Level					
dB	MHz	dBm	MHz	dBm	dB	dB	sec	sec	
+5	1732.77	-47.9	1737.92	-59	11.1	<12	N/A	< 300	P
+4	1732.77	-47	1737.92	-59.9	12.9	<12	100	< 300	P
+3	1732.77	-51.7	1737.92	-61.3	9.6	<12	N/A	< 300	P
+2	1732.77	-49.6	1737.92	-60.1	10.5	<12	N/A	< 300	P
+1	1732.77	-49.4	1737.92	-62.8	13.4	<12	82	< 300	P
+0	1732.77	-53.5	1737.92	-63.5	10	<12	N/A	< 300	P
-1	1732.77	-51.6	1737.92	-63	11.4	<12	N/A	< 300	P
-2	1732.77	-50.3	1737.92	-64.9	14.6	<12	221	< 300	P
-3	1732.77	-56.2	1737.92	-66.6	10.4	<12	N/A	< 300	P
-4	1732.77	-55.5	1737.92	-67	11.5	<12	N/A	< 300	P
-5	1732.77	-60.4	1737.92	-70.6	10.2	<12	N/A	< 300	P

Oscillation Mitigation – Uplink Server Port 2 to Dedicated Port 1									
Band	1850 - 1915 MHz								
Test Signal Type	CDMA								
Variable Attenuator Setting	Oscillations and Power Levels				Margin	Limit	Time to Mitigate Oscillation	Mitigation Time Limit	Pass / Fail
	Freq.	Level	Freq.	Level					
dB	MHz	dBm	MHz	dBm	dB	dB	sec	sec	
+5	1865.59	-47	1870.02	-58.3	11.3	<12	N/A	< 300	P
+4	1865.59	-45.7	1870.02	-58.4	12.7	<12	110	< 300	P
+3	1865.59	-49.2	1870.02	-60.8	11.6	<12	N/A	< 300	P
+2	1865.59	-47.1	1870.02	-60.7	13.6	<12	106	< 300	P
+1	1865.59	-51.3	1870.02	-62.5	11.2	<12	N/A	< 300	P
+0	1865.59	-50.4	1870.02	-63.7	13.3	<12	253	< 300	P
-1	1865.59	-54	1870.02	-63.9	9.9	<12	N/A	< 300	P
-2	1865.59	-52.8	1870.02	-65.6	12.8	<12	142	< 300	P
-3	1865.59	-56.2	1870.02	-66.1	9.9	<12	N/A	< 300	P
-4	1865.59	-52.9	1870.02	-67	14.1	<12	113	< 300	P
-5	1865.59	-59.8	1870.02	-70.1	10.3	<12	N/A	< 300	P

Oscillation Mitigation – Uplink Server Port 3 to Dedicated Port 3									
Band	698 – 716 MHz								
Test Signal Type	CDMA								
Variable Attenuator Setting	Oscillations and Power Levels				Margin	Limit	Time to Mitigate Oscillation	Mitigation Time Limit	Pass / Fail
	Freq.	Level	Freq.	Level					
dB	MHz	dBm	MHz	dBm	dB	dB	sec	sec	
+5	709.087	-59.6	706.971	-68.9	9.3	<12	N/A	< 300	P
+4	709.087	-58.6	706.971	-70	11.4	<12	N/A	< 300	P
+3	709.087	-57.7	706.971	-70.5	12.8	<12	45	< 300	P
+2	709.087	-60.2	706.971	-71.4	11.2	<12	N/A	< 300	P
+1	709.087	-58.9	706.971	-71.6	12.7	<12	121	< 300	P
+0	709.087	-61.7	706.971	-73.4	11.7	<12	N/A	< 300	P
-1	709.087	-60.8	706.971	-73.8	13	<12	220	< 300	P
-2	709.087	-64.6	706.971	-75.5	10.9	<12	N/A	< 300	P
-3	709.087	-63.7	706.971	-76.2	12.5	<12	136	< 300	P
-4	709.087	-66.9	706.971	-76.8	9.9	<12	N/A	< 300	P
-5	709.087	-65.6	706.971	-76.5	10.9	<12	N/A	< 300	P

Oscillation Mitigation – Uplink Server Port 3 to Dedicated Port 3									
Band	776 – 787 MHz								
Test Signal Type	CDMA								
Variable Attenuator Setting	Oscillations and Power Levels				Margin	Limit	Time to Mitigate Oscillation	Mitigation Time Limit	Pass / Fail
	Freq.	Level	Freq.	Level					
dB	MHz	dBm	MHz	dBm	dB	dB	sec	sec	
+5	779.77	-55	781.354	-66.2	11.2	<12	N/A	< 300	P
+4	779.77	-52.6	781.354	-65.6	13	<12	135	< 300	P
+3	779.77	-56.6	781.354	-68	11.4	<12	N/A	< 300	P
+2	779.77	-55.1	781.354	-67.7	12.6	<12	210	< 300	P
+1	779.77	-59.3	781.354	-68.6	9.3	<12	N/A	< 300	P
+0	779.77	-57.5	781.354	-70.7	13.2	<12	150	< 300	P
-1	779.77	-61.5	781.354	-71.5	10	<12	N/A	< 300	P
-2	779.77	-59.6	781.354	-72.5	12.9	<12	142	< 300	P
-3	779.77	-63.4	781.354	-74.3	10.9	<12	N/A	< 300	P
-4	779.77	-62.2	781.354	-73.7	11.5	<12	N/A	< 300	P
-5	779.77	-59.3	781.354	-73.9	14.6	<12	91	< 300	P

Oscillation Mitigation – Uplink Server Port 3 to Dedicated Port 2									
Band	824 - 849 MHz								
Test Signal Type	CDMA								
Variable Attenuator Setting	Oscillations and Power Levels				Margin	Limit	Time to Mitigate Oscillation	Mitigation Time Limit	Pass / Fail
	Freq.	Level	Freq.	Level					
dB	MHz	dBm	MHz	dBm	dB	dB	sec	sec	
+5	837.43	-53.6	839.73	-65.2	11.6	<12	N/A	< 300	P
+4	837.43	-53.5	839.73	-66.6	13.1	<12	155	< 300	P
+3	837.43	-57.2	839.73	-68.5	11.3	<12	N/A	< 300	P
+2	837.43	-55.5	839.73	-68.6	13.1	<12	155	< 300	P
+1	837.43	-62.3	839.73	-71.9	9.6	<12	N/A	< 300	P
+0	837.43	-60.5	839.73	-70.4	9.9	<12	N/A	< 300	P
-1	837.43	-59.5	839.73	-70.8	11.3	<12	N/A	< 300	P
-2	837.43	-58.3	839.73	-72.3	14	<12	148	< 300	P
-3	837.43	-64.5	839.73	-73.2	8.7	<12	N/A	< 300	P
-4	837.43	-62.5	839.73	-75.2	12.7	<12	195	< 300	P
-5	837.43	-66.3	839.73	-76.6	10.3	<12	N/A	< 300	P

Oscillation Mitigation – Uplink Server Port 3 to Dedicated Port 1									
Band	1710 - 1755 MHz								
Test Signal Type	CDMA								
Variable Attenuator Setting	Oscillations and Power Levels				Margin	Limit	Time to Mitigate Oscillation	Mitigation Time Limit	Pass / Fail
	Freq.	Level	Freq.	Level					
dB	MHz	dBm	MHz	dBm	dB	dB	sec	sec	
+5	1728.73	-47.5	1723.87	-58.6	11.1	<12	N/A	< 300	P
+4	1728.73	-45.7	1723.87	-60.5	14.8	<12	101	< 300	P
+3	1728.73	-53	1723.87	-62.3	9.3	<12	N/A	< 300	P
+2	1728.73	-52.2	1723.87	-63.3	11.1	<12	N/A	< 300	P
+1	1728.73	-50.3	1723.87	-63.1	12.8	<12	121	< 300	P
+0	1728.73	-55	1723.87	-67.2	12.2	<12	N/A	< 300	P
-1	1728.73	-54.9	1723.87	-66.4	11.5	<12	N/A	< 300	P
-2	1728.73	-53.7	1723.87	-66.8	13.1	<12	230	< 300	P
-3	1728.73	-60.2	1723.87	-68.4	8.2	<12	N/A	< 300	P
-4	1728.73	-59.2	1723.87	-67.3	8.1	<12	N/A	< 300	P
-5	1728.73	-58.7	1723.87	-69.8	11.1	<12	N/A	< 300	P

Oscillation Mitigation – Uplink Server Port 3 to Dedicated Port 1									
Band	1850 - 1915 MHz								
Test Signal Type	CDMA								
Variable Attenuator Setting	Oscillations and Power Levels				Margin	Limit	Time to Mitigate Oscillation	Mitigation Time Limit	Pass / Fail
	Freq.	Level	Freq.	Level					
dB	MHz	dBm	MHz	dBm	dB	dB	sec	sec	
+5	1866.76	-46.5	1871.46	-57.7	11.2	<12	N/A	< 300	P
+4	1866.76	-44.4	1871.46	-58.3	13.9	<12	60	< 300	P
+3	1866.76	-49.9	1871.46	-60.1	10.2	<12	N/A	< 300	P
+2	1866.76	-47.6	1871.46	-60.5	12.9	<12	131	< 300	P
+1	1866.76	-53.9	1871.46	-63	9.1	<12	N/A	< 300	P
+0	1866.76	-52.1	1871.46	-63.8	11.7	<12	N/A	< 300	P
-1	1866.76	-49.9	1871.46	-64.4	14.5	<12	220	< 300	P
-2	1866.76	-55.9	1871.46	-66.2	10.3	<12	N/A	< 300	P
-3	1866.76	-54.5	1871.46	-65.9	11.4	<12	N/A	< 300	P
-4	1866.76	-50.6	1871.46	-66.1	15.5	<12	109	< 300	P
-5	1866.76	-58.5	1871.46	-69.3	10.8	<12	N/A	< 300	P

Oscillation Mitigation – Uplink Server Port 4 to Dedicated Port 3									
Band	698 – 716 MHz								
Test Signal Type	CDMA								
Variable Attenuator Setting	Oscillations and Power Levels				Margin	Limit	Time to Mitigate Oscillation	Mitigation Time Limit	Pass / Fail
	Freq.	Level	Freq.	Level					
dB	MHz	dBm	MHz	dBm	dB	dB	sec	sec	
+5	707.965	-60.3	705.626	-69	8.7	<12	N/A	< 300	P
+4	707.965	-59.8	705.626	-69.5	9.7	<12	N/A	< 300	P
+3	707.965	-58.8	705.626	-69	10.2	<12	N/A	< 300	P
+2	707.965	-57.8	705.626	-70.4	12.6	<12	32	< 300	P
+1	707.965	-61.9	705.626	-72.2	10.3	<12	N/A	< 300	P
+0	707.965	-61.2	705.626	-72.4	11.2	<12	N/A	< 300	P
-1	707.965	-59	705.626	-73.7	14.7	<12	106	< 300	P
-2	707.965	-64.7	705.626	-75.1	10.4	<12	N/A	< 300	P
-3	707.965	-63.4	705.626	-76.2	12.8	<12	52	< 300	P
-4	707.965	-67.1	705.626	-76.8	9.7	<12	N/A	< 300	P
-5	707.965	-67.1	705.626	-77.6	10.5	<12	N/A	< 300	P

Oscillation Mitigation – Uplink Server Port 4 to Dedicated Port 3									
Band	776 – 787 MHz								
Test Signal Type	CDMA								
Variable Attenuator Setting	Oscillations and Power Levels				Margin	Limit	Time to Mitigate Oscillation	Mitigation Time Limit	Pass / Fail
	Freq.	Level	Freq.	Level					
dB	MHz	dBm	MHz	dBm	dB	dB	sec	sec	
+5	779.716	-55.9	781.354	-64.8	8.9	<12	N/A	< 300	P
+4	779.716	-54.8	781.354	-66.1	11.3	<12	N/A	< 300	P
+3	779.716	-52.3	781.354	-66.7	14.4	<12	129	< 300	P
+2	779.716	-58.2	781.354	-68.7	10.5	<12	N/A	< 300	P
+1	779.716	-55.6	781.354	-69.1	13.5	<12	136	< 300	P
+0	779.716	-60.6	781.354	-69.7	9.1	<12	N/A	< 300	P
-1	779.716	-58.9	781.354	-70.3	11.4	<12	N/A	< 300	P
-2	779.716	-53.4	781.354	-67.3	13.89	<12	64	< 300	P
-3	779.716	-63.3	781.354	-74.5	11.2	<12	N/A	< 300	P
-4	779.716	-61.7	781.354	-74.1	12.4	<12	140	< 300	P
-5	779.716	-64.5	781.354	-76.2	11.7	<12	N/A	< 300	P

Oscillation Mitigation – Uplink Server Port 4 to Dedicated Port 2									
Band	824 - 849 MHz								
Test Signal Type	CDMA								
Variable Attenuator Setting	Oscillations and Power Levels				Margin	Limit	Time to Mitigate Oscillation	Mitigation Time Limit	Pass / Fail
	Freq.	Level	Freq.	Level					
dB	MHz	dBm	MHz	dBm	dB	dB	sec	sec	
+5	836.06	-54.8	838.31	-65.6	10.8	<12	N/A	< 300	P
+4	836.06	-53.7	838.31	-66.6	12.9	<12	104	< 300	P
+3	836.06	-58.2	838.31	-67.2	9	<12	N/A	< 300	P
+2	836.06	-56.7	838.31	-67.8	11.1	<12	N/A	< 300	P
+1	836.06	-43.1	838.31	-67.2	24.1	<12	128	< 300	P
+0	836.06	-60.7	838.31	-71.2	10.5	<12	N/A	< 300	P
-1	836.06	-60.1	838.31	-71.3	11.2	<12	N/A	< 300	P
-2	836.06	-58.2	838.31	-71.4	13.2	<12	116	< 300	P
-3	836.06	-64.2	838.31	-73.9	9.7	<12	N/A	< 300	P
-4	836.06	-63.5	838.31	-74.3	10.8	<12	N/A	< 300	P
-5	836.06	-60.7	838.31	-75.2	14.5	<12	212	< 300	P

Oscillation Mitigation – Uplink Server Port 4 to Dedicated Port 1									
Band	1710 - 1755 MHz								
Test Signal Type	CDMA								
Variable Attenuator Setting	Oscillations and Power Levels				Margin	Limit	Time to Mitigate Oscillation	Mitigation Time Limit	Pass / Fail
	Freq.	Level	Freq.	Level					
dB	MHz	dBm	MHz	dBm	dB	dB	sec	sec	
+5	1732.82	-48.9	1727.73	-59.1	10.2	<12	N/A	< 300	P
+4	1732.82	-47.5	1727.73	-59.4	11.9	<12	N/A	< 300	P
+3	1732.82	-45.8	1727.73	-60.2	14.4	<12	55	< 300	P
+2	1732.82	-50.5	1727.73	-61.5	11	<12	N/A	< 300	P
+1	1732.82	-49.4	1727.73	-63.7	14.3	<12	130	< 300	P
+0	1732.82	-53.6	1727.73	-63.8	10.2	<12	N/A	< 300	P
-1	1732.82	-52.8	1727.73	-64.3	11.5	<12	N/A	< 300	P
-2	1732.82	-51.9	1727.73	-65.8	13.9	<12	224	< 300	P
-3	1732.82	-56.4	1727.73	-67.7	11.3	<12	N/A	< 300	P
-4	1732.82	-53.5	1727.73	-66.8	13.3	<12	182	< 300	P
-5	1732.82	-59.2	1727.73	-69.3	10.1	<12	N/A	< 300	P

Oscillation Mitigation – Uplink Server Port 4 to Dedicated Port 1									
Band	1850 - 1915 MHz								
Test Signal Type	CDMA								
Variable Attenuator Setting	Oscillations and Power Levels				Margin	Limit	Time to Mitigate Oscillation	Mitigation Time Limit	Pass / Fail
	Freq.	Level	Freq.	Level					
dB	MHz	dBm	MHz	dBm	dB	dB	sec	sec	
+5	1869.59	-48	1873.96	-58.8	10.8	<12	N/A	< 300	P
+4	1869.59	-47.5	1873.96	-59.8	12.3	<12	31	< 300	P
+3	1869.59	-51.1	1873.96	-61.6	10.5	<12	N/A	< 300	P
+2	1869.59	-50	1873.96	-61.2	11.2	<12	N/A	< 300	P
+1	1869.59	-48.5	1873.96	-62.1	13.6	<12	91	< 300	P
+0	1869.59	-53.8	1873.96	-63.3	9.5	<12	N/A	< 300	P
-1	1869.59	-53.8	1873.96	-63.9	10.1	<12	N/A	< 300	P
-2	1869.59	-51.2	1873.96	-65.3	14.1	<12	217	< 300	P
-3	1869.59	-56.9	1873.96	-66.5	9.6	<12	N/A	< 300	P
-4	1869.59	-54.9	1873.96	-68.3	13.4	<12	117	< 300	P
-5	1869.59	-59.6	1873.96	-69.2	9.6	<12	N/A	< 300	P

Uplink Oscillation Mitigation Test Data – Common Port

Oscillation Mitigation – Uplink Server Port 1 to Common Port 1									
Band	698 – 716 MHz								
Test Signal Type	CDMA								
Variable Attenuator Setting	Oscillations and Power Levels				Margin	Limit	Time to Mitigate Oscillation	Mitigation Time Limit	Pass / Fail
	Freq.	Level	Freq.	Level					
dB	MHz	dBm	MHz	dBm	dB	dB	sec	sec	
+5	708.14	-60.3	705.88	-69.4	9.1	<12	N/A	< 300	P
+4	708.14	-59.4	705.88	-69.8	10.4	<12	N/A	< 300	P
+3	708.14	-59	705.88	-69.9	10.9	<12	N/A	< 300	P
+2	708.14	-60.6	705.88	-72.2	11.6	<12	N/A	< 300	P
+1	708.14	-60.7	705.88	-72.2	11.5	<12	N/A	< 300	P
+0	708.14	-58.4	705.88	-72.9	14.5	<12	58	< 300	P
-1	708.14	-63.7	705.88	-73.8	10.1	<12	N/A	< 300	P
-2	708.14	-62.1	705.88	-75.3	13.2	<12	242	< 300	P
-3	708.14	-64.7	705.88	-75.8	11.1	<12	N/A	< 300	P
-4	708.14	-63.7	705.88	-77.2	13.5	<12	141	< 300	P
-5	708.14	-67.7	705.88	-78.6	10.9	<12	N/A	< 300	P

Oscillation Mitigation – Uplink Server Port 1 to Common Port 1									
Band	776 – 787 MHz								
Test Signal Type	CDMA								
Variable Attenuator Setting	Oscillations and Power Levels				Margin	Limit	Time to Mitigate Oscillation	Mitigation Time Limit	Pass / Fail
	Freq.	Level	Freq.	Level					
dB	MHz	dBm	MHz	dBm	dB	dB	sec	sec	
+5	778.49	-56.1	777.23	-66.2	10.1	<12	N/A	< 300	P
+4	778.49	-55.8	777.23	-66.9	11.1	<12	N/A	< 300	P
+3	778.49	-53.7	777.23	-67.2	13.5	<12	105	< 300	P
+2	778.49	-59.1	777.23	-69.1	10	<12	N/A	< 300	P
+1	778.49	-58.1	777.23	-69.4	11.3	<12	N/A	< 300	P
+0	778.49	-57.7	777.23	-70.7	13	<12	131	< 300	P
-1	778.49	-63.1	777.23	-72.7	9.6	<12	N/A	< 300	P
-2	778.49	-62.1	777.23	-72.6	10.5	<12	N/A	< 300	P
-3	778.49	-61.3	777.23	-74.5	13.2	<12	102	< 300	P
-4	778.49	-64.5	777.23	-75.1	10.6	<12	N/A	< 300	P
-5	778.49	-62.8	777.23	-74.6	11.8	<12	N/A	< 300	P

Oscillation Mitigation – Uplink Server Port 1 to Common Port 1									
Band	824 - 849 MHz								
Test Signal Type	CDMA								
Variable Attenuator Setting	Oscillations and Power Levels				Margin	Limit	Time to Mitigate Oscillation	Mitigation Time Limit	Pass / Fail
	Freq.	Level	Freq.	Level					
dB	MHz	dBm	MHz	dBm	dB	dB	sec	sec	
+5	833.9	-56.9	836.22	-65.5	8.6	<12	N/A	< 300	P
+4	833.9	-59.1	836.22	-68.5	9.4	<12	N/A	< 300	P
+3	833.9	-57.3	836.22	-67.1	9.8	<12	N/A	< 300	P
+2	833.9	-56.3	836.22	-67.6	11.3	<12	N/A	< 300	P
+1	833.9	-55.5	836.22	-68.4	12.9	<12	97	< 300	P
+0	833.9	-60.9	836.22	-70.3	9.4	<12	N/A	< 300	P
-1	833.9	-60.3	836.22	-71.4	11.1	<12	N/A	< 300	P
-2	833.9	-58.8	836.22	-71.8	13	<12	230	< 300	P
-3	833.9	-62.1	836.22	-73.5	11.4	<12	N/A	< 300	P
-4	833.9	-61.9	836.22	-73.8	11.9	<12	134	< 300	P
-5	833.9	-66.8	836.22	-76.3	9.5	<12	N/A	< 300	P

Oscillation Mitigation – Uplink Server Port 2 to Common Port 1									
Band	698 – 716 MHz								
Test Signal Type	CDMA								
Variable Attenuator Setting	Oscillations and Power Levels				Margin	Limit	Time to Mitigate Oscillation	Mitigation Time Limit	Pass / Fail
	Freq.	Level	Freq.	Level					
dB	MHz	dBm	MHz	dBm	dB	dB	sec	sec	
+5	709.45	-61	707.06	-70.7	9.7	<12	N/A	< 300	P
+4	709.45	-59.2	707.06	-69.6	10.4	<12	N/A	< 300	P
+3	709.45	-57.8	707.06	-70.4	12.6	<12	40	< 300	P
+2	709.45	-60.8	707.06	-71.7	10.9	<12	N/A	< 300	P
+1	709.45	-60.1	707.06	-71.6	11.5	<12	N/A	< 300	P
+0	709.45	-57.4	707.06	-72.4	15	<12	80	< 300	P
-1	709.45	-63.5	707.06	-74.2	10.7	<12	N/A	< 300	P
-2	709.45	-62.5	707.06	-75.3	12.8	<12	238	< 300	P
-3	709.45	-65.9	707.06	-75.2	9.3	<12	N/A	< 300	P
-4	709.45	-64.5	707.06	-76.1	11.6	<12	N/A	< 300	P
-5	709.45	-62.5	707.06	-77.6	15.1	<12	116	< 300	P

Oscillation Mitigation – Uplink Server Port 2 to Common Port 1									
Band	776 – 787 MHz								
Test Signal Type	CDMA								
Variable Attenuator Setting	Oscillations and Power Levels				Margin	Limit	Time to Mitigate Oscillation	Mitigation Time Limit	Pass / Fail
	Freq.	Level	Freq.	Level					
dB	MHz	dBm	MHz	dBm	dB	dB	sec	sec	
+5	779.37	-55.2	780.56	-66.4	11.2	<12	N/A	< 300	P
+4	779.37	-54.8	780.56	-67.4	12.6	<12	125	< 300	P
+3	779.37	-57.9	780.56	-68.1	10.2	<12	N/A	< 300	P
+2	779.37	-55.1	780.56	-69.4	14.3	<12	126	< 300	P
+1	779.37	-59.7	780.56	-70	10.3	<12	N/A	< 300	P
+0	779.37	-58.5	780.56	-70.2	11.7	<12	N/A	< 300	P
-1	779.37	-56.5	780.56	-71.5	15	<12	225	< 300	P
-2	779.37	-62.6	780.56	-72.4	9.8	<12	N/A	< 300	P
-3	779.37	-61.6	780.56	-73.4	11.8	<12	N/A	< 300	P
-4	779.37	-59.8	780.56	-74.1	14.3	<12	182	< 300	P
-5	779.37	-67.1	780.56	-76.6	9.5	<12	N/A	< 300	P

Oscillation Mitigation – Uplink Server Port 2 to Common Port 1									
Band	824 - 849 MHz								
Test Signal Type	CDMA								
Variable Attenuator Setting	Oscillations and Power Levels				Margin	Limit	Time to Mitigate Oscillation	Mitigation Time Limit	Pass / Fail
	Freq.	Level	Freq.	Level					
dB	MHz	dBm	MHz	dBm	dB	dB	sec	sec	
+5	835.9	-55.6	838.37	-66.5	10.9	<12	N/A	< 300	P
+4	835.9	-54	838.37	-67.5	13.5	<12	20	< 300	P
+3	835.9	-58.7	838.37	-68.8	10.1	<12	N/A	< 300	P
+2	835.9	-57.6	838.37	-69.5	11.9	<12	N/A	< 300	P
+1	835.9	-54.9	838.37	-69	14.1	<12	104	< 300	P
+0	835.9	-61.6	838.37	-70.6	9	<12	N/A	< 300	P
-1	835.9	-59.5	838.37	-70.8	11.3	<12	N/A	< 300	P
-2	835.9	-59.8	838.37	-71.6	11.8	<12	N/A	< 300	P
-3	835.9	-56.5	838.37	-73.6	17.1	<12	55	< 300	P
-4	835.9	-64.5	838.37	-74.9	10.4	<12	N/A	< 300	P
-5	835.9	-65.2	838.37	-75.8	10.6	<12	N/A	< 300	P

Oscillation Mitigation – Uplink Server Port 3 to Common Port 1									
Band	698 – 716 MHz								
Test Signal Type	CDMA								
Variable Attenuator Setting	Oscillations and Power Levels				Margin	Limit	Time to Mitigate Oscillation	Mitigation Time Limit	Pass / Fail
	Freq.	Level	Freq.	Level					
dB	MHz	dBm	MHz	dBm	dB	dB	sec	sec	
+5	709.26	-60.4	707.08	-69	8.6	<12	N/A	< 300	P
+4	709.26	-59.3	707.08	-69.4	10.1	<12	N/A	< 300	P
+3	709.26	-58.5	707.08	-70	11.5	<12	N/A	< 300	P
+2	709.26	-57.7	707.08	-70.6	12.9	<12	125	< 300	P
+1	709.26	-63.3	707.08	-73.9	10.6	<12	N/A	< 300	P
+0	709.26	-62.6	707.08	-73.4	10.8	<12	N/A	< 300	P
-1	709.26	-59.8	707.08	-73.2	13.4	<12	73	< 300	P
-2	709.26	-65.4	707.08	-74.7	9.3	<12	N/A	< 300	P
-3	709.26	-65.2	707.08	-76.4	11.2	<12	N/A	< 300	P
-4	709.26	-63.9	707.08	-75.5	11.6	<12	N/A	< 300	P
-5	709.26	-61.4	707.08	-76.2	14.8	<12	176	< 300	P

Oscillation Mitigation – Uplink Server Port 3 to Common Port 1									
Band	776 – 787 MHz								
Test Signal Type	CDMA								
Variable Attenuator Setting	Oscillations and Power Levels				Margin	Limit	Time to Mitigate Oscillation	Mitigation Time Limit	Pass / Fail
	Freq.	Level	Freq.	Level					
dB	MHz	dBm	MHz	dBm	dB	dB	sec	sec	
+5	779.34	-55.2	780.71	-65.3	10.1	<12	N/A	< 300	P
+4	779.34	-54.1	780.71	-67.4	13.3	<12	130	< 300	P
+3	779.34	-57.5	780.71	-68.4	10.9	<12	N/A	< 300	P
+2	779.34	-56.5	780.71	-69.5	13	<12	119	< 300	P
+1	779.34	-60.1	780.71	-70.1	10	<12	N/A	< 300	P
+0	779.34	-59.8	780.71	-70.8	11	<12	N/A	< 300	P
-1	779.34	-56.6	780.71	-71.5	14.9	<12	204	< 300	P
-2	779.34	-63.5	780.71	-73.5	10	<12	N/A	< 300	P
-3	779.34	-62	780.71	-73.7	11.7	<12	N/A	< 300	P
-4	779.34	-59.9	780.71	-74.4	14.5	<12	129	< 300	P
-5	779.34	-66.2	780.71	-76.5	10.3	<12	N/A	< 300	P

Oscillation Mitigation – Uplink Server Port 3 to Common Port 1									
Band	824 - 849 MHz								
Test Signal Type	CDMA								
Variable Attenuator Setting	Oscillations and Power Levels				Margin	Limit	Time to Mitigate Oscillation	Mitigation Time Limit	Pass / Fail
	Freq.	Level	Freq.	Level					
dB	MHz	dBm	MHz	dBm	dB	dB	sec	sec	
+5	835.77	-55.9	838.37	-65.7	9.8	<12	N/A	< 300	P
+4	835.77	-52.4	838.37	-67.4	15	<12	58	< 300	P
+3	835.77	-57.9	838.37	-68.5	10.6	<12	N/A	< 300	P
+2	835.77	-57.9	838.37	-69.7	11.8	<12	N/A	< 300	P
+1	835.77	-55.1	838.37	-68.9	13.8	<12	116	< 300	P
+0	835.77	-61.9	838.37	-71.6	9.7	<12	N/A	< 300	P
-1	835.77	-59.9	838.37	-71.8	11.9	<12	N/A	< 300	P
-2	835.77	-58.4	838.37	-72.6	14.2	<12	231	< 300	P
-3	835.77	-66.7	838.37	-75.1	8.4	<12	N/A	< 300	P
-4	835.77	-65.5	838.37	-75.1	9.6	<12	N/A	< 300	P
-5	835.77	-65.7	838.37	-76.1	10.4	<12	N/A	< 300	P

Oscillation Mitigation – Uplink Server Port 4 to Common Port 1									
Band	698 – 716 MHz								
Test Signal Type	CDMA								
Variable Attenuator Setting	Oscillations and Power Levels				Margin	Limit	Time to Mitigate Oscillation	Mitigation Time Limit	Pass / Fail
	Freq.	Level	Freq.	Level					
dB	MHz	dBm	MHz	dBm	dB	dB	sec	sec	
+5	708.07	-60.8	706.13	-69.9	9.1	<12	N/A	< 300	P
+4	708.07	-59.5	706.13	-70	10.5	<12	N/A	< 300	P
+3	708.07	-59.1	706.13	-70.8	11.7	<12	N/A	< 300	P
+2	708.07	-61.2	706.13	-71.1	9.9	<12	N/A	< 300	P
+1	708.07	-61	706.13	-72.7	11.7	<12	N/A	< 300	P
+0	708.07	-59.1	706.13	-73.4	14.3	<12	120	< 300	P
-1	708.07	-65.2	706.13	-74.6	9.4	<12	N/A	< 300	P
-2	708.07	-64.5	706.13	-75.5	11	<12	N/A	< 300	P
-3	708.07	-61.5	706.13	-77.1	15.6	<12	109	< 300	P
-4	708.07	-67.8	706.13	-77.6	9.8	<12	N/A	< 300	P
-5	708.07	-65.8	706.13	-77.4	11.6	<12	N/A	< 300	P

Oscillation Mitigation – Uplink Server Port 4 to Common Port 1									
Band	776 – 787 MHz								
Test Signal Type	CDMA								
Variable Attenuator Setting	Oscillations and Power Levels				Margin	Limit	Time to Mitigate Oscillation	Mitigation Time Limit	Pass / Fail
	Freq.	Level	Freq.	Level					
dB	MHz	dBm	MHz	dBm	dB	dB	sec	sec	
+5	778.62	-57.5	777.29	-66.8	9.3	<12	N/A	< 300	P
+4	778.62	-55.8	777.29	-68.2	12.4	<12	45	< 300	P
+3	778.62	-59.3	777.29	-69.5	10.2	<12	N/A	< 300	P
+2	778.62	-57.8	777.29	-71.1	13.3	<12	95	< 300	P
+1	778.62	-61	777.29	-71.3	10.3	<12	N/A	< 300	P
+0	778.62	-60.2	777.29	-71.1	10.9	<12	N/A	< 300	P
-1	778.62	-58.7	777.29	-73.2	14.5	<12	109	< 300	P
-2	778.62	-64.5	777.29	-74.1	9.6	<12	N/A	< 300	P
-3	778.62	-63.8	777.29	-75.1	11.3	<12	N/A	< 300	P
-4	778.62	-61.9	777.29	-75.6	13.7	<12	225	< 300	P
-5	778.62	-66.7	777.29	-76.9	10.2	<12	N/A	< 300	P

Oscillation Mitigation – Uplink Server Port 4 to Common Port 1									
Band	824 - 849 MHz								
Test Signal Type	CDMA								
Variable Attenuator Setting	Oscillations and Power Levels				Margin	Limit	Time to Mitigate Oscillation	Mitigation Time Limit	Pass / Fail
	Freq.	Level	Freq.	Level					
dB	MHz	dBm	MHz	dBm	dB	dB	sec	sec	
+5	834.4	-57.1	836.693	-65.9	8.8	<12	N/A	< 300	P
+4	834.4	-55.9	836.693	-65.4	9.5	<12	N/A	< 300	P
+3	834.4	-54.3	836.693	-64.5	10.2	<12	N/A	< 300	P
+2	834.4	-52.9	836.693	-66.5	13.6	<12	46	< 300	P
+1	834.4	-58.4	836.693	-68.8	10.4	<12	N/A	< 300	P
+0	834.4	-57.7	836.693	-69.4	11.7	<12	N/A	< 300	P
-1	834.4	-54.8	836.693	-69.1	14.3	<12	98	< 300	P
-2	834.4	-60.9	836.693	-71.8	10.9	<12	N/A	< 300	P
-3	834.4	-59.5	836.693	-71.3	11.8	<12	N/A	< 300	P
-4	834.4	-57.9	836.693	-72.6	14.7	<12	175	< 300	P
-5	834.4	-64.5	836.693	-74.7	10.2	<12	N/A	< 300	P

Downlink Oscillation Mitigation Test Data – Dedicated Ports

Oscillation Mitigation – Downlink Dedicated Port 3 to Server Port 1									
Band	728 - 746 MHz								
Test Signal Type	CDMA								
Variable Attenuator Setting	Oscillations and Power Levels				Margin	Limit	Time to Mitigate Oscillation	Mitigation Time Limit	Pass / Fail
	Freq.	Level	Freq.	Level					
dB	MHz	dBm	MHz	dBm	dB	dB	sec	sec	
+5	745.62	-57.5	742.91	-66.7	9.2	<12	N/A	< 300	P
+4	745.62	-56.8	742.91	-67.6	10.8	<12	N/A	< 300	P
+3	745.62	-55.6	742.91	-68.4	12.8	<12	82	< 300	P
+2	745.62	-59.3	742.91	-69.8	10.5	<12	N/A	< 300	P
+1	745.62	-50.4	742.91	-69.5	19.1	<12	80	< 300	P
+0	745.62	-62.1	742.91	-72.8	10.7	<12	N/A	< 300	P
-1	745.62	-62	742.91	-72.6	10.6	<12	N/A	< 300	P
-2	745.62	-60.4	742.91	-75.1	14.7	<12	123	< 300	P
-3	745.62	-66.2	742.91	-76.6	10.4	<12	N/A	< 300	P
-4	745.62	-64.7	742.91	-76.4	11.7	<12	N/A	< 300	P
-5	745.62	-63.1	742.91	-76.5	13.4	<12	40	< 300	P

Oscillation Mitigation – Downlink Dedicated Port 3 to Server Port 1									
Band	746 - 757 MHz								
Test Signal Type	CDMA								
Variable Attenuator Setting	Oscillations and Power Levels				Margin	Limit	Time to Mitigate Oscillation	Mitigation Time Limit	Pass / Fail
	Freq.	Level	Freq.	Level					
dB	MHz	dBm	MHz	dBm	dB	dB	sec	sec	
+5	747.6	-55.4	750	-68.3	12.9	<12	125	< 300	P
+4	747.6	-57.4	750	-68.2	10.8	<12	N/A	< 300	P
+3	747.6	-57.4	750	-68.7	11.3	<12	N/A	< 300	P
+2	747.6	-53.8	750	-70.7	16.9	<12	126	< 300	P
+1	747.6	-60.1	750	-71.9	11.8	<12	N/A	< 300	P
+0	747.6	-58.7	750	-73.2	14.5	<12	154	< 300	P
-1	747.6	-63.2	750	-73.3	10.1	<12	N/A	< 300	P
-2	747.6	-62.4	750	-74.1	11.7	<12	N/A	< 300	P
-3	747.6	-60	750	-74.3	14.3	<12	37	< 300	P
-4	747.6	-66.4	750	-76.9	10.5	<12	N/A	< 300	P
-5	747.6	-64.2	750	-77.8	13.6	<12	140	< 300	P

Oscillation Mitigation – Downlink Dedicated Port 2 to Server Port 1									
Band	869 - 894 MHz								
Test Signal Type	CDMA								
Variable Attenuator Setting	Oscillations and Power Levels				Margin	Limit	Time to Mitigate Oscillation	Mitigation Time Limit	Pass / Fail
	Freq.	Level	Freq.	Level					
dB	MHz	dBm	MHz	dBm	dB	dB	sec	sec	
+5	879.56	-58.9	881.5	-69	10.1	<12	N/A	< 300	P
+4	879.56	-57.6	881.5	-68.8	11.2	<12	N/A	< 300	P
+3	879.56	-55.2	881.5	-69.2	14	<12	206	< 300	P
+2	879.56	-60.5	881.5	-71.4	10.9	<12	N/A	< 300	P
+1	879.56	-59.5	881.5	-71.3	11.8	<12	N/A	< 300	P
+0	879.56	-56.3	881.5	-72.1	15.8	<12	127	< 300	P
-1	879.56	-61.9	881.5	-73.2	11.3	<12	N/A	< 300	P
-2	879.56	-62	881.5	-73.5	11.5	<12	N/A	< 300	P
-3	879.56	-59.7	881.5	-74.8	15.1	<12	26	< 300	P
-4	879.56	-66.6	881.5	-77.4	10.8	<12	N/A	< 300	P
-5	879.56	-64.8	881.5	-76.6	11.8	<12	N/A	< 300	P

Oscillation Mitigation – Downlink Dedicated Port 1 to Server Port 1									
Band	1930 - 1995 MHz								
Test Signal Type	CDMA								
Variable Attenuator Setting	Oscillations and Power Levels				Margin	Limit	Time to Mitigate Oscillation	Mitigation Time Limit	Pass / Fail
	Freq.	Level	Freq.	Level					
dB	MHz	dBm	MHz	dBm	dB	dB	sec	sec	
+5	1967.66	-46.4	1972.22	-60.5	14.1	<12	158	< 300	P
+4	1967.66	-50.6	1972.22	-60.6	10	<12	N/A	< 300	P
+3	1967.66	-47.9	1972.22	-61	13.1	<12	142	< 300	P
+2	1967.66	-52.1	1972.22	-62.8	10.7	<12	N/A	< 300	P
+1	1967.66	-51.4	1972.22	-63.2	11.8	<12	N/A	< 300	P
+0	1967.66	-49.1	1972.22	-63.8	14.7	<12	210	< 300	P
-1	1967.66	-55	1972.22	-65.3	10.3	<12	N/A	< 300	P
-2	1967.66	-54.6	1972.22	-66.4	11.8	<12	N/A	< 300	P
-3	1967.66	-52.8	1972.22	-66.4	13.6	<12	26	< 300	P
-4	1967.66	-59.5	1972.22	-68.5	9	<12	N/A	< 300	P
-5	1967.66	-58.2	1972.22	-69.1	10.9	<12	N/A	< 300	P

Oscillation Mitigation – Downlink Dedicated Port 1 to Server Port 1									
Band	2110 - 2155 MHz								
Test Signal Type	CDMA								
Variable Attenuator Setting	Oscillations and Power Levels				Margin	Limit	Time to Mitigate Oscillation	Mitigation Time Limit	Pass / Fail
	Freq.	Level	Freq.	Level					
dB	MHz	dBm	MHz	dBm	dB	dB	sec	sec	
+5	2122.61	-49.7	2127.09	-59.7	10	<12	N/A	< 300	P
+4	2122.61	-49.4	2127.09	-60.6	11.2	<12	N/A	< 300	P
+3	2122.61	-48	2127.09	-59.4	11.4	<12	N/A	< 300	P
+2	2122.61	-43.6	2127.09	-61	17.4	<12	170	< 300	P
+1	2122.61	-53.4	2127.09	-63.8	10.4	<12	N/A	< 300	P
+0	2122.61	-52.1	2127.09	-63.9	11.8	<12	N/A	< 300	P
-1	2122.61	-53.2	2127.09	-65.8	12.6	<12	22	< 300	P
-2	2122.61	-58.3	2127.09	-67.1	8.8	<12	N/A	< 300	P
-3	2122.61	-57.4	2127.09	-67.7	10.3	<12	N/A	< 300	P
-4	2122.61	-56.9	2127.09	-67.8	10.9	<12	N/A	< 300	P
-5	2122.61	-56.2	2127.09	-67.4	11.2	<12	N/A	< 300	P

Oscillation Mitigation – Downlink Dedicated Port 3 to Server Port 2									
Band	728 - 746 MHz								
Test Signal Type	CDMA								
Variable Attenuator Setting	Oscillations and Power Levels				Margin	Limit	Time to Mitigate Oscillation	Mitigation Time Limit	Pass / Fail
	Freq.	Level	Freq.	Level					
dB	MHz	dBm	MHz	dBm	dB	dB	sec	sec	
+5	741.52	-59	743.82	-67.3	8.3	<12	N/A	< 300	P
+4	741.52	-58.5	743.82	-68.2	9.7	<12	N/A	< 300	P
+3	741.52	-57.3	743.82	-68	10.7	<12	N/A	< 300	P
+2	741.52	-56.2	743.82	-68.1	11.9	<12	N/A	< 300	P
+1	741.52	-53.7	743.82	-68.9	15.2	<12	54	< 300	P
+0	741.52	-62.5	743.82	-71.3	8.8	<12	N/A	< 300	P
-1	741.52	-61.9	743.82	-71.8	9.9	<12	N/A	< 300	P
-2	741.52	-60.3	743.82	-71.6	11.3	<12	N/A	< 300	P
-3	741.52	-57.8	743.82	-72	14.2	<12	24	< 300	P
-4	741.52	-69.2	743.82	-75.7	6.5	<12	N/A	< 300	P
-5	741.52	-67	743.82	-75.5	8.5	<12	N/A	< 300	P

Oscillation Mitigation – Downlink Dedicated Port 3 to Server Port 2									
Band	746 - 757 MHz								
Test Signal Type	CDMA								
Variable Attenuator Setting	Oscillations and Power Levels				Margin	Limit	Time to Mitigate Oscillation	Mitigation Time Limit	Pass / Fail
	Freq.	Level	Freq.	Level					
dB	MHz	dBm	MHz	dBm	dB	dB	sec	sec	
+5	748.69	-56.8	750.91	-67.2	10.4	<12	N/A	< 300	P
+4	748.69	-56.4	750.91	-68	11.6	<12	N/A	< 300	P
+3	748.69	-55.7	750.91	-68.6	12.9	<12	91	< 300	P
+2	748.69	-59.8	750.91	-70.7	10.9	<12	N/A	< 300	P
+1	748.69	-58.9	750.91	-70.1	11.2	<12	N/A	< 300	P
+0	748.69	-58.7	750.91	-70.3	11.6	<12	N/A	< 300	P
-1	748.69	-56.2	750.91	-70.1	13.9	<12	95	< 300	P
-2	748.69	-61.9	750.91	-72.5	10.6	<12	N/A	< 300	P
-3	748.69	-59.3	750.91	-73.3	14	<12	45	< 300	P
-4	748.69	-63.9	750.91	-74.3	10.4	<12	N/A	< 300	P
-5	748.69	-62	750.91	-75.6	13.6	<12	125	< 300	P

Oscillation Mitigation – Downlink Dedicated Port 2 to Server Port 2									
Band	869 - 894 MHz								
Test Signal Type	CDMA								
Variable Attenuator Setting	Oscillations and Power Levels				Margin	Limit	Time to Mitigate Oscillation	Mitigation Time Limit	Pass / Fail
	Freq.	Level	Freq.	Level					
dB	MHz	dBm	MHz	dBm	dB	dB	sec	sec	
+5	876.91	-60.4	878.66	-69.2	8.8	<12	N/A	< 300	P
+4	876.91	-58.7	878.66	-68.9	10.2	<12	N/A	< 300	P
+3	876.91	-58.4	878.66	-69.5	11.1	<12	N/A	< 300	P
+2	876.91	-56.6	878.66	-69.6	13	<12	105	< 300	P
+1	876.91	-62.1	878.66	-72.6	10.5	<12	N/A	< 300	P
+0	876.91	-60.9	878.66	-72.2	11.3	<12	N/A	< 300	P
-1	876.91	-60.6	878.66	-73.6	13	<12	57	< 300	P
-2	876.91	-65.8	878.66	-74.9	9.1	<12	N/A	< 300	P
-3	876.91	-64.4	878.66	-74.8	10.4	<12	N/A	< 300	P
-4	876.91	-61.7	878.66	-74.9	13.2	<12	70	< 300	P
-5	876.91	-68.1	878.66	-77.8	9.7	<12	N/A	< 300	P

Oscillation Mitigation – Downlink Dedicated Port 1 to Server Port 2									
Band	1930 - 1995 MHz								
Test Signal Type	CDMA								
Variable Attenuator Setting	Oscillations and Power Levels				Margin	Limit	Time to Mitigate Oscillation	Mitigation Time Limit	Pass / Fail
	Freq.	Level	Freq.	Level					
dB	MHz	dBm	MHz	dBm	dB	dB	sec	sec	
+5	1945.85	-43.6	1942.21	-59.4	15.8	<12	165	< 300	P
+4	1945.85	-50.3	1942.21	-60.9	10.6	<12	N/A	< 300	P
+3	1945.85	-37.1	1942.21	-60.2	23.1	<12	128	< 300	P
+2	1945.85	-51.4	1942.21	-61.9	10.5	<12	N/A	< 300	P
+1	1945.85	-50.7	1942.21	-61.6	10.9	<12	N/A	< 300	P
+0	1945.85	-48.5	1942.21	-63.8	15.3	<12	203	< 300	P
-1	1945.85	-55.1	1942.21	-65.3	10.2	<12	N/A	< 300	P
-2	1945.85	-53.9	1942.21	-64.7	10.8	<12	N/A	< 300	P
-3	1945.85	-50.7	1942.21	-66	15.3	<12	120	< 300	P
-4	1945.85	-56.9	1942.21	-68	11.1	<12	N/A	< 300	P
-5	1945.85	-56	1942.21	-68.8	12.8	<12	29	< 300	P

Oscillation Mitigation – Downlink Dedicated Port 1 to Server Port 2									
Band	2110 - 2155 MHz								
Test Signal Type	CDMA								
Variable Attenuator Setting	Oscillations and Power Levels				Margin	Limit	Time to Mitigate Oscillation	Mitigation Time Limit	Pass / Fail
	Freq.	Level	Freq.	Level					
dB	MHz	dBm	MHz	dBm	dB	dB	sec	sec	
+5	2147.17	-49.8	2141.09	-61	11.2	<12	N/A	< 300	P
+4	2147.17	-48.6	2141.09	-59.9	11.3	<12	N/A	< 300	P
+3	2147.17	-46.3	2141.09	-60.9	14.6	<12	45	< 300	P
+2	2147.17	-52.1	2141.09	-62.5	10.4	<12	N/A	< 300	P
+1	2147.17	-50.8	2141.09	-61.9	11.1	<12	N/A	< 300	P
+0	2147.17	-35.9	2141.09	-61.9	26	<12	101	< 300	P
-1	2147.17	-55	2141.09	-66.6	11.6	<12	N/A	< 300	P
-2	2147.17	-52.9	2141.09	-67.5	14.6	<12	152	< 300	P
-3	2147.17	-56.4	2141.09	-66.7	10.3	<12	N/A	< 300	P
-4	2147.17	-55	2141.09	-66.9	11.9	<12	N/A	< 300	P
-5	2147.17	-51.8	2141.09	-67.5	15.7	<12	22	< 300	P

Oscillation Mitigation – Downlink Dedicated Port 3 to Server Port 3									
Band	728 - 746 MHz								
Test Signal Type	CDMA								
Variable Attenuator Setting	Oscillations and Power Levels				Margin	Limit	Time to Mitigate Oscillation	Mitigation Time Limit	Pass / Fail
	Freq.	Level	Freq.	Level					
dB	MHz	dBm	MHz	dBm	dB	dB	sec	sec	
+5	745.06	-57.7	742.55	-66.7	9	<12	N/A	< 300	P
+4	745.06	-57.1	742.55	-67.5	10.4	<12	N/A	< 300	P
+3	745.06	-56	742.55	-66.8	10.8	<12	N/A	< 300	P
+2	745.06	-53.6	742.55	-67.8	14.2	<12	68	< 300	P
+1	745.06	-59.3	742.55	-69.3	10	<12	N/A	< 300	P
+0	745.06	-59	742.55	-70.3	11.3	<12	N/A	< 300	P
-1	745.06	-40.9	742.55	-69.8	28.9	<12	127	< 300	P
-2	745.06	-62.8	742.55	-73.8	11	<12	N/A	< 300	P
-3	745.06	-62	742.55	-73.7	11.7	<12	N/A	< 300	P
-4	745.06	-60	742.55	-74.8	14.8	<12	115	< 300	P
-5	745.06	-67.3	742.55	-76.9	9.6	<12	N/A	< 300	P

Oscillation Mitigation – Downlink Dedicated Port 3 to Server Port 3									
Band	746 - 757 MHz								
Test Signal Type	CDMA								
Variable Attenuator Setting	Oscillations and Power Levels				Margin	Limit	Time to Mitigate Oscillation	Mitigation Time Limit	Pass / Fail
	Freq.	Level	Freq.	Level					
dB	MHz	dBm	MHz	dBm	dB	dB	sec	sec	
+5	747.6	-53.3	749.59	-66.4	13.1	<12	91	< 300	P
+4	747.6	-56.6	749.59	-67.9	11.3	<12	N/A	< 300	P
+3	747.6	-56.3	749.59	-68.9	12.6	<12	88	< 300	P
+2	747.6	-59.6	749.59	-71	11.4	<12	N/A	< 300	P
+1	747.6	-58.3	749.59	-69.9	11.6	<12	N/A	< 300	P
+0	747.6	-56.4	749.59	-71.2	14.8	<12	33	< 300	P
-1	747.6	-63.1	749.59	-73.8	10.7	<12	N/A	< 300	P
-2	747.6	-62.3	749.59	-73.2	10.9	<12	N/A	< 300	P
-3	747.6	-59.5	749.59	-73.7	14.2	<12	96	< 300	P
-4	747.6	-65.5	749.59	-76.2	10.7	<12	N/A	< 300	P
-5	747.6	-65.4	749.59	-76.3	10.9	<12	N/A	< 300	P

Oscillation Mitigation – Downlink Dedicated Port 2 to Server Port 3									
Band	869 - 894 MHz								
Test Signal Type	CDMA								
Variable Attenuator Setting	Oscillations and Power Levels				Margin	Limit	Time to Mitigate Oscillation	Mitigation Time Limit	Pass / Fail
	Freq.	Level	Freq.	Level					
dB	MHz	dBm	MHz	dBm	dB	dB	sec	sec	
+5	879.45	-59.5	881.44	-67.6	8.1	<12	N/A	< 300	P
+4	879.45	-57.2	881.44	-68.2	11	<12	N/A	< 300	P
+3	879.45	-55.2	881.44	-69.6	14.4	<12	68	< 300	P
+2	879.45	-60.3	881.44	-71	10.7	<12	N/A	< 300	P
+1	879.45	-59.4	881.44	-71	11.6	<12	N/A	< 300	P
+0	879.45	-56	881.44	-72.3	16.3	<12	225	< 300	P
-1	879.45	-60.8	881.44	-72.5	11.7	<12	N/A	< 300	P
-2	879.45	-59.3	881.44	-73.2	13.9	<12	75	< 300	P
-3	879.45	-65.7	881.44	-75.6	9.9	<12	N/A	< 300	P
-4	879.45	-63	881.44	-76.4	13.4	<12	62	< 300	P
-5	879.45	-66.7	881.44	-77.6	10.9	<12	N/A	< 300	P

Oscillation Mitigation – Downlink Dedicated Port 1 to Server Port 3									
Band	1930 - 1995 MHz								
Test Signal Type	CDMA								
Variable Attenuator Setting	Oscillations and Power Levels				Margin	Limit	Time to Mitigate Oscillation	Mitigation Time Limit	Pass / Fail
	Freq.	Level	Freq.	Level					
dB	MHz	dBm	MHz	dBm	dB	dB	sec	sec	
+5	1948.59	-48.4	1952.57	-59.6	11.2	<12	N/A	< 300	P
+4	1948.59	-47	1952.57	-60	13	<12	122	< 300	P
+3	1948.59	-50.3	1952.57	-61.7	11.4	<12	N/A	< 300	P
+2	1948.59	-49.4	1952.57	-61	11.6	<12	N/A	< 300	P
+1	1948.59	-48.8	1952.57	-63	14.2	<12	89	< 300	P
+0	1948.59	-53.9	1952.57	-64.8	10.9	<12	N/A	< 300	P
-1	1948.59	-52.6	1952.57	-65.4	12.8	<12	45	< 300	P
-2	1948.59	-56.1	1952.57	-64.8	8.7	<12	N/A	< 300	P
-3	1948.59	-55.4	1952.57	-66.1	10.7	<12	N/A	< 300	P
-4	1948.59	-53.9	1952.57	-67.1	13.2	<12	116	< 300	P
-5	1948.59	-59.8	1952.57	-71.1	11.3	<12	N/A	< 300	P

Oscillation Mitigation – Downlink Dedicated Port 1 to Server Port 3									
Band	2110 - 2155 MHz								
Test Signal Type	CDMA								
Variable Attenuator Setting	Oscillations and Power Levels				Margin	Limit	Time to Mitigate Oscillation	Mitigation Time Limit	Pass / Fail
	Freq.	Level	Freq.	Level					
dB	MHz	dBm	MHz	dBm	dB	dB	sec	sec	
+5	2149.81	-50.9	2144.08	-59.2	8.3	<12	N/A	< 300	P
+4	2149.81	-49.8	2144.08	-60.4	10.6	<12	N/A	< 300	P
+3	2149.81	-48.9	2144.08	-59.8	10.9	<12	N/A	< 300	P
+2	2149.81	-46.3	2144.08	-60.4	14.1	<12	31	< 300	P
+1	2149.81	-51.7	2144.08	-62.2	10.5	<12	N/A	< 300	P
+0	2149.81	-50.6	2144.08	-62.5	11.9	<12	N/A	< 300	P
-1	2149.81	-32.6	2144.08	-62.3	29.7	<12	112	< 300	P
-2	2149.81	-56.3	2144.08	-65.9	9.6	<12	N/A	< 300	P
-3	2149.81	-55.6	2144.08	-67.2	11.6	<12	N/A	< 300	P
-4	2149.81	-53.6	2144.08	-67.3	13.7	<12	95	< 300	P
-5	2149.81	-58.9	2144.08	-68.6	9.7	<12	N/A	< 300	P

Oscillation Mitigation – Downlink Dedicated Port 3 to Server Port 4									
Band	728 - 746 MHz								
Test Signal Type	CDMA								
Variable Attenuator Setting	Oscillations and Power Levels				Margin	Limit	Time to Mitigate Oscillation	Mitigation Time Limit	Pass / Fail
	Freq.	Level	Freq.	Level					
dB	MHz	dBm	MHz	dBm	dB	dB	sec	sec	
+5	743.75	-59	741.35	-67.4	8.4	<12	N/A	< 300	P
+4	743.75	-58.1	741.35	-68.2	10.1	<12	N/A	< 300	P
+3	743.75	-57.3	741.35	-67.9	10.6	<12	N/A	< 300	P
+2	743.75	-55.2	741.35	-69.8	14.6	<12	90	< 300	P
+1	743.75	-63.1	741.35	-71.5	8.4	<12	N/A	< 300	P
+0	743.75	-61.8	741.35	-71.9	10.1	<12	N/A	< 300	P
-1	743.75	-62.3	741.35	-72.9	10.6	<12	N/A	< 300	P
-2	743.75	-60.2	741.35	-73.1	12.9	<12	104	< 300	P
-3	743.75	-67.8	741.35	-75.8	8	<12	N/A	< 300	P
-4	743.75	-65.4	741.35	-75.8	10.4	<12	N/A	< 300	P
-5	743.75	-65.2	741.35	-76.1	10.9	<12	N/A	< 300	P

Oscillation Mitigation – Downlink Dedicated Port 3 to Server Port 4									
Band	746 - 757 MHz								
Test Signal Type	CDMA								
Variable Attenuator Setting	Oscillations and Power Levels				Margin	Limit	Time to Mitigate Oscillation	Mitigation Time Limit	Pass / Fail
	Freq.	Level	Freq.	Level					
dB	MHz	dBm	MHz	dBm	dB	dB	sec	sec	
+5	746.12	-57.7	748.14	-67	9.3	<12	N/A	< 300	P
+4	746.12	-56.1	748.14	-67.4	11.3	<12	N/A	< 300	P
+3	746.12	-54	748.14	-68.3	14.3	<12	50	< 300	P
+2	746.12	-58.3	748.14	-69.7	11.4	<12	N/A	< 300	P
+1	746.12	-56.6	748.14	-69.9	13.3	<12	135	< 300	P
+0	746.12	-60.5	748.14	-72	11.5	<12	N/A	< 300	P
-1	746.12	-59.5	748.14	-72	12.5	<12	155	< 300	P
-2	746.12	-62.3	748.14	-73.5	11.2	<12	N/A	< 300	P
-3	746.12	-60.1	748.14	-74.9	14.8	<12	65	< 300	P
-4	746.12	-66.7	748.14	-75.2	8.5	<12	N/A	< 300	P
-5	746.12	-66.3	748.14	-76.8	10.5	<12	N/A	< 300	P

Oscillation Mitigation – Downlink Dedicated Port 2 to Server Port 4									
Band	869 - 894 MHz								
Test Signal Type	CDMA								
Variable Attenuator Setting	Oscillations and Power Levels				Margin	Limit	Time to Mitigate Oscillation	Mitigation Time Limit	Pass / Fail
	Freq.	Level	Freq.	Level					
dB	MHz	dBm	MHz	dBm	dB	dB	sec	sec	
+5	878.26	-58.8	880.25	-69	10.2	<12	N/A	< 300	P
+4	878.26	-56.9	880.25	-68	11.1	<12	N/A	< 300	P
+3	878.26	-56.6	880.25	-68.1	11.5	<12	N/A	< 300	P
+2	878.26	-59.9	880.25	-71.7	11.8	<12	N/A	< 300	P
+1	878.26	-50.1	880.25	-71.3	21.2	<12	137	< 300	P
+0	878.26	-61.1	880.25	-71.9	10.8	<12	N/A	< 300	P
-1	878.26	-59.9	880.25	-74.6	14.7	<12	240	< 300	P
-2	878.26	-64.8	880.25	-75.3	10.5	<12	N/A	< 300	P
-3	878.26	-64.3	880.25	-75.3	11	<12	N/A	< 300	P
-4	878.26	-61	880.25	-75.9	14.9	<12	118	< 300	P
-5	878.26	-66.6	880.25	-77.4	10.8	<12	N/A	< 300	P

Oscillation Mitigation – Downlink Dedicated Port 1 to Server Port 4									
Band	1930 - 1995 MHz								
Test Signal Type	CDMA								
Variable Attenuator Setting	Oscillations and Power Levels				Margin	Limit	Time to Mitigate Oscillation	Mitigation Time Limit	Pass / Fail
	Freq.	Level	Freq.	Level					
dB	MHz	dBm	MHz	dBm	dB	dB	sec	sec	
+5	1967.25	-48.2	1971.88	-59.9	11.7	<12	N/A	< 300	P
+4	1967.25	-46.4	1971.88	-60.5	14.1	<12	135	< 300	P
+3	1967.25	-51.6	1971.88	-62.1	10.5	<12	N/A	< 300	P
+2	1967.25	-51.5	1971.88	-63.1	11.6	<12	N/A	< 300	P
+1	1967.25	-33	1971.88	-61.5	28.5	<12	94	< 300	P
+0	1967.25	-56.5	1971.88	-65.4	8.9	<12	N/A	< 300	P
-1	1967.25	-54.6	1971.88	-65.6	11	<12	N/A	< 300	P
-2	1967.25	-51.3	1971.88	-66.7	15.4	<12	149	< 300	P
-3	1967.25	-57.6	1971.88	-68.8	11.2	<12	N/A	< 300	P
-4	1967.25	-57.3	1971.88	-69.1	11.8	<12	N/A	< 300	P
-5	1967.25	-55.7	1971.88	-69.8	14.1	<12	32	< 300	P

Oscillation Mitigation – Downlink Dedicated Port 1 to Server Port 4									
Band	2110 - 2155 MHz								
Test Signal Type	CDMA								
Variable Attenuator Setting	Oscillations and Power Levels				Margin	Limit	Time to Mitigate Oscillation	Mitigation Time Limit	Pass / Fail
	Freq.	Level	Freq.	Level					
dB	MHz	dBm	MHz	dBm	dB	dB	sec	sec	
+5	2151.68	-52.2	2146.53	-60.3	8.1	<12	N/A	< 300	P
+4	2151.68	-52.4	2146.53	-61	8.6	<12	N/A	< 300	P
+3	2151.68	-50.6	2146.53	-61	10.4	<12	N/A	< 300	P
+2	2151.68	-49.9	2146.53	-61.1	11.2	<12	N/A	< 300	P
+1	2151.68	-48.1	2146.53	-61.8	13.7	<12	28	< 300	P
+0	2151.68	-53.5	2146.53	-63.7	10.2	<12	N/A	< 300	P
-1	2151.68	-51.5	2146.53	-63.3	11.8	<12	N/A	< 300	P
-2	2151.68	-37.8	2146.53	-63.5	25.7	<12	121	< 300	P
-3	2151.68	-56.8	2146.53	-66.1	9.3	<12	N/A	< 300	P
-4	2151.68	-54.8	2146.53	-66.7	11.9	<12	N/A	< 300	P
-5	2151.68	-53.2	2146.53	-67.3	14.1	<12	109	< 300	P

Downlink Oscillation Mitigation Test Data – Common Port

Oscillation Mitigation – Downlink Common Donor Port 1 to Server Port 1									
Band	728 - 746 MHz								
Test Signal Type	CDMA								
Variable Attenuator Setting	Oscillations and Power Levels				Margin	Limit	Time to Mitigate Oscillation	Mitigation Time Limit	Pass / Fail
	Freq.	Level	Freq.	Level					
dB	MHz	dBm	MHz	dBm	dB	dB	sec	sec	
+5	739.64	-58.6	741.72	-68.7	10.1	<12	N/A	< 300	P
+4	739.64	-56.5	741.72	-68	11.5	<12	N/A	< 300	P
+3	739.64	-55.2	741.72	-68.5	13.3	<12	220	< 300	P
+2	739.64	-62.8	741.72	-71.6	8.8	<12	N/A	< 300	P
+1	739.64	-61.8	741.72	-71.4	9.6	<12	N/A	< 300	P
+0	739.64	-61.3	741.72	-72.2	10.9	<12	N/A	< 300	P
-1	739.64	-58.5	741.72	-72.8	14.3	<12	109	< 300	P
-2	739.64	-66.7	741.72	-75.9	9.2	<12	N/A	< 300	P
-3	739.64	-65.4	741.72	-76.3	10.9	<12	N/A	< 300	P
-4	739.64	-65.8	741.72	-77.5	11.7	<12	N/A	< 300	P
-5	739.64	-64.9	741.72	-77.9	13	<12	105	< 300	P

Oscillation Mitigation – Downlink Common Donor Port 1 to Server Port 1									
Band	746 - 757 MHz								
Test Signal Type	CDMA								
Variable Attenuator Setting	Oscillations and Power Levels				Margin	Limit	Time to Mitigate Oscillation	Mitigation Time Limit	Pass / Fail
	Freq.	Level	Freq.	Level					
dB	MHz	dBm	MHz	dBm	dB	dB	sec	sec	
+5	746.44	-57.6	748.81	-67.3	9.7	<12	N/A	< 300	P
+4	746.44	-56.2	748.81	-67.7	11.5	<12	N/A	< 300	P
+3	746.44	-55.8	748.81	-67.5	11.7	<12	N/A	< 300	P
+2	746.44	-53.7	748.81	-68.2	14.5	<12	68	< 300	P
+1	746.44	-60.2	748.81	-70.8	10.6	<12	N/A	< 300	P
+0	746.44	-59.1	748.81	-71	11.9	<12	N/A	< 300	P
-1	746.44	-57.1	748.81	-71.7	14.6	<12	138	< 300	P
-2	746.44	-63.8	748.81	-73.2	9.4	<12	N/A	< 300	P
-3	746.44	-61.7	748.81	-73.5	11.8	<12	N/A	< 300	P
-4	746.44	-59.8	748.81	-73.8	14	<12	34	< 300	P
-5	746.44	-66.5	748.81	-75.8	9.3	<12	N/A	< 300	P

Oscillation Mitigation – Downlink Common Donor Port 1 to Server Port 1									
Band	869 - 894 MHz								
Test Signal Type	CDMA								
Variable Attenuator Setting	Oscillations and Power Levels				Margin	Limit	Time to Mitigate Oscillation	Mitigation Time Limit	Pass / Fail
	Freq.	Level	Freq.	Level					
dB	MHz	dBm	MHz	dBm	dB	dB	sec	sec	
+5	878.02	-57.4	879.98	-68.7	11.3	<12	N/A	< 300	P
+4	878.02	-55.2	879.98	-68.5	13.3	<12	120	< 300	P
+3	878.02	-59.4	879.98	-70.2	10.8	<12	N/A	< 300	P
+2	878.02	-58.7	879.98	-70.4	11.7	<12	N/A	< 300	P
+1	878.02	-47.6	879.98	-69.7	22.1	<12	88	< 300	P
+0	878.02	-62.8	879.98	-72.2	9.4	<12	N/A	< 300	P
-1	878.02	-62	879.98	-72.5	10.5	<12	N/A	< 300	P
-2	878.02	-60.8	879.98	-73.5	12.7	<12	115	< 300	P
-3	878.02	-65.2	879.98	-75	9.8	<12	N/A	< 300	P
-4	878.02	-62.9	879.98	-75.2	12.3	<12	45	< 300	P
-5	878.02	-66.7	879.98	-74.6	7.9	<12	N/A	< 300	P

Oscillation Mitigation – Downlink Common Donor Port 1 to Server Port 2									
Band	728 - 746 MHz								
Test Signal Type	CDMA								
Variable Attenuator Setting	Oscillations and Power Levels				Margin	Limit	Time to Mitigate Oscillation	Mitigation Time Limit	Pass / Fail
	Freq.	Level	Freq.	Level					
dB	MHz	dBm	MHz	dBm	dB	dB	sec	sec	
+5	745.12	-58	742.89	-67.7	9.7	<12	N/A	< 300	P
+4	745.12	-57.1	742.89	-67.6	10.5	<12	N/A	< 300	P
+3	745.12	-55.2	742.89	-68.7	13.5	<12	36	< 300	P
+2	745.12	-58.8	742.89	-68.7	9.9	<12	N/A	< 300	P
+1	745.12	-59.6	742.89	-70.2	10.6	<12	N/A	< 300	P
+0	745.12	-48.3	742.89	-69	20.7	<12	112	< 300	P
-1	745.12	-64.6	742.89	-73.8	9.2	<12	N/A	< 300	P
-2	745.12	-63.1	742.89	-73.6	10.5	<12	N/A	< 300	P
-3	745.12	-62.6	742.89	-73.9	11.3	<12	N/A	< 300	P
-4	745.12	-60.6	742.89	-74.5	13.9	<12	107	< 300	P
-5	745.12	-66.2	742.89	-75.9	9.7	<12	N/A	< 300	P

Oscillation Mitigation – Downlink Common Donor Port 1 to Server Port 2									
Band	746 - 757 MHz								
Test Signal Type	CDMA								
Variable Attenuator Setting	Oscillations and Power Levels				Margin	Limit	Time to Mitigate Oscillation	Mitigation Time Limit	Pass / Fail
	Freq.	Level	Freq.	Level					
dB	MHz	dBm	MHz	dBm	dB	dB	sec	sec	
+5	747.29	-56.6	748.93	-67.3	10.7	<12	N/A	< 300	P
+4	747.29	-55.7	748.93	-68.7	13	<12	110	< 300	P
+3	747.29	-58.3	748.93	-67.9	9.6	<12	N/A	< 300	P
+2	747.29	-58.3	748.93	-69.4	11.1	<12	N/A	< 300	P
+1	747.29	-46.8	748.93	-68.2	21.4	<12	118	< 300	P
+0	747.29	-61	748.93	-71.3	10.3	<12	N/A	< 300	P
-1	747.29	-61.2	748.93	-71.9	10.7	<12	N/A	< 300	P
-2	747.29	-58	748.93	-73.2	15.2	<12	121	< 300	P
-3	747.29	-62.5	748.93	-72.9	10.4	<12	N/A	< 300	P
-4	747.29	-60.7	748.93	-74.4	13.7	<12	50	< 300	P
-5	747.29	-66.4	748.93	-76	9.6	<12	N/A	< 300	P

Oscillation Mitigation – Downlink Common Donor Port 1 to Server Port 2									
Band	869 - 894 MHz								
Test Signal Type	CDMA								
Variable Attenuator Setting	Oscillations and Power Levels				Margin	Limit	Time to Mitigate Oscillation	Mitigation Time Limit	Pass / Fail
	Freq.	Level	Freq.	Level					
dB	MHz	dBm	MHz	dBm	dB	dB	sec	sec	
+5	878.91	-58.1	880.98	-68	9.9	<12	N/A	< 300	P
+4	878.91	-56.2	880.98	-68.1	11.9	<12	N/A	< 300	P
+3	878.91	-55	880.98	-68.5	13.5	<12	105	< 300	P
+2	878.91	-60.7	880.98	-70.3	9.6	<12	N/A	< 300	P
+1	878.91	-60.8	880.98	-71.5	10.7	<12	N/A	< 300	P
+0	878.91	-58.2	880.98	-72.47	14.27	<12	125	< 300	P
-1	878.91	-64.3	880.98	-73.7	9.4	<12	N/A	< 300	P
-2	878.91	-63	880.98	-74.5	11.5	<12	N/A	< 300	P
-3	878.91	-61.2	880.98	-74.6	13.4	<12	44	< 300	P
-4	878.91	-65.7	880.98	-75.8	10.1	<12	N/A	< 300	P
-5	878.91	-65.8	880.98	-77.5	11.7	<12	N/A	< 300	P

Oscillation Mitigation – Downlink Common Donor Port 1 to Server Port 3									
Band	728 - 746 MHz								
Test Signal Type	CDMA								
Variable Attenuator Setting	Oscillations and Power Levels				Margin	Limit	Time to Mitigate Oscillation	Mitigation Time Limit	Pass / Fail
	Freq.	Level	Freq.	Level					
dB	MHz	dBm	MHz	dBm	dB	dB	sec	sec	
+5	739.3	-57.8	736.93	-67.5	9.7	<12	N/A	< 300	P
+4	739.3	-56.7	736.93	-68	11.3	<12	N/A	< 300	P
+3	739.3	-55	736.93	-67.6	12.6	<12	14	< 300	P
+2	739.3	-62	736.93	-72.7	10.7	<12	N/A	< 300	P
+1	739.3	-60	736.93	-70.9	10.9	<12	N/A	< 300	P
+0	739.3	-60.6	736.93	-72.1	11.5	<12	N/A	< 300	P
-1	739.3	-12.8	736.93	-70.3	57.5	<12	85	< 300	P
-2	739.3	-67.6	736.93	-73.8	6.2	<12	N/A	< 300	P
-3	739.3	-66.5	736.93	-74.7	8.2	<12	N/A	< 300	P
-4	739.3	-66	736.93	-75.6	9.6	<12	N/A	< 300	P
-5	739.3	-65	736.93	-75.9	10.9	<12	N/A	< 300	P

Oscillation Mitigation – Downlink Common Donor Port 1 to Server Port 3									
Band	746 - 757 MHz								
Test Signal Type	CDMA								
Variable Attenuator Setting	Oscillations and Power Levels				Margin	Limit	Time to Mitigate Oscillation	Mitigation Time Limit	Pass / Fail
	Freq.	Level	Freq.	Level					
dB	MHz	dBm	MHz	dBm	dB	dB	sec	sec	
+5	746.15	-56.6	748.15	-67.1	10.5	<12	N/A	< 300	P
+4	746.15	-54.5	748.15	-66.3	11.8	<12	N/A	< 300	P
+3	746.15	-52.1	748.15	-67.5	15.4	<12	49	< 300	P
+2	746.15	-59.1	748.15	-69.6	10.5	<12	N/A	< 300	P
+1	746.15	-58	748.15	-69.5	11.5	<12	N/A	< 300	P
+0	746.15	-31.7	748.15	-68.9	37.2	<12	127	< 300	P
-1	746.15	-61.3	748.15	-72	10.7	<12	N/A	< 300	P
-2	746.15	-61.2	748.15	-72.5	11.3	<12	N/A	< 300	P
-3	746.15	-59	748.15	-72.8	13.8	<12	121	< 300	P
-4	746.15	-64.7	748.15	-74.6	9.9	<12	N/A	< 300	P
-5	746.15	-64.8	748.15	-75.6	10.8	<12	N/A	< 300	P

Oscillation Mitigation – Downlink Common Donor Port 1 to Server Port 3									
Band	869 - 894 MHz								
Test Signal Type	CDMA								
Variable Attenuator Setting	Oscillations and Power Levels				Margin	Limit	Time to Mitigate Oscillation	Mitigation Time Limit	Pass / Fail
	Freq.	Level	Freq.	Level					
dB	MHz	dBm	MHz	dBm	dB	dB	sec	sec	
+5	877.95	-57.4	879.94	-68.7	11.3	<12	N/A	< 300	P
+4	877.95	-55.8	879.94	-68.6	12.8	<12	48	< 300	P
+3	877.95	-59.8	879.94	-70	10.2	<12	N/A	< 300	P
+2	877.95	-58.9	879.94	-70.2	11.3	<12	N/A	< 300	P
+1	877.95	-57.6	879.94	-71.2	13.6	<12	137	< 300	P
+0	877.95	-63.4	879.94	-73.1	9.7	<12	N/A	< 300	P
-1	877.95	-64.4	879.94	-75.4	11	<12	N/A	< 300	P
-2	877.95	-63.1	879.94	-74	10.9	<12	N/A	< 300	P
-3	877.95	-61.3	879.94	-75	13.7	<12	119	< 300	P
-4	877.95	-66.9	879.94	-76.9	10	<12	N/A	< 300	P
-5	877.95	-65.6	879.94	-76.7	11.1	<12	N/A	< 300	P

Oscillation Mitigation – Downlink Common Donor Port 1 to Server Port 41									
Band	728 - 746 MHz								
Test Signal Type	CDMA								
Variable Attenuator Setting	Oscillations and Power Levels				Margin	Limit	Time to Mitigate Oscillation	Mitigation Time Limit	Pass / Fail
	Freq.	Level	Freq.	Level					
dB	MHz	dBm	MHz	dBm	dB	dB	sec	sec	
+5	742.6	-60.9	740.3	-68.3	7.4	<12	N/A	< 300	P
+4	742.6	-59	740.3	-69	10	<12	N/A	< 300	P
+3	742.6	-59	740.3	-69.8	10.8	<12	N/A	< 300	P
+2	742.6	-57.8	740.3	-69.6	11.8	<12	N/A	< 300	P
+1	742.6	-56.7	740.3	-70.7	14	<12	76	< 300	P
+0	742.6	-64.1	740.3	-73.4	9.3	<12	N/A	< 300	P
-1	742.6	-62.5	740.3	-72.6	10.1	<12	N/A	< 300	P
-2	742.6	-61.9	740.3	-72.6	10.7	<12	N/A	< 300	P
-3	742.6	-60.5	740.3	-73.7	13.2	<12	17	< 300	P
-4	742.6	-67.4	740.3	-75.6	8.2	<12	N/A	< 300	P
-5	742.6	-66	740.3	-76.6	10.6	<12	N/A	< 300	P

Oscillation Mitigation – Downlink Common Donor Port 1 to Server Port 4									
Band	746 - 757 MHz								
Test Signal Type	CDMA								
Variable Attenuator Setting	Oscillations and Power Levels				Margin	Limit	Time to Mitigate Oscillation	Mitigation Time Limit	Pass / Fail
	Freq.	Level	Freq.	Level					
dB	MHz	dBm	MHz	dBm	dB	dB	sec	sec	
+5	748.92	-60.5	751.26	-68.6	8.1	<12	N/A	< 300	P
+4	748.92	-59.3	751.26	-68.4	9.1	<12	N/A	< 300	P
+3	748.92	-57.2	751.26	-69	11.8	<12	N/A	< 300	P
+2	748.92	-56.6	751.26	-69.5	12.9	<12	101	< 300	P
+1	748.92	-60.6	751.26	-70.6	10	<12	N/A	< 300	P
+0	748.92	-58.3	751.26	-71.5	13.2	<12	125	< 300	P
-1	748.92	-61.7	751.26	-72.1	10.4	<12	N/A	< 300	P
-2	748.92	-60	751.26	-73.8	13.8	<12	39	< 300	P
-3	748.92	-64	751.26	-74.9	10.9	<12	N/A	< 300	P
-4	748.92	-63.4	751.26	-75.1	11.7	<12	N/A	< 300	P
-5	748.92	-61	751.26	-75.8	14.8	<12	123	< 300	P

Oscillation Mitigation – Downlink Common Donor Port 1 to Server Port 4									
Band	869 - 894 MHz								
Test Signal Type	CDMA								
Variable Attenuator Setting	Oscillations and Power Levels				Margin	Limit	Time to Mitigate Oscillation	Mitigation Time Limit	Pass / Fail
	Freq.	Level	Freq.	Level					
dB	MHz	dBm	MHz	dBm	dB	dB	sec	sec	
+5	876.87	-57.4	874.96	-68.1	10.7	<12	N/A	< 300	P
+4	876.87	-55.9	874.96	-67.3	11.4	<12	N/A	< 300	P
+3	876.87	-56.2	874.96	-68.9	12.7	<12	36	< 300	P
+2	876.87	-59.9	874.96	-70.8	10.9	<12	N/A	< 300	P
+1	876.87	-59.3	874.96	-70.7	11.4	<12	N/A	< 300	P
+0	876.87	-57.3	874.96	-71.3	14	<12	85	< 300	P
-1	876.87	-63.9	874.96	-73.8	9.9	<12	N/A	< 300	P
-2	876.87	-62.3	874.96	-73.9	11.6	<12	N/A	< 300	P
-3	876.87	-60.7	874.96	-74	13.3	<12	20	< 300	P
-4	876.87	-65.9	874.96	-76.3	10.4	<12	N/A	< 300	P
-5	876.87	-65.1	874.96	-76.8	11.7	<12	N/A	< 300	P

Radiated Spurious (with modem TX on)

Engineer: Greg Corbin

Test Date: 6/2/2019

Test Procedure

The EUT was tested in a semi-anechoic chamber with the turntable set 3m from the receiving antenna. A spectrum analyzer was used to verify that the EUT met the requirements for Radiated Emissions. The EUT was tested by rotating it 360 degrees with the antenna in both the vertical and horizontal orientation while raised from 1 to 4 meters to ensure that the signal levels were maximized. All cable and antenna correction factors were input into the spectrum analyzer ensuring an accurate measurement in ERP/EIRP with the resultant power in dBm. A signal generator was used to provide a CW signal centered in each operational uplink and downlink band. The EUT output was terminated into a 50 Ohm non-radiating load.

For each band, the spurious emissions were measured from 30 MHz to the 10th Harmonic of the band being investigated.

The internal cellular modem was powered on and transmitting at maximum power in the uplink direction at the frequency listed in the table.

Note: the cellular modem only transmits in the uplink direction, so no downlink tests are impacted by the cellular modem transmitting.

For all UL tests, there was no difference with the modem on or off, so all UL Radiated Spurious test data is recorded with the modem on and transmitting at full power in the band being recorded.

To verify modem was transmitting, installed temporary antenna at dedicated port output and observed modem transmitting on spectrum analyzer

Signal Paths measured for Radiated Spurious

Radiated Spurious							
Dedicated Ports					Common Ports		
U/L					U/L		
B12	B13	B5	B4	B25	B12	B13	B5
S4	S4	S4	S4	S4	S4	S4	S4
D/L					D/L		
B12	B13	B5	B4	B25	B12	B13	B5
D3	D3	D2	D1	D1	D3	D1	D1

Note: Port listed is signal injection port.

Frequency Band (MHz)	Cellular modem Frequency (MHz)
698 - 716	704
776 - 787	784
824 - 849	828
1710 - 1755	1725
1850 - 1910	1888

The following formula was used for calculating the limits:
Radiated Spurious Emissions Limit = $P1 - (43 + 10\text{Log}(P2)) = -13\text{dBm}$
P1 = power in dBm
P2 = power in Watts

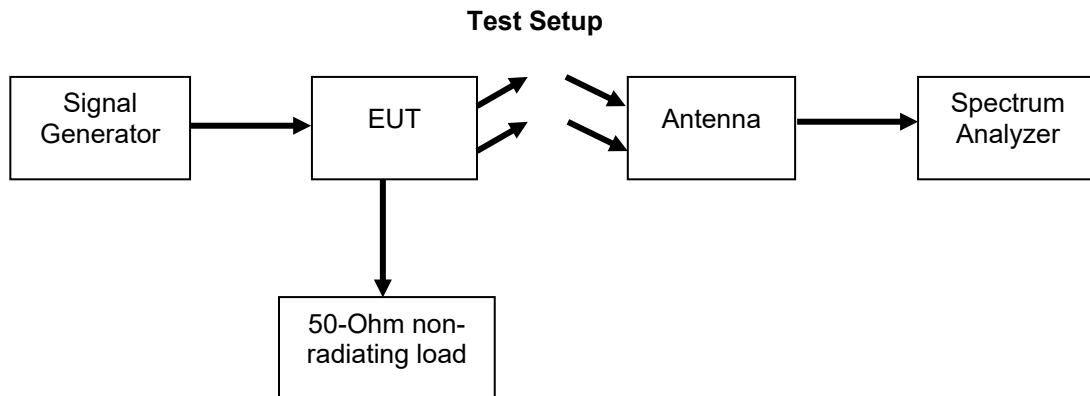

All emissions were lower than -13 dBm.

Annex J Radiated Spurious Emission

Refer to Annex J for Radiated Spurious Emission plots

Conducted Spurious Emissions with Modem Transmitting

Engineer: Greg Corbin

Test Date: 5-30-2019

Test Procedure

The EUT was connected to a spectrum analyzer through an attenuator, with the losses being input into the spectrum analyzer as a combination of reference level offset and correction factor as needed to ensure accurate readings. A signal generator was utilized to produce a 4.1 MHz AWGN signal operating at the maximum allowable power.

The conducted spurious emissions from 9 kHz to 10 times the highest tunable frequency for each operational band were measured (excluding the band defined by the Out of band emissions test). The emissions were plotted and the highest level was recorded in the summary table.

The internal cellular modem was powered on and transmitting at maximum power in the uplink direction at the frequency listed in the table.

Note: the cellular modem only transmits ion the uplink direction, so no downlink tests are impacted by the cellular modem transmitting.

Signal Paths measured for Conducted Spurious Emissions with Modem Transmitting

Conducted Spurious Emissions with Modem Transmitting							
Dedicated Ports					Common Ports		
U/L					U/L		
B12	B13	B5	B4	B25	B12	B13	B5
S4 to D3	S4 to D3	S4 to D2	S4 to D1	S4 to D1	S4 to D1	S4 to D1	S4 to D1

The following formulas are used for calculating the limits.

Conducted Spurious Emissions Limit = $P1 - (43 + 10\text{Log}(P2)) = -13 \text{ dBm}$

P1 = power in dBm

P2 = power in Watts

Test Setup

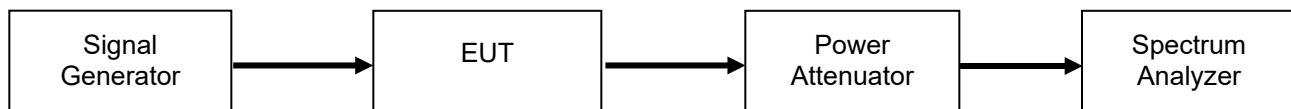

Uplink Test Results

Server Port 4 to Dedicated Donor Port

Frequency Band (MHz)	Cellular modem Frequency	Measured Frequency (MHz)	Measured Level (dBm)	Limit (dBm)	Result
698 - 716	704	716.9	-29.3	-13	Pass
776 - 787	784	787.1	-25.9	-13	Pass
824 - 849	828	851.9	-26.6	-13	Pass
1710 - 1755	1725	15201.5	-27.5	-13	Pass
1850 - 1910	1888	15504	-27.2	-13	Pass

Server Port 4 to Common Donor Port

Frequency Band (MHz)	Cellular modem Frequency	Measured Frequency (MHz)	Measured Level (dBm)	Limit (dBm)	Result
698 - 716	704	716.1	-32	-13	Pass
776 - 787	784	775.9	-29.8	-13	Pass
824 - 849	828	850	-27.6	-13	Pass

Annex K Conducted Spurious Emission with the cellular modem transmitting

Refer to Annex K for Conducted Spurious Emission plots with the cellular modem transmitting

Intermodulation with Modem Transmitting

Engineer: Greg Corbin

Test Date: 5-9-2019

Test Procedure

2 tests were performed for 3-tone intermodulation.

The first test was performed using 3 CW signals combined at the EUT input.

The internal modem was powered on but not transmitting.

The CW signals were spaced 300 kHz apart and centered at the peak of the operational band.

Attenuator, combiner, and cable insertion loss correction factors were input to either the signal generator or the spectrum analyzer as required to ensure that accurate measurements were recorded.

The input power was increased until the AGC level was reached. The input power was then set to 0.2 dB below the AGC level and intermodulation products were measured to ensure they were less than -19 dBm in a 3 kHz RBW.

The spectrum analyzer screenshot was captured and the highest-level intermodulation signal was recorded in the test summary table.

The input power was increased in 2 dB increments to 10 dB above the AGC threshold to verify the intermodulation products remain below the limit. During this test, the input power was not increased past the maximum allowed.

The intermodulation level with the input power 10 dB higher than the AGC threshold was recorded in the test summary table.

For the 2nd test, a two-tone test with the modem transmitting was performed. The 2 CW signals were centered at the peak of the passband.

The modem was tuned to a channel near the CW signals without masking the intermodulation signals.

Before setting the modem to transmit mode, a screen capture of the 2-tone intermodulation products was recorded with the input power set to 0.2 dB below the AGC threshold.

The modem was then set to transmit mode at the maximum power level and the intermodulation products were recorded along with the spectrum analyzer screen capture.

The input power was increased in 2 dB increments to 10 dB above the AGC threshold to verify the intermodulation products remain below the limit. During this test, the input power was not increased past the maximum allowed.

The intermodulation level with the input power 10 dB higher than the AGC threshold was recorded in the test summary table.

At no time during the test, did the intermodulation products exceed the -19 dBm limit.

For all tests an Average detector was used and the RBW was set to 3 kHz.

Measurement Summary

1. Measured 3 tone with 3 CW signals using 3 separate signal generators _0.2 dB below AGC
2. Measured 3 tone with 3 CW signals using 3 separate signal generators_ Pin + 10 dB
3. Measured 2 tone with modem TX off_0.2 dB below AGC
4. Measured 2 tone with modem TX On_0.2 dB below AGC
5. Measured 2 tone with Modem On_ Pin + 10 dB

Signal Paths measured for 3 Tone Intermodulation Test with Modem Transmitting

3 Tone Intermodulation Test with Modem Transmitting							
Dedicated Ports					Common Ports		
U/L					U/L		
B12	B13	B5	B4	B25	B12	B13	B5
S4 to D3	S4 to D3	S4 to D2	S4 to D1	S4 to D1	S4 to D1	S4 to D1	S4 to D1

3 Tone Intermodulation Test Setup

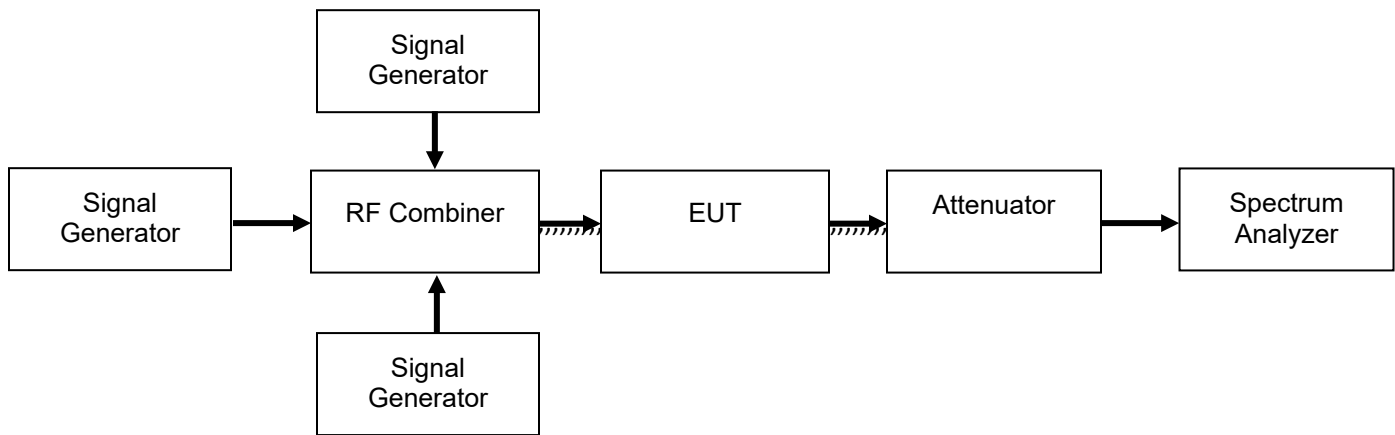

Intermodulation Test Results with 3 CW signals

Server Port 4 to Dedicated Donor Port

Uplink Band (MHz)	1 st Tone (MHz)	2 nd Tone (MHz)	3 rd Tone (MHz)	Intermodulation Level (dBm)	Limit (dBm)	Result (Pass / Fail)	Intermod Level with Input Power @ AGC + 10 dB	Result (Pass / Fail)
698 - 716	710.25	710.55	710.85	-20.4	-19	Pass	-21.9	Pass
776 - 787	778.35	778.65	778.95	-19.2	-19	Pass	-30.7	Pass
824 - 849	834.6	834.9	835.2	-24.4	-19	Pass	-22.5	Pass
1710 - 1755	1730.55	1730.85	1731.15	-19.9	-19	Pass	-20.8	Pass
1850 - 1915	1893.75	1894.04	1894.35	-20.7	-19	Pass	-22.0	Pass

Server Port 4 to Common Donor Port 1

Uplink Band (MHz)	1 st Tone (MHz)	2 nd Tone (MHz)	3 rd Tone (MHz)	Intermodulation Level (dBm)	Limit (dBm)	Result (Pass / Fail)	Intermod Level with Input Power @ AGC + 10 dB	Result (Pass / Fail)
698 - 716	710.15	710.45	710.75	-22.6	-19	Pass	-23.3	Pass
776 - 787	778.3	778.6	778.9	-20.0	-19	Pass	-31.2	Pass
824 - 849	834.55	834.85	835.15	-23.7	-19	Pass	-23.6	Pass

Intermodulation Test Results with 2 CW signals and Modem Transmitting

Server Port 4 to Dedicated Donor Port

Uplink Band (MHz)	1 st Tone (MHz)	2 nd Tone (MHz)	Modem Frequency (MHz)	Intermodulation Level (dBm)	Limit (dBm)	Result (Pass / Fail)	Intermod Level with Input Power @ AGC + 10 dB	Result (Pass / Fail)
698 - 716	710.25	710.85	704	-28.2	-19	Pass	-23.8	Pass
776 – 787	778.35	778.95	784	-30.5	-19	Pass	-20.9	Pass
824 – 849	834.6	835.2	828	-36.7	-19	Pass	-24.7	Pass
1710 – 1755	1730.55	1731.15	1725	-44.1	-19	Pass	-28.6	Pass
1850 – 1915	1893.75	1894.35	1893.15	-43.7	-19	Pass	-26.8	Pass

Server Port 4 to Common Donor Port 1

Uplink Band (MHz)	1 st Tone (MHz)	2 nd Tone (MHz)	Modem Frequency (MHz)	Intermodulation Level (dBm)	Limit (dBm)	Result (Pass / Fail)	Intermod Level with Input Power @ AGC + 10 dB	Result (Pass / Fail)
698 - 716	710.25	710.85	704	-30.5	-19	Pass	-25.4	Pass
776 – 787	778.3	778.9	784	-23.5	-19	Pass	-30.4	Pass
824 – 849	834.55	835.15	833.95	-35.9	-19	Pass	-26.7	Pass

Annex L 3 Tone Intermodulation

Refer to Annex L for 3 Tone Intermodulation Test Data

Isolation

Engineer: Greg Corbin

Test Date: 6/2/2019

Test Procedure

The EUT was connected as shown in Test Set-up.

For the uplink with switch in position 1 (dedicated ports), a CW signal at center frequency of the uplink band was injected into server port 1 with the input power set to just below the AGC Threshold.

The signal was measured at the wanted dedicated port output, and at the unwanted dedicated port outputs.

The difference in the amplitude of the signal at the wanted port and the signal at the unwanted ports is the isolation.

The test was repeated on the uplink with the switch set to position 2 (Common Port). The CW signal was injected into server port 1 and the wanted signal was measured at donor port 1 and the isolation was measured for donor ports 2 and 3.

For the downlink with switch in position 1 (dedicated ports), a CW signal at center frequency of the uplink band was injected into the dedicated donor port with the input power set to just below the AGC Threshold..

The wanted signal was measured at the server port 1 output. The unwanted signal was measured at the other 2 donor ports.

This test was repeated for the common port downlink path. The CW signal was injected into Donor port 1. The wanted signal was measured at the server port 1 output. The unwanted signal was measured at the donor port 2 and donor port 3.

This test was repeated for the signal paths shown in the table below.

Test Setup

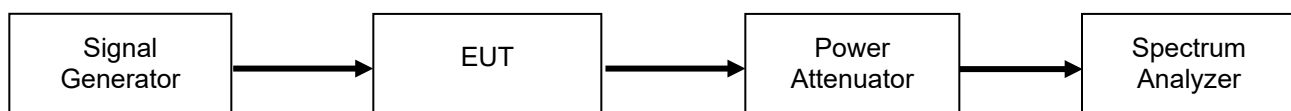

Signal Paths measured for the Isolation Test

Isolation_Uplink					
Dedicated_Switch Position 1			Common_Switch Position 2		
Inject Signal_Server Port 1			Inject Signal_Server Port 1		
Measure Isolation			Measure Isolation		
Band	Port	Port	Band	Port	Port
B12	D1	D2	B12	D2	D3
B13	D1	D2	B13	D2	D3
B5	D1	D3	B5	D2	D3
B4	D2	D3			
B25	D2	D3			

Isolation_Downlink					
Dedicated_Switch Position 1			Common_Switch Position 2		
Inject Signal_Dedicated Donor Port			Inject Signal_Donor Port 1		
Measure Isolation			Measure Isolation		
Band	Port	Port	Band	Port	Port
B12	D1	D2	B12	D2	D3
B13	D1	D2	B13	D2	D3
B5	D1	D3	B5	D2	D3
B4	D2	D3			
B25	D2	D3			

On the test data in Annex M the markers are assigned as follows:

Marker MR = wanted signal, M1 = unwanted signal at D1, M2 = unwanted signal at D2

The isolation was > 60 dB for all measurements

Annex M Isolation

Refer to Annex M for Isolation Test Data

Measurement Uncertainty

Measurement Uncertainty for Compliance Testing is listed in the table below.

The reported expanded uncertainty has been estimated at a 95% confidence level (k=2)

Measurement Type	Expanded Uncertainty
Conducted Emissions, AC Powerline	± 3.28 dB
Radiated Emissions_30 – 1000 MHz	± 4.82 dB
Radiated Emissions_1 – 18 GHz	± 5.73 dB
Frequency Error	± 22 Hz
Conducted RF Power	± 0.98 dB
Conducted Spurious Emission	± 2.49 dB
AC Voltage	± 2.3 %
DC Voltage	± 0.12 %
Temperature	± 1.0 deg C
Humidity	± 4.32 %

Test Equipment Utilized

Description	Manufacturer	Model #	CT Asset #	Last Cal Date	Cal Due Date
Horn Antenna	EMCO	3116	i00085	2/28/19	2/28/21
Bi-Log Antenna	Chase	CBL6111C	i00267	3/8/18	3/8/20
Horn Antenna	ARA	DRG-118/A	i00271	6/16/18	6/16/20
Humidity / Temp Meter	Newport	IBTHX-W-5	i00282	6/29/18	6/29/19
Spectrum Analyzer	Agilent	E4407B	i00331	12/4/18	12/4/19
EMI Analyzer	Agilent	E7405A	i00379	1/16/19	1/16/20
Signal Generator	Rohde & Schwarz	SMU200A	i00405	5/10/18	5/10/19**
Spectrum Analyzer	Textronix	RSA5126A	i00424	5/9/18	5/9/19**
3 Meter Semi-Anechoic Chamber	Panashield	3 Meter Semi-Anechoic Chamber	i00428	8/15/16	8/15/19
Signal Generator	Agilent	E4438C	i00457	10/15/18	10/15/19
Preamplifier	Miteq	AMF-6F-18004000-29-8P	i00461	N/A	N/A
Voltmeter	Fluke	179	i00488	4/24/19	4/24/20
Preamplifier	Miteq	AFS44 00101 400 23-10P-44	i00509	N/A	N/A

**60 day extension approved by QA manager

In addition to the above listed equipment standard RF connectors and cables were utilized in the testing of the described equipment. Prior to testing these components were tested to verify proper operation.

END OF TEST REPORT



Compliance Testing, LLC
Testing since 1963