



# Compliance Testing, LLC

Previously Flom Test Lab

EMI, EMC, RF Testing Experts Since 1963

toll-free: (866) 311-3268

fax: (480) 926-3598

<http://www.ComplianceTesting.com>

[info@ComplianceTesting.com](mailto:info@ComplianceTesting.com)

## Test Report

Prepared for: Wilson Electronics, LLC

Model: 460036

Description: Quint Band Signal Booster

Serial Number: 17, 19

FCC ID: PWO460036

To

FCC Part 20

Date of Issue: December 19, 2016

On the behalf of the applicant:

Wilson Electronics, LLC  
3301 E Deseret Drive  
St. George, UT 84790

To the attention of:

Erin Elder, Senior IP and Compliance Engineer  
Ph: (435)673-5021  
Email: [eelder@wilsonelectronics.com](mailto:eelder@wilsonelectronics.com)

Prepared By  
Compliance Testing, LLC  
1724 S. Nevada Way  
Mesa, AZ 85204  
(480) 926-3100 phone / (480) 926-3598 fax  
[www.compliancetesting.com](http://www.compliancetesting.com)  
Project No: p16a0018

**Greg Corbin**  
Project Test Engineer

This report may not be reproduced, except in full, without written permission from Compliance Testing.  
All results contained herein relate only to the sample tested.

### Test Report Revision History

Revision	Date	Revised By	Reason for Revision
1.0	December 1, 2016	Greg Corbin	Original Document

## Table of Contents

<b><u>Description</u></b>	<b><u>Page</u></b>
Standard Test Conditions and Engineering Practices	5
Test Result Summary	6
Authorized Frequency Band	7
Maximum Power and Gain	8
Intermodulation	11
Out-of-Band Emissions	12
Conducted Spurious Emissions	16
Noise Limits	19
Uplink Inactivity	22
Variable Gain	23
Occupied Bandwidth	25
Anti-Oscillation	26
Oscillation Mitigation	28
Radiated Spurious	34
Test Equipment Utilized	35

**ILAC / A2LA**

Compliance Testing, LLC, has been accredited in accordance with the recognized International Standard ISO/IEC 17025:2005. This accreditation demonstrates technical competence for a defined scope and the operation of a laboratory quality management system (refer to the joint ISO-ILAC-IAF Communiqué dated January 2009).

The tests results contained within this test report all fall within our scope of accreditation, unless noted below.

Please refer to <http://www.compliancetesting.com/labscope.html> for current scope of accreditation.

Testing Certificate Number: **2152.01**



**FCC Site Reg. #349717**

**IC Site Reg. #2044A-2**

**Non-accredited tests contained in this report:**

**N/A**

## Test and Measurement Data

Sub-part  
 2.1033(c)(14):

All tests and measurement data shown were performed in accordance with FCC Rules and Regulations, Part 2, Subpart J and the following individual Parts: 20.21 in conjunction with latest version of KDB 935210.

## Standard Test Conditions and Engineering Practices

Except as noted herein, the following conditions and procedures were observed during the testing:

In accordance with ANSI/C63.4-2014, and unless otherwise indicated in the specific measurement results, the ambient temperature of the actual EUT was maintained within the range of 10° to 40°C (50° to 104°F), unless the particular equipment requirements specified testing over a different temperature range. Also, unless otherwise indicated, the humidity levels were in the range of 10% to 90% relative humidity.

Environmental Conditions		
Temp (°C)	Humidity (%)	Pressure (mbar)
18.5 – 26.0	26.9 – 47.8	961.2 – 977.7

Measurement results, unless otherwise noted, are worst-case measurements.

## EUT Description

**Model:** 460036

**Description:** Quint Band Signal Booster

**Firmware:** A430036A

**Software:** A460036

**Serial Number:** 17, 19

### Additional Information:

The EUT is an **In-Building**, bi-directional amplifier for the boosting of cellular phone signals and data communication devices.

The following frequency bands and emission types are utilized.

Frequency Band (MHz)					
<b>Uplink</b>	698 - 716	776 - 787	824 - 849	1850 - 1910	1710 – 1755
<b>Downlink</b>	728 - 746	746 - 757	869 - 894	1930 - 1990	2110 - 2155
<b>Modulation Type</b>	LTE		GSM, CDMA, EDGE, HSPA, EVDO, LTE		CDMA, HSPA, LTE, EDGE, EVDO

Emission Designators					
CDMA	HSPA	LTE	EVDO	EDGE	GSM
F9W	F9W	G7D	F9W	G7W	GXW

The modulation types and emission designators listed in the tables represent the modulations that the cell phone providers use for each frequency band. GSM, CDMA, and WCDMA represent all the modulation types (phase and amplitude or a combination thereof) utilized within the industry. EDGE, HSPA, LTE etc. are all protocols or multiplexing techniques using the base modulations.

## EUT Operation during Tests

The EUT was in a normal operating condition with all external attenuation set to 0 dB.

## Test Result Summary

Specification	Test Name	Pass, Fail, N/A	Comments
20.21(e)(3)	Authorized Frequency Band	Pass	
20.21(e)(8)(i)(B) 20.21(e)(8)(i)(C) 20.21(e)(8)(i)(D)	Maximum Power and Gain	Pass	
20.21(e)(8)(i)(F)	Intermodulation	Pass	
20.21(e)(8)(i)(E)	Out-of-Band Emissions	Pass	
2.1051 22.917(a) 24.238(a) 27.53(c) 27.53(f) 27.53(g) 27.53(h)	Conducted Spurious Emissions	Pass	
20.21(e)(8)(i)(A)	Noise Limits	Pass	
20.21(e)(8)(i)(I)	Uplink Inactivity	Pass	
20.21(e)(8)(i)(C)(1) 20.21(e)(8)(i)(H) 20.21(e)(8)(i)(C)(2)(i) (Fixed)	Variable Gain	Pass	
2.1049	Occupied Bandwidth	Pass	
20.21(e)(8)(ii)(A)	Anti - Oscillation	Pass	
2.1053	Radiated Spurious	Pass	
20.21(e)(8)(i)(B)	Spectrum Block Filtering	N/A	This only applies to devices utilizing spectrum block filtering

**Authorized Frequency Band**

**Engineer:** Greg Corbin

**Test Date:** 11/16/2016

**Test Procedure**

The EUT was connected to a spectrum analyzer through an attenuator with the losses being input into the spectrum analyzer as a combination of reference level offset and correction factor as needed to ensure accurate readings. A signal generator was utilized to produce a CW input signal tuned to the center channel of the operational band. The RF input level was increased to a point just prior to the AGC being in control of the power. The Signal generator was set to sweep across 2X the operational band of the EUT while the spectrum analyzer was set to MAX HOLD. Two markers were placed at the edges of the operational band and a third marker was placed at the highest point within the band no closer than 2.5 MHz from the band edge.

**Test Setup**

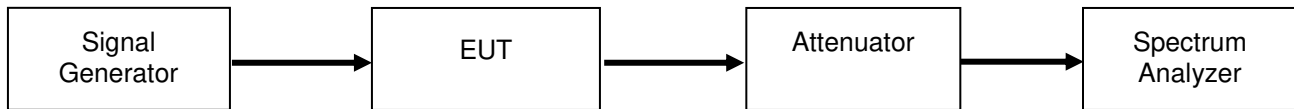

**Refer to Annex A for Authorized Frequency Band plots.**

## Maximum Power and Gain

**Engineer:** Greg Corbin

**Test Date:** 11/16/2016

### Test Procedure

The EUT was connected to a spectrum analyzer through an attenuator with the losses being input into the spectrum analyzer as a combination of reference level offset and correction factor as needed to ensure accurate readings. The spectrum analyzer and signal generator were tuned to the frequency with the highest power level in the band, as determined by the Authorized Frequency Band test. The RF input level was increased to a point just prior to the AGC being in control of the power for both pulsed single time slot GSM modulation and 4.1 MHz AWGN modulation. The maximum power was measured and verified to meet the minimum and maximum levels allowed, with the maximum gain being computed from these values. The uplink and downlink gain under each condition were verified to be within 9 dB of each other.

The input level was incremented in 2 dB steps up to the maximum input level for the EUT. The output power was recorded at the maximum input level. If the EUT shutdown before the maximum input level was reached, the input level was reduced to 1 dB before the EUT shutdown and the input and output levels were recorded.

For Fixed installations the following formula was used for calculating the gain limits.

$$\text{Gain Limit (dB)} = 6.5 \text{ dB} + 20\text{Log}(F_{\text{MHz}})$$

$F_{\text{MHz}}$  is the uplink mid-band frequency with the downlink gain limit being equivalent to the paired Uplink band gain limit.

### Test Setup

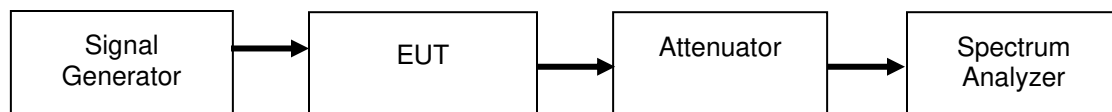

### Uplink Power Test Results

Frequency Band (MHz)	Input Level (dBm)	Output Power (dBm)	Lower Limit (dBm)	Upper Limit (dBm)	Antenna Gain (dBi)	EIRP (dBm)	Result
698 - 716 MHz Pulsed GSM	-36.7	25.3	17	30	4.5	29.8	Pass
698 - 716 MHz AWGN	-39.0	22.5	17	30	4.5	27.0	Pass
776 - 787 MHz Pulsed GSM	-37.5	25.7	17	30	4.2	29.9	Pass
776 - 787 MHz AWGN	-39.1	22.4	17	30	4.2	26.6	Pass
824 - 849 MHz Pulsed GSM	-40.0	24.5	17	30	4.9	29.4	Pass
824 - 849 MHz AWGN	-43.4	20.5	17	30	4.9	25.4	Pass
1710 - 1755 MHz Pulsed GSM	-41.1	26.1	17	30	3.81	29.9	Pass
1710 - 1755 MHz AWGN	-46.7	21.5	17	30	3.81	25.3	Pass
1850 - 1910 MHz Pulsed GSM	-43.7	25.1	17	30	4.74	29.8	Pass
1850 - 1910 MHz AWGN	-45.9	23.1	17	30	4.74	27.8	Pass



### Downlink Power Test Results

Frequency Band (MHz)	Input Level (dBm)	Output Power (dBm)	Upper Limit (dBm)	Antenna Gain (dBi)	EIRP (dBm)	Result
728 - 746 MHz Pulsed GSM	-47.2	15.5	17	-0.8	14.7	Pass
728 - 746 MHz AWGN	-47.5	15.2	17	-0.8	14.4	Pass
746 - 757 MHz Pulsed GSM	-47.3	14.9	17	-1.12	13.78	Pass
746 - 757 MHz AWGN	-47.6	14.6	17	-1.12	13.48	Pass
869 - 894 MHz Pulsed GSM	-48.8	15.1	17	-0.77	14.33	Pass
869 - 894 MHz AWGN	-49.0	14.8	17	-0.77	14.03	Pass
1930 - 1990 MHz Pulsed GSM	-55.0	15.4	17	-0.1	15.3	Pass
1930 - 1990 MHz AWGN	-55.8	14.6	17	-0.1	14.5	Pass
2110 - 2155 MHz Pulsed GSM	-52.7	15.3	17	1.47	16.77	Pass
2110 - 2155 MHz AWGN	-56.3	11.9	17	1.47	13.37	Pass

### Uplink and Downlink Gain Test Results

Modulation	Uplink Frequency (MHz)	Downlink Frequency (MHz)	Uplink Gain (dB)	Uplink Limit (dB)	Downlink Gain (dB)	Downlink Limit (dB)	Delta (dB)	Limit (dB)	Margin (dB)
Pulsed GSM	711.688	744.5	62.0	63.5	62.7	63.5	0.7	9	-8.3
AWGN	711.688	744.5	61.5	63.5	62.7	63.5	1.2	9	-7.8
Pulsed GSM	779.063	747.125	63.2	64.4	62.2	64.4	1	9	-8
AWGN	779.063	747.125	61.5	64.4	62.2	64.4	0.7	9	-8.3
Pulsed GSM	833.813	879.875	64.5	64.9	63.9	64.9	0.6	9	-8.4
AWGN	833.813	879.875	63.9	64.9	63.8	64.9	0.1	9	-8.9
Pulsed GSM	1754.775	2140.2	67.2	71	68.0	71	0.8	9	-8.2
AWGN	1754.775	2140.2	68.2	71	68.2	71	0	9	-9
Pulsed GSM	1860.88	1968.25	68.8	72	70.4	72	1.6	9	-7.4
AWGN	1860.88	1968.25	69.0	72	70.4	72	1.4	9	-7.6

### Maximum Input Power Test

Frequency Band (MHz)	Maximum Input Level (dBm)	Output Power at Maximum Input Power (dBm)	Lower Limit (dBm)	Upper Limit (dBm)	Result
698 - 716 MHz Pulsed GSM	0	23.2	17	30	Pass
698 - 716 MHz AWGN	0	22.3	17	30	Pass
776 - 787 MHz Pulsed GSM	0	25.6	17	30	Pass
776 - 787 MHz AWGN	0	23.1	17	30	Pass
824 - 849 MHz Pulsed GSM	0	22.0	17	30	Pass
824 - 849 MHz AWGN	0	20.1	17	30	Pass
1710 - 1755 MHz Pulsed GSM	0	25.5	17	30	Pass
1710 - 1755 MHz AWGN	0	21.2	17	30	Pass
1850 - 1910 MHz Pulsed GSM	0	23.7	17	30	Pass
1850 - 1910 MHz AWGN	0	23.2	17	30	Pass

Frequency Band (MHz)	Maximum Input Level (dBm)	Output Power at Maximum Input Power (dBm)	Upper Limit (dBm)	Result
728 - 746 MHz Pulsed GSM	-20	14.3	17	Pass
728 - 746 MHz AWGN	-20	15.0	17	Pass
746 - 757 MHz Pulsed GSM	-20	14.7	17	Pass
746 - 757 MHz AWGN	-20	14.7	17	Pass
869 - 894 MHz Pulsed GSM	-20	13.0	17	Pass
869 - 894 MHz AWGN	-20	15.7	17	Pass
1930 - 1990 MHz Pulsed GSM	-20	15.6	17	Pass
1930 - 1990 MHz AWGN	-20	14.1	17	Pass
2110 - 2155 MHz Pulsed GSM	-20	14.7	17	Pass
2110 - 2155 MHz AWGN	-20	11.7	17	Pass

## Intermodulation

**Engineer:** Greg Corbin

**Test Date:** 11/16/2016

### Test Procedure

The EUT was connected to a spectrum analyzer through an attenuator. Two signal generators were utilized to produce two CW signals 600 kHz apart and centered in the operational band. Attenuator and cable insertion loss correction factors were input to either the signal generator or the spectrum analyzer as required to ensure that accurate measurements were recorded. The input power was set at the maximum allowable power and the RMS intermodulation products were measured to ensure they were less than -19 dBm in a 3 kHz RBW. The uplink and downlink intermodulation products were plotted, with the levels being listed in the summary tables.

The input power was increased in 2 dB increments to 10 dB above the AGC threshold and to verify the intermod products remain below the limit. During this test, the input power was not increased past the maximum allowed. The Intermodulation level was recorded

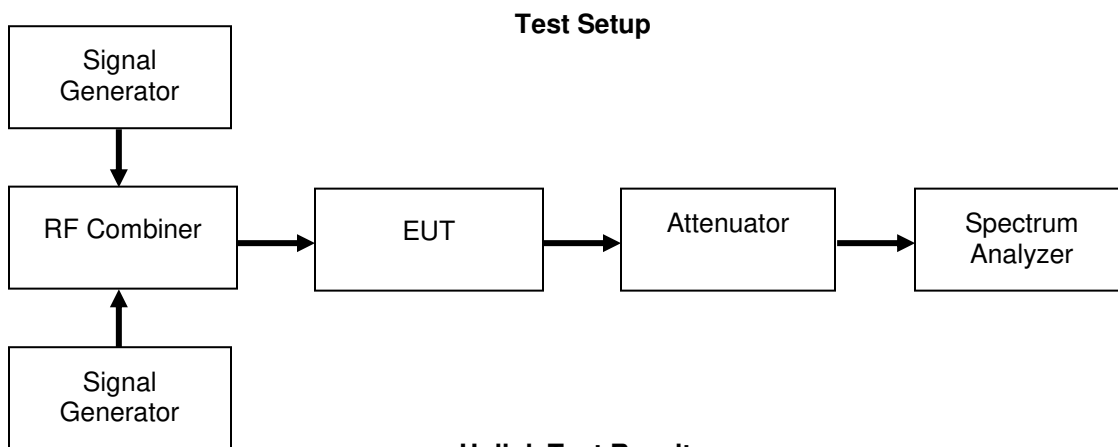

### Uplink Test Results

Frequency Band (MHz)	Intermodulation Level (dBm)	Limit (dBm)	Result	Intermod Level with Input Power @ AGC + 10 dB	Result (Pass / Fail)
698 - 716 MHz	-19.6	-19	Pass	-20	Pass
776 - 787 MHz	-19.3	-19	Pass	-20.9	Pass
824 - 849 MHz	-19.6	-19	Pass	-19.9	Pass
1710 - 1755 MHz	-20.21	-19	Pass	-20.3	Pass
1850 - 1910 MHz	-23.8	-19	Pass	-24.8	Pass

### Downlink Test Results

Frequency Band (MHz)	Intermodulation Level (dBm)	Limit (dBm)	Result	Intermod Level with Input Power @ AGC + 10 dB	Result (Pass / Fail)
728 - 746 MHz	-29.9	-19	Pass	-29.9	Pass
746 - 757 MHz	30.8	-19	Pass	30.8	Pass
869 - 894 MHz	-33.4	-19	Pass	-33.4	Pass
1930 - 1990 MHz	-37.3	-19	Pass	-37.3	Pass
2110 - 2155 MHz	-20.5	-19	Pass	-20.5	Pass

Refer to Annex B for Intermodulation Test plots

## Out-of-Band Emissions

**Engineer:** Greg Corbin

**Test Date:** 11/10/2016

### Test Procedure

The EUT was connected to a spectrum analyzer through an attenuator with the losses being input into the spectrum analyzer as a combination of reference level offset and correction factor in order to ensure accurate readings. A signal generator was utilized to produce the following signals: GSM, CDMA, and WCDMA. The signal generator was tuned to the lowest allowable upper and lower channel within the EUT operational band for each respective modulation type. The RF input level was increased to a point just prior to the AGC being in control of the power. For each modulation type the Out of Band Emissions were measured to ensure they met the limits.

The following formula was used for calculating the limits:

$$\text{Limit} = P1 - 6 - (43 + 10\text{Log}(P2)) = -19\text{dBm}$$

P1 = power in dBm

P2 = power in Watts

The input power was increased in 2 dB steps up to the maximum input power for the booster being tested. The OOB limit was verified to stay below the OOB Limit. This was recorded as Pass / Fail in the OOB tables.

### Test Setup



### GSM Uplink Test Results

Frequency Band (MHz)	Band Edge	Measured Level (dBm)	Limit (dBm)	Result	Oobe Below Limit at Max Input Power (Yes / No)
698 - 716	Lower	-30.5	-19	Pass	Yes
698 - 716	Upper	-28.7	-19	Pass	Yes
776 - 787	Lower	-29.4	-19	Pass	Yes
776 - 787	Upper	-28.9	-19	Pass	Yes
824 - 849	Lower	-36.8	-19	Pass	Yes
824 - 849	Upper	-36.9	-19	Pass	Yes
1710 - 1755	Lower	-39	-19	Pass	Yes
1710 - 1755	Upper	-34.8	-19	Pass	Yes
1850 - 1910	Lower	-33	-19	Pass	Yes
1850 - 1910	Upper	-76.3	-19	Pass	Yes

### CDMA Uplink Test Results

Frequency Band (MHz)	Band Edge	Measured Level (dBm)	Limit (dBm)	Result	Oobe Below Limit at Max Input Power (Yes / No)
698 - 716	Lower	-41.9	-19	Pass	Yes
698 - 716	Upper	-41.3	-19	Pass	Yes
776 - 787	Lower	-46.4	-19	Pass	Yes
776 - 787	Upper	-45.7	-19	Pass	Yes
824 - 849	Lower	-37.9	-19	Pass	Yes
824 - 849	Upper	-44.3	-19	Pass	Yes
1710 - 1755	Lower	-46.9	-19	Pass	Yes
1710 - 1755	Upper	-41.5	-19	Pass	Yes
1850 - 1910	Lower	-34.7	-19	Pass	Yes
1850 - 1910	Upper	-50.1	-19	Pass	Yes

### WCDMA Uplink Test Results

Frequency Band (MHz)	Band Edge	Measured Level (dBm)	Limit (dBm)	Result	Oobe Below Limit at Max Input Power (Yes / No)
698 - 716	Lower	-42.8	-19	Pass	Yes
698 - 716	Upper	-41.2	-19	Pass	Yes
776 - 787	Lower	-45	-19	Pass	Yes
776 - 787	Upper	-45.8	-19	Pass	Yes
824 - 849	Lower	-37.4	-19	Pass	Yes
824 - 849	Upper	-42.1	-19	Pass	Yes
1710 - 1755	Lower	-43.5	-19	Pass	Yes
1710 - 1755	Upper	-41.6	-19	Pass	Yes
1850 - 1910	Lower	-37.8	-19	Pass	Yes
1850 - 1910	Upper	-45.1	-19	Pass	Yes

### GSM Downlink Test Results

Frequency Band (MHz)	Band Edge	Measured Level (dBm)	Limit (dBm)	Result	Oobe Below Limit at Max Input Power (Yes / No)
728 - 746 MHz	Lower	-36.2	-19	Pass	Yes
728 - 746 MHz	Upper	-30.5	-19	Pass	Yes
746 - 757 MHz	Lower	-41.7	-19	Pass	Yes
746 - 757 MHz	Upper	-35	-19	Pass	Yes
869 - 894 MHz	Lower	-42.1	-19	Pass	Yes
869 - 894 MHz	Upper	-41.9	-19	Pass	Yes
1930 - 1990 MHz	Lower	-53.3	-19	Pass	Yes
1930 - 1990 MHz	Upper	-66.1	-19	Pass	Yes
2110 - 2155 MHz	Lower	-41.1	-19	Pass	Yes
2110 - 2155 MHz	Upper	-41.8	-19	Pass	Yes

### CDMA Downlink Test Results

Frequency Band (MHz)	Band Edge	Measured Level (dBm)	Limit (dBm)	Result	Oobe Below Limit at Max Input Power (Yes / No)
728 - 746 MHz	Lower	-53.3	-19	Pass	Yes
728 - 746 MHz	Upper	-47.3	-19	Pass	Yes
746 - 757 MHz	Lower	-48.2	-19	Pass	Yes
746 - 757 MHz	Upper	-53.5	-19	Pass	Yes
869 - 894 MHz	Lower	-59.3	-19	Pass	Yes
869 - 894 MHz	Upper	-56.1	-19	Pass	Yes
1930 - 1990 MHz	Lower	-63.1	-19	Pass	Yes
1930 - 1990 MHz	Upper	-58.6	-19	Pass	Yes
2110 - 2155 MHz	Lower	-44.7	-19	Pass	Yes
2110 - 2155 MHz	Upper	-43.1	-19	Pass	Yes

### WCDMA Downlink Test Results

Frequency Band (MHz)	Band Edge	Measured Level (dBm)	Limit (dBm)	Result	Oobe Below Limit at Max Input Power (Yes / No)
728 - 746 MHz	Lower	-52.7	-19	Pass	Yes
728 - 746 MHz	Upper	-49.9	-19	Pass	Yes
746 - 757 MHz	Lower	-49.8	-19	Pass	Yes
746 - 757 MHz	Upper	-53.7	-19	Pass	Yes
869 - 894 MHz	Lower	-56.2	-19	Pass	Yes
869 - 894 MHz	Upper	-54.7	-19	Pass	Yes
1930 - 1990 MHz	Lower	-56.2	-19	Pass	Yes
1930 - 1990 MHz	Upper	-53.2	-19	Pass	Yes
2110 - 2155 MHz	Lower	-42.1	-19	Pass	Yes
2110 - 2155 MHz	Upper	-41.5	-19	Pass	Yes

Refer to Annex C for Out of Band Emission plots

## Conducted Spurious Emissions

**Engineer:** Greg Corbin

**Test Date:** 11/11/2016

### Test Procedure

The EUT was connected to a spectrum analyzer through an attenuator, with the losses being input into the spectrum analyzer as a combination of reference level offset and correction factor as needed to ensure accurate readings. A signal generator was utilized to produce a 4.1 MHz AWGN signal operating at the maximum allowable power. The conducted spurious emissions from 9 kHz to 10 times the highest tunable frequency for each operational band were measured (excluding the band defined by the Out of band emissions test). The emissions were plotted and the highest level was recorded in the summary table.

The following formulas are used for calculating the limits.

Conducted Spurious Emissions Limit =  $P1 - (43 + 10\text{Log}(P2)) = -13 \text{ dBm}$

P1 = power in dBm

P2 = power in Watts

### Test Setup

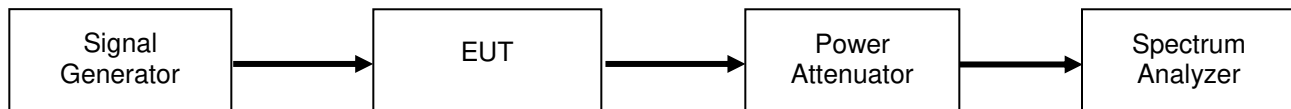

### Uplink Test Results

Frequency Band (MHz)	Measured Frequency (MHz)	Measured Level (dBm)	Limit (dBm)	Result
698 - 716	1755.4	-30.4	-13	Pass
776 - 787	1862.7	-29.8	-13	Pass
824 - 849	1880.5	-30	-13	Pass
1710 - 1755	1883.1	-29.1	-13	Pass
1850 - 1910	1763.5	-28.8	-13	Pass

### Downlink Test Results

Frequency Band (MHz)	Measured Frequency (MHz)	Measured Level (dBm)	Limit (dBm)	Result
728 - 746	2138.9	-29.6	-13	Pass
746 - 757	1961.2	-29.8	-13	Pass
869 - 894	1965.7	-29.3	-13	Pass
1930 - 1990	15905.8	-29.1	-13	Pass
2110 - 2155	21992.3	-27.5	-13	Pass



For the 746 – 758 downlink and 776 – 788 Uplink bands of operation, the following additional spurious emissions requirements apply.

**FCC 27.53(c)**

For operations in the 746-758 MHz band and the 776-788 MHz band, the power of any emission outside the licensee's frequency band(s) of operation shall be attenuated below the transmitter power (P) within the licensed band(s) of operation, measured in watts, in accordance with the following:

(3) On all frequencies between 763-775 MHz and 793-805 MHz, by a factor not less than  $76 + 10 \log (P)$  dB in a 6.25 kHz band segment, for base and fixed stations;

**776 – 787 MHz Uplink Band**

Spurious Frequency Range (MHz)	Measured Frequency (MHz)	Measured Value (dBm)	RBW (kHz)	Final Value (dBm)	Limit (dBm)	Margin (dB)
763 – 775	774.858	-53.1	6.25	-53.10	-46	-7.10
793 – 805	793.033	-58.3	6.25	-58.30	-46	-12.30

**746 - 757 MHz Downlink Band**

Spurious Frequency Range (MHz)	Measured Frequency (MHz)	Measured Value (dBm)	RBW (kHz)	Final Value (dBm)	Limit (dBm)	Margin (dB)
763 – 775	763.286	-72.3	6.25	-72.30	-46	-26.30
793 – 805	795.083	-71.8	6.25	-71.80	-46	-25.80

**FCC 27.53(f)**

For operations in the 746-758 MHz, 775-788 MHz, and 805-806 MHz bands, emissions in the band 1559-1610 MHz shall be limited to -70 dBW/MHz equivalent isotropically radiated power (EIRP) for wideband signals, and -80 dBW EIRP for discrete emissions of less than 700 Hz bandwidth. For the purpose of equipment authorization, a transmitter shall be tested with an antenna that is representative of the type that will be used with the equipment in normal operation.

Since the limit is referenced to EIRP, the final data is computed using the Conducted Spurious Emission data and adding the BW correction factor plus the final gain/loss data from the antenna kitting information supplied by the manufacturer.

The Limit for discreet (narrowband) emissions is -80dBW (-50 dBm) in 700 MHz BW.  
 The Limit for (wideband Emissions) is -70 dBW (-40 dBm) in a 1 MHz BW.

**776 – 787 MHz Uplink Band**

Spurious Frequency Range (MHz)	Measured Frequency (MHz)	Measured Value (dBm)	RBW	Gain/Loss from Antenna Kitting Information (dB)	Final Value (dBm)	Limit (dBm)	Margin (dB)
1559 – 1610 (Wideband)	1575.172	-51.4	1 MHz	4.20	-47.20	-40	-7.20
1559 – 1610 (Narrowband)	1607.891	-82.1	700 Hz	4.20	-77.90	-50	-27.90

**746 - 757 MHz Downlink Band**

Spurious Frequency Range (MHz)	Measured Frequency (MHz)	Measured Value (dBm)	RBW	Gain/Loss from Antenna Kitting Information (dB)	Final Value (dBm)	Limit (dBm)	Margin (dB)
1559 – 1610 (Wideband)	1595.327	-50.7	1 MHz	-1.12	-51.82	-40	-11.82
1559 – 1610 (Narrowband)	1609.794	-79.8	700 Hz	-1.12	-80.92	-50	-30.92

Refer to Annex D for Conducted Spurious Emission plots.

## Noise Limits

**Engineer:** Greg Corbin

**Test Date:** 11/16/2016

## Test Procedure

The EUT was connected to a spectrum analyzer through an attenuator with the losses being input into the spectrum analyzer as a combination of reference level offset and correction factor as necessary to ensure that accurate readings were obtained. A series of three tests were performed: the maximum uplink and downlink noise, the variable noise for the uplink and downlink in the presence of a downlink signal, and the variable uplink noise timing. The detailed procedures from KDB 935210 D03 v04 were followed.

The following formulas are used for calculating the limits. Note – Downlink noise power limit is calculated with the center frequency of the associated uplink band.

Noise Power =  $-102.5 + \text{LOG}_{10}(\text{Band Center Frequency}) * 20$

Variable Noise =  $-103 \text{ dBm/MHz-RSSI}$

## Test Setup

### Maximum Noise Power

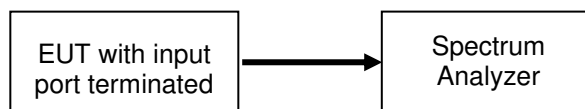

### Variable Uplink Noise Power and Timing

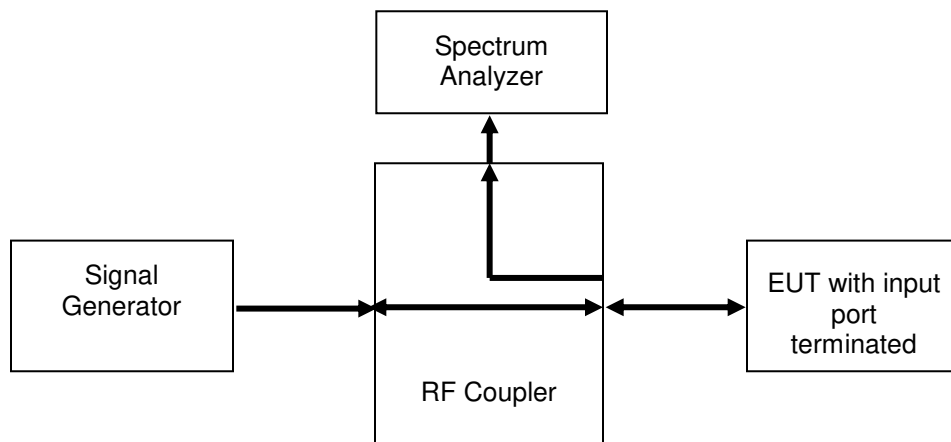

### Maximum Uplink Noise Test Results

Frequency Band (MHz)	Measured Noise (dBm)	Limit (dBm)	Margin (dB)	Result
698 - 716	-46.3	-45.5	-0.8	Pass
776 - 787	-45	-44.6	-0.4	Pass
824 - 849	-44.9	-44.1	-0.8	Pass
1710 - 1755	-38.3	-37.7	-0.6	Pass
1850 - 1910	-37.15	-37.0	-0.1	Pass

### Maximum Downlink Noise Test Results

Frequency Band (MHz)	Measured Noise (dBm)	Limit (dBm)	Margin (dB)	Result
728 - 746	-46.1	-45.5	-0.6	Pass
746 - 757	-47.1	-44.6	-2.5	Pass
869 - 894	-44.9	-44.1	-0.8	Pass
1930 - 1990	-37.6	-37.0	-0.6	Pass
2110 - 2155	-37.8	-37.7	-0.1	Pass

### Uplink Noise Timing Test Results

Frequency Band (MHz)	Measured Timing (Seconds)	Limit (Seconds)	Result
698 - 716	0.45	3.0	Pass
776 - 787	0.44	3.0	Pass
824 - 849	0.50	3.0	Pass
1710 - 1755	0.43	3.0	Pass
1850 - 1910	0.40	3.0	Pass

Refer to Annex E for Noise Limits and Uplink Noise Timing Plots



**Variable Uplink Noise Limit Test Results**

**698 - 716 MHz**

<b>RSSI (dBm)</b>	<b>Noise Limit (dBm)</b>	<b>Measured Noise (dBm)</b>	<b>Margin (dB)</b>
-47.0	-56.0	-57.1	-1.1
-37.0	-66.0	-67.1	-1.1
-36.0	-67.0	-68.2	-1.2
-35.0	-68.0	-69.2	-1.2
-33.0	-70.0	-70.9	-0.9
-31.0	-70.0	-71	-1.0

**776 - 787 MHz**

<b>RSSI (dBm)</b>	<b>Noise Limit (dBm)</b>	<b>Measured Noise (dBm)</b>	<b>Margin (dB)</b>
-39.0	-64.0	-64.6	-0.6
-38.0	-65.0	-65.8	-0.8
-36.0	-67.0	-67.4	-0.4
-34.0	-69.0	-69.8	-0.8
-33.0	-70.0	-70.5	-0.5
-32.0	-70.0	-70.7	-0.7

**824 - 849 MHz**

<b>RSSI (dBm)</b>	<b>Noise Limit (dBm)</b>	<b>Measured Noise (dBm)</b>	<b>Margin (dB)</b>
-37.0	-66.0	-67.5	-1.5
-36.0	-67.0	-68	-1.0
-35.0	-68.0	-69.2	-1.2
-34.0	-69.0	-70.2	-1.2
-33.0	-70.0	-70.6	-0.6
-32.0	-70.0	-71.6	-1.6

**1710 - 1755 MHz**

<b>RSSI (dBm)</b>	<b>Noise Limit (dBm)</b>	<b>Measured Noise (dBm)</b>	<b>Margin (dB)</b>
-84.0	-37.7	-38.1	-0.4
-83.0	-37.7	-38.1	-0.4
-82.0	-37.7	-38.1	-0.4
-81.0	-37.7	-38.1	-0.4
-45.0	-58.0	-59.5	-1.5
-41.0	-62.0	-63.2	-1.2

**1850 - 1910 MHz**

<b>RSSI (dBm)</b>	<b>Noise Limit (dBm)</b>	<b>Measured Noise (dBm)</b>	<b>Margin (dB)</b>
-71.0	-37.0	-37.6	-0.6
-69.0	-37.0	-37.5	-0.5
-36.0	-67.0	-67.6	-0.6
-35.0	-68.0	-68.5	-0.5
-34.0	-69.0	-69.3	-0.3
-33.0	-70.0	-70.6	-0.6

## Uplink Inactivity

**Engineer:** Greg Corbin

**Test Date:** 12/8/2016

### Test Procedure

The EUT was connected directly to a spectrum analyzer set to operate in the center of the EUT operational uplink and downlink bands. The span was set to 0 Hz with a sweep time of 330 seconds and MAX HOLD operation. The EUT was powered on and the time for the uplink to return to an inactive state was measured using the DELTA MARKER method to ensure that it was less than 300 seconds. The noise level after the return to an inactive state was less than -70 dBm/MHz.

### Test Setup

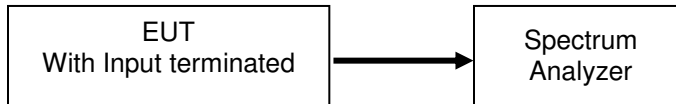

### Uplink Test Results

Frequency Band (MHz)	Measured Time (Seconds)	Limit (Seconds)	Result
698 - 716	223.2	300	Pass
776 - 787	249.5	300	Pass
824 - 849	224.8	300	Pass
1710 - 1755	226.4	300	Pass
1850 - 1910	219.8	300	Pass

Refer to Annex F for Uplink Inactivity Plots

**Variable Gain**
**Engineer:** Greg Corbin

**Test Date:** 11/17/2016

**Test Procedure**

The EUT was connected to a spectrum analyzer through an attenuator with the losses being input into the spectrum analyzer as a combination of reference level offset and correction factor in order to ensure accurate readings were obtained. The uplink gain in the presence of a downlink signal was measured for each operational uplink band using the detailed procedures from KDB 935210 D03 v04.

The following formula is used for calculating the limits:

$$\text{Variable Gain} = -34 \text{ dB} - \text{RSSI} + \text{MSCL}$$

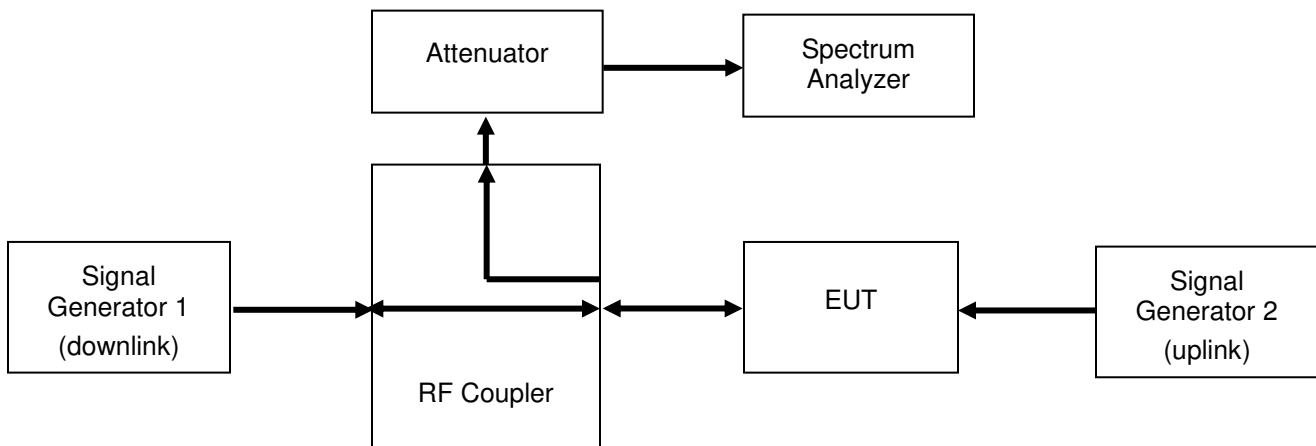
**Test Setup**

**Uplink Test Results**
**698 - 716 MHz**

RSSI (dBm)	MSCL (dB)	Gain Limit (dBm)	P(in) (dBm)	P(out) (dBm)	Gain (dB)	Margin (dB)
-27.0	38.5	31.5	-44.0	-17.2	26.8	-4.7
-26.0	38.5	30.5	-44.0	-18.1	25.9	-4.6
-25.0	38.5	29.5	-44.0	-19.1	24.9	-4.6
-24.0	38.5	28.5	-44.0	-20.1	23.9	-4.6
-21.0	38.5	25.5	-44.0	-23.1	20.9	-4.6
-20.0	38.5	24.5	-44.0	-24.1	19.9	-4.6

**776 - 787 MHz**

RSSI (dBm)	MSCL (dB)	Gain Limit (dBm)	P(in) (dBm)	P(out) (dBm)	Gain (dB)	Margin (dB)
-71.0	39.9	64.0	-44.1	16.9	61.0	-3.0
-65.0	39.9	64.0	-44.1	16.9	61.0	-3.0
-64.0	39.9	64.0	-44.1	16.9	61.0	-3.0
-60.0	39.9	64.0	-44.1	15.4	59.5	-4.5
-22.0	39.9	27.9	-44.1	-21.6	22.5	-5.4
-20.0	39.9	25.9	-44.1	-23.4	20.7	-5.2

**824 - 849 MHz**

RSSI (dBm)	MSCL (dB)	Gain Limit (dBm)	P(in) (dBm)	P(out) (dBm)	Gain (dB)	Margin (dB)
-74.0	39.9	65.0	-48.4	14.3	62.7	-2.3
-73.0	39.9	65.0	-48.4	14.3	62.7	-2.3
-72.0	39.9	65.0	-48.4	14.3	62.7	-2.3
-71.0	39.9	65.0	-48.4	14.3	62.7	-2.3
-51.0	39.9	56.9	-48.4	1.0	49.4	-7.5
-50.0	39.9	55.9	-48.4	0.0	48.4	-7.5

**1710 - 1755 MHz**

RSSI (dBm)	MSCL (dB)	Gain Limit (dBm)	P(in) (dBm)	P(out) (dBm)	Gain (dB)	Margin (dB)
-74.0	45.5	71.0	-51.7	13.9	65.6	-5.4
-73.0	45.5	71.0	-51.7	13.9	65.6	-5.4
-72.0	45.5	71.0	-51.7	13.9	65.6	-5.4
-71.0	45.5	71.0	-51.7	13.9	65.6	-5.4
-56.0	45.5	67.5	-51.7	2.0	53.7	-13.8
-54.0	45.5	65.5	-51.7	-0.3	51.4	-14.1

**1850 - 1910 MHz**

RSSI (dBm)	MSCL (dB)	Gain Limit (dBm)	P(in) (dBm)	P(out) (dBm)	Gain (dB)	Margin (dB)
-73.0	44.7	72.0	-50.9	17.6	68.5	-3.5
-72.0	44.7	72.0	-50.9	17.6	68.5	-3.5
-71.0	44.7	72.0	-50.9	17.6	68.5	-3.5
-68.0	44.7	72.0	-50.9	17.7	68.6	-3.4
-58.0	44.7	68.7	-50.9	6.7	57.6	-11.1
-57.0	44.7	67.7	-50.9	5.6	56.5	-11.2

**Uplink Gain Timing Test Results**

Frequency Band (MHz)	Measured Timing (Seconds)	Limit (Seconds)	Result
704 - 716	0.36	3.0	Pass
776 - 787	0.31	3.0	Pass
824 - 849	0.44	3.0	Pass
1710 - 1755	0.44	3.0	Pass
1850 - 1910	0.31	3.0	Pass

Refer to Annex G for Uplink Gain Timing Plots



## Occupied Bandwidth

**Engineer:** Greg Corbin

**Test Date:** 11/14/2016

### Test Procedure

The EUT was connected to a spectrum analyzer through an attenuator with the losses being input into the spectrum analyzer as a combination of reference level offset and correction factor as required to ensure that accurate readings were obtained. A signal generator was utilized to produce the following signals: GSM, CDMA, and WCDMA. The signal generator was tuned to the center channel of each of the EUT operational uplink and downlink bands with the RF level set at a point just prior to the AGC being in control of the power. For each modulation type, the input and output signal was measured and plotted to ensure that the signals were similar.

### Test Setup

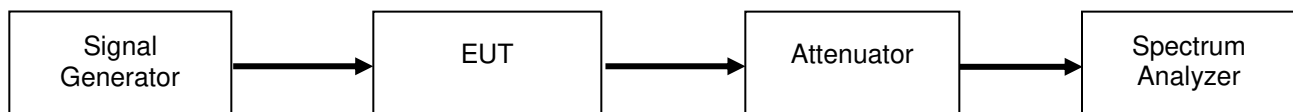

**Refer to Annex H for Occupied Bandwidth plots**

## Anti-Oscillation

**Engineer:** Greg Corbin

**Test Date:** 12/8/2016

### Test Procedure

The EUT was connected to a spectrum analyzer set for zero span mode. The EUT uplink and downlink were loop backed to each other through a selectable band pass filter and variable attenuator. The EUT uplink and downlink were tested to ensure that the presence of oscillation was detected and that the EUT output turned off within 300 mS for the Uplink and 1 second for the Downlink and remained off for 1 minute. The time was extended to capture how many times the unit attempted to restart.

### Test Setup

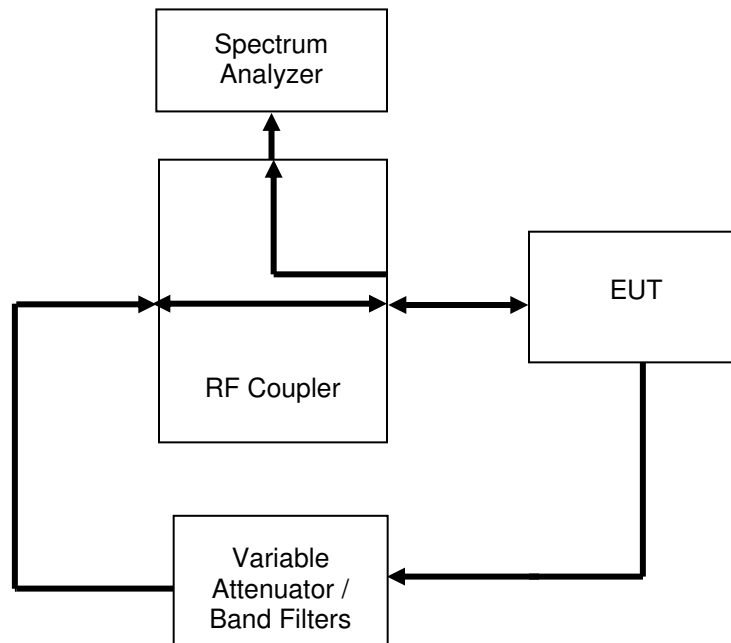

### Uplink Detection Time Test Results

Frequency Band (MHz)	Measured Time (mS)	Limit (mS)	Result
698 - 716	93.75	300	Pass
776 - 787	150	300	Pass
824 - 849	93.75	300	Pass
1710 - 1755	187.5	300	Pass
1850 - 1910	150	300	Pass

### Downlink Detection Time Test Results

Frequency Band (MHz)	Measured Time (mS)	Limit (mS)	Result
728 - 746	275	1000	Pass
746 - 757	287.5	1000	Pass
869 - 894	300	1000	Pass
1930 - 1990	175	1000	Pass
2110 - 2155	337.5	1000	Pass

Note: When the EUT detects an oscillation, it mitigates the oscillation to an acceptable level so there are no restarts as it mitigates to a reduced level and continues to operate.

#### Uplink Restart Time Test Results

Frequency Band (MHz)	Measured Time (S)	Limit (S)	Result
698 - 716	No restarts	≥60	Pass
776 - 787	No restarts	≥60	Pass
824 - 849	No restarts	≥60	Pass
1710 - 1755	No restarts	≥60	Pass
1850 - 1910	No restarts	≥60	Pass

#### Downlink Restart Time Test Results

Frequency Band (MHz)	Measured Time (S)	Limit (S)	Result
728 - 746	No restarts	≥60	Pass
746 - 757	No restarts	≥60	Pass
869 - 894	No restarts	≥60	Pass
1930 - 1990	No restarts	≥60	Pass
2110 - 2155	No restarts	≥60	Pass

#### Uplink Restart Count Test Results

Frequency Band (MHz)	Restarts	Limit	Result
698 - 716	0	≤5	Pass
776 - 787	0	≤5	Pass
824 - 849	0	≤5	Pass
1710 - 1755	0	≤5	Pass
1850 - 1910	0	≤5	Pass

#### Downlink Restart Count Test Results

Frequency Band (MHz)	Restarts	Limit	Result
728 - 746	0	≤5	Pass
746 - 757	0	≤5	Pass
869 - 894	0	≤5	Pass
1930 - 1990	0	≤5	Pass
2110 - 2155	0	≤5	Pass

Refer to Annex I for Oscillation Detection and Restart Timing Plots

**Oscillation Mitigation**

**Engineer:** Greg Corbin

**Test Date:** 12/8/2016

**Test Procedure**

The EUT was connected as shown per KDB 935210 D03 v04. The EUT was verified to mitigate the oscillation or shut down in the presence of an oscillation.

The total attenuation from output to input was set +5 dB higher than the gain for the band being tested.

For EUT's that do not shutdown, the peak oscillation was measured and the variable attenuator was reduced in 1 dB increments until the booster shuts off.

The frequency and amplitude of the highest oscillation and the lowest level in the valley next to the oscillation was recorded for each 1 dB step as required per the KDB.

For oscillations that exceeded the 12 dB limit, the time required for the booster to mitigate the oscillation to less than 12 dB was recorded.

If the booster mitigated the oscillation within the 300 second time limit, the time required to mitigate the oscillation was recorded along with the final level of the oscillation after mitigation.

**Note:** In all cases the booster mitigated the oscillation to less than 12 dB before the 300 second limit.

**Test Setup**

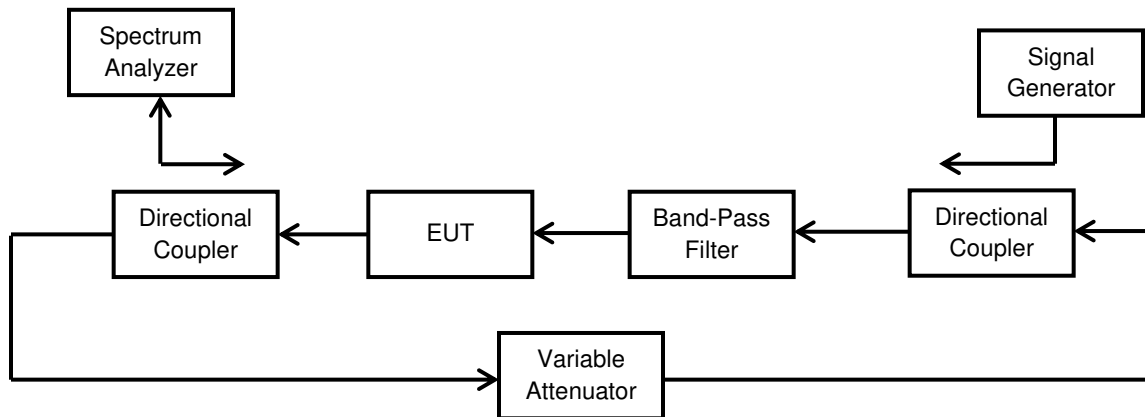

### Uplink Oscillation Mitigation Test Data

Oscillation Mitigation - Uplink									
Band	698 – 716 MHz								
Test Signal Type	CDMA								
Variable Attenuator Setting	Oscillations		Lowest Output Power Level		Margin	Limit	Time to Mitigate Oscillation	Mitigation Time Limit	Pass / Fail
	Freq.	Level	Freq.	Level					
dB	MHz	dBm	MHz	dBm	dB	dB	sec	sec	
+5	712.18	-56.6	710.17	-69.2	12.6	<12	83	< 300	Pass
+4	712.18	-73.8	710.17	-76.7	2.9	<12	NA	< 300	Pass
+3	712.18	-72.5	710.17	-76.7	4.2	<12	NA	< 300	Pass
+2	712.18	-72.7	710.17	-77.1	4.4	<12	NA	< 300	Pass
+1	712.18	-72.1	710.17	-77.4	5.3	<12	NA	< 300	Pass
+0	712.18	-72.8	710.17	-76.5	3.7	<12	NA	< 300	Pass
-1	712.18	-71.4	710.17	-76.7	5.3	<12	NA	< 300	Pass
-2	712.18	-71.8	710.17	-77.4	5.6	<12	NA	< 300	Pass
-3	712.18	-71	710.17	-77.5	6.5	<12	NA	< 300	Pass
-4	712.18	-75.1	710.17	-77.7	2.6	<12	NA	< 300	Pass
-5	712.18	-75.6	710.17	-77.7	2.1	<12	NA	< 300	Pass

Oscillation Mitigation - Uplink									
Band	776 – 787 MHz								
Test Signal Type	CDMA								
Variable Attenuator Setting	Oscillations		Lowest Output Power Level		Margin	Limit	Time to Mitigate Oscillation	Mitigation Time Limit	Pass / Fail
	Freq.	Level	Freq.	Level					
dB	MHz	dBm	MHz	dBm	dB	dB	sec	sec	
+5	780.55	-52.6	779.16	-66.6	14	<12	116	< 300	Pass
+4	780.55	-70.2	779.16	-73.2	3	<12	NA	< 300	Pass
+3	780.55	-70.1	779.16	-72.5	2.4	<12	NA	< 300	Pass
+2	780.55	-69.6	779.16	-73.5	3.9	<12	NA	< 300	Pass
+1	780.55	-69.5	779.16	-73.2	3.7	<12	NA	< 300	Pass
+0	780.55	-69.2	779.16	-73.2	4	<12	NA	< 300	Pass
-1	780.55	-69.2	779.16	-73.5	4.3	<12	NA	< 300	Pass
-2	780.55	-72.7	779.16	-73.9	1.2	<12	NA	< 300	Pass
-3	780.55	-72.7	779.16	-73.6	0.9	<12	NA	< 300	Pass
-4	780.55	-72.7	779.16	-73.5	0.8	<12	NA	< 300	Pass
-5	780.55	-73.1	779.16	-73.4	0.3	<12	NA	< 300	Pass

Oscillation Mitigation - Uplink									
Band	824 - 849 MHz								
Test Signal Type	CDMA								
Variable Attenuator Setting	Oscillations		Lowest Output Power Level		Margin	Limit	Time to Mitigate Oscillation	Mitigation Time Limit	Pass / Fail
	Freq.	Level	Freq.	Level					
dB	MHz	dBm	MHz	dBm	dB	dB	sec	sec	
+5	833.93	-54.5	831.53	-65.5	11	<12	NA	< 300	Pass
+4	833.93	-52.5	831.53	-65.9	13.4	<12	150	< 300	Pass
+3	833.93	-68.5	831.53	-72.1	3.6	<12	NA	< 300	Pass
+2	833.93	-68.1	831.53	-72.3	4.2	<12	NA	< 300	Pass
+1	833.93	-68.9	831.53	-72.3	3.4	<12	NA	< 300	Pass
+0	833.93	-68	831.53	-71.9	3.9	<12	NA	< 300	Pass
-1	833.93	-67.6	831.53	-72.1	4.5	<12	NA	< 300	Pass
-2	833.93	-67.6	831.53	-72.4	4.8	<12	NA	< 300	Pass
-3	833.93	-66.5	831.53	-71.9	5.4	<12	NA	< 300	Pass
-4	833.93	-66.4	831.53	-72.6	6.2	<12	NA	< 300	Pass
-5	833.93	-66.5	831.53	-72.7	6.2	<12	NA	< 300	Pass

Oscillation Mitigation - Uplink									
Band	1710 - 1755 MHz								
Test Signal Type	CDMA								
Variable Attenuator Setting	Oscillations		Lowest Output Power Level		Margin	Limit	Time to Mitigate Oscillation	Mitigation Time Limit	Pass / Fail
	Freq.	Level	Freq.	Level					
dB	MHz	dBm	MHz	dBm	dB	dB	sec	sec	
+5	1756.7	-48.2	1752.8	-58.4	10.2	<12	NA	< 300	Pass
+4	1756.7	-47.4	1752.8	-58.6	11.2	<12	NA	< 300	Pass
+3	1756.7	-45.6	1752.8	-58.7	13.1	<12	120	< 300	Pass
+2	1756.7	-59.1	1752.8	-61.2	2.1	<12	NA	< 300	Pass
+1	1756.7	-59.1	1752.8	-61.1	2	<12	NA	< 300	Pass
+0	1756.7	-58.7	1752.8	-61.7	3	<12	NA	< 300	Pass
-1	1756.7	-58.1	1752.8	-61.7	3.6	<12	NA	< 300	Pass
-2	1756.7	-57.6	1752.8	-61.8	4.2	<12	NA	< 300	Pass
-3	1756.7	-57.9	1752.8	-62.1	4.2	<12	NA	< 300	Pass
-4	1756.7	-57.5	1752.8	-62.8	5.3	<12	NA	< 300	Pass
-5	1756.7	-57.1	1752.8	-62.4	5.3	<12	NA	< 300	Pass

Oscillation Mitigation - Uplink									
Band	1850 - 1910 MHz								
Test Signal Type	CDMA								
Variable Attenuator Setting	Oscillations		Lowest Output Power Level		Margin	Limit	Time to Mitigate Oscillation	Mitigation Time Limit	Pass / Fail
	Freq.	Level	Freq.	Level					
dB	MHz	dBm	MHz	dBm	dB	dB	sec	sec	
+5	1862.1	-37.4	1858.1	-58.2	20.8	<12	150	< 300	Pass
+4	1862.1	-57.8	1858.1	-60.2	2.4	<12	NA	< 300	Pass
+3	1862.1	-56.6	1858.1	-60.4	3.8	<12	NA	< 300	Pass
+2	1862.1	-56.1	1858.1	-60.4	4.3	<12	NA	< 300	Pass
+1	1862.1	-56.1	1858.1	-60.1	4	<12	NA	< 300	Pass
+0	1862.1	-56.2	1858.1	-60.8	4.6	<12	NA	< 300	Pass
-1	1862.1	-55.7	1858.1	-61.4	5.7	<12	NA	< 300	Pass
-2	1862.1	-55.7	1858.1	-60.9	5.2	<12	NA	< 300	Pass
-3	1862.1	-59.1	1858.1	-59.6	0.5	<12	NA	< 300	Pass
-4	1862.1	-58.7	1858.1	-59.4	0.7	<12	NA	< 300	Pass
-5	1862.1	-58.2	1858.1	-59.2	1	<12	NA	< 300	Pass

### Downlink Oscillation Mitigation Test Data

Oscillation Mitigation - Downlink									
Band	728 - 746 MHz								
Test Signal Type	CDMA								
Variable Attenuator Setting	Oscillations		Lowest Output Power Level		Margin	Limit	Time to Mitigate Oscillation	Mitigation Time Limit	Pass / Fail
	Freq.	Level	Freq.	Level					
dB	MHz	dBm	MHz	dBm	dB	dB	sec	sec	
+5	745.31	-57.4	742.91	-65.3	7.9	<12	NA	< 300	Pass
+4	745.31	-56.5	742.91	-64.8	8.3	<12	NA	< 300	Pass
+3	745.31	-57	742.91	-66.9	9.9	<12	NA	< 300	Pass
+2	745.31	-55.4	742.91	-67.3	11.9	<12	NA	< 300	Pass
+1	745.31	-53.5	742.91	-67.8	14.3	<12	84	< 300	Pass
+0	745.31	-77.1	742.91	-77.3	0.2	<12	NA	< 300	Pass
-1	745.31	-76.1	742.91	-77.5	1.4	<12	NA	< 300	Pass
-2	745.31	-75.4	742.91	-77.5	2.1	<12	NA	< 300	Pass
-3	745.31	-75.1	742.91	-77.5	2.4	<12	NA	< 300	Pass
-4	745.31	-75	742.91	-78.2	3.2	<12	NA	< 300	Pass
-5	745.31	-73.6	742.91	-77.6	4	<12	NA	< 300	Pass

Oscillation Mitigation - Downlink									
Band	746 - 757 MHz								
Test Signal Type	CDMA								
Variable Attenuator Setting	Oscillations		Lowest Output Power Level		Margin	Limit	Time to Mitigate Oscillation	Mitigation Time Limit	Pass / Fail
	Freq.	Level	Freq.	Level					
dB	MHz	dBm	MHz	dBm	dB	dB	sec	sec	
+5	742.98	-54.3	745.41	-66.5	12.2	<12	143	< 300	Pass
+4	742.98	-76.5	745.41	-79.8	3.3	<12	NA	< 300	Pass
+3	742.98	-76.5	745.41	-80.1	3.6	<12	NA	< 300	Pass
+2	742.98	-77	745.41	-79.5	2.5	<12	NA	< 300	Pass
+1	742.98	-76.5	745.41	-80.2	3.7	<12	NA	< 300	Pass
+0	742.98	-76.2	745.41	-80	3.8	<12	NA	< 300	Pass
-1	742.98	-76	745.41	-80.2	4.2	<12	NA	< 300	Pass
-2	742.98	-80.8	745.41	-75.9	-4.9	<12	NA	< 300	Pass
-3	742.98	-75.3	745.41	-80.9	5.6	<12	NA	< 300	Pass
-4	742.98	-76.2	745.41	-80.5	4.3	<12	NA	< 300	Pass
-5	742.98	-75.9	745.41	-80.4	4.5	<12	NA	< 300	Pass

Oscillation Mitigation - Downlink									
Band	869 - 894 MHz								
Test Signal Type	CDMA								
Variable Attenuator Setting	Oscillations		Lowest Output Power Level		Margin	Limit	Time to Mitigate Oscillation	Mitigation Time Limit	Pass / Fail
	Freq.	Level	Freq.	Level					
dB	MHz	dBm	MHz	dBm	dB	dB	sec	sec	
+5	878.4	-55.4	880.4	-64.5	9.1	<12	NA	< 300	Pass
+4	878.4	-53.1	880.4	-66.4	13.3	<12	20	< 300	Pass
+3	878.4	-74.4	880.4	-76.4	2	<12	NA	< 300	Pass
+2	878.4	-74.5	880.4	-76.2	1.7	<12	NA	< 300	Pass
+1	878.4	-74.1	880.4	-76.3	2.2	<12	NA	< 300	Pass
+0	878.4	-73.7	880.4	-76.7	3	<12	NA	< 300	Pass
-1	878.4	-73.2	880.4	-76.5	3.3	<12	NA	< 300	Pass
-2	878.4	-73.2	880.4	-76.9	3.7	<12	NA	< 300	Pass
-3	878.4	-73.2	880.4	-77	3.8	<12	NA	< 300	Pass
-4	878.4	-72.6	880.4	-76.9	4.3	<12	NA	< 300	Pass
-5	878.4	-72.4	880.4	-77.5	5.1	<12	NA	< 300	Pass





Oscillation Mitigation - Downlink									
Band	1930 - 1990 MHz								
Test Signal Type	CDMA								
Variable Attenuator Setting	Oscillations		Lowest Output Power Level		Margin	Limit	Time to Mitigate Oscillation	Mitigation Time Limit	Pass / Fail
	Freq.	Level	Freq.	Level					
dB	MHz	dBm	MHz	dBm	dB	dB	sec	sec	
+5	1969	-46.1	1974.5	-57.9	11.8	<12	NA	< 300	Pass
+4	1969	-45.1	1974.5	-58.7	13.6	<12	150	< 300	Pass
+3	1969	-67.4	1974.5	-67.2	-0.2	<12	NA	< 300	Pass
+2	1969	-65.4	1974.5	-67.7	2.3	<12	NA	< 300	Pass
+1	1969	-65.8	1974.5	-67.8	2	<12	NA	< 300	Pass
+0	1969	-65.5	1974.5	-68.2	2.7	<12	NA	< 300	Pass
-1	1969	-65.1	1974.5	-68.3	3.2	<12	NA	< 300	Pass
-2	1969	-65.6	1974.5	-68.3	2.7	<12	NA	< 300	Pass
-3	1969	-64.7	1974.5	-67.7	3	<12	NA	< 300	Pass
-4	1969	-65.2	1974.5	-68.3	3.1	<12	NA	< 300	Pass
-5	1969	-64.9	1974.5	-68.7	3.8	<12	NA	< 300	Pass

Oscillation Mitigation - Uplink									
Band	2110 - 2155 MHz								
Test Signal Type	CDMA								
Variable Attenuator Setting	Oscillations		Lowest Output Power Level		Margin	Limit	Time to Mitigate Oscillation	Mitigation Time Limit	Pass / Fail
	Freq.	Level	Freq.	Level					
dB	MHz	dBm	MHz	dBm	dB	dB	sec	sec	
+5	2138.6	-47.5	2133.1	-59.1	11.6	<12	NA	< 300	Pass
+4	2138.6	-45.6	2133.1	-58.9	13.3	<12	15	< 300	Pass
+3	2138.6	-64.2	2133.1	-65.7	1.5	<12	NA	< 300	Pass
+2	2138.6	-64.1	2133.1	-65.2	1.1	<12	NA	< 300	Pass
+1	2138.6	-63.5	2133.1	-66.2	2.7	<12	NA	< 300	Pass
+0	2138.6	-63.8	2133.1	-65.9	2.1	<12	NA	< 300	Pass
-1	2138.6	-63.4	2133.1	-66.2	2.8	<12	NA	< 300	Pass
-2	2138.6	-62.7	2133.1	-66.3	3.6	<12	NA	< 300	Pass
-3	2138.6	-63.4	2133.1	-67.1	3.7	<12	NA	< 300	Pass
-4	2138.6	-62.8	2133.1	-66.5	3.7	<12	NA	< 300	Pass
-5	2138.6	-66.9	2133.1	-66.9	0	<12	NA	< 300	Pass

## Radiated Spurious

**Engineer:** Greg Corbin

**Test Date:** 12/15/2016

### Test Procedure

The EUT was tested in a semi-anechoic chamber with the turntable set 3m from the receiving antenna. A spectrum analyzer was used to verify that the EUT met the requirements for Radiated Emissions. The EUT was tested by rotating it 360 degrees with the antenna in both the vertical and horizontal orientation while raised from 1 to 4 meters to ensure that the signal levels were maximized. All cable and antenna correction factors were input into the spectrum analyzer ensuring an accurate measurement in ERP/EIRP with the resultant power in dBm. A signal generator was used to provide a CW signal centered in each operational uplink and downlink band. The EUT output was terminated into a 50 Ohm non-radiating load.

The following formula was used for calculating the limits:

Radiated Spurious Emissions Limit =  $P1 - (43 + 10\text{Log}(P2)) = -13\text{dBm}$

P1 = power in dBm

P2 = power in Watts

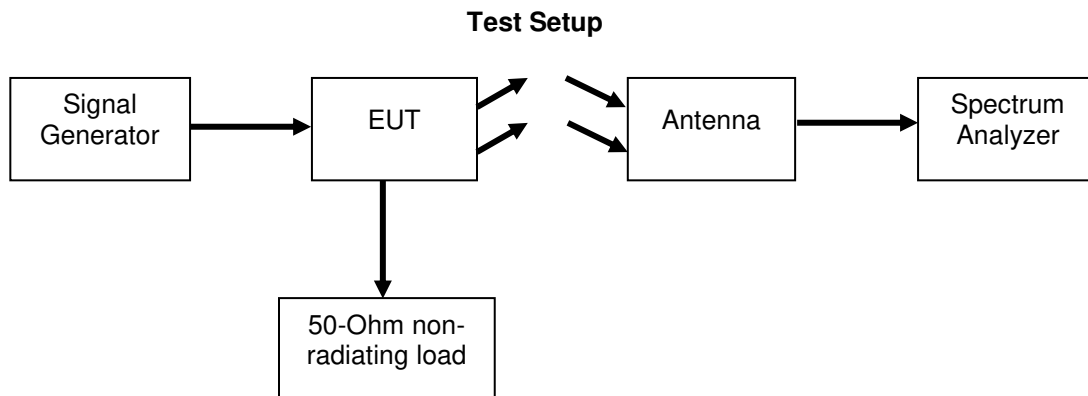

### Refer to Annex J for Radiated Spurious Emission plots

All emissions were lower than -13 dBm.

## Test Equipment Utilized

Description	Manufacturer	Model #	CT Asset #	Last Cal Date	Cal Due Date
Horn Antenna	ARA	DRG-118/A	i00271	6/16/16	6/16/18
Humidity / Temp Meter	Newport	IBTHX-W-5	i00282	5/26/16	5/26/17
Bi-Log Antenna	Schaffner	CBL 6111D	i00349	8/3/16	8/3/18
EMI Analyzer	Agilent	E7405A	i00379	2/11/16	2/11/17
Signal Generator	Rohde & Schwarz	SMU200A	i00405	1/22/16	1/22/17
Spectrum Analyzer	Texttronix	RSA5126A	i00424	3/28/16	3/28/17
3 Meter Semi-Anechoic Chamber	Panashield	3 Meter Semi-Anechoic Chamber	i00428	8/15/16	8/15/19
Preamplifier	Miteq	AFS44 00101 400 23-10P-44	i00509	N/A	N/A

In addition to the above listed equipment standard RF connectors and cables were utilized in the testing of the described equipment. Prior to testing these components were tested to verify proper operation.

END OF TEST REPORT