

2110 - 2155 MHz Band

Input

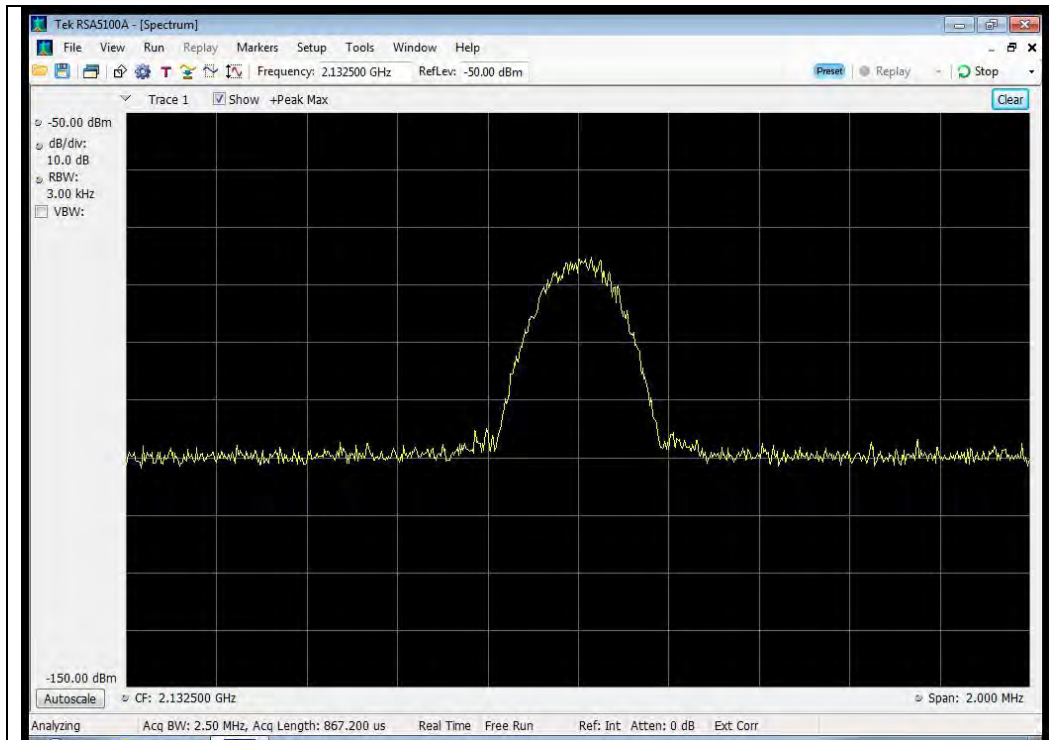

Output

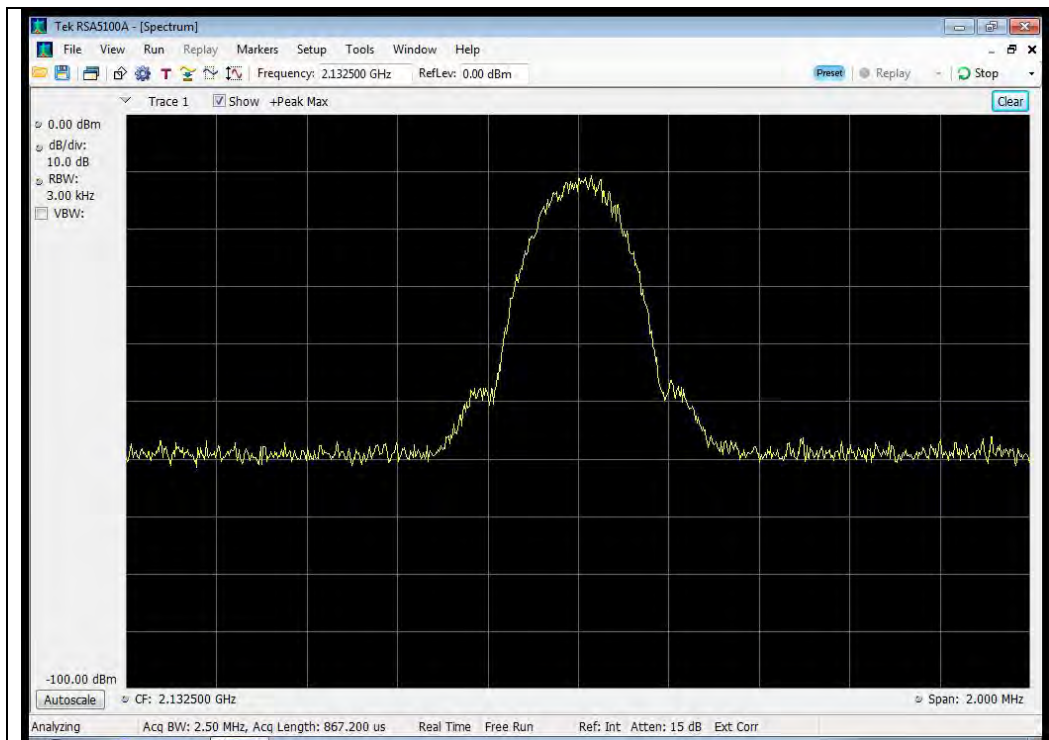

CDMA Uplink Test Plots

698 - 716 MHz Band

Input

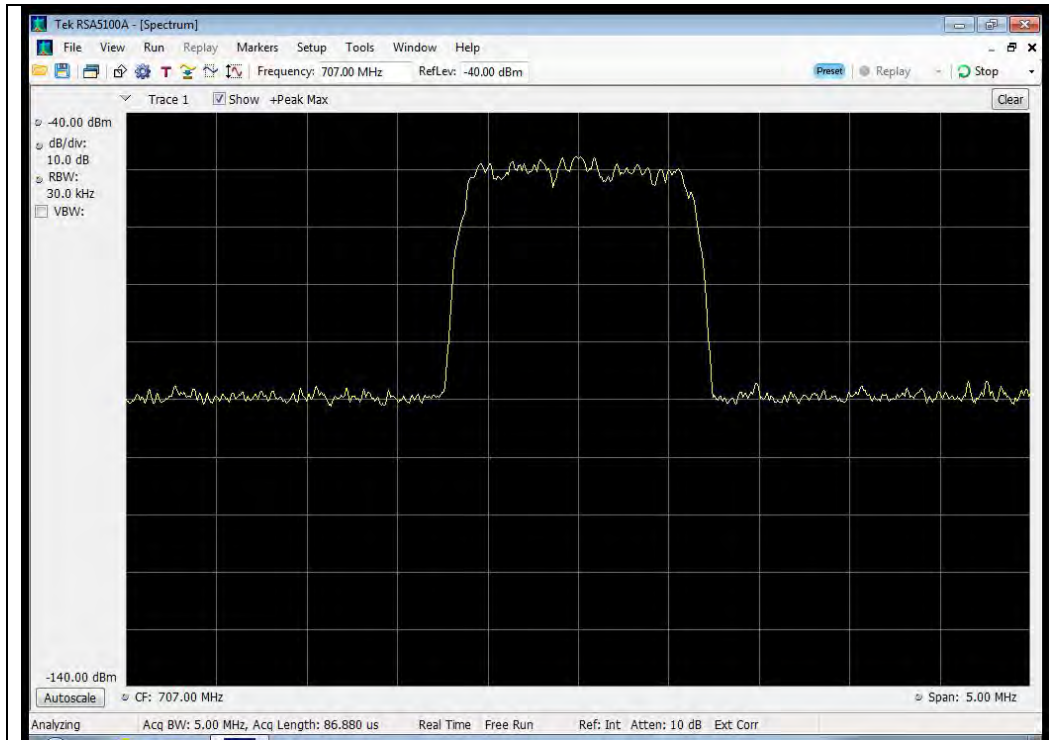

Output

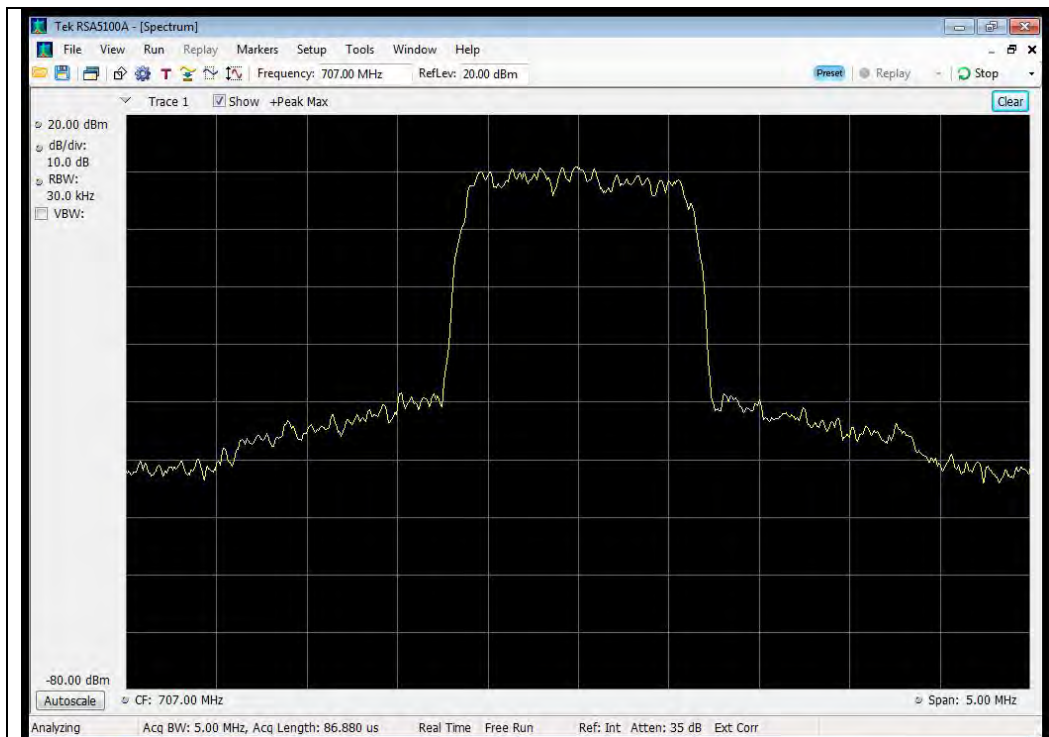

776 - 787 MHz Band

Input

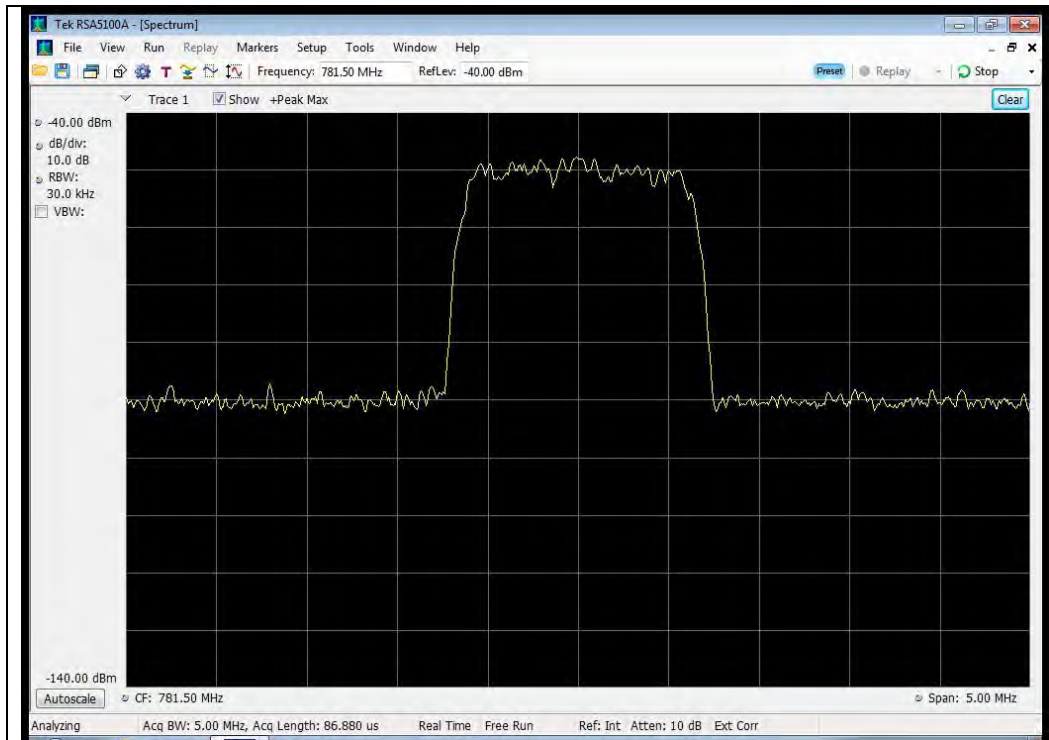

Output

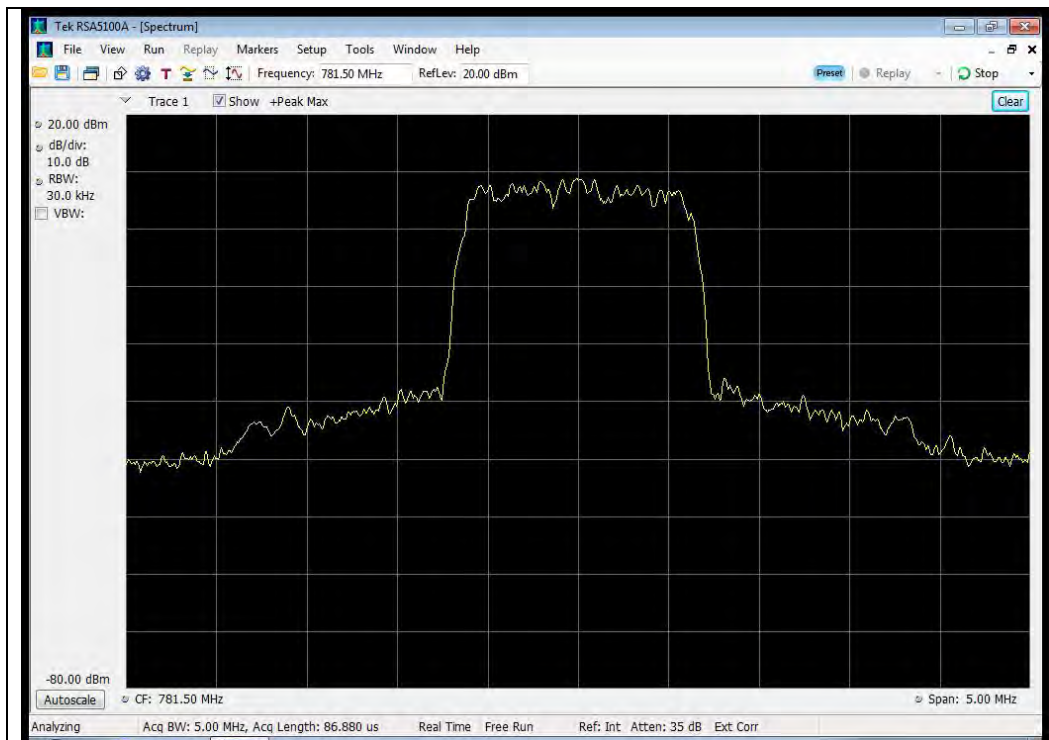

824 - 849 MHz Band

Input

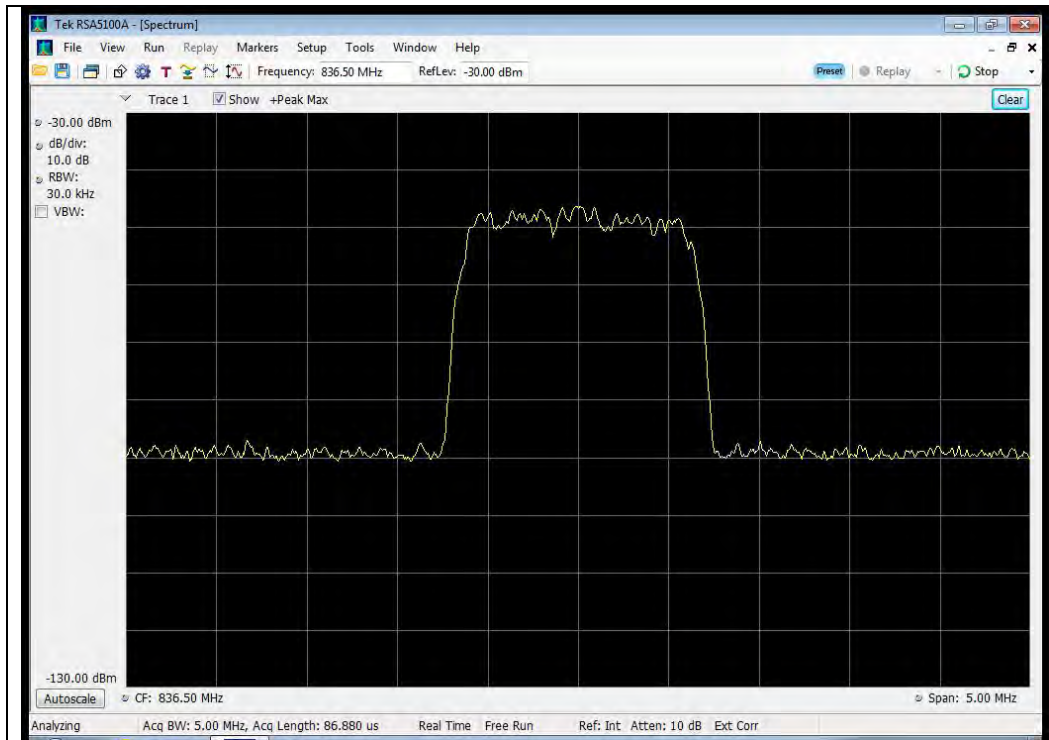

Output

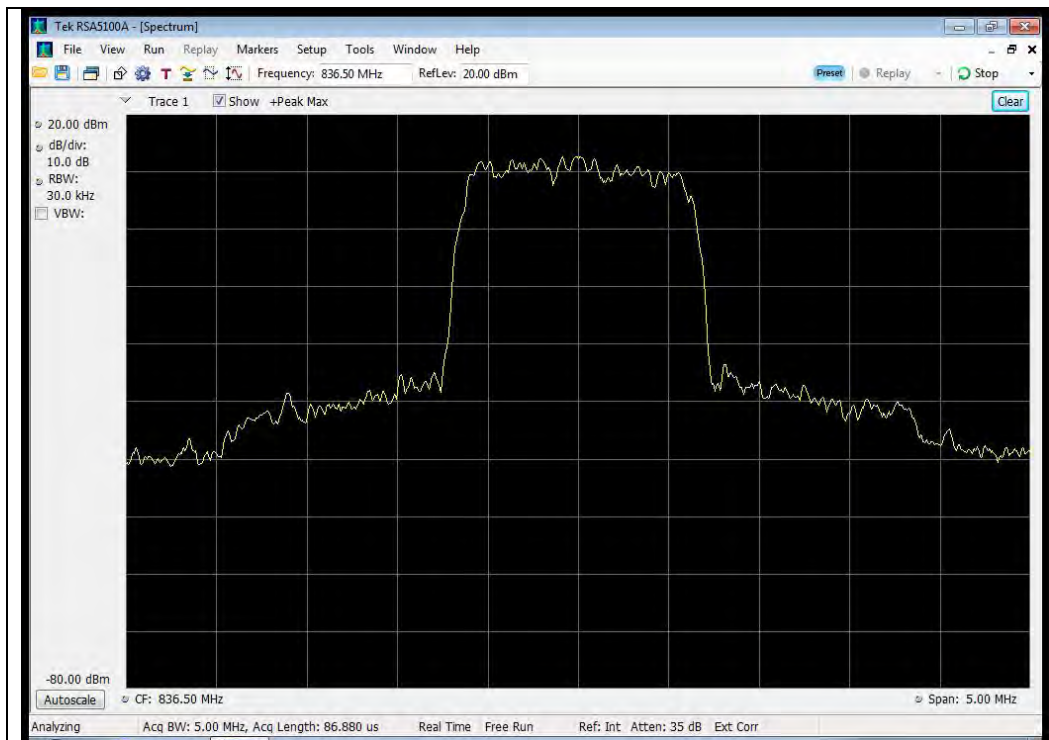

1710 - 1755 MHz Band

Input

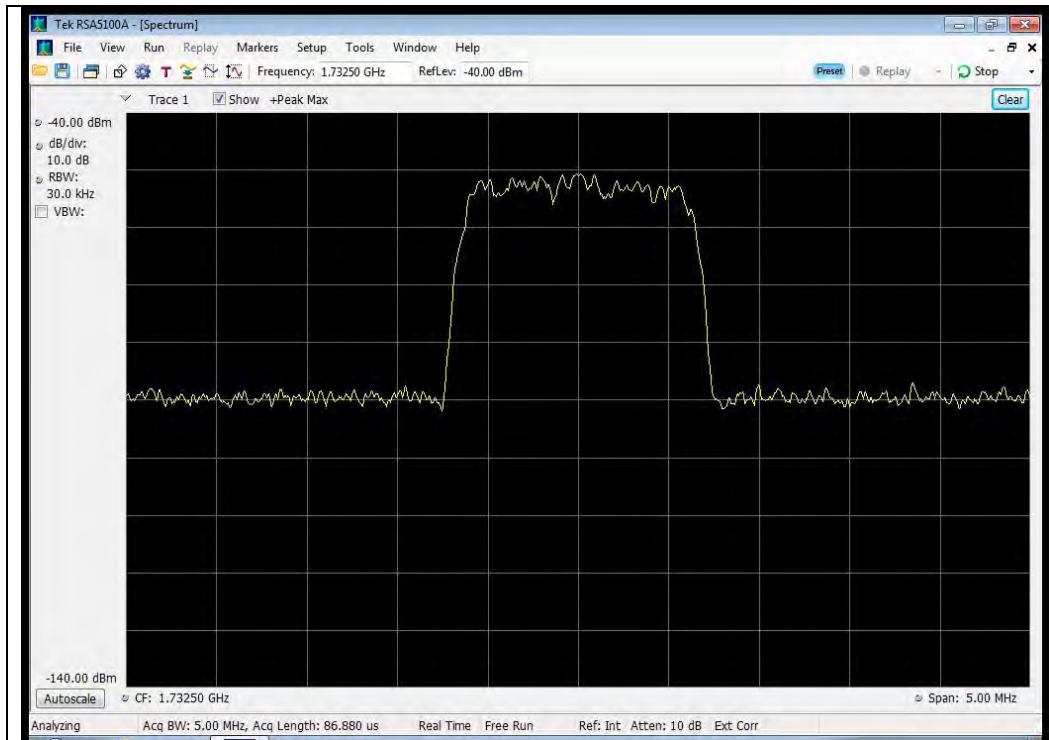

Output

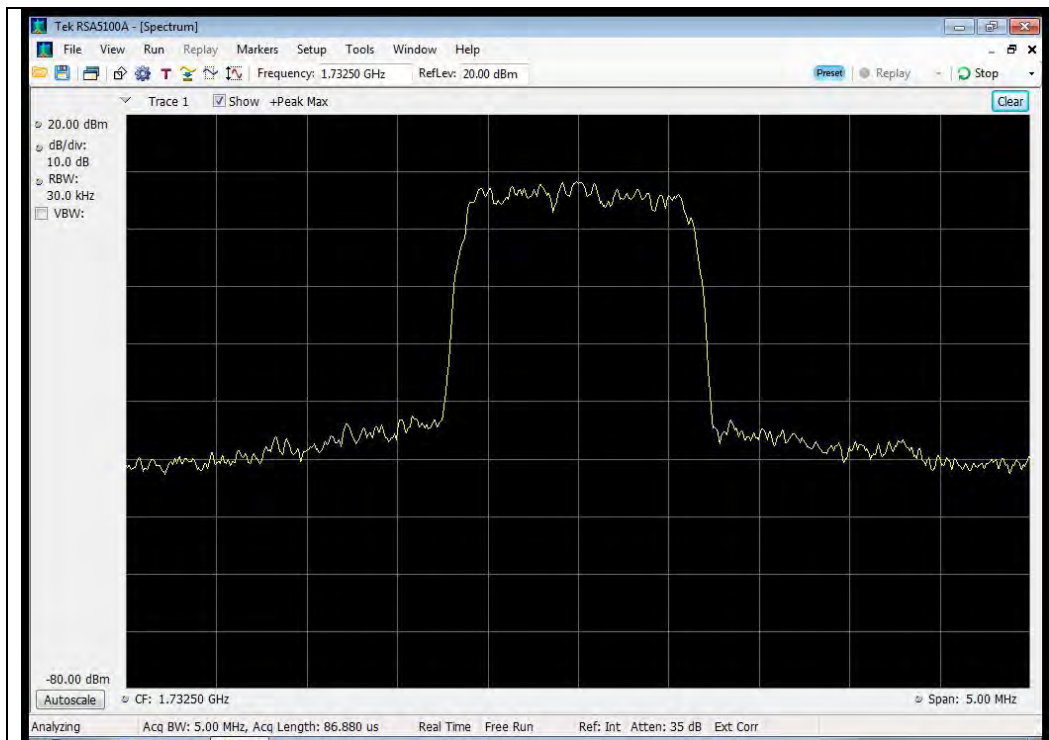

1850 - 1915 MHz Band

Input

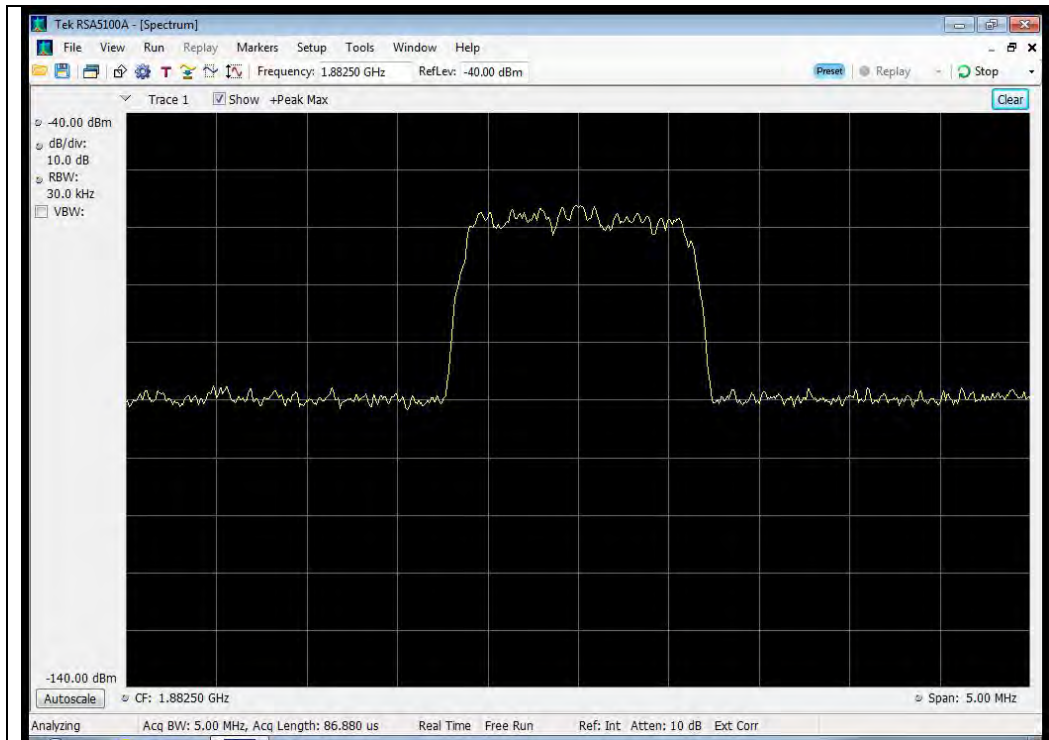

Output

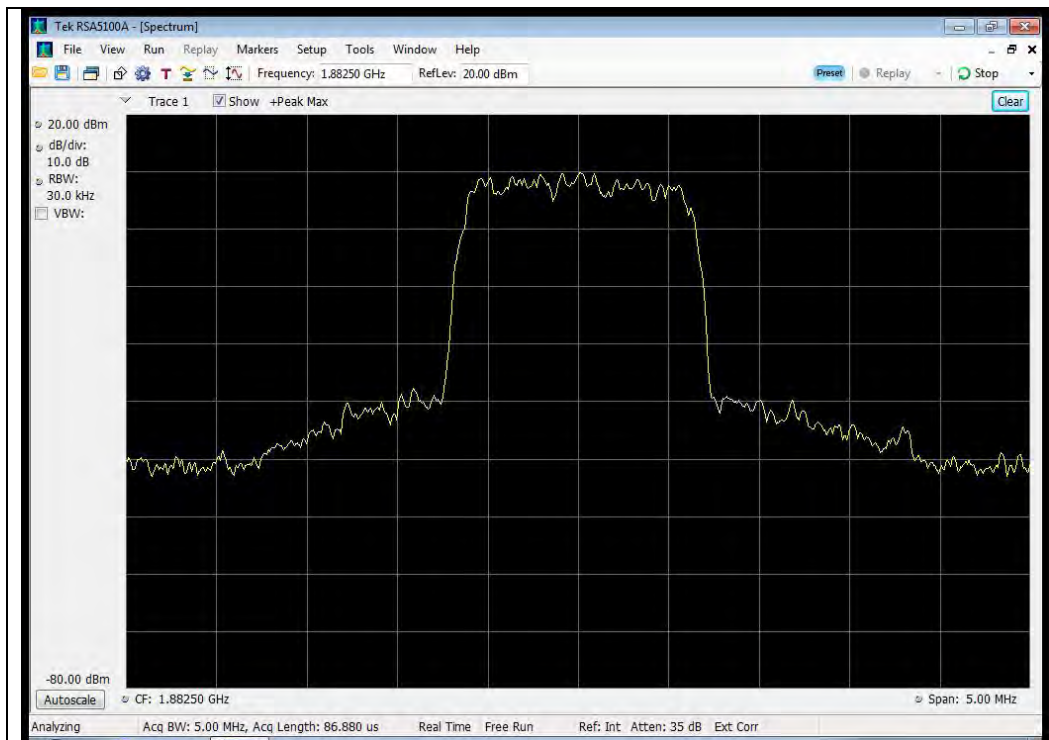

CDMA Downlink Test Plots

728 - 746 MHz Band

Input

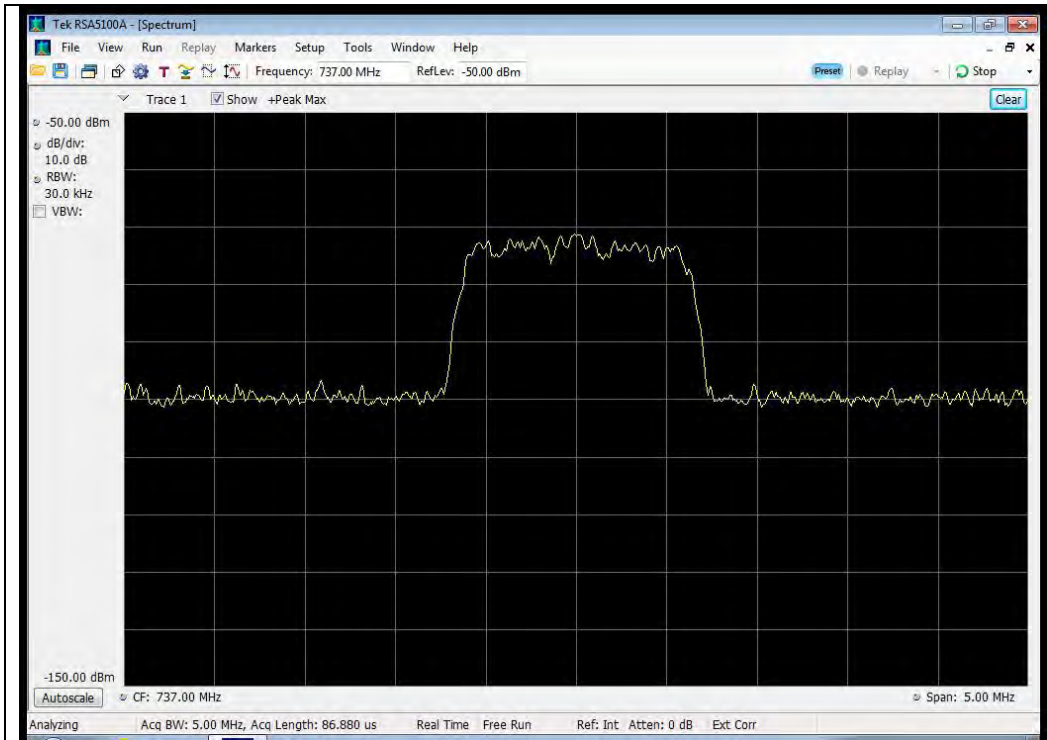

Output

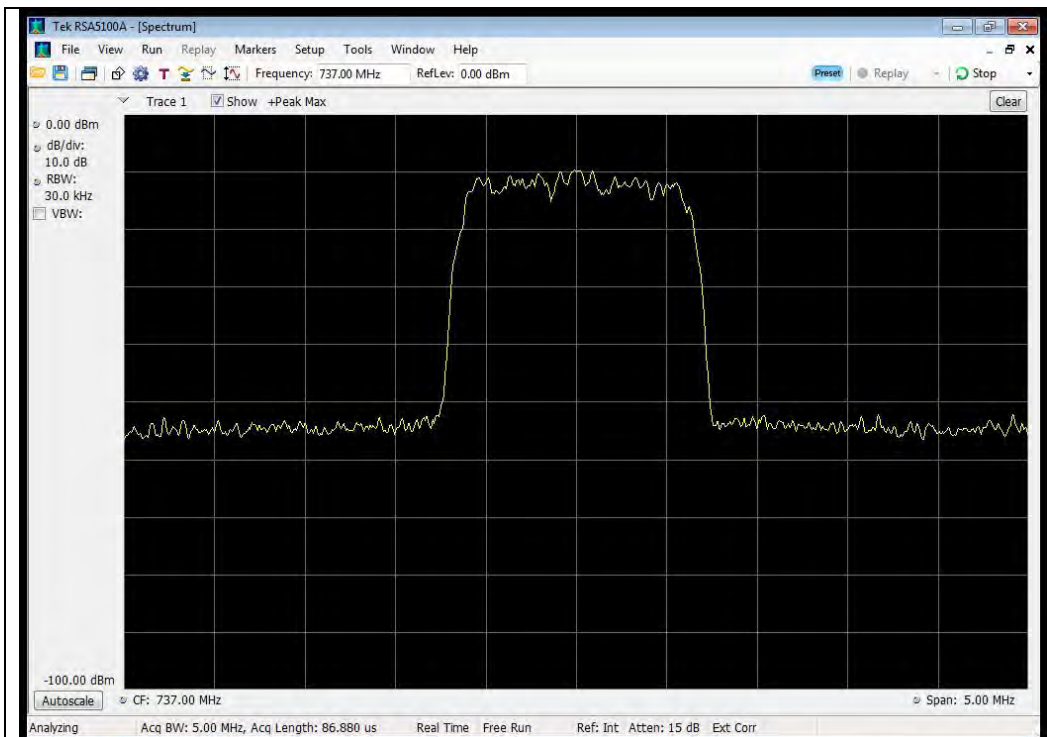

746 - 757 MHz Band

Input

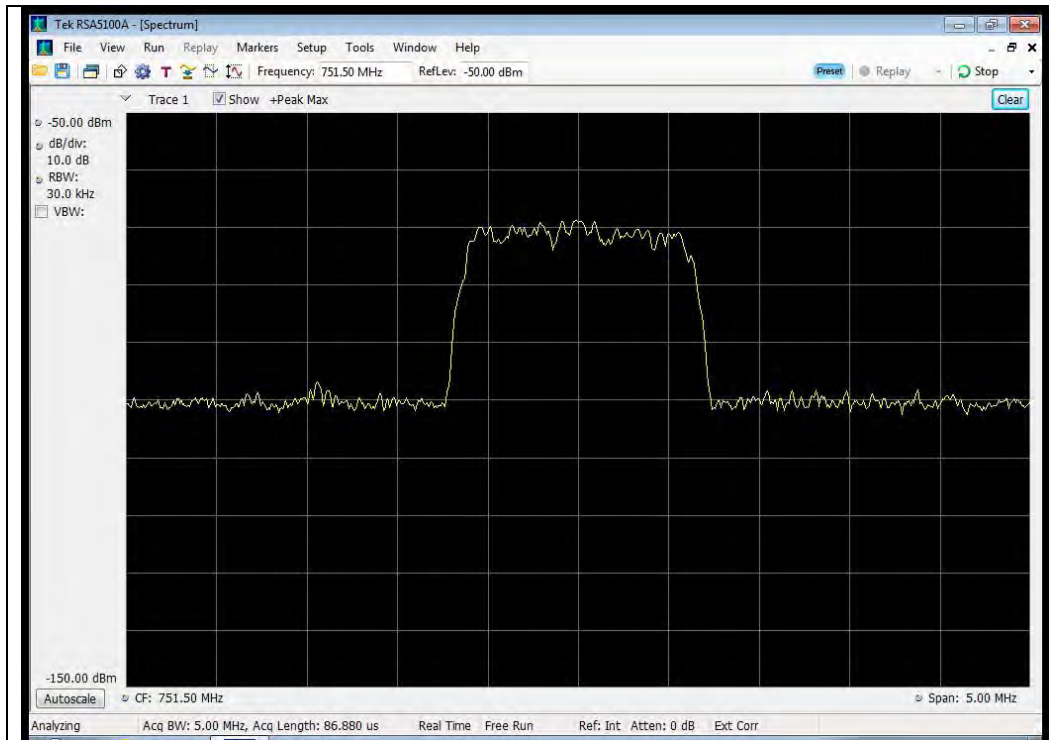

Output

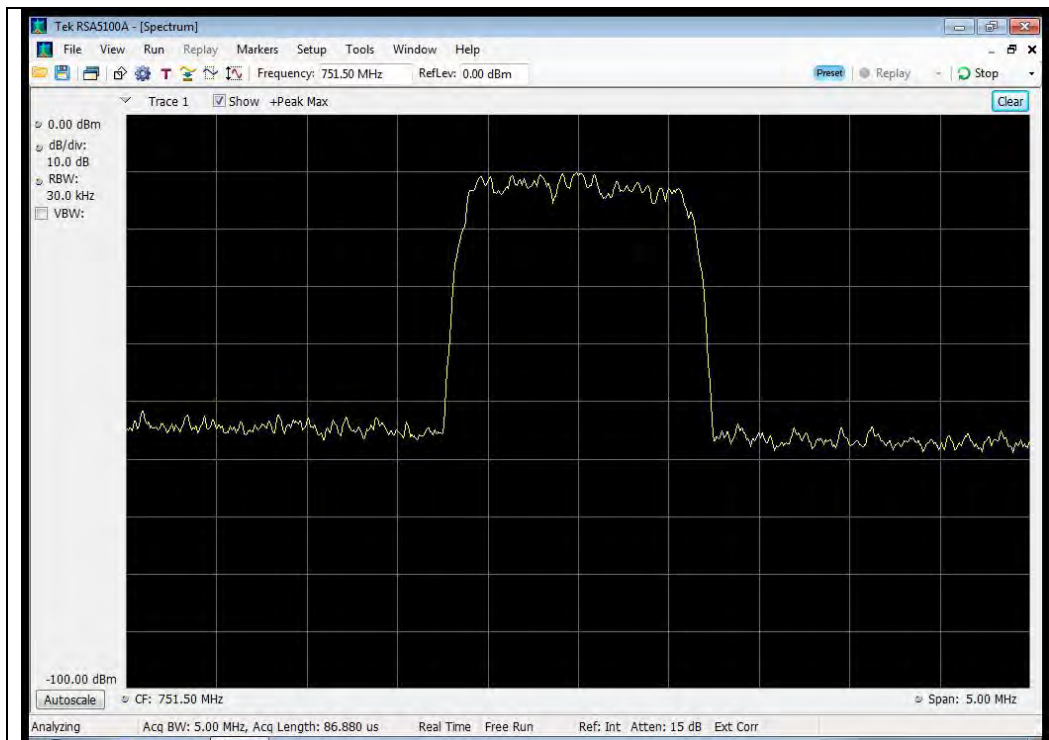

869 - 894 MHz Band

Input

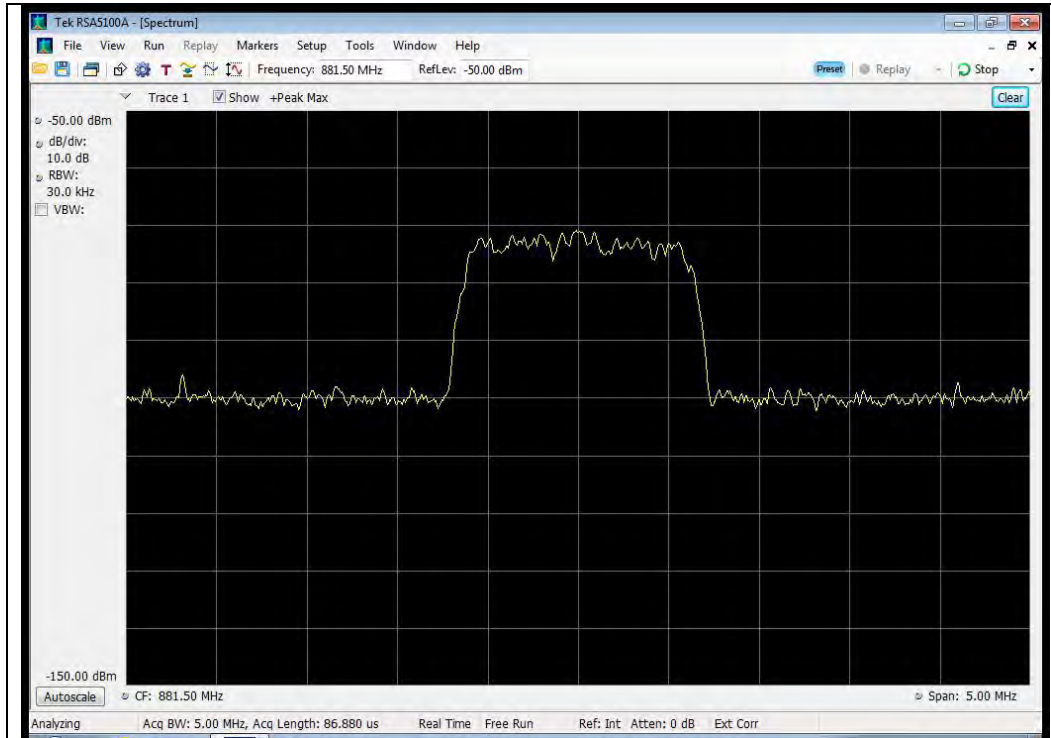

Output

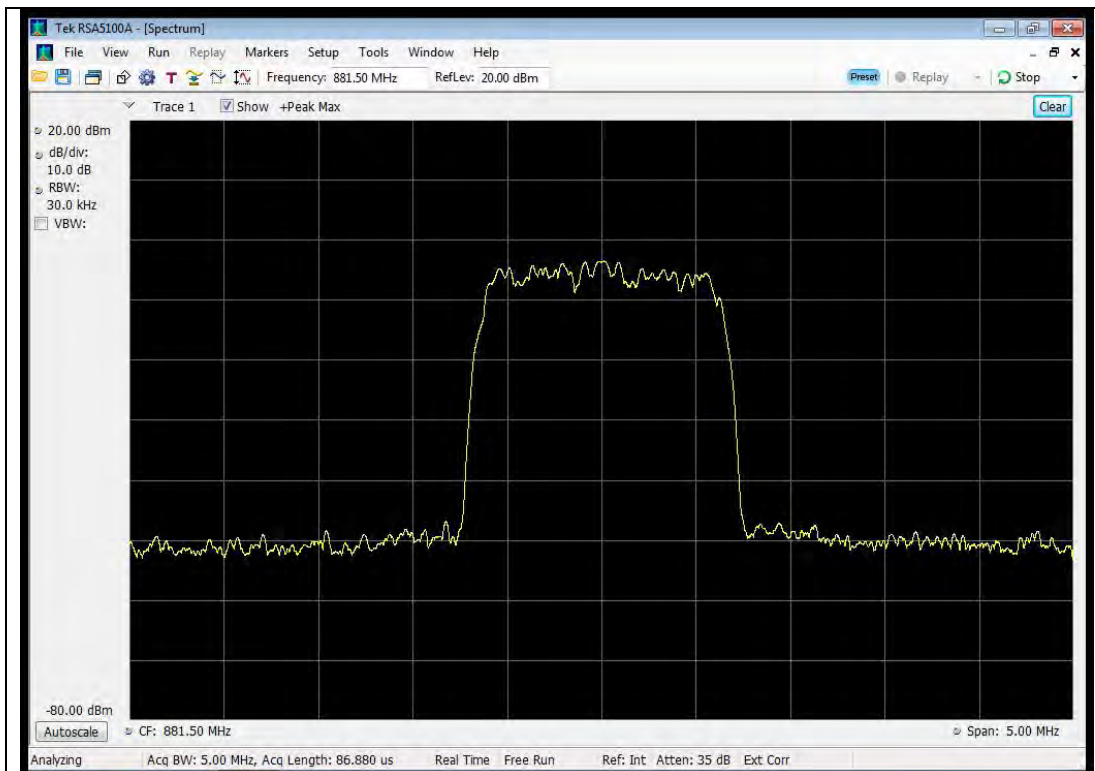

1930 - 1995 MHz Band

Input

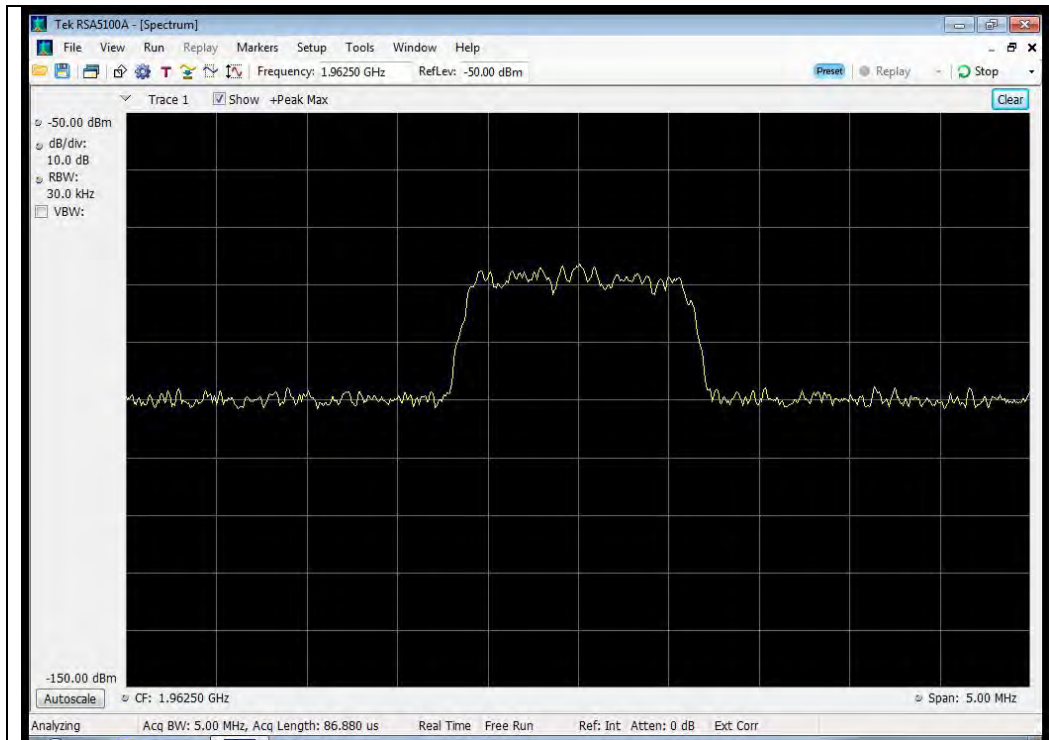

Output

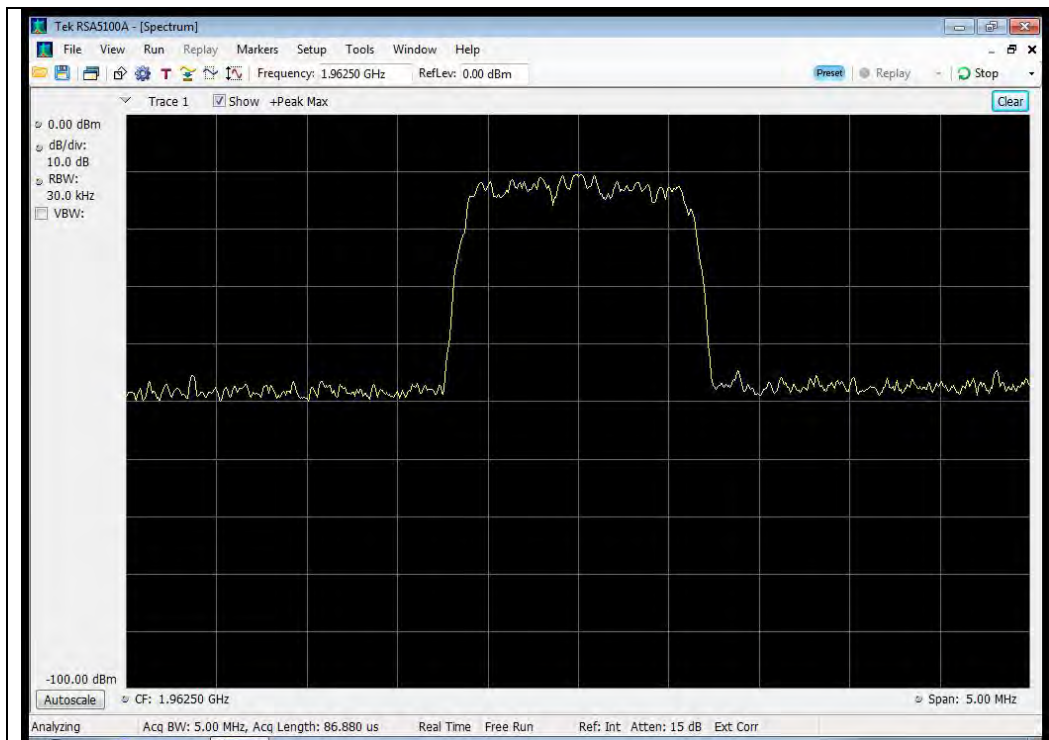

2110 - 2155 MHz Band

Input

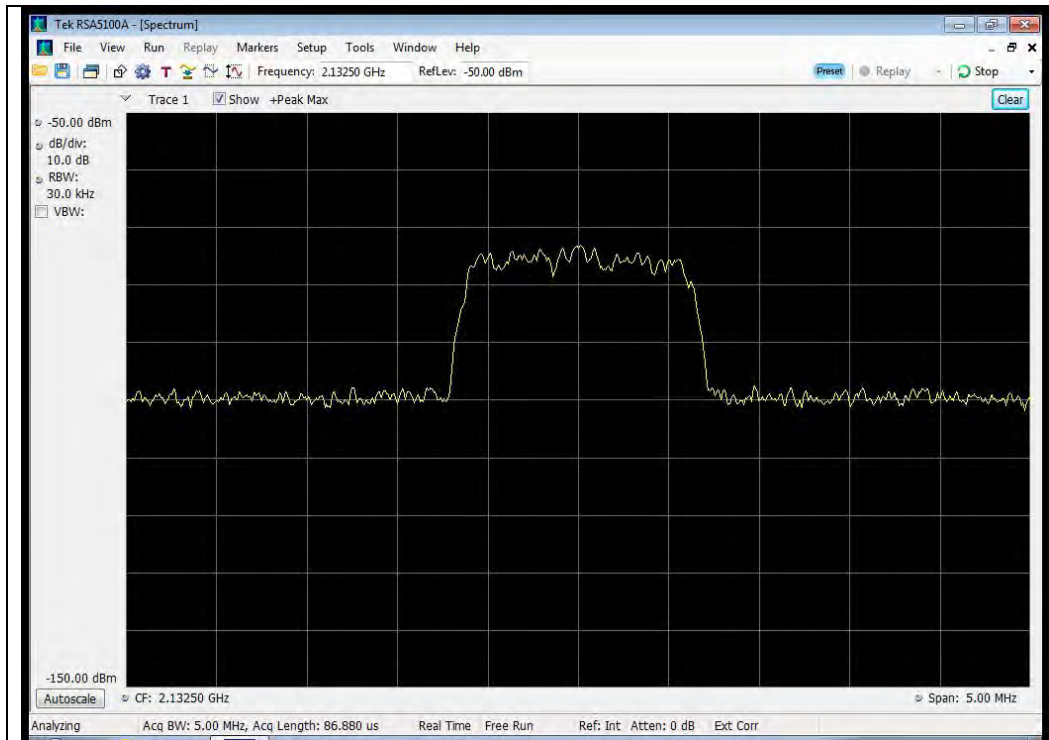

Output

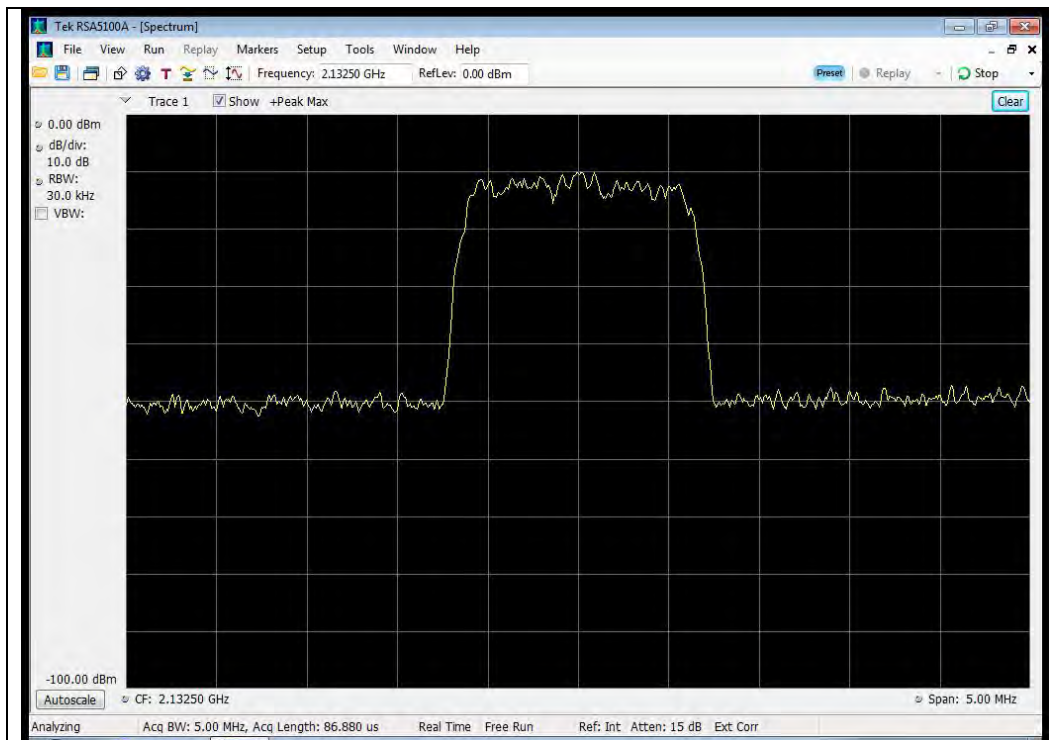

WCDMA Uplink Test Plots

698 - 716 MHz Band

Input

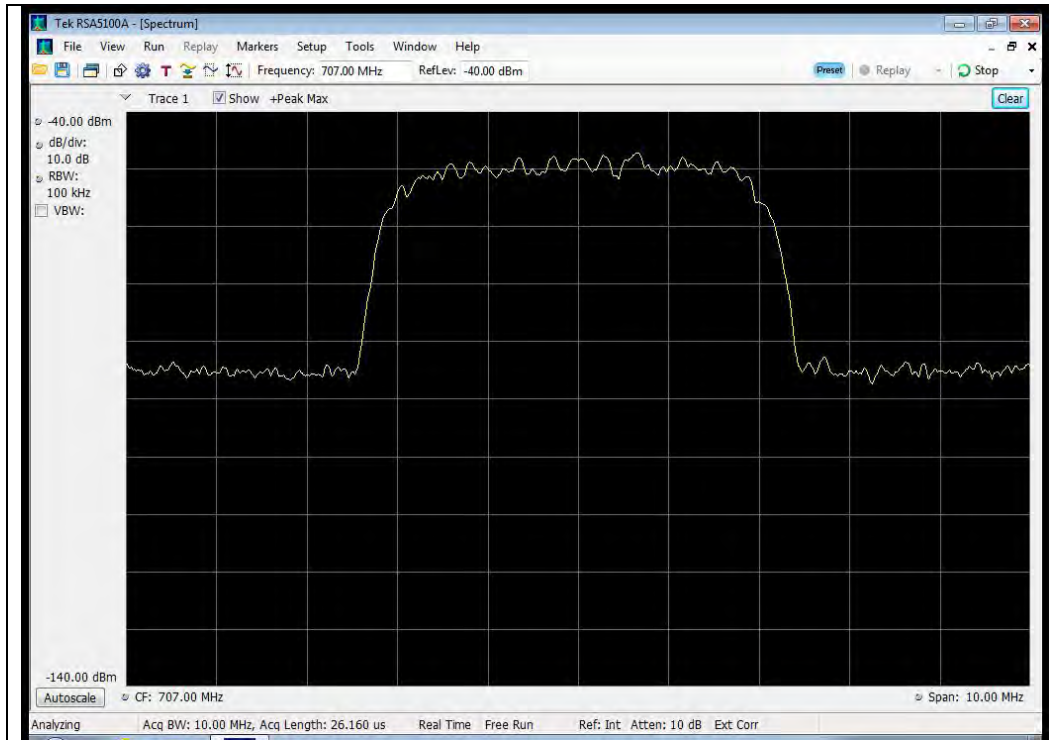

Output

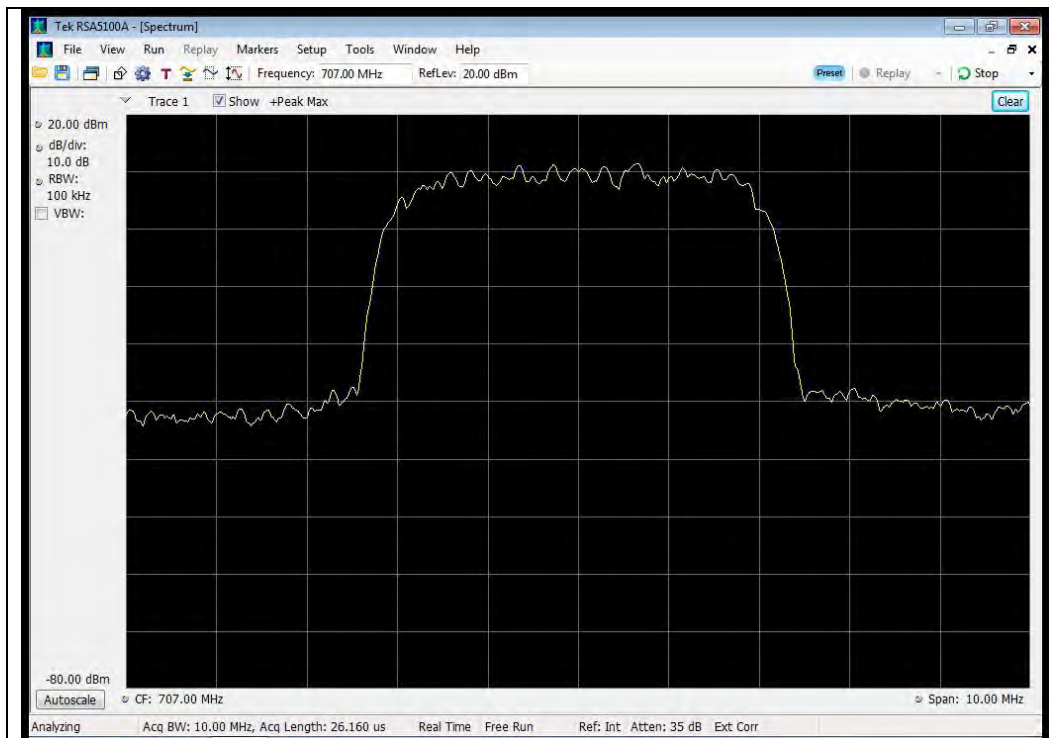

776 - 787 MHz Band

Input

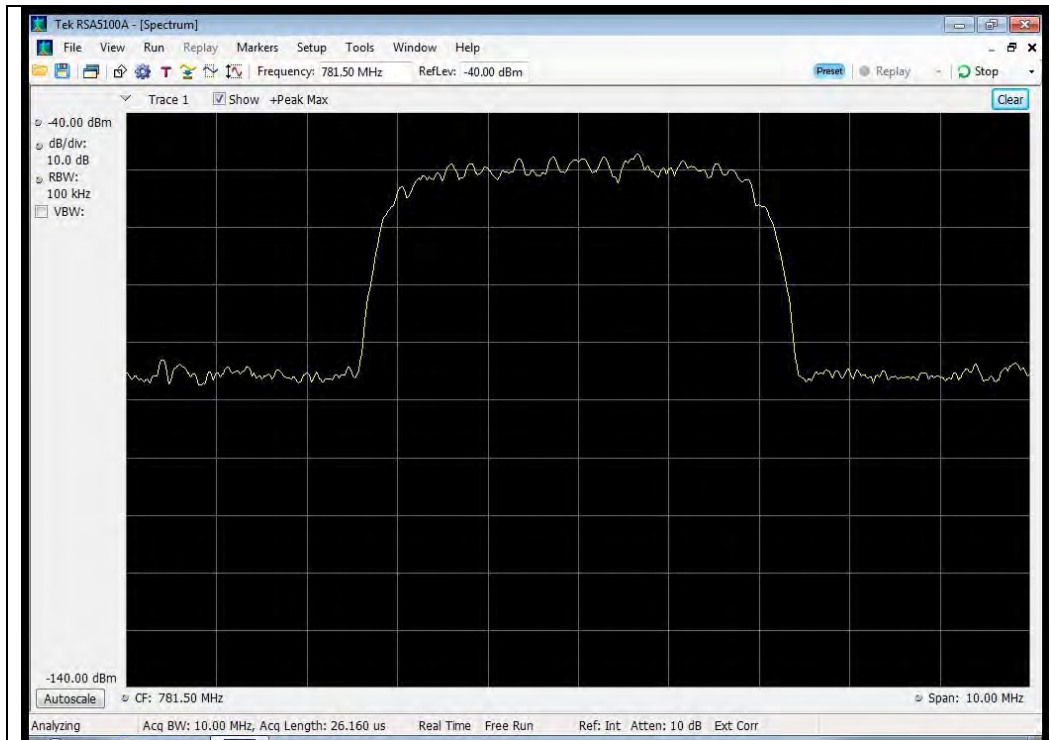

Output

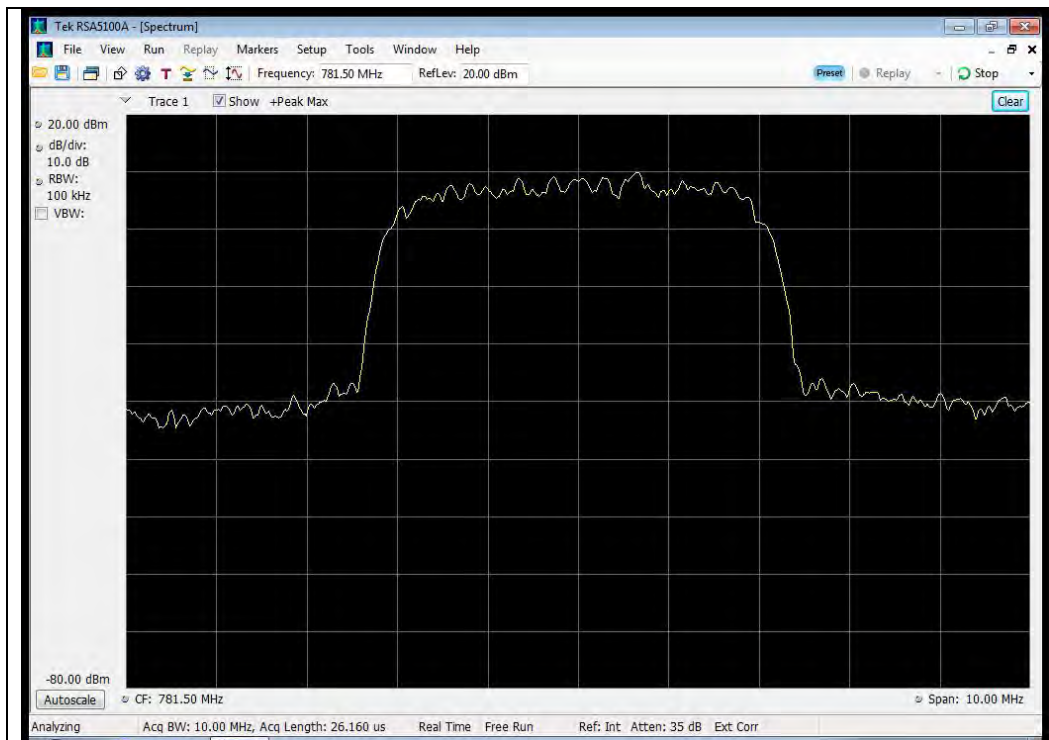

824 - 849 MHz Band

Input

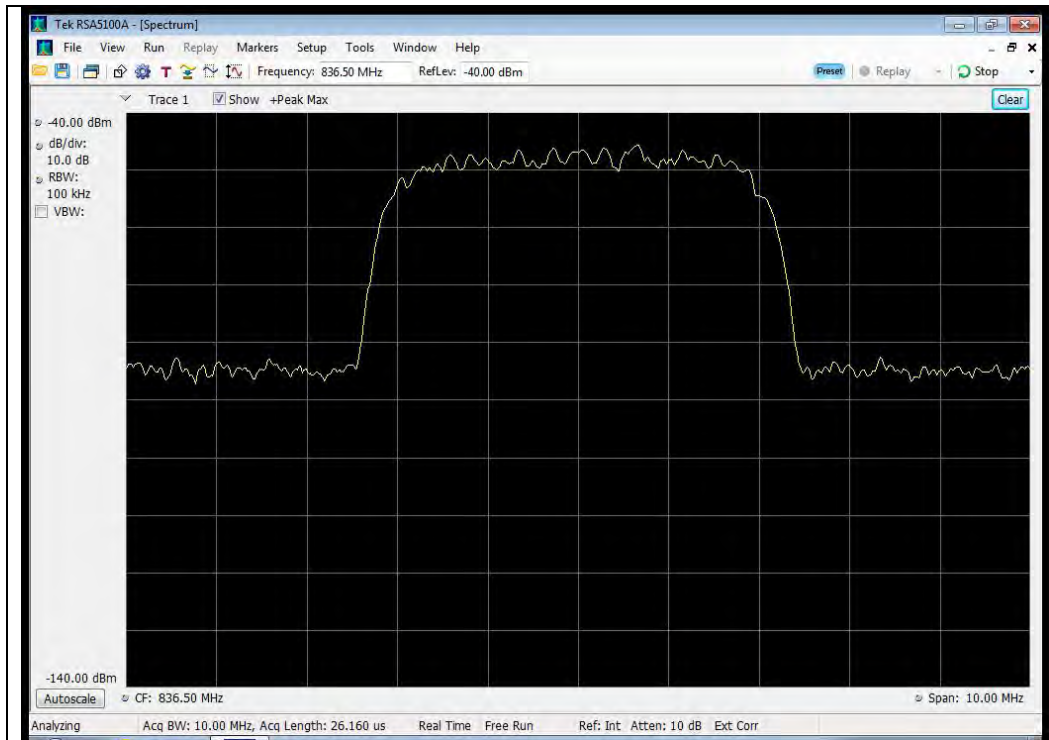

Output

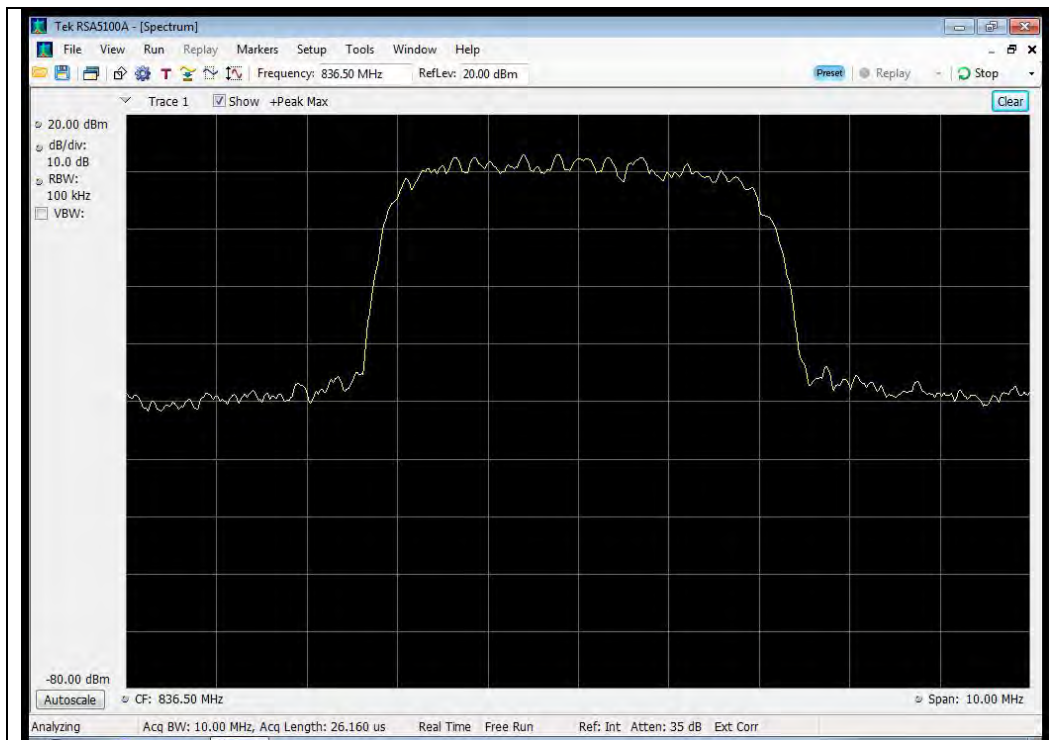

1710 - 1755 MHz Band

Input

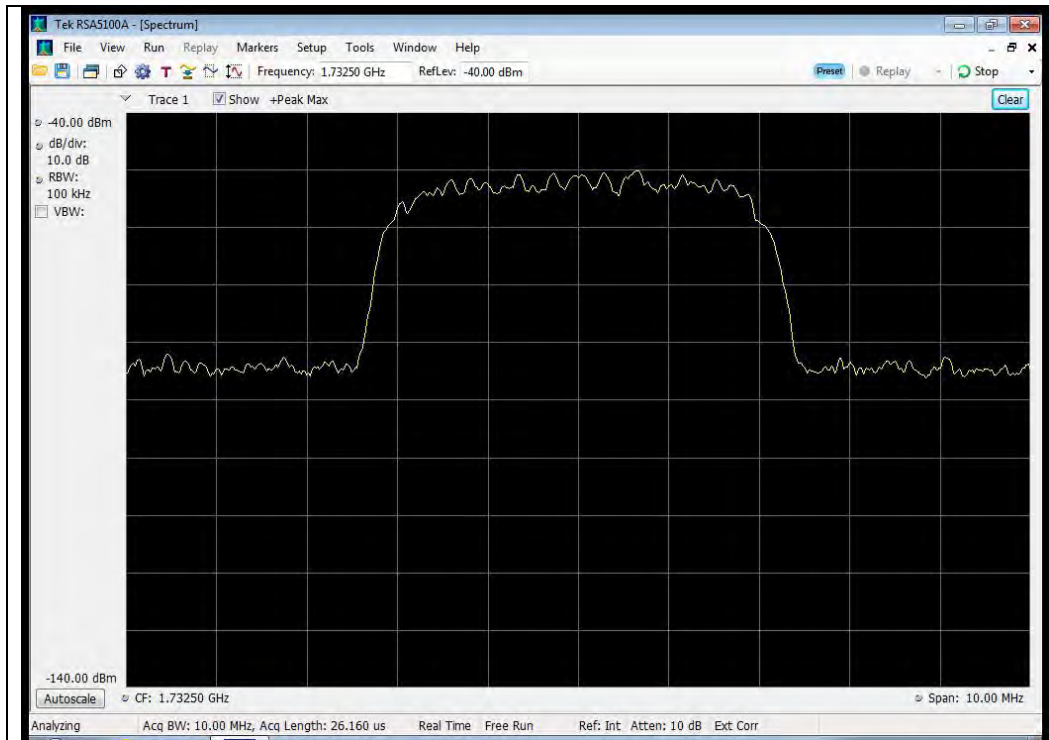

Output

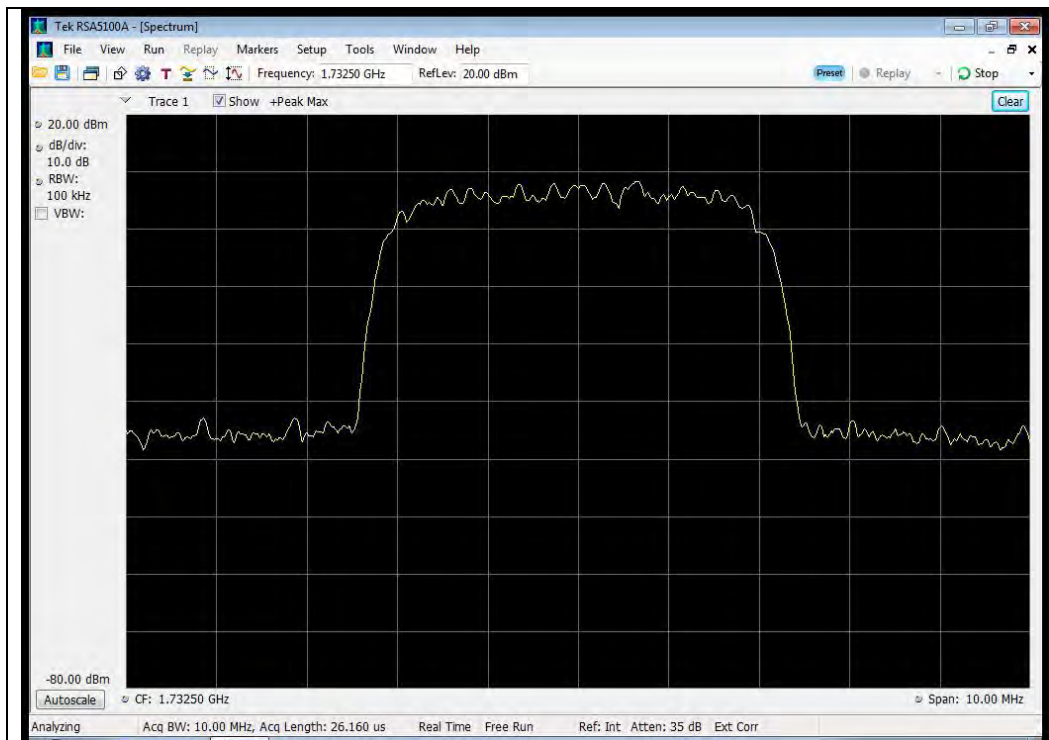

1850 - 1915 MHz Band

Input

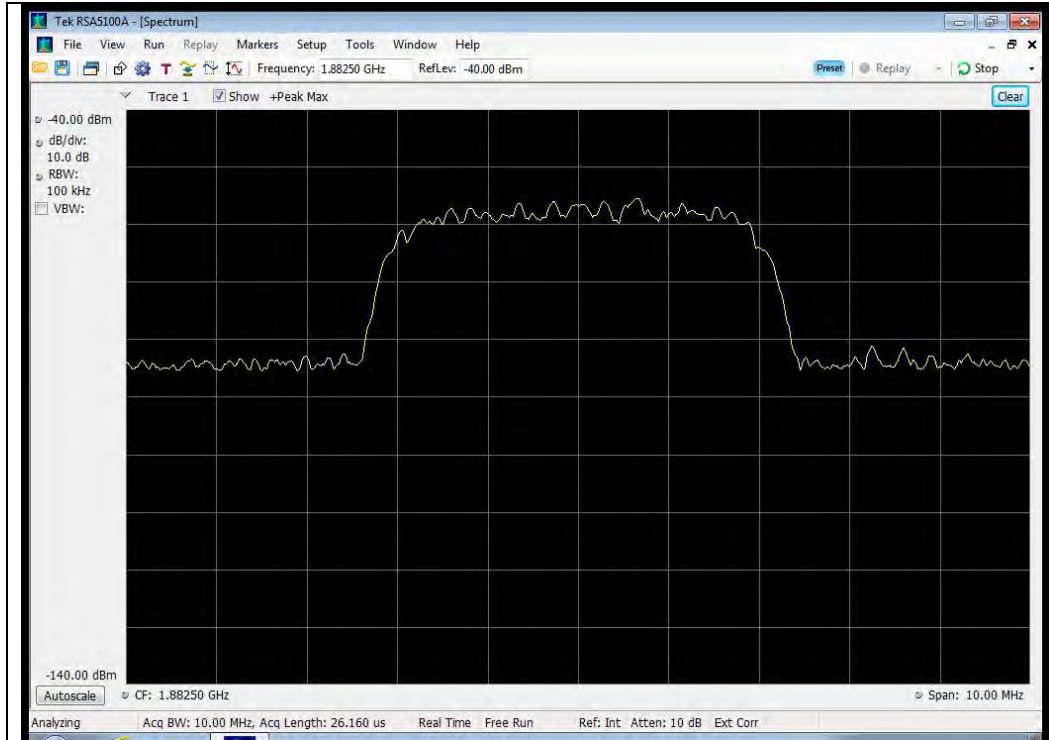

Output

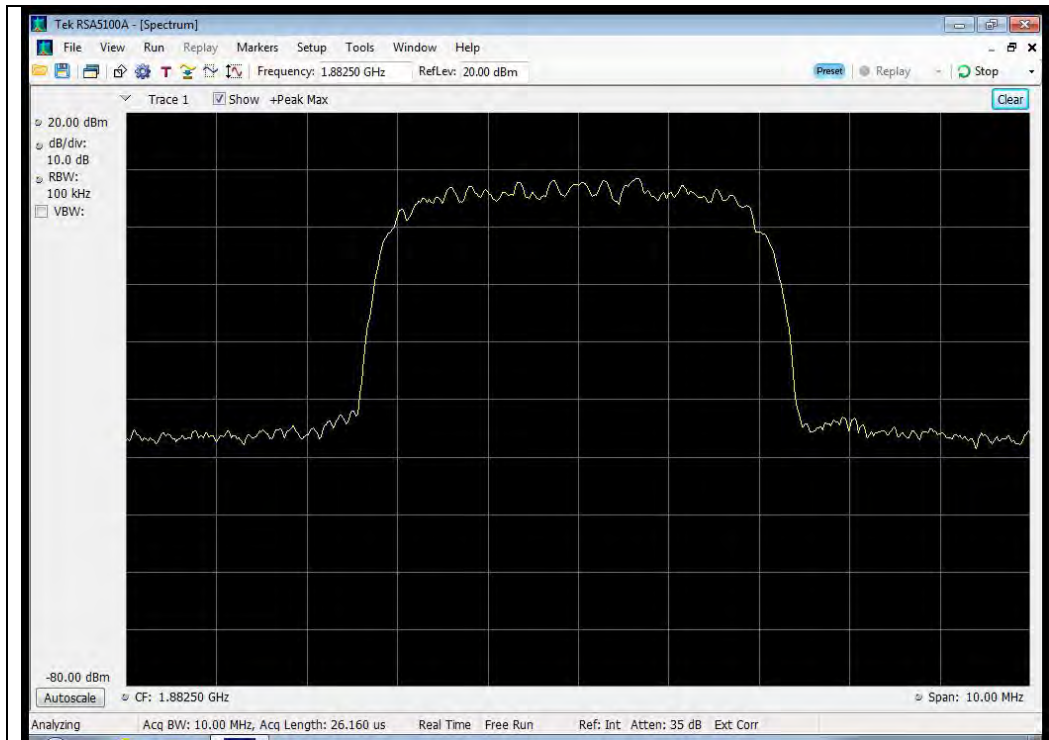

WCDMA Downlink Test Plots

728 - 746 MHz Band

Input

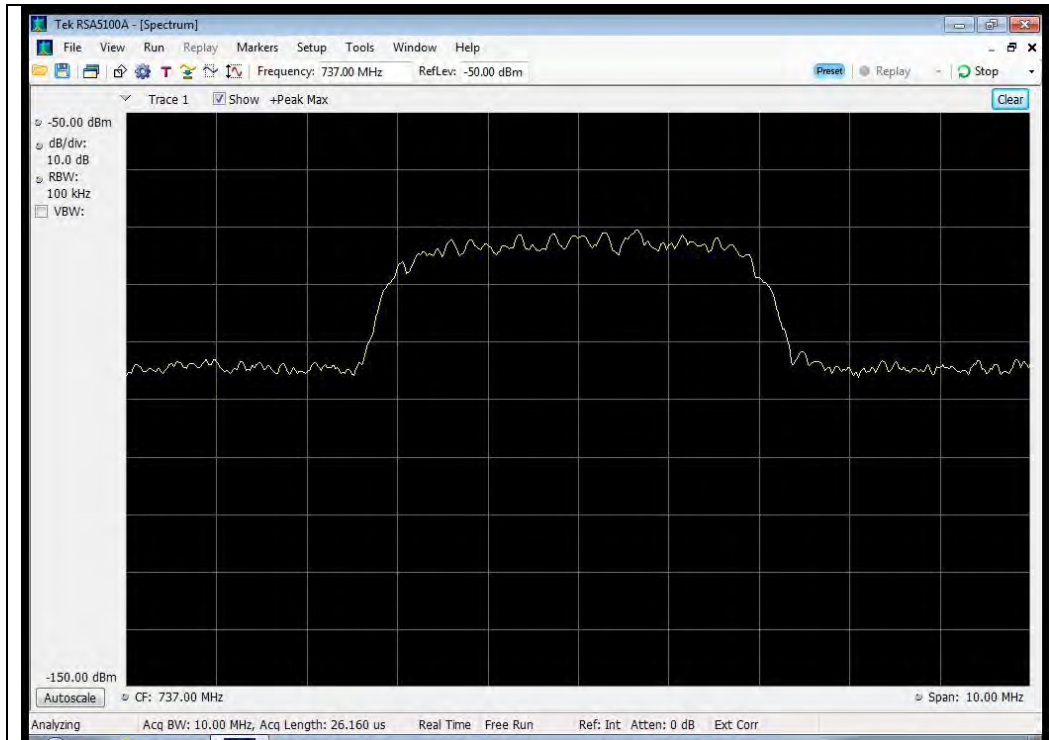

Output

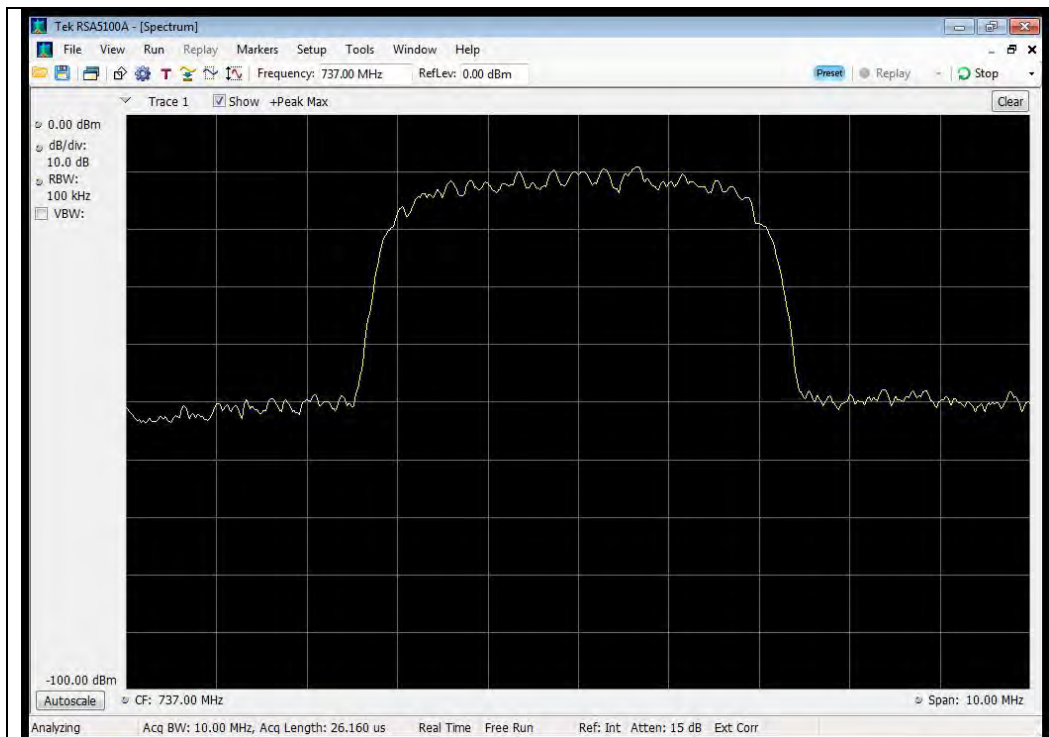

746 - 757 MHz Band

Input

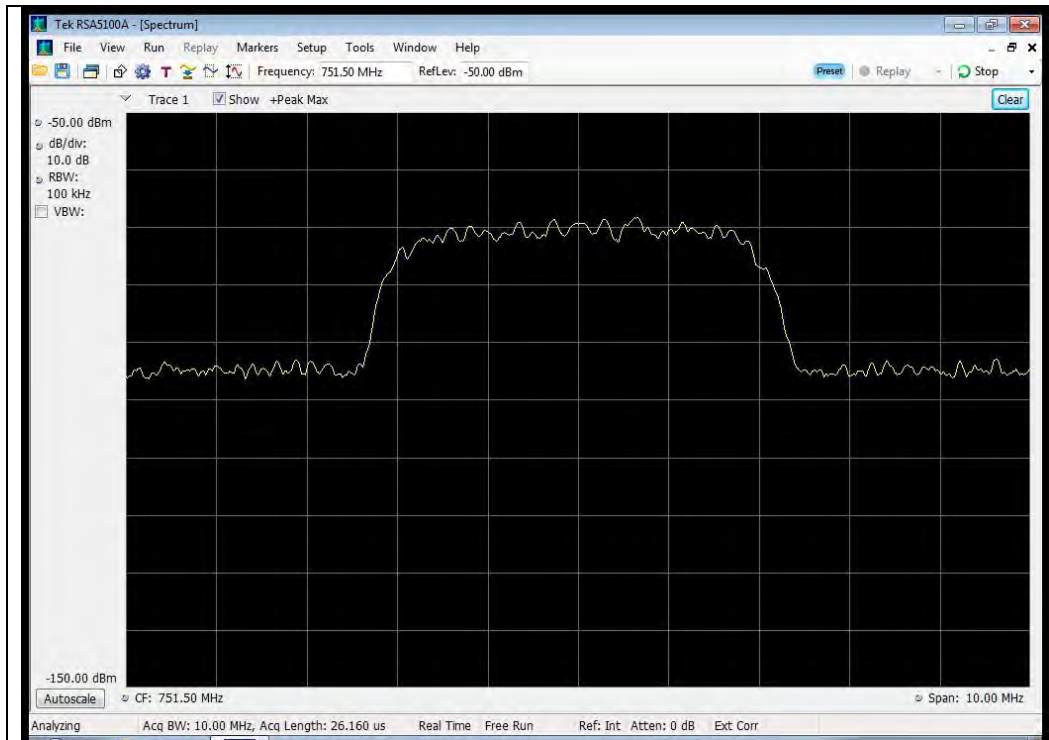

Output

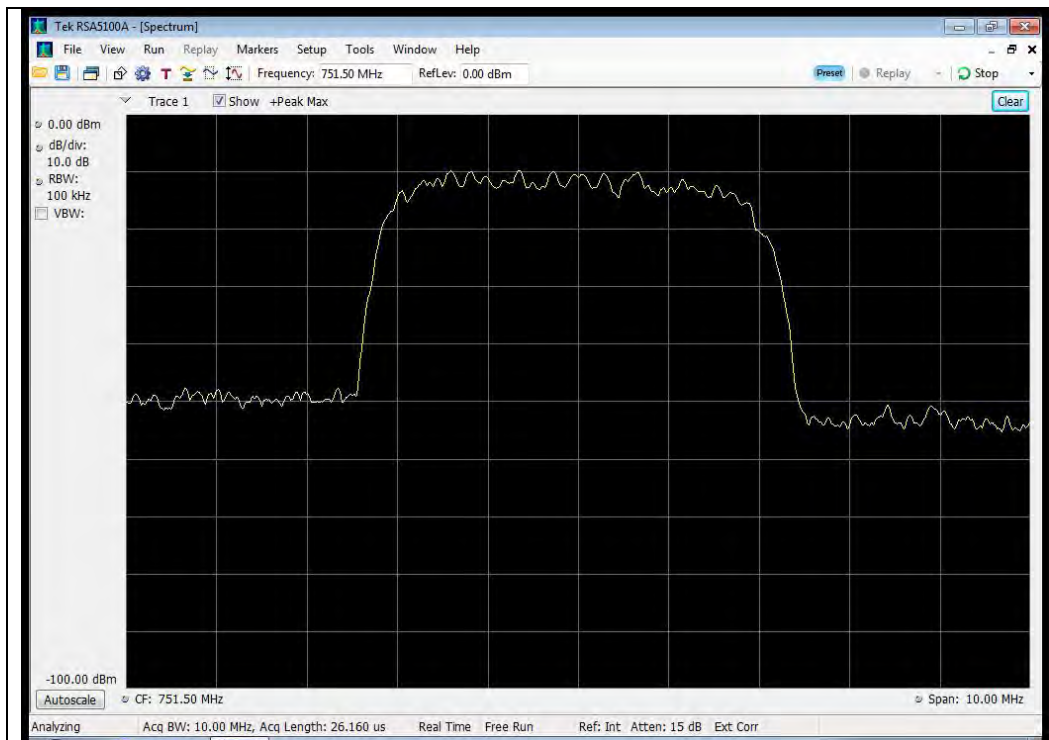

869 - 894 MHz Band

Input

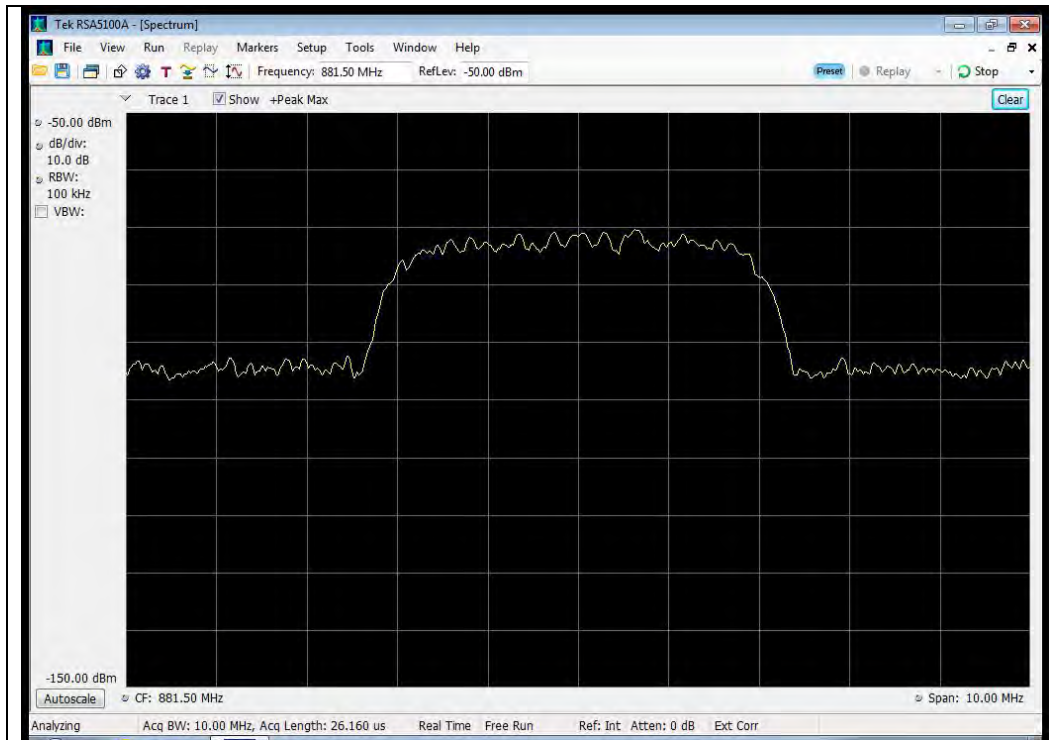

Output

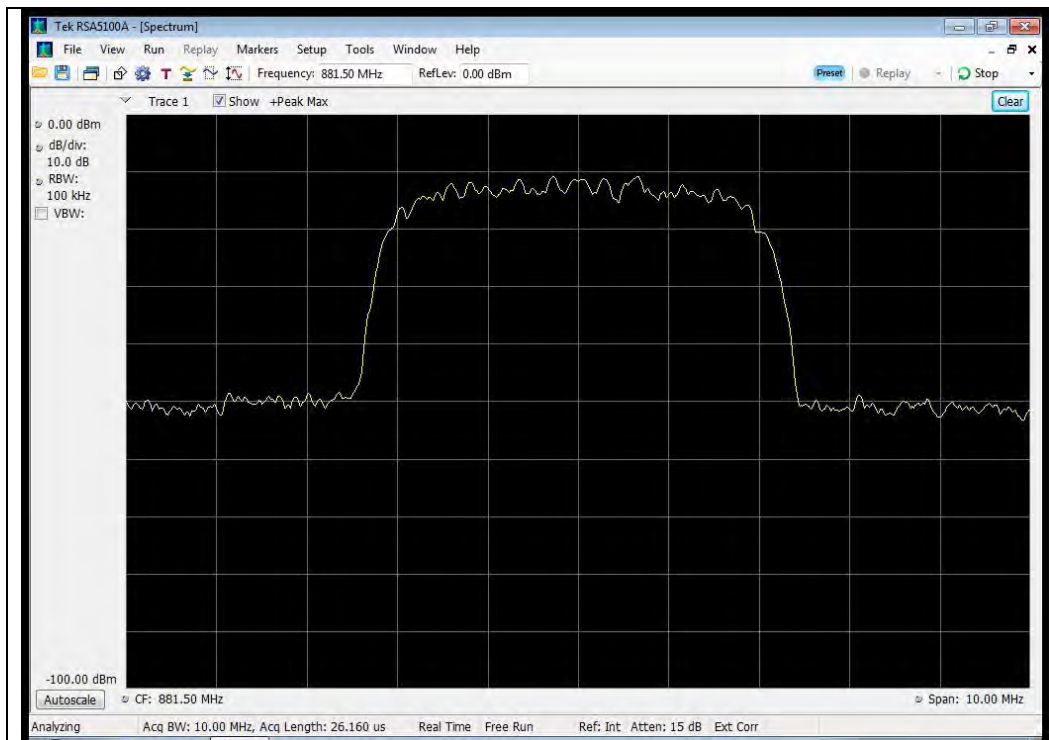

1930 - 1995 MHz Band

Input

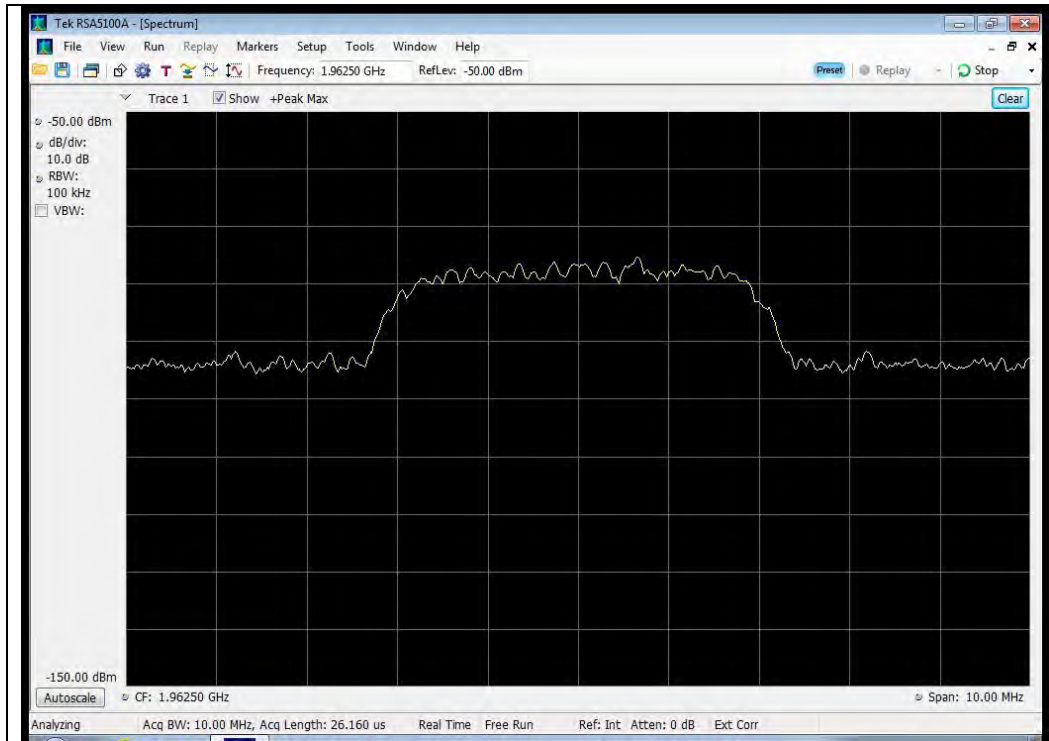

Output

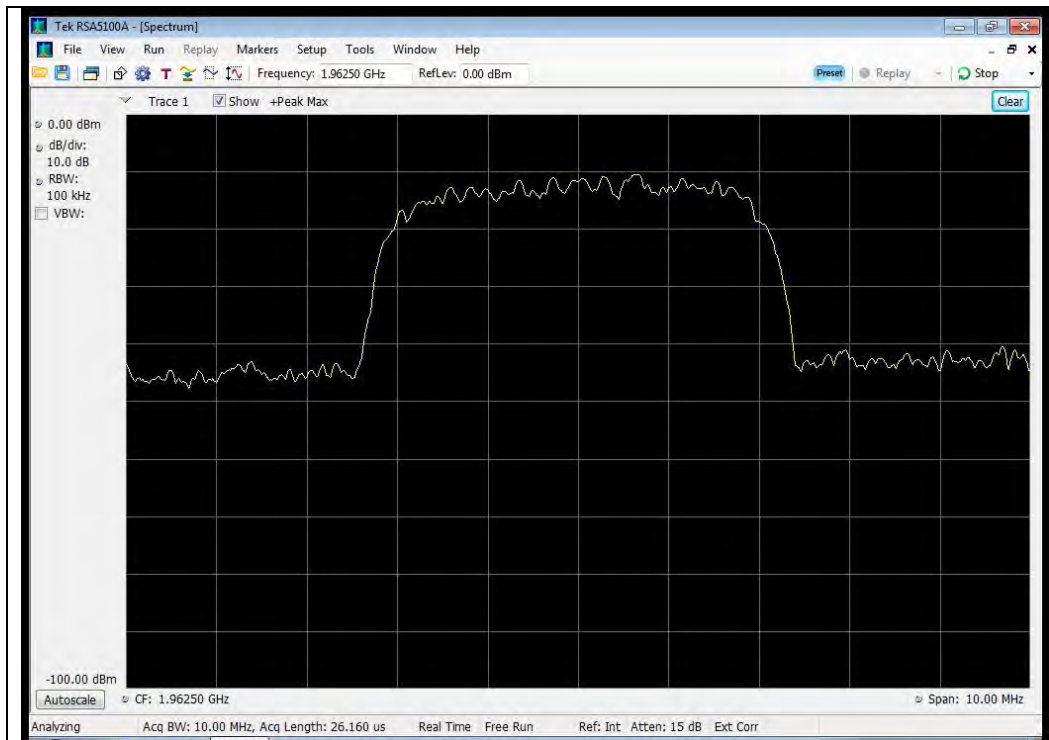

2110 - 2155 MHz Band

Input

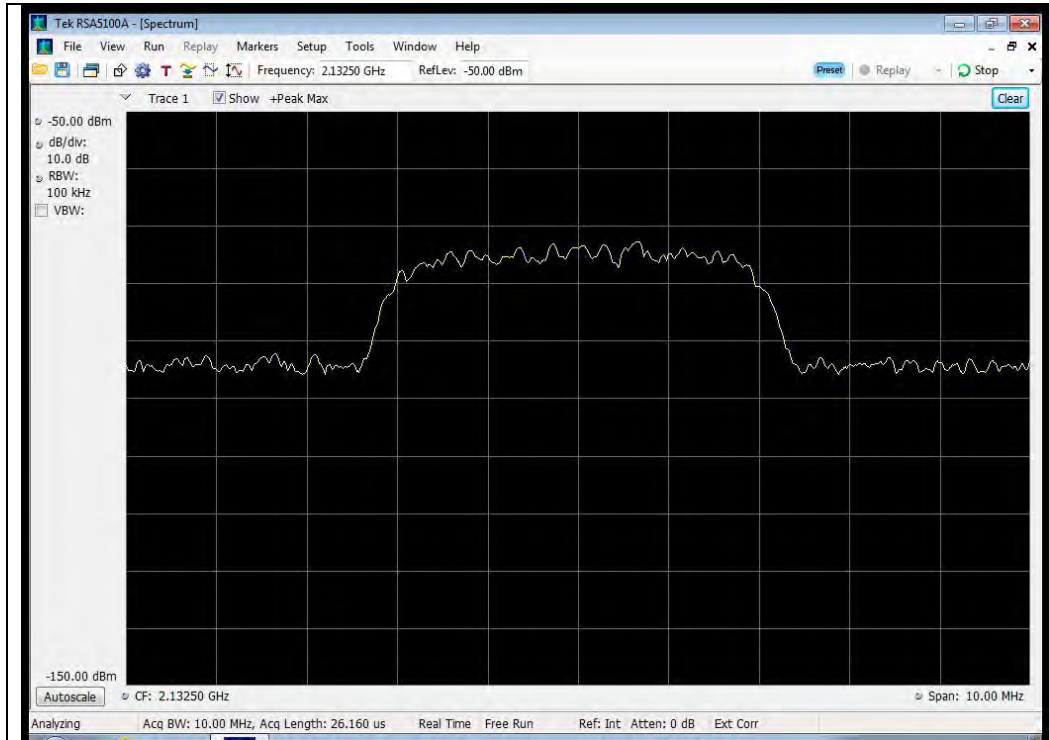

Output

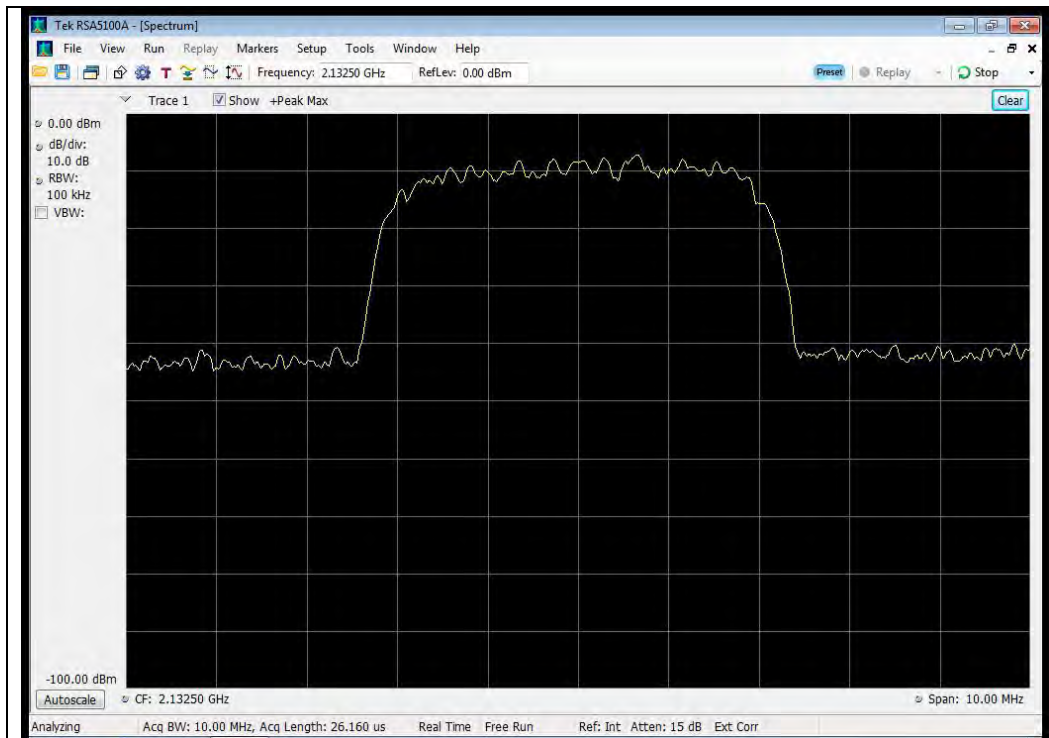

Anti-Oscillation

Engineer: Mike Graffeo

Test Date: 10/28/14

Test Procedure

The EUT was connected to a spectrum analyzer set for 0 Hz operation. The EUT uplink and downlink were fed back upon each other through a selectable band pass filter and variable attenuator. The EUT uplink and downlink were tested to ensure that the presence of oscillation was detected and that the EUT output turned off within 300 mS for the Uplink and 1 second for the Downlink and remained off for 1 minute. A EUT with test software was utilized to ensure that the EUT only had a maximum of 5 attempts at restart from oscillation before permanently shutting off.

Test Setup

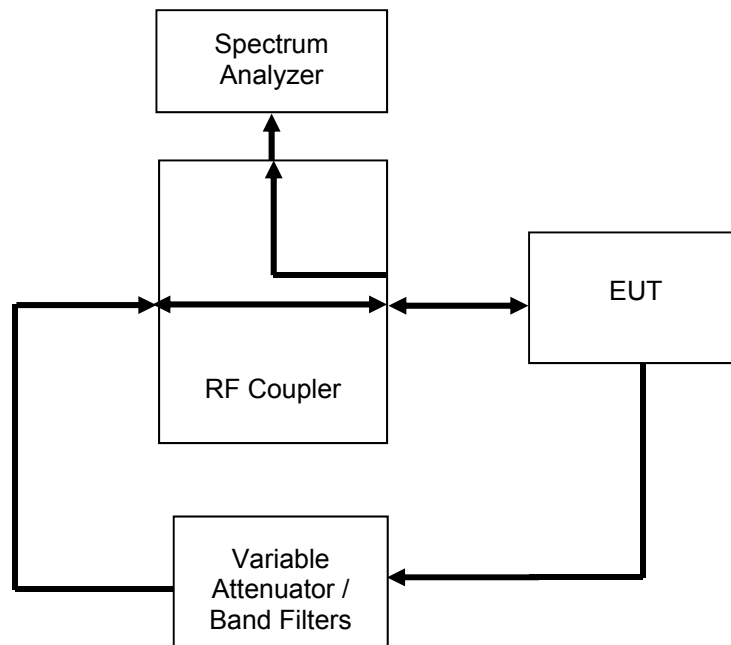

Uplink Detection Time Test Results

Frequency Band (MHz)	Measured Time (mS)	Limit (mS)	Result
698 - 716	118.30	300	Pass
776 - 787	52.25	300	Pass
824 - 849	55.00	300	Pass
1710 - 1755	22.00	300	Pass
1850 - 1915	156.80	300	Pass

Downlink Detection Time Test Results

Frequency Band (MHz)	Measured Time (mS)	Limit (mS)	Result
728 - 746	74.25	1000	Pass
746 - 757	22.00	1000	Pass
869 - 894	195.30	1000	Pass
1930 - 1995	22.00	1000	Pass
2110 - 2155	93.50	1000	Pass

Uplink Restart Time Test Results

Frequency Band (MHz)	Measured Time (S)	Limit (S)	Result
698 - 716	device shut down	≥60	Pass
776 - 787	device shut down	≥60	Pass
824 - 849	device shut down	≥60	Pass
1710 - 1755	device shut down	≥60	Pass
1850 - 1915	69.97	≥60	Pass

Downlink Restart Time Test Results

Frequency Band (MHz)	Measured Time (S)	Limit (S)	Result
728 - 746	device shut down	≥60	Pass
746 - 757	device shut down	≥60	Pass
869 - 894	device shut down	≥60	Pass
1930 - 1995	69.52	≥60	Pass
2110 - 2155	70.2	≥60	Pass

Uplink Restart Count Test Results

Frequency Band (MHz)	Restarts	Limit	Result
698 - 716	0	≤5	Pass
776 - 787	0	≤5	Pass
824 - 849	0	≤5	Pass
1710 - 1755	0	≤5	Pass
1850 - 1915	3	≤5	Pass

Downlink Restart Count Test Results

Frequency Band (MHz)	Restarts	Limit	Result
728 - 746	0	≤5	Pass
746 - 757	0	≤5	Pass
869 - 894	0	≤5	Pass
1930 - 1995	4	≤5	Pass
2110 - 2155	4	≤5	Pass

Uplink Detection Time Test Results

698 - 716 MHz Band

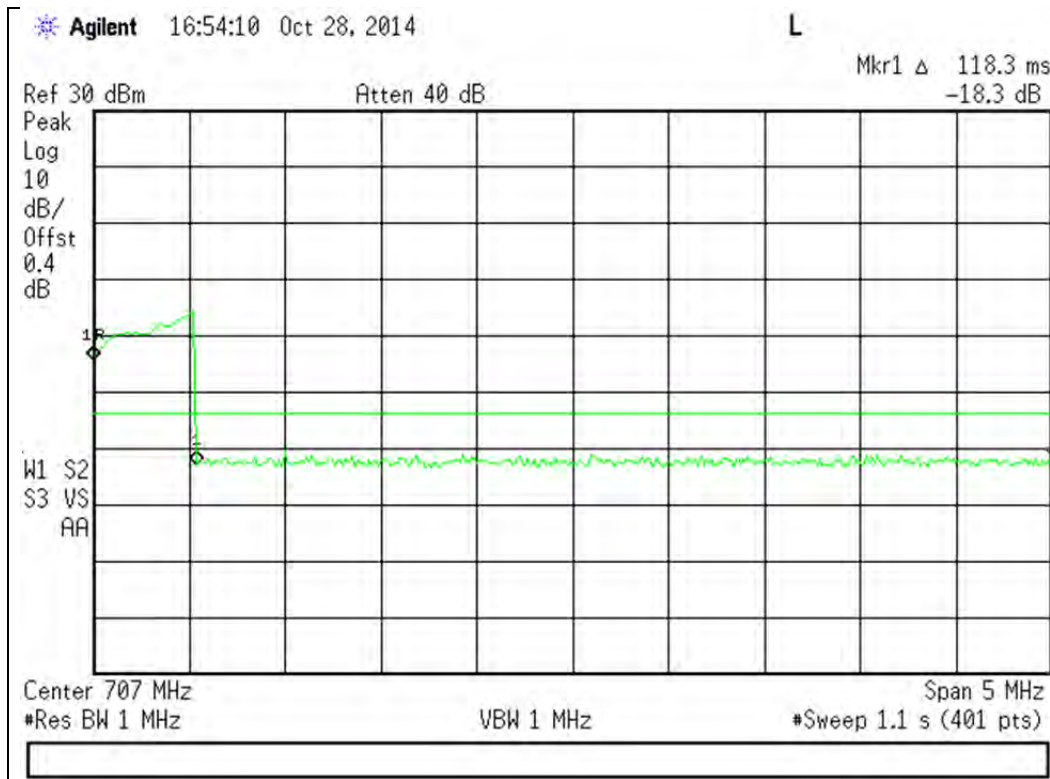

776 - 787 MHz Band

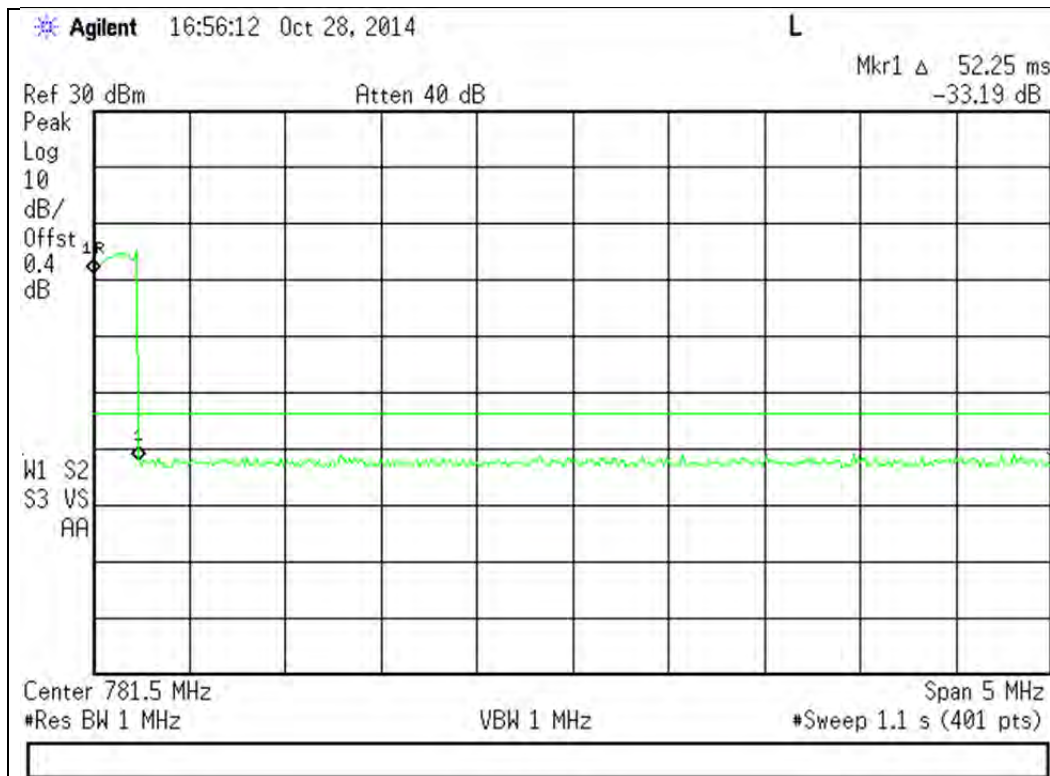

824 - 849 MHz Band

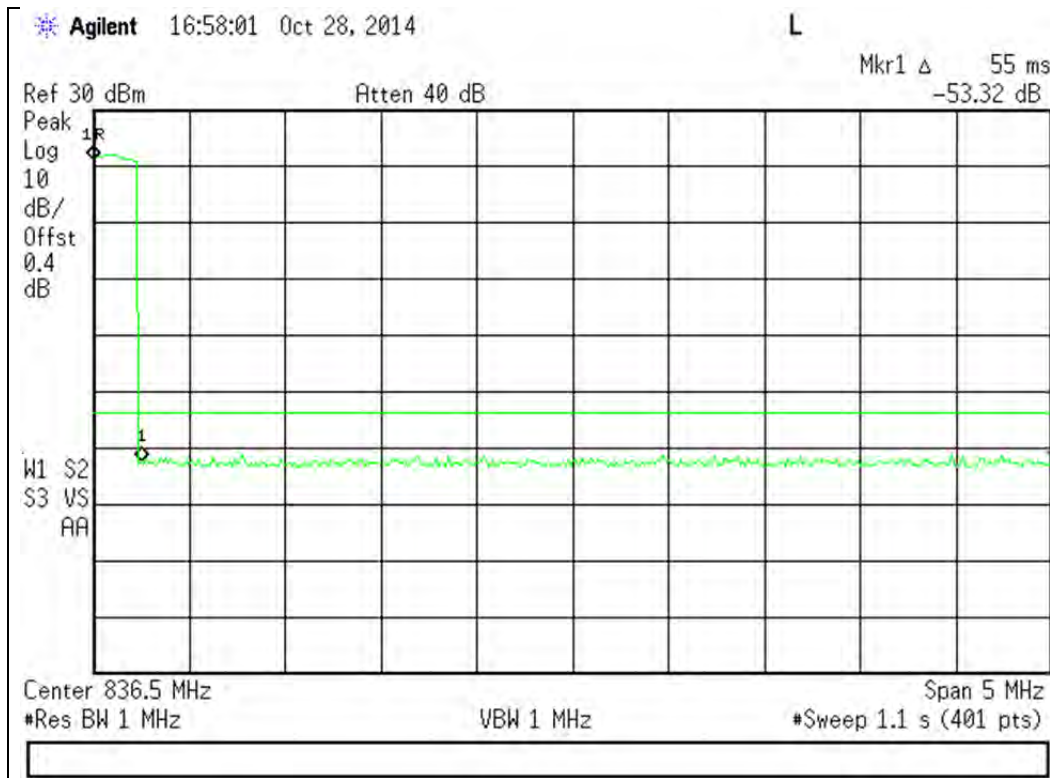

1710 - 1755 MHz Band

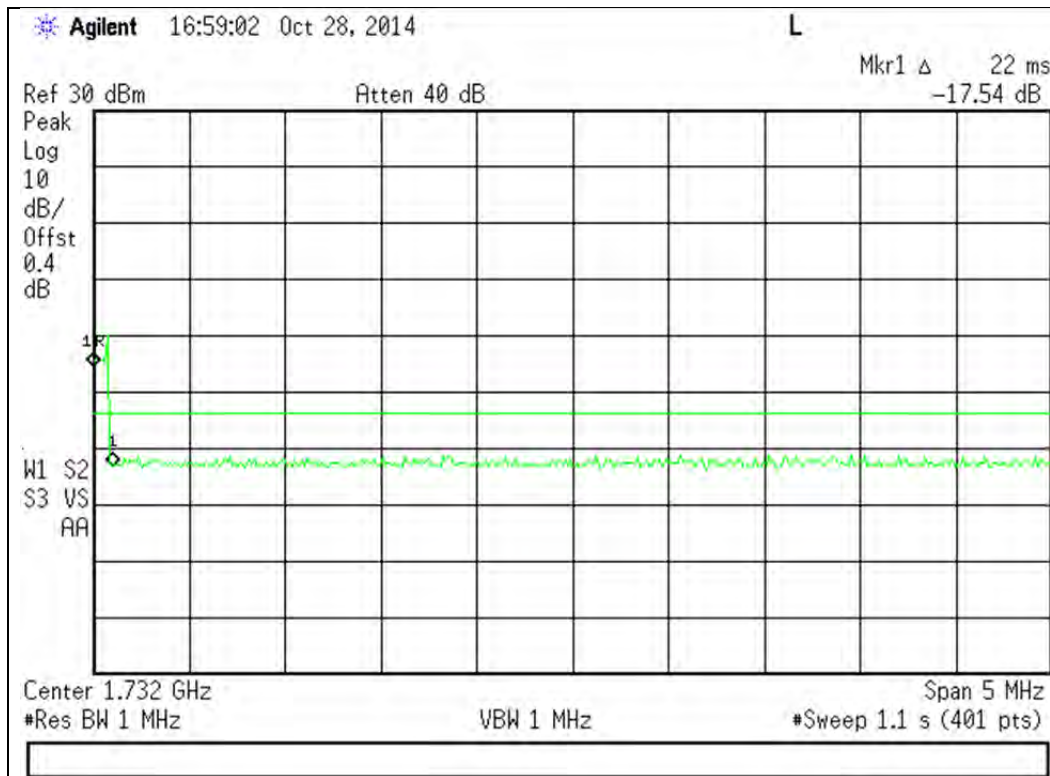

1850 - 1915 MHz Band

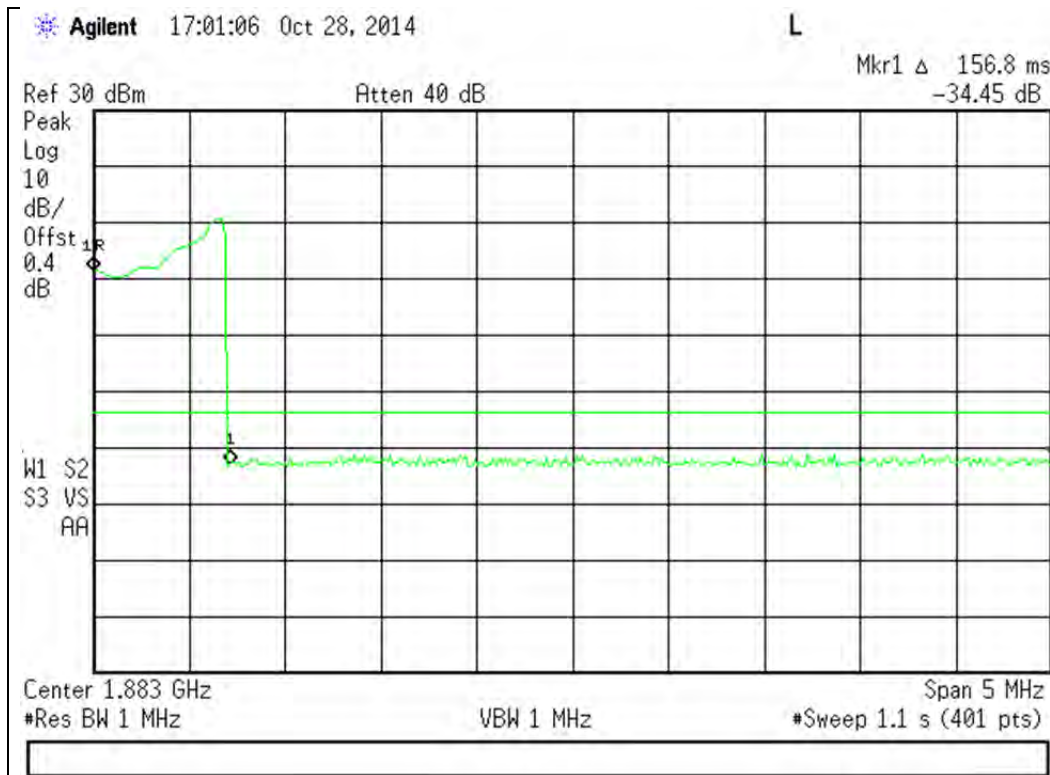

Uplink Restart Time Test Results

698 - 716 MHz Band

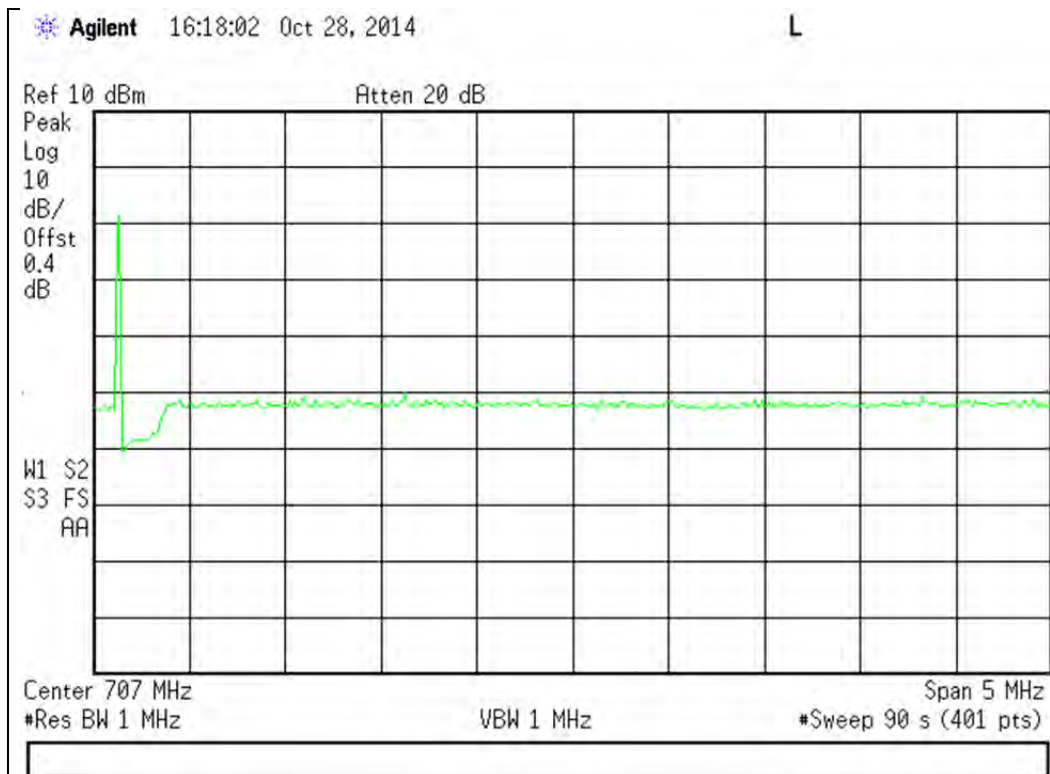

776 - 787 MHz Band

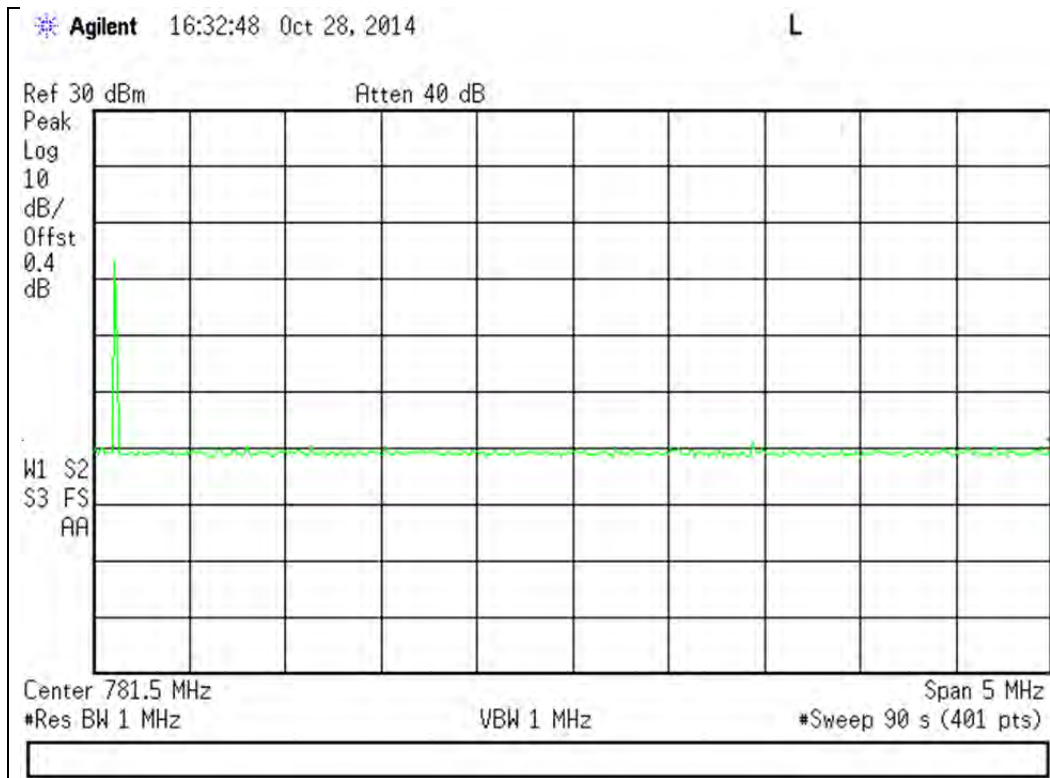

824 - 849 MHz Band

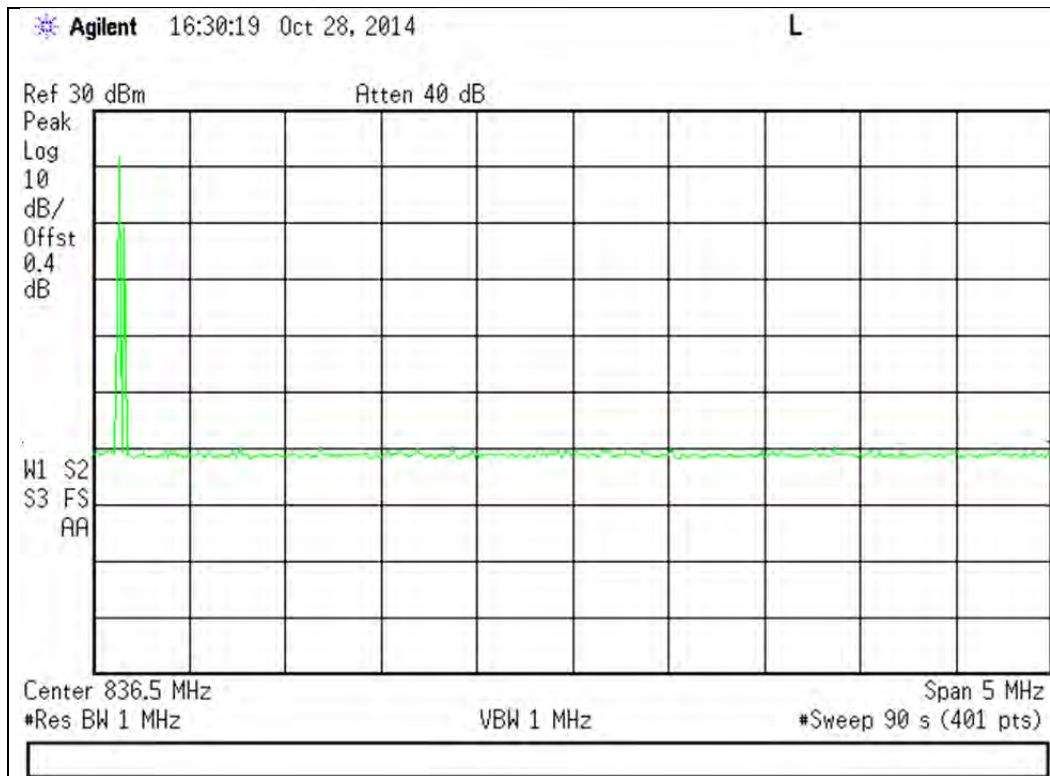

1710 - 1755 MHz Band

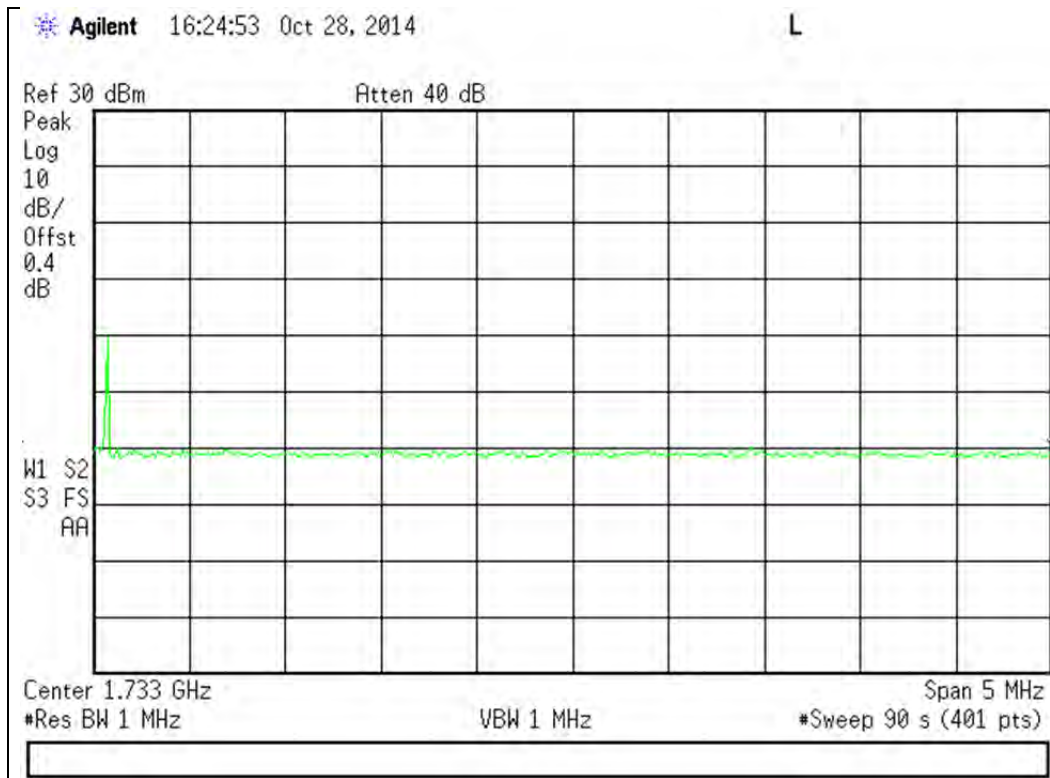

1850 - 1915 MHz Band

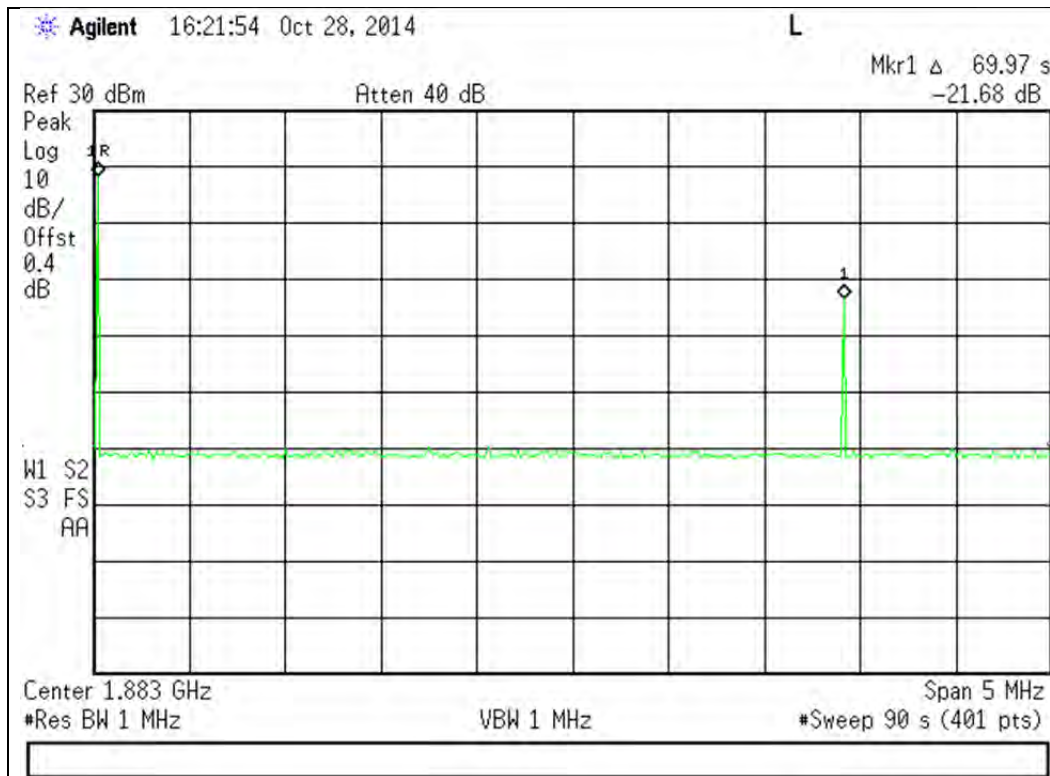

Uplink Restart Count Test Results

698 - 716 MHz Band

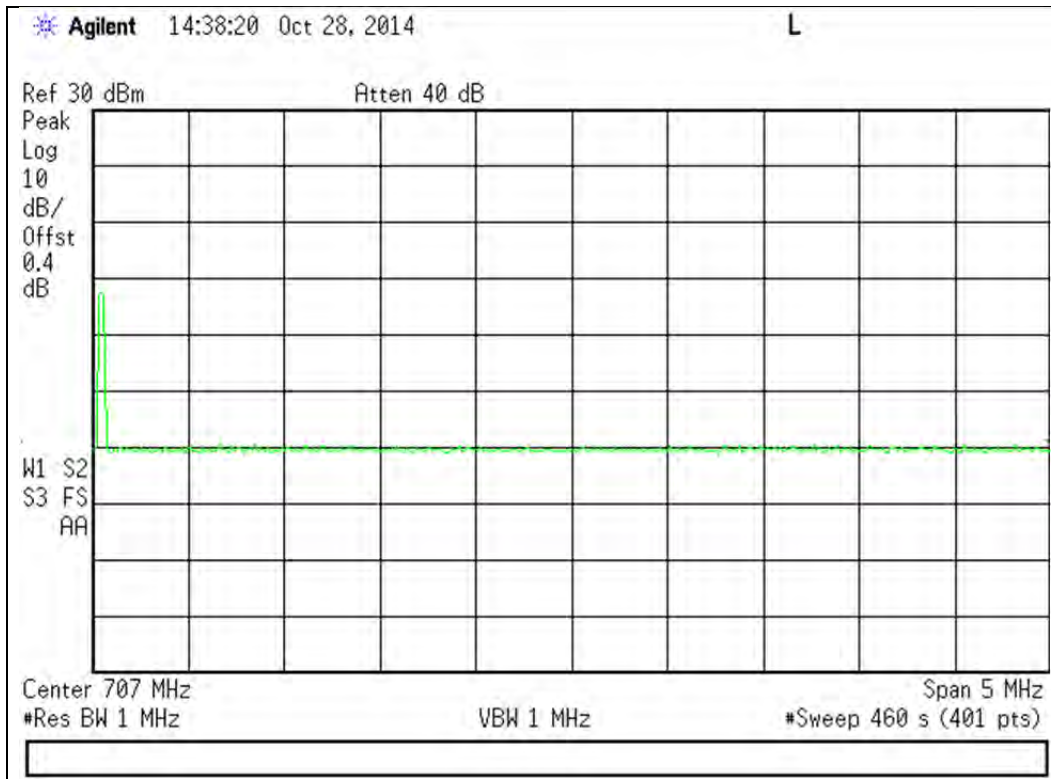

776 - 787 MHz Band

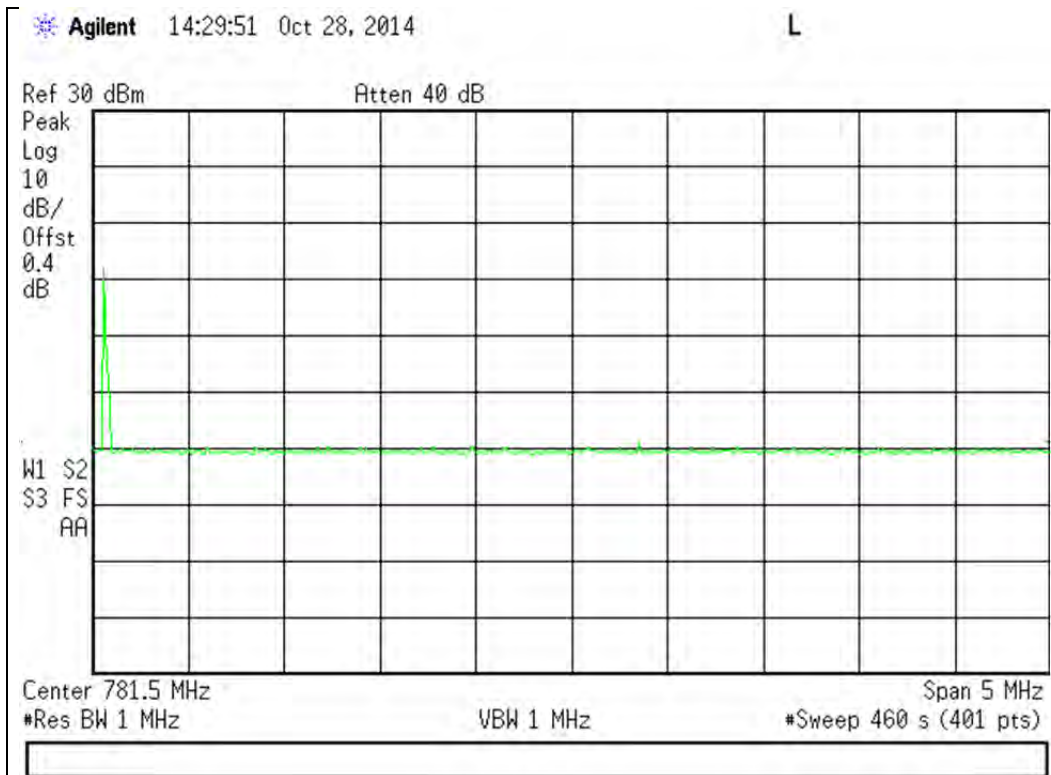

824 - 849 MHz Band

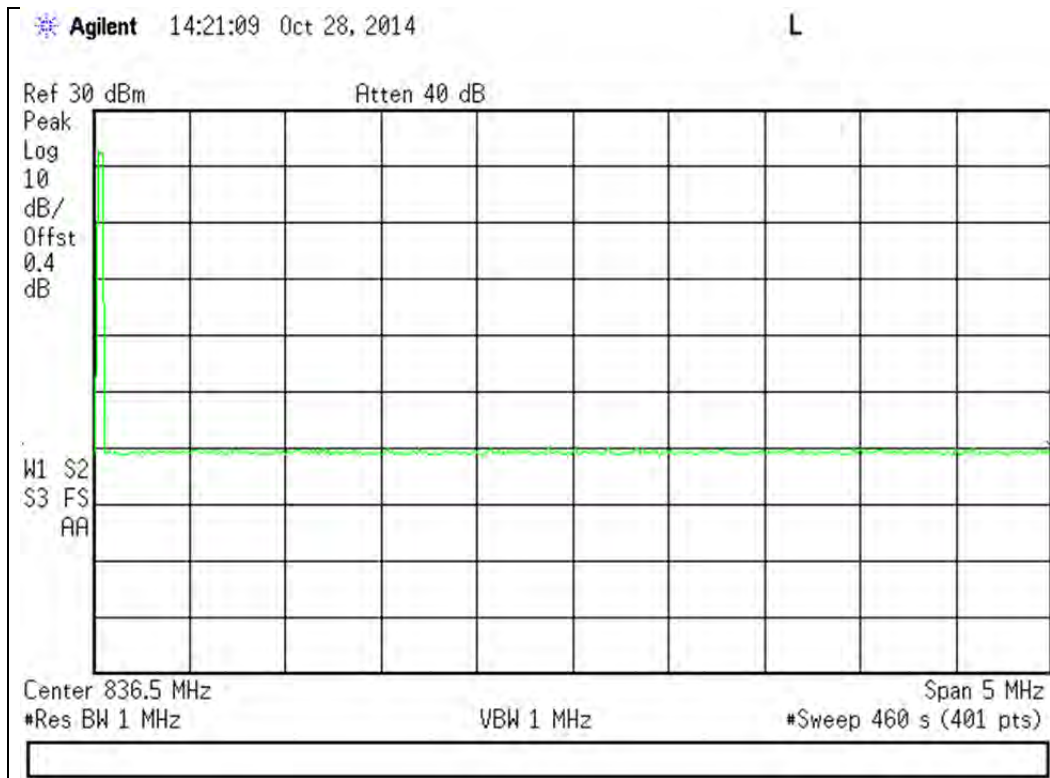

1710 - 1755 MHz Band

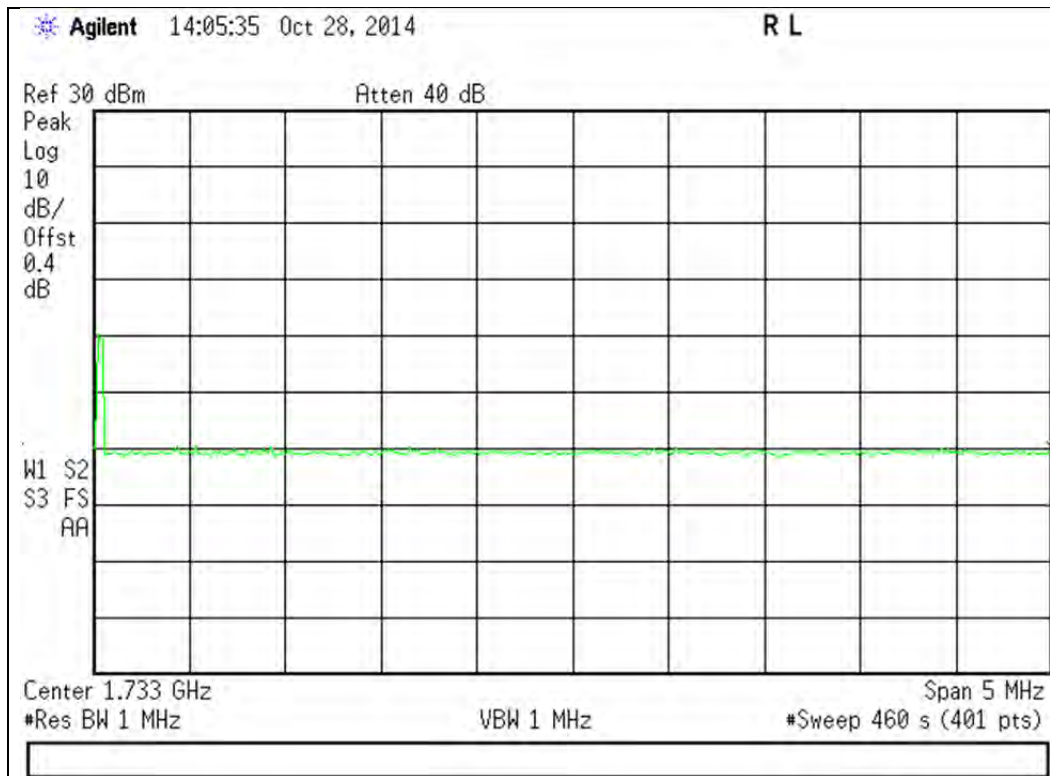

1850 - 1915 MHz Band

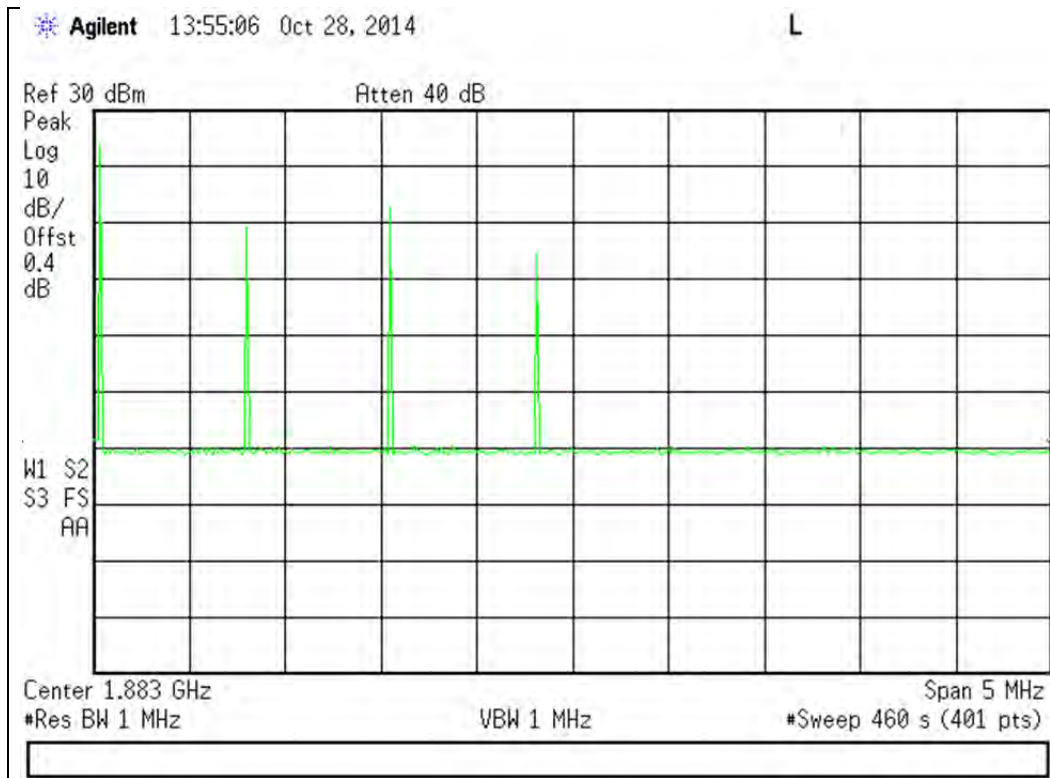

Downlink Detection Time Test Results

728 - 746 MHz Band

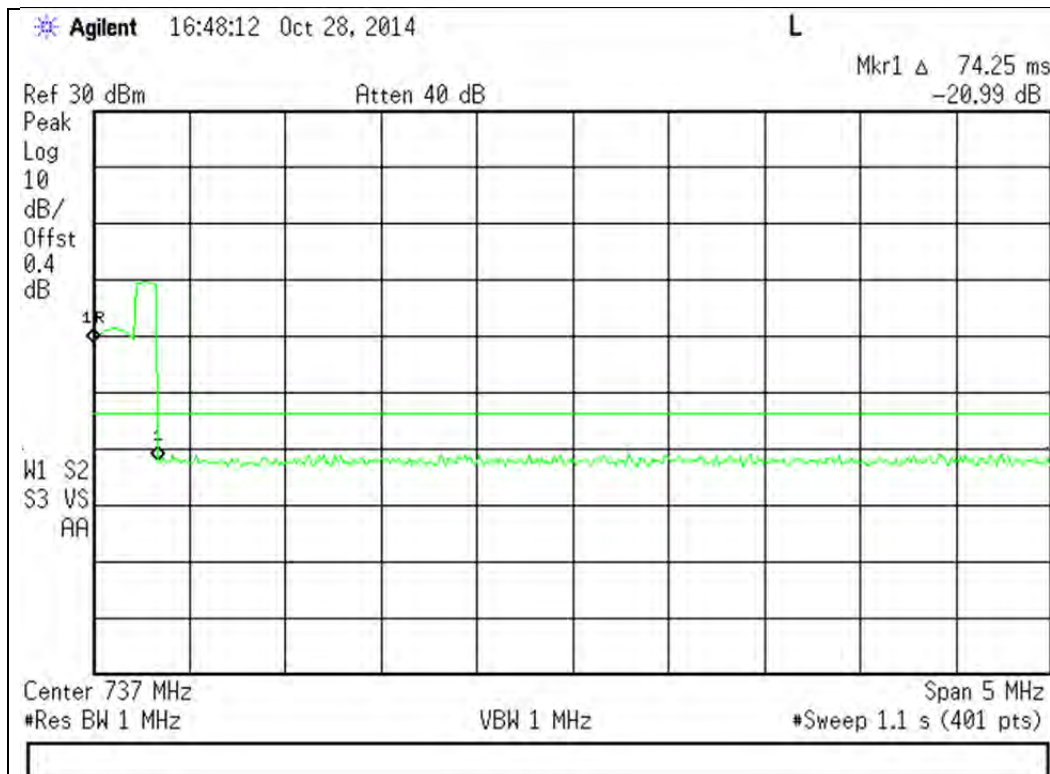

746 - 757 MHz Band

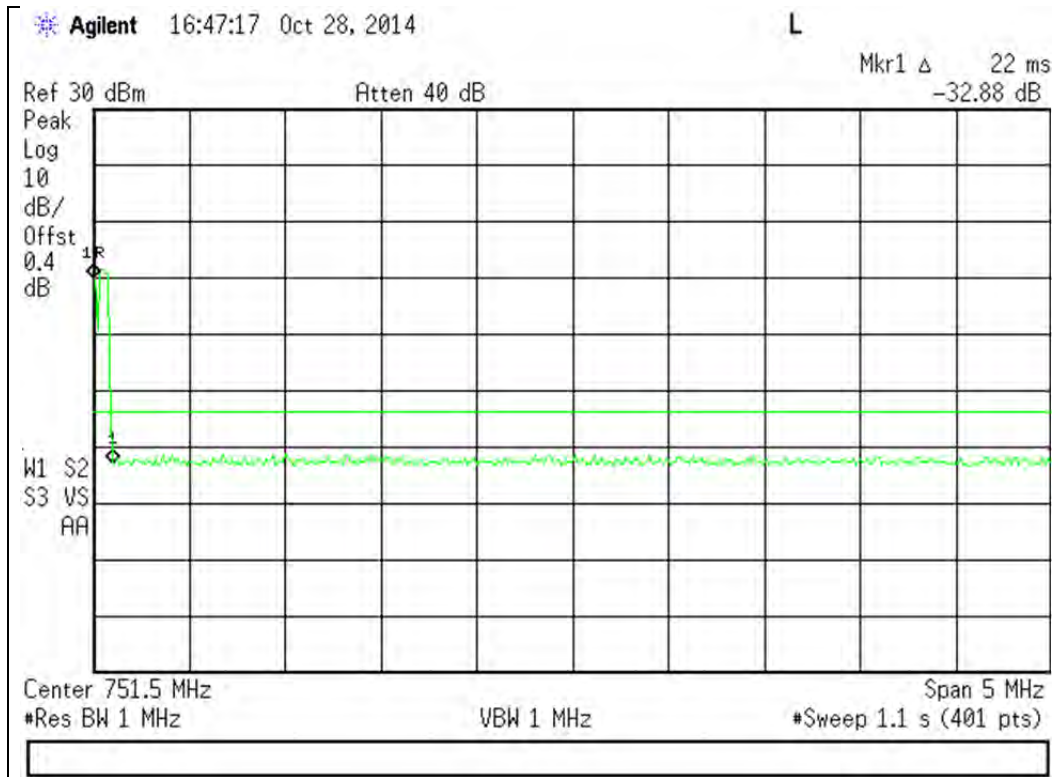

869 - 894 MHz Band

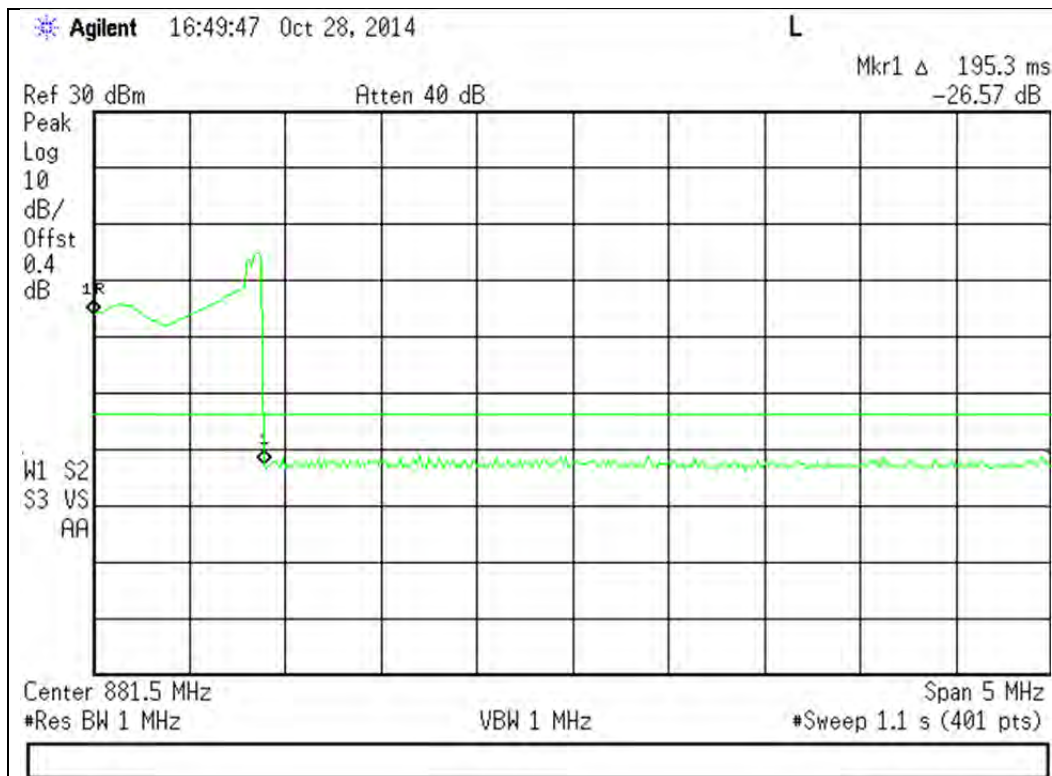

1930 - 1995 MHz Band

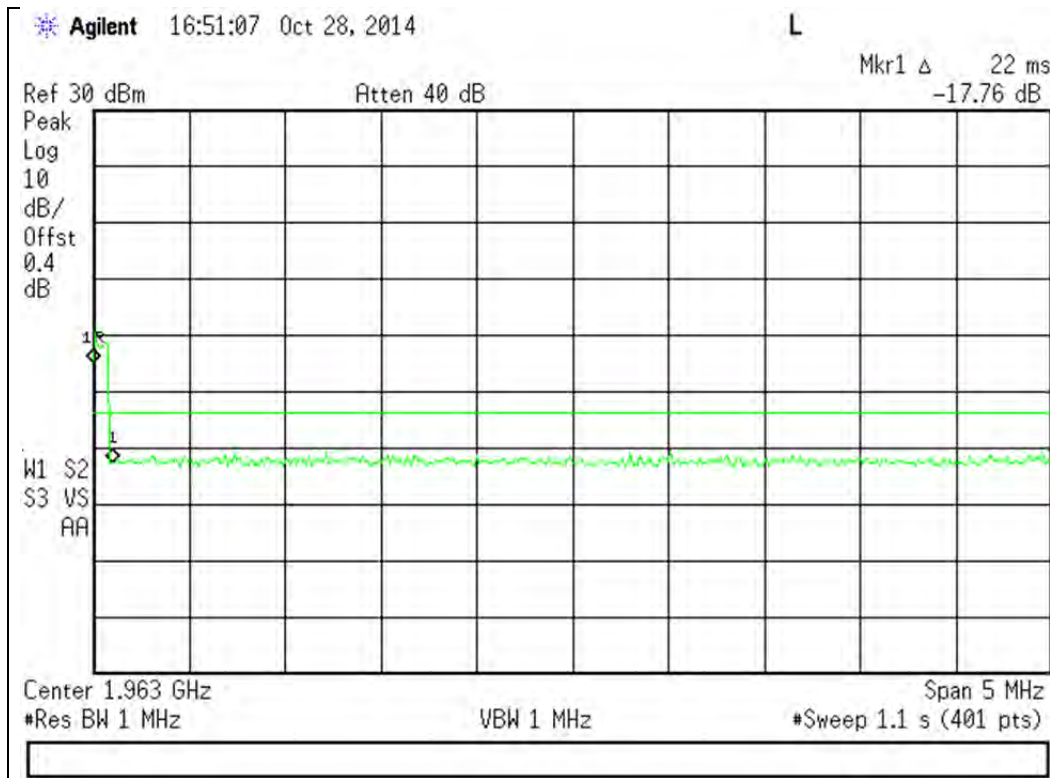

2110 - 2155 MHz Band

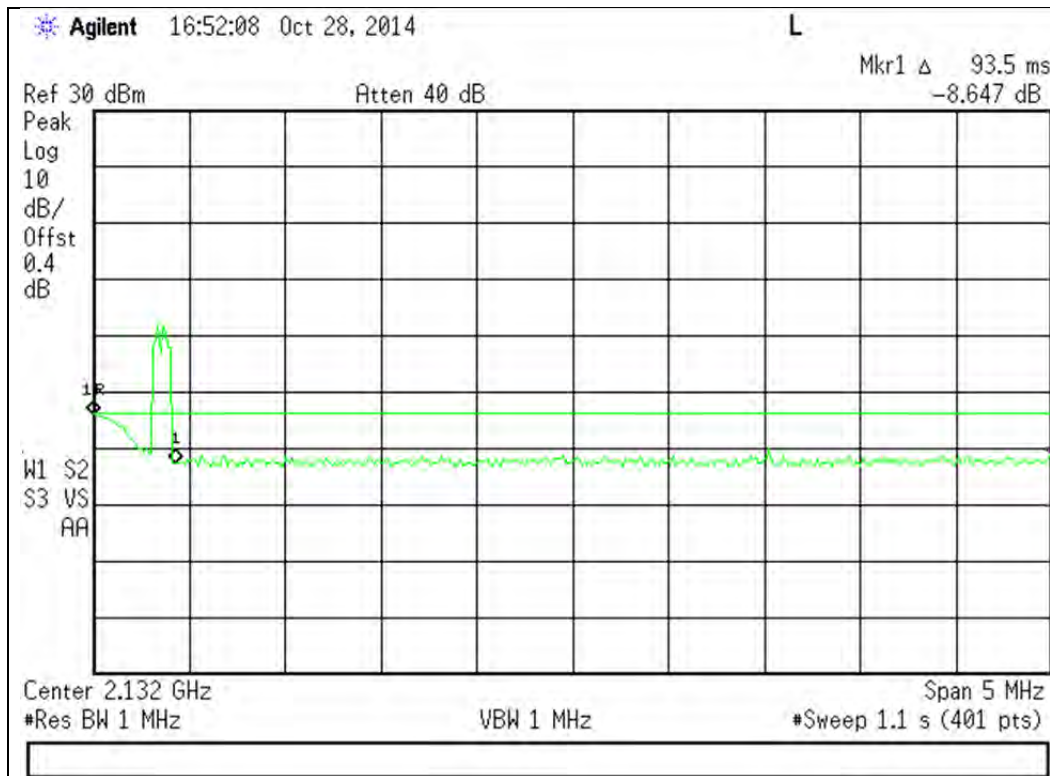

Downlink Restart Time Test Results

728 - 746 MHz Band

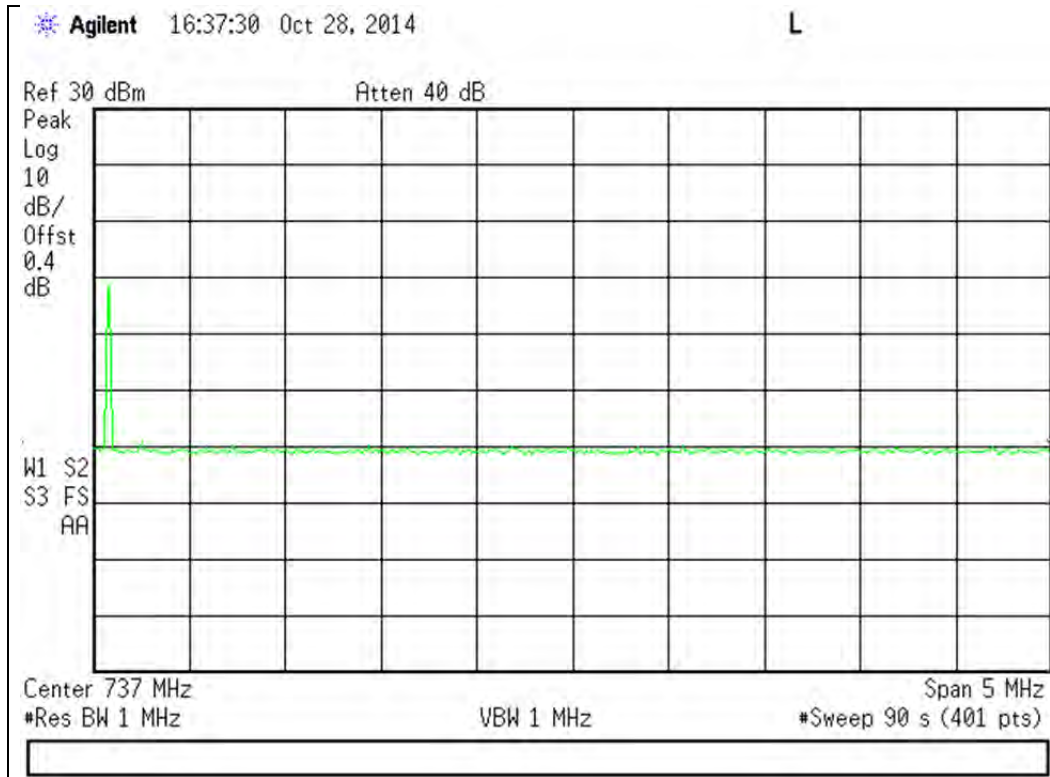

746 - 757 MHz Band

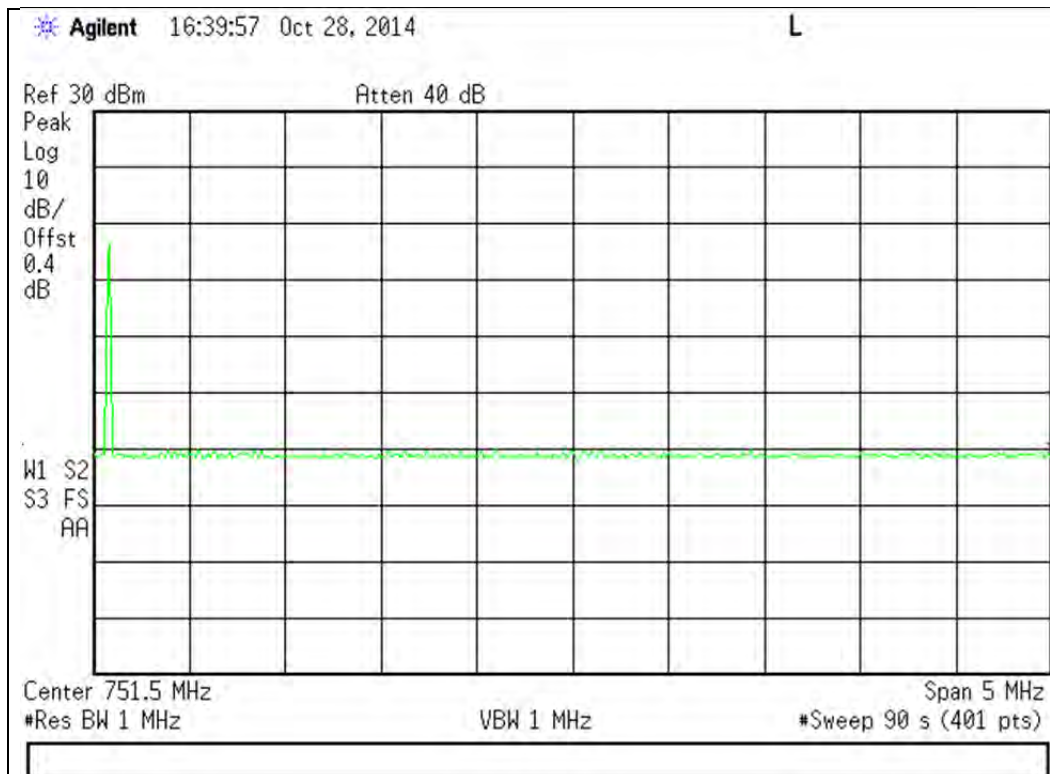

869 - 894 MHz Band

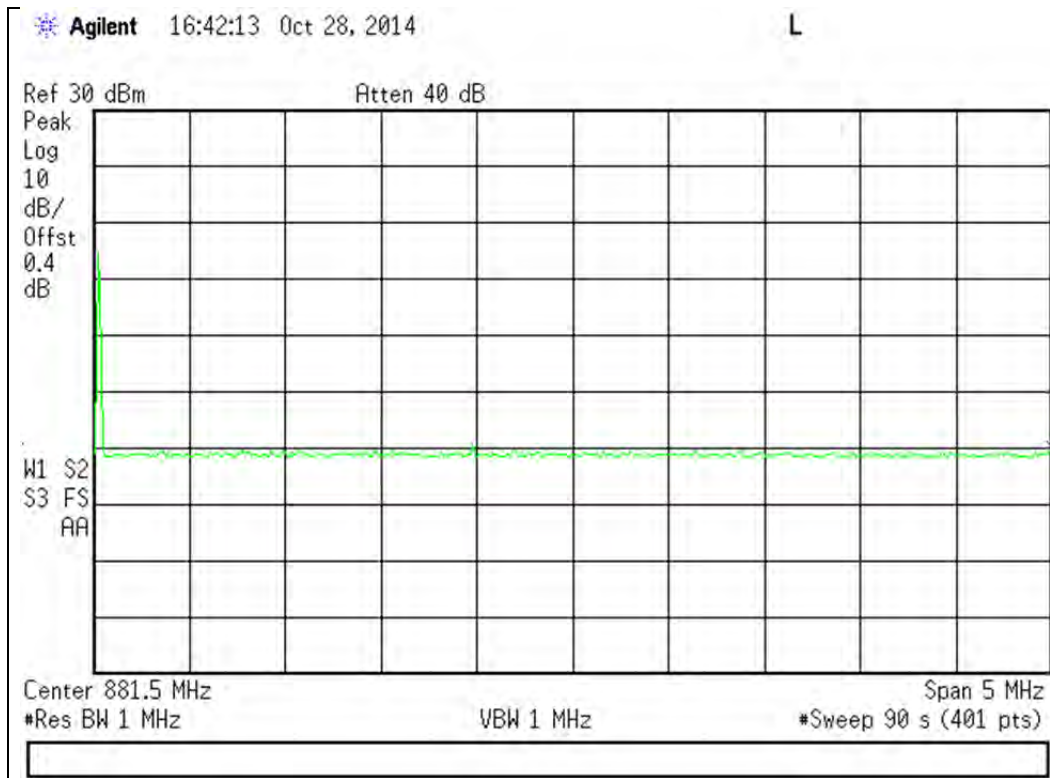

1930 - 1995 MHz Band

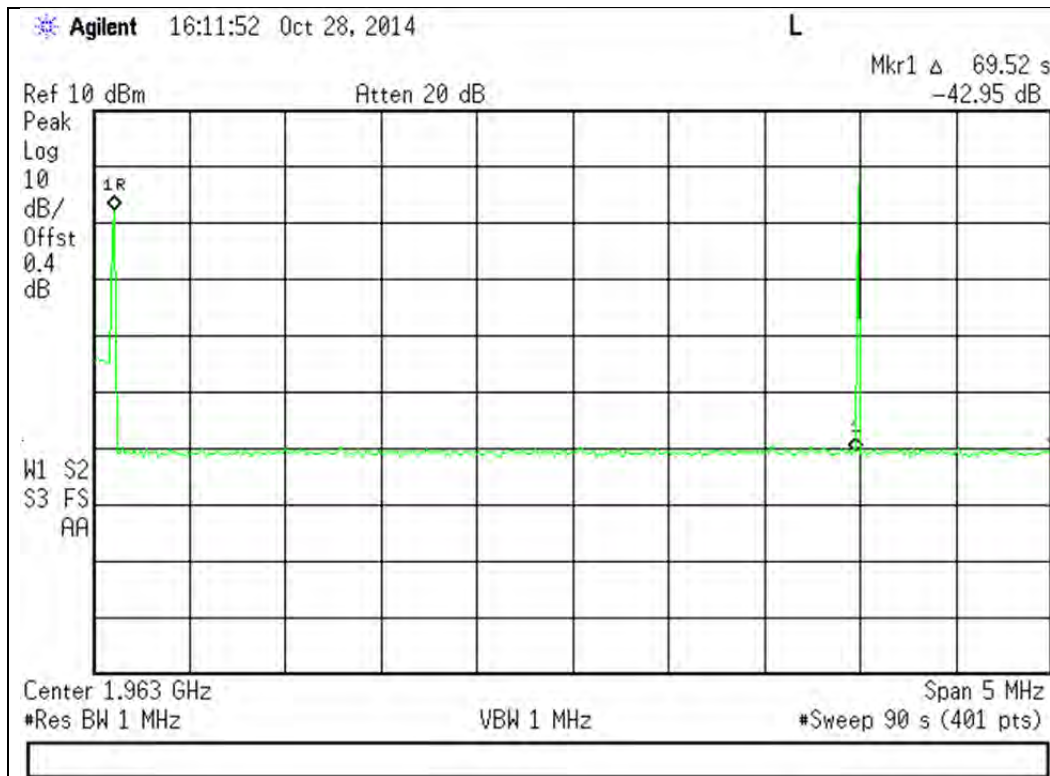

2110 - 2155 MHz Band

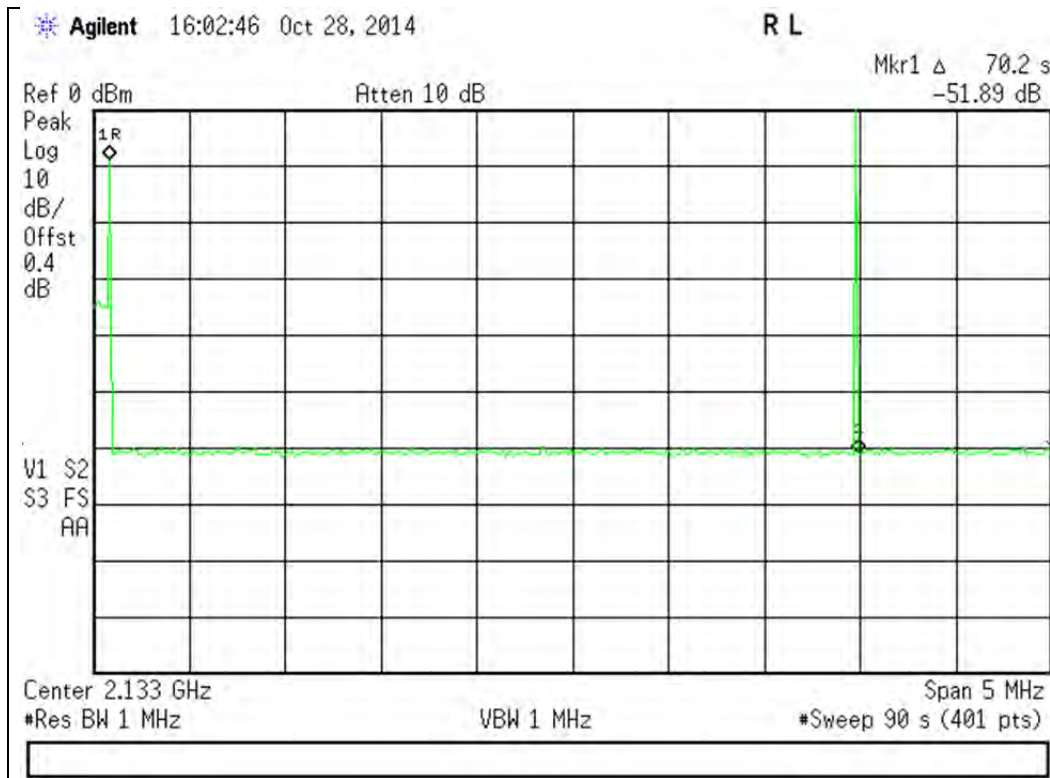

Downlink Restart Count Test Results

728 - 746 MHz Band

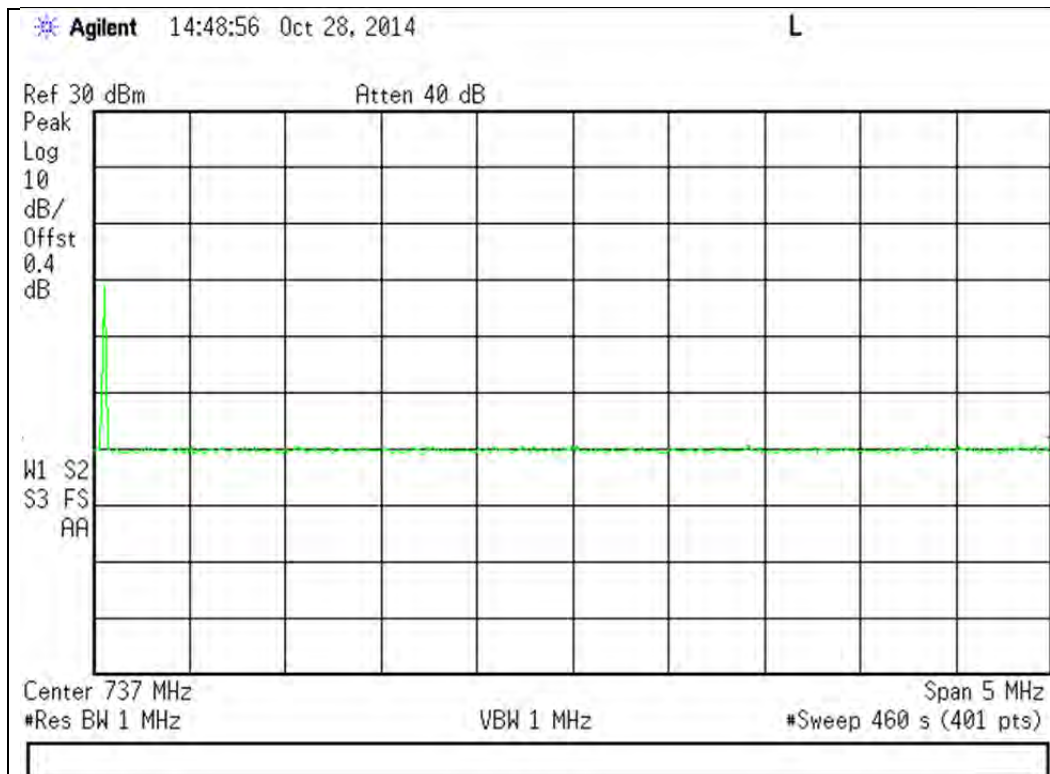

746 - 757 MHz Band

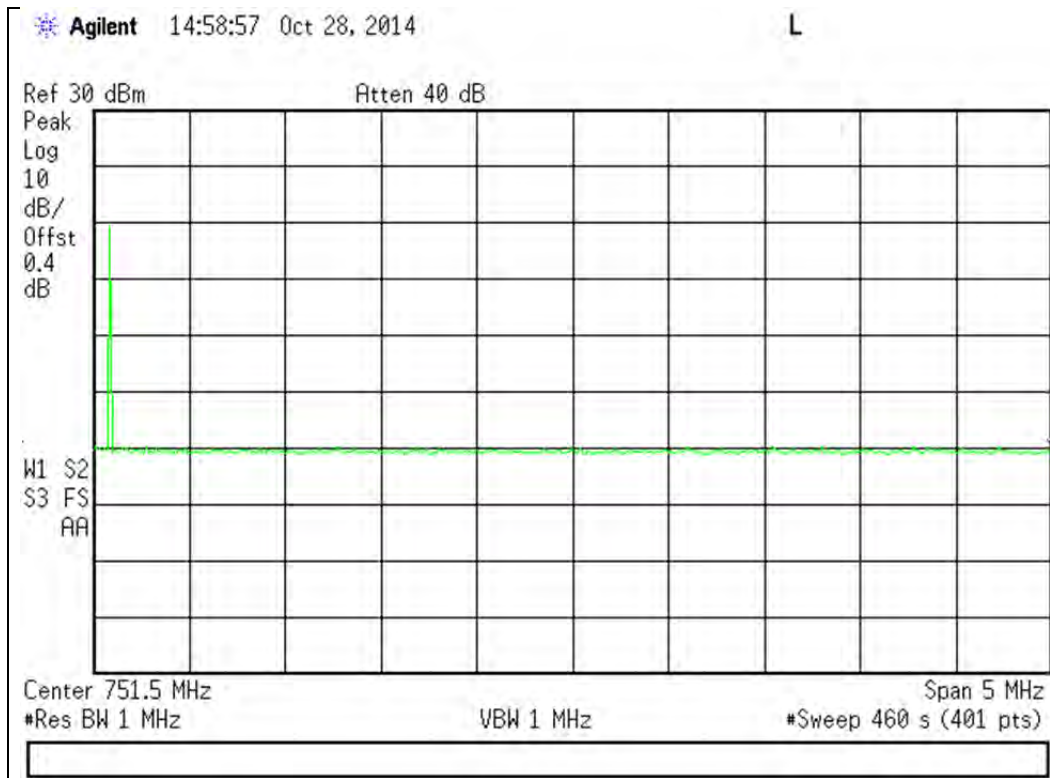

869 - 894 MHz Band

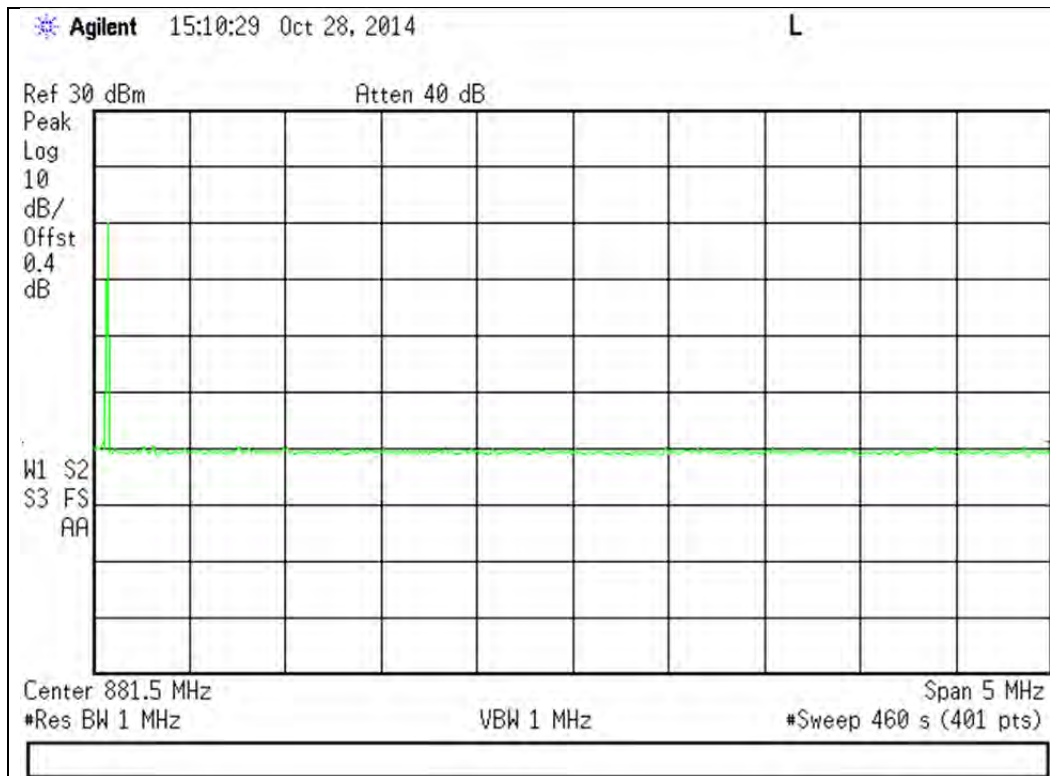

1930 - 1995 MHz Band

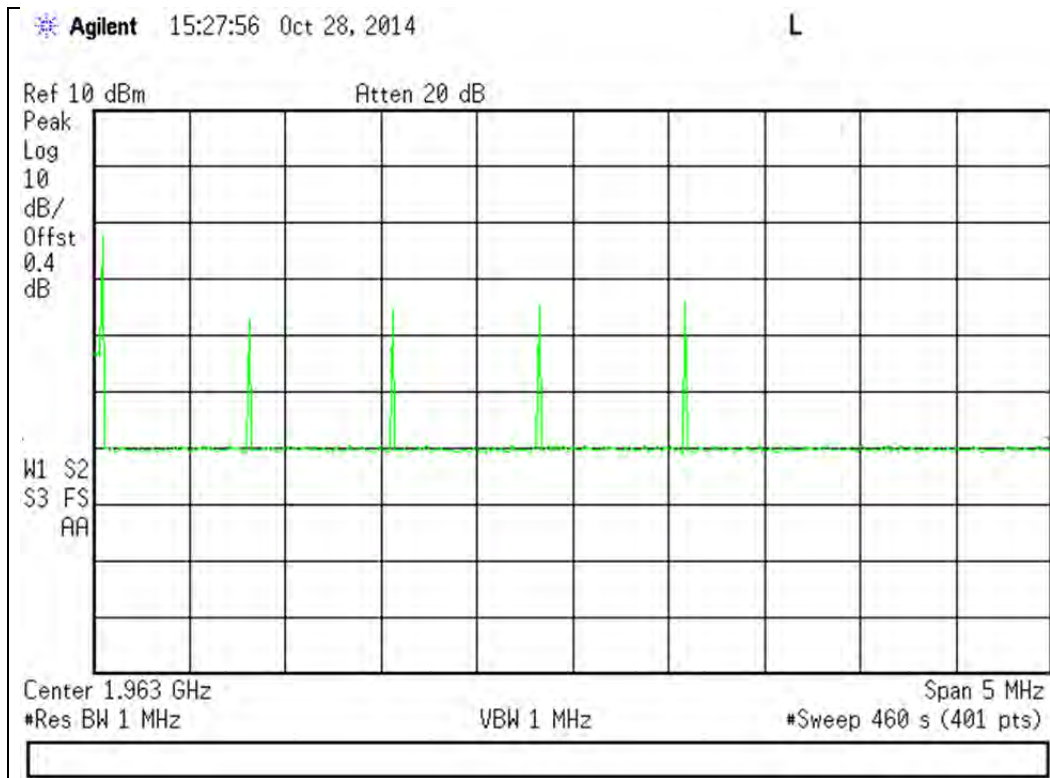

2110 - 2155 MHz Band

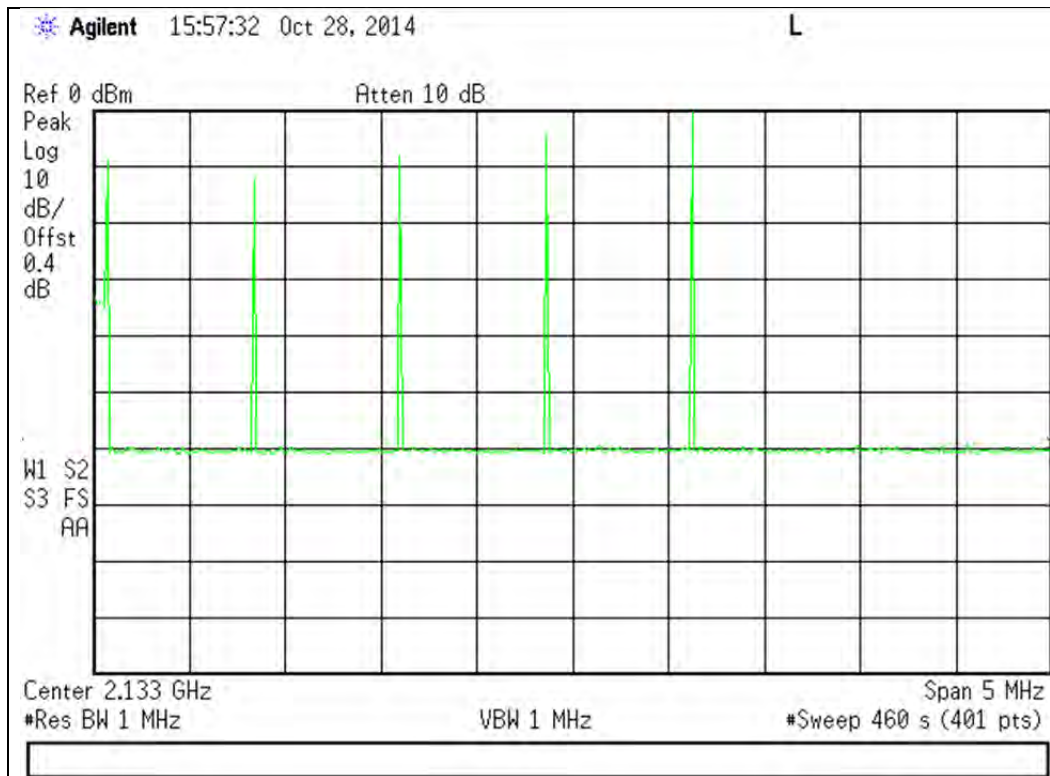

Oscillation Mitigation

Engineer: Greg Corbin

Test Date: 11/23/2015

Test Procedure

The EUT was connected as shown per KDB 935210 D03 v03. The EUT was verified to shut down in the presence of an oscillation.

The total attenuation from output to input was set +5 dB higher than the gain for the band being tested.

For EUT's that do not shutdown, the peak oscillation was measured and the variable attenuator was reduced in 1 dB increments until the booster shuts off.

The frequency and amplitude of the lowest level within the span and the frequency and amplitude of the oscillation were recorded as required.

The frequency and amplitude of the highest oscillation and the lowest level in the valley next to the oscillation was recorded for each 1 dB step as required per the KDB.

For oscillations that exceeded the 12 dB limit, the time required for the booster to mitigate the oscillation to less than 12 dB was recorded.

If the booster mitigated the oscillation within the 300 second time limit, the time required to mitigate the oscillation was recorded along with the final level of the oscillation after mitigation.

Note: In all cases the booster mitigated the oscillation to less than 12 dB before the 300 second limit.

Test Setup

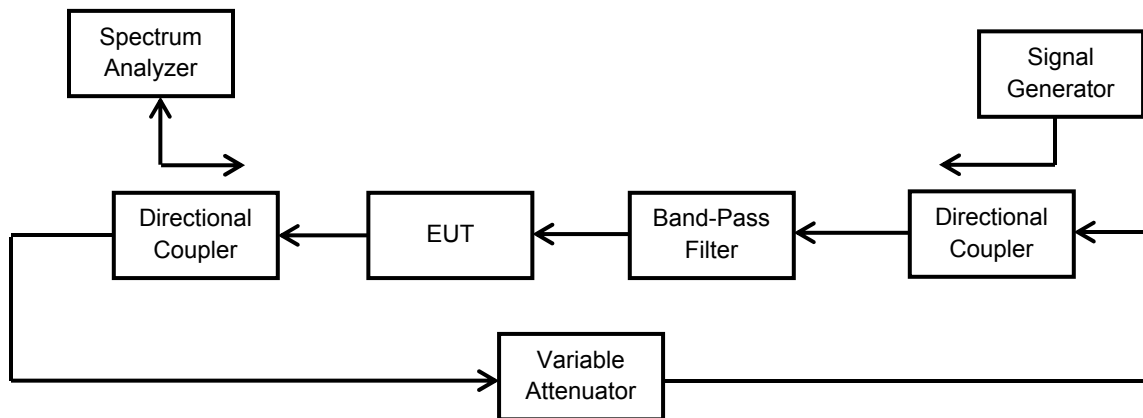

Uplink Oscillation Mitigation Test Data

Oscillation Mitigation - Uplink									
Band	698 – 716 MHz								
Test Signal Type	CDMA								
Variable Attenuator Setting	Oscillations		Lowest Output Power Level		Margin	Limit	Time to Mitigate Oscillation	Mitigation Time Limit	Pass / Fail
	Freq.	Level	Freq.	Level					
dB	MHz	dBm	MHz	dBm	dB	dB	sec	sec	
+5	702.63	-60	700.5	-67.7	7.7	<12	Not required	< 300	Pass
+4	702.63	-59.6	700.5	-68.4	8.8	<12	Not required	< 300	Pass
+3	702.63	-59.8	700.5	-68.1	8.3	<12	Not required	< 300	Pass
2	702.63	-57.5	700.5	-68.3	10.8	<12	Not required	< 300	Pass
+1	702.63	-61.2	700.5	-69.6	8.4	<12	<20	< 300	Pass
+0	702.63	-60	700.5	-70	10	<12	Not required	< 300	Pass
-1	702.63	-58.6	700.5	-69.6	11	<12	Not required	< 300	Pass
-2	702.63	-62.8	700.5	-72	9.2	<12	Not required	< 300	Pass
-3	702.63	-61.4	700.5	-72.1	10.7	<12	<8	< 300	Pass
-4	702.63	-63.9	700.5	-73.7	9.8	<12	<21	< 300	Pass
-5	702.63	-62.9	700.5	-73.4	10.5	<12	Not required	< 300	Pass

Oscillation Mitigation - Uplink									
Band	776 – 787 MHz								
Test Signal Type	CDMA								
Variable Attenuator Setting	Oscillations		Lowest Output Power Level		Margin	Limit	Time to Mitigate Oscillation	Mitigation Time Limit	Pass / Fail
	Freq.	Level	Freq.	Level					
dB	MHz	dBm	MHz	dBm	dB	dB	sec	sec	
+5	784	-60.5	782.3	-67.4	6.9	<12	Not required	< 300	Pass
+4	784	-60.1	782.3	-67.7	7.6	<12	Not required	< 300	Pass
+3	784	-58.6	782.3	-68.5	9.9	<12	Not required	< 300	Pass
2	784	-57.3	782.3	-68.6	11.3	<12	Not required	< 300	Pass
+1	784	-60.8	782.3	-70.1	9.3	<12	<29	< 300	Pass
+0	784	-59.2	782.3	-70.1	10.9	<12	Not required	< 300	Pass
-1	784	-62.7	782.3	-71.6	8.9	<12	<45	< 300	Pass
-2	784	-61.7	782.3	-71.9	10.2	<12	Not required	< 300	Pass
-3	784	-64.8	782.3	-73.1	8.3	<12	<30	< 300	Pass
-4	784	-64	782.3	-73.3	9.3	<12	Not required	< 300	Pass
-5	784	-66.8	782.3	-74.8	8	<12	<23	< 300	Pass

Oscillation Mitigation - Uplink									
Band	824 - 849 MHz								
Test Signal Type	CDMA								
Variable Attenuator Setting	Oscillations		Lowest Output Power Level		Margin	Limit	Time to Mitigate Oscillation	Mitigation Time Limit	Pass / Fail
	Freq.	Level	Freq.	Level					
dB	MHz	dBm	MHz	dBm	dB	dB	sec	sec	
+5	836.1	-58.6	838.1	-67.5	8.9	<12	Not required	< 300	Pass
+4	836.1	-58.3	838.1	-67.8	9.5	<12	Not required	< 300	Pass
+3	836.1	-57.2	838.1	-68.3	11.1	<12	Not required	< 300	Pass
2	836.1	-59.6	838.1	-69.4	9.8	<12	<30	< 300	Pass
+1	836.1	-58.4	838.1	-70	11.6	<12	Not required	< 300	Pass
+0	836.1	-62.3	838.1	-71.3	9	<12	<21	< 300	Pass
-1	836.1	-65.3	838.1	-72.5	7.2	<12	<25	< 300	Pass
-2	836.1	-64.1	838.1	-72.8	8.7	<12	Not required	< 300	Pass
-3	836.1	-65.6	838.1	-74.2	8.6	<12	Not required	< 300	Pass
-4	836.1	-65.6	838.1	-74.4	8.8	<12	Not required	< 300	Pass
-5	836.1	-67.5	838.1	-74.9	7.4	<12	<35	< 300	Pass

Oscillation Mitigation - Uplink									
Band	1710 - 1755 MHz								
Test Signal Type	CDMA								
Variable Attenuator Setting	Oscillations		Lowest Output Power Level		Margin	Limit	Time to Mitigate Oscillation	Mitigation Time Limit	Pass / Fail
	Freq.	Level	Freq.	Level					
dB	MHz	dBm	MHz	dBm	dB	dB	sec	sec	
+5	1730.25	-56.6	1736.65	-66.4	9.8	<12	Not required	< 300	Pass
+4	1730.25	-55	1736.65	-66.4	11.4	<12	Not required	< 300	Pass
+3	1730.25	-56.1	1736.65	-62.7	6.6	<12	<40	< 300	Pass
2	1730.25	-60.1	1736.65	-64.6	4.5	<12	Not required	< 300	Pass
+1	1730.25	-60.2	1736.65	-64.1	3.9	<12	Not required	< 300	Pass
+0	1730.25	-58.9	1736.65	-65.2	6.3	<12	Not required	< 300	Pass
-1	1730.25	-57.5	1736.65	-64.7	7.2	<12	Not required	< 300	Pass
-2	1730.25	-63.4	1736.65	-65.7	2.3	<12	Not required	< 300	Pass
-3	1730.25	-64.3	1736.65	-65.3	1	<12	Not required	< 300	Pass
-4	1730.25	-64.2	1736.65	-65.1	0.9	<12	Not required	< 300	Pass
-5	1730.25	-63.4	1736.65	-65.3	1.9	<12	Not required	< 300	Pass

Oscillation Mitigation - Uplink									
Band	1850 - 1915 MHz								
Test Signal Type	CDMA								
Variable Attenuator Setting	Oscillations		Lowest Output Power Level		Margin	Limit	Time to Mitigate Oscillation	Mitigation Time Limit	Pass / Fail
	Freq.	Level	Freq.	Level					
dB	MHz	dBm	MHz	dBm	dB	dB	sec	sec	
+5	1876.08	-57.5	1880.78	-64.8	7.3	<12	Not required	< 300	Pass
+4	1876.08	-56.6	1880.78	-64.8	8.2	<12	Not required	< 300	Pass
+3	1876.08	-56.5	1880.78	-64.9	8.4	<12	Not required	< 300	Pass
2	1876.08	-55.7	1880.78	-65.1	9.4	<12	Not required	< 300	Pass
+1	1876.08	-60.1	1880.78	-67.6	7.5	<12	<15	< 300	Pass
+0	1876.08	-59.9	1880.78	-67.5	7.6	<12	Not required	< 300	Pass
-1	1876.08	-58.8	1880.78	-68.2	9.4	<12	Not required	< 300	Pass
-2	1876.08	-62.7	1880.78	-69	6.3	<12	Not required	< 300	Pass
-3	1876.08	-61	1880.78	-68.9	7.9	<12	Not required	< 300	Pass
-4	1876.08	-63.8	1880.78	-69.3	5.5	<12	Not required	< 300	Pass
-5	1876.08	-64.2	1880.78	-70.2	6	<12	Not required	< 300	Pass

Downlink Oscillation Mitigation Test Data

Oscillation Mitigation - Downlink									
Band	728 - 746 MHz								
Test Signal Type	CDMA								
Variable Attenuator Setting	Oscillations		Lowest Output Power Level		Margin	Limit	Time to Mitigate Oscillation	Mitigation Time Limit	Pass / Fail
	Freq.	Level	Freq.	Level					
dB	MHz	dBm	MHz	dBm	dB	dB	sec	sec	
+5	738	-64.5	740.7	-70.5	6	<12	Not required	< 300	Pass
+4	738	-64.6	740.7	-70.4	5.8	<12	Not required	< 300	Pass
+3	738	-63.1	740.7	-70.6	7.5	<12	Not required	< 300	Pass
2	738	-63.3	740.7	-70.5	7.2	<12	Not required	< 300	Pass
+1	738	-62.1	740.7	-71.1	9	<12	Not required	< 300	Pass
+0	738	-65.6	740.7	-72.6	7	<12	Not required	< 300	Pass
-1	738	-67.6	740.7	-73.9	6.3	<12	Not required	< 300	Pass
-2	738	-66.9	740.7	-74.4	7.5	<12	Not required	< 300	Pass
-3	738	-66.1	740.7	-74.3	8.2	<12	Not required	< 300	Pass
-4	738	-67.7	740.7	-75.4	7.7	<12	Not required	< 300	Pass
-5	738	-67.5	740.7	-75.6	8.1	<12	Not required	< 300	Pass

Oscillation Mitigation - Downlink									
Band	746 - 757 MHz								
Test Signal Type	CDMA								
Variable Attenuator Setting	Oscillations		Lowest Output Power Level		Margin	Limit	Time to Mitigate Oscillation	Mitigation Time Limit	Pass / Fail
	Freq.	Level	Freq.	Level					
dB	MHz	dBm	MHz	dBm	dB	dB	sec	sec	
+5	748.96	-64.7	751.44	-68	3.3	<12	Not required	< 300	Pass
+4	748.96	-64.5	751.44	-69	4.5	<12	Not required	< 300	Pass
+3	748.96	-64.7	751.44	-69.2	4.5	<12	Not required	< 300	Pass
2	748.96	-63.9	751.44	-68.9	5	<12	Not required	< 300	Pass
+1	748.96	-63.3	751.44	-68.6	5.3	<12	Not required	< 300	Pass
+0	748.96	-62.9	751.44	-69	6.1	<12	Not required	< 300	Pass
-1	748.96	-62.3	751.44	-68.8	6.5	<12	Not required	< 300	Pass
-2	748.96	-61.8	751.44	-69	7.2	<12	Not required	< 300	Pass
-3	748.96	-66.5	751.44	-70.2	3.7	<12	Not required	< 300	Pass
-4	748.96	-66	751.44	-70.1	4.1	<12	Not required	< 300	Pass
-5	748.96	-67.8	751.44	-70	2.2	<12	Not required	< 300	Pass

Oscillation Mitigation - Downlink									
Band	869 - 894 MHz								
Test Signal Type	CDMA								
Variable Attenuator Setting	Oscillations		Lowest Output Power Level		Margin	Limit	Time to Mitigate Oscillation	Mitigation Time Limit	Pass / Fail
	Freq.	Level	Freq.	Level					
dB	MHz	dBm	MHz	dBm	dB	dB	sec	sec	
+5	877.79	-60.7	879.64	-64.8	4.1	<12	Not required	< 300	Pass
+4	877.79	-60.3	879.64	-65.9	5.6	<12	Not required	< 300	Pass
+3	877.79	-59.6	879.64	-65.8	6.2	<12	Not required	< 300	Pass
2	877.79	-58.6	879.64	-65.8	7.2	<12	Not required	< 300	Pass
+1	877.79	-58.2	879.64	-66.5	8.3	<12	Not required	< 300	Pass
+0	877.79	-57.3	879.64	-66.5	9.2	<12	Not required	< 300	Pass
-1	877.79	-55.5	879.64	-66.5	11	<12	Not required	< 300	Pass
-2	877.79	-59.4	879.64	-67.6	8.2	<12	<25	< 300	Pass
-3	877.79	-57.6	879.64	-67.8	10.2	<12	Not required	< 300	Pass
-4	877.79	-60.8	879.64	-68.8	8	<12	<20	< 300	Pass
-5	877.79	-59.7	879.64	-64.3	4.6	<12	Not required	< 300	Pass

Oscillation Mitigation - Downlink									
Band	1930 - 1995 MHz								
Test Signal Type	CDMA								
Variable Attenuator Setting	Oscillations		Lowest Output Power Level		Margin	Limit	Time to Mitigate Oscillation	Mitigation Time Limit	Pass / Fail
	Freq.	Level	Freq.	Level					
dB	MHz	dBm	MHz	dBm	dB	dB	sec	sec	
+5	1977.4	-50.1	1973.6	-60.1	10	<12	Not required	< 300	Pass
+4	1977.4	-49.4	1973.6	-59.7	10.3	<12	Not required	< 300	Pass
+3	1977.4	-48.5	1973.6	-60.3	11.8	<12	Not required	< 300	Pass
2	1977.4	-52	1973.6	-61.9	9.9	<12	<20	< 300	Pass
+1	1977.4	-50.6	1973.6	-62.2	11.6	<12	Not required	< 300	Pass
+0	1977.4	-53.5	1973.6	-63.4	9.9	<12	Not required	< 300	Pass
-1	1977.4	-56.4	1973.6	-64.7	8.3	<12	<20	< 300	Pass
-2	1977.4	-56	1973.6	-65.4	9.4	<12	Not required	< 300	Pass
-3	1977.4	-58.6	1973.6	-67.2	8.6	<12	<20	< 300	Pass
-4	1977.4	-58.3	1973.6	-67	8.7	<12	Not required	< 300	Pass
-5	1977.4	-56.6	1973.6	-66.8	10.2	<12	Not required	< 300	Pass

Oscillation Mitigation - Uplink									
Band	2110 - 2155 MHz								
Test Signal Type	CDMA								
Variable Attenuator Setting	Oscillations		Lowest Output Power Level		Margin	Limit	Time to Mitigate Oscillation	Mitigation Time Limit	Pass / Fail
	Freq.	Level	Freq.	Level					
dB	MHz	dBm	MHz	dBm	dB	dB	sec	sec	
+5	2145.6	-52.5	2140.5	-60.7	8.2	<12	Not required	< 300	Pass
+4	2145.6	-51.5	2140.5	-60.8	9.3	<12	Not required	< 300	Pass
+3	2145.6	-50.5	2140.5	-61.4	10.9	<12	Not required	< 300	Pass
2	2145.6	-53.9	2140.5	-63.5	9.6	<12	<25	< 300	Pass
+1	2145.6	-52.8	2140.5	-63.1	10.3	<12	Not required	< 300	Pass
+0	2145.6	-55.8	2140.5	-64.5	8.7	<12	<50	< 300	Pass
-1	2145.6	-54.3	2140.5	-64.9	10.6	<12	Not required	< 300	Pass
-2	2145.6	-57.6	2140.5	-66.3	8.7	<12	<20	< 300	Pass
-3	2145.6	-56.6	2140.5	-66	9.4	<12	Not required	< 300	Pass
-4	2145.6	-61.9	2140.5	-68.8	6.9	<12	<20	< 300	Pass
-5	2145.6	-57.8	2140.5	-67.8	10	<12	Not required	< 300	Pass

Radiated Spurious

Engineer: Greg Corbin

Test Date: 11/123/2015

Test Procedure

The EUT was tested in a semi-anechoic chamber with the turntable set 3m from the receiving antenna. A spectrum analyzer was used to verify that the EUT met the requirements for Radiated Emissions. The EUT was tested by rotating it 360 degrees with the antenna in both the vertical and horizontal orientation while raised from 1 to 4 meters to ensure that the signal levels were maximized. All cable and antenna correction factors were input into the spectrum analyzer ensuring an accurate measurement in ERP/EIRP with the resultant power in dBm. A signal generator was used to provide a CW signal centered in each operational uplink and downlink band. The EUT output was terminated into a 50 Ohm non-radiating load.

The following formula was used for calculating the limits:

Radiated Spurious Emissions Limit = $P1 - (43 + 10\text{Log}(P2)) = -13\text{dBm}$

P1 = power in dBm

P2 = power in Watts

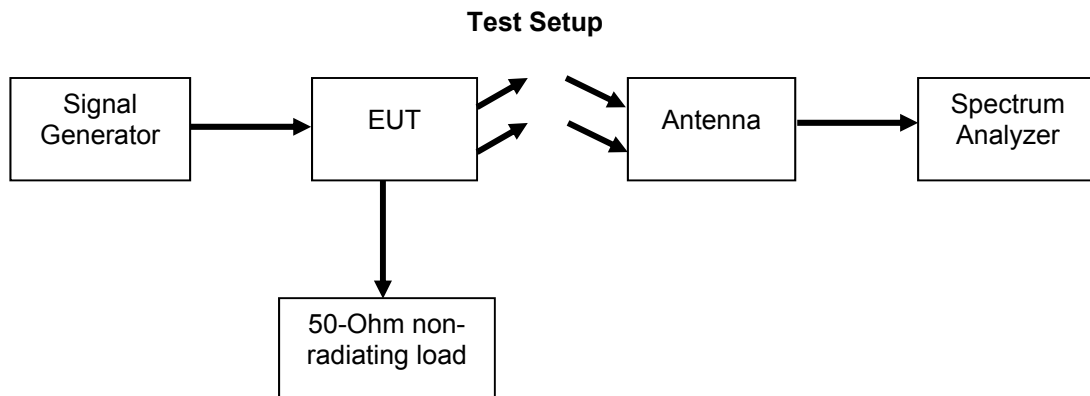

Uplink Test Results

698 - 716 MHz Band
30 – 1000 MHz

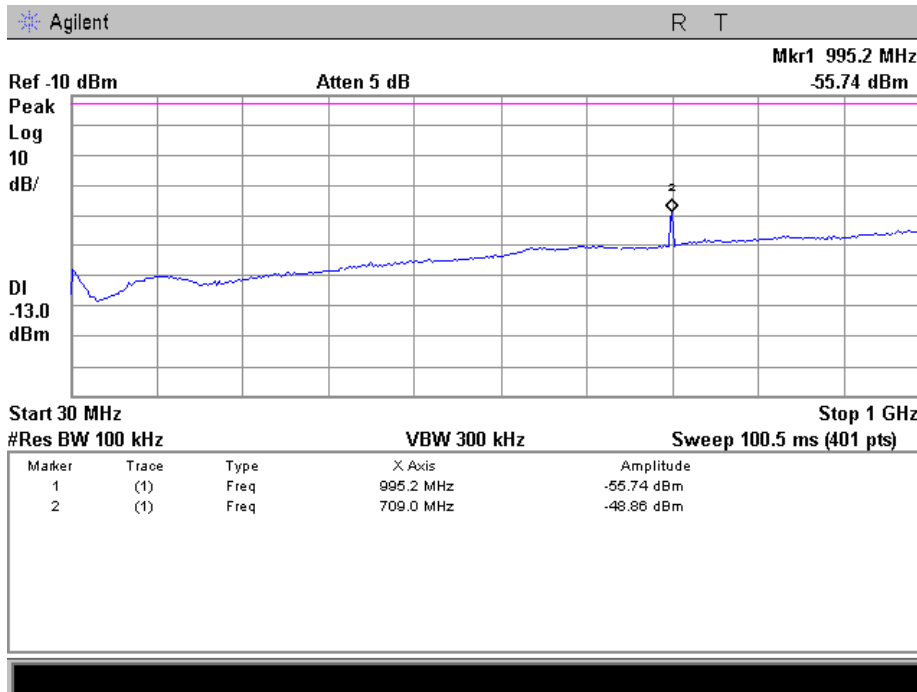

1 – 18 GHz

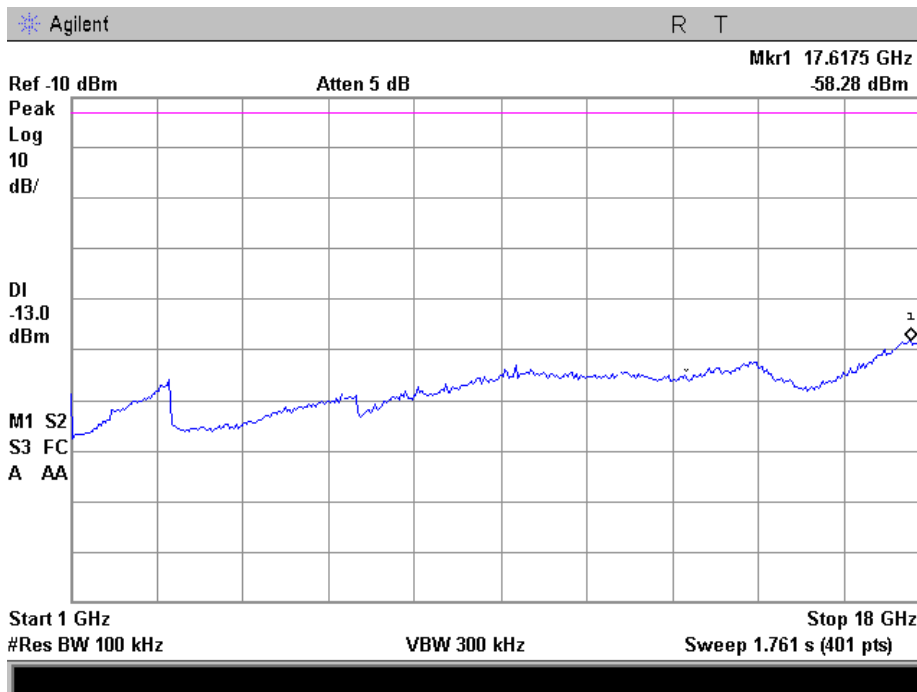

776 - 787 MHz Band
30 - 1000 MHz

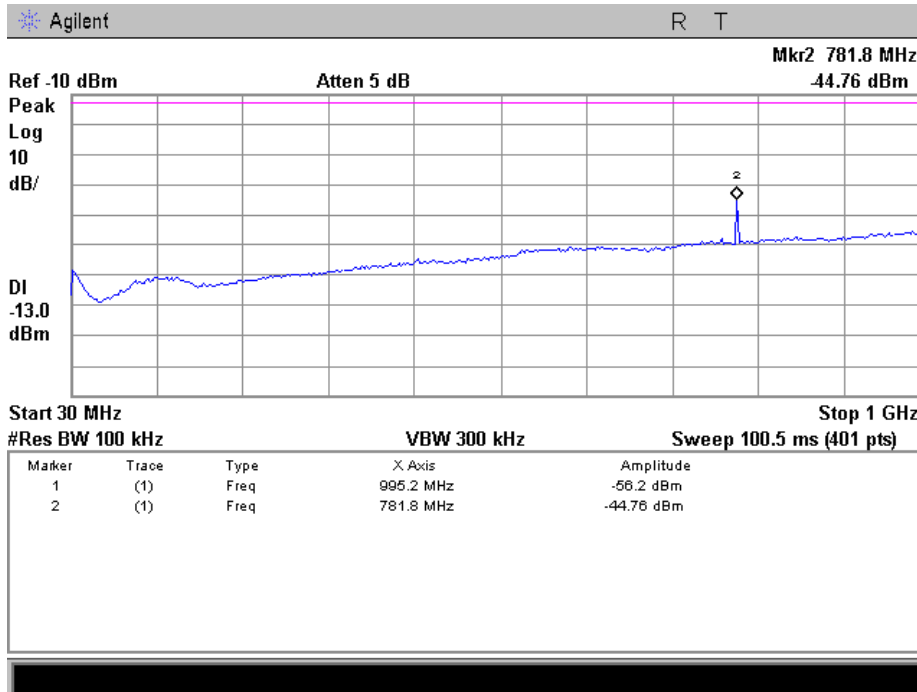

1 - 18 GHz

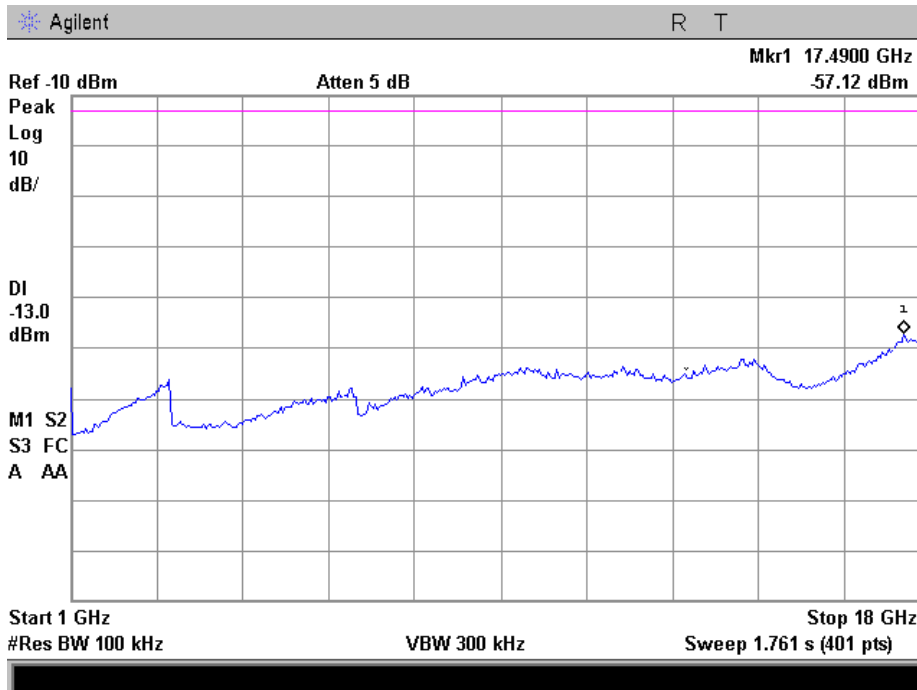

824 - 849 MHz Band
30 - 1000 MHz

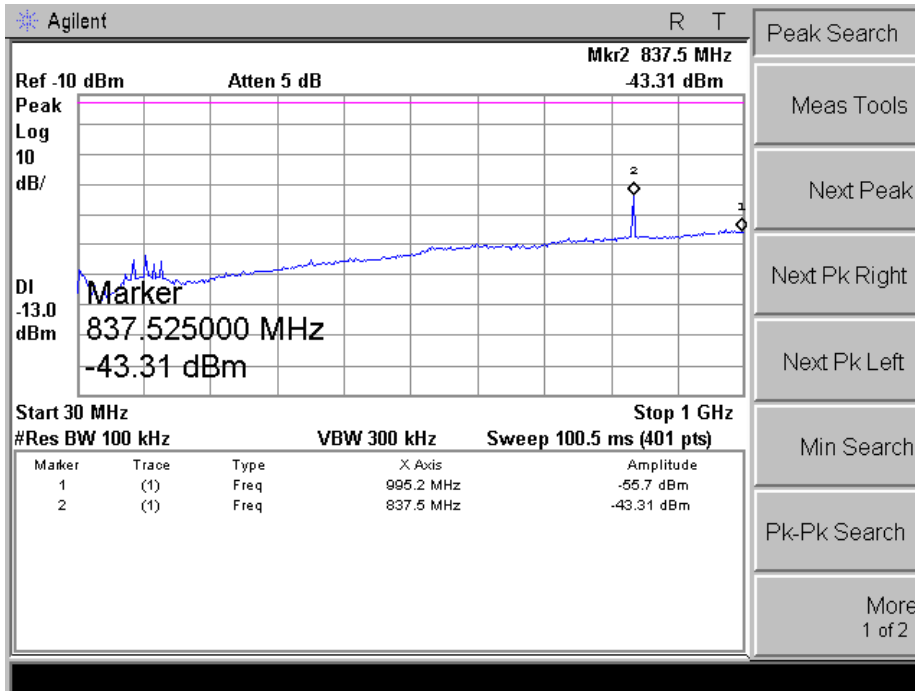

1 - 18 GHz

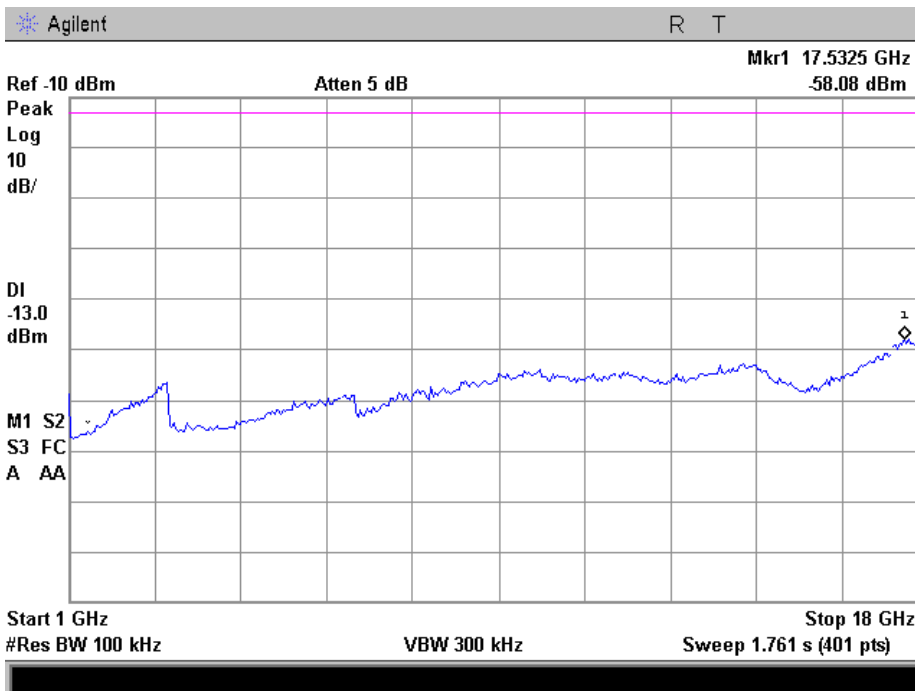

1710 - 1755 MHz Band
30 - 1000 MHz

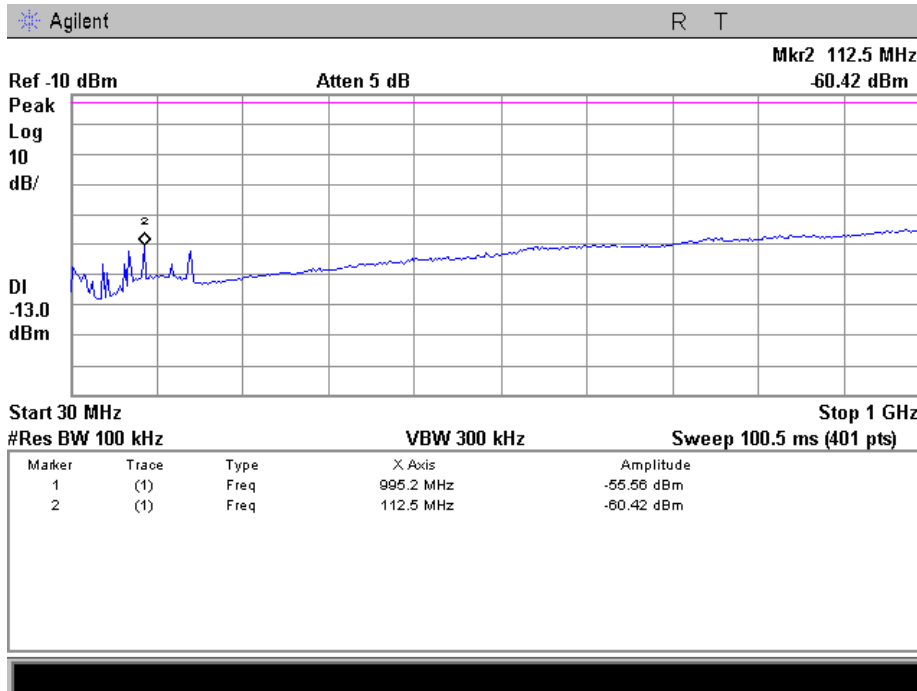

1 - 18 GHz

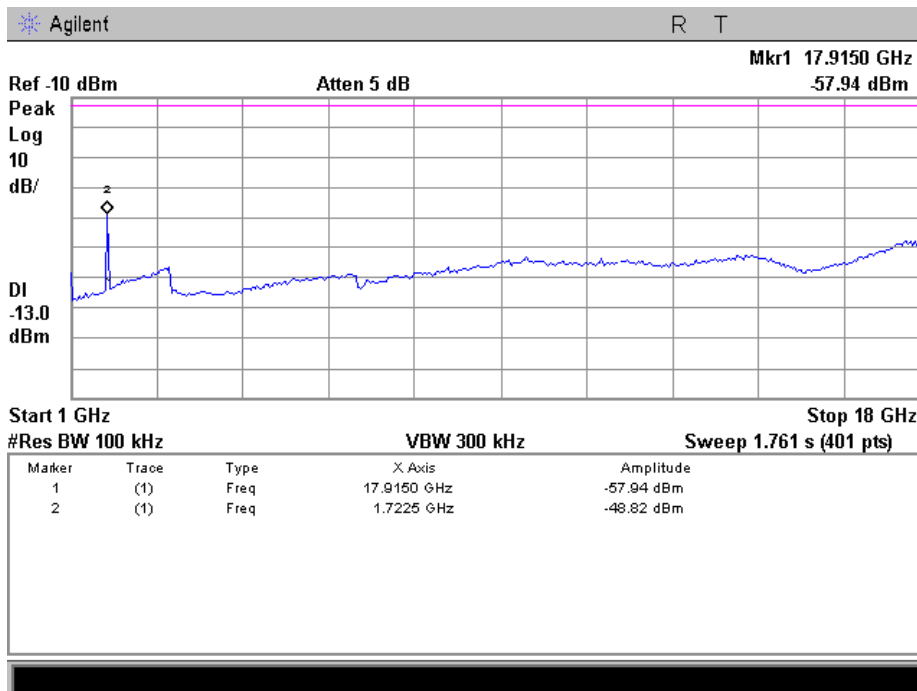

1850 - 1915 MHz Band
30 - 1000 MHz

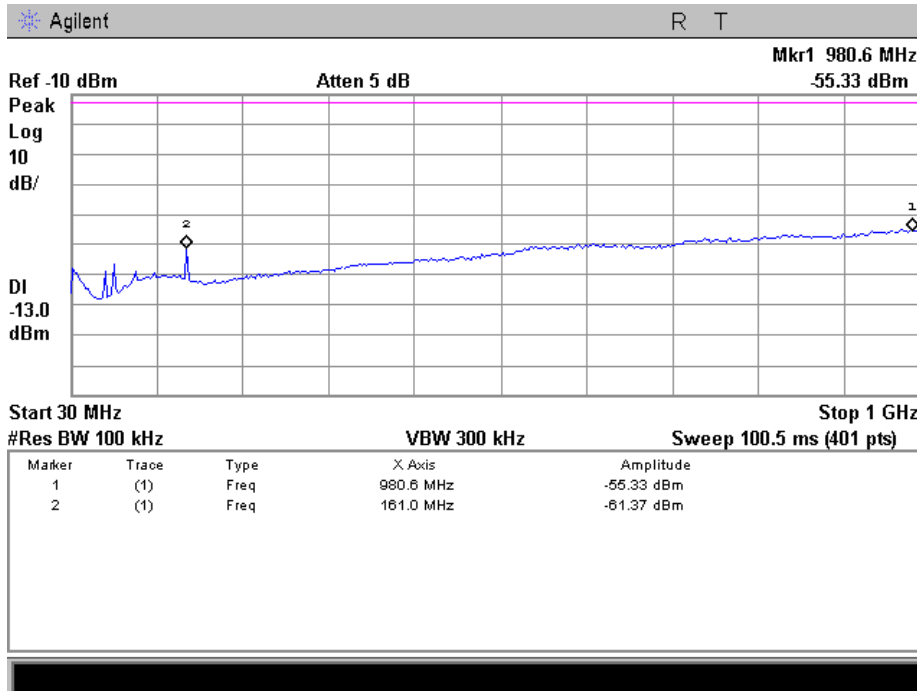

1 - 18 GHz

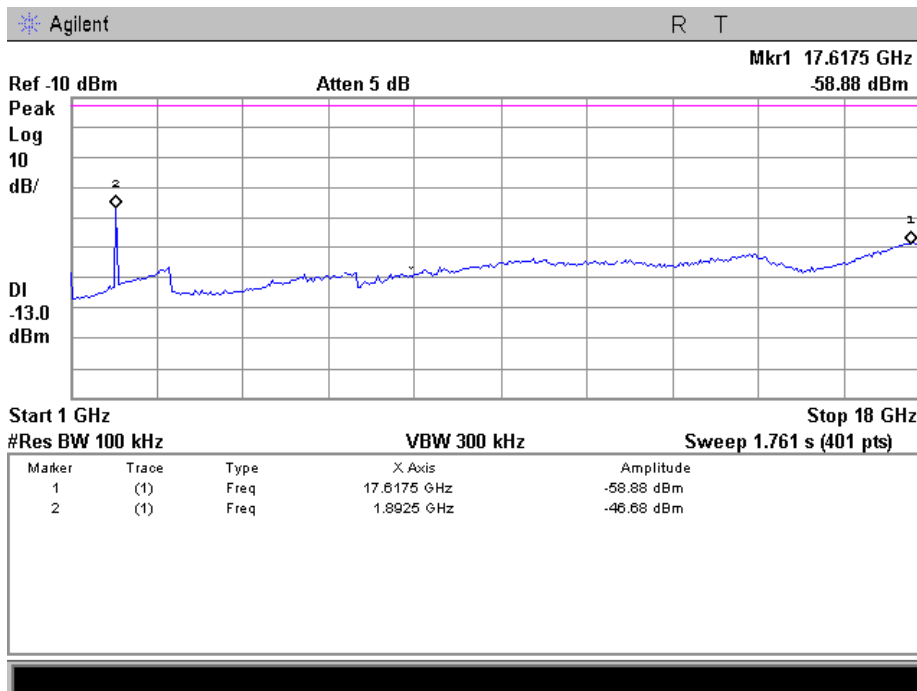

Downlink Test Results

728 - 746 MHz Band
30 - 1000 MHz

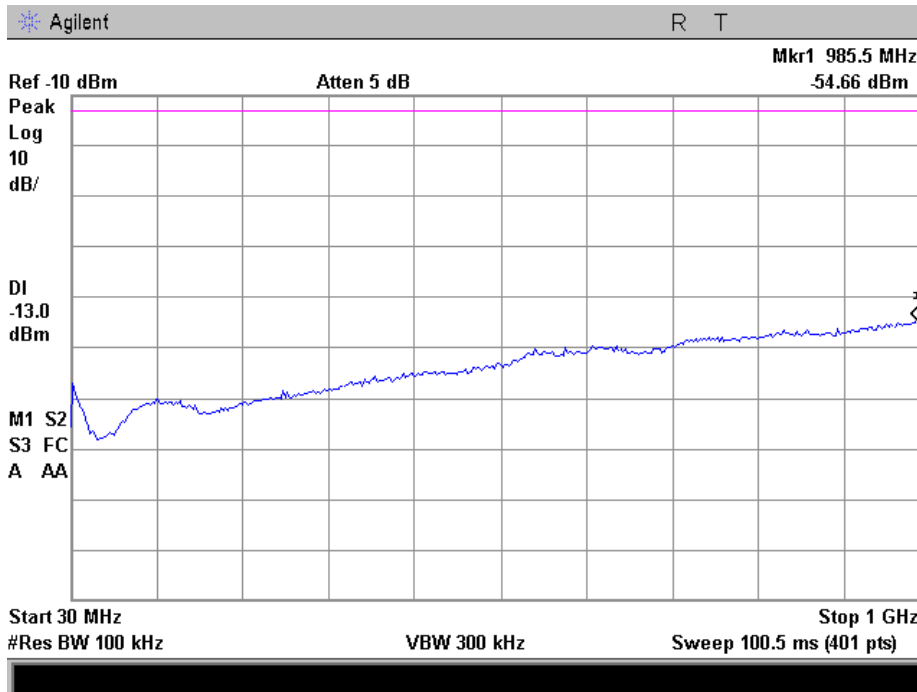

1 - 18 GHz

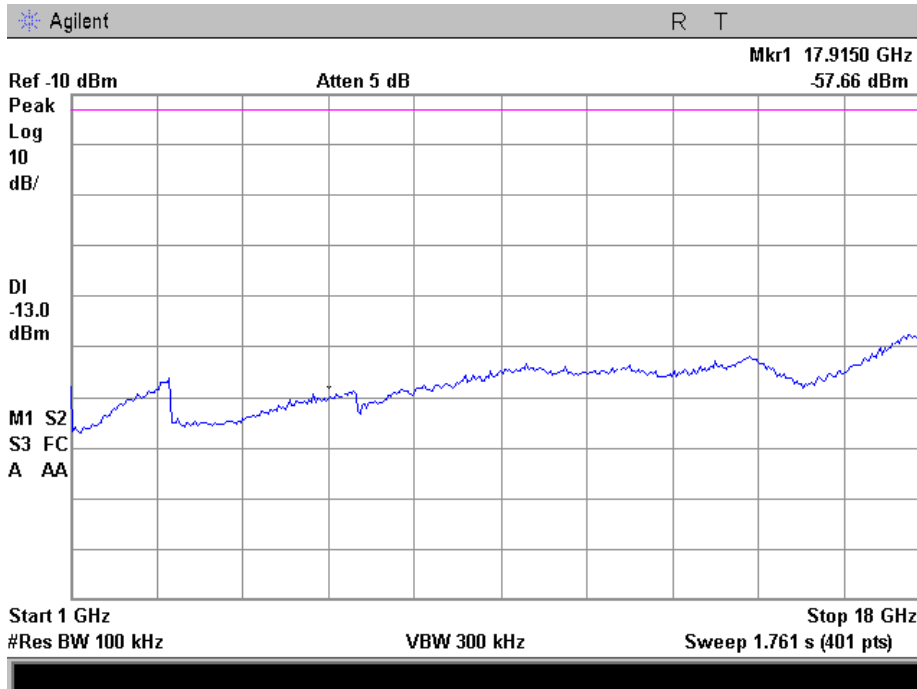

746 - 757 MHz Band
30 - 1000 MHz

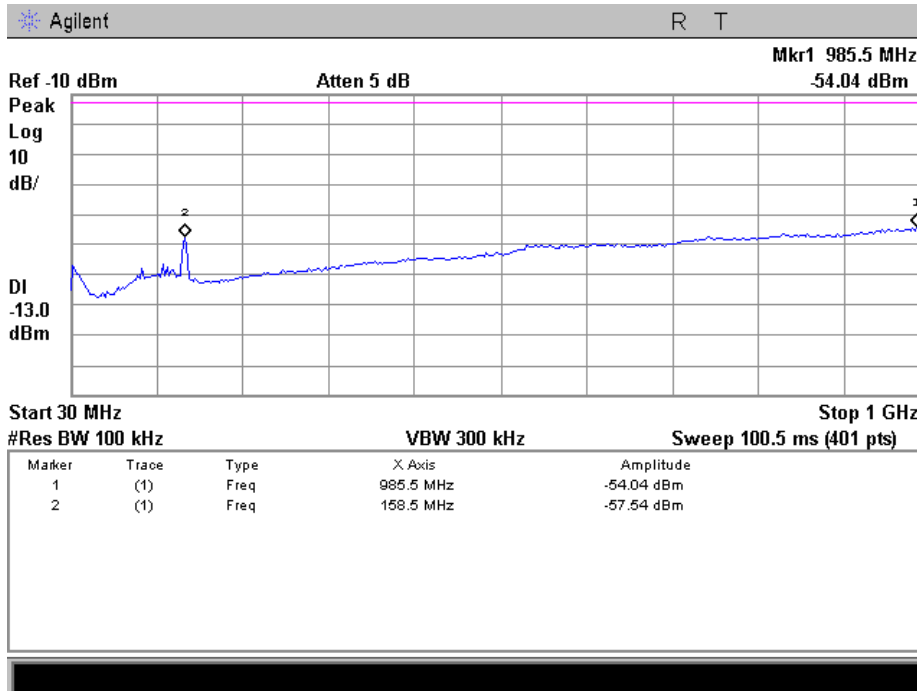

1 - 18 GHz

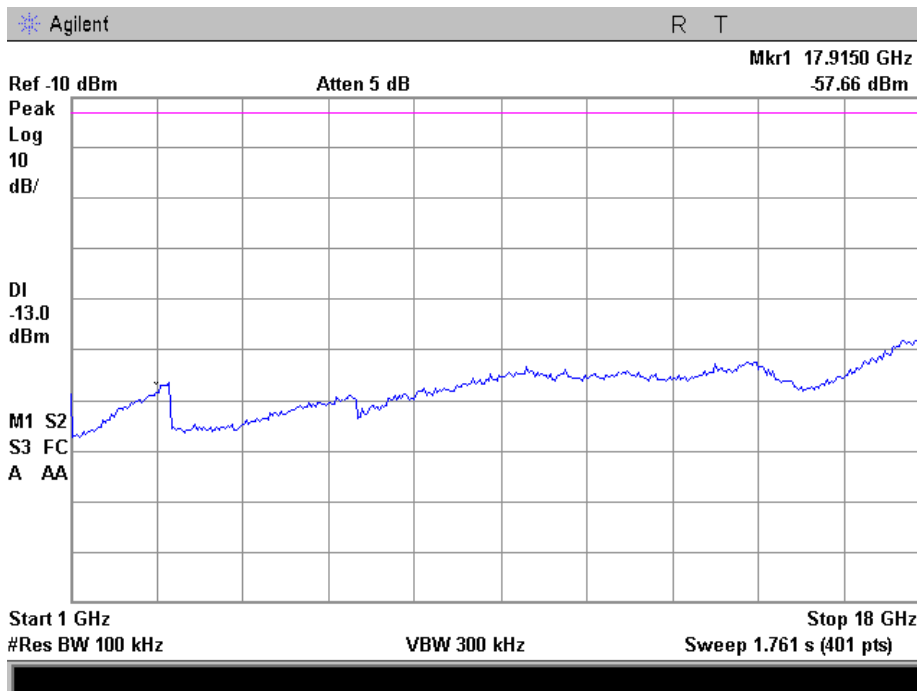

869 - 894 MHz Band
30 - 1000 MHz

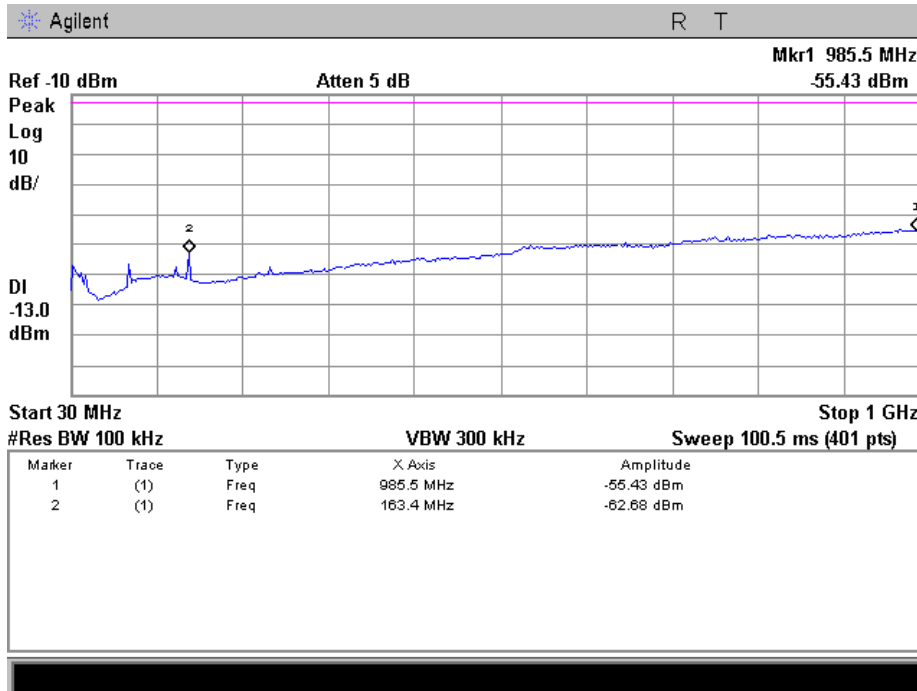

1 - 18 GHz

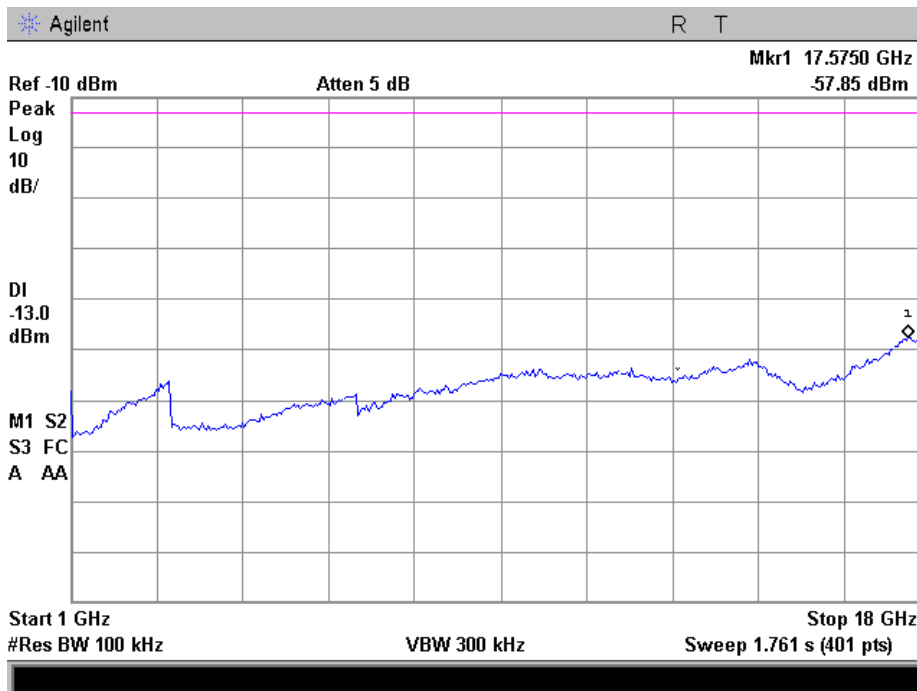

1930 - 1995 MHz Band
30 - 1000 MHz

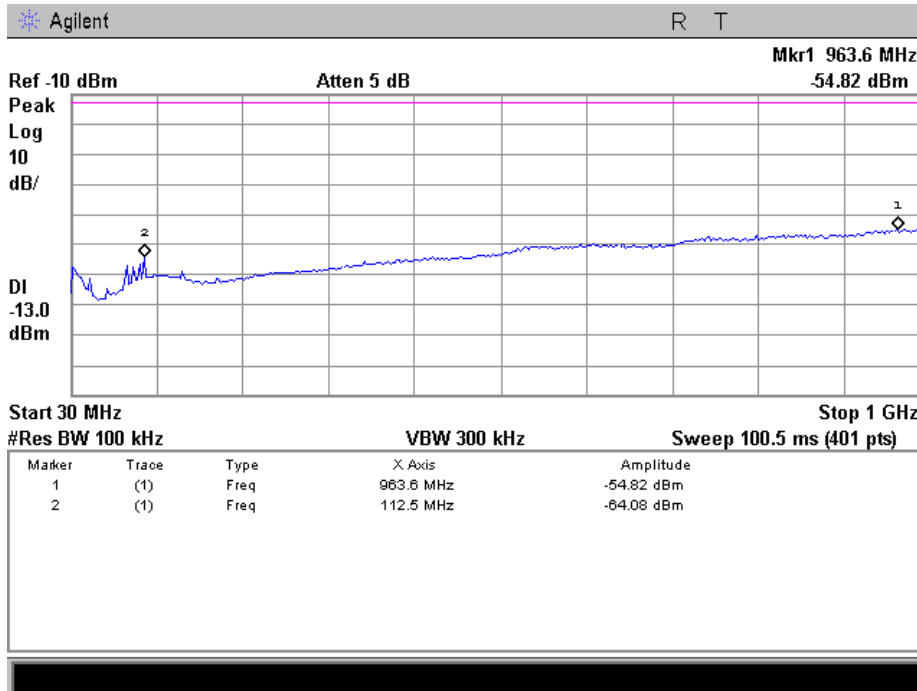

1 - 18 GHz

