



Compliance Testing, LLC

Previously Flom Test Lab

EMI, EMC, RF Testing Experts Since 1963

toll-free: (866) 311-3268

fax: (480) 926-3598

<http://www.ComplianceTesting.com>

info@ComplianceTesting.com

Test Report

Prepared for: Wilson Electronics, LLC

Model: 460030

Description: Quint Band Signal Booster

Serial Number: N/A

FCC ID: PWO460030IL

To

FCC Part 20

Date of Issue: June 29, 2017

On the behalf of the applicant:

Wilson Electronics, LLC
3301 E Deseret Drive
St. George, UT 84790

To the attention of:

Erin Elder, Senior IP and Compliance Engineer
Ph: (435)673-5021
Email: eelder@wilsonelectronics.com

Prepared By
Compliance Testing, LLC
1724 S. Nevada Way
Mesa, AZ 85204
(480) 926-3100 phone / (480) 926-3598 fax
www.compliancetesting.com
Project No: p1710013

Greg Corbin
Project Test Engineer

This report may not be reproduced, except in full, without written permission from Compliance Testing.
All results contained herein relate only to the sample tested.

Test Report Revision History

Revision	Date	Revised By	Reason for Revision
1.0	June 19, 2017	Alex Macon	Original Document
2.0	June 29, 2017	Alex Macon	Removed typo from Annex B page 12

Table of Contents

<u>Description</u>	<u>Page</u>
Standard Test Conditions and Engineering Practices	5
Manufacturer's Description of the EUT	6
Test Result Summary	7
Authorized Frequency Band	8
Maximum Power and Gain	9
Intermodulation	18
Out-of-Band Emissions	21
Conducted Spurious Emissions	31
Noise Limits	40
Uplink Inactivity	47
Variable Gain	49
Occupied Bandwidth	54
Anti-Oscillation	55
Oscillation Mitigation	62
Radiated Spurious	77
Test Equipment Utilized	78

ILAC / A2LA

Compliance Testing, LLC, has been accredited in accordance with the recognized International Standard ISO/IEC 17025:2005. This accreditation demonstrates technical competence for a defined scope and the operation of a laboratory quality management system (refer to the joint ISO-ILAC-IAF Communiqué dated January 2009).

The tests results contained within this test report all fall within our scope of accreditation, unless noted below.

Please refer to <http://www.compliancetesting.com/labscope.html> for current scope of accreditation.

Testing Certificate Number: **2152.01**



FCC Site Reg. #349717

IC Site Reg. #2044A-2

Non-accredited tests contained in this report:

N/A

Test and Measurement Data

Sub-part
 2.1033(c)(14):

All tests and measurement data shown were performed in accordance with FCC Rules and Regulations, Part 2, Subpart J and the following individual Parts: 20.21 in conjunction with latest version of KDB 935210.

Standard Test Conditions and Engineering Practices

Except as noted herein, the following conditions and procedures were observed during the testing:

In accordance with ANSI/C63.4-2014, and unless otherwise indicated in the specific measurement results, the ambient temperature of the actual EUT was maintained within the range of 10° to 40°C (50° to 104°F), unless the particular equipment requirements specified testing over a different temperature range. Also, unless otherwise indicated, the humidity levels were in the range of 10% to 90% relative humidity.

Environmental Conditions		
Temp (°C)	Humidity (%)	Pressure (mbar)
15.6 – 21.9	34.7 – 51.2	953.8 – 987.0

Measurement results, unless otherwise noted, are worst-case measurements.

EUT Description

Model: 460030

Description: Quint Band Signal Booster

Firmware: A460030A

Software: 460030A

Serial Number: N/A

Additional Information:

The EUT is an **In-Building** bi-directional amplifier for the boosting of cellular phone signals and data communication devices. Refer to page 6 for additional information on the description of the EUT.

The following frequency bands and emission types are utilized.

Frequency Band (MHz)					
Uplink	698 - 716	776 – 787	824 - 849	1850 – 1915	1710 – 1755
Downlink	728 - 746	746 – 757	869 - 894	1930 - 1995	2110 - 2155
Modulation Type	GSM, CDMA, EDGE, HSPA, EVDO, LTE		GSM, CDMA, EDGE, HSPA, EVDO, LTE		CDMA, HSPA, LTE, EDGE, EVDO

Emission Designators					
CDMA	HSPA	LTE	EVDO	EDGE	GSM
F9W	F9W	G7D	F9W	G7W	GXW

The modulation types and emission designators listed in the tables represent the modulations that the cell phone providers use for each frequency band. GSM, CDMA, and WCDMA represent all the modulation types (phase and amplitude or a combination thereof) utilized within the industry. EDGE, HSPA, LTE etc. are all protocols or multiplexing techniques using the base modulations.

Manufacturer's Description of the EUT

Two-Enclosure Booster System

The two-enclosure booster system consists of 3 parts (as identified in the diagram below from KDB 935210 D02v3r2) the server enclosure(C), the donor enclosure (B), and the RF cable link (5,6). The donor and server communicate over the RF cable. The booster is not enabled until communication is established between the donor and server unit, and the amount of coax loss between them is determined. As shown in the diagram below, if communication is ever lost on cable (5,6) the booster is immediately turned off until communication is reestablished and the amount of loss between the units on cable (5,6) can be determined. At no time can either unit be used as a standalone product or in conjunction with any other booster due to the fact that both units must communicate with each other in order to enable the two-enclosure booster system. The purpose of the inline booster system is to remove the losses associated with long indoor cable runs to the server antenna. The booster system maintains all requirements in Part 20.21 from the conducted server port to the conducted donor port and is capable of removing up to 20dB of loss on cable (5,6) between the units. A minimum loss of 3dB is required in order for the system to operate, anything less causes a shutdown of the system.

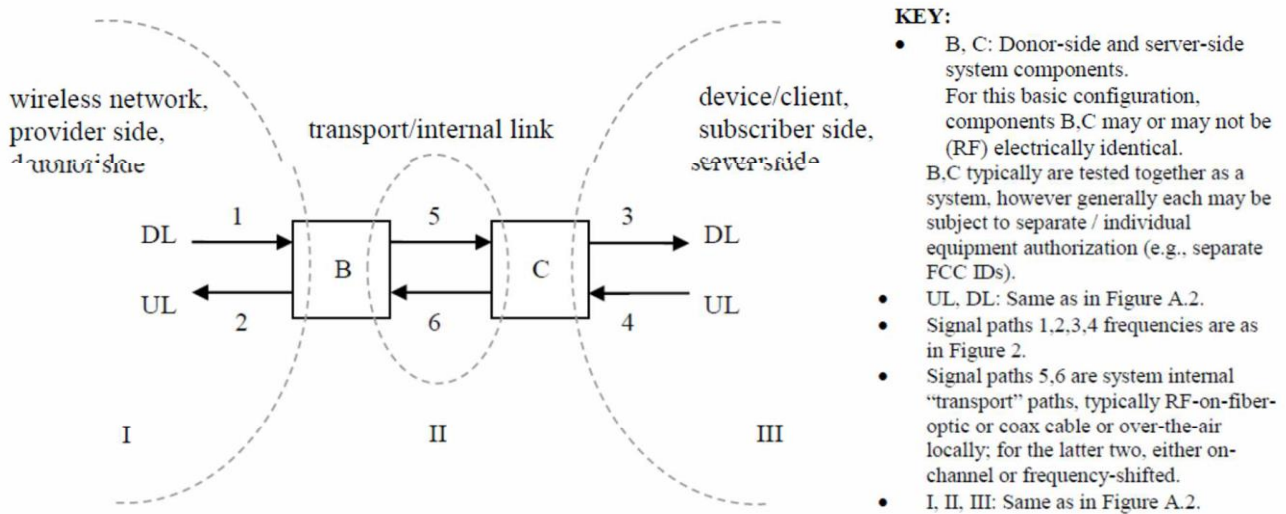

Figure A.3 – Simplified schematic of two-enclosure booster system, and signal path and coverage/operations regions geometries

EUT Operation during Tests

The EUT was in a normal operating condition with all external attenuation set to 0 dB.

This booster hardware is in 2 enclosures with various cable lengths between the 2 enclosures. The server port is attached to an enclosure referred to the manufacturer as the inline unit and the donor port is attached to an enclosure referred to by the manufacturer as the main unit.

With shorter cable lengths the unit does not operate.

This was demonstrated by inserting a 60 ft. cable between the mainline unit and the inline unit.

With the 60 ft. cable length inserted between the main and inline units and the EUT would not pass a signal in any band. The LCD display on the mainline unit read "Failed Cal".

This was repeated with a 70 ft. length, an 80 ft. length and a 90 foot length with identical results.

One of the inline unit's LEDs, which in normally green with 100 ft. and 300 ft. cable lengths, turned red with a 60 ft to 90 foot. cable lengths.

With a 100 ft. and 300 ft. cable inserted between the main and Inline units the booster operated normally and passed signals in all bands.

Test data for 100 ft., 200 ft. and 300 ft. cable lengths are provided for the following tests:

Authorized Frequency Band, Output Power, Gain, Intermodulation, OOBE, OCC BW, Conducted Spurious, Noise Power, Variable Noise, Variable Gain, Variable Noise Timing, Variable Gain Timing, Oscillation Mitigation and Oscillation Detection.

Test Result Summary

Specification	Test Name	Pass, Fail, N/A	Comments
20.21(e)(3)	Authorized Frequency Band	Pass	
20.21(e)(8)(i)(B) 20.21(e)(8)(i)(C) 20.21(e)(8)(i)(D)	Maximum Power and Gain	Pass	
20.21(e)(8)(i)(F)	Intermodulation	Pass	
20.21(e)(8)(i)(E)	Out-of-Band Emissions	Pass	
2.1051 22.917(a) 24.238((a) 27.53(c) 27.53(f) 27.53(g) 27.53(h)	Conducted Spurious Emissions	Pass	
20.21(e)(8)(i)(A)	Noise Limits	Pass	
20.21(e)(8)(i)(I)	Uplink Inactivity	Pass	
20.21(e)(8)(i)(C)(1) 20.21(e)(8)(i)(H) Choose: 20.21(e)(8)(i)(C)(2)(i) (Fixed)	Variable Gain	Pass	
2.1049	Occupied Bandwidth	Pass	
20.21(e)(8)(ii)(A)	Anti - Oscillation	Pass	
2.1053	Radiated Spurious	Pass	
20.21(e)(8)(i)(B)	Spectrum Block Filtering	N/A	This only applies to devices utilizing spectrum block filtering

Authorized Frequency Band

Engineer: Greg Corbin

Test Date: 6/1/2017

Test Procedure

The EUT was connected to a spectrum analyzer through an attenuator with the losses being input into the spectrum analyzer as a combination of reference level offset and correction factor as needed to ensure accurate readings. A signal generator was utilized to produce a CW input signal tuned to the center channel of the operational band. The RF input level was increased to a point just prior to the AGC being in control of the power. The Signal generator was set to sweep across 2X the operational band of the EUT while the spectrum analyzer was set to MAX HOLD. Two markers were placed at the edges of the operational band and a third marker was placed at the highest point within the band no closer than 2.5 MHz from the band edge.

Test Setup

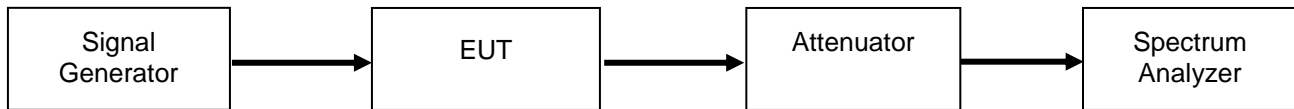

Refer to Annex A for Authorized Frequency Band plots

Maximum Power and Gain

Engineer: Greg Corbin

Test Date: 1/26/2017

Test Procedure

The EUT was connected to a spectrum analyzer through an attenuator with the losses being input into the spectrum analyzer as a combination of reference level offset and correction factor as needed to ensure accurate readings. The spectrum analyzer and signal generator were tuned to the frequency with the highest power level in the band, as determined by the Authorized Frequency Band test. The RF input level was increased to a point just prior to the AGC being in control of the power for both pulsed single time slot GSM modulation and 4.1 MHz AWGN modulation. The maximum power was measured and verified to meet the minimum and maximum levels allowed, with the maximum gain being computed from these values. The uplink and downlink gain under each condition were verified to be within 9 dB of each other.

The input level was incremented in 2 dB steps up to the maximum input level for the EUT. The output power was recorded at the maximum input level. If the EUT shutdown before the maximum input level was reached, the input level was reduced to 1 dB before the EUT shutdown and the input and output levels were recorded.

For Fixed installations the following formula was used for calculating the gain limits.

$$\text{Gain Limit (dB)} = 6.5 \text{ dB} + 20\text{Log}(F_{\text{MHz}})$$

F_{MHz} is the uplink mid-band frequency with the downlink gain limit being equivalent to the paired Uplink band gain limit.

Test Setup

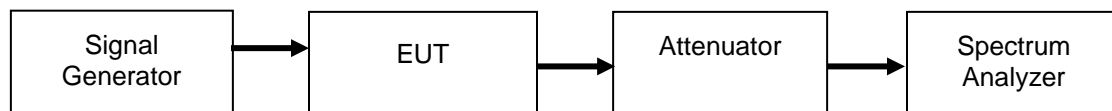

Uplink Power Test Results for 100 Foot Cable

Frequency Band (MHz)	Input Level (dBm)	Output Power (dBm)	Lower Limit (dBm)	Upper Limit (dBm)	Antenna Gain (dBi)	EIRP (dBm)	Result
698 - 716 MHz Pulsed GSM	-36.7	24.7	17	30	4.5	29.2	Pass
698 - 716 MHz AWGN	-40.9	19.6	17	30	4.5	24.1	Pass
776 - 787 MHz Pulsed GSM	-35.9	24.7	17	30	4.2	28.9	Pass
776 - 787 MHz AWGN	-41.0	19.0	17	30	4.2	23.2	Pass
824 - 849 MHz Pulsed GSM	-37.5	24.3	17	30	4.9	29.2	Pass
824 - 849 MHz AWGN	-42.4	18.5	17	30	4.9	23.4	Pass
1710 - 1755 MHz Pulsed GSM	-40.5	25.0	17	30	3.81	28.81	Pass
1710 - 1755 MHz AWGN	-48.4	18.5	17	30	3.81	22.31	Pass
1850 - 1915 MHz Pulsed GSM	-44.2	24.5	17	30	4.74	29.24	Pass
1850 - 1915 MHz AWGN	-48.4	19.5	17	30	4.74	24.24	Pass

Downlink Power Test Results for 100 Foot Cable

Frequency Band (MHz)	Input Level (dBm)	Output Power (dBm)	Upper Limit (dBm)	Antenna Gain (dBi)	EIRP (dBm)	Result
728 - 746 MHz Pulsed GSM	-47.8	14.5	17	-0.8	13.7	Pass
728 - 746 MHz AWGN	-47.5	14.2	17	-0.8	13.4	Pass
746 - 757 MHz Pulsed GSM	-48.9	13.7	17	-1.12	12.58	Pass
746 - 757 MHz AWGN	-48.6	13.5	17	-1.12	12.38	Pass
869 - 894 MHz Pulsed GSM	-49.6	15.2	17	-0.77	14.43	Pass
869 - 894 MHz AWGN	-51.4	12.5	17	-0.77	11.73	Pass
1930 - 1995 MHz Pulsed GSM	-56.2	15.0	17	-0.1	14.9	Pass
1930 - 1995 MHz AWGN	-61.0	9.4	17	-0.1	9.3	Pass
2110 - 2155 MHz Pulsed GSM	-55.7	13.5	17	1.47	14.97	Pass
2110 - 2155 MHz AWGN	-58.1	10.7	17	1.47	12.17	Pass

Uplink and Downlink Gain Test Results for 100 Foot Cable

Modulation	Uplink Frequency (MHz)	Downlink Frequency (MHz)	Uplink Gain (dB)	Uplink Limit (dB)	Downlink Gain (dB)	Downlink Limit (dB)	Delta (dB)	Limit (dB)	Margin (dB)
Pulsed GSM	710.85	737.3	61.4	63.5	62.3	63.5	0.9	9	-8.1
AWGN	710.85	737.3	60.5	63.5	61.7	63.5	1.2	9	-7.8
Pulsed GSM	780.25	747.6	60.6	64.4	62.6	64.4	2	9	-7
AWGN	780.25	747.6	60.0	64.4	62.1	64.4	2.1	9	-6.9
Pulsed GSM	833	876.9	61.8	64.9	64.8	64.9	3	9	-6
AWGN	833	876.9	60.9	64.9	63.9	64.9	3	9	-6
Pulsed GSM	1733.35	2127.55	65.5	71	69.2	71	3.7	9	-5.3
AWGN	1733.35	2127.55	66.9	71	68.8	71	1.9	9	-7.1
Pulsed GSM	1882.7	1952.55	68.7	72	71.2	72	2.5	9	-6.5
AWGN	1882.7	1952.55	67.9	72	70.4	72	2.5	9	-6.5

Maximum Input Power Test for 100 Foot Cable

Frequency Band (MHz)	Maximum Input Level (dBm)	Output Power at Maximum Input Power (dBm)	Lower Limit (dBm)	Upper Limit (dBm)	Result
698 - 716 MHz Pulsed GSM	0.0	24.3	17	30	Pass
698 - 716 MHz AWGN	0.0	19.4	17	30	Pass
776 - 787 MHz Pulsed GSM	0.0	24.6	17	30	Pass
776 - 787 MHz AWGN	0.0	19.0	17	30	Pass
824 - 849 MHz Pulsed GSM	0.0	24.0	17	30	Pass
824 - 849 MHz AWGN	0.0	18.6	17	30	Pass
1710 - 1755 MHz Pulsed GSM	0.0	25.0	17	30	Pass
1710 - 1755 MHz AWGN	0.0	18.2	17	30	Pass
1850 - 1915 MHz Pulsed GSM	0.0	24.2	17	30	Pass
1850 - 1915 MHz AWGN	0.0	19.6	17	30	Pass

Frequency Band (MHz)	Maximum Input Level (dBm)	Output Power at Maximum Input Power (dBm)	Upper Limit (dBm)	Result
728 - 746 MHz Pulsed GSM	-20.0	13.1	17	Pass
728 - 746 MHz AWGN	-20.0	13.5	17	Pass
746 - 757 MHz Pulsed GSM	-20.0	12.4	17	Pass
746 - 757 MHz AWGN	-20.0	13.1	17	Pass
869 - 894 MHz Pulsed GSM	-20.0	14.1	17	Pass
869 - 894 MHz AWGN	-20.0	11.9	17	Pass
1930 - 1995 MHz Pulsed GSM	-20.0	14.9	17	Pass
1930 - 1995 MHz AWGN	-20.0	8.1	17	Pass
2110 - 2155 MHz Pulsed GSM	-20.0	15.3	17	Pass
2110 - 2155 MHz AWGN	-20.0	10.8	17	Pass

Uplink Power Test Results for 300 Foot Cable

Frequency Band (MHz)	Input Level (dBm)	Output Power (dBm)	Lower Limit (dBm)	Upper Limit (dBm)	Antenna Gain (dBi)	EIRP (dBm)	Result
698 - 716 MHz Pulsed GSM	-37.8	24.5	17	30	4.5	29	Pass
698 - 716 MHz AWGN	-42.3	19.4	17	30	4.5	23.9	Pass
776 - 787 MHz Pulsed GSM	-36.4	24.5	17	30	4.2	28.7	Pass
776 - 787 MHz AWGN	-41.5	19.0	17	30	4.2	23.2	Pass
824 - 849 MHz Pulsed GSM	-37.8	24.2	17	30	4.9	29.1	Pass
824 - 849 MHz AWGN	-43.1	18.4	17	30	4.9	23.3	Pass
1710 - 1755 MHz Pulsed GSM	-42.8	25.1	17	30	3.81	28.91	Pass
1710 - 1755 MHz AWGN	-50.7	17.8	17	30	3.81	21.61	Pass
1850 - 1915 MHz Pulsed GSM	-43.8	24.3	17	30	4.74	29.04	Pass
1850 - 1915 MHz AWGN	-48.8	19.4	17	30	4.74	24.14	Pass

Downlink Power Test Results for 300 Foot Cable

Frequency Band (MHz)	Input Level (dBm)	Output Power (dBm)	Upper Limit (dBm)	Antenna Gain (dBi)	EIRP (dBm)	Result
728 - 746 MHz Pulsed GSM	-47.4	14.5	17	-0.8	13.7	Pass
728 - 746 MHz AWGN	-47.4	14.1	17	-0.8	13.3	Pass
746 - 757 MHz Pulsed GSM	-49.0	13.7	17	-1.12	12.58	Pass
746 - 757 MHz AWGN	-48.3	13.4	17	-1.12	12.28	Pass
869 - 894 MHz Pulsed GSM	-49.6	13.7	17	-0.77	12.93	Pass
869 - 894 MHz AWGN	-51.4	11.6	17	-0.77	10.83	Pass
1930 - 1995 MHz Pulsed GSM	-56.1	13.4	17	-0.1	13.3	Pass
1930 - 1995 MHz AWGN	-60.9	8.2	17	-0.1	8.1	Pass
2110 - 2155 MHz Pulsed GSM	-55.8	11.3	17	1.47	12.77	Pass
2110 - 2155 MHz AWGN	-58.0	8.8	17	1.47	10.27	Pass

Uplink and Downlink Gain Test Results for 300 Foot Cable

Modulation	Uplink Frequency (MHz)	Downlink Frequency (MHz)	Uplink Gain (dB)	Uplink Limit (dB)	Downlink Gain (dB)	Downlink Limit (dB)	Delta (dB)	Limit (dB)	Margin (dB)
Pulsed GSM	710.6875	737.225	62.3	63.5	61.9	63.5	0.4	9	-8.6
AWGN	710.6875	737.225	61.7	63.5	61.5	63.5	0.2	9	-8.8
Pulsed GSM	780.8125	747.675	60.9	64.4	62.7	64.4	1.8	9	-7.2
AWGN	780.8125	747.675	60.5	64.4	61.7	64.4	1.2	9	-7.8
Pulsed GSM	832.9375	877.225	62.0	64.9	63.3	64.9	1.3	9	-7.7
AWGN	832.9375	877.225	61.5	64.9	63.0	64.9	1.5	9	-7.5
Pulsed GSM	1753.675	2127.4125	67.9	71	67.1	71	0.8	9	-8.2
AWGN	1753.675	2127.4125	68.5	71	66.8	71	1.7	9	-7.3
Pulsed GSM	1882.75	1973.75	68.1	72	69.5	72	1.4	9	-7.6
AWGN	1882.75	1973.75	68.2	72	69.1	72	0.9	9	-8.1

Maximum Input Power Test for 300 Foot Cable

Frequency Band (MHz)	Maximum Input Level (dBm)	Output Power at Maximum Input Power (dBm)	Lower Limit (dBm)	Upper Limit (dBm)	Result
698 - 716 MHz Pulsed GSM	0.0	24.5	17	30	Pass
698 - 716 MHz AWGN	0.0	19.0	17	30	Pass
776 - 787 MHz Pulsed GSM	0.0	24.5	17	30	Pass
776 - 787 MHz AWGN	0.0	18.8	17	30	Pass
824 - 849 MHz Pulsed GSM	0.0	23.9	17	30	Pass
824 - 849 MHz AWGN	0.0	18.2	17	30	Pass
1710 - 1755 MHz Pulsed GSM	0.0	25.3	17	30	Pass
1710 - 1755 MHz AWGN	0.0	17.0	17	30	Pass
1850 - 1915 MHz Pulsed GSM	0.0	24.1	17	30	Pass
1850 - 1915 MHz AWGN	0.0	19.4	17	30	Pass

Frequency Band (MHz)	Maximum Input Level (dBm)	Output Power at Maximum Input Power (dBm)	Upper Limit (dBm)	Result
728 - 746 MHz Pulsed GSM	-20.0	14.8	17	Pass
728 - 746 MHz AWGN	-20.0	14.6	17	Pass
746 - 757 MHz Pulsed GSM	-20.0	14.3	17	Pass
746 - 757 MHz AWGN	-20.0	13.9	17	Pass
869 - 894 MHz Pulsed GSM	-20.0	14.9	17	Pass
869 - 894 MHz AWGN	-20.0	12.4	17	Pass
1930 - 1995 MHz Pulsed GSM	-20.0	15.1	17	Pass
1930 - 1995 MHz AWGN	-20.0	8.1	17	Pass
2110 - 2155 MHz Pulsed GSM	-20.0	15.0	17	Pass
2110 - 2155 MHz AWGN	-20.0	10.1	17	Pass

Uplink Power Test Results for 200 Foot Cable

Frequency Band (MHz)	Input Level (dBm)	Output Power (dBm)	Lower Limit (dBm)	Upper Limit (dBm)	Antenna Gain (dBi)	EIRP (dBm)	Result
698 - 716 MHz Pulsed GSM	-37.6	24.7	17	30	4.5	29.2	Pass
698 - 716 MHz AWGN	-41.7	19.2	17	30	4.5	23.7	Pass
776 - 787 MHz Pulsed GSM	-36.2	24.7	17	30	4.2	28.9	Pass
776 - 787 MHz AWGN	-41.2	19.2	17	30	4.2	23.4	Pass
824 - 849 MHz Pulsed GSM	-36.4	24.4	17	30	4.9	29.3	Pass
824 - 849 MHz AWGN	-42.9	18.2	17	30	4.9	23.1	Pass
1710 - 1755 MHz Pulsed GSM	-42.2	25.1	17	30	3.81	28.9	Pass
1710 - 1755 MHz AWGN	-50.5	17.2	17	30	3.81	21.1	Pass
1850 - 1915 MHz Pulsed GSM	-43.4	24.3	17	30	4.74	29.1	Pass
1850 - 1915 MHz AWGN	-49.4	18.6	17	30	4.74	23.3	Pass

Downlink Power Test Results for 200 Foot Cable

Frequency Band (MHz)	Input Level (dBm)	Output Power (dBm)	Upper Limit (dBm)	Antenna Gain (dBi)	EIRP (dBm)	Result
728 - 746 MHz Pulsed GSM	-46.8	14.4	17	-0.8	13.6	Pass
728 - 746 MHz AWGN	-47.1	14.8	17	-0.8	14.0	Pass
746 - 757 MHz Pulsed GSM	-47.8	13.3	17	-1.12	12.2	Pass
746 - 757 MHz AWGN	-47.9	14.0	17	-1.12	12.9	Pass
869 - 894 MHz Pulsed GSM	-48.4	15.6	17	-0.77	14.8	Pass
869 - 894 MHz AWGN	-51.3	13.5	17	-0.77	12.8	Pass
1930 - 1995 MHz Pulsed GSM	-55.1	13.1	17	-0.1	13.0	Pass
1930 - 1995 MHz AWGN	-60.5	9.0	17	-0.1	8.9	Pass
2110 - 2155 MHz Pulsed GSM	-54.1	13.3	17	1.47	14.8	Pass
2110 - 2155 MHz AWGN	-57.8	11.4	17	1.47	12.9	Pass

Uplink and Downlink Gain Test Results for 200 Foot Cable

Modulation	Uplink Frequency (MHz)	Downlink Frequency (MHz)	Uplink Gain (dB)	Uplink Limit (dB)	Downlink Gain (dB)	Downlink Limit (dB)	Delta (dB)	Limit (dB)	Margin (dB)
Pulsed GSM	710.75	737.45	62.3	63.5	61.2	63.5	1.1	9	-7.9
AWGN	710.75	737.45	60.9	63.5	61.9	63.5	0.98	9	-8.02
Pulsed GSM	780.875	748.1	60.9	64.4	61.1	64.4	0.23	9	-8.77
AWGN	780.875	748.1	60.4	64.4	61.9	64.4	1.51	9	-7.49
Pulsed GSM	833	877.3	60.8	64.9	64.0	64.9	3.23	9	-5.77
AWGN	833	877.3	61.1	64.9	64.8	64.9	3.73	9	-5.27
Pulsed GSM	1753.5	2126.45	67.2	71	67.4	71	0.23	9	-8.77
AWGN	1753.5	2126.45	67.8	71	69.2	71	1.4	9	-7.6
Pulsed GSM	1879.475	1973.5	67.7	72	68.2	72	0.51	9	-8.49
AWGN	1879.475	1973.5	68.0	72	69.5	72	1.52	9	-7.48

Maximum Input Power Test for 200 Foot Cable

Frequency Band (MHz)	Maximum Input Level (dBm)	Output Power at Maximum Input Power (dBm)	Lower Limit (dBm)	Upper Limit (dBm)	Result
698 - 716 MHz Pulsed GSM	0.0	23.1	17	30	Pass
698 - 716 MHz AWGN	0.0	17.5	17	30	Pass
776 - 787 MHz Pulsed GSM	0.0	24.7	17	30	Pass
776 - 787 MHz AWGN	0.0	19.1	17	30	Pass
824 - 849 MHz Pulsed GSM	0.0	23.8	17	30	Pass
824 - 849 MHz AWGN	0.0	18.5	17	30	Pass
1710 - 1755 MHz Pulsed GSM	0.0	24.9	17	30	Pass
1710 - 1755 MHz AWGN	0.0	17.0	17	30	Pass
1850 - 1915 MHz Pulsed GSM	0.0	23.9	17	30	Pass
1850 - 1915 MHz AWGN	0.0	19.6	17	30	Pass

Frequency Band (MHz)	Maximum Input Level (dBm)	Output Power at Maximum Input Power (dBm)	Upper Limit (dBm)	Result
728 - 746 MHz Pulsed GSM	-20.0	14.0	17	Pass
728 - 746 MHz AWGN	-20.0	14.5	17	Pass
746 - 757 MHz Pulsed GSM	-20.0	12.8	17	Pass
746 - 757 MHz AWGN	-20.0	13.9	17	Pass
869 - 894 MHz Pulsed GSM	-20.0	15.1	17	Pass
869 - 894 MHz AWGN	-20.0	13.5	17	Pass
1930 - 1995 MHz Pulsed GSM	-20.0	12.7	17	Pass
1930 - 1995 MHz AWGN	-20.0	9.0	17	Pass
2110 - 2155 MHz Pulsed GSM	-20.0	13.0	17	Pass
2110 - 2155 MHz AWGN	-20.0	11.5	17	Pass

Intermodulation

Engineer: Greg Corbin

Test Date: 1/26/2017

Test Procedure

The EUT was connected to a spectrum analyzer through an attenuator. Two signal generators were utilized to produce two CW signals 600 kHz apart and centered in the operational band. Attenuator and cable insertion loss correction factors were input to either the signal generator or the spectrum analyzer as required to ensure that accurate measurements were recorded. The input power was set at the maximum allowable power and the RMS intermodulation products were measured to ensure they were less than -19 dBm in a 3 kHz RBW. The uplink and downlink intermodulation products were plotted, with the levels being listed in the summary tables.

The input power was increased in 2 dB increments to 10 dB above the AGC threshold and to verify the intermod products remain below the limit. During this test, the input power was not increased past the maximum allowed. The Intermodulation level was recorded

Test Setup

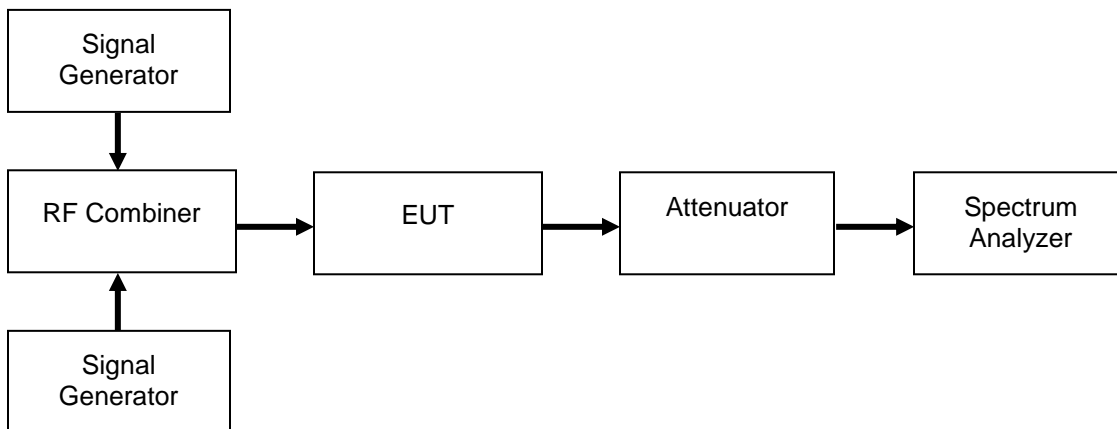

Uplink Test Results for 100 Foot Cable

Frequency Band (MHz)	Intermodulation Level (dBm)	Limit (dBm)	Result	Intermod Level with Input Power @ AGC + 10 dB	Result (Pass / Fail)
698 - 716 MHz	-20	-19	Pass	-20.3	Pass
776 - 787 MHz	-23.4	-19	Pass	-24	Pass
824 - 849 MHz	-19.2	-19	Pass	-19.1	Pass
1710 - 1755 MHz	-19.4	-19	Pass	-19.3	Pass
1850 - 1915 MHz	-20.5	-19	Pass	-20.2	Pass

Downlink Test Results for 100 Foot Cable

Frequency Band (MHz)	Intermodulation Level (dBm)	Limit (dBm)	Result	Intermod Level with Input Power @ AGC + 10 dB	Result (Pass / Fail)
728 - 746 MHz	-32.7	-19	Pass	-32.1	Pass
746 - 757 MHz	-33.2	-19	Pass	-32.4	Pass
869 - 894 MHz	-36.7	-19	Pass	-37.2	Pass
1930 - 1995 MHz	-36.4	-19	Pass	-36	Pass
2110 - 2155 MHz	-34.6	-19	Pass	-34.2	Pass

Uplink Test Results for 300 Foot Cable

Frequency Band (MHz)	Intermodulation Level (dBm)	Limit (dBm)	Result	Intermod Level with Input Power @ AGC + 10 dB	Result (Pass / Fail)
698 - 716 MHz	-19.4	-19	Pass	-19.2	Pass
776 - 787 MHz	-21.8	-19	Pass	-22.6	Pass
824 - 849 MHz	-19.6	-19	Pass	-19.6	Pass
1710 - 1755 MHz	-23	-19	Pass	-22.4	Pass
1850 - 1915 MHz	-20.7	-19	Pass	-20.5	Pass

Downlink Test Results for 300 Foot Cable

Frequency Band (MHz)	Intermodulation Level (dBm)	Limit (dBm)	Result	Intermod Level with Input Power @ AGC + 10 dB	Result (Pass / Fail)
728 - 746 MHz	-33	-19	Pass	-32.3	Pass
746 - 757 MHz	-33	-19	Pass	-32.4	Pass
869 - 894 MHz	-38.4	-19	Pass	-39	Pass
1930 - 1995 MHz	-33.4	-19	Pass	-36.2	Pass
2110 - 2155 MHz	-34.7	-19	Pass	-36	Pass

Uplink Test Results for 200 Foot Cable

Frequency Band (MHz)	Intermodulation Level (dBm)	Limit (dBm)	Result	Intermod Level with Input Power @ AGC + 10 dB	Result (Pass / Fail)
698 - 716 MHz	-19.43	-19	Pass	-19.54	Pass
776 - 787 MHz	-22.27	-19	Pass	-26.1	Pass
824 - 849 MHz	-19.75	-19	Pass	-19.6	Pass
1710 - 1755 MHz	-24.1	-19	Pass	-23.89	Pass
1850 - 1915 MHz	-22.02	-19	Pass	-21.36	Pass

Downlink Test Results for 200 Foot Cable

Frequency Band (MHz)	Intermodulation Level (dBm)	Limit (dBm)	Result	Intermod Level with Input Power @ AGC + 10 dB	Result (Pass / Fail)
728 - 746 MHz	-30.28	-19	Pass	-29.81	Pass
746 - 757 MHz	-31.06	-19	Pass	-30.25	Pass
869 - 894 MHz	-36.16	-19	Pass	-35.93	Pass
1930 - 1995 MHz	-32.74	-19	Pass	-32.51	Pass
2110 - 2155 MHz	-32.23	-19	Pass	-32.24	Pass

Refer to Annex B for Intermodulation test plots

Out-of-Band Emissions

Engineer: Greg Corbin

Test Date: 6/3/2017

Test Procedure

The EUT was connected to a spectrum analyzer through an attenuator with the losses being input into the spectrum analyzer as a combination of reference level offset and correction factor in order to ensure accurate readings. A signal generator was utilized to produce the following signals: GSM, CDMA, and WCDMA. The signal generator was tuned to the lowest allowable upper and lower channel within the EUT operational band for each respective modulation type. The RF input level was increased to a point just prior to the AGC being in control of the power. For each modulation type the Out of Band Emissions were measured to ensure they met the limits.

The following formula was used for calculating the limits:

$$\text{Limit} = P1 - 6 - (43 + 10\text{Log}(P2)) = -19\text{dBm}$$

P1 = power in dBm

P2 = power in Watts

The input power was increased in 2 dB steps up to the maximum input power for the booster being tested. The OOB limit was verified to stay below the OOB limit. This was recorded as Pass / Fail in the OOB tables.

Test Setup



GSM Uplink Test Results for 100 Foot Cable

Frequency Band (MHz)	Band Edge	Measured Level (dBm)	Limit (dBm)	Result	Oobe Below Limit at Max Input Power (Yes / No)
698 - 716	Lower	-34.5	-19	Pass	Yes
698 - 716	Upper	-34.9	-19	Pass	Yes
776 - 787	Lower	-28.6	-19	Pass	Yes
776 - 787	Upper	-31.6	-19	Pass	Yes
824 - 849	Lower	-41.7	-19	Pass	Yes
824 - 849	Upper	-41.7	-19	Pass	Yes
1710 - 1755	Lower	-44.1	-19	Pass	Yes
1710 - 1755	Upper	-40.2	-19	Pass	Yes
1850 - 1915	Lower	-37.5	-19	Pass	Yes
1850 - 1915	Upper	-70.6	-19	Pass	Yes

CDMA Uplink Test Results for 100 Foot Cable

Frequency Band (MHz)	Band Edge	Measured Level (dBm)	Limit (dBm)	Result	Oobe Below Limit at Max Input Power (Yes / No)
698 - 716	Lower	-37.5	-19	Pass	Yes
698 - 716	Upper	-39.8	-19	Pass	Yes
776 - 787	Lower	-39.8	-19	Pass	Yes
776 - 787	Upper	-42.6	-19	Pass	Yes
824 - 849	Lower	-40.0	-19	Pass	Yes
824 - 849	Upper	-42.9	-19	Pass	Yes
1710 - 1755	Lower	-50.8	-19	Pass	Yes
1710 - 1755	Upper	-48.5	-19	Pass	Yes
1850 - 1915	Lower	-46.6	-19	Pass	Yes
1850 - 1915	Upper	-60.9	-19	Pass	Yes

WCDMA Uplink Test Results for 100 Foot Cable

Frequency Band (MHz)	Band Edge	Measured Level (dBm)	Limit (dBm)	Result	Oobe Below Limit at Max Input Power (Yes / No)
698 - 716	Lower	-35.7	-19	Pass	Yes
698 - 716	Upper	-40.5	-19	Pass	Yes
776 - 787	Lower	-44.2	-19	Pass	Yes
776 - 787	Upper	-45.0	-19	Pass	Yes
824 - 849	Lower	-43.0	-19	Pass	Yes
824 - 849	Upper	-42.7	-19	Pass	Yes
1710 - 1755	Lower	-50.8	-19	Pass	Yes
1710 - 1755	Upper	-46.8	-19	Pass	Yes
1850 - 1915	Lower	-38.7	-19	Pass	Yes
1850 - 1915	Upper	-55.5	-19	Pass	Yes

GSM Downlink Test Results for 100 Foot Cable

Frequency Band (MHz)	Band Edge	Measured Level (dBm)	Limit (dBm)	Result	Oobe Below Limit at Max Input Power (Yes / No)
728 - 746 MHz	Lower	-43.8	-19	Pass	Yes
728 - 746 MHz	Upper	-33.0	-19	Pass	Yes
746 - 757 MHz	Lower	-32.4	-19	Pass	Yes
746 - 757 MHz	Upper	-44.1	-19	Pass	Yes
869 - 894 MHz	Lower	-45.4	-19	Pass	Yes
869 - 894 MHz	Upper	-47.7	-19	Pass	Yes
1930 - 1995 MHz	Lower	-53.6	-19	Pass	Yes
1930 - 1995 MHz	Upper	-72.2	-19	Pass	Yes
2110 - 2155 MHz	Lower	-49.8	-19	Pass	Yes
2110 - 2155 MHz	Upper	-52.1	-19	Pass	Yes

CDMA Downlink Test Results for 100 Foot Cable

Frequency Band (MHz)	Band Edge	Measured Level (dBm)	Limit (dBm)	Result	Oobe Below Limit at Max Input Power (Yes / No)
728 - 746 MHz	Lower	-52.4	-19	Pass	Yes
728 - 746 MHz	Upper	-46.5	-19	Pass	Yes
746 - 757 MHz	Lower	-48.1	-19	Pass	Yes
746 - 757 MHz	Upper	-54.2	-19	Pass	Yes
869 - 894 MHz	Lower	-52.5	-19	Pass	Yes
869 - 894 MHz	Upper	-63.1	-19	Pass	Yes
1930 - 1995 MHz	Lower	-63.5	-19	Pass	Yes
1930 - 1995 MHz	Upper	-59.6	-19	Pass	Yes
2110 - 2155 MHz	Lower	-54.2	-19	Pass	Yes
2110 - 2155 MHz	Upper	-54.9	-19	Pass	Yes

WCDMA Downlink Test Results for 100 Foot Cable

Frequency Band (MHz)	Band Edge	Measured Level (dBm)	Limit (dBm)	Result	Oobe Below Limit at Max Input Power (Yes / No)
728 - 746 MHz	Lower	-53.9	-19	Pass	Yes
728 - 746 MHz	Upper	-48.0	-19	Pass	Yes
746 - 757 MHz	Lower	-49.6	-19	Pass	Yes
746 - 757 MHz	Upper	-53.6	-19	Pass	Yes
869 - 894 MHz	Lower	-53.1	-19	Pass	Yes
869 - 894 MHz	Upper	-57.7	-19	Pass	Yes
1930 - 1995 MHz	Lower	-57.4	-19	Pass	Yes
1930 - 1995 MHz	Upper	-55.0	-19	Pass	Yes
2110 - 2155 MHz	Lower	-49.5	-19	Pass	Yes
2110 - 2155 MHz	Upper	-52.3	-19	Pass	Yes

GSM Uplink Test Results for 300 Foot Cable

Frequency Band (MHz)	Band Edge	Measured Level (dBm)	Limit (dBm)	Result	Oobe Below Limit at Max Input Power (Yes / No)
698 - 716	Lower	-34.4	-19	Pass	Yes
698 - 716	Upper	-34.2	-19	Pass	Yes
776 - 787	Lower	-29.2	-19	Pass	Yes
776 - 787	Upper	-32.0	-19	Pass	Yes
824 - 849	Lower	-41.7	-19	Pass	Yes
824 - 849	Upper	-41.6	-19	Pass	Yes
1710 - 1755	Lower	-46.7	-19	Pass	Yes
1710 - 1755	Upper	-39.0	-19	Pass	Yes
1850 - 1915	Lower	-38.5	-19	Pass	Yes
1850 - 1915	Upper	-43.5	-19	Pass	Yes

CDMA Uplink Test Results for 300 Foot Cable

Frequency Band (MHz)	Band Edge	Measured Level (dBm)	Limit (dBm)	Result	Oobe Below Limit at Max Input Power (Yes / No)
698 - 716	Lower	-37.6	-19	Pass	Yes
698 - 716	Upper	-39.6	-19	Pass	Yes
776 - 787	Lower	-39.8	-19	Pass	Yes
776 - 787	Upper	-43.8	-19	Pass	Yes
824 - 849	Lower	-43.6	-19	Pass	Yes
824 - 849	Upper	-44.7	-19	Pass	Yes
1710 - 1755	Lower	-53.2	-19	Pass	Yes
1710 - 1755	Upper	-46.0	-19	Pass	Yes
1850 - 1915	Lower	-44.2	-19	Pass	Yes
1850 - 1915	Upper	-60.9	-19	Pass	Yes

WCDMA Uplink Test Results for 300 Foot Cable

Frequency Band (MHz)	Band Edge	Measured Level (dBm)	Limit (dBm)	Result	Oobe Below Limit at Max Input Power (Yes / No)
698 - 716	Lower	-36.0	-19	Pass	Yes
698 - 716	Upper	-40.6	-19	Pass	Yes
776 - 787	Lower	-44.3	-19	Pass	Yes
776 - 787	Upper	-45.3	-19	Pass	Yes
824 - 849	Lower	-43.4	-19	Pass	Yes
824 - 849	Upper	-45.4	-19	Pass	Yes
1710 - 1755	Lower	-48.8	-19	Pass	Yes
1710 - 1755	Upper	-42.4	-19	Pass	Yes
1850 - 1915	Lower	-40.8	-19	Pass	Yes
1850 - 1915	Upper	-55.7	-19	Pass	Yes

GSM Downlink Test Results for 300 Foot Cable

Frequency Band (MHz)	Band Edge	Measured Level (dBm)	Limit (dBm)	Result	Oobe Below Limit at Max Input Power (Yes / No)
728 - 746 MHz	Lower	-44.3	-19	Pass	Yes
728 - 746 MHz	Upper	-33.3	-19	Pass	Yes
746 - 757 MHz	Lower	-32.6	-19	Pass	Yes
746 - 757 MHz	Upper	-44.0	-19	Pass	Yes
869 - 894 MHz	Lower	-45.8	-19	Pass	Yes
869 - 894 MHz	Upper	-47.4	-19	Pass	Yes
1930 - 1995 MHz	Lower	-59.4	-19	Pass	Yes
1930 - 1995 MHz	Upper	-68.7	-19	Pass	Yes
2110 - 2155 MHz	Lower	-53	-19	Pass	Yes
2110 - 2155 MHz	Upper	-53.7	-19	Pass	Yes

CDMA Downlink Test Results for 300 Foot Cable

Frequency Band (MHz)	Band Edge	Measured Level (dBm)	Limit (dBm)	Result	Oobe Below Limit at Max Input Power (Yes / No)
728 - 746 MHz	Lower	-52.8	-19	Pass	Yes
728 - 746 MHz	Upper	-47.2	-19	Pass	Yes
746 - 757 MHz	Lower	-48.3	-19	Pass	Yes
746 - 757 MHz	Upper	-54.1	-19	Pass	Yes
869 - 894 MHz	Lower	-52.5	-19	Pass	Yes
869 - 894 MHz	Upper	-63.7	-19	Pass	Yes
1930 - 1995 MHz	Lower	-64.3	-19	Pass	Yes
1930 - 1995 MHz	Upper	-59.0	-19	Pass	Yes
2110 - 2155 MHz	Lower	-57.9	-19	Pass	Yes
2110 - 2155 MHz	Upper	-57.5	-19	Pass	Yes

WCDMA Downlink Test Results for 300 Foot Cable

Frequency Band (MHz)	Band Edge	Measured Level (dBm)	Limit (dBm)	Result	Oobe Below Limit at Max Input Power (Yes / No)
728 - 746 MHz	Lower	-53.7	-19	Pass	Yes
728 - 746 MHz	Upper	-47.8	-19	Pass	Yes
746 - 757 MHz	Lower	-49.9	-19	Pass	Yes
746 - 757 MHz	Upper	-53.7	-19	Pass	Yes
869 - 894 MHz	Lower	-52.7	-19	Pass	Yes
869 - 894 MHz	Upper	-57.8	-19	Pass	Yes
1930 - 1995 MHz	Lower	-58.5	-19	Pass	Yes
1930 - 1995 MHz	Upper	-54.4	-19	Pass	Yes
2110 - 2155 MHz	Lower	-51.2	-19	Pass	Yes
2110 - 2155 MHz	Upper	-54.4	-19	Pass	Yes

GSM Uplink Test Results for 200 Foot Cable

Frequency Band (MHz)	Band Edge	Measured Level (dBm)	Limit (dBm)	Result	Oobe Below Limit at Max Input Power (Yes / No)
698 - 716	Lower	-27.6	-19	Pass	Yes
698 - 716	Upper	-30.0	-19	Pass	Yes
776 - 787	Lower	-27.3	-19	Pass	Yes
776 - 787	Upper	-27.4	-19	Pass	Yes
824 - 849	Lower	-32.1	-19	Pass	Yes
824 - 849	Upper	-41.4	-19	Pass	Yes
1710 - 1755	Lower	-41.3	-19	Pass	Yes
1710 - 1755	Upper	-38.3	-19	Pass	Yes
1850 - 1915	Lower	-36.7	-19	Pass	Yes
1850 - 1915	Upper	-38.3	-19	Pass	Yes

CDMA Uplink Test Results for 200 Foot Cable

Frequency Band (MHz)	Band Edge	Measured Level (dBm)	Limit (dBm)	Result	Oobe Below Limit at Max Input Power (Yes / No)
698 - 716	Lower	-35.9	-19	Pass	Yes
698 - 716	Upper	-37.6	-19	Pass	Yes
776 - 787	Lower	-38.8	-19	Pass	Yes
776 - 787	Upper	-42.9	-19	Pass	Yes
824 - 849	Lower	-49.1	-19	Pass	Yes
824 - 849	Upper	-48.3	-19	Pass	Yes
1710 - 1755	Lower	-46.5	-19	Pass	Yes
1710 - 1755	Upper	-45.6	-19	Pass	Yes
1850 - 1915	Lower	-41.1	-19	Pass	Yes
1850 - 1915	Upper	-51.2	-19	Pass	Yes

WCDMA Uplink Test Results for 200 Foot Cable

Frequency Band (MHz)	Band Edge	Measured Level (dBm)	Limit (dBm)	Result	Oobe Below Limit at Max Input Power (Yes / No)
698 - 716	Lower	-35.7	-19	Pass	Yes
698 - 716	Upper	-39.3	-19	Pass	Yes
776 - 787	Lower	-41.9	-19	Pass	Yes
776 - 787	Upper	-46.1	-19	Pass	Yes
824 - 849	Lower	-44.5	-19	Pass	Yes
824 - 849	Upper	-49.4	-19	Pass	Yes
1710 - 1755	Lower	-51.7	-19	Pass	Yes
1710 - 1755	Upper	-43.5	-19	Pass	Yes
1850 - 1915	Lower	-38.8	-19	Pass	Yes
1850 - 1915	Upper	-52.1	-19	Pass	Yes

GSM Downlink Test Results for 200 Foot Cable

Frequency Band (MHz)	Band Edge	Measured Level (dBm)	Limit (dBm)	Result	Oobe Below Limit at Max Input Power (Yes / No)
728 - 746 MHz	Lower	-43.4	-19	Pass	Yes
728 - 746 MHz	Upper	-33.5	-19	Pass	Yes
746 - 757 MHz	Lower	-32.5	-19	Pass	Yes
746 - 757 MHz	Upper	-41.8	-19	Pass	Yes
869 - 894 MHz	Lower	-44.1	-19	Pass	Yes
869 - 894 MHz	Upper	-45.3	-19	Pass	Yes
1930 - 1995 MHz	Lower	-54.5	-19	Pass	Yes
1930 - 1995 MHz	Upper	-49.5	-19	Pass	Yes
2110 - 2155 MHz	Lower	-47.1	-19	Pass	Yes
2110 - 2155 MHz	Upper	-51.7	-19	Pass	Yes

CDMA Downlink Test Results for 200 Foot Cable

Frequency Band (MHz)	Band Edge	Measured Level (dBm)	Limit (dBm)	Result	Oobe Below Limit at Max Input Power (Yes / No)
728 - 746 MHz	Lower	-55.0	-19	Pass	Yes
728 - 746 MHz	Upper	-45.9	-19	Pass	Yes
746 - 757 MHz	Lower	-47.8	-19	Pass	Yes
746 - 757 MHz	Upper	-55.6	-19	Pass	Yes
869 - 894 MHz	Lower	-54.3	-19	Pass	Yes
869 - 894 MHz	Upper	-59.0	-19	Pass	Yes
1930 - 1995 MHz	Lower	-62.7	-19	Pass	Yes
1930 - 1995 MHz	Upper	-55.1	-19	Pass	Yes
2110 - 2155 MHz	Lower	-52.5	-19	Pass	Yes
2110 - 2155 MHz	Upper	-55.5	-19	Pass	Yes

WCDMA Downlink Test Results for 200 Foot Cable

Frequency Band (MHz)	Band Edge	Measured Level (dBm)	Limit (dBm)	Result	Oobe Below Limit at Max Input Power (Yes / No)
728 - 746 MHz	Lower	-54.8	-19	Pass	Yes
728 - 746 MHz	Upper	-74.3	-19	Pass	Yes
746 - 757 MHz	Lower	-47.6	-19	Pass	Yes
746 - 757 MHz	Upper	-55.1	-19	Pass	Yes
869 - 894 MHz	Lower	-54.9	-19	Pass	Yes
869 - 894 MHz	Upper	-57.5	-19	Pass	Yes
1930 - 1995 MHz	Lower	-58.0	-19	Pass	Yes
1930 - 1995 MHz	Upper	-52.4	-19	Pass	Yes
2110 - 2155 MHz	Lower	-48.3	-19	Pass	Yes
2110 - 2155 MHz	Upper	-52.8	-19	Pass	Yes

Refer to Annex C for Out of Band Emission plots

Conducted Spurious Emissions

Engineer: Greg Corbin

Test Date: 6/3/2017

Test Procedure

The EUT was connected to a spectrum analyzer through an attenuator, with the losses being input into the spectrum analyzer as a combination of reference level offset and correction factor as needed to ensure accurate readings. A signal generator was utilized to produce a 4.1 MHz AWGN signal operating at the maximum allowable power. The conducted spurious emissions from 9 kHz to 10 times the highest tunable frequency for each operational band were measured (excluding the band defined by the Out of band emissions test). The emissions were plotted and the highest level was recorded in the summary table.

The following formulas are used for calculating the limits.

Conducted Spurious Emissions Limit = $P1 - (43 + 10\text{Log}(P2)) = -13 \text{ dBm}$

P1 = power in dBm

P2 = power in Watts

Test Setup

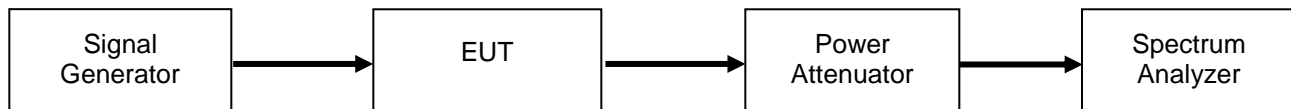

Uplink Test Results for 100 Foot Cable

Frequency Band (MHz)	Measured Frequency (MHz)	Measured Level (dBm)	Limit (dBm)	Result
698 - 716	7304.7	-31.3	-13	Pass
776 - 787	775.9	-26.5	-13	Pass
824 - 849	8342.5	-21.1	-13	Pass
1710 - 1755	17338	-25.6	-13	Pass
1850 - 1915	16669	-25.6	-13	Pass

Downlink Test Results for 100 Foot Cable

Frequency Band (MHz)	Measured Frequency (MHz)	Measured Level (dBm)	Limit (dBm)	Result
728 - 746	1938.16	-29.8	-13	Pass
746 - 757	7375.3	-30.8	-13	Pass
869 - 894	1940.55	-29.8	-13	Pass
1930 - 1995	19774.9	-24.9	-13	Pass
2110 - 2155	21647.7	-24.4	-13	Pass

For the 746 – 758 downlink and 776 – 788 Uplink bands of operation, the following additional spurious emissions requirements apply.

FCC 27.53(c)

For operations in the 746-758 MHz band and the 776-788 MHz band, the power of any emission outside the licensee's frequency band(s) of operation shall be attenuated below the transmitter power (P) within the licensed band(s) of operation, measured in watts, in accordance with the following:

(3) On all frequencies between 763-775 MHz and 793-805 MHz, by a factor not less than $76 + 10 \log (P)$ dB in a 6.25 kHz band segment, for base and fixed stations;

776 – 787 MHz Uplink Band for 100 Foot Cable

Spurious Frequency Range (MHz)	Measured Frequency (MHz)	Measured Value (dBm)	RBW (kHz)	Final Value (dBm)	Limit (dBm)	Margin (dB)
763 – 775	774.95	-54.7	6.25	-54.70	-46	-8.70
793 – 805	793.05	-69	6.25	-69.00	-46	-23.00

746 - 757 MHz Downlink Band for 100 Foot Cable

Spurious Frequency Range (MHz)	Measured Frequency (MHz)	Measured Value (dBm)	RBW (kHz)	Final Value (dBm)	Limit (dBm)	Margin (dB)
763 – 775	774.78	-66.9	6.25	-66.90	-46	-20.90
793 – 805	799.46	-67.1	6.25	-67.10	-46	-21.10

FCC 27.53(e)

For operations in the 746-758 MHz, 775-788 MHz, and 805-806 MHz bands, emissions in the band 1559-1610 MHz shall be limited to -70 dBW/MHz equivalent isotropically radiated power (EIRP) for wideband signals, and -80 dBW EIRP for discrete emissions of less than 700 Hz bandwidth. For the purpose of equipment authorization, a transmitter shall be tested with an antenna that is representative of the type that will be used with the equipment in normal operation.

Since the limit is referenced to EIRP, the final data is computed using the Conducted Spurious Emission data plus the final gain/loss data from the antenna kitting information supplied by the manufacturer.

Final Value (dBm) = conducted measurement + final gain/loss from Antenna Kitting document

The Limit for discreet (narrowband) emissions is -80dBW (-50 dBm) in 700 MHz BW.

The Limit for (wideband Emissions) is -70 dBW (-40 dBm) in a 1 MHz BW.

776 – 787 MHz Uplink Band for 100 Foot Cable

Spurious Frequency Range (MHz)	Measured Frequency (MHz)	Measured Value (dBm)	RBW	Gain/Loss from Antenna Kitting Information (dB)	Final Value (dBm)	Limit (dBm)	Margin (dB)
1559 – 1610 (Wideband)	1563.07	-54.6	1 MHz	4.20	-50.40	-40	-10.40
1559 – 1610 (Narrowband)	1605.21	-81.8	700 Hz	4.20	-77.60	-50	-27.60

746 - 757 MHz Downlink Band for 100 Foot Cable

Spurious Frequency Range (MHz)	Measured Frequency (MHz)	Measured Value (dBm)	RBW	Gain/Loss from Antenna Kitting Information (dB)	Final Value (dBm)	Limit (dBm)	Margin (dB)
1559 – 1610 (Wideband)	1590.54	-51.6	1 MHz	-1.12	-52.72	-40	-12.72
1559 – 1610 (Narrowband)	1575.38	-82.1	700 Hz	-1.12	-83.22	-50	-33.22

Uplink Test Results for 300 Foot Cable

Frequency Band (MHz)	Measured Frequency (MHz)	Measured Level (dBm)	Limit (dBm)	Result
698 - 716	6741.9	-31.3	-13	Pass
776 - 787	787.1	-23.7	-13	Pass
824 - 849	8318.3	-31.9	-13	Pass
1710 - 1755	16948.1	-26.4	-13	Pass
1850 - 1915	15542.3	-24.7	-13	Pass

Downlink Test Results for 300 Foot Cable

Frequency Band (MHz)	Measured Frequency (MHz)	Measured Level (dBm)	Limit (dBm)	Result
728 - 746	1943.2	-29.6	-13	Pass
746 - 757	1942.6	-29.9	-13	Pass
869 - 894	2128.9	-30.7	-13	Pass
1930 - 1995	19770.4	-25.1	-13	Pass
2110 - 2155	21642.7	-24.9	-13	Pass

For the 746 – 758 downlink and 776 – 788 Uplink bands of operation, the following additional spurious emissions requirements apply.

FCC 27.53(c)

For operations in the 746-758 MHz band and the 776-788 MHz band, the power of any emission outside the licensee's frequency band(s) of operation shall be attenuated below the transmitter power (P) within the licensed band(s) of operation, measured in watts, in accordance with the following:

(3) On all frequencies between 763-775 MHz and 793-805 MHz, by a factor not less than $76 + 10 \log (P)$ dB in a 6.25 kHz band segment, for base and fixed stations;

776 – 787 MHz Uplink Band for 300 Foot Cable

Spurious Frequency Range (MHz)	Measured Frequency (MHz)	Measured Value (dBm)	RBW (kHz)	Final Value (dBm)	Limit (dBm)	Margin (dB)
763 – 775	774.943	-53.3	6.25	-53.30	-46	-7.30
793 – 805	793.006	-66.6	6.25	-66.60	-46	-20.60

746 - 757 MHz Downlink Band for 300 Foot Cable

Spurious Frequency Range (MHz)	Measured Frequency (MHz)	Measured Value (dBm)	RBW (kHz)	Final Value (dBm)	Limit (dBm)	Margin (dB)
763 – 775	774.751	-72.6	6.25	-72.60	-46	-26.60
793 – 805	799.465	-72.6	6.25	-72.60	-46	-26.60

FCC 27.53(e)

For operations in the 746-758 MHz, 775-788 MHz, and 805-806 MHz bands, emissions in the band 1559-1610 MHz shall be limited to -70 dBW/MHz equivalent isotropically radiated power (EIRP) for wideband signals, and -80 dBW EIRP for discrete emissions of less than 700 Hz bandwidth. For the purpose of equipment authorization, a transmitter shall be tested with an antenna that is representative of the type that will be used with the equipment in normal operation.

Since the limit is referenced to EIRP, the final data is computed using the Conducted Spurious Emission data plus the final gain/loss data from the antenna kitting information supplied by the manufacturer.

Final Value (dBm) = conducted measurement + final gain/loss from Antenna Kitting document

The Limit for discreet (narrowband) emissions is -80dBW (-50 dBm) in 700 MHz BW.

The Limit for (wideband Emissions) is -70 dBW (-40 dBm) in a 1 MHz BW.

776 – 787 MHz Uplink Band for 300 Foot Cable

Spurious Frequency Range (MHz)	Measured Frequency (MHz)	Measured Value (dBm)	RBW	Gain/Loss from Antenna Kitting Information (dB)	Final Value (dBm)	Limit (dBm)	Margin (dB)
1559 – 1610 (Wideband)	1563.69	-50.9	1 MHz	4.20	-46.70	-40	-6.70
1559 – 1610 (Narrowband)	1587.52	-81.9	700 Hz	4.20	-77.70	-50	-27.70

746 - 757 MHz Downlink Band for 300 Foot Cable

Spurious Frequency Range (MHz)	Measured Frequency (MHz)	Measured Value (dBm)	RBW	Gain/Loss from Antenna Kitting Information (dB)	Final Value (dBm)	Limit (dBm)	Margin (dB)
1559 – 1610 (Wideband)	1589.04	-50.1	1 MHz	-1.12	-51.22	-40	-11.22
1559 – 1610 (Narrowband)	1584.02	-81.6	700 Hz	-1.12	-82.72	-50	-32.72

Uplink Test Results for 200 Foot Cable

Frequency Band (MHz)	Measured Frequency (MHz)	Measured Level (dBm)	Limit (dBm)	Result
698 - 716	716.1	-24.7	-13	Pass
776 - 787	787.1	-23.4	-13	Pass
824 - 849	1749.8	-28.5	-13	Pass
1710 - 1755	781.4	-35.78	-13	Pass
1850 - 1915	1750.2	-29.4	-13	Pass

Downlink Test Results for 200 Foot Cable

Frequency Band (MHz)	Measured Frequency (MHz)	Measured Level (dBm)	Limit (dBm)	Result
728 - 746	1981.2	-29.61	-13	Pass
746 - 757	1972.9	-30.8	-13	Pass
869 - 894	2131	-30.3	-13	Pass
1930 - 1995	878	-33.82	-13	Pass
2110 - 2155	1951.0	-29.4	-13	Pass

For the 746 – 758 downlink and 776 – 788 Uplink bands of operation, the following additional spurious emissions requirements apply.

FCC 27.53(c)

For operations in the 746-758 MHz band and the 776-788 MHz band, the power of any emission outside the licensee's frequency band(s) of operation shall be attenuated below the transmitter power (P) within the licensed band(s) of operation, measured in watts, in accordance with the following:

(3) On all frequencies between 763-775 MHz and 793-805 MHz, by a factor not less than $76 + 10 \log (P)$ dB in a 6.25 kHz band segment, for base and fixed stations;

776 – 787 MHz Uplink Band for 200 Foot Cable

Spurious Frequency Range (MHz)	Measured Frequency (MHz)	Measured Value (dBm)	RBW (kHz)	Final Value (dBm)	Limit (dBm)	Margin (dB)
763 – 775	774.95	-51.5	6.25	-51.5	-46	-5.50
793 – 805	793.05	-58.9	6.25	-58.9	-46	-12.90

746 - 757 MHz Downlink Band for 200 Foot Cable

Spurious Frequency Range (MHz)	Measured Frequency (MHz)	Measured Value (dBm)	RBW (kHz)	Final Value (dBm)	Limit (dBm)	Margin (dB)
763 – 775	774.78	-77.75	6.25	-77.75	-46	-31.75
793 – 805	799.46	-93.5	6.25	-93.50	-46	-47.50

FCC 27.53(e)

For operations in the 746-758 MHz, 775-788 MHz, and 805-806 MHz bands, emissions in the band 1559-1610 MHz shall be limited to -70 dBW/MHz equivalent isotropically radiated power (EIRP) for wideband signals, and -80 dBW EIRP for discrete emissions of less than 700 Hz bandwidth. For the purpose of equipment authorization, a transmitter shall be tested with an antenna that is representative of the type that will be used with the equipment in normal operation.

Since the limit is referenced to EIRP, the final data is computed using the Conducted Spurious Emission data plus the final gain/loss data from the antenna kitting information supplied by the manufacturer.

Final Value (dBm) = conducted measurement + final gain/loss from Antenna Kitting document

The Limit for discreet (narrowband) emissions is -80dBW (-50 dBm) in 700 MHz BW.

The Limit for (wideband Emissions) is -70 dBW (-40 dBm) in a 1 MHz BW.

776 – 787 MHz Uplink Band for 200 Foot Cable

Spurious Frequency Range (MHz)	Measured Frequency (MHz)	Measured Value (dBm)	RBW	Gain/Loss from Antenna Kitting Information (dB)	Final Value (dBm)	Limit (dBm)	Margin (dB)
1559 – 1610 (Wideband)	1563.07	-57.83	1 MHz	4.20	-53.63	-40	-13.63
1559 – 1610 (Narrowband)	1605.21	-80.15	700 Hz	4.20	-75.95	-50	-25.95

746 - 757 MHz Downlink Band for 200 Foot Cable

Spurious Frequency Range (MHz)	Measured Frequency (MHz)	Measured Value (dBm)	RBW	Gain/Loss from Antenna Kitting Information (dB)	Final Value (dBm)	Limit (dBm)	Margin (dB)
1559 – 1610 (Wideband)	1590.54	-71.4	1 MHz	-1.12	-72.52	-40	-32.52
1559 – 1610 (Narrowband)	1575.38	-103.49	700 Hz	-1.12	-104.49	-50	-54.49

Refer to Annex D for Conducted Spurious Emission plots

Noise Limits

Engineer: Greg Corbin

Test Date: 6/3/2017

Test Procedure

The EUT was connected to a spectrum analyzer through an attenuator with the losses being input into the spectrum analyzer as a combination of reference level offset and correction factor as necessary to ensure that accurate readings were obtained. A series of three tests were performed: the maximum uplink and downlink noise, the variable noise for the uplink and downlink in the presence of a downlink signal, and the variable uplink noise timing. The detailed procedures from KDB 935210 D03 v04 were followed.

For all other installations the Noise Limit is calculated using the following formula.

The following formulas are used for calculating the limits. Note – Downlink noise power limit is calculated with the center frequency of the associated uplink band.

Noise Power = $-102.5 + \text{LOG}_{10}(\text{Band Center Frequency}) * 20$

Variable Noise = $-103 \text{ dBm/MHz-RSSI}$

Test Setup

Maximum Noise Power



Variable Uplink Noise Power and Timing

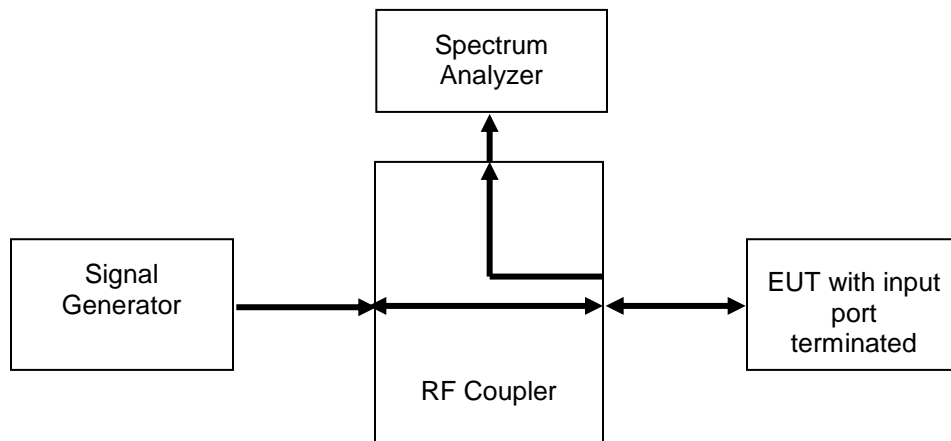

Maximum Uplink Noise Test Results for 100 Foot Cable

Frequency Band (MHz)	Measured Noise (dBm)	Limit (dBm)	Margin (dB)	Result
698 - 716	-46.9	-45.5	-1.4	Pass
776 - 787	-46.1	-44.6	-1.5	Pass
824 - 849	-46.3	-44.1	-2.2	Pass
1710 - 1755	-37.9	-37.7	-0.2	Pass
1850 - 1915	-39.6	-37.0	-2.6	Pass

Maximum Downlink Noise Test Results for 100 Foot Cable

Frequency Band (MHz)	Measured Noise (dBm)	Limit (dBm)	Margin (dB)	Result
728 - 746	-47.1	-45.5	-1.6	Pass
746 - 757	-46.77	-44.6	-2.1	Pass
869 - 894	-44.2	-44.1	-0.1	Pass
1930 - 1995	-37.1	-37.0	-0.1	Pass
2110 - 2155	-39.5	-37.7	-1.8	Pass

Maximum Uplink Noise Test Results for 300 Foot Cable

Frequency Band (MHz)	Measured Noise (dBm)	Limit (dBm)	Margin (dB)	Result
698 - 716	-46.2	-45.5	-0.7	Pass
776 - 787	-45.7	-44.6	-1.1	Pass
824 - 849	-46	-44.1	-1.9	Pass
1710 - 1755	-38.4	-37.7	-0.7	Pass
1850 - 1915	-39.9	-37.0	-2.9	Pass

Maximum Downlink Noise Test Results for 300 Foot Cable

Frequency Band (MHz)	Measured Noise (dBm)	Limit (dBm)	Margin (dB)	Result
728 - 746	-46.5	-45.5	-1.0	Pass
746 - 757	-46.4	-44.6	-1.8	Pass
869 - 894	-44.7	-44.1	-0.6	Pass
1930 - 1995	-38.4	-37.0	-1.4	Pass
2110 - 2155	-41.1	-37.7	-3.4	Pass

Uplink Noise Timing Test Results for 100 Foot Cable

Frequency Band (MHz)	Measured Timing (Seconds)	Limit (Seconds)	Result
698 - 716	1.01	3	Pass
776 - 787	0.96	3	Pass
824 - 849	0.45	3	Pass
1710 - 1755	1.01	3	Pass
1850 - 1915	1.07	3	Pass

Uplink Noise Timing Test Results for 300 Foot Cable

Frequency Band (MHz)	Measured Timing (Seconds)	Limit (Seconds)	Result
698 - 716	1.01	3	Pass
776 - 787	1.01	3	Pass
824 - 849	0.49	3	Pass
1710 - 1755	0.47	3	Pass
1850 - 1915	0.60	3	Pass

Maximum Uplink Noise Test Results for 200 Foot Cable

Frequency Band (MHz)	Measured Noise (dBm)	Limit (dBm)	Margin (dB)	Result
698 - 716	-47.07	-45.5	-1.6	Pass
776 - 787	-45.85	-44.6	-1.2	Pass
824 - 849	-47.32	-44.1	-3.3	Pass
1710 - 1755	-39.26	-37.7	-1.5	Pass
1850 - 1915	-39.27	-37.0	-2.3	Pass

Maximum Downlink Noise Test Results for 200 Foot Cable

Frequency Band (MHz)	Measured Noise (dBm)	Limit (dBm)	Margin (dB)	Result
728 - 746	-47.44	-45.5	-1.9	Pass
746 - 757	-47.66	-44.6	-3.0	Pass
869 - 894	-44.1	-44.1	0.0	Pass
1930 - 1995	-37.52	-37.0	-0.5	Pass
2110 - 2155	-38.46	-37.7	-0.7	Pass

Uplink Noise Timing Test Results for 200 Foot Cable

Frequency Band (MHz)	Measured Timing (Seconds)	Limit (Seconds)	Result
698 - 716	1.03	3	Pass
776 - 787	0.98	3	Pass
824 - 849	1.45	3	Pass
1710 - 1755	0.80	3	Pass
1850 - 1915	0.92	3	Pass

Refer to Annex E for Noise Limits and Uplink Noise Timing Plots

Variable Uplink Noise Limit Test Results for 100 Foot Cable
698 - 716 MHz

RSSI (dBm)	Noise Limit (dBm)	Measured Noise (dBm)	Margin (dB)
-69.0	-45.5	-46.2	-0.7
-65.0	-45.5	-46	-0.5
-64.0	-45.5	-45.8	-0.3
-63.0	-45.5	-46.2	-0.7
-58.0	-45.5	-48.6	-3.1
-57.0	-46.0	-49	-3.0

776 - 787 MHz

RSSI (dBm)	Noise Limit (dBm)	Measured Noise (dBm)	Margin (dB)
-67.0	-44.6	-45	-0.4
-62.0	-44.6	-44.9	-0.3
-61.0	-44.6	-45	-0.4
-60.0	-44.6	-44.8	-0.2
-56.0	-47.0	-47.5	-0.5
-55.0	-48.0	-48.6	-0.6

824 - 849 MHz

RSSI (dBm)	Noise Limit (dBm)	Measured Noise (dBm)	Margin (dB)
-58.0	-45.0	-45.5	-0.5
-57.0	-46.0	-46.4	-0.4
-56.0	-47.0	-47.3	-0.3
-55.0	-48.0	-48.5	-0.5
-53.0	-50.0	-50.5	-0.5
-51.0	-52.0	-52.7	-0.7

1710 - 1755 MHz

RSSI (dBm)	Noise Limit (dBm)	Measured Noise (dBm)	Margin (dB)
-73.0	-37.7	-38.2	-0.5
-72.0	-37.7	-38.2	-0.5
-71.0	-37.7	-38.2	-0.5
-63.0	-40.0	-40.5	-0.5
-62.0	-41.0	-41.4	-0.4
-61.0	-42.0	-42.3	-0.3

1850 - 1915 MHz

RSSI (dBm)	Noise Limit (dBm)	Measured Noise (dBm)	Margin (dB)
-74.0	-37.0	-38.4	-1.4
-73.0	-37.0	-38.4	-1.4
-72.0	-37.0	-38.4	-1.4
-71.0	-37.0	-38.4	-1.4
-67.0	-37.0	-39.2	-2.2
-62.0	-41.0	-44.2	-3.2



Variable Uplink Noise Limit Test Results for 300 Foot Cable

698 - 716 MHz

RSSI (dBm)	Noise Limit (dBm)	Measured Noise (dBm)	Margin (dB)
-74.0	-45.5	-45.8	-0.3
-73.0	-45.5	-45.8	-0.3
-72.0	-45.5	-45.8	-0.3
-71.0	-45.5	-45.8	-0.3
-59.0	-45.5	-47.1	-1.6
-58.0	-45.5	-48.6	-3.1

776 - 787 MHz

RSSI (dBm)	Noise Limit (dBm)	Measured Noise (dBm)	Margin (dB)
-63.0	-44.6	-45	-0.4
-62.0	-44.6	-44.8	-0.2
-60.0	-44.6	-44.7	-0.1
-59.0	-44.6	-44.8	-0.2
-58.0	-45.0	-46.1	-1.1
-57.0	-46.0	-46.7	-0.7

824 - 849 MHz

RSSI (dBm)	Noise Limit (dBm)	Measured Noise (dBm)	Margin (dB)
-58.0	-45.0	-46.2	-1.2
-57.0	-46.0	-47	-1.0
-56.0	-47.0	-48.1	-1.1
-55.0	-48.0	-49	-1.0
-54.0	-49.0	-49.7	-0.7
-53.0	-50.0	-51.4	-1.4

1710 - 1755 MHz

RSSI (dBm)	Noise Limit (dBm)	Measured Noise (dBm)	Margin (dB)
-82.0	-37.7	-38.1	-0.4
-81.0	-37.7	-38.1	-0.4
-69.0	-37.7	-38	-0.3
-64.0	-39.0	-39.3	-0.3
-62.0	-41.0	-41.3	-0.3
-41.0	-62.0	-62.3	-0.3

1850 - 1915 MHz

RSSI (dBm)	Noise Limit (dBm)	Measured Noise (dBm)	Margin (dB)
-84.0	-37.0	-39.4	-2.4
-83.0	-37.0	-39.4	-2.4
-82.0	-37.0	-39.4	-2.4
-81.0	-37.0	-39.4	-2.4
-62.0	-41.0	-44.2	-3.2
-51.0	-52.0	-55.1	-3.1



Variable Uplink Noise Limit Test Results for 200 Foot Cable

698 - 716 MHz

RSSI (dBm)	Noise Limit (dBm)	Measured Noise (dBm)	Margin (dB)
-69	-45.5	-46.5	-1
-64	-45.5	-46.5	-1.1
-66	-45.5	-46.7	-1.2
-62	-45.5	-46.5	-1.1
-58	-45.5	-49.8	-4.4
-57	-46	-51.4	-5.5

776 - 787 MHz

RSSI (dBm)	Noise Limit (dBm)	Measured Noise (dBm)	Margin (dB)
-67.0	-44.6	-45.5	-0.9
-62.0	-44.6	-45.5	-0.9
-61.0	-44.6	-45.2	-0.6
-60.0	-44.6	-45.5	-0.9
-56.0	-47.0	-49.6	-2.6
-33.0	-70.0	-72.0	-2.0

824 - 849 MHz

RSSI (dBm)	Noise Limit (dBm)	Measured Noise (dBm)	Margin (dB)
-27.0	-70.0	-71.7	-1.7
-26.0	-70.0	-71.6	-1.6
-25.0	-70.0	-71.5	-1.5
-24.0	-70.0	-71.7	-1.8
-54.0	-49.0	-52.8	-3.8
-53.0	-50.0	-53.7	-3.7

1710 - 1755 MHz

RSSI (dBm)	Noise Limit (dBm)	Measured Noise (dBm)	Margin (dB)
-78.0	-37.7	-38.0	-0.3
-77.0	-37.7	-38.0	-0.4
-71.0	-37.7	-37.9	-0.2
-65.0	-38.0	-38.1	-0.2
-62.0	-41.0	-41.0	-0.1
-61.0	-42.0	-42.0	-0.1

1850 - 1915 MHz

RSSI (dBm)	Noise Limit (dBm)	Measured Noise (dBm)	Margin (dB)
-33.0	-70.0	-71.1	-1.1
-32.0	-70.0	-71.1	-1.1
-31.0	-70.0	-71.1	-1.1
-29.0	-70.0	-71.1	-1.1
-67.0	-37.0	-41.3	-4.4
-66.0	-37.0	-42.2	-5.3

Uplink Inactivity

Engineer: Greg Corbin

Test Date: 6/19/2017

Test Procedure

The EUT was connected directly to a spectrum analyzer set to operate in the center of the EUT operational uplink and downlink bands. The span was set to 0 Hz with a sweep time of 330 seconds and MAX HOLD operation. The EUT was powered on and the time for the uplink to return to an inactive state was measured using the DELTA MARKER method to ensure that it was less than 300 seconds. The noise level after the return to an inactive state was less than -70 dBm/MHz.

Test Setup

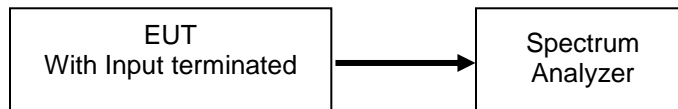

Uplink Inactivity Test Results 300 feet

Frequency Band (MHz)	Measured Time (Seconds)	Limit (Seconds)	Result
698 - 716	278.1	300	Pass
776 - 787	278.1	300	Pass
824 - 849	277.7	300	Pass
1710 - 1755	278.1	300	Pass
1850 - 1915	278.1	300	Pass

Uplink Inactivity Test Results 200 feet

Frequency Band (MHz)	Measured Time (Seconds)	Limit (Seconds)	Result
698 - 716	277.2	300	Pass
776 - 787	277.2	300	Pass
824 - 849	277.8	300	Pass
1710 - 1755	277.2	300	Pass
1850 - 1915	276.6	300	Pass

Uplink Inactivity Test Results 100 feet

Frequency Band (MHz)	Measured Time (Seconds)	Limit (Seconds)	Result
698 - 716	257.4	300	Pass
776 - 787	257.4	300	Pass
824 - 849	277.2	300	Pass
1710 - 1755	278.4	300	Pass
1850 - 1915	278.4	300	Pass

Refer to Annex F for Uplink Inactivity plots

Variable Gain
Engineer: Greg Corbin

Test Date: 6/5/2017

Test Procedure

The EUT was connected to a spectrum analyzer through an attenuator with the losses being input into the spectrum analyzer as a combination of reference level offset and correction factor in order to ensure accurate readings were obtained. The uplink gain in the presence of a downlink signal was measured for each operational uplink band using the detailed procedures from KDB 935210 D03 v04.

The following formula is used for calculating the limits:

$$\text{Variable Gain} = -34 \text{ dB} - \text{RSSI} + \text{MSCL}$$

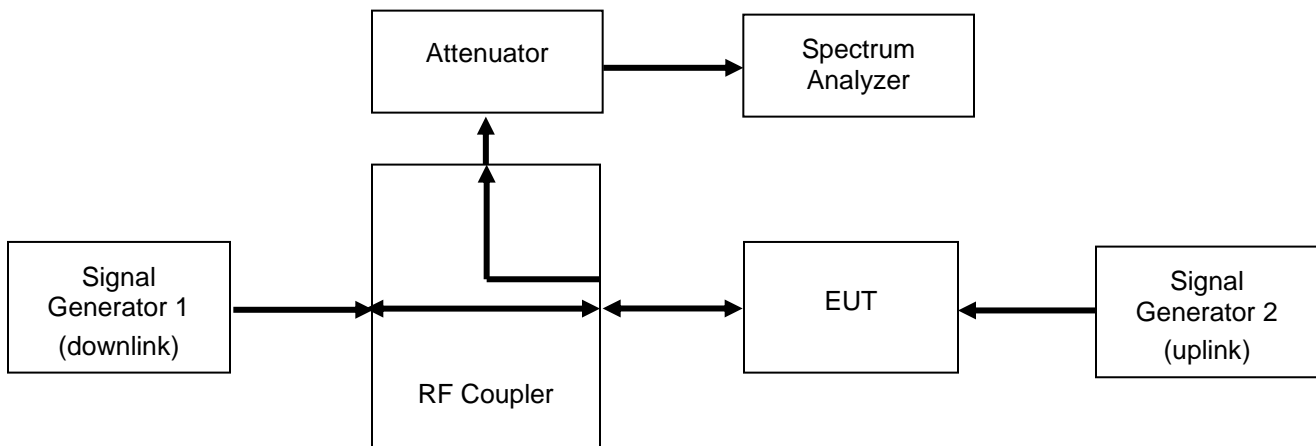
Test Setup

Uplink Variable Gain Test Results for 100 Foot Cable
698 - 716 MHz

RSSI (dBm)	MSCL (dB)	Gain Limit (dBm)	P(in) (dBm)	P(out) (dBm)	Gain (dB)	Margin (dB)
-63.0	38.5	63.5	-49.0	12.6	61.6	-1.9
-62.0	38.5	63.5	-49.0	12.6	61.6	-1.9
-61.0	38.5	63.5	-49.0	12.6	61.6	-1.9
-60.0	38.5	63.5	-49.0	12.6	61.6	-1.9
-59.0	38.5	63.5	-49.0	11.7	60.7	-2.8
-58.0	38.5	62.5	-49.0	10.6	59.6	-2.9

776 - 787 MHz

RSSI (dBm)	MSCL (dB)	Gain Limit (dBm)	P(in) (dBm)	P(out) (dBm)	Gain (dB)	Margin (dB)
-58.0	39.9	63.9	-48.5	12.6	61.1	-2.8
-57.0	39.9	62.9	-48.5	11.4	59.9	-3.0
-56.0	39.9	61.9	-48.5	10.5	59.0	-2.9
-55.0	39.9	60.9	-48.5	9.4	57.9	-3.0
-54.0	39.9	59.9	-48.5	8.4	56.9	-3.0
-53.0	39.9	58.9	-48.5	7.4	55.9	-3.0

824 - 849 MHz

RSSI (dBm)	MSCL (dB)	Gain Limit (dBm)	P(in) (dBm)	P(out) (dBm)	Gain (dB)	Margin (dB)
-57.0	39.9	62.9	-49.9	11.2	61.1	-1.8
-56.0	39.9	61.9	-49.9	9.9	59.8	-2.1
-55.0	39.9	60.9	-49.9	8.9	58.8	-2.1
-54.0	39.9	59.9	-49.9	7.8	57.7	-2.2
-53.0	39.9	58.9	-49.9	7.0	56.9	-2.0
-51.0	39.9	56.9	-49.9	4.8	54.7	-2.2

1710 - 1755 MHz

RSSI (dBm)	MSCL (dB)	Gain Limit (dBm)	P(in) (dBm)	P(out) (dBm)	Gain (dB)	Margin (dB)
-66.0	45.5	71.0	-57.3	11.3	68.6	-2.4
-65.0	45.5	71.0	-57.3	11.3	68.6	-2.4
-64.0	45.5	71.0	-57.3	11.3	68.6	-2.4
-63.0	45.5	71.0	-57.3	11.3	68.6	-2.4
-62.0	45.5	71.0	-57.3	10.3	67.6	-3.4
-61.0	45.5	71.0	-57.3	9.3	66.6	-4.4

1850 - 1915 MHz

RSSI (dBm)	MSCL (dB)	Gain Limit (dBm)	P(in) (dBm)	P(out) (dBm)	Gain (dB)	Margin (dB)
-70.0	44.7	72.0	-56.2	12.7	68.9	-3.1
-69.0	44.7	72.0	-56.2	12.7	68.9	-3.1
-68.0	44.7	72.0	-56.2	12.7	68.9	-3.1
-67.0	44.7	72.0	-56.2	12.1	68.3	-3.7
-66.0	44.7	72.0	-56.2	11.0	67.2	-4.8
-65.0	44.7	72.0	-56.2	9.8	66.0	-6.0

Uplink Variable Gain Test Results for 300 Foot Cable
698 - 716 MHz

RSSI (dBm)	MSCL (dB)	Gain Limit (dBm)	P(in) (dBm)	P(out) (dBm)	Gain (dB)	Margin (dB)
-63.0	38.5	63.5	-49.1	12.5	61.6	-1.9
-62.0	38.5	63.5	-49.1	12.5	61.6	-1.9
-61.0	38.5	63.5	-49.1	12.5	61.6	-1.9
-60.0	38.5	63.5	-49.1	12.5	61.6	-1.9
-59.0	38.5	63.5	-49.1	11.6	60.7	-2.8
-58.0	38.5	62.5	-49.1	10.6	59.7	-2.8

776 - 787 MHz

RSSI (dBm)	MSCL (dB)	Gain Limit (dBm)	P(in) (dBm)	P(out) (dBm)	Gain (dB)	Margin (dB)
-59.0	39.9	64.4	-47.8	13.3	61.1	-3.3
-58.0	39.9	63.9	-47.8	13.1	60.9	-3.0
-57.0	39.9	62.9	-47.8	12.1	59.9	-3.0
-56.0	39.9	61.9	-47.8	10.8	58.6	-3.3
-55.0	39.9	60.9	-47.8	9.8	57.6	-3.3
-54.0	39.9	59.9	-47.8	8.8	56.6	-3.3

824 - 849 MHz

RSSI (dBm)	MSCL (dB)	Gain Limit (dBm)	P(in) (dBm)	P(out) (dBm)	Gain (dB)	Margin (dB)
-58.0	39.9	63.9	-48.8	12.2	61.0	-2.9
-57.0	39.9	62.9	-48.8	11.4	60.2	-2.7
-56.0	39.9	61.9	-48.8	10.3	59.1	-2.8
-55.0	39.9	60.9	-48.8	9.2	58.0	-2.9
-54.0	39.9	59.9	-48.8	8.2	57.0	-2.9
-53.0	39.9	58.9	-48.8	7.4	56.2	-2.7

1710 - 1755 MHz

RSSI (dBm)	MSCL (dB)	Gain Limit (dBm)	P(in) (dBm)	P(out) (dBm)	Gain (dB)	Margin (dB)
-67.0	45.5	71.0	-56.7	11.6	68.3	-2.7
-66.0	45.5	71.0	-56.7	11.6	68.3	-2.7
-65.0	45.5	71.0	-56.7	11.6	68.3	-2.7
-64.0	45.5	71.0	-56.7	11.6	68.3	-2.7
-63.0	45.5	71.0	-56.7	10.7	67.4	-3.6
-62.0	45.5	71.0	-56.7	9.6	66.3	-4.7

1850 - 1915 MHz

RSSI (dBm)	MSCL (dB)	Gain Limit (dBm)	P(in) (dBm)	P(out) (dBm)	Gain (dB)	Margin (dB)
-70.0	44.7	72.0	-55.4	12.8	68.2	-3.8
-69.0	44.7	72.0	-55.4	12.8	68.2	-3.8
-68.0	44.7	72.0	-55.4	12.8	68.2	-3.8
-67.0	44.7	72.0	-55.4	12.3	67.7	-4.3
-66.0	44.7	72.0	-55.4	11.2	66.6	-5.4
-65.0	44.7	72.0	-55.4	9.9	65.3	-6.7

Uplink Gain Timing Test Results for 100 Foot Cable

Frequency Band (MHz)	Measured Timing (Seconds)	Limit (Seconds)	Result
704 - 716	1.29	3.0	Pass
776 - 787	1.04	3.0	Pass
824 - 849	1.04	3.0	Pass
1710 - 1755	0.39	3.0	Pass
1850 - 1915	0.46	3.0	Pass

Uplink Gain Timing Test Results for 300 Foot Cable

Frequency Band (MHz)	Measured Timing (Seconds)	Limit (Seconds)	Result
704 - 716	1.50	3.0	Pass
776 - 787	1.55	3.0	Pass
824 - 849	1.55	3.0	Pass
1710 - 1755	1.23	3.0	Pass
1850 - 1915	1.20	3.0	Pass

Uplink Variable Gain Test Results for 200 Foot Cable

698 - 716 MHz

RSSI (dBm)	MSCL (dB)	Gain Limit (dBm)	P(in) (dBm)	P(out) (dBm)	Gain (dB)	Margin (dB)
-74.0	38.5	63.5	-47.6	12.7	60.3	-3.2
-73.0	38.5	63.5	-47.6	12.7	60.3	-3.2
-72.0	38.5	63.5	-47.6	12.7	60.3	-3.2
-71.0	38.5	63.5	-47.6	12.7	60.3	-3.2
-57.0	38.5	61.5	-47.6	8.1	55.7	-5.8
-56.0	38.5	60.5	-47.6	6.9	54.5	-6.0

776 - 787 MHz

RSSI (dBm)	MSCL (dB)	Gain Limit (dBm)	P(in) (dBm)	P(out) (dBm)	Gain (dB)	Margin (dB)
-90.0	39.9	64.4	-46.2	14.5	60.7	-3.7
-89.0	39.9	64.4	-46.2	14.5	60.7	-3.7
-88.0	39.9	64.4	-46.2	14.5	60.7	-3.7
-87.0	39.9	64.4	-46.2	14.5	60.7	-3.7
-54.0	39.9	59.9	-46.2	8.3	54.5	-5.5
-53.0	39.9	58.9	-46.2	7.1	53.3	-5.6

824 - 849 MHz

RSSI (dBm)	MSCL (dB)	Gain Limit (dBm)	P(in) (dBm)	P(out) (dBm)	Gain (dB)	Margin (dB)
-65.0	39.9	64.9	-47.9	13.2	61.1	-3.8
-64.0	39.9	64.9	-47.9	13.3	61.2	-3.7
-63.0	39.9	64.9	-47.9	13.1	61.0	-3.9
-62.0	39.9	64.9	-47.9	13.2	61.1	-3.8
-52.0	39.9	57.9	-47.9	5.8	53.7	-4.3
-51.0	39.9	56.9	-47.9	5.3	53.2	-3.8

1710 - 1755 MHz

RSSI (dBm)	MSCL (dB)	Gain Limit (dBm)	P(in) (dBm)	P(out) (dBm)	Gain (dB)	Margin (dB)
-68.0	45.5	71.0	-55.5	12.2	67.7	-3.3
-67.0	45.5	71.0	-55.5	12.2	67.7	-3.3
-66.0	45.5	71.0	-55.5	12.2	67.7	-3.3
-65.0	45.5	71.0	-55.5	12.2	67.7	-3.3
-62.0	45.5	71.0	-55.5	8.8	64.3	-6.7
-61.0	45.5	71.0	-55.5	7.9	63.4	-7.6

1850 - 1915 MHz

RSSI (dBm)	MSCL (dB)	Gain Limit (dBm)	P(in) (dBm)	P(out) (dBm)	Gain (dB)	Margin (dB)
-70.0	44.7	72.0	-54.4	13.3	67.7	-4.3
-69.0	44.7	72.0	-54.4	13.1	67.5	-4.5
-68.0	44.7	72.0	-54.4	12.2	66.6	-5.4
-67.0	44.7	72.0	-54.4	11.1	65.5	-6.5
-66.0	44.7	72.0	-54.4	10.1	64.5	-7.5
-65.0	44.7	72.0	-54.4	9.2	63.6	-8.4

Uplink Gain Timing Test Results for 200 Foot Cable

Frequency Band (MHz)	Measured Timing (Seconds)	Limit (Seconds)	Result
704 - 716	1.23	3.0	Pass
776 - 787	0.92	3.0	Pass
824 - 849	1.00	3.0	Pass
1710 - 1755	1.23	3.0	Pass
1850 - 1915	0.97	3.0	Pass

Refer to Annex G for Uplink Gain Timing Plots

Occupied Bandwidth

Engineer: Greg Corbin

Test Date: 6/5/2017

Test Procedure

The EUT was connected to a spectrum analyzer through an attenuator with the losses being input into the spectrum analyzer as a combination of reference level offset and correction factor as required to ensure that accurate readings were obtained. A signal generator was utilized to produce the following signals: GSM, CDMA, and WCDMA. The signal generator was tuned to the center channel of each of the EUT operational uplink and downlink bands with the RF level set at a point just prior to the AGC being in control of the power. For each modulation type, the input and output signal was measured and plotted to ensure that the signals were similar.

Test Setup

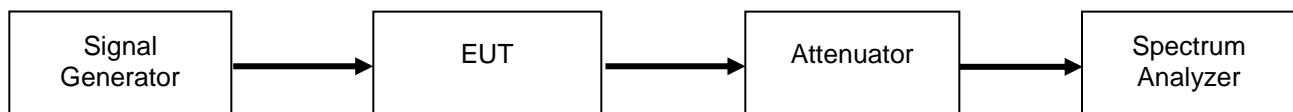

Refer to Annex H for Occupied Bandwidth plots

Anti-Oscillation

Engineer: Greg Corbin

Test Date: 6/16/2017

Test Procedure

The EUT was connected to a spectrum analyzer set for zero span mode. The EUT uplink and downlink were loop backed to each other through a selectable band pass filter and variable attenuator. The EUT uplink and downlink were tested to ensure that the presence of oscillation was detected and that the EUT output turned off within 300 mS for the Uplink and 1 second for the Downlink and remained off for 1 minute. The time was extended to capture how many times the unit attempted to restart.

Notes:

1. After detecting the 1st oscillation the EUT mitigates the oscillation by reducing the gain so there are no restarts or # of retries.
2. Anti-Oscillation and Oscillation Mitigation tests are not impacted by the 100 ft. vs 300 ft. cable lengths, so these test were only performed 1 time for both cable lengths. The test data was recorded with a 300 ft. cable length.

Test Setup

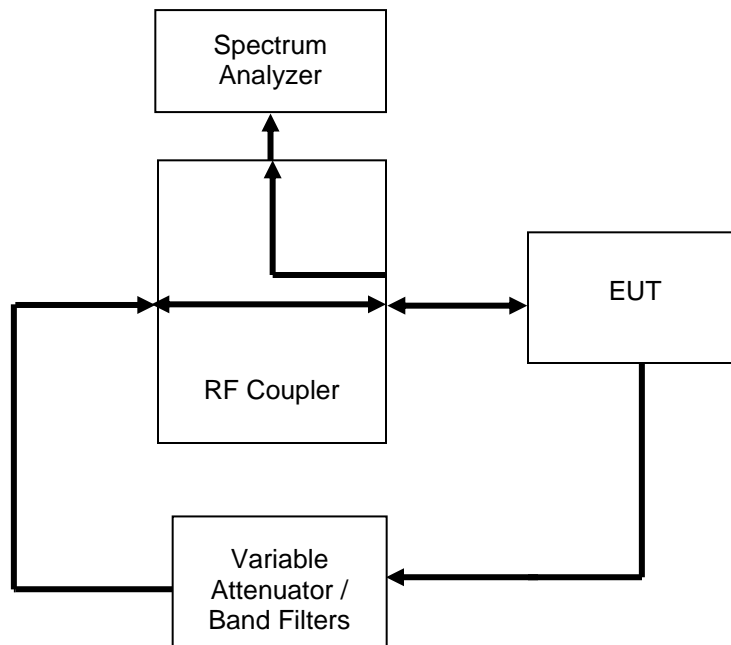

Results for 300 Foot Cable

Uplink Detection Time Test Results

Frequency Band (MHz)	Measured Time (mS)	Limit (mS)	Result
698 - 716	100	300	Pass
776 - 787	125	300	Pass
824 - 849	125	300	Pass
1710 - 1755	125	300	Pass
1850 - 1915	125	300	Pass

Downlink Detection Time Test Results

Frequency Band (MHz)	Measured Time (mS)	Limit (mS)	Result
728 - 746	150	1000	Pass
746 - 757	112.5	1000	Pass
869 - 894	112.5	1000	Pass
1930 - 1995	125	1000	Pass
2110 - 2155	225	1000	Pass

Note:

After detecting the 1st oscillation the EUT mitigates the oscillation by reducing the gain so there are no restarts or number of retries.

Uplink Restart Time Test Results

Frequency Band (MHz)	Measured Time (S)	Limit (S)	Result
698 - 716	No restarts	≥60	Pass
776 - 787	No restarts	≥60	Pass
824 - 849	No restarts	≥60	Pass
1710 - 1755	No restarts	≥60	Pass
1850 - 1915	No restarts	≥60	Pass

Downlink Restart Time Test Results

Frequency Band (MHz)	Measured Time (S)	Limit (S)	Result
728 - 746	No restarts	≥60	Pass
746 - 757	No restarts	≥60	Pass
869 - 894	No restarts	≥60	Pass
1930 - 1995	No restarts	≥60	Pass
2110 - 2155	No restarts	≥60	Pass

Note:

After detecting the 1st oscillation the EUT mitigates the oscillation by reducing the gain so there are no restarts or number of retries.

Uplink Restart Count Test Results

Frequency Band (MHz)	Restarts	Limit	Result
698 - 716	0	≤5	Pass
776 - 787	0	≤5	Pass
824 - 849	0	≤5	Pass
1710 - 1755	0	≤5	Pass
1850 - 1915	0	≤5	Pass

Downlink Restart Count Test Results

Frequency Band (MHz)	Restarts	Limit	Result
728 - 746	0	≤5	Pass
746 - 757	0	≤5	Pass
869 - 894	0	≤5	Pass
1930 - 1995	0	≤5	Pass
2110 - 2155	0	≤5	Pass

Results for 100 Foot Cable

Uplink Detection Time Test Results

Frequency Band (MHz)	Measured Time (mS)	Limit (mS)	Result
698 - 716	116.7	300	Pass
776 - 787	66.67	300	Pass
824 - 849	91.67	300	Pass
1710 - 1755	125	300	Pass
1850 - 1915	125	300	Pass

Downlink Detection Time Test Results

Frequency Band (MHz)	Measured Time (mS)	Limit (mS)	Result
728 - 746	100	1000	Pass
746 - 757	75	1000	Pass
869 - 894	108.3	1000	Pass
1930 - 1995	66.67	1000	Pass
2110 - 2155	91.67	1000	Pass

Note:

After detecting the 1st oscillation the EUT mitigates the oscillation by reducing the gain so there are no restarts or number of retries.

Uplink Restart Time Test Results

Frequency Band (MHz)	Measured Time (S)	Limit (S)	Result
698 - 716	No restarts	≥60	Pass
776 - 787	No restarts	≥60	Pass
824 - 849	No restarts	≥60	Pass
1710 - 1755	No restarts	≥60	Pass
1850 - 1915	No restarts	≥60	Pass

Downlink Restart Time Test Results

Frequency Band (MHz)	Measured Time (S)	Limit (S)	Result
728 - 746	No restarts	≥60	Pass
746 - 757	No restarts	≥60	Pass
869 - 894	No restarts	≥60	Pass
1930 - 1995	No restarts	≥60	Pass
2110 - 2155	No restarts	≥60	Pass

Note:

After detecting the 1st oscillation the EUT mitigates the oscillation by reducing the gain so there are no restarts or number of retries.

Uplink Restart Count Test Results

Frequency Band (MHz)	Restarts	Limit	Result
698 - 716	0	≤5	Pass
776 - 787	0	≤5	Pass
824 - 849	0	≤5	Pass
1710 - 1755	0	≤5	Pass
1850 - 1915	0	≤5	Pass

Downlink Restart Count Test Results

Frequency Band (MHz)	Restarts	Limit	Result
728 - 746	0	≤5	Pass
746 - 757	0	≤5	Pass
869 - 894	0	≤5	Pass
1930 - 1995	0	≤5	Pass
2110 - 2155	0	≤5	Pass

Results for 200 Foot Cable

Uplink Detection Time Test Results

Frequency Band (MHz)	Measured Time (mS)	Limit (mS)	Result
698 - 716	158.3	300	Pass
776 - 787	191.7	300	Pass
824 - 849	233.3	300	Pass
1710 - 1755	216.7	300	Pass
1850 - 1915	216.7	300	Pass

Downlink Detection Time Test Results

Frequency Band (MHz)	Measured Time (mS)	Limit (mS)	Result
728 - 746	183.3	1000	Pass
746 - 757	266.7	1000	Pass
869 - 894	91.67	1000	Pass
1930 - 1995	108.3	1000	Pass
2110 - 2155	91.67	1000	Pass

Note:

1. After detecting the 1st oscillation the EUT mitigates the oscillation by reducing the gain so there are no restarts or number of retries.

Uplink Restart Time Test Results

Frequency Band (MHz)	Measured Time (S)	Limit (S)	Result
698 - 716	No restarts	≥60	Pass
776 - 787	No restarts	≥60	Pass
824 - 849	No restarts	≥60	Pass
1710 - 1755	No restarts	≥60	Pass
1850 - 1915	No restarts	≥60	Pass

Downlink Restart Time Test Results

Frequency Band (MHz)	Measured Time (S)	Limit (S)	Result
728 - 746	No restarts	≥60	Pass
746 - 757	No restarts	≥60	Pass
869 - 894	No restarts	≥60	Pass
1930 - 1995	No restarts	≥60	Pass
2110 - 2155	No restarts	≥60	Pass

Note:

1. After detecting the 1st oscillation the EUT mitigates the oscillation by reducing the gain so there are no restarts or number of retries.

Uplink Restart Count Test Results

Frequency Band (MHz)	Restarts	Limit	Result
698 - 716	0	≤5	Pass
776 - 787	0	≤5	Pass
824 - 849	0	≤5	Pass
1710 - 1755	0	≤5	Pass
1850 - 1915	0	≤5	Pass

Downlink Restart Count Test Results

Frequency Band (MHz)	Restarts	Limit	Result
728 - 746	0	≤5	Pass
746 - 757	0	≤5	Pass
869 - 894	0	≤5	Pass
1930 - 1995	0	≤5	Pass
2110 - 2155	0	≤5	Pass

Refer to Annex I for Anti-Oscillation plots

Oscillation Mitigation

Engineer: Greg Corbin

Test Date: 2/2/2017

Test Procedure

The EUT was connected as shown per KDB 935210 D03 v04. The EUT was verified to shut down in the presence of an oscillation.

The total attenuation from output to input was set +5 dB higher than the gain for the band being tested.

For EUT's that do not shutdown, the peak oscillation was measured and the variable attenuator was reduced in 1 dB increments until the booster shuts off.

The frequency and amplitude of the highest oscillation and the lowest level in the valley next to the oscillation was recorded for each 1 dB step as required per the KDB.

For oscillations that exceeded the 12 dB limit, the time required for the booster to mitigate the oscillation to less than 12 dB was recorded.

If the booster mitigated the oscillation within the 300 second time limit, the time required to mitigate the oscillation was recorded along with the final level of the oscillation after mitigation.

Notes:

1. In all cases the booster mitigated the oscillation to less than 12 dB before the 300 second limit.
2. Oscillation Mitigation tests are not impacted by the 100 ft. vs 300 ft. cable lengths, so these tests were only performed 1 time for both cable lengths. The test data was recorded with a 300 ft. cable length.

Test Setup

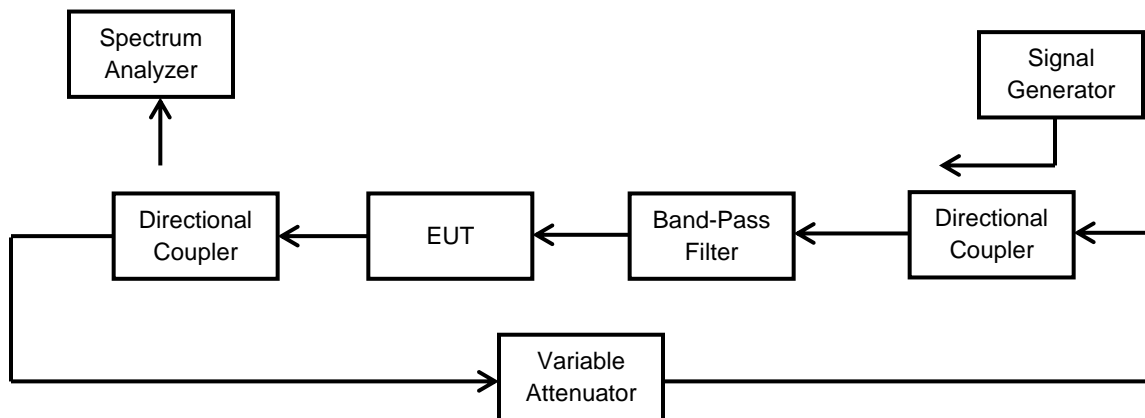

Results From 300 Foot Cable Length Test

Uplink Oscillation Mitigation Test Data

Oscillation Mitigation - Uplink									
Band	698 – 716 MHz								
Test Signal Type	CDMA								
Variable Attenuator Setting	Oscillations		Lowest Output Power Level		Margin	Limit	Time to Mitigate Oscillation	Mitigation Time Limit	Pass / Fail
	Freq.	Level	Freq.	Level					
dB	MHz	dBm	MHz	dBm	dB	dB	sec	sec	
+5	710.31	-49	709.59	-66.5	17.5	<12	150	< 300	Pass
+4	710.31	-45	709.59	-66	21	<12	105	< 300	Pass
+3	710.31	-38	709.59	-67	29	<12	156	< 300	Pass
+2	'EUT mitigates oscillation immediately, by reducing the gain but does not shut down								Pass

Oscillation Mitigation - Uplink									
Band	776 – 787 MHz								
Test Signal Type	CDMA								
Variable Attenuator Setting	Oscillations		Lowest Output Power Level		Margin	Limit	Time to Mitigate Oscillation	Mitigation Time Limit	Pass / Fail
	Freq.	Level	Freq.	Level					
dB	MHz	dBm	MHz	dBm	dB	dB	sec	sec	
+5	779.68	-49	779.16	-65	16	<12	175	< 300	Pass
+4	779.68	-46	779.16	-65	19	<12	141	< 300	Pass
+3	779.68	-38	779.16	-66	28	<12	145	< 300	Pass
+2	'EUT mitigates oscillation immediately, by reducing the gain but does not shut down								Pass

Oscillation Mitigation - Uplink									
Band	824 - 849 MHz								
Test Signal Type	CDMA								
Variable Attenuator Setting	Oscillations		Lowest Output Power Level		Margin	Limit	Time to Mitigate Oscillation	Mitigation Time Limit	Pass / Fail
	Freq.	Level	Freq.	Level					
dB	MHz	dBm	MHz	dBm	dB	dB	sec	sec	
+5	833.78	-53.7	834.47	-66.7	13	<12	165	< 300	Pass
+4	833.78	-52.1	834.47	-66.7	14.6	<12	164	< 300	Pass
+3	833.78	-50	834.47	-67	17	<12	164	< 300	Pass
+2	833.78	-45	834.47	-67.5	22.5	<12	160	< 300	Pass
+1	833.78	-35.5	834.47	-67.7	32.2	<12	162	< 300	Pass
+0	'EUT mitigates oscillation immediately, by reducing the gain but does not shut down								Pass

Oscillation Mitigation - Uplink									
Band	1710 - 1755 MHz								
Test Signal Type	CDMA								
Variable Attenuator Setting	Oscillations		Lowest Output Power Level		Margin	Limit	Time to Mitigate Oscillation	Mitigation Time Limit	Pass / Fail
	Freq.	Level	Freq.	Level					
dB	MHz	dBm	MHz	dBm	dB	dB	sec	sec	
+5	1752.93	-44.7	1751.99	-57.9	13.2	<12	167	< 300	Pass
+4	1752.93	-42.7	1751.99	-58	15.3	<12	164	< 300	Pass
+3	1752.93	-40.1	1751.99	-58.9	18.8	<12	151	< 300	Pass
+2	1752.93	-32.5	1751.99	-58.9	26.4	<12	136	< 300	Pass
+1	1752.93	-1	1751.99	-59.2	58.2	<12	167	< 300	Pass
+0	'EUT mitigates oscillation immediately, by reducing the gain but does not shut down								Pass

Oscillation Mitigation - Uplink									
Band	1850 - 1915 MHz								
Test Signal Type	CDMA								
Variable Attenuator Setting	Oscillations		Lowest Output Power Level		Margin	Limit	Time to Mitigate Oscillation	Mitigation Time Limit	Pass / Fail
	Freq.	Level	Freq.	Level					
dB	MHz	dBm	MHz	dBm	dB	dB	sec	sec	
+5	1879.53	-47.3	1878.69	-59.6	12.3	<12	164	< 300	Pass
+4	1879.53	-45.2	1878.69	-60.2	15	<12	167	< 300	Pass
+3	1879.53	-42.6	1878.69	-60.8	18.2	<12	169	< 300	Pass
+2	1879.53	-39.6	1878.69	-61.5	21.9	<12	162	< 300	Pass
+1	1879.53	-27.1	1878.69	-61.5	34.4	<12	163	< 300	Pass
+0	'EUT mitigates oscillation immediately, by reducing the gain but does not shut down								Pass

Downlink Oscillation Mitigation Test Data

Oscillation Mitigation - Downlink									
Band	728 - 746 MHz								
Test Signal Type	CDMA								
Variable Attenuator Setting	Oscillations		Lowest Output Power Level		Margin	Limit	Time to Mitigate Oscillation	Mitigation Time Limit	Pass / Fail
	Freq.	Level	Freq.	Level					
dB	MHz	dBm	MHz	dBm	dB	dB	sec	sec	
+5	737.33	-51.1	738.09	-65.3	14.2	<12	169	< 300	Pass
+4	737.33	-48.2	738.09	-65	16.8	<12	166	< 300	Pass
+3	737.33	-44.2	738.09	-65.9	21.7	<12	164	< 300	Pass
+2	737.33	-36.7	738.09	-66.2	29.5	<12	165	< 300	Pass
+1	'EUT mitigates oscillation immediately, by reducing the gain but does not shut down								Pass

Oscillation Mitigation - Downlink									
Band	746 - 757 MHz								
Test Signal Type	CDMA								
Variable Attenuator Setting	Oscillations		Lowest Output Power Level		Margin	Limit	Time to Mitigate Oscillation	Mitigation Time Limit	Pass / Fail
	Freq.	Level	Freq.	Level					
dB	MHz	dBm	MHz	dBm	dB	dB	sec	sec	
+5	746.41	-53.1	745.74	-65.4	12.3	<12	164	< 300	Pass
+4	746.41	-52.4	745.74	-65.7	13.3	<12	166	< 300	Pass
+3	746.41	-49.8	745.74	-66.1	16.3	<12	166	< 300	Pass
+2	746.41	-47.1	745.74	-66.2	19.1	<12	164	< 300	Pass
+1	'EUT mitigates oscillation immediately, by reducing the gain but does not shut down								Pass

Oscillation Mitigation – Downlink									
Band	869 - 894 MHz								
Test Signal Type	CDMA								
Variable Attenuator Setting	Oscillations		Lowest Output Power Level		Margin	Limit	Time to Mitigate Oscillation	Mitigation Time Limit	Pass / Fail
	Freq.	Level	Freq.	Level					
dB	MHz	dBm	MHz	dBm	dB	dB	sec	sec	
+5	879.51	-52	880.36	-64.2	879.51	<12	165	< 300	Pass
+4	879.51	-50.4	880.36	-64.2	879.51	<12	165	< 300	Pass
+3	879.51	-47.9	880.36	-65.1	879.51	<12	161	< 300	Pass
+2	879.51	-45.1	880.36	-65.2	879.51	<12	165	< 300	Pass
+1	879.51	-36.3	880.36	-66.4	879.51	<12	-63	< 300	Pass
+0	'EUT mitigates oscillation immediately, by reducing the gain but does not shut down								Pass

Oscillation Mitigation - Downlink									
Band	1930 - 1995 MHz								
Test Signal Type	CDMA								
Variable Attenuator Setting	Oscillations		Lowest Output Power Level		Margin	Limit	Time to Mitigate Oscillation	Mitigation Time Limit	Pass / Fail
	Freq.	Level	Freq.	Level					
dB	MHz	dBm	MHz	dBm	dB	dB	sec	sec	
+5	1970.31	-48.5	1969.3	-58.7	10.2	<12	N/A	< 300	Pass
+4	1970.31	-47.2	1969.3	-58.5	11.3	<12	N/A	< 300	Pass
+3	1970.31	-45.4	1969.3	-58.9	13.5	<12	168	< 300	Pass
+2	1970.31	-43.6	1969.3	-59.4	15.8	<12	167	< 300	Pass
+1	1970.31	-41.1	1969.3	-60.1	19	<12	165	< 300	Pass
+0	1970.31	-34.4	1969.3	-60	25.6	<12	162	< 300	Pass
-1	'EUT mitigates oscillation immediately, by reducing the gain but does not shut down								Pass

Oscillation Mitigation - Uplink									
Band	2110 - 2155 MHz								
Test Signal Type	CDMA								
Variable Attenuator Setting	Oscillations		Lowest Output Power Level		Margin	Limit	Time to Mitigate Oscillation	Mitigation Time Limit	Pass / Fail
	Freq.	Level	Freq.	Level					
dB	MHz	dBm	MHz	dBm	dB	dB	sec	sec	
+5	2126.8	-51.2	2125.81	-60.4	9.2	<12	N/A	< 300	Pass
+4	2126.8	-50.1	2125.81	-60.1	10	<12	N/A	< 300	Pass
+3	2126.8	-48.2	2125.81	-61.1	12.9	<12	166	< 300	Pass
+2	2126.8	-47.2	2125.81	-61.4	14.2	<12	166	< 300	Pass
+1	2126.8	-44.2	2125.81	-61.5	17.3	<12	162	< 300	Pass
+0	2126.8	-38.5	2125.81	-62.1	23.6	<12	167	< 300	Pass
-1	'EUT mitigates oscillation immediately, by reducing the gain but does not shut down								Pass

Results From 100 Foot Cable Length Test

Uplink Oscillation Mitigation Test Data

Oscillation Mitigation - Uplink									
Band	698 – 716 MHz								
Test Signal Type	CDMA								
Variable Attenuator Setting	Oscillations		Lowest Output Power Level		Margin	Limit	Time to Mitigate Oscillation	Mitigation Time Limit	Pass / Fail
	Freq.	Level	Freq.	Level					
dB	MHz	dBm	MHz	dBm	dB	dB	sec	sec	
+5	710.46	-57	709.5	-75.6	18.6	<12	135	< 300	Pass
+4	710.46	-52.1	709.5	-76	23.9	<12	135	< 300	Pass
+3	710.46	-27.5	709.5	-76.8	49.3	<12	168	< 300	Pass
+2	'EUT mitigates oscillation immediately, by reducing the gain but does not shut down								Pass

Oscillation Mitigation - Uplink									
Band	776 – 787 MHz								
Test Signal Type	CDMA								
Variable Attenuator Setting	Oscillations		Lowest Output Power Level		Margin	Limit	Time to Mitigate Oscillation	Mitigation Time Limit	Pass / Fail
	Freq.	Level	Freq.	Level					
dB	MHz	dBm	MHz	dBm	dB	dB	sec	sec	
+5	788.3	-56.2	779.5	-74.3	18.1	<12	168	< 300	Pass
+4	788.3	-52.8	779.5	-74.5	21.7	<12	167	< 300	Pass
+3	788.3	-45.6	779.5	-74.3	28.7	<12	167	< 300	Pass
+2	'EUT mitigates oscillation immediately, by reducing the gain but does not shut down								Pass

Oscillation Mitigation - Uplink									
Band	824 - 849 MHz								
Test Signal Type	CDMA								
Variable Attenuator Setting	Oscillations		Lowest Output Power Level		Margin	Limit	Time to Mitigate Oscillation	Mitigation Time Limit	Pass / Fail
	Freq.	Level	Freq.	Level					
dB	MHz	dBm	MHz	dBm	dB	dB	sec	sec	
+5	834.2	-59.6	835.3	-74.8	15.2	<12	140	< 300	Pass
+4	834.2	-56.9	835.3	-75.4	18.5	<12	165	< 300	Pass
+3	834.2	-50.9	835.3	-75.5	24.6	<12	155	< 300	Pass
+2	834.2	-32.9	835.3	-76.7	43.8	<12	139	< 300	Pass
+1	'EUT mitigates oscillation immediately, by reducing the gain but does not shut down								Pass

Oscillation Mitigation - Uplink									
Band	1710 - 1755 MHz								
Test Signal Type	CDMA								
Variable Attenuator Setting	Oscillations		Lowest Output Power Level		Margin	Limit	Time to Mitigate Oscillation	Mitigation Time Limit	Pass / Fail
	Freq.	Level	Freq.	Level					
dB	MHz	dBm	MHz	dBm	dB	dB	sec	sec	
+5	1753	-49.2	1754.5	-67.2	18	<12	161	< 300	Pass
+4	1753	-48.9	1754.5	-67.5	18.6	<12	168	< 300	Pass
+3	1753	-46.7	1754.5	-67.5	20.8	<12	169	< 300	Pass
+2	'EUT mitigates oscillation immediately, by reducing the gain but does not shut down								Pass

Oscillation Mitigation - Uplink									
Band	1850 - 1915 MHz								
Test Signal Type	CDMA								
Variable Attenuator Setting	Oscillations		Lowest Output Power Level		Margin	Limit	Time to Mitigate Oscillation	Mitigation Time Limit	Pass / Fail
	Freq.	Level	Freq.	Level					
dB	MHz	dBm	MHz	dBm	dB	dB	sec	sec	
+5	1882.3	-55.5	1883.9	-66.1	10.6	<12	N/A	N/A	Pass
+4	1882.3	-55	1883.9	-67.6	12.6	<12	127	< 300	Pass
+3	1882.3	-51.6	1883.9	-66.9	15.3	<12	166	< 300	Pass
+2	1882.3	-49.1	1883.9	-68.1	19	<12	172	< 300	Pass
+1	1882.3	-51.9	1883.9	-67.4	15.5	<12	170	< 300	Pass
+0	1882.3	-49.6	1883.9	-67.3	17.7	<12	165	< 300	Pass
-1	1882.3	-43.9	1883.9	-68.2	24.3	<12	167	< 300	Pass
-2	'EUT mitigates oscillation immediately, by reducing the gain but does not shut down								Pass

Downlink Oscillation Mitigation Test Data

Oscillation Mitigation - Downlink									
Band	728 - 746 MHz								
Test Signal Type	CDMA								
Variable Attenuator Setting	Oscillations		Lowest Output Power Level		Margin	Limit	Time to Mitigate Oscillation	Mitigation Time Limit	Pass / Fail
	Freq.	Level	Freq.	Level					
dB	MHz	dBm	MHz	dBm	dB	dB	sec	sec	
+5	738.02	-50.7	736.85	-65.2	14.5	<12	162	< 300	Pass
+4	738.02	-49.1	736.85	-66.2	17.1	<12	161	< 300	Pass
+3	738.02	-45.1	736.85	-66.1	21	<12	165	< 300	Pass
+2	738.02	-36.1	736.85	-66.8	30.7	<12	161	< 300	Pass
+1	'EUT mitigates oscillation immediately, by reducing the gain but does not shut down								Pass

Oscillation Mitigation - Downlink									
Band	746 - 757 MHz								
Test Signal Type	CDMA								
Variable Attenuator Setting	Oscillations		Lowest Output Power Level		Margin	Limit	Time to Mitigate Oscillation	Mitigation Time Limit	Pass / Fail
	Freq.	Level	Freq.	Level					
dB	MHz	dBm	MHz	dBm	dB	dB	sec	sec	
+5	747.75	-61	746.55	-73.4	12.4	<12	130	< 300	Pass
+4	747.75	-60.2	746.55	-74.3	14.1	<12	135	< 300	Pass
+3	747.75	-58.1	746.55	-74.3	16.2	<12	146	< 300	Pass
+2	747.75	-47.6	746.55	-73.9	26.3	<12	165	< 300	Pass
+1	'EUT mitigates oscillation immediately, by reducing the gain but does not shut down								Pass

Oscillation Mitigation - Downlink									
Band	869 - 894 MHz								
Test Signal Type	CDMA								
Variable Attenuator Setting	Oscillations		Lowest Output Power Level		Margin	Limit	Time to Mitigate Oscillation	Mitigation Time Limit	Pass / Fail
	Freq.	Level	Freq.	Level					
dB	MHz	dBm	MHz	dBm	dB	dB	sec	sec	
+5	878.8	-59.1	876.9	-70.7	11.63	<12	N/A	N/A	Pass
+4	878.8	-57.1	876.9	-71.5	14.4	<12	165	< 300	Pass
+3	878.8	-55.4	876.9	-71.8	16.4	<12	155	< 300	Pass
+2	878.8	-52.4	876.9	-72.2	19.8	<12	154	< 300	Pass
+1	878.8	-46.3	876.9	-72.8	26.5	<12	165	< 300	Pass
+0	'EUT mitigates oscillation immediately, by reducing the gain but does not shut down								Pass

Oscillation Mitigation - Downlink									
Band	1930 - 1995 MHz								
Test Signal Type	CDMA								
Variable Attenuator Setting	Oscillations		Lowest Output Power Level		Margin	Limit	Time to Mitigate Oscillation	Mitigation Time Limit	Pass / Fail
	Freq.	Level	Freq.	Level					
dB	MHz	dBm	MHz	dBm	dB	dB	sec	sec	
+5	1959.5	-53.4	1957.8	-64.5	11.1	<12	N/A	< 300	Pass
+4	1959.5	-51.4	1957.8	-65.7	14.3	<12	178	< 300	Pass
+3	1959.5	-48.1	1957.8	-66.1	18	<12	172	< 300	Pass
+2	1959.5	-46.9	1957.8	-66.2	19.3	<12	171	< 300	Pass
+1	1959.5	-37.2	1957.8	-66.9	29.7	<12	163	< 300	Pass
+0	'EUT mitigates oscillation immediately, by reducing the gain but does not shut down								Pass

Oscillation Mitigation - Uplink									
Band	2110 - 2155 MHz								
Test Signal Type	CDMA								
Variable Attenuator Setting	Oscillations		Lowest Output Power Level		Margin	Limit	Time to Mitigate Oscillation	Mitigation Time Limit	Pass / Fail
	Freq.	Level	Freq.	Level					
dB	MHz	dBm	MHz	dBm	dB	dB	sec	sec	
+5	2131.82	-51.1	2132.77	-59.4	8.3	<12	N/A	N/A	Pass
+4	2131.82	-51	2132.77	-59.8	8.8	<12	N/A	< 300	Pass
+3	2131.82	-49.4	2132.77	-59.4	10	<12	N/A	< 300	Pass
+2	2131.82	-45.2	2132.77	-59.6	14.4	<12	168	< 300	Pass
+1	2131.82	-43.2	2132.77	-60.1	16.9	<12	165	< 300	Pass
+0	2131.82	-38.2	2132.77	-60.9	22.7	<12	169	< 300	Pass
-1	2131.82	-34.1	2132.77	-61.2	27.1	<12	166	< 300	Pass
-2	'EUT mitigates oscillation immediately, by reducing the gain but does not shut down								Pass

Results From 200 Foot Cable Length Tests

Uplink Oscillation Mitigation Test Data

Oscillation Mitigation - Uplink									
Band	698 – 716 MHz								
Test Signal Type	CDMA								
Variable Attenuator Setting	Oscillations		Lowest Output Power Level		Margin	Limit	Time to Mitigate Oscillation	Mitigation Time Limit	Pass / Fail
	Freq.	Level	Freq.	Level					
dB	MHz	dBm	MHz	dBm	dB	dB	sec	sec	
+5	711.024	-54.7	710.242	-68.2	13.5	<12	150	< 300	Pass
+4	711.024	-52.4	710.242	-67.9	15.56	<12	153	< 300	Pass
+3	711.024	-49.3	710.242	-68.9	19.52	<12	175	< 300	Pass
+2	711.024	-44.5	710.242	-69.1	24.6	<12	171	< 300	Pass
+1	711.024	-1.28	710.242	-69.1	67.82	<12	157	< 300	Pass
+0	'EUT mitigates oscillation immediately, by reducing the gain but does not shut down								Pass

Oscillation Mitigation - Uplink									
Band	776 – 787 MHz								
Test Signal Type	CDMA								
Variable Attenuator Setting	Oscillations		Lowest Output Power Level		Margin	Limit	Time to Mitigate Oscillation	Mitigation Time Limit	Pass / Fail
	Freq.	Level	Freq.	Level					
dB	MHz	dBm	MHz	dBm	dB	dB	sec	sec	
+5	779.822	-54.1	779.01	-67.1	12.97	<12	230	< 300	Pass
+4	779.822	-53.1	779.01	-67.5	14.38	<12	177	< 300	Pass
+3	779.822	-49.9	779.01	-68.4	18.5	<12	175	< 300	Pass
+2	779.822	-46.7	779.01	-68.2	21.5	<12	159	< 300	Pass
+1	'EUT mitigates oscillation immediately, by reducing the gain but does not shut down								Pass

Oscillation Mitigation - Uplink									
Band	824 - 849 MHz								
Test Signal Type	CDMA								
Variable Attenuator Setting	Oscillations		Lowest Output Power Level		Margin	Limit	Time to Mitigate Oscillation	Mitigation Time Limit	Pass / Fail
	Freq.	Level	Freq.	Level					
dB	MHz	dBm	MHz	dBm	dB	dB	sec	sec	
+5	833.61	-57.5	832.737	-68.1	10.56	<12	N/A	N/A	Pass
+4	833.61	-56.9	832.737	-67.7	10.8	<12	N/a	N/A	Pass
+3	833.61	-55.4	832.737	-68.3	12.9	<12	155	< 300	Pass
+2	833.61	-53.8	832.737	-68.8	14.95	<12	166	< 300	Pass
+1	833.61	-44.5	832.737	-68.7	24.17	<12	159	< 300	Pass
+0	833.61	-32.1	832.737	-69	36.9	<12	166	< 300	Pass
-1	'EUT mitigates oscillation immediately, by reducing the gain but does not shut down								Pass

Oscillation Mitigation - Uplink									
Band	1710 - 1755 MHz								
Test Signal Type	CDMA								
Variable Attenuator Setting	Oscillations		Lowest Output Power Level		Margin	Limit	Time to Mitigate Oscillation	Mitigation Time Limit	Pass / Fail
	Freq.	Level	Freq.	Level					
dB	MHz	dBm	MHz	dBm	dB	dB	sec	sec	
+5	1753.47	-48	1752.2	-59.1	11.1	<12	N/A	N/A	Pass
+4	1753.47	-46.2	1752.2	-59.6	13.4	<12	172	< 300	Pass
+3	1753.47	-39.7	1752.2	-59.1	19.4	<12	153	< 300	Pass
+2	1753.47	-32.9	1752.2	-59.8	26.9	<12	163	< 300	Pass
+1	'EUT mitigates oscillation immediately, by reducing the gain but does not shut down								Pass

Oscillation Mitigation - Uplink									
Band	1850 - 1915 MHz								
Test Signal Type	CDMA								
Variable Attenuator Setting	Oscillations		Lowest Output Power Level		Margin	Limit	Time to Mitigate Oscillation	Mitigation Time Limit	Pass / Fail
	Freq.	Level	Freq.	Level					
dB	MHz	dBm	MHz	dBm	dB	dB	sec	sec	
+5	1862.05	-50.2	1860.89	-59.5	9.3	<12	N/A	N/A	Pass
+4	1862.05	-48.5	1860.89	-59.6	11.1	<12	N/A	N/A	Pass
+3	1862.05	-47.2	1860.89	-60.3	13.1	<12	133	< 300	Pass
+2	1862.05	-44.8	1860.89	-60.7	15.9	<12	156	< 300	Pass
+1	1862.05	-41.5	1860.89	-60.9	19.4	<12	159	< 300	Pass
+0	1862.05	-37.1	1860.89	-61.6	24.5	<12	168	< 300	Pass
-1	'EUT mitigates oscillation immediately, by reducing the gain but does not shut down								Pass

Downlink Oscillation Mitigation Test Data

Oscillation Mitigation - Downlink									
Band	728 - 746 MHz								
Test Signal Type	CDMA								
Variable Attenuator Setting	Oscillations		Lowest Output Power Level		Margin	Limit	Time to Mitigate Oscillation	Mitigation Time Limit	Pass / Fail
	Freq.	Level	Freq.	Level					
dB	MHz	dBm	MHz	dBm	dB	dB	sec	sec	
+5	737.024	-53.5	736.113	-66.9	13.4	<12	165	< 300	Pass
+4	737.024	-51.9	736.113	-67.2	15.23	<12	178	< 300	Pass
+3	737.024	-49.2	736.113	-67.7	18.5	<12	161	< 300	Pass
+2	737.024	-44.2	736.113	-68.5	24.3	<12	164	< 300	Pass
+1	737.024	-28.2	736.113	-68.8	40.6	<12	165	< 300	Pass
+0	'EUT mitigates oscillation immediately, by reducing the gain but does not shut down								Pass

Oscillation Mitigation - Downlink									
Band	746 - 757 MHz								
Test Signal Type	CDMA								
Variable Attenuator Setting	Oscillations		Lowest Output Power Level		Margin	Limit	Time to Mitigate Oscillation	Mitigation Time Limit	Pass / Fail
	Freq.	Level	Freq.	Level					
dB	MHz	dBm	MHz	dBm	dB	dB	sec	sec	
+5	747.23	-53.2	746.31	-66.7	13.5	<12	111	< 300	Pass
+4	747.23	-51.4	746.31	-66.8	15.4	<12	113	< 300	Pass
+3	747.23	-48.7	746.31	-67.7	19	<12	157	< 300	Pass
+2	747.23	-43.2	746.31	-68.1	24.9	<12	168	< 300	Pass
+1	'EUT mitigates oscillation immediately, by reducing the gain but does not shut down								Pass

Oscillation Mitigation – Downlink									
Band	869 - 894 MHz								
Test Signal Type	CDMA								
Variable Attenuator Setting	Oscillations		Lowest Output Power Level		Margin	Limit	Time to Mitigate Oscillation	Mitigation Time Limit	Pass / Fail
	Freq.	Level	Freq.	Level					
dB	MHz	dBm	MHz	dBm	dB	dB	sec	sec	
+5	876.87	-55.9	875.96	-64.3	8.4	<12	N/A	N/A	Pass
+4	876.87	-54.7	875.96	-64.2	9.5	<12	N/A	N/A	Pass
+3	876.87	-53.4	875.96	-64.5	11.1	<12	N/A	N/A	Pass
+2	876.87	-51.3	875.96	-65.1	13.8	<12	165	< 300	Pass
+1	876.87	-49.7	875.96	-65.5	15.8	<12	-63	< 300	Pass
+0	876.87	-47.5	875.96	-65.7	18.2	<12	165	< 300	Pass
-1	876.87	-41.7	875.96	-66.5	24.8	<12	165	< 300	Pass
+0	'EUT mitigates oscillation immediately, by reducing the gain but does not shut down								Pass

Oscillation Mitigation - Downlink									
Band	1930 - 1995 MHz								
Test Signal Type	CDMA								
Variable Attenuator Setting	Oscillations		Lowest Output Power Level		Margin	Limit	Time to Mitigate Oscillation	Mitigation Time Limit	Pass / Fail
	Freq.	Level	Freq.	Level					
dB	MHz	dBm	MHz	dBm	dB	dB	sec	sec	
+5	1973.63	-47.8	1972.29	-59.3	11.5	<12	N/A	N/A	Pass
+4	1973.63	-46.3	1972.29	-59.4	13.1	<12	154	< 300	Pass
+3	1973.63	-43.6	1972.29	-59.9	16.3	<12	169	< 300	Pass
+2	1973.63	-40.4	1972.29	-60.3	19.9	<12	164	< 300	Pass
+1	1973.63	-35.3	1972.29	-60.2	24.9	<12	170	< 300	Pass
+0	'EUT mitigates oscillation immediately, by reducing the gain but does not shut down								Pass

Oscillation Mitigation - Uplink									
Band	2110 - 2155 MHz								
Test Signal Type	CDMA								
Variable Attenuator Setting	Oscillations		Lowest Output Power Level		Margin	Limit	Time to Mitigate Oscillation	Mitigation Time Limit	Pass / Fail
	Freq.	Level	Freq.	Level					
dB	MHz	dBm	MHz	dBm	dB	dB	sec	sec	
+5	2126.03	-56.4	2124.72	-61.7	5.3	<12	N/A	N/A	Pass
+4	2126.03	-55.7	2124.72	-62	6.3	<12	N/A	N/A	Pass
+3	2126.03	-55.4	2124.72	-62.5	7.1	<12	N/A	N/A	Pass
+2	2126.03	-55.2	2124.72	-62.7	7.5	<12	N/A	N/A	Pass
+1	2126.03	-54.2	2124.72	-63	8.8	<12	N/A	N/A	Pass
+0	2126.03	-53.3	2124.72	-63.3	10	<12	N/A	N/A	Pass
-1	2126.03	-52.5	2124.72	-64.2	11.7	<12	N/A	N/A	Pass
-2	2126.03	-50.8	2124.72	-64.4	13.6	<12	145	< 300	Pass
-3	2126.03	-48.3	2124.72	-64.9	16.6	<12	165	< 300	Pass
-4	2126.03	-46.2	2124.72	-65.2	19	<12	145	< 300	Pass
-5	2126.03	-40.6	2124.72	-65.9	25.3	<12	164	< 300	Pass

Radiated Spurious

Engineer: Greg Corbin

Test Date: 2/9/2017

Test Procedure

The EUT was tested in a semi-anechoic chamber with the turntable set 3m from the receiving antenna. A spectrum analyzer was used to verify that the EUT met the requirements for Radiated Emissions. The EUT was tested by rotating it 360 degrees with the antenna in both the vertical and horizontal orientation while raised from 1 to 4 meters to ensure that the signal levels were maximized. All cable and antenna correction factors were input into the spectrum analyzer ensuring an accurate measurement in ERP/EIRP with the resultant power in dBm. A signal generator was used to provide a CW signal centered in each operational uplink and downlink band. The EUT output was terminated into a 50 Ohm non-radiating load.

The following formula was used for calculating the limits:

Radiated Spurious Emissions Limit = $P1 - (43 + 10\text{Log}(P2)) = -13\text{dBm}$

P1 = power in dBm

P2 = power in Watts

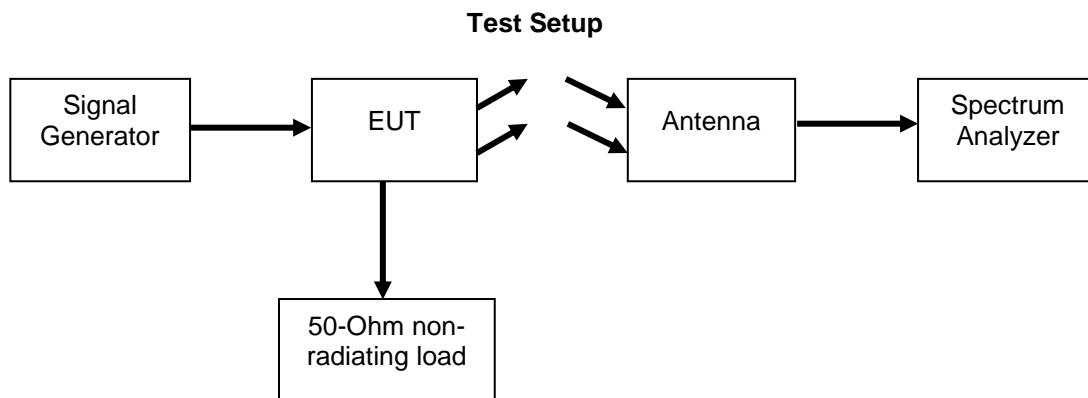

Refer to Annex J for Radiated Spurious Emission plots

No spurious emissions above the system noise floor were observed.
All emissions were lower than -13 dBm.

Test Equipment Utilized

Description	Manufacturer	Model #	CT Asset #	Last Cal Date	Cal Due Date
Horn Antenna	ARA	DRG-118/A	i00271	6/16/16	6/16/18
Humidity / Temp Meter	Newport	IBTHX-W-5	i00282	5/26/16	5/26/17
Bi-Log Antenna	Schaffner	CBL 6111D	i00349	8/3/16	8/3/18
EMI Analyzer	Agilent	E7405A	i00379	2/11/16	2/11/17**
Signal Generator	Rohde & Schwarz	SMU200A	i00405	1/22/16	1/22/17**
Spectrum Analyzer	Textronix	RSA5126A	i00424	3/28/16	3/28/17
3 Meter Semi-Anechoic Chamber	Panashield	3 Meter Semi-Anechoic Chamber	i00428	8/15/16	8/15/19
Preamplifier	Miteq	AFS44 00101 400 23-10P-44	i00509	N/A	N/A

** 30 day calibration extension approved by QA manager.

In addition to the above listed equipment standard RF connectors and cables were utilized in the testing of the described equipment. Prior to testing these components were tested to verify proper operation.

END OF TEST REPORT