

DRIVE 4G-X RV

RV Cellular Signal Booster

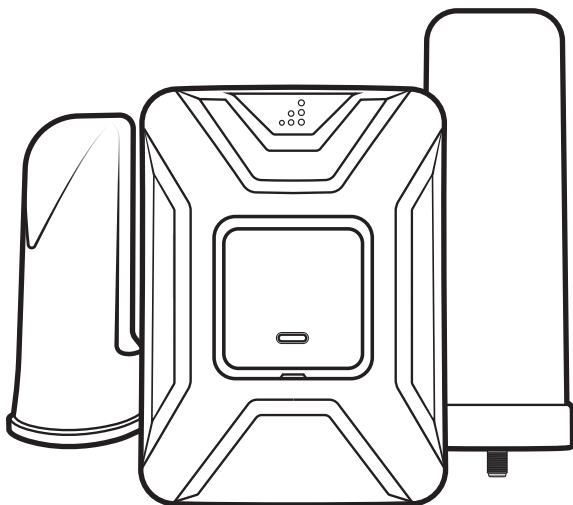

User Manual

NEED HELP?



support.weboost.com



866.294.1660

Index

Package Contents	1
STEP 1: Mount Outside Antenna	2
STEP 2: Drill Entry Hole	3
STEP 3: Connect Cable To Outside Antenna	4
STEP 4: Booster Location	6
STEP 5: Connect Outside Antenna Cable To Booster	7
STEP 6: Mount Cable Entry Cover	8
STEP 7: Connect Inside Antenna Cable To Booster	9
STEP 8: Power Up & Compare Results	10
Light Patterns	11
Troubleshooting	12
Safety Guidelines	14
Specifications	15
Warranty	17

Package Contents



Drive 4G-X
Booster

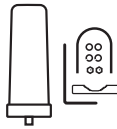

Outside
Antenna Kit



Inside Antenna +
13 foot Cable



20 Foot Cable
+ Cable Adapter



AC/DC Power
Supply

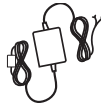

Hardwire Power
Supply



Cable Mounts +
Ties



Cable Entry
Cover



THE ALUMINUM CASING OF YOUR SIGNAL BOOSTER WILL ADJUST TO THE TEMPERATURE OF ITS ENVIRONMENT, BUT IS DESIGNED TO PROTECT THE SIGNAL BOOSTER TECHNOLOGY. FOR EXAMPLE, IN THE SUMMER, THE SIGNAL BOOSTER CASE MAY BE AS HOT AS 150 DEGREES INSIDE YOUR VEHICLE. THESE HIGH TEMPERATURES WILL NOT DAMAGE THE SIGNAL BOOSTER, NOR DO THEY POSE A FIRE RISK TO THE VEHICLE. AGAIN, BE SURE TO PLACE YOUR SIGNAL BOOSTER IN A LOCATION WITH ADEQUATE VENTILATION AND AWAY FROM DIRECT SUNLIGHT OR MOISTURE.



THE DRIVE 4G-X SIGNAL BOOSTER MAY REMAIN ON, IN VEHICLES WHOSE 12V DC POWER SOURCES DO NOT AUTOMATICALLY SHUTDOWN WHEN THE VEHICLE IS TURNED OFF. THIS COULD RESULT IN DISCHARGING THE VEHICLES BATTERY IN ONE TO TWO DAYS.

Step 1: Mount Outside Antenna

Determine where you want to have the outside antenna on your RV. Mount outside antenna to a pole or ladder so that the entire outside antenna is above the roof line of the RV and clear of other metal obstructions.

NOTE: This must be in a location within reach of the booster with the 20' coax cable (installed in Step 4).

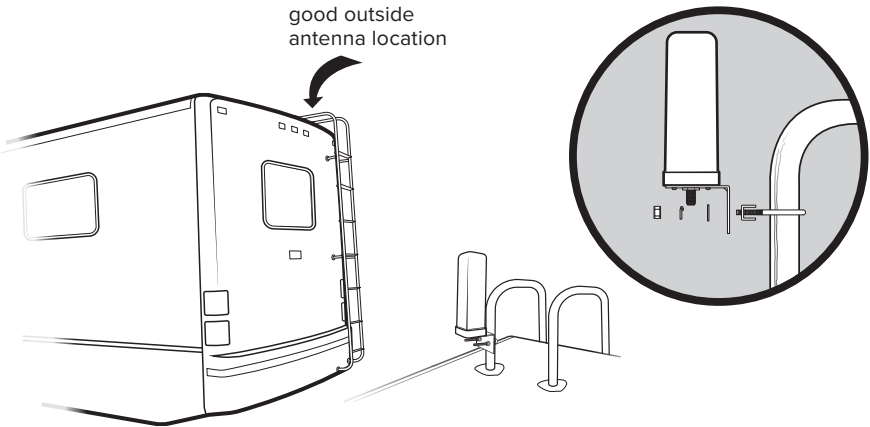



NOTE: Keep in mind to stay below the max height limit allowed by law, which varies from state to state (generally 14' in western states and 13'6" in eastern states).

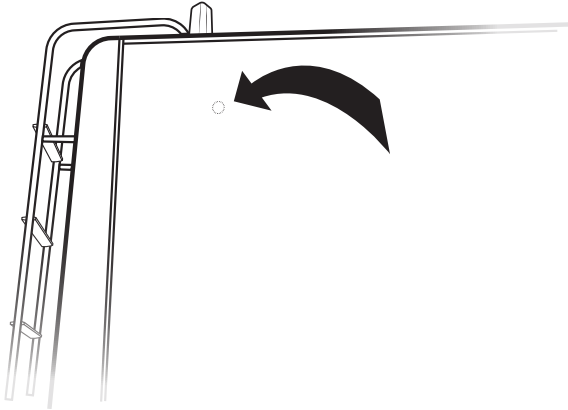

Step 2: Drill Hole

Drill a 1 inch hole toward the top of the RV that goes into the desired location. Do not put this hole on the top of the RV.



 **WARNING:** Be sure to stay clear of any power, pipes, etc. that may be damaged.

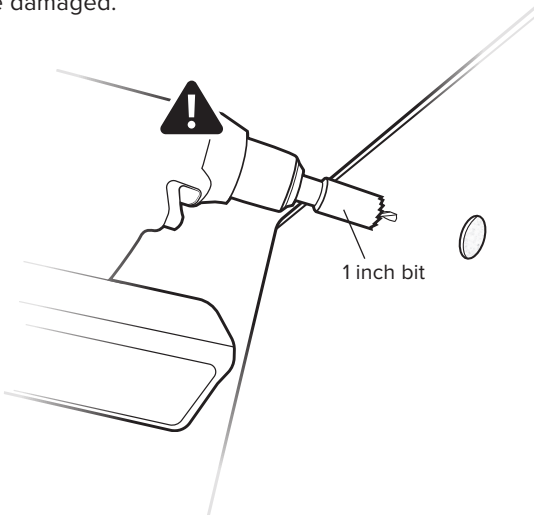

Step 3: Connect Cable To Outside Antenna

Connect the RG-6 cable to the outside antenna and route through the rubber ring of the cable entry cover, then into the newly drilled hole.

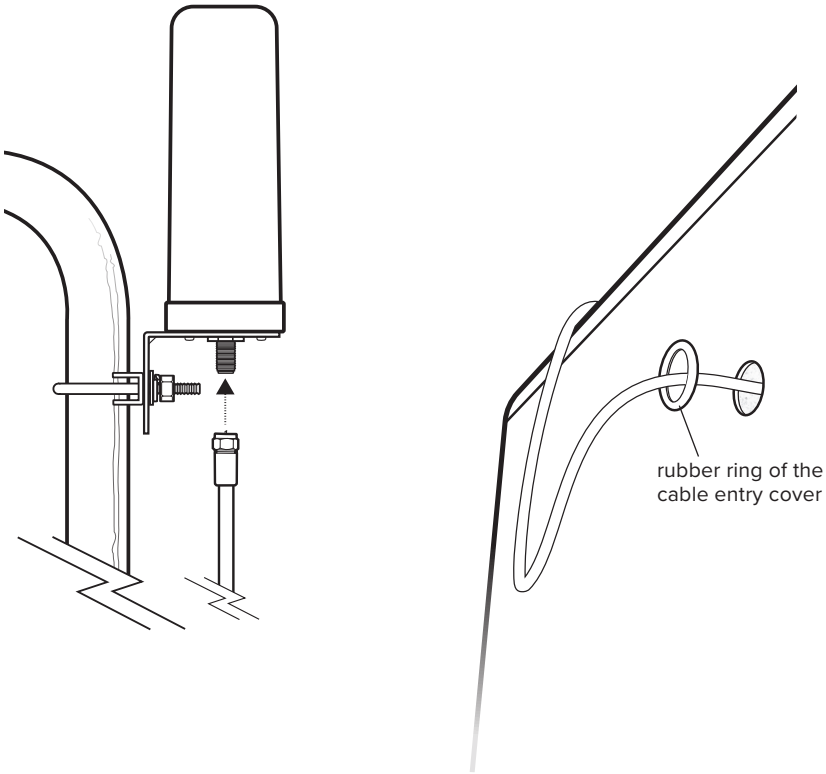

Step 4: Booster Location

Determine where you want to mount the booster, then mount by removing the mounting bracket, mounting the bracket, then placing the booster into the bracket.

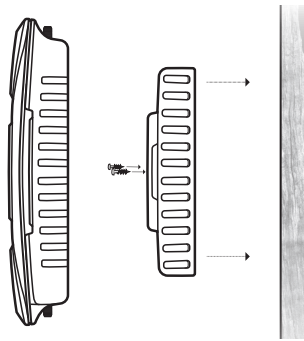

NOTE: We recommend in a cabinet near a power source. Be sure it's in a location that the 20' RG-6 cable can reach.

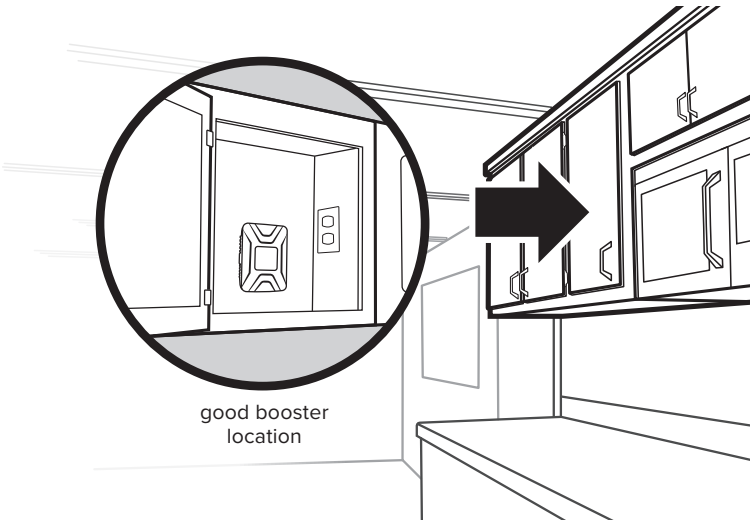

Step 5: Connect Outside Antenna Cable To Booster

Fasten the end with smaller SMA connection to the 'Outside Antenna' port on the booster.

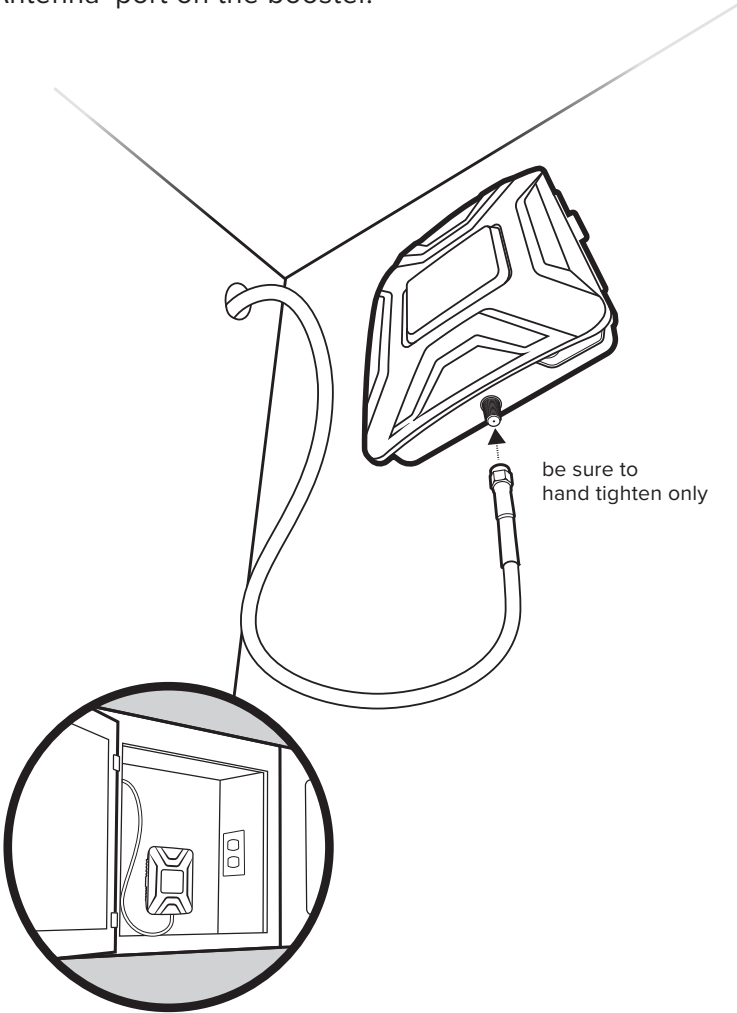

Step 6: Mount Cable Entry Cover

Make sure cable is through the rubber gasket and place the cable entry cover into the entry hole like shown & fasten cover to side of RV. Use the cable mounts and ties to secure to the RV.

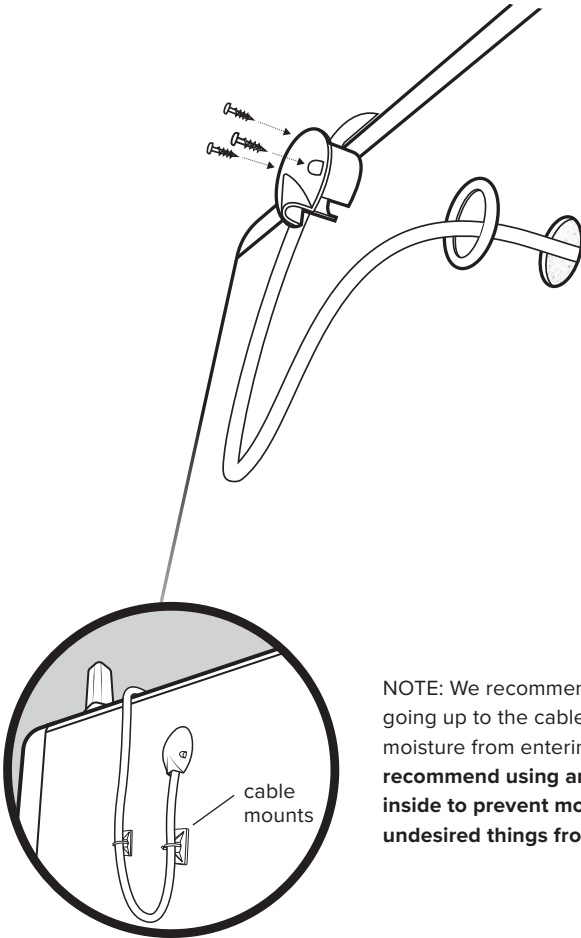

NOTE: We recommend putting a loop going up to the cable entry hole to prevent moisture from entering the RV. **We strongly recommend using an RTV sealant from the inside to prevent moisture, insects, & other undesired things from entering the RV.**

Step 7: Connect Inside Antenna Cable To Booster

Connect the 13' RG-58 cable to the 'Inside Antenna' port on the booster. Route the cable where you want to receive the boosted signal. Connect the inside antenna to the cable.

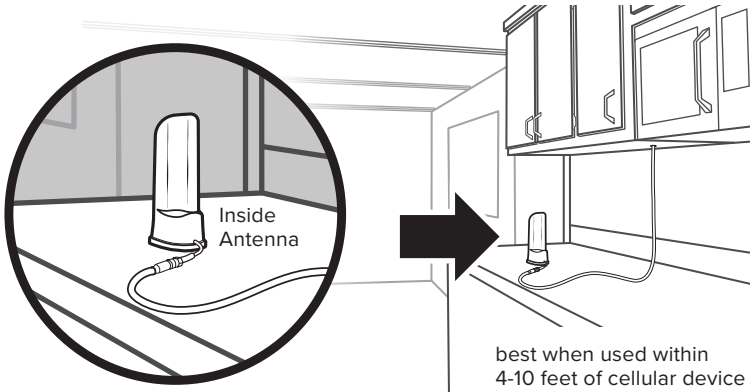
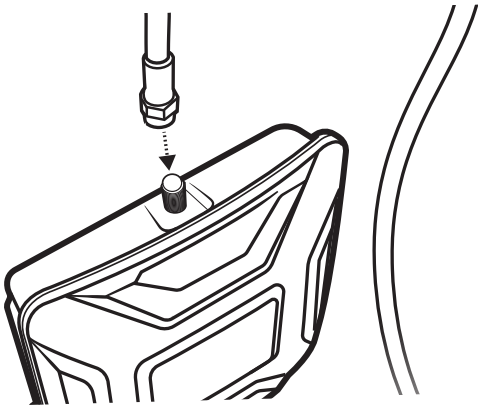

Step 8: Power Up The Booster

Connect 110V Wall plug to power and plug into booster and enjoy!

NOTE: We've included a fused 12V hardwire power supply option as well.

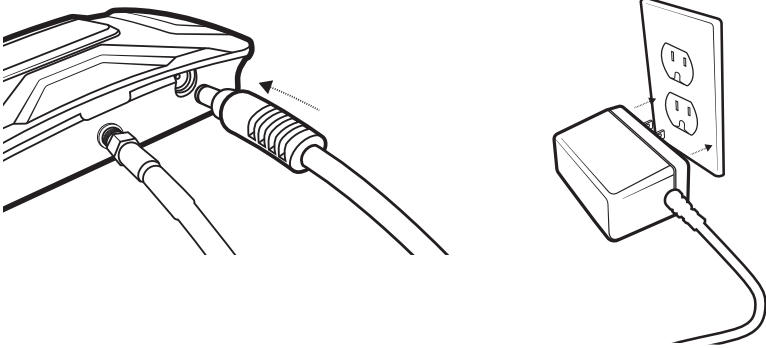

Measuring Booster Performance

Put your cell phone in field test mode and determine the signal inside your trailer. **Note it here:** _____

iPhone®

Dial *3001#12345## then press Call.

- 1 Hold down power button until you see 'Slide to Power Off'.
- 2 Then release the power button.
- 3 Hold the Home button until your main screen appears.

If you want to check 3G/1x but your iPhone is picking up 4G/LTE signal, go to Settings>Cellular>Cellular Data Options>Enable LTE>Select Off

Android™

Settings > About Phone > Status or Network > Signal Strength or Network Type and Strength (exact options/wording depends on phone model).

iPhone is a registered trademark of Apple Inc. Android is a trademark of Google Inc.

All Other Phones & Alternate Methods

- <https://www.weboost.com/test-mode-instructions/>





All Phones:

- Keep track of the network (3G or 4G) phone is connected to.
- Any signal readings you take are valid for that phone's carrier. To get readings from other carriers, you'll need phones from each carrier.
- When system is set-up, you can easily revert back to the "bar display" by dialing *3001#12345## press Call, press the signal strength at the top left of screen to toggle between numbers and bars, then press the Home button to exit Field Test mode.

(MEASURING BOOSTER PERFORMANCE cont.)

Compare Results

Having an accurate measurement of signal strength in decibels (dBm) is crucial when installing your system. Decibels accurately measure the signal strength you are receiving.

SIGNAL STRENGTH	EXCELLENT	GOOD	FAIR	POOR	DEAD ZONE
					
3G/1x	-70dBm	-71 to -85dBm	-86 to -100dBm	-101 to -109dBm	-110dBm
4G/LTE	-90dBm	-91 to -105dBm	-106 to -110dBm	-111 to -119dBm	-120dBm

Did you know a signal increase of just **3dB is 2 times the power** and signal amplification!

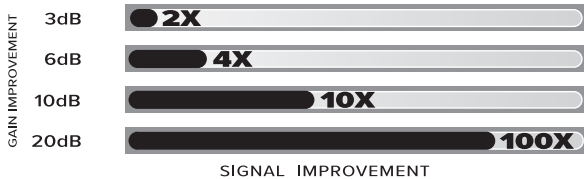

Light Patterns

Solid Green

This indicates that your booster is functioning properly and there are no issues with installation.

Blinking Red, Then Solid Green

This indicates that one or more of the booster bands has reduced power due to a feedback loop condition called oscillation. This is a built in safety feature to prevent harmful interference with a nearby cell tower. If you are already experiencing the desired signal boost, then no further adjustments are necessary. If you are not experiencing the desired boost in coverage then refer to the Troubleshooting section below.

Solid Red

This is due to a feedback loop condition called oscillation. This is a built in safety feature that causes a band to shut off to prevent harmful interference with a nearby cell tower. Refer to Troubleshooting section below.

Light Off

If the Drive 4G-X Signal Booster's light is off, verify your power supply has power.

NOTE: The Signal Booster can be reset by disconnecting and reconnecting the power supply.

After troubleshooting you must initiate a new power cycle by disconnecting and then reconnecting power to the Booster.

NEED HELP?



support.weboost.com



866.294.1660

Troubleshooting

FIXING BLINKING OR SOLID RED ISSUES

This section is only applicable if the booster is red or blinking red and you are not experiencing the desired signal boost.

- 1 Unplug the Booster's power supply.
- 2 Relocate the inside and outside antenna further from each other. The objective is to increase the separation distance between them, so that they will not create this feedback condition discussed before.
- 3 Plug power supply back in.
- 4 Monitor the indicator light on your booster. If, after a few seconds of 'power on', a solid or blinking red light appears, repeat steps 1 through 3. Increase the separation distance until the condition is corrected and/or desired coverage area is achieved. Note: Horizontal separation of the two antennas typically requires a shorter separation distance than perpendicular separation.
- 5 If you are having any difficulties while testing or installing your booster, contact our weBoost Customer Support team for assistance (866.294.1660).

FREQUENTLY ASKED QUESTIONS

What hours can I contact customer support?

Customer Support can be reached monday thru friday by calling **866.294.1660**, or through our support site at support.weboost.com.

Why do I need to create distance between the booster and the antenna?

Antennas connected to a booster create spheres of signal. When these spheres overlap, a condition called oscillation occurs. Oscillation can be thought of as noise, which causes the booster to shut down to prevent damage. The best way to keep these spheres of signal from overlapping is to maximize separation between the Booster and Antenna.

NEED HELP?



support.weboost.com



866.294.1660

Antenna Kit Options

MOBILE

Inside Antenna Options

Slim Low Profile

301152 - w/ 10' RG174

Low Profile

311106 - w/ 10' RG58

Desktop

311249 - w/ 13' RG58

Outside Antenna Options

Mini-Mag

301126 w/ 12.5 RG174 cable - SMA

301113 w/ 12.5 RG174 cable - FME

12" Mag Mount w/12.5' RG58

301103

311125

311128

314202

311703

Trucker Antenna w/10.5' RG58

311101

311701

Trucker Antenna w/13.5' RG58

311119

311133

4G Trucker Antenna w/15' RG58

304415

304414

Marine Antenna w/10' RG58

311130-5810

4G Marine Antenna w/20' L-195

304416

304420

Glass Mount w/14' RG58

311102

NMO Antenna w/RG58

Kit 311104-5810

800/1900 NMO Antenna

10' RG58 Cable

Kit 311112-5810

800/1900 NMO Antenna

10' RG58 Cable

Kit 314203-5810

800/900/1900 NMO Antenna

10' RG58 Cable

INSIDE FIXED

Inside Antenna Expansion Kit

Kit 309900-50N40090

2 - Wall Panel antennas

1 - 50 ohm 3-Way Splitter

Kit 309905-50N

3 - Wall Panel Antennas

3 - 2-Way 50 Ohm Splitters

20' RG174

Kit 309902-75F

2 - Wall Panel Antennas

1 - 3-Way 75Ohm Splitter

Kit 309903-75F

3 - Wall Panel Antennas

3 - 2-Way 75Ohm Splitters

Kit 309904-75F

1 - Wall Panel Antenna

1 - 2-Way 75 Ohm Splitter

Inside Antenna Kits

Kit 311155-0630

75 Ohm Wall mount Panel Antenna

30' RG6 Cable

Kit 311135-5820

50 Ohm Wall mount Panel Antenna

20' RG58 Cable

Kit 311135-40060

50 Ohm Wall mount Panel Antenna

60' Wilson 400

Kit 311155-1150

75 Ohm Wall mount Panel Antenna

50' RG11 cable

Kit 311155-40060

75 Ohm 4G Dome Antenna

60' Wilson 400 cable

Kit 304412-40010

50 Ohm 4G Dome Antenna

10' Wilson 400 cable

Kit 304412-5810

50 Ohm 4G Dome Antenna

10' RG 11 cable

Kit 304419-1110

75 Ohm 4G Dome Antenna

10' RG11 cable

Kit 304419-17410

75 Ohm 4G Dome Antenna

10' RG174 cable

May need separate adapter

Kit 304419-1610

75 Ohm 4G Dome Antenna

10' RG6 cable

Kit 301211

Desktop Antenna w/5' RG174

OUTSIDE FIXED

50 Ohm Outside Antenna Kits

Kit 314453-5825

50 Ohm Pole Mount Panel Antenna

25' RG58 Cable

Kit 314411-5825

50 Ohm Wide Band Directional

25' RG58 Cable

Kit 301111-5850

Yagi Directional Antenna

50' RG58 Cable

Kit 311203-5820

Omni-Directional antenna

20' RG58 Cable

Kit 314411-40075

50 Ohm Wide Band Directional

75' LMR400 Cable

Kit 311203-40020

Omni-Directional antenna

20' LMR400 Cable

Kit 301111-400170

Yagi Directional w/ N-Female

170' LMR400

Kit 314453-40075

50 Ohm Pole Mount Panel Antenna

75' LMR400 Cable

Kit 304422-40020

50 Ohm 4G Omni Antenna

20' Wilson400 cable

Kit 304422-5810

50 Ohm 4G Omni Antenna

10' RG58 cable

Kit 304422-1120

50 Ohm 4G Omni Antenna

20' RG11 cable

May need separate adapter

75 Ohm Outside Antenna Kits

Kit 301111-0675

Yagi Directional Antenna

75' RG6 Cable

N-Male to F-Female adapter

Kit 311201-0620

Omni Directional w/ F-Female

20' RG6 Cable

Kit 314473-0640

75 Ohm Pole Mount Panel Antenna

40' RG6 Cable

Kit 311141-0620

75 Ohm Grey Brick Antenna

20' RG6 Cable

Kit 301111-11140

Yagi Directional Antenna

140' RG11 Cable

N-Male to F-Female adapter

Kit 311201-1120

Omni Directional w/ F-Female

20' RG11 Cable

Kit 314473-1175

75 Ohm Pole Mount Panel Antenna

75' RG11 Cable

Kit 314475-0630

75 Ohm Wide Band Directional

30' RG6 Cable

Kit 314475-1175

75 Ohm Wide Band Directional

75' RG11 Cable

Kit 311141-1120

75 Ohm Grey Brick Antenna

20' RG11 Cable

Kit 304421-17410

75 Ohm 4G Omni Antenna

10' RG174 cable

Kit 304421-0610

75 Ohm 4G Omni Antenna

10' RG6 cable

Kit 304421-5810

75 Ohm 4G Omni Antenna

10' RG58 cable

May need separate adapter

Kit 304421-1120

75 Ohm 4G Omni Antenna

20' RG 11 cable

Safety Guidelines

Use only the power supply provided in this package. Use of a non-weBoost product may damage your equipment.

The Signal Booster unit is designed for use in an indoor, temperature-controlled environment (less than 150 degrees Fahrenheit). It is not intended for use in attics or similar locations subject to temperatures in excess of that range.

The desktop antenna must have at least 3' of separation distance from all active users. All inside panel and dome antennas must have at least 6' of separation distance from all active users, and low profile antennas must have at least 1.5' separation distance from all active users.

Connecting the Signal Booster directly to the cell phone with use of an adapter will damage the cell phone.

RF Safety Warning: Any antenna used with this device must be located at least 8 inches from all persons.

AWS Warning: The Outside Antenna must be installed no higher than 31 feet 9 inches (10 meters) above ground.

This is a CONSUMER device.

BEFORE USE, you meet all requirements set out in CPC-2-1-05.

BEFORE USE, you **MUST REGISTER THIS DEVICE** with your wireless provider and have your provider's consent. Most wireless providers consent to the use of signal boosters. Some providers may not consent to the use of this device on their network. If you are unsure, contact your provider.

You **MUST** operate this device with approved antennas and cables as specified by the manufacturer. Antennas **MUST** be installed at least 20 cm (8 inches) from any person.

You **MUST** cease operating this device immediately if requested by the FCC, ISED or a licensed wireless service provider.

WARNING. E911 location information may not be provided or may be inaccurate for calls served by using this device.

FOR MORE INFORMATION ON REGISTERING YOUR SIGNAL BOOSTER WITH YOUR WIRELESS PROVIDER, PLEASE SEE BELOW:

Sprint: http://www.sprint.com/legal/fcc_boosters.html

T-Mobile/MetroPCS: <https://support.t-mobile.com/docs/DOC-9827>

Verizon Wireless: <http://www.verizonwireless.com/wcms/consumer/register-signal-booster.html>

AT&T: <https://securec45.securewebsession.com/attsignalbooster.com/>

U.S. Cellular: <http://www.uscellular.com/uscellular/support/fcc-booster-registration.jsp>

Specifications

Drive 4G-X

Product Number	U470010					
Model Number	460021					
FCC ID:	PWO460021					
IC:	4726A-460021					
Connectors	SMA-Female					
Antenna Impedance	50 Ohms					
Frequency	699-716 MHz, 729-756 MHz, 777-786 MHz, 824-894 MHz, 1850-1995 MHz, 1710-1755 MHz/2110-2155 MHz					
Passband Gain (nominal)	700 MHz Band 12/17 45.8	700 MHz Band 13 46.8	800 MHz Band 5 46.8	1700/2100 MHz Band 4 45.2	1900 MHz Band 2 44.6	
20 dB Bandwidth (MHz)	700 MHz Band 12/17	700 MHz Band 13	800 MHz Band 5	1700/2100 MHz Band 4	1900 MHz Band 2	
	Typical	30.6	31.0	37.9	79.2	
	Maximum	35.2	35.2	39.9	79.8	
Power output for single cell phone (Uplink) dBm	Maximum Power					
	700 MHz Band 12/17 24.84	700 MHz Band 13 24.35	800 MHz Band 5 23.4	1700 MHz Band 4 21.3	1900 MHz Band 2 24.43	
Power output for single cell phone (Downlink) dBm	Maximum Power					
	700 MHz Band 12/17 2.87	700 MHz Band 13 2.79	800 MHz Band 5 2.8	2100 MHz Band 4 2.0	1900 MHz Band 2 1.92	
Power output for multiple received channels (Uplink) dBm	Maximum Power					
	No. Tones	700 MHz Band 12/17	700 MHz Band 13	800 MHz Band 5	1700 MHz Band 4	1900 MHz Band 2
	2	25.4	23.9	22.9	22.8	24.9
	3	21.8	20.4	19.4	19.3	21.3
	4	19.3	17.9	16.9	16.8	18.8
	5	17.4	16.0	15.0	14.8	16.9
	6	15.8	14.4	13.4	13.2	15.3
Power output for multiple received channels (Downlink) dBm	Maximum Power					
	No. Tones	700 MHz Band 12/17	700 MHz Band 13	800 MHz Band 5	2100 MHz Band 4	1900 MHz Band 2
	2	4.8	5.6	5.4	6.3	4.5
	3	1.3	2.1	1.9	2.8	0.9
	4	-1.2	-0.4	-0.6	0.3	-1.6
	5	-3.2	-2.4	-2.6	-1.6	-3.5
	6	-4.7	-4.0	-4.2	-3.2	-5.1
Noise Figure	5 dB nominal					
Isolation	> 90 dB					
Power Requirements	6 V 2 A					

(SPECIFICATIONS cont.)

The term "IC" before the radio certification number only signifies that Industry Canada technical specifications were met.

Each Signal Booster is individually tested and factory set to ensure FCC compliance. The Signal Booster cannot be adjusted without factory reprogramming or disabling the hardware. The Signal Booster will amplify, but not alter incoming and outgoing signals in order to increase coverage of authorized frequency bands only. If the Signal Booster is not in use for five minutes, it will reduce gain until a signal is detected. If a detected signal is too high in a frequency band, or if the Signal Booster detects an oscillation, the Signal Booster will automatically turn the power off on that band. For a detected oscillation the Signal Booster will automatically resume normal operation after a minimum of 1 minute. After 5 (five) such automatic restarts, any problematic bands are permanently shut off until the Signal Booster has been manually restarted by momentarily removing power from the Signal Booster. Noise power, gain, and linearity are maintained by the Signal Booster's microprocessor.

The Manufacturer's rated output power of this equipment is for single carrier operation. For situations when multiple carrier signals are present, the rating would have to be reduced by 3.5 dB, especially where the output signal is re-radiated and can cause interference to adjacent band users. This power reduction is to be by means of input power or gain reduction and not by an attenuator at the output of the device.

This device complies with Part 15 of FCC rules. Operation is subject to two conditions: (1) This device may not cause harmful interference, and (2) this device must accept any interference received, including interference that may cause undesired operation. Changes or modifications not expressly approved by weBoost could void the authority to operate this equipment.



2 YEAR WARRANTY

weBoost Signal Boosters are warranted for two (2) years against defects in workmanship and/or materials. Warranty cases may be resolved by returning the product directly to the reseller with a dated proof of purchase.

Signal Boosters may also be returned directly to the manufacturer at the consumer's expense, with a dated proof of purchase and a Returned Material Authorization (RMA) number supplied by weBoost. weBoost shall, at its option, either repair or replace the product.

This warranty does not apply to any Signal Boosters determined by weBoost to have been subjected to misuse, abuse, neglect, or mishandling that alters or damages physical or electronic properties.

Replacement products may include refurbished weBoost products that have been recertified to conform with product specifications.

RMA numbers may be obtained by contacting Customer Support

DISCLAIMER: The information provided by weBoost is believed to be complete and accurate. However, no responsibility is assumed by weBoost for any business or personal losses arising from its use, or for any infringements of patents or other rights of third parties that may result from its use.



3301 East Deseret Drive, St. George, UT

866.294.1660 www.weboost.com support.weboost.com

Copyright © 2016 weBoost. All rights reserved.

weBoost products covered by U.S. patent(s) and pending application(s)

For patents go to: weboost.com/us/patents