



849 NW STATE ROAD 45
NEWBERRY, FL 32669 USA
PH: 888.472.2424 OR 352.472.5500
FAX: 352.472.2030
EMAIL: TEI@TIMCOENGR.COM
[HTTP://WWW.TIMCOENGR.COM](http://WWW.TIMCOENGR.COM)

FCC PART 22H, PART 24E AND 27 TEST REPORT

Applicant	WILSON ELECTRONICS, INC.
Address	3301 E. DESERET DRIVE ST. GEORGE UTAH 84790 USA
FCC ID	PWO2B2725
Model Number	2B2725
Product Description	WIRELESS, TRI-BAND SIGNAL BOOSTER
Date Sample Received	7/25/2012
Date Tested	7/30/2012
Tested By	Nam Nguyen
Approved By	Mario de Aranzeta
Report No.	1851AUT12TestReport.doc
Test Results	<input checked="" type="checkbox"/> PASS <input type="checkbox"/> FAIL

THE ATTACHED REPORT SHALL NOT BE REPRODUCED EXCEPT IN FULL
WITHOUT THE WRITTEN APPROVAL OF TIMCO ENGINEERING, INC.



Test Certificate #0955-01



TABLE OF CONTENTS

ATTESTATION STATEMENT 4

REPORT SUMMARY 5

TEST ENVIRONMENT 5

TEST SETUP 5

DEVICE UNDER TEST INFORMATION 6

EQUIPMENT LIST 7

TEST PROCEDURE 8

RF POWER OUTPUT 11

 Test Data Table 1 – Output Power – CDMA 1900 – Uplink/Downlink 11

 Test Data Table 2 – Output Power – EVDO 1900 – Uplink/Downlink 11

 Test Data Table 3 – Output Power – HSPA 1900 – Uplink/Downlink 11

 Test Data Table 4 – Output Power – LTE 1900 – Uplink/Downlink 11

 Test Data Table 5 – Output Power – GSM 1900 – Uplink/Downlink 12

 Test Data Table 6 – Output Power – EDGE 1900 – Uplink/Downlink 12

 Test Data Table 7 – Output Power – CDMA 1700 – Uplink/Downlink 12

 Test Data Table 8 – Output Power – EVDO 1700 – Uplink/Downlink 12

 Test Data Table 9 – Output Power – HSPA 1700 – Uplink/Downlink 12

 Test Data Table 10 – Output Power – LTE 1700 – Uplink/Downlink 13

 Test Data Table 11 – Output Power – GSM 1700 – Uplink/Downlink 13

 Test Data Table 12 – Output Power – EDGE 1700 – Uplink/Downlink 13

 Test Data Table 13 – Output Power – CDMA 800 – Uplink/Downlink 13

 Test Data Table 14 – Output Power – EVDO 800 – Uplink/Downlink 13

 Test Data Table 15 – Output Power – HSPA 800 – Uplink/Downlink 14

 Test Data Table 16 – Output Power – LTE 800 – Uplink/Downlink 14

 Test Data Table 17 – Output Power – GSM 800 – Uplink/Downlink 14

 Test Data Table 18 – Output Power – EDGE 800 – Uplink/Downlink 14

INPUT/OUTPUT MODULATED AMPLITUDE COMPARISON AND BAND-EDGES COMPLIANCE 15

 Test Data Table 19 – CDMA 1900 – Uplink/Downlink 16

 Test Data Table 20 – EVDO 1900 – Uplink/Downlink 20

 Test Data Table 21 – HSPA 1900 – Uplink/Downlink 24

 Test Data Table 22 – LTE 1900 – Uplink/Downlink 28

 Test Data Table 23 – GSM 1900 – Uplink/Downlink 32

 Test Data Table 24 – EDGE 1900 – Uplink/Downlink 36

 Test Data Table 25 – CDMA 1700 – Uplink/Downlink 40

 Test Data Table 26 – EVDO 1700 – Uplink/Downlink 44

 Test Data Table 27 – HSPA 1700 – Uplink/Downlink 48

 Test Data Table 28 – LTE 1700 – Uplink/Downlink 52

 Test Data Table 29 – GSM 1700 – Uplink/Downlink 56

 Test Data Table 30 – EDGE 1700 – Uplink/Downlink 60

 Test Data Table 31 – CDMA 800 – Uplink/Downlink 64

 Test Data Table 32 – EVDO 800 – Uplink/Downlink 68

 Test Data Table 33 – HSPA 800 – Uplink/Downlink 72

 Test Data Table 18 – LTE 800 – Uplink/Downlink 76

 Test Data Table 35 – GSM 800 – Uplink/Downlink 80

APPLICANT: WILSON ELECTRONICS, INC.

FCC ID: PWO2B2725

Report #: W\WILSON_PWO\1851AUT12\1851AUT12TestReport.doc



Test Data Table 36 – EDGE 800 – Uplink/Downlink 84

INTERMODULATION PRODUCT SPURIOUS EMISSIONS 88

 1900 MHz 89

 1700 MHz 91

 800 MHz 93

SPURIOUS EMISSIONS AT ANTENNA TERMINALS..... 101

 Test Data Table 37 – Conducted Emissions – CDMA 1900 – Uplink 101

 Test Data Table 38 – Conducted Emissions – CDMA 1900 – Downlink 101

 Test Data Table 39 – Conducted Emissions – GSM 1900 - Uplink 102

 Test Data Table 40 – Conducted Emissions – GSM 1900 - Downlink..... 102

 Test Data Table 41 – Conducted Emissions – CDMA 1700 - Uplink..... 103

 Test Data Table 42 – Conducted Emissions – CDMA 1700 - Downlink 103

 Test Data Table 43 – Conducted Emissions – GSM 1700 – Uplink 104

 Test Data Table 44 – Conducted Emissions – GSM 1700 - Downlink..... 104

 Test Data Table 45 – Conducted Emissions – CDMA 800 - Uplink..... 105

 Test Data Table 46 – Conducted Emissions – CDMA 800 – Downlink 105

 Test Data Table 47 – Conducted Emissions – GSM 800 - Uplink 106

 Test Data Table 48 – Conducted Emissions – GSM 800 - Downlink..... 106

FIELD STRENGTH OF SPURIOUS EMISSIONS 107

 Test Data Table 49 – Radiated Emissions – CW (1900 MHz) – Uplink /Downlink107

 Test Data Table 50 – Radiated Emissions – CW (1700 MHz) – Uplink /Downlink108

 Test Data Table 51 – Radiated Emissions – CW (800 MHz) – Uplink /Downlink. 108

OUT OF BAND REJECTION: FREQUENCY RESPONSE 109

 1900 MHz 109

 1700 MHz 111

 800 MHz 113

ATTESTATION STATEMENT

Summary

The device under test does:

- fulfill the general approval requirements as identified in this test report
- not fulfill the general approval requirements as identified in this test report

This equipment has been tested in accordance with the standards identified in this test report. To the best of my knowledge and belief, these tests were performed using the measurement procedures described in this report. All instrumentation and accessories used to test products for compliance to the indicated standards are calibrated regularly in accordance with ISO 17025:2005 requirements.



Certificate # 0955-01

I attest that the necessary measurements were made, under my supervision, at TIMCO ENGINEERING, INC. located at 849 N.W. State Road 45, Newberry, Florida 32669.

Authorized Signatory Name: Mario de Aranzeta



Signature:

Function: Engineer

Date: 8/16/2012

REPORT SUMMARY

Disclaimer	The test results relate only to the items tested.
Report Purpose	To demonstrate the DUT comply with FCC Part 22H and Pt 24 and Industry Canada RS-131 requirements for a dual band signal amplifier.
Applicable Rule Part(s)	Pt 22, Pt 24, Pt 15.109
Test Procedure(s)	ANSI/TIA-603-C: 2004

TEST ENVIRONMENT

Test Facilities	All required tests were performed by Timco Engineering Inc. that is located at 849 NW State Road 45 Newberry, FL 32669.
Test Conditions	Temperature: 26°C Relative Humidity: 50%

TEST SETUP

Deviation to the rules	There was no deviation from the test standards.
Modification to the DUT	No modification was made to the DUT.
Test Exercise (e.g. software description, test signal, etc.)	The DUT was placed in continuous transmit mode of operation.

DEVICE UNDER TEST INFORMATION

Manufactured by	WILSON ELECTRONICS, INC.
DUT Description	WIRELESS, TRI-BAND SIGNAL BOOSTER
FCC ID	PWO2B2725
Model Name	2B2725
Operating Frequency	Uplink 824 – 849 MHz Downlink 869 – 894 MHz Uplink 1850 – 1910 MHz Downlink 1930 – 1990 MHz Uplink 1710 – 1755 MHz Downlink 2110 – 2155 MHz
Emission Designators	F9W (CDMA & HSPA), GXW (GSM), G7W (EDGE), G7D (LTE)
Modulation(s)	CDMA, HSPA, GSM, EDGE, LTE, EVDO
User Power Range & Control	There are NO user power controls
Test Item	Pre-Production
DC Voltage and Current into final amplifier	Power Into Final Amplifier (uplink) Vcc = 4.0Vdc, 0.5 A Power Input (downlink) Vcc= 4.0Vdc, 0.5 A
Type of Equipment	Fixed and Mobile

EQUIPMENT LIST

Device	Manufacturer	Model	Serial Number	Cal/Char Date	Due Date
3-Meter Semi-Anechoic Chamber	Panashield	N/A	N/A	Listed 5/1/12	5/1/14
AC Voltmeter	HP	400FL	2213A14499	CAL 6/12/11	6/12/13
Antenna: Active Loop	ETS-Lindgren	6502	00062529	CAL 9/23/10	9/23/12
Frequency Counter	HP	5385A	2730A03025	CAL 8/17/11	8/17/13
Hygro-Thermometer	Extech	445703	0602	CAL 6/15/11	6/15/13
Modulation Analyzer	HP	8901A	3435A06868	CAL 7/18/11	7/18/13
Digital Multimeter	Fluke	FLUKE-77	35053830	CAL 9/9/11	9/9/13
Power Meter	Boonton Electronics	4531	11793	CAL 11/12/2010	11/12/2012
EMI Receiver	Rohde & Schwarz	ESIB40	100274	CAL 3/16/2012	3/16/2014
Analyzer Tan Tower Preamplifier	HP	8449B-H02	3008A00372	CAL 10/28/11	10/28/13
Analyzer Tan Tower Quasi-Peak Adapter	HP	85650A	3303A01690	CAL 10/28/11	10/28/13
Analyzer Tan Tower RF Preselector	HP	85685A	3221A01400	CAL 10/28/11	10/28/13
Analyzer Tan Tower Spectrum Analyzer	HP	8566B Opt 462	3138A07786 3144A20661	CAL 10/28/11	10/28/13
Antenna	ETS	3117	35923	12/7/2011	12/7/2013
Antenna	Electro metrics	LPA-25	1122	5/04/2011	5/04/2013
Antenna	Electro metrics	BIA-25	1096	5/04/2011	5/04/2013

APPLICANT: WILSON ELECTRONICS, INC.

FCC ID: PWO2B2725

Report #: W\WILSON_PWO\1851AUT12\1851AUT12TestReport.doc

TEST PROCEDURE

RF Power Output

RF power is measured by connecting a 50-ohm, resistive wattmeter to the RF output connector. With a nominal voltage and the amplifier properly adjusted the RF output measures.

RF Output Power Test Setup Diagram

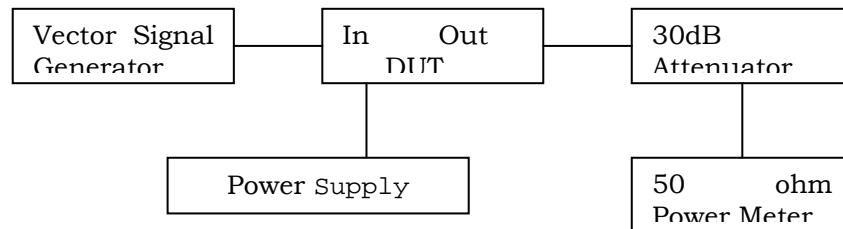

Input/Output Modulated Amplitude Comparison And Band-Edges Compliance

On the following plot, the reference level was calibrated using a resolution bandwidth wider than the emission bandwidth. First the gain was measured for the maximum output power. Then for each frequency and type of modulation, an attenuation equals to the gain of the amplifier was added on the measurement side of the amplifier, as to overlay the input versus output modulated envelope.

Test Setup Diagram

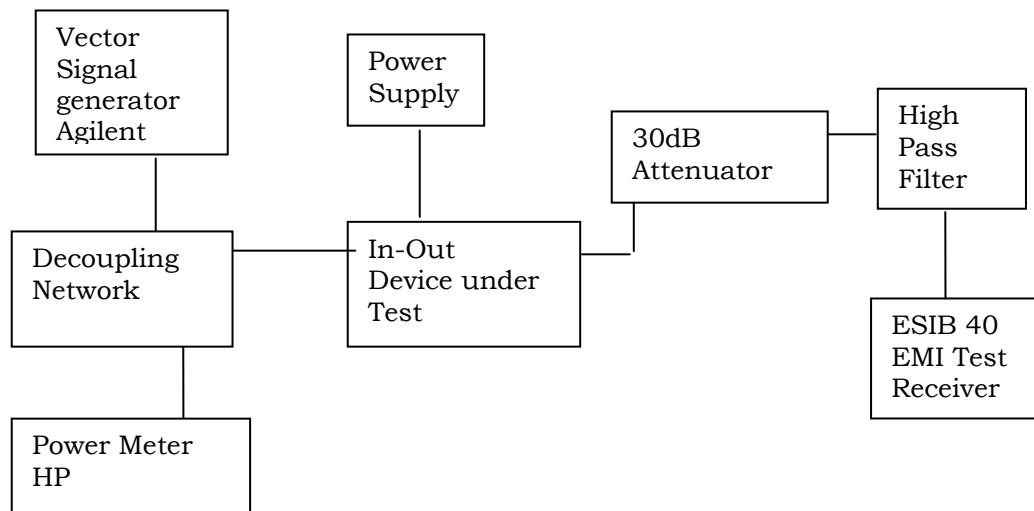

[Continued]

Intermodulation Product Spurious Emissions

The procedure used was ANSI/TIA-603-C: 2004. The spectrum was scanned from 9kHz to at least the tenth harmonic of the fundamental using a HP 8566B spectrum analyzer.

The modulation type was tested using the two-tone / three tone test method. The input power to the amplifier was set at maximum drive level by combining the two tones. The two tones were chosen in such a way (1) the third order intermodulation product frequencies are located within the pass band of the DUT and (2) they produce the worst-case emissions out of band.

Setup Diagram

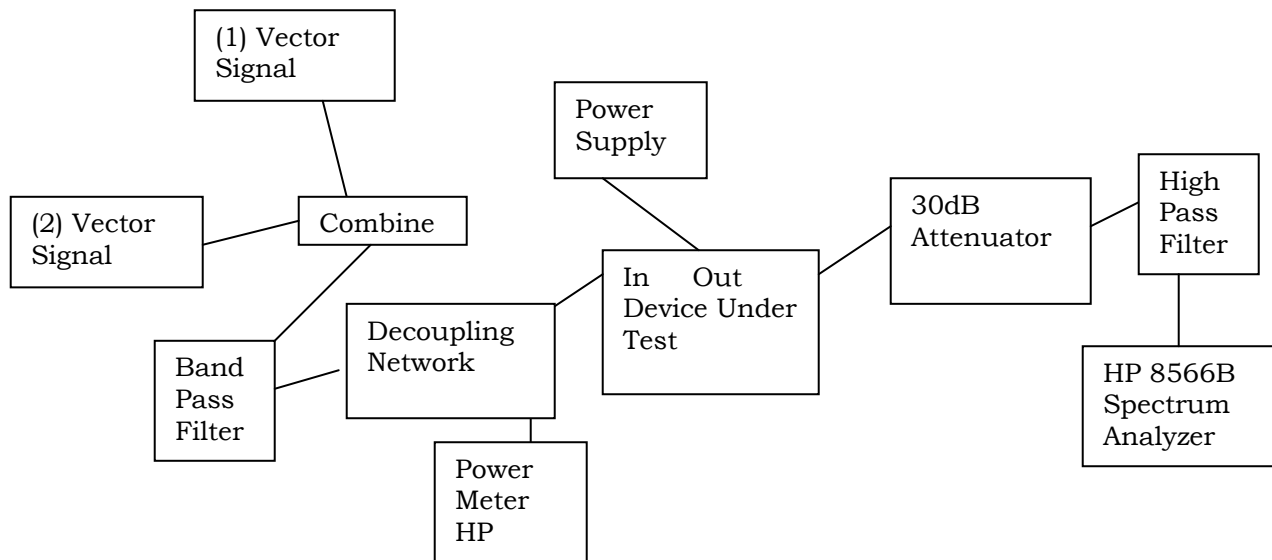

Spurious Emissions at Antenna Terminals

The procedure used was ANSI/TIA-603-C: 2004. The spectrum was scanned from 9kHz to at least the tenth harmonic of the fundamental using a HP model 8566B spectrum analyzer.

Data on the following page shows the level of conducted spurious responses. For analog modulation, the carrier was modulated 100% using a 2500 Hz tone. For digital modulation, the carrier is modulated to its maximum extent. The spectrum was scanned from 9 kHz to at least the 10th harmonic of the fundamental. The measurements were made in accordance with standard ANSI/TIA-603-C: 2004. The maximum input power was set for each test.

[Continued]

Conducted Spurious Emissions Test Setup Diagram

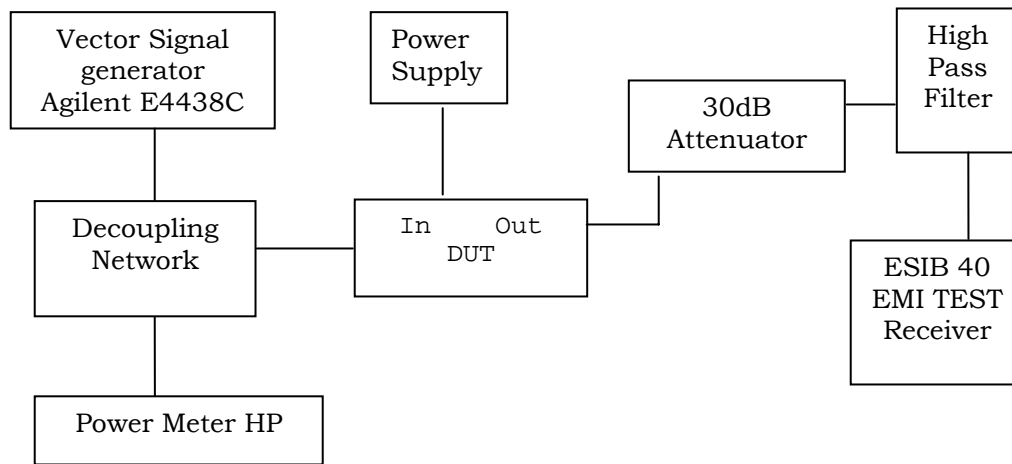

Radiated Spurious Emissions

The spectrum was scanned from 30 MHz to at least the tenth harmonic of the fundamental. The CW signal was used to perform this test. This test was conducted per ANSI/TIA-603-C: 2004 using the substitution method.

Radiated Spurious Emissions Test Setup Diagram

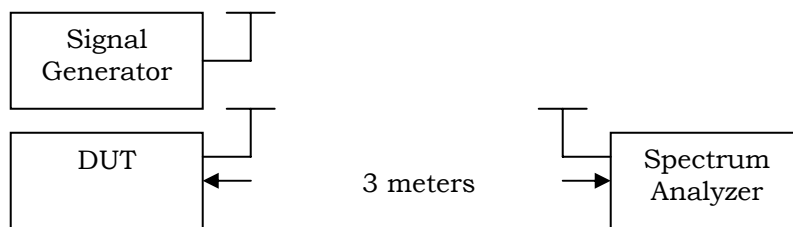

Equipment placed 80 cm above ground on a rotating table platform.

RF POWER OUTPUT

Rule Part(s) No.: Pt 2.1046(a)

Requirements: Pt 2.1046(a)

Test Result: As the following table indicates. Notes: the maximum power output value was obtained with CDMA modulation at 836.5MHz and 1960MHz.

Test Data Table 1 – Output Power – CDMA 1900 – Uplink/Downlink

Tuned Frequency (MHz)	Power Input (dBm)	Power Output (dBm)	Power Output (mW)	Tuned Frequency (MHz)	Power Input (dBm)	Power Output (dBm)	Power Output (mW)
1851.25	7.4	26.2	417	1931.25	-28.0	-9.3	0.12
1880.00	7.4	28.2	661	1960.00	-28.0	-7.0	0.2
1908.75	9.4	25.1	324	1988.75	-28.0	-10.0	0.1

Test Data Table 2 – Output Power – EVDO 1900 – Uplink/Downlink

Tuned Frequency (MHz)	Power Input (dBm)	Power Output (dBm)	Power Output (mW)	Tuned Frequency (MHz)	Power Input (dBm)	Power Output (dBm)	Power Output (mW)
1851.25	7.4	26.0	398	1931.25	-28.0	-8.9	0.13
1880.00	7.4	28.1	646	1960.00	-28.0	-7.8	0.17
1908.75	9.4	24.8	302	1988.75	-28.0	-9.6	0.11

Test Data Table 3 – Output Power – HSPA 1900 – Uplink/Downlink

Tuned Frequency (MHz)	Power Input (dBm)	Power Output (dBm)	Power Output (mW)	Tuned Frequency (MHz)	Power Input (dBm)	Power Output (dBm)	Power Output (mW)
1852.50	5.4	24.6	288	1932.50	-30.0	-9.8	0.1
1880.00	5.4	26.2	417	1960.00	-30.0	-9.0	0.13
1907.50	7.4	23.5	224	1987.50	-29.0	-9.7	0.11

Test Data Table 4 – Output Power – LTE 1900 – Uplink/Downlink

Tuned Frequency (MHz)	Power Input (dBm)	Power Output (dBm)	Power Output (mW)	Tuned Frequency (MHz)	Power Input (dBm)	Power Output (dBm)	Power Output (mW)
1855.00	4.4	25.3	339	1935.00	-30.0	-9.4	0.11
1880.00	4.4	26.8	479	1960.00	-30.0	-8.8	0.13
1905.00	5.4	23.3	214	1985.00	-29.0	-9.7	0.11

[Continued]



Test Data Table 5 – Output Power – GSM 1900 – Uplink/Downlink

Tuned Frequency (MHz)	Power Input (dBm)	Power Output (dBm)	Power Output (mW)
1850.20	8.4	27.4	550
1880.00	8.4	28.6	724
1909.80	10.4	25.0	316

Tuned Frequency (MHz)	Power Input (dBm)	Power Output (dBm)	Power Output (mW)
1930.20	-29.0	-9.6	0.11
1960.00	-30.0	-9.3	0.12
1989.80	-29.0	-10.6	0.09

Test Data Table 6 – Output Power – EDGE 1900 – Uplink/Downlink

Tuned Frequency (MHz)	Power Input (dBm)	Power Output (dBm)	Power Output (mW)
1850.20	8.4	26.6	457
1880.00	8.4	28.1	646
1909.80	10.4	24.4	275

Tuned Frequency (MHz)	Power Input (dBm)	Power Output (dBm)	Power Output (mW)
1930.20	-29.0	-9.8	0.1
1960.00	-30.0	-9.5	0.11
1989.80	-29.0	-10.4	0.09

Test Data Table 7 – Output Power – CDMA 1700 – Uplink/Downlink

Tuned Frequency (MHz)	Power Input (dBm)	Power Output (dBm)	Power Output (mW)
1711.25	8.4	26.5	447
1732.50	9.4	25.0	316
1753.75	11.4	26.0	398

Tuned Frequency (MHz)	Power Input (dBm)	Power Output (dBm)	Power Output (mW)
2111.25	-29.0	-9.1	0.12
2132.50	-29.0	-9.5	0.11
2153.75	-27.0	-9.9	0.1

Test Data Table 8 – Output Power – EVDO 1700 – Uplink/Downlink

Tuned Frequency (MHz)	Power Input (dBm)	Power Output (dBm)	Power Output (mW)
1711.25	8.4	26.3	427
1732.50	9.4	24.4	275
1753.75	8.4	23.3	214

Tuned Frequency (MHz)	Power Input (dBm)	Power Output (dBm)	Power Output (mW)
2111.25	-28.0	-8.6	0.14
2132.50	-27.0	-8.7	0.13
2153.75	-28.0	-11.0	0.08

Test Data Table 9 – Output Power – HSPA 1700 – Uplink/Downlink

Tuned Frequency (MHz)	Power Input (dBm)	Power Output (dBm)	Power Output (mW)
1712.50	4.4	23.2	209
1732.50	6.4	21.6	145
1752.50	6.4	22.6	182

Tuned Frequency (MHz)	Power Input (dBm)	Power Output (dBm)	Power Output (mW)
2112.50	-25.0	-6.4	0.23
2132.50	-25.0	-7.6	0.17
2152.50	-25.0	-9.2	0.12

[Continued]



Test Data Table 10 – Output Power – LTE 1700 – Uplink/Downlink

Tuned Frequency (MHz)	Power Input (dBm)	Power Output (dBm)	Power Output (mW)
1715.00	5.4	23.6	229
1732.50	7.4	22.2	166
1750.00	6.4	23.1	204

Tuned Frequency (MHz)	Power Input (dBm)	Power Output (dBm)	Power Output (mW)
2115.00	-27.0	-7.4	0.18
2132.50	-26.0	-7.8	0.17
2150.00	-26.0	-7.9	0.16

Test Data Table 11 – Output Power – GSM 1700 – Uplink/Downlink

Tuned Frequency (MHz)	Power Input (dBm)	Power Output (dBm)	Power Output (mW)
1710.20	8.4	26.3	427
1732.50	8.4	23.0	200
1754.80	8.4	22.5	178

Tuned Frequency (MHz)	Power Input (dBm)	Power Output (dBm)	Power Output (mW)
2110.20	-29.0	-9.3	0.12
2132.50	-29.0	-10.4	0.09
2154.80	-28.0	-11.9	0.06

Test Data Table 12 – Output Power – EDGE 1700 – Uplink/Downlink

Tuned Frequency (MHz)	Power Input (dBm)	Power Output (dBm)	Power Output (mW)
1710.20	8.4	26.1	407
1732.50	8.4	22.8	191
1754.80	8.4	22.5	178

Tuned Frequency (MHz)	Power Input (dBm)	Power Output (dBm)	Power Output (mW)
2110.20	-28.0	-8.7	0.13
2132.50	-27.0	-8.8	0.13
2154.80	-28.0	-12.0	0.06

Test Data Table 13 – Output Power – CDMA 800 – Uplink/Downlink

Tuned Frequency (MHz)	Power Input (dBm)	Power Output (dBm)	Power Output (mW)
825.25	7.4	28.3	676
836.50	7.4	29.2	832
847.75	7.4	27.8	603

Tuned Frequency (MHz)	Power Input (dBm)	Power Output (dBm)	Power Output (mW)
870.25	-30.0	-10.4	0.09
881.50	-30.0	-9.7	0.11
892.75	-30.0	-10.8	0.08

Test Data Table 14 – Output Power – EVDO 800 – Uplink/Downlink

Tuned Frequency (MHz)	Power Input (dBm)	Power Output (dBm)	Power Output (mW)
825.25	7.4	28.3	676
836.50	7.4	29.1	813
847.75	7.4	27.8	603

Tuned Frequency (MHz)	Power Input (dBm)	Power Output (dBm)	Power Output (mW)
870.25	-30.0	-10.4	0.09
881.50	-30.0	-9.6	0.11
892.75	-30.0	-10.9	0.08

[Continued]

Test Data Table 15 – Output Power – HSPA 800 – Uplink/Downlink

Tuned Frequency (MHz)	Power Input (dBm)	Power Output (dBm)	Power Output (mW)
826.50	5.4	27.6	575
836.50	5.4	28.4	692
846.50	5.4	27.1	513

Tuned Frequency (MHz)	Power Input (dBm)	Power Output (dBm)	Power Output (mW)
871.50	-30.0	-9.7	0.11
881.50	-30.0	-9.5	0.11
891.50	-30.0	-10.1	0.1

Test Data Table 16 – Output Power – LTE 800 – Uplink/Downlink

Tuned Frequency (MHz)	Power Input (dBm)	Power Output (dBm)	Power Output (mW)
829.00	4.4	26.9	490
836.50	5.4	27.7	589
844.00	5.4	26.5	447

Tuned Frequency (MHz)	Power Input (dBm)	Power Output (dBm)	Power Output (mW)
874.00	-30.0	-10.1	0.1
881.50	-30.0	-9.8	0.1
889.00	-30.0	-10.2	0.1

Test Data Table 17 – Output Power – GSM 800 – Uplink/Downlink

Tuned Frequency (MHz)	Power Input (dBm)	Power Output (dBm)	Power Output (mW)
824.20	8.4	28.5	708
836.50	8.4	29.1	813
848.80	8.4	28.1	646

Tuned Frequency (MHz)	Power Input (dBm)	Power Output (dBm)	Power Output (mW)
869.20	-29.0	-9.7	0.11
881.50	-29.0	-9.2	0.12
893.80	-28.0	-9.8	0.1

Test Data Table 18 – Output Power – EDGE 800 – Uplink/Downlink

Tuned Frequency (MHz)	Power Input (dBm)	Power Output (dBm)	Power Output (mW)
824.20	8.4	27.9	617
836.50	8.4	28.8	759
848.80	8.4	27.8	603

Tuned Frequency (MHz)	Power Input (dBm)	Power Output (dBm)	Power Output (mW)
869.20	-29.0	-9.8	0.1
881.50	-29.0	-9.2	0.12
893.80	-28.0	-9.9	0.1



INPUT/OUTPUT MODULATED AMPLITUDE COMPARISON AND BAND-EDGES COMPLIANCE

Rule Parts No.: Pt 2.1049, Pt 2.1051, 22H, 24E, 27

Requirements: The power of any emission outside of the authorized operating frequency ranges must be attenuated below the transmitting power (P) by a factor of at least $43 + 10 \log(P)$ dB.

Test Data: The DUT does meet the requirements.

Bandedge compliance: Measurements were performed in accordance with Part 24.238

The Reference level on the following plots was calibrated using a 3MHz RBW=VBW.

Compensating for RBW (1%) using $10 \log(12.5/3) = 6.2$ dB we get the following amplitudes at the bandedge:

Test Data Table 19 – CDMA 1900 – Uplink/Downlink				
Channel (MHz)	Bandedge Frequency (MHz)	Amplitude bandedge (dBm)	Limit (dBm)	Margin (dB)
1851.25	1849.92	-28.18	-13	15.18
1908.75	1910.04	-33.21	-13	20.21
1931.25	1929.97	-76.32	-13	63.32
1988.75	1990.02	-76.36	-13	63.36

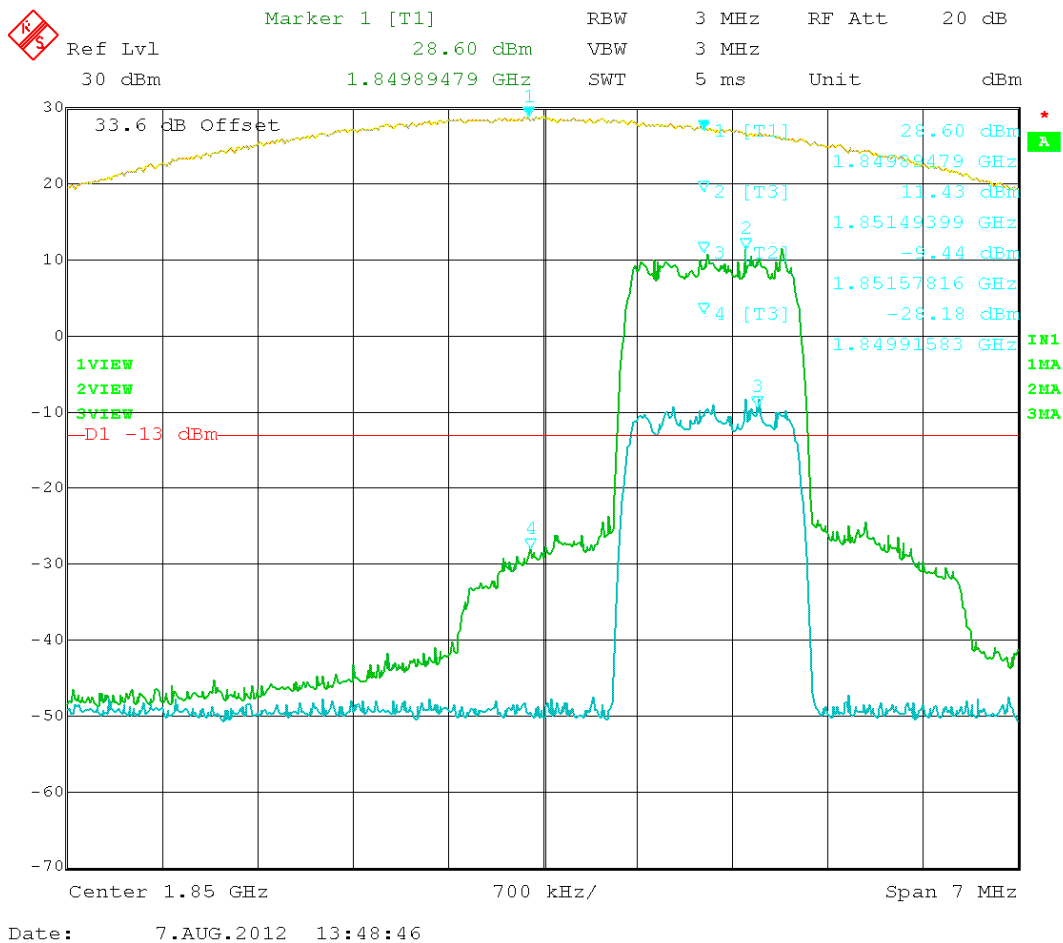

Figure 1: CDMA – In vs. Out 1851.25MHz

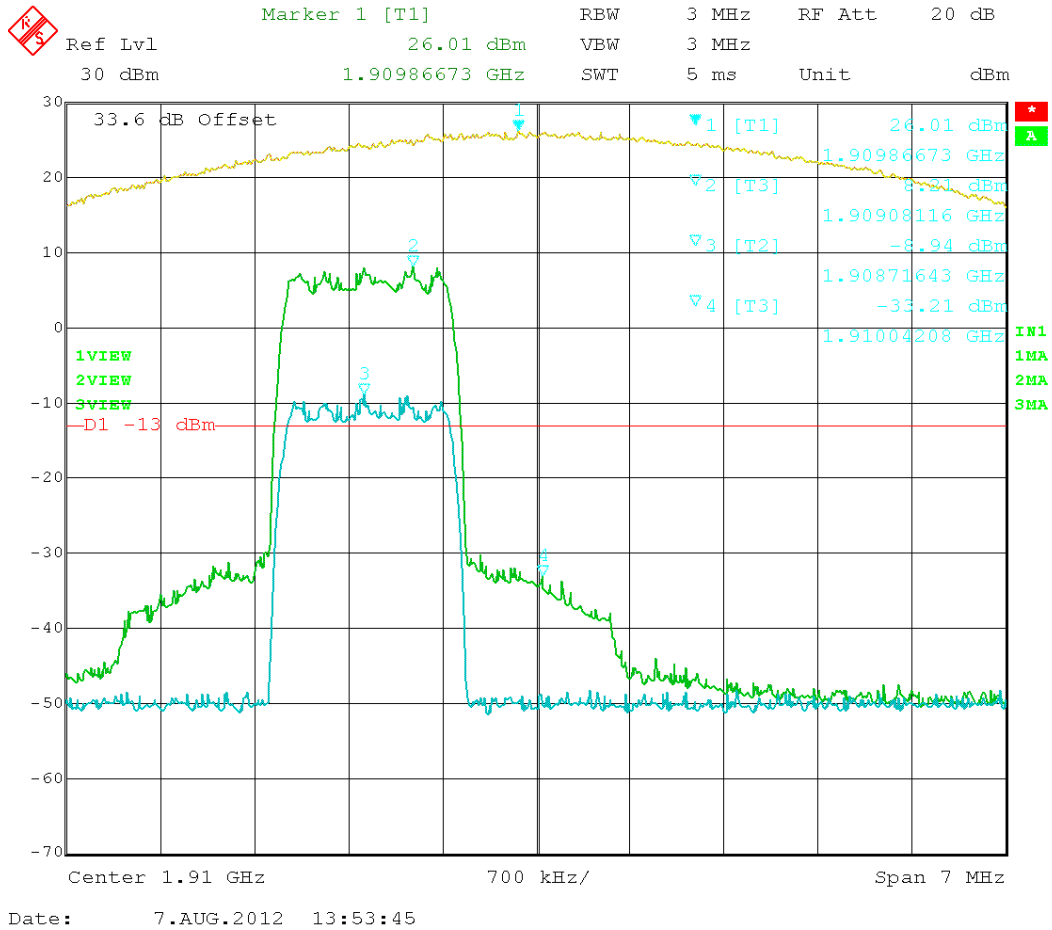

Figure 2: CDMA – In vs. Out 1908.75MHz

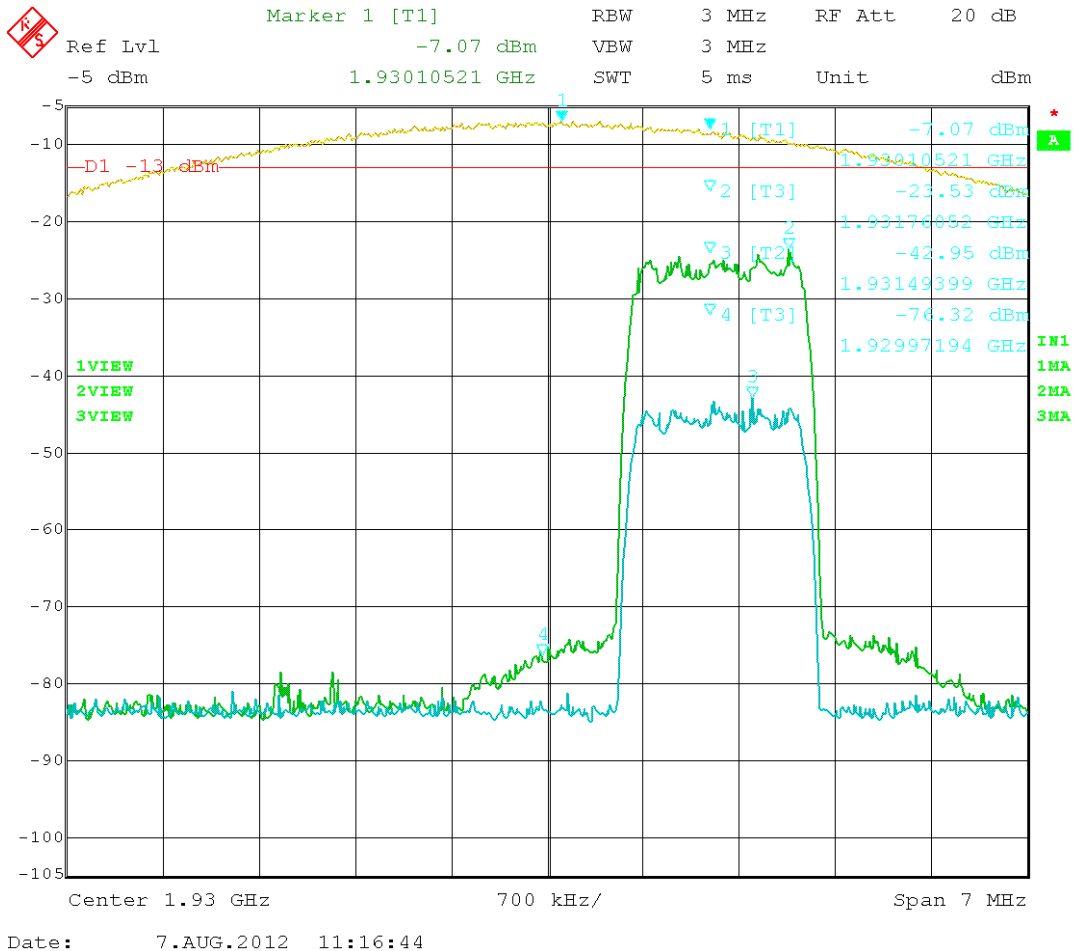

Figure 3: CDMA – In vs. Out 1931.25MHz

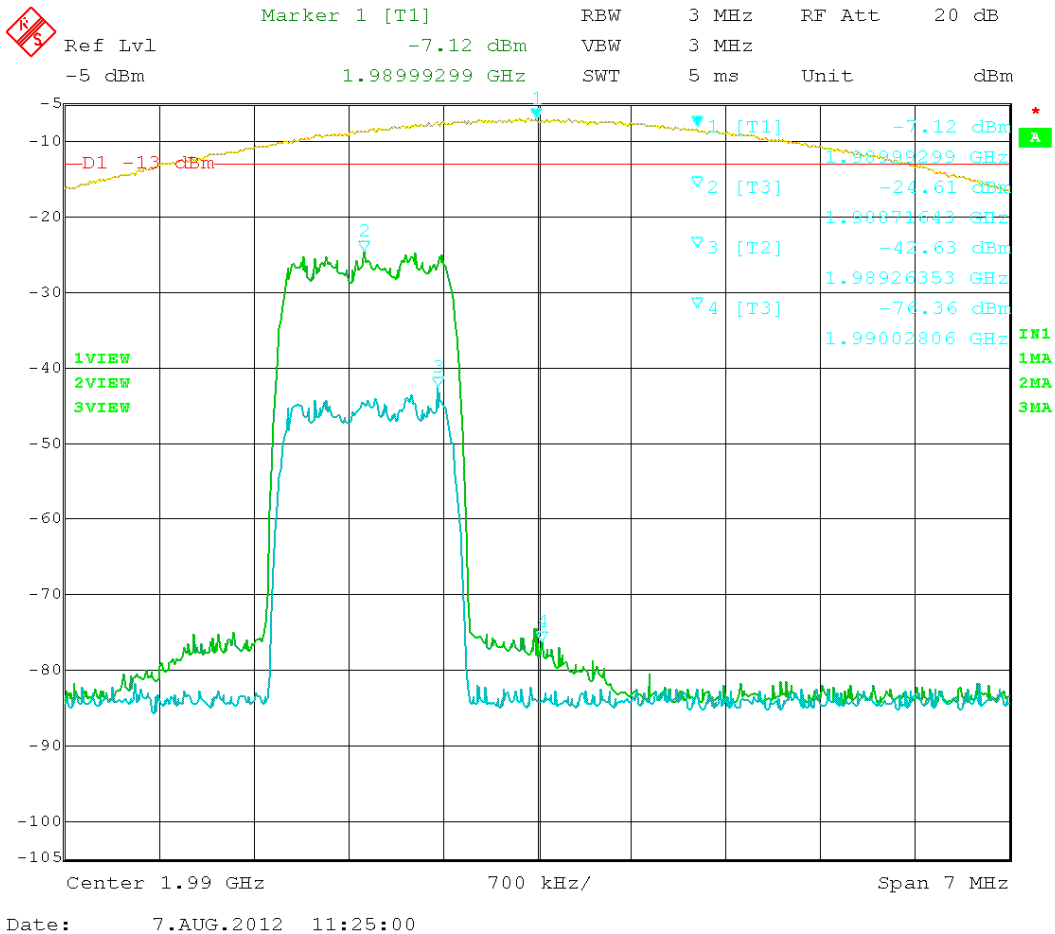

Figure 4: CDMA – In vs. Out 1988.75MHz

Test Data Table 20 – EVDO 1900 – Uplink/Downlink

Channel (MHz)	Bandedge Frequency (MHz)	Amplitude bandedge (dBm)	Limit (dBm)	Margin (dB)
1851.25	1849.94	-29.65	-13	16.65
1908.75	1910.04	-32.06	-13	19.06
1931.25	1929.97	-81.18	-13	68.18
1988.75	1990.14	-80.6	-13	67.6

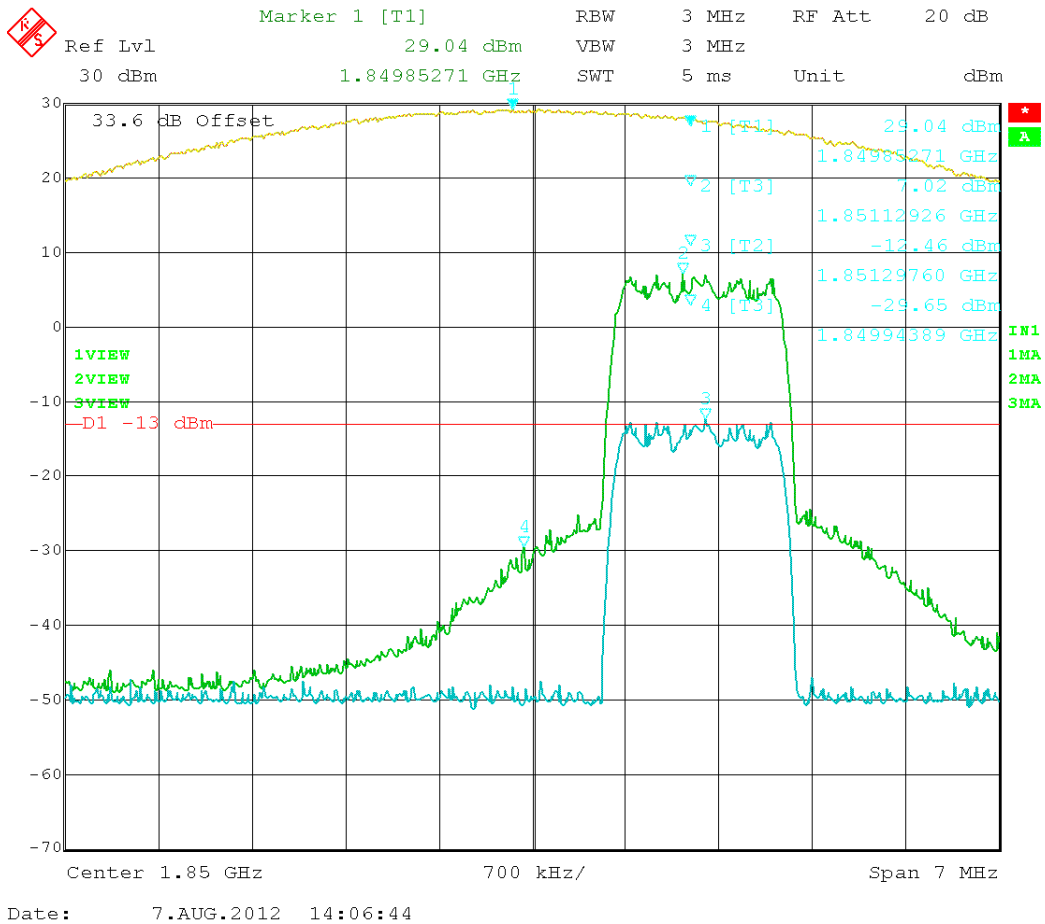

Figure 5: EVDO – In vs. Out 1851.25MHz

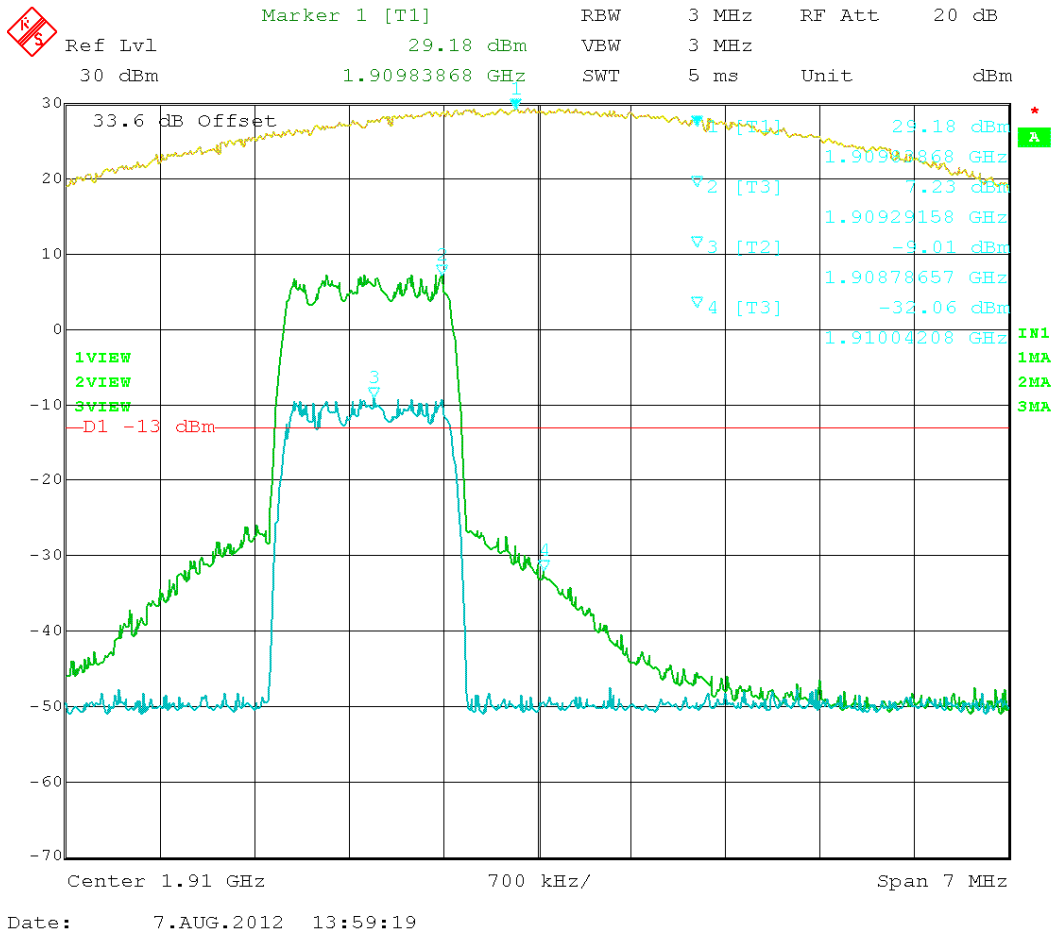

Figure 6: EVDO – In vs. Out 1908.75MHz

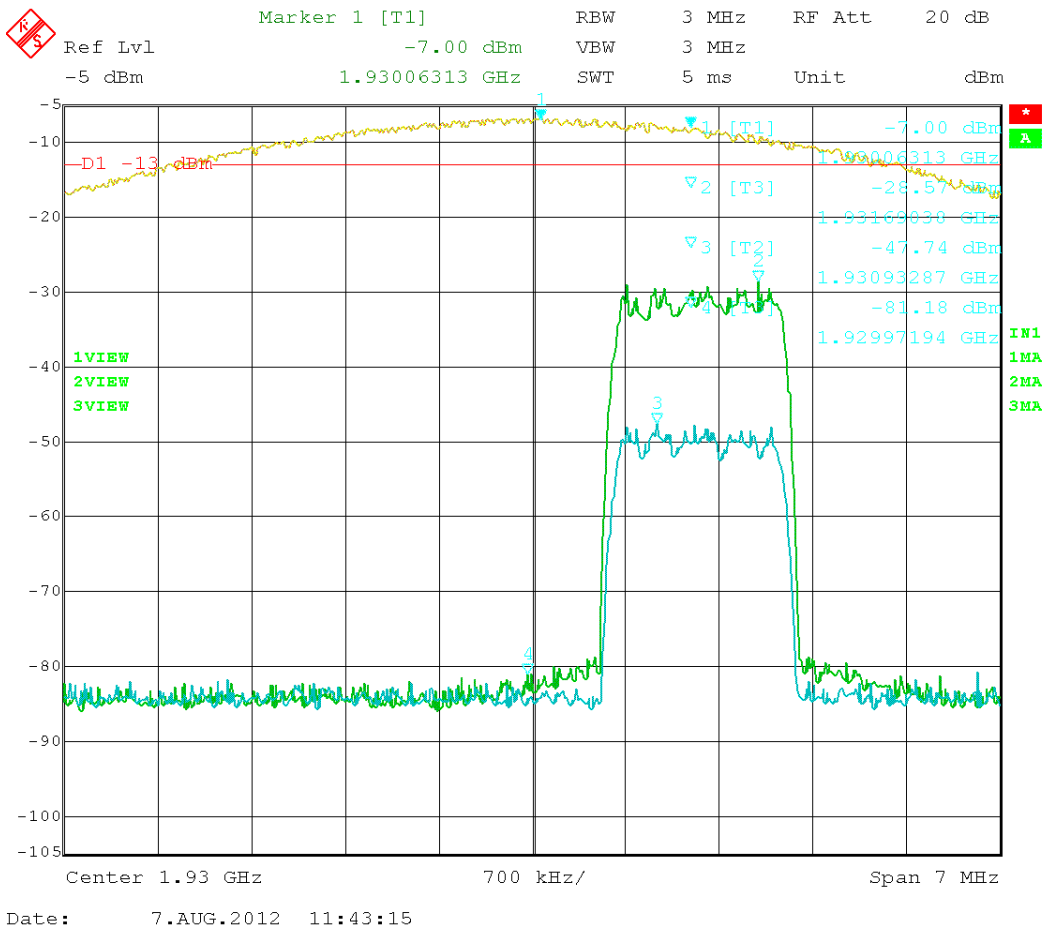

Figure 7: EVDO – In vs. Out 1931.25MHz

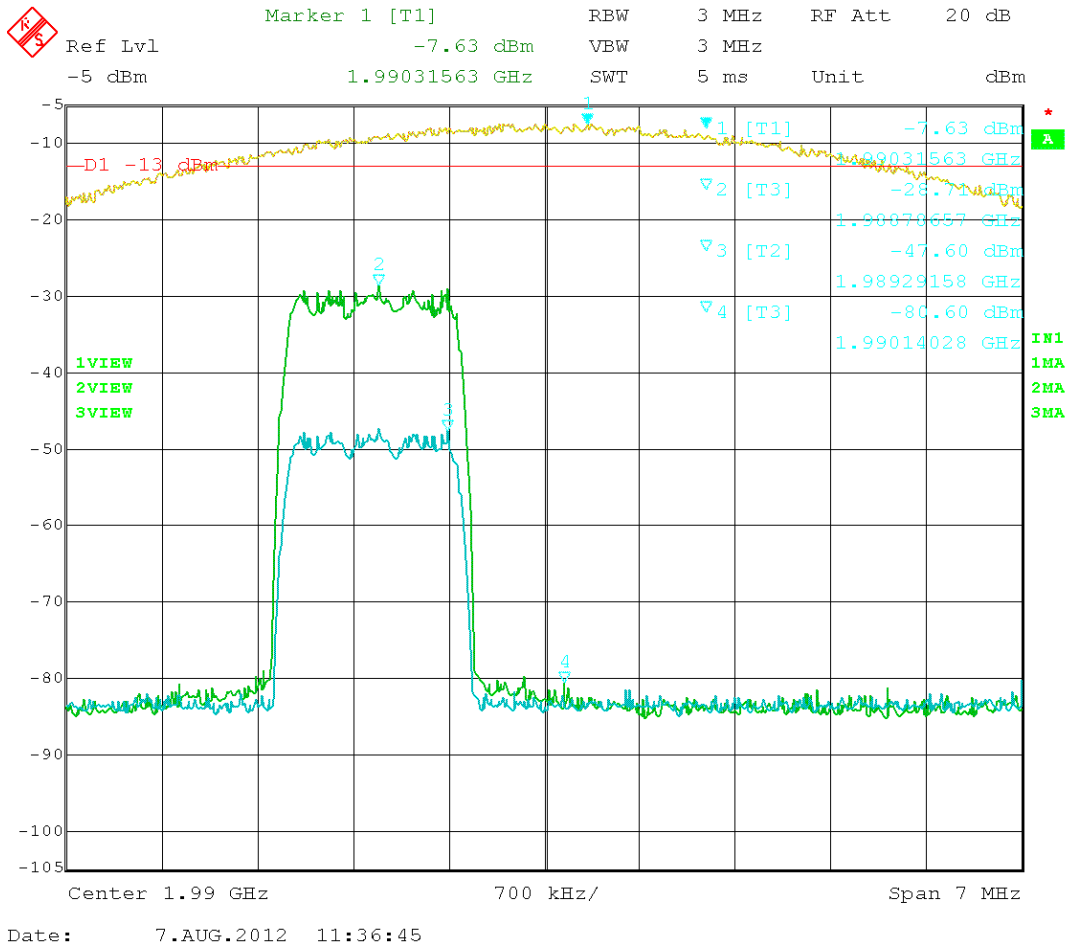

Figure 8: EVDO – In vs. Out 1988.75MHz

Test Data Table 21 – HSPA 1900 – Uplink/Downlink

Channel (MHz)	Bandedge Frequency (MHz)	Amplitude bandedge (dBm)	Limit (dBm)	Margin (dB)
1852.5	1849.79	-25.25	-13	12.25
1907.5	1910.24	-26.67	-13	13.67
1932.5	1928.44	-80.47	-13	67.47
1987.5	1990.72	-79.84	-13	66.84

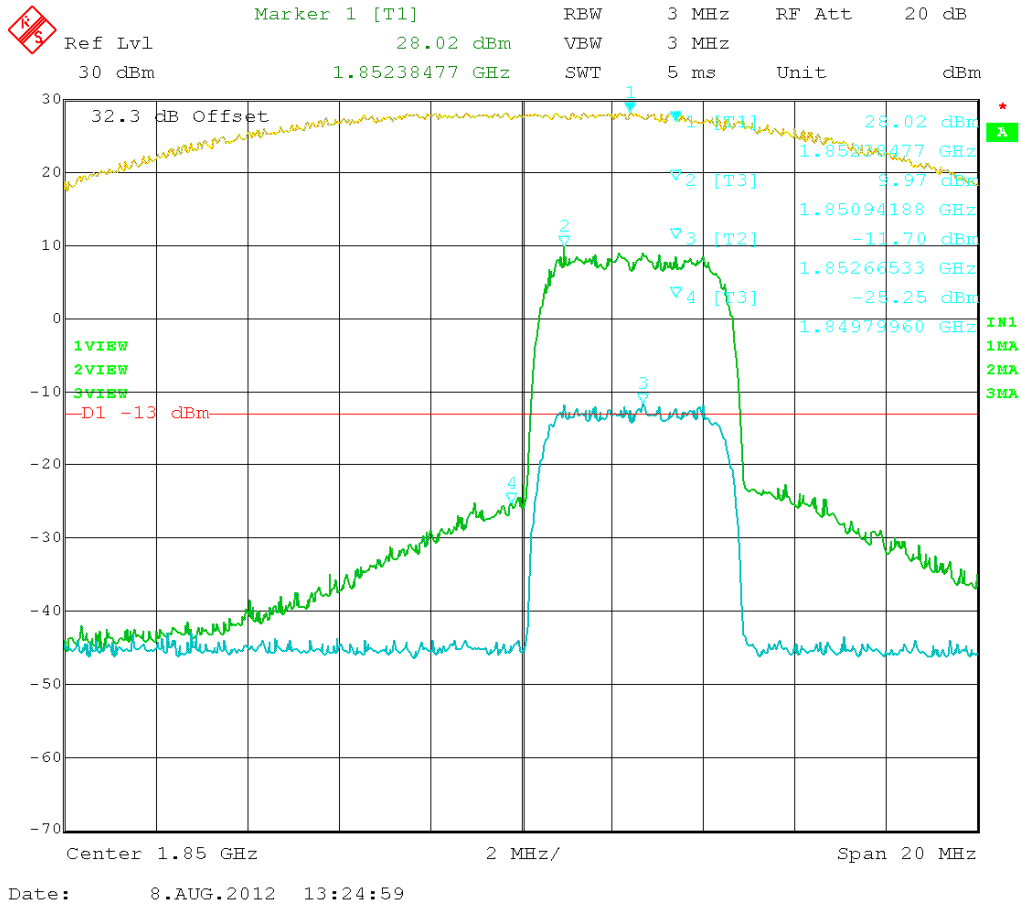
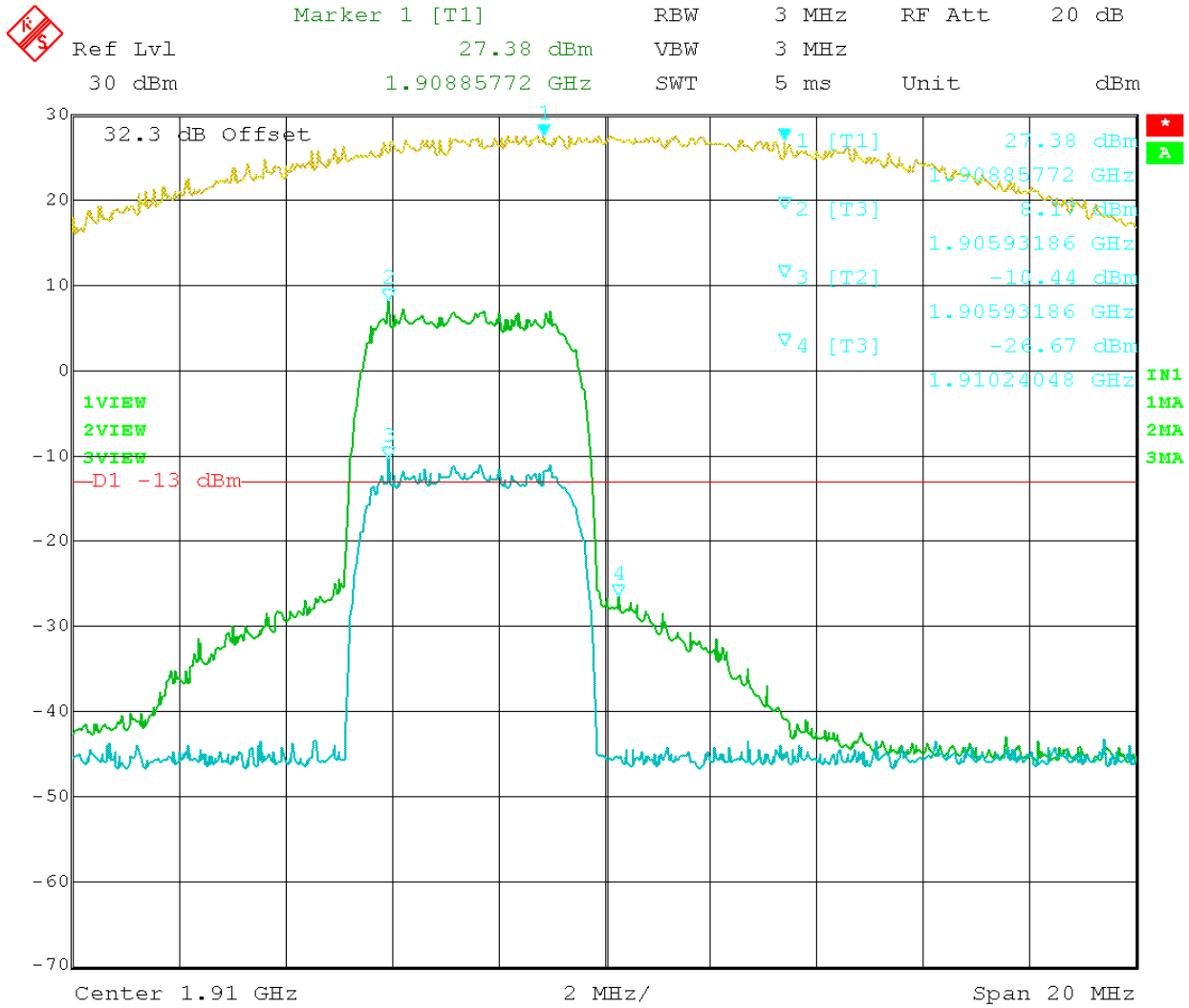

Figure 9: HSPA – In vs. Out 1852.50 MHz



Date: 8.AUG.2012 13:30:50

Figure 10: HSPA – In vs. Out 1907.50 MHz

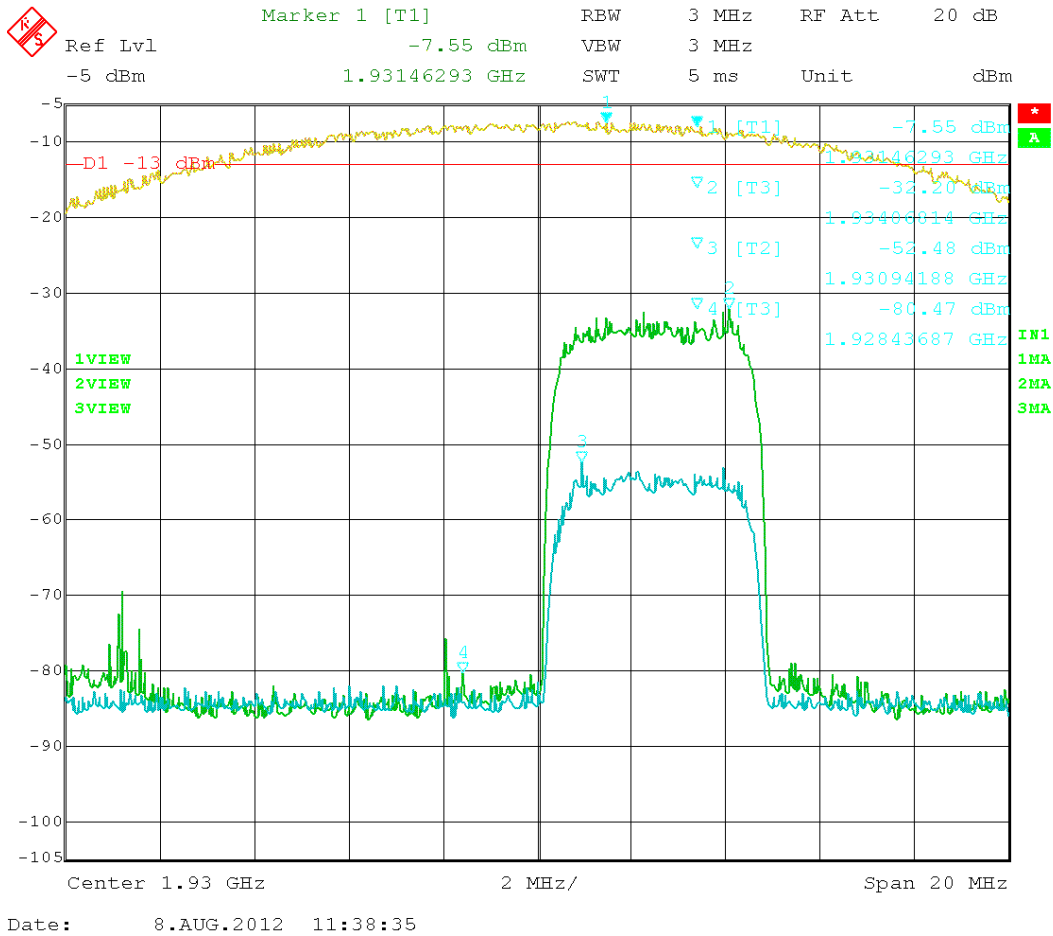

Figure 11: HSPA – In vs. Out 1932.50 MHz

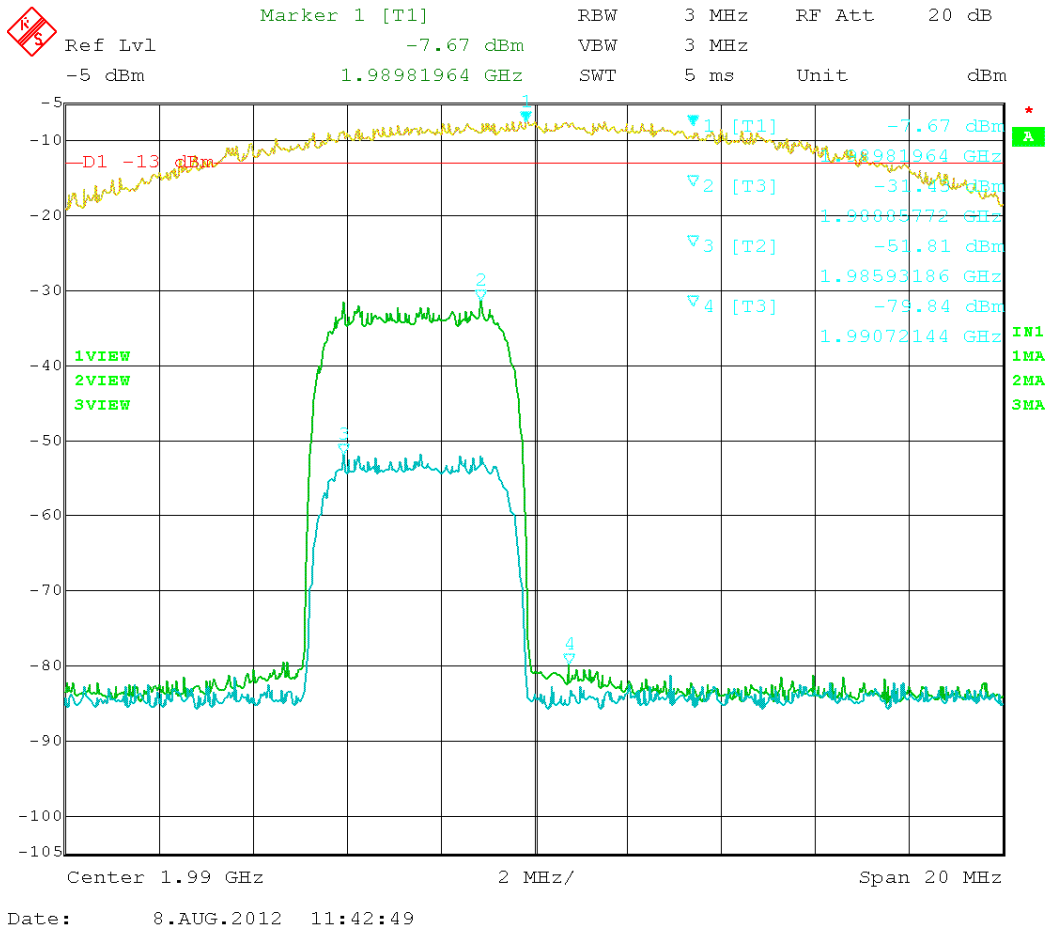

Figure 12: HSPA – In vs. Out 1987.50 MHz

Test Data Table 22 – LTE 1900 – Uplink/Downlink

Channel (MHz)	Band-edge Frequency (MHz)	Amplitude level at the band-edge (dBm)	Limit (dBm)	Margin (dB)
1855.0	1849.59	-25.38	-13	12.38
1905.0	1910.4	-29.06	-13	16.06
1935.0	1929.76	-75.40	-13	62.4
1985.0	1991.84	-74.36	-13	61.36

The Reference level on the following plots was calibrated using a 3MHz RBW=VBW.

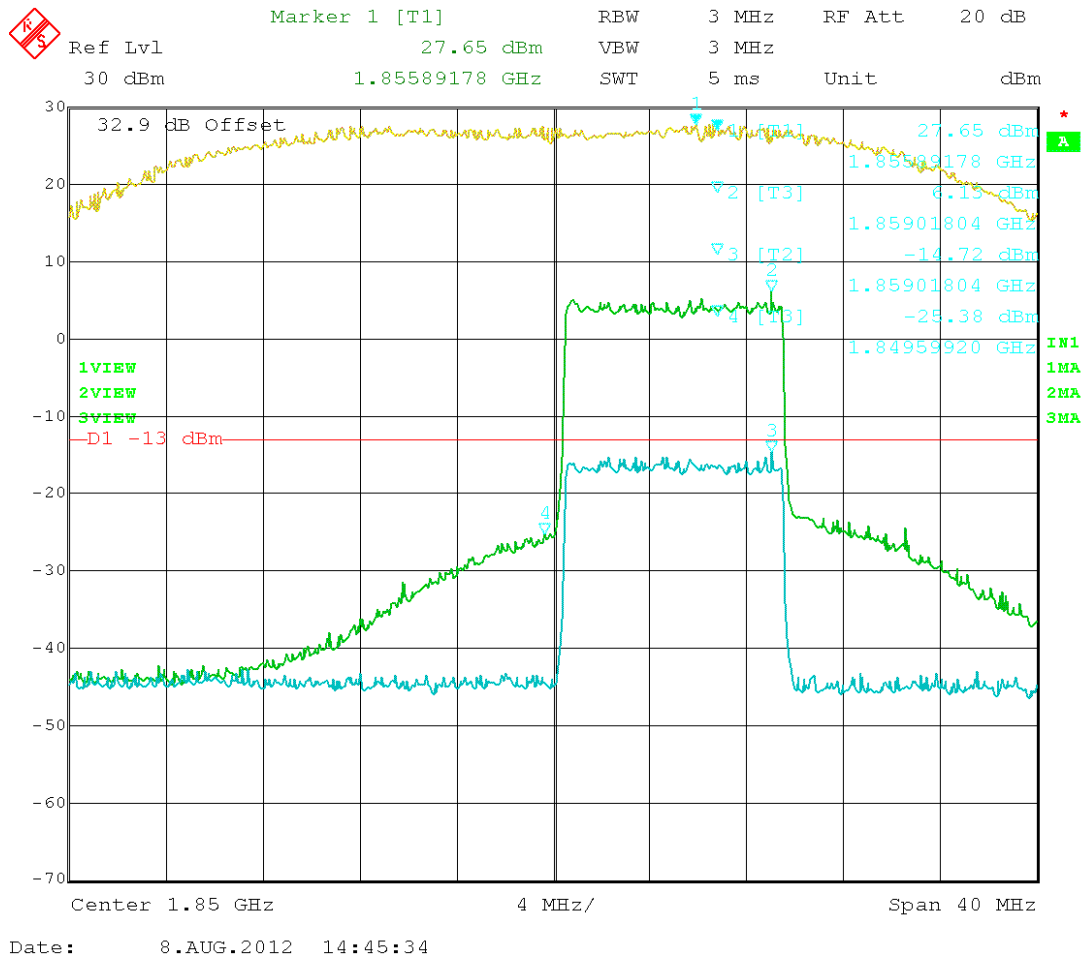

Figure 13: LTE – In vs. Out 1855.00MHz

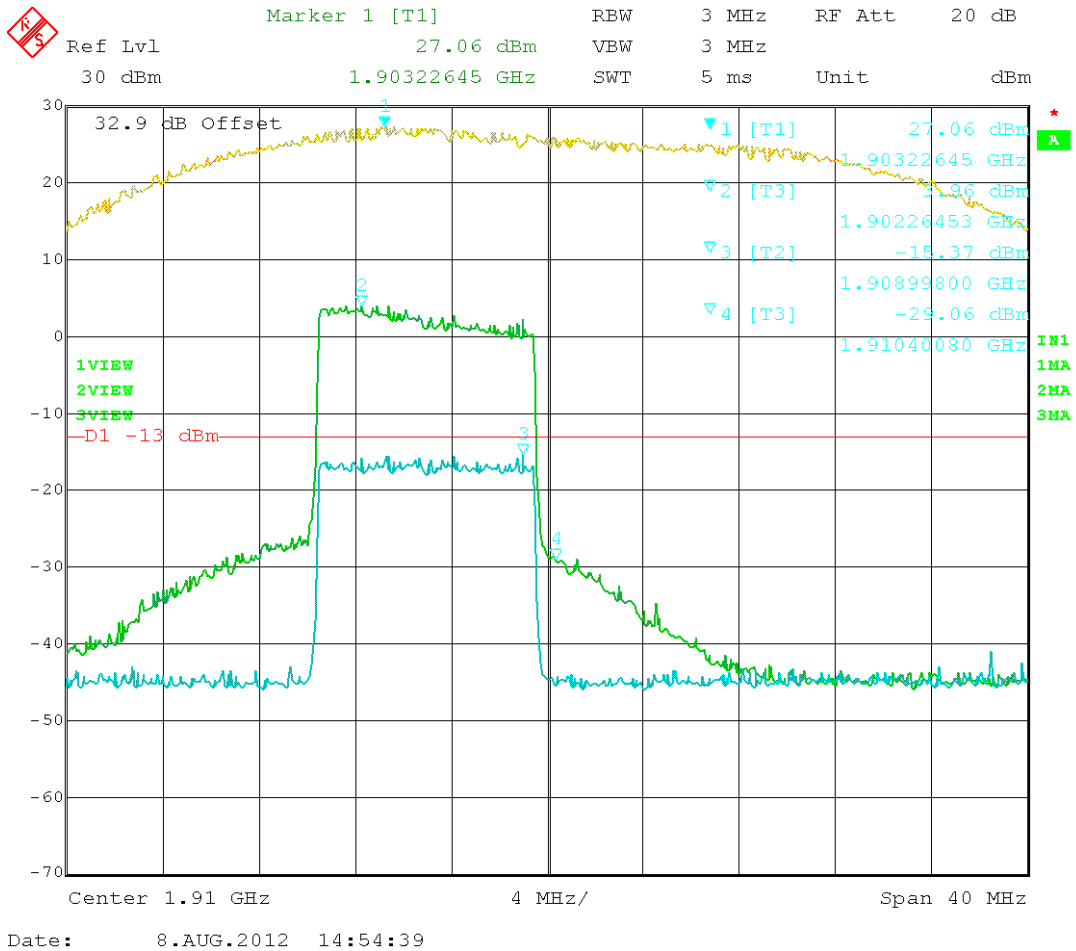

Figure 14: LTE – In vs. Out 1905.00MHz

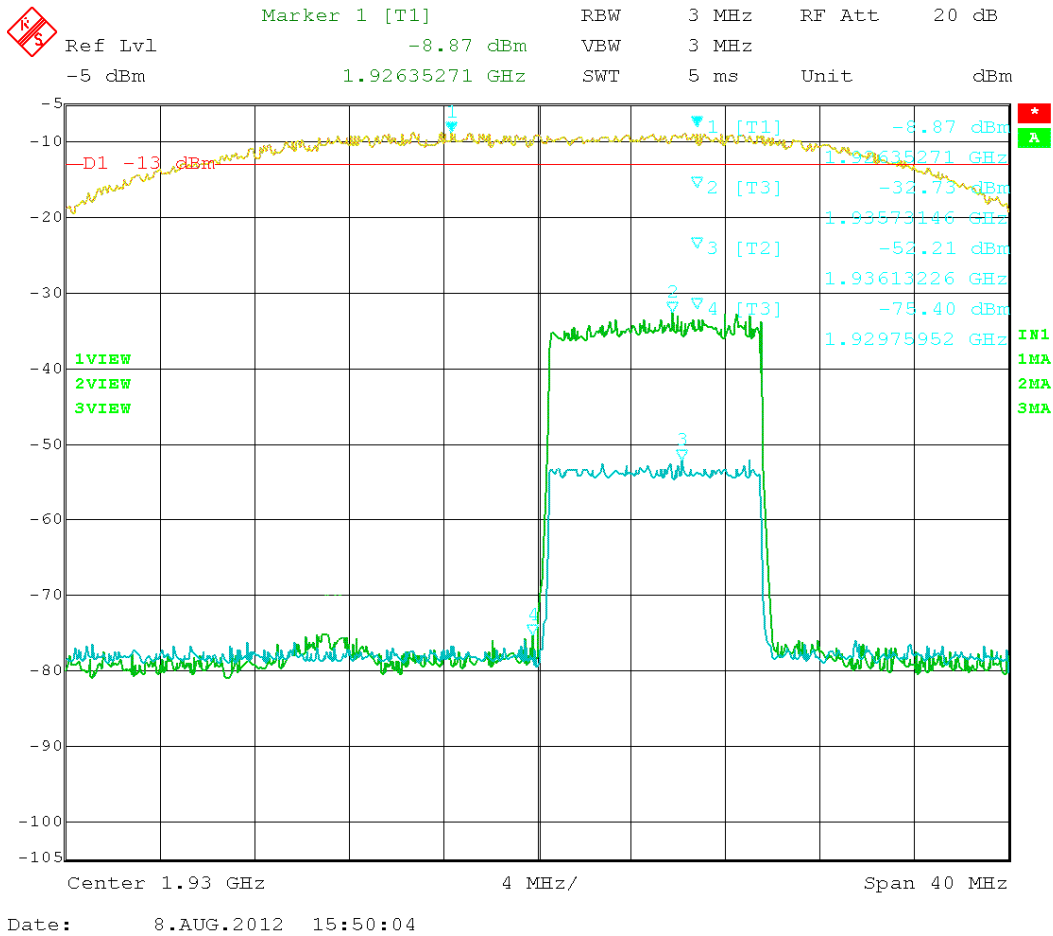

Figure 15: LTE – In vs. Out 1935.00MHz

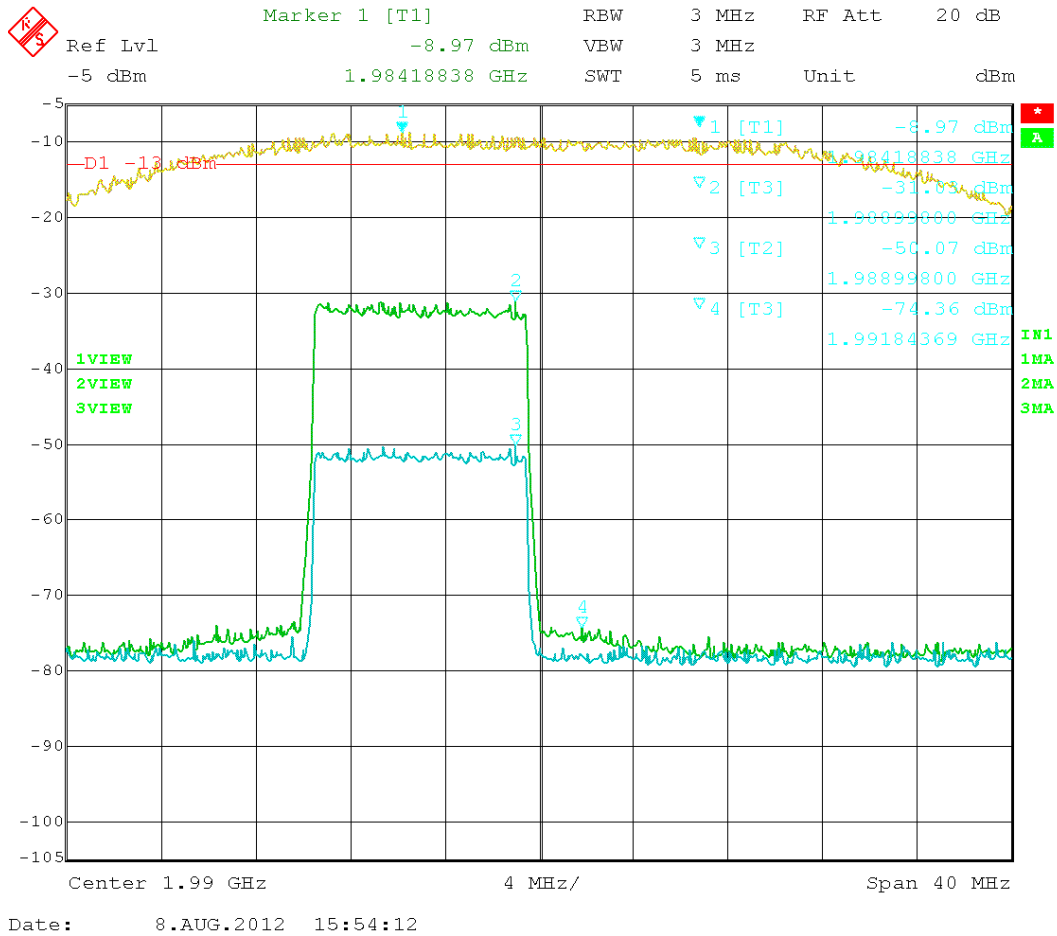

Figure 16: LTE – In vs. Out 1985.00MHz

Test Data Table 23 –GSM 1900 – Uplink/Downlink

Channel (MHz)	Band-edge Frequency (MHz)	Amplitude level at the band-edge (dBm)	Limit (dBm)	Margin (dB)
1850.2	1849.98	-18.95	-13	5.95
1909.8	1910.02	-21.76	-13	8.76
1930.2	1929.98	-52.73	-13	39.73
1989.8	1990.02	-53.72	-13	40.72

The Reference level on the following plots was calibrated using a 3MHz RBW=VBW.

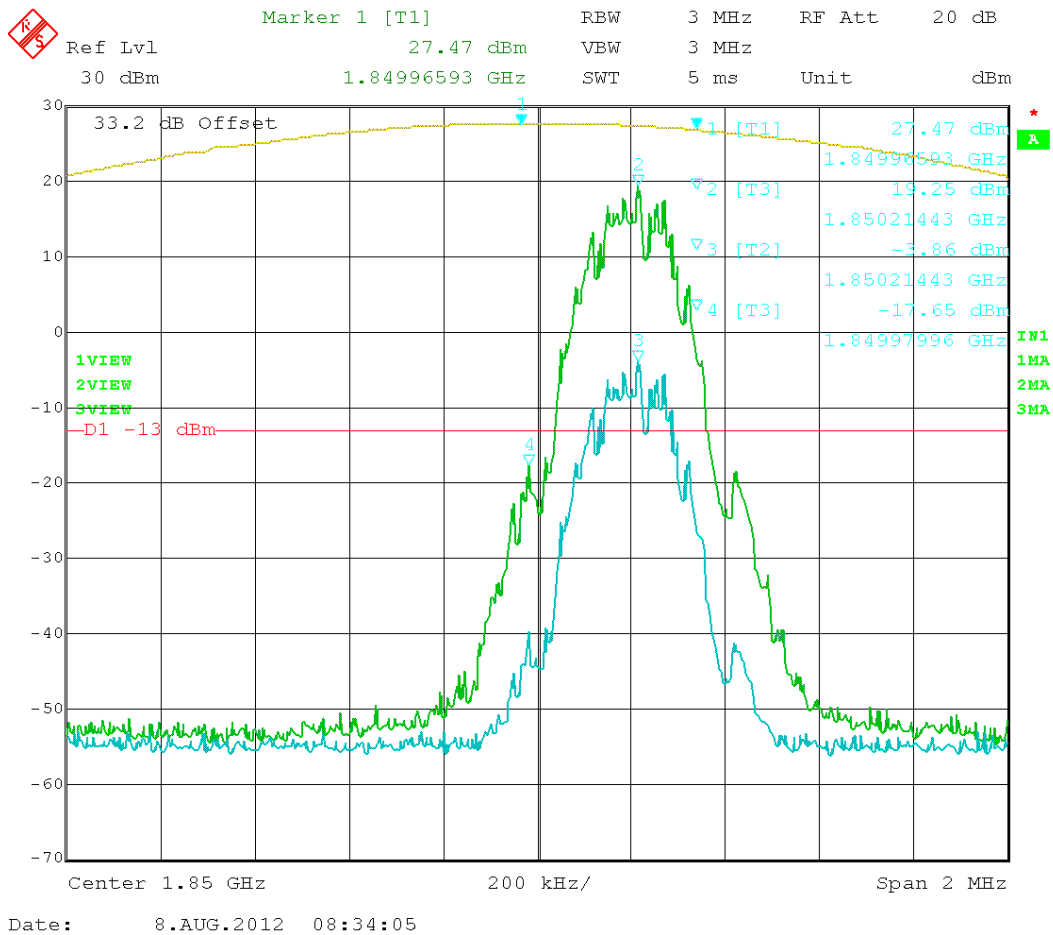

Figure 17: GSM – In vs. Out 1850.20MHz

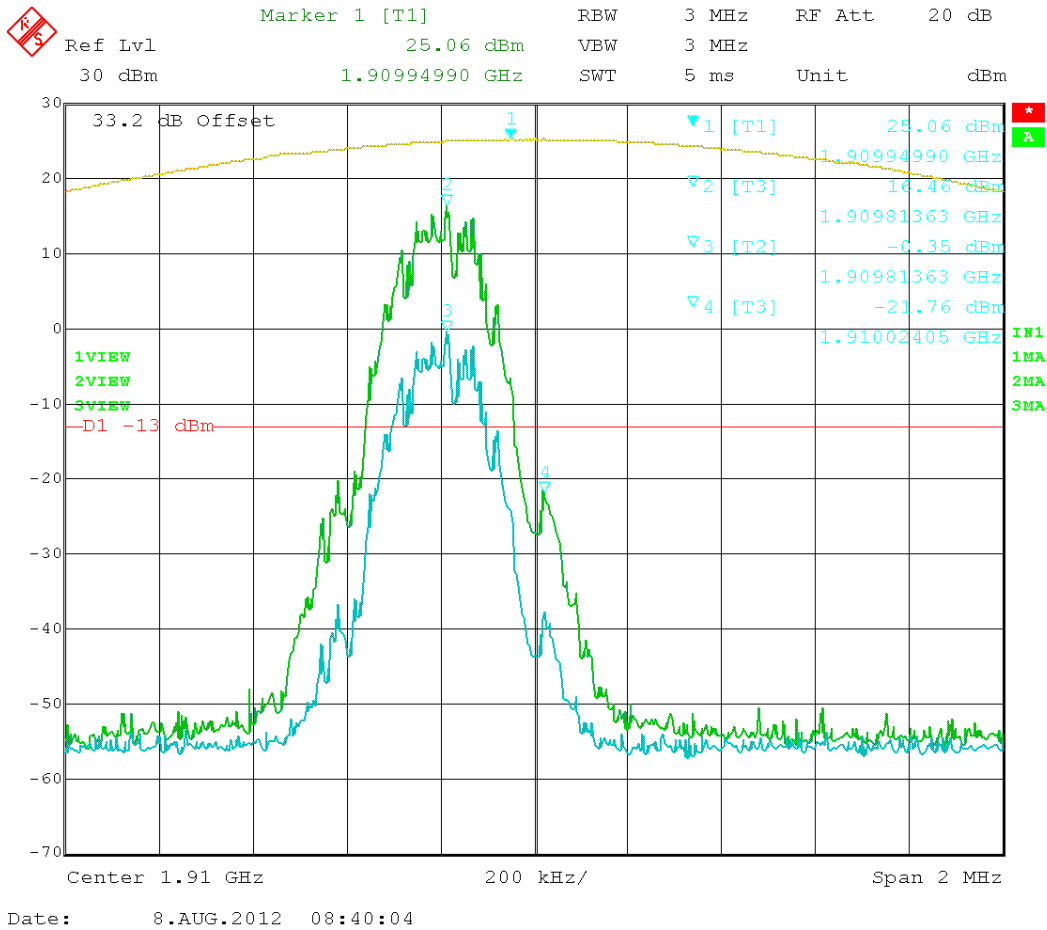

Figure 18: GSM – In vs. Out 1909.80MHz

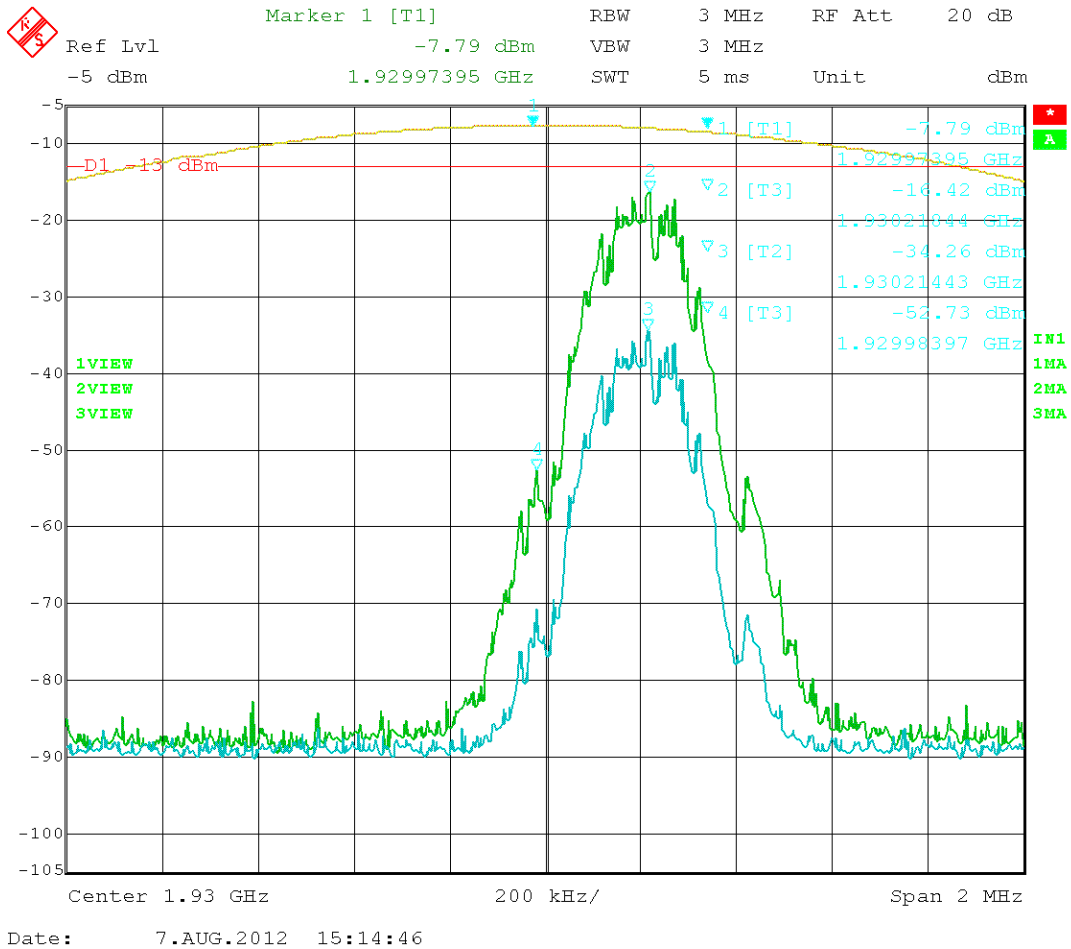

Figure 19: GSM – In vs. Out 1930.20MHz

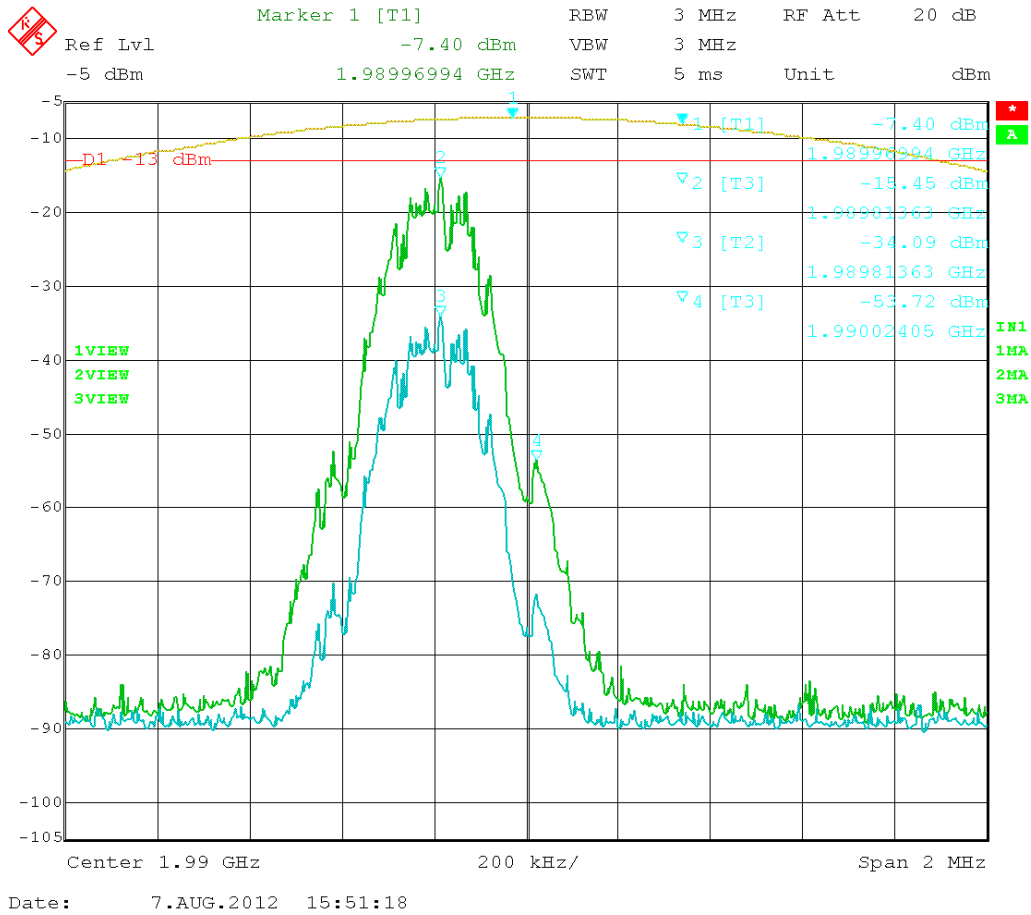

Figure 20: GSM – In vs. Out 1989.80MHz

Test Data Table 24 – EDGE 1900 – Uplink/Downlink

Channel (MHz)	Band-edge Frequency (MHz)	Amplitude level at the band-edge (dBm)	Limit (dBm)	Margin (dB)
1850.2	1849.98	-17.71	-13	4.71
1909.8	1910.02	-19.97	-13	6.97
1930.2	1929.98	-56.02	-13	43.02
1989.8	1990.02	-58.79	-13	45.79

The Reference level on the following plots was calibrated using a 3MHz RBW=VBW.

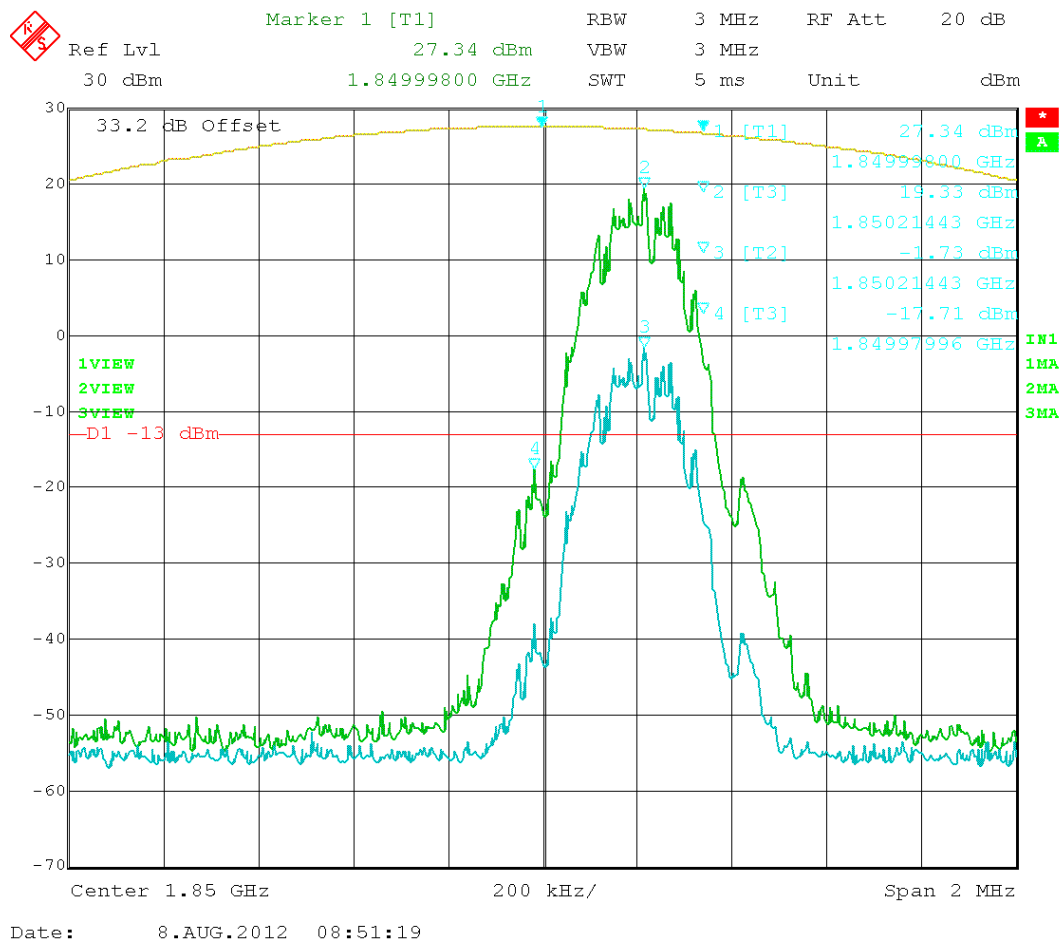

Figure 21: EDGE – In vs. Out 1850.20MHz

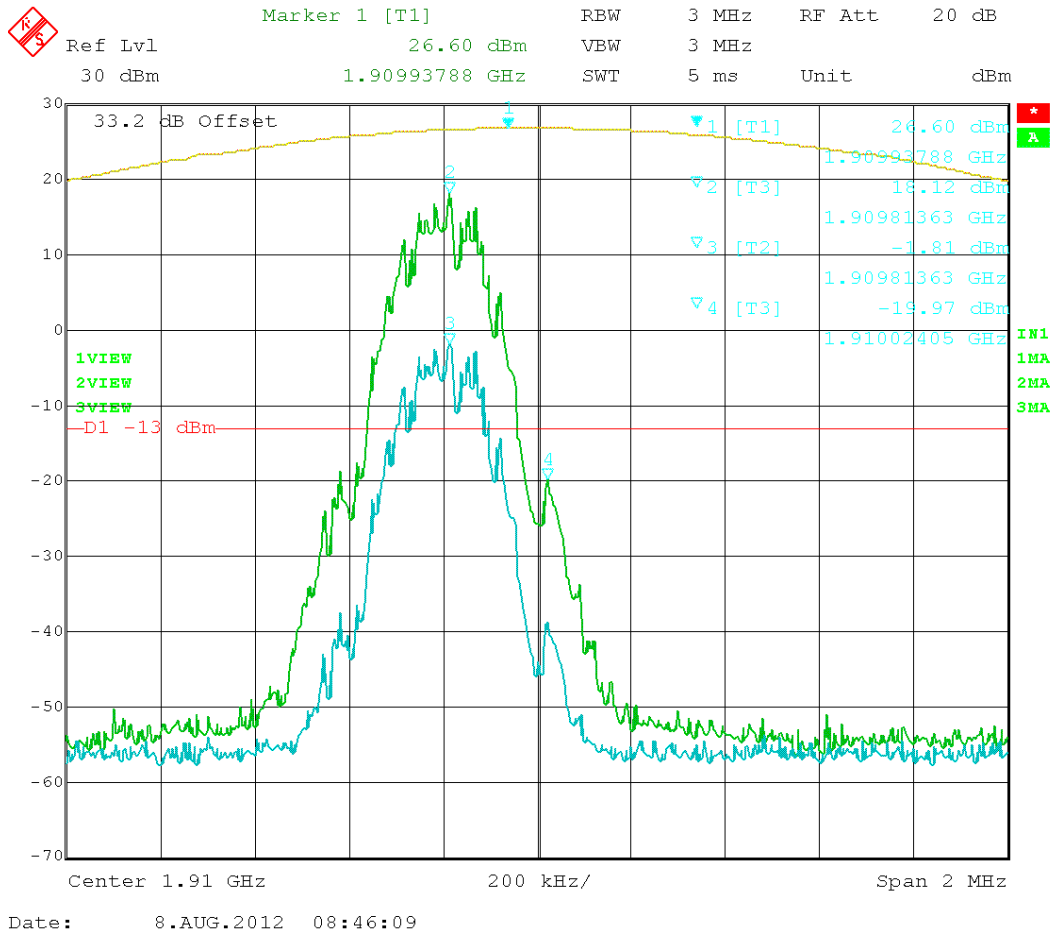

Figure 22: EDGE – In vs. Out 1909.80MHz

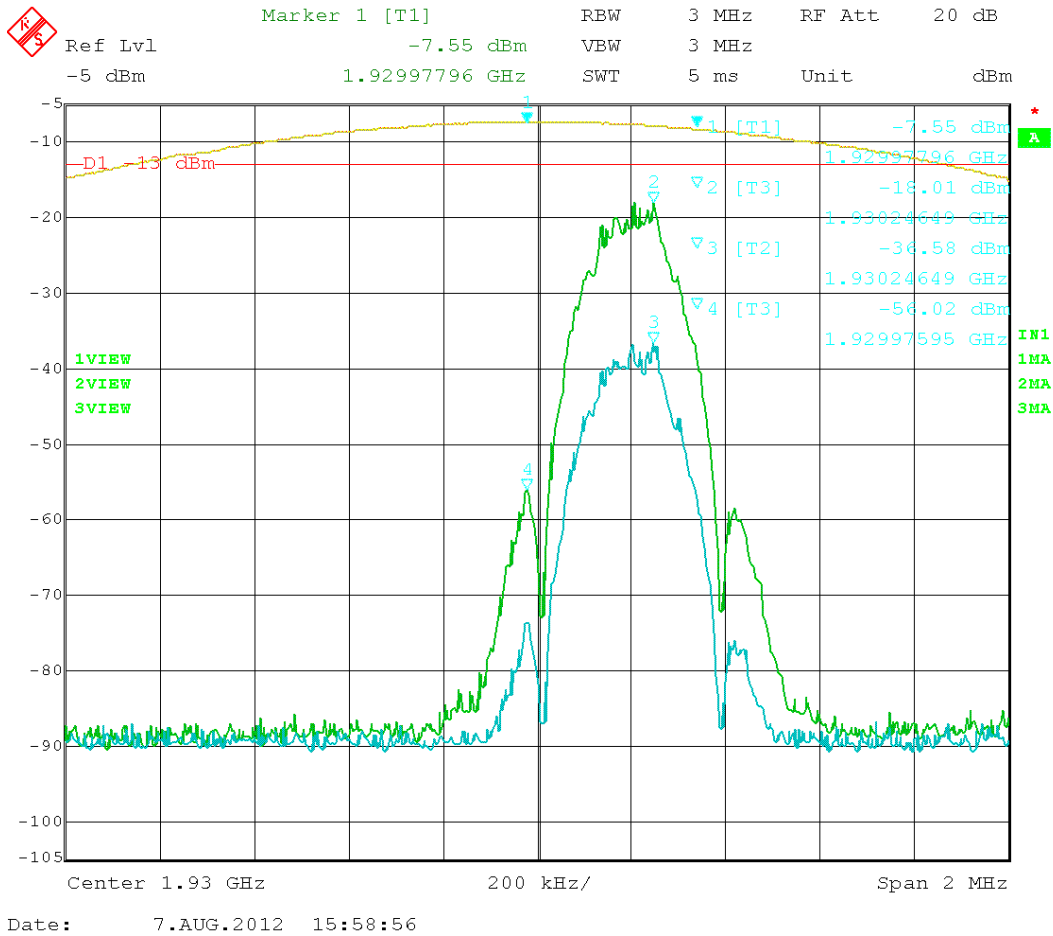

Figure 23: EDGE – In vs. Out 1930.20MHz

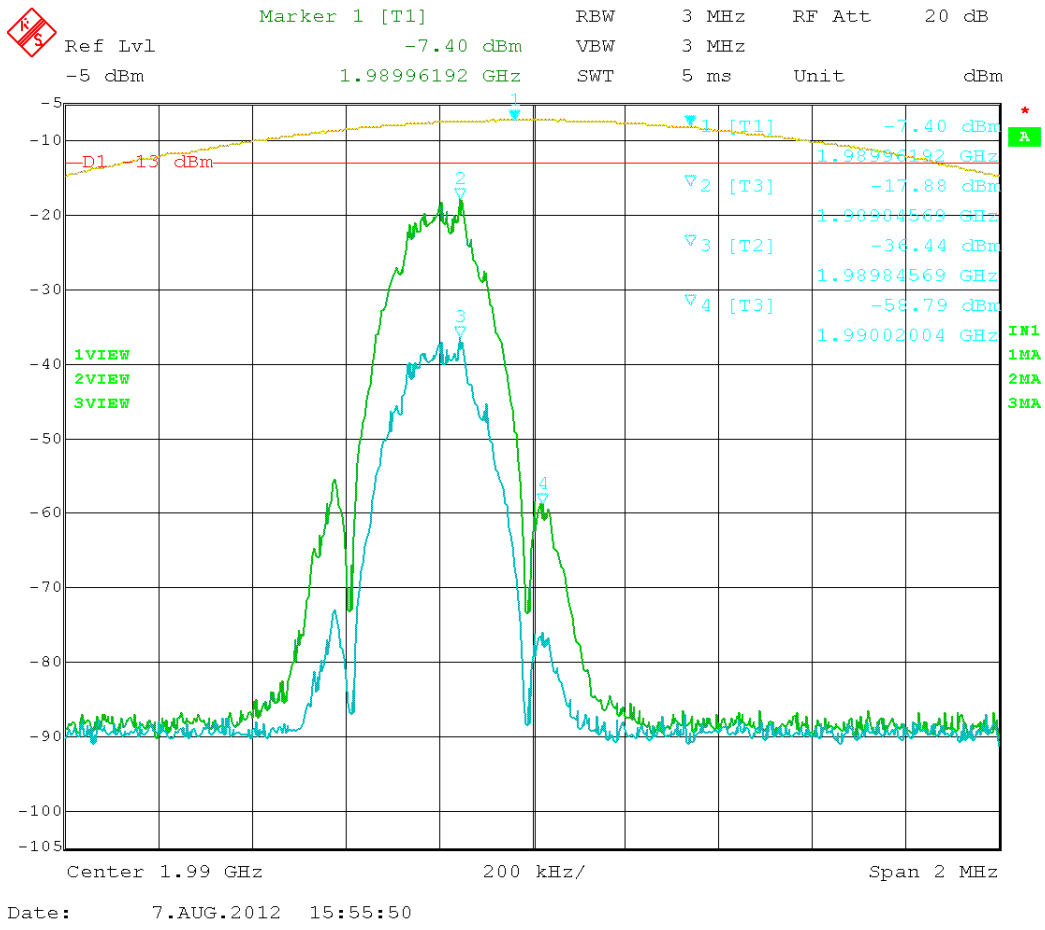

Figure 24: EDGE – In vs. Out 1989.80MHz

Test Data Table 25 – CDMA 1700 – Uplink/Downlink

Channel (MHz)	Bandedge Frequency (MHz)	Amplitude bandedge (dBm)	Limit (dBm)	Margin (dB)
1711.25	1709.91	-34.24	-13	21.24
1753.75	1755.13	-34.19	-13	21.19
2111.25	2109.94	-77.13	-13	64.13
2153.75	2155.03	-77.88	-13	64.88

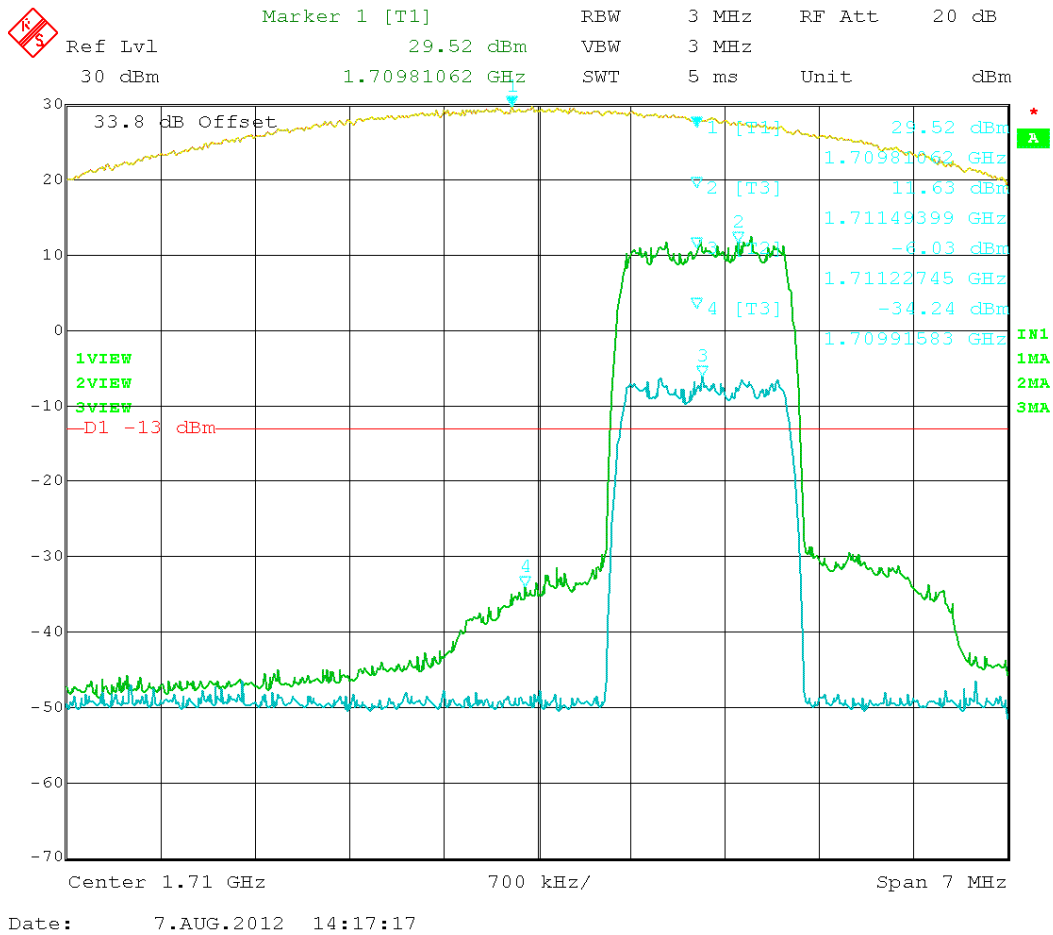

Figure 25: CDMA – In vs. Out 1711.25MHz

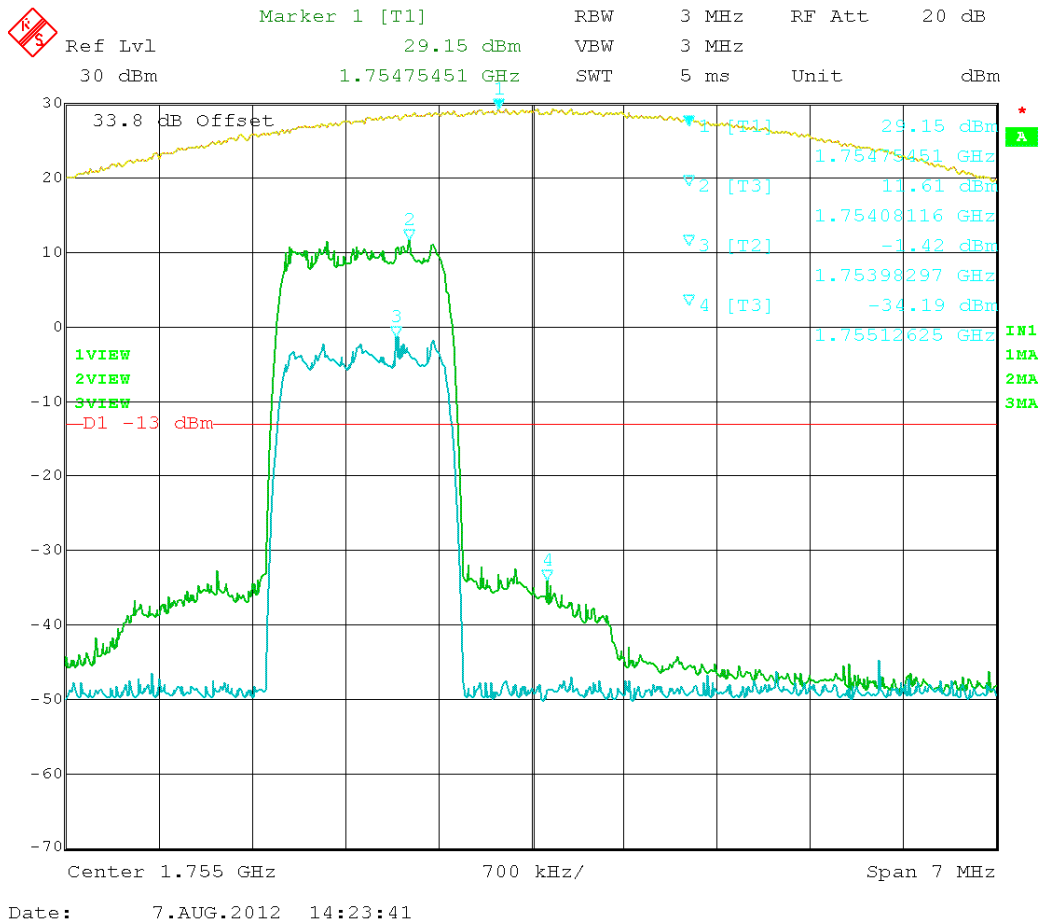

Figure 26: CDMA – In vs. Out 1.755 GHz

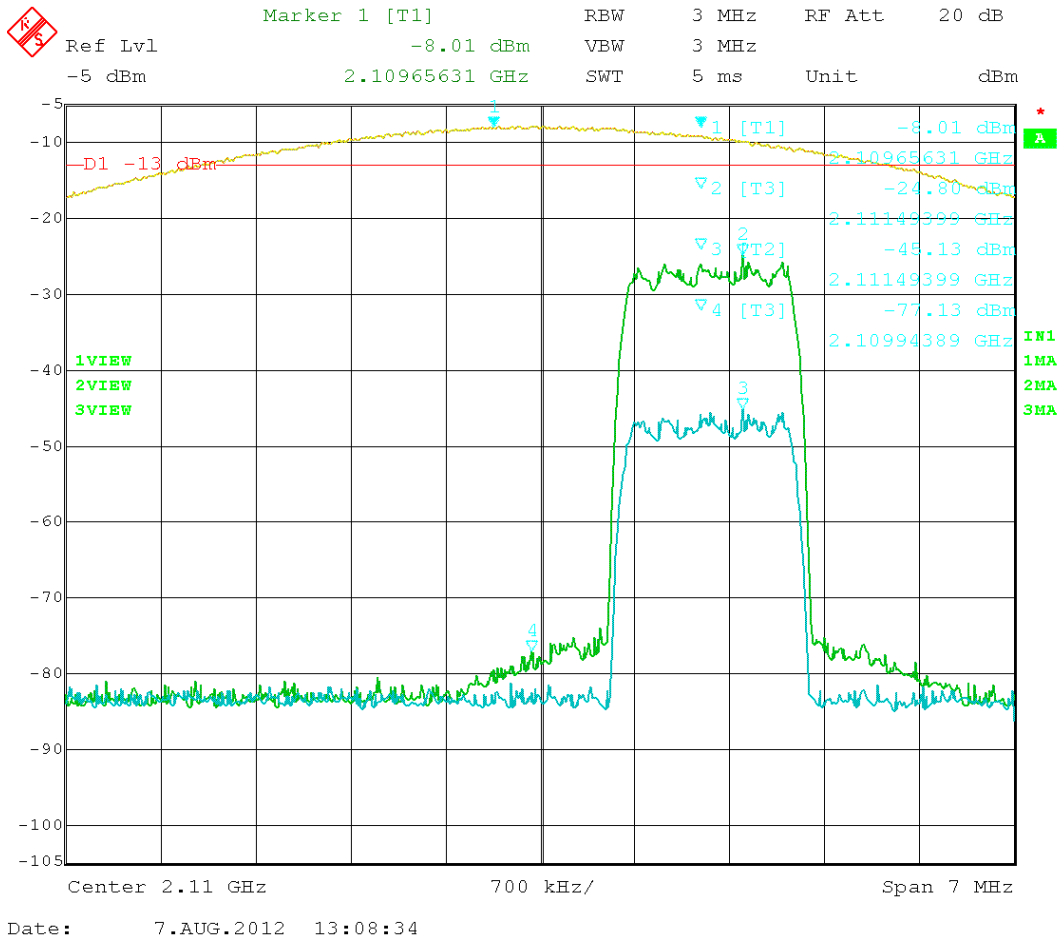

Figure 27: CDMA – In vs. Out 2111.25MHz

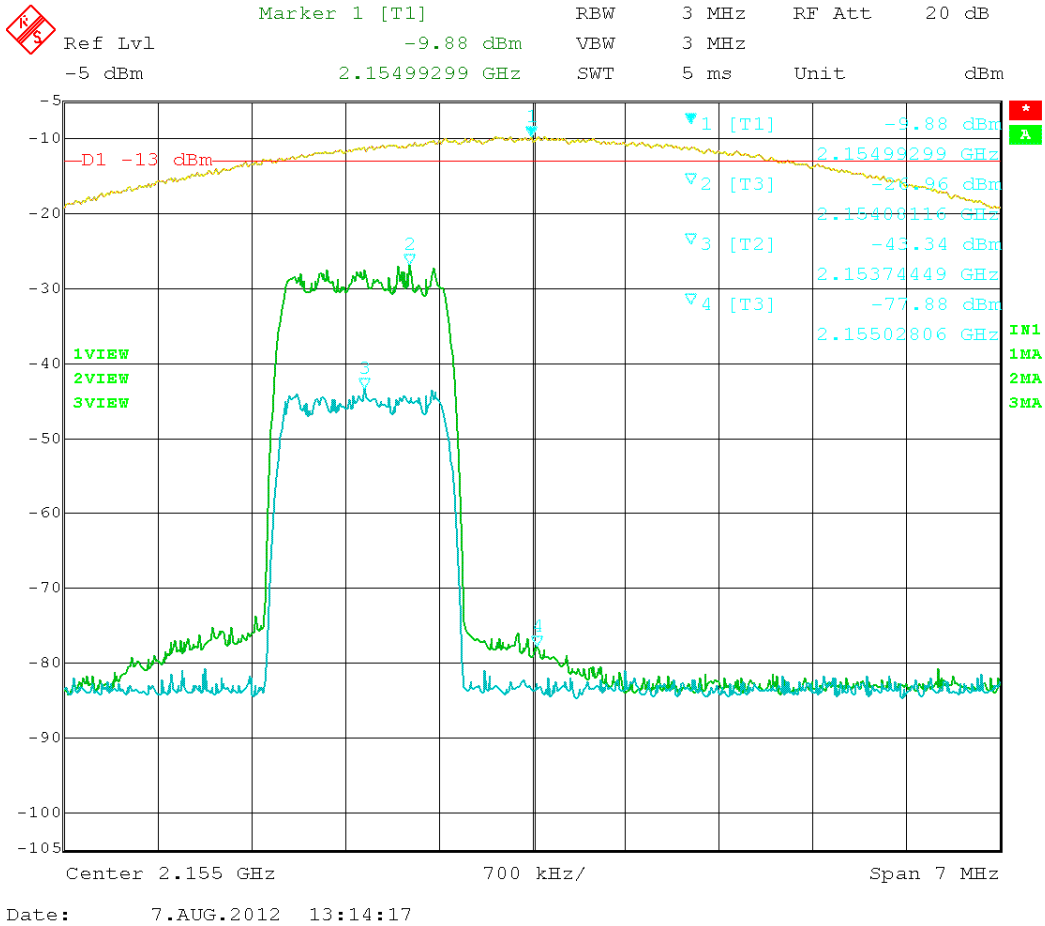
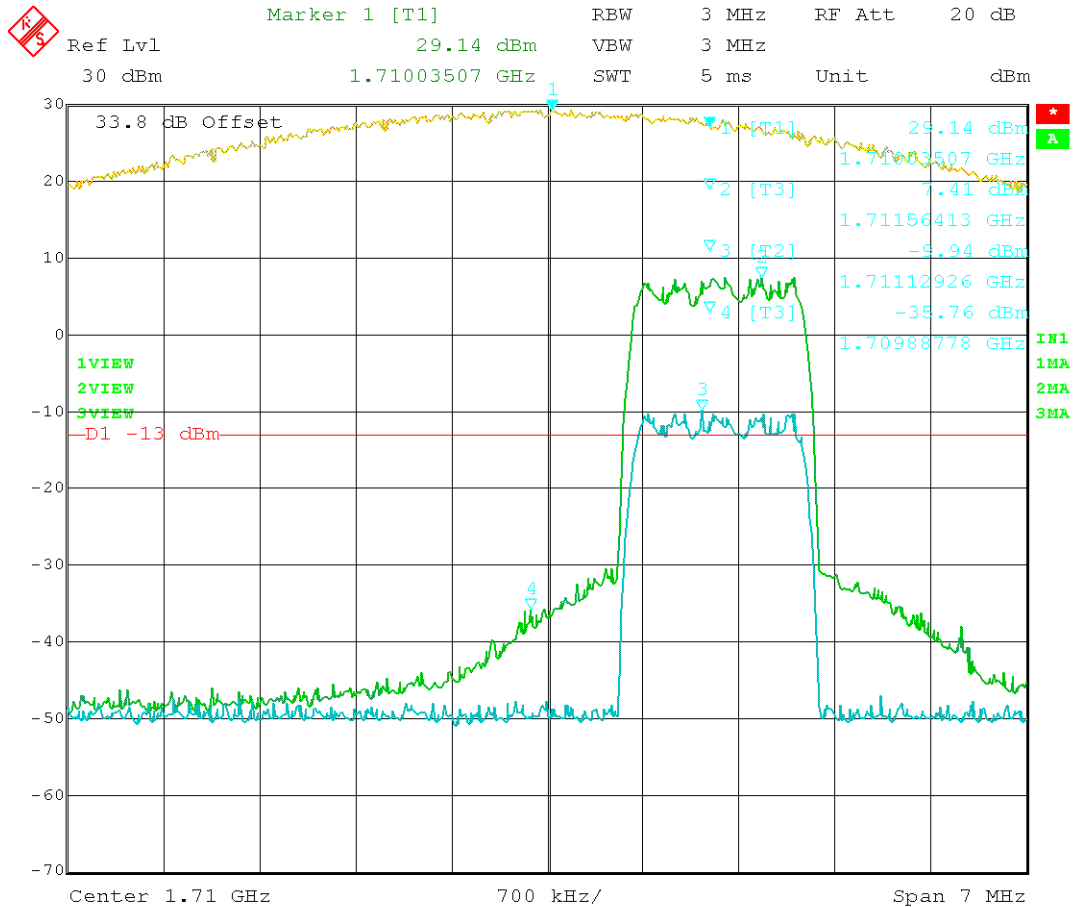

Figure 28: CDMA – In vs. Out 2153.75MHz

Test Data Table 26 – EVDO 1700 – Uplink/Downlink

Channel (MHz)	Bandedge Frequency (MHz)	Amplitude bandedge (dBm)	Limit (dBm)	Margin (dB)
1711.25	1709.89	-35.76	-13	22.76
1753.75	1755.08	-38.73	-13	25.73
2111.25	2109.97	-79.31	-13	66.31
2153.75	2155.09	-79.54	-13	66.54



Date: 7.AUG.2012 14:43:50

Figure 29: EVDO – In vs. Out 1711.25MHz

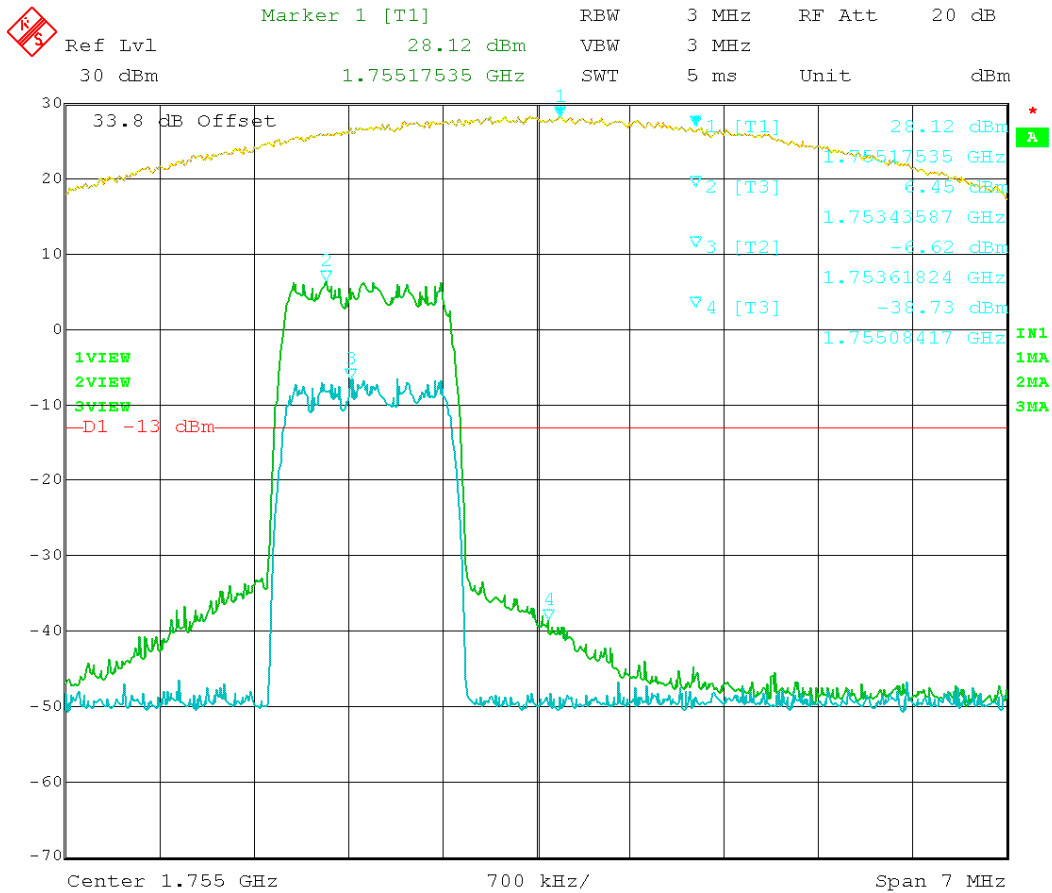

Date: 7.AUG.2012 14:33:54

Figure 30: EVDO – In vs. Out 1753.75MHz

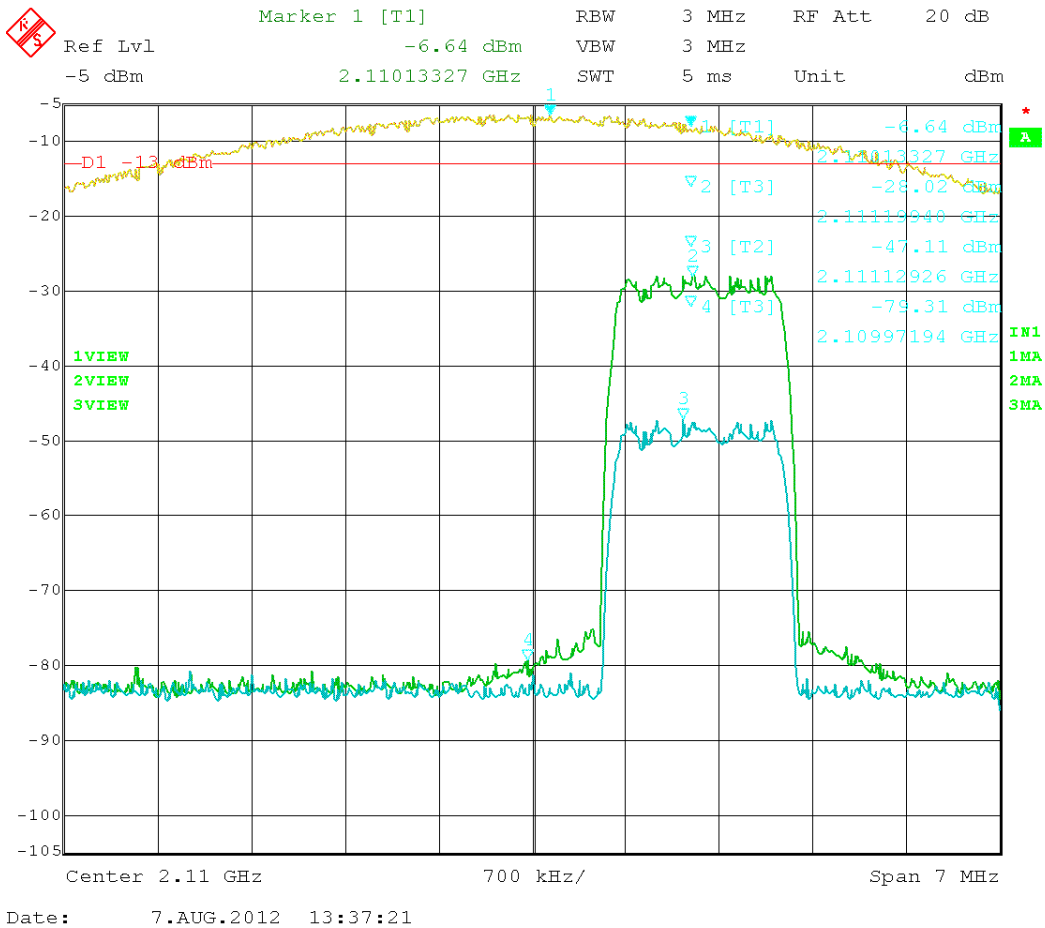

Figure 31: EVDO – In vs. Out 2111.25MHz

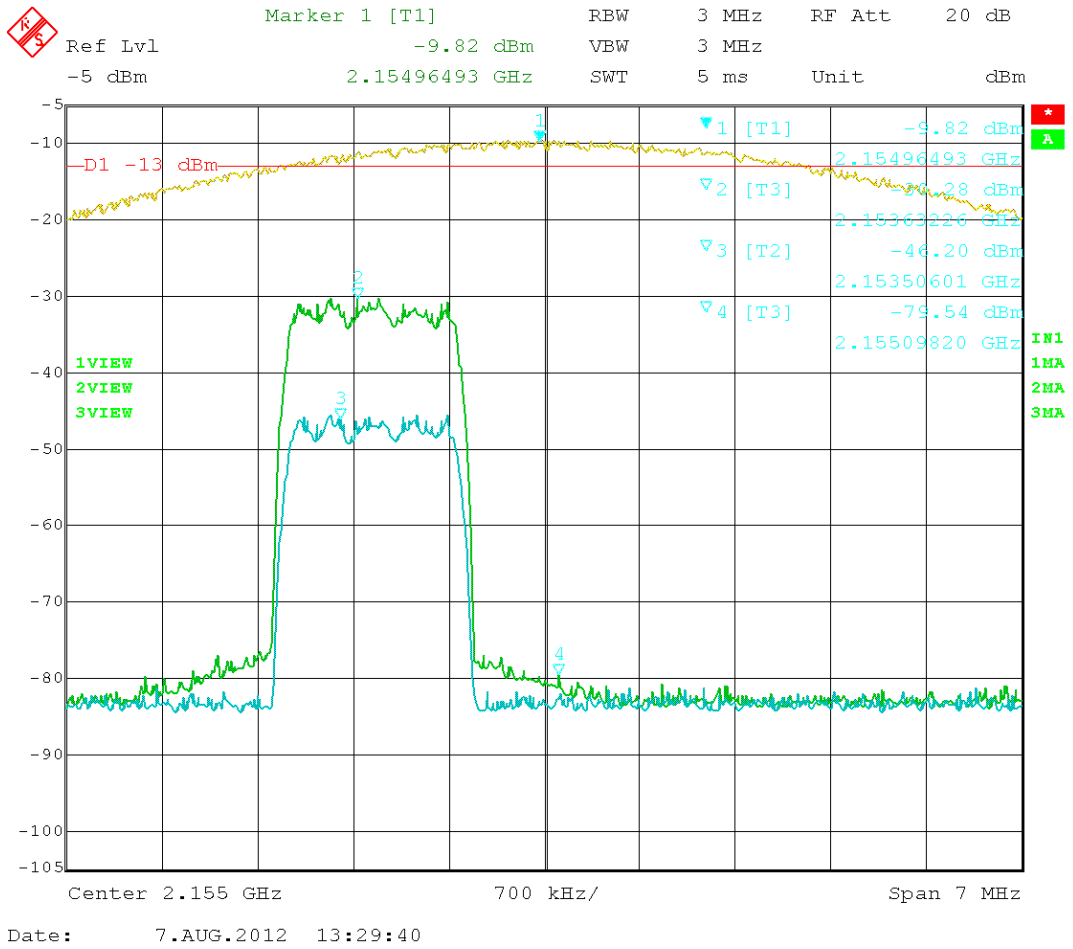

Figure 32: EVDO – In vs. Out 2153.75MHz

Test Data Table 27 – HSPA 1700 – Uplink/Downlink

Channel (MHz)	Bandedge Frequency (MHz)	Amplitude bandedge (dBm)	Limit (dBm)	Margin (dB)
1712.5	1709.12	-30.9	-13	17.9
1752.5	1755.24	-34.02	-13	21.02
2112.5	2109.84	-74.69	-13	61.69
2152.5	2155.60	-80.54	-13	67.54

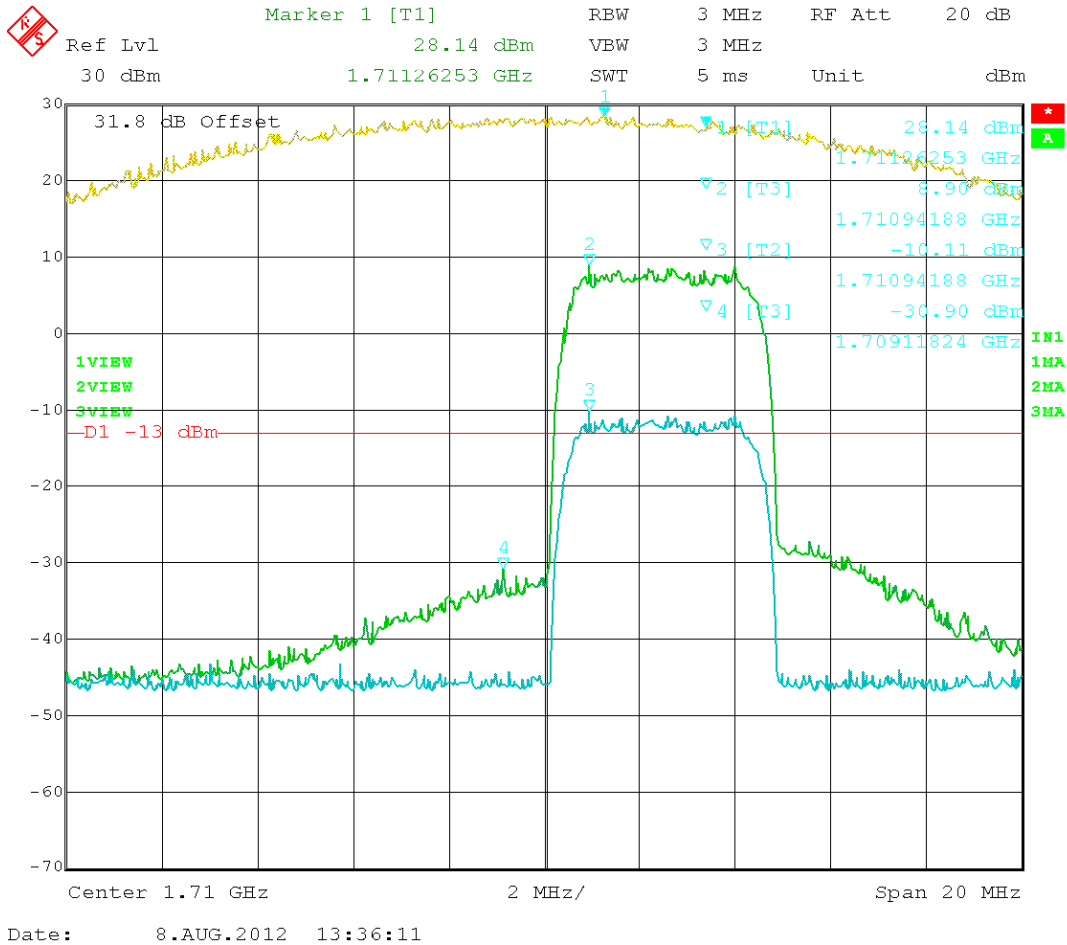

Figure 33: HSPA – In vs. Out 1712.50 MHz

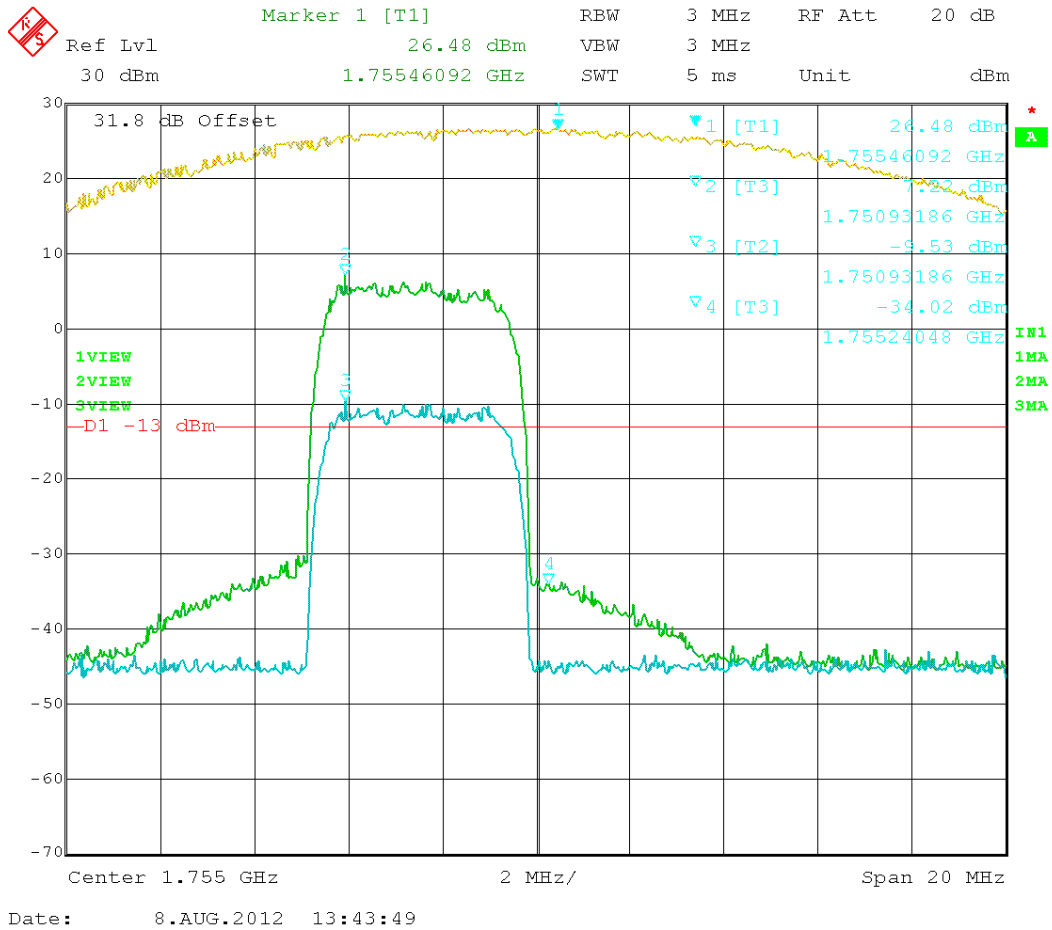

Figure 34: HSPA – In vs. Out 1752.50 MHz

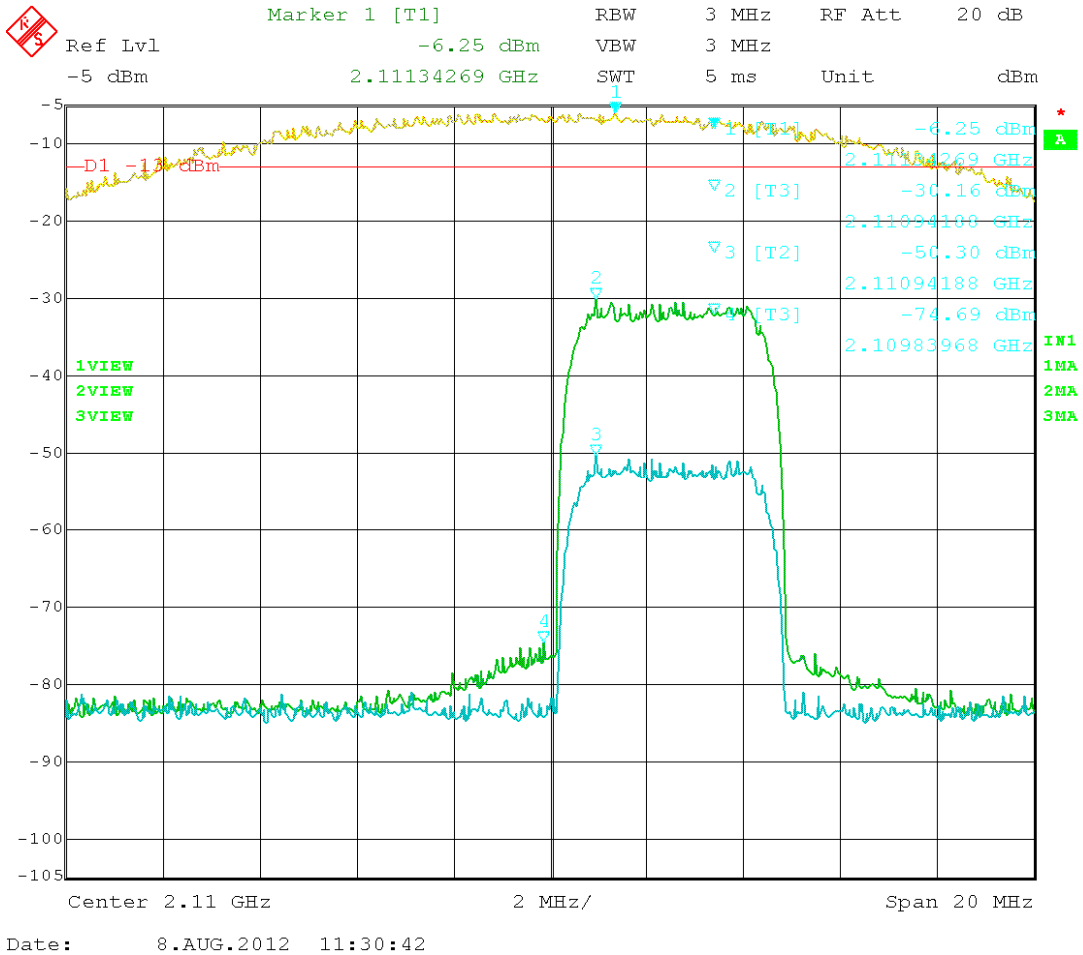

Figure 35: HSPA – In vs. Out 2112.50 MHz

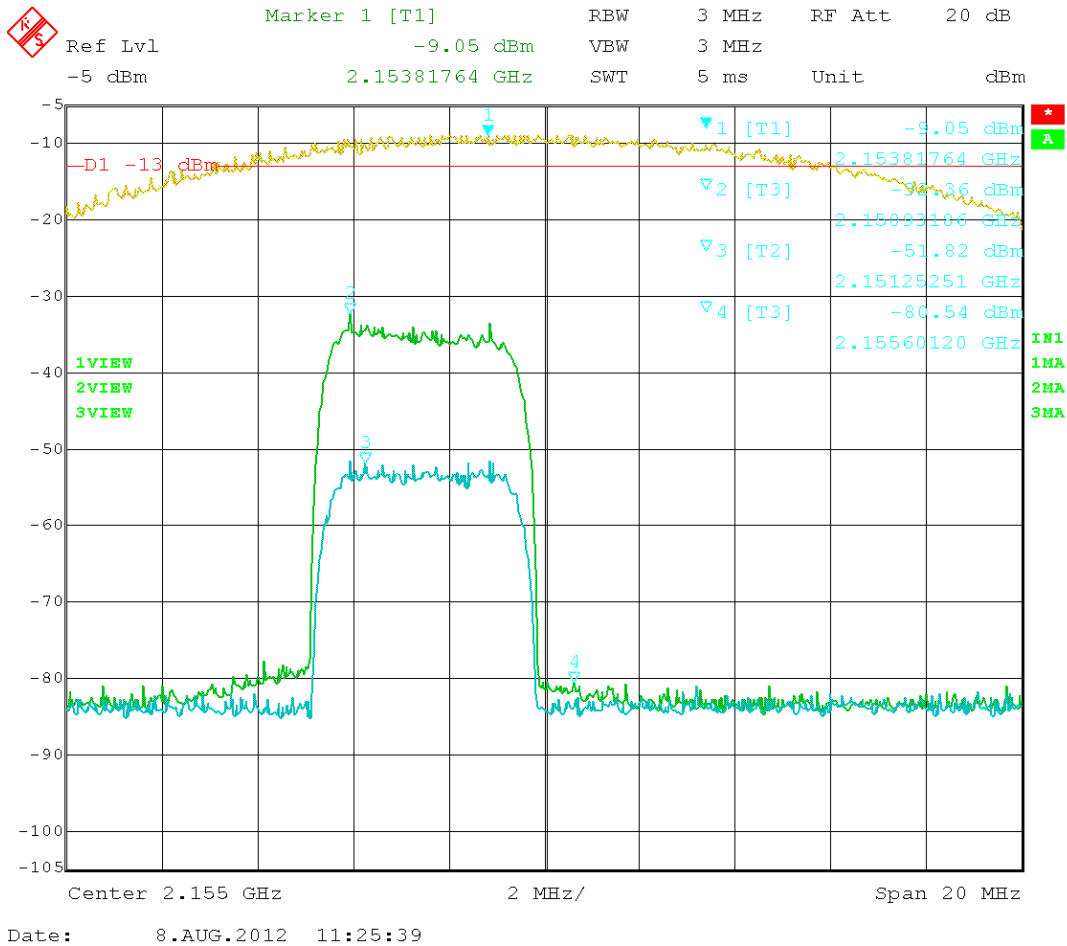

Figure 36: HSPA – In vs. Out 2152.50 MHz

Test Data Table 28 – LTE 1700 – Uplink/Downlink

Channel (MHz)	Band-edge Frequency (MHz)	Amplitude level at the band-edge (dBm)	Limit (dBm)	Margin (dB)
1715.0	1709.76	-31.35	-13	18.35
1750.0	1756.28	-34.49	-13	21.49
2115.0	2109.4	-74.18	-13	61.18
2150.0	2156.44	-75.36	-13	62.36

The Reference level on the following plots was calibrated using a 3MHz RBW=VBW.

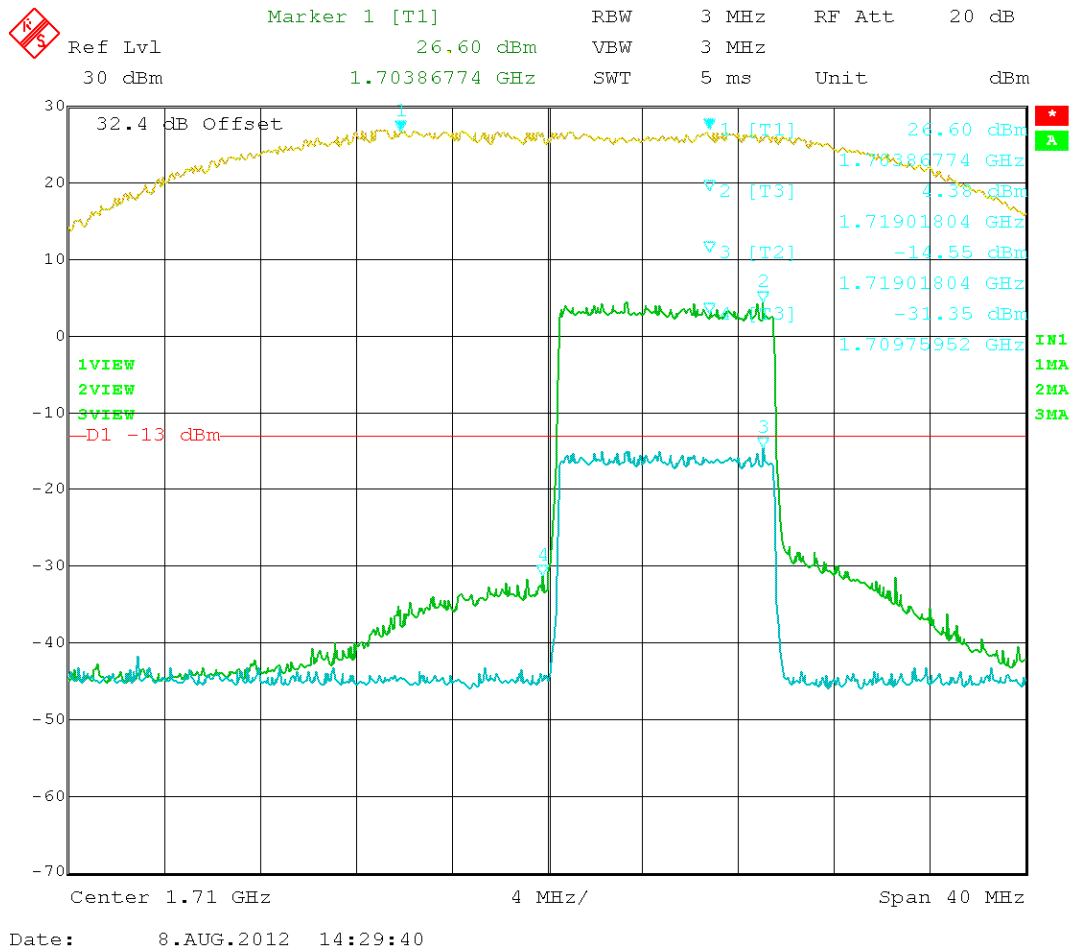

Figure 37: LTE – In vs. Out 1715.00MHz

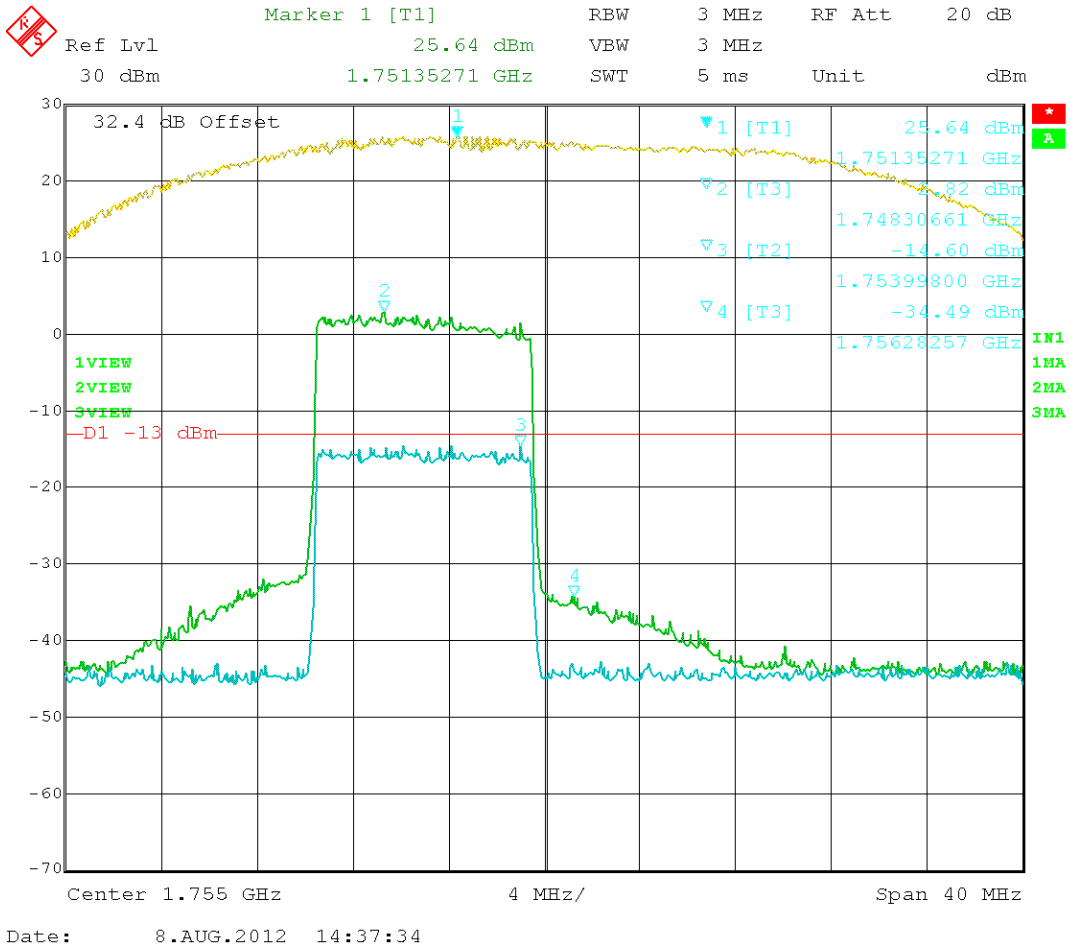

Figure 38: LTE – In vs. Out 1750.00MHz

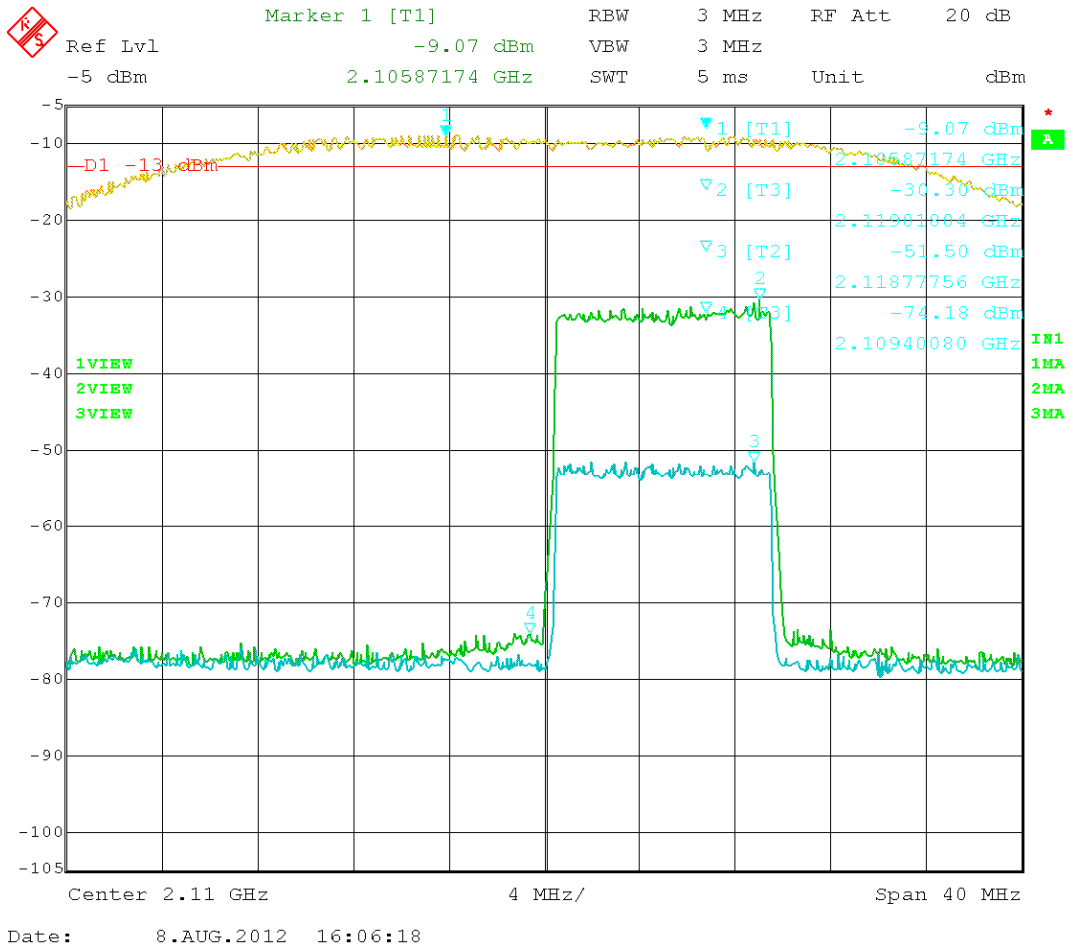

Figure 39: LTE – In vs. Out 2115.00MHz

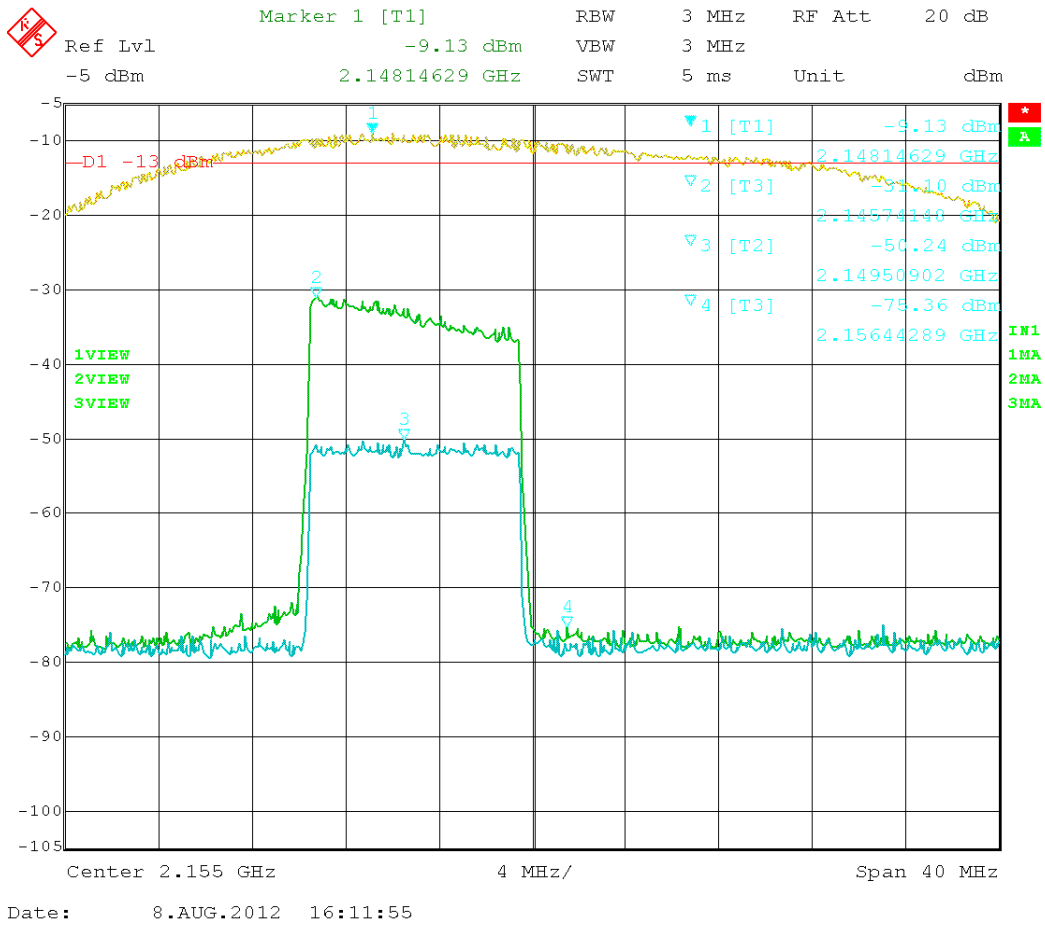

Figure 40: LTE – In vs. Out 2150.00MHz

Test Data Table 29 –GSM 1700 – Uplink/Downlink

Channel (MHz)	Band-edge Frequency (MHz)	Amplitude level at the band-edge (dBm)	Limit (dBm)	Margin (dB)
1710.2	1709.98	-19.32	-13	6.32
1754.8	1755.02	-23.44	-13	10.44
2110.2	2109.98	-52.7	-13	39.7
2154.8	2155.02	-54.38	-13	41.38

The Reference level on the following plots was calibrated using a 3MHz RBW=VBW.

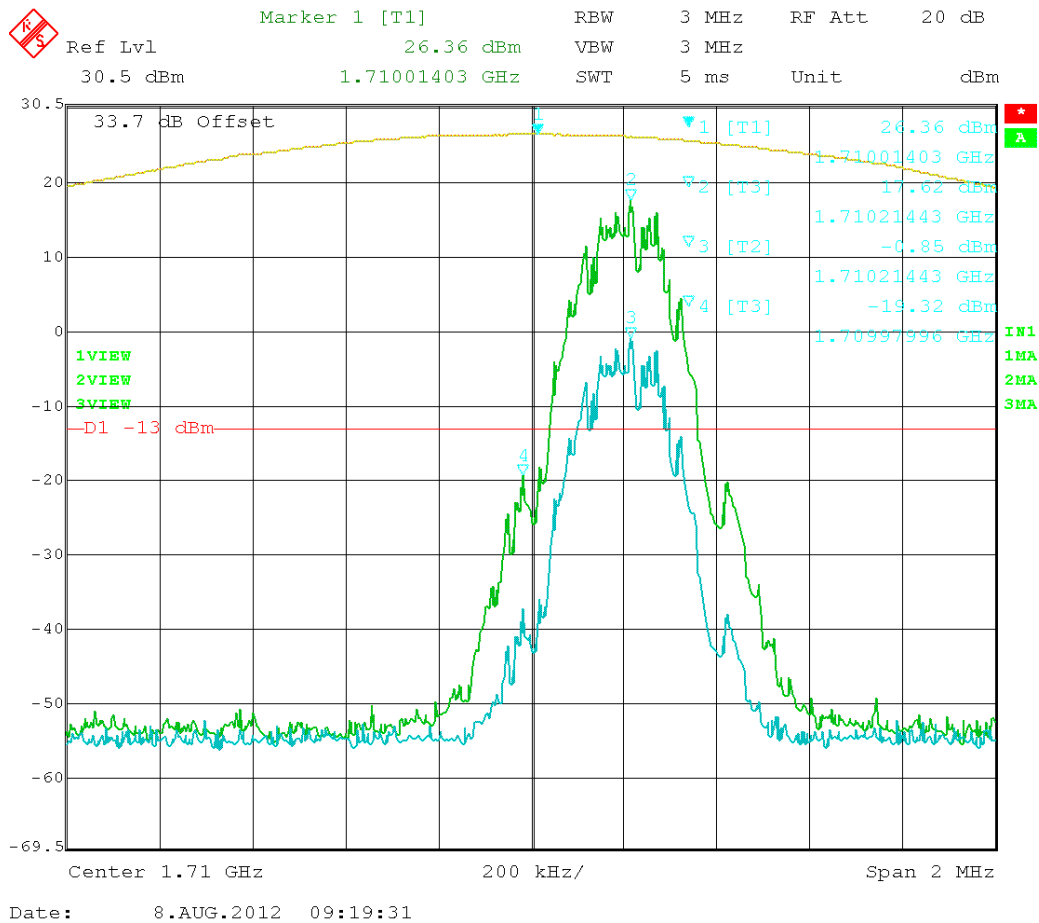

Figure 41: GSM – In vs. Out 1710.20MHz

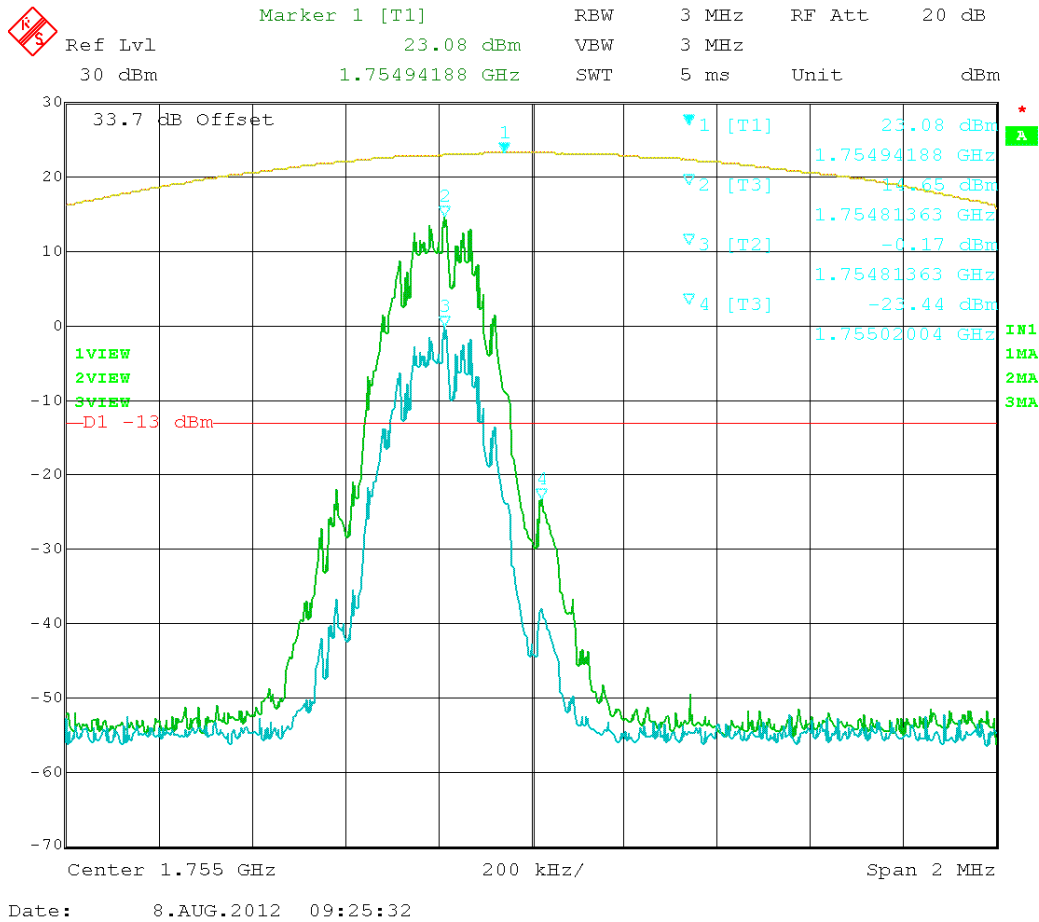

Figure 42: GSM – In vs. Out 1754.80MHz

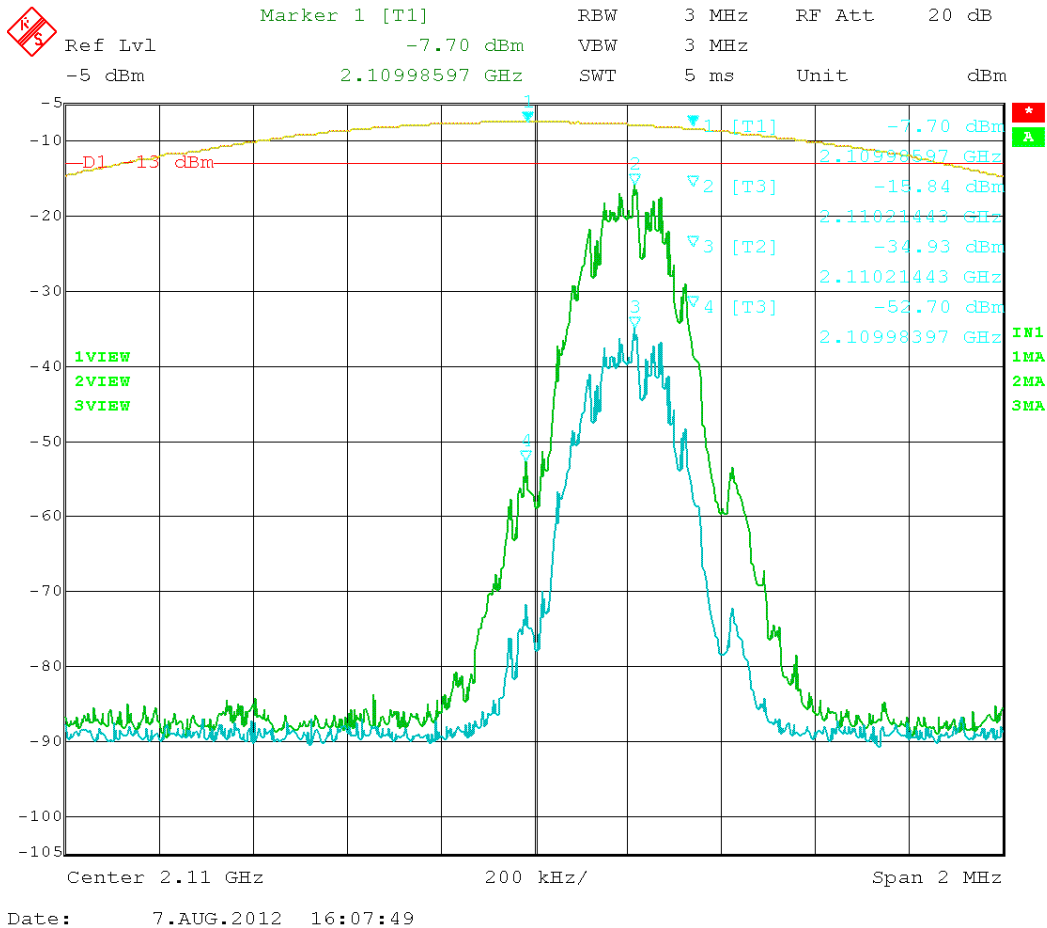

Figure 43: GSM – In vs. Out 2110.20MHz

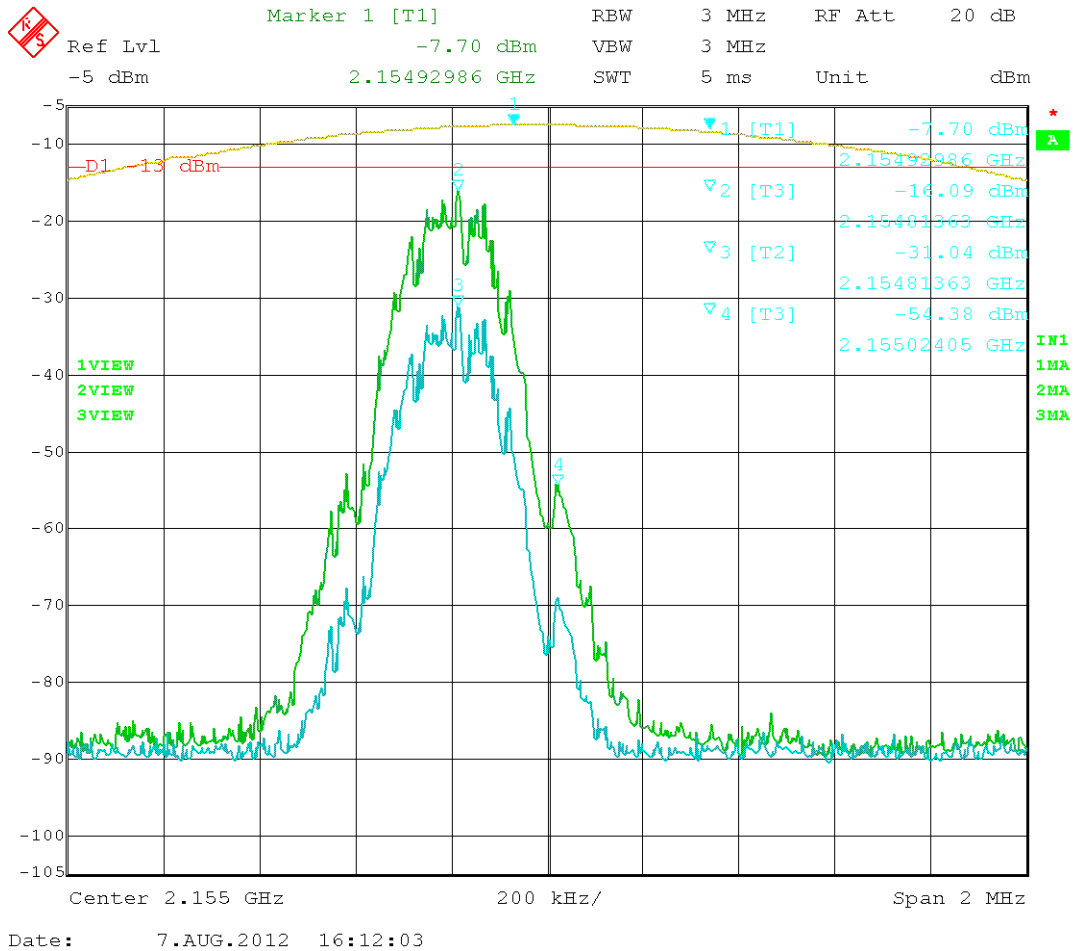

Figure 44: GSM – In vs. Out 2154.80MHz

Test Data Table 30 – EDGE 1700 – Uplink/Downlink

Channel (MHz)	Band-edge Frequency (MHz)	Amplitude level at the band-edge (dBm)	Limit (dBm)	Margin (dB)
1710.2	1709.98	-22.52	-13	9.52
1754.8	1755.02	-24.55	-13	11.55
2110.2	2109.98	-56.03	-13	43.03
2154.8	2155.02	-59.02	-13	46.02

The Reference level on the following plots was calibrated using a 3MHz RBW=VBW.

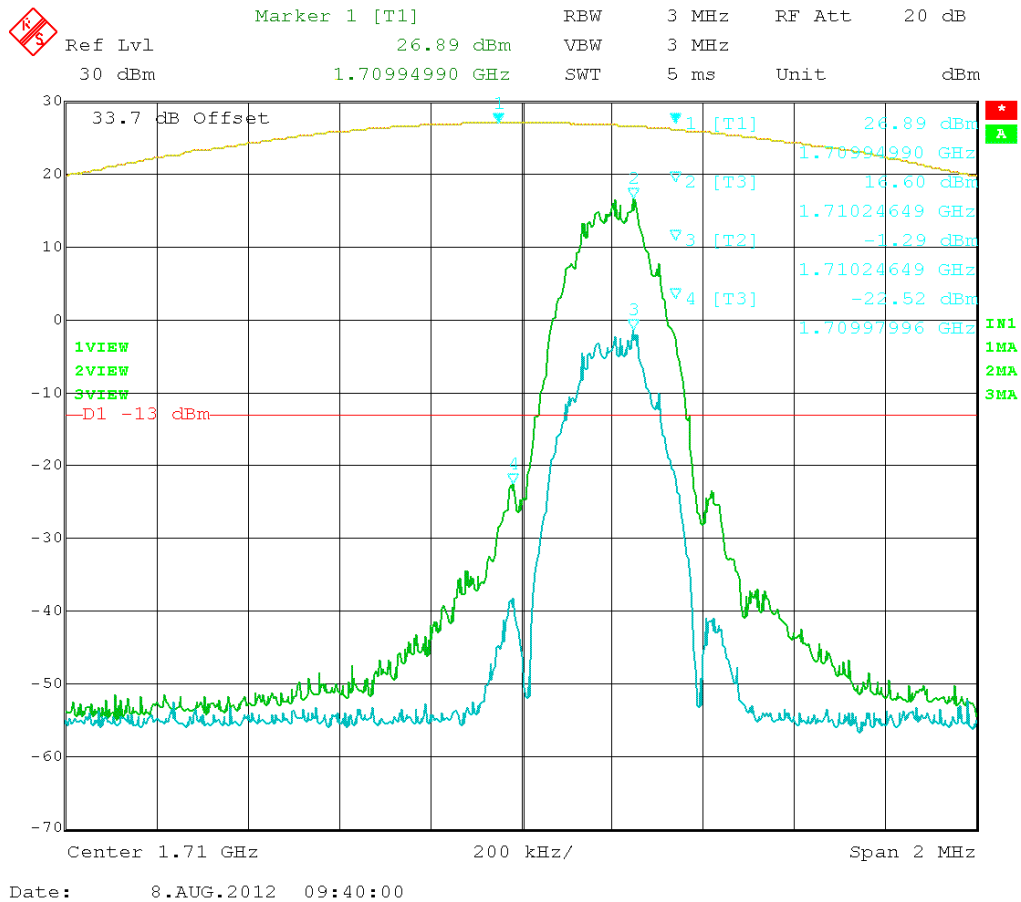

Figure 45: EDGE – In vs. Out 1710.20MHz

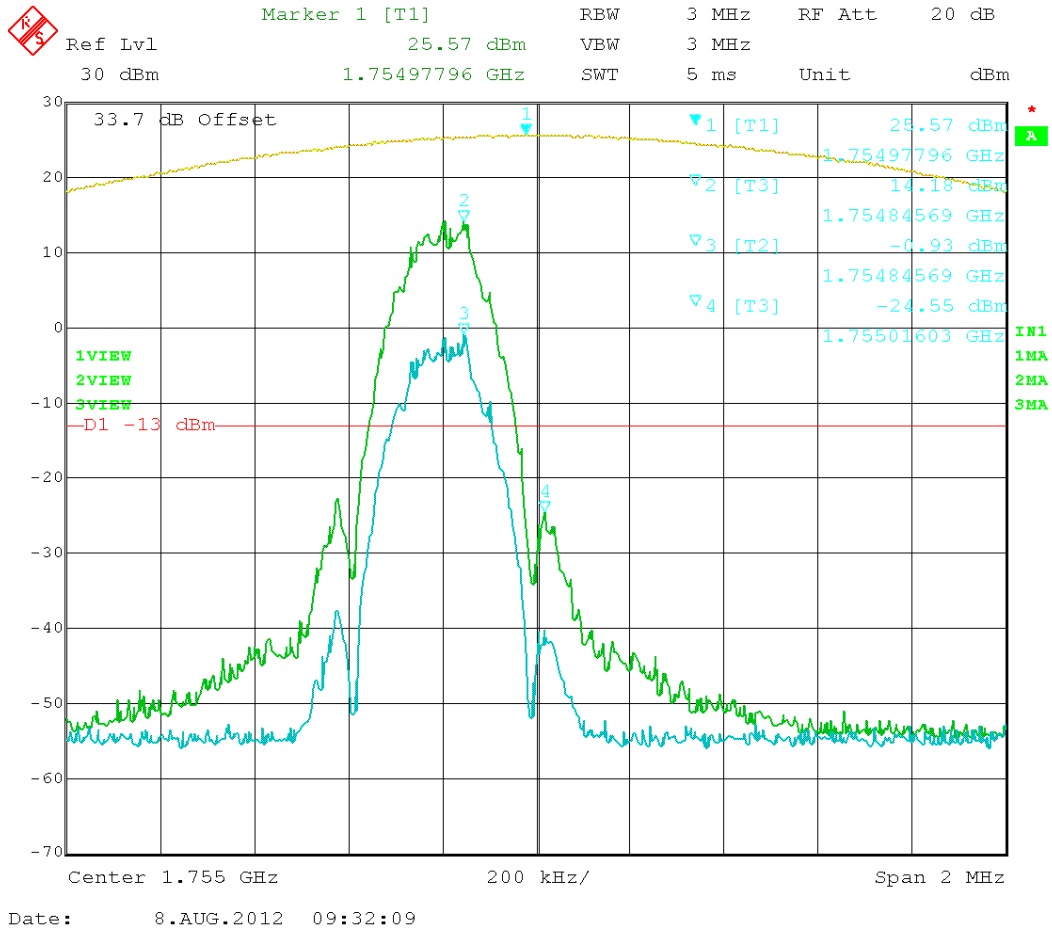

Figure 46: EDGE – In vs. Out 1.755 GHz

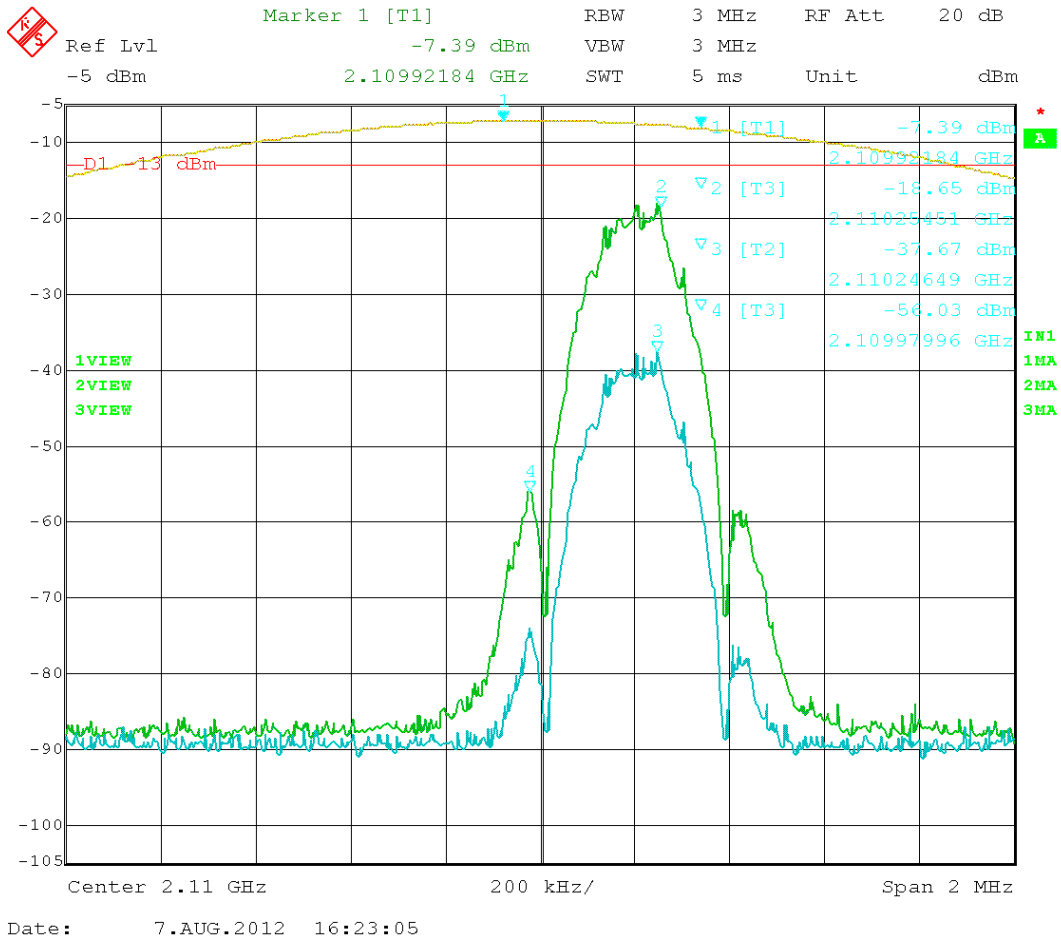

Figure 47: EDGE – In vs. Out 2110.20MHz

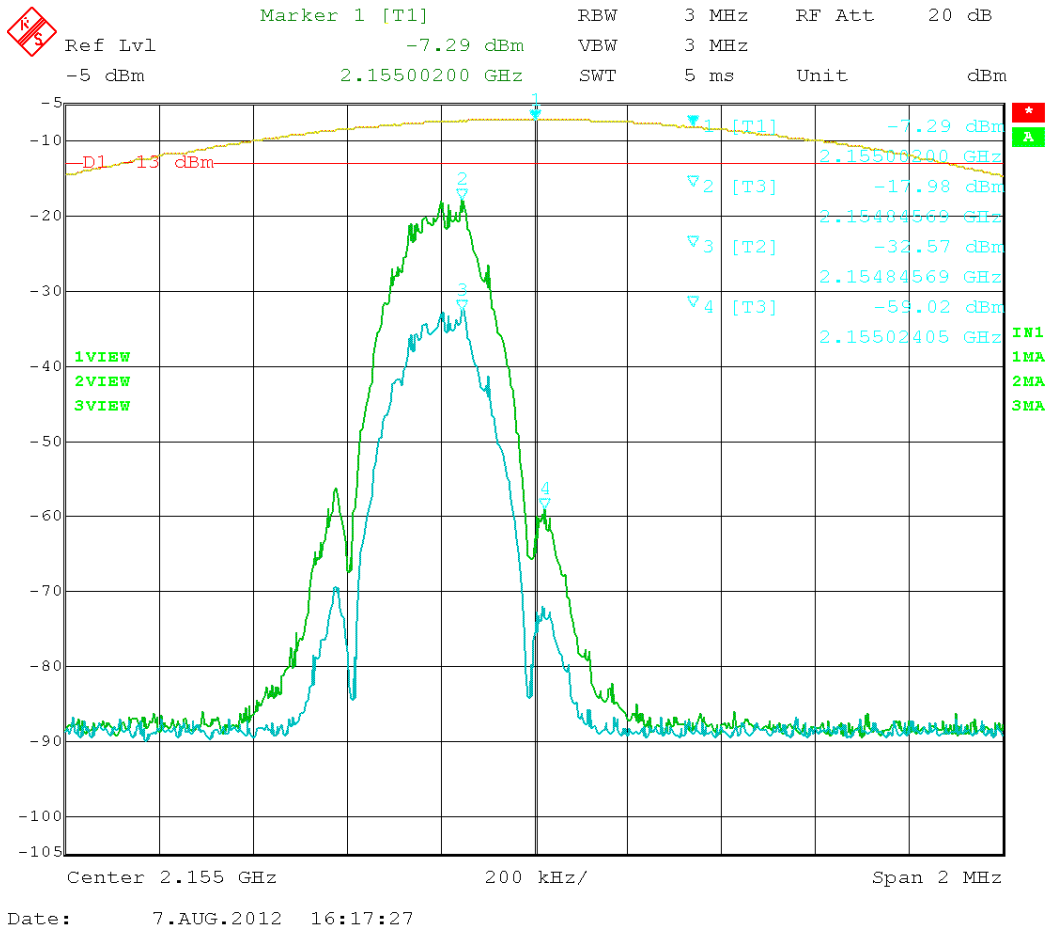

Figure 48: EDGE – In vs. Out 2154.80MHz

Compensating for RBW (1%) using $10 \log(12.5/3) = 6.2$ dB we get the following amplitudes at the bandedge:

Test Data Table 31 – CDMA 800 – Uplink/Downlink

Channel (MHz)	Bandedge Frequency (MHz)	Amplitude level at the band-edge (dBm)	Limit (dBm)	Margin (dB)
825.25	823.87	-34.94	-13	21.94
847.75	849.06	-32.16	-13	19.16
870.25	868.92	-74.9	-13	61.9
892.75	894.11	-77.5	-13	64.5

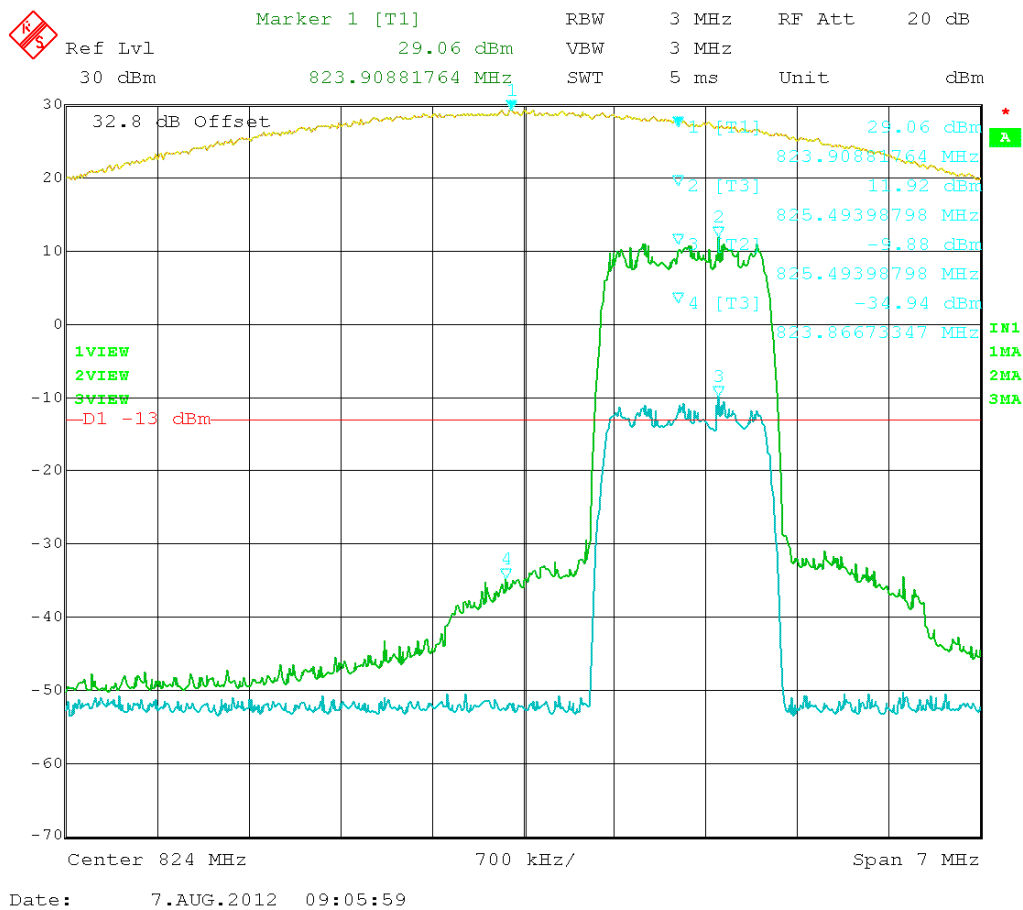
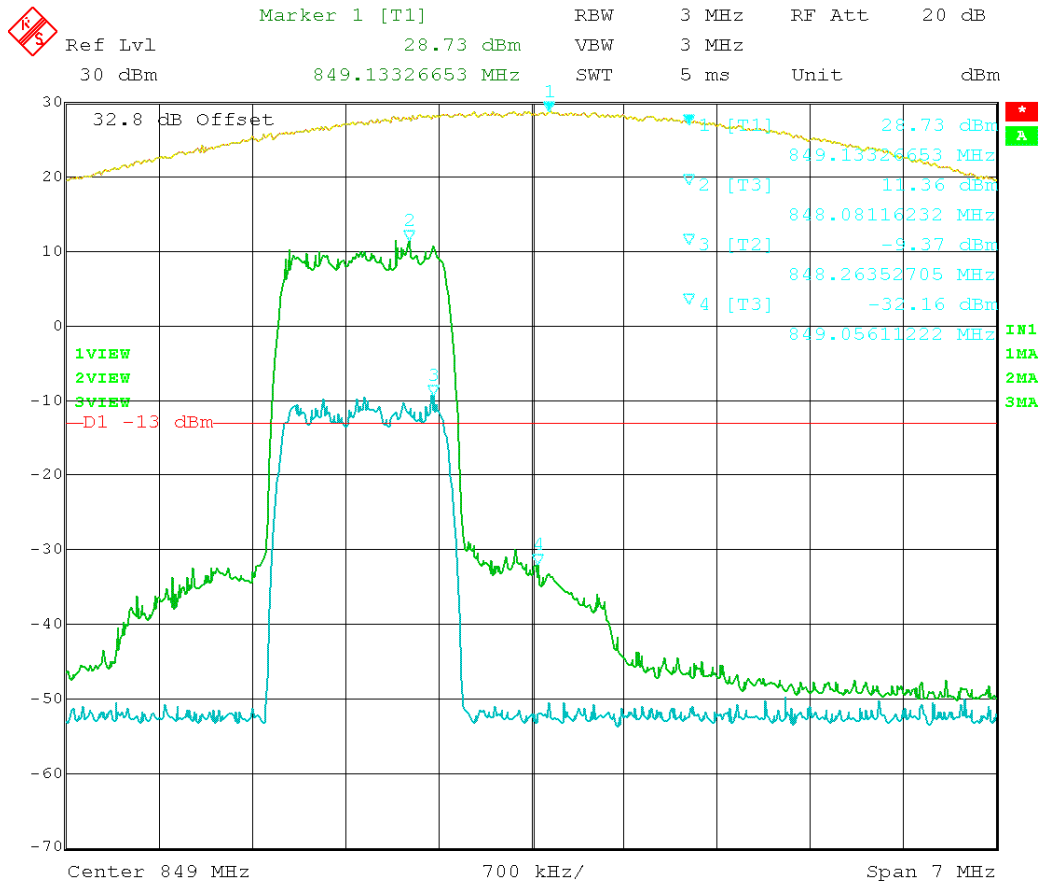

Figure 49: CDMA – In vs. Out 825.25MHz



Date: 7.AUG.2012 09:12:31

Figure 50: CDMA – In vs. Out 847.75 MHz

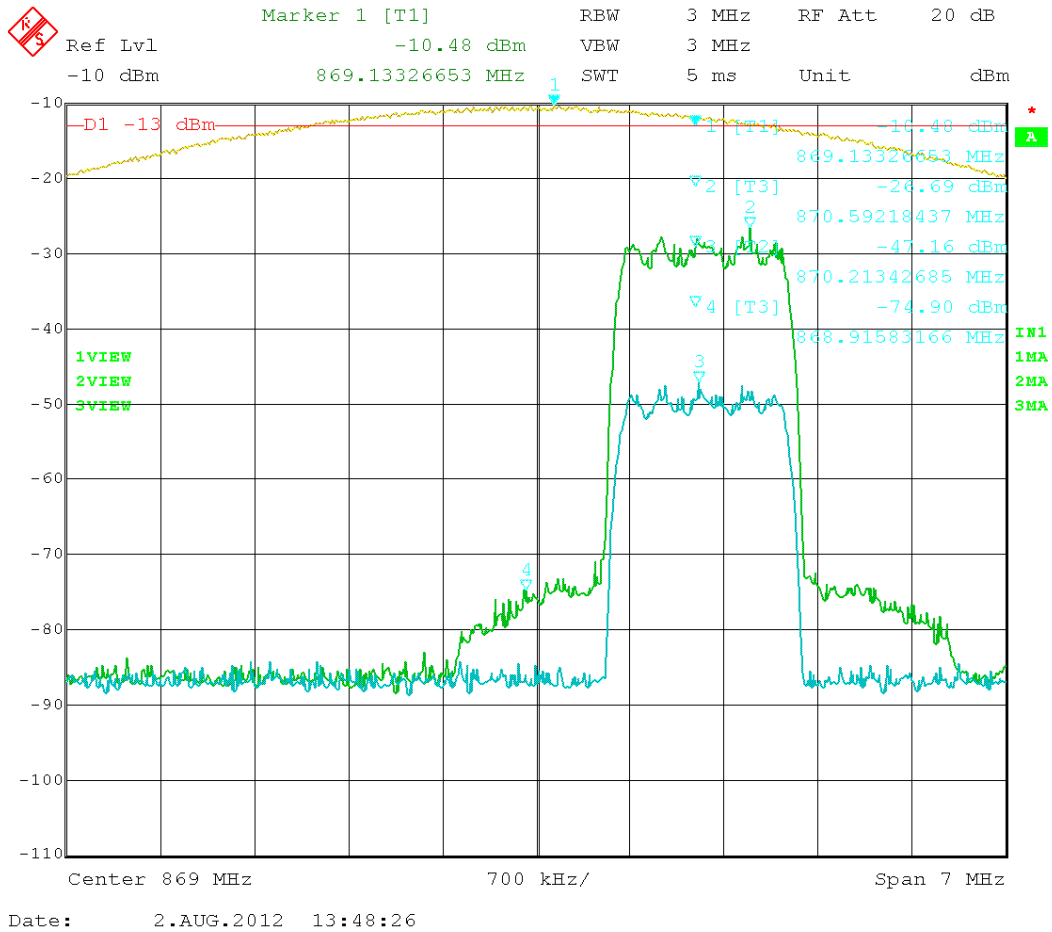

Figure 51: CDMA – In vs. Out 870.25 MHz

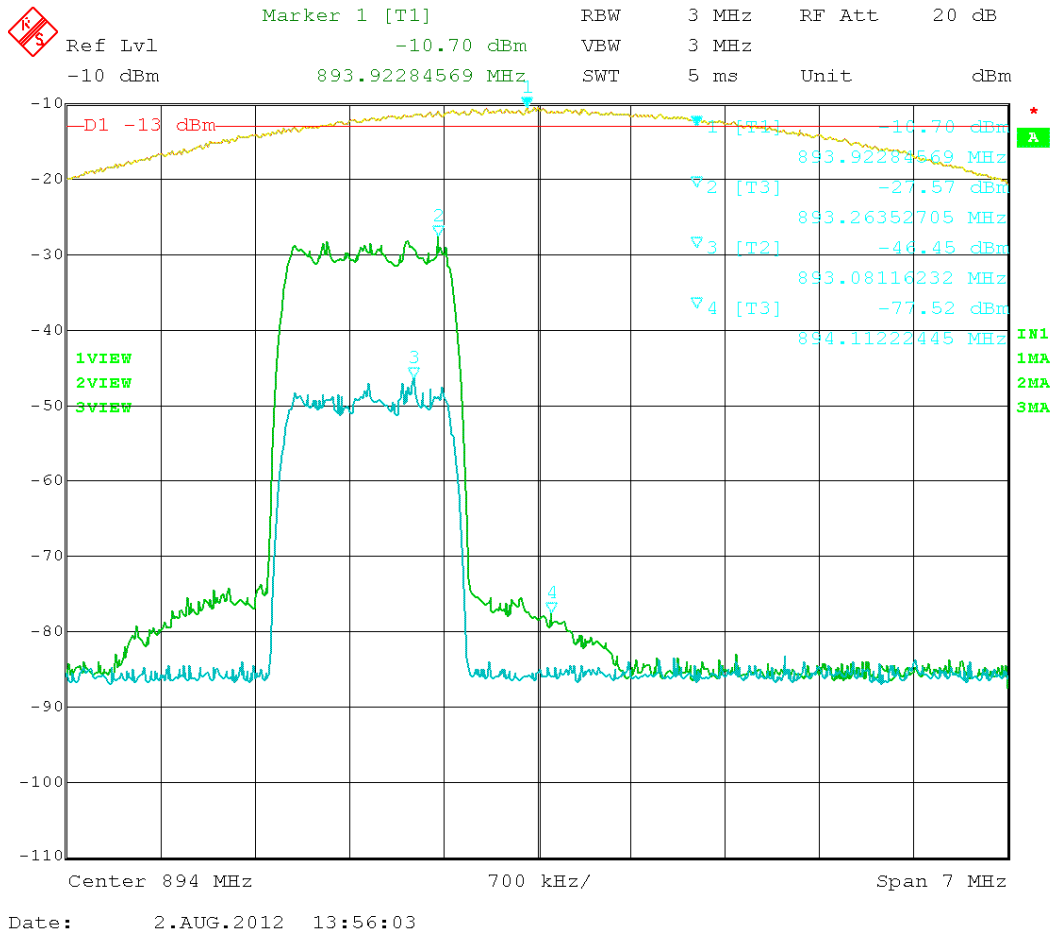

Figure 52: CDMA – In vs. Out 892.75 MHz

Test Data Table 32 – EVDO 800 – Uplink/Downlink

Channel (MHz)	Bandedge Frequency (MHz)	Amplitude level at the band-edge (dBm)	Limit (dBm)	Margin (dB)
825.25	823.96	-32.11	-13	19.11
847.75	849.06	-34.12	-13	21.12
870.25	868.95	-74.47	-13	61.47
892.75	894.06	-74.76	-13	61.76

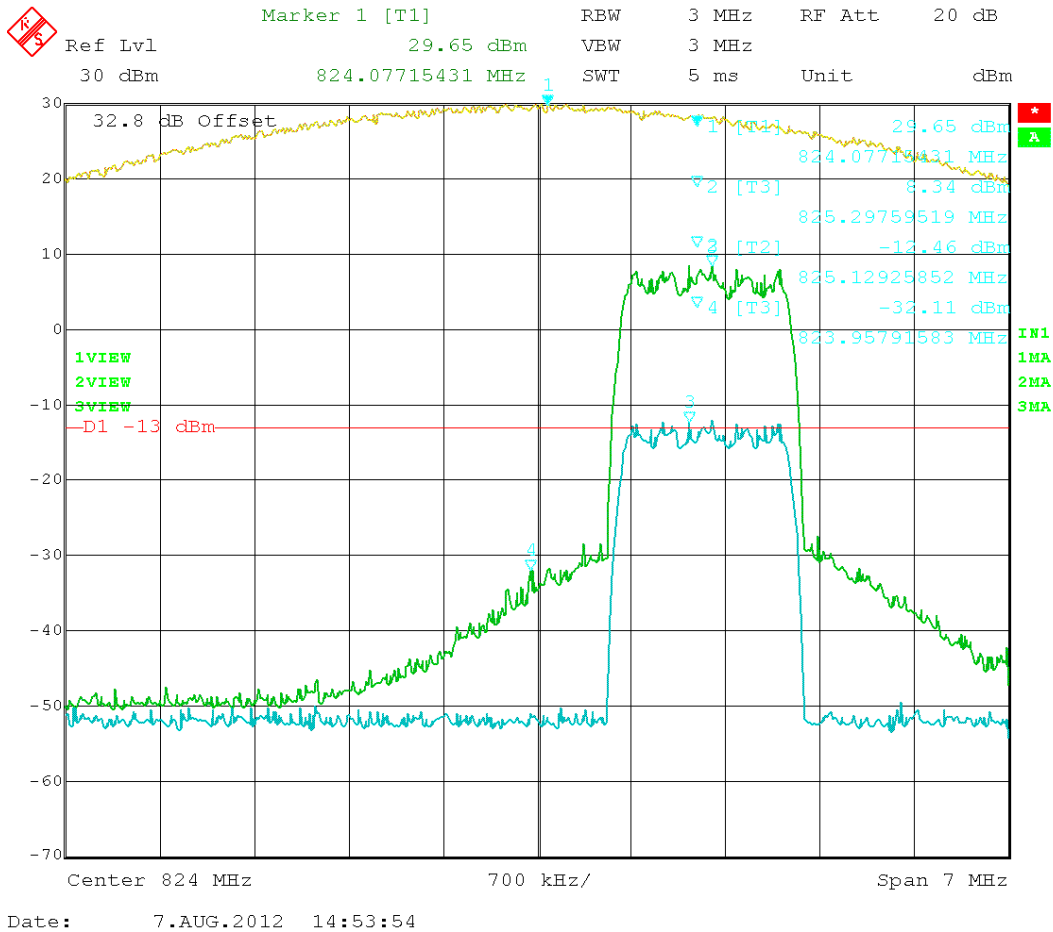

Figure 53: EVDO – In vs. Out 825.25 MHz

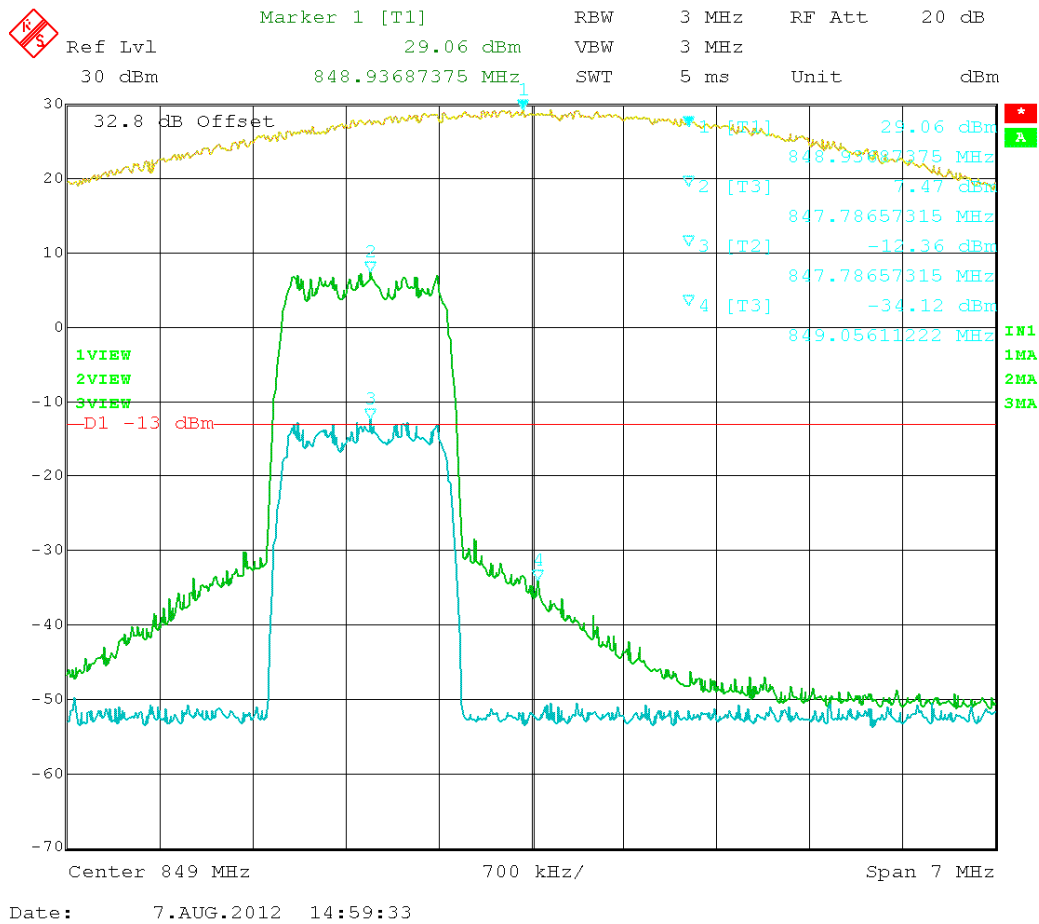

Figure 54: EVDO – In vs. Out 847.75 MHz

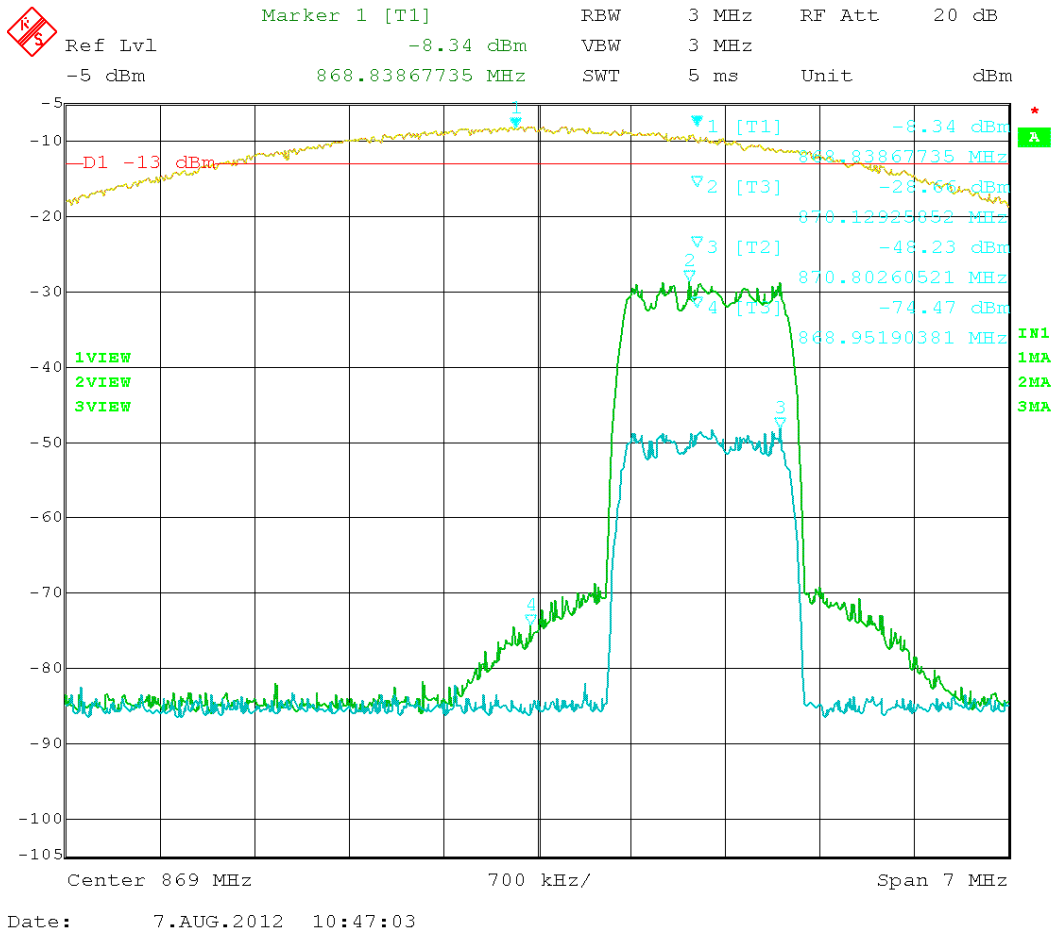
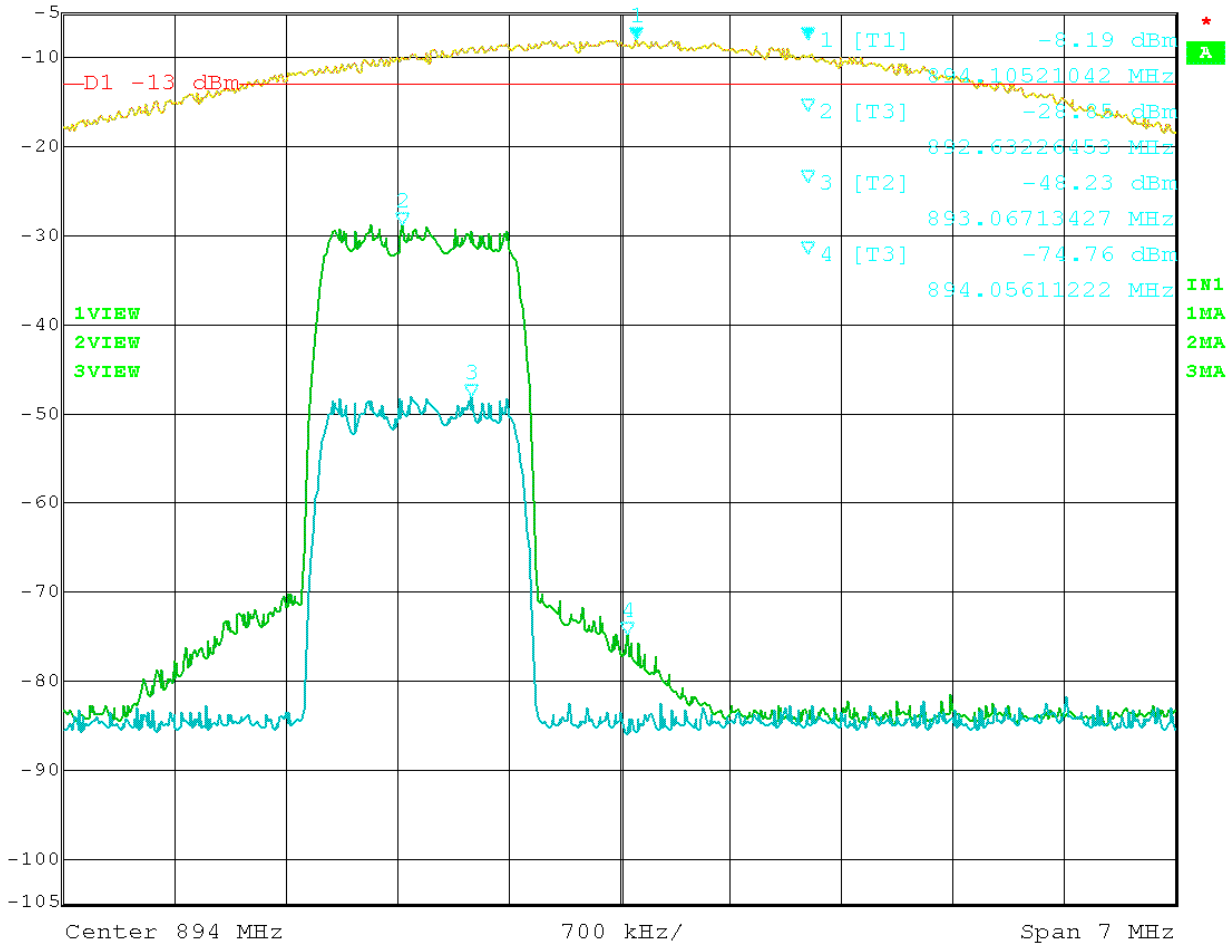

Figure 55: EVDO – In vs. Out 870.25 MHz



Marker 1 [T1] RBW 3 MHz RF Att 20 dB
 Ref Lvl -5 dBm -8.19 dBm VBW 3 MHz
 -5 dBm 894.10521042 MHz SWT 5 ms Unit dBm



Date: 7.AUG.2012 10:52:28

Figure 56: EVDO – In vs. Out 892.75 MHz

Test Data Table 33 – HSPA 800 – Uplink/Downlink

Channel (MHz)	Bandedge Frequency (MHz)	Amplitude level at the band-edge (dBm)	Limit (dBm)	Margin (dB)
826.5	823.76	-29.54	-13	16.54
846.5	849.81	-27.77	-13	14.77
871.5	868.36	-69.48	-13	56.48
891.5	894.48	-70.8	-13	57.8

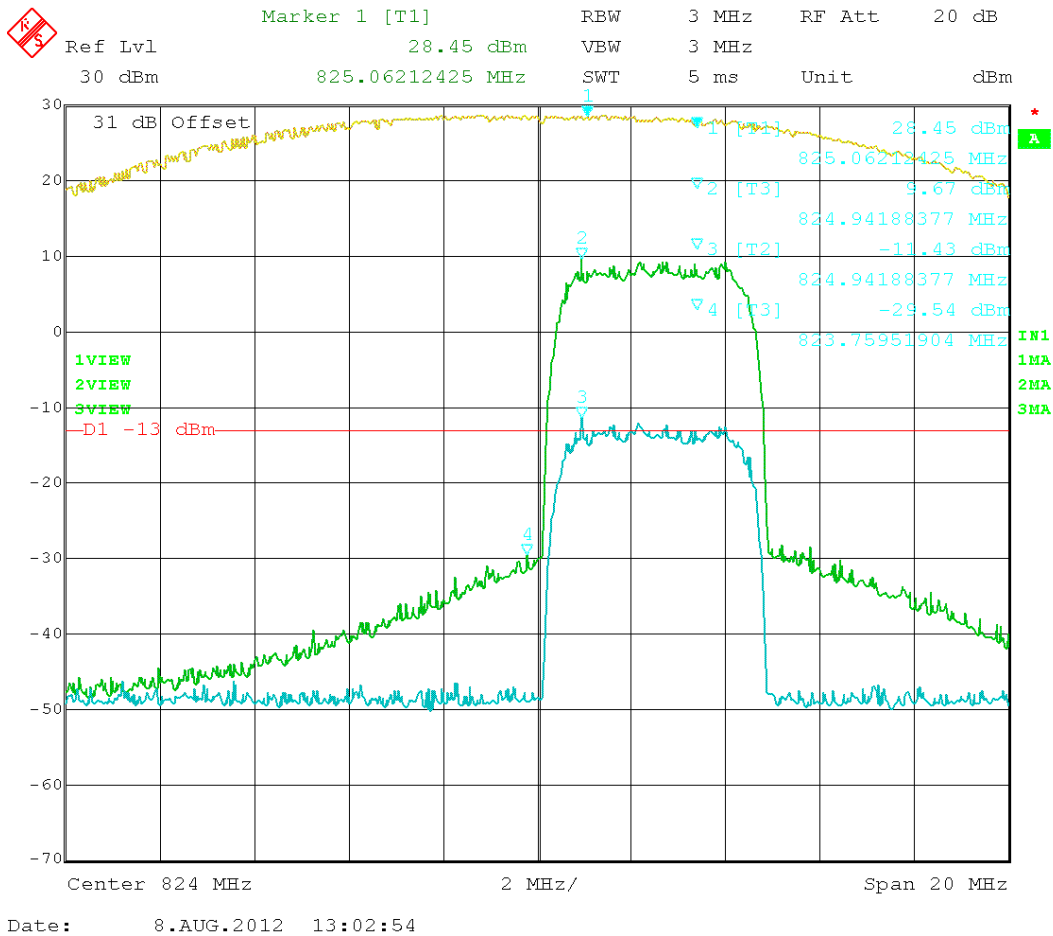

Figure 57: HSPA – In vs. Out 826.50 MHz

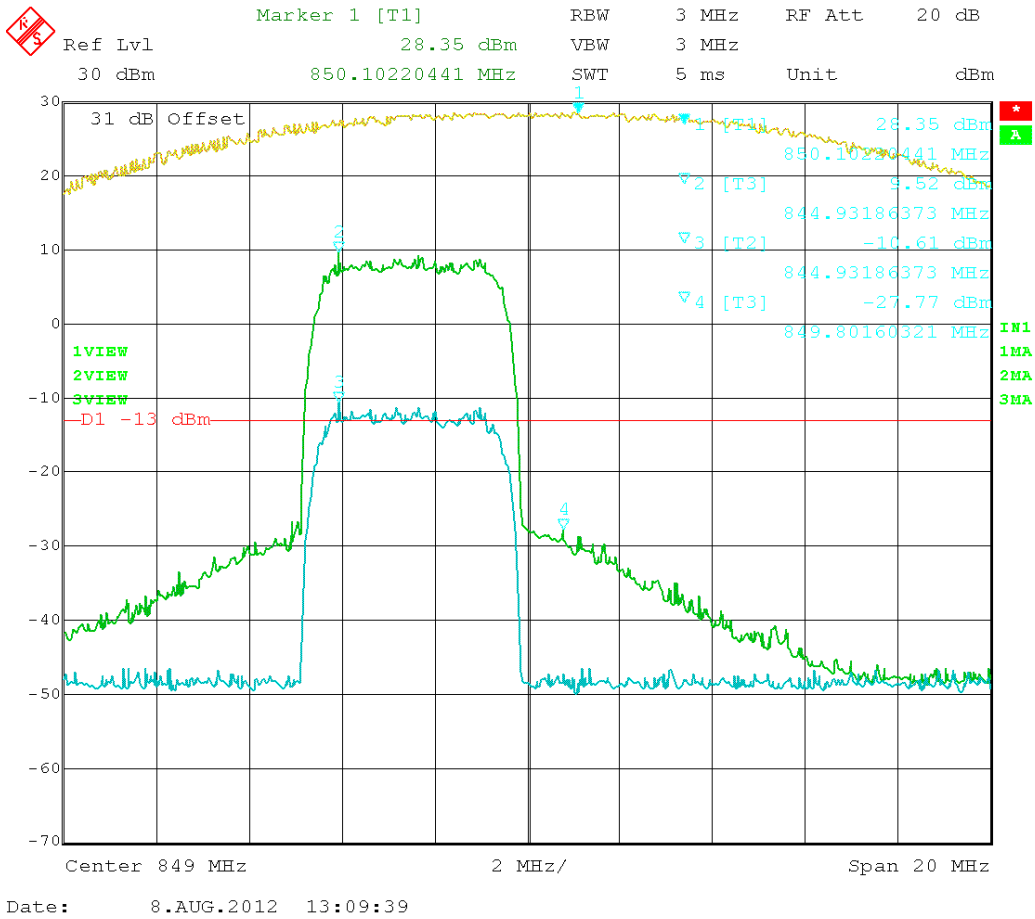

Figure 58: HSPA – In vs. Out 846.50 MHz

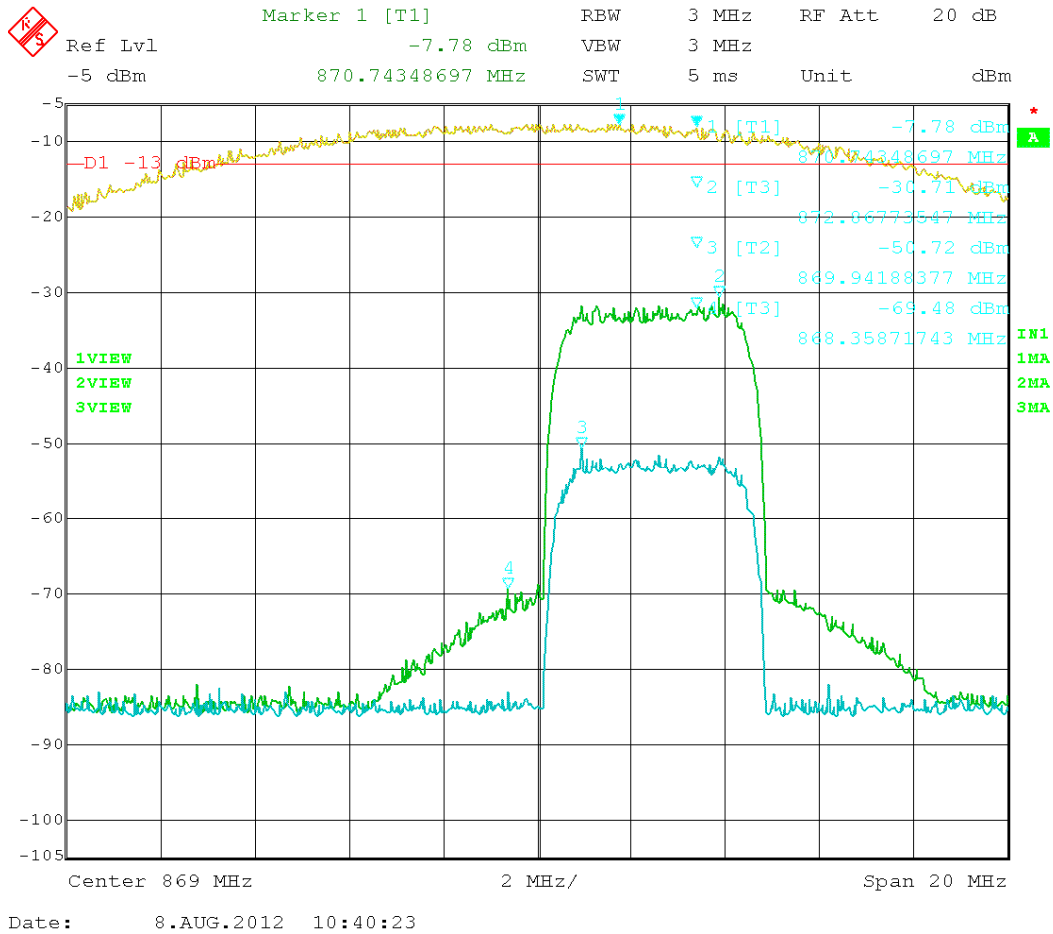

Figure 59: HSPA – In vs. Out 871.50 MHz

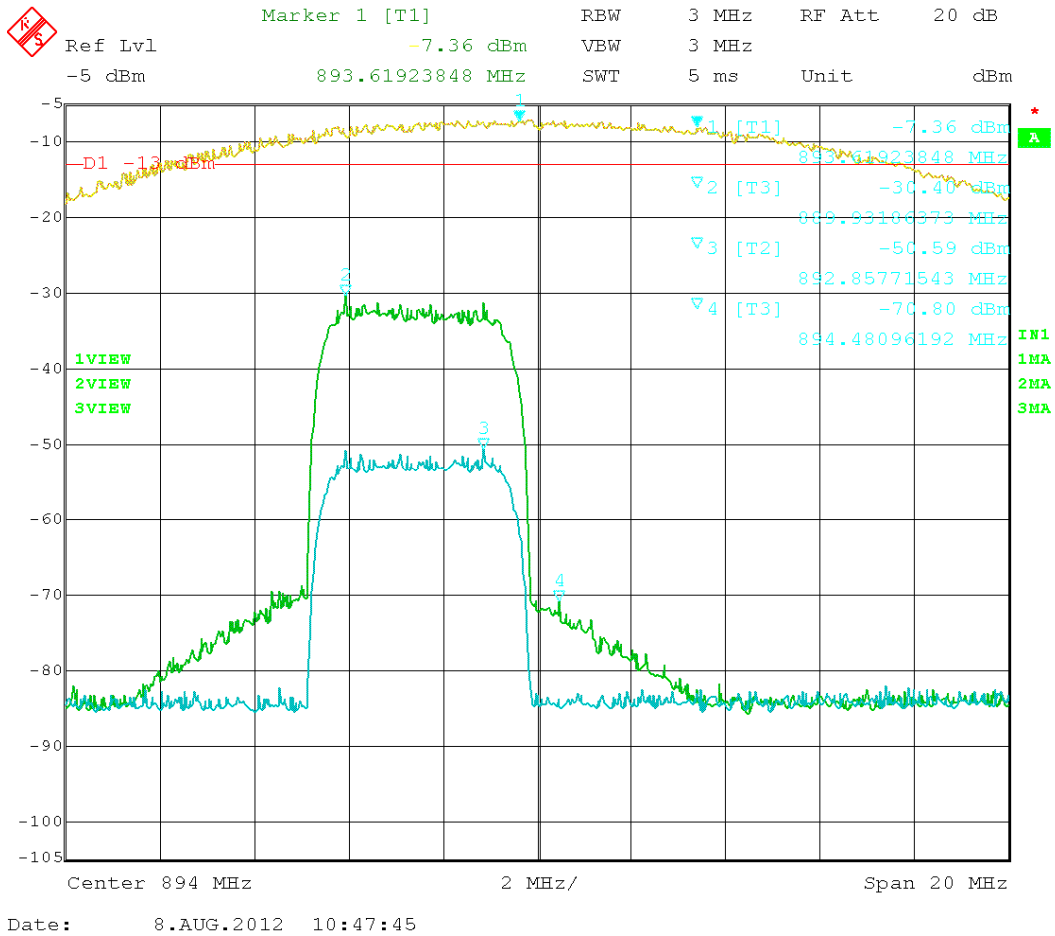

Figure 60: HSPA – In vs. Out 891.50 MHz

Test Data Table 18 – LTE 800 – Uplink/Downlink

Channel (MHz)	Band-edge Frequency (MHz)	Amplitude level at the band-edge (dBm)	Limit (dBm)	Margin (dB)
829.0	823.68	-27.28	-13	14.28
844.0	849.72	-27.60	-13	14.6
874.0	868.36	-63.76	-13	50.76
889.0	894.72	-65.69	-13	52.69

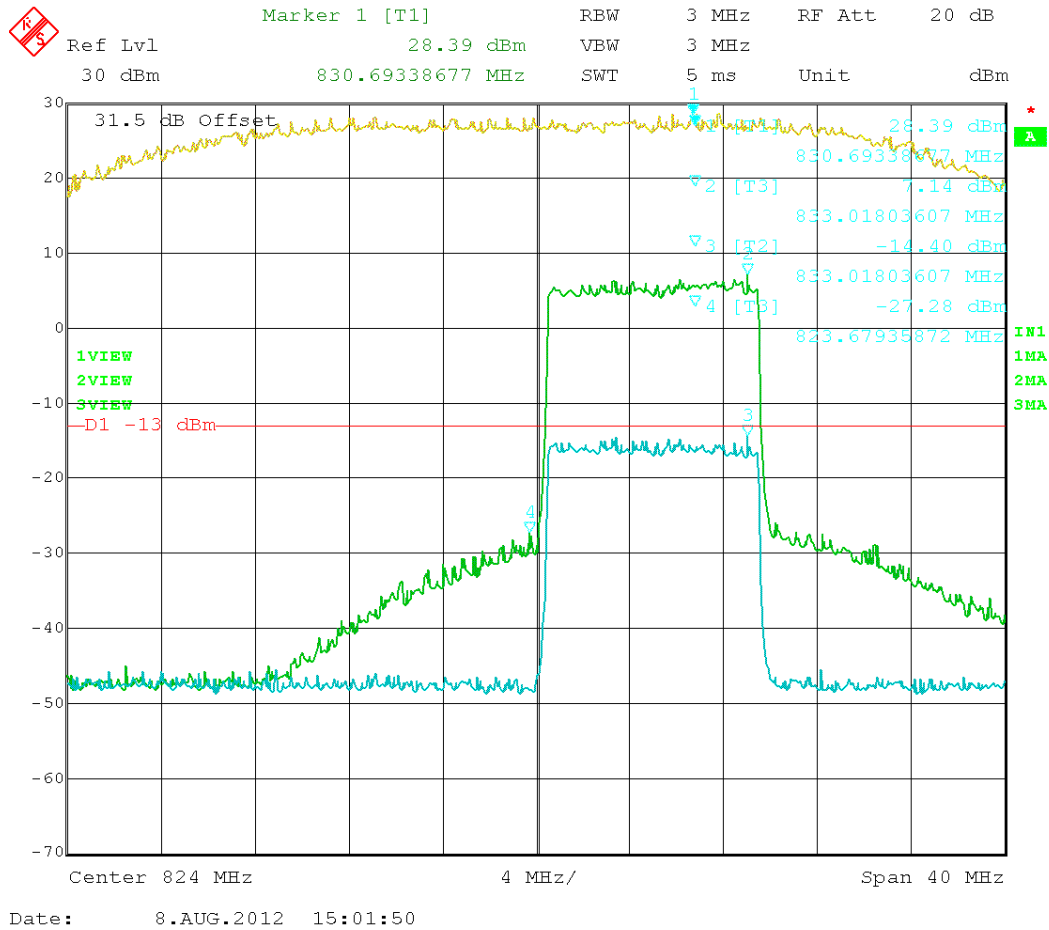

Figure 61: LTE – In vs. Out 829.00 MHz

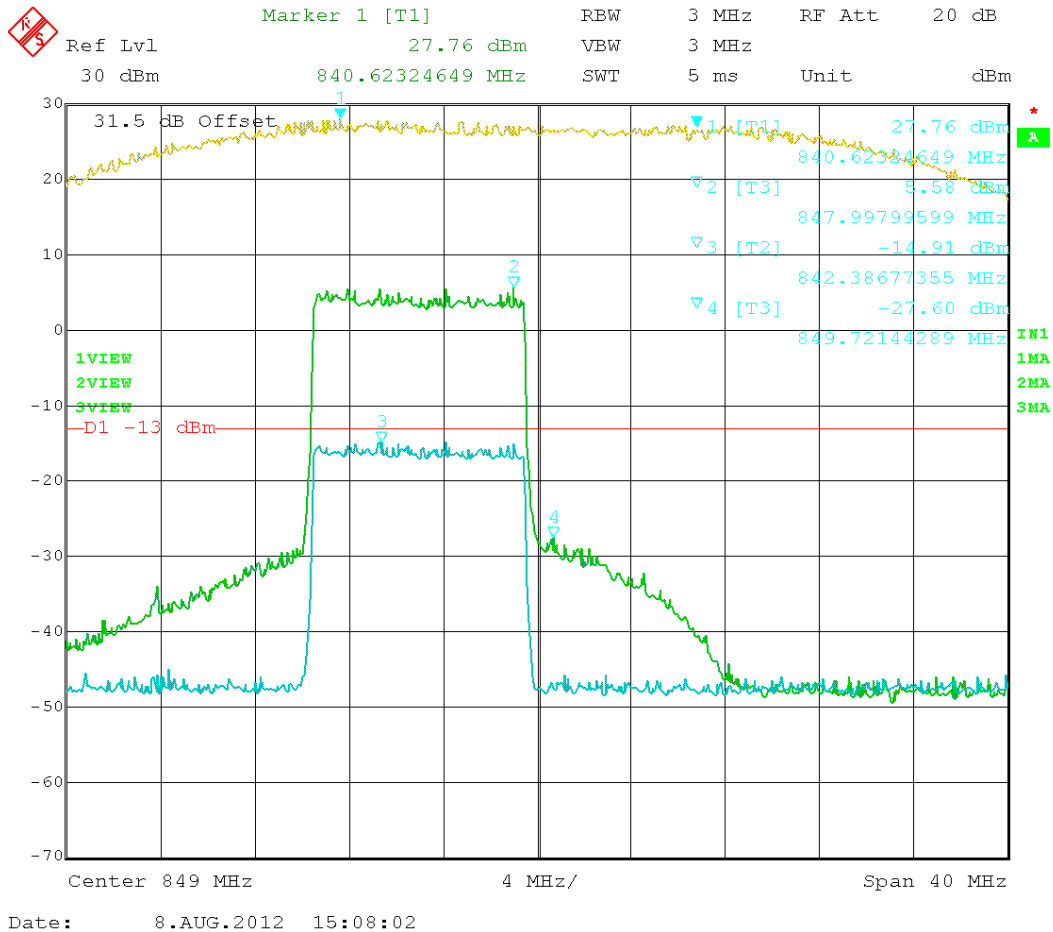

Figure 62: LTE – In vs. Out 844.00 MHz

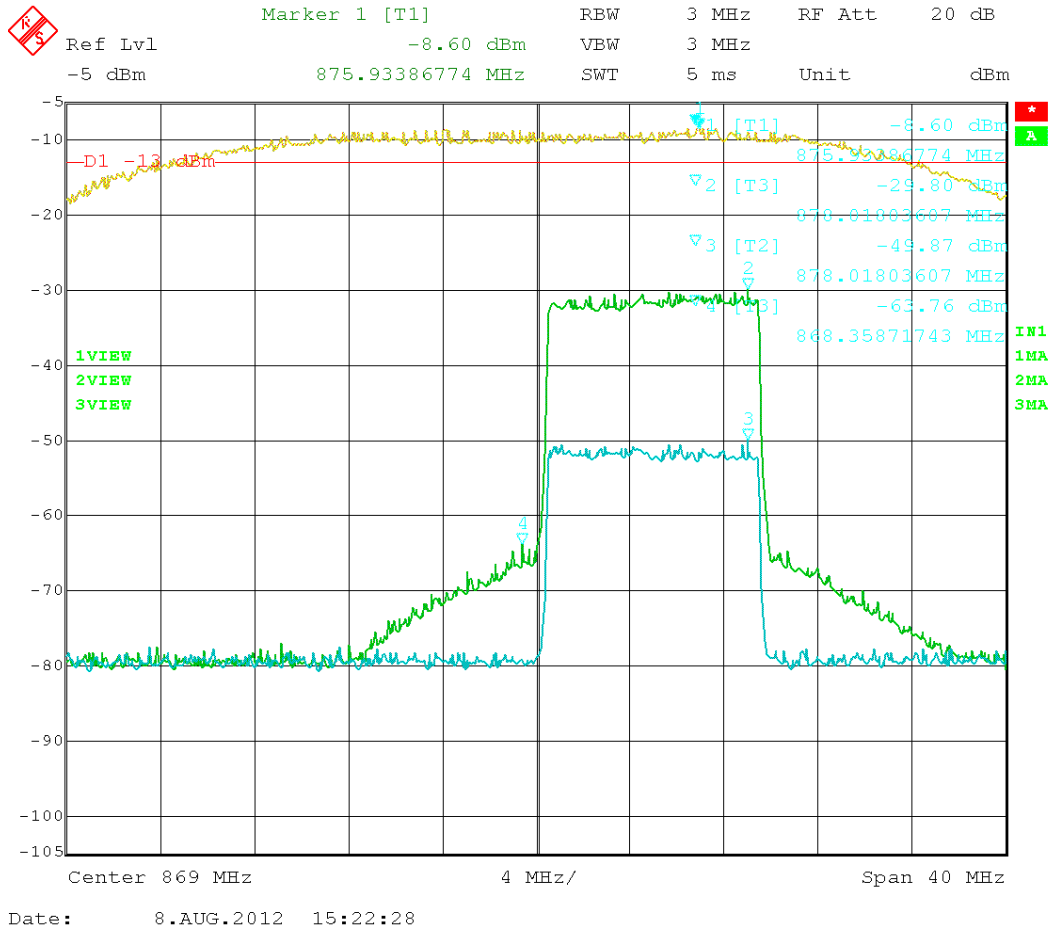

Figure 63: LTE – In vs. Out 874.00 MHz

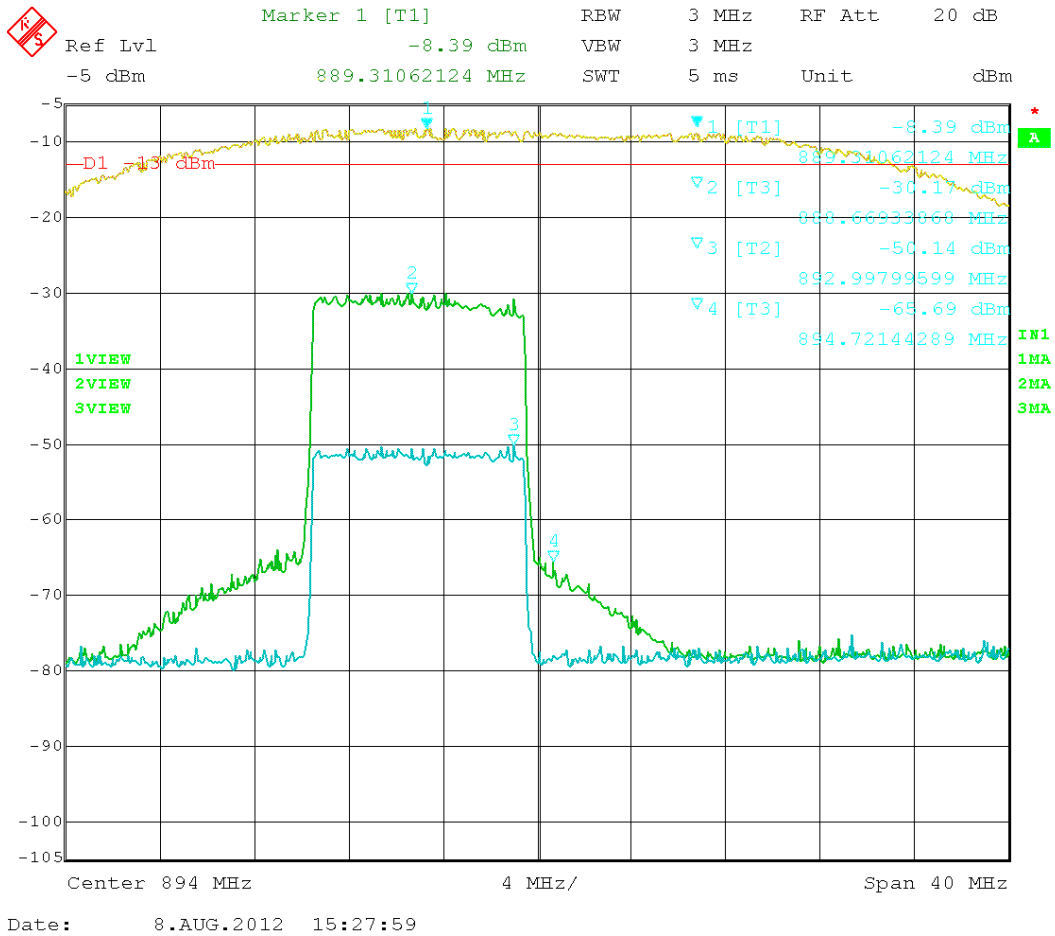

Figure 64: LTE – In vs. Out 889.00 MHz

Test Data Table 35 – GSM 800 – Uplink/Downlink

Channel (MHz)	Band-edge Frequency (MHz)	Amplitude level at the band-edge (dBm)	Limit (dBm)	Margin (dB)
824.2	823.98	-16.21	-13	3.21
848.8	849.02	-17.54	-13	4.54
869.2	868.98	-53.64	-13	40.64
893.8	894.02	-55.49	-13	42.49

The Reference level on the following plots was calibrated using a 3MHz RBW=VBW.

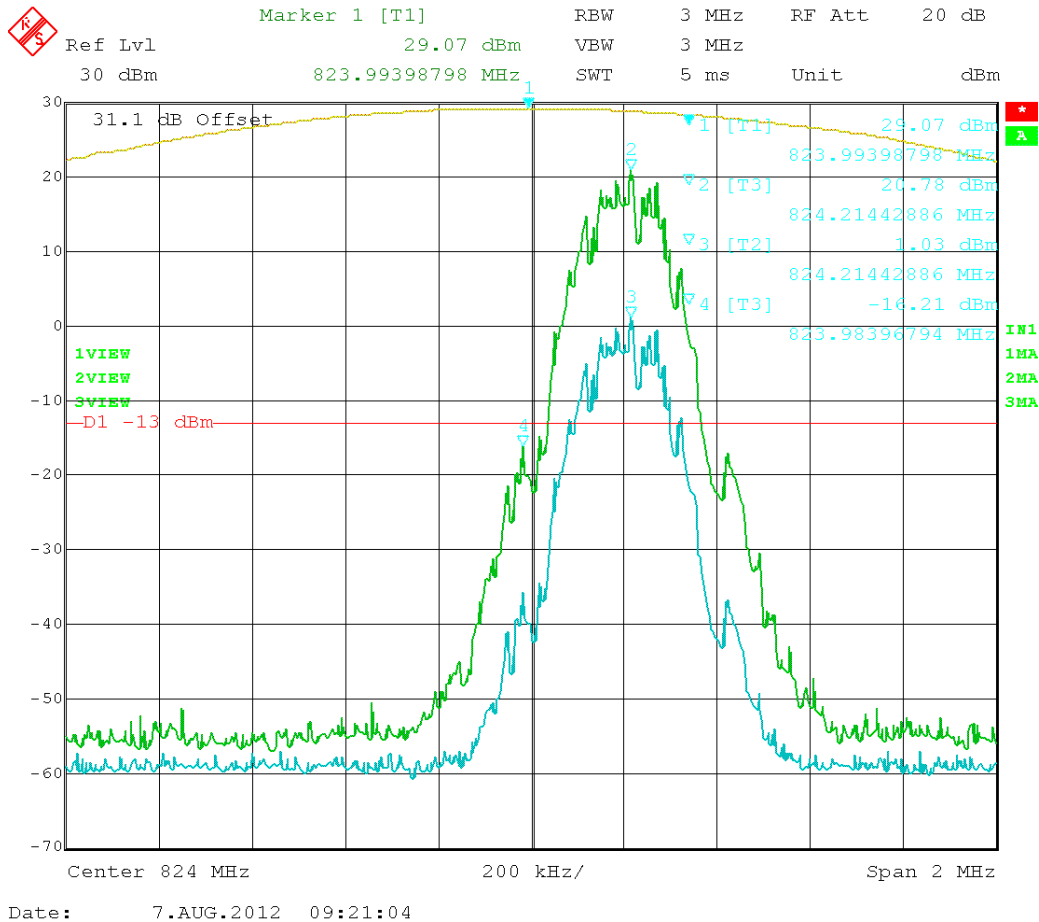

Figure 65: GSM – In vs. Out 824.2 MHz

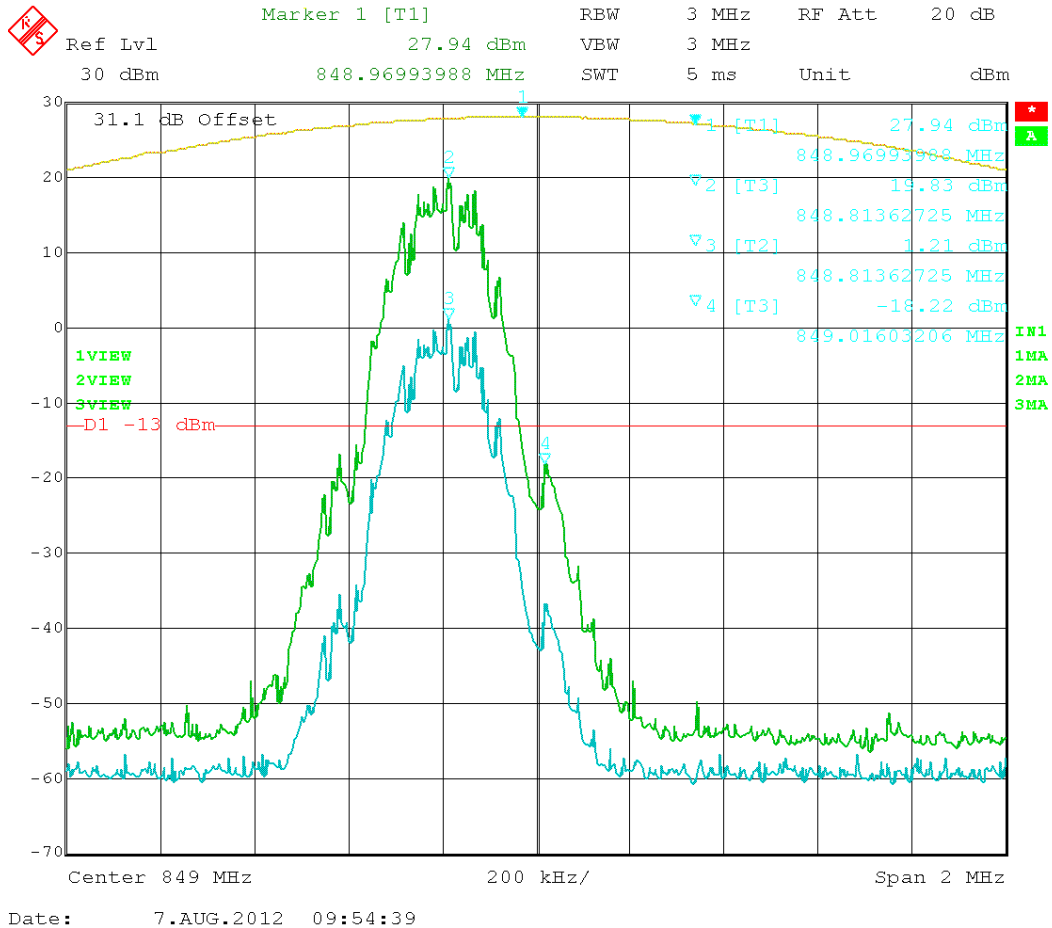

Figure 66: GSM – In vs. Out 848.8 MHz

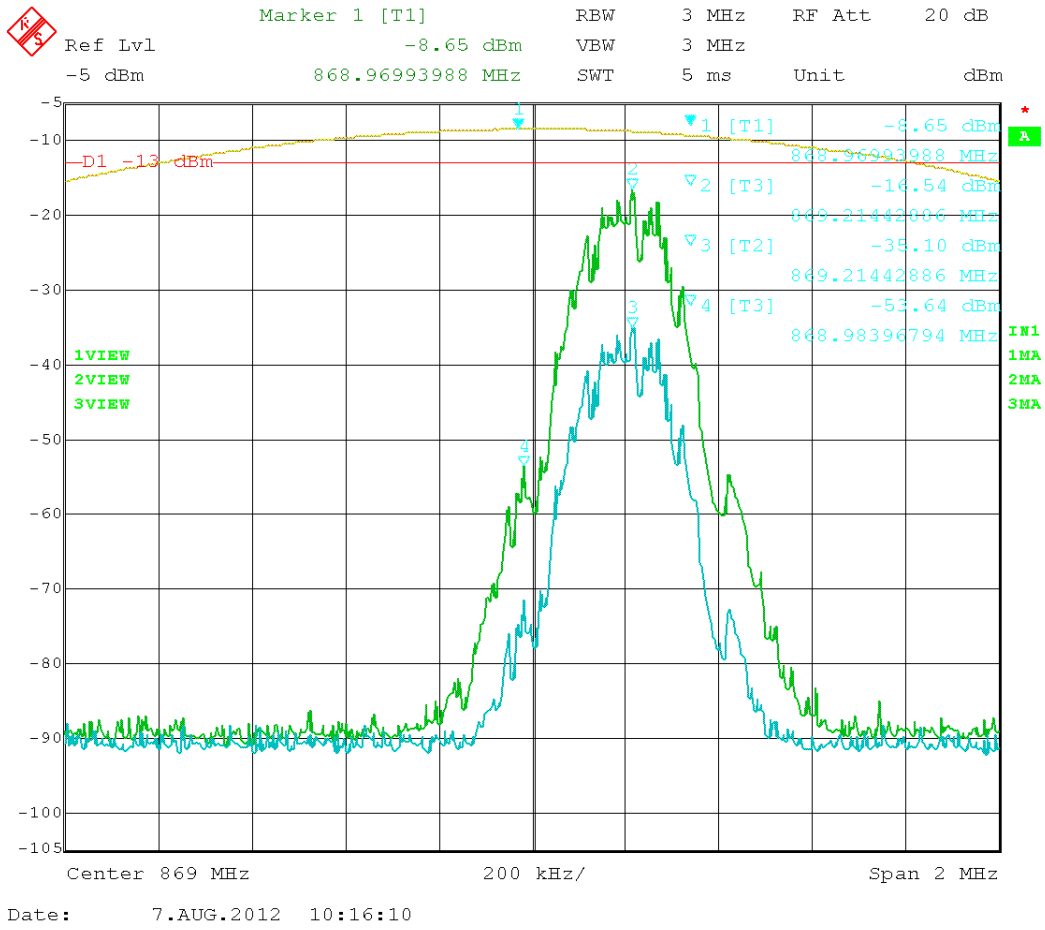

Figure 67: GSM – In vs. Out 869.2MHz

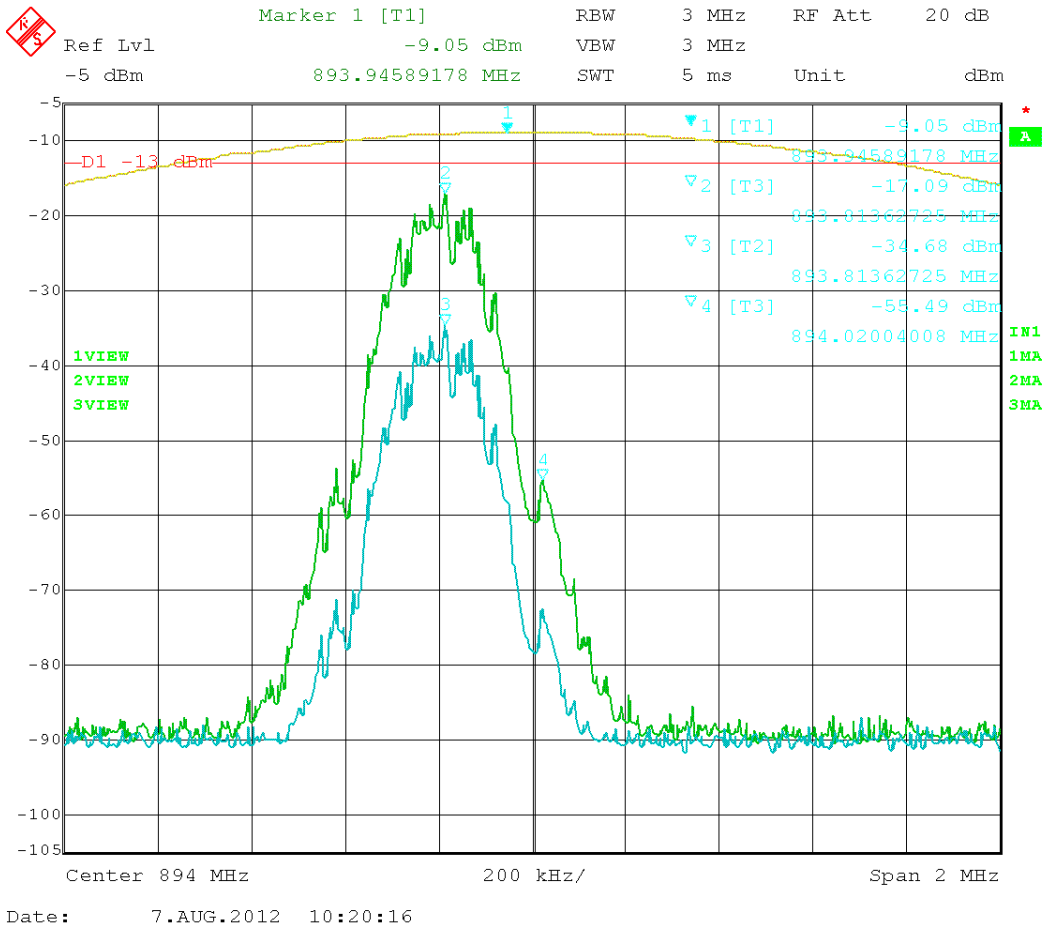

Figure 68: GSM – In vs. Out 893.8MHz

Test Data Table 36 – EDGE 800 – Uplink/Downlink

Channel (MHz)	Band-edge Frequency (MHz)	Amplitude level at the band-edge (dBm)	Limit (dBm)	Margin (dB)
824.2	823.98	-19.75	-13	6.75
848.8	849.02	-20.61	-13	7.61
869.2	868.98	-57.86	-13	44.86
893.8	894.02	-60.31	-13	47.31

The Reference level on the following plots was calibrated using a 3MHz RBW=VBW.

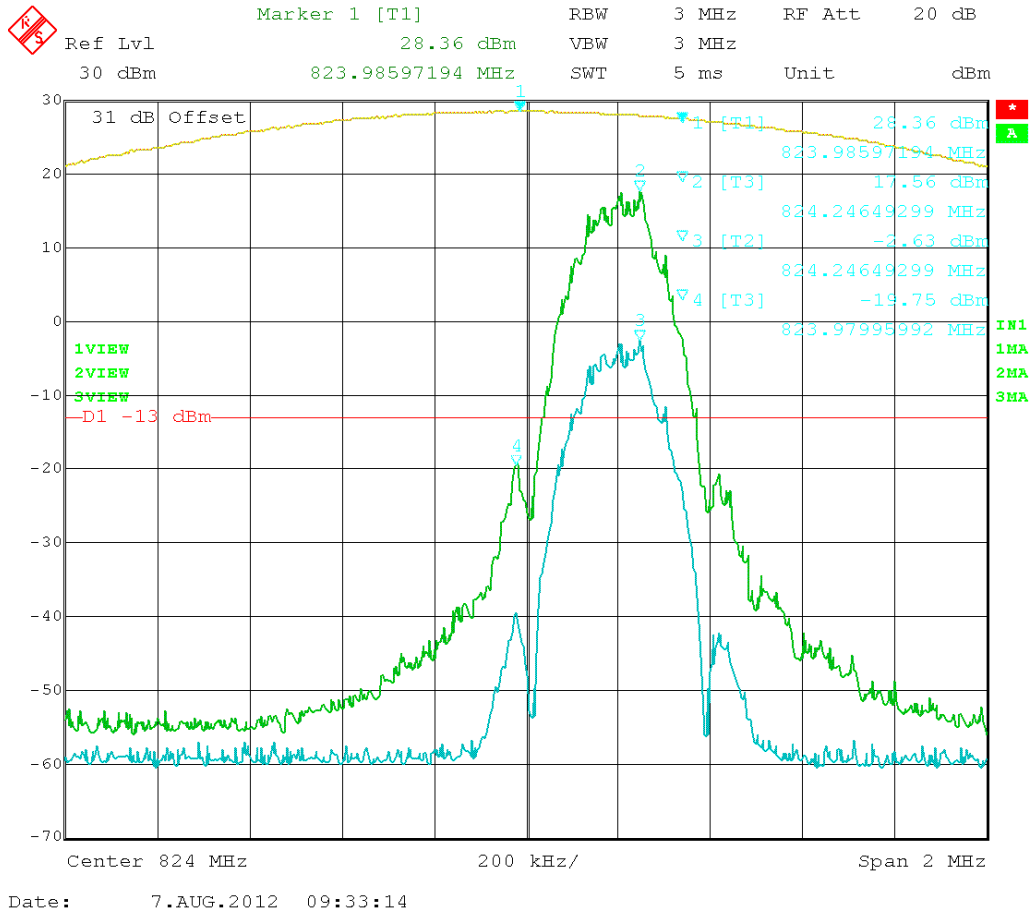

Figure 69: EDGE – In vs. Out 824.20 MHz

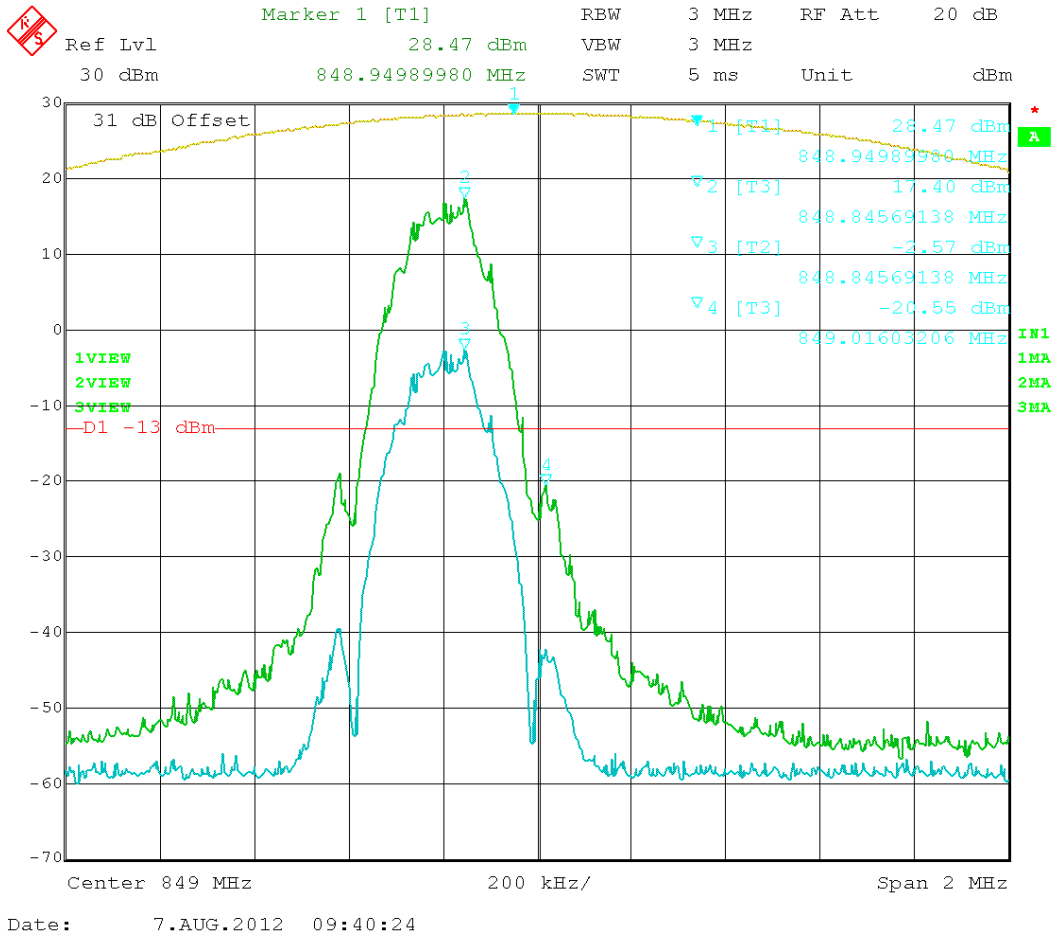

Figure 70: EDGE – In vs. Out 848.80 MHz

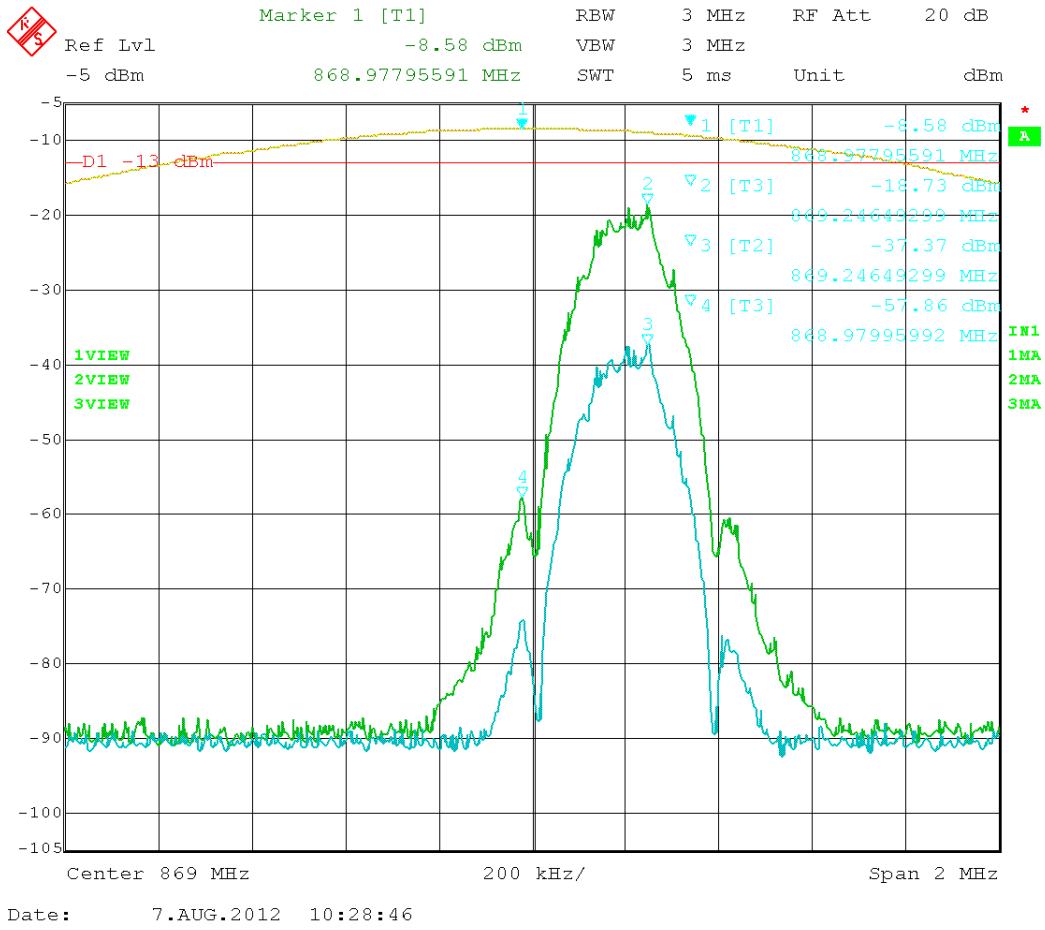
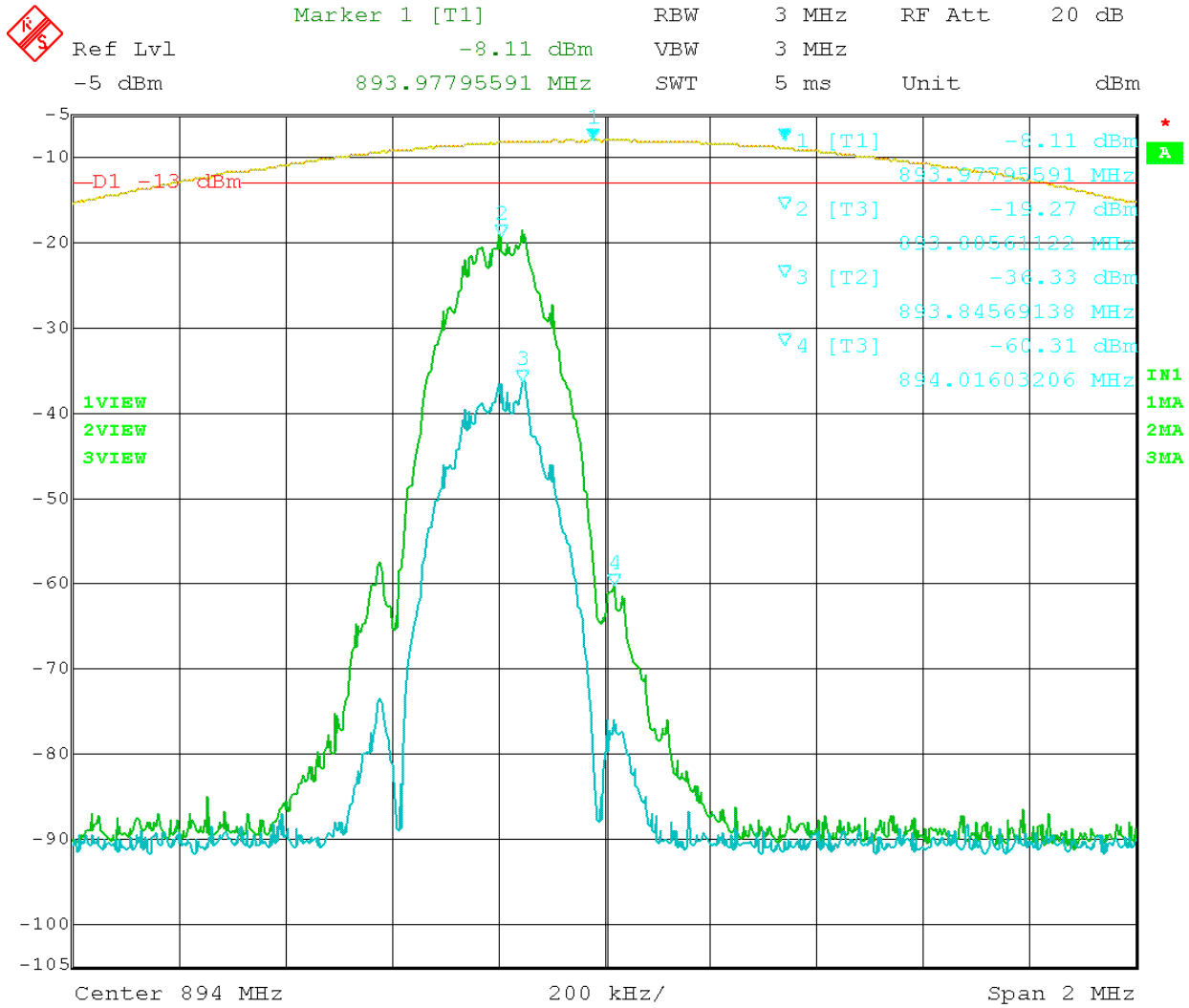

Figure 71: EDGE – In vs. Out 869.20 MHz



Date: 7.AUG.2012 10:24:37

Figure 72: EDGE – In vs. Out 893.80 MHz

INTERMODULATION PRODUCT SPURIOUS EMISSIONS

Rule Parts No.: Pt 2.1051

Requirements: Emissions must be $43 + 10 \log (P_o)$ dB below the mean power output of the transmitter or below the -13dBm

All the modulation types were tested using the three tone test method. A CW signal was use instead of GSM, EDGE, and F1D modulations. EDGE and GSM provided the same test results and only GSM data are presented in this report. The input power to the amplifier was set at maximum drive level by combining the three tones. The three tones were chosen in such a way (1)the third order intermodulation product frequencies are located within the pass band of the DUT and (2) they produce the worst-case emissions out of band.

Test Data: The DUT meets the requirements.

1900 MHz

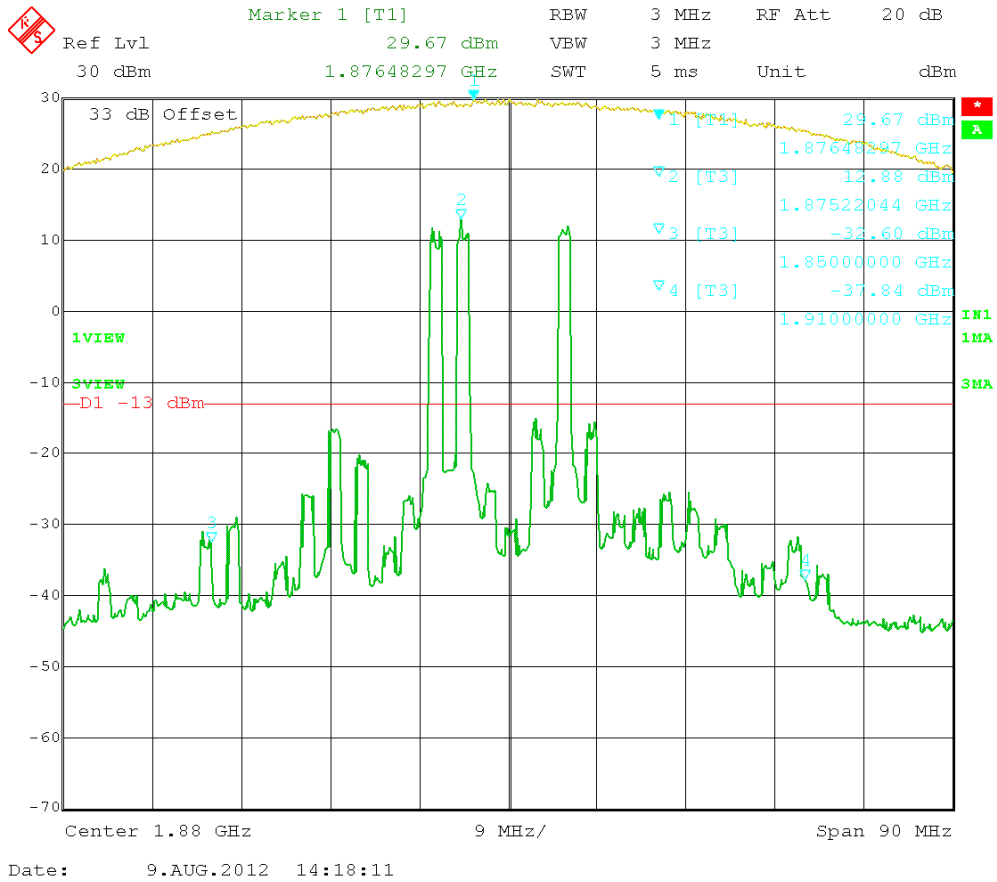

Figure 73: CDMA 3 tones intermodulation - (1850 – 1910) MHz.

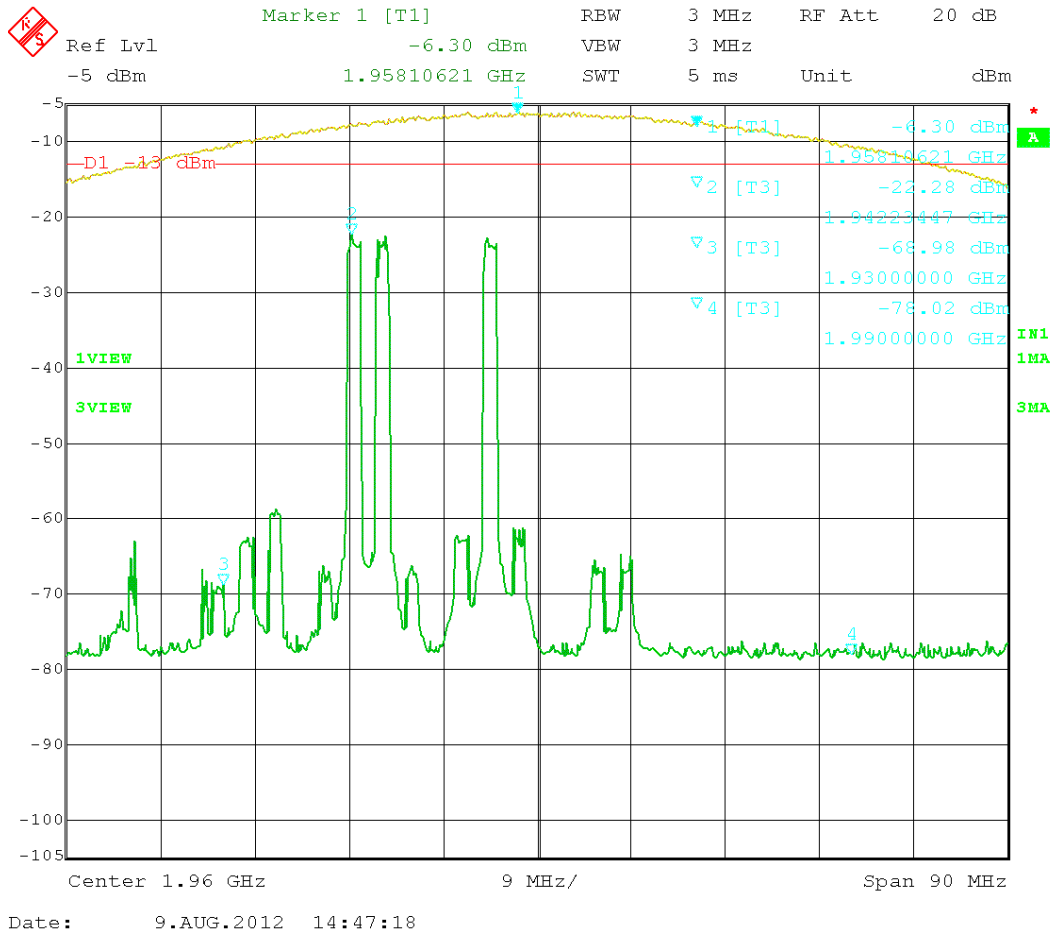

Figure 74: CDMA 3 tones intermodulation - (1930 – 1990) MHz.

1700 MHz

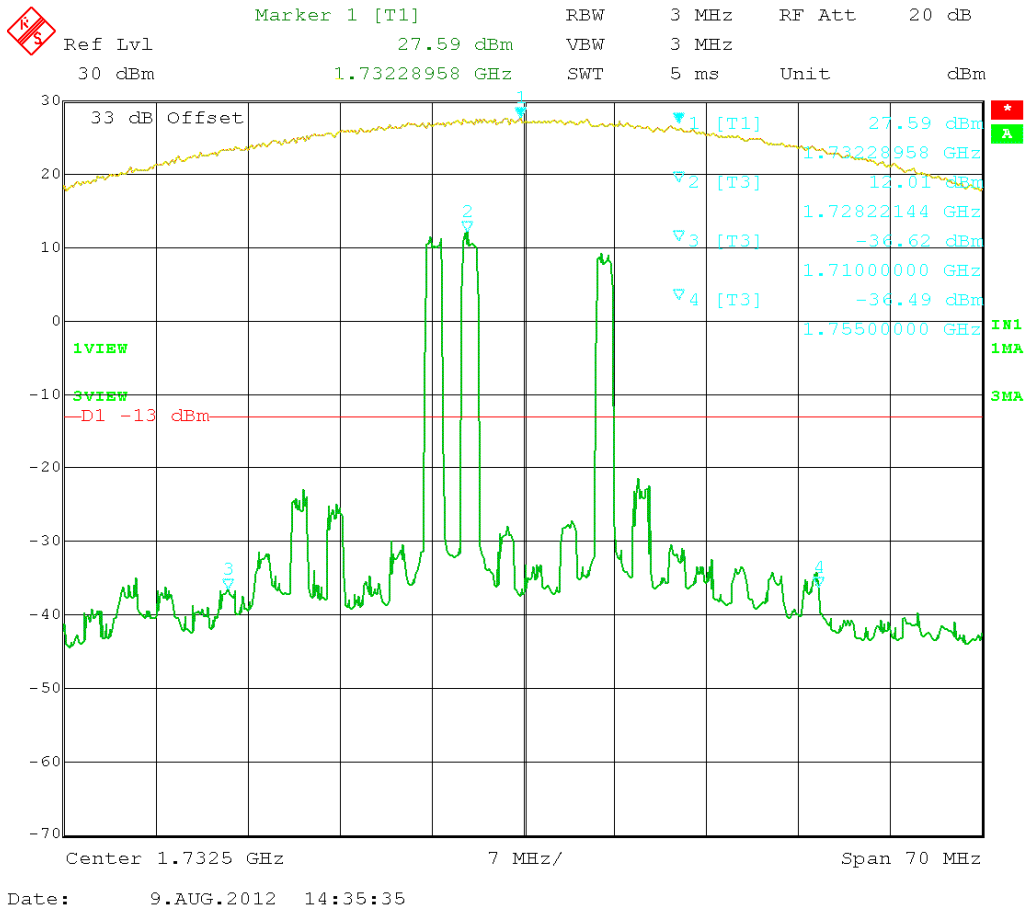

Figure 75: CDMA 3 tones intermodulation - (1710 – 1755) MHz.

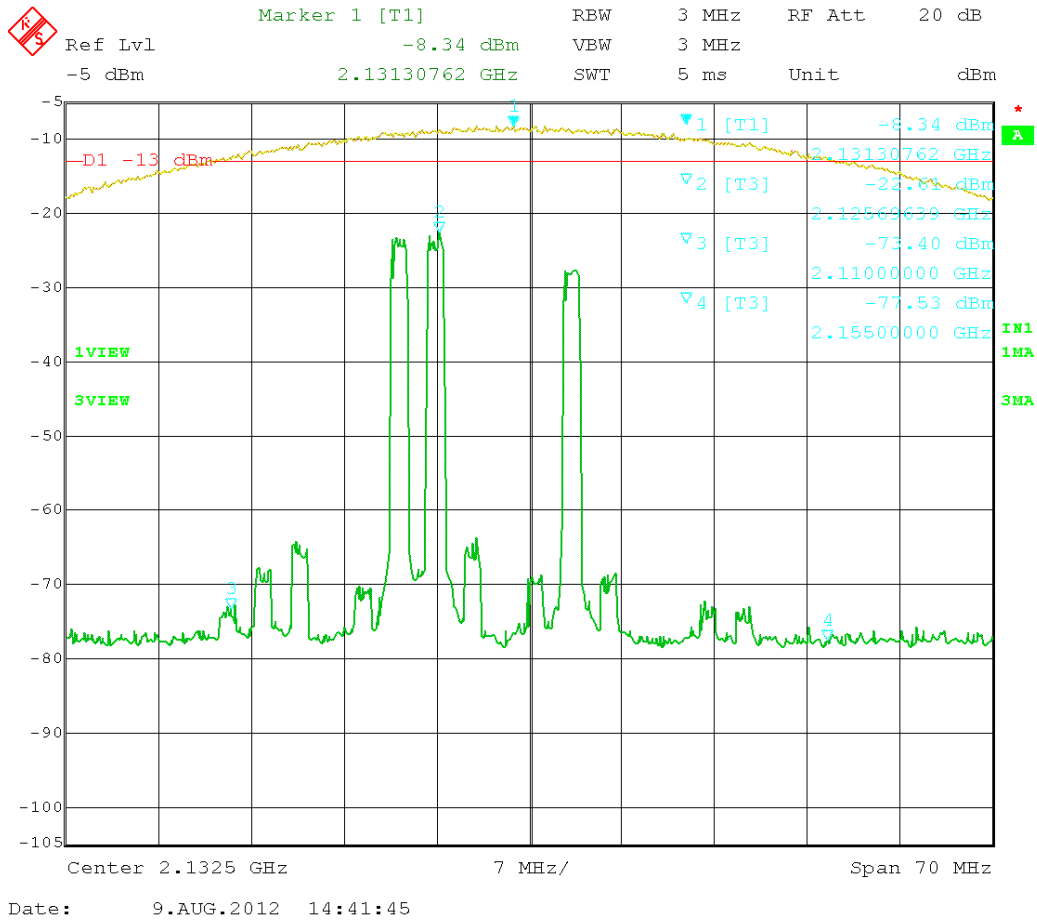

Figure 76: CDMA 3 tones intermodulation - (2110 – 2155) MHz.

800 MHz

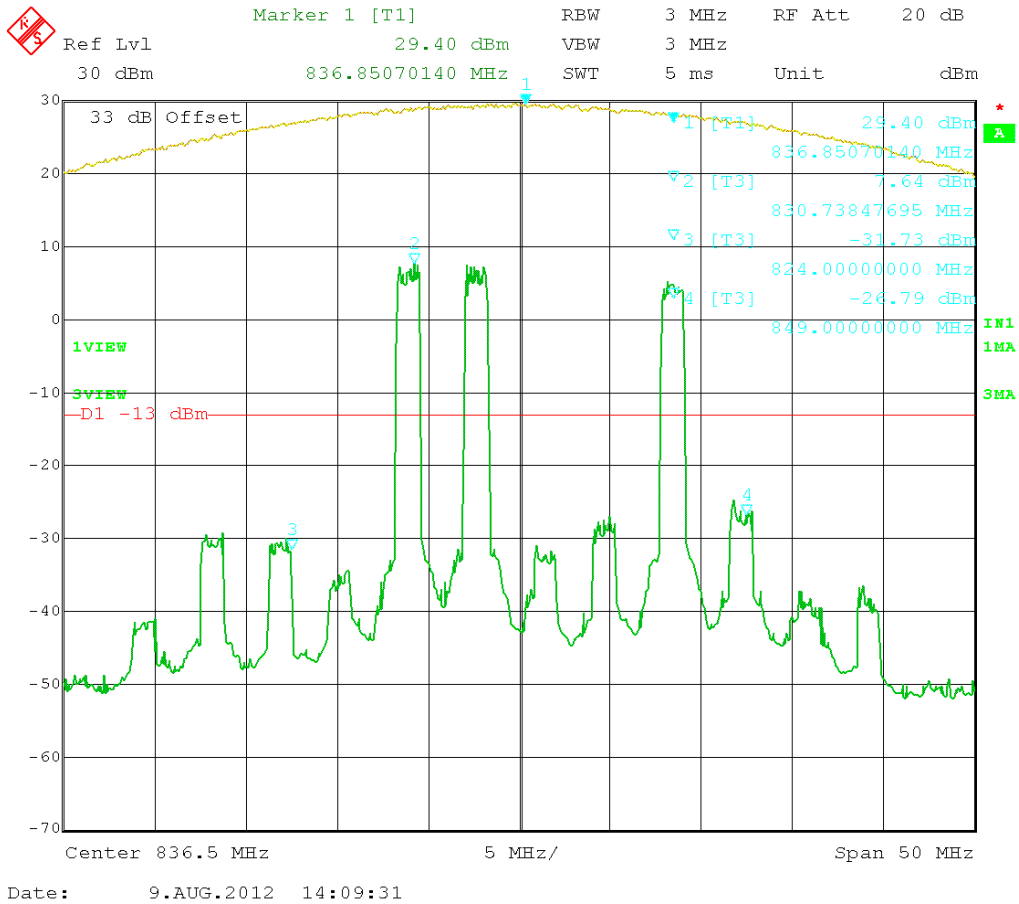

Figure 77: CDMA 3 tones intermodulation – (824 – 849) MHz.

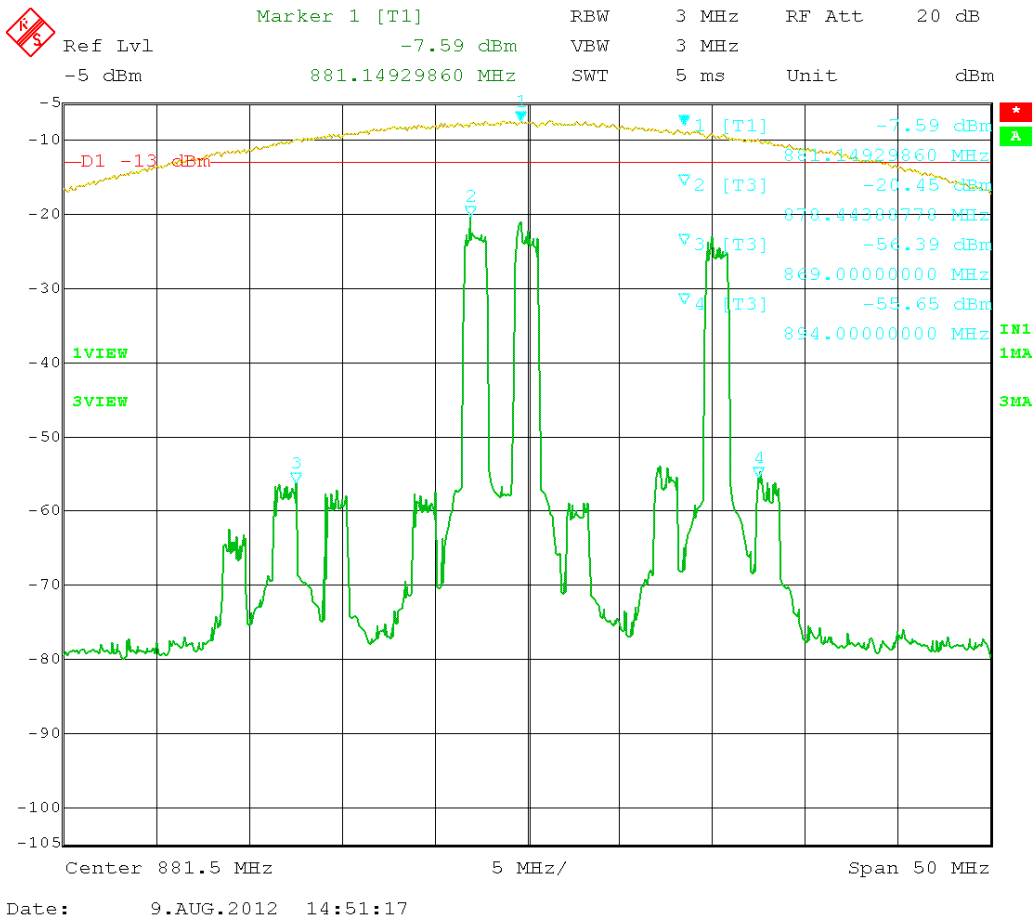

Figure 78: CDMA 3 tones intermodulation - (869 – 894) MHz.

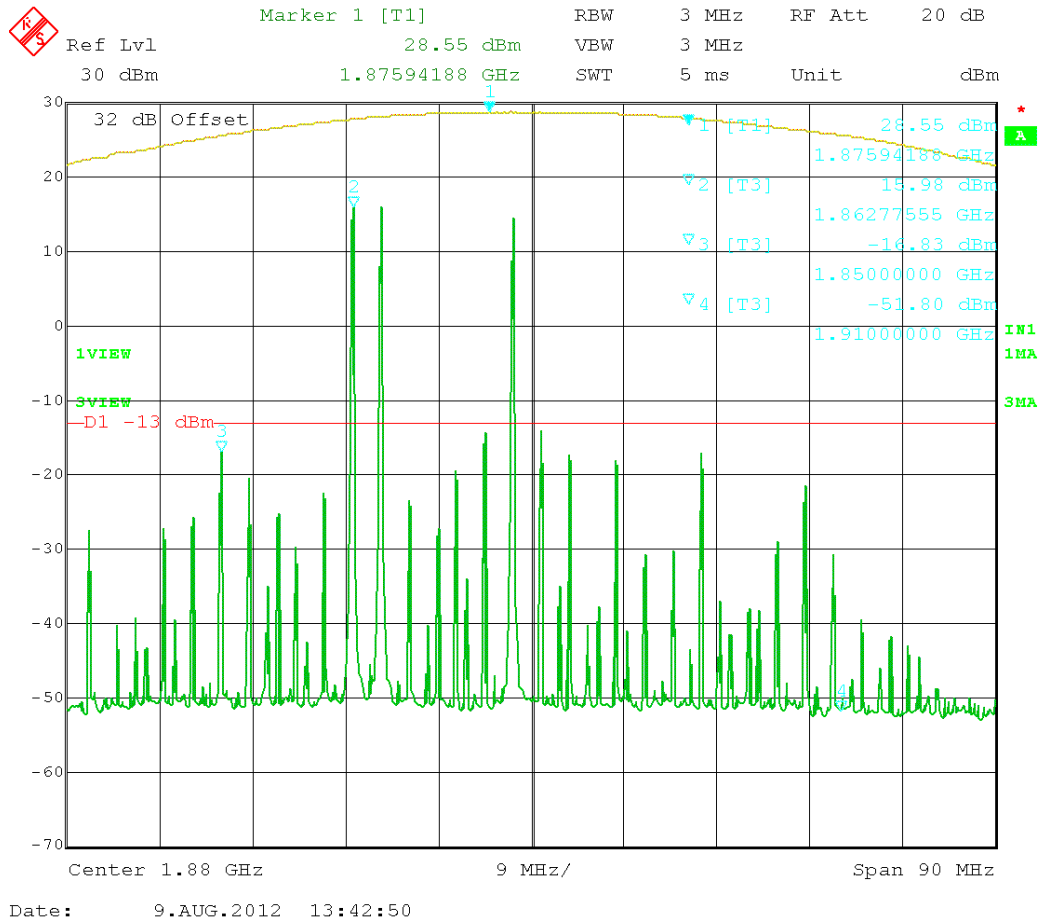

Figure 79: GSM 3 tones intermodulation - (1850 – 1910) MHz

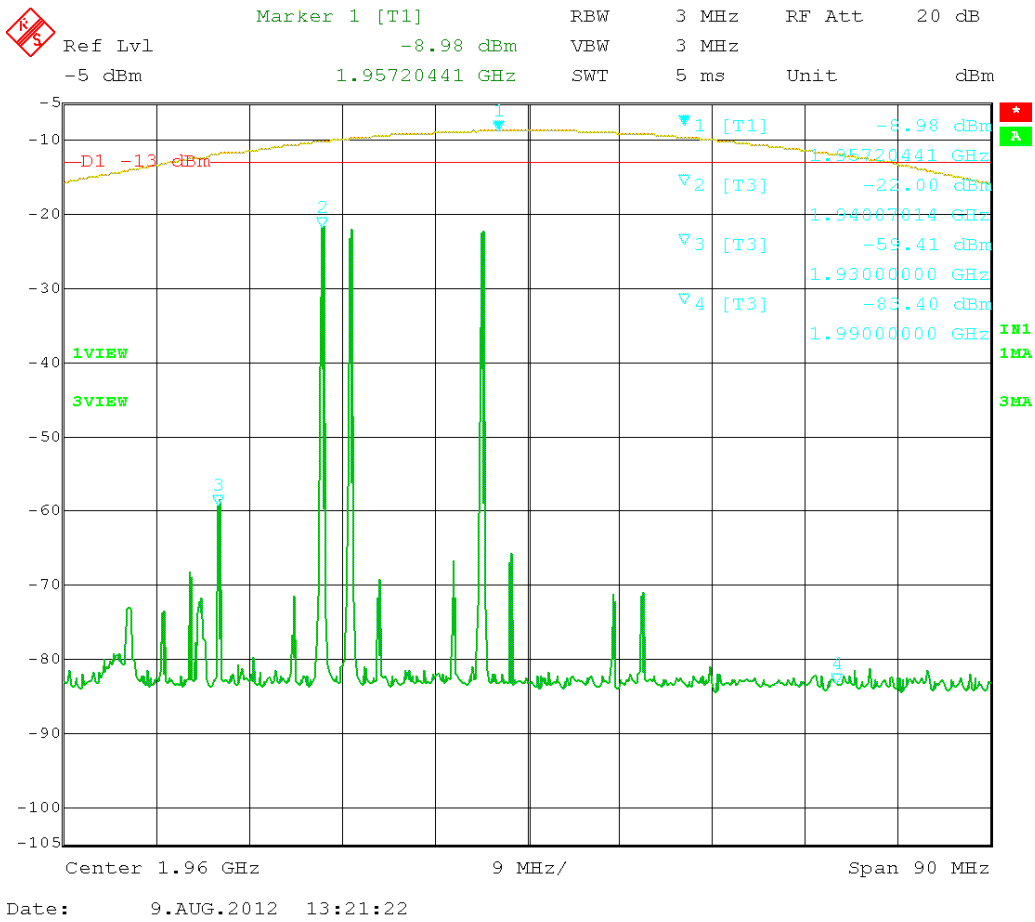

Figure 80: GSM 3 tones intermodulation - (1930 – 1990) MHz

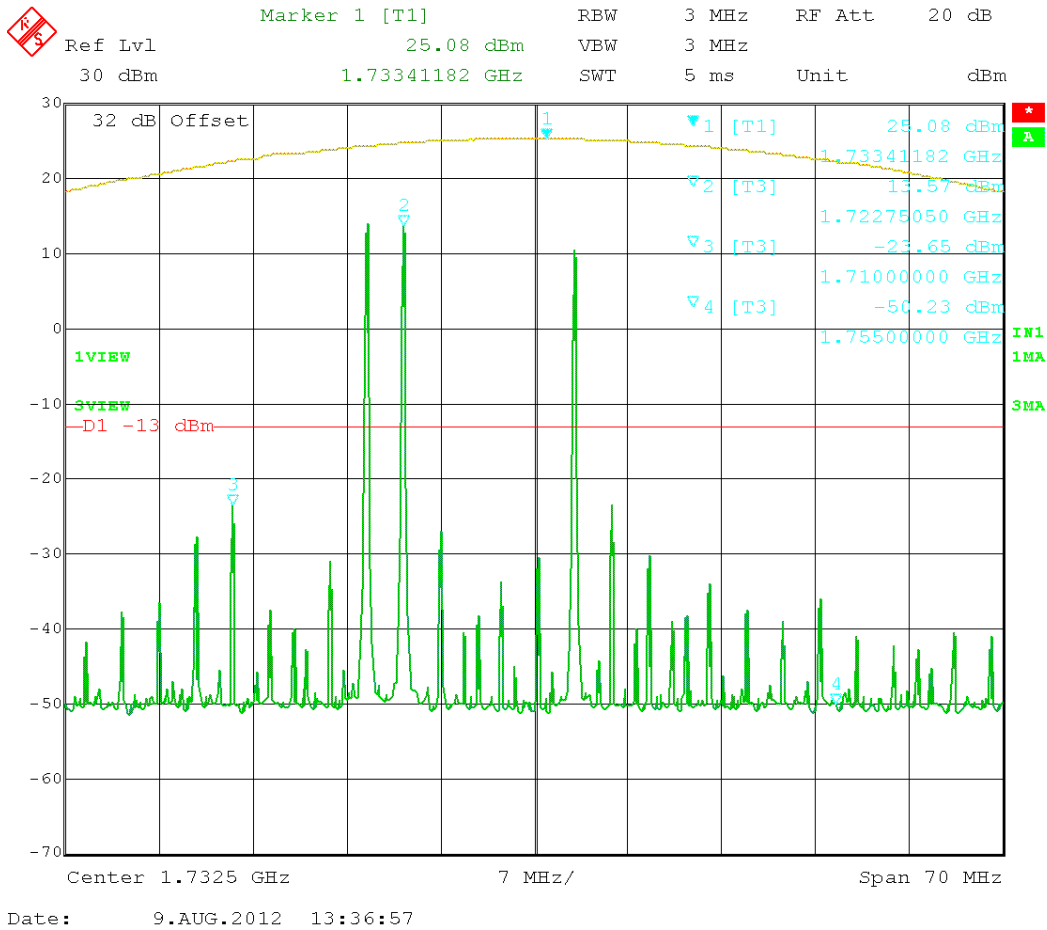

Figure 81: GSM 3 tones intermodulation - (1710 – 1755) MHz

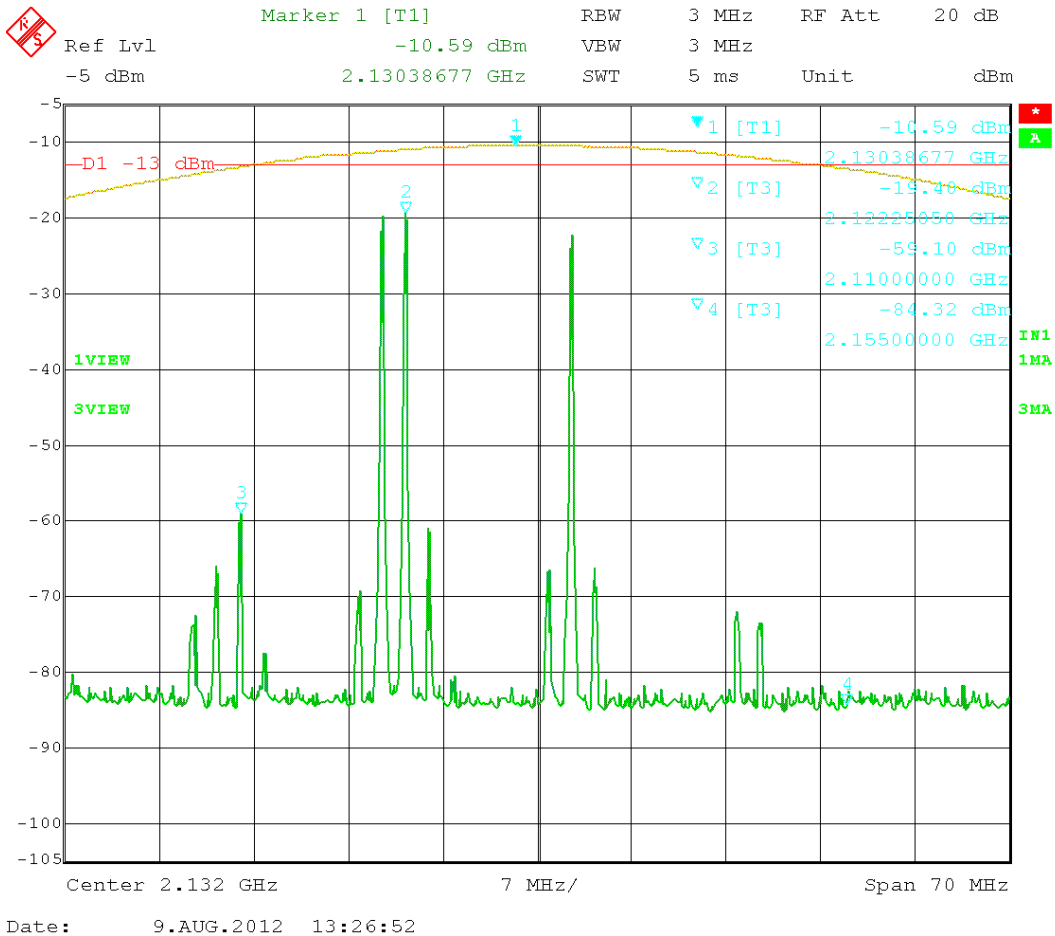

Figure 82: GSM 3 tones intermodulation - (2110 – 2155) MHz

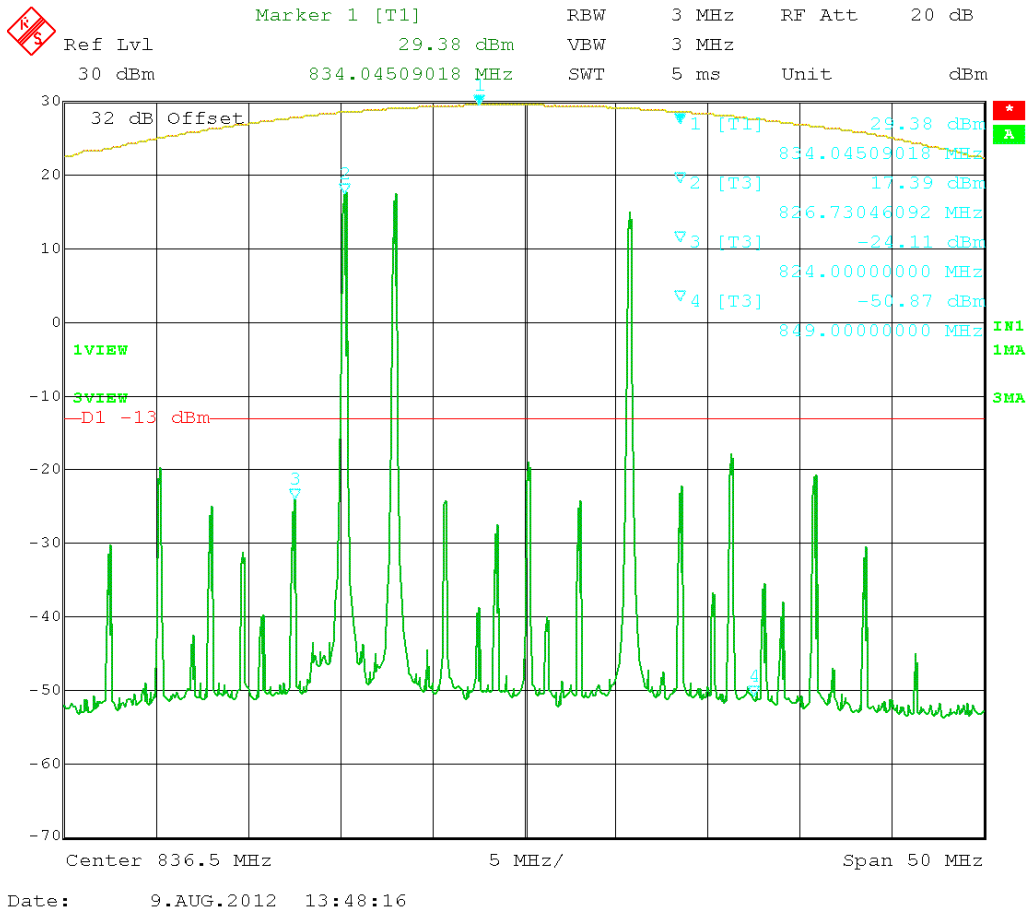

Figure 83: GSM 3 tones intermodulation - (824 – 849) MHz

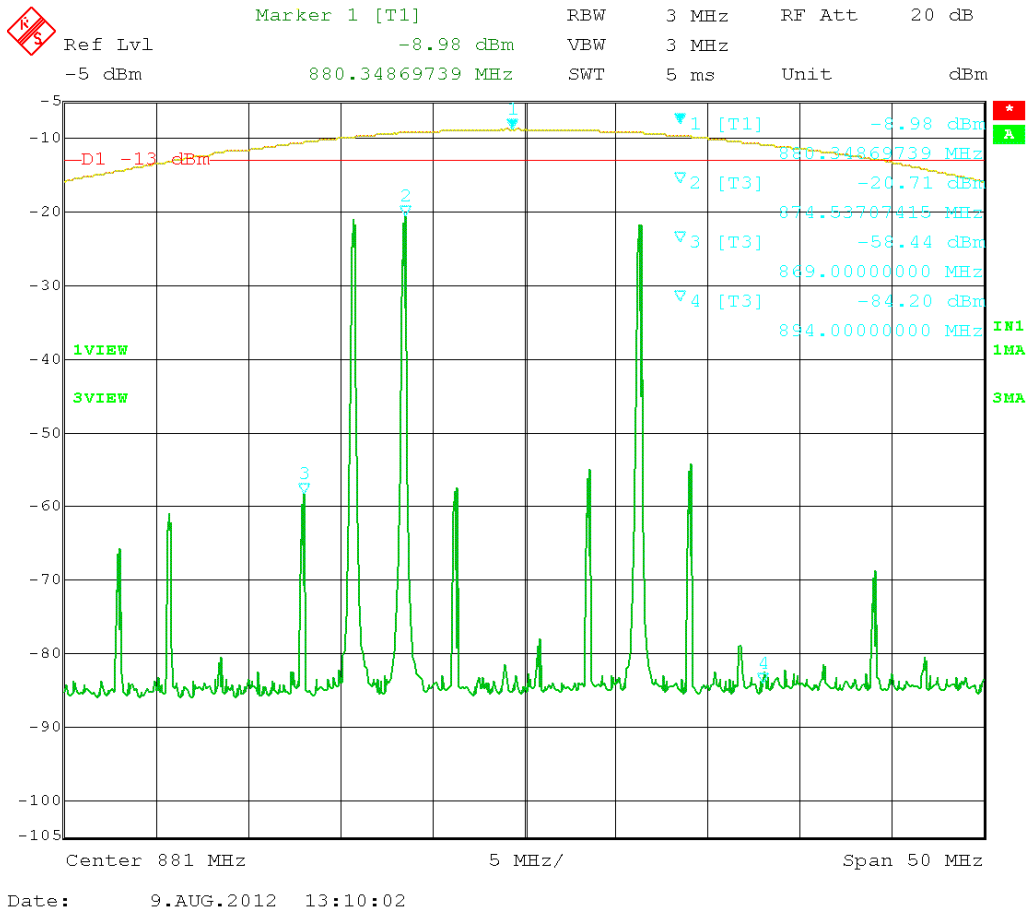

Figure 84: GSM 3 tones intermodulation - (869 – 894) MHz

SPURIOUS EMISSIONS AT ANTENNA TERMINALS

Rule Parts No.: Pt 2.1051

Requirements: Emissions must be $43 + 10\log(P_o)$ dB below the mean power output of the transmitter:

$$1850 - 1910 \text{ MHz: } 43 + 10\log(1.20) = 43.8 \text{ dBc}$$

$$1930 - 1990: 43 + 10\log(0.01) = 23.0 \text{ dBc}$$

Test Result: The DUT meets the requirements.

Test Data Table 37 – Conducted Emissions – CDMA 1900 – Uplink

Emission Frequency MHz	dB Below Carrier (dBc)	Emission Frequency MHz	dB Below Carrier (dBc)	Emission Frequency MHz	dB Below Carrier (dBc)
1851.25		1880.00		1908.75	
3702.50	78.9	3760.00	74.7	3817.50	76.9
5553.75	77.0	5640.00	77.5	5726.25	75.6
7405.00	76.7	7520.00	78.5	7635.00	76.5
9256.25	79.2	9400.00	79.6	9543.75	77.1
11107.50	NF	11280.00	NF	11452.50	NF
12958.75	NF	13160.00	NF	13361.25	NF
14810.00	NF	15040.00	NF	15270.00	NF
16661.25	NF	16920.00	NF	17178.75	NF
18512.50	NF	18800.00	NF	19087.50	NF

Test Data Table 38 – Conducted Emissions – CDMA 1900 – Downlink

Emission Frequency MHz	dB Below Carrier (dBc)	Emission Frequency MHz	dB Below Carrier (dBc)	Emission Frequency MHz	DB Below Carrier (dBc)
1931.25		1960.00		1988.75	
3862.50	64.3	3920.00	65.7	3977.50	61.1
5793.75	61.6	5880.00	64.1	5966.25	63.3
7725.00	63.7	7840.00	63.8	7955.00	61.1
9656.25	63.8	9800.00	65.1	9943.75	62.2
11587.50	NF	11760.00	NF	11932.50	NF
13518.75	NF	13720.00	NF	13921.25	NF
15450.00	NF	15680.00	NF	15910.00	NF
17381.25	NF	17640.00	NF	17898.75	NF
19312.50	NF	19600.00	NF	19887.50	NF

APPLICANT: WILSON ELECTRONICS, INC.

FCC ID: PWO2B2725

Report #: W\WILSON_PWO\1851AUT12\1851AUT12TestReport.doc

Test Data Table 39 – Conducted Emissions – GSM 1900 - Uplink

Emission Frequency MHz	dB Below Carrier (dBc)	Emission Frequency MHz	dB Below Carrier (dBc)	Emission Frequency MHz	dB Below Carrier (dBc)
1850.20		1880.00		1909.80	
3700.40	79.7	3760.00	74.6	3819.60	74.7
5550.60	81.5	5640.00	82.1	5729.40	79.1
7400.80	81.7	7520.00	82.7	7639.20	80.3
9251.00	82.2	9400.00	84.3	9549.00	79.9
11101.20	NF	11280.00	NF	11458.80	NF
12951.40	NF	13160.00	NF	13368.60	NF
14801.60	NF	15040.00	NF	15278.40	NF
16651.80	NF	16920.00	NF	17188.20	NF
18502.00	NF	18800.00	NF	19098.00	NF

Test Data Table 40 – Conducted Emissions – GSM 1900 - Downlink

Emission Frequency MHz	dB Below Carrier (dBc)	Emission Frequency MHz	dB Below Carrier (dBc)	Emission Frequency MHz	dB Below Carrier (dBc)
1930.20		1960.00		1989.80	
3860.40	76.6	3920.00	78.5	3979.60	76.4
5790.60	74.1	5880.00	76.4	5969.40	74.2
7720.80	75.0	7840.00	74.4	7959.20	74.1
9651.00	74.1	9800.00	76.0	9949.00	73.0
11581.20	NF	11760.00	NF	11938.80	NF
13511.40	NF	13720.00	NF	13928.60	NF
15441.60	NF	15680.00	NF	15918.40	NF
17371.80	NF	17640.00	NF	17908.20	NF
19302.00	NF	19600.00	NF	19898.00	NF

Requirements: Emissions must be $43 + 10\log(P_o)$ dB below the mean power output of the transmitter:

$$1710 - 1755 \text{ MHz: } 43 + 10\log(1.00) = 43 \text{ dBc}$$

$$2110 - 2155 \text{ MHz: } 43 + 10\log(0.001) = 13 \text{ dBc}$$

Test Result: The DUT meets the requirements

Test Data Table 41 – Conducted Emissions – CDMA 1700 - Uplink

Emission Frequency MHz	dB Below Carrier (dBc)	Emission Frequency MHz	dB Below Carrier (dBc)	Emission Frequency MHz	dB Below Carrier (dBc)
1711.25		1732.50		1753.75	
3422.50	66.4	3465.00	74.8	3507.50	76.5
5133.75	81.4	5197.50	82.0	5261.25	78.9
6845.00	77.7	6930.00	77.3	7015.00	76.2
8556.25	79.7	8662.50	80.0	8768.75	77.2
10267.50	NF	10395.00	NF	10522.50	NF
11978.75	NF	12127.50	NF	12276.25	NF
13690.00	NF	13860.00	NF	14030.00	NF
15401.25	NF	15592.50	NF	15783.75	NF
17112.50	NF	17325.00	NF	17537.50	NF

Test Data Table 42 – Conducted Emissions – CDMA 1700 - Downlink

Emission Frequency MHz	dB Below Carrier (dBc)	Emission Frequency MHz	dB Below Carrier (dBc)	Emission Frequency MHz	dB Below Carrier (dBc)
2111.25		2132.50		2153.75	
4222.50	60.0	4265.00	59.7	4307.50	58.2
6333.75	59.2	6397.50	56.7	6461.25	54.3
8445.00	58.9	8530.00	57.4	8615.00	54.9
10556.25	57.7	10662.50	56.6	10768.75	54.6
12667.50	NF	12795.00	NF	12922.50	NF
14778.75	NF	14927.50	NF	15076.25	NF
16890.00	NF	17060.00	NF	17230.00	NF
19001.25	NF	19192.50	NF	19383.75	NF
21112.50	NF	21325.00	NF	21537.50	NF

Test Data Table 43 – Conducted Emissions – GSM 1700 – Uplink

Emission Frequency MHz	dB Below Carrier (dBc)	Emission Frequency MHz	dB Below Carrier (dBc)	Emission Frequency MHz	dB Below Carrier (dBc)
1710.20		1732.50		1754.80	
3420.40	66.8	3465.00	71.2	3509.60	75.8
5130.60	81.6	5197.50	81.2	5264.40	78.6
6840.80	78.0	6930.00	76.5	7019.20	76.4
8551.00	80.3	8662.50	79.7	8774.00	75.4
10261.20	NF	10395.00	NF	10528.80	NF
11971.40	NF	12127.50	NF	12283.60	NF
13681.60	NF	13860.00	NF	14038.40	NF
15391.80	NF	15592.50	NF	15793.20	NF
17102.00	NF	17325.00	NF	17548.00	NF

Test Data Table 44 – Conducted Emissions – GSM 1700 - Downlink

Emission Frequency MHz	dB Below Carrier (dBc)	Emission Frequency MHz	dB Below Carrier (dBc)	Emission Frequency MHz	dB Below Carrier (dBc)
2110.20		2132.50		2154.80	
4220.40	60.8	4265.00	60.4	4309.60	57.5
6330.60	57.9	6397.50	57.4	6464.40	54.8
8440.80	58.4	8530.00	59.2	8619.20	55.6
10551.00	58.2	10662.50	58.6	10774.00	55.9
12661.20	97.6	12795.00	97.9	12928.80	95.3
14771.40	NF	14927.50	NF	15083.60	NF
16881.60	NF	17060.00	NF	17238.40	NF
18991.80	NF	19192.50	NF	19393.20	NF
21102.00	NF	21325.00	NF	21548.00	NF

APPLICANT: WILSON ELECTRONICS, INC.

FCC ID: PWO2B2725

Report #: W\WILSON_PWO\1851AUT12\1851AUT12TestReport.doc

Requirements: Emissions must be $43 + 10\log(P_o)$ dB below the mean power output of the transmitter:

$$824 - 849 \text{ MHz: } 43 + 10\log(1.00) = 43 \text{ dBc}$$

$$869 - 894 \text{ MHz: } 43 + 10\log(0.001) = 13 \text{ dBc}$$

Test Result: The DUT meets the requirements

Test Data Table 45 – Conducted Emissions – CDMA 800 - Uplink

Emission Frequency MHz	dB Below Carrier (dBc)	Emission Frequency MHz	dB Below Carrier (dBc)	Emission Frequency MHz	dB Below Carrier (dBc)
825.25		836.50		847.75	
1650.50	73.5	1673.00	73.1	1695.50	72.1
2475.75	78.7	2509.50	78.0	2543.25	78.5
3301.00	70.0	3346.00	72.3	3391.00	75.3
4126.25	78.4	4182.50	78.9	4238.75	78.7
4951.50	NF	5019.00	NF	5086.50	NF
5776.75	NF	5855.50	NF	5934.25	NF
6602.00	NF	6692.00	NF	6782.00	NF
7427.25	NF	7528.50	NF	7629.75	NF
8252.50	NF	8365.00	NF	8477.50	NF

Test Data Table 46 – Conducted Emissions – CDMA 800 – Downlink

Emission Frequency MHz	dB Below Carrier (dBc)	Emission Frequency MHz	dB Below Carrier (dBc)	Emission Frequency MHz	dB Below Carrier (dBc)
870.25		881.50		892.75	
1740.50	60.2	1763.00	60.7	1785.50	58.2
2610.75	59.5	2644.50	60.6	2678.25	59.3
3481.00	60.2	3526.00	61.2	3571.00	59.4
4351.25	59.8	4407.50	60.5	4463.75	59.7
5221.50	58.5	5289.00	59.7	5356.50	56.9
6091.75	NF	6170.50	NF	6249.25	NF
6962.00	NF	7052.00	NF	7142.00	NF
7832.25	NF	7933.50	NF	8034.75	NF
8702.50	NF	8815.00	NF	8927.50	NF

Test Data Table 47 – Conducted Emissions – GSM 800 - Uplink

Emission Frequency MHz	dB Below Carrier (dBc)	Emission Frequency MHz	dB Below Carrier (dBc)	Emission Frequency MHz	dB Below Carrier (dBc)
824.20		836.50		848.80	
1648.40	79.3	1673.00	77.5	1697.60	76.2
2472.60	83.8	2509.50	84.5	2546.40	84.2
3296.80	74.9	3346.00	75.9	3395.20	80.3
4121.00	82.3	4182.50	83.5	4244.00	83.1
4945.20	85.4	5019.00	NF	5092.80	NF
5769.40	NF	5855.50	NF	5941.60	NF
6593.60	NF	6692.00	NF	6790.40	NF
7417.80	NF	7528.50	NF	7639.20	NF
8242.00	NF	8365.00	NF	8488.00	NF

Test Data Table 48 – Conducted Emissions – GSM 800 - Downlink

Emission Frequency MHz	dB Below Carrier (dBc)	Emission Frequency MHz	dB Below Carrier (dBc)	Emission Frequency MHz	dB Below Carrier (dBc)
869.20		881.50		893.80	
1738.40	59.0	1763.00	60.2	1787.60	58.6
2607.60	59.8	2644.50	60.3	2681.40	59.1
3476.80	60.7	3526.00	60.5	3575.20	59.3
4346.00	59.5	4407.50	61.4	4469.00	59.2
5215.20	60.1	5289.00	59.7	5362.80	56.8
6084.40	NF	6170.50	NF	6256.60	NF
6953.60	NF	7052.00	NF	7150.40	NF
7822.80	NF	7933.50	NF	8044.20	NF
8692.00	NF	8815.00	NF	8938.00	NF

FIELD STRENGTH OF SPURIOUS EMISSIONS

Rule Parts No.: Pt 2.1053

Requirements: Emissions must be 43+10log(Po) dB below the mean power output of the amplifier:

$$43 + 10\log(1.000) = 43.0 \text{ dB}$$

$$43 + 10\log(0.001) = 13.0 \text{ dB}$$

Test Result: The test data indicates the DUT meets the requirements

Test Data Table 49 – Radiated Emissions – CW (1900 MHz) – Uplink /Downlink

Emission Frequency MHz	Ant. Polarity	dB Below Carrier (dBc)	Emission Frequency MHz	Ant. Polarity	dB Below Carrier (dBc)
1880.00	0	0	1960.00	0	0
3760.00	V	78.8	3920.00	V	48.1
5640.00	V	81.7	5880.00	V	49.6
7520.00	V	82.9	7840.00	V	49.9
9400.00	V	79.7	9800.00	V	40.0
11280.00	V	77.7	11760.00	V	40.8
13160.00	H/V	NF	13720.00	H/V	NF
15040.00	H/V	NF	15680.00	H/V	NF
16920.00	H/V	NF	17640.00	H/V	NF
18800.00	H/V	NF	19600.00	H/V	NF

Notes: *No other emissions were found up to the 10th harmonics - NOISE FLOOR

[Continued]

Test Data Table 50 – Radiated Emissions – CW (1700 MHz) – Uplink /Downlink

Emission Frequency MHz	Ant. Polarity	dB Below Carrier (dBc)	Emission Frequency MHz	Ant. Polarity	dB Below Carrier (dBc)
1732.50	0	0	2132.50	0	0
3465.00	V	64.8	4265.00	V	51.2
5197.50	V	80.5	6397.50	V	49.5
6930.00	V	68.6	8530.00	V	46.9
8662.50	V	65.2	10662.50	V	44.5
10395.00	V	67.5	12795.00	H/V	NF
12127.50	H/V	NF	14927.50	H/V	NF
13860.00	H/V	NF	17060.00	H/V	NF
15592.50	H/V	NF	19192.50	H/V	NF
17325.00	H/V	NF	21325.00	H/V	NF

Notes: *No other emissions were found up to the 10th harmonics - NOISE FLOOR

Test Data Table 51 – Radiated Emissions – CW (800 MHz) – Uplink /Downlink

Emission Frequency MHz	Ant. Polarity	dB Below Carrier (dBc)	Emission Frequency MHz	Ant. Polarity	dB Below Carrier (dBc)
836.50	0	0	881.50	0	0
1673.00	V	73.7	1763.00	V	57.6
2509.50	V	65.5	2644.50	V	53.6
3346.00	V	61.2	3526.00	V	50.8
4182.50	V	72.1	4407.50	V	50.8
5019.00	V	75.2	5289.00	V	47.9
5855.50	V	77.2	6170.50	V	49.8
6692.00	V	79.7	7052.00	V	49.7
7528.50	V	81.1	7933.50	V	49.4
8365.00	V	79.3	8815.00	V	47.2

Notes: *No other emissions were found up to the 10th harmonics - NOISE FLOOR

OUT OF BAND REJECTION: FREQUENCY RESPONSE

1900 MHz

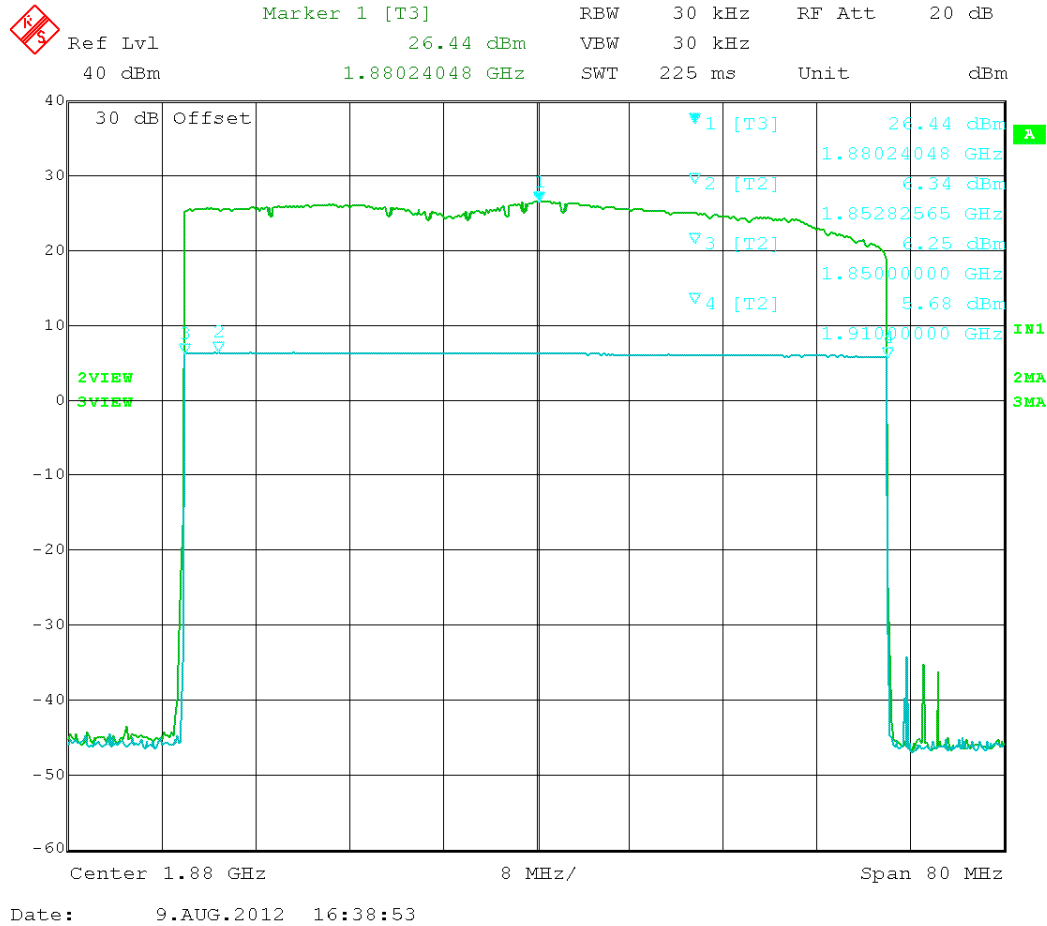

Figure 85. Frequency response (1850 – 1910) MHz band

Input	6.34
Output	26.44
Pass Band Gain	20.10

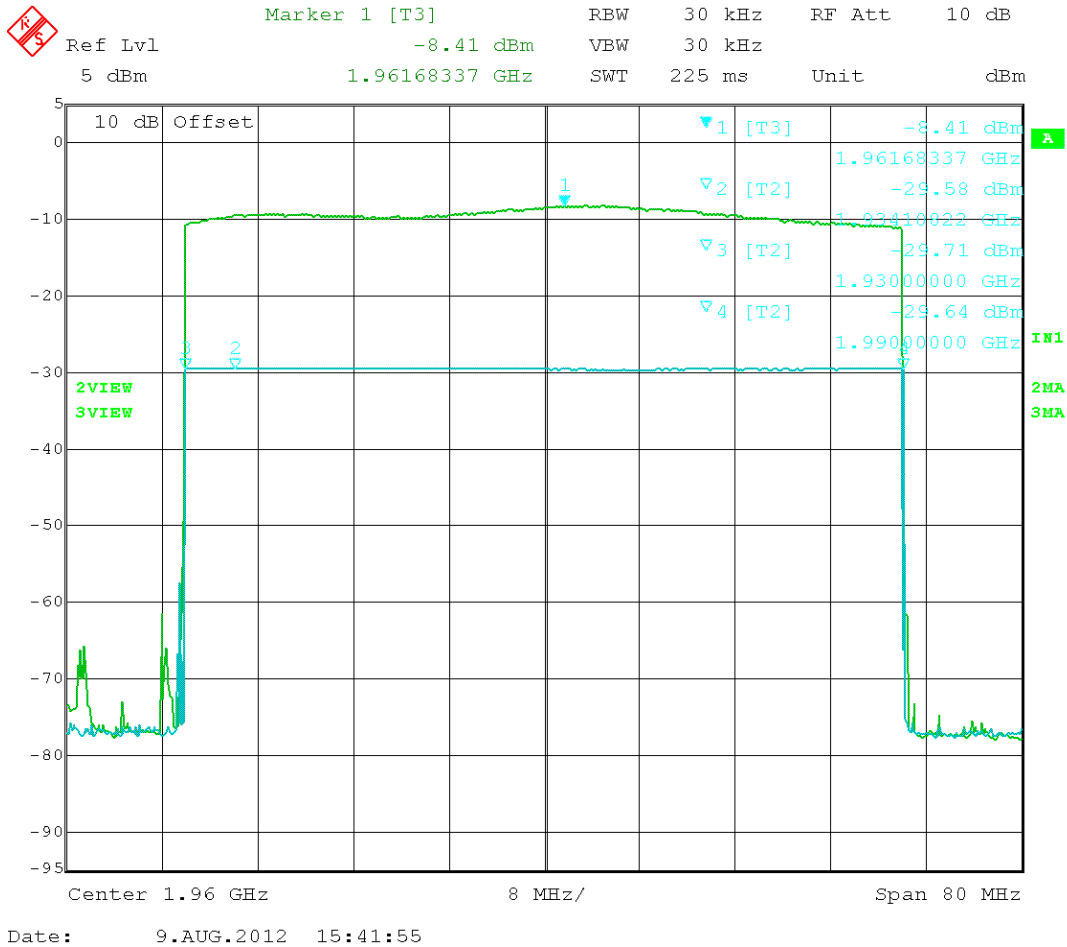

Figure 86. Frequency response (1930 – 1990) MHz band

Input	-29.58
Output	-8.41
Pass Band Gain	21.17

1700 MHz



Marker 1 [T3] RBW 30 kHz RF Att 20 dB
 Ref Lvl 25.32 dBm VBW 30 kHz
 40 dBm 1.71139780 GHz SWT 170 ms Unit dBm

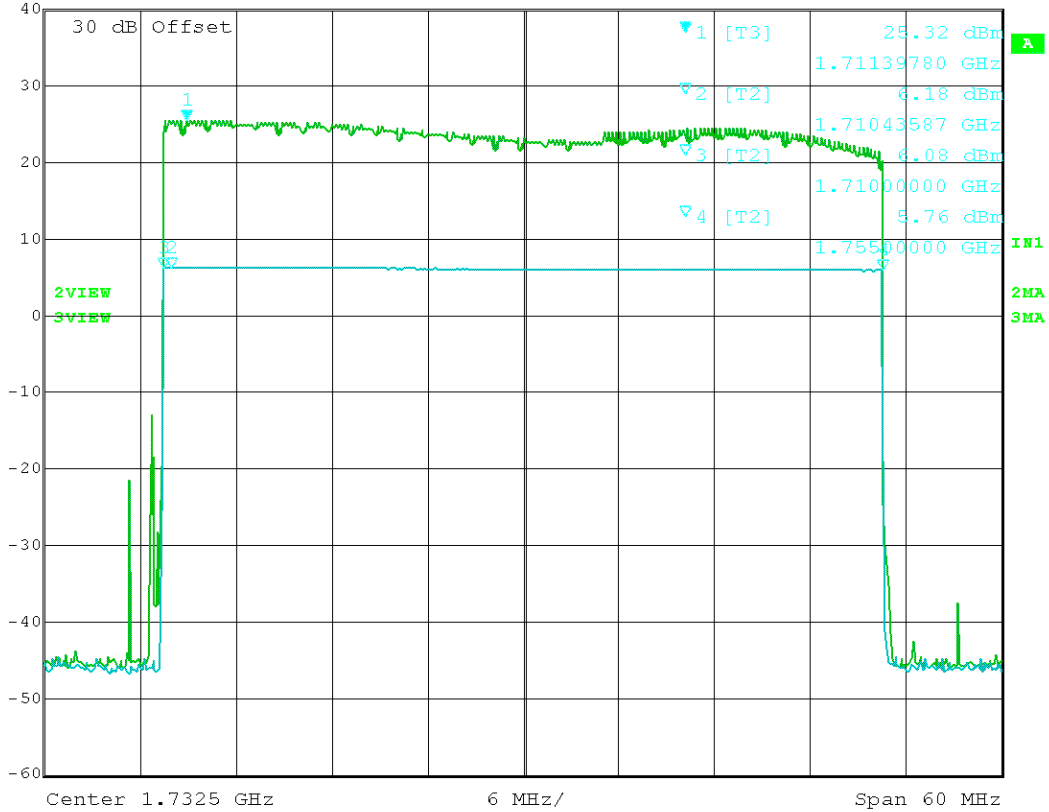

Date: 9.AUG.2012 16:14:21

Figure 87. Frequency response (1710 – 1755) MHz band

Input	6.18
Output	25.32
Pass Band Gain	19.14

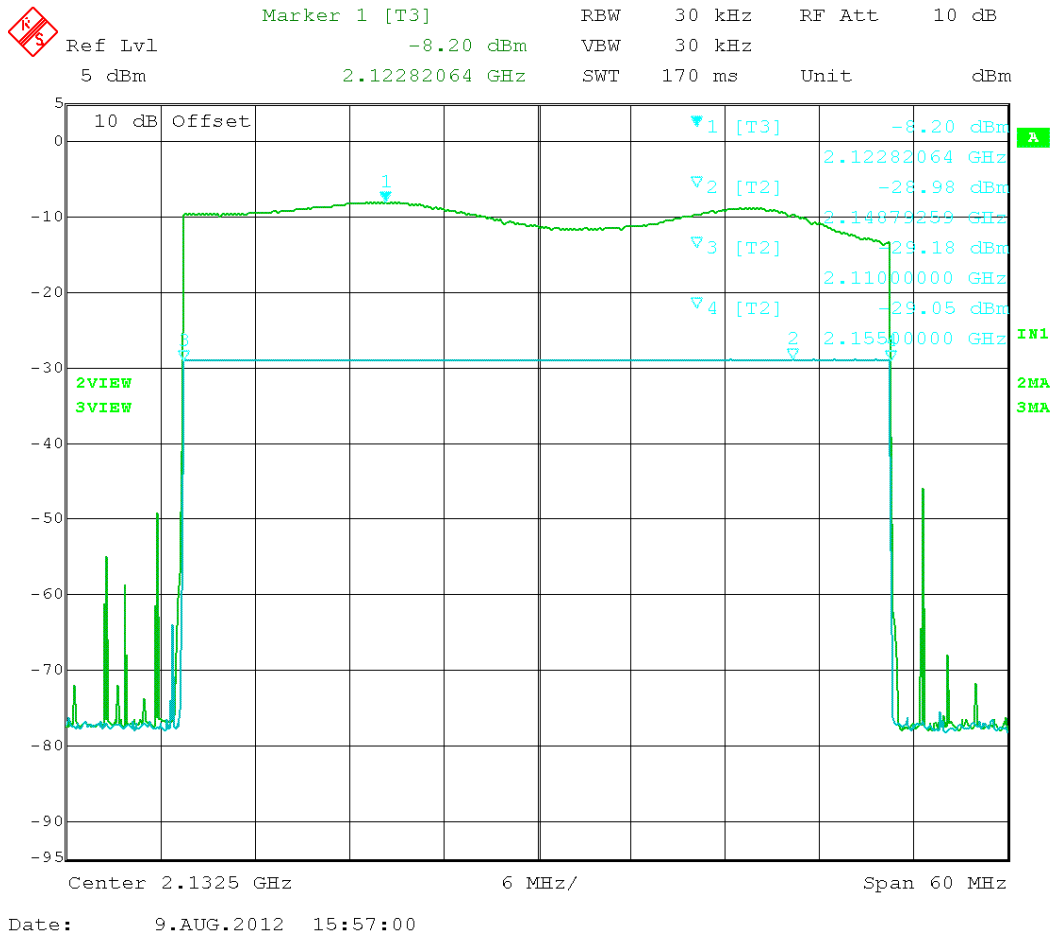

Figure 88. Frequency response (2110 – 2155) MHz band

Input	-28.98
Output	-8.2
Pass Band Gain	20.78

800 MHz

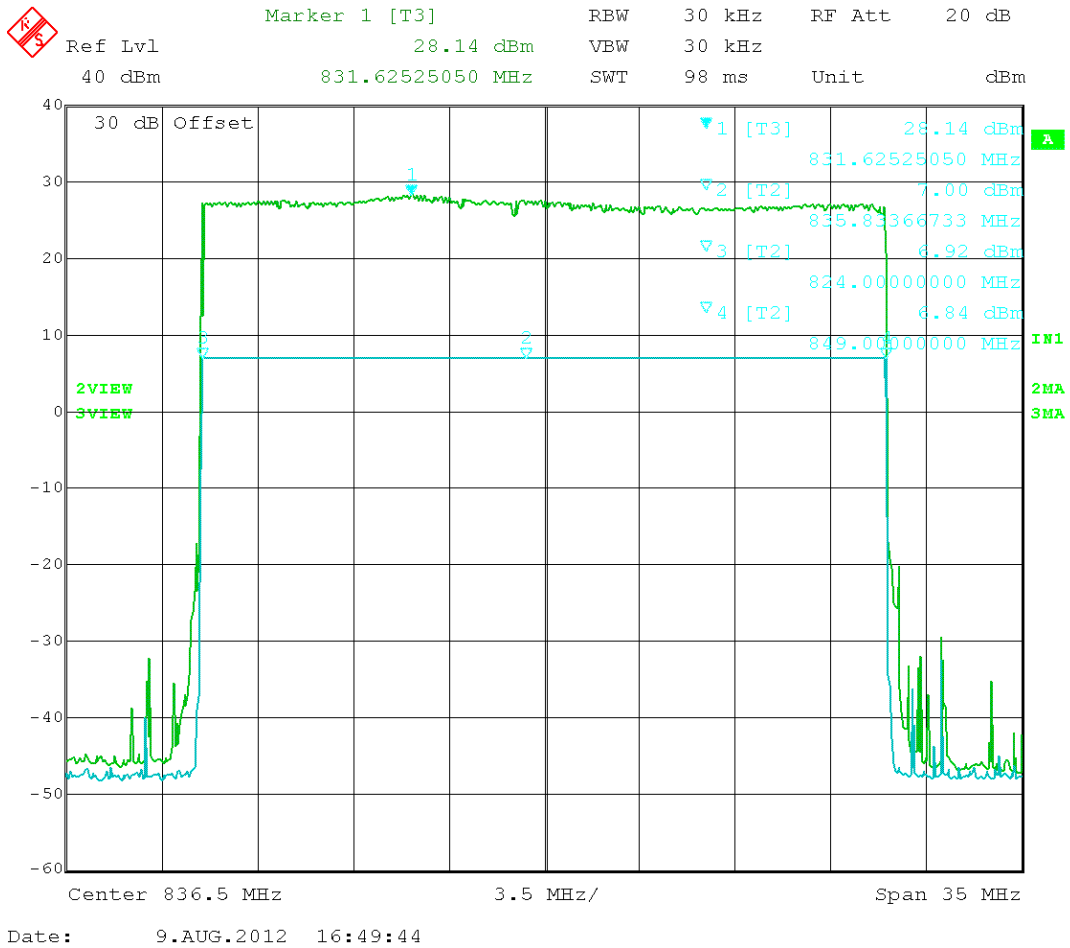

Figure 89. Frequency response (824 – 849) MHz band

Input	7.0
Output	28.14
Pass Band Gain	21.14

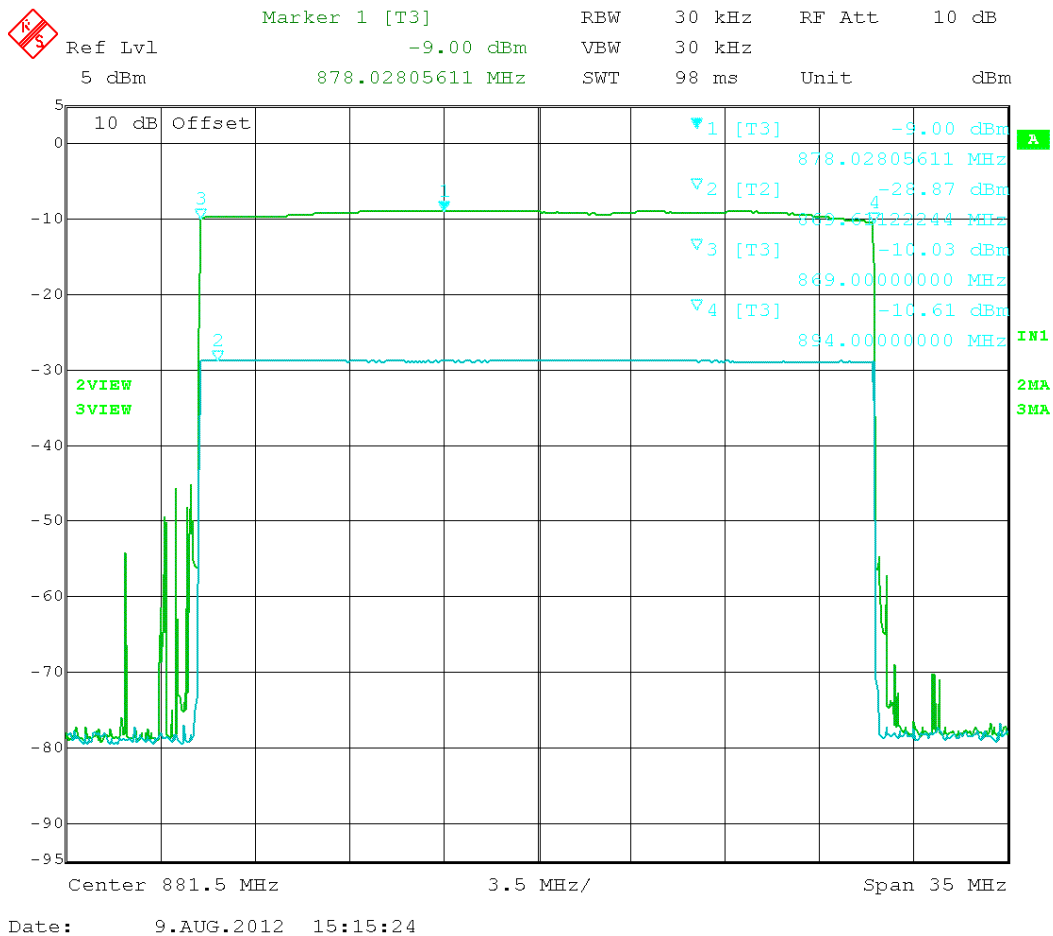

Figure 90. Frequency response (869 – 894) MHz band

Input	-28.87
Output	-9
Pass Band Gain	19.87