



849 NW STATE ROAD 45
NEWBERRY, FL 32669 USA
PH: 888.472.2424 OR 352.472.5500
FAX: 352.472.2030
EMAIL: TEI@TIMCOENGR.COM
[HTTP://WWW.TIMCOENGR.COM](http://WWW.TIMCOENGR.COM)

FCC PART 22H AND PART 24E TEST REPORT

Applicant	WILSON ELECTRONICS, INC.
Address	3301 E. DESERET DRIVE ST. GEORGE UTAH 84790 USA
FCC ID	PWO275370
Model Number	275370
Product Description	WIRELESS, TRI-BAND BI-DIRECTIONAL AMPLIFIER
Date Sample Received	4/27/2012
Date Tested	6/4/2012
Tested By	Nam Nguyen
Approved By	Mario de Aranzeta
Report No.	1095AUT12TestReport.doc
Test Results	<input checked="" type="checkbox"/> PASS <input type="checkbox"/> FAIL

THE ATTACHED REPORT SHALL NOT BE REPRODUCED EXCEPT IN FULL
WITHOUT THE WRITTEN APPROVAL OF TIMCO ENGINEERING, INC.



Test Certificate #0955-01



TABLE OF CONTENTS

ATTESTATION STATEMENT..... 3
REPORT SUMMARY 4
TEST ENVIRONMENT 4
TEST SETUP 4
DEVICE UNDER TEST INFORMATION 5
EQUIPMENT LIST 6
TEST PROCEDURE..... 7
RF POWER OUTPUT 10
Test Data Table 1 - Output Power - CDMA 1900 - Uplink/Downlink..... 10
Test Data Table 2 - Output Power - HSPA 1900 - Uplink/Downlink 10
Test Data Table 3 - Output Power - LTE 1900 - Uplink/Downlink..... 10
Test Data Table 4 - Output Power - GSM 1900 - Uplink/Downlink 10
Test Data Table 5 - Output Power - EDGE 1900 - Uplink/Downlink 11
Test Data Table 6 - Output Power - CDMA 800 - Uplink/Downlink..... 11
Test Data Table 7 - Output Power - HSPA 800 - Uplink/Downlink 11
Test Data Table 8 - Output Power - LTE 800 - Uplink/Downlink..... 11
Test Data Table 9 - Output Power - GSM 800 - Uplink/Downlink 11
Test Data Table 10 - Output Power - EDGE 800 - Uplink/Downlink 12
Test Data Table 11 - Output Power - LTE 700 - Uplink/Downlink..... 12
INPUT/OUTPUT MODULATED AMPLITUDE COMPARISON AND BAND-EDGES COMPLIANCE
..... 13
Test Data Table 12 - CDMA 1900 - Uplink/Downlink..... 14
Test Data Table 13 - HSPA 1900 - Uplink/Downlink 18
Test Data Table 14 - LTE 1900 - Uplink/Downlink..... 22
Test Data Table 15 -GSM 1900 - Uplink/Downlink 26
Test Data Table 16 - EDGE 1900 - Uplink/Downlink 30
Test Data Table 17 - CDMA 800 - Uplink/Downlink..... 34
Test Data Table 18 - HSPA 800 - Uplink/Downlink..... 38
Test Data Table 19 - LTE 800 - Uplink/Downlink..... 42
Test Data Table 20 - GSM 800 - Uplink/Downlink 46
Test Data Table 21 - EDGE 800 - Uplink/Downlink 50
Test Data Table 22 - LTE 700 - Uplink/Downlink..... 54
INTERMODULATION PRODUCT SPURIOUS EMISSIONS..... 58
SPURIOUS EMISSIONS AT ANTENNA TERMINALS 66
Test Data Table 23 - Conducted Emissions - CDMA 1900 - Uplink 66
Test Data Table 24 - Conducted Emissions - CDMA 1900 - Downlink..... 66
Test Data Table 25 - Conducted Emissions - GSM 1900 - Uplink 67
Test Data Table 26 - Conducted Emissions - GSM 1900 - Downlink..... 67
Test Data Table 27 - Conducted Emissions - CDMA 800 - Uplink..... 67
Test Data Table 28 - Conducted Emissions - CDMA 800 - Downlink 68
Test Data Table 29 - Conducted Emissions - GSM 800 - Uplink..... 68
Test Data Table 30 - Conducted Emissions - GSM 800 - Downlink..... 68
FIELD STRENGTH OF SPURIOUS EMISSIONS 69
Test Data Table 31 - Radiated Emissions - CW (1900 MHz) - Uplink /Downlink..... 69
Test Data Table 32 - Radiated Emissions - CW (800 MHz) - Uplink /Downlink 70
OUT OF BAND REJECTION: FREQUENCY RESPONSE 71

Applicant: WILSON ELECTRONICS, INC.
FCC ID: PWO275370
Report: W\WILSON_PWO\1095AUT12\1095AUT12TestReport.doc

ATTESTATION STATEMENT

Summary

The device under test does:

- fulfill the general approval requirements as identified in this test report
- not fulfill the general approval requirements as identified in this test report

This equipment has been tested in accordance with the standards identified in this test report. To the best of my knowledge and belief, these tests were performed using the measurement procedures described in this report. All instrumentation and accessories used to test products for compliance to the indicated standards are calibrated regularly in accordance with ISO 17025:2005 requirements.



Certificate # 0955-01

I attest that the necessary measurements were made, under my supervision, at TIMCO ENGINEERING, INC. located at 849 N.W. State Road 45, Newberry, Florida 32669.

Authorized Signatory Name: Mario de Aranzeta



Signature:

Function: Engineer/ Lab Supervisor

Date: June/15/2012

Applicant: WILSON ELECTRONICS, INC.
FCC ID: PWO275370
Report: W\WILSON_PWO\1095AUT12\1095AUT12TestReport.doc

REPORT SUMMARY

Disclaimer	The test results relate only to the items tested.
Report Purpose	To demonstrate the DUT comply with FCC Part 22H and Pt 24 and Industry Canada RS-131 requirements for a dual band signal amplifier.
Applicable Rule Part(s)	Pt 22, Pt 24, Pt 15.109
Test Procedure(s)	ANSI/TIA-603-C: 2004

TEST ENVIRONMENT

Test Facilities	All required tests were performed by Timco Engineering Inc. that is located at 849 NW State Road 45 Newberry, FL 32669.
Test Conditions	Temperature: 26°C Relative Humidity: 50%

TEST SETUP

Deviation to the rules	There was no deviation from the test standards.
Modification to the DUT	No modification was made to the DUT.
Test Exercise (e.g. software description, test signal, etc.)	The DUT was placed in continuous transmit mode of operation.

DEVICE UNDER TEST INFORMATION

Manufactured by	WILSON ELECTRONICS, INC.		
DUT Description	WIRELESS, TRI-BAND BI-DIRECTIONAL AMPLIFIER		
FCC ID	PWO275370		
Model Name	275370		
Operating Frequency	Uplink 698 – 716 MHz Downlink 728 – 746 MHz Uplink 824 – 849 MHz Downlink 869 – 894 MHz Uplink 1850 – 1910 MHz Downlink 1930 – 1990 MHz		
Emission Designators	F9W (CDMA & HSPA), GXW (GSM), G7W (EDGE), G7D (LTE)		
Modulation(s)	CDMA, HSPA, LTE, GSM, EDGE, HSPA, EVDO		
User Power Range & Control	There are NO user power controls		
Test Item	Pre-Production		
DC Voltage and Current into final amplifier	Band MHz	Volts	Amps
	698 – 716	4.05	0.5
	728 – 746	4.05	0.5
	824 – 849	4.05	0.5
	869 – 894	4.05	0.5
	1850 – 1910	4.05	0.5
	1930 – 1990	4.05	0.5
Type of Equipment	Fixed		

EQUIPMENT LIST

Device	Manufacturer	Model	Serial Number	Cal/Char Date	Due Date
3-Meter Semi-Anechoic Chamber	Panashield	N/A	N/A	Listed 12/31/11	12/31/13
AC Voltmeter	HP	400FL	2213A14499	CAL 6/12/11	6/12/13
Antenna: Active Loop	ETS-Lindgren	6502	00062529	CAL 9/23/10	9/23/12
Frequency Counter	HP	5385A	2730A03025	CAL 8/17/11	8/17/13
Hygro-Thermometer	Extech	445703	0602	CAL 6/15/11	6/15/13
Modulation Analyzer	HP	8901A	3435A06868	CAL 7/18/11	7/18/13
Digital Multimeter	Fluke	FLUKE-77	35053830	CAL 9/9/11	9/9/13
Power Meter	Boonton Electronics	4531	11793	CAL 11/12/2010	11/12/2012
EMI Receiver	Rohde & Schwarz	ESIB40	100274	CAL 3/16/2012	3/16/2014
Analyzer Tan Tower Preamplifier	HP	8449B-H02	3008A00372	CAL 10/28/11	10/28/13
Analyzer Tan Tower Quasi-Peak Adapter	HP	85650A	3303A01690	CAL 10/28/11	10/28/13
Analyzer Tan Tower RF Preselector	HP	85685A	3221A01400	CAL 10/28/11	10/28/13
Analyzer Tan Tower Spectrum Analyzer	HP	8566B Opt 462	3138A07786 3144A20661	CAL 10/28/11	10/28/13
Antenna	ETS	3117	35923	12/7/2011	12/7/2013
Antenna	Electro metrics	LPA-25	1122	5/04/2011	5/04/2013
Antenna	Electro metrics	BIA-25	1096	5/04/2011	5/04/2013

Applicant: WILSON ELECTRONICS, INC.
 FCC ID: PWO275370
 Report: W\WILSON_PWO\1095AUT12\1095AUT12TestReport.doc

TEST PROCEDURE

RF Power Output

RF power is measured by connecting a 50-ohm, resistive wattmeter to the RF output connector. With a nominal voltage and the amplifier properly adjusted the RF output measures.

RF Output Power Test Setup Diagram

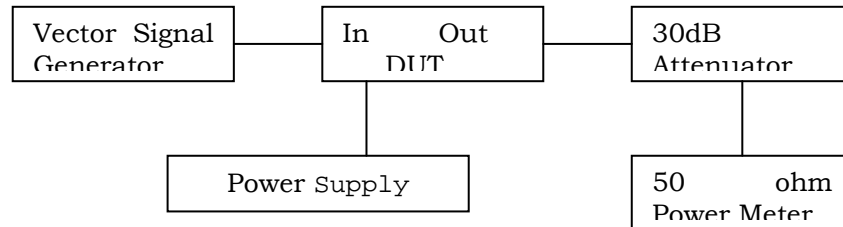

Input/Output Modulated Amplitude Comparison And Band-Edges Compliance

On the following plot, the reference level was calibrated using a resolution bandwidth wider than the emission bandwidth. First the gain was measured for the maximum output power. Then for each frequency and type of modulation, an attenuation equals to the gain of the amplifier was added on the measurement side of the amplifier, as to overlay the input versus output modulated envelope.

Test Setup Diagram

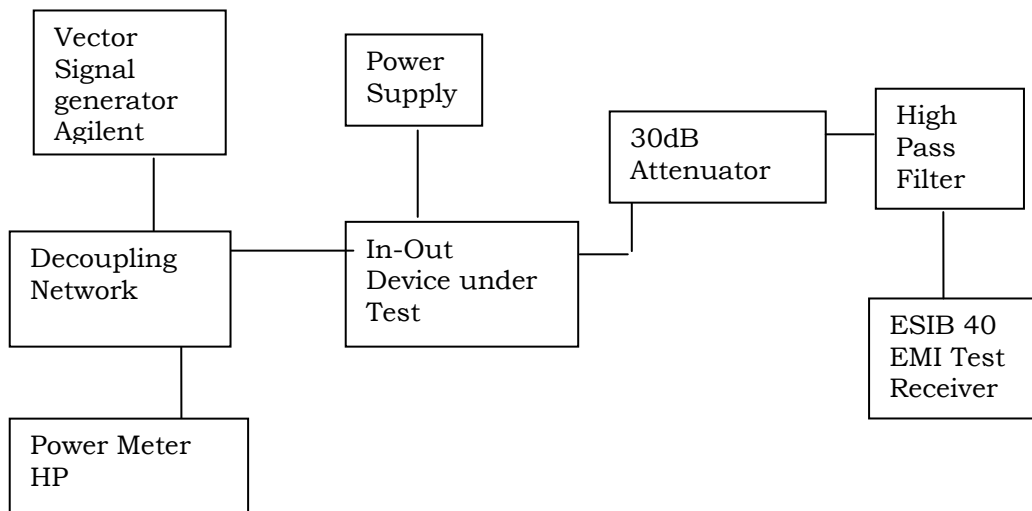

[Continued]

Intermodulation Product Spurious Emissions

The procedure used was ANSI/TIA-603-C: 2004. The spectrum was scanned from 9kHz to at least the tenth harmonic of the fundamental using a HP 8566B spectrum analyzer.

The modulation type was tested using the two-tone / three tone test method. The input power to the amplifier was set at maximum drive level by combining the two tones. The two tones were chosen in such a way (1) the third order intermodulation product frequencies are located within the pass band of the DUT and (2) they produce the worst-case emissions out of band.

Setup Diagram

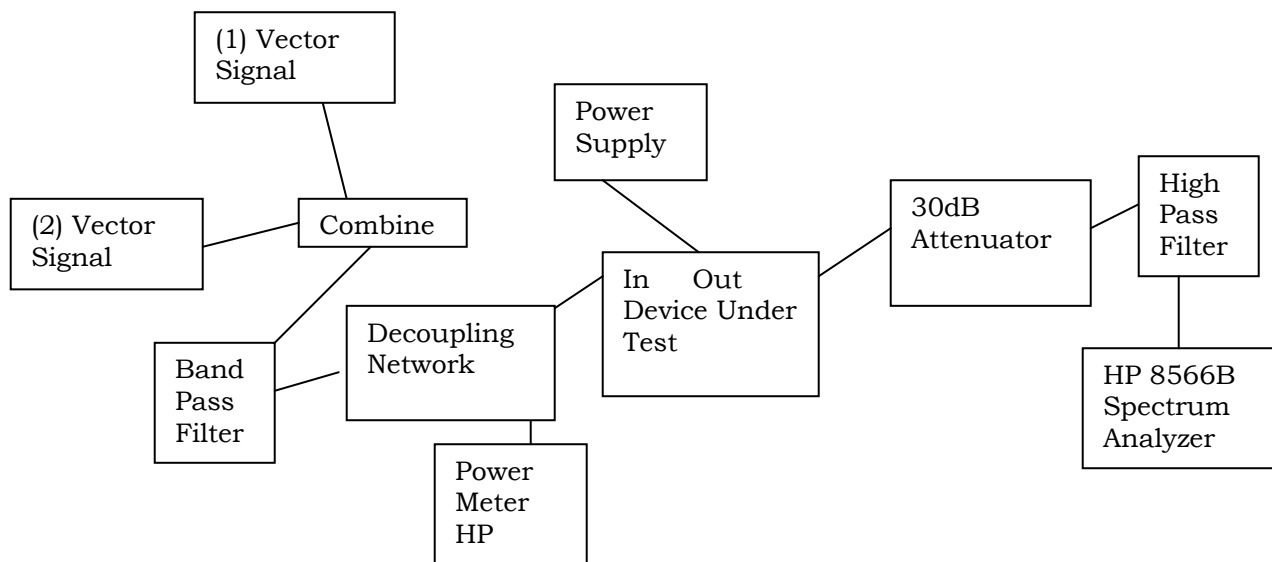

Spurious Emissions at Antenna Terminals

The procedure used was ANSI/TIA-603-C: 2004. The spectrum was scanned from 9kHz to at least the tenth harmonic of the fundamental using a HP model 8566B spectrum analyzer.

Data on the following page shows the level of conducted spurious responses. For analog modulation, the carrier was modulated 100% using a 2500 Hz tone. For digital modulation, the carrier is modulated to its maximum extent. The spectrum was scanned from 9 kHz to at least the 10th harmonic of the fundamental. The measurements were made in accordance with standard ANSI/TIA-603-C: 2004. The maximum input power was set for each test.

[Continued]

Conducted Spurious Emissions Test Setup Diagram

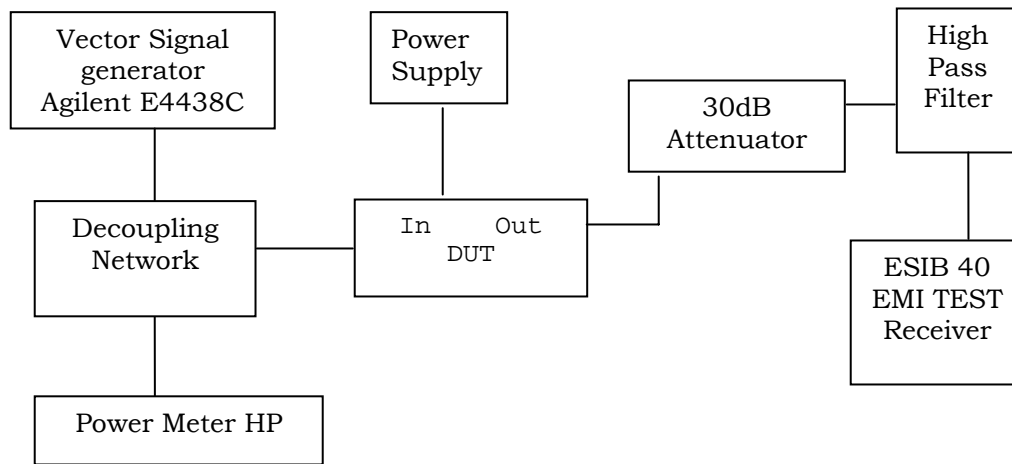

Radiated Spurious Emissions

The spectrum was scanned from 30 MHz to at least the tenth harmonic of the fundamental. The CW signal was used to perform this test. This test was conducted per ANSI/TIA-603-C: 2004 using the substitution method.

Radiated Spurious Emissions Test Setup Diagram

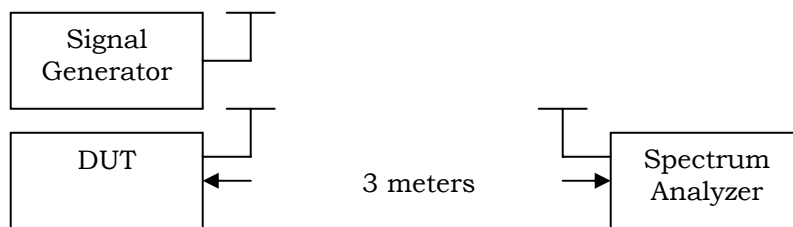

Equipment placed 80 cm above ground on a rotating table platform.

RF POWER OUTPUT

Rule Part(s) No.: Pt 2.1046(a)

Requirements: Pt 2.1046(a)

Test Result: As the following table indicates. Notes: the maximum power output value was obtained with CDMA modulation at 1880MHz and 847.75MHz.

Test Data Table 1 – Output Power – CDMA 1900 – Uplink/Downlink

Tuned Frequency (MHz)	Power Input (dBm)	Power Output (dBm)	Power Output (mW)	Tuned Frequency (MHz)	Power Input (dBm)	Power Output (dBm)	Power Output (mW)
1851.25	-42.0	28.3	676	1931.25	-46.0	24.3	269.2
1880.00	-43.0	29.3	851	1960.00	-47.0	25.2	331.1
1908.75	-41.0	25.9	389	1988.75	-48.0	24.9	309

Test Data Table 2 – Output Power – HSPA 1900 – Uplink/Downlink

Tuned Frequency (MHz)	Power Input (dBm)	Power Output (dBm)	Power Output (mW)	Tuned Frequency (MHz)	Power Input (dBm)	Power Output (dBm)	Power Output (mW)
1852.50	-44.0	27.2	525	1932.50	-47.0	24.7	295.1
1880.00	-44.0	28.3	676	1960.00	-48.0	24.4	275.4
1907.50	-41.0	26.0	398	1987.50	-49.0	24.8	302

Test Data Table 3 – Output Power – LTE 1900 – Uplink/Downlink

Tuned Frequency (MHz)	Power Input (dBm)	Power Output (dBm)	Power Output (mW)	Tuned Frequency (MHz)	Power Input (dBm)	Power Output (dBm)	Power Output (mW)
1855.00	-44.0	28.1	646	1935.00	-48.0	24.9	309
1880.00	-45.0	28.2	661	1960.00	-48.0	24.7	295.1
1905.00	-43.0	25.9	389	1985.00	-51.0	24.9	309

Test Data Table 4 – Output Power – GSM 1900 – Uplink/Downlink

Tuned Frequency (MHz)	Power Input (dBm)	Power Output (dBm)	Power Output (mW)	Tuned Frequency (MHz)	Power Input (dBm)	Power Output (dBm)	Power Output (mW)
1850.20	-42.0	27.7	589	1930.20	-44.0	24.1	257
1880.00	-44.0	28.1	646	1960.00	-47.0	24.4	275.4
1909.80	-40.0	26.1	407	1989.80	-44.0	24.1	257

[Continued]

Applicant: WILSON ELECTRONICS, INC.
 FCC ID: PWO275370
 Report: W\WILSON_PWO\1095AUT12\1095AUT12TestReport.doc

Test Data Table 5 – Output Power – EDGE 1900 – Uplink/Downlink

Tuned Frequency (MHz)	Power Input (dBm)	Power Output (dBm)	Power Output (mW)
1850.20	-42.0	27.6	575
1880.00	-44.0	27.9	617
1909.80	-40.0	26.0	398

Tuned Frequency (MHz)	Power Input (dBm)	Power Output (dBm)	Power Output (mW)
1930.20	-46.0	23.7	234.4
1960.00	-47.0	24.5	281.8
1989.80	-47.0	24.6	288.4

Test Data Table 6 – Output Power – CDMA 800 – Uplink/Downlink

Tuned Frequency (MHz)	Power Input (dBm)	Power Output (dBm)	Power Output (mW)
825.25	-46.0	27.4	550
836.50	-48.0	27.9	617
847.75	-46.0	28.3	676

Tuned Frequency (MHz)	Power Input (dBm)	Power Output (dBm)	Power Output (mW)
870.25	-48.0	24.8	302
881.50	-49.0	25.2	331.1
892.75	-48.0	24.3	269.2

Test Data Table 7 – Output Power – HSPA 800 – Uplink/Downlink

Tuned Frequency (MHz)	Power Input (dBm)	Power Output (dBm)	Power Output (mW)
826.50	-48.0	25.7	372
836.50	-49.0	26.5	447
846.50	-48.0	26.8	479

Tuned Frequency (MHz)	Power Input (dBm)	Power Output (dBm)	Power Output (mW)
871.50	-49.0	25.2	331.1
881.50	-49.0	25.3	338.8
891.50	-49.0	24.2	263

Test Data Table 8 – Output Power – LTE 800 – Uplink/Downlink

Tuned Frequency (MHz)	Power Input (dBm)	Power Output (dBm)	Power Output (mW)
829.00	-48.0	25.6	363
836.50	-49.0	26.4	437
844.00	-49.0	26.6	457

Tuned Frequency (MHz)	Power Input (dBm)	Power Output (dBm)	Power Output (mW)
874.00	-50.0	24.7	295.1
881.50	-50.0	24.5	281.8
889.00	-49.0	24.6	288.4

Test Data Table 9 – Output Power – GSM 800 – Uplink/Downlink

Tuned Frequency (MHz)	Power Input (dBm)	Power Output (dBm)	Power Output (mW)
824.20	-47.0	26.1	407
836.50	-48.0	27.3	537
848.80	-47.0	26.9	490

Tuned Frequency (MHz)	Power Input (dBm)	Power Output (dBm)	Power Output (mW)
869.20	-48.0	24.5	281.8
881.50	-49.0	24.9	309
893.80	-47.0	24.4	275.4

[Continued]

Test Data Table 10 – Output Power – EDGE 800 – Uplink/Downlink

Tuned Frequency (MHz)	Power Input (dBm)	Power Output (dBm)	Power Output (mW)
824.20	-46.0	26.7	468
836.50	-48.0	27.1	513
848.80	-47.0	26.8	479

Tuned Frequency (MHz)	Power Input (dBm)	Power Output (dBm)	Power Output (mW)
869.20	-48.0	24.5	281.8
881.50	-49.0	24.7	295.1
893.80	-47.0	23.9	245.5

Test Data Table 11 – Output Power – LTE 700 – Uplink/Downlink

Tuned Frequency (MHz)	Power Input (dBm)	Power Output (dBm)	Power Output (mW)
703.00	-46.0	26.4	437
707.00	-46.0	26.8	479
711.00	-46.0	26.2	417

Tuned Frequency (MHz)	Power Input (dBm)	Power Output (dBm)	Power Output (mW)
733.00	-50.0	24.9	309
737.00	-51.0	24.5	282
741.00	-50.0	24.9	309



INPUT/OUTPUT MODULATED AMPLITUDE COMPARISON AND BAND-EDGES COMPLIANCE

Rule Parts No.: Pt 2.1049, Pt 2.1051, 22H, 24E

Requirements: The power of any emission outside of the authorized operating frequency ranges must be attenuated below the transmitting power (P) by a factor of at least $43 + 10 \log(P)$ dB.

Test Data: The DUT appears to meet the requirements.

Applicant: WILSON ELECTRONICS, INC.
FCC ID: PWO275370
Report: W\WILSON_PWO\1095AUT12\1095AUT12TestReport.doc

Bandedge compliance: Measurements were performed in accordance with Part 24.238

The Reference level on the following plots was calibrated using a 3MHz RBW=VBW.

Compensating for RBW (1%) using $10 \log(12.5/3) = 6.2 \text{ dB}$ we get the following amplitudes at the bandedge:

Test Data Table 12 – CDMA 1900 – Uplink/Downlink				
Channel (MHz)	Bandedge Frequency (MHz)	Amplitude bandedge (dBm)	Limit (dBm)	Margin (dB)
1851.25	1849.91	-24.72	-13	11.72
1908.75	1910.14	-25.98	-13	12.98
1931.25	1929.96	-26.06	-13	13.06
1988.75	1990.04	-26.65	-13	13.65

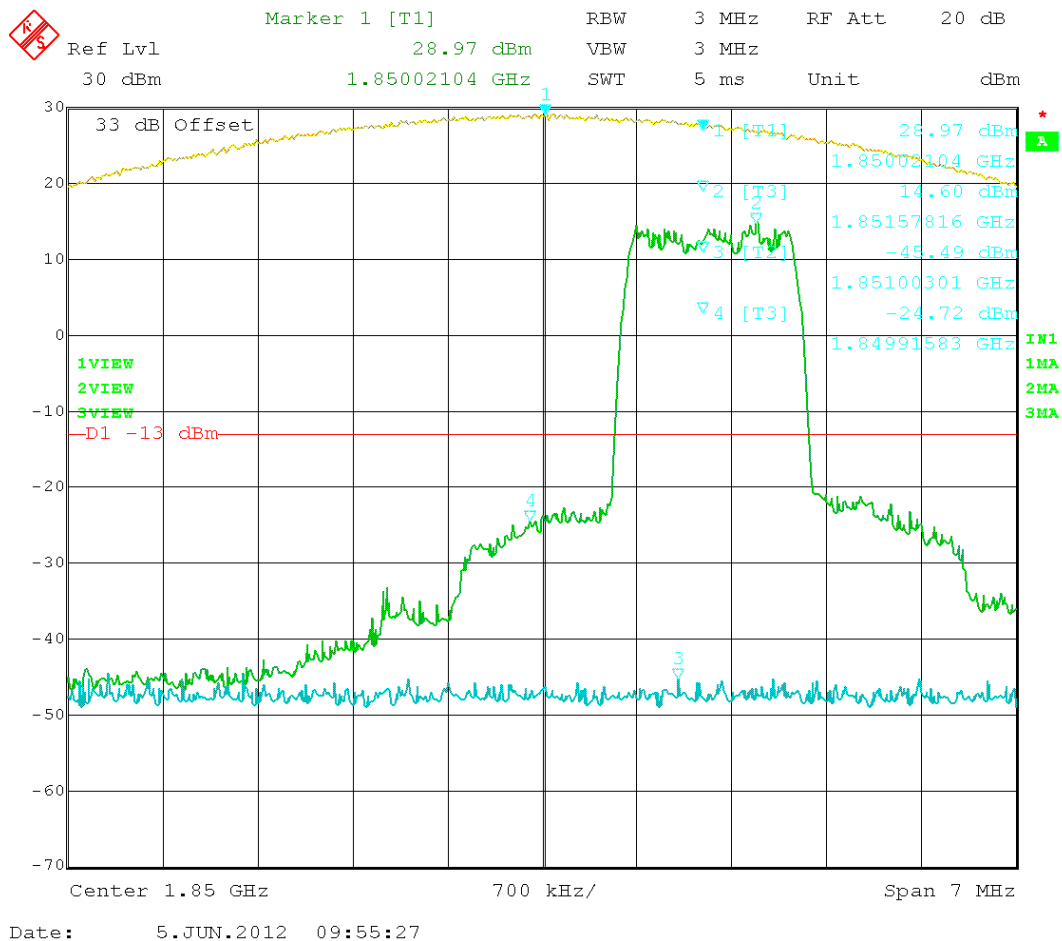

Figure 1: CDMA – In vs. Out 1851.25MHz

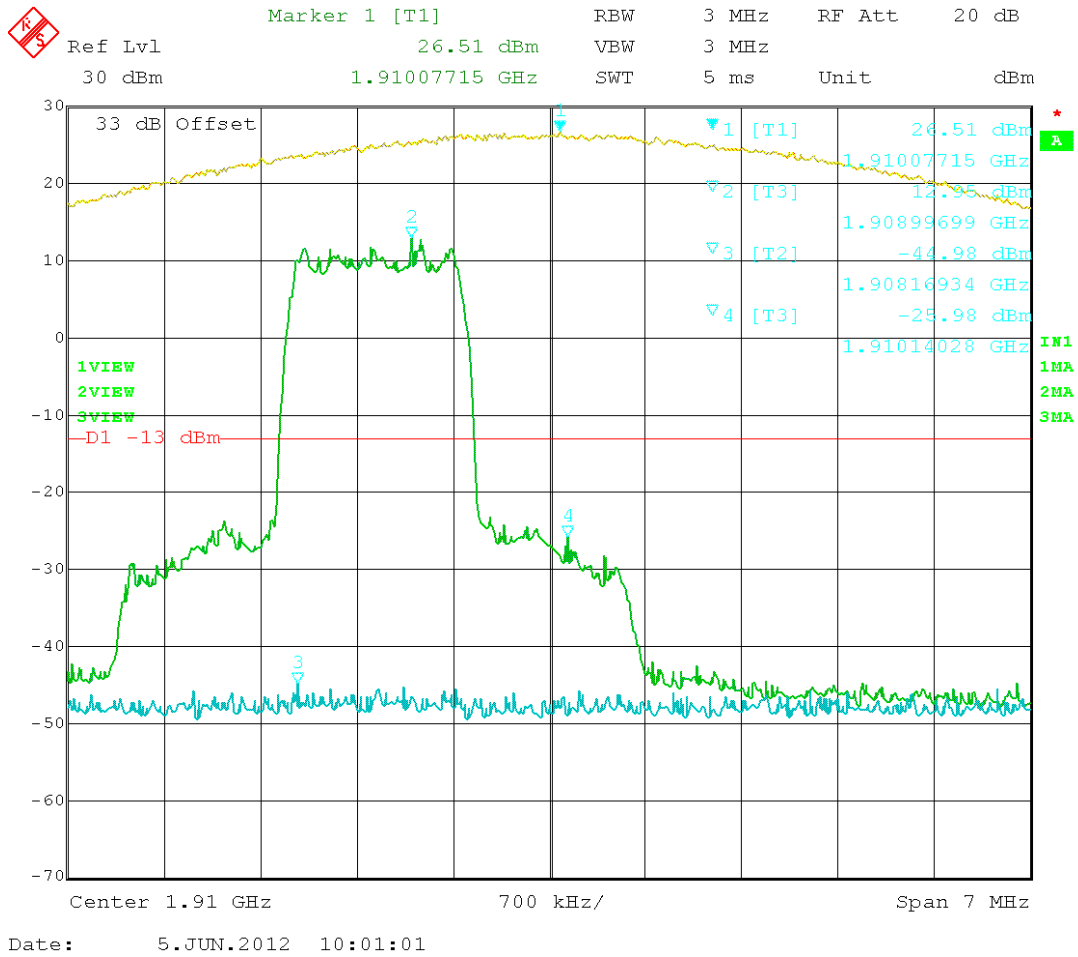

Figure 2: CDMA – In vs. Out 1908.75MHz

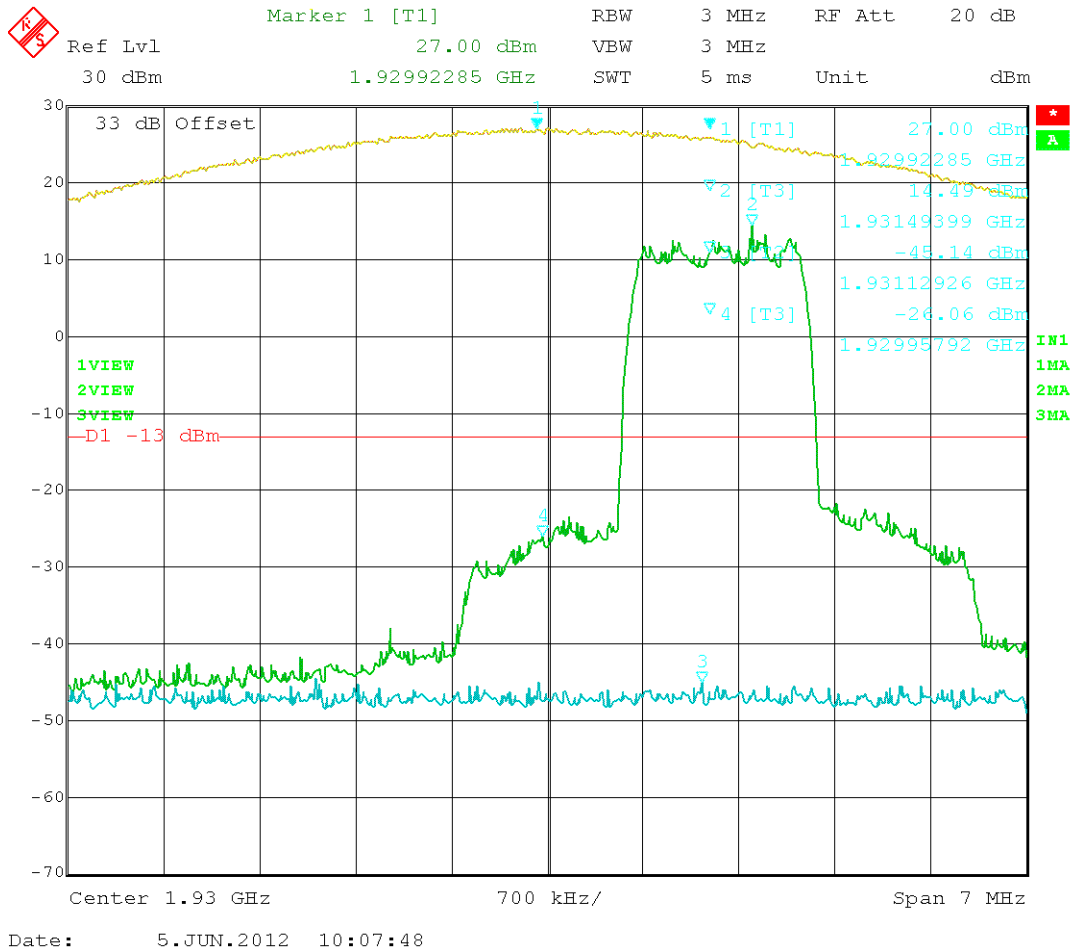

Figure 3: CDMA – In vs. Out 1931.25MHz

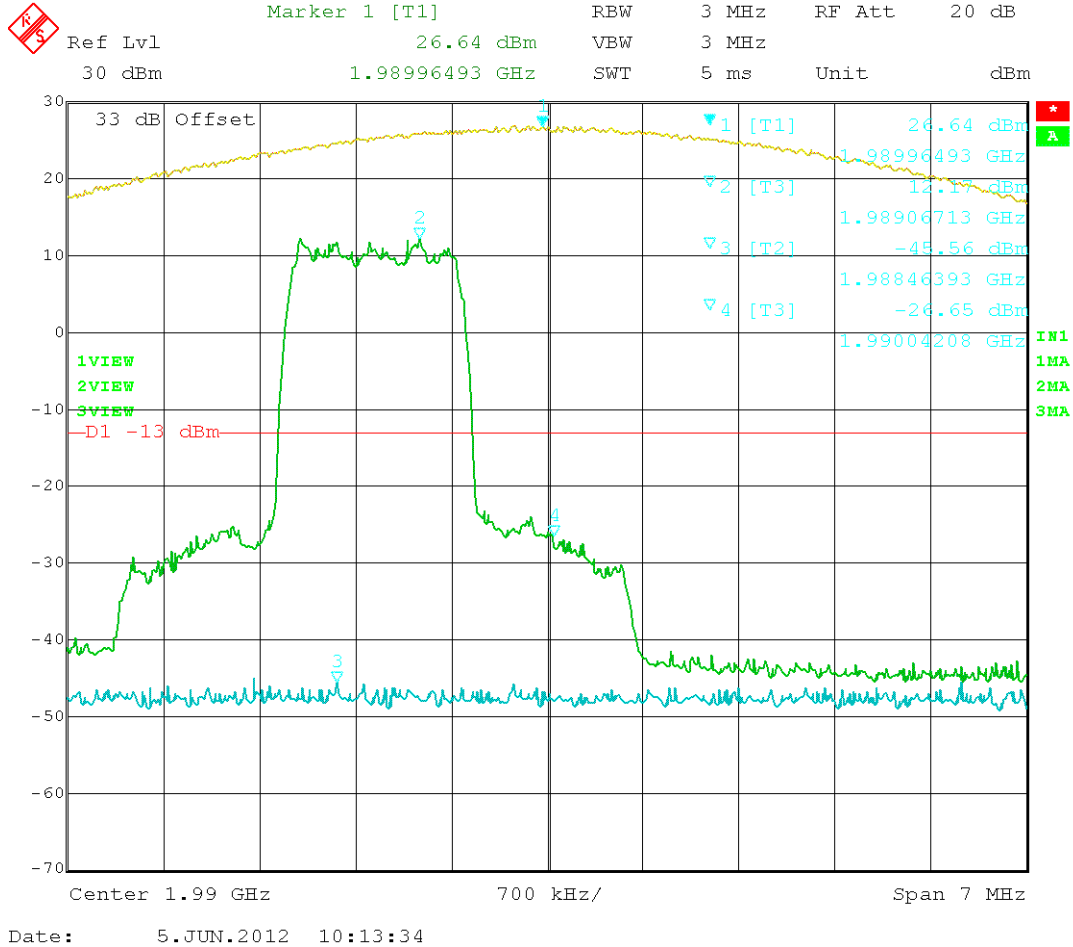

Figure 4: CDMA – In vs. Out 1988.75MHz

Test Data Table 13 – HSPA 1900 – Uplink/Downlink

Channel (MHz)	Bandedge Frequency (MHz)	Amplitude bandedge (dBm)	Limit (dBm)	Margin (dB)
1852.5	1849.88	-24.62	-13	11.62
1907.5	1910.16	-27.68	-13	14.68
1932.5	1929.88	-27.76	-13	14.76
1987.5	1990.08	-28.91	-13	15.91

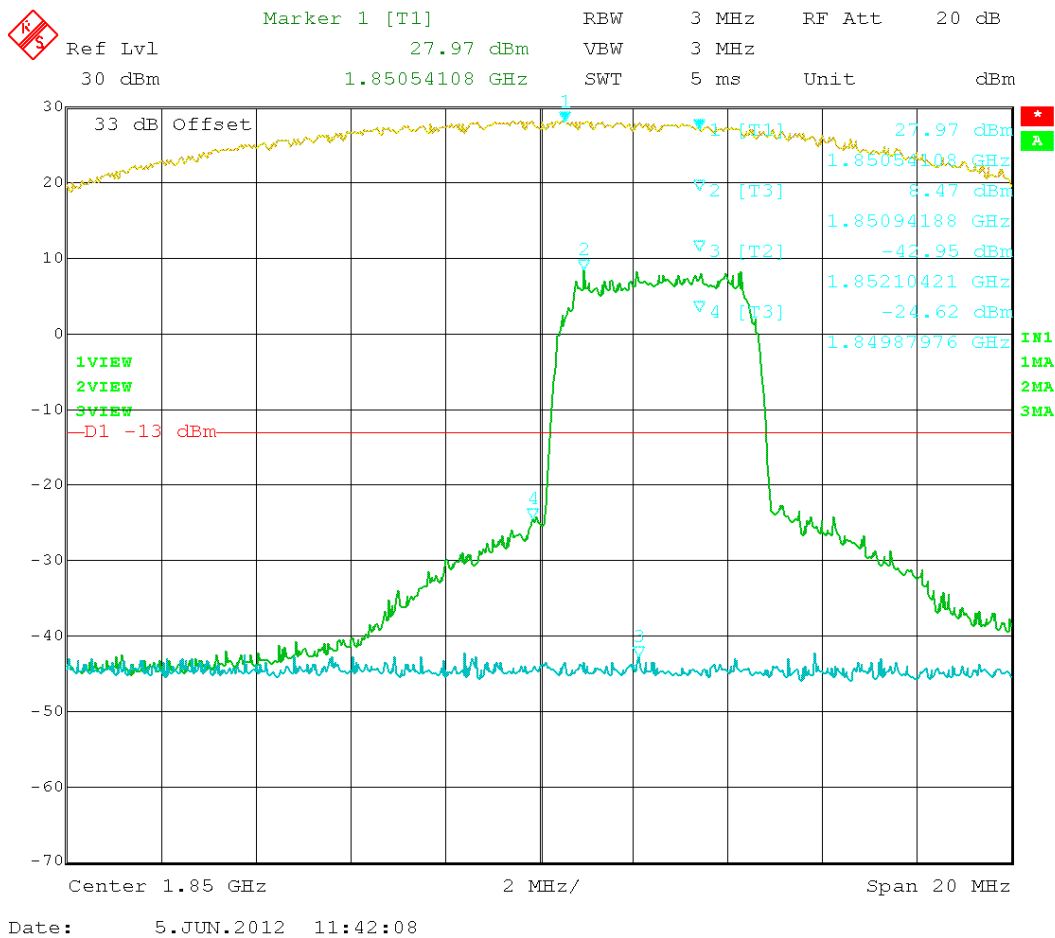

Figure 5: HSPA – In vs. Out 1852.50 MHz

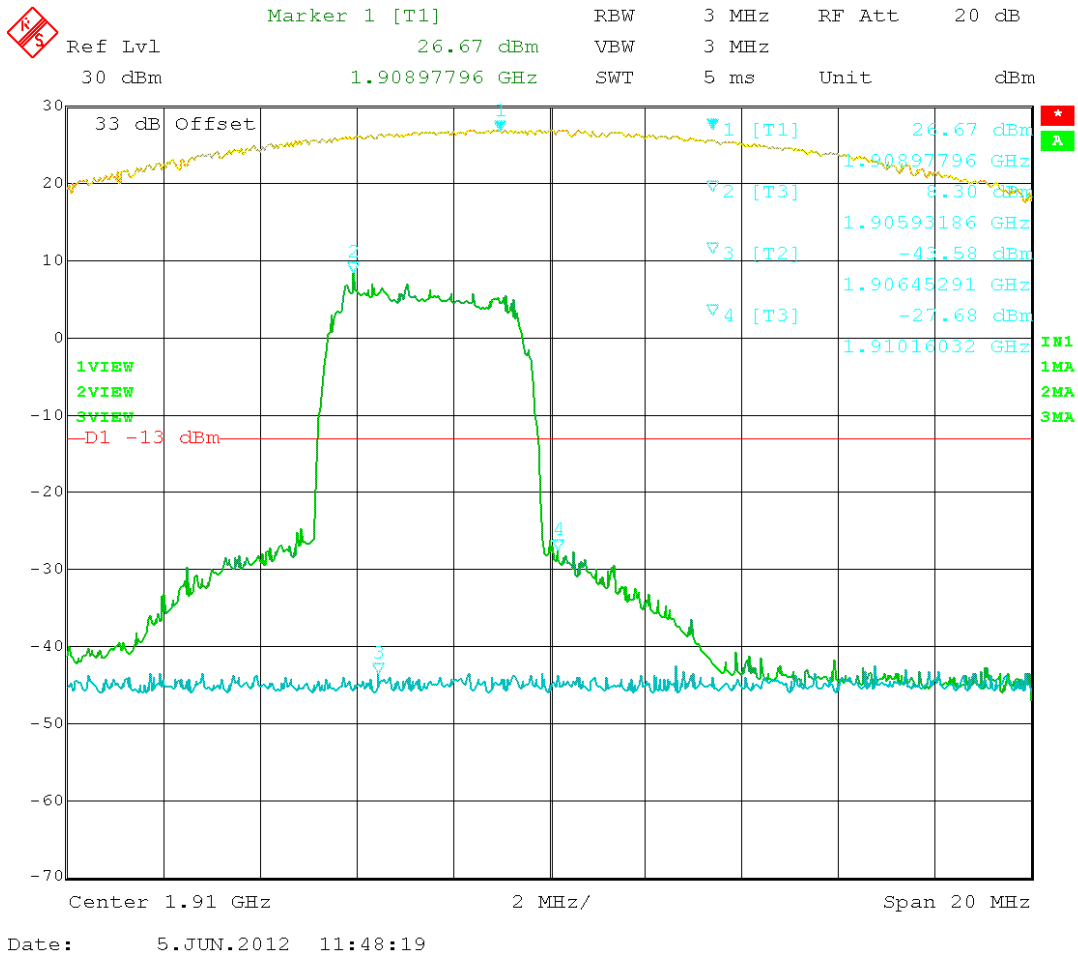

Figure 6: HSPA – In vs. Out 1907.50 MHz

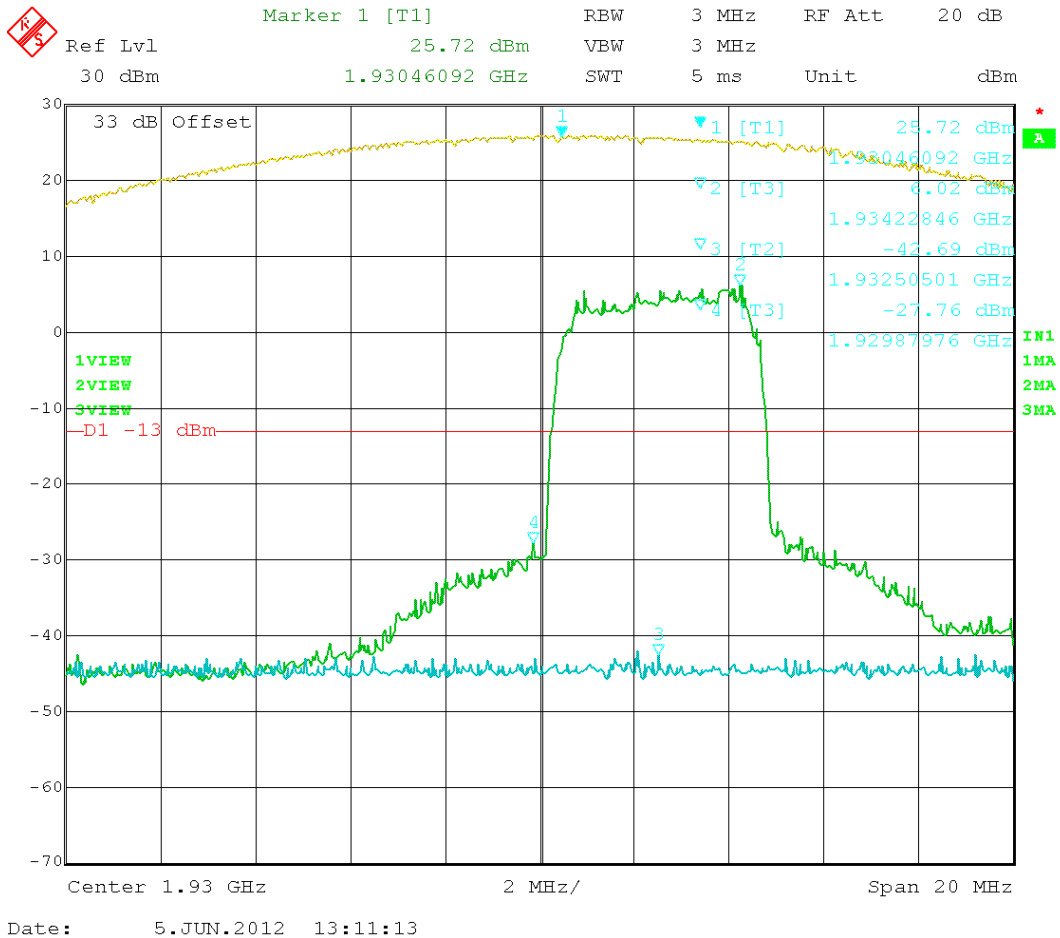

Figure 7: HSPA – In vs. Out 1932.50 MHz

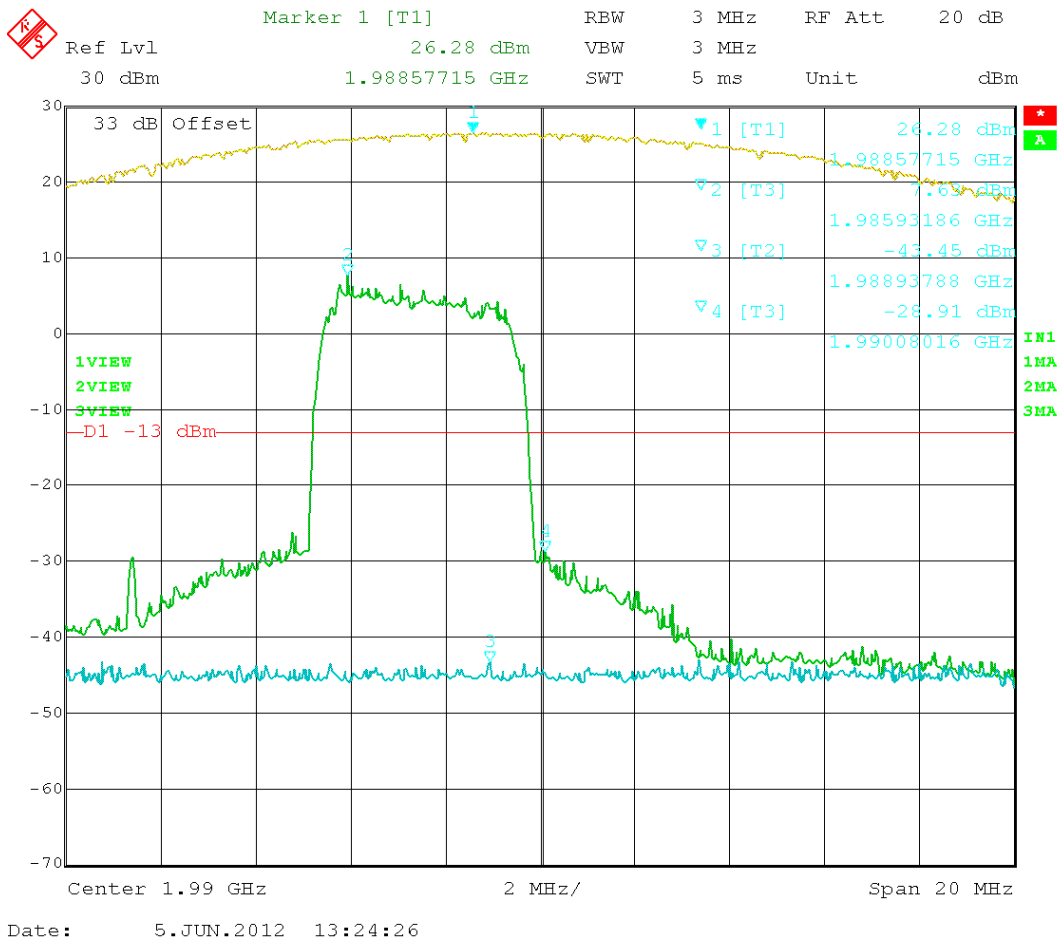

Figure 8: HSPA – In vs. Out 1977.50 MHz

Test Data Table 14 – LTE 1900 – Uplink/Downlink

Channel (MHz)	Band-edge Frequency (MHz)	Amplitude level at the band-edge (dBm)	Limit (dBm)	Margin (dB)
1855.0	1849.12	-27.16	-13	14.16
1905.0	1910.4	-30.36	-13	17.36
1935.0	1928.59	-32.74	-13	19.74
1985.0	1990.8	-35.80	-13	22.8

The Reference level on the following plots was calibrated using a 3MHz RBW=VBW.

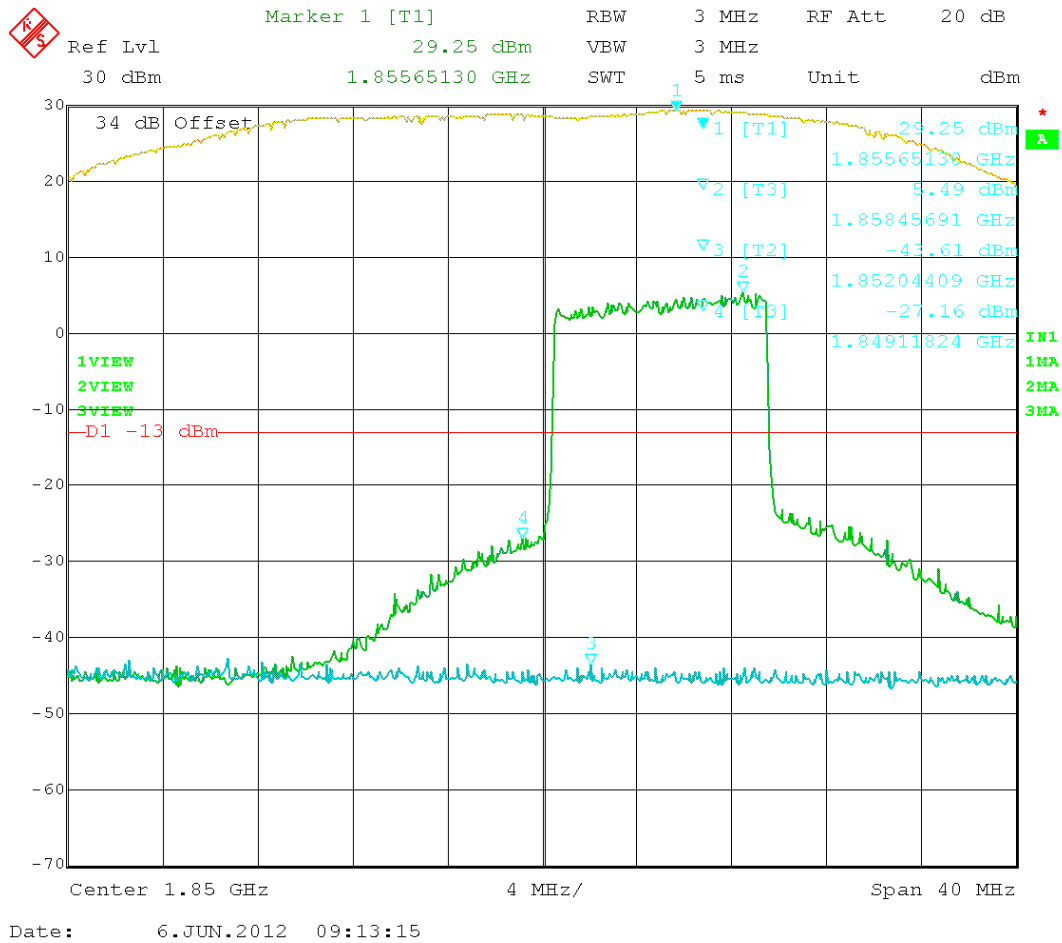

Figure 9: LTE – In vs. Out 1855.00MHz

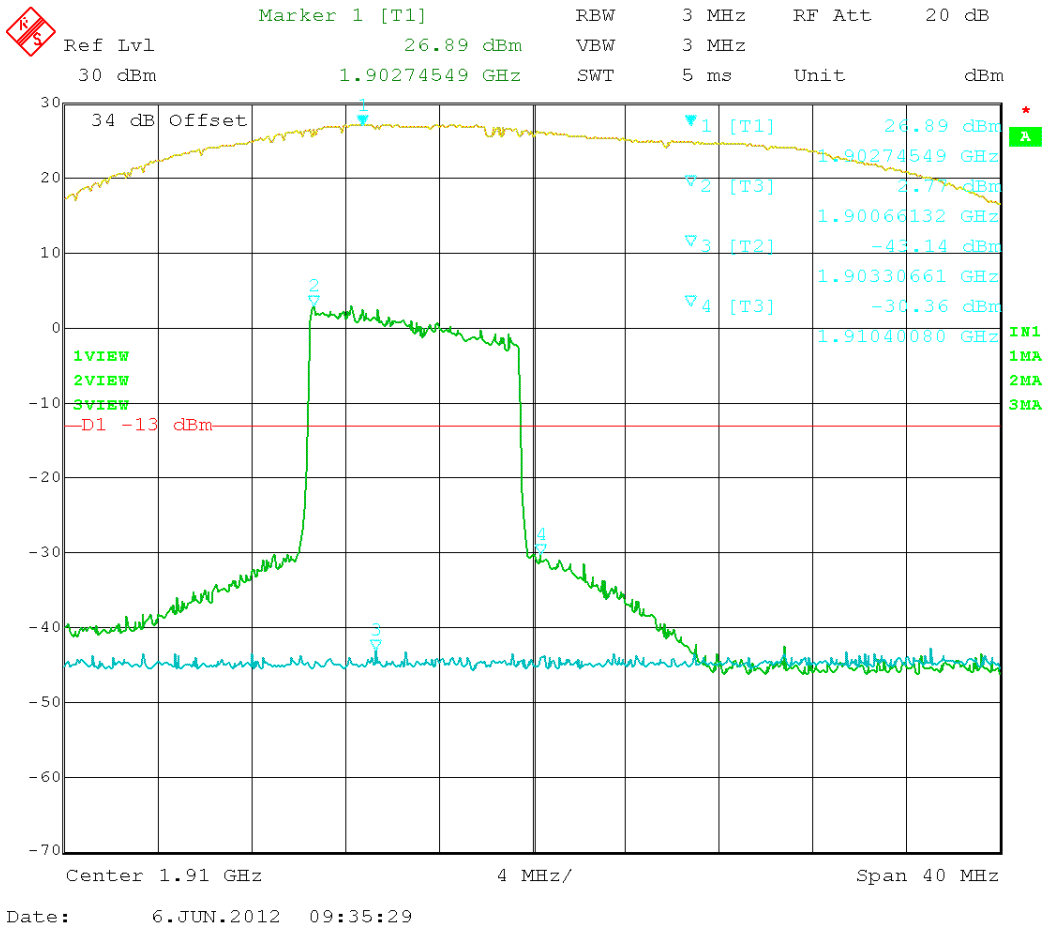

Figure 10: LTE – In vs. Out 1905.00MHz

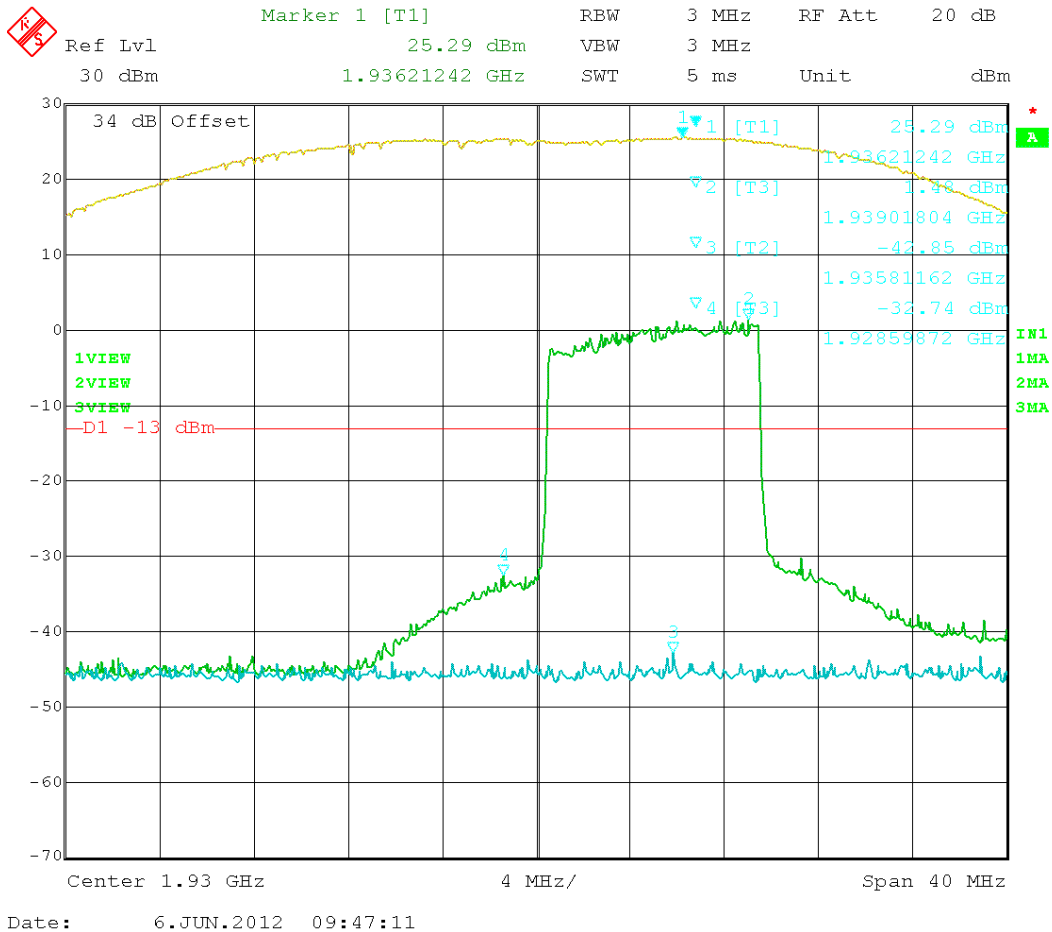

Figure 11: LTE – In vs. Out 1935.00MHz

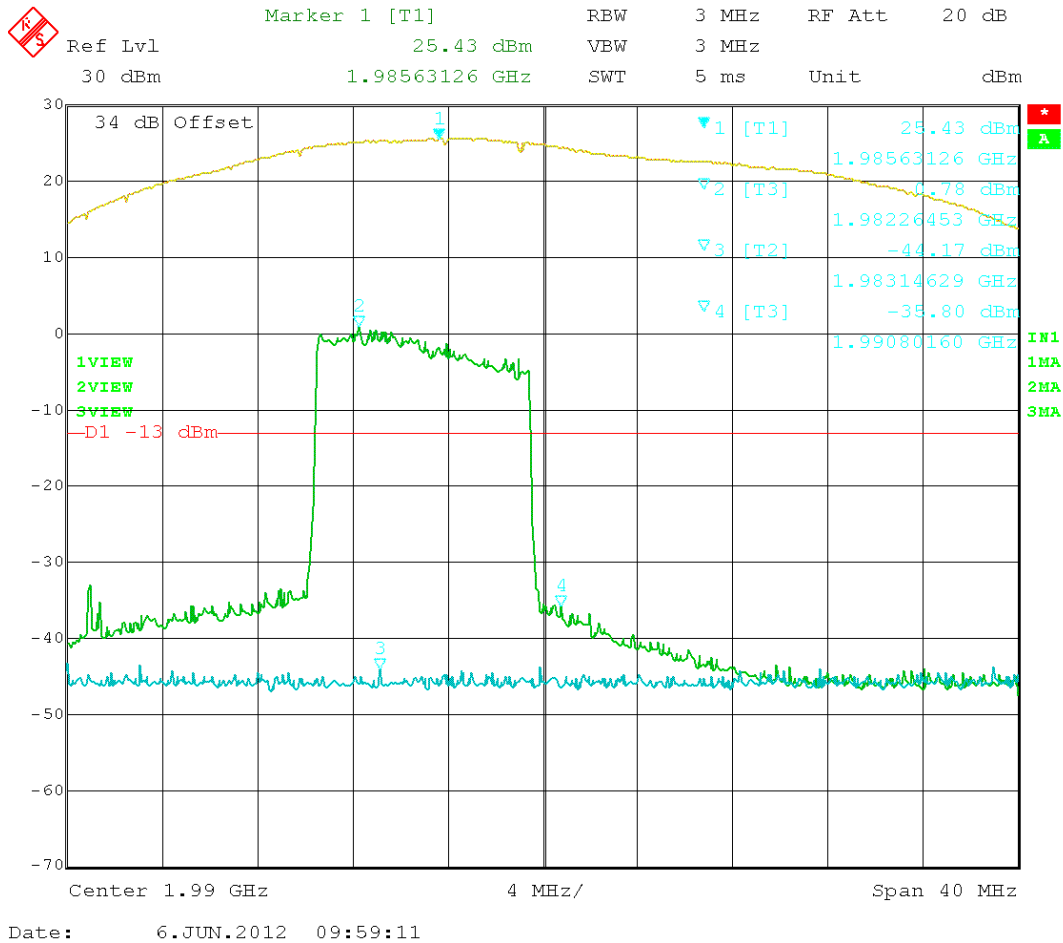

Figure 12: LTE – In vs. Out 1985.00MHz

Test Data Table 15 –GSM 1900 – Uplink/Downlink

Channel (MHz)	Band-edge Frequency (MHz)	Amplitude level at the band-edge (dBm)	Limit (dBm)	Margin (dB)
1850.2	1849.98	-13.92	-13	0.92
1909.8	1910.02	-15.46	-13	2.46
1930.2	1929.98	-18.07	-13	5.07
1989.8	1990.02	-17.04	-13	4.04

The Reference level on the following plots was calibrated using a 3MHz RBW=VBW.

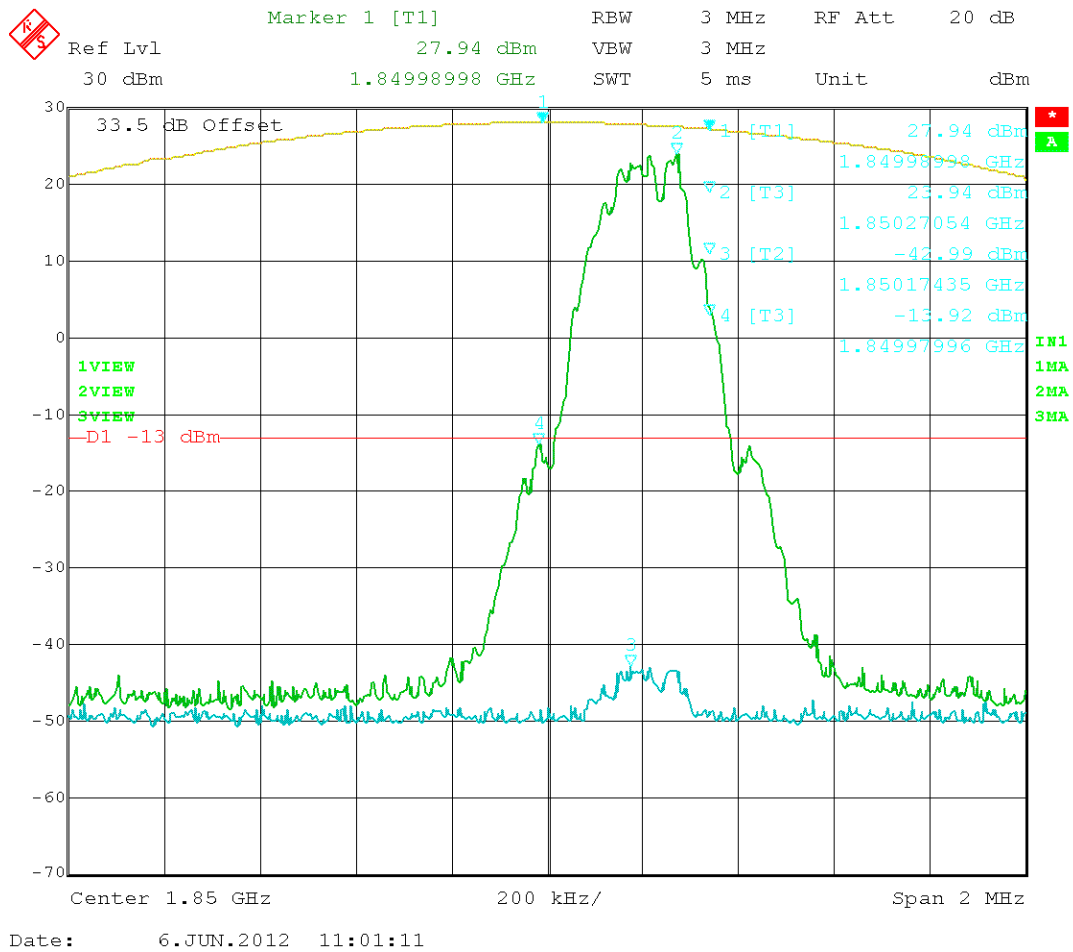

Figure 13: GSM – In vs. Out 1850.20MHz

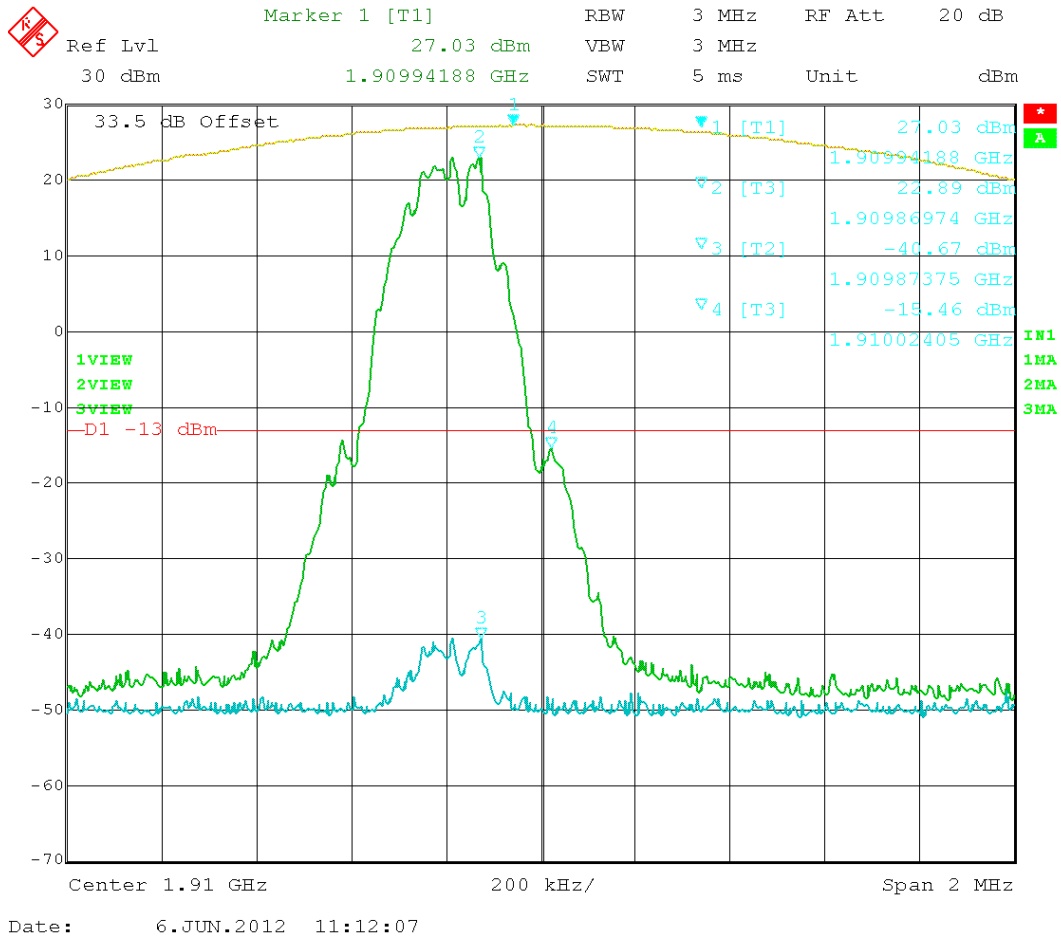

Figure 14: GSM – In vs. Out 1909.80MHz

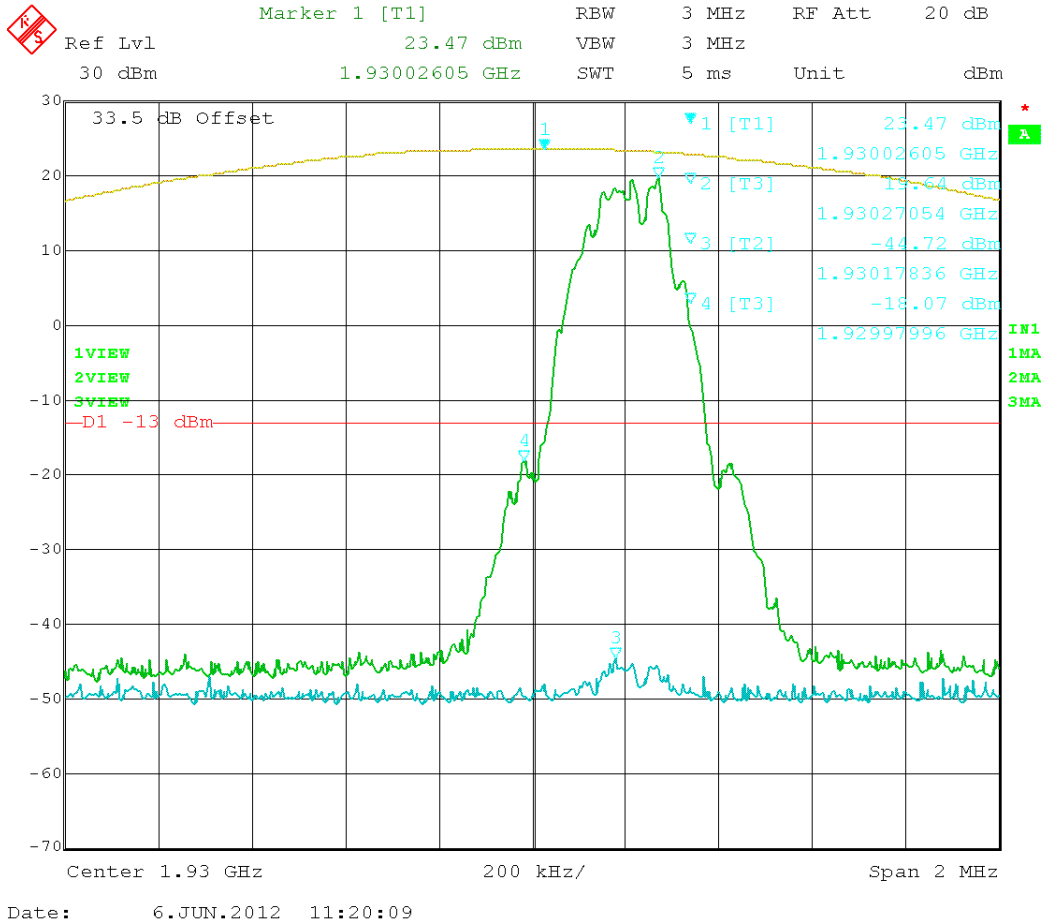

Figure 15: GSM – In vs. Out 1930.20MHz

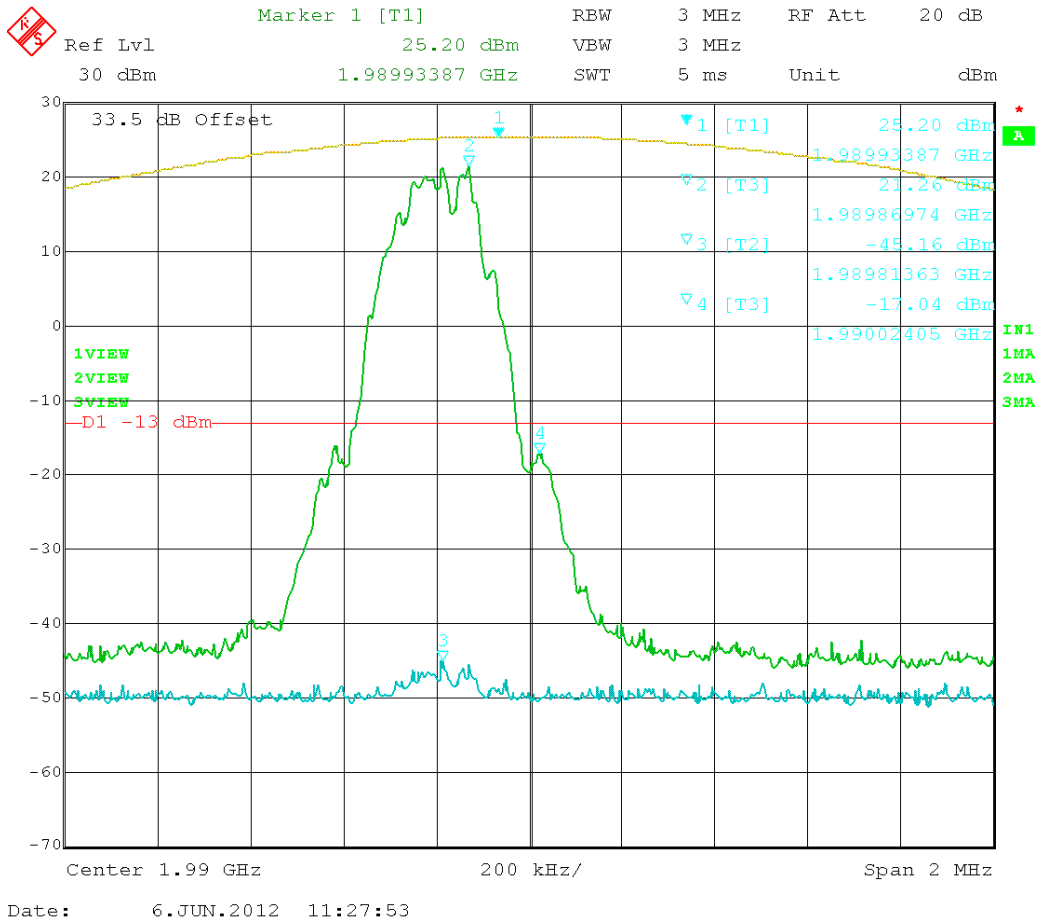

Figure 16: GSM – In vs. Out 1989.80MHz

Test Data Table 16 – EDGE 1900 – Uplink/Downlink

Channel (MHz)	Band-edge Frequency (MHz)	Amplitude level at the band-edge (dBm)	Limit (dBm)	Margin (dB)
1850.2	1849.98	-15.77	-13	2.77
1909.8	1910.02	-19	-13	6
1930.2	1929.98	-15.28	-13	2.28
1989.8	1990.01	-19.78	-13	6.78

The Reference level on the following plots was calibrated using a 3MHz RBW=VBW.

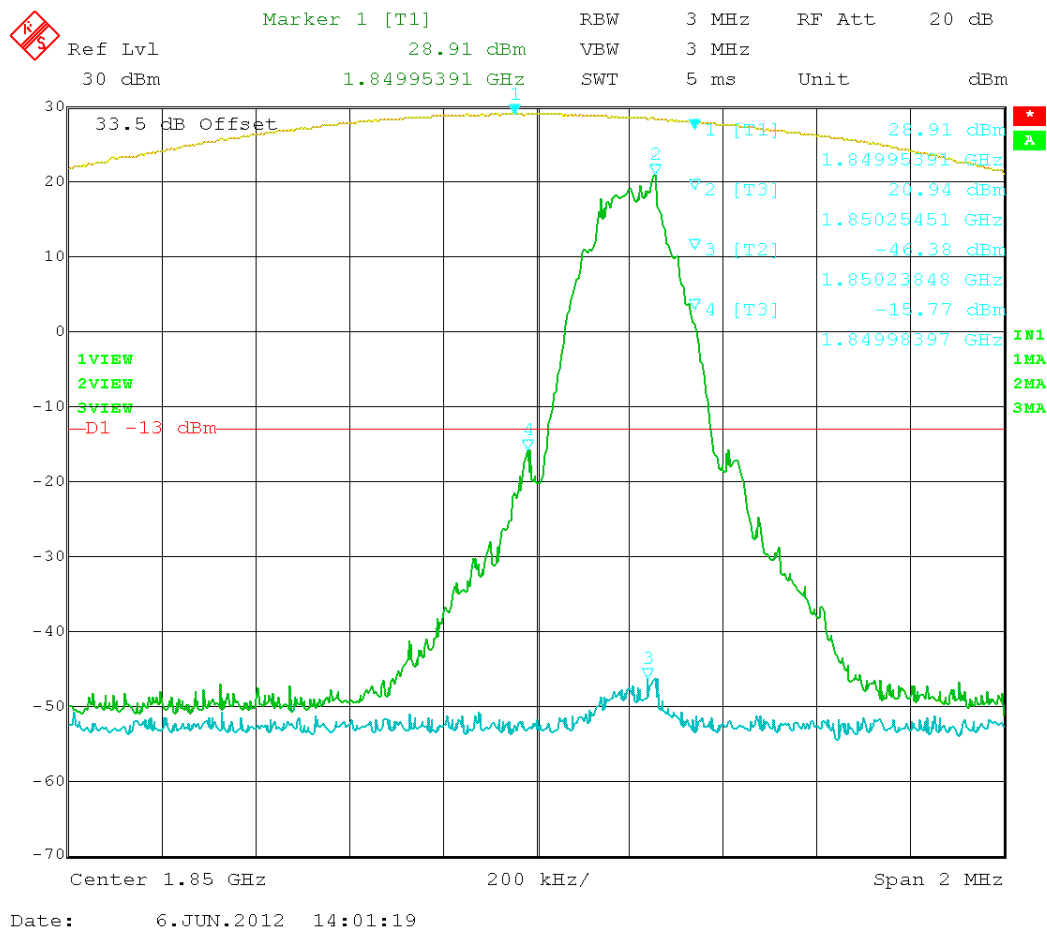

Figure 17: EDGE – In vs. Out 1850.20MHz

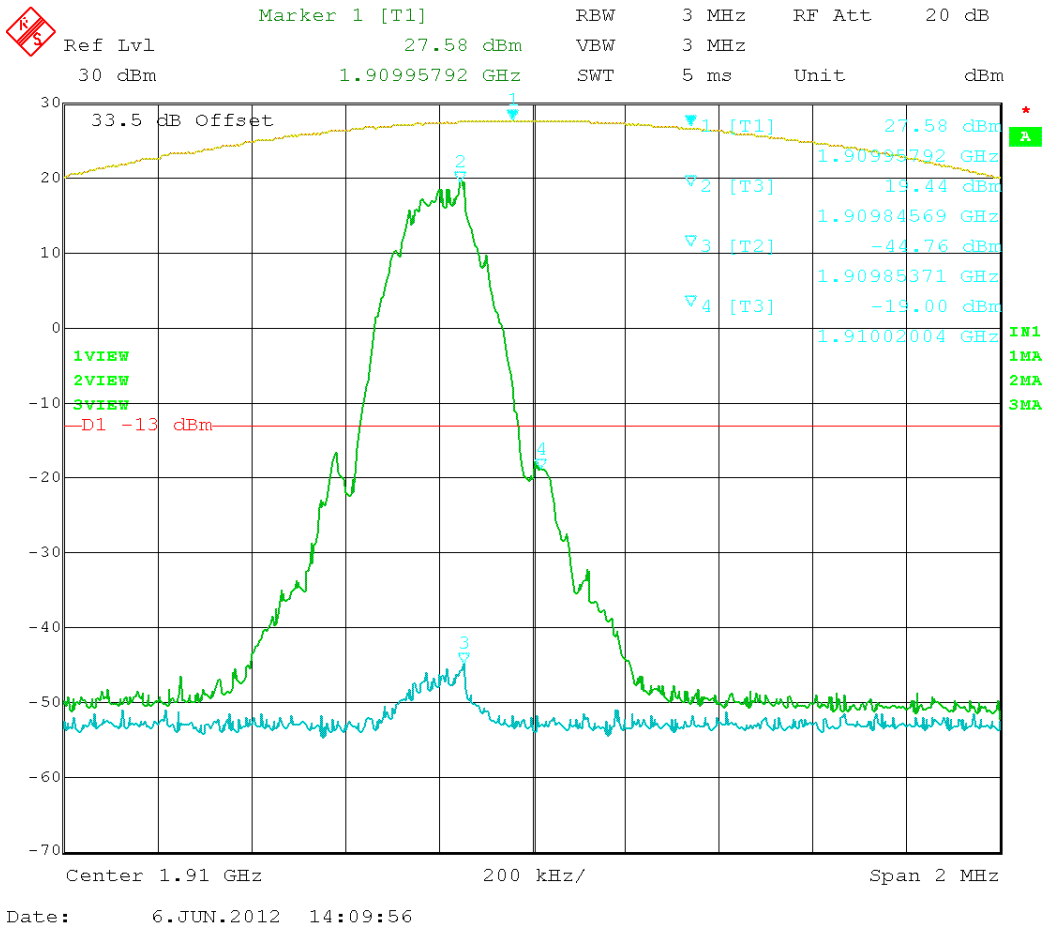

Figure 18: EDGE – In vs. Out 1909.80MHz

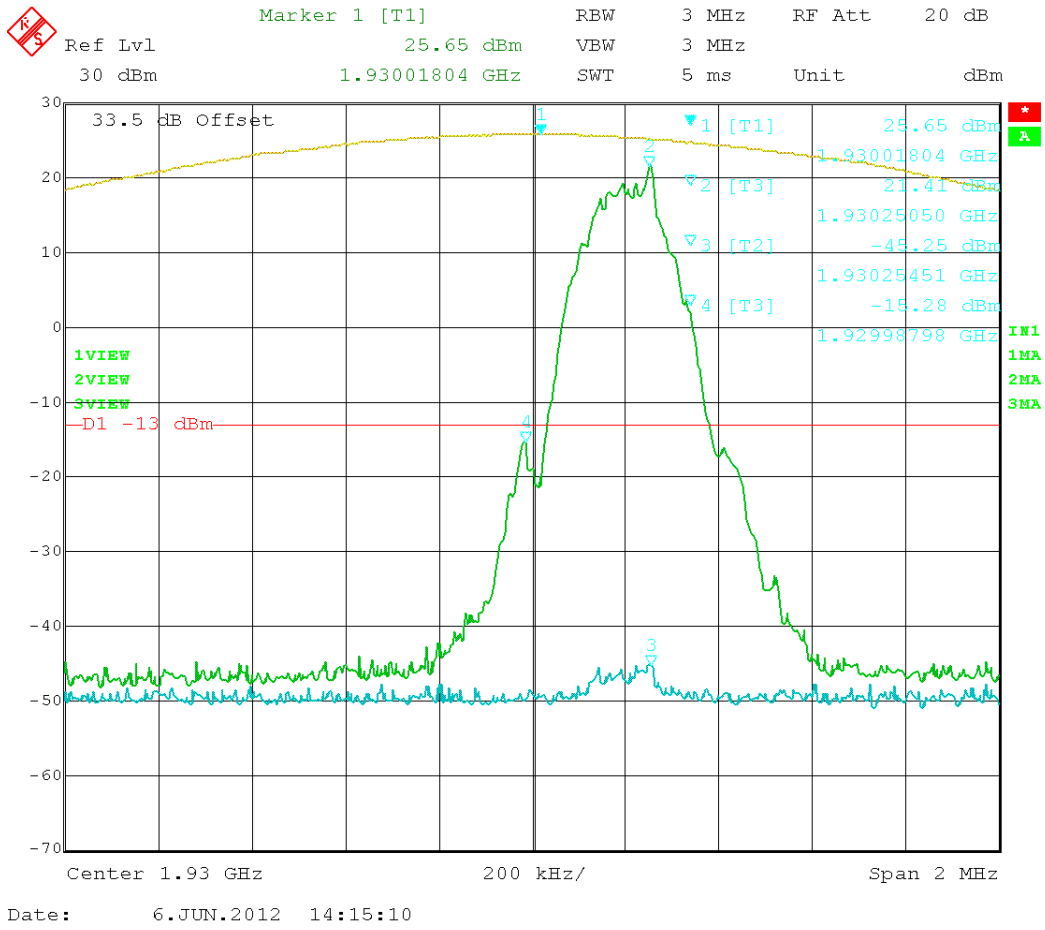

Figure 19: EDGE – In vs. Out 1930.20MHz

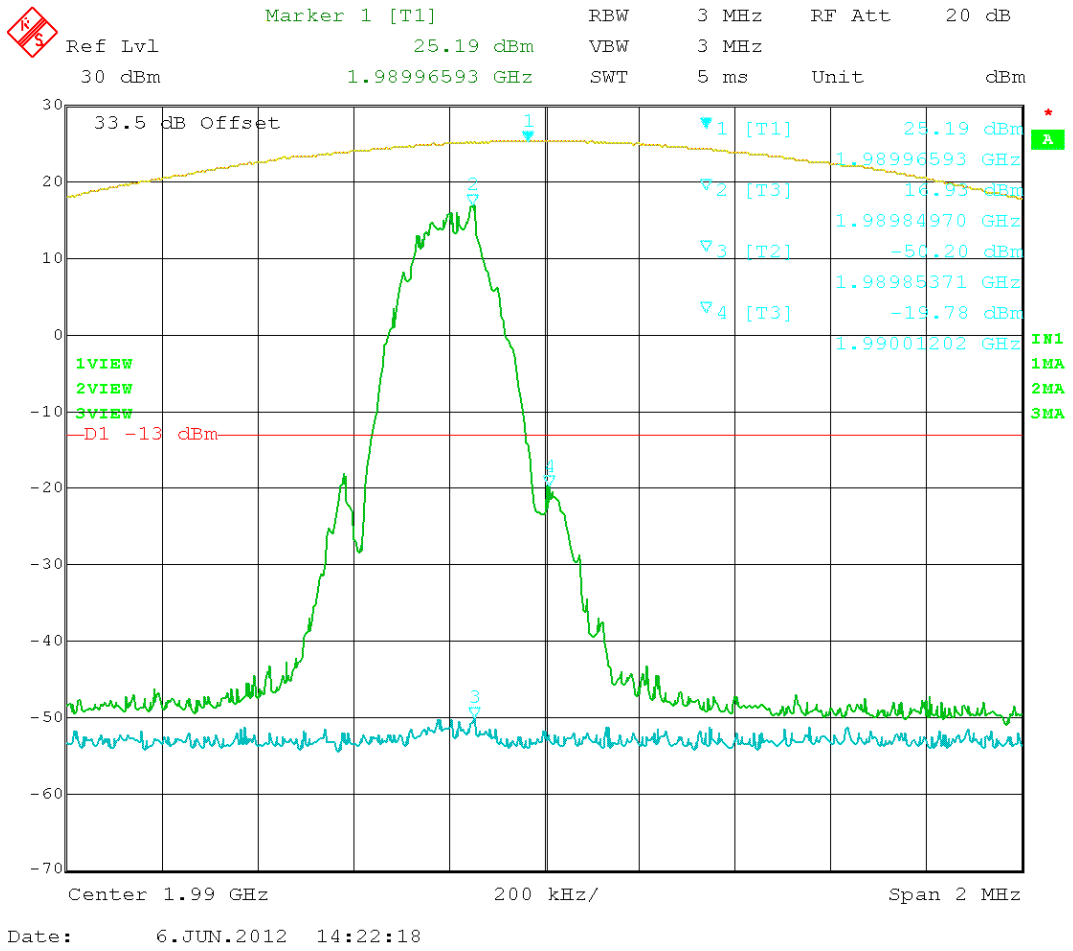

Figure 20: EDGE – In vs. Out 1989.80MHz

Compensating for RBW (1%) using $10 \log(12.5/3) = 6.2$ dB we get the following amplitudes at the bandedge:

Test Data Table 17 – CDMA 800 – Uplink/Downlink

Channel (MHz)	Bandedge Frequency (MHz)	Amplitude level at the band-edge (dBm)	Limit (dBm)	Margin (dB)
825.25	823.96	-27.77	-13	14.77
847.75	849.09	-28.42	-13	15.42
870.25	868.82	-36.25	-13	23.25
892.75	894.13	-35.11	-13	22.11

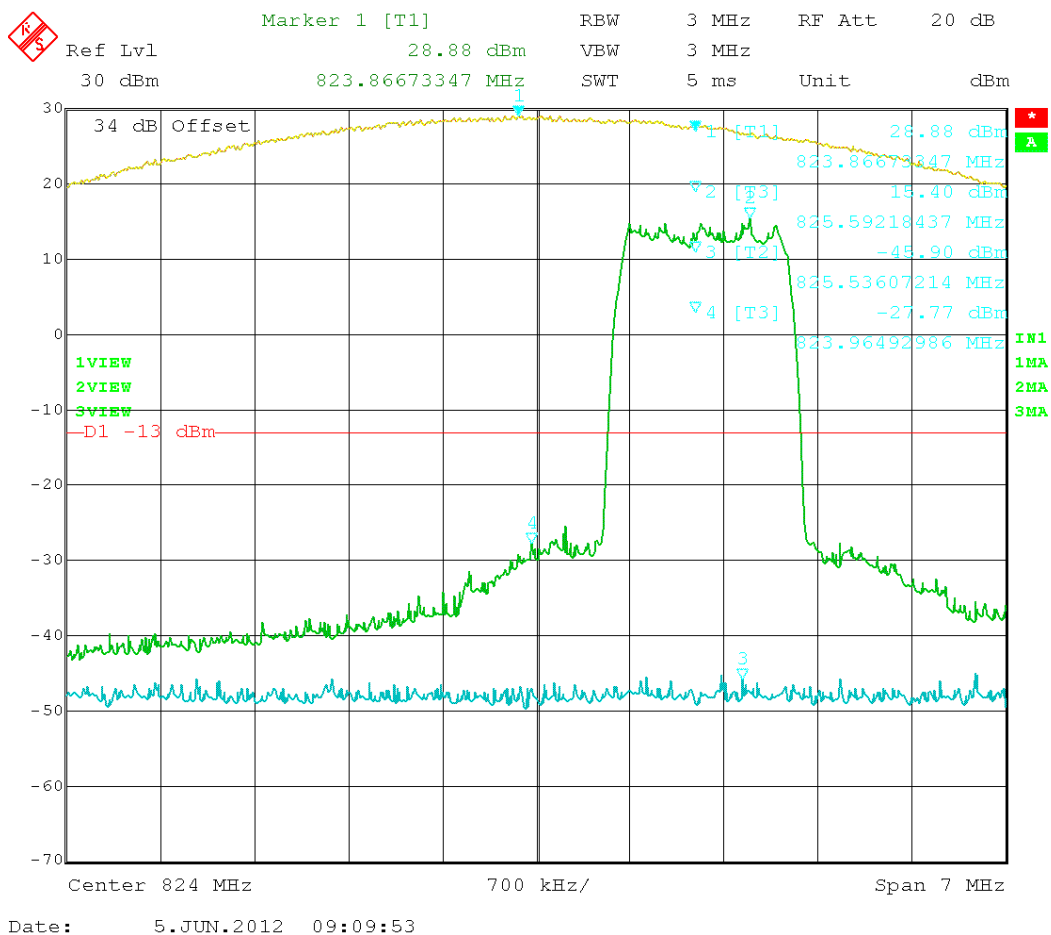

Figure 21: CDMA – In vs. Out 825.25MHz

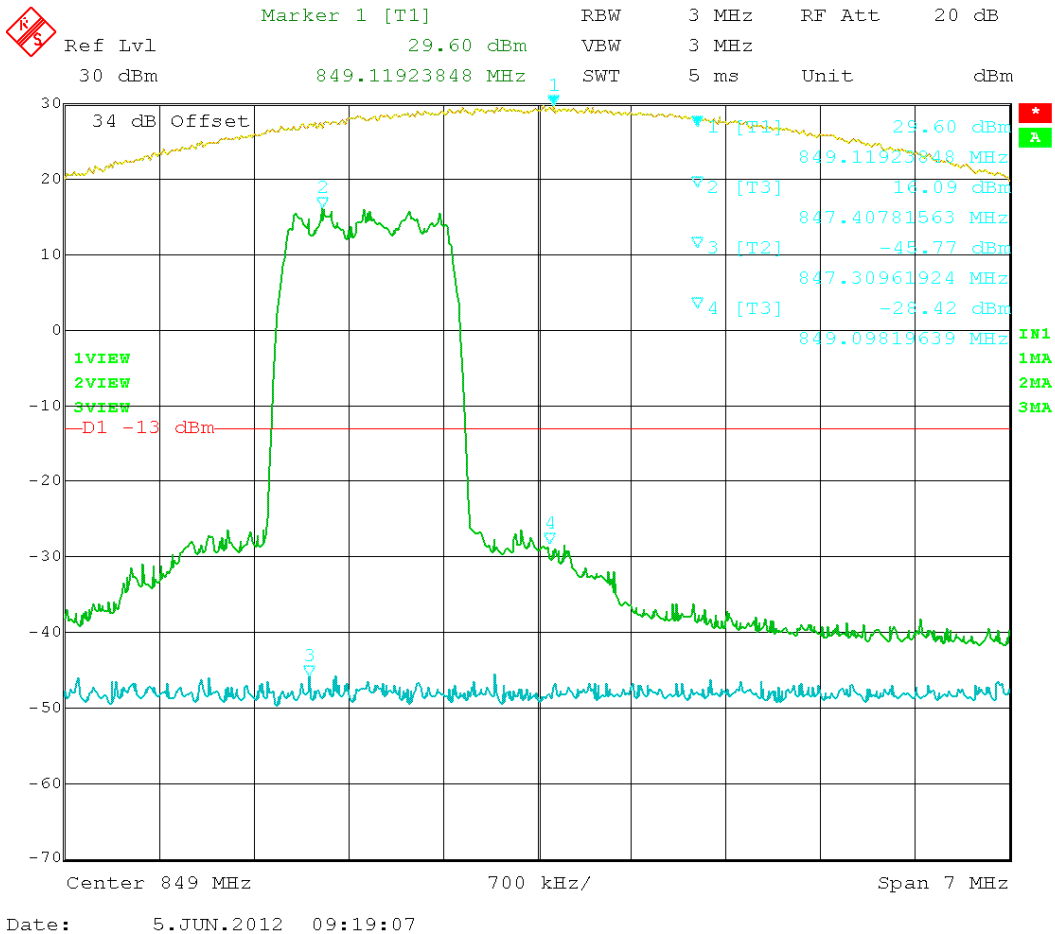

Figure 22: CDMA – In vs. Out 847.75 MHz

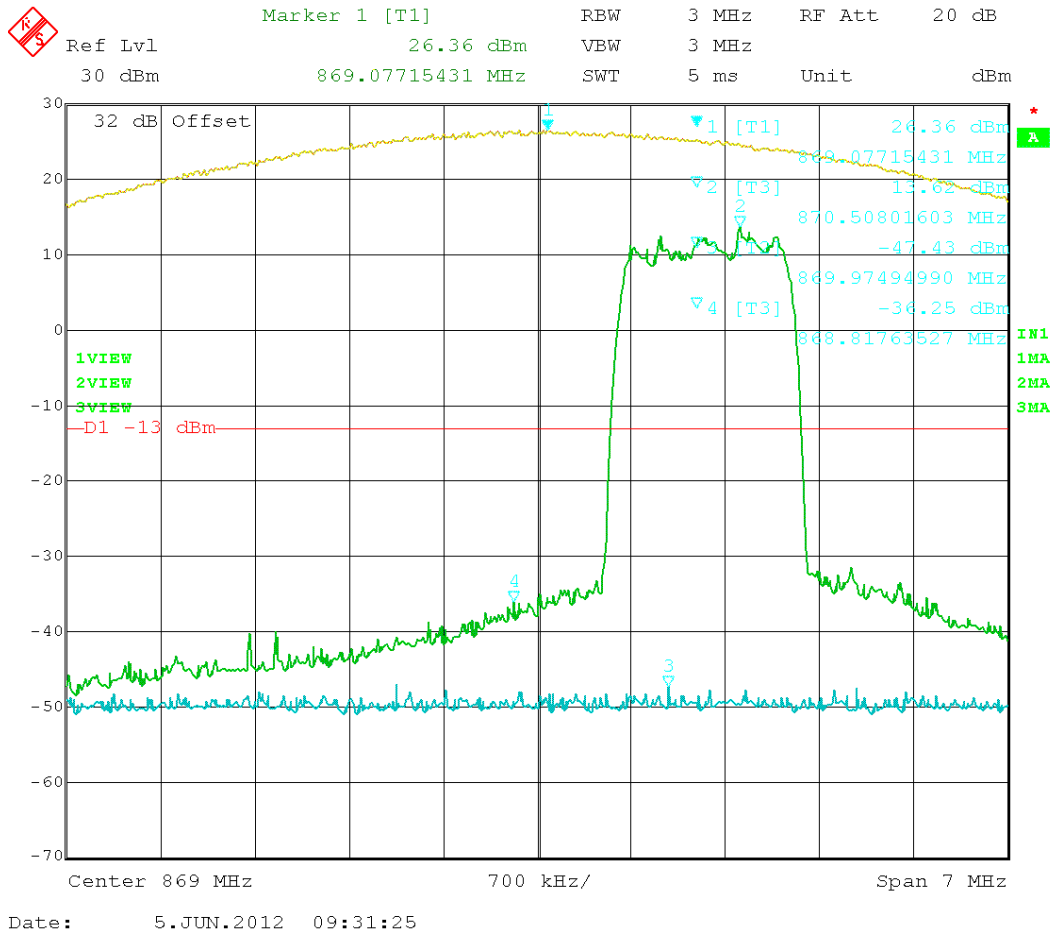
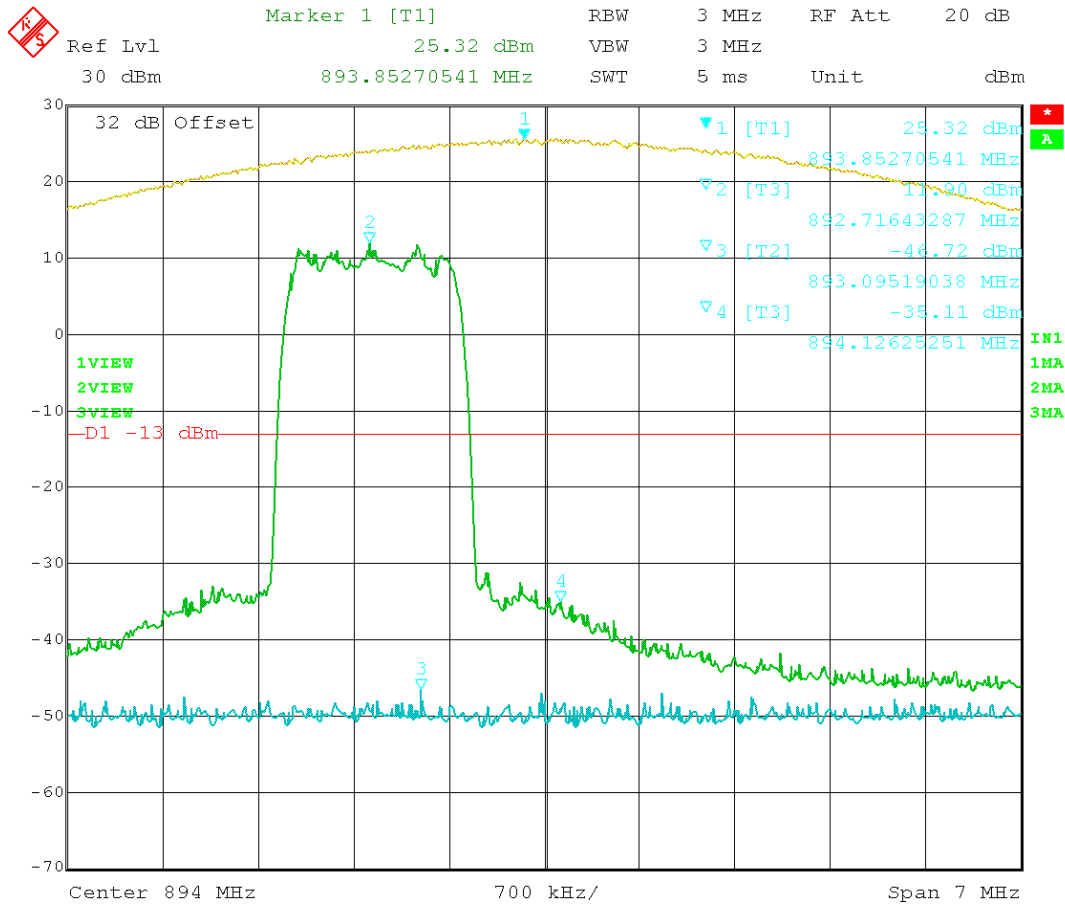

Figure 23: CDMA – In vs. Out 870.25 MHz



Date: 5.JUN.2012 09:37:13

Figure 24: CDMA – In vs. Out 892.75 MHz

Test Data Table 18 – HSPA 800 – Uplink/Downlink

Channel (MHz)	Bandedge Frequency (MHz)	Amplitude level at the band-edge (dBm)	Limit (dBm)	Margin (dB)
826.5	823.79	-27.42	-13	14.42
846.5	849.24	-26.97	-13	13.97
871.5	868.76	-34.82	-13	21.82
891.5	894.20	-33.92	-13	20.92

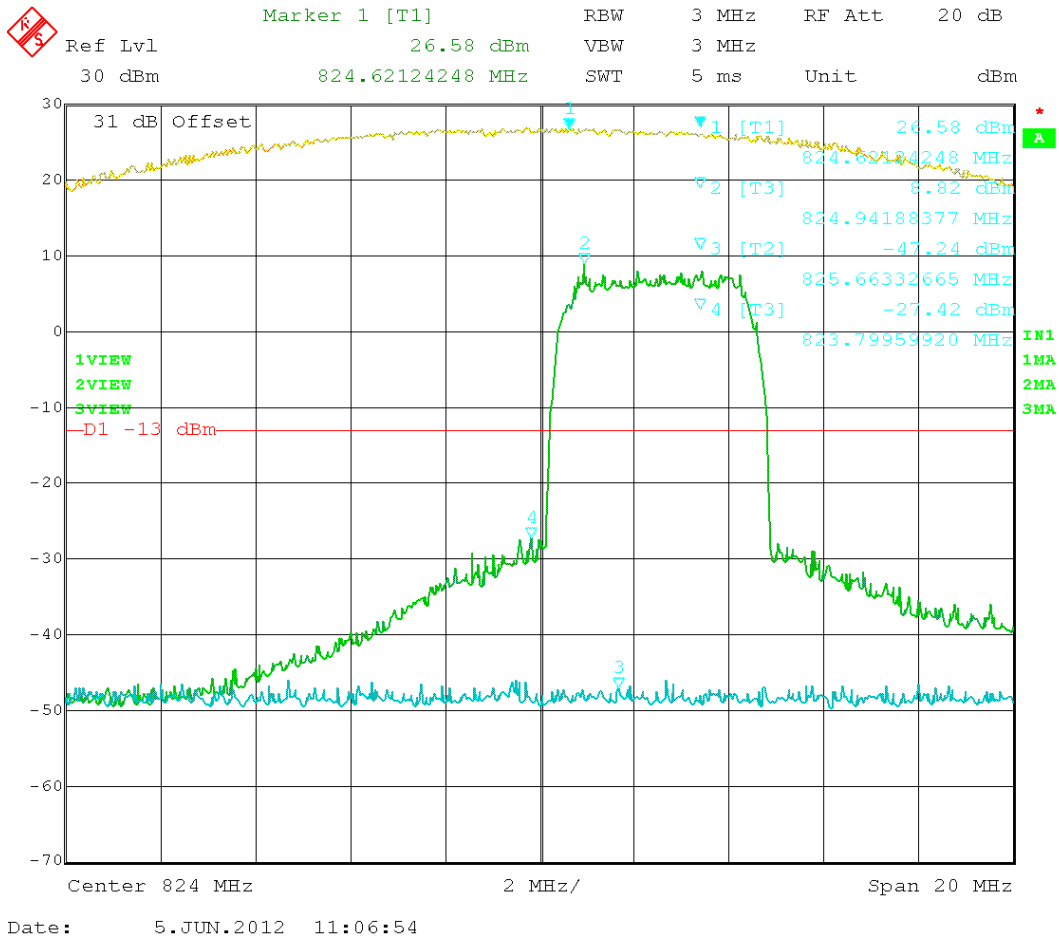

Figure 25: HSPA – In vs. Out 826.50 MHz

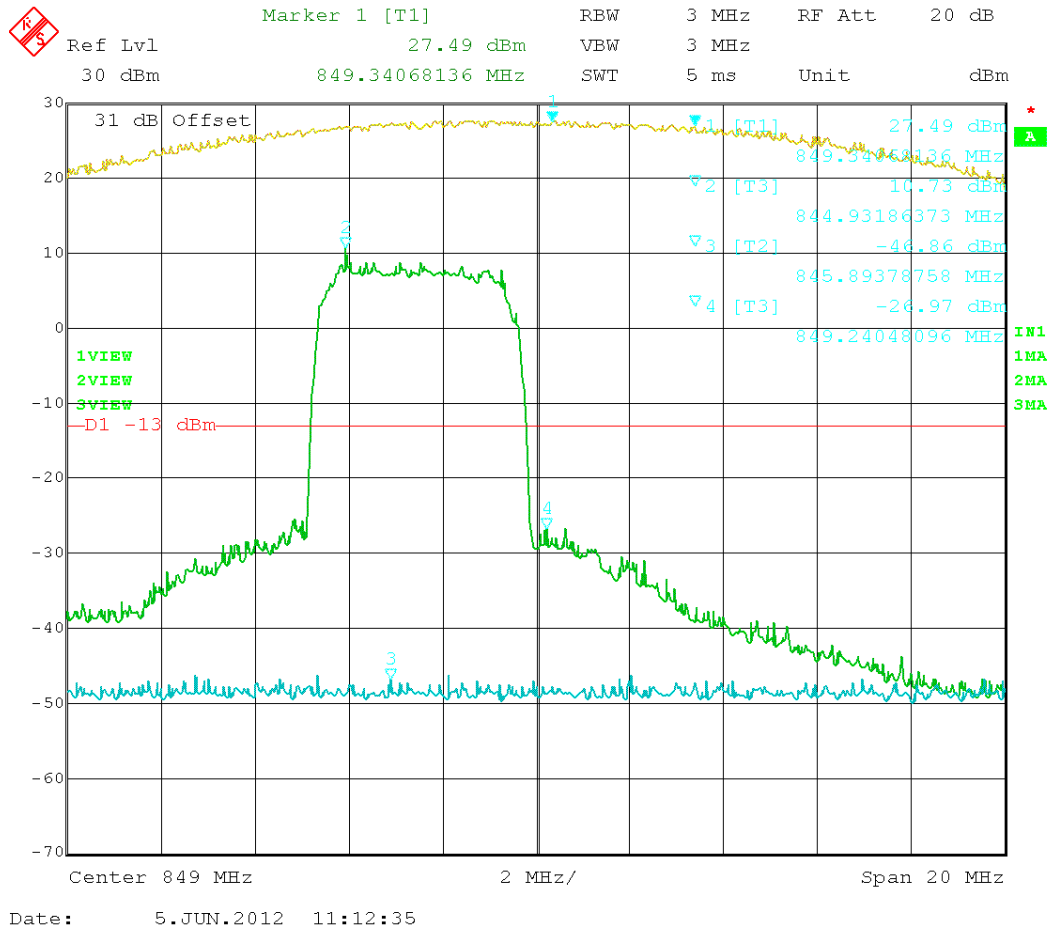

Figure 26: HSPA – In vs. Out 846.50 MHz

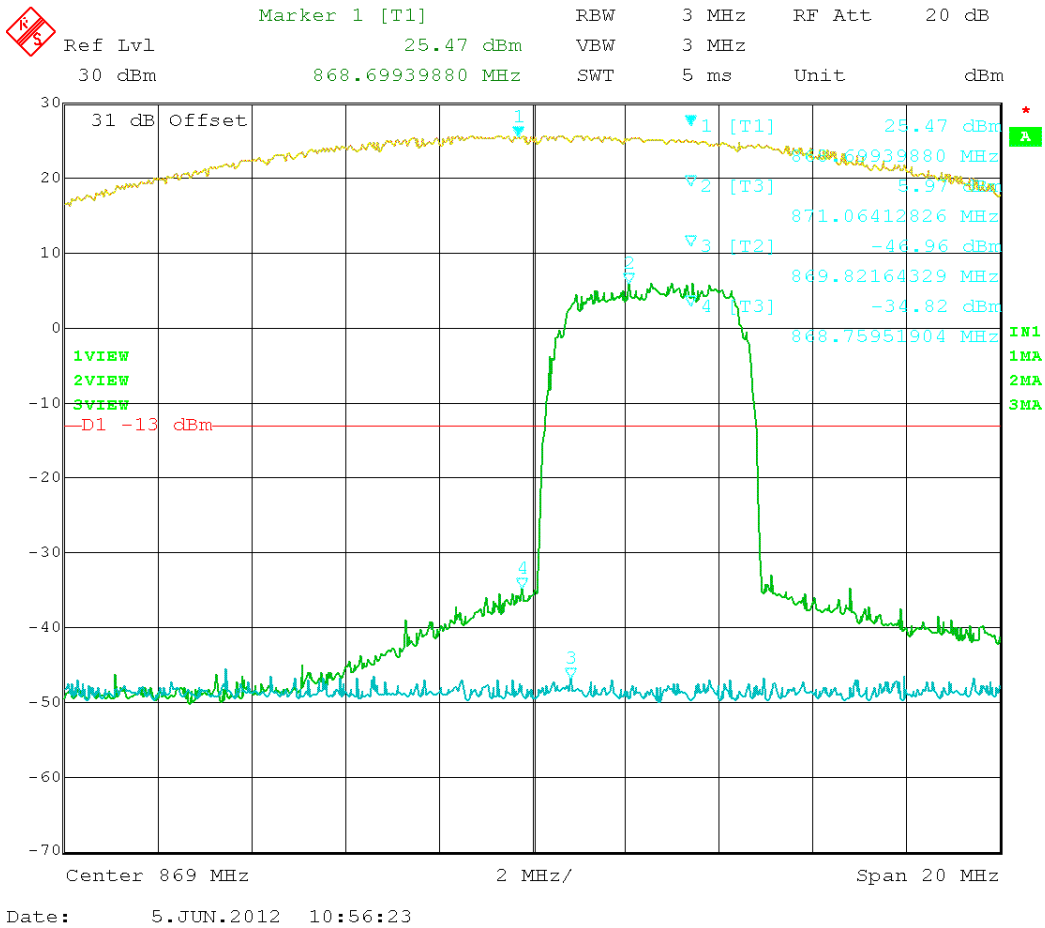

Figure 27: HSPA – In vs. Out 871.50 MHz

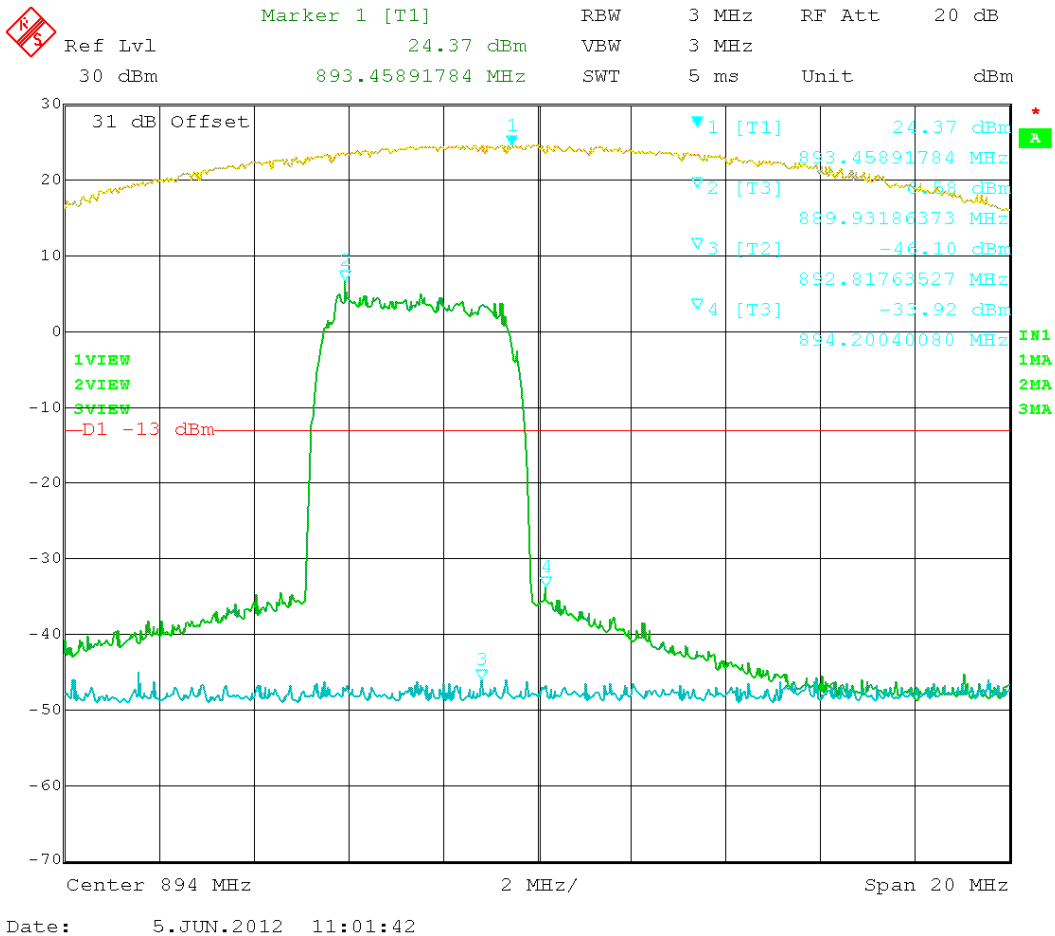

Figure 28: HSPA – In vs. Out 891.50 MHz

Test Data Table 19 – LTE 800 – Uplink/Downlink

Channel (MHz)	Band-edge Frequency (MHz)	Amplitude level at the band-edge (dBm)	Limit (dBm)	Margin (dB)
829.0	823.68	-28.33	-13	15.33
844.0	849.4	-33.44	-13	20.44
874.0	868.12	-33.79	-13	20.79
889.0	894.4	-36.70	-13	23.7

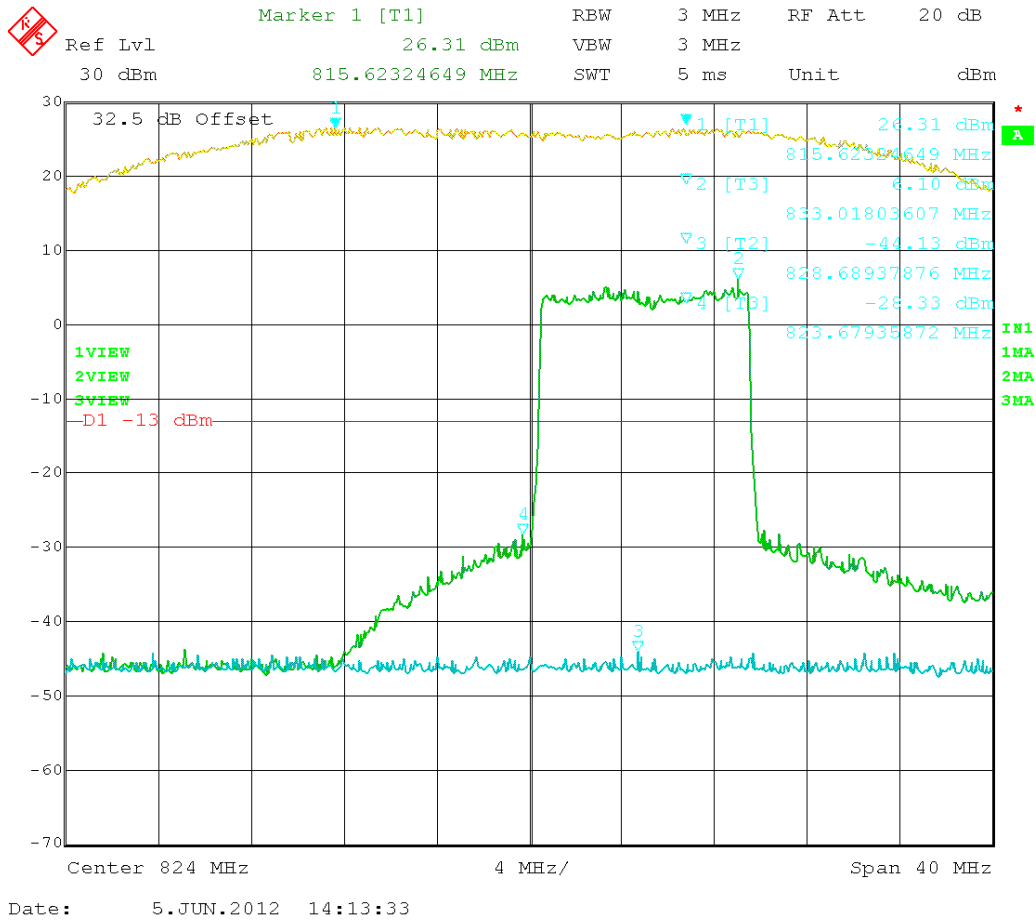

Figure 29: LTE – In vs. Out 829.00 MHz

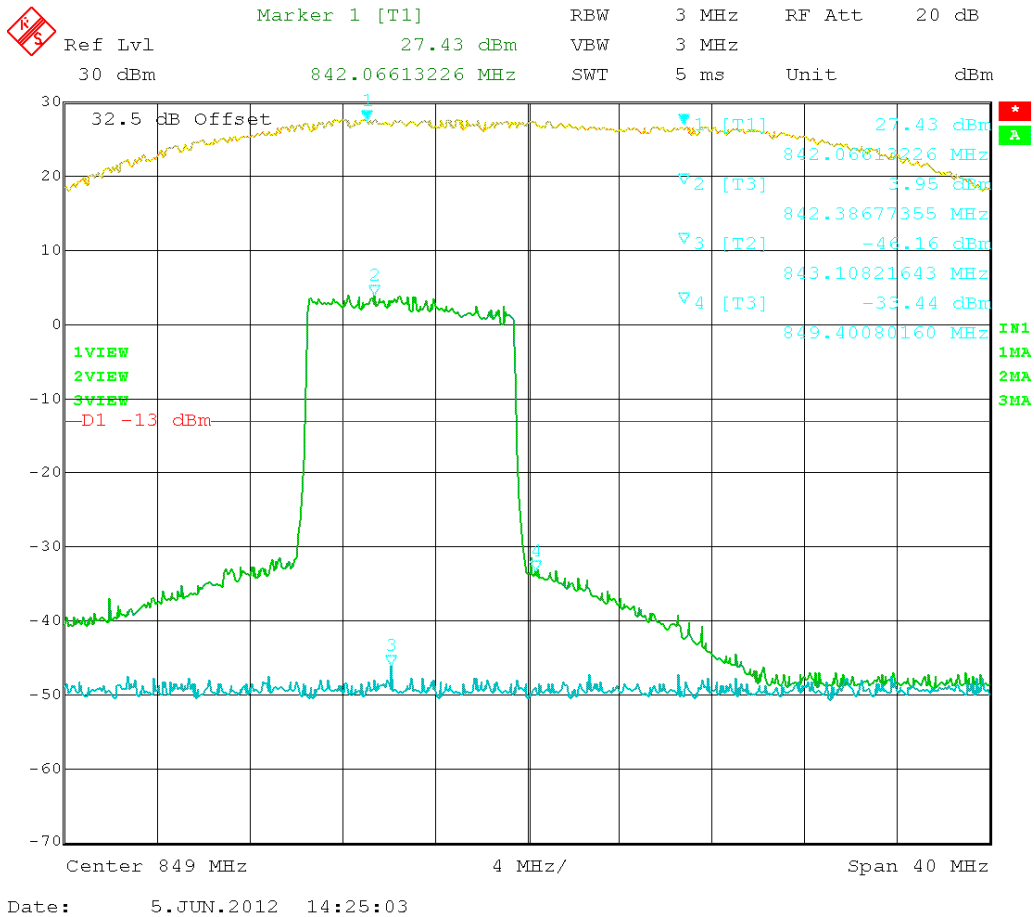

Figure 30: LTE – In vs. Out 844.00 MHz

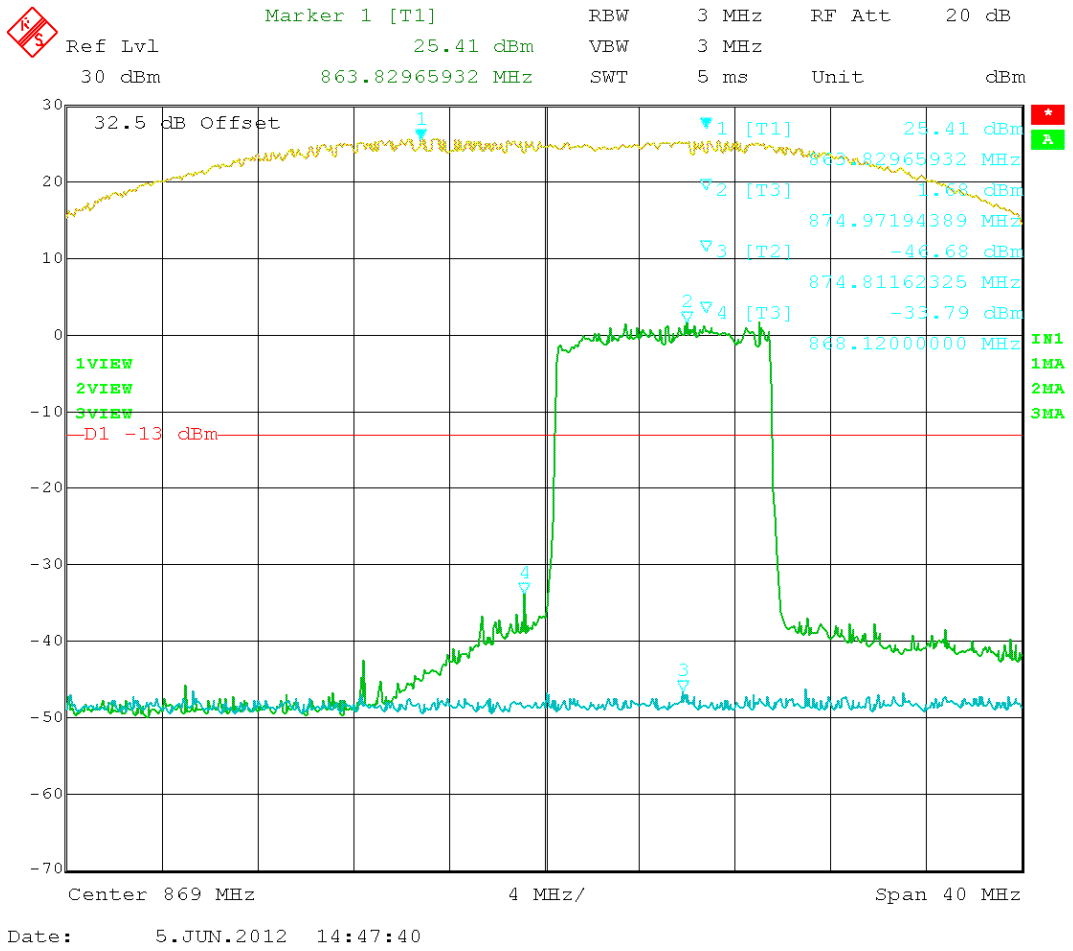

Figure 31: LTE – In vs. Out 874.00 MHz

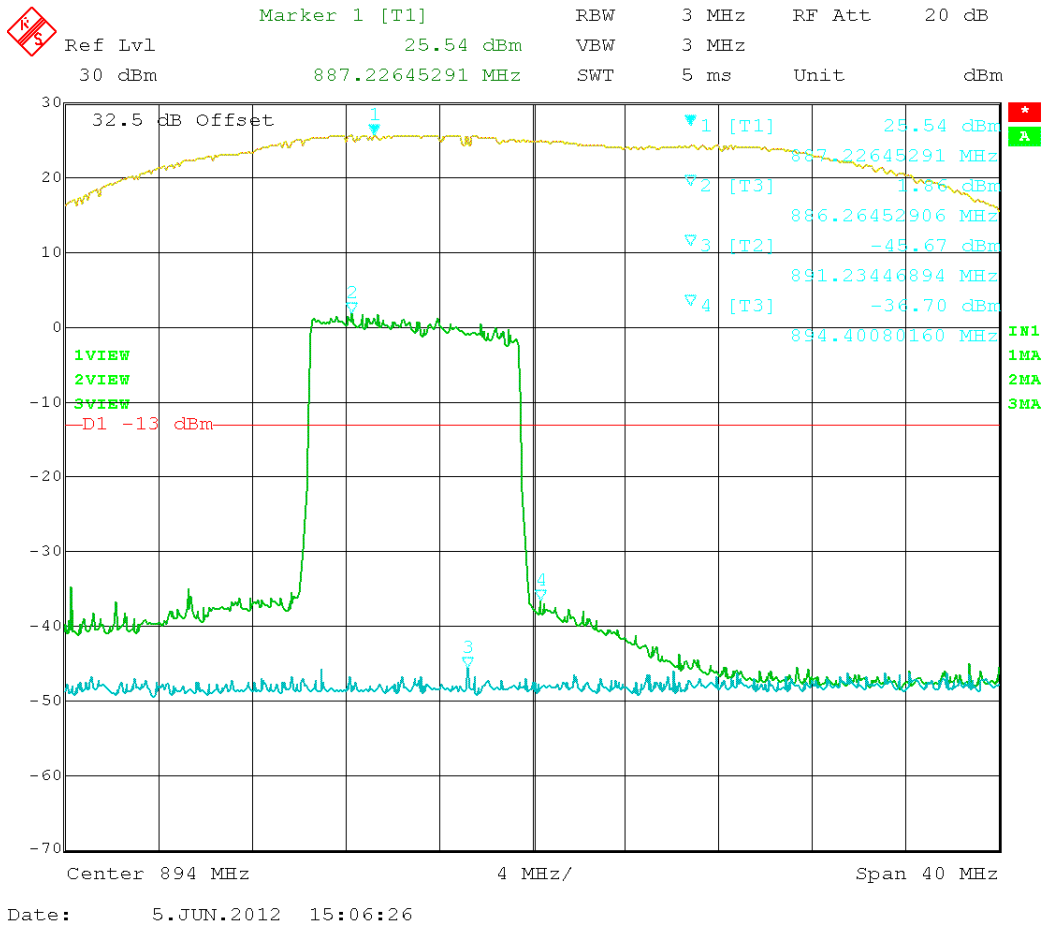

Figure 32: LYE – In vs. Out 889.00 MHz

Test Data Table 20 – GSM 800 – Uplink/Downlink

Channel (MHz)	Band-edge Frequency (MHz)	Amplitude level at the band-edge (dBm)	Limit (dBm)	Margin (dB)
824.2	823.98	-14.94	-13	1.94
848.8	849.02	-14.68	-13	1.68
869.2	868.98	-16.87	-13	3.87
893.8	894.02	-19.16	-13	6.16

The Reference level on the following plots was calibrated using a 3MHz RBW=VBW.

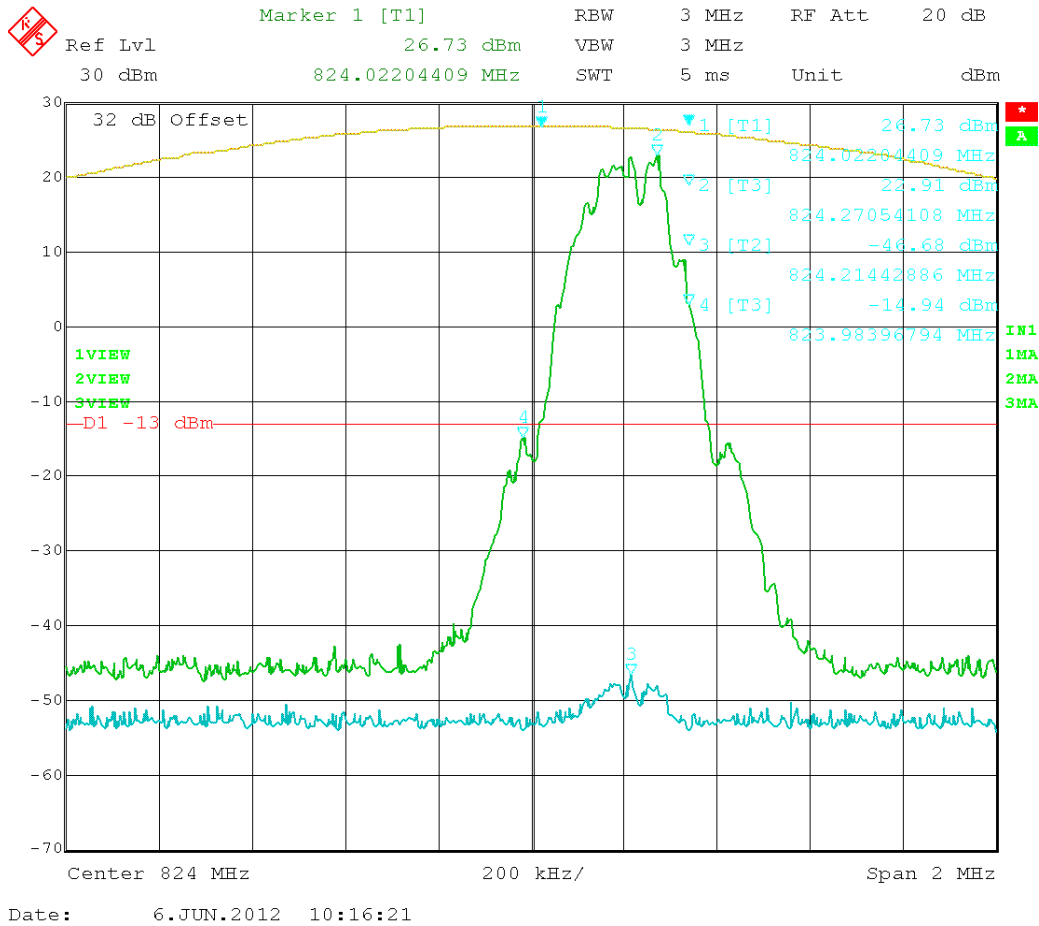

Figure 33: GSM – In vs. Out 824.2 MHz

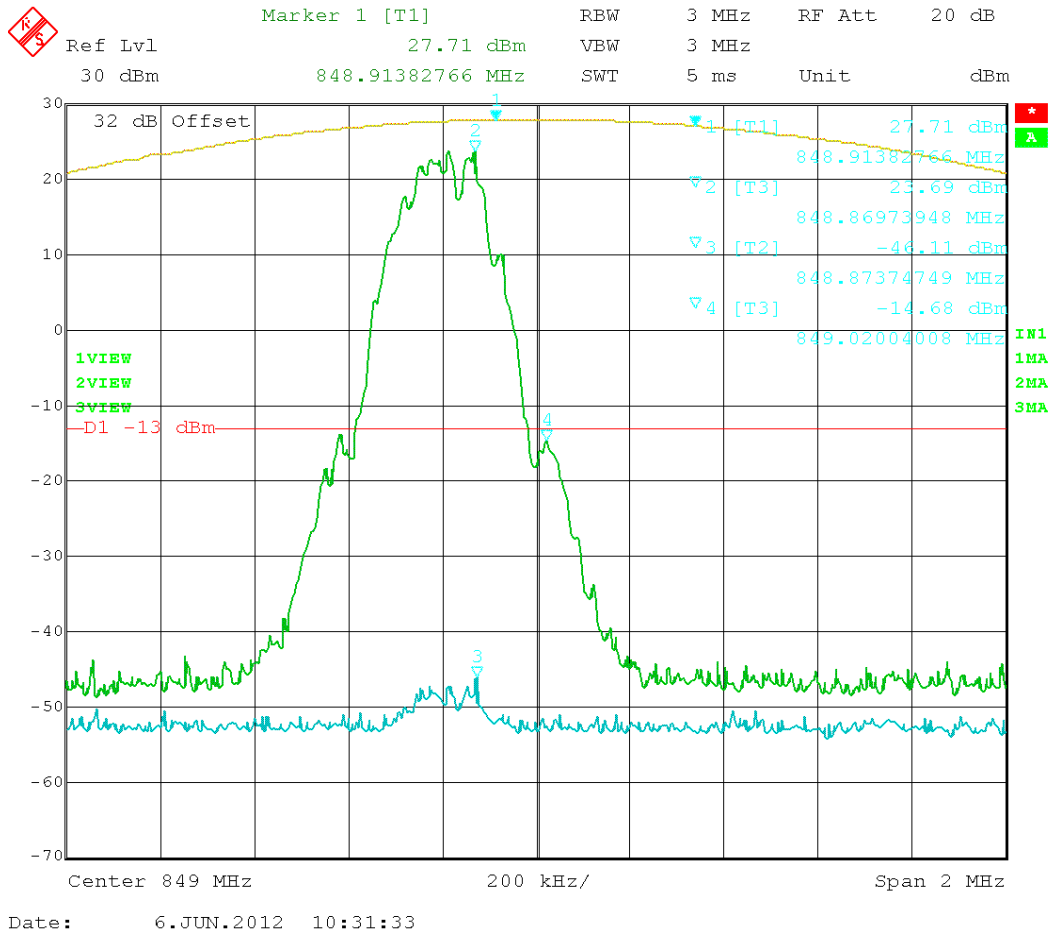

Figure 34: GSM – In vs. Out 848.8 MHz

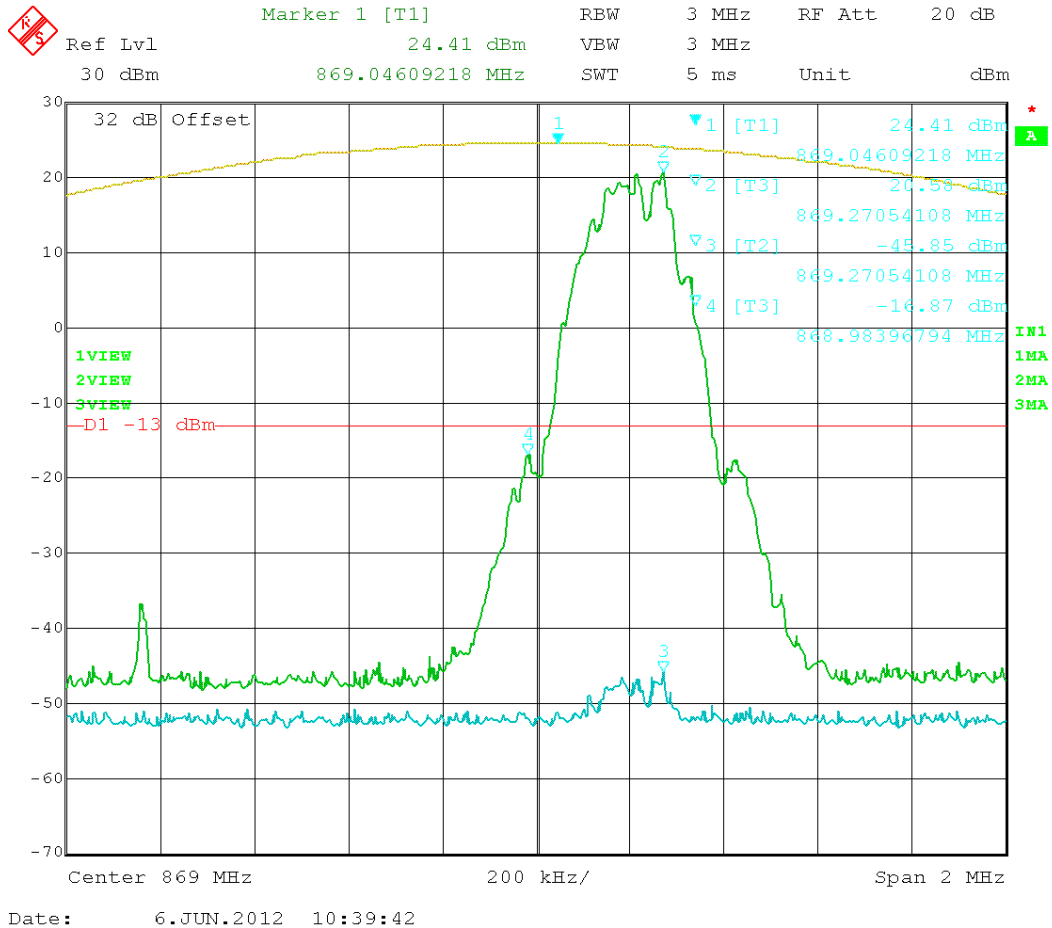

Figure 35: GSM – In vs. Out 869.2MHz

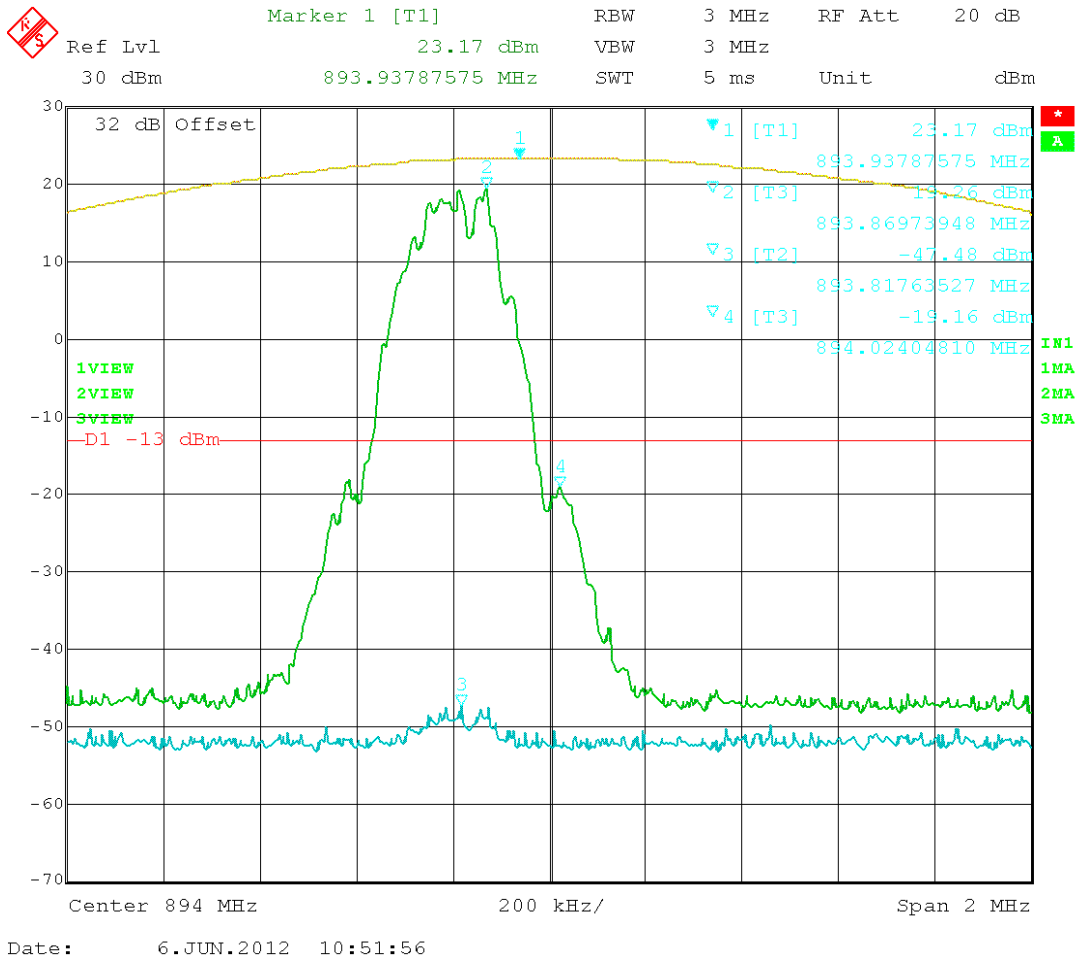

Figure 36: GSM – In vs. Out 893.8MHz

Test Data Table 21 – EDGE 800 – Uplink/Downlink

Channel (MHz)	Band-edge Frequency (MHz)	Amplitude level at the band-edge (dBm)	Limit (dBm)	Margin (dB)
824.2	823.98	-15.01	-13	2.01
848.8	849.02	-19.02	-13	6.02
869.2	868.98	-15.69	-13	2.69
893.8	894.02	-20.51	-13	7.51

The Reference level on the following plots was calibrated using a 3MHz RBW=VBW.

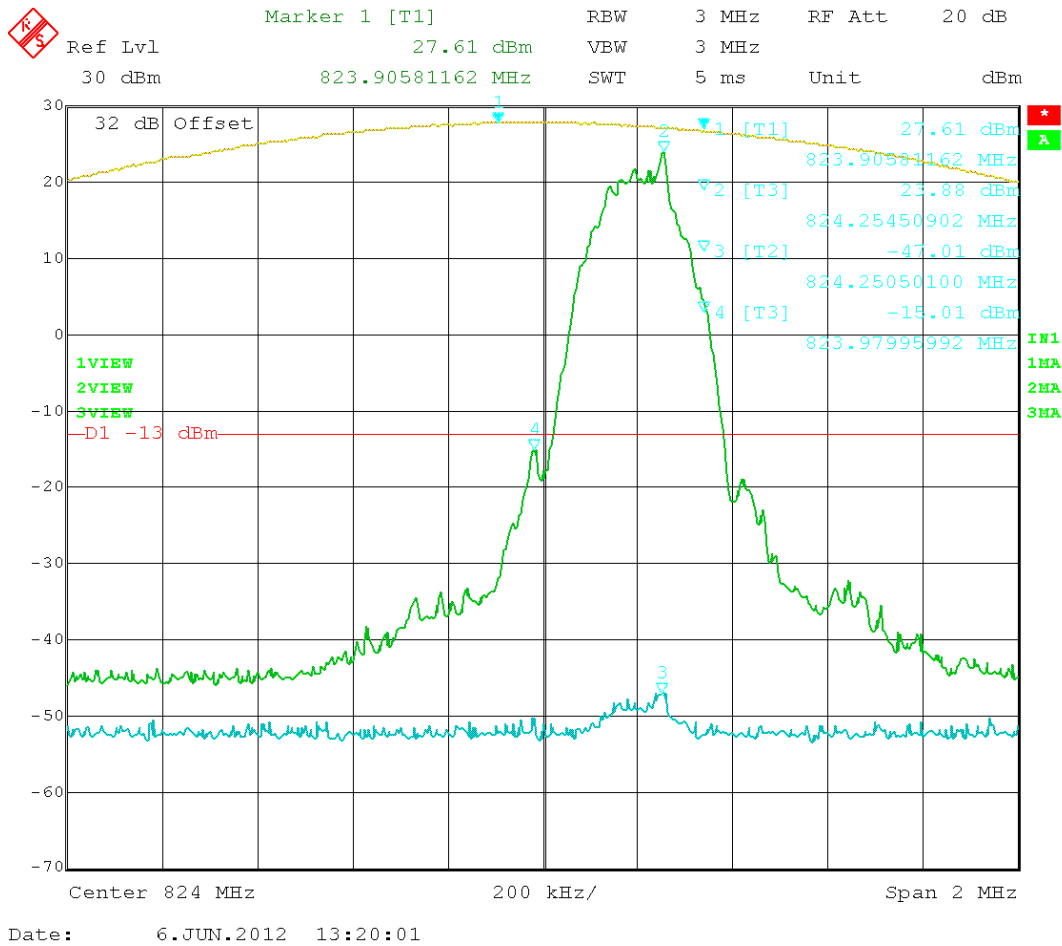

Figure 37: EDGE – In vs. Out 824.2 MHz

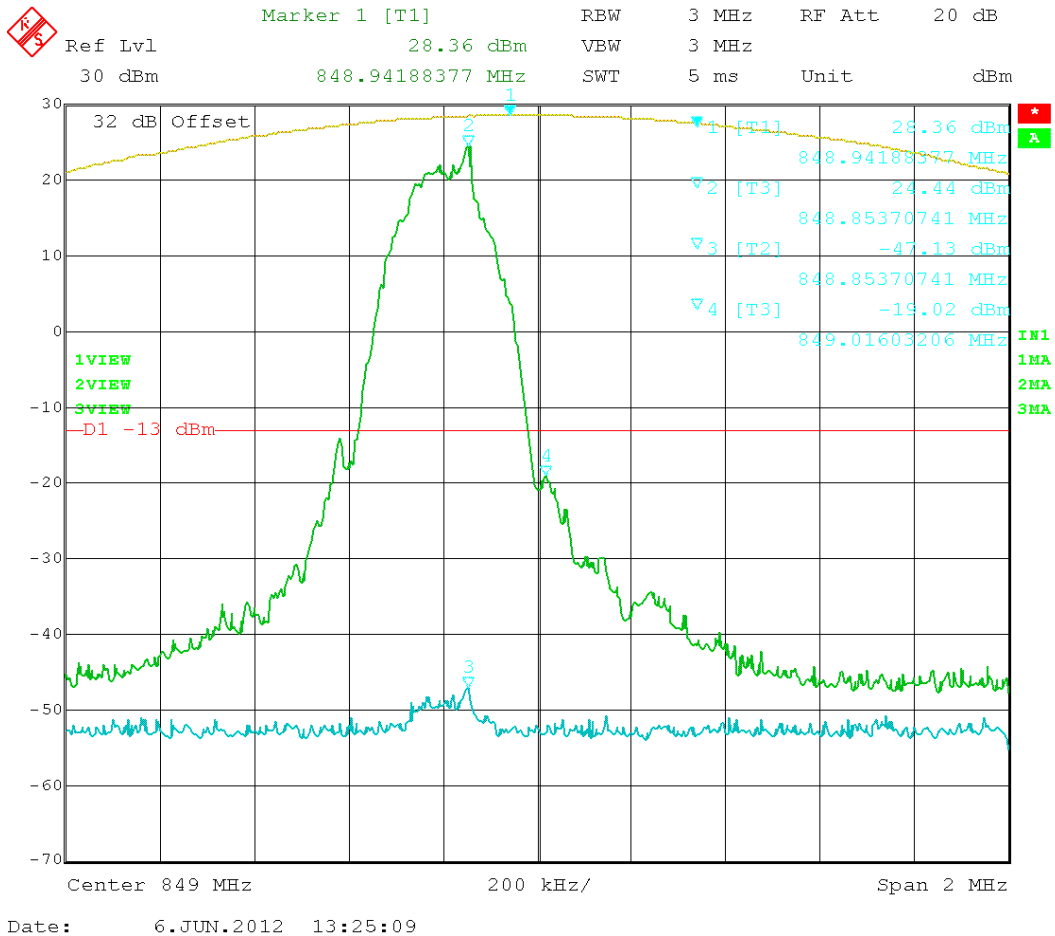

Figure 38: EDGE – In vs. Out 848.8 MHz

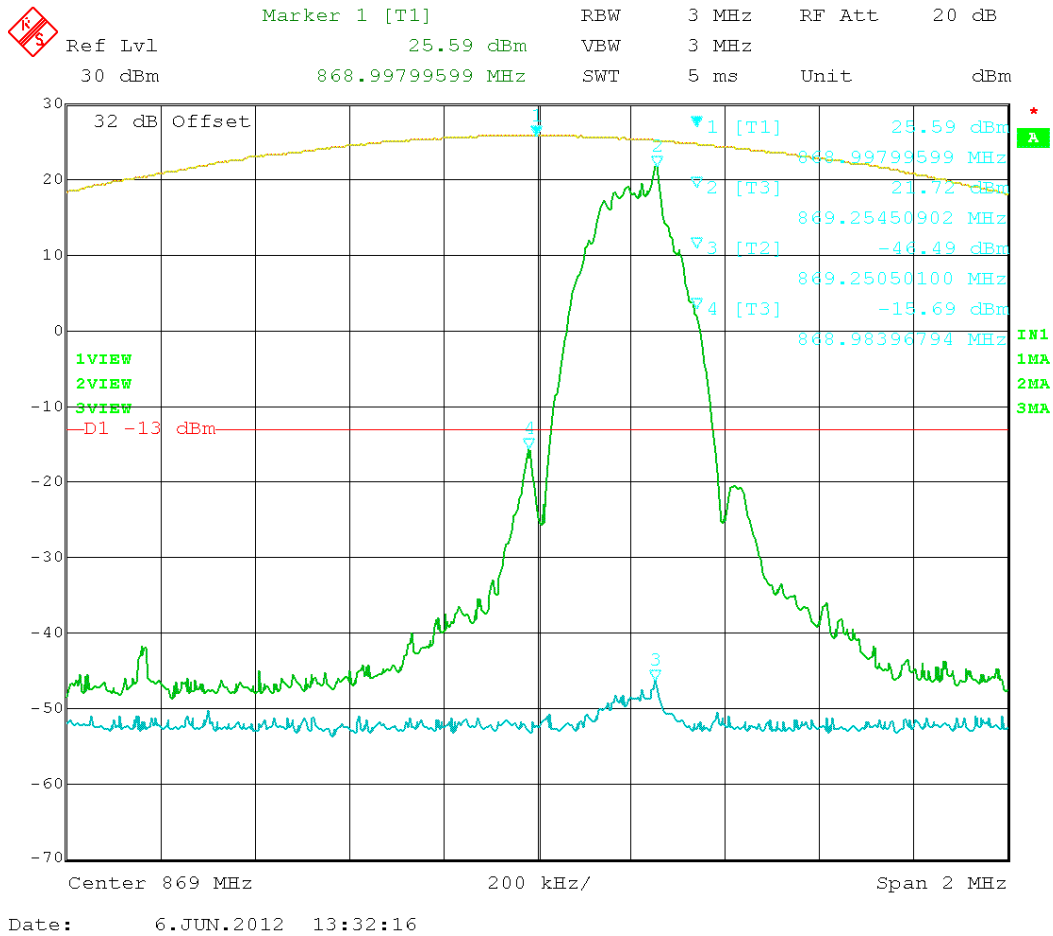

Figure 39: EDGE – In vs. Out 869.20 MHz

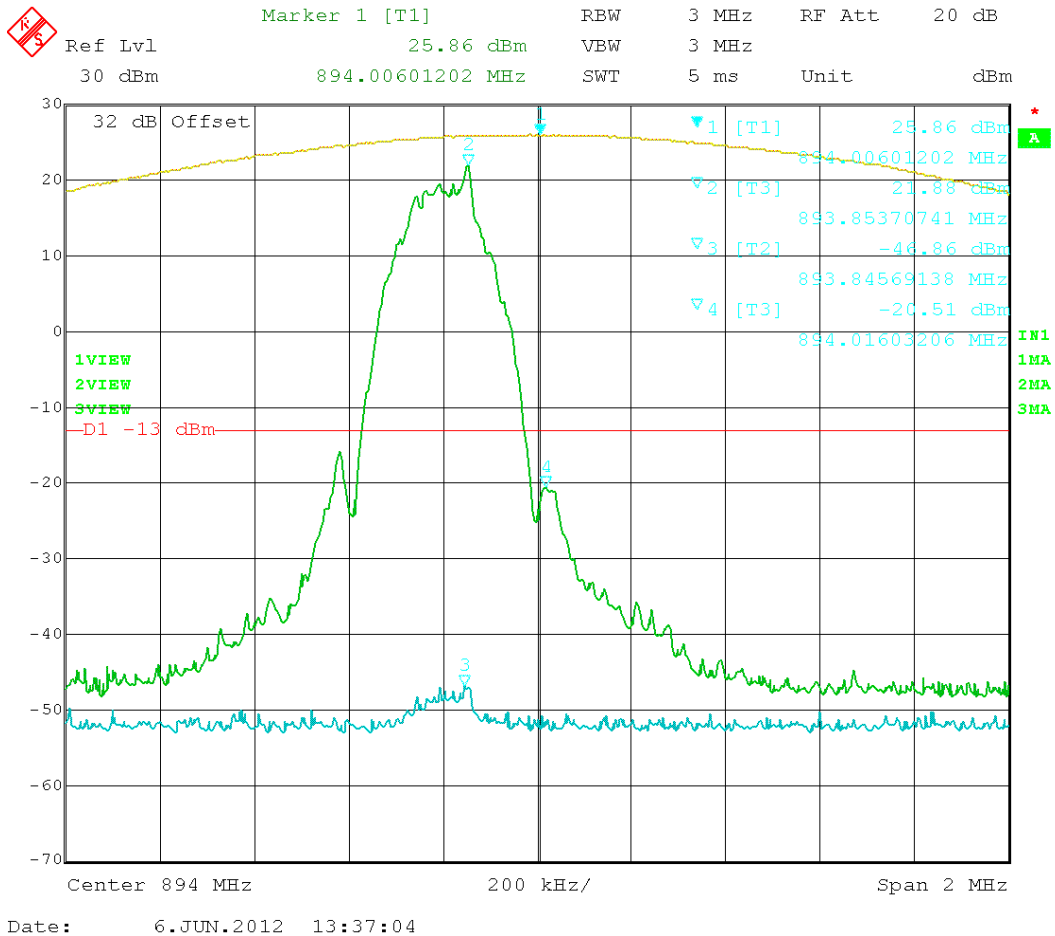

Figure 40: EDGE – In vs. Out 893.8 MHz

Test Data Table 22 – LTE 700 – Uplink/Downlink

Channel (MHz)	Band-edge Frequency (MHz)	Amplitude level at the band-edge (dBm)	Limit (dBm)	Margin (dB)
703.0	697.76	-32.52	-13	19.52
711.0	716.4	-30.05	-13	17.05
733.0	727.56	-34.40	-13	21.4
741.0	746.4	-37.38	-13	24.38

The Reference level on the following plots was calibrated using a 3MHz RBW=VBW.

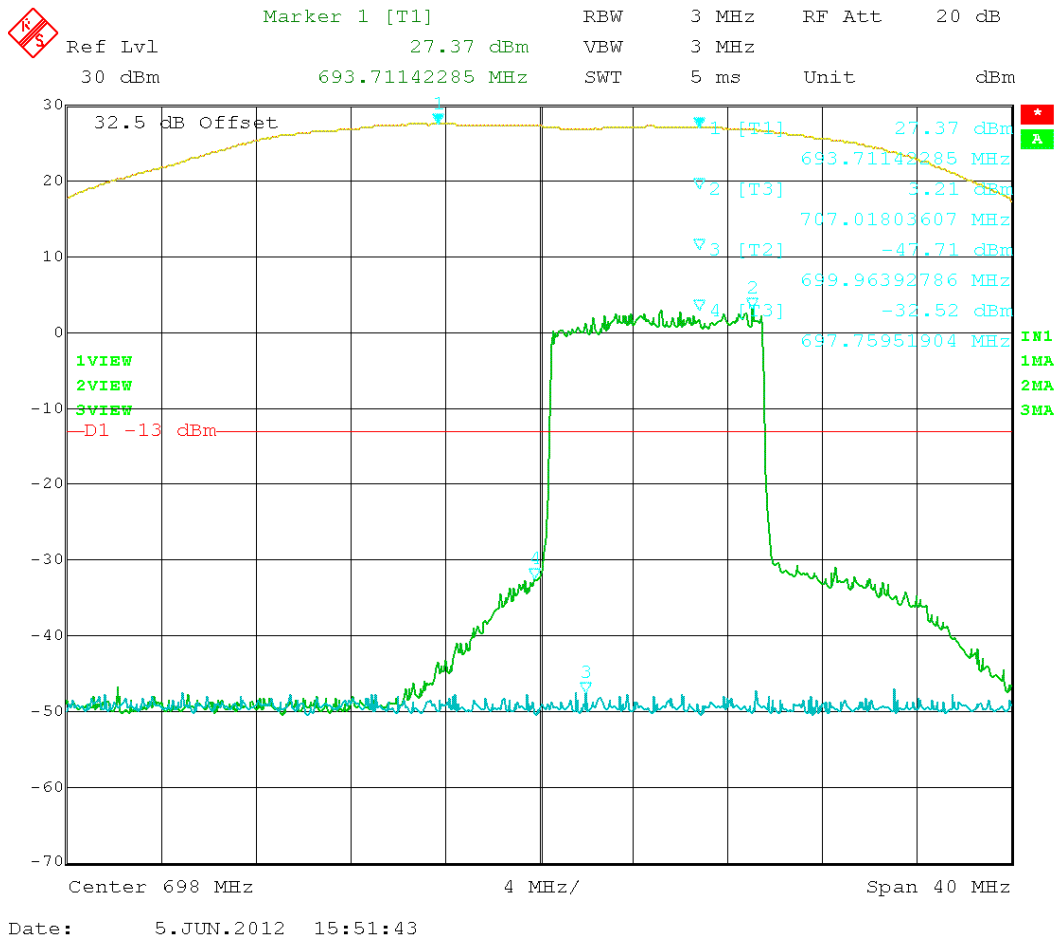

Figure 37: LTE – In vs. Out 703.0 MHz

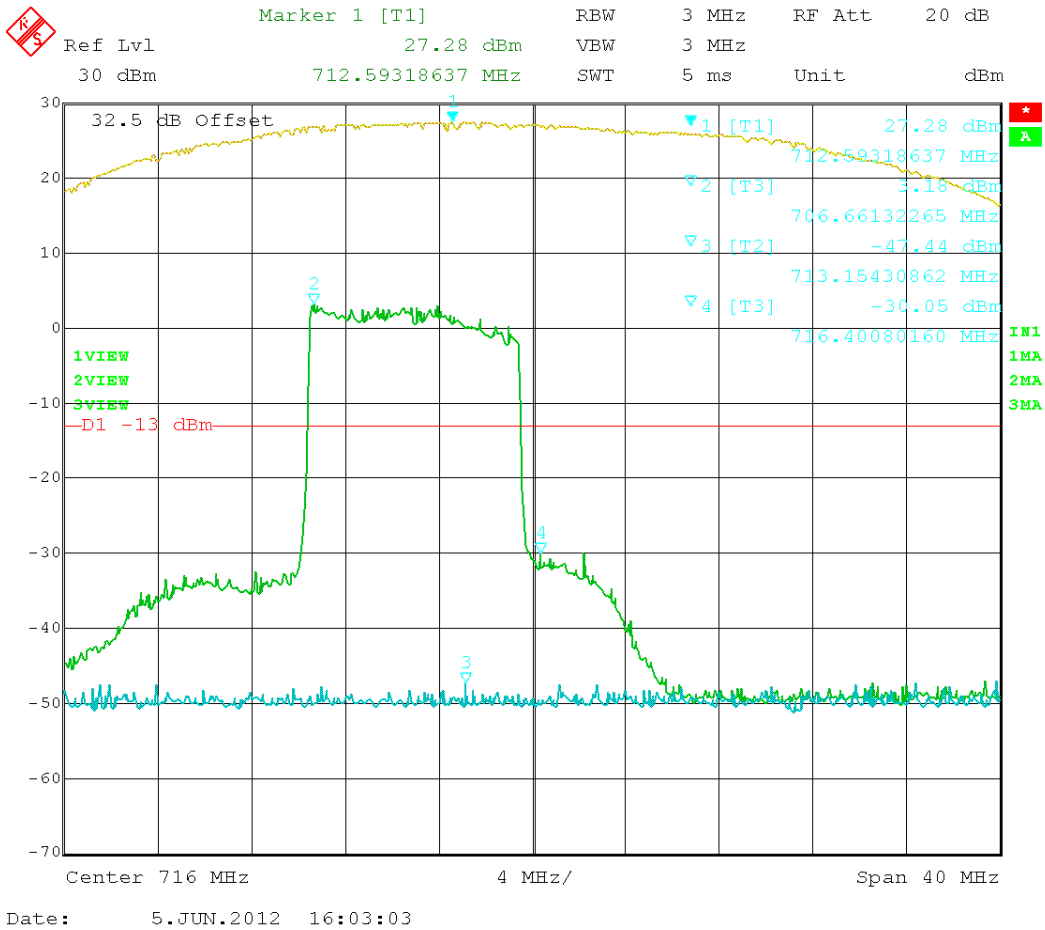

Figure 37: LTE – In vs. Out 711.0 MHz

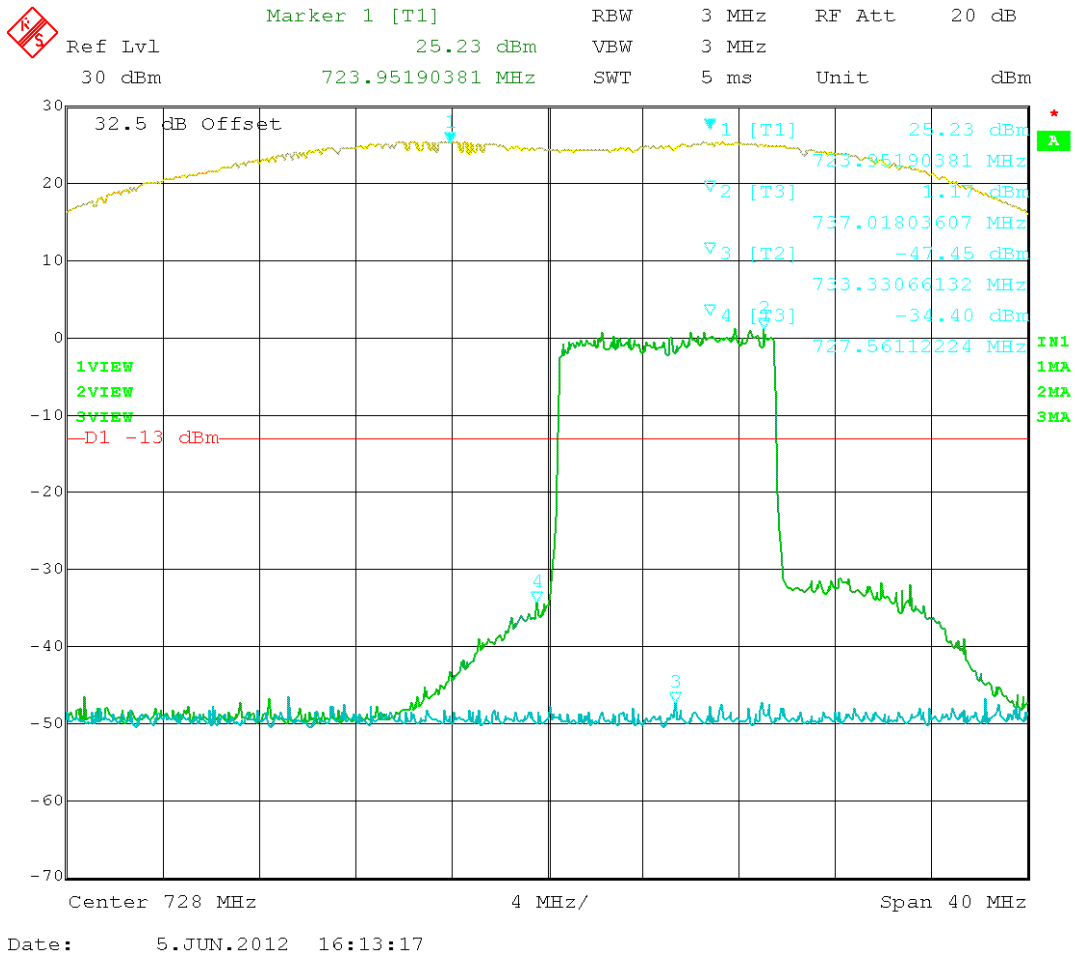

Figure 37: LTE – In vs. Out 733.0 MHz

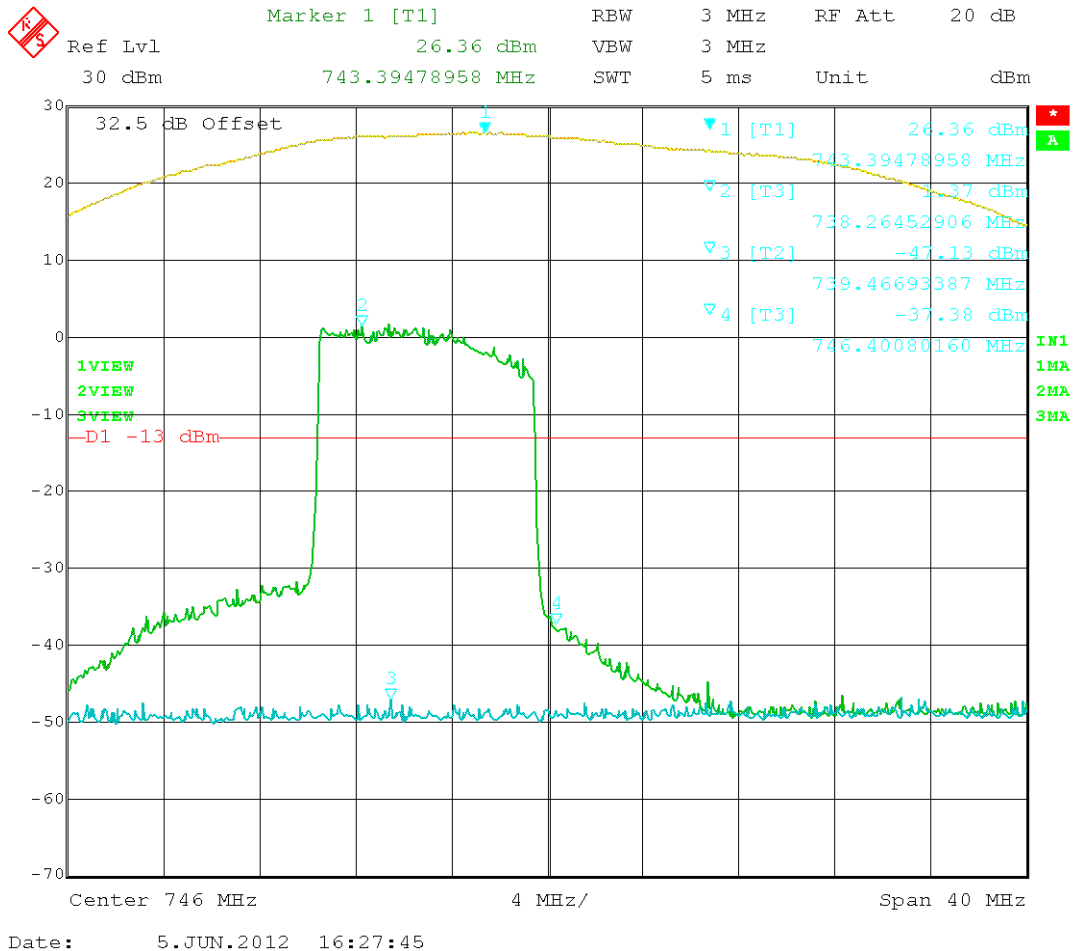

Figure 37: LTE – In vs. Out 741.0 MHz

INTERMODULATION PRODUCT SPURIOUS EMISSIONS

Rule Parts No.: Pt 2.1051

Requirements: Emissions must be $43 + 10 \log (P_o)$ dB below the mean power output of the transmitter or below the -13 dBm

All the modulation types were tested using the three tone test method. A CW signal was used instead of GSM, EDGE, and F1D modulations. EDGE and GSM provided the same test results and only GSM data are presented in this report. The input power to the amplifier was set at maximum drive level by combining the three tones. The three tones were chosen in such a way (1) the third order intermodulation product frequencies are located within the pass band of the DUT and (2) they produce the worst-case emissions out of band.

Test Data: The DUT appears to meet the requirements.

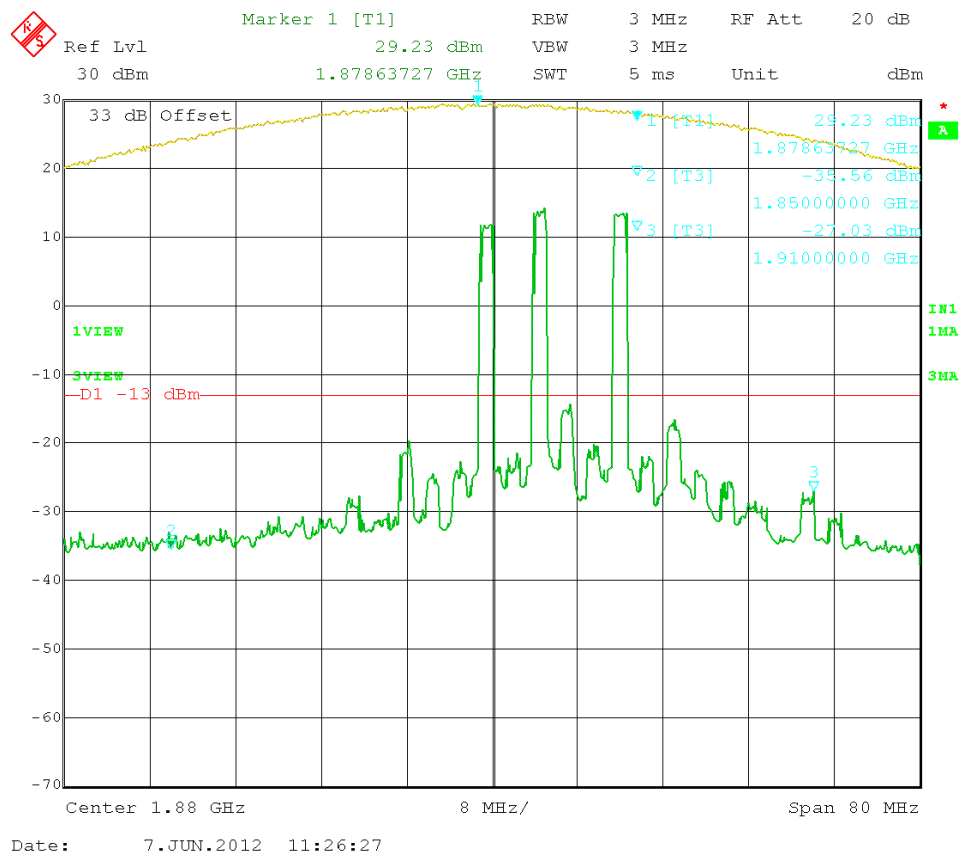

Figure 45: CDMA 3 tones intermodulation - (1850 – 1910) MHz.

Applicant: WILSON ELECTRONICS, INC.
 FCC ID: PWO275370
 Report: W\WILSON_PWO\1095AUT12\1095AUT12TestReport.doc

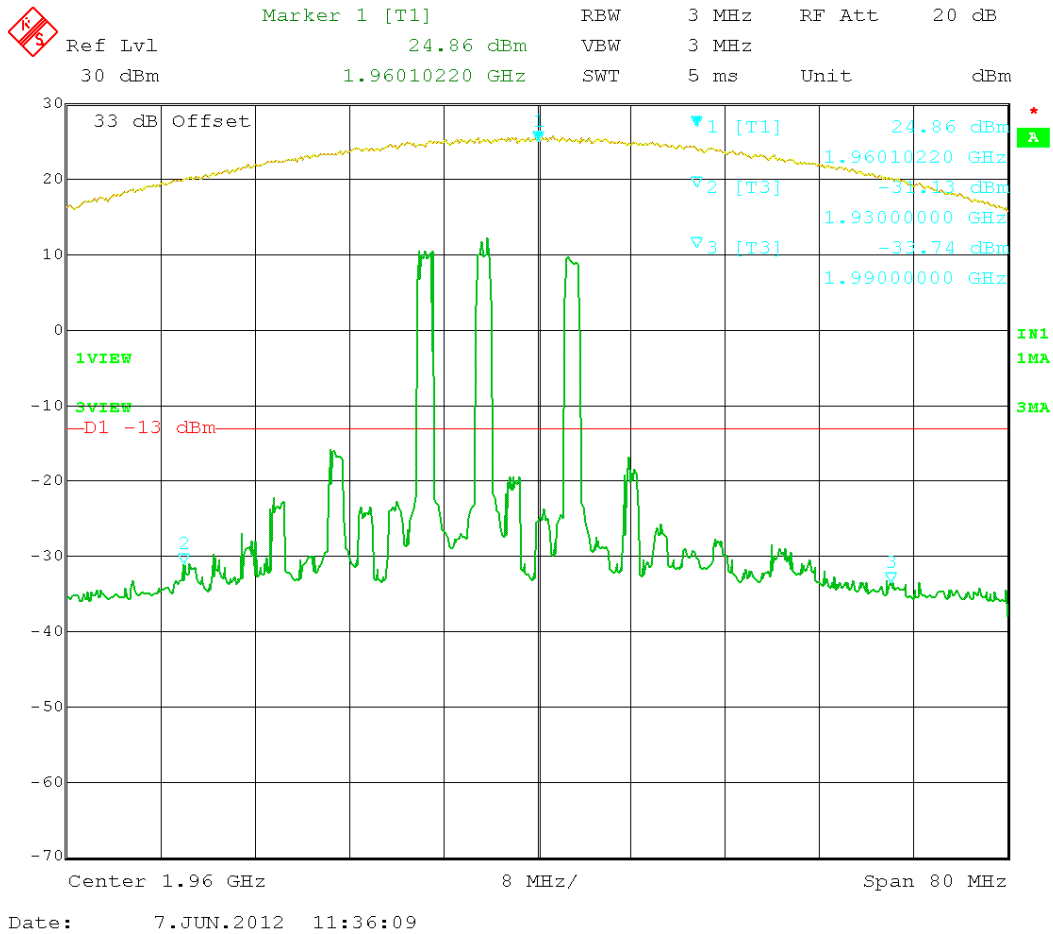

Figure 46: CDMA 3 tones intermodulation - (1930 – 1990) MHz.

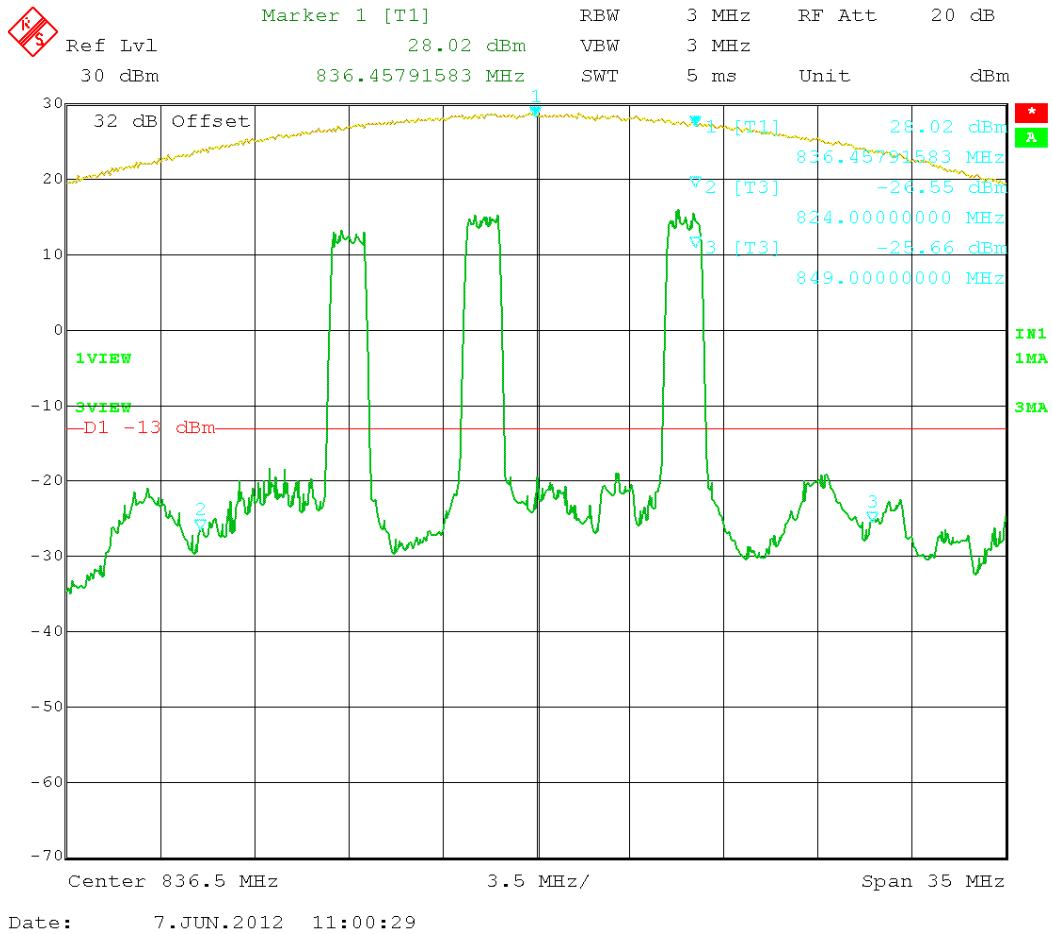

Figure 47: CDMA 3 tones intermodulation – (824 – 849) MHz.

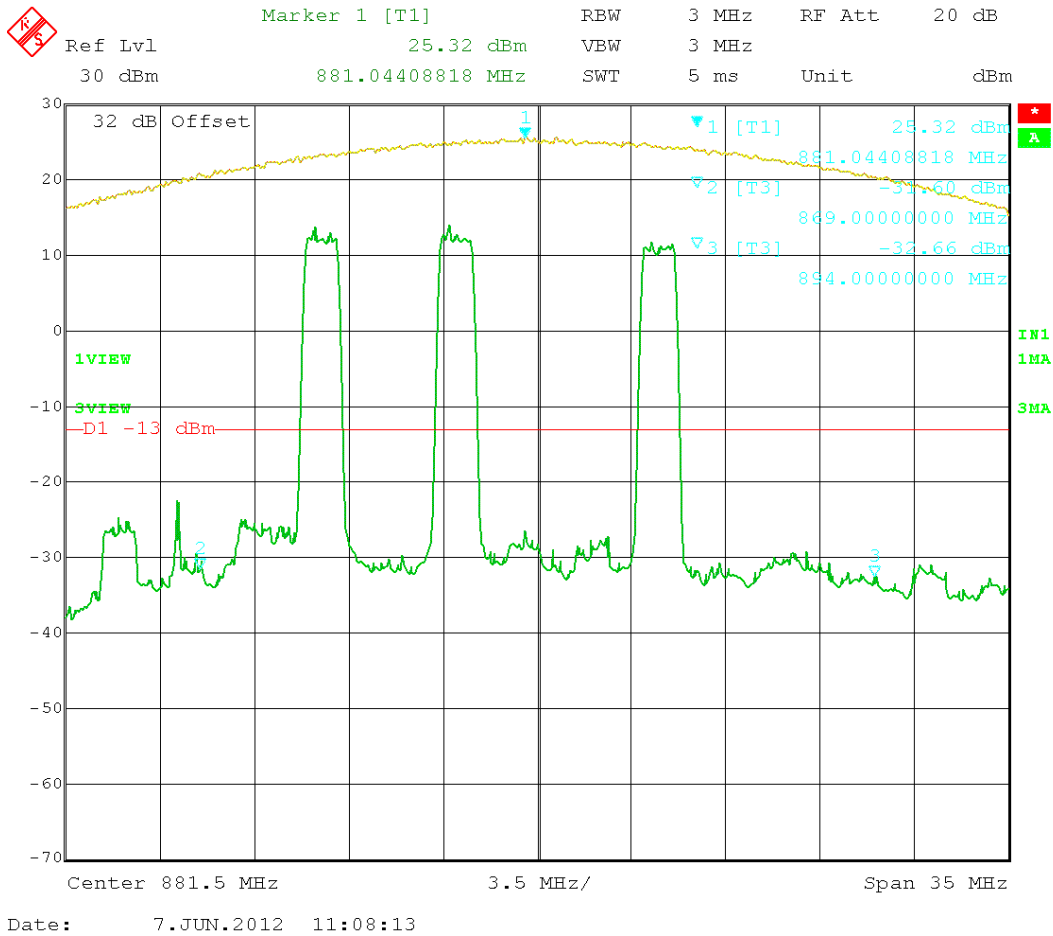

Figure 48: CDMA 3 tones intermodulation - (869 – 894) MHz.

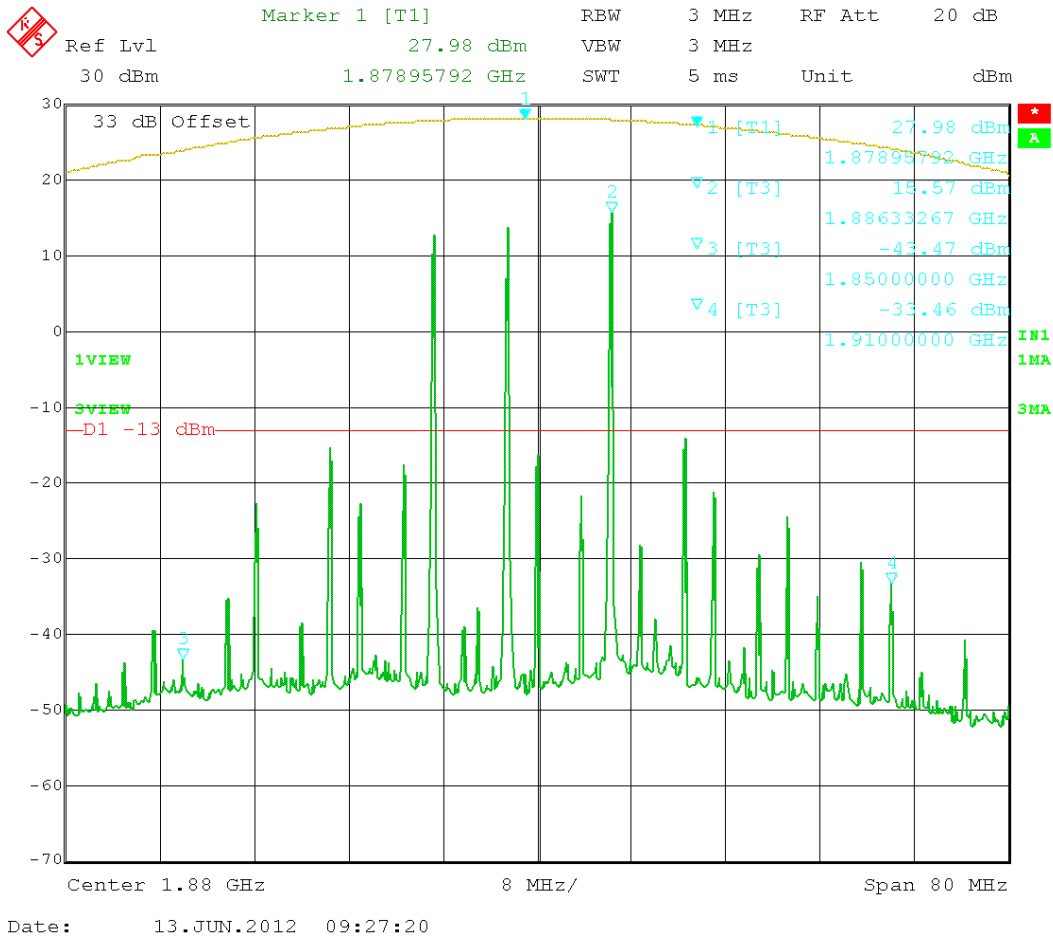

Figure 49: GSM 3 tones intermodulation - (1850 – 1910) MHz

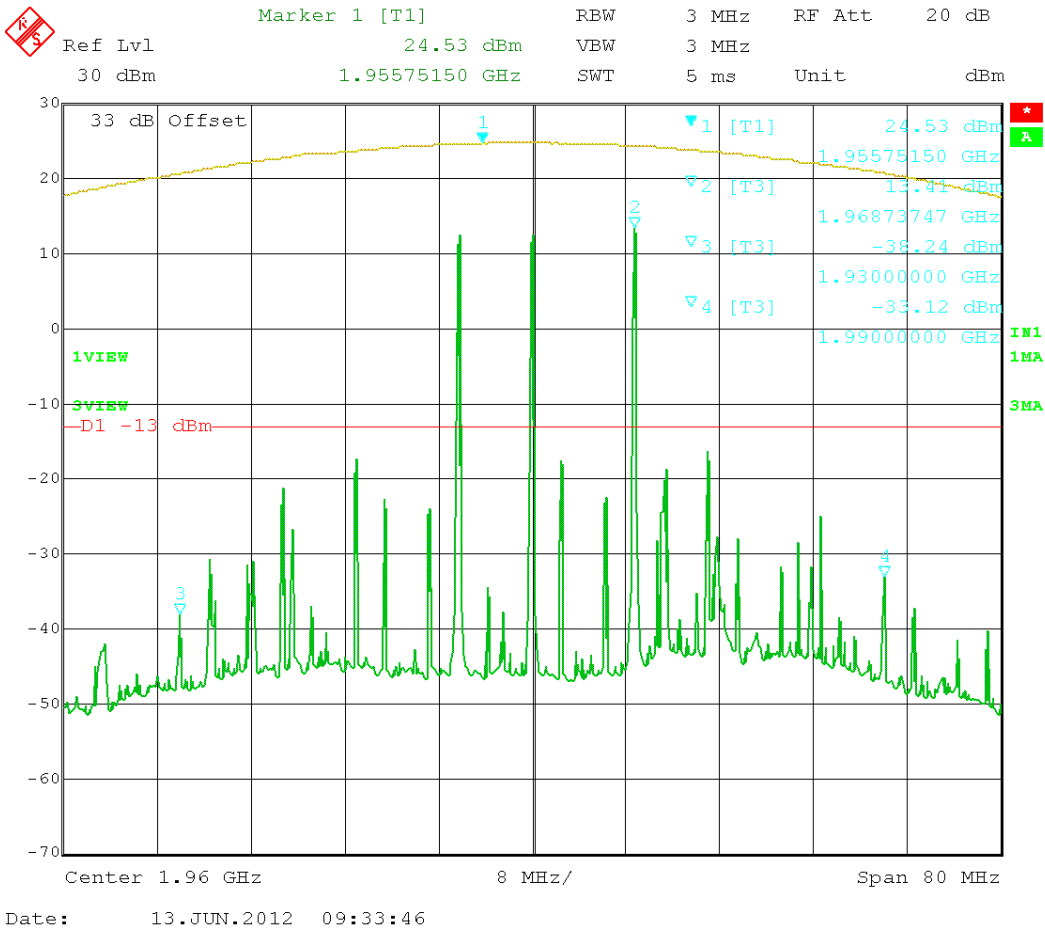

Figure 50: GSM 3 tones intermodulation - (1930 – 1990) MHz

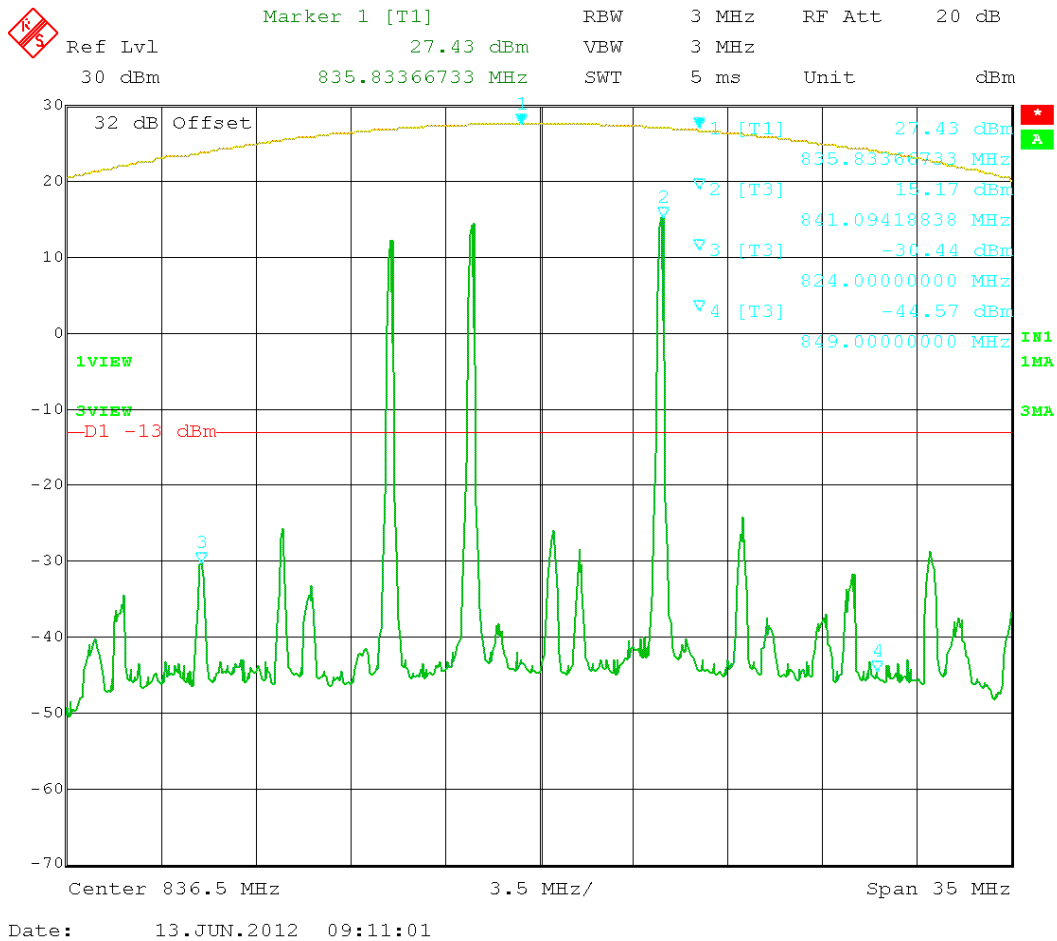

Figure 51: GSM 3 tones intermodulation - (824 – 849) MHz

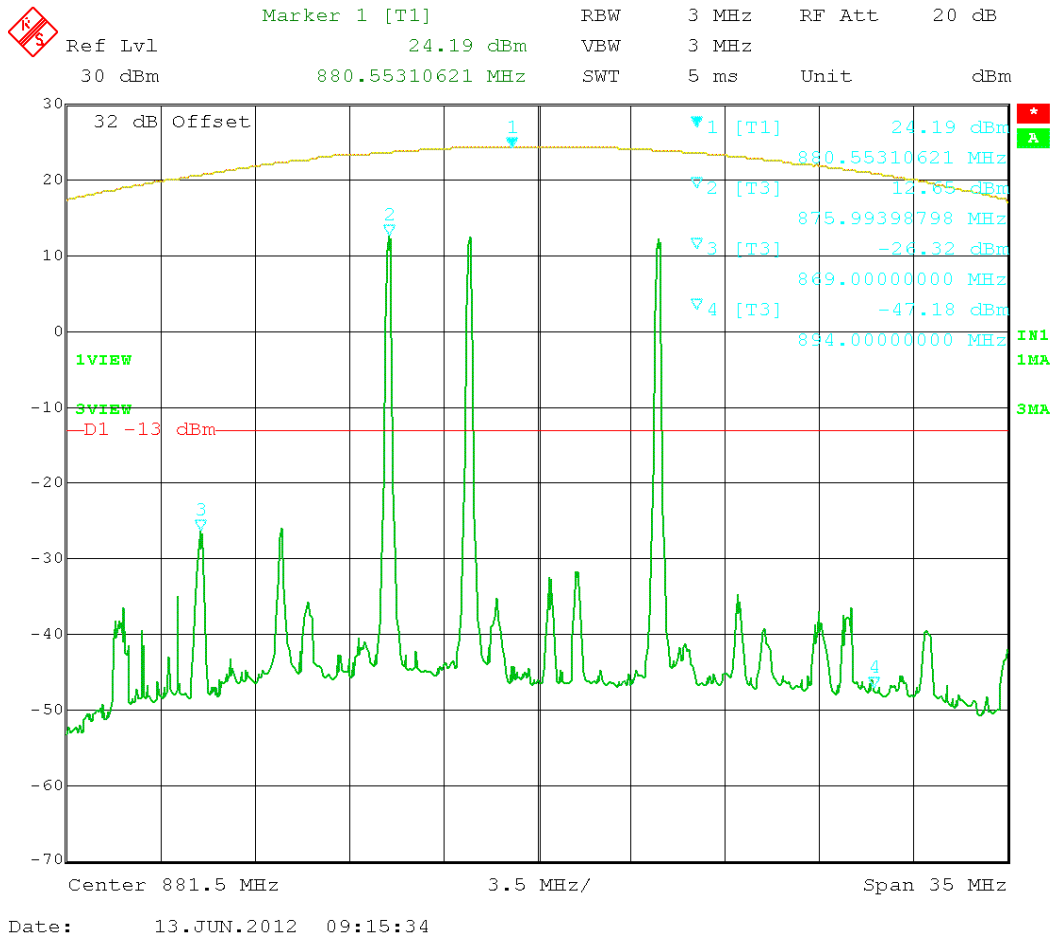

Figure 52: GSM 3 tones intermodulation - (869 – 894) MHz

SPURIOUS EMISSIONS AT ANTENNA TERMINALS

Rule Parts No.: Pt 2.1051

Requirements: Emissions must be $43 + 10\log(P_o)$ dB below the mean power output of the transmitter:

$$1850 - 1910 \text{ MHz: } 43 + 10\log(1.0) = 43.0 \text{ dBc}$$

$$1930 - 1990: 43 + 10\log(0.30) = 38.0 \text{ dBc}$$

Test Result: The DUT appears to meet the requirements.

Test Data Table 23 – Conducted Emissions – CDMA 1900 – Uplink

Emission Frequency MHz	dB Below Carrier (dBc)	Emission Frequency MHz	dB Below Carrier (dBc)	Emission Frequency MHz	dB Below Carrier (dBc)
1851.25		1880.00		1908.75	
3702.50	73.5	3760.00	69.3	3817.50	72.4
5553.75	81.9	5640.00	83.3	5726.25	81.4
7405.00	83.4	7520.00	84.3	7635.00	82.2
9256.25	83.0	9400.00	85.7	9543.75	82.9
11107.50	NF	11280.00	NF	11452.50	NF
12958.75	NF	13160.00	NF	13361.25	NF
14810.00	NF	15040.00	NF	15270.00	NF
16661.25	NF	16920.00	NF	17178.75	NF
18512.50	NF	18800.00	NF	19087.50	NF

Test Data Table 24 – Conducted Emissions – CDMA 1900 – Downlink

Emission Frequency MHz	dB Below Carrier (dBc)	Emission Frequency MHz	dB Below Carrier (dBc)	Emission Frequency MHz	DB Below Carrier (dBc)
1931.25		1960.00		1988.75	
3862.50	62.1	3920.00	64.5	3977.50	71.9
5793.75	76.7	5880.00	78.2	5966.25	77.5
7725.00	78.2	7840.00	79.1	7955.00	78.3
9656.25	77.5	9800.00	79.5	9943.75	78.3
11587.50	NF	11760.00	NF	11932.50	NF
13518.75	NF	13720.00	NF	13921.25	NF
15450.00	NF	15680.00	NF	15910.00	NF
17381.25	NF	17640.00	NF	17898.75	NF
19312.50	NF	19600.00	NF	19887.50	NF

Applicant: WILSON ELECTRONICS, INC.
 FCC ID: PWO275370
 Report: W\WILSON_PWO\1095AUT12\1095AUT12TestReport.doc

Test Data Table 25 – Conducted Emissions – GSM 1900 - Uplink

Emission Frequency MHz	dB Below Carrier (dBc)	Emission Frequency MHz	dB Below Carrier (dBc)	Emission Frequency MHz	dB Below Carrier (dBc)
1850.20		1880.00		1909.80	
3700.40	76.0	3760.00	69.0	3819.60	72.1
5550.60	86.3	5640.00	86.4	5729.40	84.1
7400.80	87.0	7520.00	87.3	7639.20	85.7
9251.00	88.2	9400.00	91.0	9549.00	85.8
11101.20	NF	11280.00	NF	11458.80	NF
12951.40	NF	13160.00	NF	13368.60	NF
14801.60	NF	15040.00	NF	15278.40	NF
16651.80	NF	16920.00	NF	17188.20	NF
18502.00	NF	18800.00	NF	19098.00	NF

Test Data Table 26 – Conducted Emissions – GSM 1900 - Downlink

Emission Frequency MHz	dB Below Carrier (dBc)	Emission Frequency MHz	dB Below Carrier (dBc)	Emission Frequency MHz	dB Below Carrier (dBc)
1930.20		1960.00		1989.80	
3860.40	64.6	3920.00	67.6	3979.60	72.6
5790.60	83.9	5880.00	85.0	5969.40	83.5
7720.80	84.5	7840.00	85.4	7959.20	84.9
9651.00	85.1	9800.00	85.7	9949.00	84.0
11581.20	NF	11760.00	NF	11938.80	NF
13511.40	NF	13720.00	NF	13928.60	NF
15441.60	NF	15680.00	NF	15918.40	NF
17371.80	NF	17640.00	NF	17908.20	NF
19302.00	NF	19600.00	NF	19898.00	NF

Test Data Table 27 – Conducted Emissions – CDMA 800 - Uplink

Emission Frequency MHz	dB Below Carrier (dBc)	Emission Frequency MHz	dB Below Carrier (dBc)	Emission Frequency MHz	dB Below Carrier (dBc)
825.25		836.50		847.75	
1650.50	81.9	1673.00	81.7	1695.50	80.3
2475.75	65.7	2509.50	64.1	2543.25	62.2
3301.00	74.1	3346.00	70.7	3391.00	68.6
4126.25	82.7	4182.50	86.0	4238.75	84.6
4951.50	NF	5019.00	NF	5086.50	NF
5776.75	NF	5855.50	NF	5934.25	NF
6602.00	NF	6692.00	NF	6782.00	NF
7427.25	NF	7528.50	NF	7629.75	NF
8252.50	NF	8365.00	NF	8477.50	NF

Test Data Table 28 – Conducted Emissions – CDMA 800 - Downlink

Emission Frequency MHz	dB Below Carrier (dBc)	Emission Frequency MHz	dB Below Carrier (dBc)	Emission Frequency MHz	dB Below Carrier (dBc)
870.25		881.50		892.75	
1740.50	65.7	1763.00	65.5	1785.50	63.0
2610.75	68.0	2644.50	69.7	2678.25	67.9
3481.00	63.6	3526.00	68.0	3571.00	64.0
4351.25	68.2	4407.50	70.0	4463.75	67.9
5221.50	NF	5289.00	NF	5356.50	NF
6091.75	NF	6170.50	NF	6249.25	NF
6962.00	NF	7052.00	NF	7142.00	NF
7832.25	NF	7933.50	NF	8034.75	NF
8702.50	NF	8815.00	NF	8927.50	NF

Test Data Table 29 – Conducted Emissions – GSM 800 – Uplink

Emission Frequency MHz	dB Below Carrier (dBc)	Emission Frequency MHz	dB Below Carrier (dBc)	Emission Frequency MHz	dB Below Carrier (dBc)
824.20		836.50		848.80	
1648.40	82.6	1673.00	83.7	1697.60	83.5
2472.60	66.8	2509.50	66.0	2546.40	63.9
3296.80	73.5	3346.00	70.8	3395.20	69.8
4121.00	84.5	4182.50	87.7	4244.00	87.8
4945.20	NF	5019.00	NF	5092.80	NF
5769.40	NF	5855.50	NF	5941.60	NF
6593.60	NF	6692.00	NF	6790.40	NF
7417.80	NF	7528.50	NF	7639.20	NF
8242.00	NF	8365.00	NF	8488.00	NF

Test Data Table 30 – Conducted Emissions – GSM 800 - Downlink

Emission Frequency MHz	dB Below Carrier (dBc)	Emission Frequency MHz	dB Below Carrier (dBc)	Emission Frequency MHz	dB Below Carrier (dBc)
869.20		881.50		893.80	
1738.40	79.4	1763.00	75.9	1787.60	77.1
2607.60	86.3	2644.50	85.6	2681.40	83.0
3476.80	76.9	3526.00	82.8	3575.20	78.2
4346.00	84.7	4407.50	87.4	4469.00	84.3
5215.20	85.4	5289.00	86.8	5362.80	84.5
6084.40	NF	6170.50	NF	6256.60	NF
6953.60	NF	7052.00	NF	7150.40	NF
7822.80	NF	7933.50	NF	8044.20	NF
8692.00	NF	8815.00	NF	8938.00	NF

FIELD STRENGTH OF SPURIOUS EMISSIONS

Rule Parts No.: Pt 2.1053

Requirements: Emissions must be 43+10log(Po) dB below the mean power output of the amplifier:

$$43 + 10\log(1.00) = 43.0 \text{ dB}$$

$$43 + 10\log(0.30) = 38.0 \text{ dB}$$

Test Result: The test data indicates the DUT meets the requirements

Test Data Table 31 – Radiated Emissions – CW (1900 MHz) – Uplink /Downlink

Emission Frequency MHz	Ant. Polarity	dB Below Carrier (dBc)	Emission Frequency MHz	Ant. Polarity	dB Below Carrier (dBc)
1880.00	0	0	1960.00	0	0
3760.00	H	81.9	3920.00	H	64.1
5640.00	H	82.4	5880.00	H	74.3
7520.00	H	81.6	7840.00	H	73.3
9400.00	H	78.0	9800.00	H	64.0
11280.00	H/V	NF	11760.00	H/V	NF
13160.00	H/V	NF	13720.00	H/V	NF
15040.00	H/V	NF	15680.00	H/V	NF
16920.00	H/V	NF	17640.00	H/V	NF
18800.00	H/V	NF	19600.00	H/V	NF

Notes: *No other emissions were found up to the 10th harmonics - NOISE FLOOR

[Continued]

Test Data Table 32 – Radiated Emissions – CW (800 MHz) – Uplink /Downlink

Emission Frequency MHz	Ant. Polarity	dB Below Carrier (dBc)	Emission Frequency MHz	Ant. Polarity	dB Below Carrier (dBc)
836.50	0	0	881.50	0	0
1673.00	H	83.8	1763.00	H	81.4
2509.50	H	62.0	2644.50	H	72.8
3346.00	V	64.1	3526.00	H	70.1
4182.50	H	78.1	4407.50	H/V	NF
5019.00	H	80.1	5289.00	H/V	NF
5855.50	H/V	NF	6170.50	H/V	NF
6692.00	H/V	NF	7052.00	H/V	NF
7528.50	H/V	NF	7933.50	H/V	NF
8365.00	H/V	NF	8815.00	H/V	NF

Notes: *No other emissions were found up to the 10th harmonics - NOISE FLOOR

OUT OF BAND REJECTION: FREQUENCY RESPONSE

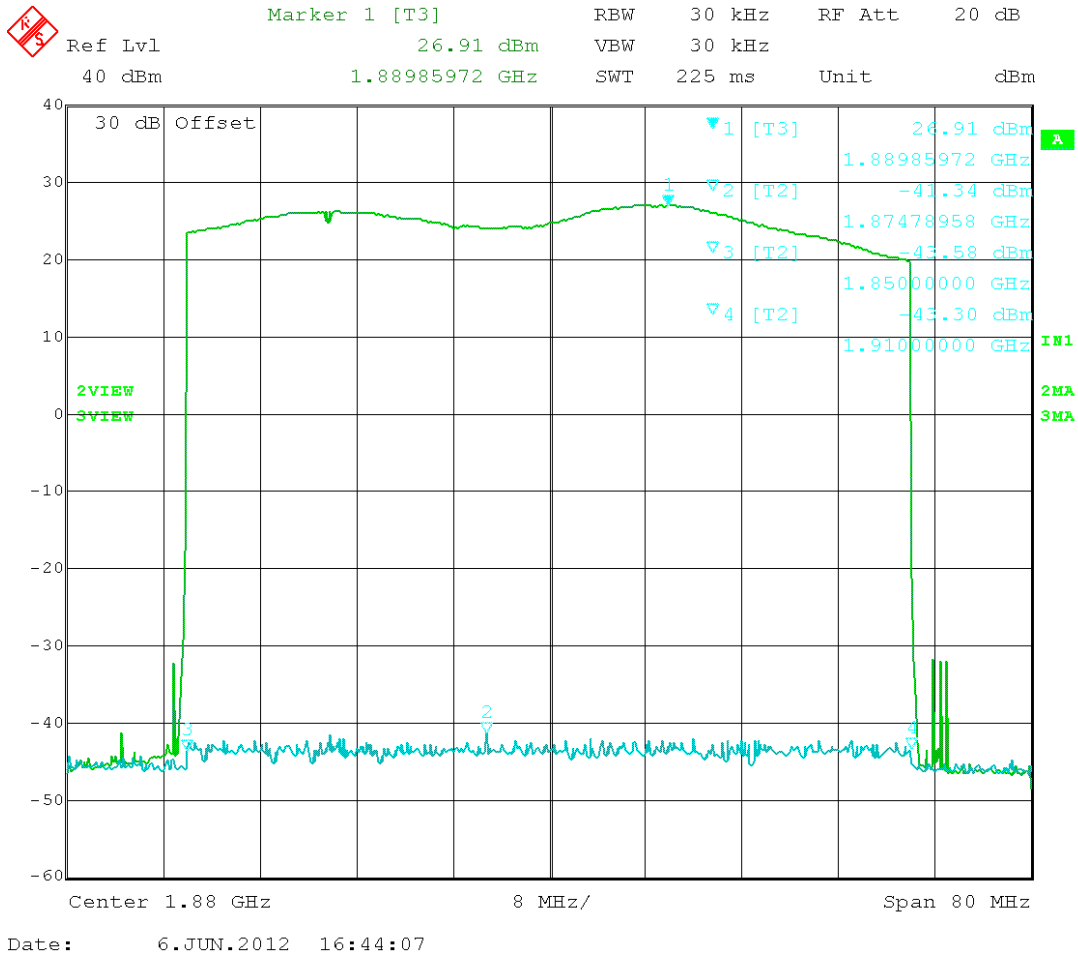

Figure 53. Frequency response (1850 – 1910) MHz band

Input	-41.34
Output	26.91
Pass Band Gain	68.25

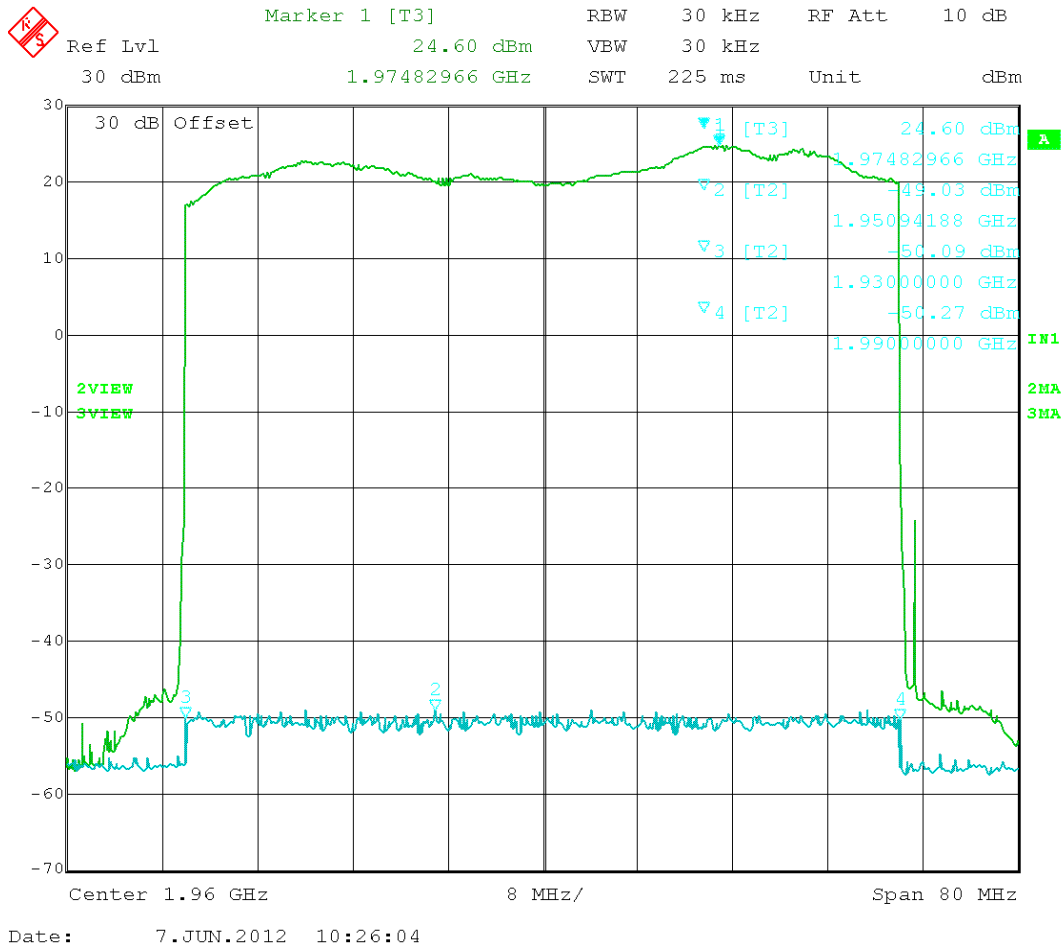

Figure 54. Frequency response (1930 – 1990) MHz band

Input	-49.03
Output	24.6
Pass Band Gain	73.63

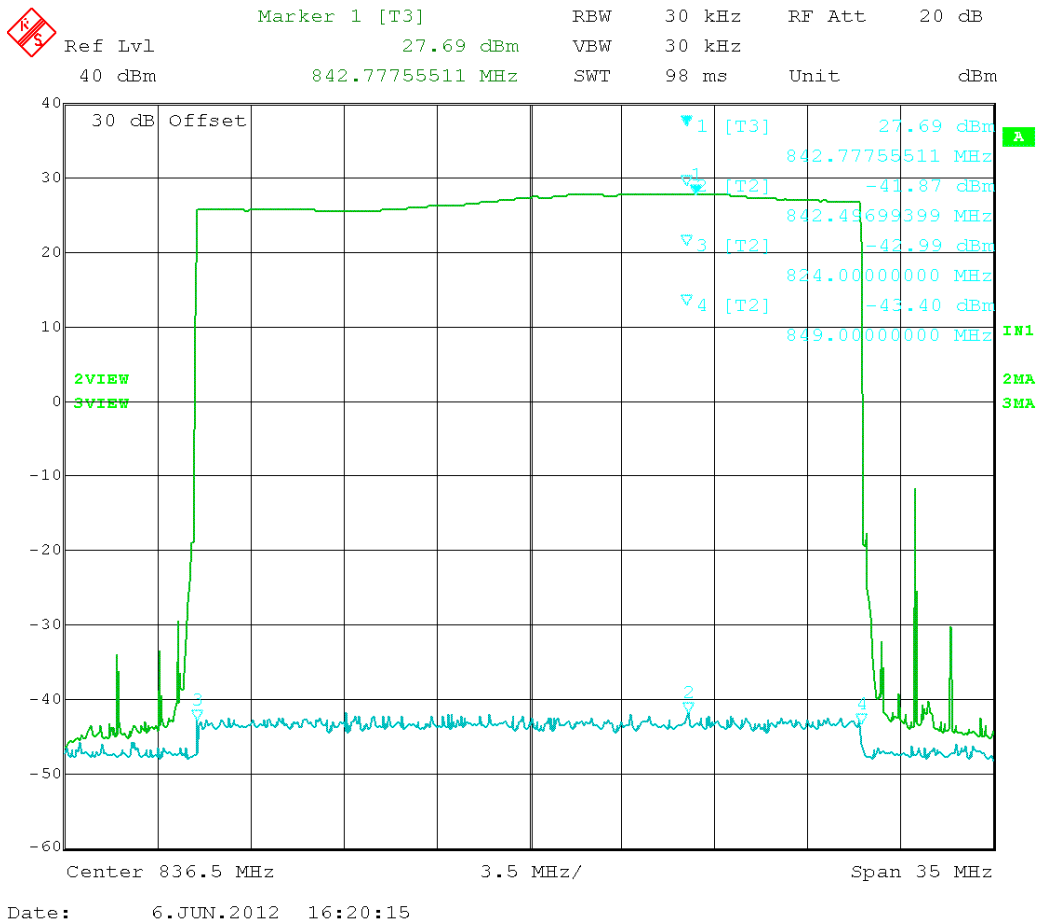

Figure 55. Frequency response (824 – 849) MHz band

Input	-41.87
Output	27.69
Pass Band Gain	69.56

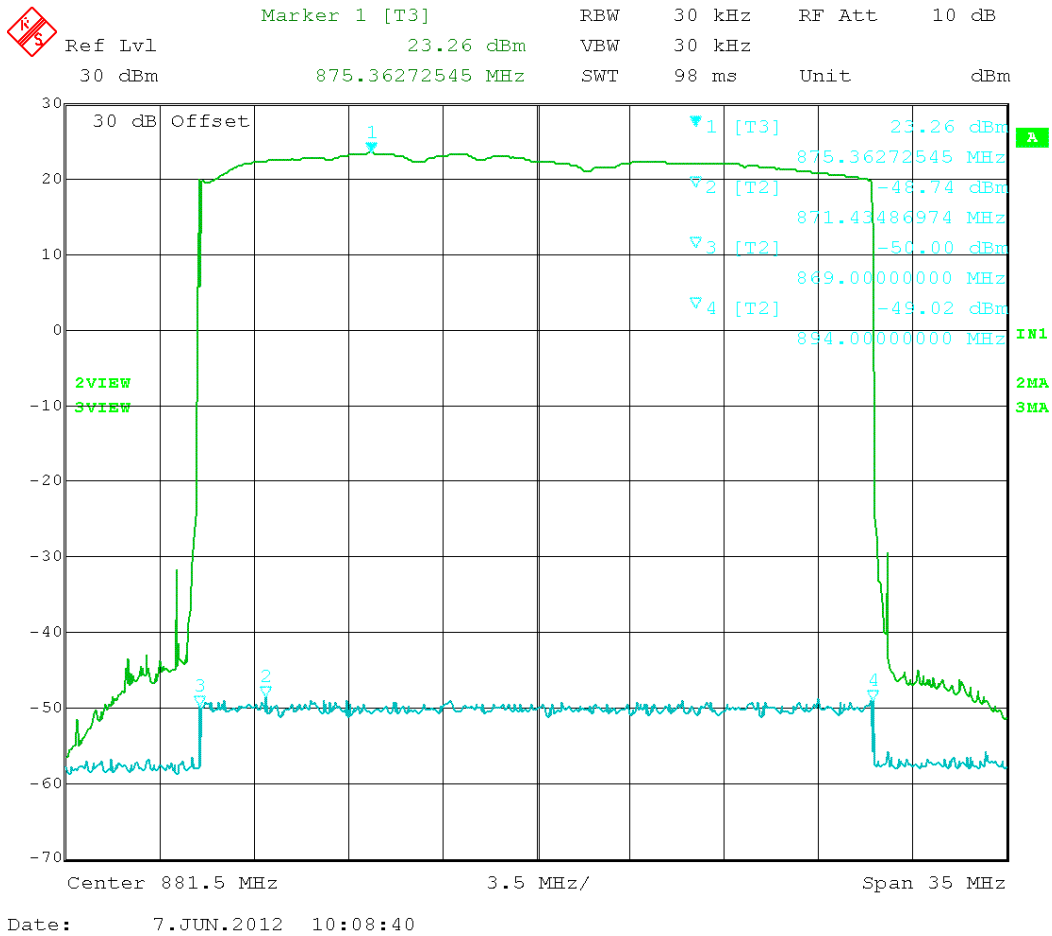

Figure 56. Frequency response (869 – 894) MHz band

Input	-48.74
Output	23.26
Pass Band Gain	72