



849 NW STATE ROAD 45
NEWBERRY, FL 32669 USA
PH: 888.472.2424 OR 352.472.5500
FAX: 352.472.2030
EMAIL: TEI@TIMCOENGR.COM
[HTTP://WWW.TIMCOENGR.COM](http://WWW.TIMCOENGR.COM)

FCC PART 22H, 24E, AND 27 TEST REPORT

Applicant	WILSON ELECTRONICS, INC.
Address	3301 E. DESERET DRIVE ST. GEORGE UTAH 84790 USA
FCC ID	PWO275165
Model Number	275165
Product Description	TRI-BAND SIGNAL BOOSTER
Date Sample Received	12/28/2011
Date Tested	1/17/2012
Tested By	Nam Nguyen
Approved By	Mario de Aranzeta
Report No.	3089AUT11TestReport.doc
Test Results	<input checked="" type="checkbox"/> PASS <input type="checkbox"/> FAIL

THE ATTACHED REPORT SHALL NOT BE REPRODUCED EXCEPT IN FULL
WITHOUT THE WRITTEN APPROVAL OF TIMCO ENGINEERING, INC.



Test Certificate #0955-01



TABLE OF CONTENTS

ATTESTATION STATEMENT.....	4
REPORT SUMMARY	5
TEST ENVIRONMENT	5
TEST SETUP	5
DEVICE UNDER TEST INFORMATION	6
EQUIPMENT LIST	7
TEST PROCEDURE.....	8
RF POWER OUTPUT	11
Test Data Table 1 – Output Power – CDMA 1900 – Uplink/Downlink.....	11
Test Data Table 2 – Output Power – EDGE 1900 – Uplink/Downlink	11
Test Data Table 3 – Output Power – GSM 1900 – Uplink/Downlink	11
Test Data Table 4 – Output Power – WCDMA 1900 – Uplink/Downlink.....	11
Test Data Table 5 – Output Power – LTE 1900 – Uplink/Downlink.....	12
Test Data Table 6 – Output Power – CDMA 800 – Uplink/Downlink.....	12
Test Data Table 7 – Output Power – EDGE 800 – Uplink/Downlink	12
Test Data Table 8 – Output Power – GSM 800 – Uplink/Downlink	12
Test Data Table 9 – Output Power – WCDMA 800 – Uplink/Downlink.....	12
Test Data Table 10 – Output Power – LTE 800 – Uplink/Downlink.....	13
Test Data Table 11 – Output Power – LTE 700 – Uplink/Downlink.....	13
INPUT/OUTPUT MODULATED AMPLITUDE COMPARISON AND BAND-EDGES COMPLIANCE	14
Test Data Table 12 – CDMA 1900 – Uplink/Downlink.....	15
Test Data Table 13 – WCDMA 1900 – Uplink/Downlink.....	19
Test Data Table 14 – LTE 1900 – Uplink/Downlink.....	23
Test Data Table 15 – EDGE 1900 – Uplink/Downlink	27
Test Data Table 16 –GSM 1900 – Uplink/Downlink	31
Test Data Table 17 – CDMA 800 – Uplink/Downlink.....	35
Test Data Table 18 – WCDMA 800 – Uplink/Downlink.....	39
Test Data Table 19 – LTE 800 – Uplink/Downlink.....	43
Test Data Table 20 – EDGE 800 – Uplink/Downlink	47
Test Data Table 21 – GSM 800 – Uplink/Downlink	51
Test Data Table 22 – LTE 700 – Uplink/Downlink.....	55
INTERMODULATION PRODUCT SPURIOUS EMISSIONS.....	59
SPURIOUS EMISSIONS AT ANTENNA TERMINALS	68
Test Data Table 23 – Conducted Emissions – CDMA 1900 – Uplink	68
Test Data Table 24 – Conducted Emissions – CDMA 1900 – Downlink.....	68
Test Data Table 25 – Conducted Emissions – GSM 1900 - Uplink	69
Test Data Table 26 – Conducted Emissions – GSM 1900 - Downlink.....	69
Test Data Table 27 – Conducted Emissions – CDMA 800 - Uplink.....	69
Test Data Table 28 – Conducted Emissions – CDMA 800 - Downlink	70
Test Data Table 29 – Conducted Emissions – GSM 800 – Uplink.....	70
Test Data Table 30 – Conducted Emissions – GSM 800 - Downlink.....	70
OUT OF BAND REJECTION: FREQUENCY RESPONSE	71
FIELD STRENGTH OF SPURIOUS EMISSIONS	75

APPLICANT: WILSON ELECTRONICS, INC.

FCC ID: PWO275165

Report #: W\WILSON_PWO\3089AUT11\3089AUT11TestReport.doc Page 2 of 76



Test Data Table 31 – Radiated Emissions – CW (1900 MHz) – Uplink /Downlink..... 75
Test Data Table 32 – Radiated Emissions – CW (800 MHz) – Uplink /Downlink 76

ATTESTATION STATEMENT

Summary

The device under test does:

- fulfill the general approval requirements as identified in this test report
- not fulfill the general approval requirements as identified in this test report

This equipment has been tested in accordance with the standards identified in this test report. To the best of my knowledge and belief, these tests were performed using the measurement procedures described in this report. All instrumentation and accessories used to test products for compliance to the indicated standards are calibrated regularly in accordance with ISO 17025:2005 requirements.



Certificate # 0955-01

I attest that the necessary measurements were made, under my supervision, at TIMCO ENGINEERING, INC. located at 849 N.W. State Road 45, Newberry, Florida 32669.

Authorized Signatory Name: Mario de Aranzeta



Signature:

Function: Engineer

Date:

February/28/2012

REPORT SUMMARY

Disclaimer	The test results relate only to the items tested.
Report Purpose	To demonstrate the DUT comply with FCC Part 22H and Pt 24 requirements for a dual band signal booster
Applicable Rule Part(s)	Pt 22, Pt 24, Pt 15.109
Test Procedure(s)	ANSI/TIA-603-C: 2004

TEST ENVIRONMENT

Test Facilities	All required tests were performed by Timco Engineering Inc. that is located at 849 NW State Road 45 Newberry, FL 32669.
Test Conditions	Temperature: 26°C Relative Humidity: 50%

TEST SETUP

Deviation to the rules	There was no deviation from the test standards.
Modification to the DUT	No modification was made to the DUT.
Test Exercise (e.g. software description, test signal, etc.)	The DUT was placed in continuous transmit mode of operation.

DEVICE UNDER TEST INFORMATION

Manufactured by	WILSON ELECTRONICS, INC.
DUT Description	TRI-BAND SIGNAL BOOSTER
FCC ID	PWO275165
Model Name	275165
Operating Frequency	Uplink 776 – 787 MHz Downlink 746 – 757 MHz Uplink 824 – 849 MHz Downlink 869 – 894 MHz Uplink 1850 – 1910 MHz Downlink 1930 – 1990 MHz
Emission Designators	F9W (CDMA & WCDMA), GXW (GSM) G7W (EDGE)
Modulation(s)	CDMA, WCDMA, LTE, GSM, EDGE, HSPA, EVDO
User Power Range & Control	Yes
Test Item	Pre-Production
DC Voltage and Current into final amplifier	Uplink: Vcc = 776 – 787 MHz: 4.1 Vdc, 0.5A 824-849 MHz: 4.1 Vdc, 0.5A 1850-1910 MHz: 4.1 Vdc, 0.5A Downlink: Vcc= 746-757 MHz: 4.1 Vdc, 0.5A 869-894 MHz: 4.1 Vdc, 0.5A 1930-1990 MHz: 4.1 Vdc, 0.5A
Type of Equipment	Fixed

EQUIPMENT LIST

Device	Manufacturer	Model	Serial Number	Cal/Char Date	Due Date
3-Meter Semi-Anechoic Chamber	Panashield	N/A	N/A	Listed 5/10/10	5/10/12
AC Voltmeter	HP	400FL	2213A14499	CAL 6/12/11	6/12/13
Antenna: Active Loop	ETS-Lindgren	6502	00062529	CAL 9/23/10	9/23/12
Frequency Counter	HP	5385A	2730A03025	CAL 8/17/11	8/17/13
Hygro-Thermometer	Extech	445703	0602	CAL 6/15/11	6/15/13
Modulation Analyzer	HP	8901A	3435A06868	CAL 7/18/11	7/18/13
Digital Multimeter	Fluke	FLUKE-77	35053830	CAL 9/9/11	9/9/13
Analyzer Tan Tower Preamplifier	HP	8449B-H02	3008A00372	CAL 10/28/11	10/28/13
Analyzer Tan Tower Quasi-Peak Adapter	HP	85650A	3303A01690	CAL 10/28/11	10/28/13
Analyzer Tan Tower RF Preselector	HP	85685A	3221A01400	CAL 10/28/11	10/28/13
Analyzer Tan Tower Spectrum Analyzer	HP	8566B Opt 462	3138A07786 3144A20661	CAL 10/28/11	10/28/13
Antenna	ETS	3117	35923	12/7/2011	12/7/2013
Antenna	Electro metrics	LPA-25	1122	5/04/2011	5/04/2013
Antenna	Electro metrics	BIA-25	1096	5/04/2011	5/04/2013

APPLICANT: WILSON ELECTRONICS, INC.

FCC ID: PWO275165

Report #: W\WILSON_PWO\3089AUT11\3089AUT11TestReport.doc Page 7 of 76

TEST PROCEDURE

RF Power Output

RF power is measured by connecting a 50-ohm, resistive wattmeter to the RF output connector. With a nominal voltage and the amplifier properly adjusted the RF output measures.

RF Output Power Test Setup Diagram

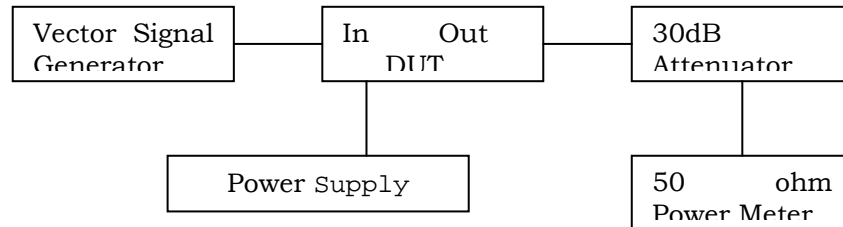

Input/Output Modulated Amplitude Comparison And Band-Edges Compliance

On the following plot, the reference level was calibrated using a resolution bandwidth wider than the emission bandwidth. First the gain was measured for the maximum output power. Then for each frequency and type of modulation, an attenuation equals to the gain of the amplifier was added on the measurement side of the amplifier, as to overlay the input versus output modulated envelope.

Test Setup Diagram

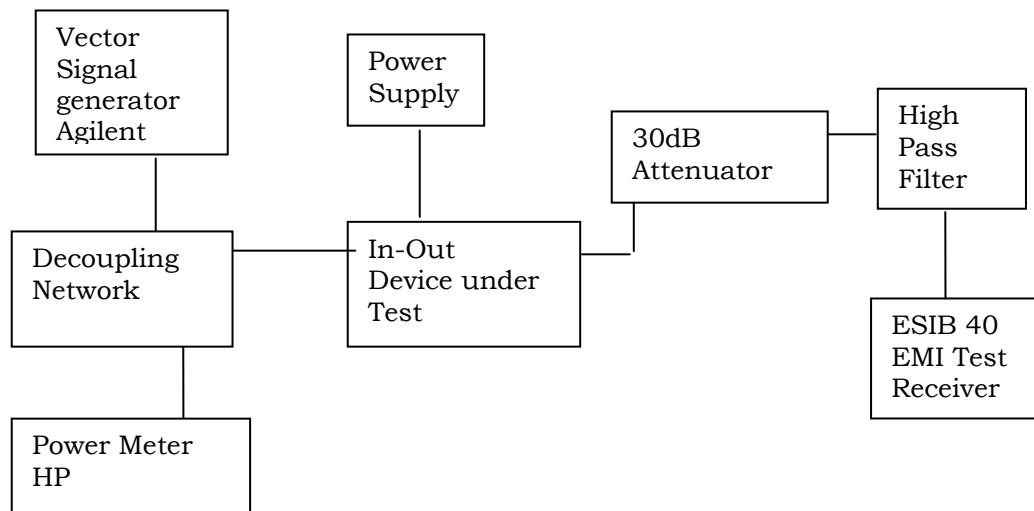

[Continued]

Intermodulation Product Spurious Emissions

The procedure used was ANSI/TIA-603-C: 2004. The spectrum was scanned from 9kHz to at least the tenth harmonic of the fundamental using a HP 8566B spectrum analyzer.

The modulation type was tested using the two-tone / three tone test method. The input power to the amplifier was set at maximum drive level by combining the two tones. The two tones were chosen in such a way (1) the third order intermodulation product frequencies are located within the pass band of the DUT and (2) they produce the worst-case emissions out of band.

Setup Diagram

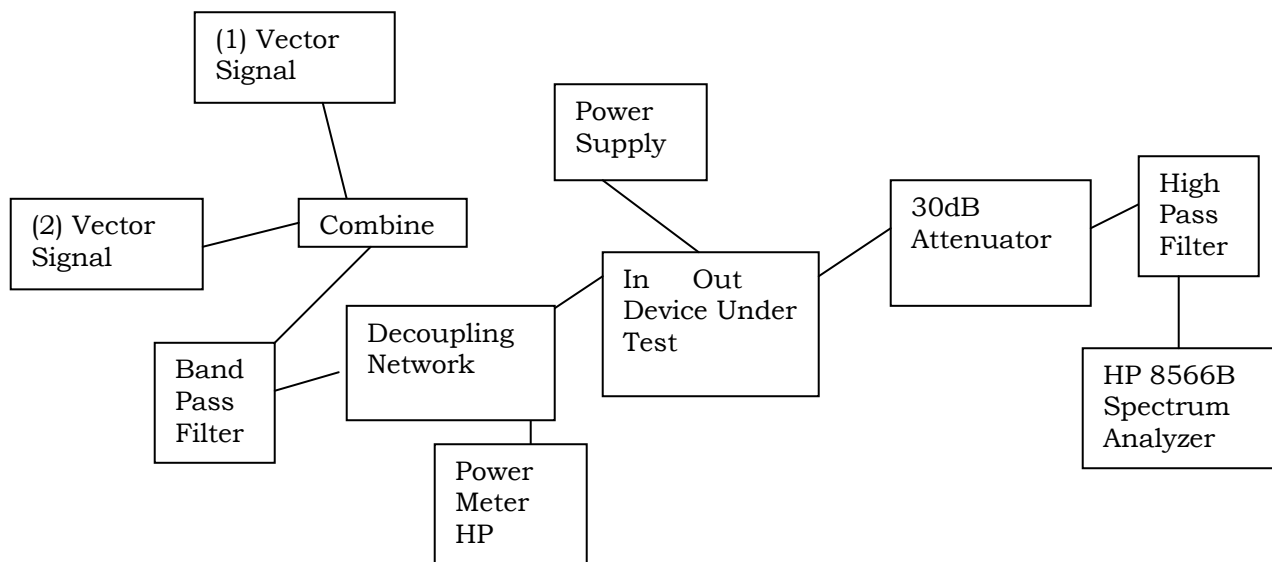

Spurious Emissions at Antenna Terminals

The procedure used was ANSI/TIA-603-C: 2004. The spectrum was scanned from 9kHz to at least the tenth harmonic of the fundamental using a HP model 8566B spectrum analyzer.

Data on the following page shows the level of conducted spurious responses. For analog modulation, the carrier was modulated 100% using a 2500 Hz tone. For digital modulation, the carrier is modulated to its maximum extent. The spectrum was scanned from 9 kHz to at least the 10th harmonic of the fundamental. The measurements were made in accordance with standard ANSI/TIA-603-C: 2004. The maximum input power was set for each test.

[Continued]

Conducted Spurious Emissions Test Setup Diagram

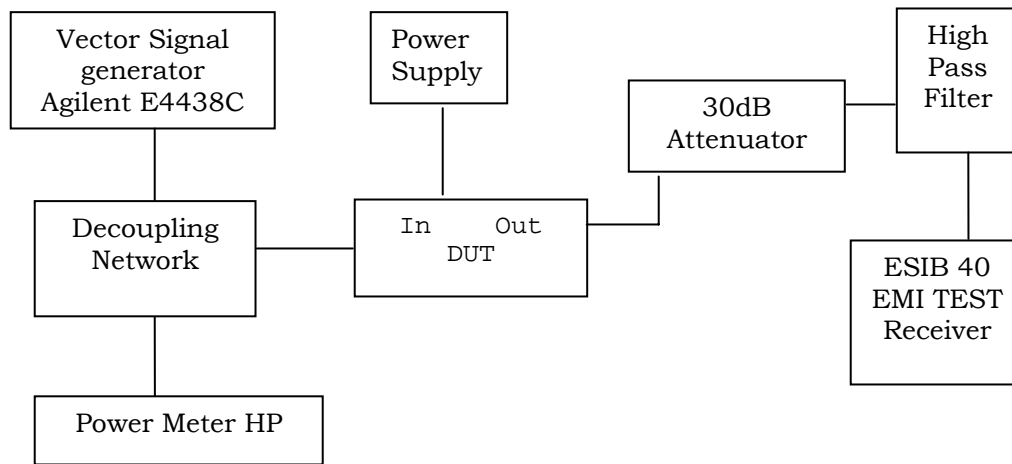

Radiated Spurious Emissions

The spectrum was scanned from 30 MHz to at least the tenth harmonic of the fundamental. The CW signal was used to perform this test. This test was conducted per ANSI/TIA-603-C: 2004 using the substitution method.

Radiated Spurious Emissions Test Setup Diagram

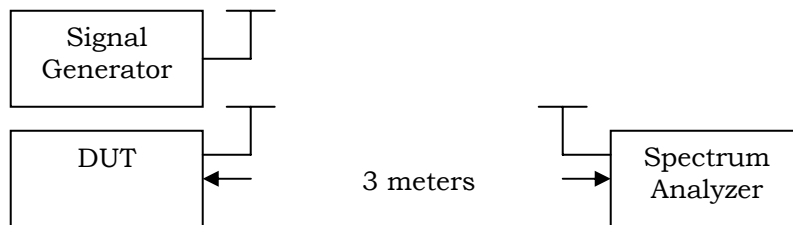

Equipment placed 80 cm above ground on a rotating table platform.



RF POWER OUTPUT

Rule Part(s) No.: Pt 2.1046(a)

Requirements: Pt 2.1046(a)

Test Result: As the following table indicates. Notes: the maximum power output value was obtained with CDMA modulation at 1868MHz and 1940MHz.

Test Data Table 1 – Output Power – CDMA 1900 – Uplink/Downlink

Tuned Frequency (MHz)	Power Input (dBm)	Power Output (dBm)	Power Output (mW)	Tuned Frequency (MHz)	Power Input (dBm)	Power Output (dBm)	Power Output (mW)
1851.25	-41.0	28.2	661	1931.25	-48.0	21.2	132
1880.00	-42.0	29.4	871	1960.00	-49.0	23.3	214
1908.75	-40.0	26.9	490	1988.75	-49.0	23.1	204

Test Data Table 2 – Output Power – EDGE 1900 – Uplink/Downlink

Tuned Frequency (MHz)	Power Input (dBm)	Power Output (dBm)	Power Output (mW)	Tuned Frequency (MHz)	Power Input (dBm)	Power Output (dBm)	Power Output (mW)
1850.20	-41.0	27.1	513	1930.20	-48.0	20.1	102
1880.00	-42.0	28.3	676	1960.00	-49.0	22.4	174
1909.80	-40.0	25.0	316	1989.80	-49.0	21.5	141

Test Data Table 3 – Output Power – GSM 1900 – Uplink/Downlink

Tuned Frequency (MHz)	Power Input (dBm)	Power Output (dBm)	Power Output (mW)	Tuned Frequency (MHz)	Power Input (dBm)	Power Output (dBm)	Power Output (mW)
1850.20	-41.0	27.2	525	1930.20	-46.0	21.8	151
1880.00	-42.0	28.7	741	1960.00	-46.0	25.1	324
1909.80	-40.0	25.1	324	1989.80	-46.0	24.4	275

Test Data Table 4 – Output Power – WCDMA 1900 – Uplink/Downlink

Tuned Frequency (MHz)	Power Input (dBm)	Power Output (dBm)	Power Output (mW)	Tuned Frequency (MHz)	Power Input (dBm)	Power Output (dBm)	Power Output (mW)
1852.75	-43.0	26.0	398	1932.75	-51.0	18.9	78
1880.00	-46.0	26.1	407	1960.00	-52.0	20.8	120
1907.25	-43.0	24.7	295	1987.25	-52.0	21.0	126

[Continued]

APPLICANT: WILSON ELECTRONICS, INC.

FCC ID: PWO275165

Report #: W\WILSON_PWO\3089AUT11\3089AUT11TestReport.doc Page 11 of 76

Test Data Table 5 – Output Power – LTE 1900 – Uplink/Downlink

Tuned Frequency (MHz)	Power Input (dBm)	Power Output (dBm)	Power Output (mW)
1855.00	-45.0	25.5	355
1880.00	-47.0	25.8	380
1905.00	-45.0	25.6	363

Tuned Frequency (MHz)	Power Input (dBm)	Power Output (dBm)	Power Output (mW)
1935.00	-49.0	22.8	191
1960.00	-49.0	24.1	257
1985.00	-49.0	25.1	324

Test Data Table 6 – Output Power – CDMA 800 – Uplink/Downlink

Tuned Frequency (MHz)	Power Input (dBm)	Power Output (dBm)	Power Output (mW)
825.25	-43.0	25.8	380
836.50	-43.0	28.5	708
847.75	-43.0	26.4	437

Tuned Frequency (MHz)	Power Input (dBm)	Power Output (dBm)	Power Output (mW)
870.25	-52.0	21.7	148
881.50	-52.0	21.8	151
892.75	-51.0	20.0	100

Test Data Table 7 – Output Power – EDGE 800 – Uplink/Downlink

Tuned Frequency (MHz)	Power Input (dBm)	Power Output (dBm)	Power Output (mW)
824.20	-43.0	25.1	324
836.50	-43.0	27.7	589
848.80	-43.0	25.5	355

Tuned Frequency (MHz)	Power Input (dBm)	Power Output (dBm)	Power Output (mW)
869.20	-52.0	21.2	132
881.50	-52.0	21.5	141
893.80	-51.0	19.3	85

Test Data Table 8 – Output Power – GSM 800 – Uplink/Downlink

Tuned Frequency (MHz)	Power Input (dBm)	Power Output (dBm)	Power Output (mW)
824.20	-42.0	26.1	407
836.50	-42.0	28.6	724
848.80	-42.0	26.5	447

Tuned Frequency (MHz)	Power Input (dBm)	Power Output (dBm)	Power Output (mW)
869.20	-48.0	24.7	295
881.50	-48.0	24.9	309
893.80	-48.0	22.0	158

Test Data Table 9 – Output Power – WCDMA 800 – Uplink/Downlink

Tuned Frequency (MHz)	Power Input (dBm)	Power Output (dBm)	Power Output (mW)
826.50	-46.0	23.6	229
836.50	-47.0	25.3	339
846.50	-45.0	25.0	316

Tuned Frequency (MHz)	Power Input (dBm)	Power Output (dBm)	Power Output (mW)
871.50	-55.0	19.4	87
881.50	-54.0	20.2	105
891.50	-53.0	19.0	79



Test Data Table 10 – Output Power – LTE 800 – Uplink/Downlink

Tuned Frequency (MHz)	Power Input (dBm)	Power Output (dBm)	Power Output (mW)
829.00	-47.0	23.0	200
836.50	-47.0	24.7	295
844.00	-47.0	24.0	251

Tuned Frequency (MHz)	Power Input (dBm)	Power Output (dBm)	Power Output (mW)
874.00	-51.0	22.7	186
881.50	-52.0	22.1	162
889.00	-51.0	20.3	107

Test Data Table 11 – Output Power – LTE 700 – Uplink/Downlink

Tuned Frequency (MHz)	Power Input (dBm)	Power Output (dBm)	Power Output (mW)
781.00	-45.0	25.0	316
782.00	-45.0	24.3	269

Tuned Frequency (MHz)	Power Input (dBm)	Power Output (dBm)	Power Output (mW)
751.00	-50.0	22.9	195
752.00	-50.0	22.7	186



INPUT/OUTPUT MODULATED AMPLITUDE COMPARISON AND BAND-EDGES COMPLIANCE

Rule Parts No.: Pt 2.1049, Pt 2.1051, 22H, 24E

Requirements: The power of any emission outside of the authorized operating frequency ranges must be attenuated below the transmitting power (P) by a factor of at least $43 + 10 \log(P)$ dB.

Test Data: The DUT meets the requirements.

Bandedge compliance: Measurements were performed in accordance with Part 24.238

The Reference level on the following plots was calibrated using a 3MHz RBW=VBW.

Compensating for RBW (1%) using $10 \log(12.5/3) = 6.2 \text{ dB}$ we get the following amplitudes at the bandedge:

Test Data Table 12 – CDMA 1900 – Uplink/Downlink				
Channel (MHz)	Bandedge Frequency (MHz)	Amplitude bandedge (dBm)	Limit (dBm)	Margin (dB)
1851.25	1849.89	-17.32	-13	4.32
1908.75	1910.08	-26.46	-13	13.46
1931.25	1929.97	-27.59	-13	14.59
1988.75	1990.05	-23.23	-13	10.23

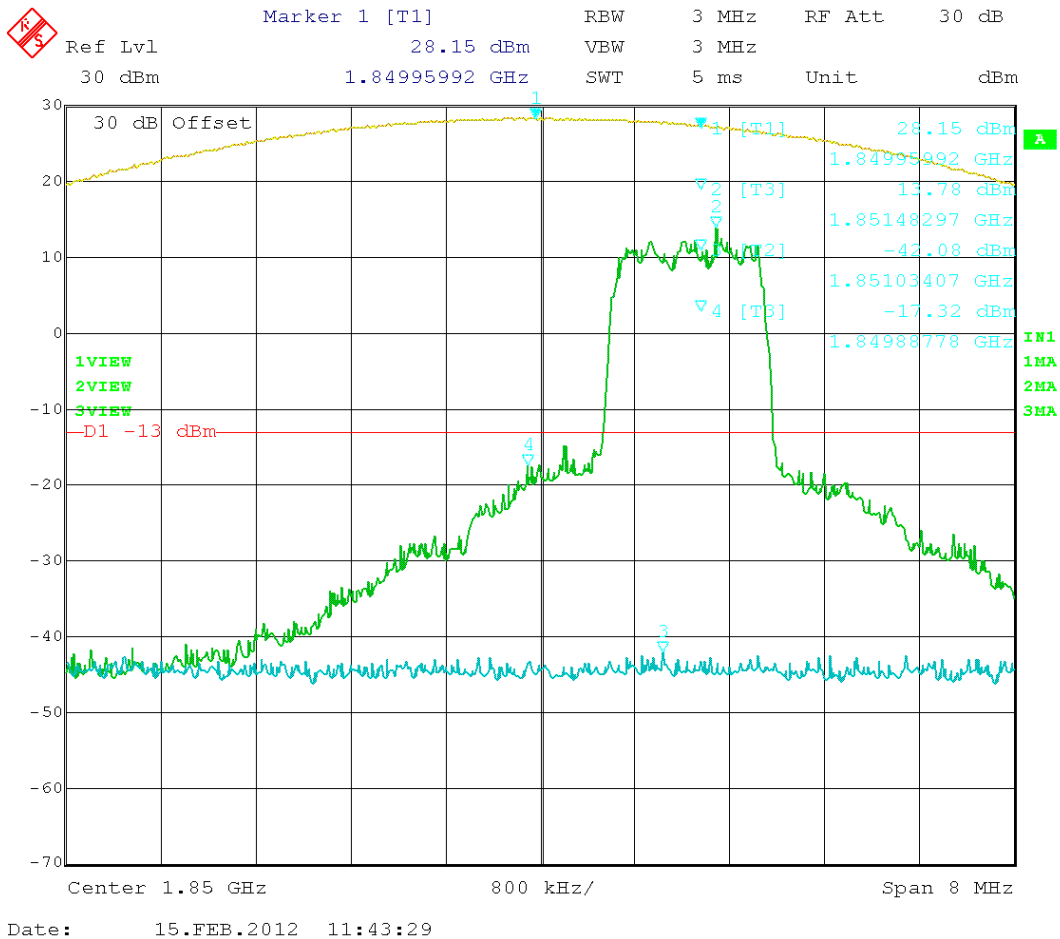

Figure 1: CDMA – In vs. Out 1851.25MHz

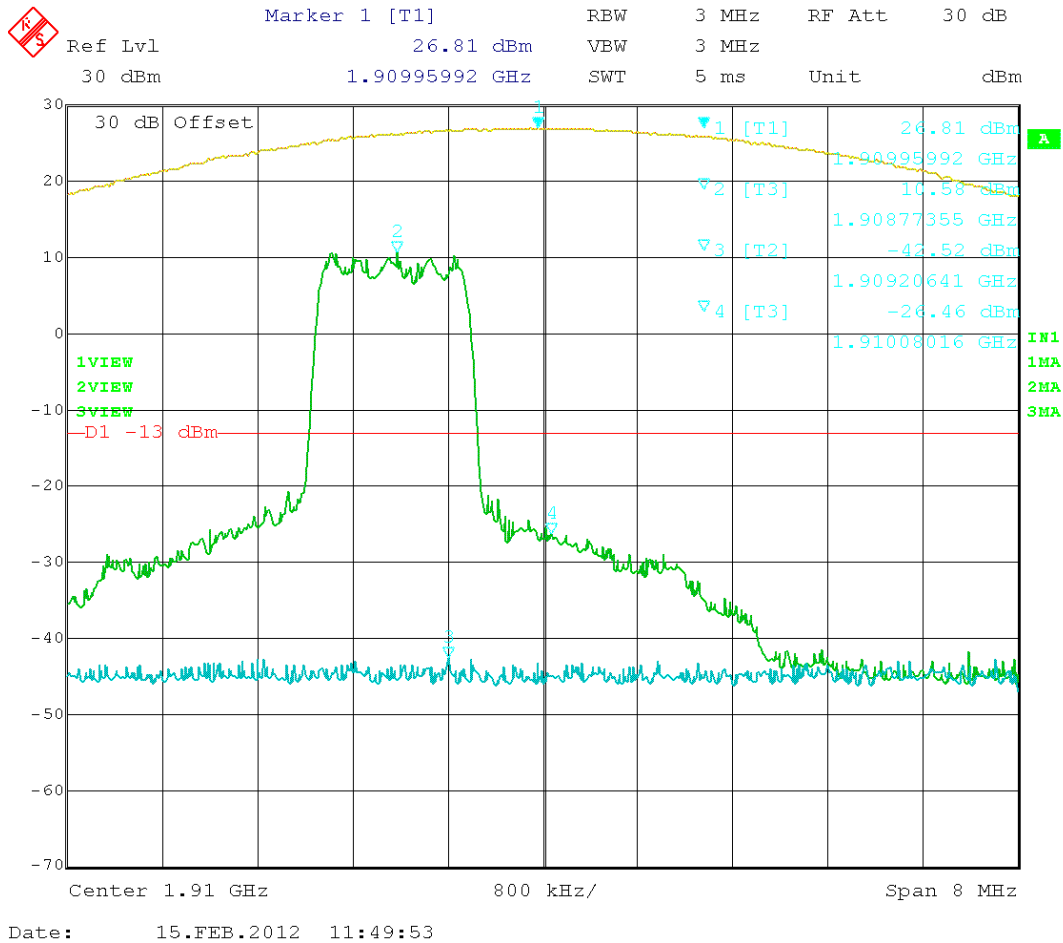

Figure 2: CDMA – In vs. Out 1908.75MHz

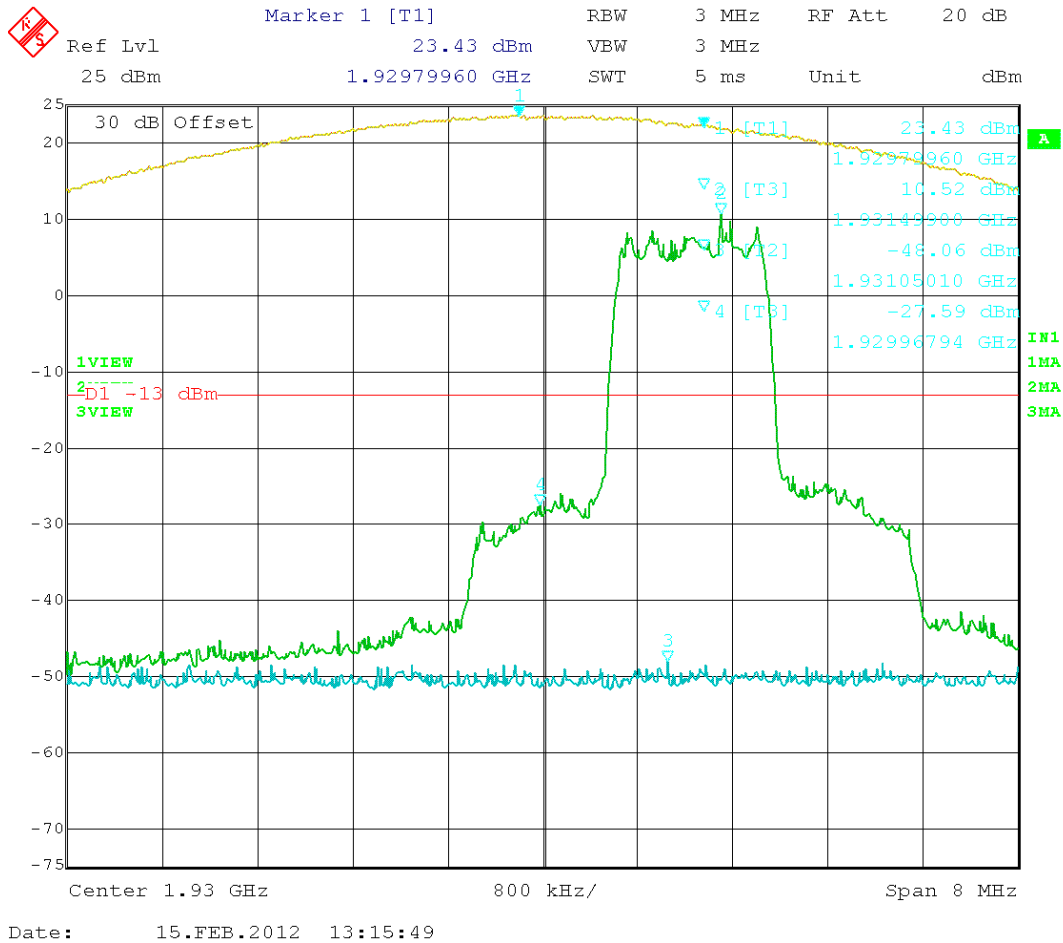

Figure 3: CDMA – In vs. Out 1931.25MHz

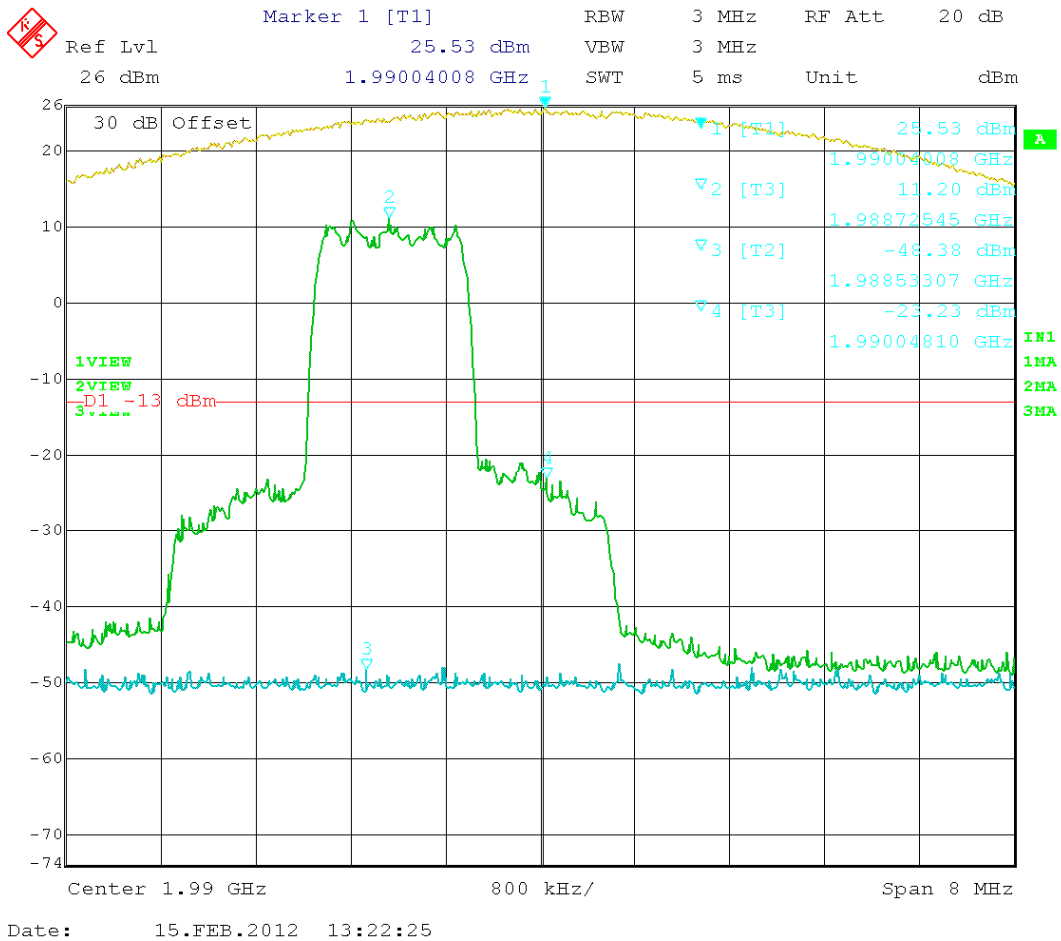

Figure 4: CDMA – In vs. Out 1988.75MHz

Test Data Table 13 – WCDMA 1900 – Uplink/Downlink

Channel (MHz)	Bandedge Frequency (MHz)	Amplitude bandedge (dBm)	Limit (dBm)	Margin (dB)
1852.50	1849.72	-19.23	-13	6.23
1907.50	1910.16	-24.41	-13	11.41
1932.50	1929.92	-29.46	-13	16.46
1987.50	1990.40	-27.4	-13	14.4

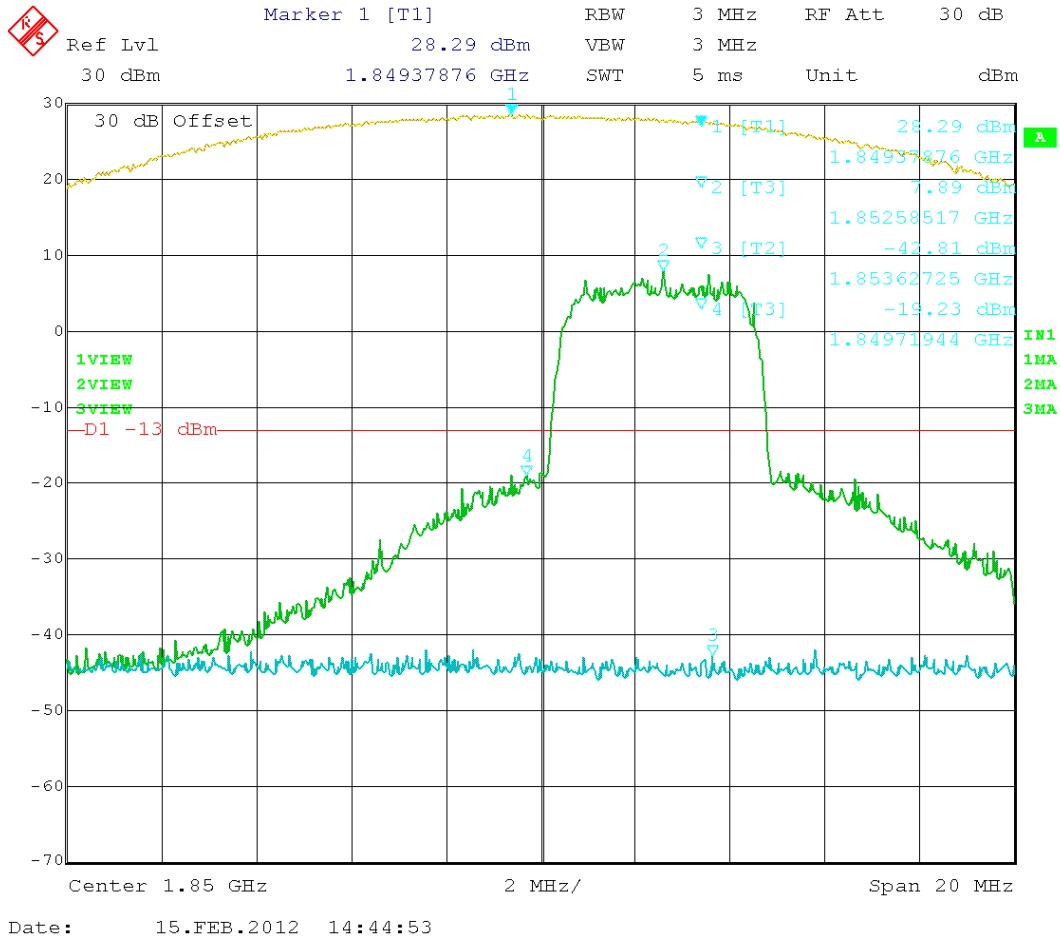

Figure 5: WCDMA – In vs. Out 1852.50 MHz

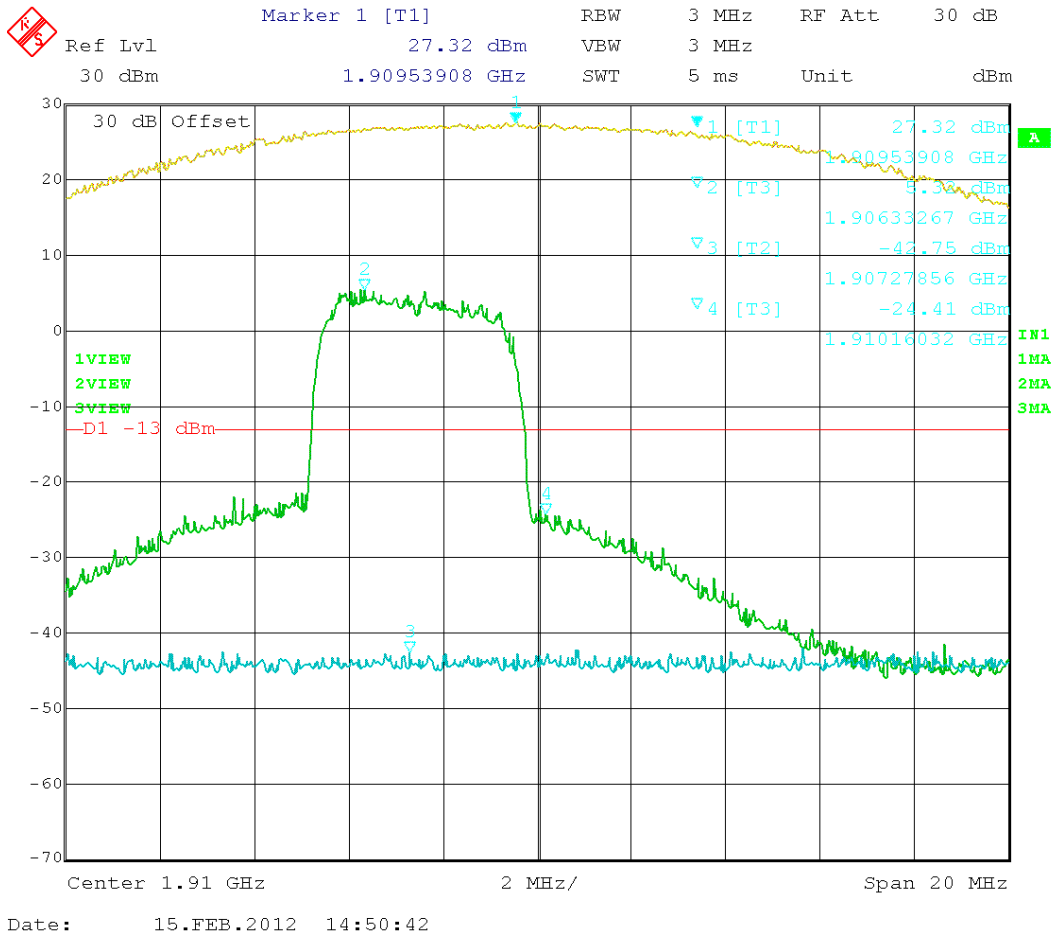

Figure 6: WCDMA – In vs. Out 1907.50 MHz

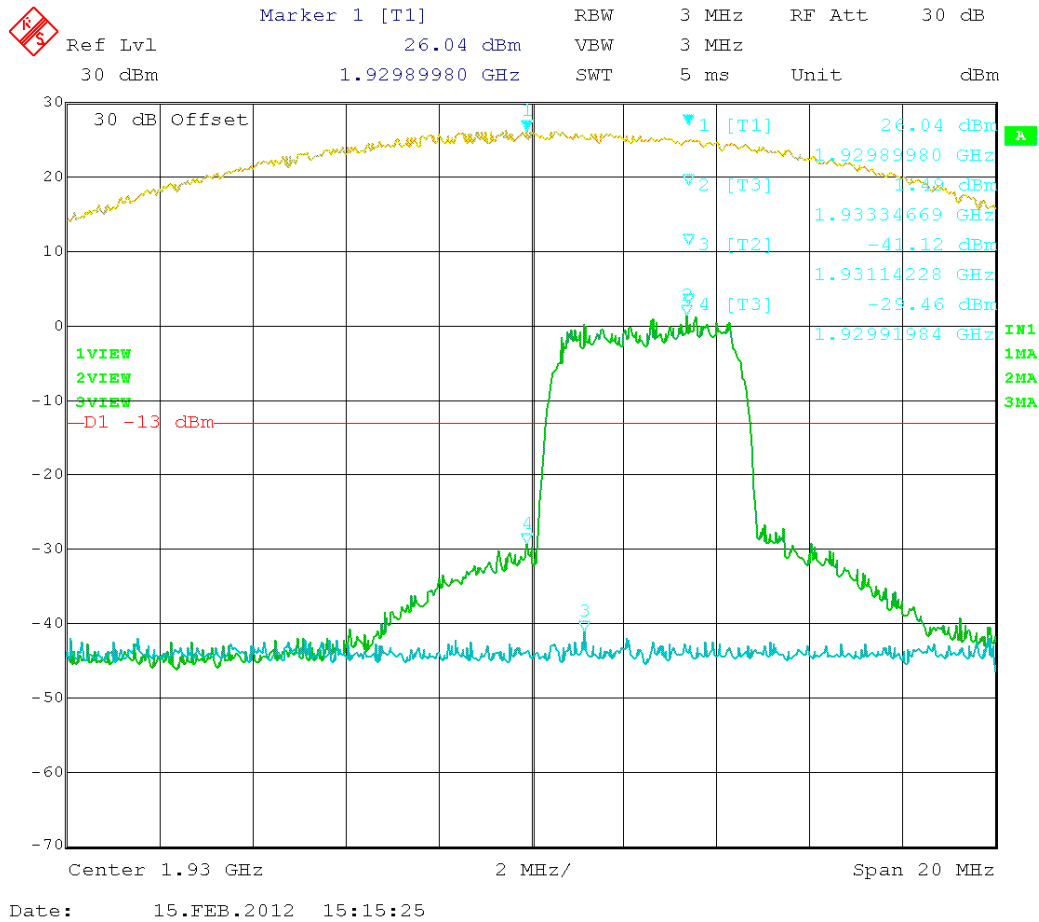
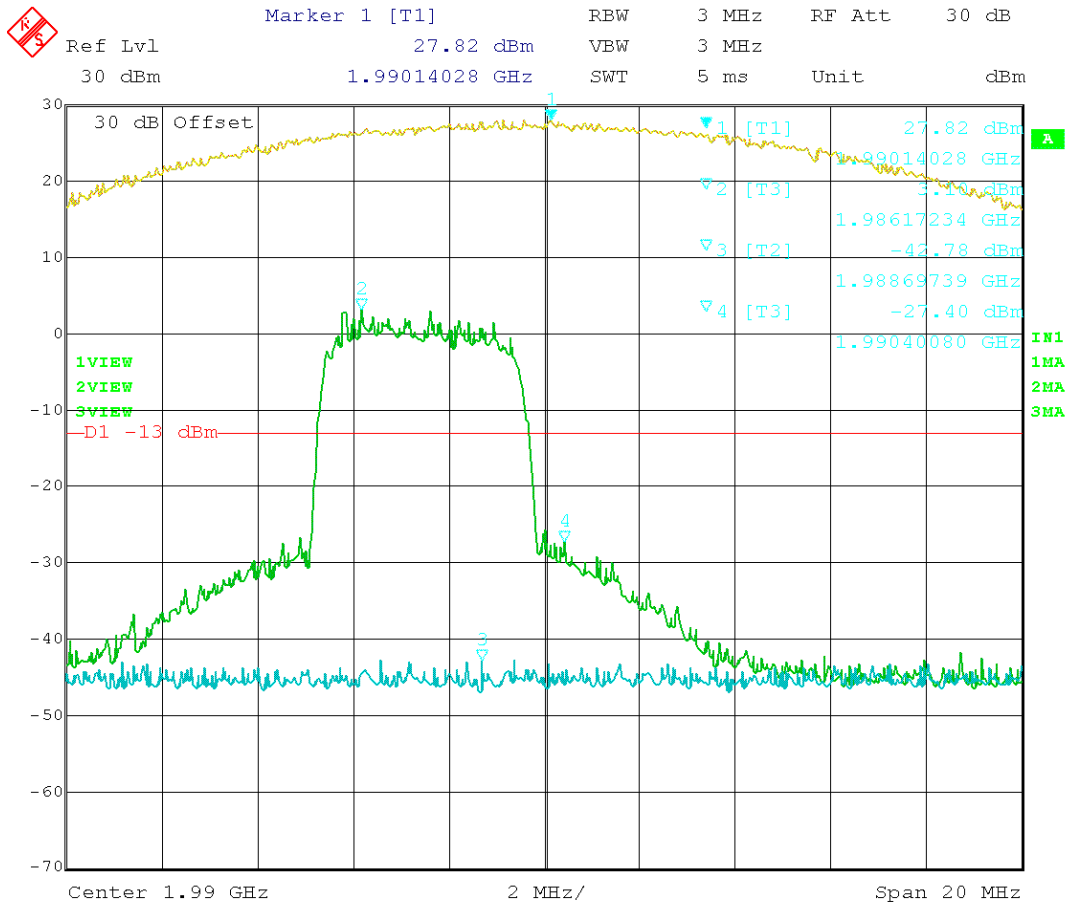

Figure 7: WCDMA – In vs. Out 1932.50 MHz



Date: 15.FEB.2012 15:20:30

Figure 8: WCDMA – In vs. Out 1977.50 MHz

Test Data Table 14 – LTE 1900 – Uplink/Downlink

Channel (MHz)	Bandedge Frequency (MHz)	Amplitude bandedge (dBm)	Limit (dBm)	Margin (dB)
1855.0	1848.46	-24.54	-13	11.54
1905.0	1911.19	-24.72	-13	11.72
1935.0	1928.39	-28.08	-13	15.08
1985.0	1990.28	-24.02	-13	11.02

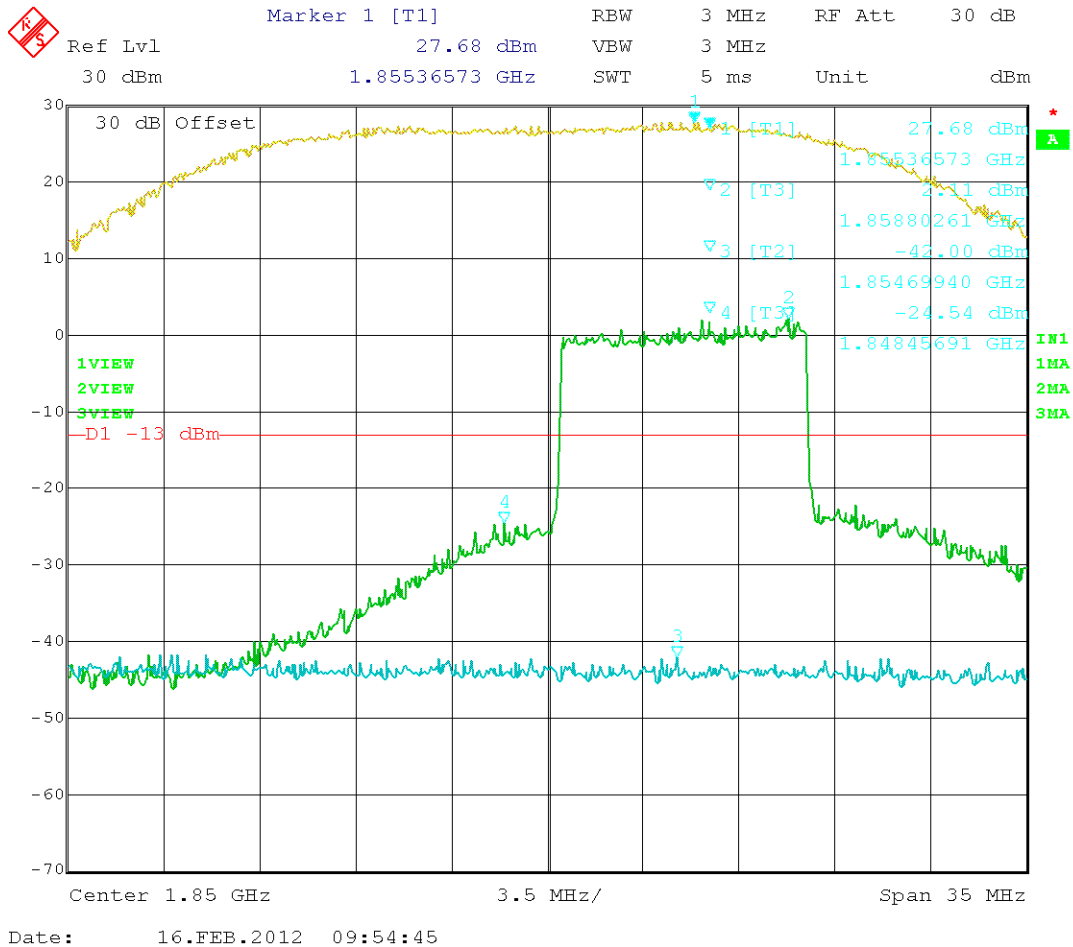
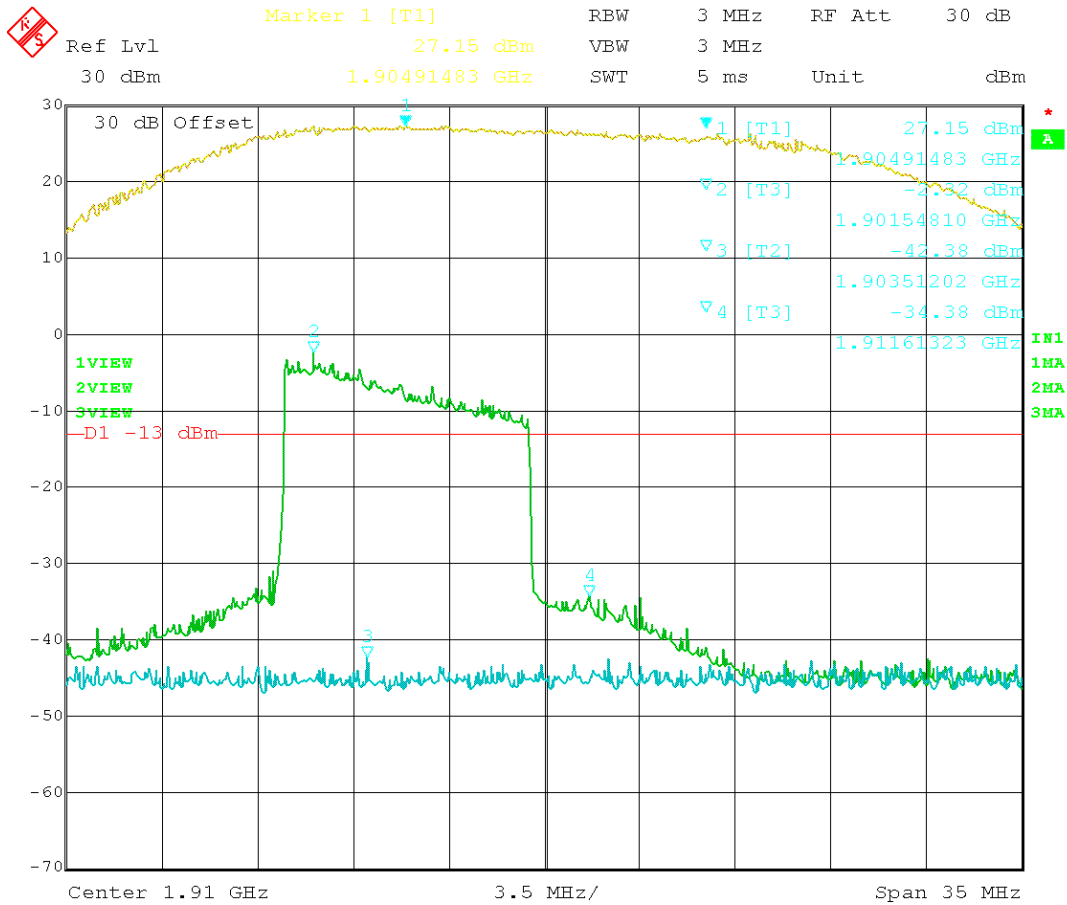

Figure 9: LTE – In vs. Out 1855.00 MHz



Date: 16.FEB.2012 09:40:50

Figure 10: LTE – In vs. Out 1905.00 MHz

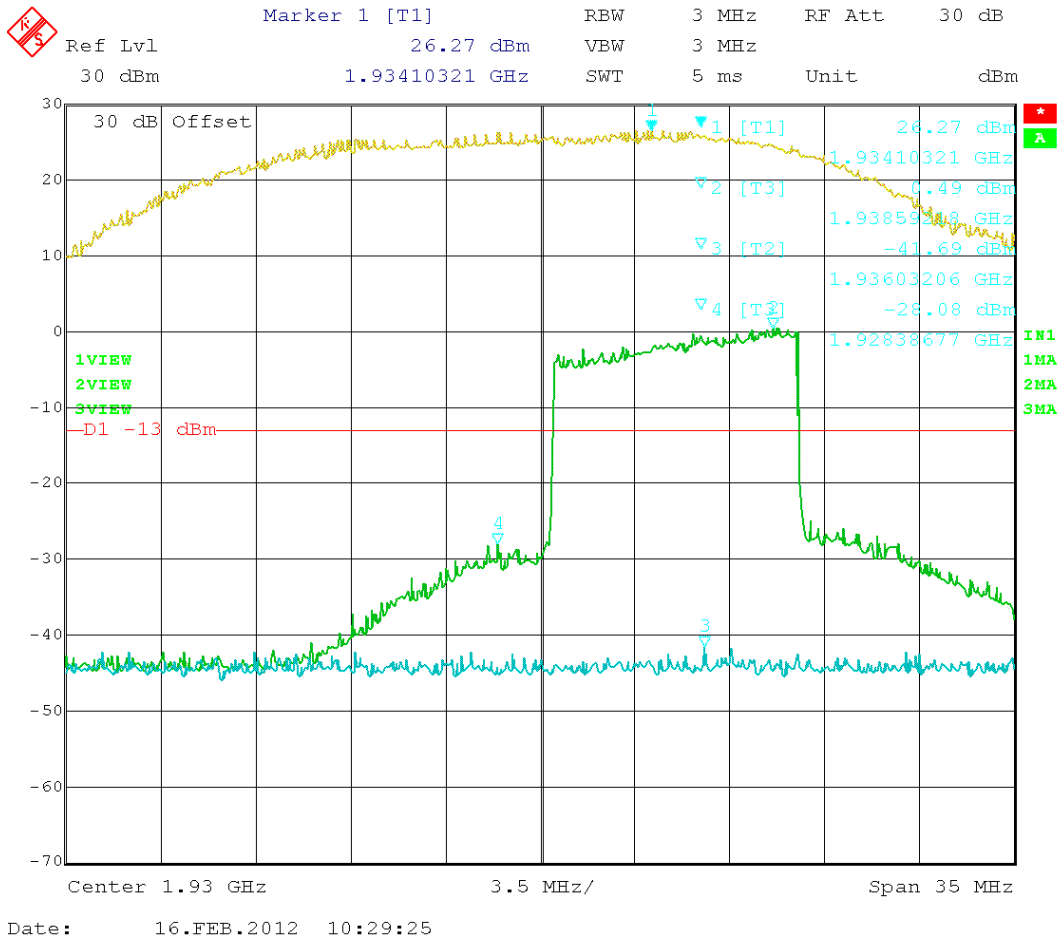
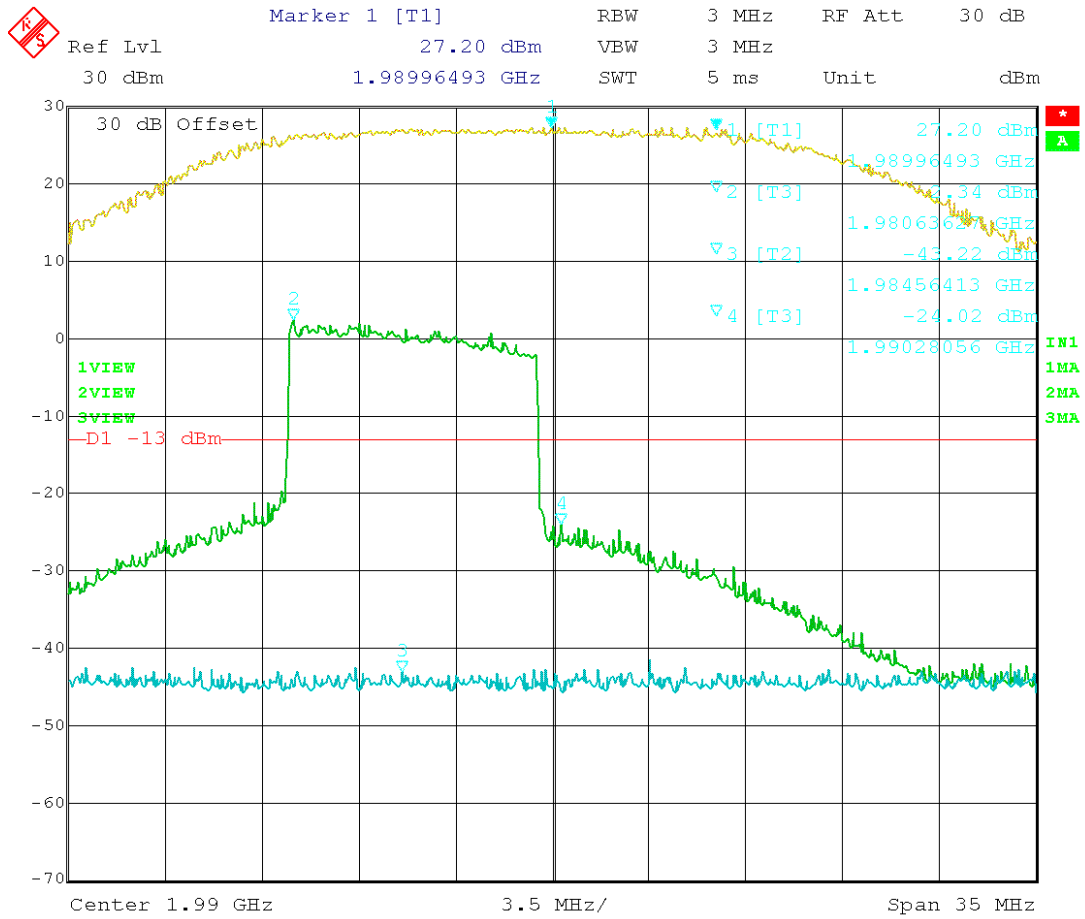

Figure 11: LTE – In vs. Out 1935.00 MHz



Date: 16.FEB.2012 10:41:41

Figure 12: LTE – In vs. Out 1985.00 MHz

Test Data Table 15 – EDGE 1900 – Uplink/Downlink

Channel (MHz)	Band-edge Frequency (MHz)	Amplitude level at the band-edge (dBm)	Limit (dBm)	Margin (dB)
1850.2	1849.98	-15.03	-13	2.03
1909.8	1910.04	-19.66	-13	6.66
1930.2	1929.98	-23.86	-13	10.86
1989.8	1990.02	-23.49	-13	10.49

The Reference level on the following plots was calibrated using a 3MHz RBW=VBW.

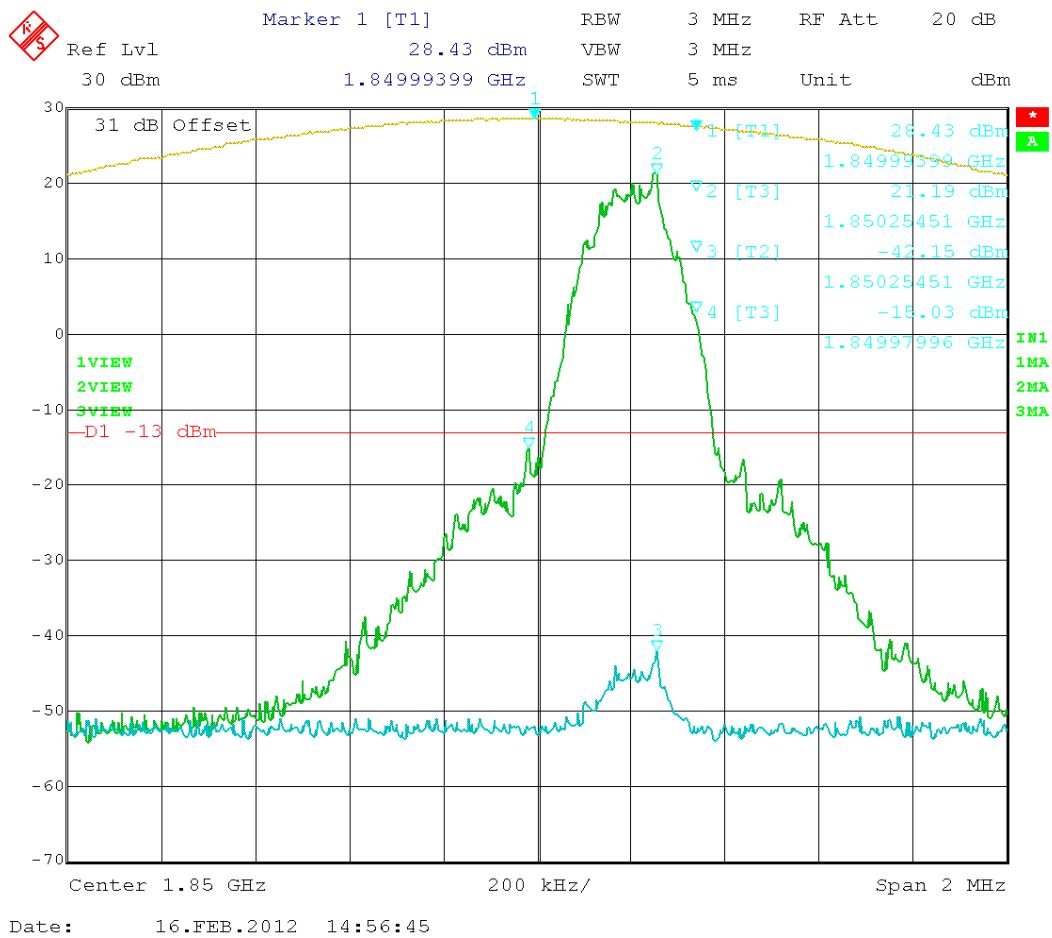

Figure 9: EDGE – In vs. Out 1850.20MHz

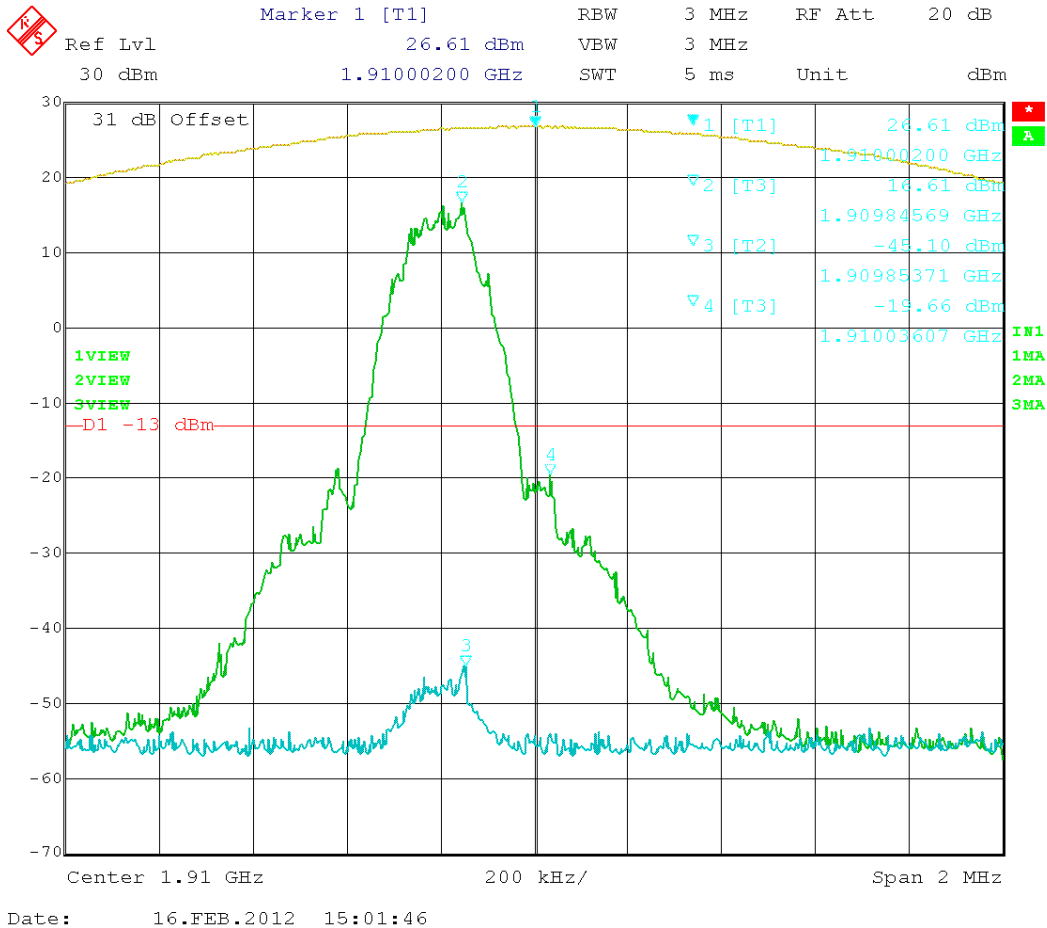

Figure 10: EDGE – In vs. Out 1909.80MHz

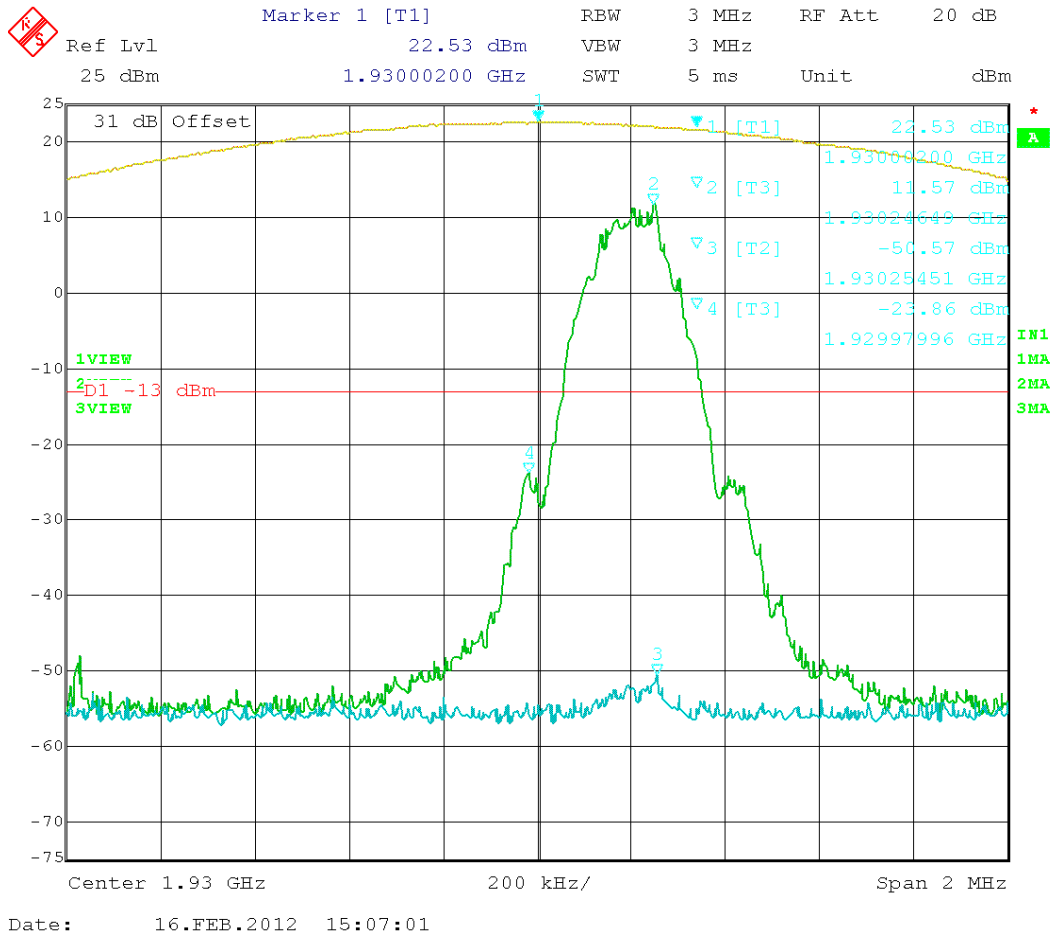
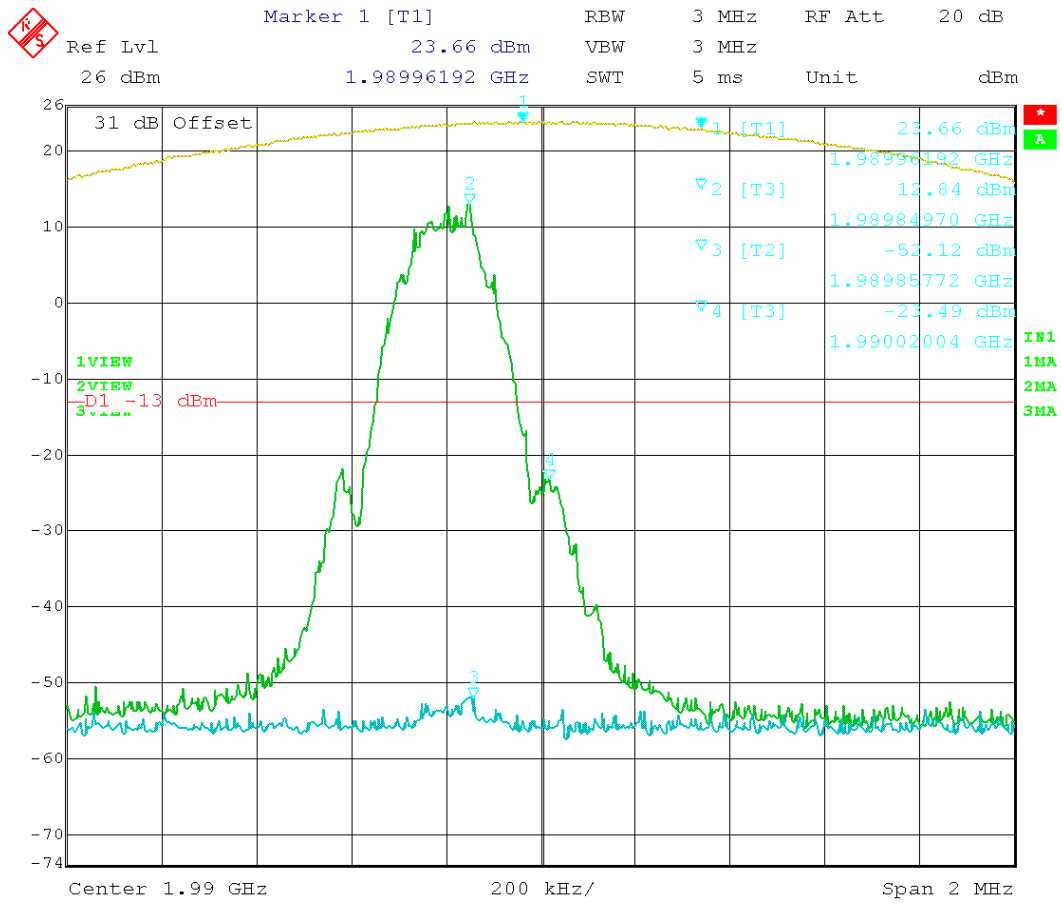

Figure 11: EDGE – In vs. Out 1930.20MHz



Date: 16.FEB.2012 15:16:30

Figure 12: EDGE – In vs. Out 1989.80MHz

Test Data Table 16 –GSM 1900 – Uplink/Downlink

Channel (MHz)	Band-edge Frequency (MHz)	Amplitude level at the band-edge (dBm)	Limit (dBm)	Margin (dB)
1850.2	1849.98	-14.81	-13	1.81
1909.8	1910.02	-18.29	-13	5.29
1930.2	1929.98	-20.11	-13	7.11
1989.8	1990.02	-18.53	-13	5.53

The Reference level on the following plots was calibrated using a 3MHz RBW=VBW.

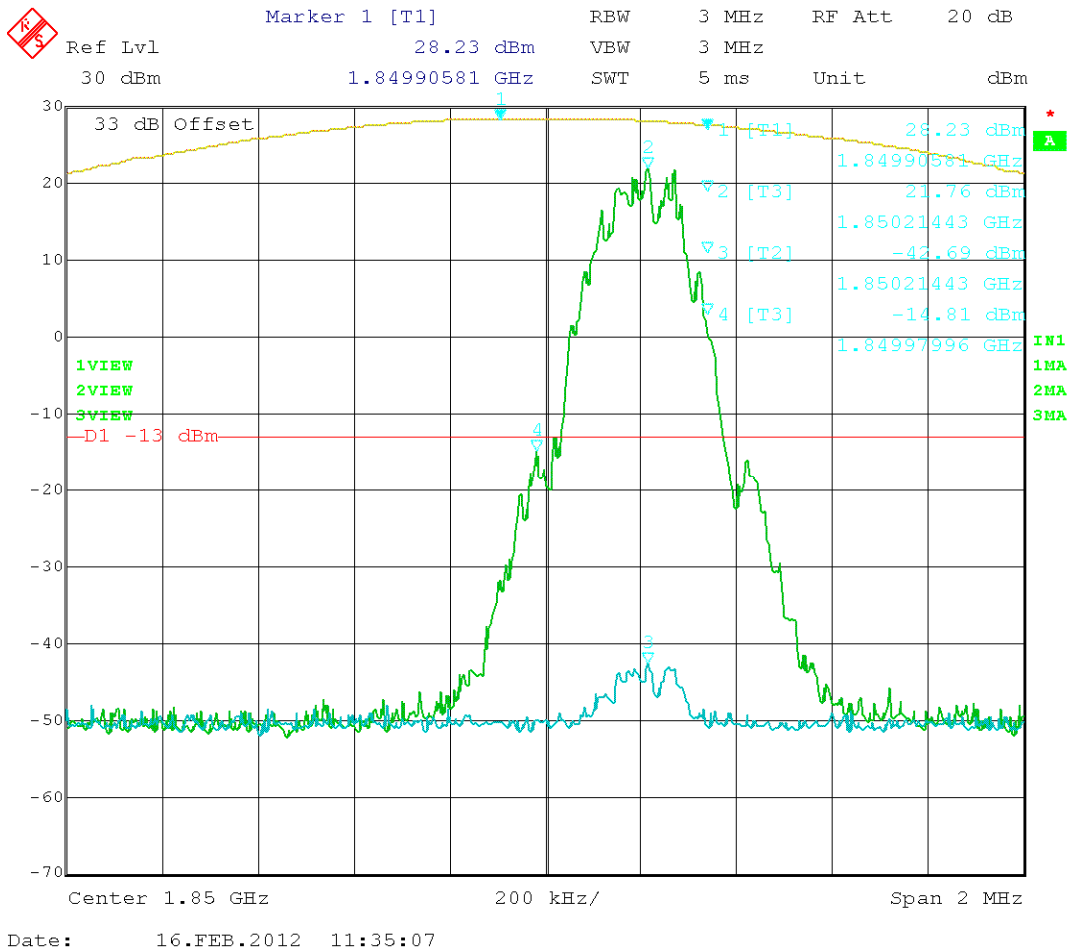

Figure 13: GSM – In vs. Out 1850.20MHz

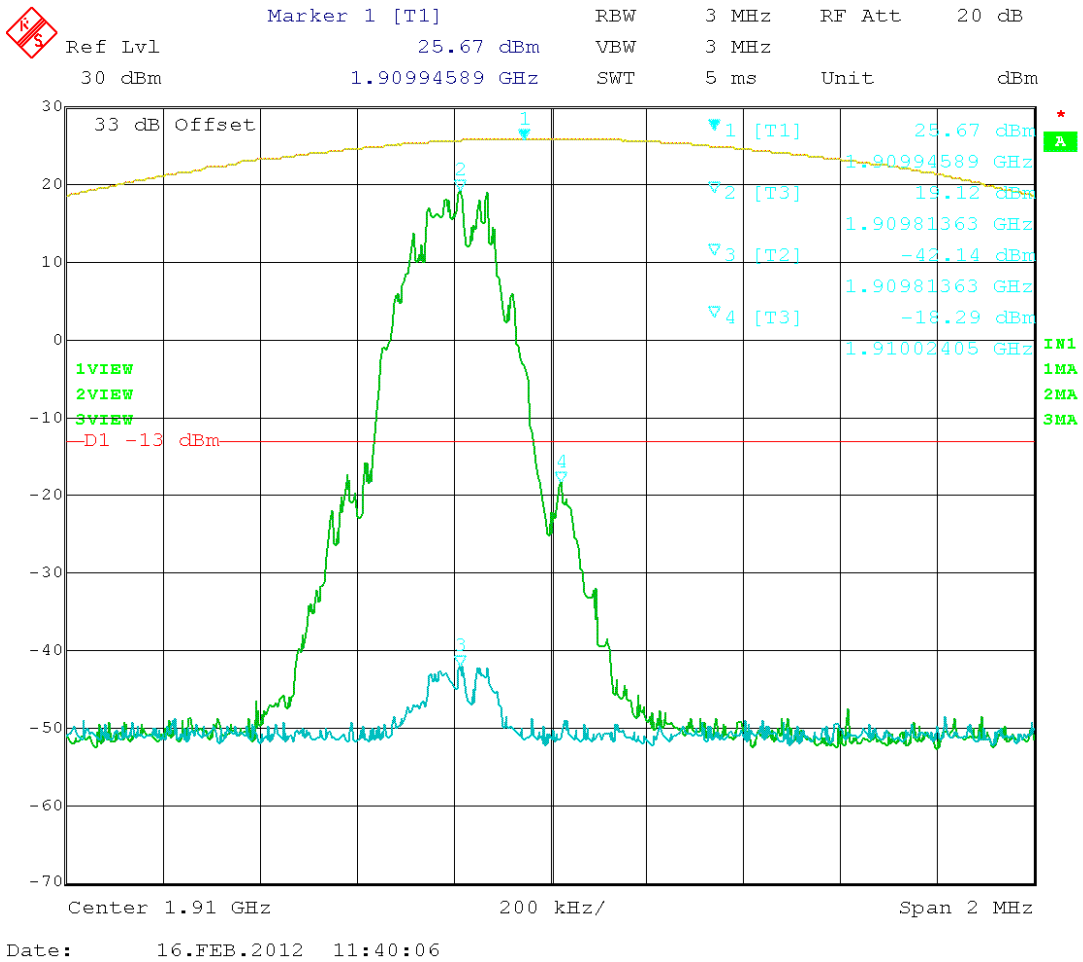

Figure 14: GSM – In vs. Out 1909.80MHz

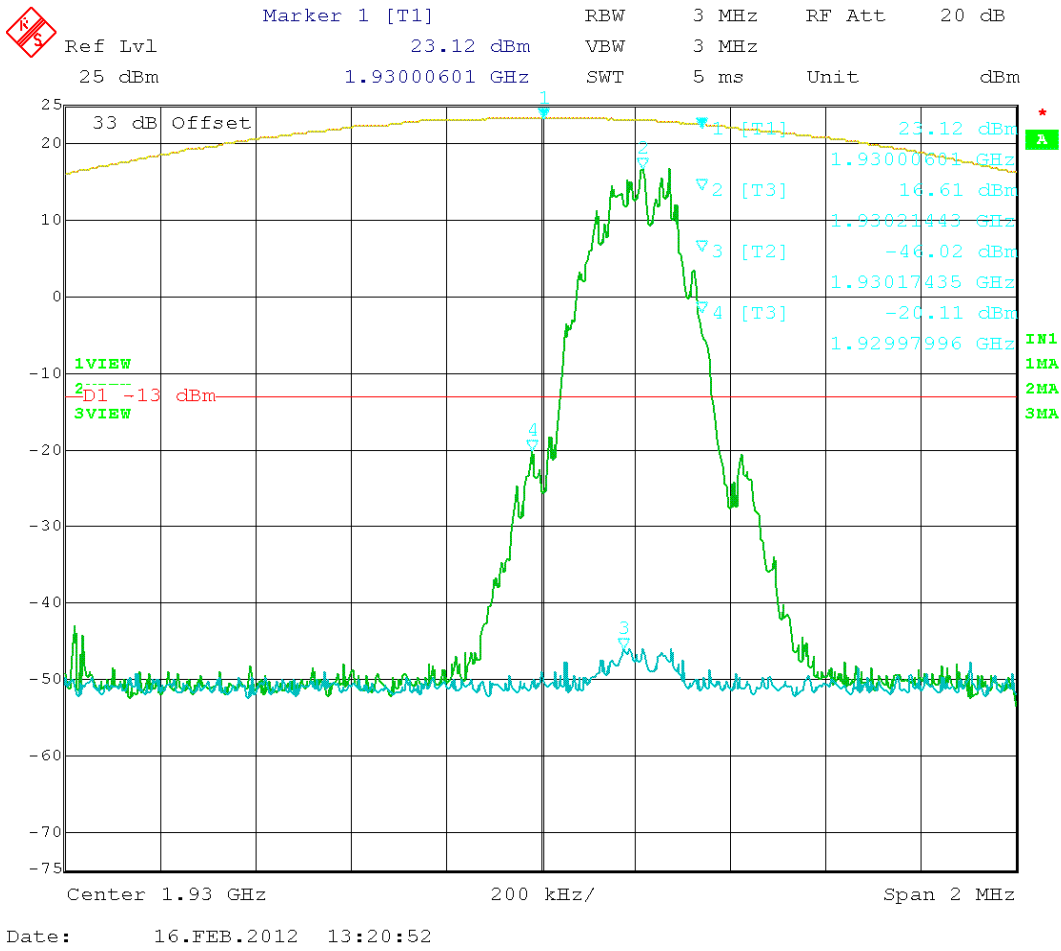

Figure 15: GSM – In vs. Out 1930.20MHz

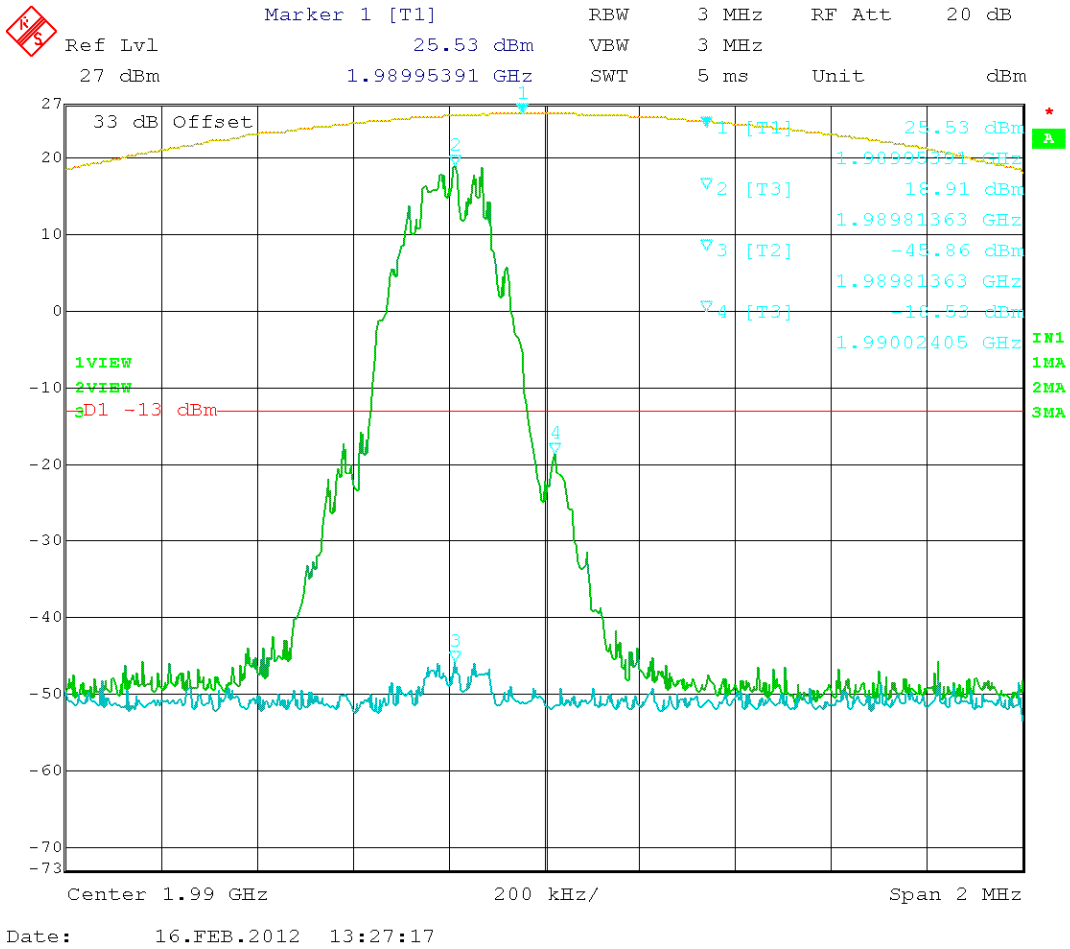

Figure 16: GSM – In vs. Out 1989.80MHz

Compensating for RBW (1%) using $10 \log(12.5/3) = 6.2$ dB we get the following amplitudes at the bandedge:

Test Data Table 17 – CDMA 800 – Uplink/Downlink

Channel (MHz)	Bandedge Frequency (MHz)	Amplitude level at the band-edge (dBm)	Limit (dBm)	Margin (dB)
825.25	823.96	-18.73	-13	5.73
847.75	849.03	-20.99	-13	7.99
870.25	868.89	-33.14	-13	20.14
892.75	894.03	-32.54	-13	19.54

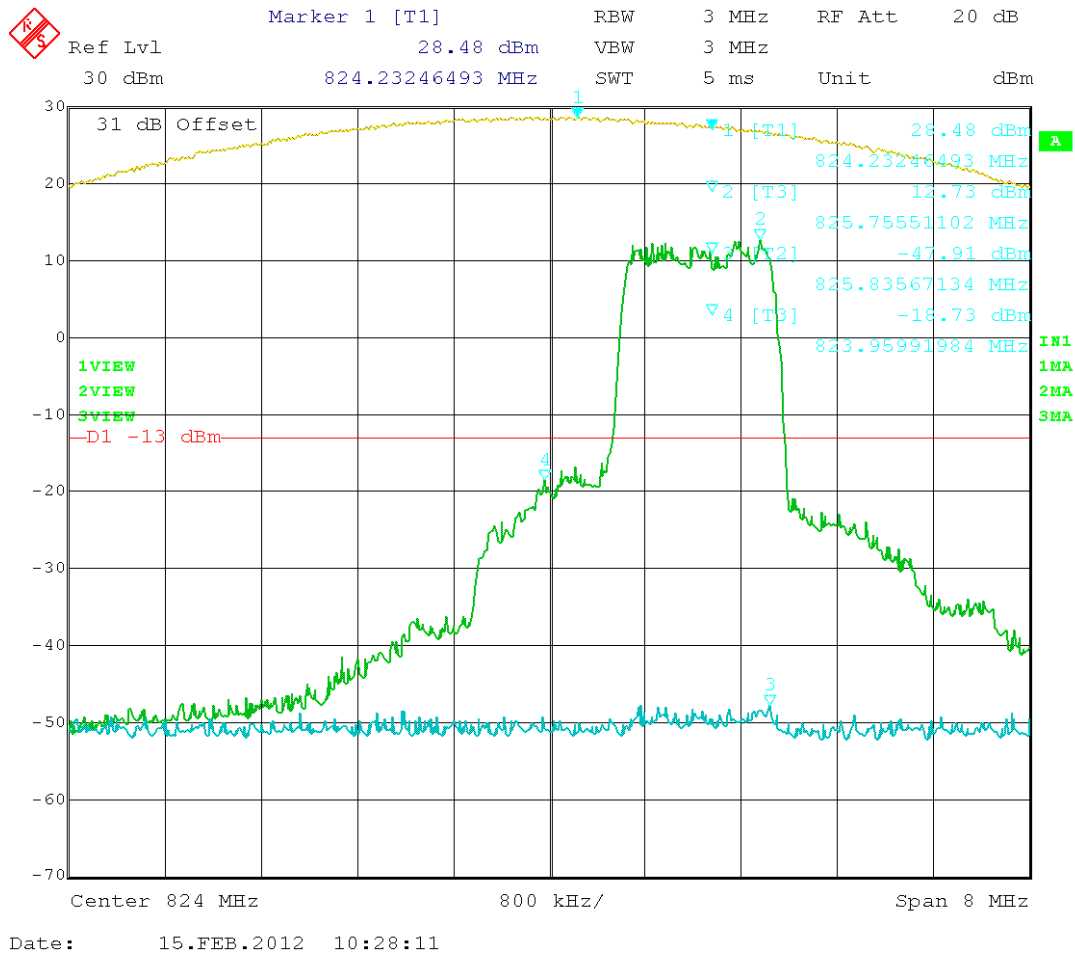

Figure 17: CDMA – In vs. Out 825.25MHz

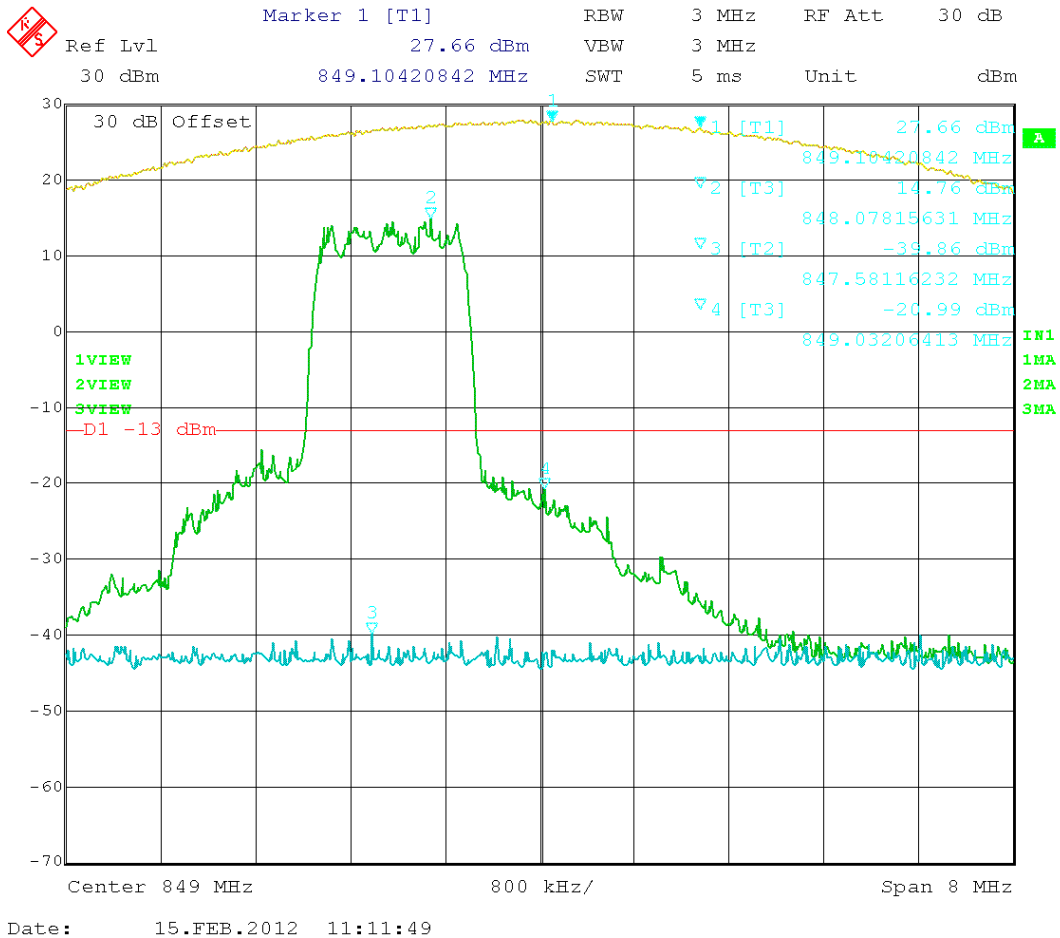
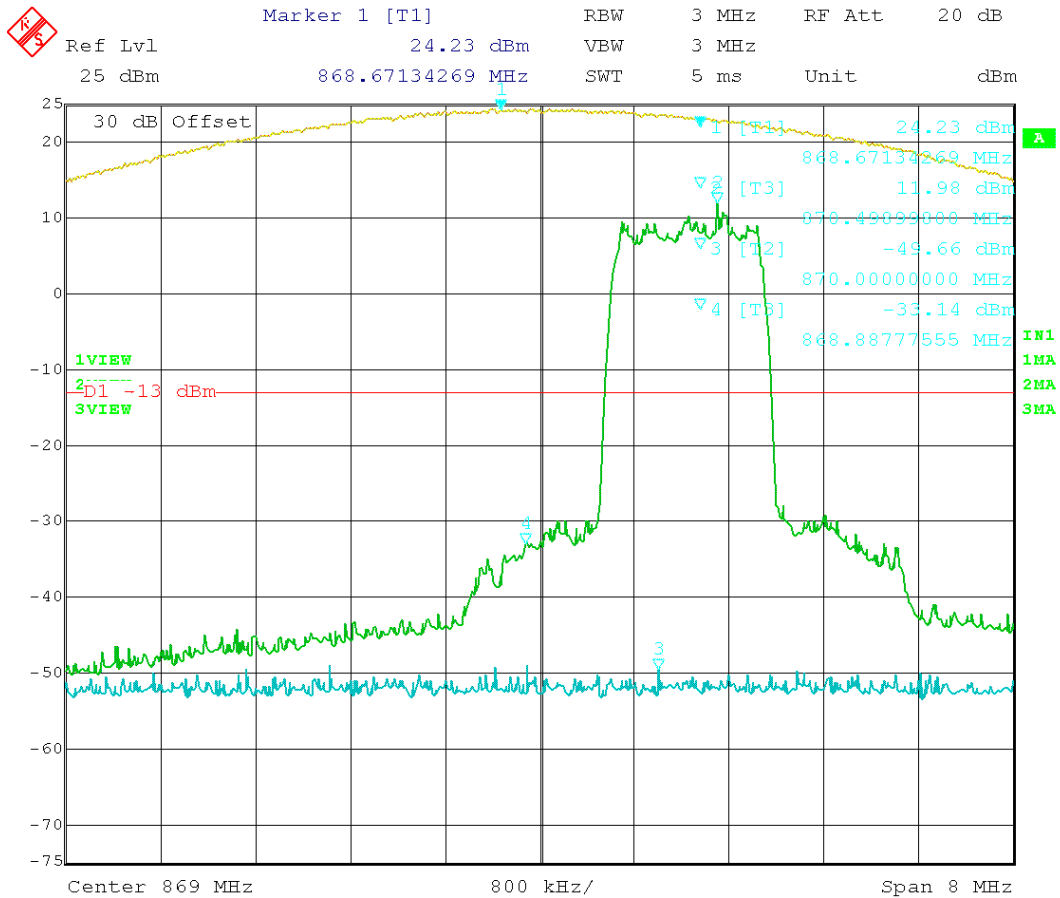

Figure 18: CDMA – In vs. Out 847.75 MHz



Date: 15.FEB.2012 11:23:22

Figure 19: CDMA – In vs. Out 870.25 MHz

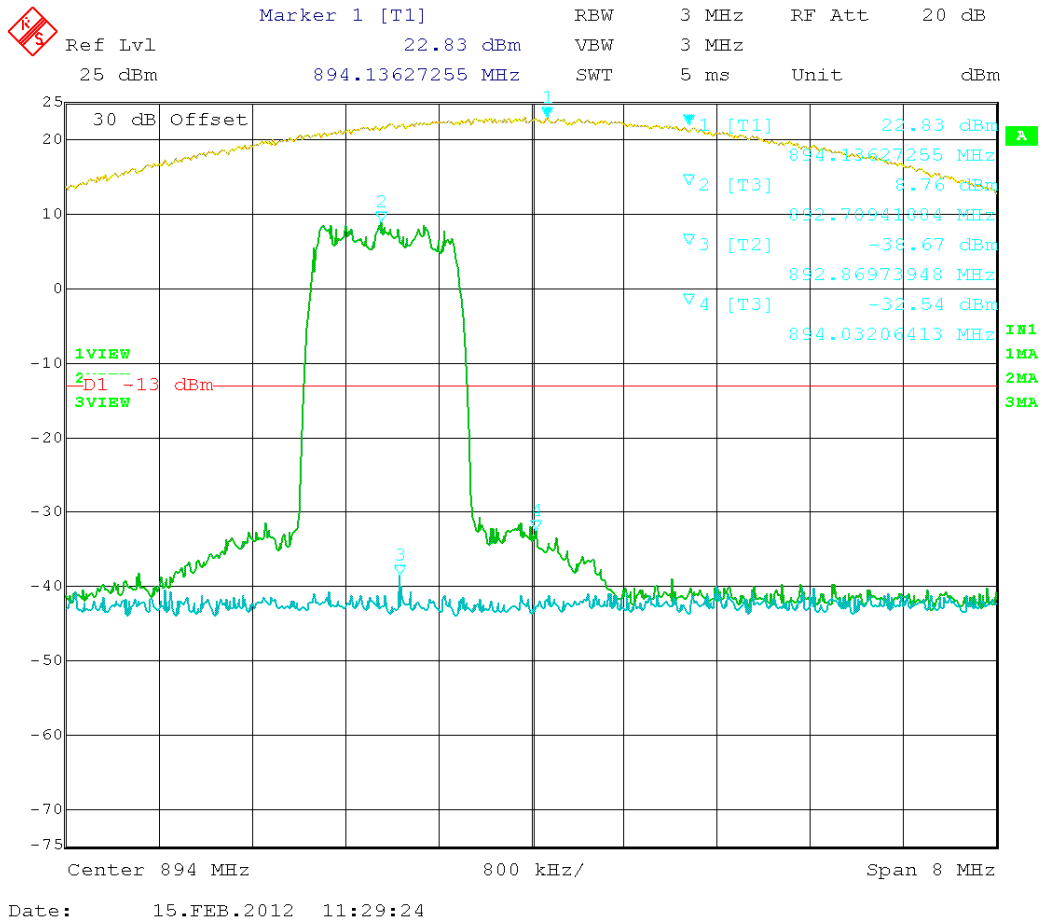

Figure 20: CDMA – In vs. Out 892.75 MHz

Test Data Table 18 – WCDMA 800 – Uplink/Downlink

Channel (MHz)	Bandedge Frequency (MHz)	Amplitude level at the band-edge (dBm)	Limit (dBm)	Margin (dB)
826.50	823.88	-19.76	-13	6.76
846.50	849.24	-19.79	-13	6.79
871.50	868.96	-36.25	-13	23.25
891.50	894.44	-34.13	-13	21.13

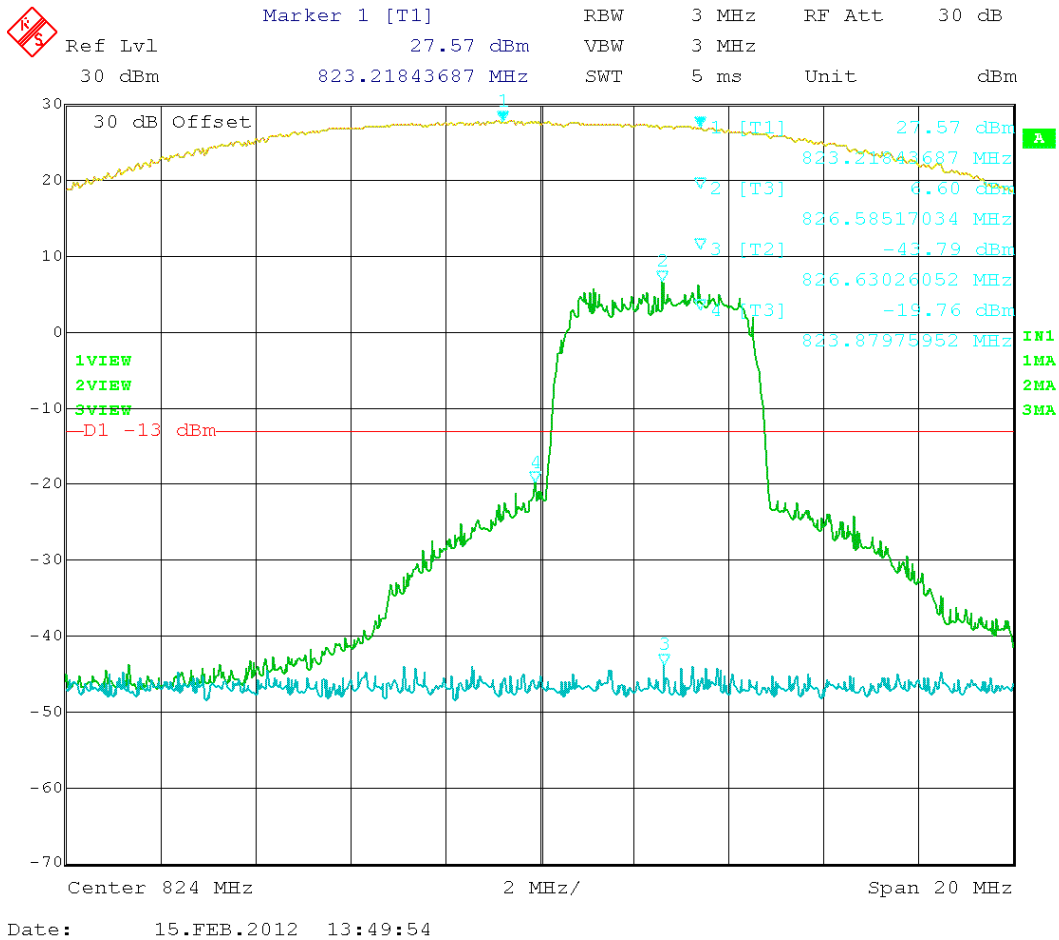

Figure 21: WCDMA – In vs. Out 826.50 MHz

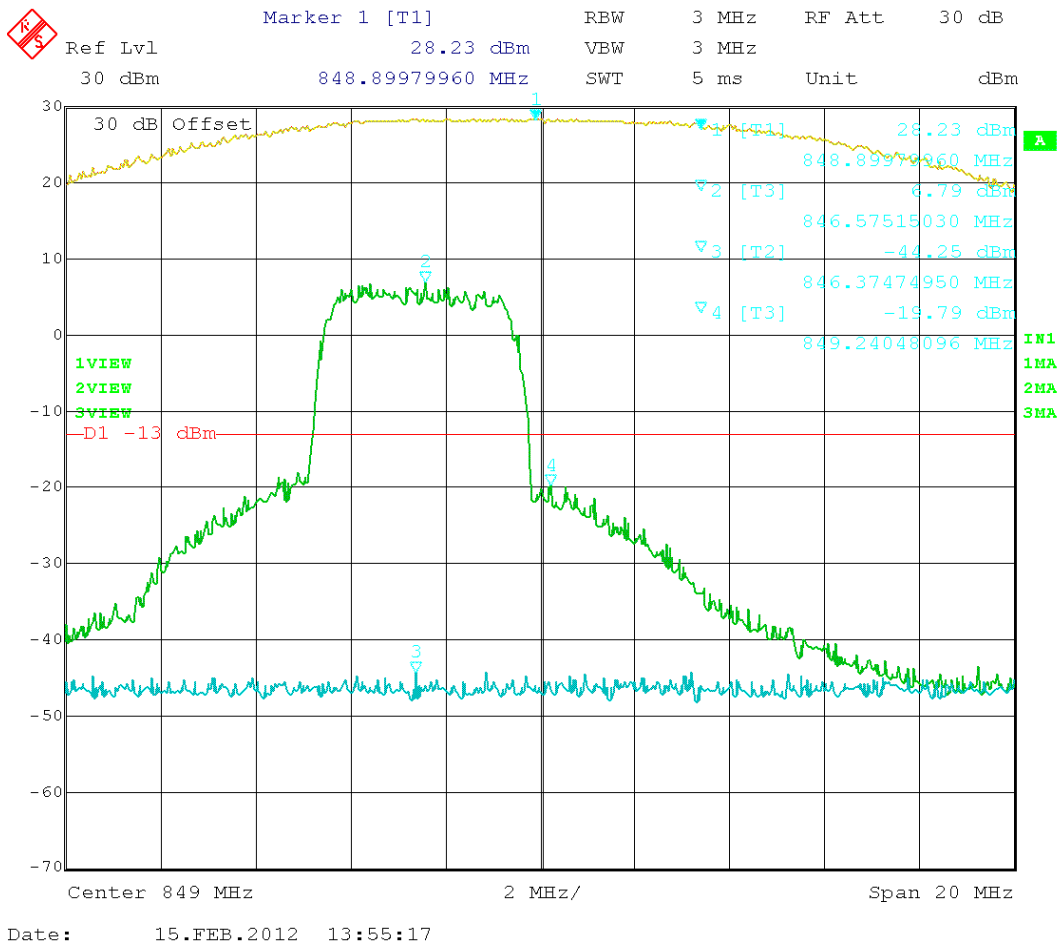

Figure 22: WCDMA – In vs. Out 846.50 MHz

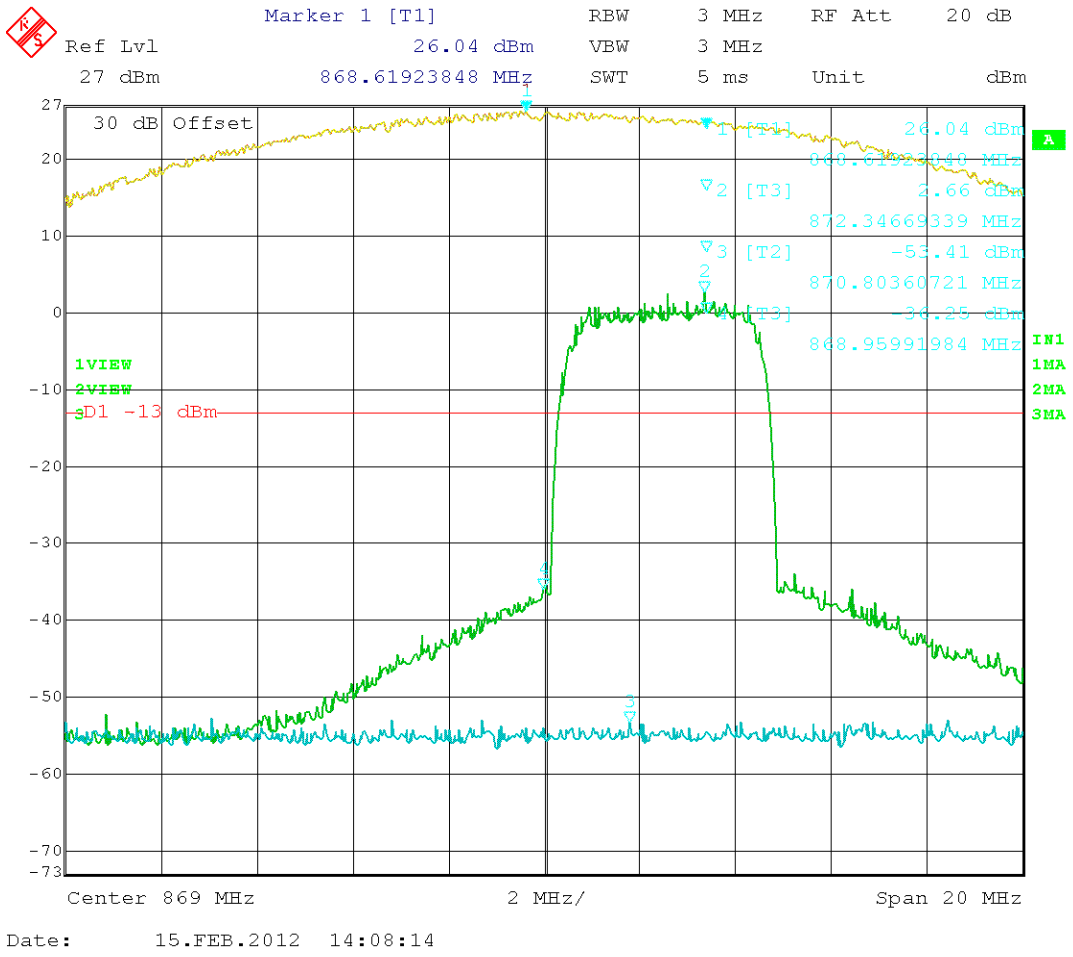

Figure 23: WCDMA – In vs. Out 871.50 MHz

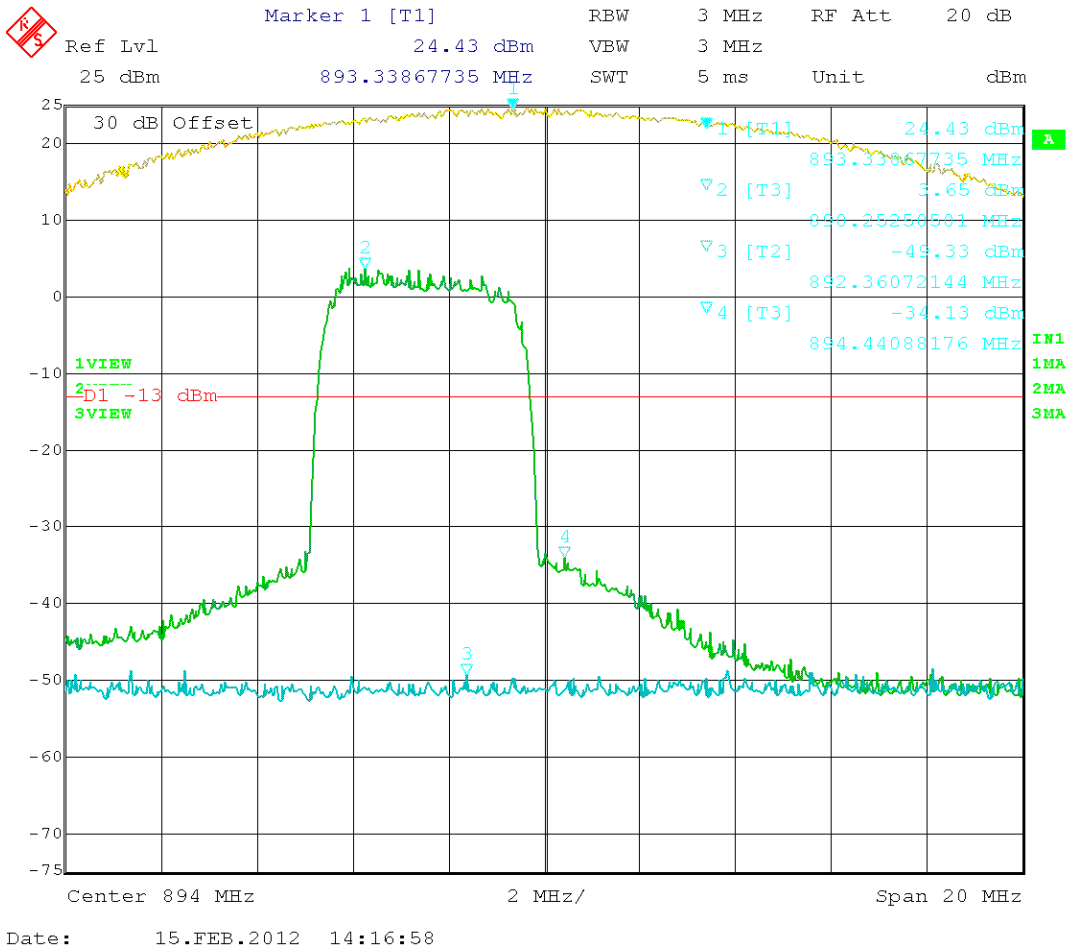

Figure 24: WCDMA – In vs. Out 893.50 MHz

Test Data Table 19 – LTE 800 – Uplink/Downlink

Channel (MHz)	Band-edge Frequency (MHz)	Amplitude level at the band-edge (dBm)	Limit (dBm)	Margin (dB)
829.00	822.88	-25.83	-13	12.83
844.00	850.19	-26.57	-13	13.57
874.00	868.37	-27.97	-13	14.97
889.00	894.21	-31.50	-13	18.5

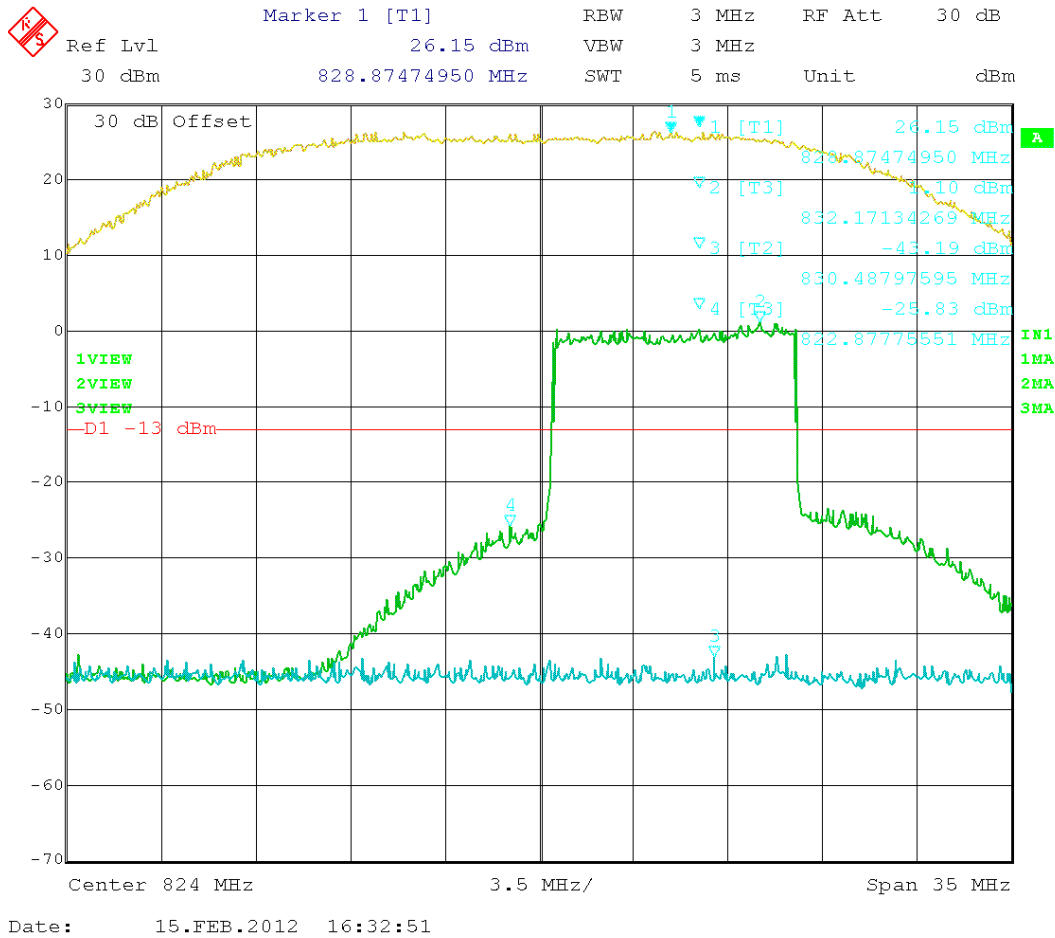

Figure 25: LTE – In vs. Out 829.00 MHz

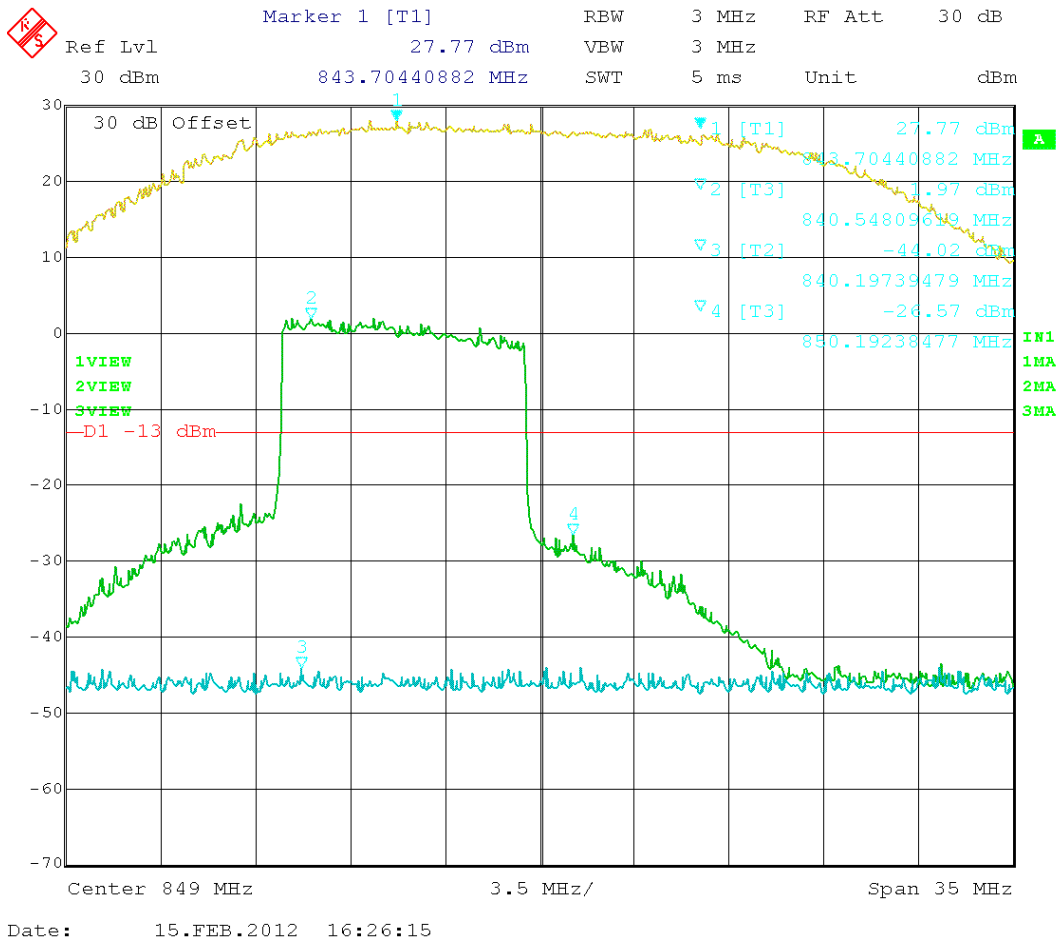

Figure 26: LTE – In vs. Out 844.00 MHz

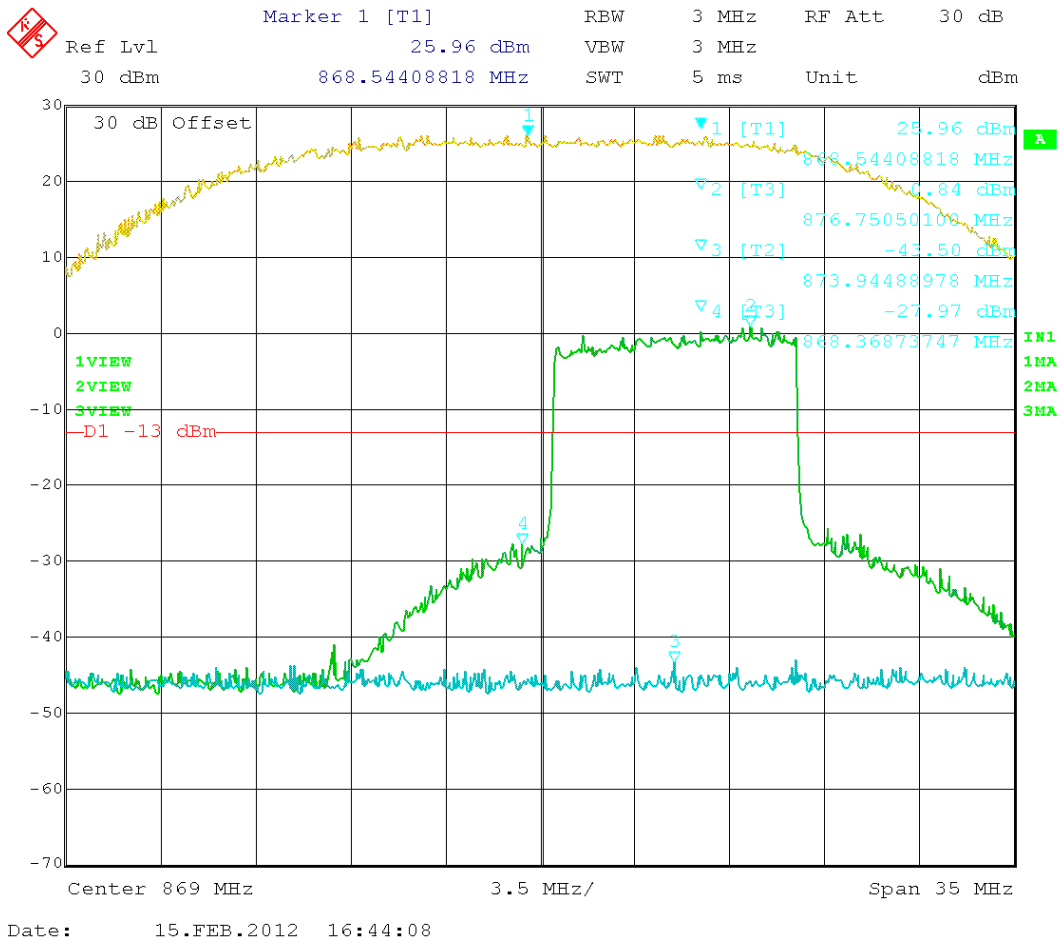

Figure 27: LTE – In vs. Out 874.00 MHz

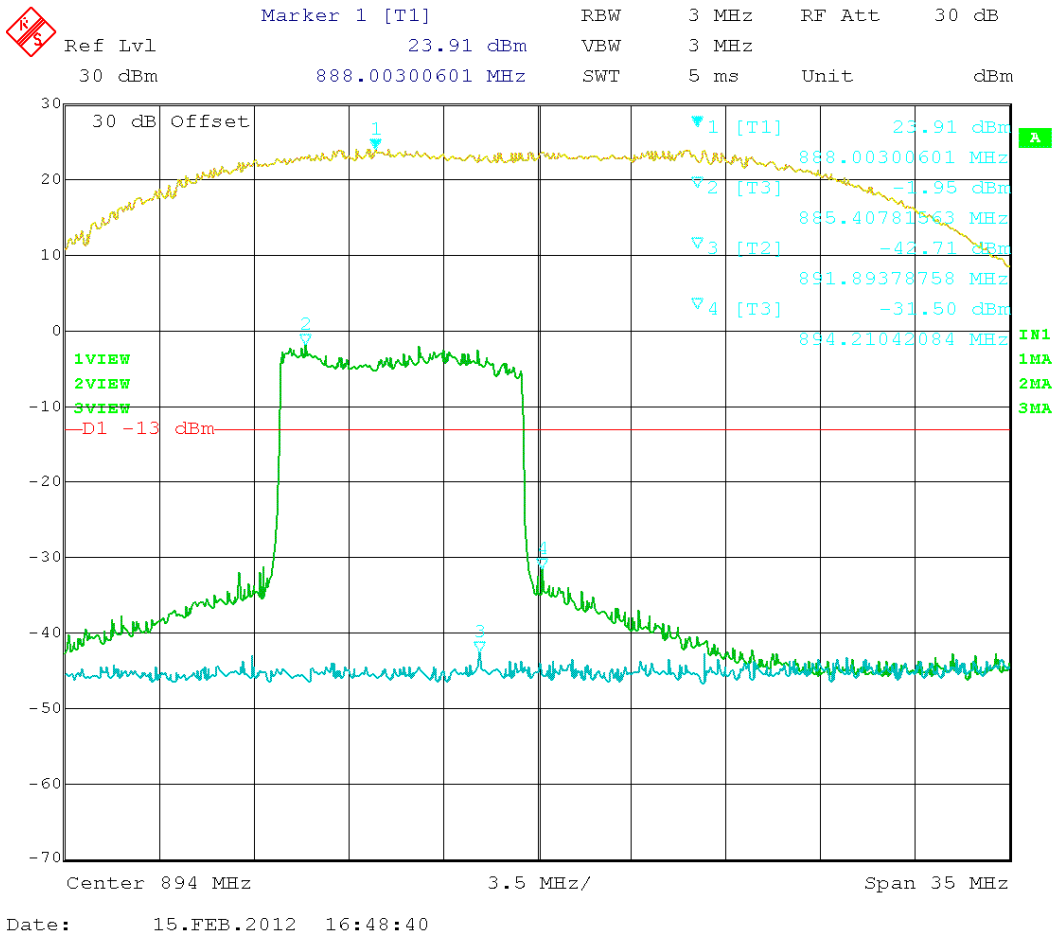

Figure 28: LTE – In vs. Out 889.00 MHz

Test Data Table 20 – EDGE 800 – Uplink/Downlink

Channel (MHz)	Band-edge Frequency (MHz)	Amplitude level at the band-edge (dBm)	Limit (dBm)	Margin (dB)
824.2	823.99	-19.73	-13	6.73
848.8	849.02	-23.22	-13	10.22
869.2	868.98	-24.88	-13	11.88
893.8	894.02	-27.76	-13	14.76

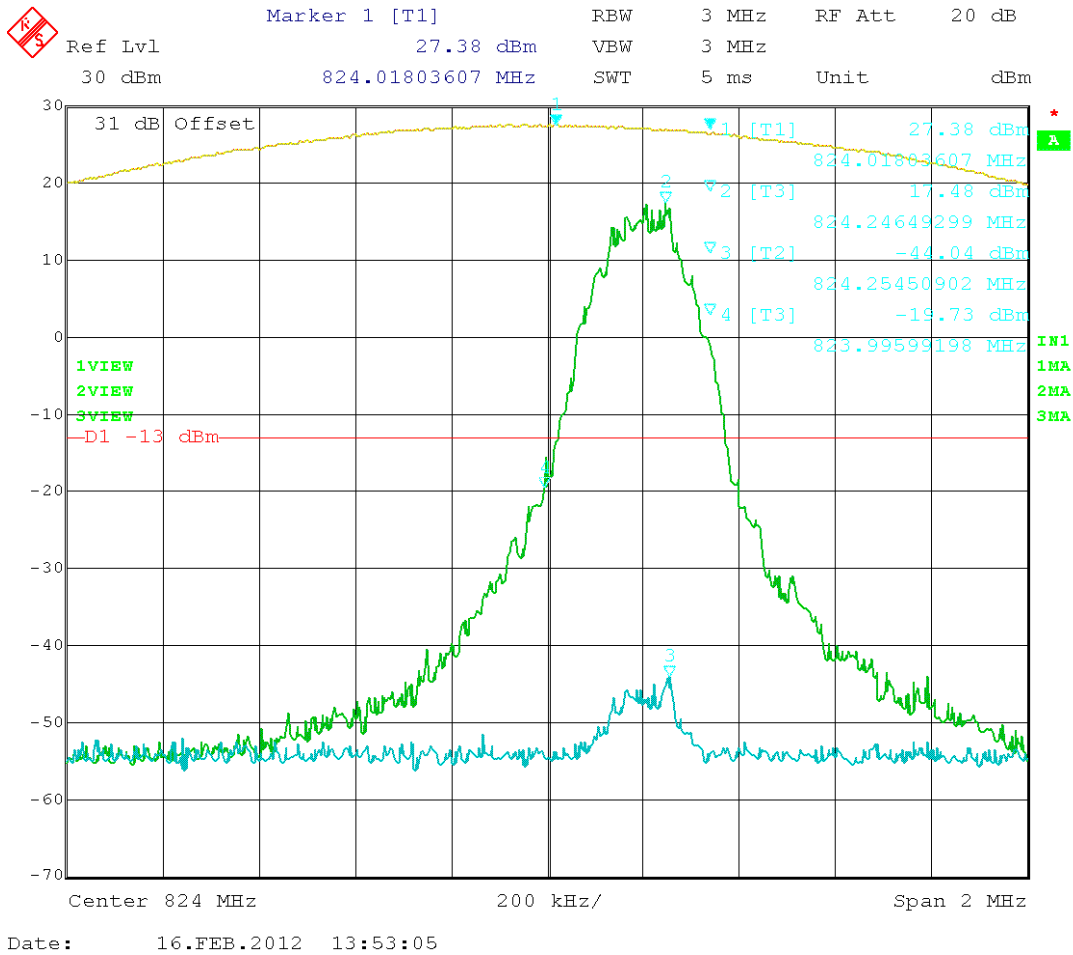

Figure 25: EDGE – In vs. Out 824.20 MHz

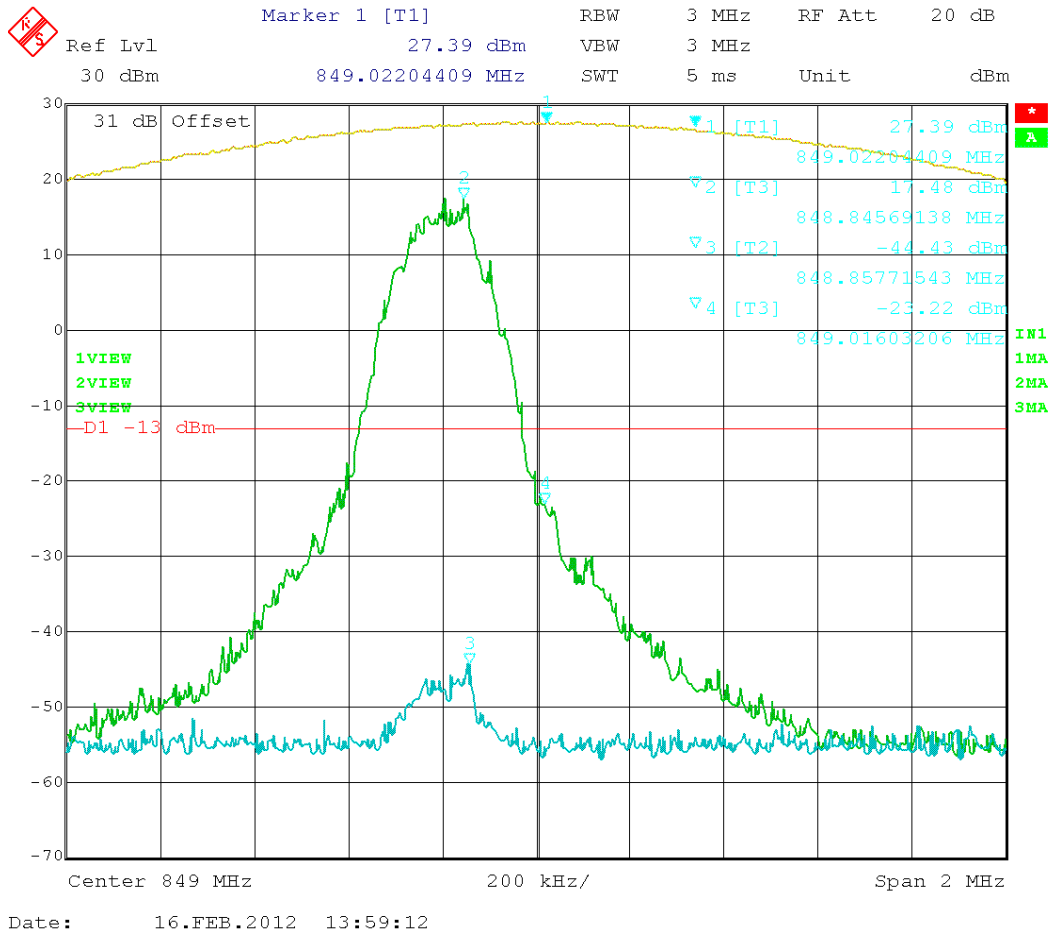

Figure 26: EDGE – In vs. Out 848.80 MHz

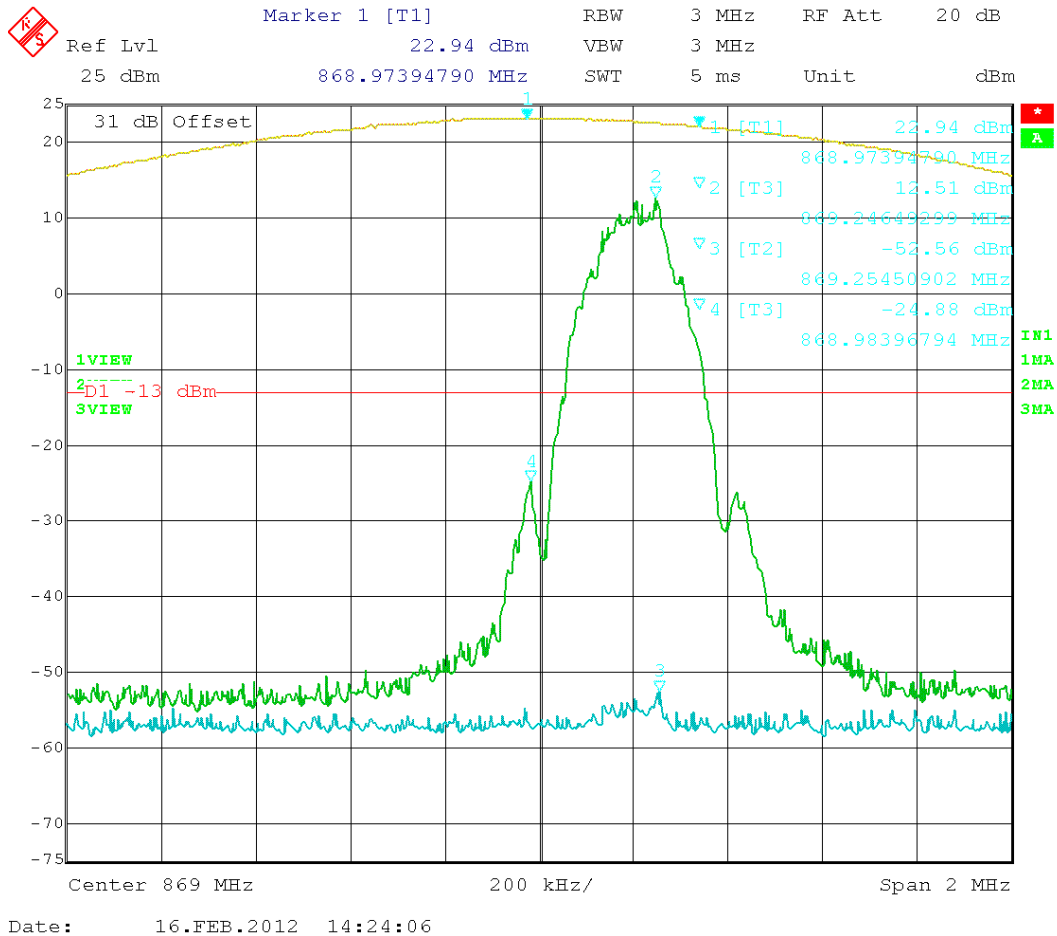
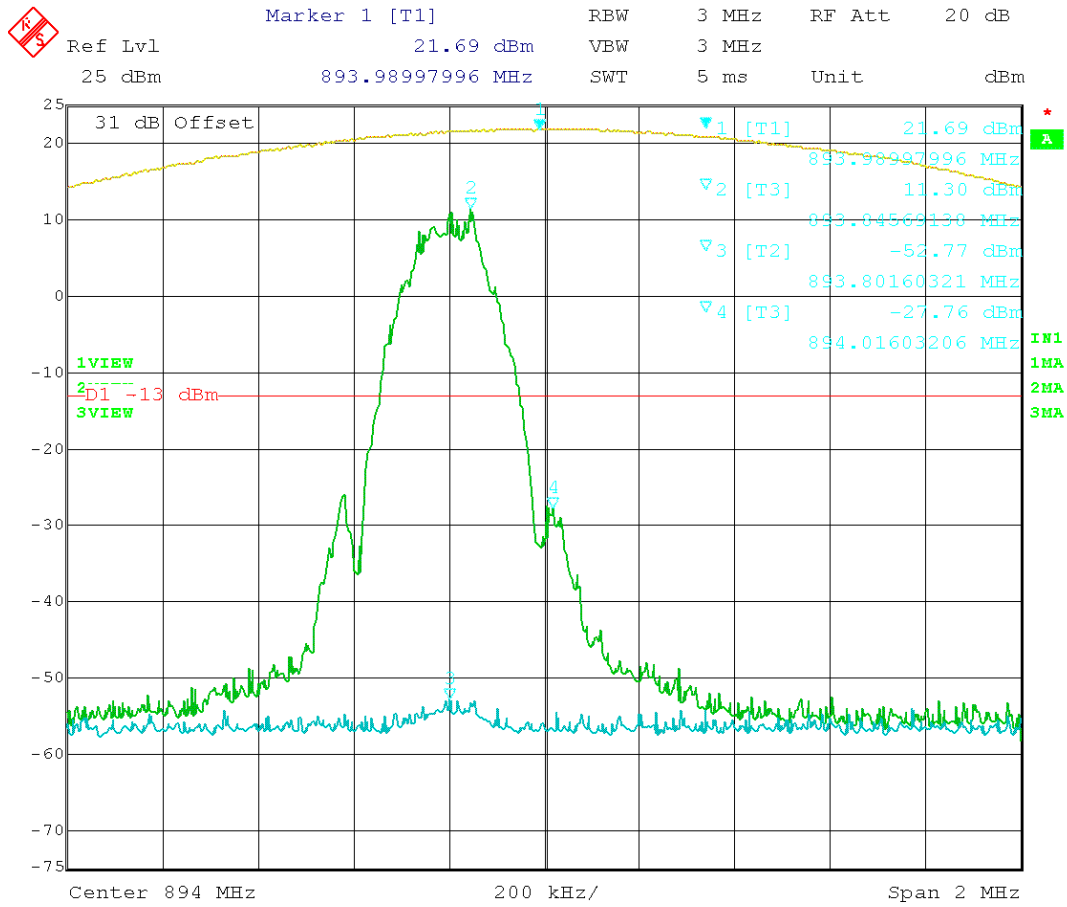

Figure 27: EDGE – In vs. Out 869.20 MHz



Date: 16.FEB.2012 14:32:12

Figure 28: EDGE - In vs. Out 893.80 MHz

Test Data Table 21 – GSM 800 – Uplink/Downlink

Channel (MHz)	Band-edge Frequency (MHz)	Amplitude level at the band-edge (dBm)	Limit (dBm)	Margin (dB)
			-13	
			-13	
			-13	
			-13	

The Reference level on the following plots was calibrated using a 3MHz RBW=VBW.

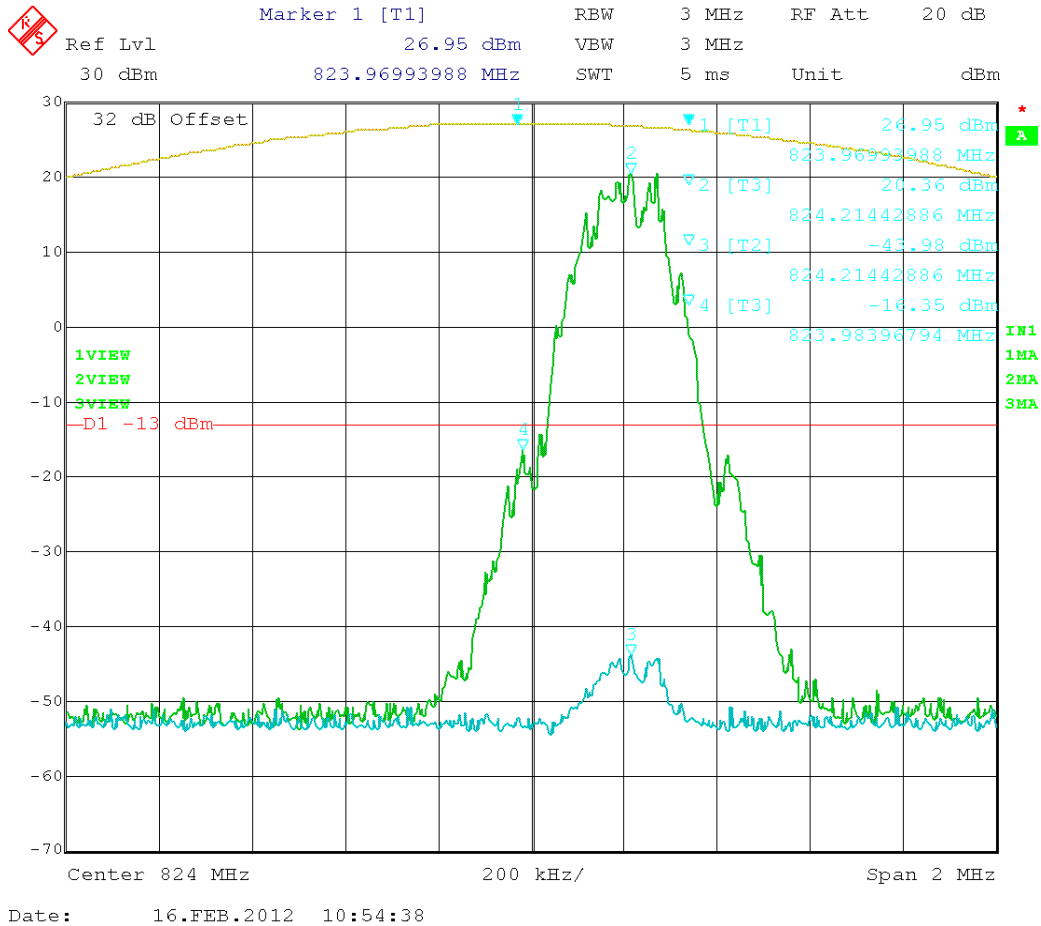

Figure 29: GSM – In vs. Out 824.2 MHz

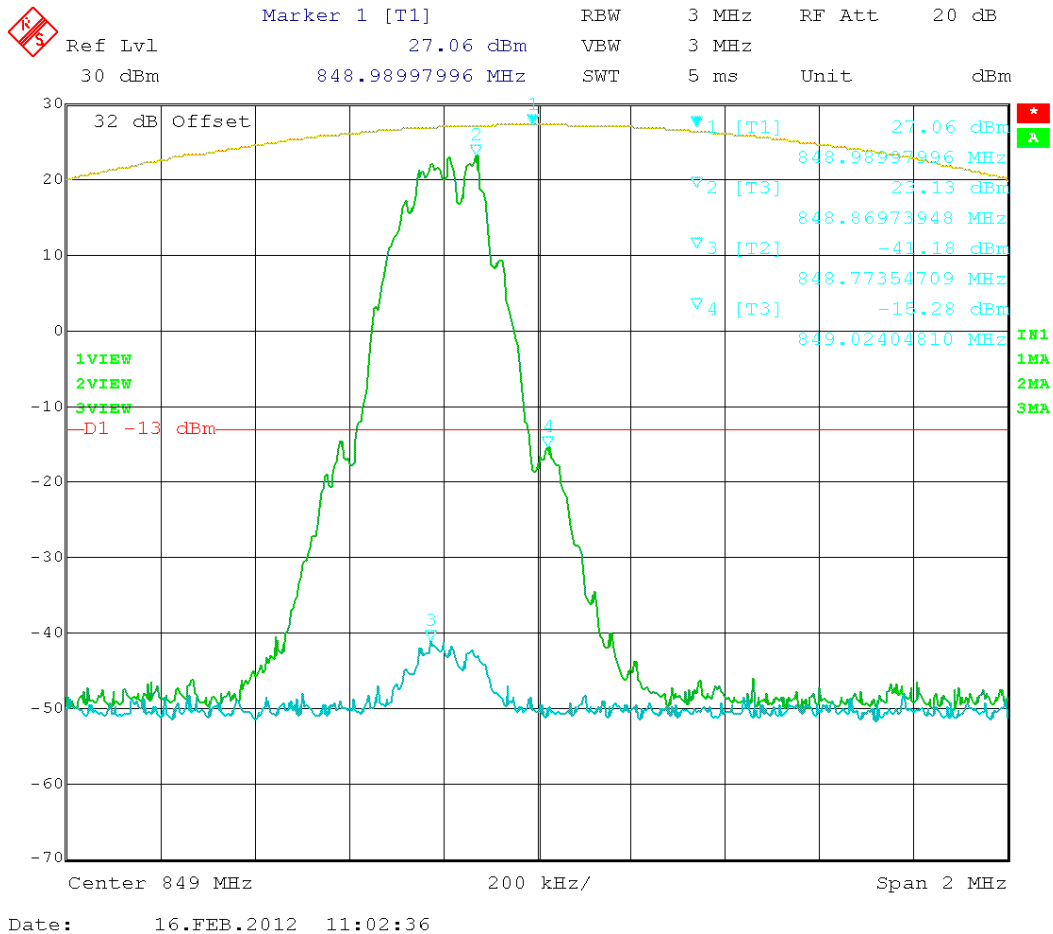

Figure 30: GSM – In vs. Out 848.8 MHz

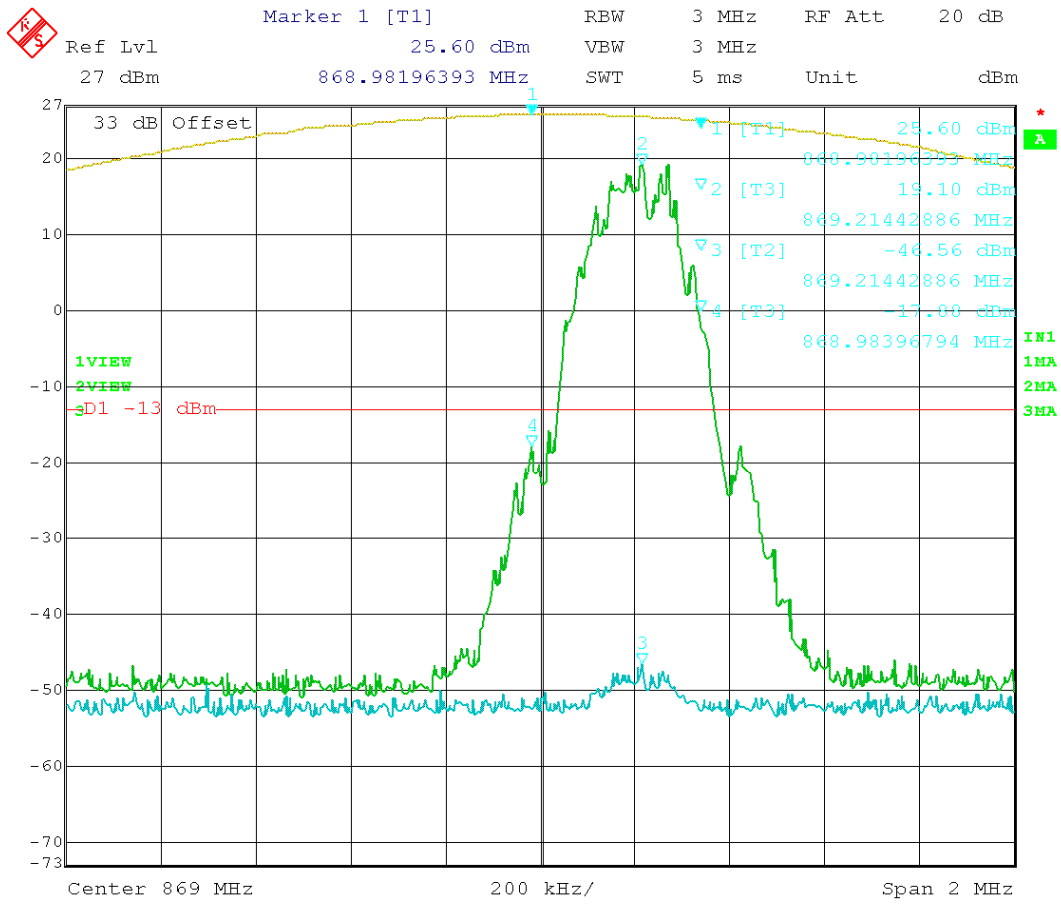

Figure 31: GSM – In vs. Out 869.2MHz

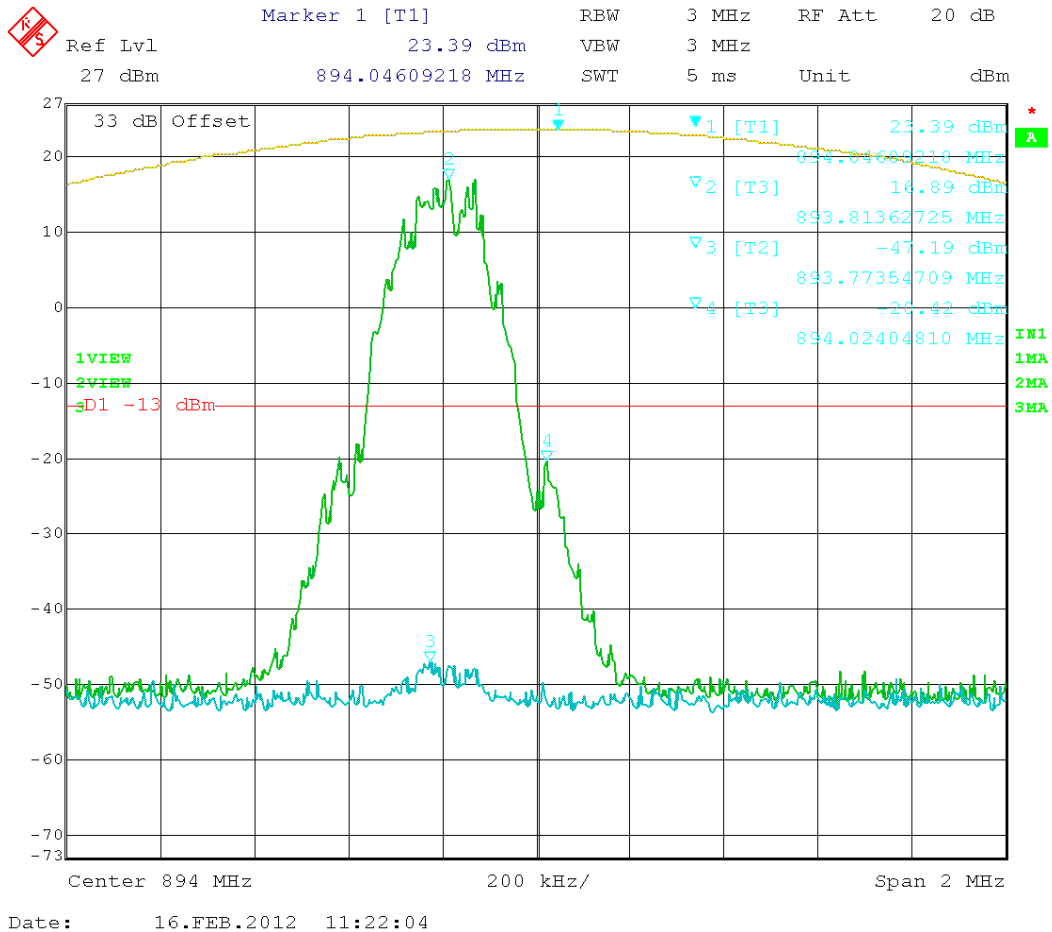
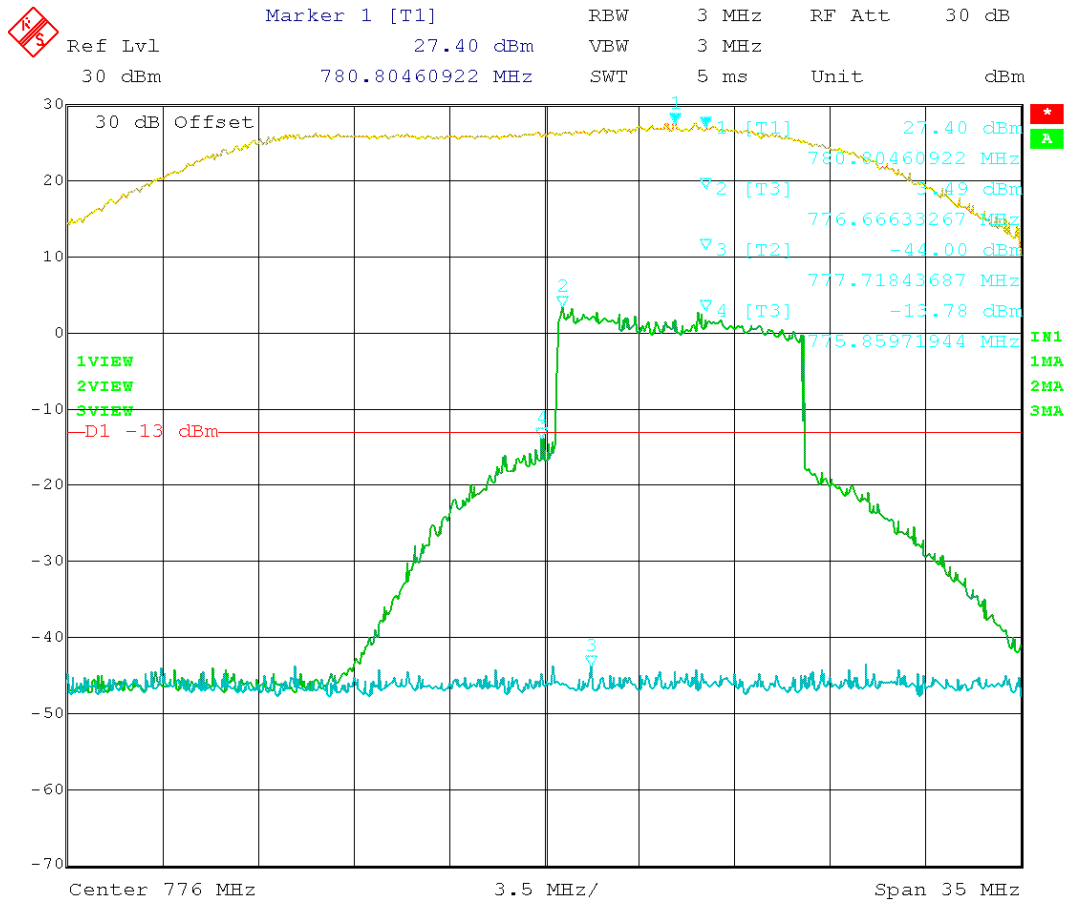

Figure 32: GSM – In vs. Out 893.8MHz

Test Data Table 22 – LTE 700 – Uplink/Downlink

Channel (MHz)	Band-edge Frequency (MHz)	Amplitude level at the band-edge (dBm)	Limit (dBm)	Margin (dB)
781.0	775.86	-13.78	-13	0.78
782.0	787.63	-18.58	-13	5.58
751.0	745.72	-31.81	-13	18.81
752.0	757.77	-30.78	-13	17.78



Date: 16.FEB.2012 08:51:29

Figure 36: LTE – In vs. Out 781.0 MHz

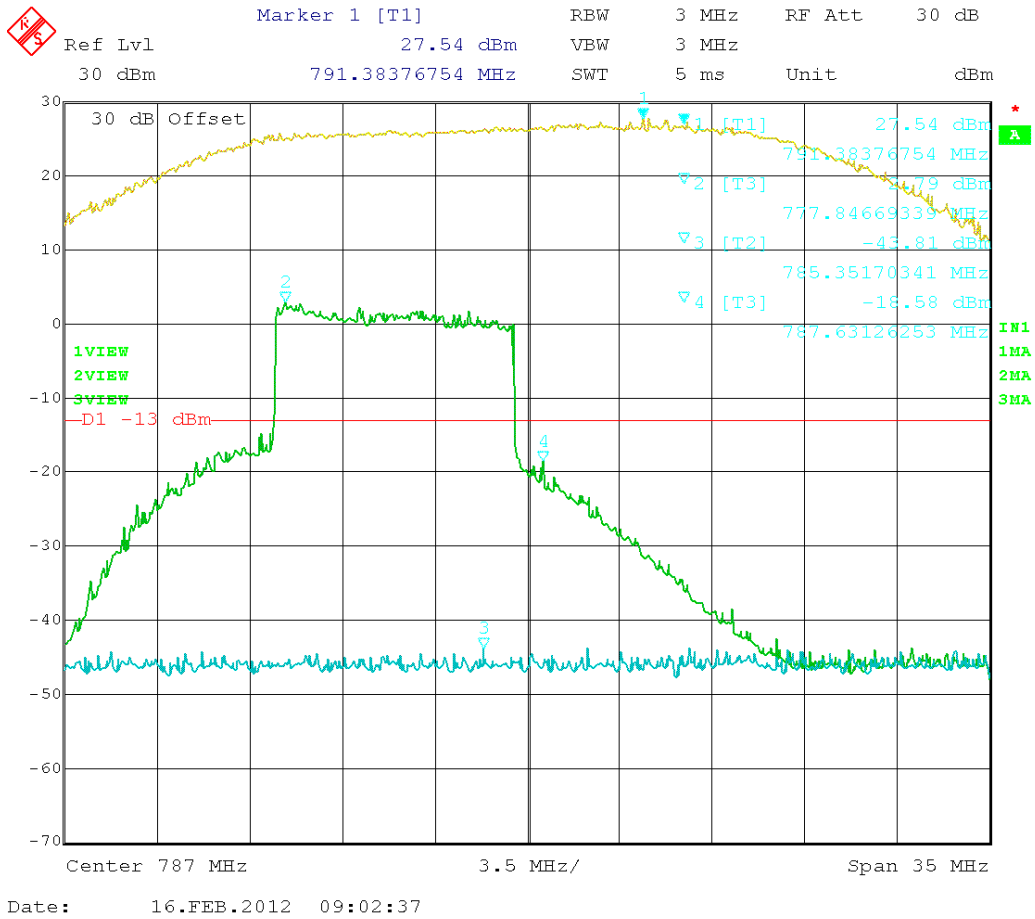

Figure 36: LTE – In vs. Out 782.0 MHz

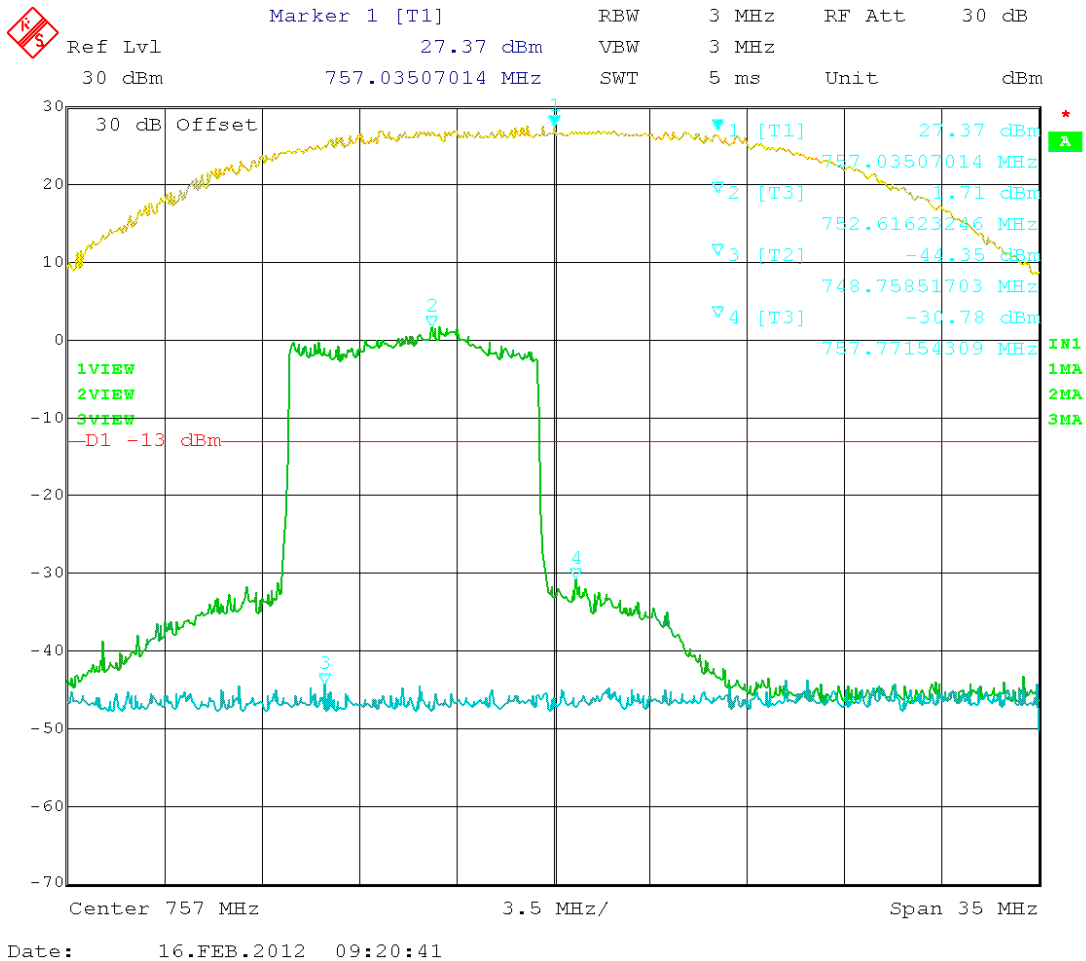

Figure 36: LTE – In vs. Out 752.0 MHz



INTERMODULATION PRODUCT SPURIOUS EMISSIONS

Rule Parts No.: Pt 2.1051

Requirements: Emissions must be $43 + 10 \log (P_o)$ dB below the mean power output of the transmitter or below the -13dBm

All the modulation types were tested using the three tone test method. A CW signal was use instead of GSM, EDGE, and F1D modulations. EDGE and GSM provided the same test results and only GSM data are presented in this report. The input power to the amplifier was set at maximum drive level by combining the three tones. The three tones were chosen in such a way (1)the third order intermodulation product frequencies are located within the pass band of the DUT and (2) they produce the worst-case emissions out of band.

Test Data: The DUT meets the requirements.

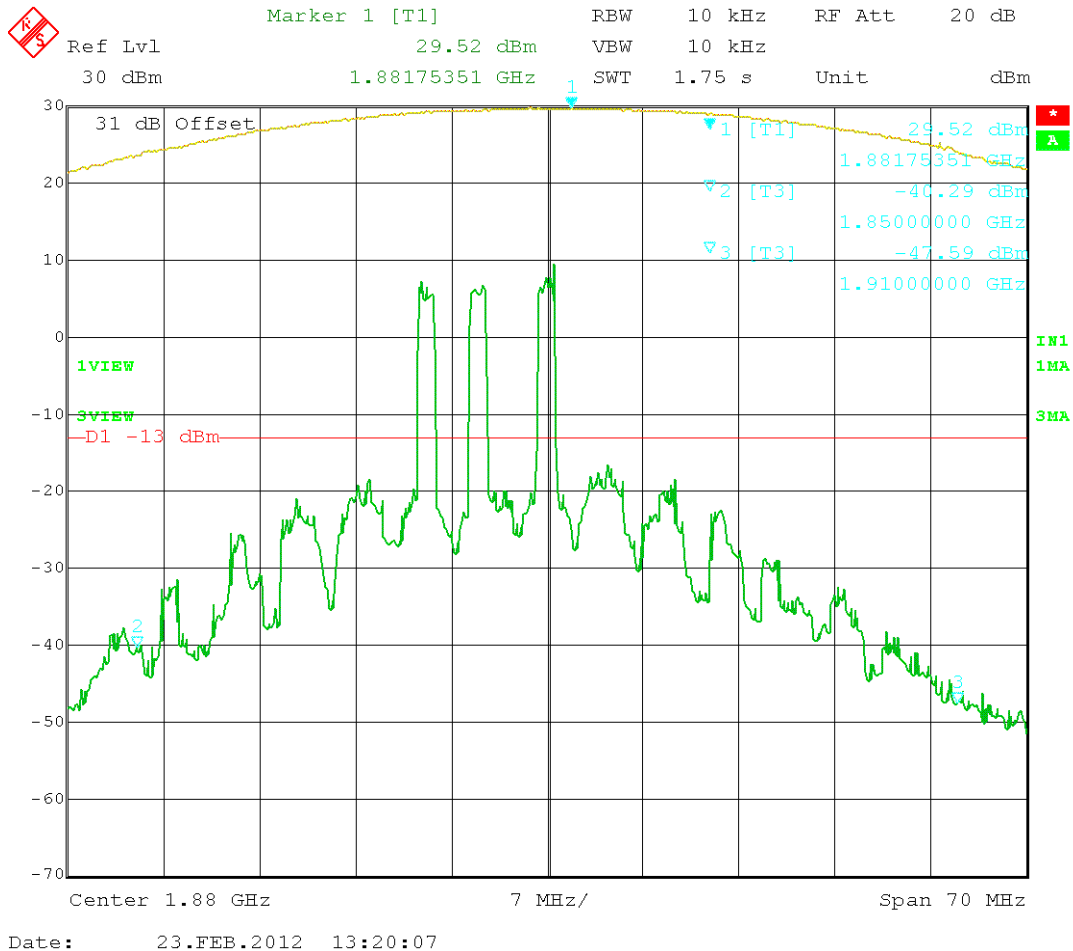

Figure 34: CDMA 3 tones intermodulation - (1850 – 1910) MHz.

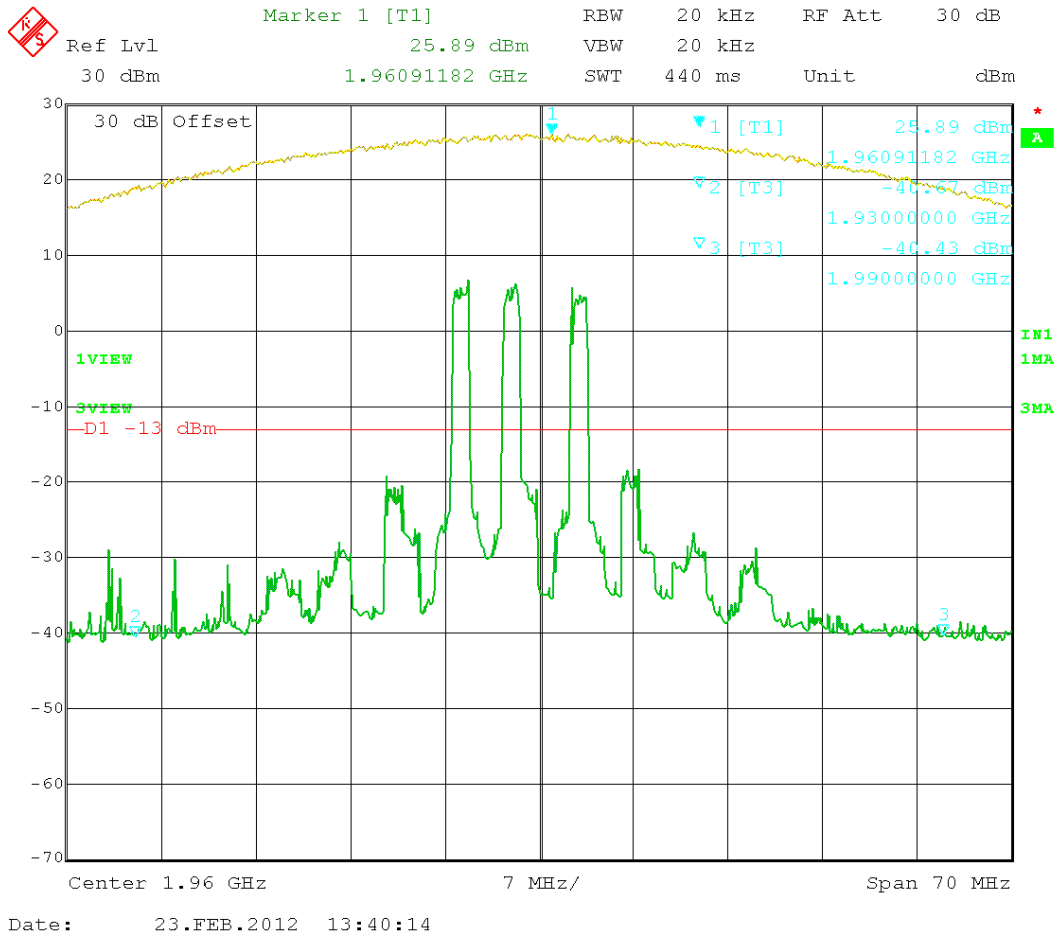
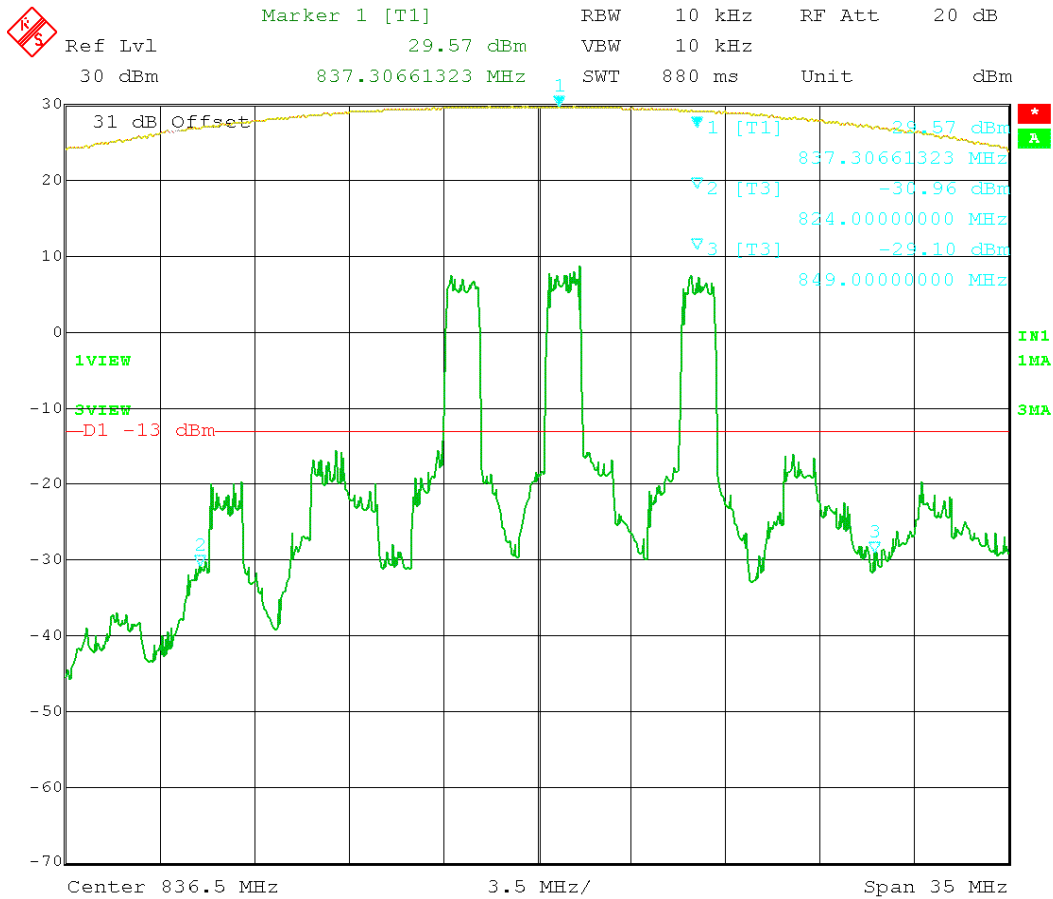

Figure 35: CDMA 3 tones intermodulation - (1930 – 1990) MHz.



Date: 23.FEB.2012 13:24:54

Figure 36: CDMA 3 tones intermodulation – (824 – 849) MHz.

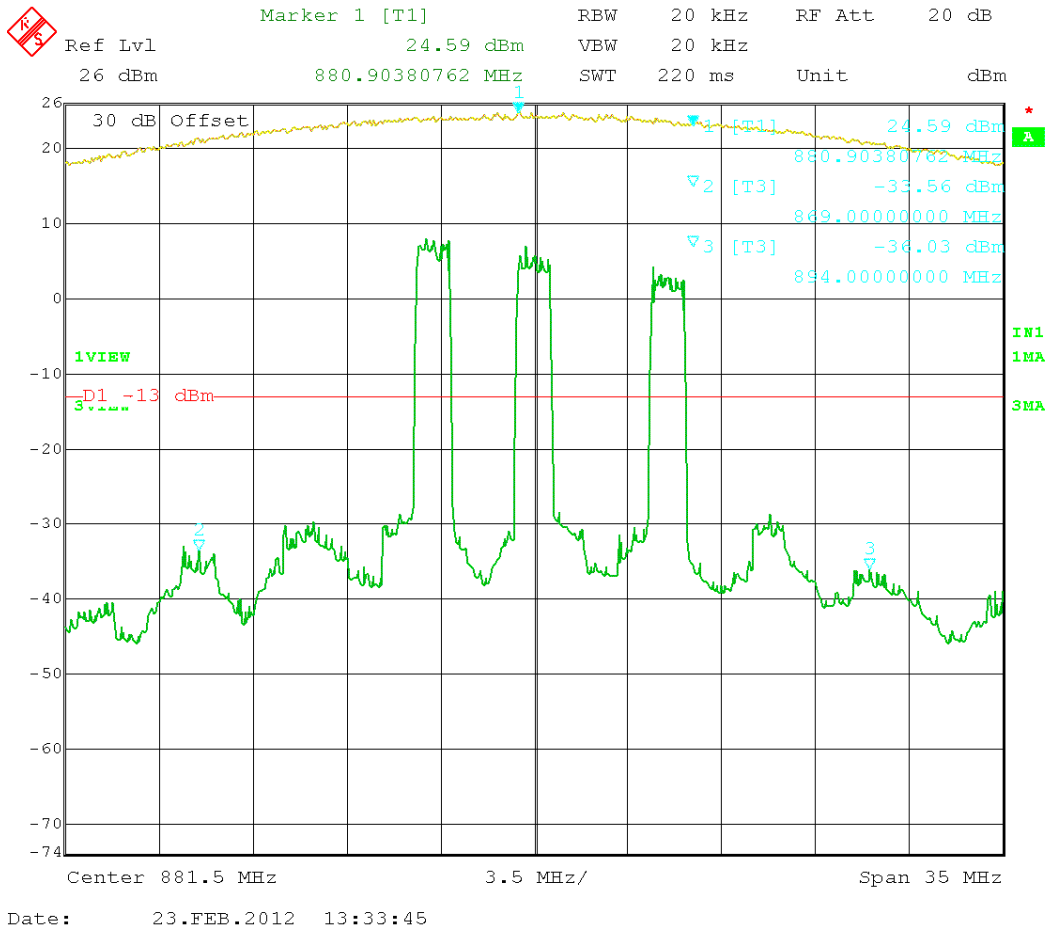
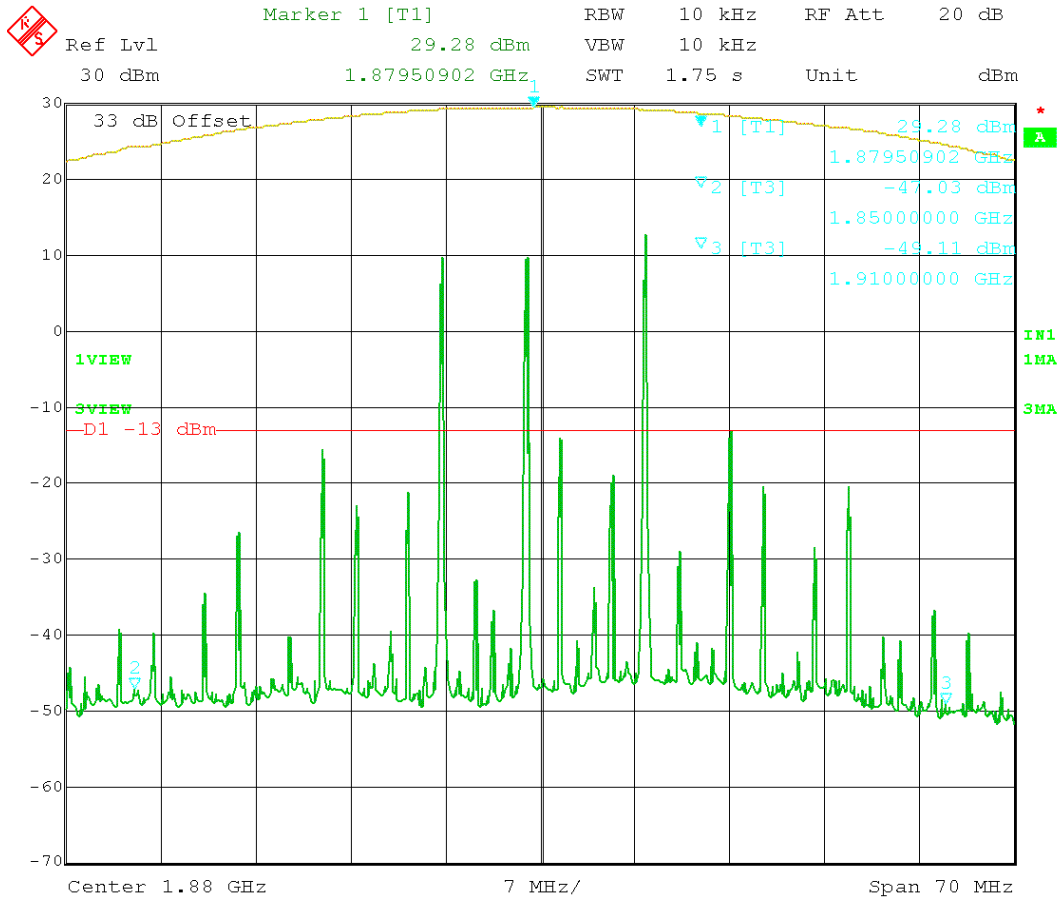

Figure 37: CDMA 3 tones intermodulation - (869 – 894) MHz.



Date: 23.FEB.2012 11:42:55

Figure 38: GSM 3 tones intermodulation - (1850 – 1910) MHz

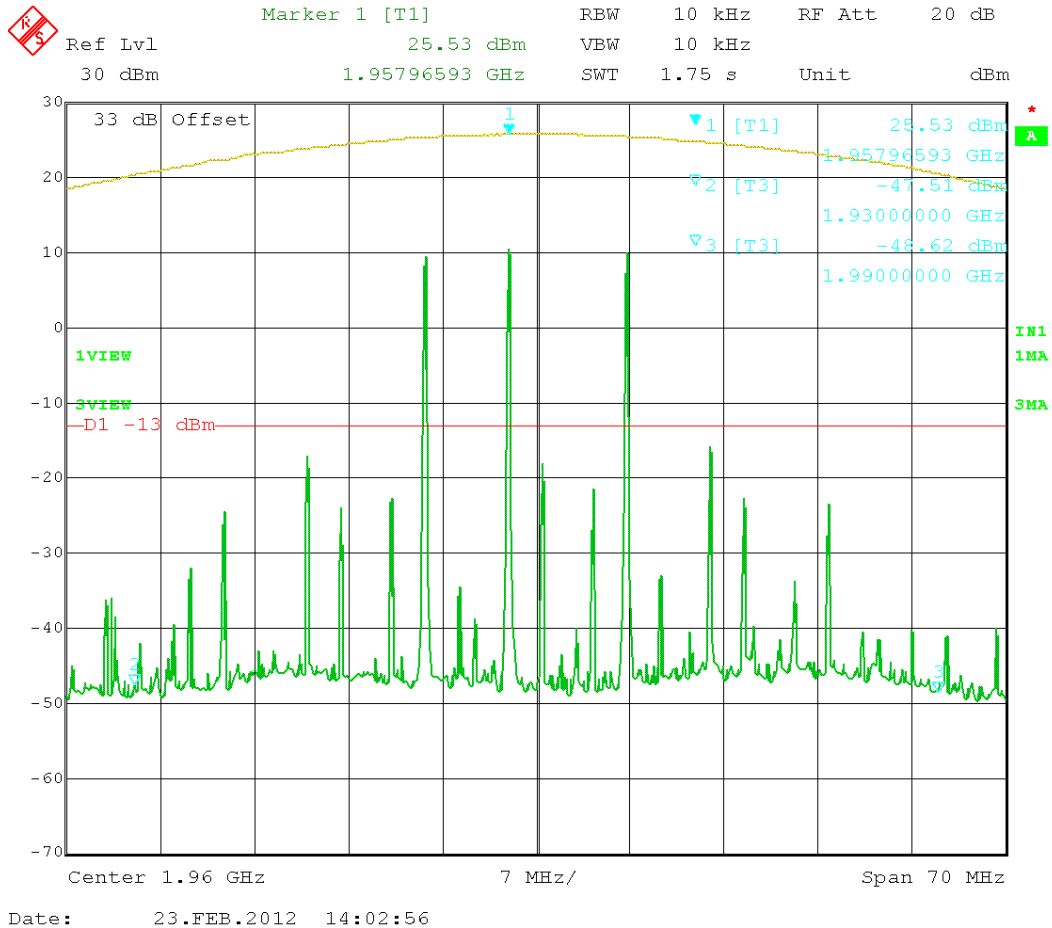

Figure 39: GSM 3 tones intermodulation - (1930 – 1990) MHz

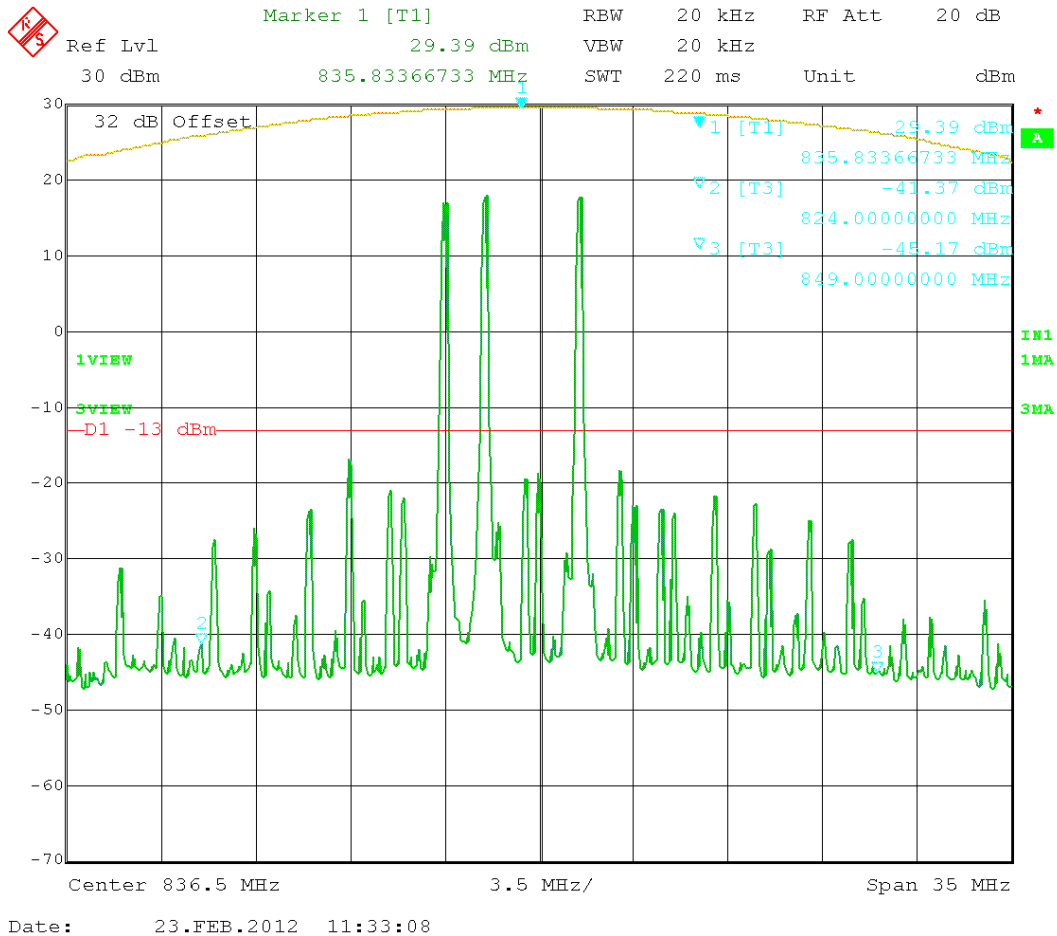

Figure 40: GSM 3 tones intermodulation - (824 – 849) MHz

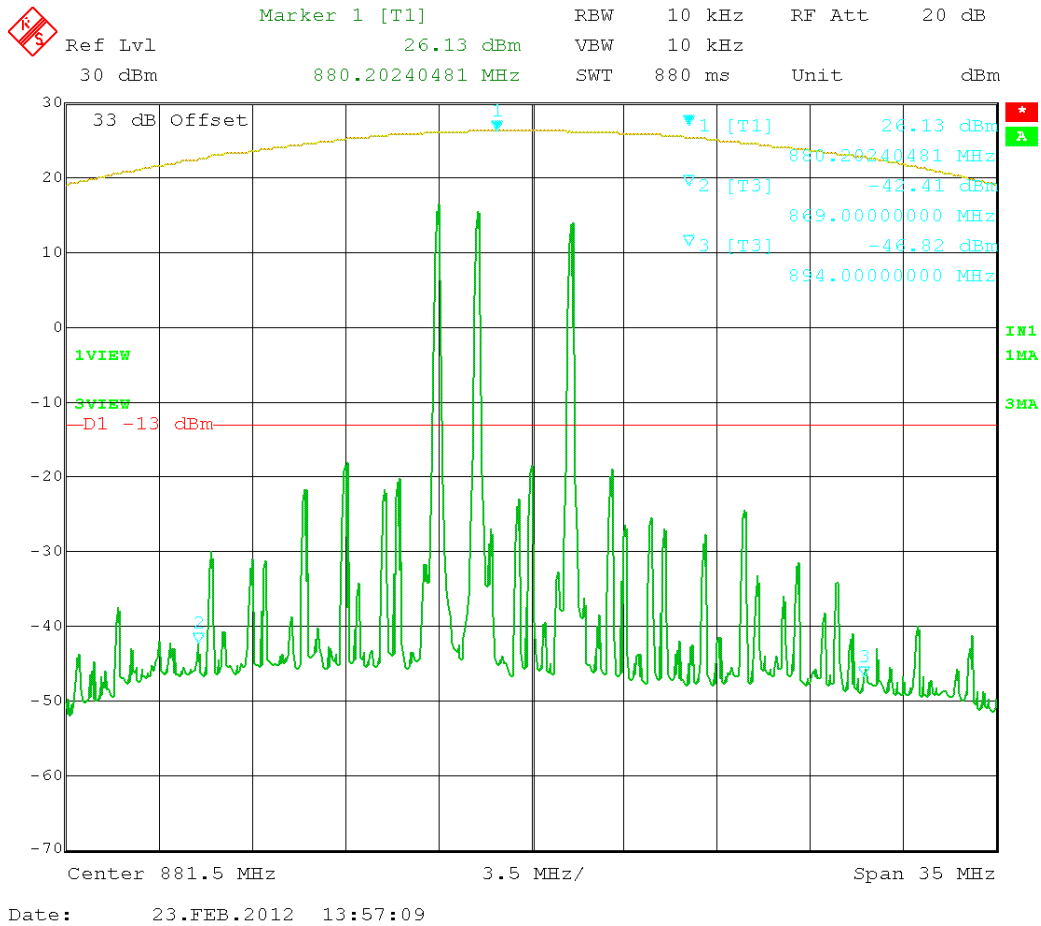

Figure 41: GSM 3 tones intermodulation - (869 – 894) MHz

SPURIOUS EMISSIONS AT ANTENNA TERMINALS

Rule Parts No.: Pt 2.1051

Requirements: Emissions must be $43 + 10\log(P_o)$ dB below the mean power output of the transmitter:

$$1850 - 1910 \text{ MHz: } 43 + 10\log(1.0) = 43 \text{ dBc}$$

$$1930 - 1990 \text{ MHz: } 43 + 10\log(1.0) = 43 \text{ dBc}$$

Test Result: The DUT meets the requirements.

Test Data Table 23 – Conducted Emissions – CDMA 1900 – Uplink

Emission Frequency MHz	dB Below Carrier (dBc)	Emission Frequency MHz	dB Below Carrier (dBc)	Emission Frequency MHz	dB Below Carrier (dBc)
1851.25		1880.00		1908.75	
3702.50	65.2	3760.00	61.4	3817.50	58.1
5553.75	64.4	5640.00	63.7	5726.25	62.8
7405.00	64.5	7520.00	65.4	7635.00	63.1
9256.25	65.2	9400.00	66.0	9543.75	63.4
11107.50	NF	11280.00	NF	11452.50	NF
12958.75	NF	13160.00	NF	13361.25	NF
14810.00	NF	15040.00	NF	15270.00	NF
16661.25	NF	16920.00	NF	17178.75	NF
18512.50	NF	18800.00	NF	19087.50	NF

Test Data Table 24 – Conducted Emissions – CDMA 1900 – Downlink

Emission Frequency MHz	dB Below Carrier (dBc)	Emission Frequency MHz	dB Below Carrier (dBc)	Emission Frequency MHz	DB Below Carrier (dBc)
1931.25		1960.00		1988.75	
3862.50	59.2	3920.00	60.7	3977.50	58.4
5793.75	59.1	5880.00	61.3	5966.25	60.5
7725.00	59.4	7840.00	60.7	7955.00	61.2
9656.25	59.7	9800.00	61.9	9943.75	61.0
11587.50	NF	11760.00	NF	11932.50	NF
13518.75	NF	13720.00	NF	13921.25	NF
15450.00	NF	15680.00	NF	15910.00	NF
17381.25	NF	17640.00	NF	17898.75	NF
19312.50	NF	19600.00	NF	19887.50	NF



Test Data Table 25 – Conducted Emissions – GSM 1900 - Uplink

Emission Frequency MHz	dB Below Carrier (dBc)	Emission Frequency MHz	dB Below Carrier (dBc)	Emission Frequency MHz	dB Below Carrier (dBc)
1850.20		1880.00		1909.80	
3700.40	63.5	3760.00	60.1	3819.60	57.8
5550.60	61.3	5640.00	62.6	5729.40	59.4
7400.80	62.2	7520.00	62.9	7639.20	59.6
9251.00	63.4	9400.00	64.2	9549.00	60.0
11101.20	NF	11280.00	NF	11458.80	NF
12951.40	NF	13160.00	NF	13368.60	NF
14801.60	NF	15040.00	NF	15278.40	NF
16651.80	NF	16920.00	NF	17188.20	NF
18502.00	NF	18800.00	NF	19098.00	NF

Test Data Table 26 – Conducted Emissions – GSM 1900 - Downlink

Emission Frequency MHz	dB Below Carrier (dBc)	Emission Frequency MHz	dB Below Carrier (dBc)	Emission Frequency MHz	dB Below Carrier (dBc)
1930.20		1960.00		1989.80	
3860.40	56.5	3920.00	57.2	3979.60	55.1
5790.60	56.0	5880.00	58.6	5969.40	57.8
7720.80	56.8	7840.00	58.4	7959.20	58.7
9651.00	55.7	9800.00	60.0	9949.00	59.1
11581.20	NF	11760.00	NF	11938.80	NF
13511.40	NF	13720.00	NF	13928.60	NF
15441.60	NF	15680.00	NF	15918.40	NF
17371.80	NF	17640.00	NF	17908.20	NF
19302.00	NF	19600.00	NF	19898.00	NF

Test Data Table 27 – Conducted Emissions – CDMA 800 - Uplink

Emission Frequency MHz	dB Below Carrier (dBc)	Emission Frequency MHz	dB Below Carrier (dBc)	Emission Frequency MHz	dB Below Carrier (dBc)
825.25		836.50		847.75	
1650.50	62.1	1673.00	62.9	1695.50	62.0
2475.75	59.3	2509.50	62.4	2543.25	59.9
3301.00	60.9	3346.00	63.4	3391.00	63.7
4126.25	61.2	4182.50	63.1	4238.75	63.0
4951.50	NF	5019.00	NF	5086.50	NF
5776.75	NF	5855.50	NF	5934.25	NF
6602.00	NF	6692.00	NF	6782.00	NF
7427.25	NF	7528.50	NF	7629.75	NF
8252.50	NF	8365.00	NF	8477.50	NF

APPLICANT: WILSON ELECTRONICS, INC.

FCC ID: PWO275165

Report #: W\WILSON_PWO\3089AUT11\3089AUT11TestReport.doc Page 69 of 76



Test Data Table 28 – Conducted Emissions – CDMA 800 - Downlink

Emission Frequency MHz	dB Below Carrier (dBc)	Emission Frequency MHz	dB Below Carrier (dBc)	Emission Frequency MHz	dB Below Carrier (dBc)
870.25		881.50		892.75	
1740.50	57.2	1763.00	57.5	1785.50	54.6
2610.75	57.4	2644.50	57.3	2678.25	54.8
3481.00	55.7	3526.00	56.7	3571.00	55.4
4351.25	57.2	4407.50	57.8	4463.75	55.3
5221.50	56.7	5289.00	56.5	5356.50	53.6
6091.75	NF	6170.50	NF	6249.25	NF
6962.00	NF	7052.00	NF	7142.00	NF
7832.25	NF	7933.50	NF	8034.75	NF
8702.50	NF	8815.00	NF	8927.50	NF

Test Data Table 29 – Conducted Emissions – GSM 800 – Uplink

Emission Frequency MHz	dB Below Carrier (dBc)	Emission Frequency MHz	dB Below Carrier (dBc)	Emission Frequency MHz	dB Below Carrier (dBc)
824.20		836.50		848.80	
1648.40	64.6	1673.00	66.4	1697.60	63.1
2472.60	60.7	2509.50	63.9	2546.40	61.6
3296.80	62.9	3346.00	64.8	3395.20	64.7
4121.00	63.4	4182.50	66.2	4244.00	64.1
4945.20	NF	5019.00	NF	5092.80	NF
5769.40	NF	5855.50	NF	5941.60	NF
6593.60	NF	6692.00	NF	6790.40	NF
7417.80	NF	7528.50	NF	7639.20	NF
8242.00	NF	8365.00	NF	8488.00	NF

Test Data Table 30 – Conducted Emissions – GSM 800 - Downlink

Emission Frequency MHz	dB Below Carrier (dBc)	Emission Frequency MHz	dB Below Carrier (dBc)	Emission Frequency MHz	dB Below Carrier (dBc)
869.20		881.50		893.80	
1738.40	62.2	1763.00	62.8	1787.60	59.9
2607.60	61.3	2644.50	63.7	2681.40	59.4
3476.80	59.0	3526.00	60.0	3575.20	58.6
4346.00	61.0	4407.50	61.7	4469.00	59.7
5215.20	61.1	5289.00	61.0	5362.80	58.2
6084.40	NF	6170.50	NF	6256.60	NF
6953.60	NF	7052.00	NF	7150.40	NF
7822.80	NF	7933.50	NF	8044.20	NF
8692.00	NF	8815.00	NF	8938.00	NF

APPLICANT: WILSON ELECTRONICS, INC.

FCC ID: PWO275165

Report #: W\WILSON_PWO\3089AUT11\3089AUT11TestReport.doc Page 70 of 76

OUT OF BAND REJECTION: FREQUENCY RESPONSE

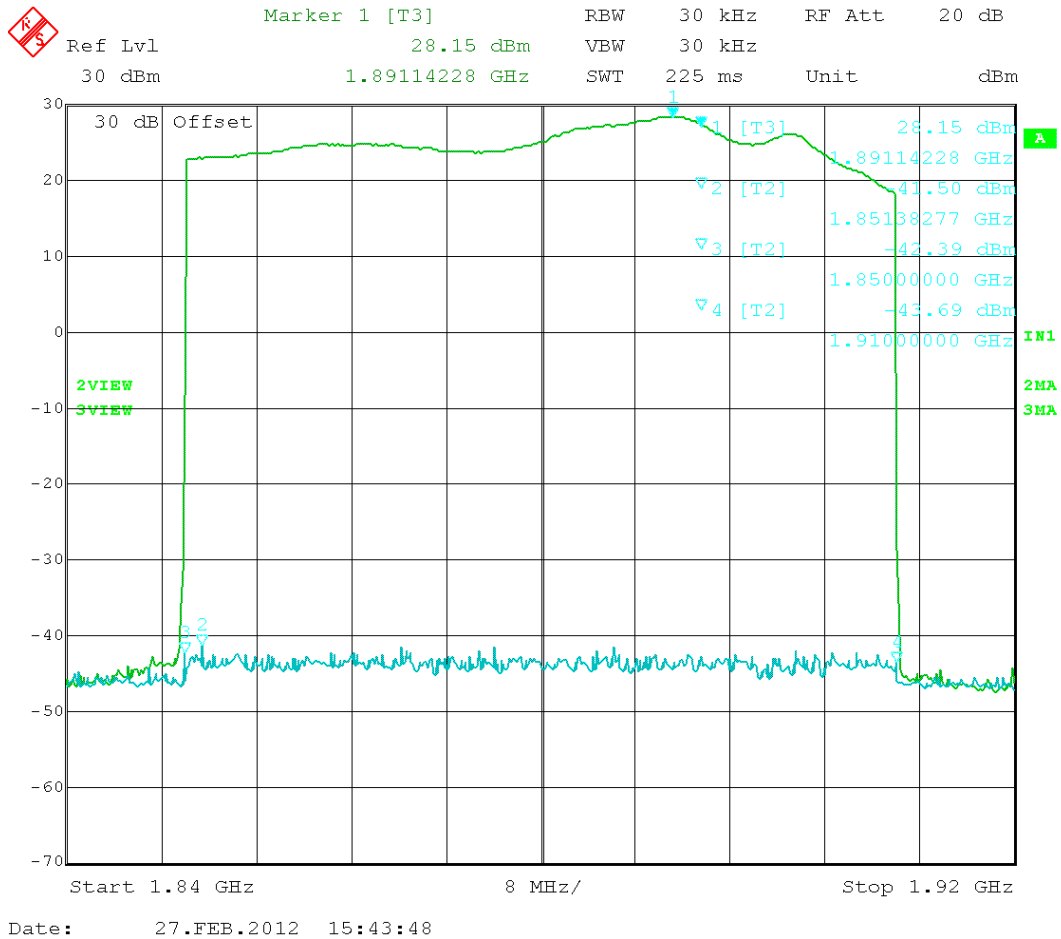

Figure 42. Frequency response (1850 – 1910) MHz band

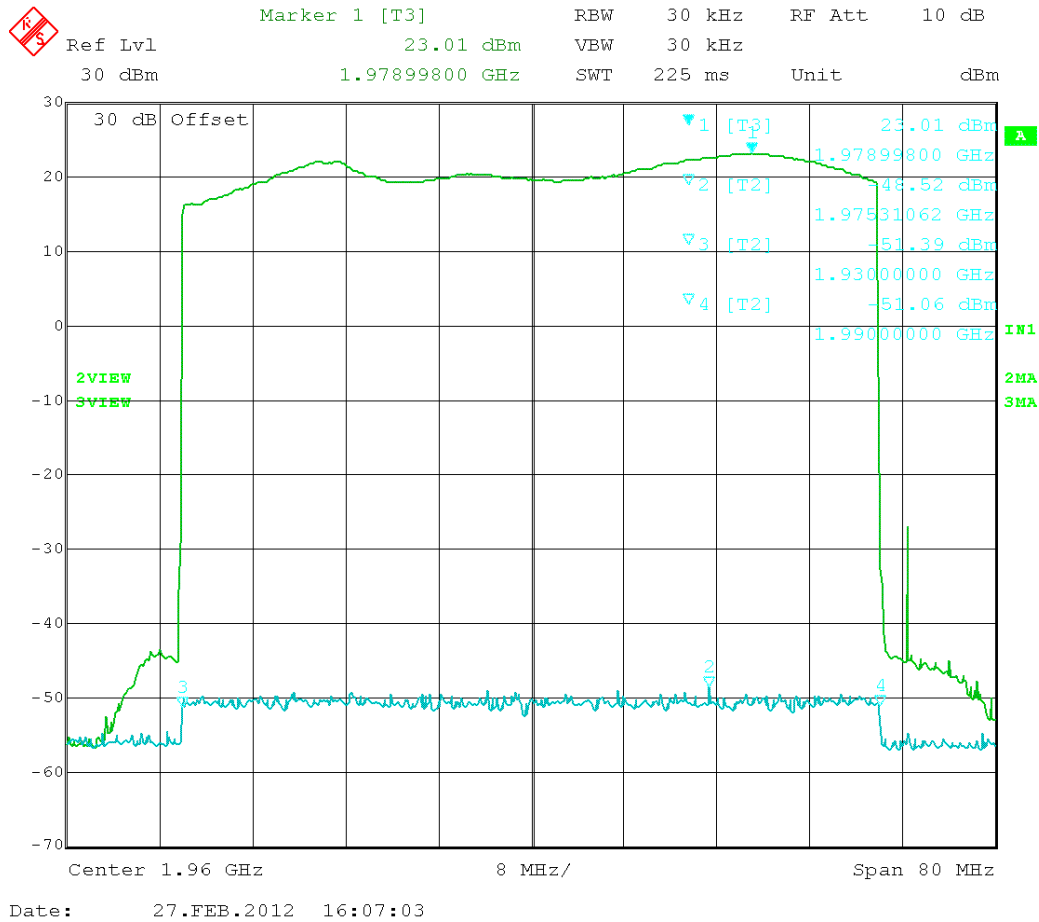

Figure 43. Frequency response (1930 – 1990) MHz band

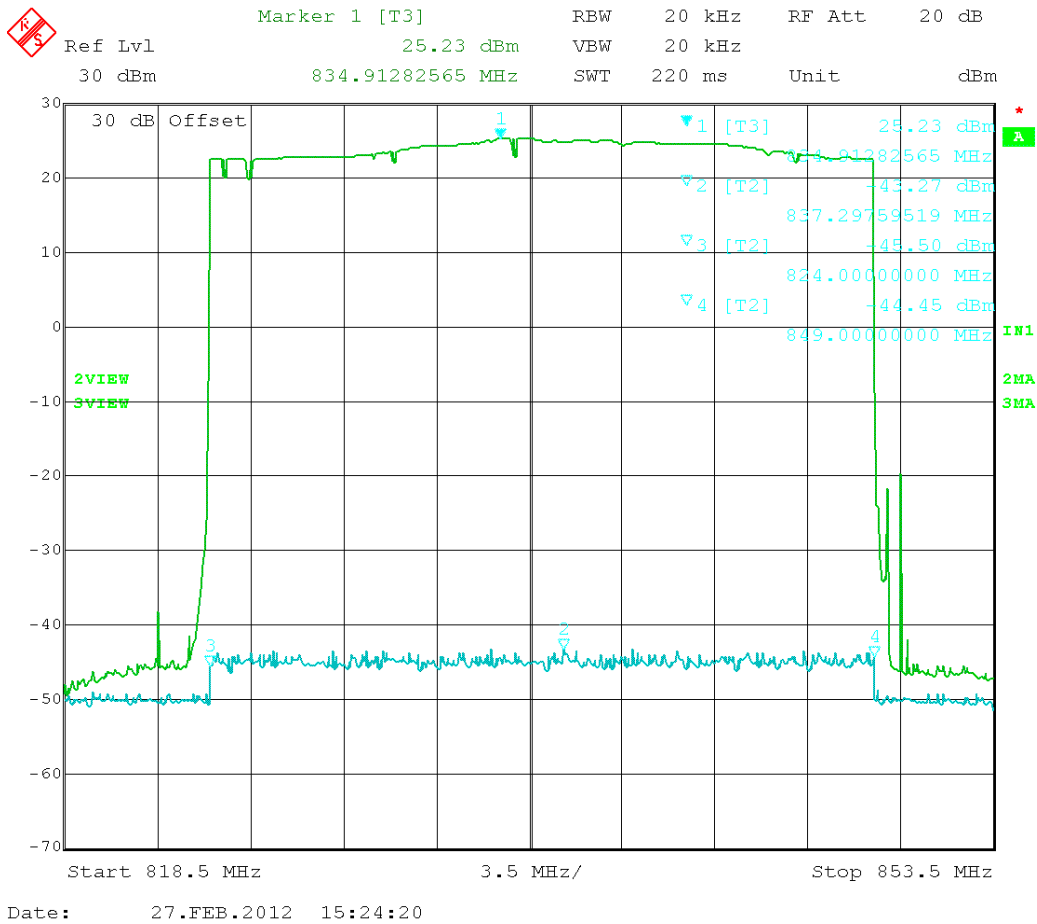

Figure 44. Frequency response (824 – 849) MHz band

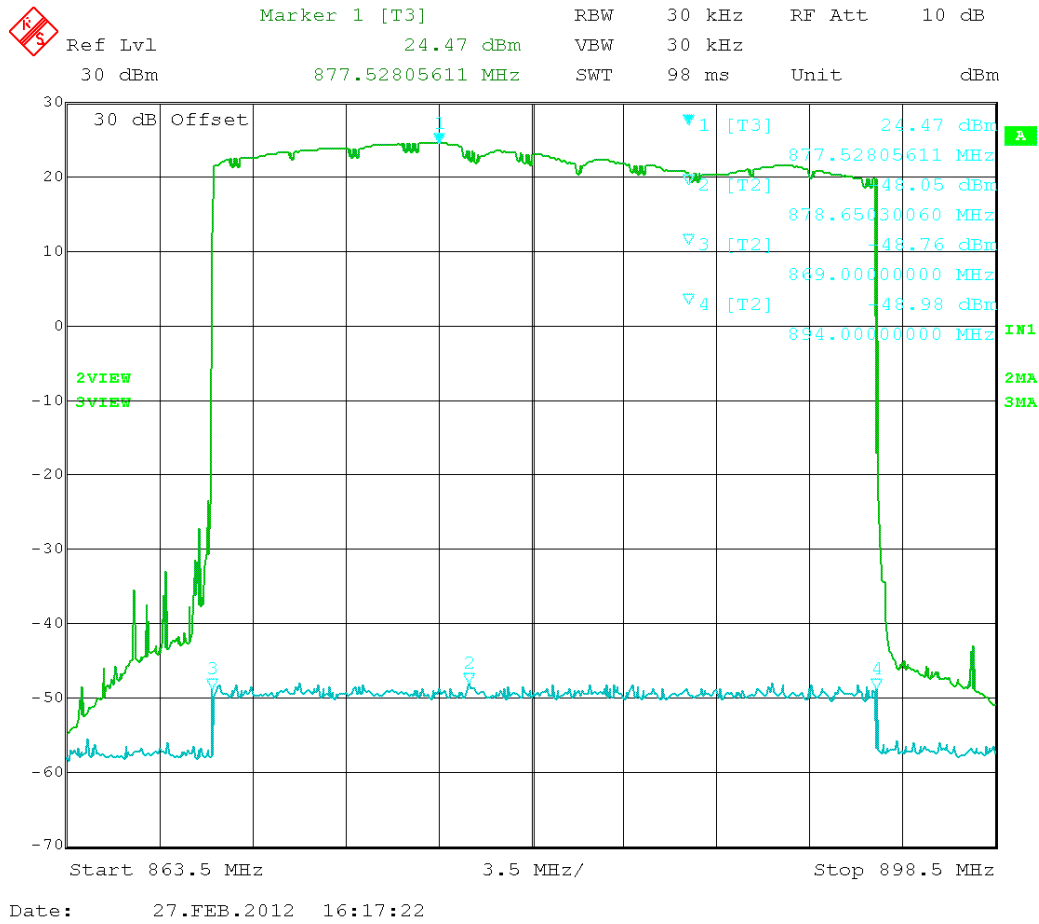

Figure 45. Frequency response (869 – 894) MHz band

FIELD STRENGTH OF SPURIOUS EMISSIONS

Rule Parts No.: Pt 2.1053

Requirements: Emissions must be $43 + 10\log(P_o)$ dB below the mean power output of the amplifier:

$$43 + 10\log(1.39) = 44 \text{ dB}$$

$$43 + 10\log(0.032) = 28 \text{ dB}$$

Test Result: The test data indicates the DUT meets the requirements

Test Data Table 31 – Radiated Emissions – CW (1900 MHz) – Uplink /Downlink

Emission Frequency MHz	Ant. Polarity	dB Below Carrier (dBc)	Emission Frequency MHz	Ant. Polarity	dB Below Carrier (dBc)
1880.00	0	0	1960.00	0	0
3760.00	H	76.6	3920.00	H	72.6
5640.00	H	79.0	5880.00	H	78.5
7520.00	H	79.8	7840.00	H	76.9
9400.00	H	76.8	9800.00	H	68.9
11280.00	H	74.1	11760.00	H	69.3
13160.00	H	62.6	13720.00	H/V	NF
15040.00	H/V	NF	15680.00	H/V	NF
16920.00	H/V	NF	17640.00	H/V	NF
18800.00	H/V	NF	19600.00	H/V	NF

Notes: *No other emissions were found up to the 10th harmonics - NOISE FLOOR

[Continued]

Test Data Table 32 – Radiated Emissions – CW (800 MHz) – Uplink /Downlink

Emission Frequency MHz	Ant. Polarity	dB Below Carrier (dBc)	Emission Frequency MHz	Ant. Polarity	dB Below Carrier (dBc)
836.50	0	0	881.50	0	0
1673.00	H	87.0	1763.00	H	82.0
2509.50	V	68.3	2644.50	V	67.1
3346.00	H	69.9	3526.00	H	75.4
4182.50	H	76.6	4407.50	H	76.9
5019.00	V	74.0	5289.00	H	77.5
5855.50	H	78.0	6170.50	H	71.3
6692.00	H/V	NF	7052.00	H/V	NF
7528.50	H/V	NF	7933.50	H/V	NF
8365.00	H/V	NF	8815.00	H/V	NF

Notes: *No other emissions were found up to the 10th harmonics - NOISE FLOOR