

FCC PART 15 SUBPART C
EMI MEASUREMENT AND TEST REPORT

For
smartBridges Pte Ltd

10 Anson Road #22-14
International Plaza
Singapore 079903

FCC ID: PWGAIRPOINTPRO

April 17, 2002

This Report Concerns: <input checked="" type="checkbox"/> Original Report	Equipment Type: Wireless AirPointPRO
Test Engineer: Jeff Lee	
Report No.: R0203252	
Test Date: April 15 2002	
Reviewed By: 	
	John Y. Chan – Engineering Manager
Prepared By: Bay Area Compliance Laboratory Corporation 230 Commercial Street Sunnyvale, CA 94085 Tel: (408) 732-9162 Fax: (408) 732 9164	

Note: This test report is specially limited to the above client company and the product sample only. It may not be duplicated without prior written consent of Bay Area Compliance Laboratory Corporation. This report **must not** be used by the client to claim product endorsement by NVLAP or any agency of the U.S. Government.

TABLE OF CONTENTS

1 - GENERAL INFORMATION4

1.1 PRODUCT DESCRIPTION FOR EQUIPMENT UNDER TEST (EUT)4

1.2 OBJECTIVE4

1.3 RELATED SUBMITTAL(S)/GRANT(S).....4

1.4 TEST METHODOLOGY4

1.5 TEST FACILITY5

1.6 TEST EQUIPMENT LIST AND DETAILS.....5

1.7 LOCAL SUPPORT EQUIPMENT LIST AND DETAILS6

1.8 HOST SYSTEM CONFIGURATION LIST AND DETAILS6

1.9 EXTERNAL I/O CABLING LIST AND DETAILS6

2 - SYSTEM TEST CONFIGURATION7

2.1 JUSTIFICATION7

2.2 EUT EXERCISE SOFTWARE7

2.3 SPECIAL ACCESSORIES7

2.4 SCHEMATICS / BLOCK DIAGRAM7

2.5 EQUIPMENT MODIFICATIONS7

2.6 CONFIGURATION OF TEST SYSTEM8

2.7 TEST SETUP BLOCK DIAGRAM8

3 - SUMMARY OF TEST RESULTS.....9

4 - CONDUCTED OUTPUT POWER MEASUREMENT.....10

4.1 STANDARD APPLICABLE10

4.2 MEASUREMENT PROCEDURE10

4.4 TEST RESULT10

5 - SPURIOUS EMISSION.....13

5.1 STANDARD APPLICABLE13

5.2 MEASUREMENT PROCEDURE13

5.3 MEASUREMENT DATA13

6 - POWER DENSITY20

6.1 STANDARD APPLICABLE20

6.2 MEASUREMENT PROCEDURE20

6.3 TEST RESULTS20

7 - 6DB BANDWIDTH.....23

7.1 STANDARD APPLICABLE23

7.2 MEASUREMENT PROCEDURE23

7.3 TEST RESULT23

8 - 100 KHZ BANDWIDTH OF BAND EDGES MEASUREMENT26

8.1 STANDARD APPLICABLE26

8.2 MEASUREMENT PROCEDURE26

8.3 TEST RESULTS26

9 - ANTENNA REQUIREMENT29

9.1 STANDARD APPLICABLE29

9.2 ANTENNA CONNECTED CONSTRUCTION29

10 - RF EXPOSURE.....29

11 - SPURIOUS RADIATED EMISSION DATA30

11.1 MEASUREMENT UNCERTAINTY31

11.2 EUT SETUP31

11.3 SPECTRUM ANALYZER SETUP31

11.4 TEST PROCEDURE32

11.5 CORRECTED AMPLITUDE & MARGIN CALCULATION32

11.6 SUMMARY OF TEST RESULTS	32
11.7 FINAL TEST RESULT	33
12 - CONDUCTED EMISSIONS TEST DATA.....	35
12.1 MEASUREMENT UNCERTAINTY	35
12.2 EUT SETUP	35
12.3 SPECTRUM ANALYZER SETUP	35
12.4 TEST PROCEDURE	36
12.5 SUMMARY OF TEST RESULTS	36
12.6 CONDUCTED EMISSIONS TEST DATA	36
12.7 PLOT OF CONDUCTED EMISSIONS TEST DATA	37
13 - PROCESSING GAIN	38
13.1 BRIEF EXPLANATIONS ON PROCESSING GAIN DATA	38
13.2 TEST DATA FOR PROCESSING GAIN	38
13.3 TEST SETUP - PROCESSING GAIN	38

1 - GENERAL INFORMATION

1.1 Product Description for Equipment Under Test (EUT)

The *smartBridges Pte Ltd*'s product, FCC ID: PWGAIRPOINTPRO or the "EUT" as referred to in this report is a Wireless airPointPRO that conforms to the IEEE standard 802.11b and operates in the 2.4GHz ISM band. It has data rate of up to 11Mbps, which makes it one of the fastest Wireless Access Point in the market today. AirPointPRO operate in infrastructure mode providing the wireless network connection to any Wi-Fi compliant Wireless Client Adapter.

The EUT measures approximately 5.9”L x 4.5”W x 4.0”H.

The EUT provides the following feature(s):

- One (1) Ethernet port
- Two (2) external Antennas
- Three (3) LED indicators

The EUT utilized SmartBridges's power adapter, M/N: SMA210-2112C, S/N: 00000148.

1.2 Objective

This type approval report is prepared on behalf of *smartBridges Pte Ltd* in accordance with Part 2, Subpart J, Part 15, Subparts A, B and C of the Federal Communication Commissions rules.

The objective of the manufacturer is to demonstrate compliance with FCC rules for Output Power, Antenna Requirements, 6 dB Bandwidth, power density, 100 kHz Bandwidth of Band Edges Measurement, Conducted and Spurious Radiated Emission, and processing gain.

1.3 Related Submittal(s)/Grant(s)

No Related Submittal(s).

1.4 Test Methodology

All measurements contained in this report were conducted with ANSI C63.4 –1992, American National Standard for Methods of Measurement of Radio-Noise Emissions from Low-Voltage Electrical and Electronic Equipment in the range of 9 kHz to 40 GHz. All radiated and conducted emissions measurement was performed at Bay Area Compliance Laboratory Corporation. The radiated testing was performed at an antenna-to-EUT distance of 3 Meters.

1.5 Test Facility

The Open Area Test site used by Bay Area Compliance Laboratory Corporation to collect radiated and conducted emission measurement data is located in the back parking lot of the building at 230 Commercial Street, Sunnyvale, California, USA.

Test site at Bay Area Compliance Laboratory Corporation has been fully described in reports submitted to the Federal Communication Commission (FCC) and Voluntary Control Council for Interference (VCCI).

The details of these reports has been found to be in compliance with the requirements of Section 2.948 of the FCC Rules on February 11 and December 10, 1997 and Article 8 of the VCCI regulations on December 25, 1997. The facility also complies with the radiated and AC line conducted test site criteria set forth in ANSI C63.4-1992.

The Federal Communications Commission and Voluntary Control Council for Interference has the reports on file and is listed under FCC file 31040/SIT 1300F2 and VCCI Registration No.: C-1298 and R-1234. The test site has been approved by the FCC and VCCI for public use and is listed in the FCC Public Access Link (PAL) database.

Additionally, Bay Area Compliance Laboratory Corporation is a National Institute of Standards and Technology (NIST) accredited laboratory, under the National Voluntary Laboratory Accredited Program (NVLAP). The scope of the accreditation covers the FCC Method - 47 CFR Part 15 - Digital Devices, IEC/CISPR 22: 1998, and AS/NZS 3548: Electromagnetic Interference - Limits and Methods of Measurement of Information Technology Equipment test methods under NVLAP Lab Code 200167-0.

1.6 Test Equipment List and Details

Manufacturer	Description	Model	Serial Number	Cal. Due Date
HP	Spectrum Analyzer	8568B	2610A02165	12/6/02
HP	Spectrum Analyzer	8593B	2919A00242	12/20/02
HP	Amplifier	8349B	2644A02662	12/20/02
HP	Quasi-Peak Adapter	85650A	917059	12/6/02
HP	Amplifier	8447E	1937A01046	12/6/02
A.H. System	Horn Antenna	SAS0200/571	261	12/27/02
Com-Power	Log Periodic Antenna	AL-100	16005	11/2/02
Com-Power	Biconical Antenna	AB-100	14012	11/2/02
Solar Electronics	LISN	8012-50-R-24-BNC	968447	12/28/02
Com-Power	LISN	LI-200	12208	12/20/02
Com-Power	LISN	LI-200	12005	12/20/02
BACL	Data Entry Software	DES1	0001	12/20/02

* Statement of Traceability: Bay Area Compliance Laboratory Corp. certifies that all calibration has been performed using suitable standards traceable to national institute of standard and technology (NIST).

1.7 Local Support Equipment List and Details

Manufacturer	Description	Model	Serial Number	FCC ID
Premio	PC System	Minos MT Series	None	DOC
KDS	Monitor	EVOKD-1731	0891265478	DOC
Microsoft	KB	PCVA-KB1P/UA	0000348	DOC
Microsoft	Mouse	MUS3P	None	JKGMUS3P01
EVEREX	Modem	EV-945	None	E3E5UVEV-945
HP	Printer	2225C	2821S14783	DOC

1.8 Host System Configuration List and Details

Manufacturer	Description	Model	Serial Number	FCC ID
Intel	MB	None	KB0610285	DOC
NEC	Floppy Drive	FD1231T	D9WL01MB3634	DOC
Maxtor	HD	54098U8	K806D1SC	DOC
Compaq	P/S	PS-7201-2C	00614854	DOC
Compaq	CD-ROM	CTN-485	201019006824	DOC
Premio	Chassis	MT Series	None	None

1.9 External I/O Cabling List and Details

Cable Description	Length (M)	Port/From	To
Shielded KB Cable	1.6	KB Port/Host	KB
Shielded Mouse Cable	1.5	Mouse Port/Host	Mouse
Shielded Serial Cable	1.5	Serial Port/Host	Modem
Shielded Printer Cable	2.0	Parallel Port/Host	Printer
Shielded Video Cable	1.8	VGA/Host	Monitor
Shielded RJ45 Cable	1.0	RJ45 Port/Host	RJ45 Port/EUT

2 - SYSTEM TEST CONFIGURATION

2.1 Justification

The host system was configured for testing in a typical fashion (as a normally used by a typical user).

The EUT was tested in the normal (native) operating mode to represent *worst*-case results during the final qualification test.

The power supply used in the host system is SmartBridges Power Supply, M/N: SMA10-2112C.

2.2 EUT Exercise Software

The EUT exercising program used during radiated and conducted testing was designed to exercise the various system components in a manner similar to a typical use. The test software, terminal.exe, provided by the customer, is started the Windows 98 terminal program under the Windows 98 operating system. Once loaded, the program sequentially exercises each system component.

The sequence used is as follows:

1. Lines of Hs scroll across the notebook monitor.
2. The modem(s) receives Hs.
3. The printer output Hs.

This process is continuous throughout all tests.

2.3 Special Accessories

As shown in section 2.5, all interface cables used for compliance testing are shielded as normally supplied by INMAC and their respective support equipment manufacturers. The printer, the modem and the VGA monitor featured shielded metal connectors.

2.4 Schematics / Block Diagram

Appendix A contains a copy of the EUT's schematics diagram as reference.

2.5 Equipment Modifications

No modifications were made by BACL Corporation to ensure the EUT to comply with the applicable limits and requirements.

2.6 Configuration of Test System

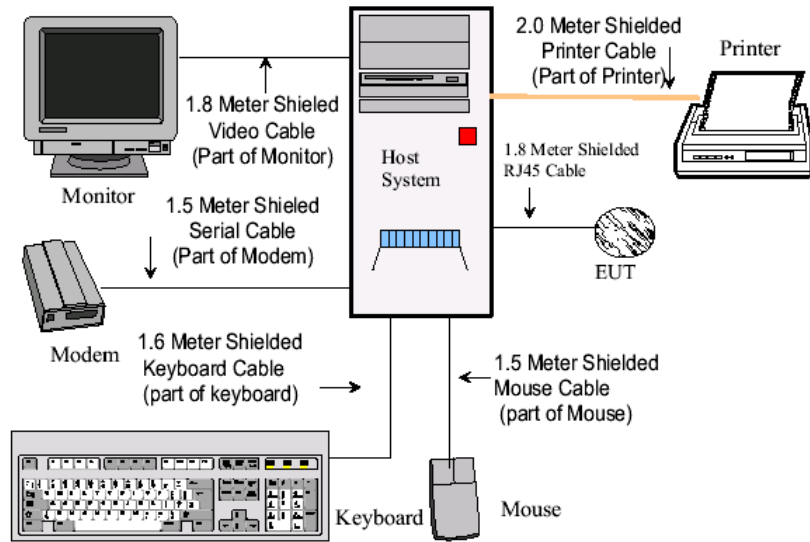

2.7 Test Setup Block Diagram

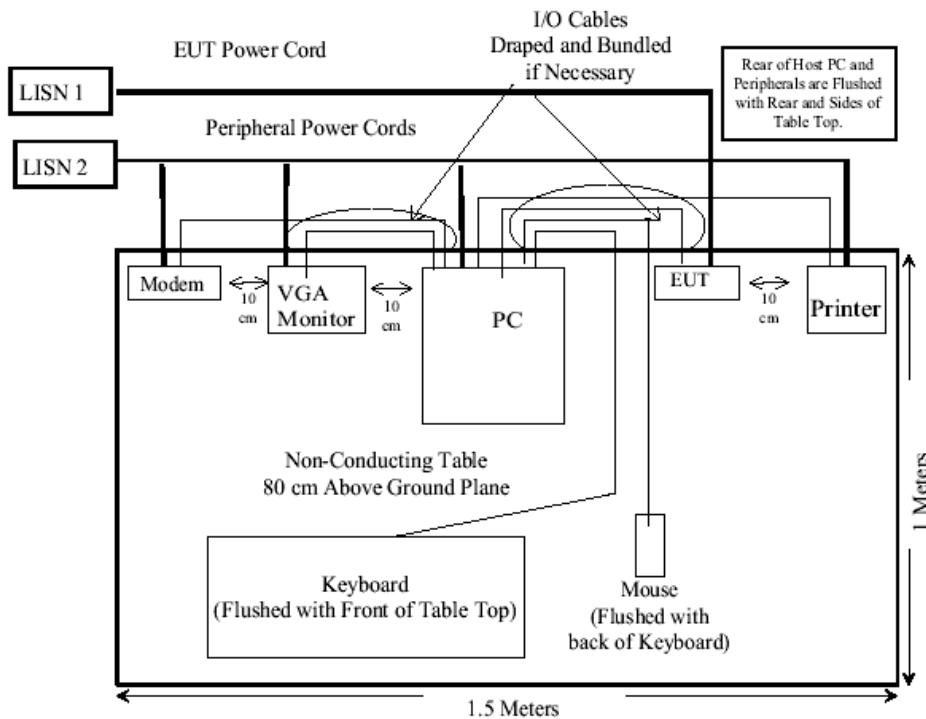

3 - SUMMARY OF TEST RESULTS

FCC Rules	Description	Result
§ 15.205	Restricted Bands	Compliant
§ 2.1091	RF Safety Requirements	Compliant
§15.203	Antenna Requirement	Compliant
§15.207 (a)	Conducted Emission	Compliant
§15.209 (a)	Radiated Emission	Compliant
§15.209 (f)	Spurious Emission	Compliant
§15.247 (a) (2)	6dB Bandwidth	Compliant
§15.247 (b) (2)	Output Power	Compliant
§ 15.247 (c)	100 kHz Bandwidth of Frequency Band Edges	Compliant
§15.247 (d)	Peak Power Spectral Density	Compliant
§15.247 (e)	Processing Gain	Compliant

Note: The test data was good for test sample only. It may have deviation for other product samples.

4 - CONDUCTED OUTPUT POWER MEASUREMENT

4.1 Standard Applicable

According to §15.247(b) (2), the maximum peak output power of the intentional radiator shall not exceed 1 Watt.

4.2 Measurement Procedure

1. Place the EUT on the turntable and set it in transmitting mode.
2. Remove the antenna from the EUT and then connect a low loss RF cable from the antenna port to the power meter.

4.3 Test Equipment

Manufacturer	Model No.	Serial No.	Calibration Due Date
Agilent	E4419b	GB40202891	4/8/02
Agilent	E4412a	US38486529	4/8/02

4.4 Test Result

Antenna	Frequency (MHz)	Output Power in dBm	Output Power in W	Standard Limit	Result	Page Reference
Left	Low	19.90	0.098	≤ 1W	Compliant	Page 11
Left	Middle	19.98	0.100	≤ 1W	Compliant	Page 11
Left	High	19.92	0.098	≤ 1W	Compliant	Page 11

Antenna	Frequency (MHz)	Output Power in dBm	Output Power in W	Standard Limit	Result	Page Reference
Right	Low	19.93	0.098	≤ 1W	Compliant	Page 12
Right	Middle	19.94	0.099	≤ 1W	Compliant	Page 12
Right	High	19.92	0.098	≤ 1W	Compliant	Page 12



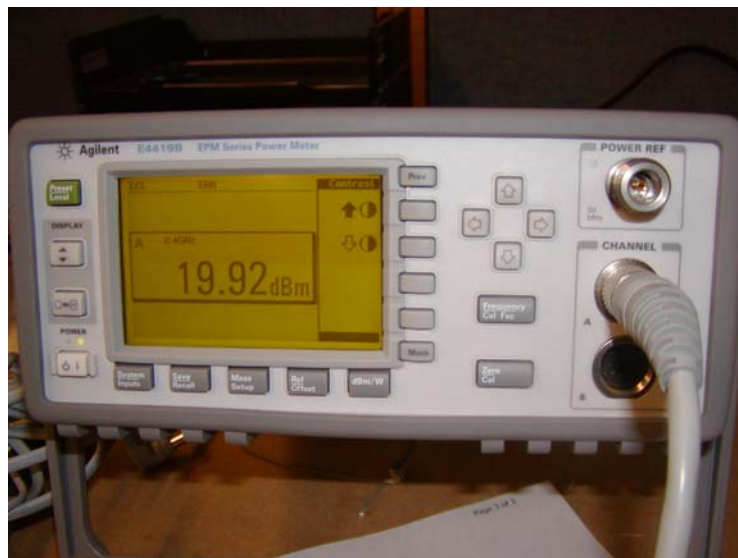

5 - SPURIOUS EMISSION

5.1 Standard Applicable

According to §15.209 (f) and §15.33(a), in some cases the emissions from an intentional radiator must be measured to beyond the tenth harmonic of the highest fundamental frequency designed to be emitted by the intentional radiator because of the incorporation of a digital device. If measurements above the tenth harmonic are so required, the radiated emissions above the tenth harmonic shall comply with the general radiated emission limits applicable to the incorporated digital device, as shown in §15.109 and as based on the frequency of the emission being measured, or, except for emissions contained in the restricted frequency bands shown in §15.205, the limit on spurious emissions specified for the intentional radiator, whichever is the higher limit.

5.2 Measurement Procedure

1. Check the calibration of the measuring instrument (SA) using either an internal calibrator or a known signal from an external generator.
2. Position the EUT as shown in figure 4 without connection to measurement instrument. Turn on the EUT and connect its antenna terminal to measurement instrument via a low loss cable. Then set it to any one measured frequency within its operating range, and make sure the instrument is operated in its linear range.
3. Set the SA on Max-Hold Mode, and then keep the EUT in transmitting mode. Record all the signals from each channel until each one has been recorded.
4. Set the SA on View mode and then plot the result on SA screen.
5. Repeat above procedures until all frequencies measured were complete.

5.3 Measurement Data

Plot(s) of Spurious Emission was presented hereinafter as reference.

Left Antenna: Page 14 - 16

Right Antenna: Page 17 - 19

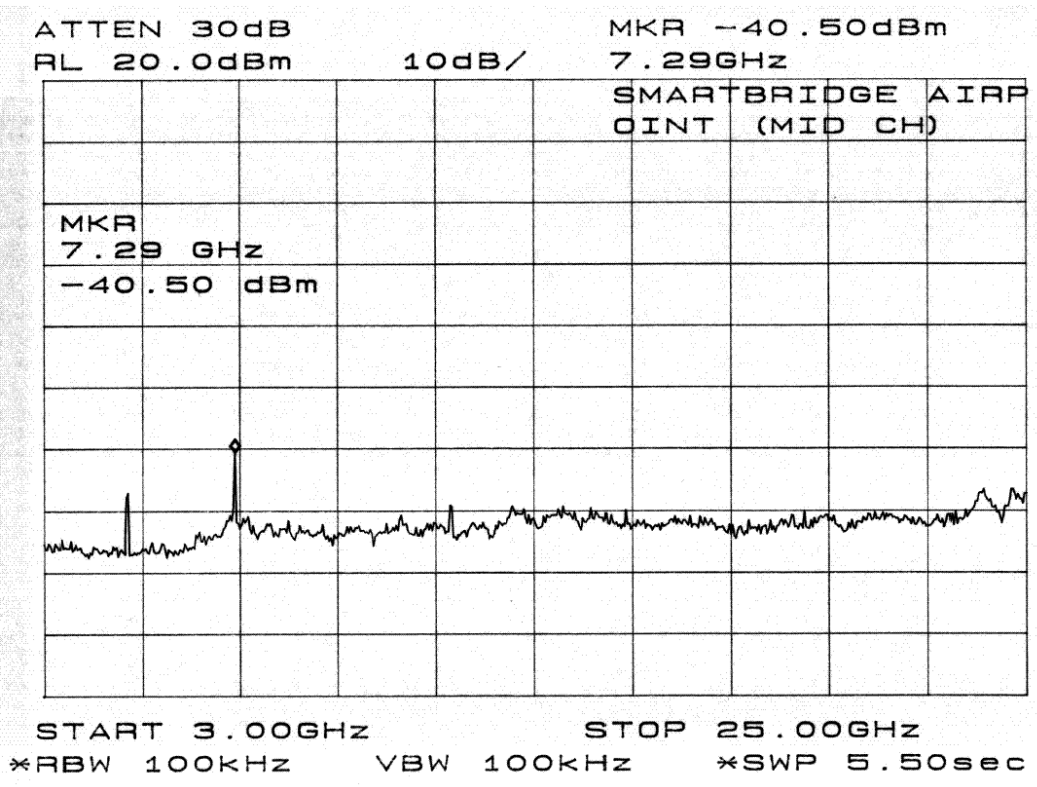
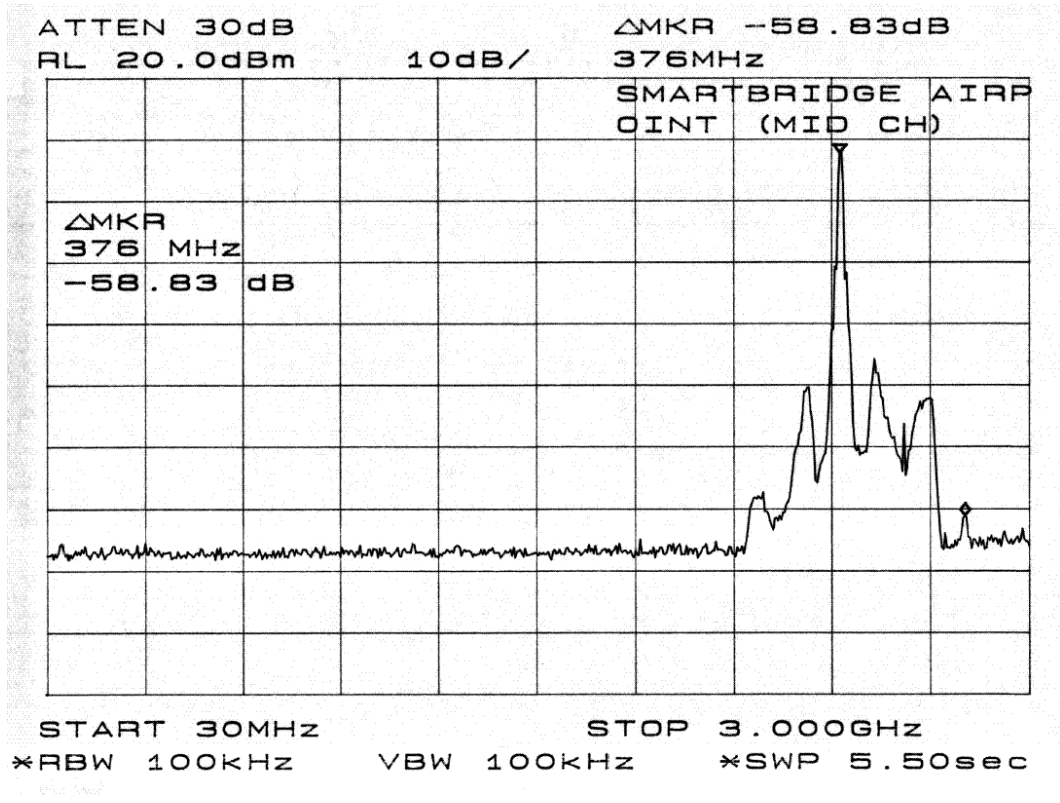

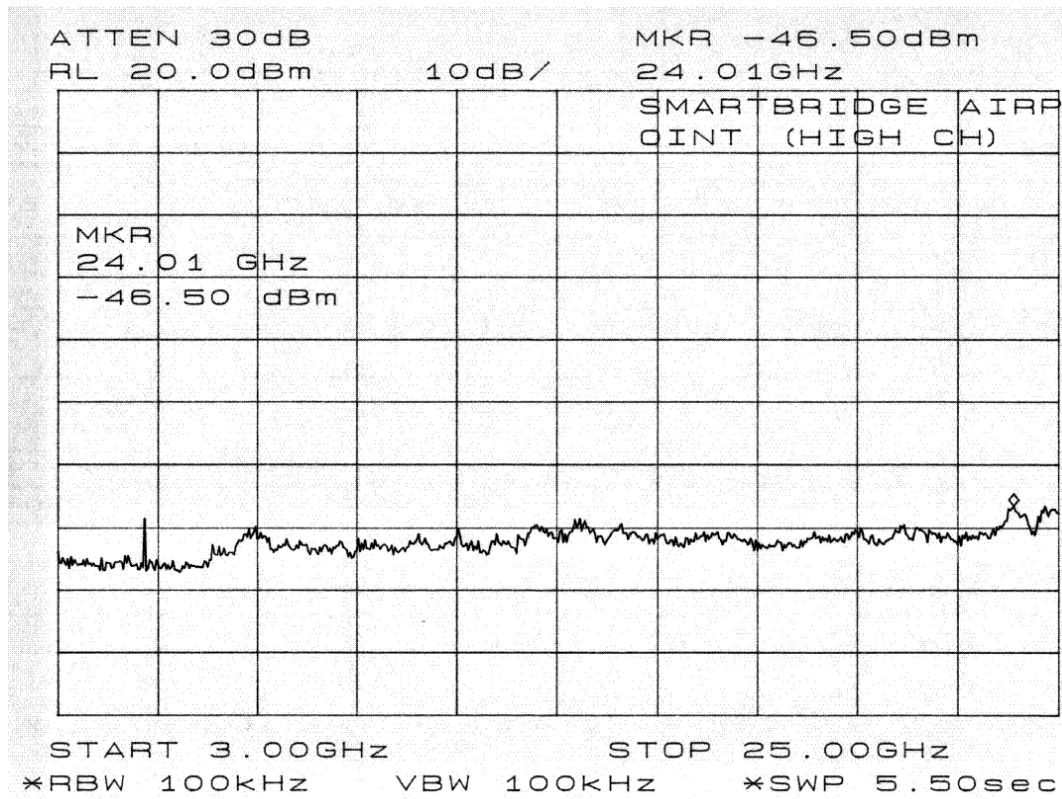
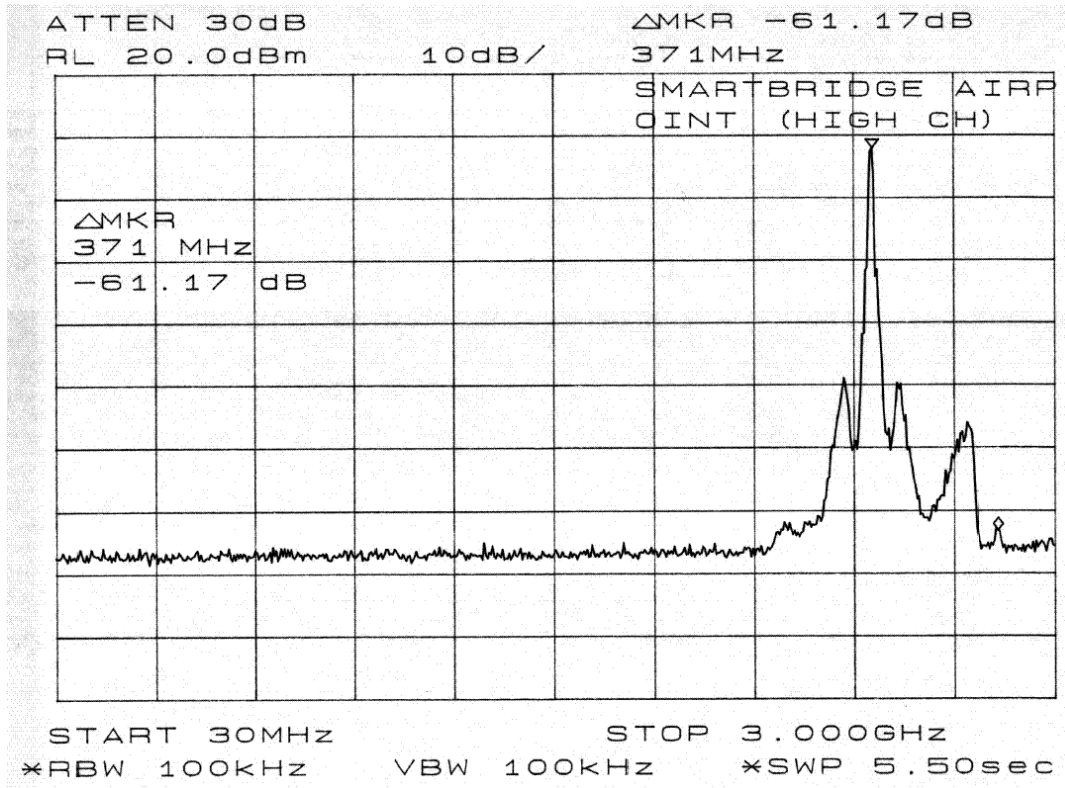

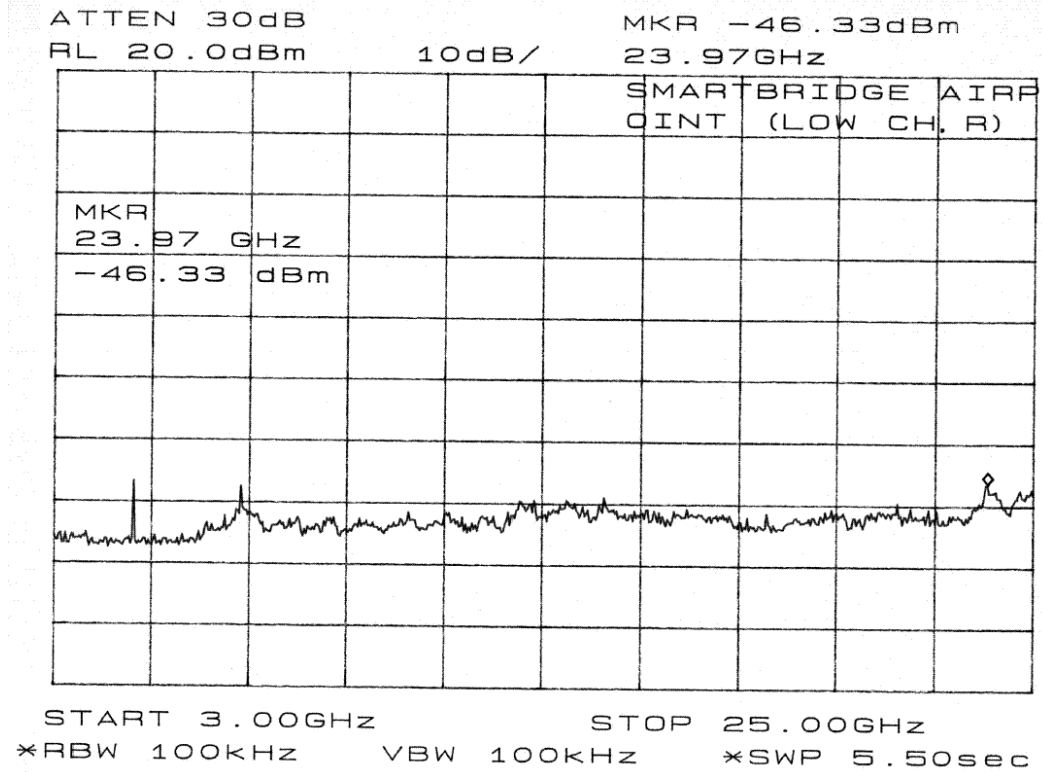
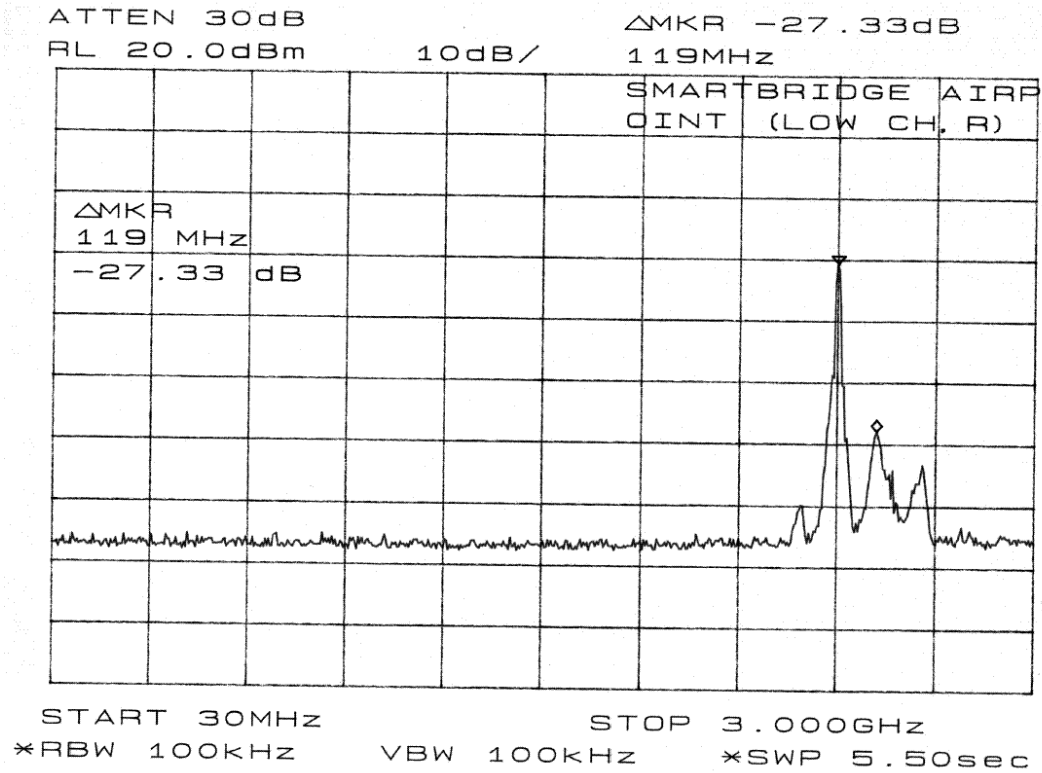

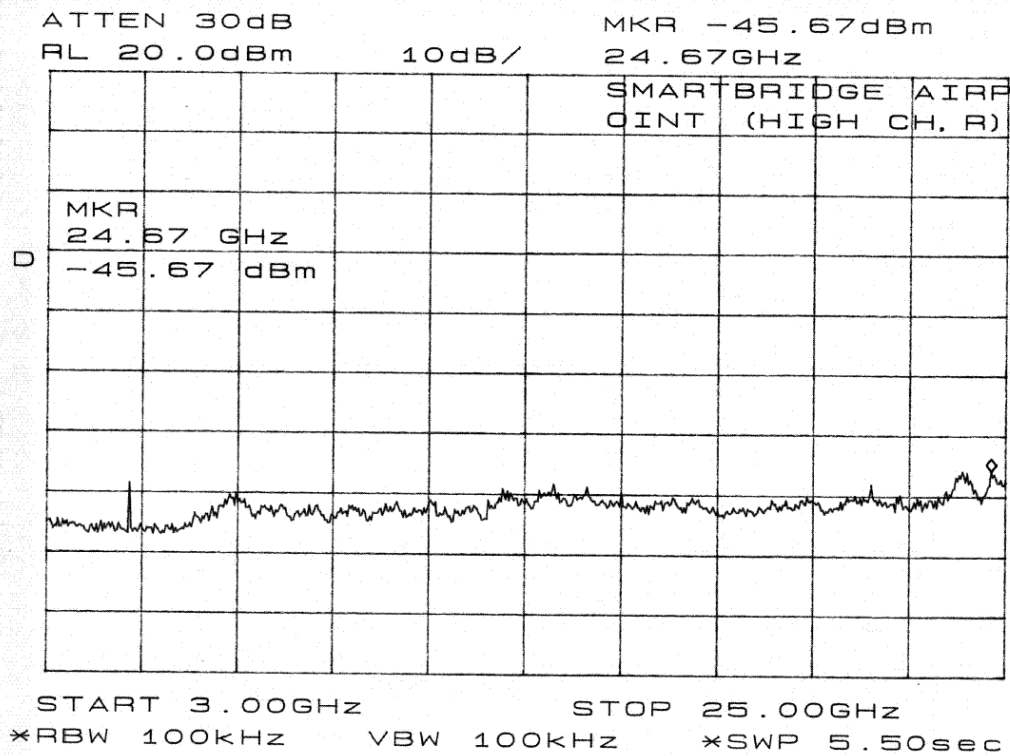
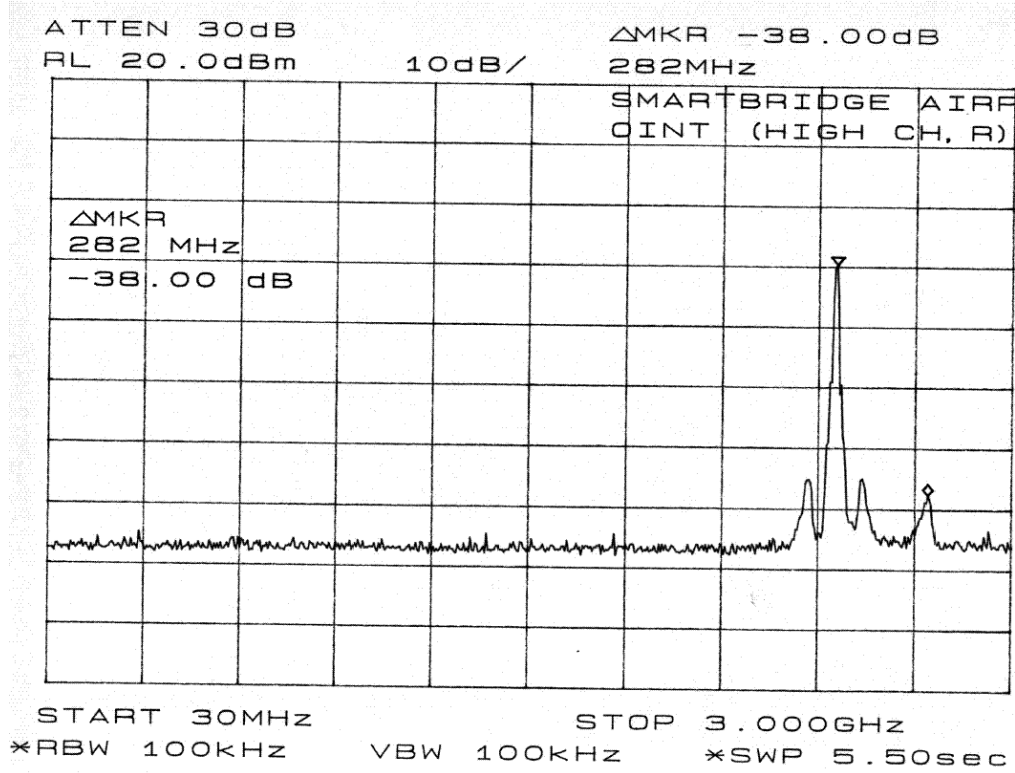

6 - POWER DENSITY

6.1 Standard Applicable

According to §15.247 (d), for direct sequence systems, the peak power spectral density conducted from the intentional radiator to the antenna shall not be greater than 8 dBm in any 3 kHz band during any time interval of continuous transmission.

6.2 Measurement Procedure

1. Check the calibration of the measuring instrument using either an internal calibrator or a known signal from an external generator.
2. Position the EUT was set without connection to measurement instrument. Turn on the EUT and connect its antenna terminal to measurement instrument via a low loss cable. Then set it to any one measured frequency within its operating range, and make sure the instrument is operated in its linear range.
3. Adjust the center frequency of SA on any frequency be measured and set SA to zero span mode. And then, set RBW and VBW of spectrum analyzer to proper value.
4. Repeat above procedures until all frequencies measured were complete.

6.3 Test Results

The plot(s) of power density was presented hereinafter as reference.

Left Antenna: Page 21

Right Antenna: Page 22

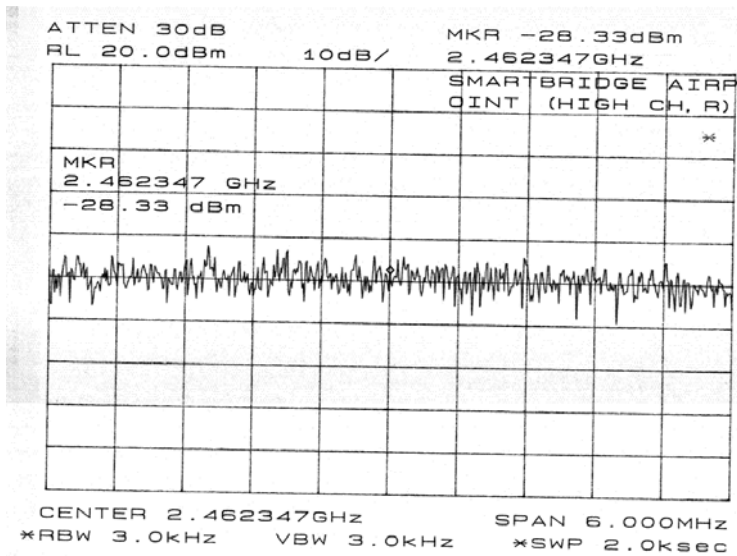
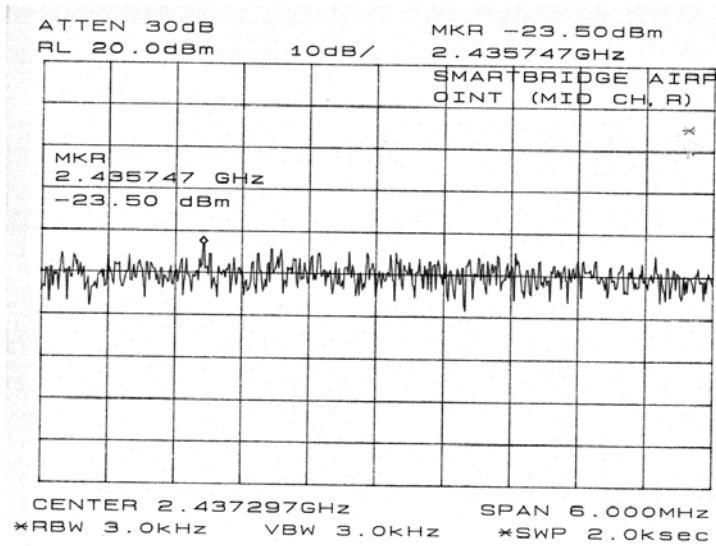
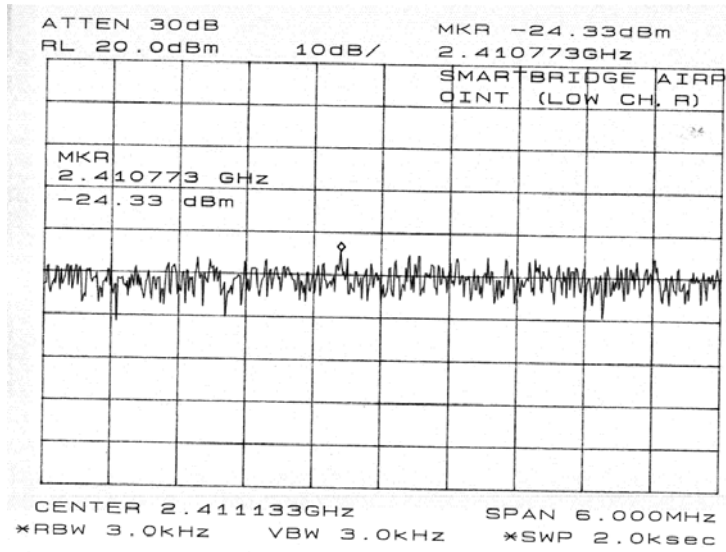

7 - 6DB BANDWIDTH

7.1 Standard Applicable

According to §15.247(a)(2), for direct sequence systems, the minimum 6dB bandwidth shall be at least 500 kHz.

7.2 Measurement Procedure

1. Check the calibration of the measuring instrument using either an internal calibrator or a known signal from an external generator.
2. Position the EUT without connection to measurement instrument. Turn on the EUT and connect it to measurement instrument. Then set it to any one convenient frequency within its operating range. Set a reference level on the measuring instrument equal to the highest peak value.
3. Measure the frequency difference of two frequencies that were attenuated 6 dB from the reference level. Record the frequency difference as the emission bandwidth.
4. Repeat above procedures until all frequencies measured were complete.

7.3 Test Result

The plot(s) of 6dB Bandwidth was presented hereinafter as reference.

Left antenna: Page 24

Right Antenna: Page 25

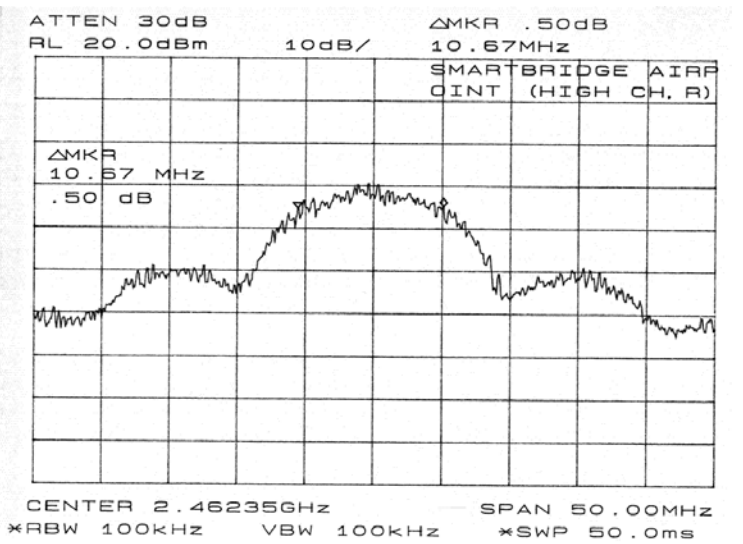
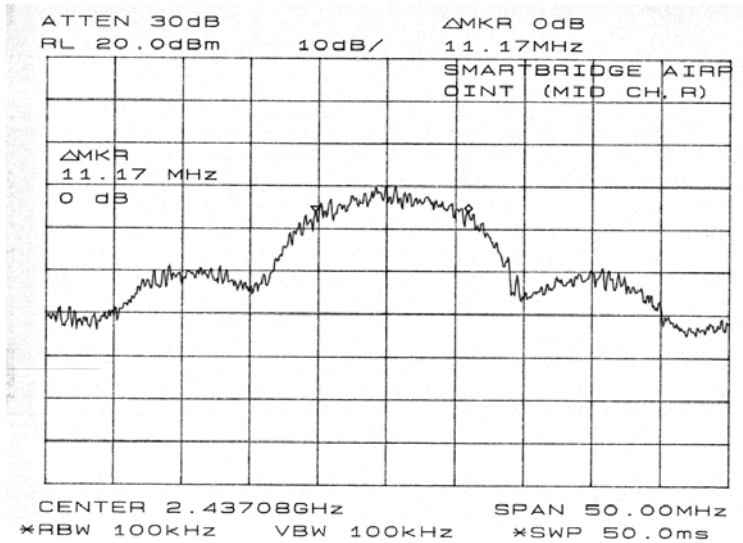
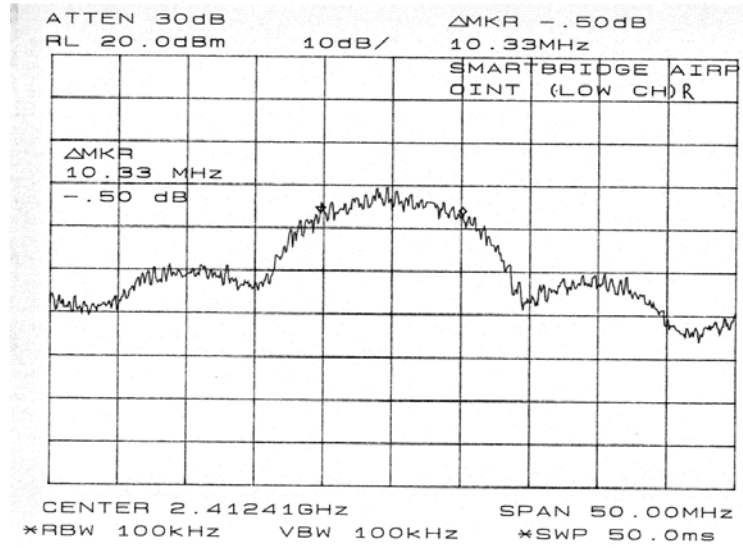

8 - 100 KHZ BANDWIDTH OF BAND EDGES MEASUREMENT

8.1 Standard Applicable

According to §15.247(c), if *any* 100 kHz bandwidth outside these frequency bands, the radio frequency power that is produced by the modulation products of the spreading sequence, the information sequence and the carrier frequency shall be either at least 20 dB below that in any 100 kHz bandwidth within the band that contains the highest level of the desired power or shall not exceed the general levels specified in § 15.209(a), whichever results in the lesser attenuation.

8.2 Measurement Procedure

1. Check the calibration of the measuring instrument using either an internal calibrator or a known signal from an external generator.
2. Position the EUT without connection to measurement instrument. Turn on the EUT and connect its antenna terminal to measurement instrument via a low loss cable. Then set it to any one measured frequency within its operating range, and make sure the instrument is operated in its linear range.
3. Set both RBW and VBW of spectrum analyzer to 300 kHz with a convenient frequency span including 100kHz bandwidth from band edge.
4. Measure the highest amplitude appearing on spectral display and set it as a reference level. Plot the graph with marking the highest point and edge frequency.
5. Repeat above procedures until all measured frequencies were complete.

8.3 Test Results

The plot(s) of Band Edge Test Data was presented hereinafter as reference.

Left Antenna: Page 27

Right Antenna: Page 28

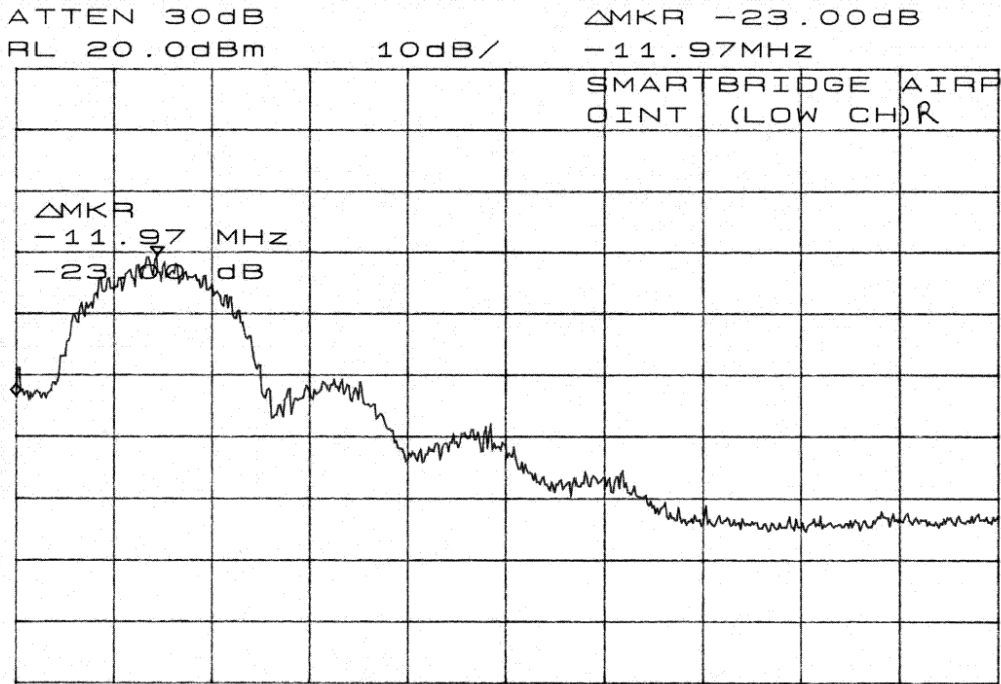

START 2.40000GHZ STOP 2.48350GHZ
*RBW 100KHZ VBW 100KHZ *SWP 50.0ms

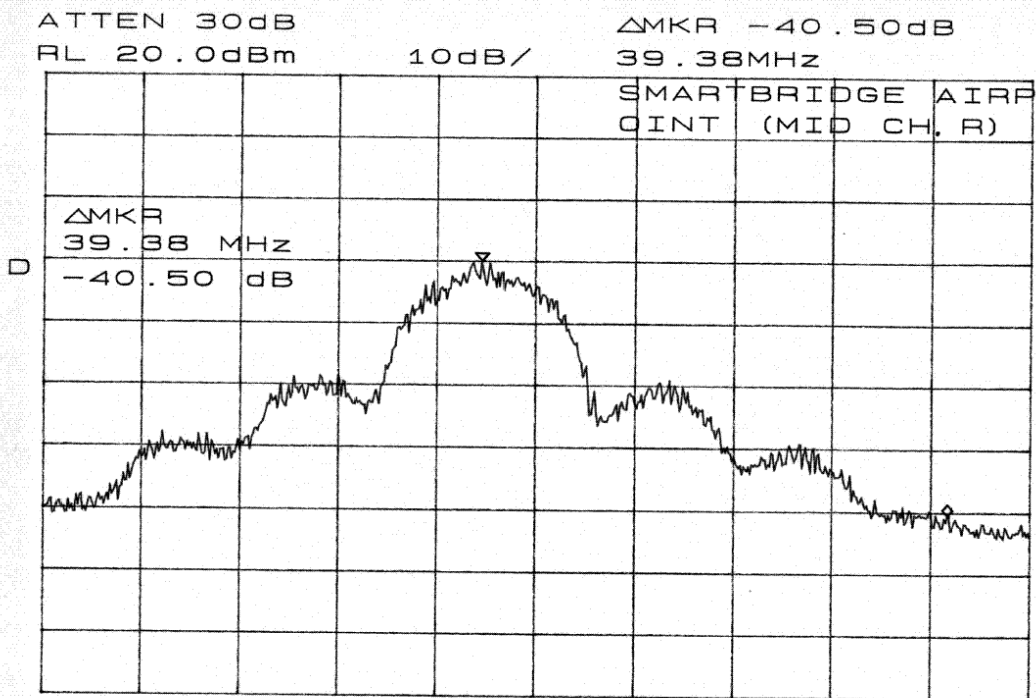

START 2.40000GHZ STOP 2.48350GHZ
*RBW 100KHZ VBW 100KHZ *SWP 50.0ms

9 - ANTENNA REQUIREMENT

9.1 Standard Applicable

For intentional device, according to § 15.203, an intentional radiator shall be designed to ensure that no antenna other than that furnished by the responsible party shall be used with the device.

And according to § 15.247 (1), if transmitting antennas of directional gain greater than 6 dBi are used the power shall be reduced by the amount in dB that the directional gain of the antenna exceeds 6 dBi.

9.2 Antenna Connected Construction

An intentional radiator shall be designed to ensure that no antenna other than that furnished by the responsible party shall be used with the device. The use of a permanently attached antenna or of an antenna that uses a unique coupling to the intentional radiator shall be considered sufficient to comply with the provisions of FCC related section.

10 - RF EXPOSURE

According to §15.247(b)(4) and §1.1307(b)(1), systems operating under the provisions of this section shall be operated in a manner that ensures that the public is not exposed to radio frequency energy level in excess of the Commission's guidelines.

According to §1.1310 and §2.1093 RF exposure is calculated.

Limits for Maximum Permissible Exposure (MPE)

Frequency Range (MHz)	Electric Field Strength (V/m)	Magnetic Field Strength (A/m)	Power Density (mW/cm ²)	Averaging Time (minute)
Limits for General Population/Uncontrolled Exposure				
0.3-1.34	614	1.63	*(100)	30
1.34-30	824/f	2.19/f	*(180/f ²)	30
30-300	27.5	0.073	0.2	30
300-1500	/	/	f/1500	30
1500-15000	/	/	1.0	30

f = frequency in MHz

* = Plane-wave equivalent power density

MPE Prediction

Predication of MPE limit at a given distance

Equation from page 18 of OET Bulletin 65, Edition 97-01

$$S = PG/4\pi R^2$$

Where: S = power density

P = power input to antenna

G = power gain of the antenna in the direction of interest relative to an isotropic radiator

R = distance to the center of radiation of the antenna

Maximum peak output power at antenna input terminal: 19.98 (dBm)

Maximum peak output power at antenna input terminal: 99.54 (mW)

Antenna Gain (typical): 0.5 (dBi)

Maximum antenna gain: 1.12 (numeric)

Prediction distance: 3 (cm)

Predication frequency: 2400 (MHz)

MPE limit for uncontrolled exposure at prediction frequency: 1 (mW/cm²)

Power density at predication frequency: 0.98 (mW/cm²)

Maximum allowable antenna gain: 1.13 (numeric)

Maximum allowable antenna gain: 0.53 (numeric)

Test Result

The predicted power density level at 3 cm is 0.98mW/cm². This is below the uncontrolled exposure limit of 1mW/cm² at 2400 MHz.

The EUT is used at least 20cm away from user's body, so it is determined as mobile equipment.

11 - SPURIOUS RADIATED EMISSION DATA

11.1 Measurement Uncertainty

All measurements involve certain levels of uncertainties, especially in field of EMC. The factors contributing to uncertainties are spectrum analyzer, cable loss, antenna factor calibration, antenna directivity, antenna factor variation with height, antenna phase center variation, antenna factor frequency interpolation, measurement distance variation, site imperfections, mismatch (average), and system repeatability.

Based on NIS 81, The Treatment of Uncertainty in EMC Measurements, the best estimate of the uncertainty of a radiation emissions measurement at BACL is ± 4.0 dB.

11.2 EUT Setup

The radiated emission tests were performed in the open area 3-meter test site, using the setup in accordance with the ANSI C63.4 - 1992. The specification used was the FCC 15 Subpart C limits.

The EUT was connected with the host PC system. The host PC system was placed on the center of the back edge on the test table. The modem and the monitor were placed on the right side of the host PC system, and the printer was placed on the left side of the host PC system. The rear of the EUT and peripherals were placed flushed with the rear of the tabletop.

The keyboard was placed directly in front of the monitor, flushed with the front of tabletop. The mouse was placed next to the keyboard, flushed with the back of keyboard.

The spacing between the peripherals was 10 centimeters.

External I/O cables were draped along the edge of the test table and bundle when necessary.

The host PC system was connected with 110Vac/60Hz power source.

11.3 Spectrum Analyzer Setup

According to FCC Rules, 47 CFR §15.33 (a) (1), the system was tested to 25GHz.

During the radiated emission test, the spectrum analyzer was set with the following configurations:

Start Frequency	30 MHz
Stop Frequency	25GHz
Sweep Speed	Auto
IF Bandwidth	1 MHz
Video Bandwidth	1 MHz
Quasi-Peak Adapter Bandwidth.....	120 kHz
Quasi-Peak Adapter Mode.....	Normal
Resolution Bandwidth.....	1MHz

11.4 Test Procedure

For the radiated emissions test, the Host PC system and all support equipment power cords were connected to the AC floor outlet since the power supply used in the EUT did not provide an accessory power outlet.

Maximizing procedure was performed on the six (6) highest emissions to ensure EUT compliance is with all installation combinations. All data was recorded in the peak detection mode. Quasi-peak readings was performed only when an emission was found to be marginal (within -4 dB μ V of specification limits), and are distinguished with a "Qp" in the data table.

11.5 Corrected Amplitude & Margin Calculation

The Corrected Amplitude is calculated by adding the Antenna Factor and Cable Factor, and subtracting the Amplifier Gain from the Amplitude reading. The basic equation is as follows:

$$\text{Corr. Ampl.} = \text{Indicated Reading} + \text{Antenna Factor} + \text{Cable Factor} - \text{Amplifier Gain}$$

The "Margin" column of the following data tables indicates the degree of compliance with the applicable limit. For example, a margin of -7dB μ V means the emission is 7dB μ V below the maximum limit for Class B. The equation for margin calculation is as follows:

$$\text{Margin} = \text{Corr. Ampl.} - \text{Class B Limit}$$

11.6 Summary of Test Results

According to the data in section 11.7, the EUT complied with the FCC Title 47, Part 15, Subpart C, section 15.205, 15.207, and 15.247, and had the worst margin of:

-0.3 dB μ V at 4824.13 MHz in the Vertical polarization, Low Channel, 30 MHz to 25GHz, 3 meters

-0.6 dB μ V at 4876.74 MHz in the Horizontal polarization, Middle Channel, 30 MHz to 25GHz, 3 meters

-0.6 dB μ V at 4924.00 MHz in the Vertical polarization, High Channel, 30 MHz to 25GHz, 3 meters

-1.0 dB μ V at 125.00 MHz in the Vertical polarization, Unintentional Emission, 30 MHz to 1000MHz, 3 meters

11.7 Final Test Result

Low Channel, 30MHz to 25GHz, 3 meters

INDICATED			TABLE	ANTENNA		CORRECTION FACTOR			CORRECTED AMPLITUDE	FCC 15 Subpart C	
Frequency MHz	Ampl. dBµV/m	Comments	Angle Degree	Height Meter	Polar H/V	Antenna dBµV/m	Cable dB	Amp. dB	Corr. Ampl. dBµV/m	Limit dBµV/m	Margin dB
4824.13	46.3	/	270	1.0	V	32.5	4.9	30.0	53.7	54.0	-0.3
7232.48	42.5	/	270	1.0	V	35.1	5.6	30.0	53.2	54.0	-0.8
4824.13	45.8	/	315	1.0	H	32.5	4.9	30.0	53.2	54.0	-0.8
7232.48	32.5	/	135	1.0	H	35.1	5.6	30.0	43.2	54.0	-10.8

Middle Channel, 30MHz to 25GHz, 3 meters

INDICATED			TABLE	ANTENNA		CORRECTION FACTOR			CORRECTED AMPLITUDE	FCC 15 Subpart C	
Frequency MHz	Ampl. dBµV/m	Comments	Angle Degree	Height Meter	Polar H/V	Antenna dBµV/m	Cable dB	Amp. dB	Corr. Ampl. dBµV/m	Limit dBµV/m	Margin dB
4876.74	46.0	/	225	1.0	V	32.5	4.9	30.0	53.4	54.0	-0.6
7316.69	42.0	/	225	1.0	V	35.1	5.6	30.0	52.7	54.0	-1.3
4876.74	44.2	/	315	1.0	H	32.5	4.9	30.0	51.6	54.0	-2.4
7316.69	34.2	/	315	1.0	H	35.1	5.6	30.0	44.9	54.0	-9.1

High Channel, 30MHz to 25GHz, 3 meters

INDICATED			TABLE	ANTENNA		CORRECTION FACTOR			CORRECTED AMPLITUDE	FCC 15 Subpart C	
Frequency MHz	Ampl. dBµV/m	Comments	Angle Degree	Height Meter	Polar H/V	Antenna dBµV/m	Cable dB	Amp. dB	Corr. Ampl. dBµV/m	Limit dBµV/m	Margin dB
4924.00	46.0	/	225	1.2	V	32.5	4.9	30.0	53.4	54.0	-0.6
7385.93	42.5	/	225	1.0	V	35.1	5.6	30.0	53.2	54.0	-0.8
4924.00	43.0	/	45	1.0	H	32.5	4.9	30.0	50.4	54.0	-3.6
7385.93	35.2	/	45	1.0	H	35.1	5.6	30.0	45.9	54.0	-8.1

Unintentional Emission, 30MHz to 1000MHz, 3 meters

INDICATED		TABLE	ANTENNA		CORRECTION FACTOR			CORRECTED AMPLITUDE	FCC 15 Class B	
Frequency MHz	Ampl. dBμV/m	Angle Degree	Height Meter	Polar H/ V	Antenna dBμV/m	Cable dB	Amp. dB	Corr. Ampl. dBμV/m	Limit dBμV/m	Margin dB
125.00	53.4	225	1.0	V	12.3	1.8	25.0	42.5	43.5	-1.0
959.99	43.8	225	2.5	H	24.7	4.2	28.0	44.7	46.0	-1.3
132.00	50.8	270	1.2	V	12.6	2.0	25.0	40.4	43.5	-3.1
225.00	50.5	45	1.5	H	12.1	3.9	25.0	41.5	46.0	-4.5
899.90	38.8	180	1.0	H	24.8	2.7	25.0	41.3	46.0	-4.7
400.00	45.2	45	1.0	H	16.5	2.9	25.0	39.6	46.0	-6.4
351.99	47.7	135	2.0	H	15.5	4.3	29.0	38.5	46.0	-7.5
180.00	42.7	90	1.2	V	13.6	4.0	25.0	35.3	43.5	-8.2
967.99	40.0	180	1.0	H	25.2	4.8	26.0	44.0	54.0	-10.0

12 - CONDUCTED EMISSIONS TEST DATA

12.1 Measurement Uncertainty

All measurements involve certain levels of uncertainties, especially in field of EMC. The factors contributing to uncertainties are spectrum analyzer, cable loss, and LISN.

Based on NIS 81, The Treatment of Uncertainty in EMC Measurements, the best estimate of the uncertainty of any conducted emissions measurement at BAEL is ± 2.4 dB.

12.2 EUT Setup

The measurement was performed at the **Open Area Test Site**, using the same setup per ANSI C63.4 - 1992 measurement procedure. The specification used was FCC 15 Subpart B limits.

The EUT was connected with the host PC system. The host PC system was placed on the center of the back edge on the test table. The modem and the monitor were placed on the right side of the host PC system, and the printer was placed on the left side of the host PC system. The rear of the EUT and peripherals were placed flushed with the rear of the tabletop.

The keyboard was placed directly in front of the monitor, flushed with the front of tabletop. The mouse was placed next to the keyboard, flushed with the back of keyboard.

The spacing between the peripherals was 10 centimeters.

Input / Output cables were draped along the edge of the test table and bundle when necessary.

The host PC system was connected with 110Vac/60Hz power source.

12.3 Spectrum Analyzer Setup

The spectrum analyzer was set with the following configurations during the conduction test:

Start Frequency.....	450 kHz
Stop Frequency.....	30 MHz
Sweep Speed.....	Auto
IF Bandwidth.....	10 kHz
Video Bandwidth.....	10 kHz
Quasi-Peak Adapter Bandwidth.....	9 kHz
Quasi-Peak Adapter Mode	Normal

12.4 Test Procedure

During the conducted emission test, the power cord of the host system was connected to the auxiliary outlet of the first LISN.

Maximizing procedure was performed on the six (6) highest emissions of each modes tested to ensure EUT is compliant with all installation combination.

All data was recorded in the peak detection mode. Quasi-peak readings were only performed when an emission was found to be marginal (within -4 dB μ V of specification limits). Quasi-peak readings are distinguished with a "Qp".

12.5 Summary of Test Results

According to the data in section 12.6, the EUT complied with the FCC Conducted margin for a Class B device, with the *worst* margin reading of:

-1.0 dB μ V at 28.330 MHz in the **Neutral** mode, smartBridges Pte Ltd power adapter, M/N: SMA210-2112C, S/N: 00000148, 450kHz - 30 MHz

12.6 Conducted Emissions Test Data

LINE CONDUCTED EMISSIONS				FCC CLASS B	
Frequency MHz	Amplitude dB μ V	Detector Qp/Ave/Peak	Phase Line/Neutral	Limit dB μ V	Margin dB
28.330	47.0	Peak	Neutral	48	-1.0
18.230	46.0	Peak	Neutral	48	-2.0
27.340	45.7	Peak	Line	48	-2.3
18.720	44.5	Peak	Line	48	-3.5
2.370	44.3	Peak	Line	48	-3.7
2.320	43.8	Peak	Neutral	48	-4.2

12.7 Plot of Conducted Emissions Test Data

Plot(s) of Conducted Emissions Test Data is presented hereinafter as reference.

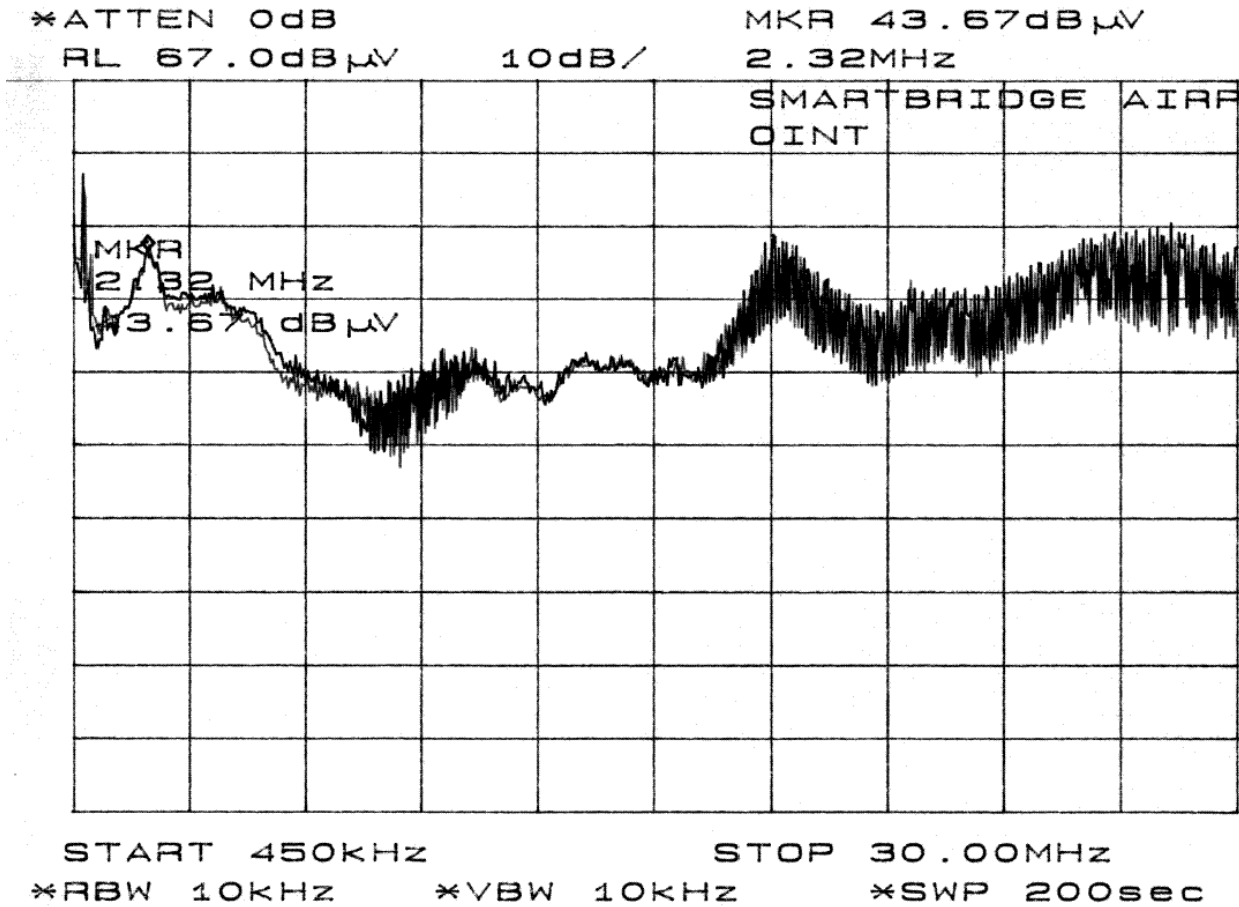

13 - PROCESSING GAIN

According to §15.247(e), the processing gain of a direct sequence system shall be at least 10 dB. The processing gain represents the improvement to the received signal-to-noise ratio, after filtering to the information bandwidth, from the spreading/dispreading function.

13.1 Brief Explanations on Processing Gain Data

Please refer to the attached file.

13.2 Test Data for Processing Gain

Please refer the attached file.

13.3 Test Setup - Processing Gain

Please refer to the attached file.