



**FCC 47 CFR PART 15 SUBPART C AND ANSI C63.4:2003
TEST REPORT**

For

TireHawk TPMS Kit

Model : TB-X04C

**Data Applies To : TB-X02B ; TB-X02C ; TB-X04B ;
TP-X00B ; TP-X00C**

Trade Name : VISIONWARE



Issued for

Visionware Technology Inc.

**4F-7, No. 77, Sec. 2, Keelung Rd., Xinyi Dist., Taipei,
Taiwan, R.O.C.**

Issued by

**Compliance Certification Services Inc.
No.11, Wu-Gong 6th Rd., Wugu Industrial Park,
New Taipei City 248, Taiwan (R.O.C.)**

**<http://www.ccsrf.com>
service@ccsrf.com**

Issued Date: October 25, 2012



Note: This report shall not be reproduced except in full, without the written approval of Compliance Certification Services Inc. This document may be altered or revised by Compliance Certification Services Inc. personnel only, and shall be noted in the revision section of the document. The client should not use it to claim product endorsement by TAF or any government agencies. The test results of this report relate only to the tested sample identified in this report.



Revision History

Rev.	Issue Date	Revisions	Effect Page	Revised By
00	10/25/2012	Initial Issue	All Page 62	Victoria Liu



TABLE OF CONTENTS

TITLE	PAGE NO.
1. TEST REPORT CERTIFICATION	4
2. EUT DESCRIPTION	5-6
3. DESCRIPTION OF TEST MODES	7
4. TEST METHODOLOGY	8
5. FACILITIES AND ACCREDITATION	8
5.1 FACILITIES	8
5.2 EQUIPMENT	8
5.3 TABLE OF ACCREDITATIONS AND LISTINGS.....	9
5.4 MEASUREMENT UNCERTAINTY	10
6. SETUP OF EQUIPMENT UNDER TEST.....	11-13
7. FCC PART 15.247 REQUIREMENTS.....	14
7.1 6dB BANDWIDTH	14-19
7.2 MAXIMUM PEAK OUTPUT POWER	20-21
7.3 POWER SPECTRAL DENSITY	22-27
7.4 CONDUCTED SPURIOUS EMISSION	28-34
7.5 RADIATED EMISSION.....	35-53
7.6 CONDUCTED EMISSION.....	54-56
APPENDIX I MAXIMUM PERMISSIBLE EXPOSURE	57-58
APPENDIX II SETUP PHOTOS	59-62



1. TEST REPORT CERTIFICATION

Applicant : Visionware Technology Inc..
Address : 4F-7, No. 77, Sec. 2, Keelung Rd., Xinyi Dist., Taipei,
 Taiwan, R.O.C.
Equipment Under Test : TireHawk TPMS Kit
Model : TB-X04C
Data Applies To : TB-X02B ; TB-X02C ; TB-X04B ; TP-X00B ; TP-X00C
Trade Name : VISIONWARE 
Tested Date : August 09 ~ October 23, 2012

APPLICABLE STANDARD	
Standard	Test Result
FCC Part 15 Subpart C AND ANSI C63.4:2003	PASS

WE HEREBY CERTIFY THAT: The above equipment has been tested by Compliance Certification Services Inc., and found compliance with the requirements set forth in the technical standards mentioned above. The results of testing in this report apply only to the product/system, which was tested. Other similar equipment will not necessarily produce the same results due to production tolerance and measurement uncertainties.

Approved by:

Reviewed by:

Miller Lee
Section Manager

Gina Lo
Section Manager

**2. EUT DESCRIPTION**

Product Name	TireHawk TPMS Kit
Model Number	TB-X04C
Data Applies To	TB-X02B ; TB-X02C ; TB-X04B ; TP-X00B ; TP-X00C
Identify Number	T120809L08
Received Date	August 09, 2012
Frequency Range	IEEE 802.11b/g : 2412MHz ~ 2462MHz
Transmit Power	IEEE 802.11b : 18.68 dBm (0.0738W) IEEE 802.11g : 24.15 dBm (0.2600W)
Channel Spacing	IEEE 802.11b/g : 5MHz
Channel Number	IEEE 802.11b/g : 11 Channels
Transmit Data Rate	IEEE 802.11b : 11, 5.5, 2, 1 Mbps IEEE 802.11g : 54, 48, 36, 24, 18, 12, 9, 6 Mbps
Type of Modulation	IEEE 802.11b : DSSS (CCK, DQPSK, DBPSK) IEEE 802.11g : OFDM (64QAM, 16QAM, QPSK, BPSK)
Antenna Type	Wireless Repeater(2.4GHz) : PCB Antenna, Antenna Gain 1.45 dBi
Power Rating	Wireless Repeater : 5Vdc (From car charger) External Tire Sensor : 3Vdc (From battery)
Test Voltage	120Vac, 60Hz
I/O Port	USB Port x 1, Mini USB Port x 1
Signal Cable	Shielded USB cable 1m x 1 Non-shielded telescopic USB cable 0.6m x 1

Car Charger :

No.	Manufacturer	Model No.	Power Input	Power Output
1	e13	039860	12Vdc	5Vdc



The difference of the series model :

Product Series	Model Number	Difference
TireHawk TPMS Kit	Bright ⁺ TB-X02B	Firmware
	Bright ⁺ TB-X02C	
	Bright ⁺ TB-X04B	
	Bright ⁺ TB-X04C	
	Power ⁺ TP-X00B	
	Power ⁺ TP-X00C	

Remark :

1. For more details, please refer to the User's manual of the EUT.
2. This submittal(s) (test report) is intended for FCC ID:PVM-VTITHBJ9040 filing to comply with Section 15.207, 15.209 and 15.247 of the FCC Part 15, Subpart C Rules.
3. The model TB-X04C sensor : 4 was considered the main model for testing.



3. DESCRIPTION OF TEST MODES

Conducted Emission / Radiated Emission Test (Below 1 GHz)

1. The following test modes were scanned during the preliminary test:

No.	Pre-Test Mode
1	Normal Operating (Not telescopic USB cable)
2	Normal Operating (Telescopic USB cable)

2. After the preliminary scan, the following test mode was found to produce the highest emission level.

Final Test Mode		
Emission	Radiated Emission	Normal Operating (Not telescopic USB cable)
	Conducted Emission	NA

Remark : Then, the above highest emission mode of the configuration of the EUT and cable was chosen for all final test items.

Conducted / Radiated Emission Test (Above 1 GHz)

The EUT had been tested under operating condition.

There are three channels have been tested as following :

Channel	Frequency (MHz)
Low	2412
Middle	2437
High	2462

IEEE 802.11b mode : 1Mbps data rate (worst case) were chosen for full testing.

IEEE 802.11g mode : 6Mbps data rate (worst case) were chosen for full testing.

Remark : The field strength of spurious emission was measured in the following position: EUT stand-up position(Z axis), lie-down position(X, Y axis). The worst emission was found in lie-down position(Y axis) and the worst case was recorded.



4. TEST METHODOLOGY

The tests documented in this report were performed in accordance with ANSI C63.4:2003 and FCC CFR 47, 15.207, 15.209 and 15.247

5. FACILITIES AND ACCREDITATION

5.1 FACILITIES

All measurement facilities used to collect the measurement data are located at

No.11, Wu-Gong 6th Rd., Wugu Industrial Park,
New Taipei City 248, Taiwan (R.O.C.)

The sites are constructed in conformance with the requirements of ANSI C63.4:2003 and CISPR 22. All receiving equipment conforms to CISPR 16-1-1, CISPR 16-1-2, CISPR 16-1-3, CISPR 16-1-4, CISPR 16-1-5.

5.2 EQUIPMENT

Radiated emissions are measured with one or more of the following types of linearly polarized antennas: tuned dipole, biconical, log periodic, bi-log, and/or ridged waveguide, horn. Spectrum analyzers with pre-selectors and quasi-peak detectors are used to perform radiated measurements.



Conducted emissions are measured with Line Impedance Stabilization Networks and EMI Test Receivers.

Calibrated wideband preamplifiers, coaxial cables, and coaxial attenuators are also used for making measurements.

All receiving equipment conforms to CISPR Publication 16-1, "Radio Interference Measuring Apparatus and Measurement Methods."



5.3 TABLE OF ACCREDITATIONS AND LISTINGS

Country	Agency	Scope of Accreditation	Logo
USA	FCC	3M Semi Anechoic Chamber (FCC MRA: TW1039) to perform FCC Part 15 measurements	 FCC MRA: TW1039
Taiwan	TAF	LP0002, RTTE01, FCC Method-47 CFR Part 15 Subpart C, D, E, RSS-210, RSS-310 IDA TS SRD, AS/NZS 4268, AS/NZS 4771, TS 12.1 & 12.2, ETSI EN 300 440-1, ETSI EN 300 440-2, ETSI EN 300 328, ETSI EN 300 220-1, ETSI EN 300 220-2, ETSI EN 301 893, ETSI EN 301 489-1/3/7/17 FCC OET Bulletin 65 + Supplement C, EN 50360, EN 50361, EN 50371, RSS 102, EN 50383, EN 50385, EN 50392, IEC 62209, CNS 14958-1, CNS 14959 FCC Method -47 CFR Part 15 Subpart B IEC / EN 61000-3-2, IEC / EN 61000-3-3, IEC / EN 61000-4-2/3/4/5/6/8/11	
Canada	Industry Canada	3M Semi Anechoic Chamber (IC 2324G-1 / IC 2324G-2) to perform	 IC 2324G-1 IC 2324G-2

* No part of this report may be used to claim or imply product endorsement by A2LA or any agency of the US Government.



5.4 MEASUREMENT UNCERTAINTY

The following table is for the measurement uncertainty, which is calculated as per the document CISPR 16-4-2.

PARAMETER	UNCERTAINTY
Powerline Conducted Emission	+/- 1.2575
3M Semi Anechoic Chamber / 30M~200M	+/- 4.0138
3M Semi Anechoic Chamber / 200M~1000M	+/- 3.9483
3M Semi Anechoic Chamber / 1G~8G	+/- 2.5975
3M Semi Anechoic Chamber / 8G~18G	+/- 2.6112
3M Semi Anechoic Chamber / 18G~26G	+/- 2.7389
3M Semi Anechoic Chamber / 26G~40G	+/- 2.9683

This uncertainty represents an expanded uncertainty expressed at approximately the 95% confidence level using a coverage factor of $k=2$.

Consistent with industry standard (e.g. CISPR 22, clause 11, Measurement Uncertainty) determining compliance with the limits shall be base on the results of the compliance measurement. Consequently the measure emissions being less than the maximum allowed emission result in this be a compliant test or passing test.

The acceptable measurement uncertainty value without requiring revision of the compliance statement is base on conducted and radiated emissions being less than U_{CISPR} which is 3.6dB and 5.2dB respectively. CCS values (called U_{Lab} in CISPR 16-4-2) is less than U_{CISPR} as shown in the table above. Therefore, MU need not be considered for compliance.



6. SETUP OF EQUIPMENT UNDER TEST

SUPPORT EQUIPMENT

No.	Product	Manufacturer	Model No.	Serial No.	FCC ID
1	Android Phone	Sony Ericsson	XPERIA	---	DoC
2	Notebook PC	HP	ProBook 4421s	CNF03242PJ	DoC

No.	Signal cable description
1	Shielded USB cable, 1m x 1 (From EUT to charge phone)
2	Shielded RS-232 cable, 1.2m x 1

SETUP DIAGRAM FOR TESTS

EUT & peripherals setup diagram is shown in appendix setup photos.

EUT OPERATING CONDITION

RF Mode:

1. Set up whole system for test as shown on diagram.
2. Notebook PC install TERA term free software
3. Notebook PC connected to EUT with RS-232 cable and run TERA term program
4. When the EUT ready, Key-in the command
5. Command :

TX Mode:

TX B mode (CCK 1Mbps) test use default power set

- a. Ch1
radw 1
chw 1
drw 02
apcw 0
netw 2
ct 1
- b. Ch 6
radw 1
chw 6
drw 02
apcw 0
netw 2



ct 1
c. Ch 11
radw 1
chw 11
drw 02
apcw 1
netw 2
ct 1

TX G mode (OFDM 6Mbps) test use default power set

a. Ch1
radw 1
chw 1
drw 0c
apcw 0
netw 2
ct 2
b. Ch 6
radw 1
chw 6
drw 0c
apcw 0
netw 2
ct 2
c. Ch 11
radw 1
chw 11
drw 0c
apcw 0
netw 2
ct 2

Change power: (after loaded TX command)

Key-in : wir 7c (watch default power set)

wiw 7c set (the set mean power set < 0.5dB / 2 step>,least 2 step)

Ex: wir 7c (if watch power set = 6e)

wiw 7c 6e (power set = 6c < least 2 step >)



Default power set (test use power)

B-Low =68

B-Mid =6a

B-Hig(2462) =6e

G-Low =68

G-Mid =6a

G-Hig(2462) =6e

7. All of the functions are under run.

8. Start test.

Normal Mode:

1. Use Android Phone Download TireHawk APP From Internet.

2. Setup whole system for test as shown on diagram

3. Android phone use wifi link to EUT.

3. Use android phone open tireHawk APP.

4. All of the functions are under run.

5. Start test.



7. FCC PART 15.247 REQUIREMENTS

7.1 6dB BANDWIDTH

LIMITS

§ 15.247(a) (2) For direct sequence systems, the minimum 6dB bandwidth shall be at least 500kHz.

TEST EQUIPMENT

Name of Equipment	Manufacturer	Model	Serial Number	Calibration Due
Spectrum Analyzer	Agilent	E4446A	MY43360131	03/16/2013

Remark: Each piece of equipment is scheduled for calibration once a year.

TEST SETUP



TEST PROCEDURE

The transmitter output was connected to a spectrum analyzer. The bandwidth of the fundamental frequency was measured by spectrum analyzer with 100 KHz RBW and 300 KHz VBW. The 6dB bandwidth is defined as the total spectrum the power of which is higher than peak power minus 6dB.



TEST RESULTS

IEEE 802.11b Mode

Channel	Channel Frequency (MHz)	6dB Bandwidth (MHz)	Minimum Limit (kHz)	Pass / Fail
Low	2412	10.17	500	PASS
Middle	2437	10.17	500	PASS
High	2462	10.17	500	PASS

IEEE 802.11g Mode

Channel	Channel Frequency (MHz)	6dB Bandwidth (MHz)	Minimum Limit (kHz)	Pass / Fail
Low	2412	16.50	500	PASS
Middle	2437	16.50	500	PASS
High	2462	16.50	500	PASS



6dB BANDWIDTH

IEEE 802.11b Mode / CH Low

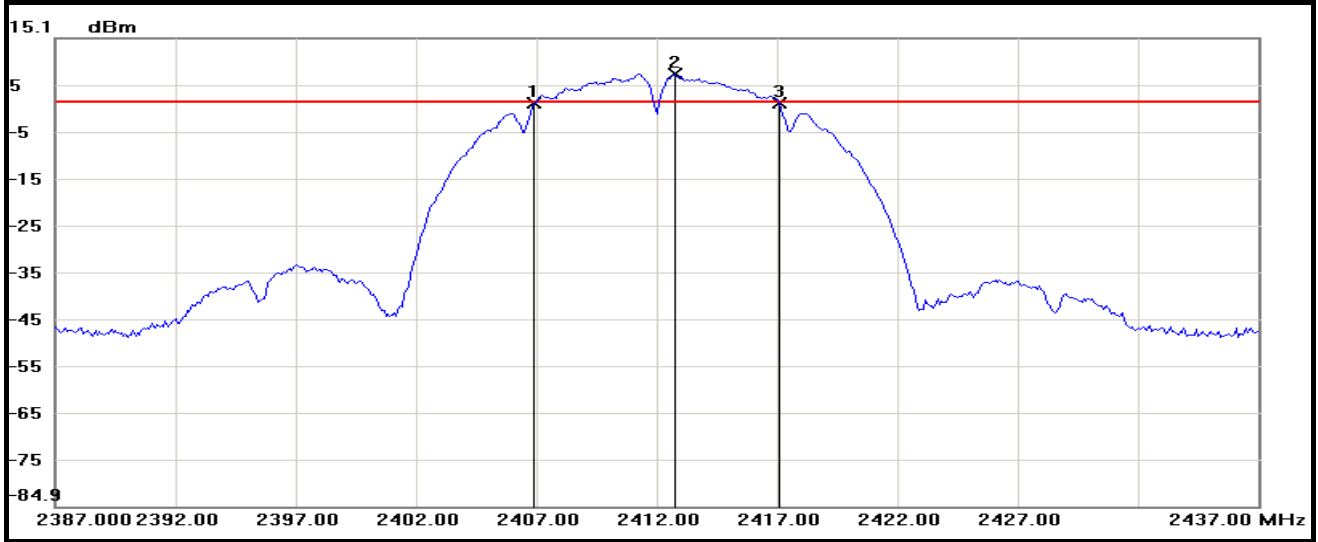

No.	Frequency(MHz)	Result(dBm)
1	2406.9167	1.28
2	2412.7500	7.46
3	2417.0833	1.23

IEEE 802.11b Mode / CH Middle

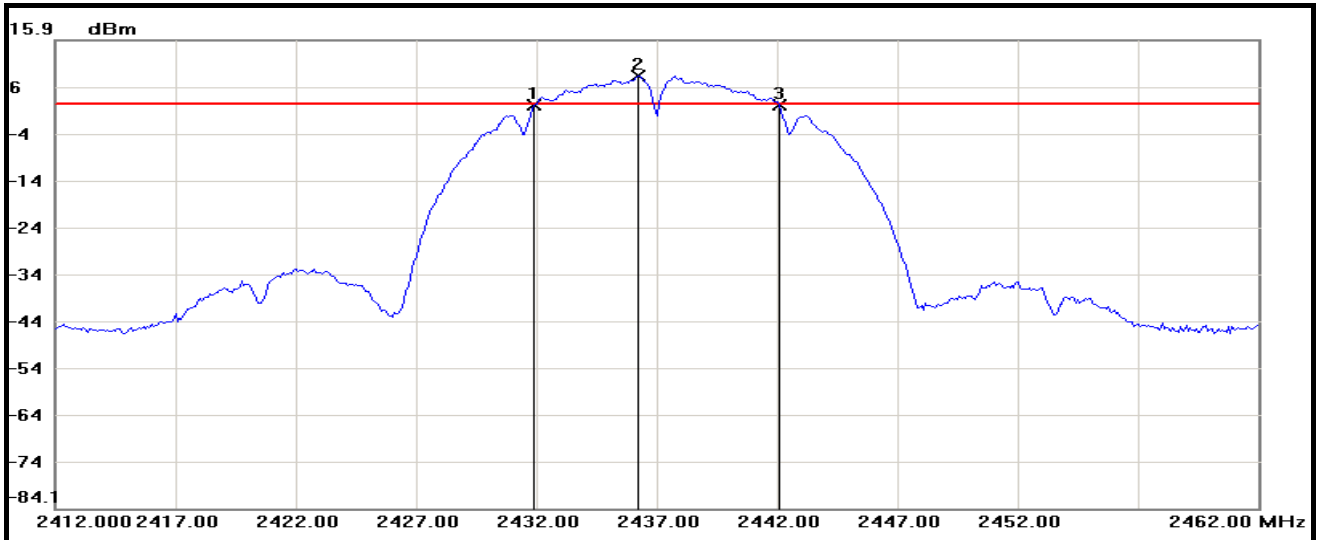

No.	Frequency(MHz)	Result(dBm)
1	2431.9167	2.02
2	2436.2500	8.24
3	2442.0833	1.95



IEEE 802.11b Mode / CH High

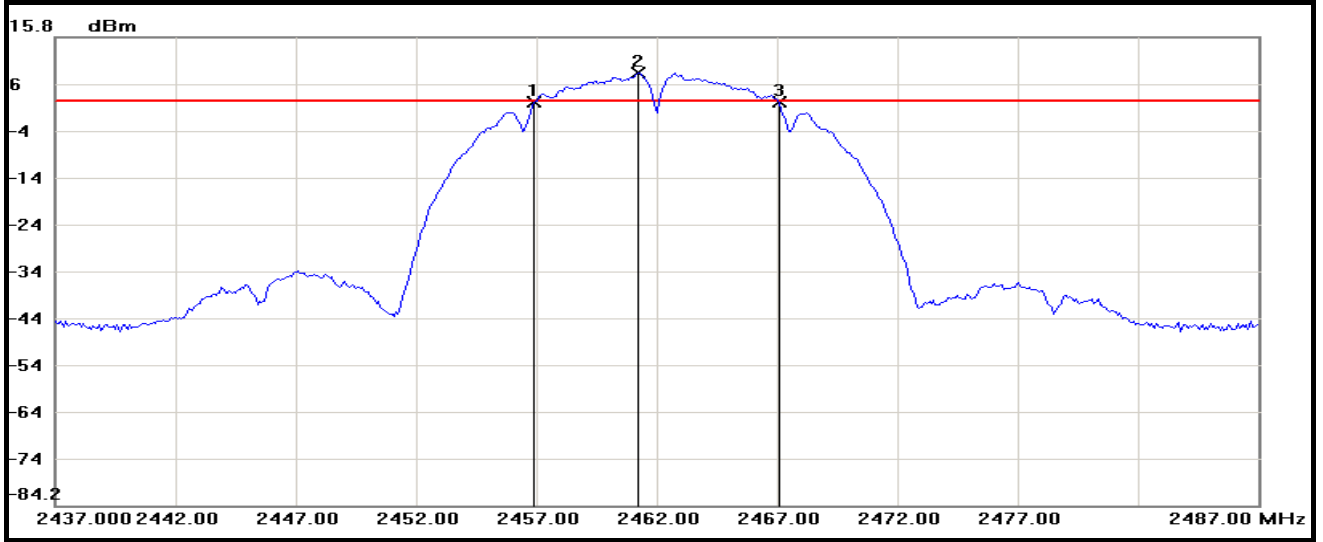

No.	Frequency(MHz)	Result(dBm)
1	2456.9167	2.05
2	2461.2500	8.23
3	2467.0833	1.88



IEEE 802.11g Mode / CH Low

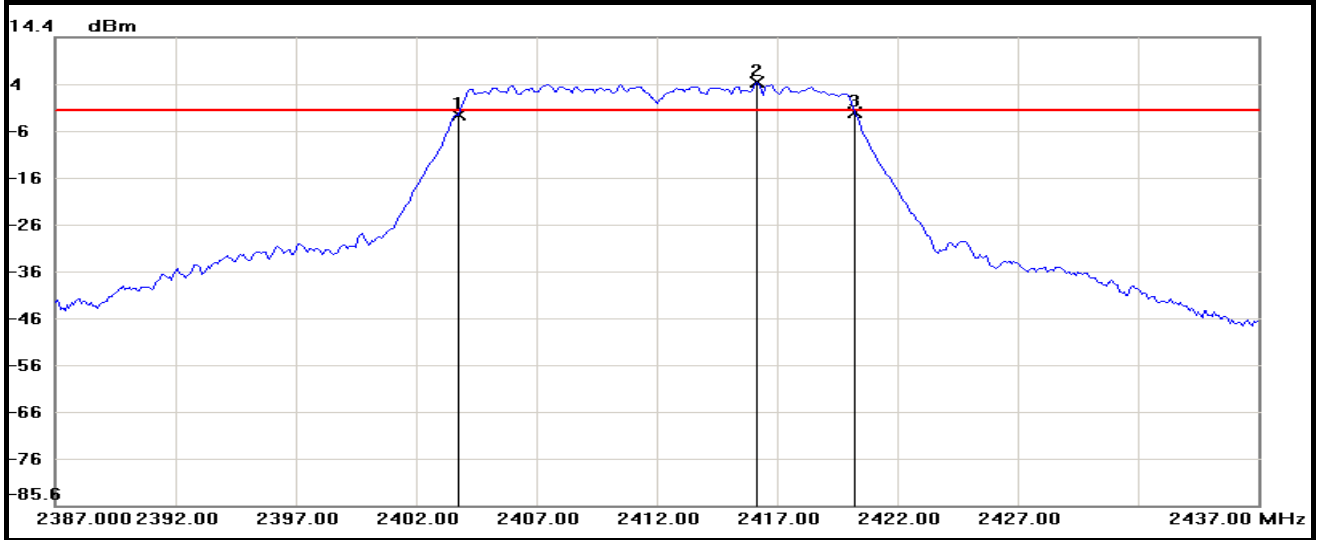

No.	Frequency(MHz)	Result(dBm)
1	2403.7500	-2.22
2	2416.1667	4.71
3	2420.2500	-1.79

IEEE 802.11g Mode / CH Middle

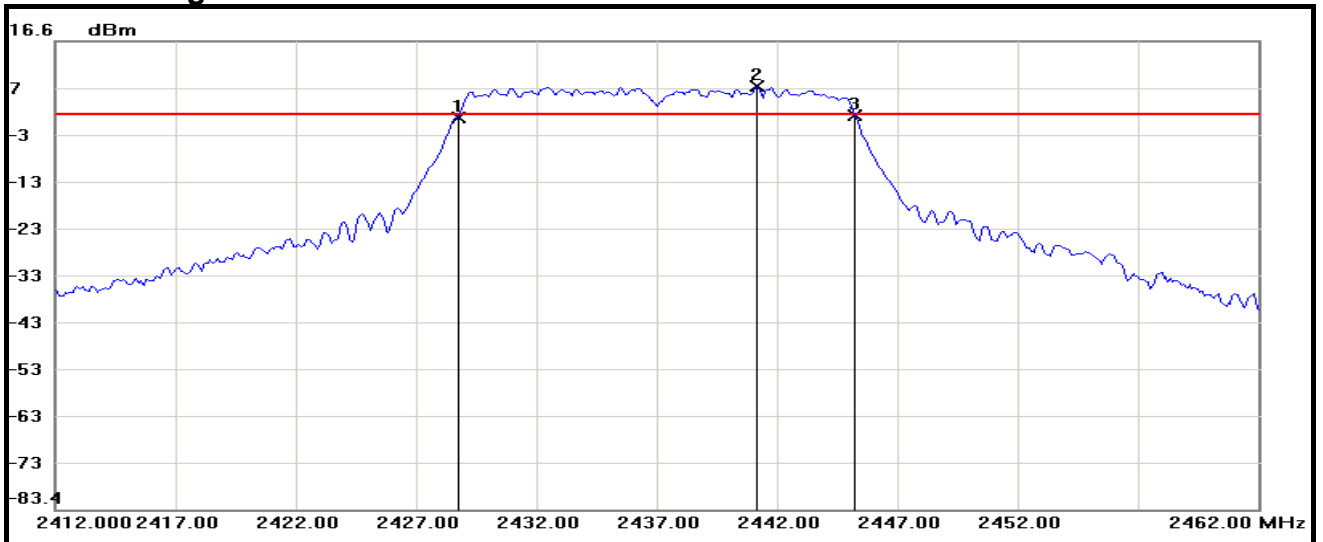

No.	Frequency(MHz)	Result(dBm)
1	2428.7500	0.33
2	2441.1667	7.00
3	2445.2500	0.70



IEEE 802.11g Mode / CH High

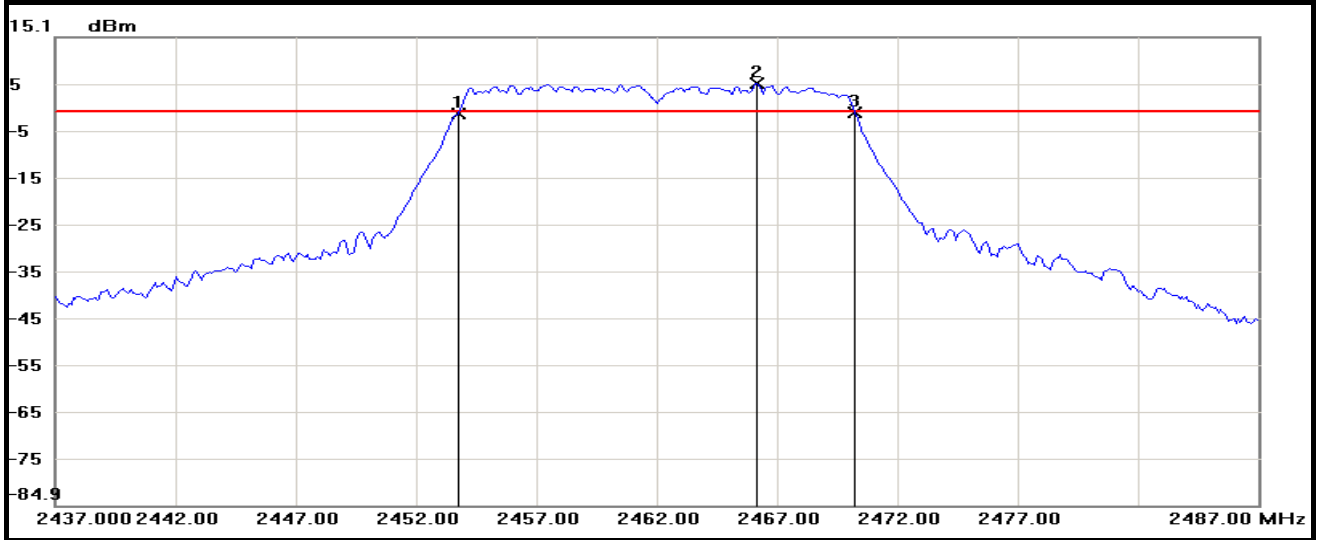

No.	Frequency(MHz)	Result(dBm)
1	2453.7500	-1.30
2	2466.1667	5.31
3	2470.2500	-1.07



7.2 MAXIMUM PEAK OUTPUT POWER

LIMITS

§ 15.247(b) The maximum peak output power of the intentional radiator shall not exceed the following :

§ 15.247(b) (3) For systems using digital modulation in the 902-928 MHz, 2400-2483.5 MHz, and 5725-5850 MHz bands : 1 watt.

§ 15.247(b) (4) Except as shown in paragraphs (c) of this section, if transmitting antennas of directional gain greater than 6 dBi are used the peak output power from the intentional radiator shall be reduced below the stated values in paragraphs (b)(1) or (b)(2), and (b)(3) of this section, as appropriate, by the amount in dB that the directional gain of the antenna exceeds 6 dBi.

TEST EQUIPMENT

Name of Equipment	Manufacturer	Model	Serial Number	Calibration Due
Power Meter	Anritsu	ML2495A	1012009	04/26/2013
Power Sensor	Anritsu	MA2411B	0917072	04/26/2013

Remark: Each piece of equipment is scheduled for calibration once a year.

TEST SETUP

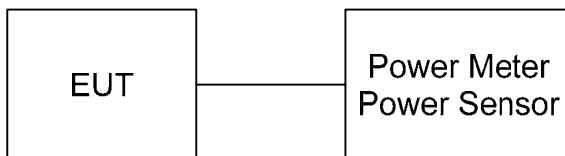

TEST PROCEDURE

The transmitter output is connected to the Power Meter. The Power Meter is set to the peak power detection.



TEST RESULTS

IEEE 802.11b Mode

Channel	Channel Frequency (MHz)	Peak Power		Peak Power Limit		Pass / Fail
		(dBm)	(W)	(dBm)	(W)	
Low	2412	18.42	0.0695	30	1	PASS
Middle	2437	18.66	0.0735	30	1	PASS
High	2462	18.68	0.0738	30	1	PASS

Remark:

1. At final test to get the worst-case emission at 1Mbps.
2. The cable assembly insertion loss of 10.5dB (including 10 dB pad and 0.5 dB cable) was Entered as an offset in the power meter to allow for direct reading of power.

IEEE 802.11g Mode

Channel	Channel Frequency (MHz)	Peak Power		Peak Power Limit		Pass / Fail
		(dBm)	(W)	(dBm)	(W)	
Low	2412	23.47	0.2223	30	1	PASS
Middle	2437	24.15	0.2600	30	1	PASS
High	2462	23.11	0.2046	30	1	PASS

Remark:

1. At final test to get the worst-case emission at 6Mbps.
2. The cable assembly insertion loss of 10.5dB (including 10 dB pad and 0.5 dB cable) was Entered as an offset in the power meter to allow for direct reading of power.



7.3 POWER SPECTRAL DENSITY

LIMITS

§ 15.247(e) For digitally modulated systems, the power spectral density conducted from the intentional radiator to the antenna shall not greater than 8 dBm in any 3 kHz band during any time interval of continuous transmission.

TEST EQUIPMENT

Name of Equipment	Manufacturer	Model	Serial Number	Calibration Due
Spectrum Analyzer	Agilent	E4446A	MY43360131	03/16/2013

Remark: Each piece of equipment is scheduled for calibration once a year.

TEST SETUP

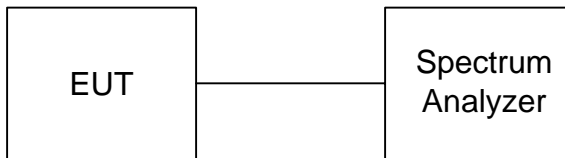

TEST PROCEDURE

The transmitter output was connected to the spectrum analyzer, the bandwidth of the fundamental frequency was measured with the spectrum analyzer using RBW = 3KHz and VBW = RBW, set sweep time = span / 3KHz.

The power spectral density was measured and recorded.

The sweep time is allowed to be longer than span / 3KHz for a full response of the mixer in the spectrum analyzer.



TEST RESULTS

IEEE 802.11b Mode

Channel	Channel Frequency (MHz)	Final RF Power Level in 3KHz BW (dBm)	Minimum Limit (dBm)	Pass / Fail
Low	2412	-10.29	8	PASS
Middle	2437	-9.69	8	PASS
High	2462	-9.68	8	PASS

Remark:

1. At final test to get the worst-case emission at 1Mbps.
2. The cable assembly insertion loss of 10.5dB (including 10 dB pad and 0.5 dB cable) was Entered as an offset in the spectrum analyzer to allow for direct reading of power.

IEEE 802.11g Mode

Channel	Channel Frequency (MHz)	Final RF Power Level in 3KHz BW (dBm)	Minimum Limit (dBm)	Pass / Fail
Low	2412	-15.54	8	PASS
Middle	2437	-13.39	8	PASS
High	2462	-15.03	8	PASS

Remark:

1. At final test to get the worst-case emission at 6Mbps.
2. The cable assembly insertion loss of 10.5dB (including 10 dB pad and 0.5 dB cable) was Entered as an offset in the spectrum analyzer to allow for direct reading of power.



POWER SPECTRAL DENSITY

IEEE 802.11b Mode / CH Low

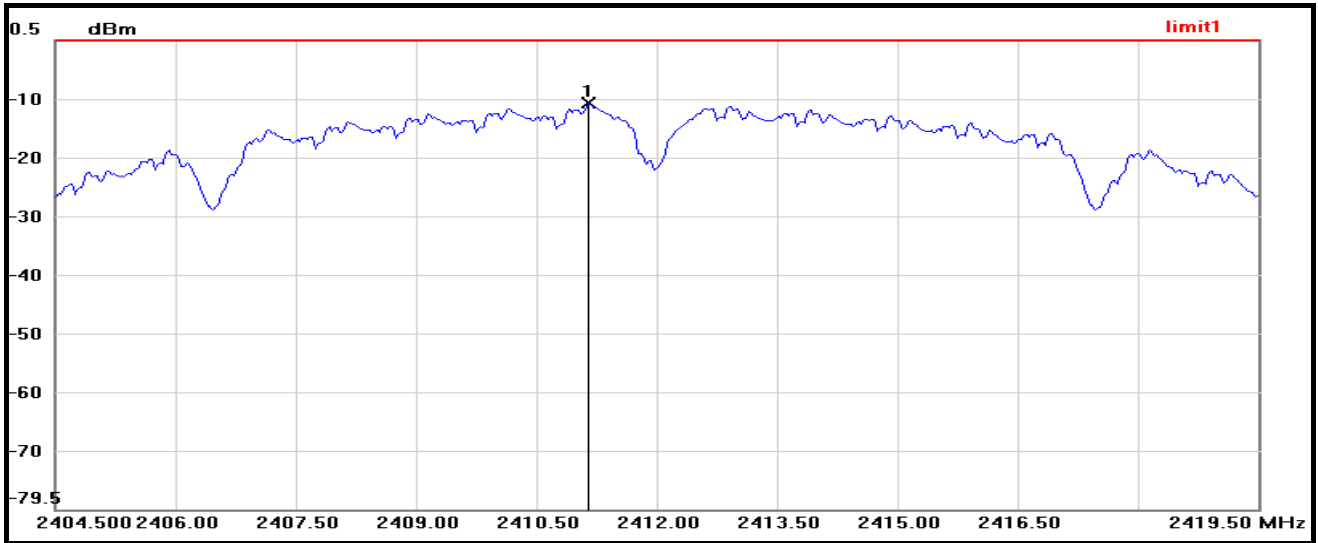

No.	Frequency(MHz)	Result(dBm)	Limit(dBm)	Margin(dBm)
1	2411.1500	-10.29	8.00	-18.29

IEEE 802.11b Mode / CH Middle

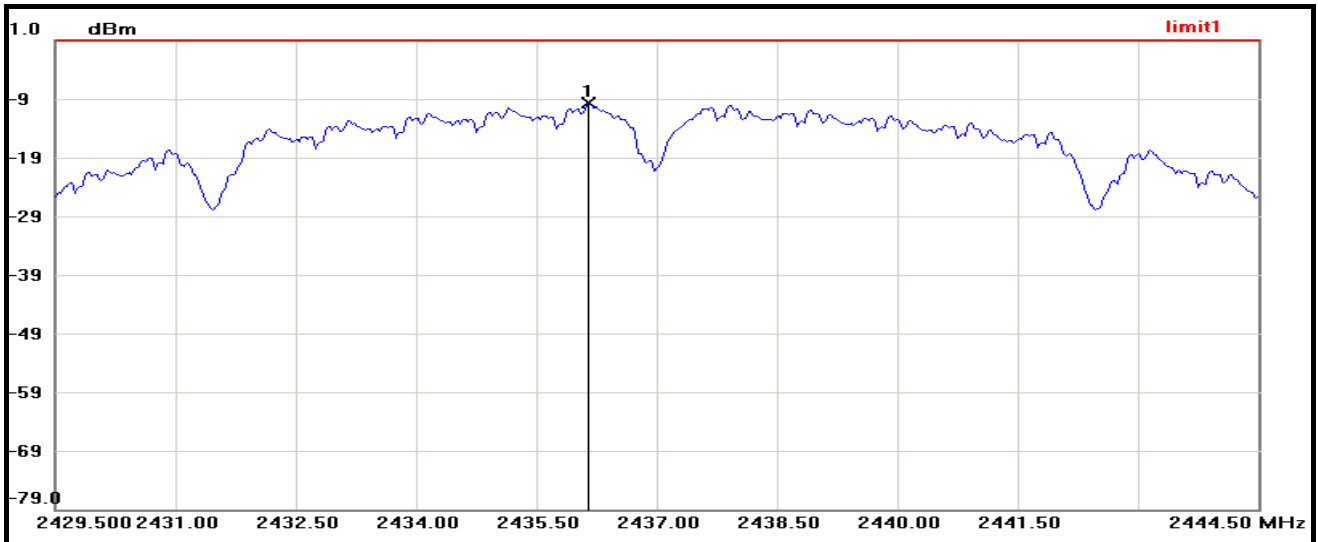

No.	Frequency(MHz)	Result(dBm)	Limit(dBm)	Margin(dBm)
1	2436.1500	-9.69	8.00	-17.69



IEEE 802.11b Mode / CH High

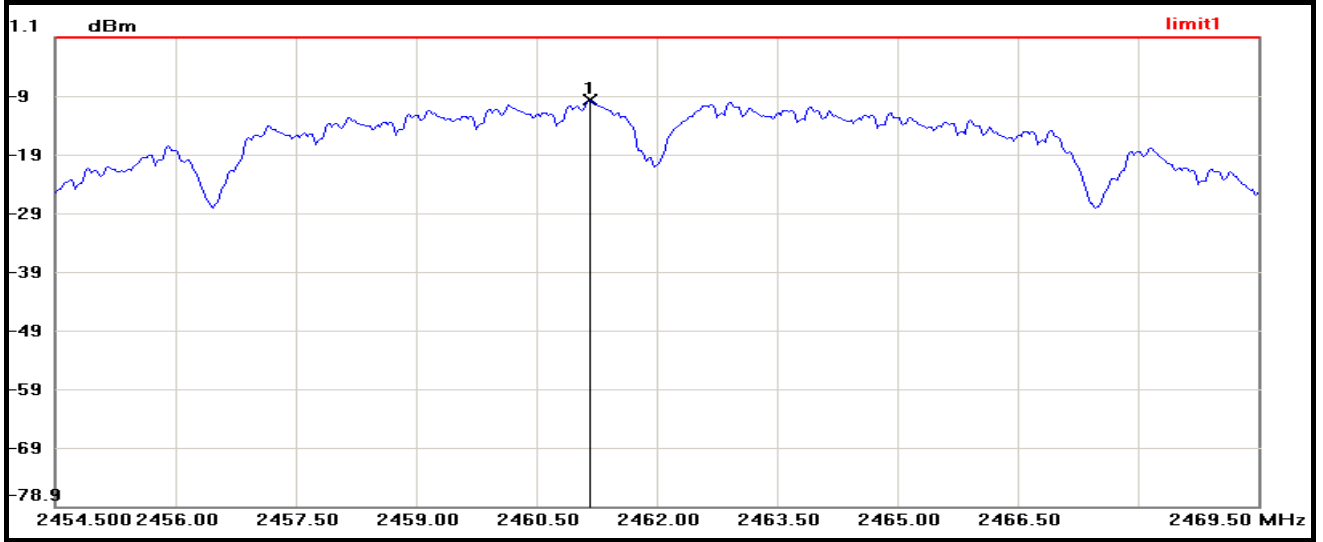

No.	Frequency(MHz)	Result(dBm)	Limit(dBm)	Margin(dBm)
1	2461.1750	-9.68	8.00	-17.68



IEEE 802.11g Mode / CH Low

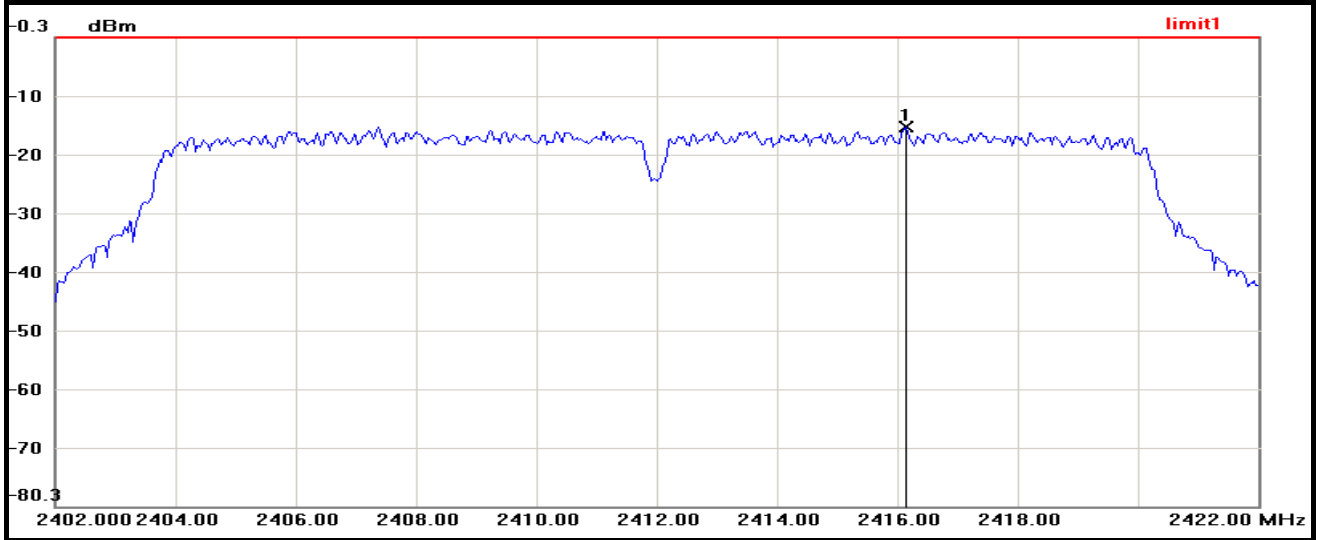

No.	Frequency(MHz)	Result(dBm)	Limit(dBm)	Margin(dBm)
1	2416.1333	-15.54	8.00	-23.54

IEEE 802.11g Mode / CH Middle

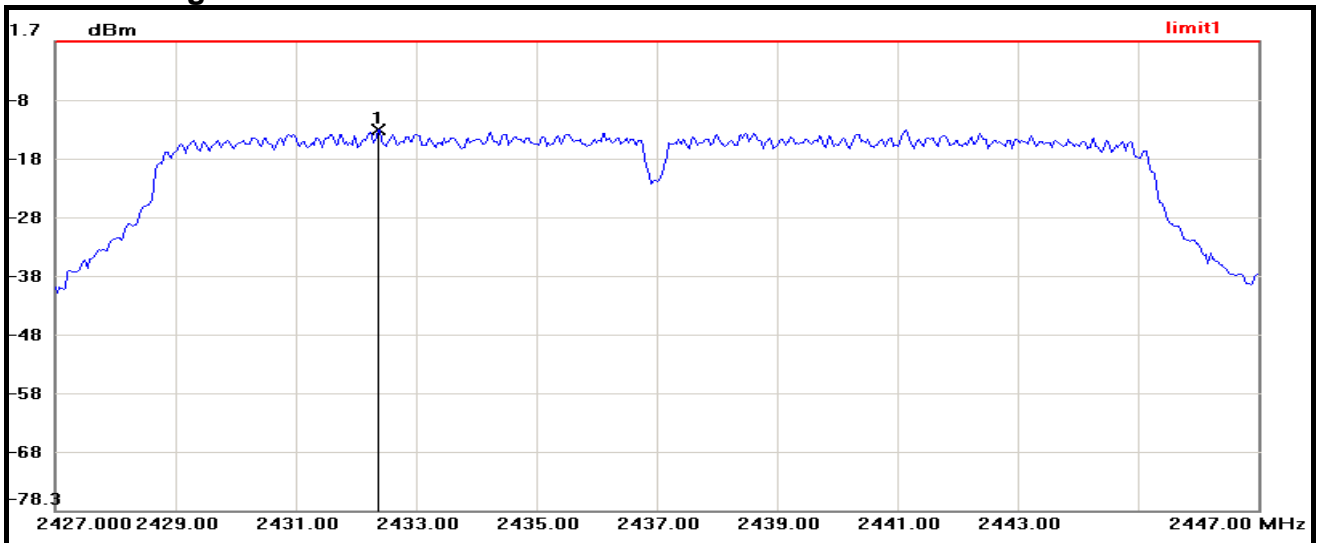

No.	Frequency(MHz)	Result(dBm)	Limit(dBm)	Margin(dBm)
1	2432.3667	-13.39	8.00	-21.39



IEEE 802.11g Mode / CH High

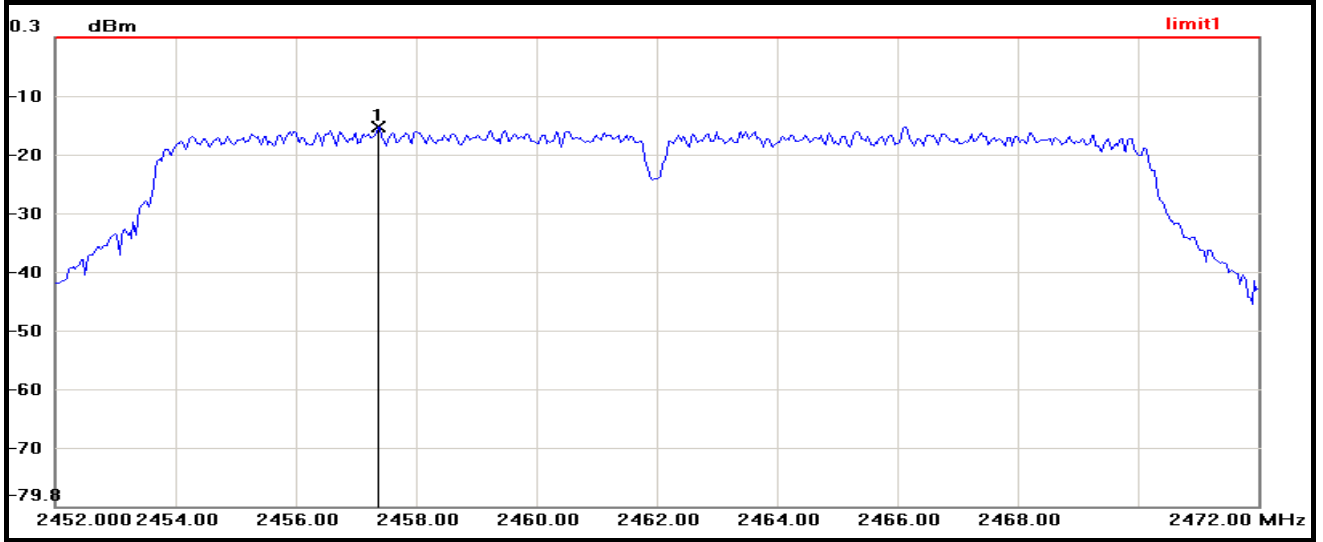

No.	Frequency(MHz)	Result(dBm)	Limit(dBm)	Margin(dBm)
1	2457.3667	-15.03	8.00	-23.03



7.4 CONDUCTED SPURIOUS EMISSION

LIMITS

§ 15.247(d) In any 100 kHz bandwidth outside the frequency band in which the spread spectrum intentional radiator is operating, the radio frequency power that is produced by the intentional radiator shall be at least 20 dB below that in the 100 kHz bandwidth within the band that contains the highest level of the desired power, based on either an RF conducted or a radiated measurement. Attenuation below the general limits specified in § 15.209(a) is not required. In addition, radiated emissions which fall in the restricted bands, as defined in § 15.205(a), must also comply with the radiated emission limits specified in § 15.209(a) (see § 15.205(c)).

TEST EQUIPMENT

Name of Equipment	Manufacturer	Model	Serial Number	Calibration Due
Spectrum Analyzer	Agilent	E4446A	MY43360131	03/16/2013

Remark: Each piece of equipment is scheduled for calibration once a year.

TEST SETUP

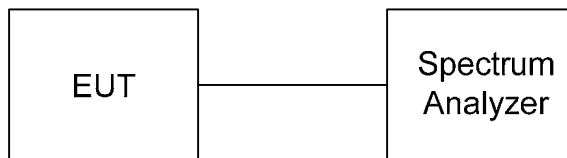

TEST PROCEDURE

The transmitter output is connected to a spectrum analyzer. The resolution bandwidth is set to 100 kHz. The video bandwidth is set to 300 kHz.

The spectrum from 30 MHz to 25 GHz is investigated with the transmitter set to the lowest, middle, and highest channels in the 2.4 GHz band.



TEST RESULTS

OUT-OF-BAND SPURIOUS EMISSIONS-CONDUCTED MEASUREMENT

IEEE 802.11b Mode / CH Low / 2.38GHz ~ 2.5GHz

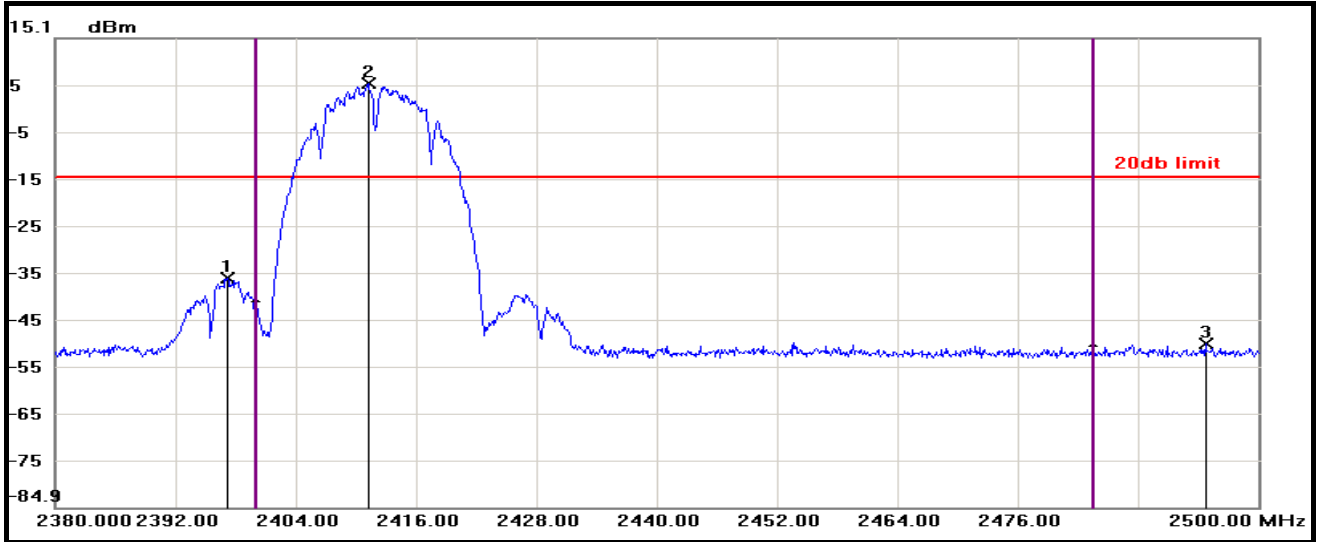

No.	Frequency(MHz)	Result(dBm)	Limit(dBm)	Margin(dBm)
1	2397.1600	-35.92	-14.44	-21.48
2	2411.2000	5.56	-14.44	20.00
3	2494.7200	-49.98	-14.44	-35.54

IEEE 802.11b Mode / CH Low / Full band

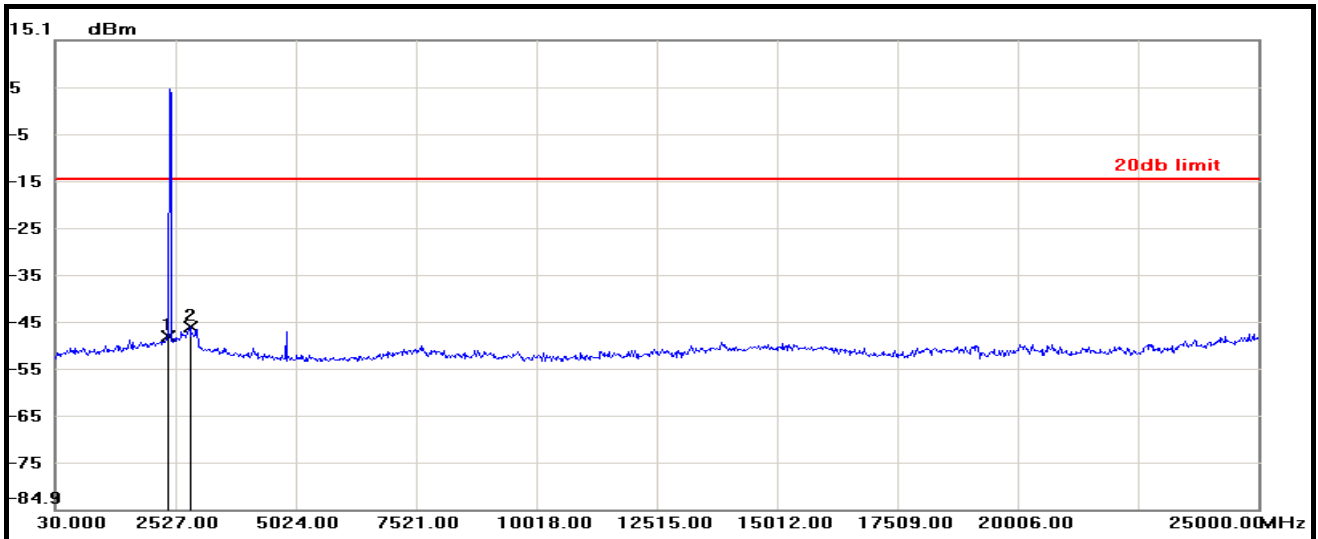

No.	Frequency(MHz)	Result(dBm)	Limit(dBm)	Margin(dBm)
1	2377.1800	-47.97	-14.44	-33.53
2	2826.6400	-45.97	-14.44	-31.53



IEEE 802.11b Mode / CH Middle / 2.38GHz ~ 2.5GHz

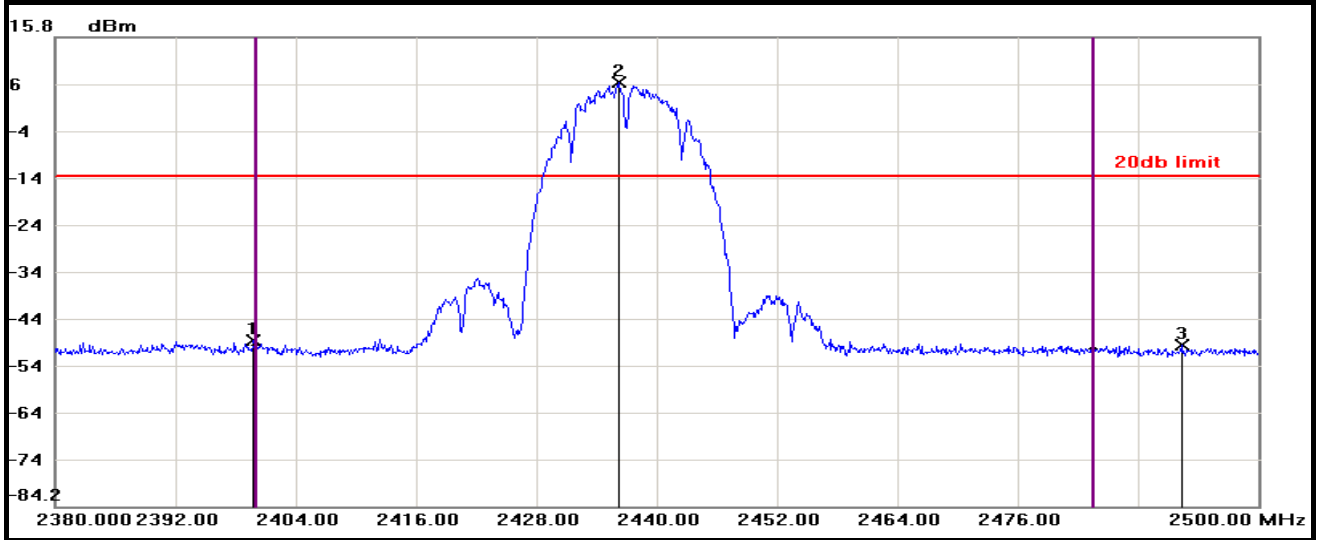

No.	Frequency(MHz)	Result(dBm)	Limit(dBm)	Margin(dBm)
1	2399.8000	-48.93	-13.80	-35.13
2	2436.1600	6.20	-13.80	20.00
3	2492.3200	-49.90	-13.80	-36.10

IEEE 802.11b Mode / CH Middle / Full band

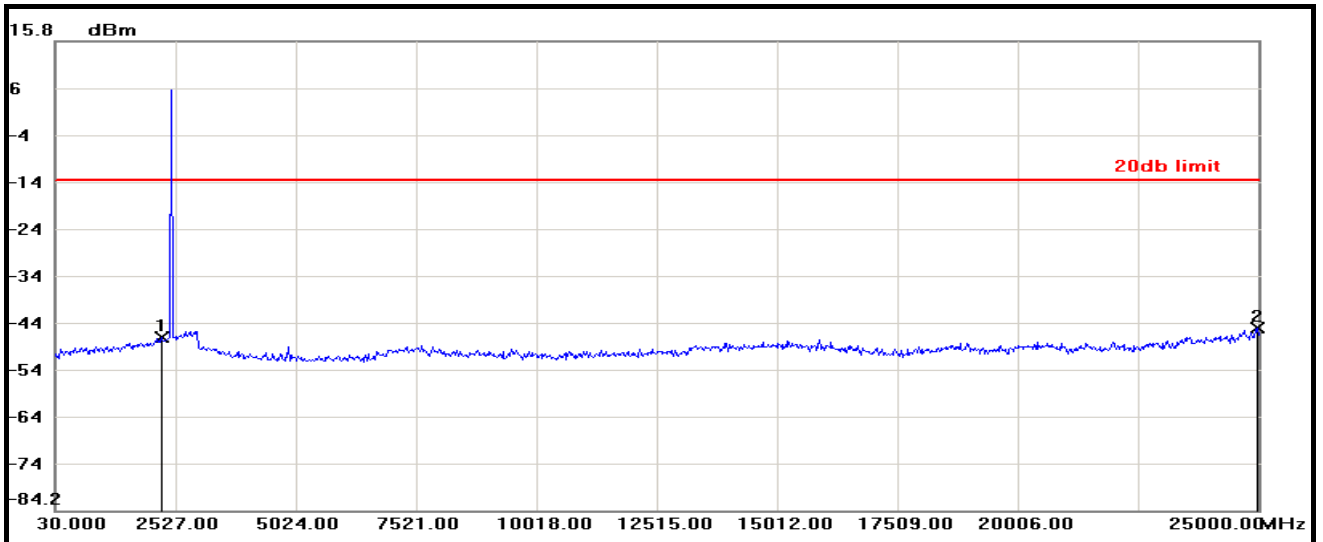

No.	Frequency(MHz)	Result(dBm)	Limit(dBm)	Margin(dBm)
1	2227.3600	-47.30	-13.80	-33.50
2	24975.0300	-45.38	-13.80	-31.58



IEEE 802.11b Mode / CH High / 2.38GHz ~ 2.5GHz

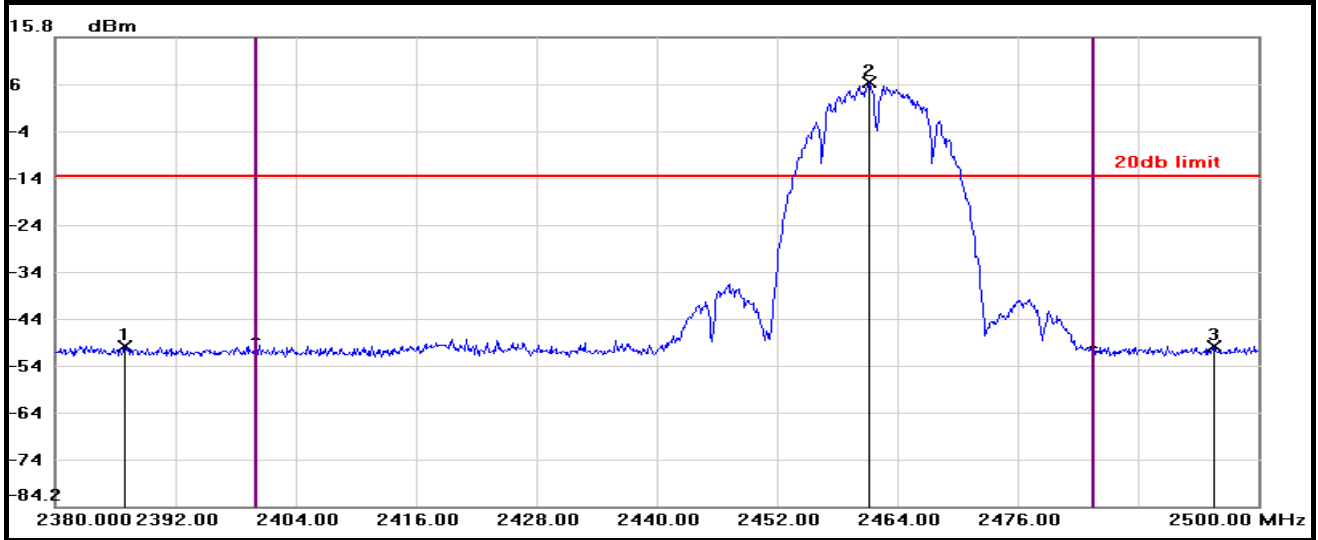

No.	Frequency(MHz)	Result(dBm)	Limit(dBm)	Margin(dBm)
1	2386.9600	-50.00	-13.74	-36.26
2	2461.1200	6.26	-13.74	20.00
3	2495.5600	-49.96	-13.74	-36.22

IEEE 802.11b Mode / CH High / Full band

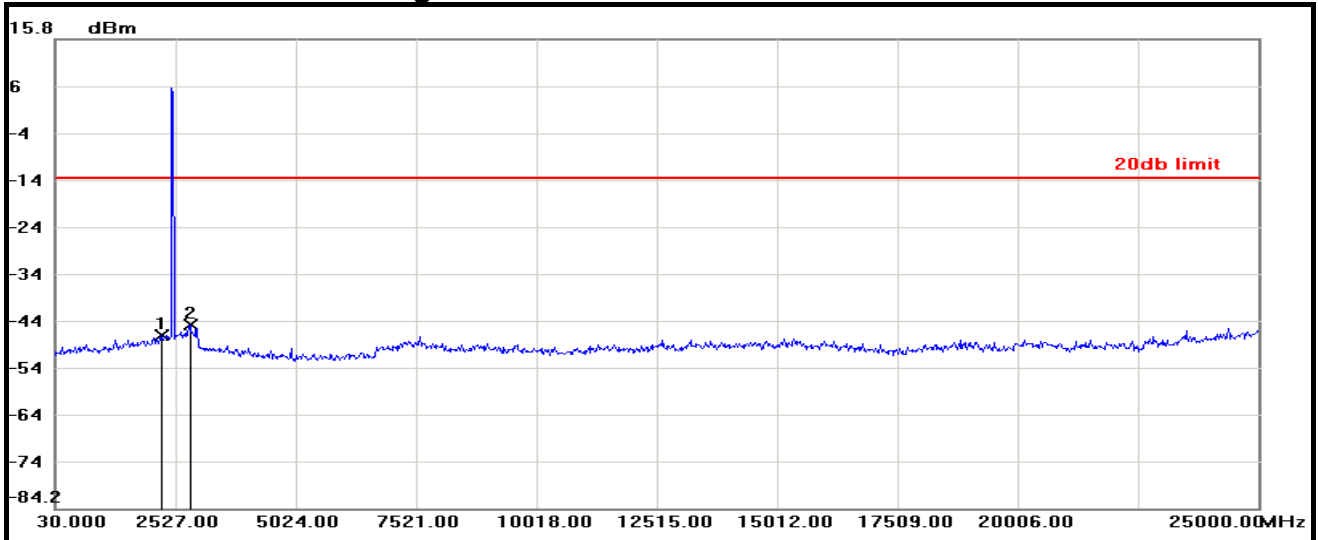

No.	Frequency(MHz)	Result(dBm)	Limit(dBm)	Margin(dBm)
1	2252.3300	-47.19	-13.74	-33.45
2	2826.6400	-45.08	-13.74	-31.34



IEEE 802.11g Mode / CH Low / 2.38GHz ~ 2.5GHz

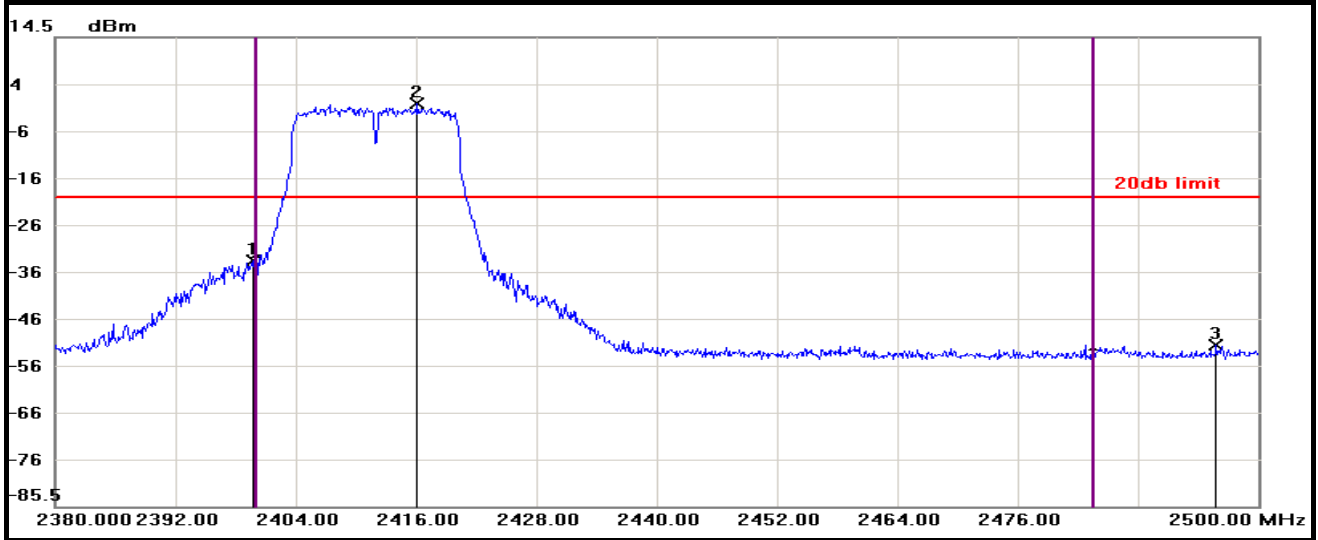

No.	Frequency(MHz)	Result(dBm)	Limit(dBm)	Margin(dBm)
1	2399.6800	-33.25	-19.71	-13.54
2	2416.1200	0.29	-19.71	20.00
3	2495.8000	-51.15	-19.71	-31.44

IEEE 802.11g Mode / CH Low / Full band

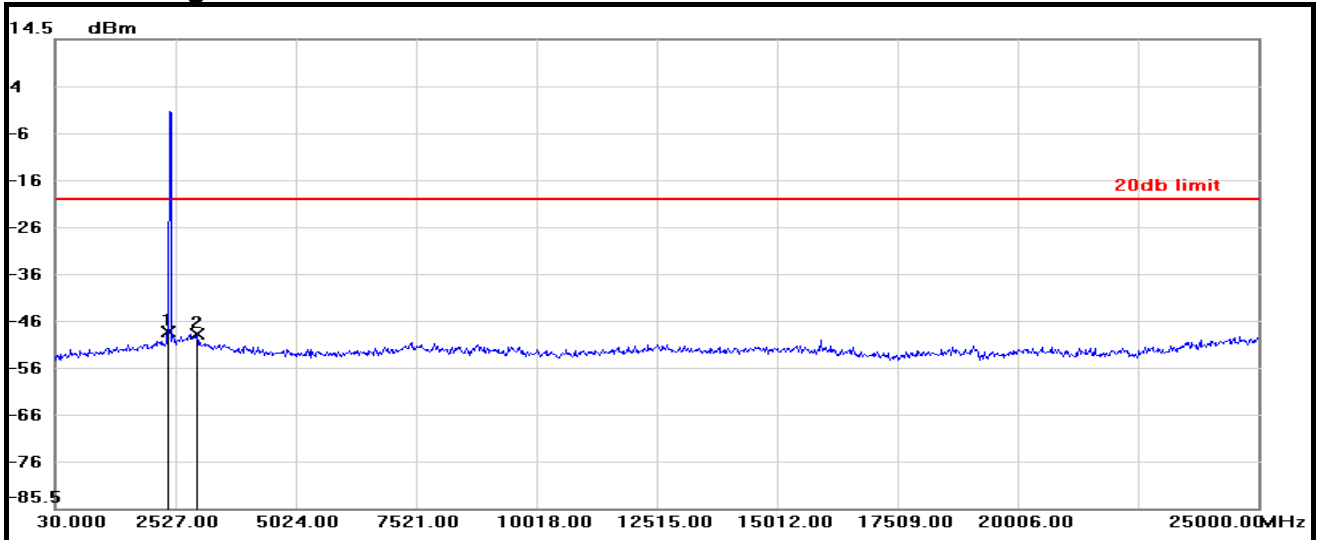

No.	Frequency(MHz)	Result(dBm)	Limit(dBm)	Margin(dBm)
1	2377.1800	-47.91	-19.71	-28.20
2	2976.4600	-48.32	-19.71	-28.61



IEEE 802.11g Mode / CH Middle / 2.38GHz ~ 2.5GHz

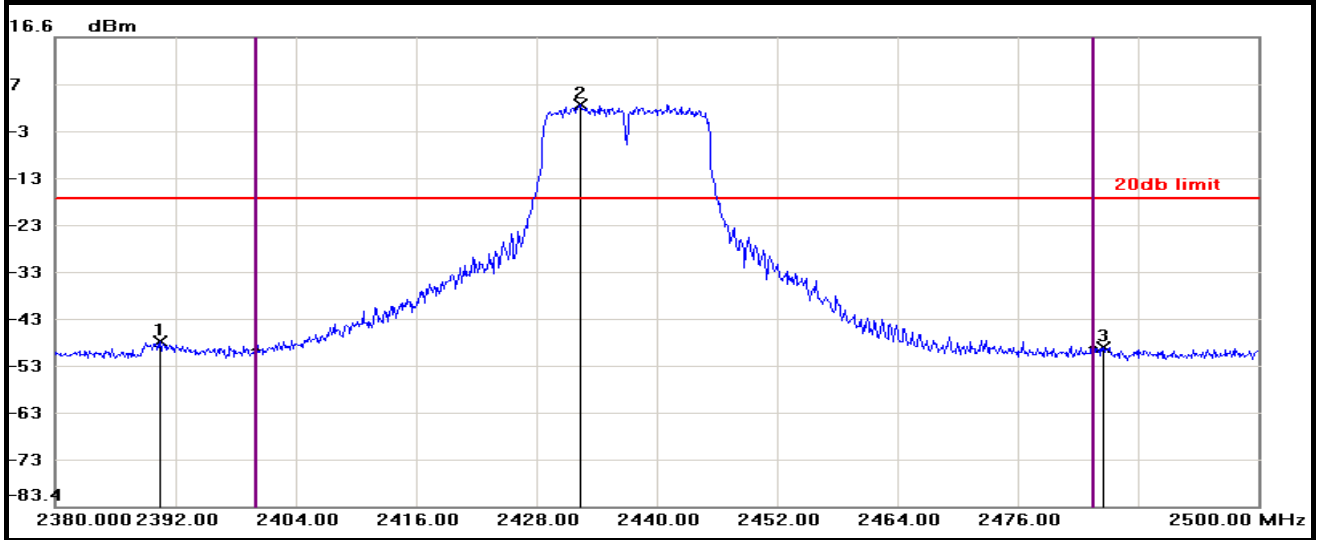

No.	Frequency(MHz)	Result(dBm)	Limit(dBm)	Margin(dBm)
1	2390.4400	-48.26	-17.77	-30.49
2	2432.4400	2.23	-17.77	20.00
3	2484.5200	-49.57	-17.77	-31.80

IEEE 802.11g Mode / CH Middle / Full band

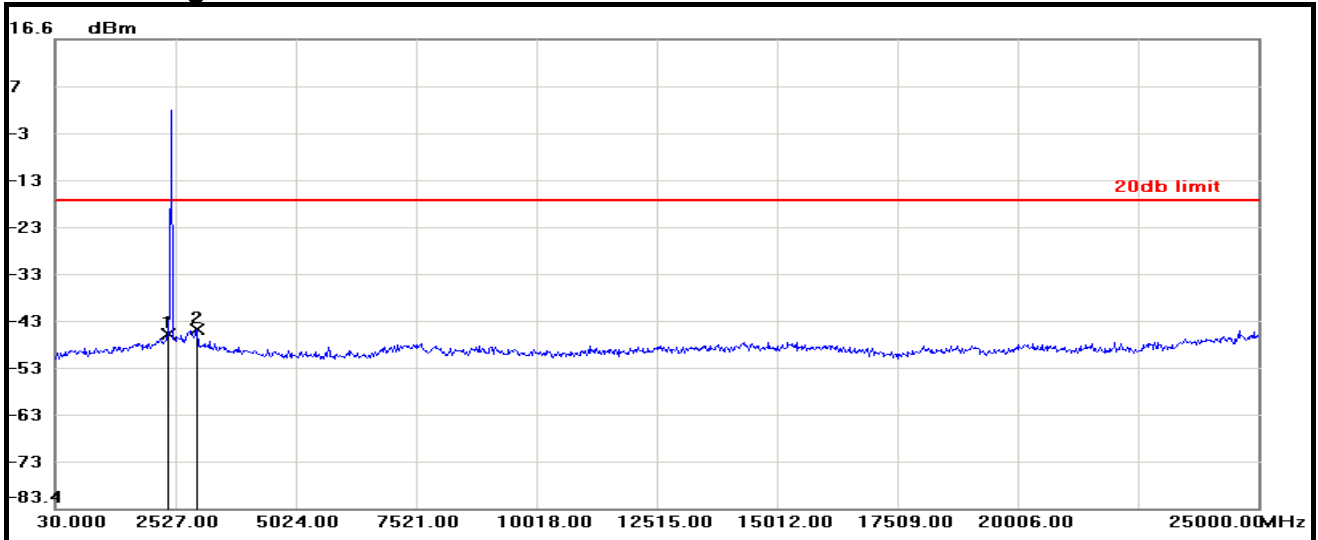

No.	Frequency(MHz)	Result(dBm)	Limit(dBm)	Margin(dBm)
1	2377.1800	-46.26	-17.77	-28.49
2	2976.4600	-45.23	-17.77	-27.46



IEEE 802.11g Mode / CH High / 2.38GHz ~ 2.5GHz

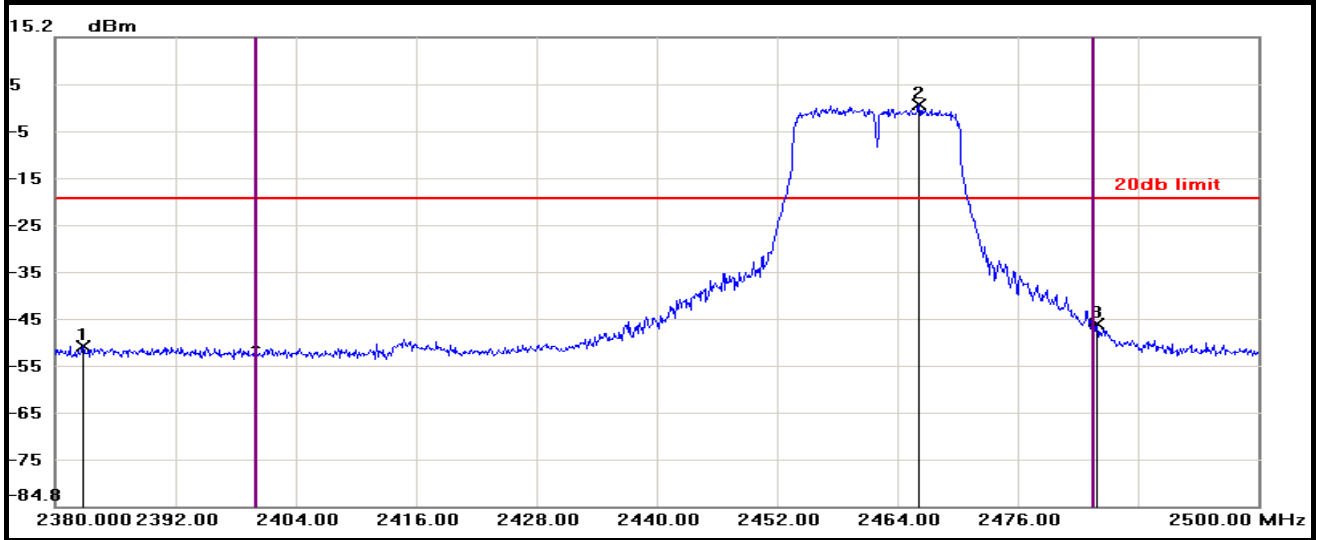

No.	Frequency(MHz)	Result(dBm)	Limit(dBm)	Margin(dBm)
1	2382.7600	-50.75	-19.28	-31.47
2	2466.1600	0.72	-19.28	20.00
3	2483.9200	-45.95	-19.28	-26.67

IEEE 802.11g Mode / CH High / Full band

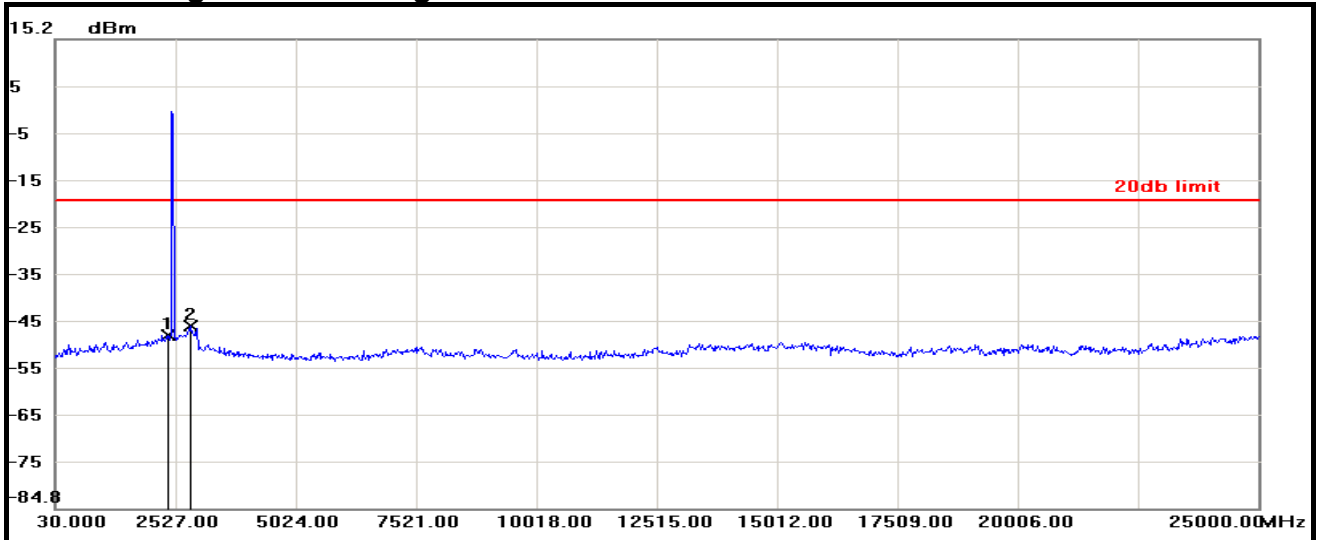

No.	Frequency(MHz)	Result(dBm)	Limit(dBm)	Margin(dBm)
1	2377.1800	-47.88	-19.28	-28.60
2	2826.6400	-46.03	-19.28	-26.75



7.5 RADIATED EMISSION

LIMITS

(1) According to § 15.205 (a) Except as shown in paragraph (d) of this section, only spurious emissions are permitted in any of the frequency bands listed below:

MHz	MHz	MHz	GHz
0.090 - 0.110	16.42 - 16.423	399.9 - 410	4.5 - 5.15
¹ 0.495 - 0.505	16.69475 - 16.69525	608 - 614	5.35 - 5.46
2.1735 - 2.1905	16.80425 - 16.80475	960 - 1240	7.25 - 7.75
4.125 - 4.128	25.5 - 25.67	1300 - 1427	8.025 - 8.5
4.17725 - 4.17775	37.5 - 38.25	1435 - 1626.5	9.0 - 9.2
4.20725 - 4.20775	73 - 74.6	1645.5 - 1646.5	9.3 - 9.5
6.215 - 6.218	74.8 - 75.2	1660 -1710	10.6 -12.7
6.26775 - 6.26825	108 -121.94	1718.8 - 1722.2	13.25 -13.4
6.31175 - 6.31225	123 - 138	2200 - 2300	14.47 – 14.5
8.291 - 8.294	149.9 - 150.05	2310 - 2390	15.35 -16.2
8.362 - 8.366	156.52475 - 156.52525	2483.5 - 2500	17.7 - 21.4
8.37625 - 8.38675	156.7 - 156.9	2655 - 2900	22.01 - 23.12
8.41425 - 8.41475	162.0125 - 167.17	3260 - 3267	23.6 - 24.0
12.29 - 12.293	167.72 - 173.2	3332 - 3339	31.2 - 31.8
12.51975 - 12.52025	240 - 285	3345.8 - 3338	36.43 - 36.5
12.57675 - 12.57725	322 -335.4	3600 - 4400	(²)
13.36 - 13.41			

Remark:

1. ¹ Until February 1, 1999, this restricted band shall be 0.490-0.510 MHz.
2. ² Above 38.6

(2) According to § 15.205 (b) Except as provided in paragraphs (d) and (e), the field strength of emissions appearing within these frequency bands shall not exceed the limits shown in Section 15.209. At frequencies equal to or less than 1000 MHz, compliance with the limits in Section 15.209 shall be demonstrated using measurement instrumentation employing a CISPR quasi-peak detector. Above 1000 MHz, compliance with the emission limits in Section 15.209 shall be demonstrated based on the average value of the measured emissions. The provisions in Section 15.35 apply to these measurements.



(3) According to § 15.209 (a) Except as provided elsewhere in this Subpart, the emissions from an intentional radiator shall not exceed the field strength levels specified in the following table :

Frequency (MHz)	Field Strength (microvolts/meter)	Measurement Distance (meters)
0.009 – 0.490	2400/F(KHz)	300
0.490 – 1.705	24000/F(KHz)	30
1.705 – 30.0	30	30
30 - 88	100 **	3
88 - 216	150 **	3
216 - 960	200 **	3
Above 960	500	3

Remark: **Except as provided in paragraph (g), fundamental emissions from intentional radiators operating under this Section shall not be located in the frequency bands 54-72 MHz, 76-88 MHz, 174-216 MHz or 470-806 MHz. However, operation within these frequency bands is permitted under other sections of this Part, e.g., Sections 15.231 and 15.241.

(4) According to § 15.209 (b) In the emission table above, the tighter limit applies at the band edges.

TEST EQUIPMENT

Radiated Emission / 966Chamber

Name of Equipment	Manufacture	Model	Serial Number	Calibration Due
Spectrum Analyzer	Agilent	E4446A	US42510252	11/02/2012
EMI Test Receiver	R&S	ESCI	100064	02/16/2013
Pre-Amplifier	Mini-Circults	ZFL-1000LN	SF350700823	01/12/2013
Pre-Amplifier	MITEQ	AFS44-00102650 -42-10P-44	1415367	11/19/2012
Bilog Antenna	Sunol Sciences	JB3	A030105	10/02/2013
Horn Antenna	EMCO	3117	00055165	01/11/2013
Horn Antenna	EMCO	3116	00026370	10/11/2013
Loop Antenna	EMCO	6502	8905/2356	06/10/2013
Turn Table	CCS	CC-T-1F	N/A	N.C.R
Antenna Tower	CCS	CC-A-1F	N/A	N.C.R
Controller	CCS	CC-C-1F	N/A	N.C.R
Site NSA	CCS	N/A	N/A	12/25/2012
Test S/W	EZ-EMC (CCS-3A1RE)			

Remark: 1. Each piece of equipment is scheduled for calibration once a year.
2. N.C.R = No Calibration Request.



TEST SETUP

The diagram below shows the test setup that is utilized to make the measurements for emission from below 1GHz.

9kHz ~ 30MHz

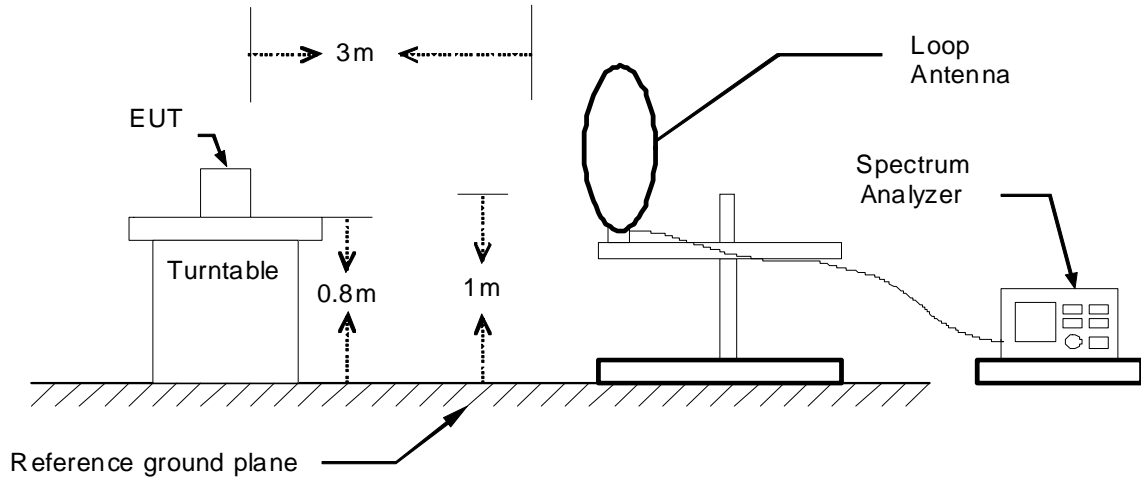

30MHz ~ 1GHz

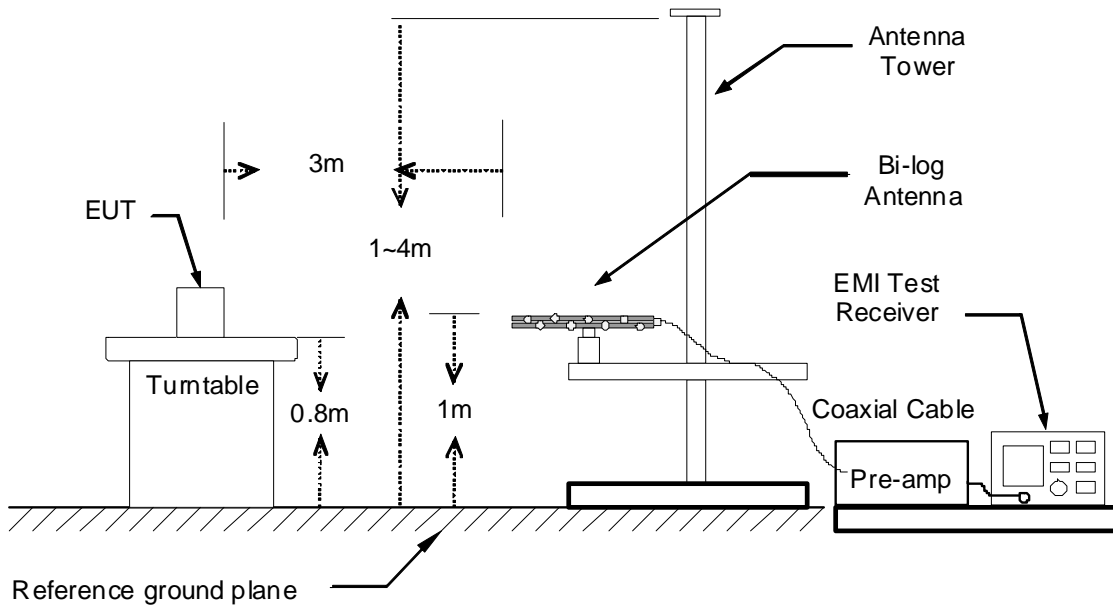



The diagram below shows the test setup that is utilized to make the measurements for emission above 1GHz.

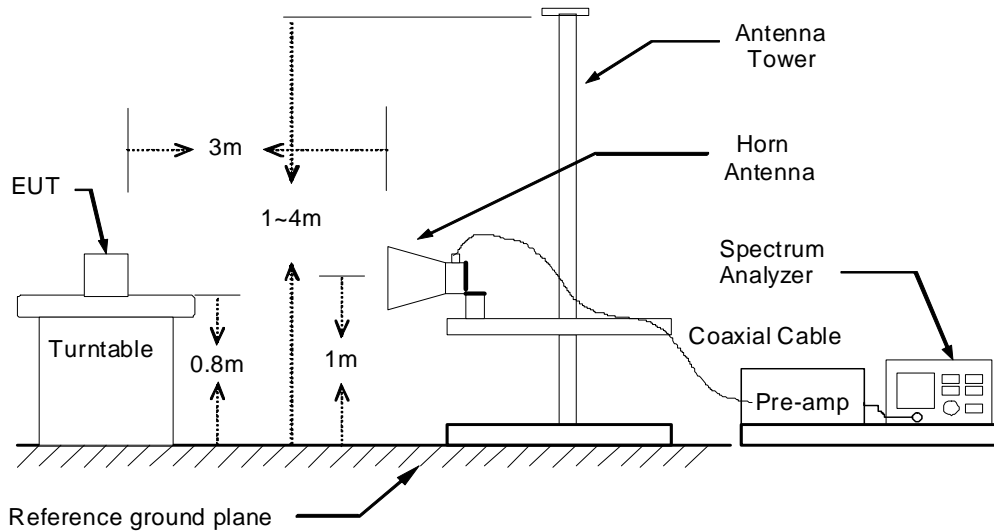

TEST PROCEDURE

1. The EUT was placed on the top of a rotating table 0.8 meters above the ground. The table was rotated 360 degrees to determine the position of the highest radiation.
2. While measuring the radiated emission below 1GHz, the EUT was set 3 meters away from the interference-receiving antenna, which was mounted on the top of a variable-height antenna tower. While measuring the radiated emission above 1GHz, the EUT was set 3 meters away from the interference-receiving antenna.
3. The antenna is a broadband antenna, and its height is varied from one meter to four meters above the ground to determine the maximum value of the field strength. Both horizontal and vertical polarization of the antenna are set to make the measurement.
4. For each suspected emission, the EUT was arranged to its worst case and then the antenna was tuned to heights from 1 meter to 4 meters and the table was turned from 0 degrees to 360 degrees to find the maximum reading.
5. The test-receiver system was set to Peak Detect Function and Specified Bandwidth with Maximum Hold Mode.
6. If the emission level of the EUT in peak mode was 10 dB lower than the limit specified, then testing could be stopped and the peak values of the EUT would be reported. Otherwise the emissions that did not have 10 dB margin would be re-tested one by one using peak, quasi-peak or average method as specified and then reported in a data sheet.

Remark :

1. The resolution bandwidth and video bandwidth of test receiver/spectrum analyzer is 120 KHz for Peak detection (PK) and Quasi-peak detection (QP) at frequency below 1GHz.
2. The resolution bandwidth and video bandwidth of test receiver/spectrum analyzer is 1 MHz for Peak detection and frequency above 1GHz.
3. The resolution bandwidth of test receiver/spectrum analyzer is 1 MHz and the video bandwidth is 10 Hz for Average detection (AV) at frequency above 1GHz.



TEST RESULTS

Below 1 GHz (9kHz ~ 30MHz)

No emission found between lowest internal used/generated frequency to 30MHz.

Below 1 GHz (30MHz ~ 1GHz)

Product Name	TireHawk TPMS Kit	Test By	Waternil Guan
Test Model	TB-X04C	Test Date	2012/10/20
Test Mode	Normal Operating (Not telescopic USB cable)	Temp. & Humidity	25°C, 56%

966 Chamber at 3Meter / Horizontal						
Frequency (MHz)	Reading (dBµV)	Correction Factor (dB/m)	Result (dBµV/m)	Limit (dBµV/m)	Margin (dB)	Remark
239.52	44.14	-13.63	30.50	46.00	-15.50	Peak
256.01	43.03	-13.03	30.00	46.00	-16.00	Peak
282.20	48.49	-11.57	36.92	46.00	-9.08	Peak
359.80	38.07	-10.29	27.79	46.00	-18.21	Peak
384.05	39.06	-9.85	29.21	46.00	-16.79	Peak
760.41	34.77	-3.71	31.06	46.00	-14.94	Peak
839.95	34.76	-2.42	32.34	46.00	-13.66	Peak
960.23	37.59	-0.75	36.84	54.00	-17.16	Peak

966 Chamber at 3Meter / Vertical						
Frequency (MHz)	Reading (dBµV)	Correction Factor (dB/m)	Result (dBµV/m)	Limit (dBµV/m)	Margin (dB)	Remark
39.70	45.64	-12.63	33.01	40.00	-6.99	Peak
120.21	41.15	-13.30	27.86	43.50	-15.64	Peak
188.11	39.25	-14.08	25.17	43.50	-18.33	Peak
239.52	43.42	-13.63	29.79	46.00	-16.21	Peak
256.01	39.88	-13.03	26.85	46.00	-19.15	Peak
282.20	42.36	-11.57	30.79	46.00	-15.21	Peak
467.47	46.68	-8.36	38.32	46.00	-7.68	Peak
868.08	41.78	-1.99	39.80	46.00	-6.20	Peak

Remark:

1. Quasi-peak test would be performed if the peak result were greater than the quasi-peak limit.
2. Data of measurement within this frequency range shown " --- " in the table above means the reading of emissions are attenuated more than 20dB below the permissible limits or the field strength is too small to be measured.
3. Correction Factor (dB/m) = Antenna Factor (dB/m) + Cable Loss (dB) – PreAmp.Gain (dB)
4. Result (dBµV/m) = Reading (dBµV) + Correction Factor (dB/m)
5. Margin (dB) = Remark result (dBµV/m) - Quasi-peak limit (dBµV/m).



Above 1 GHz

Product Name	TireHawk TPMS Kit	Test By	Waternil Guan
Test Model	TB-X04C	Test Date	2012/10/20
Test Mode	IEEE 802.11b TX / CH Low	Temp. & Humidity	25°C, 56%

966 Chamber at 3Meter / Horizontal									
Frequency (MHz)	Reading-PK (dBuV)	Reading-AV (dBuV)	Correction Factor (dB/m)	Result-PK (dBuV/m)	Result-AV (dBuV/m)	Limit-PK (dBuV/m)	Limit-AV (dBuV/m)	Margin (dB)	Remark
1602.00	48.42	---	-1.33	47.09	---	74.00	54.00	-6.91	Peak
1796.00	43.78	---	0.41	44.19	---	74.00	54.00	-9.81	Peak
2750.00	43.07	---	4.47	47.54	---	74.00	54.00	-6.46	Peak
3780.00	41.02	---	6.67	47.69	---	74.00	54.00	-6.31	Peak
4530.00	40.41	---	8.45	48.86	---	74.00	54.00	-5.14	Peak
4995.00	39.87	---	9.68	49.55	---	74.00	54.00	-4.45	Peak

966 Chamber at 3Meter / Vertical									
Frequency (MHz)	Reading-PK (dBuV)	Reading-AV (dBuV)	Correction Factor (dB/m)	Result-PK (dBuV/m)	Result-AV (dBuV/m)	Limit-PK (dBuV/m)	Limit-AV (dBuV/m)	Margin (dB)	Remark
1478.00	47.51	---	-2.33	45.18	---	74.00	54.00	-8.82	Peak
1604.00	48.48	---	-1.31	47.16	---	74.00	54.00	-6.84	Peak
2664.00	46.42	---	4.29	50.72	---	74.00	54.00	-3.28	Peak
3360.00	41.63	---	5.73	47.37	---	74.00	54.00	-6.63	Peak
4485.00	40.38	---	8.33	48.71	---	74.00	54.00	-5.29	Peak
4935.00	40.45	---	9.52	49.97	---	74.00	54.00	-4.03	Peak

Remark:

1. Measuring frequencies from 1 GHz to the 10th harmonic of highest fundamental frequency.
2. Average test would be performed if the peak result were greater than the average limit.
3. Data of measurement within this frequency range shown " --- " in the table above means the reading of emissions are attenuated more than 20dB below the permissible limits or the field strength is too small to be measured.
4. Measurements above show only up to 6 maximum emissions noted, or would be lesser, with " N/A " remark, if no specific emissions from the EUT are recorded (ie: margin>20dB from the applicable limit) and considered that's already beyond the background noise floor.
5. Result = Reading + Correction Factor
 Margin = Result - Limit
 Remark Peak = Result(PK) - Limit(AV)
 Remark AVG = Result(AV) - Limit(AV)



Product Name	TireHawk TPMS Kit	Test By	Waternil Guan
Test Model	TB-X04C	Test Date	2012/10/20
Test Mode	IEEE 802.11b TX / CH Middle	Temp. & Humidity	25°C, 56%

966 Chamber at 3Meter / Horizontal

Frequency (MHz)	Reading-PK (dBuV)	Reading-AV (dBuV)	Correction Factor (dB/m)	Result-PK (dBuV/m)	Result-AV (dBuV/m)	Limit-PK (dBuV/m)	Limit-AV (dBuV/m)	Margin (dB)	Remark
1602.00	48.56	---	-1.33	47.23	---	74.00	54.00	-6.77	Peak
2032.00	44.47	---	2.36	46.83	---	74.00	54.00	-7.17	Peak
2728.00	43.76	---	4.43	48.19	---	74.00	54.00	-5.81	Peak
3615.00	41.23	---	6.29	47.52	---	74.00	54.00	-6.48	Peak
4395.00	40.30	---	8.12	48.42	---	74.00	54.00	-5.58	Peak
4875.00	39.71	---	9.36	49.07	---	74.00	54.00	-4.93	Peak

966 Chamber at 3Meter / Vertical

Frequency (MHz)	Reading-PK (dBuV)	Reading-AV (dBuV)	Correction Factor (dB/m)	Result-PK (dBuV/m)	Result-AV (dBuV/m)	Limit-PK (dBuV/m)	Limit-AV (dBuV/m)	Margin (dB)	Remark
1598.00	49.66	---	-1.37	48.29	---	74.00	54.00	-5.71	Peak
2574.00	45.51	---	4.11	49.62	---	74.00	54.00	-4.38	Peak
2660.00	46.12	---	4.29	50.40	---	74.00	54.00	-3.60	Peak
3255.00	41.23	---	5.52	46.75	---	74.00	54.00	-7.25	Peak
4380.00	40.22	---	8.08	48.30	---	74.00	54.00	-5.70	Peak
4965.00	39.19	---	9.60	48.79	---	74.00	54.00	-5.21	Peak

Remark:

1. Measuring frequencies from 1 GHz to the 10th harmonic of highest fundamental frequency.
2. Average test would be performed if the peak result were greater than the average limit.
3. Data of measurement within this frequency range shown " --- " in the table above means the reading of emissions are attenuated more than 20dB below the permissible limits or the field strength is too small to be measured.
4. Measurements above show only up to 6 maximum emissions noted, or would be lesser, with " N/A " remark, if no specific emissions from the EUT are recorded (ie: margin>20dB from the applicable limit) and considered that's already beyond the background noise floor.
5. Result = Reading + Correction Factor
Margin = Result - Limit
Remark Peak = Result(PK) - Limit(AV)
Remark AVG = Result(AV) - Limit(AV)



Product Name	TireHawk TPMS Kit	Test By	Waternil Guan
Test Model	TB-X04C	Test Date	2012/10/20
Test Mode	IEEE 802.11b TX / CH High	Temp. & Humidity	25°C, 56%

966 Chamber at 3Meter / Horizontal

Frequency (MHz)	Reading-PK (dBuV)	Reading-AV (dBuV)	Correction Factor (dB/m)	Result-PK (dBuV/m)	Result-AV (dBuV/m)	Limit-PK (dBuV/m)	Limit-AV (dBuV/m)	Margin (dB)	Remark
1604.00	47.98	---	-1.31	46.66	---	74.00	54.00	-7.34	Peak
2000.00	44.85	---	2.25	47.10	---	74.00	54.00	-6.90	Peak
2682.00	43.46	---	4.33	47.80	---	74.00	54.00	-6.20	Peak
3375.00	41.68	---	5.76	47.44	---	74.00	54.00	-6.56	Peak
4605.00	40.41	---	8.65	49.06	---	74.00	54.00	-4.94	Peak
5070.00	40.67	---	9.79	50.46	---	74.00	54.00	-3.54	Peak

966 Chamber at 3Meter / Vertical

Frequency (MHz)	Reading-PK (dBuV)	Reading-AV (dBuV)	Correction Factor (dB/m)	Result-PK (dBuV/m)	Result-AV (dBuV/m)	Limit-PK (dBuV/m)	Limit-AV (dBuV/m)	Margin (dB)	Remark
1498.00	46.55	---	-2.26	44.30	---	74.00	54.00	-9.70	Peak
1600.00	49.99	---	-1.35	48.64	---	74.00	54.00	-5.36	Peak
2666.00	47.78	---	4.30	52.08	---	74.00	54.00	-1.92	Peak
4260.00	39.55	---	7.80	47.35	---	74.00	54.00	-6.65	Peak
4650.00	39.46	---	8.77	48.23	---	74.00	54.00	-5.77	Peak
4980.00	39.11	---	9.64	48.75	---	74.00	54.00	-5.25	Peak

Remark:

1. Measuring frequencies from 1 GHz to the 10th harmonic of highest fundamental frequency.
2. Average test would be performed if the peak result were greater than the average limit.
3. Data of measurement within this frequency range shown " --- " in the table above means the reading of emissions are attenuated more than 20dB below the permissible limits or the field strength is too small to be measured.
4. Measurements above show only up to 6 maximum emissions noted, or would be lesser, with " N/A " remark, if no specific emissions from the EUT are recorded (ie: margin>20dB from the applicable limit) and considered that's already beyond the background noise floor.
5. Result = Reading + Correction Factor
Margin = Result - Limit
Remark Peak = Result(PK) - Limit(AV)
Remark AVG = Result(AV) - Limit(AV)



Product Name	TireHawk TPMS Kit	Test By	Waternil Guan
Test Model	TB-X04C	Test Date	2012/10/20
Test Mode	IEEE 802.11g TX / CH Low	Temp. & Humidity	25°C, 56%

966 Chamber at 3Meter / Horizontal

Frequency (MHz)	Reading-PK (dBuV)	Reading-AV (dBuV)	Correction Factor (dB/m)	Result-PK (dBuV/m)	Result-AV (dBuV/m)	Limit-PK (dBuV/m)	Limit-AV (dBuV/m)	Margin (dB)	Remark
1600.00	49.09	---	-1.35	47.74	---	74.00	54.00	-6.26	Peak
1984.00	44.53	---	2.11	46.64	---	74.00	54.00	-7.36	Peak
2894.00	42.65	---	4.78	47.43	---	74.00	54.00	-6.57	Peak
3420.00	41.15	---	5.86	47.01	---	74.00	54.00	-6.99	Peak
4140.00	40.99	---	7.51	48.51	---	74.00	54.00	-5.49	Peak
4920.00	39.19	---	9.48	48.66	---	74.00	54.00	-5.34	Peak

966 Chamber at 3Meter / Vertical

Frequency (MHz)	Reading-PK (dBuV)	Reading-AV (dBuV)	Correction Factor (dB/m)	Result-PK (dBuV/m)	Result-AV (dBuV/m)	Limit-PK (dBuV/m)	Limit-AV (dBuV/m)	Margin (dB)	Remark
1470.00	47.31	---	-2.36	44.96	---	74.00	54.00	-9.04	Peak
1596.00	51.20	---	-1.39	49.81	---	74.00	54.00	-4.19	Peak
2668.00	46.79	---	4.30	51.09	---	74.00	54.00	-2.91	Peak
3450.00	41.62	---	5.92	47.53	---	74.00	54.00	-6.47	Peak
4245.00	39.71	---	7.76	47.47	---	74.00	54.00	-6.53	Peak
4950.00	40.44	---	9.56	50.00	---	74.00	54.00	-4.00	Peak

Remark:

1. Measuring frequencies from 1 GHz to the 10th harmonic of highest fundamental frequency.
2. Average test would be performed if the peak result were greater than the average limit.
3. Data of measurement within this frequency range shown " --- " in the table above means the reading of emissions are attenuated more than 20dB below the permissible limits or the field strength is too small to be measured.
4. Measurements above show only up to 6 maximum emissions noted, or would be lesser, with " N/A " remark, if no specific emissions from the EUT are recorded (ie: margin>20dB from the applicable limit) and considered that's already beyond the background noise floor.
5. Result = Reading + Correction Factor
Margin = Result - Limit
Remark Peak = Result(PK) - Limit(AV)
Remark AVG = Result(AV) - Limit(AV)



Product Name	TireHawk TPMS Kit	Test By	Waternil Guan
Test Model	TB-X04C	Test Date	2012/10/20
Test Mode	IEEE 802.11g TX / CH Middle	Temp. & Humidity	25°C, 56%

966 Chamber at 3Meter / Horizontal

Frequency (MHz)	Reading-PK (dBuV)	Reading-AV (dBuV)	Correction Factor (dB/m)	Result-PK (dBuV/m)	Result-AV (dBuV/m)	Limit-PK (dBuV/m)	Limit-AV (dBuV/m)	Margin (dB)	Remark
1604.00	48.90	---	-1.31	47.59	---	74.00	54.00	-6.41	Peak
2204.00	46.46	---	2.94	49.41	---	74.00	54.00	-4.59	Peak
2948.00	43.22	---	4.89	48.11	---	74.00	54.00	-5.89	Peak
3120.00	41.37	---	5.24	46.62	---	74.00	54.00	-7.38	Peak
4470.00	39.62	---	8.30	47.92	---	74.00	54.00	-6.08	Peak
4980.00	39.13	---	9.64	48.76	---	74.00	54.00	-5.24	Peak

966 Chamber at 3Meter / Vertical

Frequency (MHz)	Reading-PK (dBuV)	Reading-AV (dBuV)	Correction Factor (dB/m)	Result-PK (dBuV/m)	Result-AV (dBuV/m)	Limit-PK (dBuV/m)	Limit-AV (dBuV/m)	Margin (dB)	Remark
1462.00	46.43	---	-2.38	44.05	---	74.00	54.00	-9.95	Peak
1602.00	49.83	---	-1.33	48.50	---	74.00	54.00	-5.50	Peak
2668.00	47.72	---	4.30	52.02	---	74.00	54.00	-1.98	Peak
3375.00	41.05	---	5.76	46.81	---	74.00	54.00	-7.19	Peak
3840.00	41.05	---	6.81	47.86	---	74.00	54.00	-6.14	Peak
5010.00	39.27	---	9.70	48.98	---	74.00	54.00	-5.02	Peak

Remark:

1. Measuring frequencies from 1 GHz to the 10th harmonic of highest fundamental frequency.
2. Average test would be performed if the peak result were greater than the average limit.
3. Data of measurement within this frequency range shown " --- " in the table above means the reading of emissions are attenuated more than 20dB below the permissible limits or the field strength is too small to be measured.
4. Measurements above show only up to 6 maximum emissions noted, or would be lesser, with " N/A " remark, if no specific emissions from the EUT are recorded (ie: margin>20dB from the applicable limit) and considered that's already beyond the background noise floor.
5. Result = Reading + Correction Factor
Margin = Result - Limit
Remark Peak = Result(PK) - Limit(AV)
Remark AVG = Result(AV) - Limit(AV)



Product Name	TireHawk TPMS Kit	Test By	Waternil Guan
Test Model	TB-X04C	Test Date	2012/10/20
Test Mode	IEEE 802.11g TX / CH High	Temp. & Humidity	25°C, 56%

966 Chamber at 3Meter / Horizontal									
Frequency (MHz)	Reading-PK (dBuV)	Reading-AV (dBuV)	Correction Factor (dB/m)	Result-PK (dBuV/m)	Result-AV (dBuV/m)	Limit-PK (dBuV/m)	Limit-AV (dBuV/m)	Margin (dB)	Remark
1498.00	45.69	---	-2.26	43.43	---	74.00	54.00	-10.57	Peak
1598.00	48.69	---	-1.37	47.32	---	74.00	54.00	-6.68	Peak
2012.00	44.09	---	2.29	46.38	---	74.00	54.00	-7.62	Peak
3390.00	40.84	---	5.80	46.64	---	74.00	54.00	-7.36	Peak
4230.00	39.70	---	7.73	47.42	---	74.00	54.00	-6.58	Peak
4920.00	39.58	---	9.48	49.06	---	74.00	54.00	-4.94	Peak
966 Chamber at 3Meter / Vertical									
Frequency (MHz)	Reading-PK (dBuV)	Reading-AV (dBuV)	Correction Factor (dB/m)	Result-PK (dBuV/m)	Result-AV (dBuV/m)	Limit-PK (dBuV/m)	Limit-AV (dBuV/m)	Margin (dB)	Remark
1334.00	46.39	---	-2.83	43.56	---	74.00	54.00	-10.44	Peak
1596.00	48.51	---	-1.39	47.12	---	74.00	54.00	-6.88	Peak
2672.00	46.89	---	4.31	51.20	---	74.00	54.00	-2.80	Peak
3540.00	40.94	---	6.11	47.05	---	74.00	54.00	-6.95	Peak
4020.00	40.13	---	7.23	47.36	---	74.00	54.00	-6.64	Peak
5010.00	39.16	---	9.70	48.87	---	74.00	54.00	-5.13	Peak

Remark:

1. Measuring frequencies from 1 GHz to the 10th harmonic of highest fundamental frequency.
2. Average test would be performed if the peak result were greater than the average limit.
3. Data of measurement within this frequency range shown " --- " in the table above means the reading of emissions are attenuated more than 20dB below the permissible limits or the field strength is too small to be measured.
4. Measurements above show only up to 6 maximum emissions noted, or would be lesser, with " N/A " remark, if no specific emissions from the EUT are recorded (ie: margin>20dB from the applicable limit) and considered that's already beyond the background noise floor.
5. Result = Reading + Correction Factor
Margin = Result - Limit
Remark Peak = Result(PK) - Limit(AV)
Remark AVG = Result(AV) - Limit(AV)



Restricted Band Edges

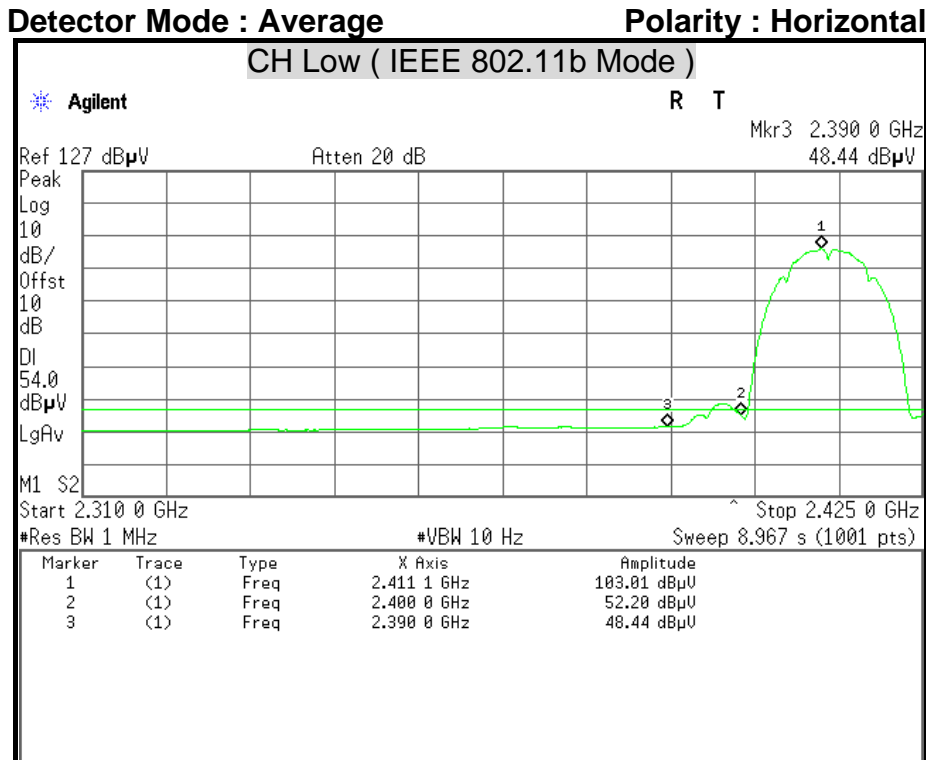
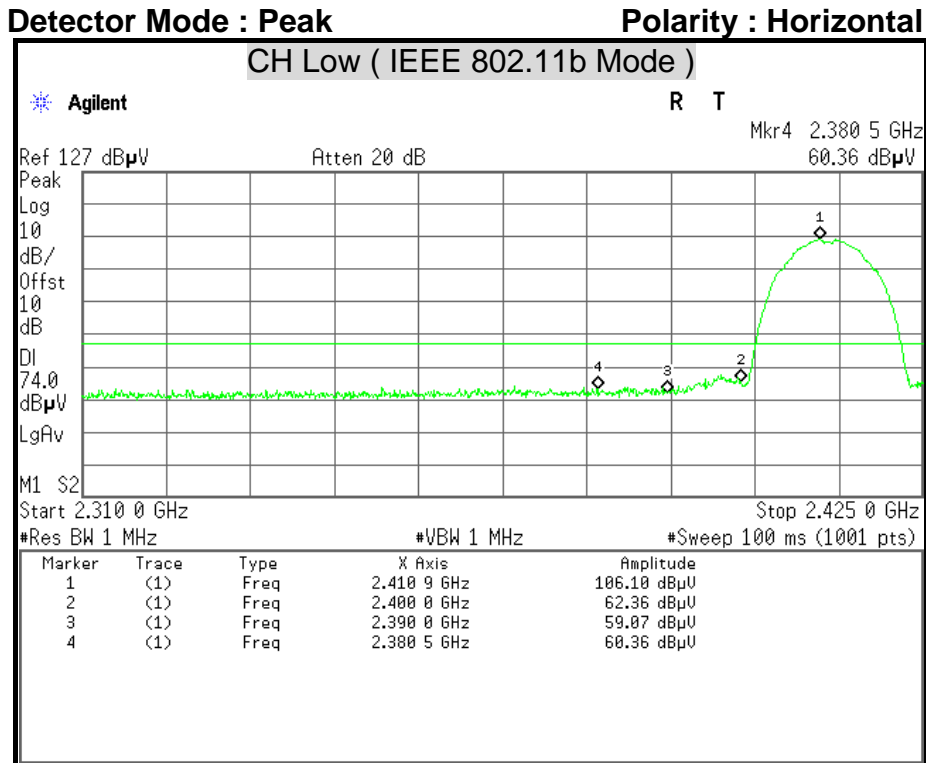



Detector Mode : Peak

Polarity : Vertical

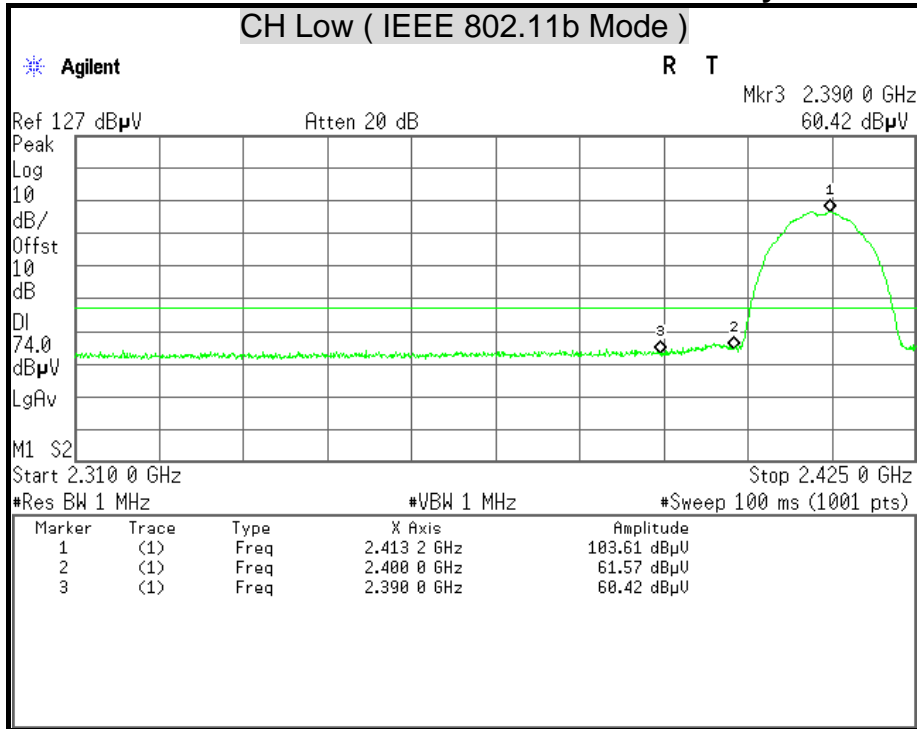

Detector Mode : Average

Polarity : Vertical

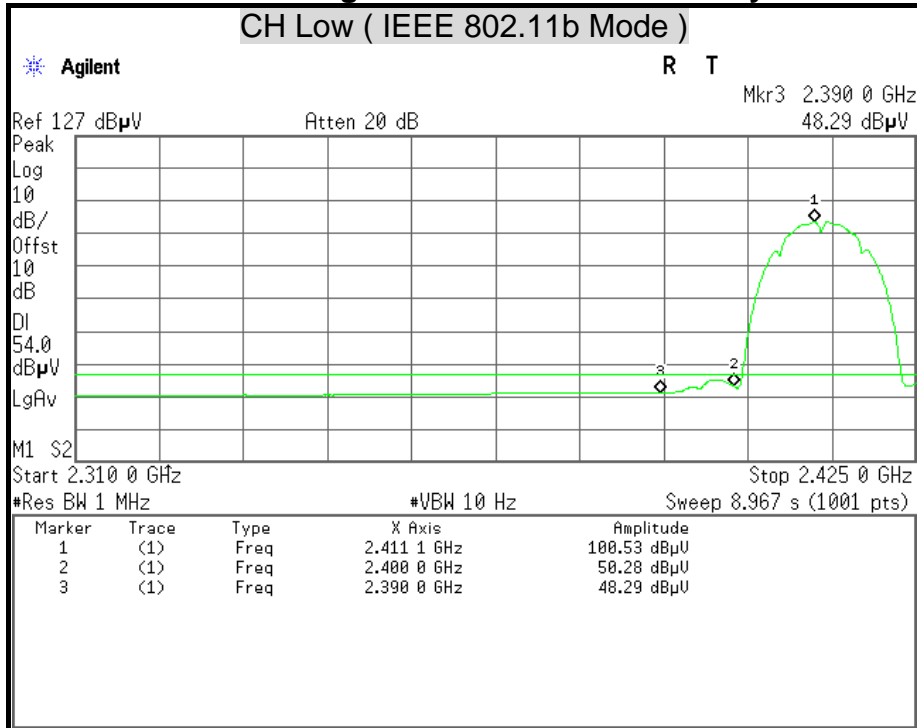



Detector Mode : Peak

Polarity : Horizontal

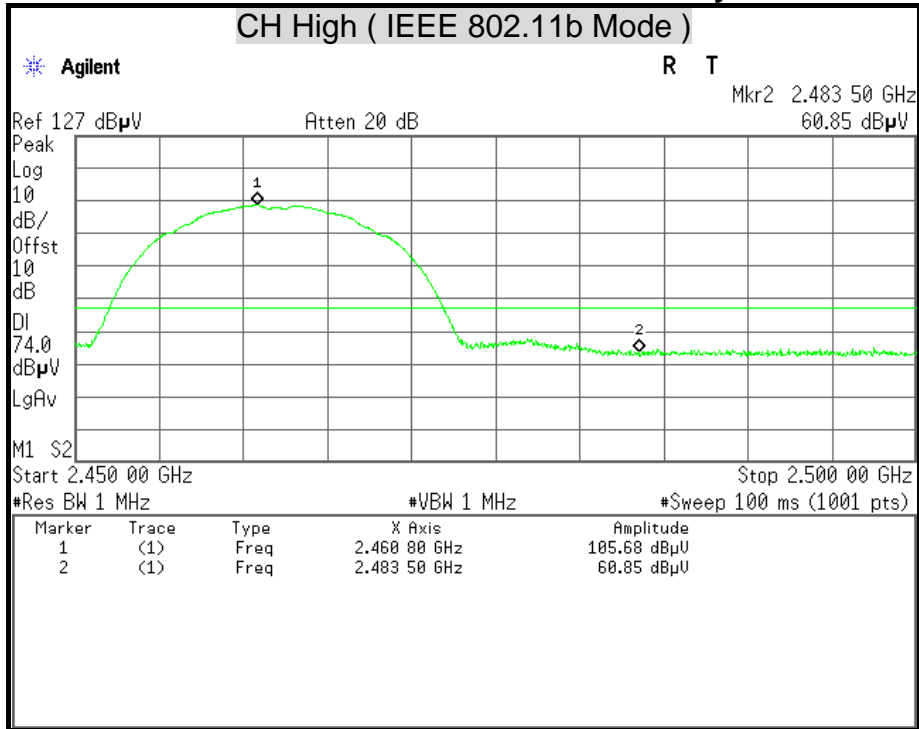

Detector Mode : Average

Polarity : Horizontal

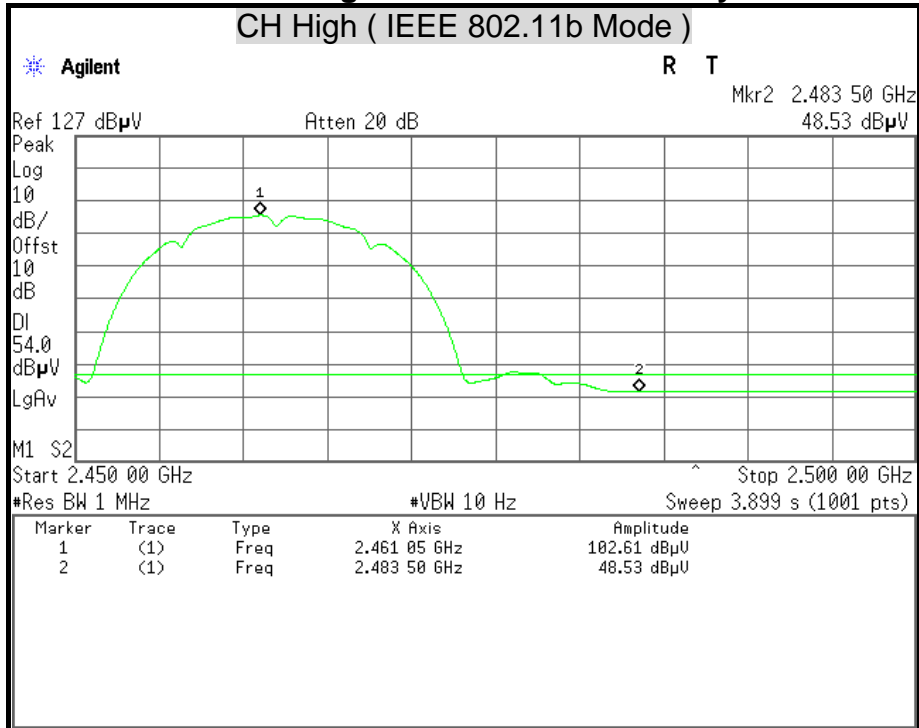



Detector Mode : Peak

Polarity : Vertical

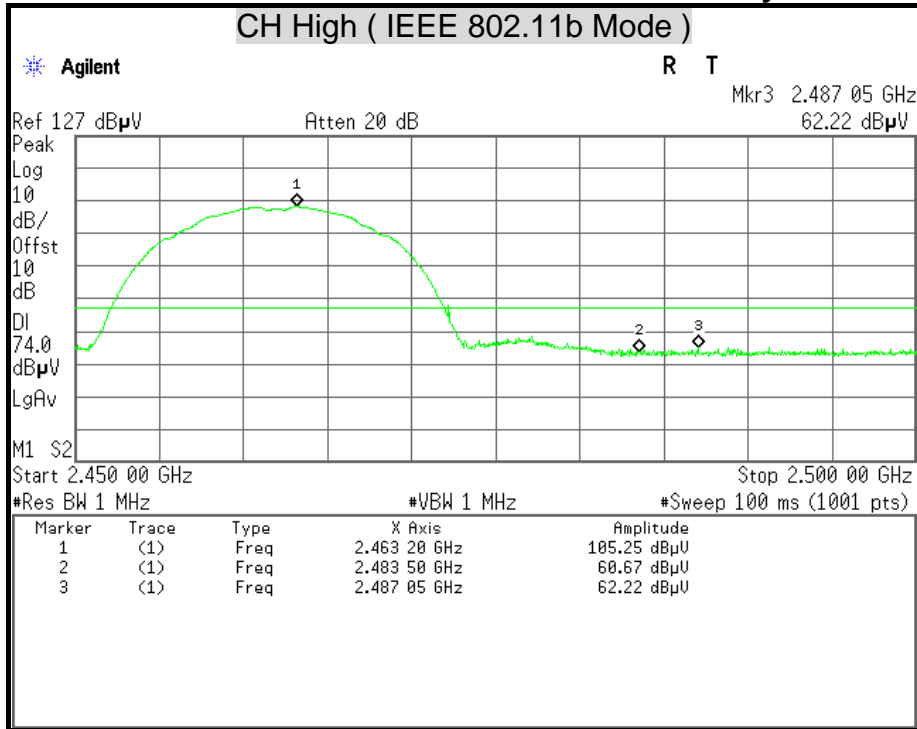

Detector Mode : Average

Polarity : Vertical

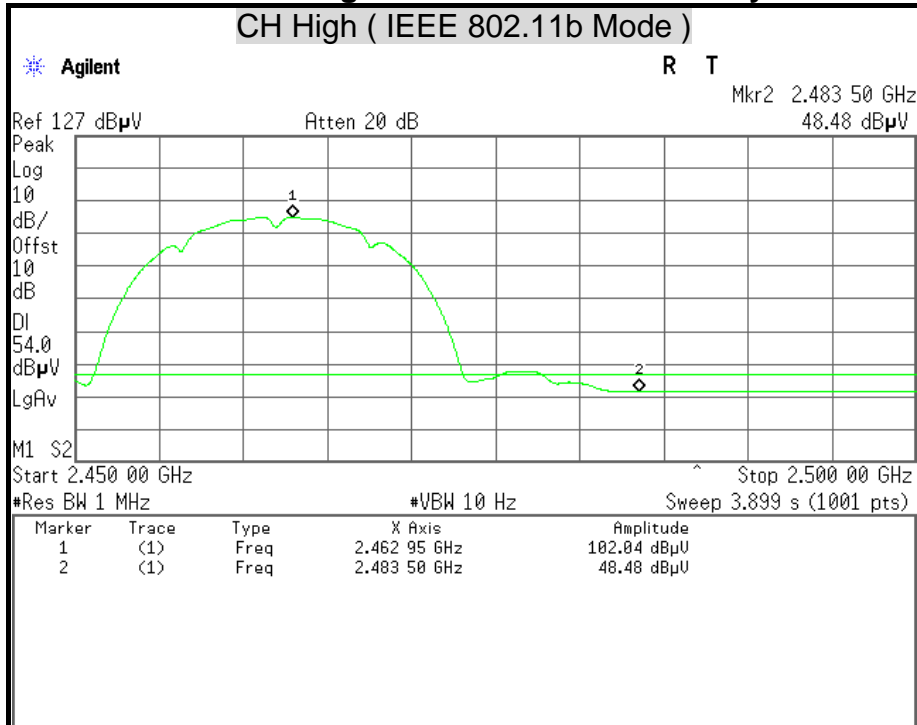



Detector Mode : Peak

Polarity : Horizontal

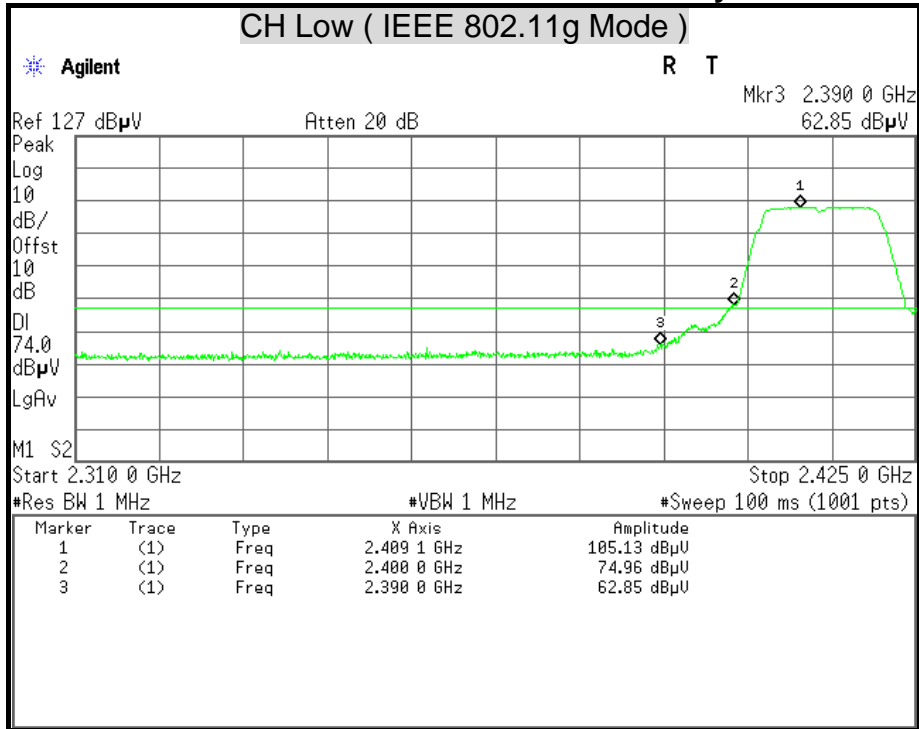

Detector Mode : Average

Polarity : Horizontal

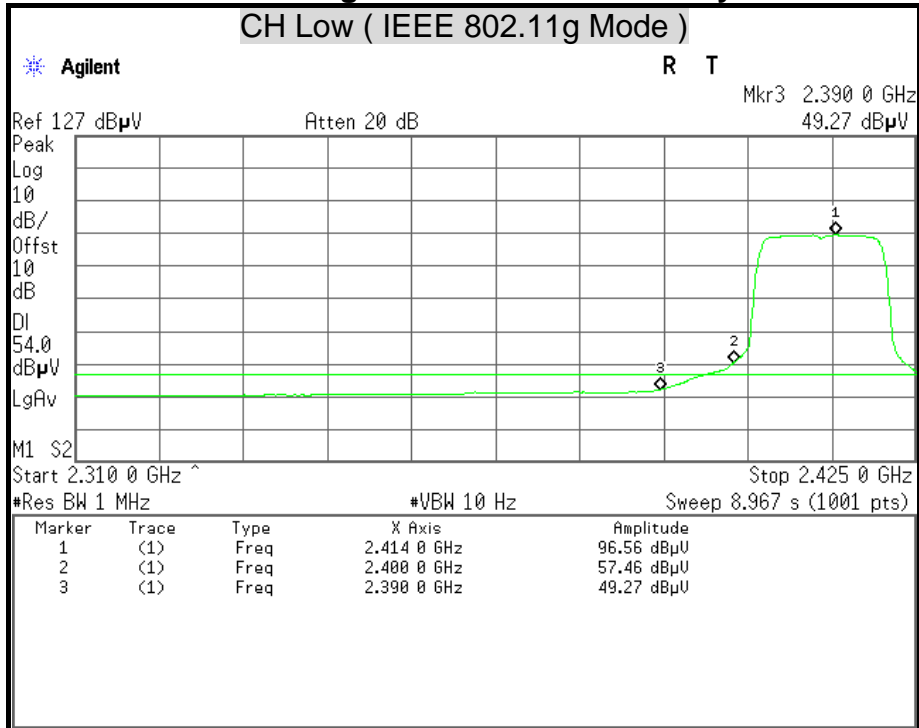



Detector Mode : Peak

Polarity : Vertical

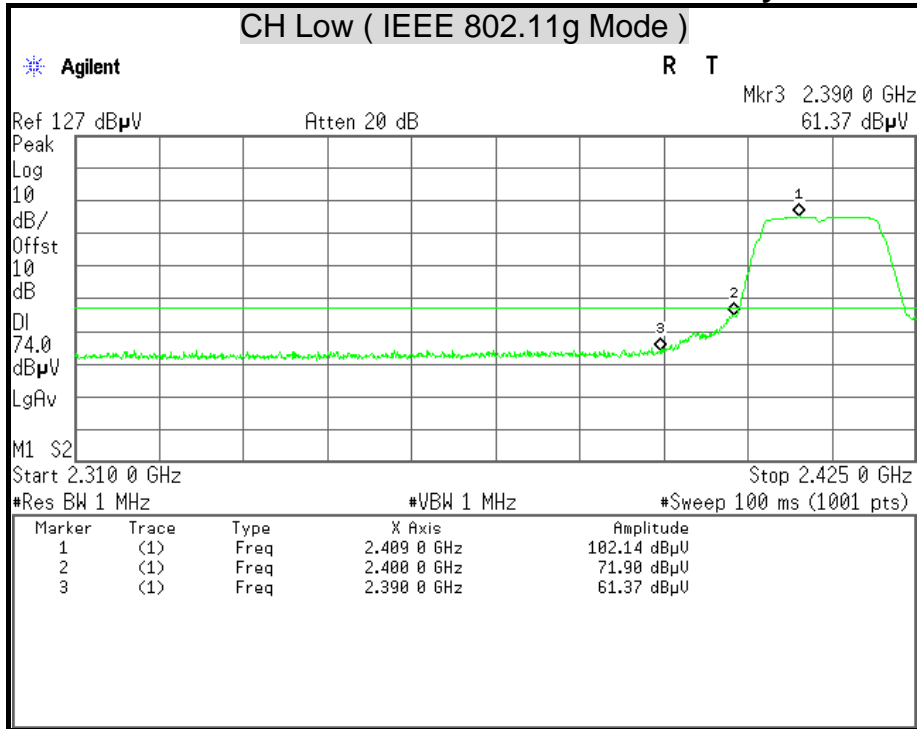

Detector Mode : Average

Polarity : Vertical

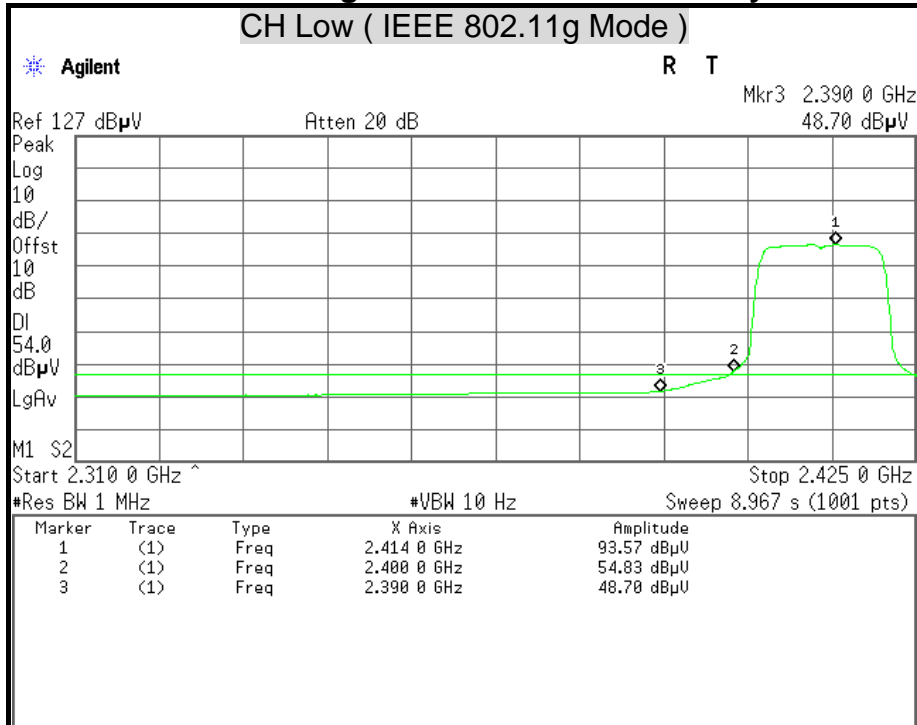



Detector Mode : Peak

Polarity : Horizontal

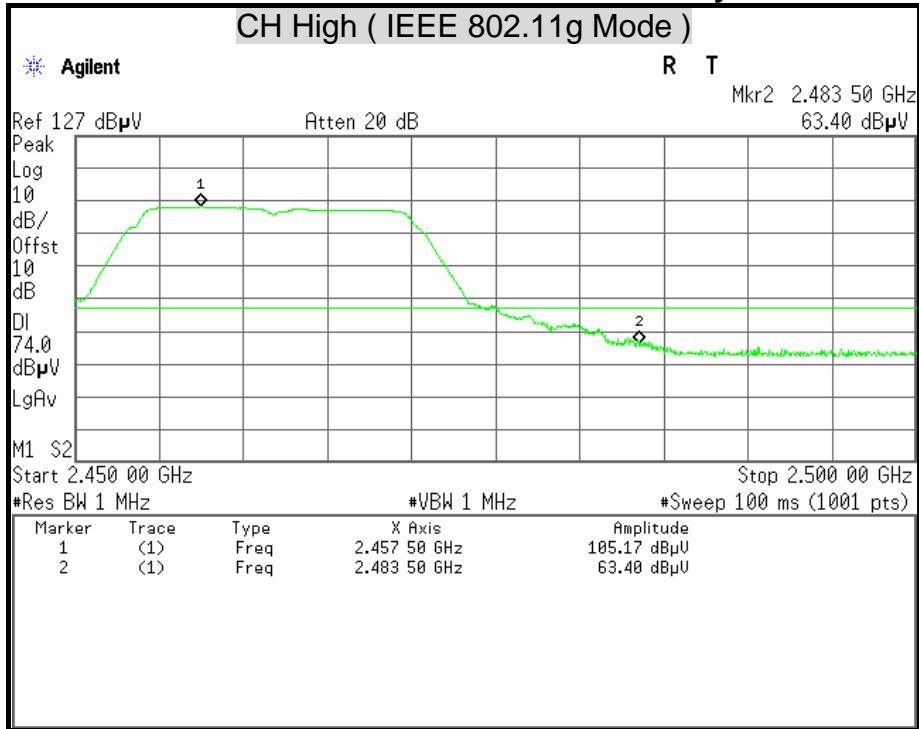

Detector Mode : Average

Polarity : Horizontal

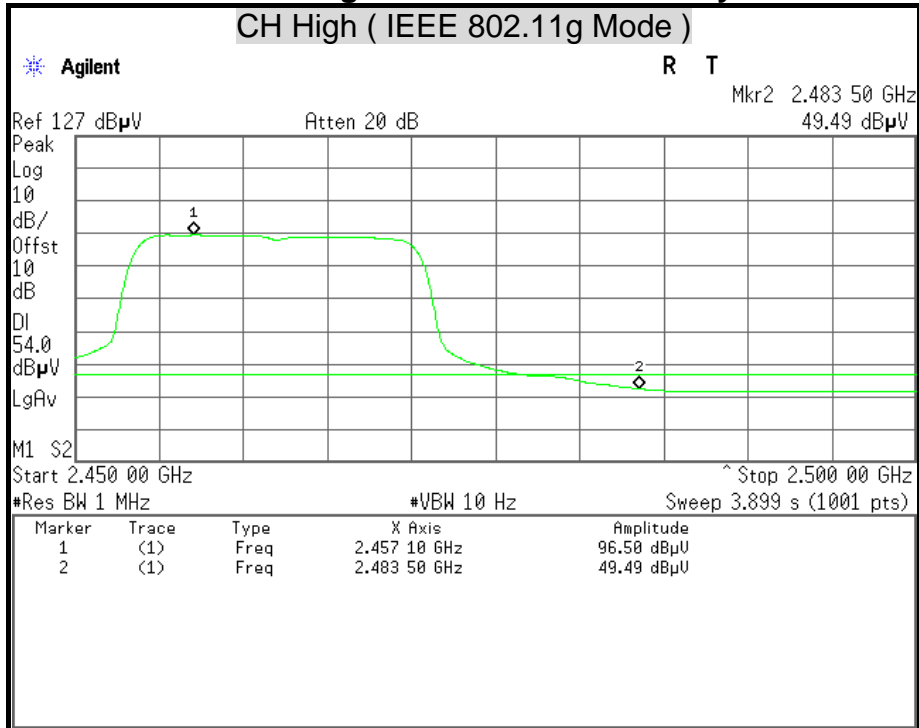



Detector Mode : Peak

Polarity : Vertical

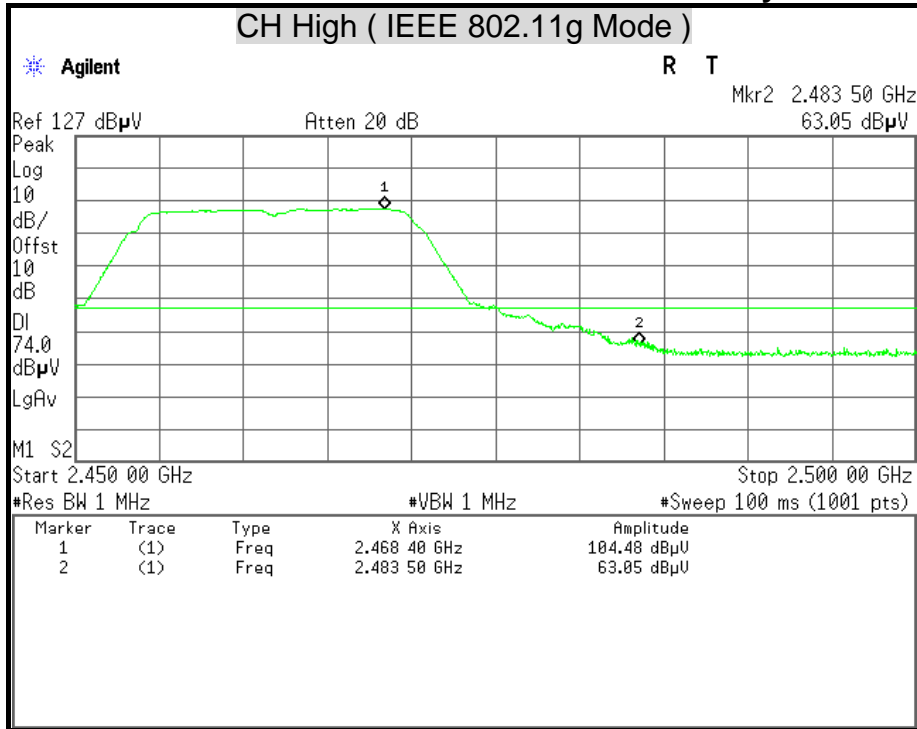

Detector Mode : Average

Polarity : Vertical

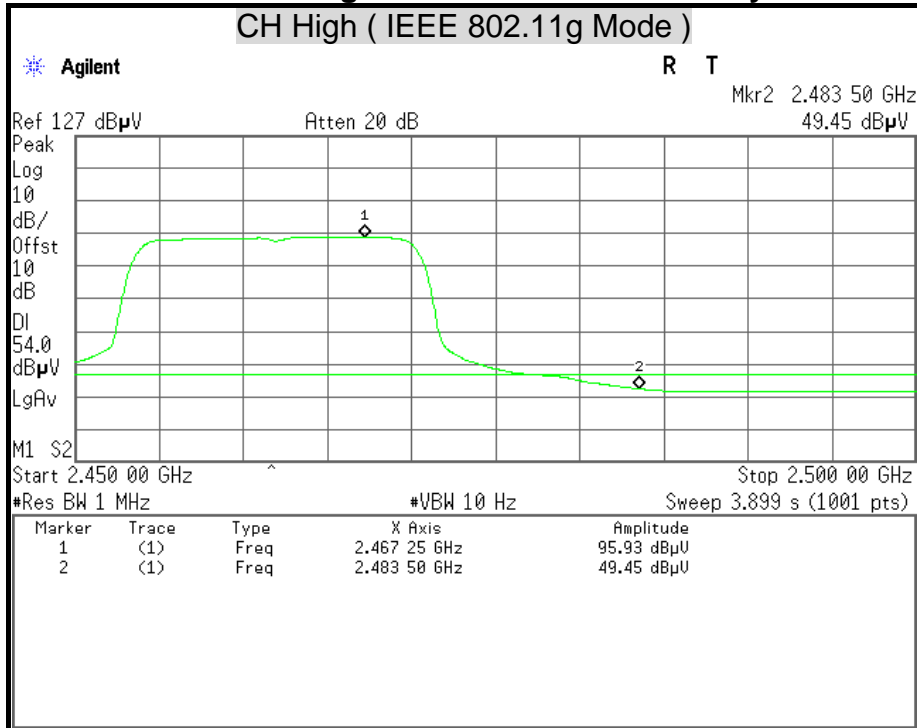



7.6 CONDUCTED EMISSION

LIMITS

§ 15.207 (a) Except as shown in paragraph (b) and (c) this section, for an intentional radiator that is designed to be connected to the public utility (AC) power line, the radio frequency voltage that is conducted back onto the AC power line on any frequency or frequencies within the band 150 kHz to 30 MHz shall not exceed the limits in the following table, as measured using a 50 μ H/50 ohms line impedance stabilization network (LISN). Compliance with the provisions of this paragraph shall be based on the measurement of the radio frequency voltage between each power line and ground at the power terminal. The lower limit applies at the boundary between the frequency ranges.

Frequency Range (MHz)	Conducted Limit (dB μ v)	
	Quasi-peak	Average
0.15 - 0.50	66 to 56	56 to 46
0.50 - 5.00	56	46
5.00 - 30.0	60	50

TEST EQUIPMENT

Name of Equipment	Manufacturer	Model	Serial Number	Calibration Due
EMI Test Receiver	R&S	ESCI	101073	07/31/2013
LISN	R&S	ENV216	101054	06/06/2013
LISN	EMCO	3825/2	9106-1809	07/03/2013
ISN	FCC	FCC-TLISN-T2-02-09	100105	07/30/2013
ISN	FCC	FCC-TLISN-T8-02-09	100106	07/31/2013
Capacitive Voltage Probe	FCC	F-CVP-1	100185	03/25/2013
Test S/W	CCS-3A1-CE			

Remark: Each piece of equipment is scheduled for calibration once a year.



TEST SETUP

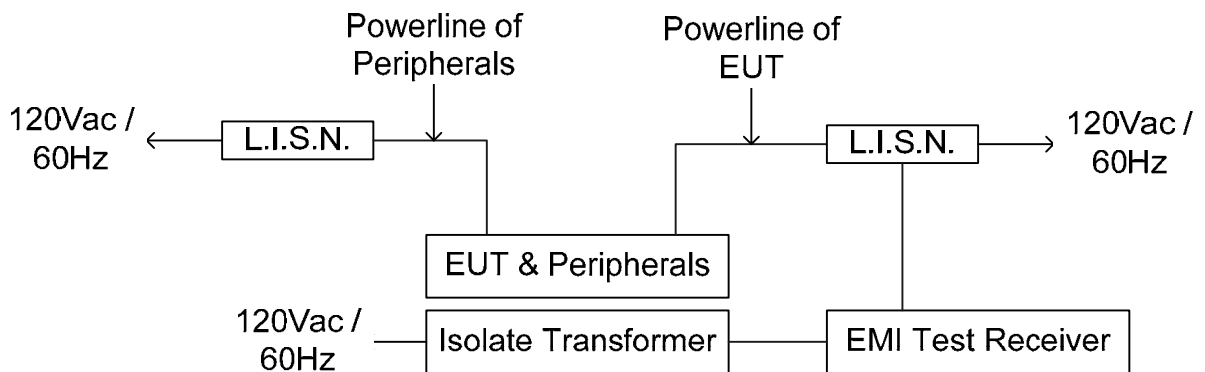
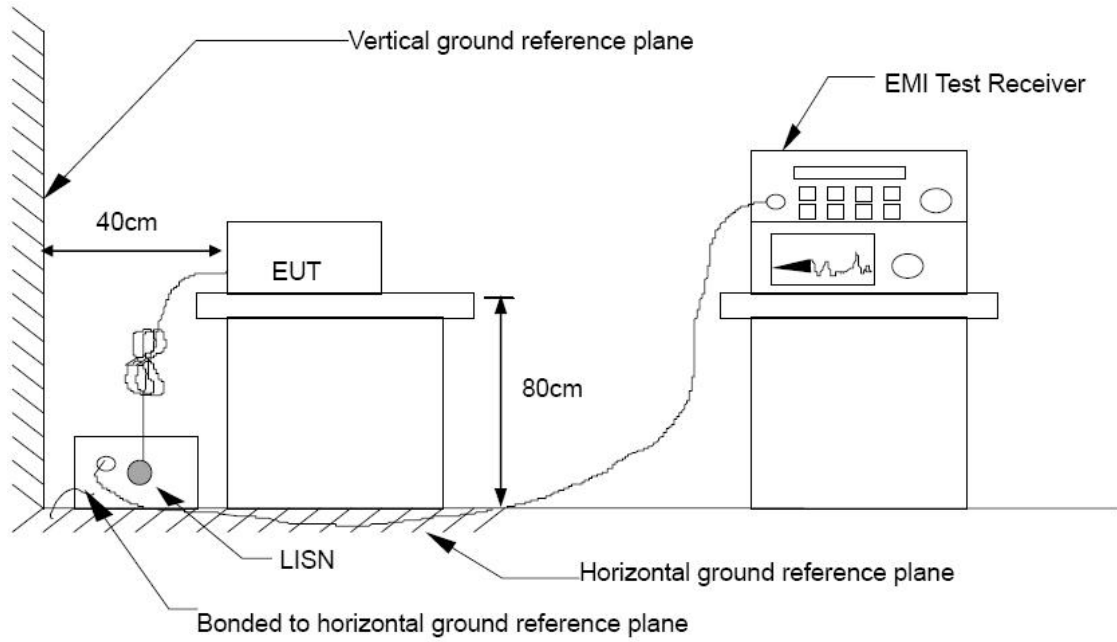



TEST PROCEDURE

The basic test procedure was in accordance with ANSI C63.4:2003.

The test procedure is performed in a 4m x 3m x 2.4m (LxWxH) shielded room.

The EUT along with its peripherals were placed on a 1.0m (W) x 1.5m (L) and 0.8m in height wooden table and the EUT was adjusted to maintain a 0.4 meter space from a vertical reference plane.

The EUT was connected to power mains through a line impedance stabilization network (LISN) which provides 50 ohm coupling impedance for measuring instrument and the chassis ground was bounded to the horizontal ground plane of shielded room. All peripherals were connected to the second LISN and the chassis ground also bounded to the horizontal ground plane of shielded room.

The EUT was located so that the distance between the boundary of the EUT and the closest surface of the LISN is 0.8 m. Where a mains flexible cord was provided by the manufacturer shall be 1 m long, or if in excess of 1 m, the excess cable was folded back and forth as far as possible so as to form a bundle not exceeding 0.4 m in length.

TEST RESULTS

Since the EUT is powered by DC source from system, this test item is not applicable.



APPENDIX I MAXIMUM PERMISSIBLE EXPOSURE

According to FCC 1.1310 : The criteria listed in the following table shall be used to evaluate the environment impact of human exposure to radio frequency (RF) radiation as specified in 1.1307(b) LIMITS FOR MAXIMUM PERMISSIBLE EXPOSURE (MPE)

Frequency Range (MHz)	Electric Field Strength (V/m)	Magnetic Field Strength (A/m)	Power Density (mW/cm ²)	Average Time
(A) Limits for Occupational / Control Exposures				
300-1,500	--	--	F/300	6
1,500-100,000	--	--	5	6
(B) Limits for General Population / Uncontrol Exposures				
300-1,500	--	--	F/1500	6
1,500-100,000	--	--	1	30

CALCULATIONS

Given $E = \frac{\sqrt{30 \times P \times G}}{d}$ & $S = \frac{E^2}{3770}$

Where *E* = Field strength in Volts / meter

P = Power in Watts

G = Numeric antenna gain

d = Distance in meters

S = Power density in milliwatts / square centimeter

Combining equations and re-arranging the terms to express the distance as a function of the remaining variables yields:

$$S = \frac{30 \times P \times G}{3770d^2}$$

Changing to units of mW and cm, using:

$$P (mW) = P (W) / 1000 \text{ and}$$

$$d (cm) = d(m) / 100$$

Yields

$$S = \frac{30 \times (P/1000) \times G}{3770 \times (d/100)^2} = 0.0796 \times \frac{P \times G}{d^2}$$

Where *d* = Distance in cm

P = Power in mW

G = Numeric antenna gain

S = Power density in mW / cm²



LIMIT

Power Density Limit, $S=1.0\text{mW}/\text{cm}^2$

TEST RESULTS

Mode	Antenna Gain (dBi)	Minimum separation distance (cm)	Output Power (dBm)	Numeric antenna gain	Power Density Limit (mW/cm^2)	Power Density at 20cm (mW/cm^2)
IEEE 802.11b	1.45	20	18.68	1.4	1.00	0.020498
IEEE 802.11g	1.45	20	24.15	1.4	1.00	0.072230

Remark: For mobile or fixed location transmitters, the maximum power density is $1.0\text{ mW}/\text{cm}^2$ even if the calculation indicates that the power density would be larger.