

Label Location and direction:

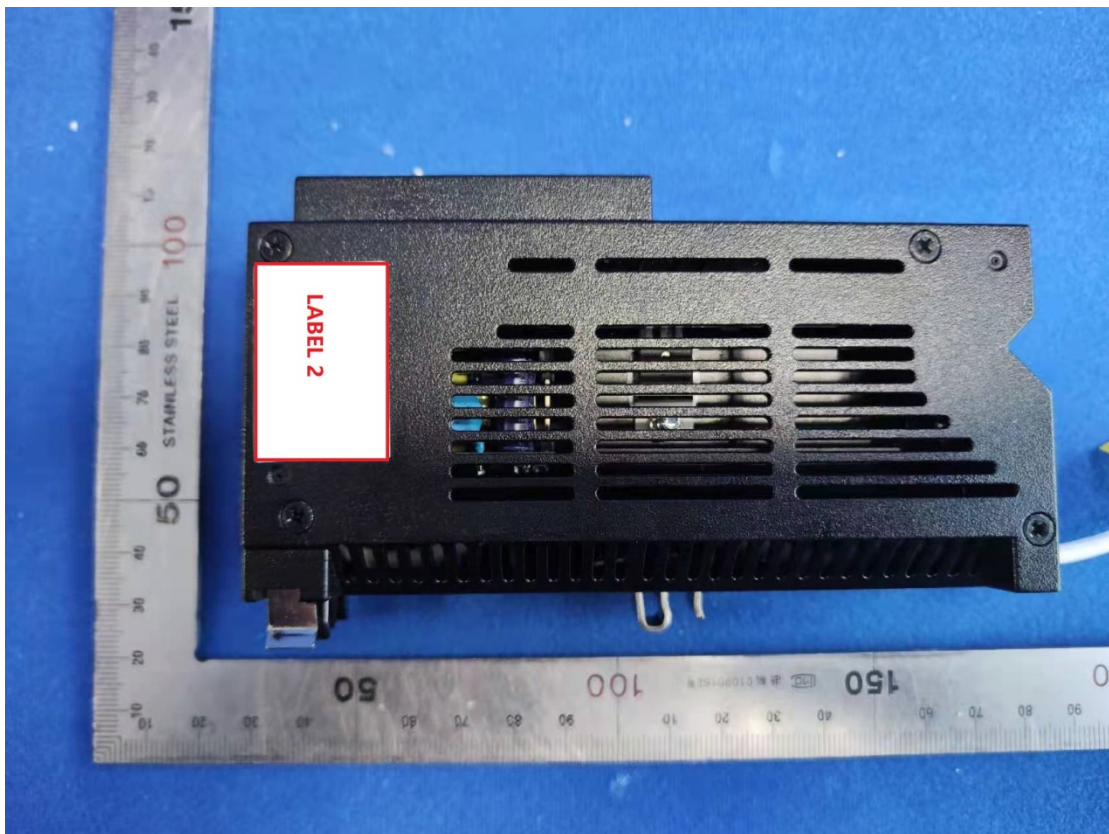
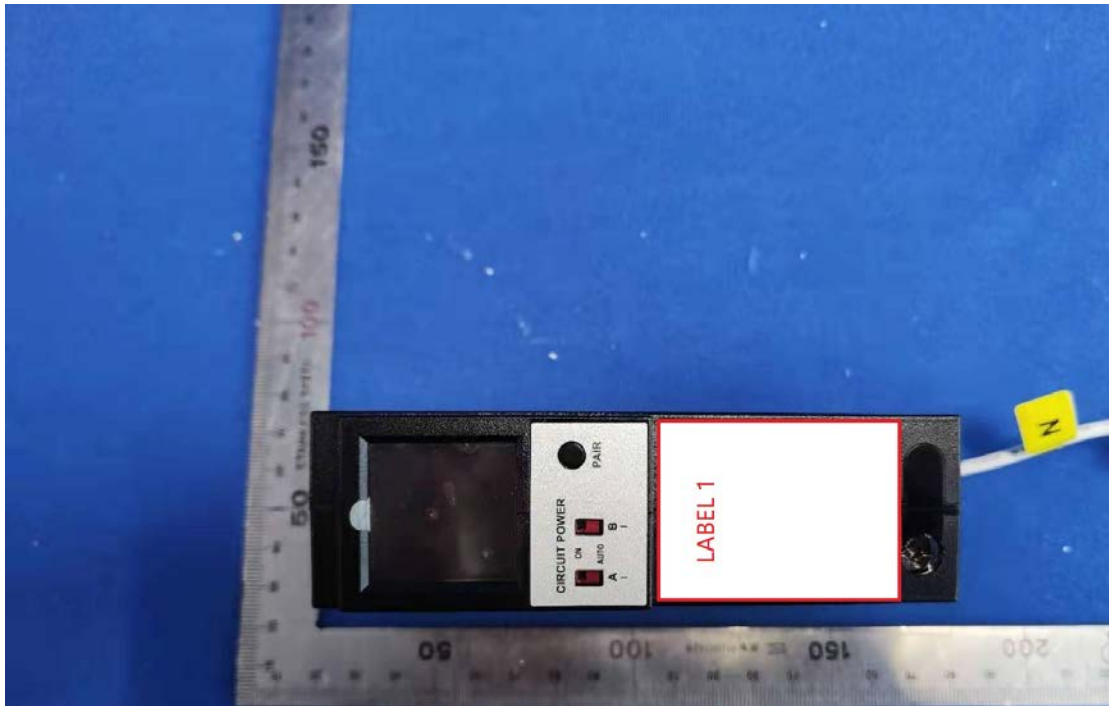

REV	CREATOR	ECO#	DATE	DESCRIPTION
00	UA	XXXXX	11/16/21	INITIAL CREATION

QR DATA FORMAT:
ProductID|Revision|Serial Number|MAC Address

Example:
00C1|00|SQE201200001|001AAE123457

Model number and current revision
Serial number:
Format: CPCYYMMxxxxx
C = Contract Manufacturer (in this case S for Sheenway)
PC = Product Code
YY = Year of Manufacture
MM = Month of Manufacture
xxxxx = Sequential Number

UID = MAC Address + ProductID
MAC Address:
MAC MUST start
MUST start with Savant 001AAE
MUST end with an odd character
ProductID:
LAST four digits AFTER MAC Address



Label 2 of GPM-Q2FPD05-21

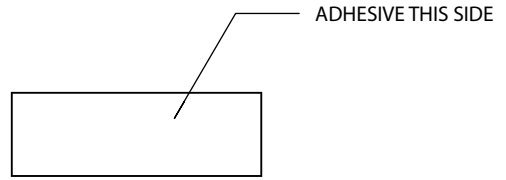

- NOTES: UNLESS OTHERWISE SPECIFIED
- USE 3-D SOURCE FOR FABRICATION. THIS DRAWING IS TO BE USED FOR PART INSPECTION AND CRITICAL DIMENSIONS THAT AFFECT FIT, FORM AND FUNCTION
 - MARK PART NUMBER, REV, DATE, MANUFACTURER ON:
 - A. BULK PACKAGING
 - B. ON PRODUCT AS SHOWN
 - ADHESIVE 3M 467
 - COLOR: SILVER BACKGROUND WITH BLACK C TEXT
 - USE M/N PER P.O.

SCREW TORQUE DATA	TOLERANCE DATA TABLE (UNLESS OTHERWISE SPECIFIED)		
	X	MM	IN
SIZE/ITEM	TORQUE VALUE	X.X	.3
		XXX	.1
		X.XXX	AS NOTED
	ANGLE		1 DEG.
	TORQUE		10%

MATERIAL: SILVER - PERMANENT ADHESIVE	SAVANT SYSTEMS LLC PROPRIETARY & CONFIDENTIAL	45 PERSERVANCE WAY HYANNIS, MA 02601	
	THIS DOCUMENT CONTAINS COMPANY PROPRIETARY INFORMATION AND IS NOT TO BE REPRODUCED OR DISTRIBUTED WITHOUT PRIOR AUTHORIZATION.		TITLE: SAVANT COMPANION SECONDARY LABEL
COLOR: SEE NOTE	SIZE B	UNITS MM	REV 00
	SCALE 1:1	DWG NO 080-XXXX-00	SHEET 65 SHEET

VER	REV	CREATOR	ECO#	DATE	DESCRIPTION
00	00	UA	11977	15DEC21	INITIAL CREATION

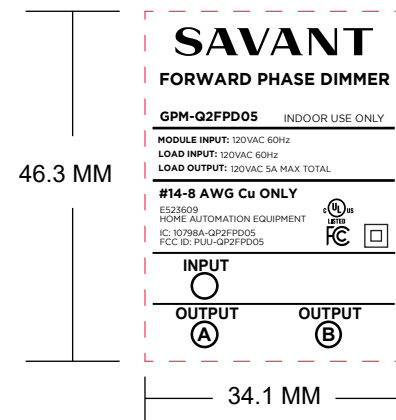

Label 1 of GPM-Q2FPD05-21

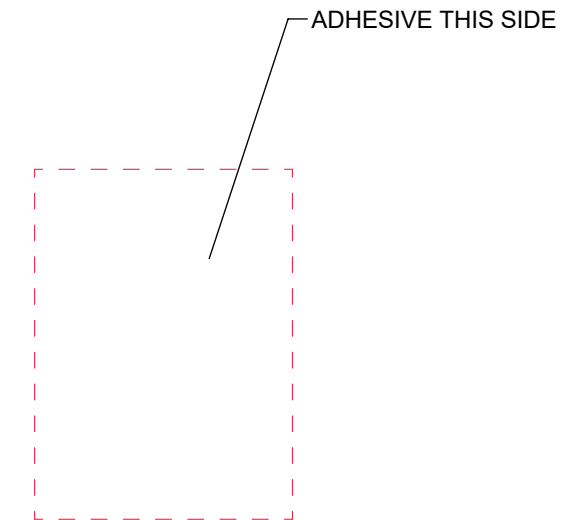
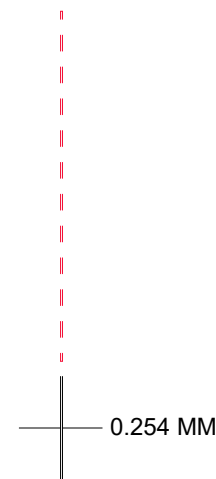

NOTES: UNLESS OTHERWISE SPECIFIED

1. USE 3-D SOURCE FOR PART FABRICATION. THIS DRAWING IS TO BE USED FOR PART INSPECTION AND CRITICAL DIMENSIONS THAT AFFECT FIT, FORM AND FUNCTION

2. MARK PART NUMBER, REV, DATE, MANUFACTURER ON:

- A. BULK PACKAGING
- B. ON PRODUCT AS SHOWN

TOLERANCE DATA TABLE UNLESS OTHERWISE SPECIFIED		
	MM	IN
X	.5	AS NOTED
X.X	.3	±.030
X.XX	.1	±.015
X.XXX	AS NOTED	±.005
ANGLE	± 1 DEG.	
TORQUE	± 10%	

MATERIAL:		SAVANT SYSTEMS LLC PROPRIETARY & CONFIDENTIAL		45 PERSEVERANCE WAY HYANNIS, MA 02601	
FINISH:		THIS DOCUMENT CONTAINS COMPANY PROPRIETARY INFORMATION AND IS NOT TO BE REPRODUCED OR DISTRIBUTED WITHOUT PRIOR AUTHORIZATION			
TITLE					
LABEL, QO FORWARD PHASE DIMMER PIGTAIL					
SIZE	UNITS	DWG NO	VERSION	REV	
B	MM	083-0233-00	00	00	
SCALE	1:1	SHEET	SHEET 1 OF 1		

NOTE: ALL SURFACES
TO BE CLASS B
UNLESS OTHERWISE
SPECIFIED

REV	CREATOR	ECO#	DATE	DESCRIPTION
00	UA	XXXXX	11/16/21	INITIAL CREATION

QR DATA FORMAT:
ProductID|Revision|Serial Number|MAC Address

Example:
00C1|00|SQE201200001|001AAE123457

Model number and current revision
Serial number:
Format: CPCYYMMxxxxx
C = Contract Manufacturer (in this case S for Sheenway)
PC = Product Code
YY = Year of Manufacture
MM = Month of Manufacture
xxxxx = Sequential Number

UID = MAC Address + ProductID
MAC Address:
MAC MUST start
MUST start with Savant 001AAE
MUST end with an odd character
ProductID:
LAST four digits AFTER MAC Address

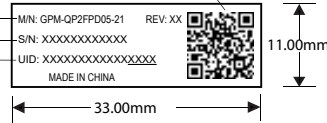

Label 2 of GPM-QP2FPD05-21

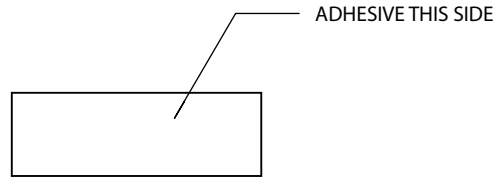

NOTES: UNLESS OTHERWISE SPECIFIED

- USE 3-D SOURCE FOR FABRICATION. THIS DRAWING IS TO BE USED FOR PART INSPECTION AND CRITICAL DIMENSIONS THAT AFFECT FIT, FORM AND FUNCTION
- MARK PART NUMBER, REV, DATE, MANUFACTURER ON:
 - A. BULK PACKAGING
 - B. ON PRODUCT AS SHOWN
- ADHESIVE 3M 467
- COLOR: SILVER BACKGROUND WITH BLACK C TEXT
- USE M/N PER P.O.

SCREW TORQUE DATA	TOLERANCE DATA TABLE (UNLESS OTHERWISE SPECIFIED)		
	X	MM	IN
SIZE/ITEM	TORQUE VALUE	X.X	.3
		XXX	.1
		XXX	AS NOTED
	ANGLE		1 DEG.
	TORQUE		10%

MATERIAL: SILVER - PERMANENT ADHESIVE	SAVANT SYSTEMS LLC PROPRIETARY & CONFIDENTIAL	45 PERSERVERANCE WAY HYANNIS, MA 02601	
	THIS DOCUMENT CONTAINS COMPANY PROPRIETARY INFORMATION AND IS NOT TO BE REPRODUCED OR DISTRIBUTED WITHOUT PRIOR AUTHORIZATION.		TITLE: SAVANT COMPANION SECONDARY LABEL
COLOR: SEE NOTE	SIZE B	UNITS MM	REV 00
	SCALE 1:1	DWG NO 080-XXXX-00	SHEET 65 SHEET

VER	REV	CREATOR	ECO#	DATE	DESCRIPTION
00	00	UA	11977	15DEC21	INITIAL CREATION

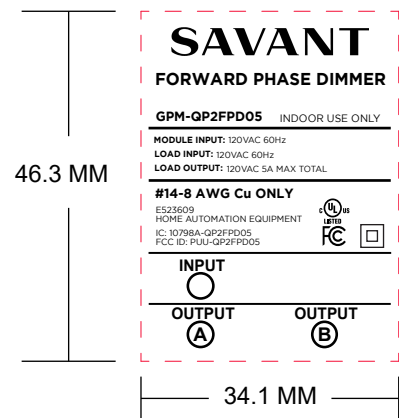

Label 1 of GPM-QP2FPD05-21

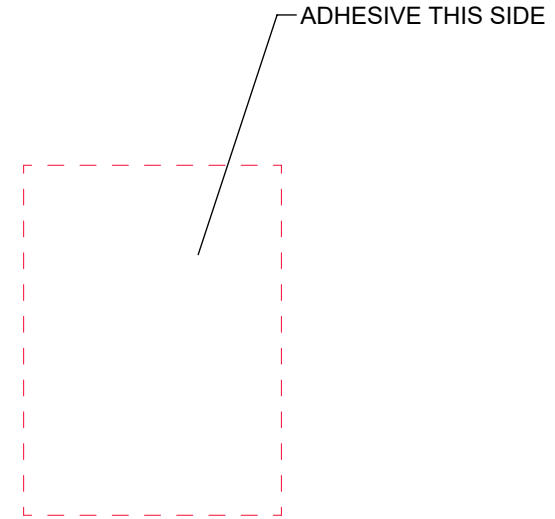
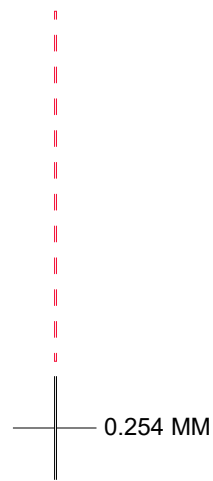

NOTES: UNLESS OTHERWISE SPECIFIED

1. USE 3-D SOURCE FOR PART FABRICATION. THIS DRAWING IS TO BE USED FOR PART INSPECTION AND CRITICAL DIMENSIONS THAT AFFECT FIT, FORM AND FUNCTION

2. MARK PART NUMBER, REV, DATE, MANUFACTURER ON:

- A. BULK PACKAGING
- B. ON PRODUCT AS SHOWN

TOLERANCE DATA TABLE UNLESS OTHERWISE SPECIFIED		
	MM	IN
X	.5	AS NOTED
X.X	.3	±.030
X.XX	.1	±.015
X.XXX	AS NOTED	±.005
ANGLE	± 1 DEG.	
TORQUE	± 10%	

MATERIAL:	SAVANT SYSTEMS LLC PROPRIETARY & CONFIDENTIAL
FINISH:	THIS DOCUMENT CONTAINS COMPANY PROPRIETARY INFORMATION AND IS NOT TO BE REPRODUCED OR DISTRIBUTED WITHOUT PRIOR AUTHORIZATION
NOTE: ALL SURFACES TO BE CLASS B UNLESS OTHERWISE SPECIFIED	

SAVANT		45 PERSEVERANCE WAY HYANNIS, MA 02601		
TITLE LABEL, QO FORWARD PHASE DIMMER PON				
SIZE B	UNITS MM	DWG NO 083-0234-00	VERSION 00	REV 00
SCALE 1:1		SHEET	SHEET 1 OF 1	