

TEST REPORT

Product Name : A21 Speaker Lamp
Model Number : LED+9DA21A/SPK, LED+9DA21A/5K/SPK
FCC ID : PUU-LEDX9DA21G2

Prepared for : GE Lighting
Address : B-6F, NO.6,Xinhua Road, Sanjiao Town, Zhongshan,
Guandong P.R.C

Prepared by : EMTEK (SHENZHEN) CO., LTD.
Address : Bldg 69, Majialong Industry Zone, Nanshan District,
Shenzhen, Guangdong, China

Tel: (0755) 26954280
Fax: (0755) 26954282

Report Number : ES200403014W02
Date(s) of Tests : April 4, 2020 to April 30, 2020
Date of issue : May 7, 2020

§二维码§

Table of Contents

1	TEST RESULT CERTIFICATION.....	3
2	EUT TECHNICAL DESCRIPTION.....	5
3	SUMMARY OF TEST RESULT.....	6
4	TEST METHODOLOGY.....	7
4.1	GENERAL DESCRIPTION OF APPLIED STANDARDS.....	7
4.2	MEASUREMENT EQUIPMENT USED.....	7
4.3	DESCRIPTION OF TEST MODES.....	9
5	FACILITIES AND ACCREDITATIONS.....	9
5.1	FACILITIES.....	9
5.2	LABORATORY ACCREDITATIONS AND LISTINGS.....	9
6	TEST SYSTEM UNCERTAINTY.....	10
7	SETUP OF EQUIPMENT UNDER TEST.....	11
7.1	RADIO FREQUENCY TEST SETUP 1.....	11
7.2	RADIO FREQUENCY TEST SETUP 2.....	11
7.3	CONDUCTED EMISSION TEST SETUP.....	13
7.4	SUPPORT EQUIPMENT.....	13
8	TEST REQUIREMENTS.....	14
8.1	BANDWIDTH TEST.....	14
8.2	RADIATED SPURIOUS EMISSION.....	17
8.3	CONDUCTED EMISSIONS TEST.....	29
8.4	ANTENNA APPLICATION.....	32

1 TEST RESULT CERTIFICATION

This product contains BT, 5.8G, and this report only shows the test results for 5.8G

Applicant : GE Lighting
 Address : 1975 Noble Road, Cleveland, Ohio, United States
 Manufacturer : SHENZHEN FENDA TECHNOLOGY CO., LTD
 Address : Fenda Hi-Tech Park, Zhoushi Road, Shiyao Town, Baoan District, Shenzhen City, Guangdong, China
 EUT : A21 Speaker Lamp
 Model Name : LED+9DA21A/SPK, LED+9DA21A/5K/SPK
 Trademark : 

Measurement Procedure Used:

APPLICABLE STANDARDS	
STANDARD	TEST RESULT
FCC 47 CFR Part 2, Subpart J FCC 47 CFR Part 15, Subpart C	PASS

The above equipment was tested by EMTEK(SHENZHEN) CO., LTD. The test data, data evaluation, test procedures, and equipment configurations shown in this report were made in accordance with the procedures given in ANSI C63.10 (2013) and the energy emitted by the sample EUT tested as described in this report is in compliance with the requirements of FCC Rules Part 2 and Part 15.249

This report applies to above tested sample only and shall not be reproduced in part without written approval of EMTEK (SHENZHEN) CO., LTD.

Date of Test : April 4, 2020 to April 30, 2020

Prepared by : Mill Chen
 Mill Chen /Editor

Reviewer : Sewen Guo
 Sewen Guo /Supervisor

Approve & Authorized Signer : Lisa Wang
 Lisa Wang/Manager



Modified Information

Version	Report No.	Revision Data	Summary
Ver.1.0	ES200403014W02	/	Original Version



2 EUT TECHNICAL DESCRIPTION

Product	A21 Speaker Lamp
Modulation:	LED+9DA21A/SPK, LED+9DA21A/5K/SPK (Note: All models are identical in circuitry and electrical, mechanical and physical construction; the difference are the appearance and model number for trading purpose, we prepared LED+9DA21A/SPK for test.)
Operating Frequency Range:	5731MHz-5795MHz
Transmit Power Max	97.45dBuV/m
Channel number	16 channels
Modulation:	GFSK
Antenna Type:	FPC Antenna
Antenna Gain:	0 dBi
Power supply	AC120V/60Hz
Temperature Range	-20°C ~ +40°C

Note: for more details, please refer to the User's manual of the EUT.

3 SUMMARY OF TEST RESULT

FCC Part Clause	Test Parameter	Verdict	Remark
15.207	Conducted Emission	PASS	
15.209	Radiated Emission	PASS	
15.249	Radiated Spurious Emission	PASS	
15.249	Band edge test	PASS	
15.249	20dB Bandwidth	PASS	
15.203	Antenna Requirement	PASS	
NOTE1: N/A (Not Applicable)			
NOTE2: The report use radiated measurements in the restricted frequency bands. In addition, the radiated test is also performed to ensure the emissions emanating from the device cabinet also comply with the applicable limits.			

RELATED SUBMITTAL(S) / GRANT(S):

This submittal(s) (test report) is intended for FCC ID: PUU-LEDX9DA21G2 filing to comply with Section 15.249 of the FCC Part 15, Subpart C Rules.

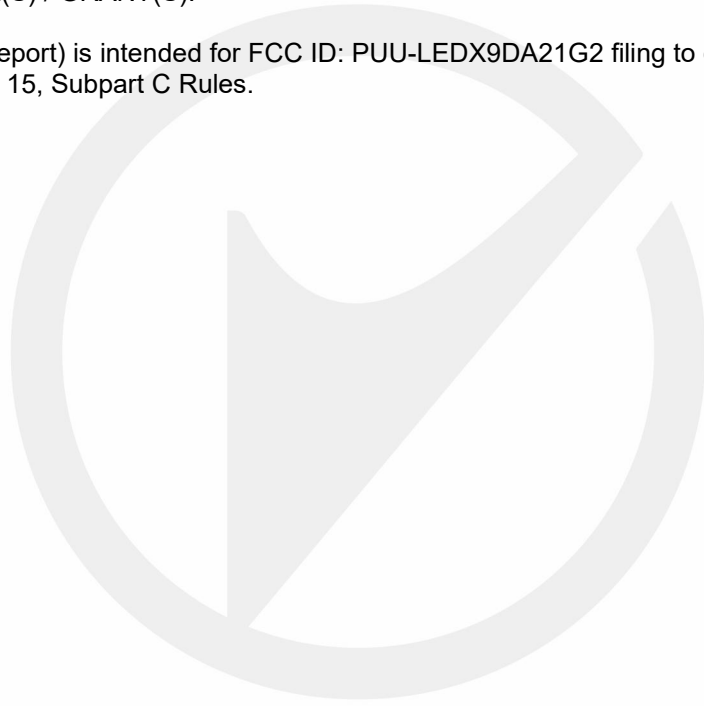

4 TEST METHODOLOGY

4.1 GENERAL DESCRIPTION OF APPLIED STANDARDS

According to its specifications, the EUT must comply with the requirements of the following standards:
 FCC 47 CFR Part 2, Subpart J
 FCC 47 CFR Part 15, Subpart C

4.2 MEASUREMENT EQUIPMENT USED

4.2.1 Conducted Emission Test Equipment

EQUIPMENT TYPE	MFR	MODEL NUMBER	SERIAL NUMBER	LAST CAL.	DUE CAL.
Test Receiver	Rohde & Schwarz	ESCS30	828985/018	05/19/2019	05/18/2020
L.I.S.N.	Schwarzbeck	NNLK8129	8129203	05/19/2019	05/18/2020
50Ω Coaxial Switch	Anritsu	MP59B	M20531	05/19/2019	05/18/2020
Pulse Limiter	Rohde & Schwarz	ESH3-Z2	100006	05/19/2019	05/18/2020
Voltage Probe	Rohde & Schwarz	TK9416	N/A	05/19/2019	05/18/2020
I.S.N	Rohde & Schwarz	ENY22	1109.9508.02	05/19/2019	05/18/2020

4.2.2 For 3m Radiated Emission Measurement 30M-1G (3m chamber 1#)

Equipment	Manufacturer	Model No.	Serial No.	Last Cal.	Cal. Interval
EMI Test Receiver	Rohde & Schwarz	ESU	1302.6005.26	05/19/2019	05/18/2020
Pre-Amplifier	HP	8447F	2944A07999	05/19/2019	05/18/2020
Bilog Antenna	Schwarzbeck	VULB9163	142	05/19/2019	05/18/2020
Cable	Schwarzbeck	AK9513	ACRX1	05/19/2019	05/18/2020
Cable	Rosenberger	N/A	FP2RX2	05/19/2019	05/18/2020
Cable	Schwarzbeck	AK9513	CRPX1	05/19/2019	05/18/2020
Cable	Schwarzbeck	AK9513	CRRX2	05/19/2019	05/18/2020

4.2.3 For 3m Radiated Emission Measurement 1G-18G (3m chamber 1#)

Equipment	Manufacturer	Model No.	Serial No.	Last Cal.	Cal. Interval
EMI Test Receiver	Rohde & Schwarz	ESU	1302.6005.26	05/19/2019	05/18/2020
Pre-Amplifier	A.H.	PAM-0126	1415261	05/19/2019	05/18/2020
Horn Antenna	Schwarzbeck	BBHA 9120	707	05/19/2019	05/18/2020
Cable	H+B	0.5M SF104-26.5	289147/4	05/19/2019	05/18/2020
Cable	H+B	3M SF104-26.5	295838/4	05/19/2019	05/18/2020
Cable	H+B	6M SF104-26.5	295840/4	05/19/2019	05/18/2020

4.2.4 For 3m Radiated Emission Measurement 18G-26.5G (3m chamber 1#)

Equipment	Manufacturer	Model No.	Serial No.	Last Cal.	Cal. Interval
EMI Test Receiver	Rohde & Schwarz	ESU	1302.6005.26	05/19/2019	05/18/2020
Pre-Amplifier	A.H.	PAM-0126	1415261	05/19/2019	05/18/2020
Horn Antenna	Schwarzbeck	BBHA 9170	BBHA9170399	05/19/2019	05/18/2020
Cable	H+B	0.5M SF104-26.5	289147/4	05/19/2019	05/18/2020
Cable	H+B	3M SF104-26.5	295838/4	05/19/2019	05/18/2020
Cable	H+B	6M SF104-26.5	295840/4	05/19/2019	05/18/2020

4.2.5 Radio Frequency Test Equipment

EQUIPMENT TYPE	MFR	MODEL NUMBER	SERIAL NUMBER	LAST CAL.	DUE CAL.
Spectrum Analyzer	Agilent	E4407B	88156318	05/19/2019	05/18/2020
Signal Analyzer	Agilent	N9010A	My53470879	05/19/2019	05/18/2020
Power meter	Anritsu	ML2495A	0824006	05/19/2019	05/18/2020
Power sensor	Anritsu	MA2411B	0738172	05/19/2019	05/18/2020
Spectrum Analyzer	Rohde & Schwarz	FSV40	100967	05/19/2019	05/18/2020

Remark: Each piece of equipment is scheduled for calibration once a year.

4.3 DESCRIPTION OF TEST MODES

The EUT configuration for testing is installed on RF field strength measurement to meet the Commissions requirement and operating in a manner which intends to maximize its emission characteristics in a continuous normal application.

The Transmitter was operated in the normal operating mode. The TX frequency was fixed which was for the purpose of the measurements.

Test of channel included the lowest and middle and highest frequency to perform the test, then record on this report.

5 FACILITIES AND ACCREDITATIONS

5.1 FACILITIES

All measurement facilities used to collect the measurement data are located at

Bldg 69, Majialong Industry Zone District, Nanshan District, Shenzhen, China

The sites are constructed in conformance with the requirements of ANSI C63.7, ANSI C63.10 and CISPR Publication 22.

5.2 LABORATORY ACCREDITATIONS AND LISTINGS

Site Description
EMC Lab.

: Accredited by CNAS, 2018.11.30
The certificate is valid until 2022.10.28
The Laboratory has been assessed and proved to be in compliance with CNAS-CL01:2006 (identical to ISO/IEC 17025:2017)
The Certificate Registration Number is L2291

Accredited by FCC, August 09, 2018
Designation Number: CN1204
Test Firm Registration Number: 882943
Accredited by A2LA, August 08, 2018
The Certificate Registration Number is 4321.01

Accredited by Industry Canada, November 09, 2018
The Conformity Assessment Body Identifier is CN0008

Name of Firm : EMTEK(SHENZHEN) CO., LTD.
Site Location : Bldg 69, Majialong Industry Zone,
Nanshan District, Shenzhen, Guangdong, China

6 TEST SYSTEM UNCERTAINTY

The following measurement uncertainty levels have been estimated for tests performed on the apparatus:

Parameter	Uncertainty
Radio Frequency	$\pm 1 \times 10^{-5}$
Maximum Peak Output Power Test	$\pm 1.0\text{dB}$
Conducted Emissions Test	$\pm 2.0\text{dB}$
Radiated Emission Test	$\pm 2.0\text{dB}$
Occupied Bandwidth Test	$\pm 1.0\text{dB}$
Band Edge Test	$\pm 3\text{dB}$
All emission, radiated	$\pm 3\text{dB}$
Antenna Port Emission	$\pm 3\text{dB}$
Temperature	$\pm 0.5^\circ\text{C}$
Humidity	$\pm 3\%$

Measurement Uncertainty for a level of Confidence of 95%



7 SETUP OF EQUIPMENT UNDER TEST

7.1 RADIO FREQUENCY TEST SETUP 1

The EUT wireless component's antenna ports(s) of the EUT are connected to the measurement instrument per an appropriate attenuator. The EUT is controlled by PC/software to emit the specified signals for the purpose of measurements.

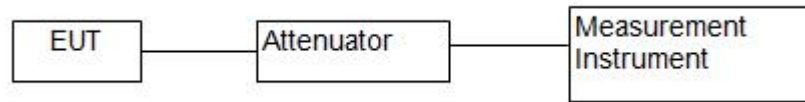

7.2 RADIO FREQUENCY TEST SETUP 2

The test site semi-anechoic chamber has met the requirement of NSA tolerance 4 dB according to the standards: ANSI C63.10. The test distance is 3m. The setup is according to the requirements in Section 13.1.4.1 of ANSI C63.10-2013

Below 30MHz:

The EUT is placed on a turntable 0.8 meters above the ground in the chamber, 3 meter away from the antenna (loop antenna). The Antenna should be positioned with its plane vertical at the specified distance from the EUT and rotated about its vertical axis for maximum response at each azimuth about the EUT. The center of the loop shall be 1 m above the ground. For certain applications, the loop antenna plane may also need to be positioned horizontally at the specified distance from the EUT.

30MHz-1GHz:

The EUT is placed on a turntable 0.8 meters above the ground in the chamber, 3 meter away from the antenna. The maximal emission value is acquired by adjusting the antenna height, polarisation and turntable azimuth. Normally, the height range of antenna is 1 m to 4 m, the azimuth range of turntable is 0° to 360°, and the receive antenna has two polarizations Vertical (V) and Horizontal (H).

Above 1GHz:

The EUT is placed on a turntable 1.5 meters above the ground in the chamber, 3 meter away from the antenna. The maximal emission value is acquired by adjusting the antenna height, polarisation and turntable azimuth. Normally, the height range of antenna is 1 m to 4 m, the azimuth range of turntable is 0° to 360°, and the receive antenna has two polarizations Vertical (V) and Horizontal (H).

(a) Radiated Emission Test Set-Up, Frequency Below 30MHz

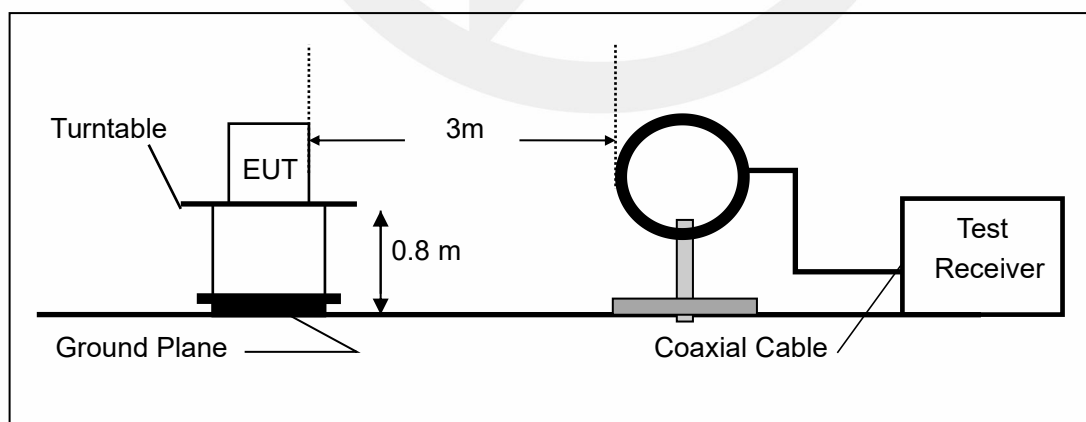

(b) Radiated Emission Test Set-Up, Frequency Below 1000MHz

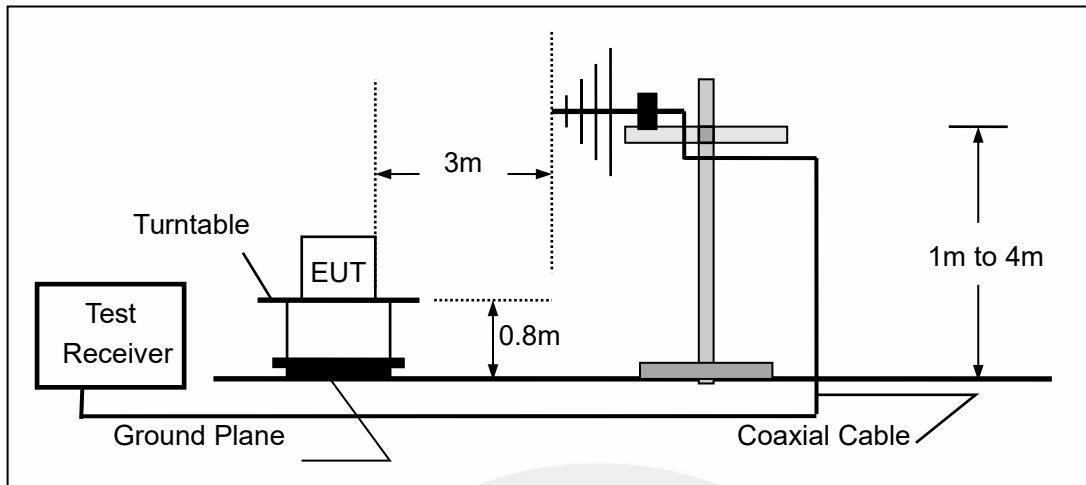

(c) Radiated Emission Test Set-Up, Frequency above 1000MHz

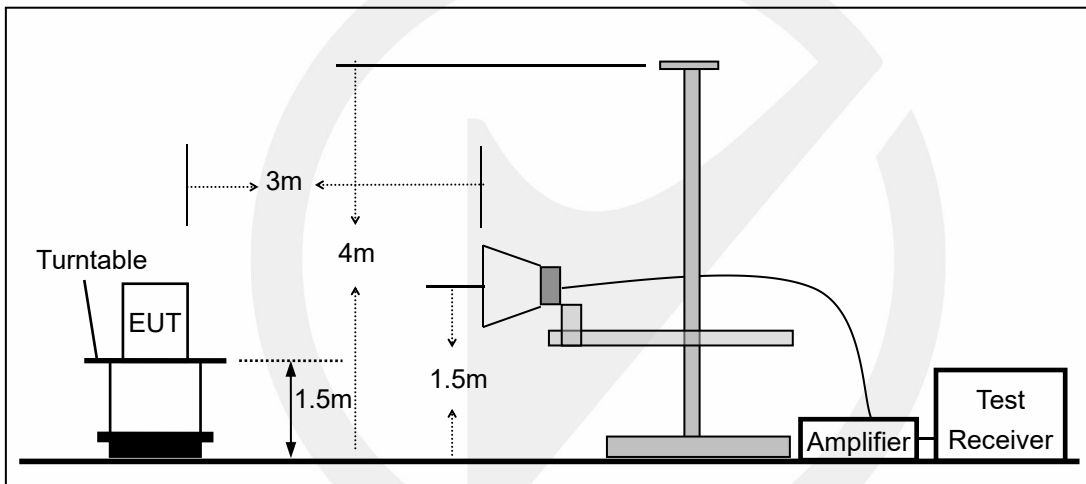

7.3 CONDUCTED EMISSION TEST SETUP

The mains cable of the EUT (maybe per AC/DC Adapter) must be connected to LISN. The LISN shall be placed 0.8 m from the boundary of EUT and bonded to a ground reference plane for LISN mounted on top of the ground reference plane. This distance is between the closest points of the LISN and the EUT. All other units of the EUT and associated equipment shall be at least 0.8m from the LISN.

Ground connections, where required for safety purposes, shall be connected to the reference ground point of the LISN and, where not otherwise provided or specified by the manufacturer, shall be of same length as the mains cable and run parallel to the mains connection at a separation distance of not more than 0.1 m.

According to the requirements in Section 13.1.4.1 of ANSI C63.10-2013 Conducted emissions from the EUT measured in the frequency range between 0.15 MHz and 30 MHz using CISPR Quasi-Peak and average detector mode.

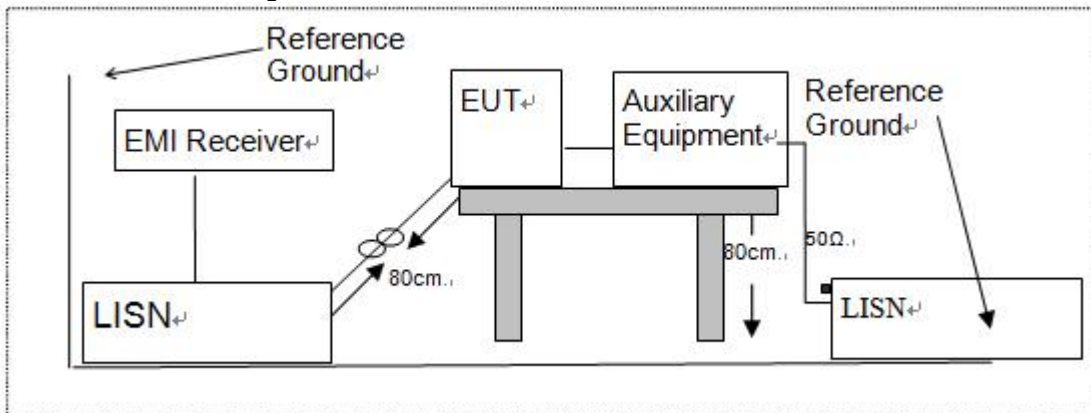

7.4 SUPPORT EQUIPMENT

Description	Manufacturer	Model	Serial Number
iPhone 5C	Apple	A1526	CE, FCC ID

Notes:

1. All the equipment/cables were placed in the worst-case configuration to maximize the emission during the test.
2. Grounding was established in accordance with the manufacturer's requirements and conditions for the intended use.

8 TEST REQUIREMENTS

8.1 BANDWIDTH TEST

8.1.1 Applicable Standard

According to FCC Part 15.249

8.1.2 Conformance Limit

N/A

8.1.3 Test Configuration

Test according to clause 7.1 radio frequency test setup 1

8.1.4 Test Procedure

The EUT was operating in controlled its channel. Printed out the test result from the spectrum by hard copy function.

The RF output of EUT was connected to the spectrum analyzer by RF cable and attenuator. The path loss was compensated to the results for each measurement.

Set to the maximum power setting and enable the EUT transmit continuously

Set RBW \geq 1% of the 20 dB bandwidth.

Set the video bandwidth (VBW) \geq RBW.

Set Span= approximately 2 to 3 times the 20 dB bandwidth.

Set Detector = Peak.

Set Trace mode = max hold.

Set Sweep = auto couple.

Measure the maximum width of the emission that is constrained by the frequencies associated with the two outermost amplitude points (upper and lower frequencies) that are attenuated by 20 dB relative to the maximum level measured in the fundamental emission.

Measure and record the results in the test report.

Test Results

Temperature:	25° C
Relative Humidity:	546%
ATM Pressure:	1009 mbar

Operation Mode	Channel Number	Channel Frequency (MHz)	20db Measurement Bandwidth (kHz)	Limit (kHz)	Verdict
GFSK	Low channel	5731	2171	N/A	PASS
	Mid channel	5767	2156	N/A	PASS
	High channel	5795	2258	N/A	PASS

Test Model 20dB Bandwidth
GFSK
Low Channel: 5731MHz



Date: 29.APR.2020 10:03:10

Test Model 20dB Bandwidth
GFSK
Mid Channel : 5767MHz

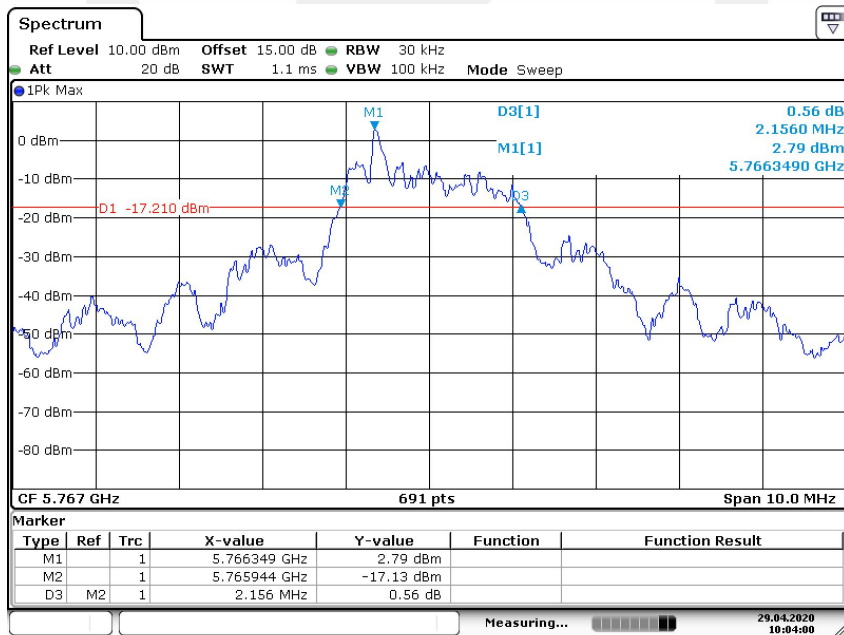

Date: 29.APR.2020 10:04:01

Test Model 20dB Bandwidth
GFSK
High Channel: 5795MHz

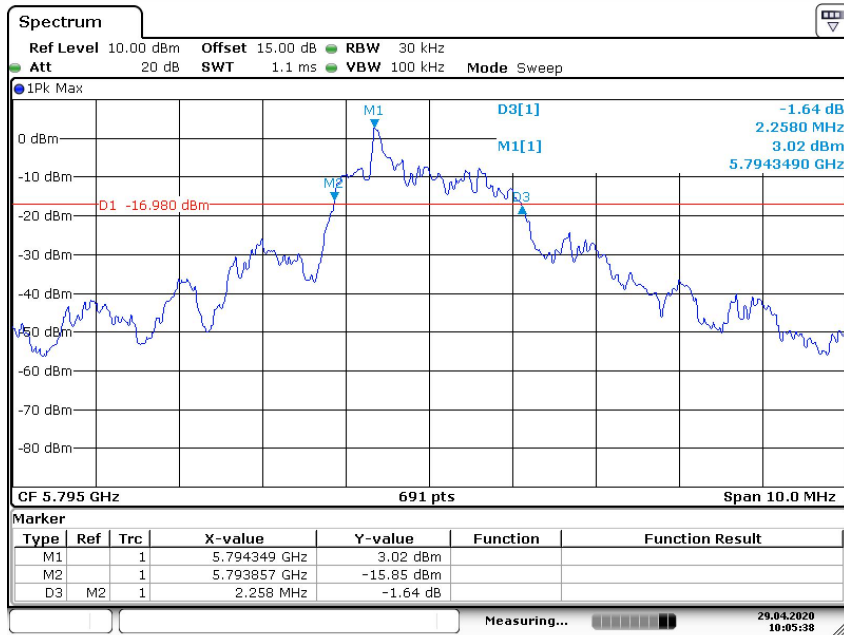

Date: 29.APR.2020 10:05:37



8.2 RADIATED SPURIOUS EMISSION

8.2.1 Applicable Standard

According to FCC Part 15.249 and 15.209

8.2.2 Conformance Limit

According to FCC Part 15.249: radiated emissions which fall in the restricted bands, as defined in §15.205(a), must also comply with the radiated emission limits specified in §15.209(a) (see §15.205(c)).

According to FCC Part 15.205, Restricted bands

MHz	MHz	MHz	GHz
0.090-0.110	16.42-16.423	399.9-410	4.5-5.15
10.495-0.505	16.69475-16.69525	608-614	5.35-5.46
2.1735-2.1905	16.80425-16.80475	960-1240	7.25-7.75
4.125-4.128	25.5-25.67	1300-1427	8.025-8.5
4.17725-4.17775	37.5-38.25	1435-1626.5	9.0-9.2
4.20725-4.20775	73-74.6	1645.5-1646.5	9.3-9.5
6.215-6.218	74.8-75.2	1660-1710	10.6-12.7
6.26775-6.26825	123-138	2200-2300	14.47-14.5
8.291-8.294	149.9-150.05	2310-2390	15.35-16.2
8.362-8.366	156.52475-156.52525	2483.5-2500	17.7-21.4
8.37625-8.38675	156.7-156.9	2690-2900	22.01-23.12
8.41425-8.41475	162.0125-167.17	3260-3267	23.6-24.0
12.29-12.293	167.72-173.2	3332-3339	31.2-31.8
12.51975-12.52025	240-285	3345.8-3358	36.43-36.5
12.57675-12.57725	322-335.4	3600-4400	(2)
13.36-13.41			

According to FCC Part 15.205, the level of any transmitter spurious emission in Restricted bands shall not exceed the level of the emission specified in the following table

Restricted Frequency(MHz)	Field Strength (μV/m)	Field Strength (dBμV/m)	Measurement Distance
0.009-0.490	2400/F(KHz)	20 log (uV/m)	300
0.490-1.705	2400/F(KHz)	20 log (uV/m)	30
1.705-30	30	29.5	30
30-88	100	40	3
88-216	150	43.5	3
216-960	200	46	3
Above 960	500	54	3

Remark :1. Emission level in dBuV/m=20 log (uV/m)

2. Measurement was performed at an antenna to the closed point of EUT distance of meters.

3. Distance extrapolation factor =40log(Specific distance/ test distance)(dB);

Limit line=Specific limits(dBuV) + distance extrapolation factor.

for the frequency ranges below 30 MHz, a narrower RBW is used for these ranges but the measured value should add a RBW correction factor (RBWCF) where RBWCF [dB] =10*Ig(100 [kHz]/narrower RBW [kHz]). , the narrower RBW is 1 kHz and RBWCF is 20 dB for the frequency 9 kHz to 150 kHz, and the narrower RBW is 10 kHz and RBWCF is 10 dB for the frequency 150 kHz to 30 MHz.

Field strength of fundamental and Field strength of harmonics Limit:

Fundamental frequency	Field strength of fundamental (millivolts/meter)	Field strength of harmonics (microvolts/meter)
902-928 MHz	50(94 dBV/m)	500(54 dBV/m)
2400-2483.5 MHz	50(94 dBV/m)	500(54 dBV/m)
5725-5875 MHz	50(94 dBV/m)	500(54 dBV/m)
24.0-24.25 GHz	250(108 dBV/m)	2500(68 dBV/m)

As shown in §15.35(b), for frequencies above 1000 MHz, the field strength limits in paragraphs (a) and (b) of this section are based on average limits. However, the peak field strength of any emission shall not exceed the maximum permitted average limits specified above by more than 20 dB under any condition of modulation

For this report

Fundamental Frequency	Field Strength Of Fundamental	Field Strength of Spurious Emissions
5725-5875 MHz	AV:94 dBuV/m at 3m distance	AV:54 dBuV/m at 3m distance
	PK:114 dBuV/m at 3m distance	PK:74 dBuV/m at 3m distance

8.2.3 Test Configuration

Test according to clause 7.2 radio frequency test setup 2

8.2.4 Test Procedure

This test is required for any spurious emission that falls in a Restricted Band, as defined in Section 15.205. It must be performed with the highest gain of each type of antenna proposed for use with the EUT. Use the following spectrum analyzer settings:

The EUT was placed on a turn table which is 0.8m above ground plane.

Maximum procedure was performed on the highest emissions to ensure EUT compliance.

Span = wide enough to fully capture the emission being measured

RBW = 1 MHz for $f \geq 1$ GHz(1GHz to 25GHz), 100 kHz for $f < 1$ GHz(30MHz to 1GHz)

VBW \geq RBW

Sweep = auto

Detector function = peak

Trace = max hold

Follow the guidelines in ANSI C63.10-2013 with respect to maximizing the emission by rotating the EUT, measuring the emission while the EUT is situated in three orthogonal planes (if appropriate), adjusting the measurement antenna height and polarization, etc. A pre-amp and a high pass filter are required for this test, in order to provide the measuring system with sufficient sensitivity. Allow the trace to stabilize. The peak reading of the emission, after being corrected by the antenna factor, cable loss, pre-amp gain, etc., is the peak field strength, which must comply with the limit specified in Section 15.35(b). Submit this data.

Now set the VBW to 10 Hz, while maintaining all of the other instrument settings. This peak level, once corrected, must comply with the limit specified in Section 15.209. If the dwell time per channel of the hopping signal is less than 100 ms, then the reading obtained with the 10 Hz VBW may be further adjusted by a "duty cycle correction factor", derived from $20\log(\text{dwell time}/100 \text{ ms})$, in an effort to demonstrate compliance with the 15.209 limit. Submit this data.

Repeat above procedures until all frequency measured was complete.

● Calculation of Average factor

The output field strengths of specification in accordance with the FCC rules specify measurements with an average detector. During the test, a spectrum analyzer incorporating a peak detector was used. Therefore, a reduction factor can be applied to the resultant peak signal level and compared to the limit for measurement instrumentation incorporating an average detector.

The duty cycle is measured in 20ms or the repetition cycle period, whichever is a shorter time frame, the duty cycle is measured by placing the spectrum analyzer to set zero span at 1MHz resolution bandwidth.

8.2.5 Test Results

Temperature:	24° C
Relative Humidity:	58%
ATM Pressure:	1010 mbar

■ Spurious Emission below 30MHz (9KHz to 30MHz)

Freq. (MHz)	Ant.Pol. H/V	Emission Level(dBuV/m)		Limit 3m(dBuV/m)		Over(dB)	
		PK	AV	PK	AV	PK	AV
--	--	--	--	--	--	--	--

Note: the amplitude of spurious emission that is attenuated by more than 20dB below the permissible limit has no need to be reported.

Distance extrapolation factor =40log(Specific distance/ test distance)(dB);

Limit line=Specific limits(dBuV) + distance extrapolation factor

■ Field Strength of the fundamental signal

Freq. (MHz)	Ant.Pol. H/V	Emission Level(dBuV/m)			Limit 3m(dBuV/m)		Over(dB)	
		PK	AV factory	AV	PK	AV	PK	AV
5731.0	V	92.63	-22.61	70.02	114	94	-21.37	-23.98
5731.0	H	97.45	-22.61	74.84	114	94	-16.55	-19.16
5767.0	V	89.48	-22.61	66.87	114	94	-24.52	-27.13
5767.0	H	92.51	-22.61	69.9	114	94	-21.49	-24.1
5795.0	V	91.52	-22.61	68.91	114	94	-22.48	-25.09
5795.0	H	91.38	-22.61	68.77	114	94	-22.62	-25.23

Note: (1) Correct Factor= Antenna Factor +Cable Loss- Amplifier Gain

(2) Emission Level= Reading Level+Probe Factor +Cable Loss

(3)Averaging factor in dB=20log(duty cycle)

(4)Duty cycle=0.074 (It's been tested)

■ Out of Band Emissions

Test mode	Frequency	Limit	Result
	MHz	dBuV / dBc	
Lowest	5725	<54 dBuV	Pass
Highest	5875	<54 dBuV	Pass

Test Model	Spurious Emission		
	Low	GFSK	H
	Test By: XW		

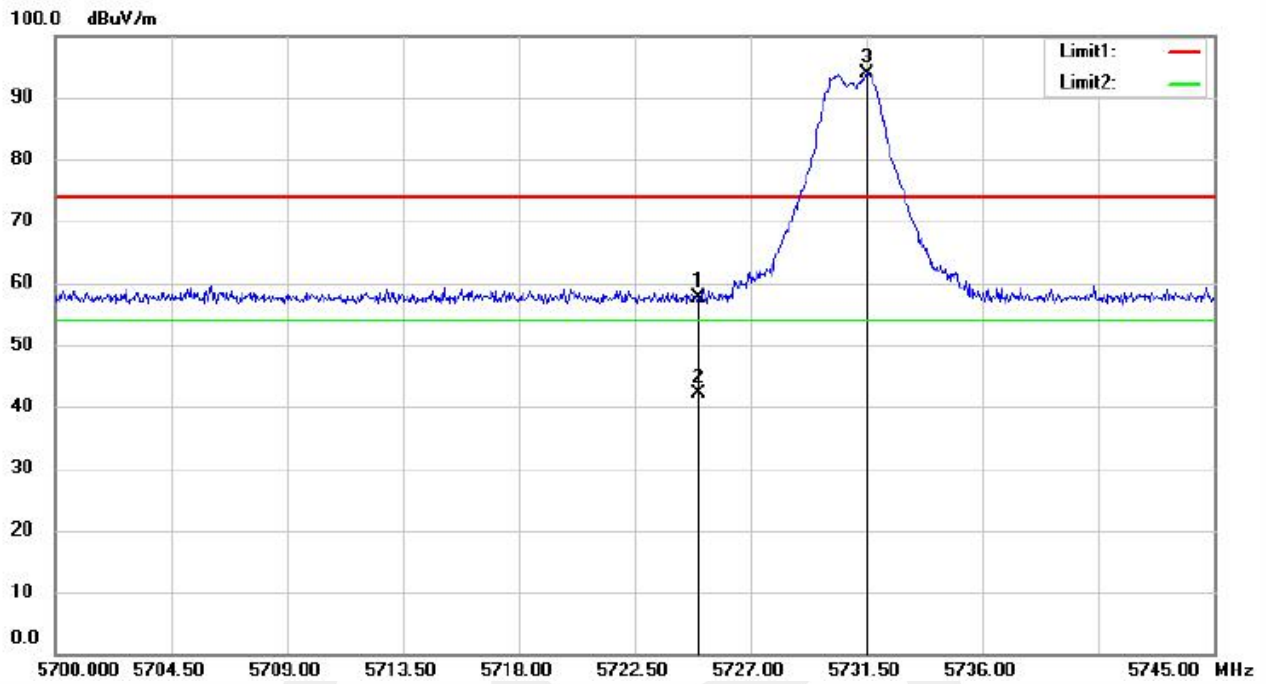

Test Model	Spurious Emission		
	Low	GFSK	V
	Test By: XW		

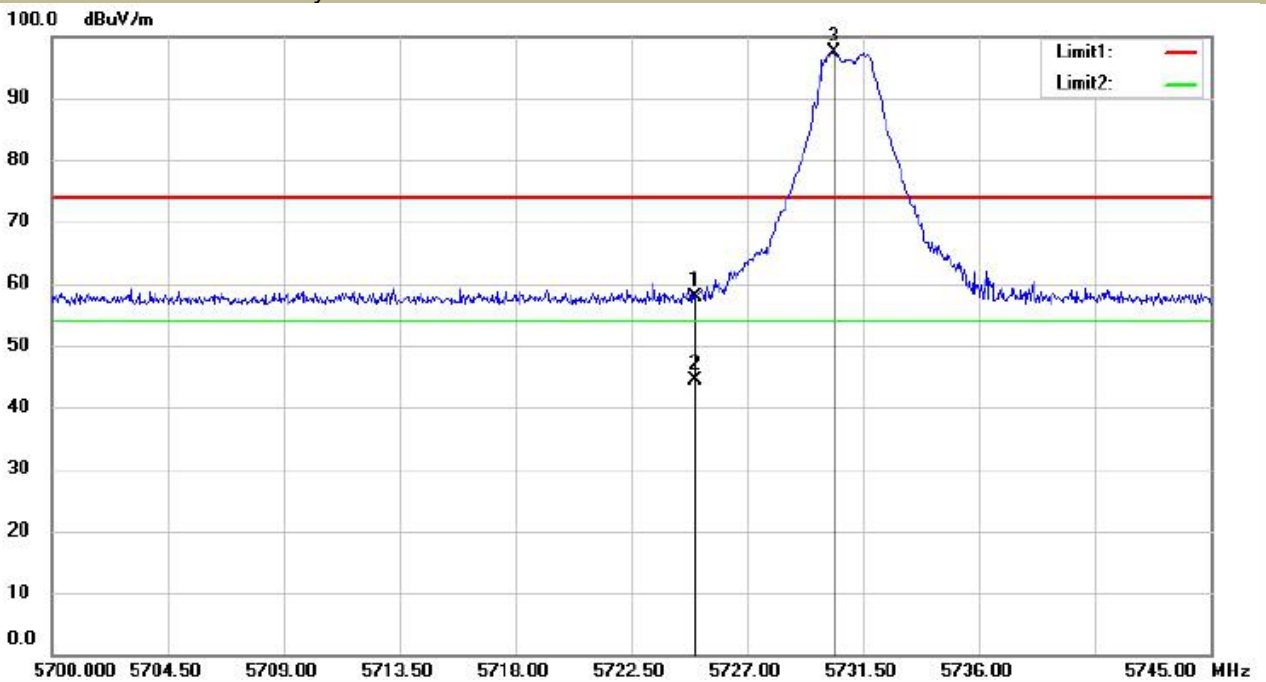

Test Model	Spurious Emission High Test By: XW	GFSK	H
------------	--	------	---

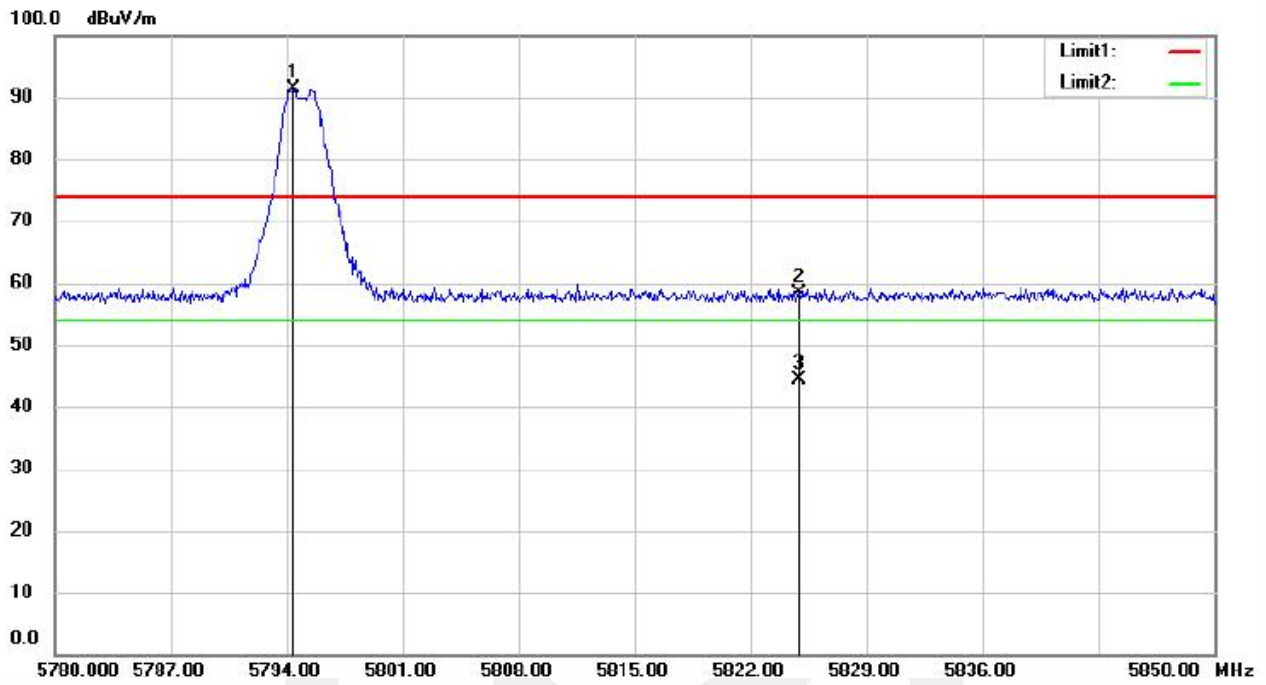

Test Model	Spurious Emission High Test By: XW	GFSK	V
------------	--	------	---

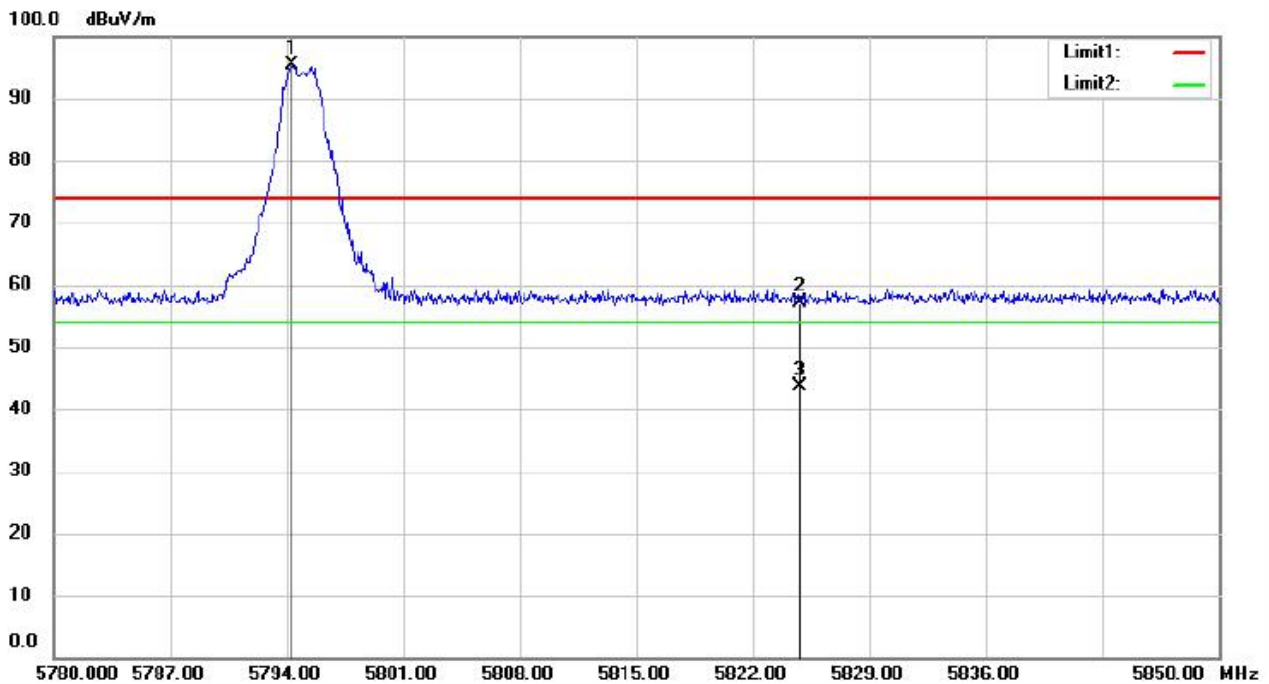

Spurious Emission Above 1GHz (1GHz to 10GHz)

Test mode: GFSK Frequency: Low Channel : 5731MHz

Freq. (MHz)	Ant.Pol. H/V	Emission Level(dBuV/m)		Limit 3m(dBuV/m)		Over(dB)	
		PK	AV	PK	AV	PK	AV
5085.10	V	46.04	32.61	74	54	-27.96	-21.39
12022.80	V	57.43	42.06	74	54	-16.57	-11.94
17693.15	V	61.37	44.14	74	54	-12.63	-9.86
5272.10	H	46.95	32.46	74	54	-27.05	-21.54
12344.10	H	57.02	42.03	74	54	-16.98	-11.97
17660.00	H	60.63	44.00	74	54	-13.37	-10.00

Test mode: GFSK Frequency: Low Channel: 5767MHz

Freq. (MHz)	Ant.Pol. H/V	Emission Level(dBuV/m)		Limit 3m(dBuV/m)		Over(dB)	
		PK	AV	PK	AV	PK	AV
5410.65	V	46.90	33.54	74	54	-27.10	-20.46
12068.70	V	57.06	41.26	74	54	-16.94	-12.74
17656.60	V	60.92	43.87	74	54	-13.08	-10.13
5402.15	H	46.49	32.57	74	54	-27.51	-21.43
12854.95	H	56.88	41.28	74	54	-17.12	-12.72
17593.70	H	60.92	44.01	74	54	-13.08	-9.99

Test mode: GFSK Frequency: Low Channel: 5795MHz

Freq. (MHz)	Ant.Pol. H/V	Emission Level(dBuV/m)		Limit 3m(dBuV/m)		Over(dB)	
		PK	AV	PK	AV	PK	AV
3844.95	V	45.26	32.59	74	54	-28.74	-21.41
11075.05	V	56.53	42.08	74	54	-17.47	-11.92
17635.35	V	60.84	43.76	74	54	-13.16	-10.24
3909.55	H	45.68	33.57	74	54	-28.32	-20.43
12402.75	H	57.63	41.64	74	54	-16.37	-12.36
17675.30	H	61.12	43.61	74	54	-12.88	-10.39

- Note:** ((1) All Readings are Peak Value (VBW=3MHz) and Peak Value (VBW=10Hz).
 (2) Emission Level= Reading Level+Correct Factor +Cable Loss.
 (3) Correct Factor= Ant_F + Cab_L - Preamp
 (4)The reading of emissions are attenuated more than 20dB below the permissible limits or the field strength is too small to be measured.

■ Spurious Emission below 1GHz (30MHz to 1GHz)

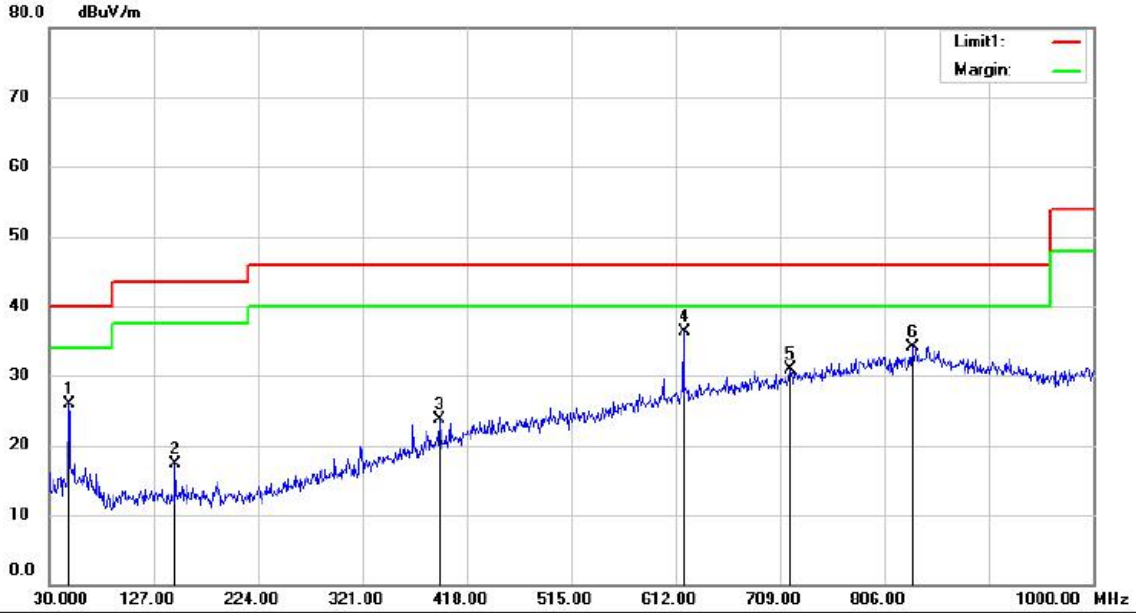

Site 3m Chamber #1 Polarization: **Vertical** Temperature: 29.5 C
 Limit: (RE)FCC PART 15 CLASS B Power: AC 120V/60Hz Humidity: 48 %
 Mode: 5.8G 5731MHz
 Note:

No.	Mk.	Freq. MHz	Reading Level dBuV	Correct Factor dB	Measure- ment dBuV/m	Limit dBuV/m	Over dB	Antenna Height cm	Table Degree degree	Detector	Comment
1		48.4300	38.00	-12.12	25.88	40.00	-14.12			QP	
2		147.3700	31.06	-13.83	17.23	43.50	-26.27			QP	
3		392.7800	30.12	-6.35	23.77	46.00	-22.23			QP	
4	*	619.7600	36.74	-0.46	36.28	46.00	-9.72			QP	
5		718.7000	29.30	1.64	30.94	46.00	-15.06			QP	
6		832.1900	29.40	4.61	34.01	46.00	-11.99			QP	

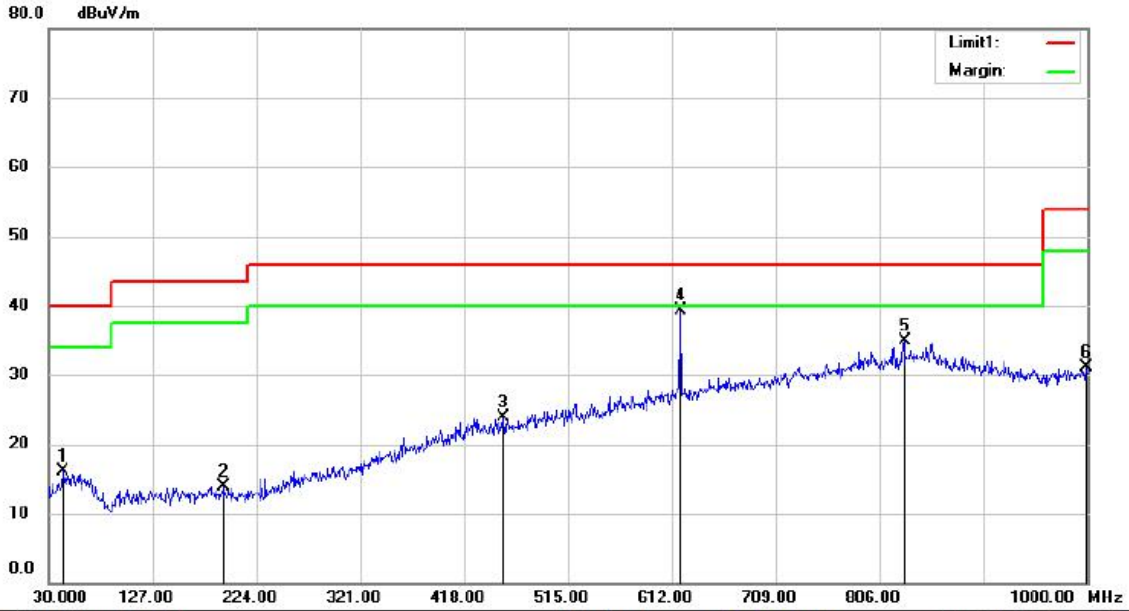

Site 3m Chamber #1 Polarization: **Horizontal** Temperature: 29.5 C
 Limit: (RE)FCC PART 15 CLASS B Power: AC 120V/60Hz Humidity: 48 %
 Mode: 5.8G 5731MHz
 Note:

No.	Mk.	Freq. MHz	Reading Level dBuV	Correct Factor dB	Measure- ment dBuV/m	Limit dBuV/m	Over dB	Antenna Height cm	Table Degree degree	Comment
1		43.5800	28.40	-12.37	16.03	40.00	-23.97	QP		
2		192.9600	27.67	-13.75	13.92	43.50	-29.58	QP		
3		454.8600	28.68	-4.78	23.90	46.00	-22.10	QP		
4	*	620.7300	39.76	-0.46	39.30	46.00	-6.70	QP		
5		829.2800	30.51	4.48	34.99	46.00	-11.01	QP		
6		999.0300	28.48	2.59	31.07	54.00	-22.93	QP		

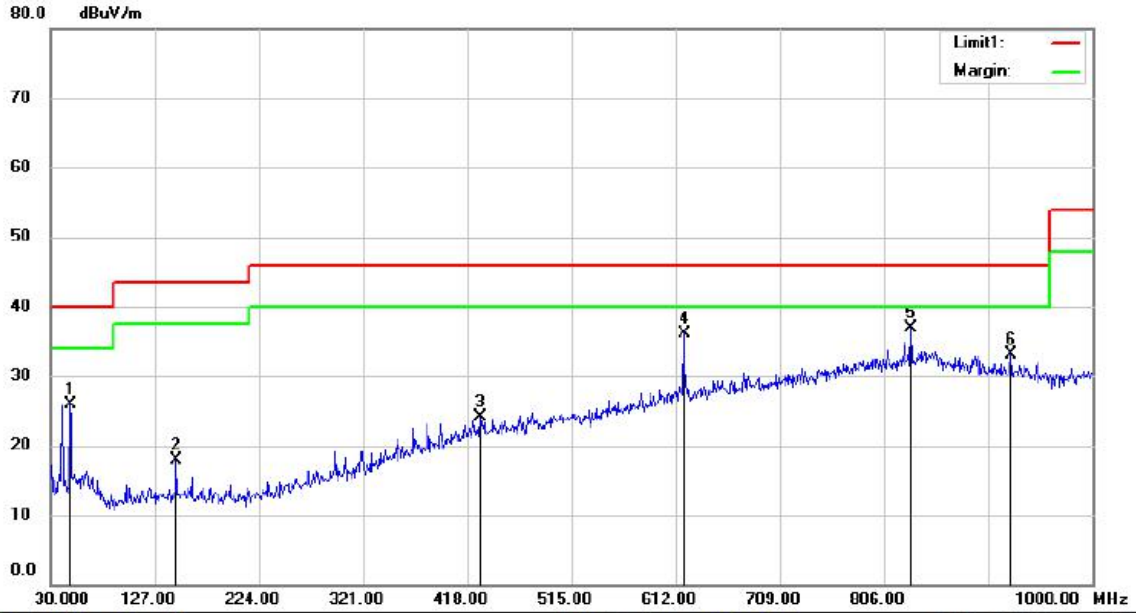

Site: 3m Chamber #1 Polarization: **Vertical** Temperature: 29.5 C
 Limit: (RE)FCC PART 15 CLASS B Power: AC 120V/60Hz Humidity: 48 %
 Mode: 5.8G 5767MHz
 Note:

No.	Mk.	Freq. MHz	Reading Level dBuV	Correct Factor dB	Measure- ment dBuV/m	Limit dBuV/m	Over dB	Antenna Height cm	Table Degree degree	Comment
1		48.4300	38.01	-12.12	25.89	40.00	-14.11	QP		
2		147.3700	31.76	-13.83	17.93	43.50	-25.57	QP		
3		430.6100	29.02	-4.88	24.14	46.00	-21.86	QP		
4		619.7600	36.55	-0.46	36.09	46.00	-9.91	QP		
5	*	831.2200	32.38	4.57	36.95	46.00	-9.05	QP		
6		924.3400	30.52	2.61	33.13	46.00	-12.87	QP		

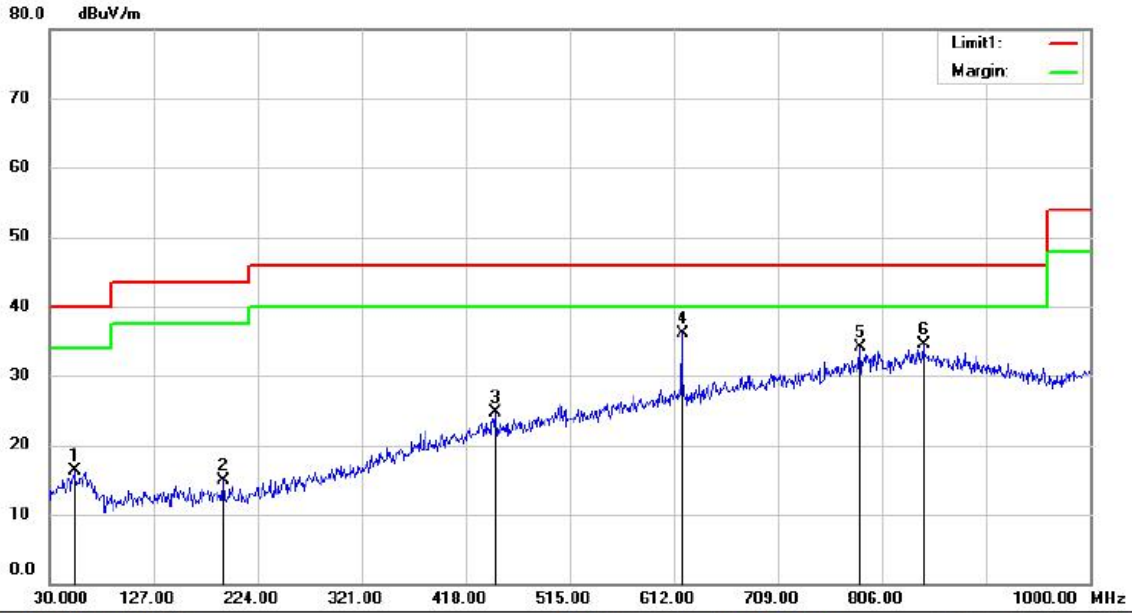

Site 3m Chamber #1 Polarization: **Horizontal** Temperature: 29.5 C
 Limit: (RE)FCC PART 15 CLASS B Power: AC 120V/60Hz Humidity: 48 %
 Mode: 5.8G 5767MHz
 Note:

No.	Mk.	Freq. MHz	Reading Level dBuV	Correct Factor dB	Measure- ment dBuV/m	Limit dBuV/m	Over dB	Antenna Height cm	Table Degree	Detector	Comment
1		53.2800	27.95	-11.62	16.33	40.00	-23.67			QP	
2		191.9900	28.82	-13.83	14.99	43.50	-28.51			QP	
3		445.1600	29.55	-4.87	24.68	46.00	-21.32			QP	
4	*	619.7600	36.59	-0.46	36.13	46.00	-9.87			QP	
5		785.6300	30.46	3.65	34.11	46.00	-11.89			QP	
6		844.8000	29.60	4.93	34.53	46.00	-11.47			QP	

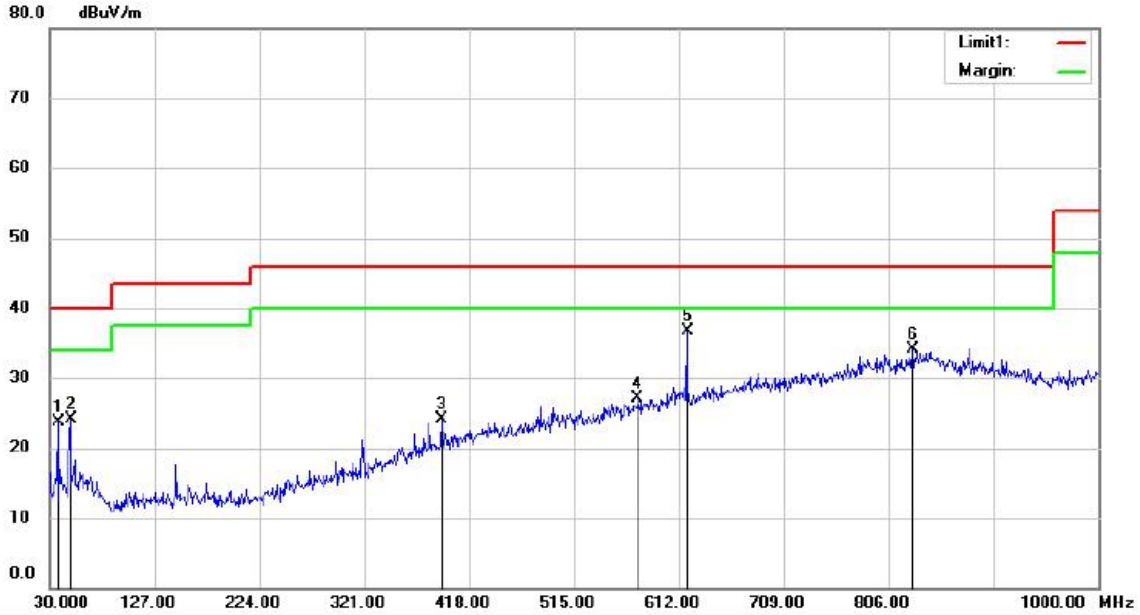

Site: 3m Chamber #1 Polarization: **Vertical** Temperature: 29.5 C
 Limit: (RE)FCC PART 15 CLASS B Power: AC 120V/60Hz Humidity: 48 %
 Mode: 5.8G 5795MHz
 Note:

No.	Mk.	Freq. MHz	Reading Level dBuV	Correct Factor dB	Measure- ment dBuV/m	Limit dBuV/m	Over dB	Antenna Height cm	Table Degree	Detector	Comment
1		37.7600	36.72	-12.96	23.76	40.00	-16.24			QP	
2		49.4000	35.89	-11.87	24.02	40.00	-15.98			QP	
3		392.7800	30.37	-6.35	24.02	46.00	-21.98			QP	
4		574.1700	28.98	-1.78	27.20	46.00	-18.80			QP	
5	*	619.7600	37.12	-0.46	36.66	46.00	-9.34			QP	
6		828.3100	29.71	4.44	34.15	46.00	-11.85			QP	

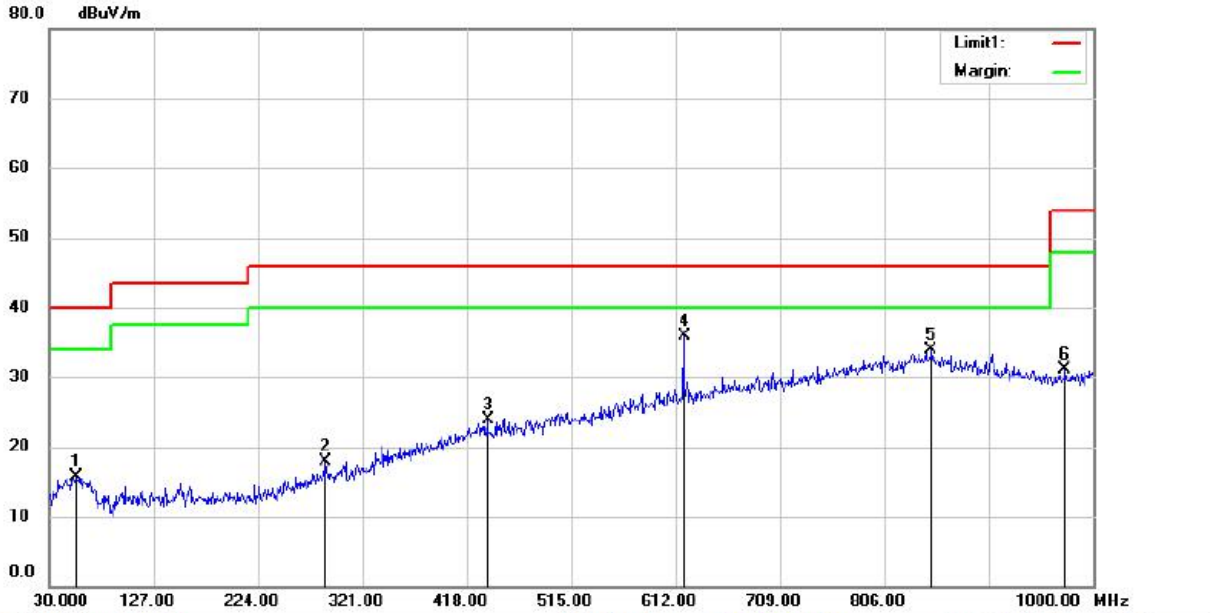

Site: 3m Chamber #1 Polarization: **Horizontal** Temperature: 29.5 C
 Limit: (RE)FCC PART 15 CLASS B Power: AC 120V/60Hz Humidity: 48 %
 Mode: 5.8G 5795MHz
 Note:

No.	Mk.	Freq. MHz	Reading Level dBuV	Correct Factor dB	Measure- ment dBuV/m	Limit dBuV/m	Over dB	Antenna Height cm	Table Degree	Comment
1		55.2200	27.45	-11.73	15.72	40.00	-24.28	QP		
2		287.0500	28.62	-10.73	17.89	46.00	-28.11	QP		
3		437.4000	28.84	-4.97	23.87	46.00	-22.13	QP		
4	*	619.7600	36.41	-0.46	35.95	46.00	-10.05	QP		
5		849.6500	28.98	4.93	33.91	46.00	-12.09	QP		
6		973.8100	29.33	1.72	31.05	54.00	-22.95	QP		

8.3 CONDUCTED EMISSIONS TEST

8.3.1 Applicable Standard

According to FCC Part 15.207(a)

8.3.2 Conformance Limit

Frequency(MHz)	Conducted Emission Limit	
	Quasi-peak	Average
0.15-0.5	66-56	56-46
0.5-5.0	56	46
5.0-30.0	60	50

- Note: 1. The lower limit shall apply at the transition frequencies
2. The limit decreases in line with the logarithm of the frequency in the range of 0.15 to 0.50MHz.

8.3.3 Test Configuration

Test according to clause 7.3 conducted emission test setup

8.3.4 Test Procedure

The EUT was placed on a table which is 0.8m above ground plane.
Maximum procedure was performed on the highest emissions to ensure EUT compliance.
Repeat above procedures until all frequency measured were complete.

8.3.5 Test Results

Pass

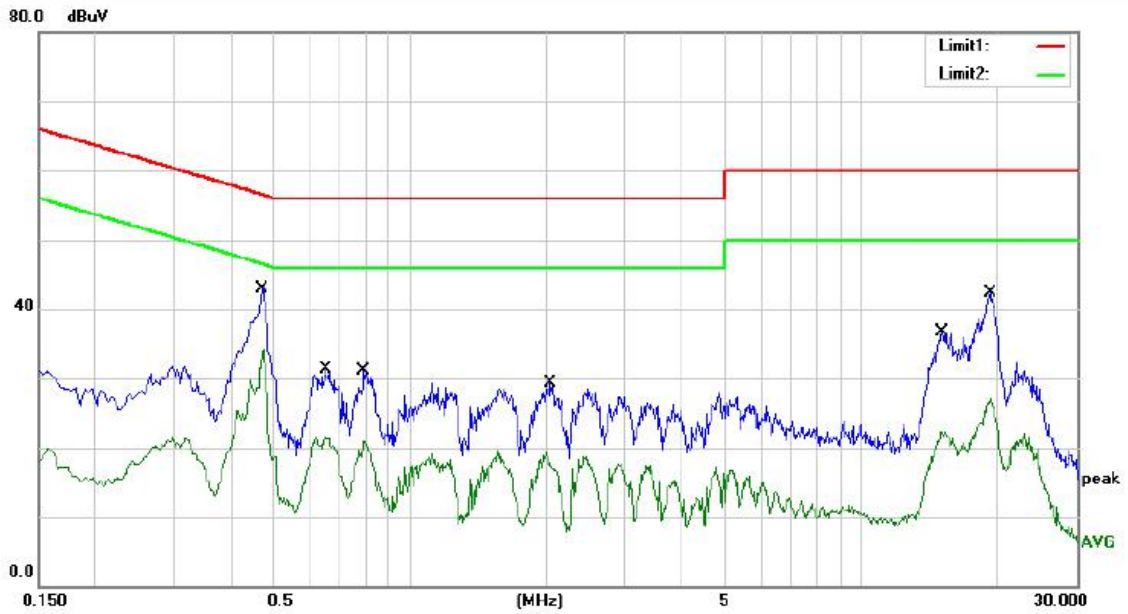

Site Conduction #1

Phase: **L1**

Temperature: 25.4

Limit: (CE)FCC PART 15 class B_QP

Power: AC 120V/60Hz

Humidity: 54 %

Mode: 5.8G

Note:

No.	Mk.	Freq.	Reading Level	Correct Factor	Measurement	Limit	Over	Detector	Comment
		MHz	dBuV	dB	dBuV	dBuV	dB		
1		0.4700	33.30	9.57	42.87	56.51	-13.64	QP	
2	*	0.4700	24.60	9.57	34.17	46.51	-12.34	AVG	
3		0.6500	21.82	9.57	31.39	56.00	-24.61	QP	
4		0.6500	12.03	9.57	21.60	46.00	-24.40	AVG	
5		0.7900	21.47	9.59	31.06	56.00	-24.94	QP	
6		0.7900	11.33	9.59	20.92	46.00	-25.08	AVG	
7		2.0460	19.63	9.61	29.24	56.00	-26.76	QP	
8		2.0460	9.83	9.61	19.44	46.00	-26.56	AVG	
9		15.0780	20.96	15.76	36.72	60.00	-23.28	QP	
10		15.0780	6.62	15.76	22.38	50.00	-27.62	AVG	
11		19.2980	26.33	16.03	42.36	60.00	-17.64	QP	
12		19.2980	11.15	16.03	27.18	50.00	-22.82	AVG	

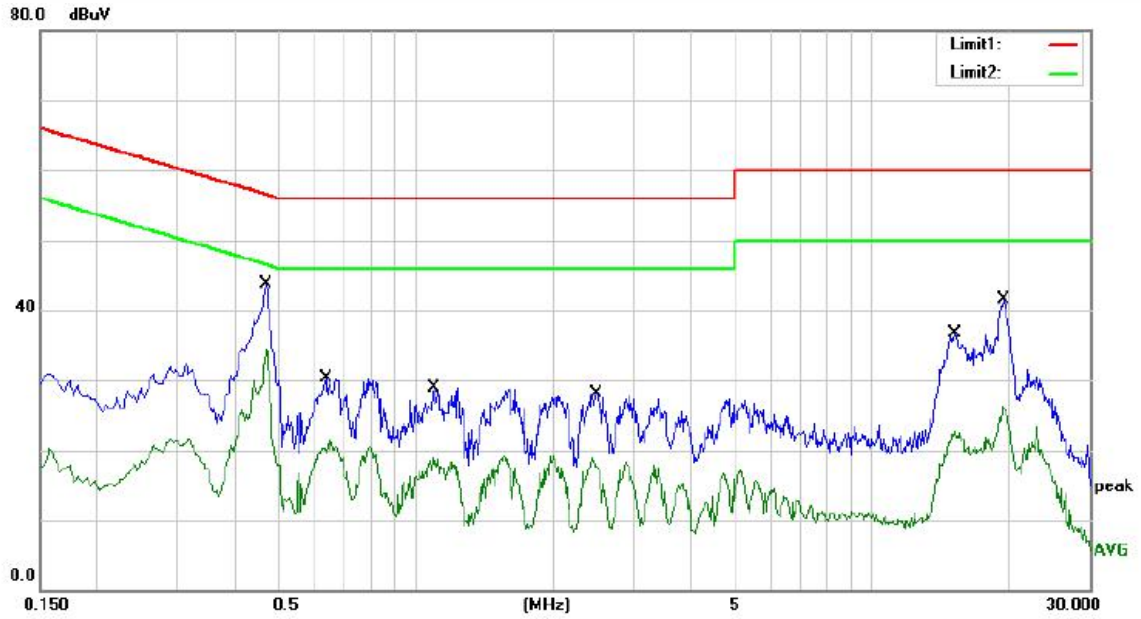

Site Conduction #1 Phase: **N** Temperature: 25.4
 Limit: (CE)FCC PART 15 class B_QP Power: AC 120V/60Hz Humidity: 54 %
 Mode: 5.8G
 Note:

No.	Mk.	Freq.	Reading Level	Correct Factor	Measurement	Limit	Over	Detector	Comment
		MHz	dBuV	dB	dBuV	dBuV	dB		
1		0.4700	34.07	9.57	43.64	56.51	-12.87	QP	
2	*	0.4700	24.78	9.57	34.35	46.51	-12.16	AVG	
3		0.6340	20.78	9.57	30.35	56.00	-25.65	QP	
4		0.6340	11.83	9.57	21.40	46.00	-24.60	AVG	
5		1.0940	19.34	9.59	28.93	56.00	-27.07	QP	
6		1.0940	9.37	9.59	18.96	46.00	-27.04	AVG	
7		2.4900	18.40	9.62	28.02	56.00	-27.98	QP	
8		2.4900	9.30	9.62	18.92	46.00	-27.08	AVG	
9		15.1500	20.90	15.77	36.67	60.00	-23.33	QP	
10		15.1500	6.98	15.77	22.75	50.00	-27.25	AVG	
11		19.4540	25.45	16.04	41.49	60.00	-18.51	QP	
12		19.4540	10.26	16.04	26.30	50.00	-23.70	AVG	

8.4 ANTENNA APPLICATION

8.4.1 Antenna Requirement

Standard	Requirement
FCC CRF Part 15.203	<p>An intentional radiator shall be designed to ensure that no antenna other than that furnished by the responsible party shall be used with the device. The use of a permanently attached antenna or of an antenna that uses a unique coupling to the intentional radiator shall be considered sufficient to comply with the provisions of this section. The manufacturer may design the unit so that a broken antenna can be replaced by the user, but the use of a standard antenna jack or electrical connector is prohibited. This requirement does not apply to carrier current devices or to devices operated under the provisions of §15.211, §15.213, §15.217, §15.219, or §15.221. Further, this requirement does not apply to intentional radiators that must be professionally installed, such as perimeter protection systems and some field disturbance sensors, or to other intentional radiators which, in accordance with §15.31(d), must be measured at the installation site. However, the installer shall be responsible for ensuring that the proper antenna is employed so that the limits in this part are not exceeded.</p>

For intentional device, according to FCC 47 CFR Section 15.203, an intentional radiator shall be designed to ensure that no antenna other than that furnished by the responsible party shall be used with the device.

8.4.2 Result

PASS.

- The EUT is FPC Antenna for 5.8G WiFi, The gain is 0 dBi.

Note:

- Antenna use a permanently attached antenna which is not replaceable.
- Not using a standard antenna jack or electrical connector for antenna replacement
- The antenna has to be professionally installed (please provide method of installation)

which in accordance to section 15.203, please refer to the internal photos.

----- END OF REPORT -----