



RadioFrame Networks

MC-Series Medium-Power System Implementation Guide

The information contained in this document is subject to, and designated as confidential Information of RadioFrame Networks in accordance with, the Mutual Nondisclosure Agreement dated as of October 9, 2002, as amended on September 9, 2004, by and between Nextel Communications, Inc. (Sprint Nextel) and RadioFrame Networks, Inc.

September 18, 2006
998-4005-00 Rev A

Revision History

Date	Rev	Notes
September 18, 2006	A	Initial release

Submit comments and corrections to:

RadioFrame Networks, Inc.
Technical Information Department
9461 Willows Road NE, Suite 100
Redmond, WA 98052
Tel.: +1 425 278 2780 Fax: +1 425 278 2781

<http://www.radioframenetworks.com>

E-mail USinfo@radioframenetworks.com

This document is posted as a .pdf file on the RadioFrame Networks web site at:

<http://www.radioframenetworks.com/partners>

Service Information

This equipment complies with part 15 of the FCC Rules. Operation is subject to the two following conditions: This device may not cause harmful interference, and this device must accept any interference received, including interference that may cause undesired operation. This equipment has been tested and found to comply with the limits pursuant to part 90.691 of the FCC Rules. These limits are designed to provide reasonable protection against harmful interference when the equipment is operated in a commercial environment.

Copyrights and Trademarks

RadioFrame Networks is a trademark or service mark, and RadioFrame, RadioBlade and the RadioFrame Networks logo are registered trademarks of RadioFrame Networks, Inc. You may not use these or any other RadioFrame Networks trademarks or service marks without the written permission of RadioFrame Networks, Inc. All third-party product names and services are the property of their respective owners.

Throughout this publication, the terms RadioFrame Networks, RadioFrame and RFN signify RadioFrame Networks, Inc.

MC-Series Medium-Power System Implementation Guide

© Copyright 2006 RadioFrame Networks, Inc. All Rights Reserved. No part may be reproduced, in any media, except as authorized by written permission of RadioFrame Networks, Inc.

Table of Contents

1	Introduction	10
1.1	References	10
1.2	General Safety Information	10
1.2.1	Static Sensitive Precautions	10
1.2.2	Safety Warnings	11
1.2.2.1	Safety Warnings per Rack Mount Instructions	11
1.2.3	Recommendations	12
1.3	Repair and Technical Support	12
1.3.1	Technical Support	13
1.3.2	Field Replaceable Unit (FRU) Policy	13
2	System Definition	14
2.1	MC-Series Medium Power System Configuration	15
2.2	RadioFrame Networks Hardware	18
2.2.1	BTS Interface Chassis (BIC)	18
2.2.1.1	BIC CRIC	19
2.2.1.2	BPC	19
2.2.1.3	ERTM	19
2.2.1.4	CRTC	20
2.2.1.5	BIC Ports	20
2.2.1.6	BIC Indicators	21
2.2.2	Airlink Interface Chassis (AIC)	21
2.2.2.1	AIC CRIC	22
2.2.2.2	BPC+SPAM	22
2.2.2.3	ERTM	22
2.2.2.4	AIC Ports	23
2.2.2.5	AIC Indicators	23
2.2.3	RadioBlade Shelf (RBS)	23
2.2.3.1	RBS Ports	26
2.2.3.2	RBS Indicators	26
2.2.4	iDEN RadioBlade Transceivers	27
2.2.4.1	800 MHz RadioBlade Transceivers	27
2.2.4.2	Multi-Channel RadioBlade Transceivers	27
2.2.4.3	Combined RadioBlade Transceivers in an RBS	28
2.2.5	Medium Power Dual-Band RF Shelf	28
2.2.6	Power Distribution Unit	30
2.2.7	Cabinet	31
2.3	System Manager Software	31
2.4	Non-RFN Hardware	32
2.4.1	integrated Site Controller (iSC-3) (comes pre-installed)	32
2.4.2	Environmental Alarm System (EAS) (comes pre-installed)	32
2.4.3	Channel Service Unit (CSU) (must be installed)	34
2.4.4	GPS Antenna System (must be installed)	34
2.4.5	Powerplant (must be installed)	34
2.5	Specifications	35
2.5.1	Dimensions	35
2.5.2	Weight	35
2.5.3	Floor Loading	35
2.5.4	Power Requirements	36
2.5.5	Power Consumption	36
2.5.6	Grounding	36
2.5.7	Heat Load	36

2.5.8	RF Performance	37
2.5.8.1	Operating Frequency Bands.....	37
2.5.8.2	Transmitter Performance Summary	37
2.5.8.3	Tx Power Out.....	37
2.5.8.4	Receiver Performance Summary	38
2.5.8.5	Spurious RF Emissions	38
2.5.9	Environmental Specifications	39
2.5.10	Compliance	39
3	Pre-Installation	39
3.1	Site Planning.....	39
3.1.1	Space Requirements.....	40
3.1.2	Floor Loading	40
3.1.3	Anchoring	40
3.1.4	Seismic Zone Installation	40
3.1.5	Cooling of Equipment.....	40
3.1.6	Power	41
3.1.7	Grounding.....	41
3.1.8	GPS Antennas.....	41
3.1.9	T1 Service	41
3.1.10	Alarm Blocks	42
3.1.10.1	Environmental Alarm System (EAS).....	42
3.2	Scheduling / Logistics	42
3.3	MC-Series Medium Power System Installation Kit	43
3.4	iDEN Configuration	43
3.4.1	Cabinet and Position Settings	43
3.4.2	BRs.....	43
3.4.3	Sectorization.....	44
4	Installation.....	44
4.1	Site Inspection	44
4.2	Receipt of Equipment.....	44
4.2.1	Equipment Inspection.....	45
4.2.2	Equipment Inventory	45
4.3	Mounting the MC-Series Medium Power System Cabinet	45
4.3.1	iSC-3s.....	47
4.3.2	EAS	48
4.3.3	CSU	49
4.4	Mounting Auxiliary Equipment	49
4.5	Cabinet-to-Site Cabling.....	50
4.5.1	Grounding.....	50
4.5.2	T1	51
4.5.3	GPS Surge Arrestor	51
4.5.4	EAS Alarm Cabling.....	51
4.5.5	RF (Tx / Rx / Rx diversity)	51
4.5.6	Power	52
5	Final Checkout and Commissioning	52
5.1	Prerequisites	52
5.2	Checkout Procedures	53
5.3	Initial Powering Procedure	53
5.4	System Setup.....	55
5.5	Functionality Test.....	58
6	Management—Datafill, Configuration and Optimization.....	59
6.1	Datafill	59
6.1.1	Unsupported Datafill Parameters	59
6.1.1.1	steThresholdMode.....	59
6.1.1.2	brPwrReducModeAcg.....	59
6.1.2	Parameters that Do Not Apply to the MC-Series Medium Power System	60

6.1.2.1	combinerType.....	60
6.1.3	Recommended Datafill Parameters.....	60
6.1.3.1	PCC.....	60
6.1.3.2	Pto (transmit power).....	60
6.1.4	rxTxGain = 0.....	60
6.1.4.1	defaultTxPower.....	60
6.2	System Manager, Configuration and Optimization.....	61
6.2.1	Navigating System Manager.....	61
6.2.1.1	Logging into System Manager.....	61
6.2.1.2	Changing the System Password.....	62
6.2.2	Configuring the MC-Series Medium Power System.....	63
6.2.2.1	Navigating the System Configuration.....	63
6.2.2.2	Viewing the Status of the RadioBlade Transceivers.....	65
6.2.2.3	Locking and Unlocking a RadioBlade Transceiver.....	67
6.2.2.4	RadioBlade Alarms Page.....	68
6.2.2.5	Changing the Device Name, IP Address or Building Location.....	69
6.2.2.6	Viewing Hardware and Software Versions.....	70
6.2.2.7	Changing the iDEN Configuration.....	71
6.2.3	Optimization Procedures.....	72
6.2.3.1	Local Performance Monitoring.....	72
6.2.3.2	iDEN Uplink Analysis.....	74
6.2.3.3	Voice Loopback Diagnostic Test.....	75
6.2.3.4	System Parameter Information Page.....	76
7	Scheduled and Unscheduled Maintenance.....	78
7.1	Maintenance.....	78
7.2	Annual Maintenance.....	78
7.3	Troubleshooting Guidelines.....	78
7.4	Fault Indications.....	78
7.4.1	BIC.....	79
7.4.2	AIC.....	80
7.4.3	RBS.....	80
7.4.4	RF Shelf.....	81
7.5	System Manager Alarms.....	81
7.5.1	Viewing System Manager Alarms.....	81
7.5.2	OMC Alarm Code.....	83
7.5.3	System Manager Alarms.....	84
7.6	RadioBlade Transceiver Alarm Handling.....	85
7.6.1	RadioBlade Locking Policy.....	86
7.6.1.1	Standby Blade.....	86
7.6.1.2	Locking Policy for RadioBlade Transceiver with Errors.....	86
7.6.1.3	Removal of RadioBlade Transceiver.....	86
7.6.1.4	Administrative Locking of a RadioBlade Transceiver.....	86
7.7	Serial Log Upload Procedure.....	88
7.8	Power Down Procedure.....	90
7.9	Field Replaceable Unit (FRU) Procedures.....	91
7.9.1	RF Shelf.....	91
7.9.1.1	RF Shelf Replacement Procedure.....	92
7.9.1.2	Replacing a Fan in the RBS or an RF Shelf.....	93
7.9.2	Replacing a Chassis: BIC, AIC or RBS.....	94
7.9.2.1	BIC.....	94
7.9.2.2	AIC.....	96
7.9.2.3	RBS.....	97
7.9.3	BIC/AIC– FRU Replacement Procedure.....	99
7.9.3.1	Replacing the CRIC (BIC or AIC).....	99
7.9.3.2	BPC (BIC) or BPC+SPAM (AIC).....	100
7.9.3.3	ERTM.....	102

- 7.9.3.4 CRTC 103
- 7.9.4 RadioBlade Transceiver Replacement..... 104
- 7.9.5 Power Distribution Unit..... 106
- 8 System Configuration Changes 108
 - 8.1 Upgrading MC-Series System Software 108
 - 8.1.1 Download MC-Series System Software to the Laptop Computer 108
 - 8.1.2 Download FTP Server Software to the Laptop Computer..... 108
 - 8.1.2.1 Windows XP Method 108
 - 8.1.2.2 Windows 2000 Method 109
 - 8.1.3 Install the MC-Series System Software Update 112
 - 8.1.4 Verify the Software Download..... 115
 - 8.1.5 Reverting to the previous version of software 116
 - 8.2 Performing a System Reset..... 116
 - 8.3 Adding or Removing RadioBlade Transceivers 117
 - 8.4 Field Replaceable Units (FRUs), Parts and Extra Supplies 117
 - 8.4.1 Matching Terminals for PDU and Ground 117
 - 8.4.2 GPS surge arrester 118
 - 8.4.3 RF Feed-Throughs (N-type connectors) 118
- Appendix A. Definitions and Abbreviations..... 119
- Appendix B. IP Address Requirements 121
- Appendix C. Medium Power iDEN Microcell Rack Stack-Up, 3-Sector (Default) Configuration 122
- Appendix D. Functionality Test Procedures..... 134
 - D.1 Interconnect and Dispatch Setup and Voice Quality Testing 134
 - D.2 Packet Data Service Connection and Latency..... 135
 - D.3 Short Message Service..... 136
 - D.4 Handover and Cell Reselection..... 136
 - D.5 Interconnect Connection Stability and SQE Performance 137
 - D.6 Dispatch Connection Stability 137
 - D.7 Idle SQE Testing and Validation 137
 - D.8 System Self-Recovery Test 138
 - D.9 Packet Data Stability and Throughput..... 138
 - D.10 Validation of 'Unable to Key BR' Alarm 138
- Appendix E. Tx / Rx Curves..... 139
- Appendix F. BER Test Procedure 143
 - F.1 Prerequisites for Testing 143
 - F.2 Test Tool 143
 - F.3 Testing Strategy 143
 - F.4 Equipment Connection/Setup 144
 - F.5 BER Test Procedure 145
 - F.6 Equipment Disconnection 151
 - F.7 BER Test Notes Master 151
- Appendix G. Dangerous RF Emissions Precautions 153

Figures

- Figure 1 The MC-Series Dual-Band System Cabinet 15
- Figure 2 MC-Series System 3-Sector Configuration..... 17
- Figure 3 MC-Series System Functional Diagram 18
- Figure 4 BIC Front View..... 18
- Figure 5 BIC Rear View, Showing Optional 2nd CRTC in the Third Slot..... 19
- Figure 6 BIC CRIC Ports and Indicators 19
- Figure 7 BPC indicators 19
- Figure 8 ERTM Ports and Indicators..... 20

Figure 9	CRTC Ports and Indicators	20
Figure 10	BIC RJ-45 Port Indicators.....	21
Figure 11	AIC Front View	21
Figure 12	AIC Rear View	22
Figure 13	AIC CRIC Ports and Indicators.....	22
Figure 14	BPC+SPAM Indicators	22
Figure 15	ERTM Ports and Indicators	23
Figure 16	AIC RJ-45 Port Indicators.....	23
Figure 17	RBS Group Functional Diagram.....	24
Figure 18	RBS Interior, Top Down View.....	25
Figure 19	RBS Front View.....	25
Figure 20	RBS Rear View.....	26
Figure 21	iDEN 2-Port RadioBlade Transceiver.....	27
Figure 22	MCRB Label Position	28
Figure 23	Dual-Band Medium Power RF Shelf Functional Diagram.....	29
Figure 24	Dual-Band Medium-Power RF Shelf Front View.....	30
Figure 25	Dual-Band Medium-Power RF Shelf Rear View	30
Figure 26	PDU Front View.....	31
Figure 27	PDU Rear View	31
Figure 28	System Manager Main Page.....	32
Figure 29	Punch Block Location within the MC-Series Rack	34
Figure 30	Locations of Non-RFN Hardware in MC-Series Medium Power System Rack.....	46
Figure 31	Connections between the Primary iSC and BIC	48
Figure 32	Connection between EAS Control Port and PDU Status Connectors.....	49
Figure 33	Top of the Rack (TOR), Dual-Band Bulkhead, Cabling and Equipment	50
Figure 34	Location of RBS Side Rail Locking Arms	54
Figure 35	Location of BIC CRIC Laptop Connection Port	55
Figure 36	System Manager Welcome Screen.....	56
Figure 37	System Manager Log-in Window	56
Figure 38	iDEN Configuration Page	57
Figure 39	System Manager Home Page	61
Figure 40	Network Password Pop-up Dialog Box	62
Figure 41	Set System Manager Password Dialog Box	63
Figure 42	BIC Configuration Page Showing AIC, BIC and RBS Status.....	64
Figure 43	RadioBlade Status Page	66
Figure 44	RadioBlade Control Page.....	68
Figure 45	RadioBlade Alarms Page	69
Figure 46	System Configuration Page, BIC Selected Component.....	70
Figure 47	Software Version Information Page.....	71
Figure 48	iDEN Configuration Page	72
Figure 49	Operational Status—Performance Monitoring Page	73
Figure 50	Base Radio Performance Statistics Page	74
Figure 51	Uplink Analyzer Page	75
Figure 52	Voice Loopback Diagnostic Test Page	76
Figure 53	System Parameter Information Page	77
Figure 54	Alarm Log Page.....	82
Figure 55	System Lock All / Unlock All Feature	88
Figure 56	Serial Log Upload Link, Diagnostics Tab	89
Figure 57	Serial Log Upload Page with IP Address Prompt.....	90
Figure 58	RF Shelf Front View	91
Figure 59	RF Shelf Rear View	92
Figure 60	RF Shelf Mounting Screw Locations	93
Figure 61	Fan Mounting Screw Locations.....	94
Figure 62	Front View of BIC Showing Screw Locations.....	95
Figure 63	Front View of AIC Showing Screw Locations.....	97
Figure 64	Front View of RBS Showing Mounting Screws	98

Figure 65	Replacing the CRIC in the BIC or AIC.....	100
Figure 66	Replacing the BPC in the BIC or the BPC+SPAM in the AIC.....	101
Figure 67	Rear of BIC (ERTM and CRTM) and AIC (ERTM Only).....	103
Figure 68	Front View of the RadioBlade Shelf (RBS).....	104
Figure 69	RadioBlade Transceiver in Place.....	105
Figure 70	Seating the RadioBlade Transceiver.....	105
Figure 71	RF Shelf Showing Side-Rail Locking Arm Locations.....	106
Figure 72	PDU, Medium Power Rear View.....	107
Figure 73	PDU, Medium Power Front View.....	107
Figure 74	Executing Wftpd from the Windows XP Laptop Run Dialog Box.....	109
Figure 75	Executing Wftpd from the Windows 2000 Laptop Run Dialog Box.....	109
Figure 76	Wftpd Settings (Bottom of Screen Shot).....	110
Figure 77	General Security Dialog Box Settings.....	110
Figure 78	User / Rights Security Dialog Box Settings.....	111
Figure 79	New-User Name.....	111
Figure 80	Password.....	112
Figure 81	User Name Set in User/Rights Security Dialog Box.....	112
Figure 82	Download and Reset Links.....	114
Figure 83	Software Version Information Page.....	116
Figure 84	PolyPhaser RGT Broadband DC Pass Protector.....	118
Figure 85	TOR Cabling (Underside View), Dual-Band 3-Sector MC-Series System.....	123
Figure 86	RFS to RBS RF Cabling, 3-Sector MC-Series Medium Power System.....	126
Figure 87	Power and Ground Connections, MC-Series Medium Power System, Fully Populated.....	128
Figure 88	Cabling, Site Controller and Interface Chasses, Dual-Band 3-Sector MC-Series System.....	133
Figure 89	800E Band Transmit Filter Frequency Response.....	139
Figure 90	900 MHz Transmit Filter Frequency Response.....	140
Figure 91	800E Band Rx Filter Response.....	141
Figure 92	900 MHz Band Rx Filter Response.....	142
Figure 93	BER Test Flow.....	144
Figure 94	RadioBlade Control Page.....	146
Figure 95	System Diagnostics Page.....	148
Figure 96	Bit Error Rate Test Page.....	149
Figure 97	Bit Error Rate Start Test Page.....	150

Tables

Table 1	FRU Table.....	14
Table 2	Sectorization and Maximum BR Allocation.....	16
Table 3	Ports in the BIC.....	20
Table 4	Ports in the AIC.....	23
Table 5	RBS Ports.....	26
Table 6	RBS Indicator LEDs.....	27
Table 7	PDU Circuit Breaker Overview.....	31
Table 8	Dimensions.....	35
Table 9	Weight.....	35
Table 10	Floor Loading.....	35
Table 11	Power Requirements.....	36
Table 12	Power Consumption per Assembly (See Note).....	36
Table 13	Grounding Resistance at Cabinet (TOR)(See Note).....	36
Table 14	Heat Load.....	36
Table 15	Transmit and Receive Frequencies.....	37
Table 16	Transmitter Performance Summary.....	37
Table 17	TOR Output Power.....	38

Table 18 Receiver Performance Summary	38
Table 19 Environmental Specifications	39
Table 20 Agency Compliances	39
Table 21 Installation Kit Materials List	43
Table 22 Status Color Interpretations	65
Table 23 BIC LED Indications	79
Table 24 AIC LED Indications	80
Table 25 RBS LED Indications	80
Table 26 RF Shelf LED Indications	81
Table 27 Alarm Log Fields	83
Table 28 Alarm Details Fields	83
Table 29 Alarm Code 35009 Properties	84
Table 30 Faults Tracked by the Transceiver	85
Table 31 RadioBlade Transceiver Fault Thresholds for Alarm Generation	85
Table 32 Cables to Disconnect from Rear of RF Shelf x (See NOTE)	92
Table 33 Cables to be Disconnected from the BIC (shown grayed out)	95
Table 34 Cables to be Disconnected from the AIC (shown grayed out)	96
Table 35 Cables to be Disconnected from the Front of RBS 1 (shown grayed out)	98
Table 36 Power and Ground Lugs	117
Table 37 Surge Arrestor Specifications	118
Table 38 Specifications for N-Type Feed-Through Connectors	118
Table 39 Address and Port Numbers for Chassis Boards	121
Table 40 Cable Connections, Top of Rack Dual-Band Bulkhead, 3-Sector Configuration	122
Table 41 Cable Connections, RF Shelf, Dual-Band 3-Sector Configuration	124
Table 42 Cable Connections, RadioBlade Shelf, Dual-Band 3-Sector Configuration	125
Table 43 Cable Connections, PDU, Medium Power 3-Sector Configuration	127
Table 44 Cable Connections, CSU, Dual Band 3-Sector Configuration	129
Table 45 Cable Connections, Primary iSC, Medium Power 3-Sector Configuration	130
Table 46 Cable Connections, EAS, Dual-Band 3-Sector Configuration	131
Table 47 Cable Connections, BIC, Dual-Band 3-Sector Configuration	131
Table 48 Cable Connections, AIC, Dual Band, 3-Sector Configuration	132
Table 49 Interconnect Call Quality, Setup and Stability	134
Table 50 Group Dispatch Call Quality, Setup and Stability	134
Table 51 Private Dispatch Call Quality, Setup and Stability	135
Table 52 Packet Data Latency over the MC-Series System (Ping -n 100 -w 2000 xx.xxx.xxx.x)	135
Table 53 Packet Data Latency over Motorola EBTS	136
Table 54 Handover and Reselection Test Worksheet	137
Table 55 Interconnect Connection Stability Worksheet	137
Table 56 Dispatch Connection Stability Worksheet	137
Table 57 "Unable to Key BR" Alarm Severity Indications	138
Table 58 BER Test Notes Master	152

1 Introduction

This MC-Series Medium Power Implementation Guide provides an overview of the RadioFrame Networks Medium Power Microcell (MC-Series) system and describes standards for installing, modifying and maintaining RadioFrame Networks equipment at Sprint Nextel customer sites. All specifications and requirements pertain to MC-Series system equipment operating in 800 and/or 900 MHz band(s) with medium-power amplification, as required in some Sprint Nextel iDEN (integrated Digital Enhanced Network) installations. RadioFrame Networks recommends reading the entire manual before attempting to install or operate RadioFrame Networks equipment.

1.1 References

In addition to this manual, the following technical manuals are related to the MC-Series Medium-Power system and may be needed for installation or maintenance.

- Generation 3 Site Controller System Manual, Motorola, 68P80801E30-O
- iDEN OMC-R Configuration Management Parameters Technical Manual, Motorola, 68P80802E10
- Channel Service Unit (CSU) manufacturer's documentation
- Cabinet manufacturer's documentation (shipped with MC-Series system)
- Power supply and battery manufacturer's installation and maintenance documentation
- Distributed Antenna System (DAS) manufacturer's documentation
- General Dynamics R2660 Series Communications System Analyzer Operators Manual, 68-P35270C001 Rev F
- Quality Standards—Fixed Network Equipment (FNE) Installation Manual (R56), Motorola, R56 current edition
- National Electrical Code (NEC), current edition
- National Fire Protection Associations (NFPA) Code 70
- ASTM (American Society For Testing and Materials) 488-90
- Bellcore Technical Specifications 1089, GR-63-CORE

1.2 General Safety Information

Read all the notices in this section prior to installing or using the MC-Series Medium Power system or any of its components.

1.2.1 Static Sensitive Precautions

Electrostatic discharge (ESD) can damage equipment and impair electrical circuitry. It occurs when electronic printed circuit cards are improperly handled and can result in complete or intermittent failures.

- Prior to handling, shipping, and servicing equipment, always put on a conductive wrist strap connected to a grounding device to discharge any accumulated static charges. All RFN FRUs ship with a disposable anti-static wrist strap.



Warning!

Use extreme caution when wearing a conductive wrist strap near sources of high voltage. The low impedance provided by the wrist strap also increases the danger of lethal shock should accidental contact with high voltage sources occur.

-
- Place FRUs only on an anti-static mat when removed from the system. The conductive surface must be connected to ground through 100 kΩ.
 - Do not use non-conductive material for packaging FRUs for shipment or storage. Wrap all FRUs with anti-static (conductive) material. Replacement FRUs shipped from the factory are packaged in a conductive material.
 - If possible, retain all original packing material for future use.

1.2.2 Safety Warnings



Warning!

Use extreme caution when wearing a conductive wrist strap near sources of high voltage. The low impedance provided by the wrist strap also increases the danger of lethal shock should accidental contact with high voltage sources occur.



Warning!

Ultimate disposal of this product should be handled according to all national laws and regulations.



Warning!

The user is cautioned that changes or modifications made to the equipment that are not expressly approved by the party responsible for compliance, could void the user's authority to operate the equipment.



Warning!

To ensure FCC compliance of this equipment, it is the user's responsibility to obtain and use only shielded and grounded interface cables.



Warning!

FCC RF Exposure Compliance: FCC RF exposure compliance must be addressed at the time of licensing, as required by the responsible FCC Bureau(s), including antenna co-location requirements of §1.1307(b)(3). The applicable exposure limits, to demonstrate compliance, are specified in FCC Part 1.1310. Additionally, to comply with FCC RF exposure compliance requirements, the antenna(s) used for this transmitter must be fixed-mounted with at least 25 cm separation distance from any person. The installer of the antenna to be used with this transmitter may be required to perform an MPE evaluation and an Environmental Assessment (EA) of the location at the time of licensing per CFR 47 Part 1.1307. Fixed mounted antenna(s) that are co-located with other antenna(s) must satisfy the co-location requirements of Part 1.1307 for satisfying RF exposure compliance

1.2.2.1 Safety Warnings per Rack Mount Instructions

The following or similar rack-mount instructions are included with the installation instructions:

- 1 Elevated Operating Ambient - If installed in a closed or multi-unit rack assembly, the operating ambient temperature of the rack environment may be greater than room ambient. Therefore, consideration should be given to installing the equipment in an environment compatible with the maximum ambient temperature (T_{ma}) specified by the manufacturer.
- 2 Reduced Air Flow - Installation of the equipment in a rack should be such that the amount of air flow required for safe operation of the equipment is not compromised.
- 3 Mechanical Loading - Mounting of the equipment in the rack should be such that a hazardous condition is not achieved due to uneven mechanical loading.
- 4 Circuit Overloading - Consideration should be given to the connection of the equipment to the supply circuit and the effect that overloading of the circuits might have on overcurrent protection and supply wiring. Appropriate consideration of equipment nameplate ratings should be used when addressing this concern.
- 5 Reliable Earthing - Reliable earthing of rack-mounted equipment should be maintained. Particular attention should be given to supply connections other than direct connections to the branch circuit (e.g., use of power strips).

1.2.3 Recommendations

- Do not work alone if potentially hazardous conditions exist.
- Never assume that power is disconnected from a circuit. Always check.
- Look carefully for possible hazards in the work area, such as moist floors, ungrounded extension cables, frayed power cords and missing safety grounds.

1.3 Repair and Technical Support

RadioFrame Networks provides technical support services to Sprint Nextel for the installation, operation and maintenance of RadioFrame Networks equipment. For iSC-3 or T1 related questions follow normal troubleshooting procedures..

Before calling...

Have the following information available prior to contacting RadioFrame Networks Technical Assistance Center (TAC) to minimize downtime:

- Location of the MC-Series system
- MC-Series system software version
- Symptoms of the problem
- If an alarm was generated, the alarm information from the **Alarm Log** in System Manager
- Date the problem was first noticed
- If the problem can be reproduced
- What causes the problem to occur
- Any unusual circumstances contributing to the problem (i.e., loss of power)

1.3.1 Technical Support

For support of RadioFrame Networks equipment, contact the RadioFrame Networks Technical Assistance Center (TAC) at:

(US) 1-800-328-0847

support@radioframenetworks.com

1.3.2 Field Replaceable Unit (FRU) Policy

The MC-Series Medium Power system has been designed so that Field Repairable Units (FRUs) can be replaced to restore normal system operation as quickly as possible. RadioFrame Networks components are individually tested prior to shipment. If RadioFrame Networks equipment should require service or repair, note the following information, and then contact the RadioFrame Networks Technical Assistance Center at (800) 328-0847:

Note: Do not attempt to repair RadioFrame Networks equipment and components in the field.

Note: Always use a static grounding wrist strap before handling any chassis or RadioBlade[®] transceiver.

- Include the serial numbers of the affected equipment.
- Give a clear return address, including:
- Securely package the FRU in its original shipping carton, if available. Otherwise, package in a static protection bag in a well-padded carton.

Table 1 lists current FRU equipment for the MC-Series system. (Note that some items are for 800 MHz and dual-band low-power systems.) Refer to section 7.9, "Field Replaceable Unit (FRU) Procedures" for replacing any of the following equipment. For equipment not supplied by RadioFrame Networks, follow standard Sprint Nextel policies and procedures for FRU replacement.

Table 1 FRU Table

ItemMaster PN	RFN PN	Description
25688	176-7840-xx	800 MHz MC Series iDEN 2-Port RadioBlade Transceiver
25495	176-0870-xx	800 MHz RF Shelf
25496	176-0535-xx	RadioBlade Transceiver Shelf (RBS)
25498	176-0800-xx	MC-15 Airlink Interface Chassis (AIC)
25497	176-0900-xx	MC-15 BTS Interface Chassis (BIC)
25499	176-7570-xx	Base Processing Card (BPC)
25699	176-7555-xx	Base Processing Card (BPC) with 2 SPAM-HC
25698	176-7540-xx	Common RadioFrame Interface Card (CRIC)
24440	176-7562-xx	Ethernet Rear Transition Module (ERTM)
25700	176-0820-xx	Coaxial RMII Transceiver Card (CRTC)
25701	176-7502-xx	4U Chassis
25702	176-0600-xx	Power Distribution Unit (PDU)
25873	176-0810-xx	RF & Ethernet Cable Set (See NOTE)
25703	176-1219-xx	Fan Tray w/Fans for 4U Chassis
25704	176-0011-xx	Fan for RBS, RF Shelf, AIC & BIC
26757	176-0970-xx	Dual-Band RF Shelf (DBRFS)
26681	176-0860-xx	Multi-Channel RadioBlade (MCRB) Transceiver
26823	176-5000-xx	36-BR System Upgrade Kit
26394	176-0980-xx	Upgrade Kit for Single- to Dual-Band System
	176-1070-xx	Medium-Power RF Shelf
	176-0610-xx	Medium-Power PDU
	176-0014-xx	Medium-Power RFS Fan
	176-7010-xx	Upgrade Kit for Low-Power to Medium-Power System

Note: The cable set includes the following parts:
 111-0566-00 CABLE, ENHANCED CAT-5 BLACK PATCH, 7FT 1
 119-7000-00 PACKAGING KIT, PCA 1
 820-0001-05 ASY, CABLE, LMR-100A, SMA ST/RA, 6.5" 2
 820-0610-30 ASY, CABLE, LMR-195-PVC, SMA ST/N-TYPE, 51" 2
 820-0611-20 ASY, CABLE, LMR-195-PVC, SMA RA/RA, 92" 2
 820-0614-10 ASY, CABLE, POWER, AIC/BIC, 90" 1
 820-0616-50 ASY, CABLE, POWER, DC, M/M, 98" 1
 820-0620-00 ASY, CABLE, LMR-195-PVC, TYPE N/TYPEN, 84" 1

2 System Definition

The MC-Series Medium Power system is a stand-alone microcell base transceiver station (BTS) that provides radio communication links between the land network and mobile subscriber units in an integrated Dispatch Enhanced Network (iDEN). The MC-Series Medium Power system interfaces with the Mobile Switching Office (MSO) via a standard T1 interface. This link also provides the Operations and Maintenance Center (OMC) with alarm information, and enables the OMC to remotely control and configure system operations via a standard site datafill.

The MC-Series Medium Power system contains both RadioFrame Networks and non-RFN equipment enclosed in a single 19" equipment cabinet. The MC-15 MC-Series system is a three-sector configuration that supplies twelve full-duplex iDEN carriers per sector or up to 36 Base Radios (BRs) per site.

The MC-Series Dual band system is shipped ready to install and configure. The customer provides all non-RFN hardware except the EAS and 2 iSC3s, which come installed in the cabinet, T1 connectivity, datafill (network provisioning), antenna system, GPS (as required by iSC), electrical supply and the necessary permitting.

Figure 1 The MC-Series Dual-Band System Cabinet



2.1 MC-Series Medium Power System Configuration

The MC-Series Medium Power system can be configured to have 1, 2 or 3 sectors. The single sector configuration can have up to 12 BRs. In multi-sector configurations, up to 12 BRs may be assigned per sector, providing a maximum capacity of 36 BRs in a 3-sector configuration. As shipped, the MC-Series system is configured for 3 sectors. Configurations are summarized in Table 2.

Table 2 Sectorization and Maximum BR Allocation

Configuration	Max RF Carrier per Sector		
	Sector 1	Sector 2	Sector 3
One Sector Site	12	NA	NA
Two-Sector Site	12	12	NA
Three Sector Site	12	12	12

The MC-Series Medium Power system includes the following RadioFrame Networks hardware:

- BTS Interface Chassis (BIC) is the interface to the iSC and routes Ethernet traffic for up to three sectors.
- Airlink Interface Chassis (AIC) performs the digital receive and transmit function for each RadioBlade[®] transceiver and provides the common timing source for each RBS.
- RadioBlade Shelf (RBS) supports up to 36 RadioBlade transceivers.
- iDEN RadioBlade transceivers insert into slots in the RBS; each multi-channel RadioBlade (MCRB) transceiver corresponds to up to six iDEN carriers in the 800 or 900 MHz band, and each two-port RadioBlade (RBD2) transceiver corresponds to one iDEN carrier in the 800 MHz band.
- Dual-Band RF Shelf provides Rx-Tx amplification, filtering, and distribution between the RBS and external equipment.
- Power Distribution Unit (PDU) distributes DC power and provides overcurrent protection to each component in the MC-Series system cabinet.

The MC-Series system includes the following non-RadioFrame Networks hardware:

- iSC-3s: two integrated Site Controllers (iSC 3s) for redundancy
- Environmental Alarm System (EAS) provides additional external alarming as required

The MC-Series Dual-Band Medium-Power system requires the following non-RFN hardware to be installed at the site.

- Channel Service Unit (CSU) single-rack unit, high multi-purpose cross-connect, with the ability to aggregate multiple types of traffic onto a single T1 for backhaul to the MSO.
- DC power source.

Figure 2 MC-Series System 3-Sector Configuration

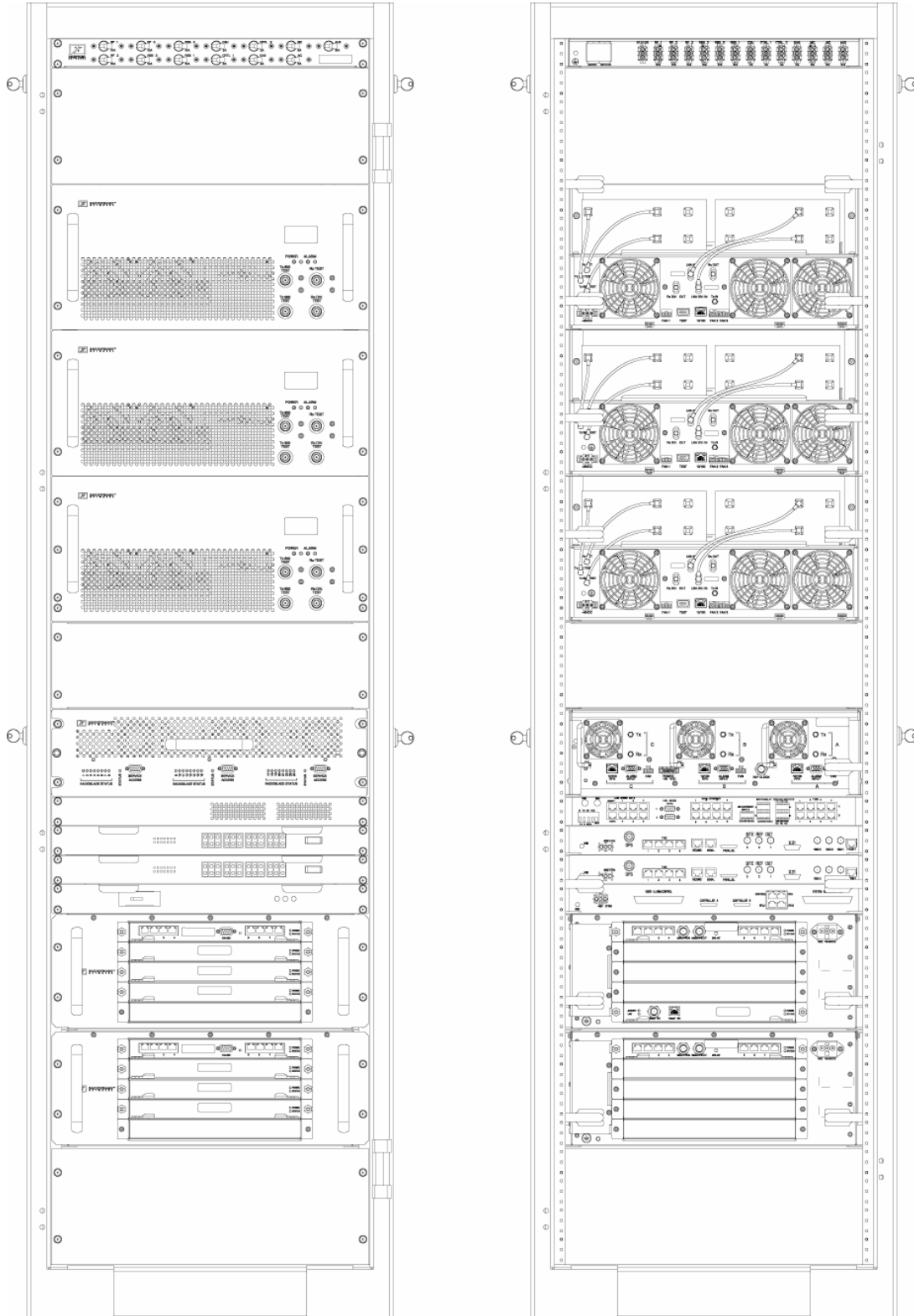

2.2 RadioFrame Networks Hardware

RadioFrame Networks hardware receives layer-3 control messages (control, voice, packet data, SNMP, etc.) from the iSC and converts them into layer 2 PDUs (Protocol Data Units) that are sent every 15 ms (received every 7.5 ms). Then the AIC converts the layer-2 PDUs into raw layer-1 Baseband I/Q samples that are sent/received every 7.5 ms.

Figure 3 MC-Series System Functional Diagram

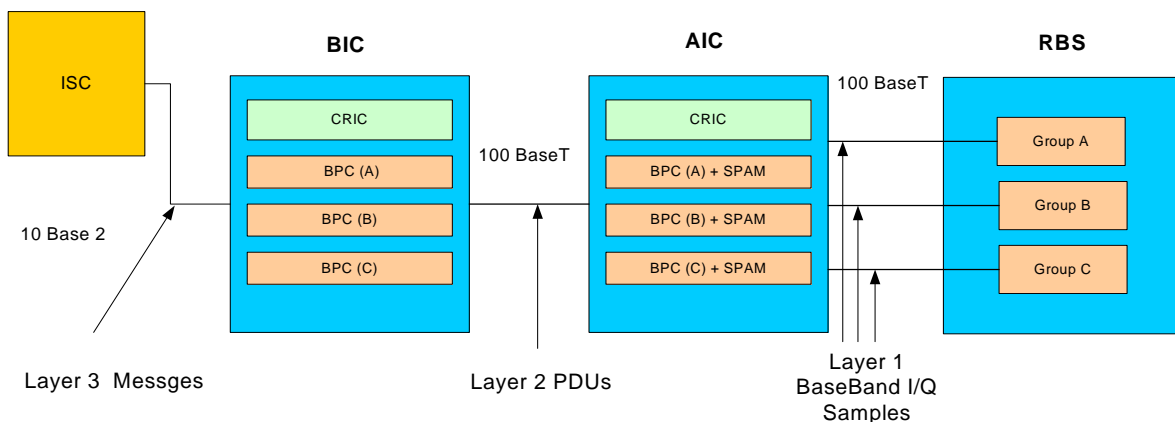

2.2.1 BTS Interface Chassis (BIC)

The BTS Interface Chassis (BIC) interfaces to the iSC and provides all Base Radio (BR) management functionality, including timing, converts iSC layer 3 messaging to layer 2 packets, and converts 1PPS 5 MHz clock to packet-delivered timing. Within the BIC chassis are four assemblies (see the following illustrations):

- BIC Common RadioFrame Interface Card (CRIC)
- BTS Processing Card (BPC)—up to three BPCs per system, one BPC per sector, deployed in front slots 2, 3 and 4
- Ethernet Rear Transition Module (ERTM)
- Coax-to-RMII Transceiver Card (CRTC) (2) deployed in rear slots 3 and 5

Figure 4 BIC Front View

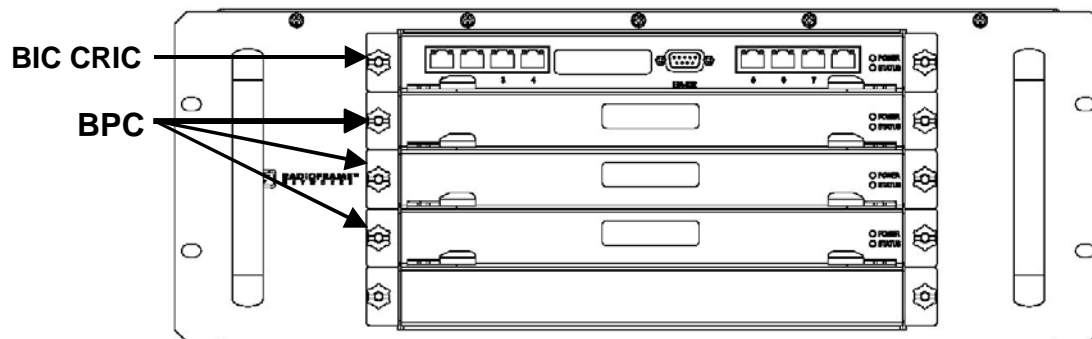
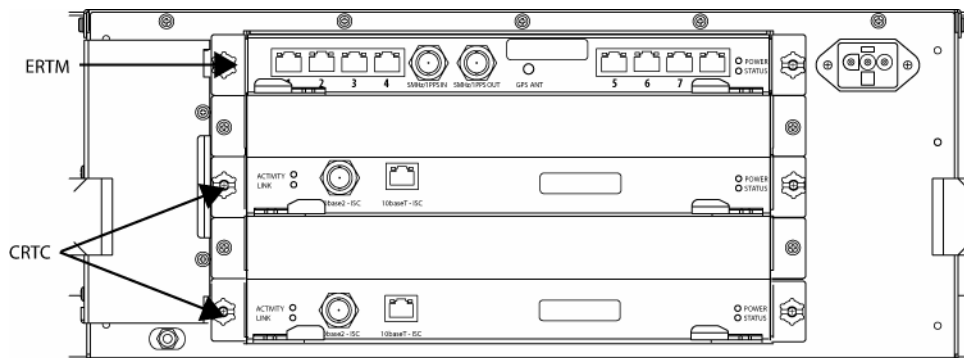

Figure 5 BIC Rear View, Showing Optional 2nd CRTC in the Third Slot



2.2.1.1 BIC CRIC

The BIC Common RadioFrame Interface Card (CRIC) is located in the top front slot of the BIC. The BIC CRIC provides the Ethernet switch fabric to route packets to/from the AIC and hosts a microprocessor that serves as the primary controller of BPCs for system-management purposes. The BIC CRIC has a serial port for local serial access, and eight 10/100BaseT Ethernet ports. Currently, ports 1 through 7 are not used; only port 8 is available for local technician Ethernet access.

Figure 6 BIC CRIC Ports and Indicators

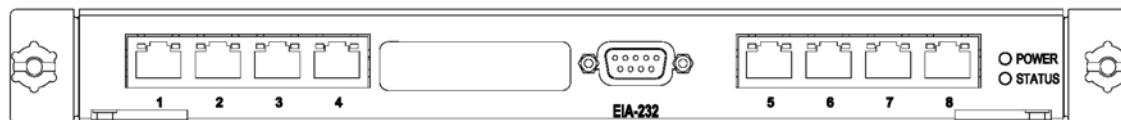

2.2.1.2 BPC

Three BTS Processing Cards (BPCs) are located in BIC front-slot positions 2, 3 and 4. The BPC hosts a microprocessor to perform iDEN voice management and is responsible for layer-2 call processing.

Figure 7 BPC indicators



2.2.1.3 ERTM

The Ethernet Rear Transition Module (ERTM) is located in the top rear slot of the BIC. The ERTM interfaces to the CRIC via eight RMII ports in the chassis midplane. The ERTM provides Ethernet connectivity between the BIC and AIC as well as a connection to the CRTC.

Note: The current-revision ERTM is used in either the AIC or BIC and is configured by means of an internal switch. Some BICs are equipped with a BIC-only ERTM, identified on the faceplate: “ERTM ASY-0562-XX”, where XX ≤ 05. The version that works in either the AIC or BIC is labeled “-06” or later.

Figure 8 ERTM Ports and Indicators

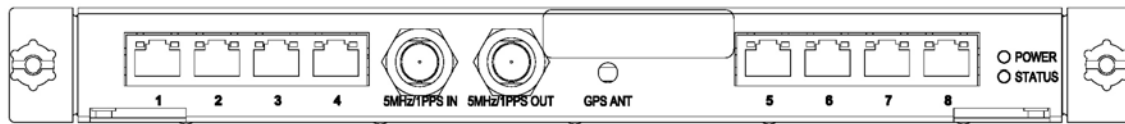

2.2.1.4 CRTC

The Coax-to-RMII Transceiver Cards (CRTCs) is located in the bottom rear slots of the BIC. A second optional CTRC is needed for 24 or more RadioBlade transceivers and in some other configurations. If present, this second CTRC resides in the 3rd slot. The CRTC provides conversion of the 10Base2 connection at the iSC to a 10BaseT connection in the BIC.

Figure 9 CRTC Ports and Indicators



2.2.1.5 BIC Ports

Table 3 Ports in the BIC

Card	Port	Description
Front		
BIC CRIC	Ports 1-7 (RJ-45)	not currently used
	Port 8 (RJ-45)	Sprint Nextel technician local Ethernet access
	EIA-232 9-pin serial port	Sprint Nextel technician local serial access
BPC	N/A	N/A
Back		
ERTM	Port 1 (RJ-45)	CRTC 1 Port 10BaseT
	Port 2 (RJ-45)	AIC ERTM port 4
	Port 3 (RJ-45)	CRTC 2 Port 10BaseT (Optional)
	Port 4 (RJ-45)	not currently used
	Port 5 (RJ-45)	RF Shelf 1 10/100 Port 1
	Port 6 (RJ-45)	RF Shelf 2 10/100 Port 1
	Port 7 (RJ-45)	RF Shelf 3 10/100 Port 1
	Port 8 (RJ-45)	Remote Ethernet connectivity (DNX-1u Ethernet)
	5 MHz/1PPS IN	iSC-3 5-MHz/1PPS port
	5 MHz/1PPS OUT	not currently used (no terminator required)
GPS ANT	not currently used	
CRTC 1	10Base2 – iSC	ISC-3 10Base2 port
	10BaseT – iSC	BIC ERTM port 1
CRTC 2	10Base2 – iSC	ISC-3 10Base2 port

(Optional)	10BaseT – iSC	BIC ERTM port 1
------------	---------------	-----------------

2.2.1.6 BIC Indicators

Each card installed in the BIC has a **Power** LED and a **Status** LED that indicates timing synchronization.

Note: The CRIC Status LED represents PLL status. The system will not go active unless this LED is green.

Each RJ-45 port has an Ethernet **link** LED that indicates connectivity and an Ethernet **activity** LED that indicates Ethernet traffic (Figure 10).

Figure 10 BIC RJ-45 Port Indicators

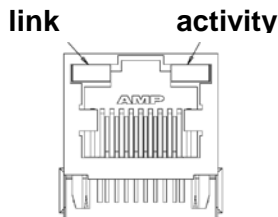

2.2.2 Airlink Interface Chassis (AIC)

The Airlink Interface Chassis (AIC) provides layer-1 and layer-2 processing of call data, including routing of packet data to RadioBlade transceivers in RBS, as well as timing to the RBS. Within the AIC chassis are three assemblies:

- AIC Common RadioFrame Interface Card (CRIC)
- BTS Processing Card + Signal Processing Array Module (BPC+SPAM)—three BPC+SPAM per AIC in front slots 2, 3 and 4
- Ethernet Rear Transition Module (ERTM)

Figure 11 AIC Front View

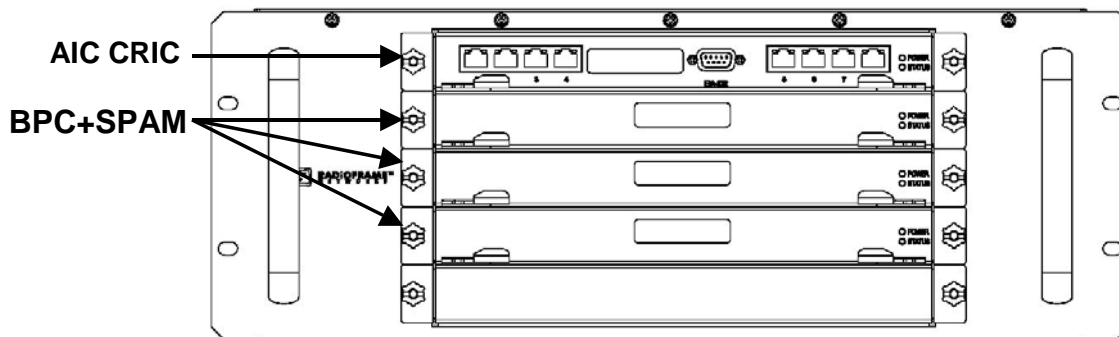
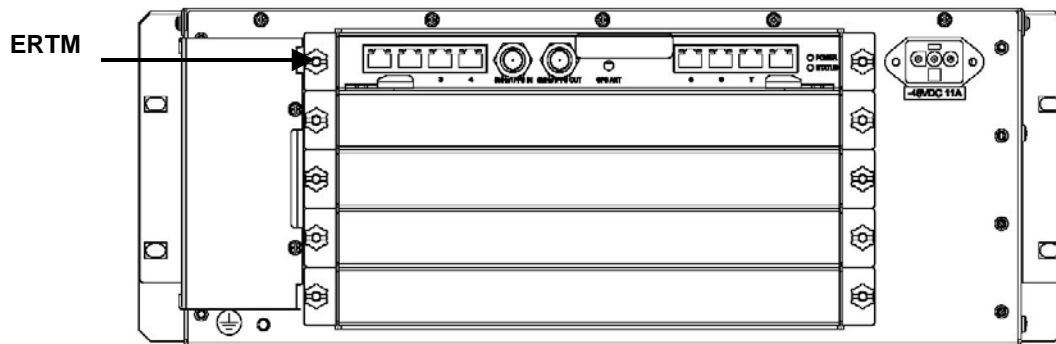

Figure 12 AIC Rear View



2.2.2.1 AIC CRIC

The AIC Common RadioFrame Interface Card (CRIC) provides the Ethernet switch fabric to route packets to/from the RBS. The AIC CRIC hosts a microprocessor as the primary controller of BPC+SPAMs. The AIC CRIC has a serial port for local serial access, and eight 10/100BaseT Ethernet ports that are currently not used.

Figure 13 AIC CRIC Ports and Indicators

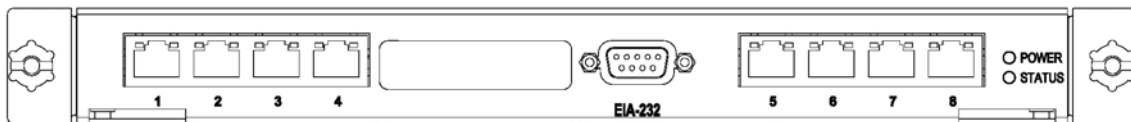

2.2.2.2 BPC+SPAM

BTS Processing Card + Signal Processing Array Module (BPC+SPAMs) are DSP modules that control the transfer of voice I/Q samples to/from the RBS. BPC+SPAMs perform all necessary functions of radio link formatting, coding, timing, error control and framing: Voice Control Procedure (VCP), Associated Control Procedure (ACP), Slot Interchange Procedure (SIP) and Random Access Protocol (RAP).

Figure 14 BPC+SPAM Indicators



2.2.2.3 ERTM

The Ethernet Rear Transition Module (ERTM), located in a rear slot of the AIC, interfaces to the CRIC via eight RMII ports in the chassis midplane. The ERTM provides Ethernet connectivity between the AIC and RBS.

Figure 15 ERTM Ports and Indicators

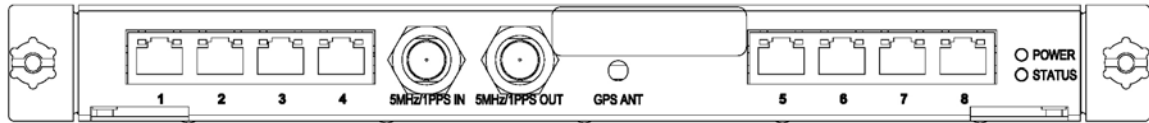

2.2.2.4 AIC Ports

Table 4 Ports in the AIC

Card	Port	Description
Front		
AIC CRIC	Ports 1-8 (RJ-45)	not currently used
	EIA-232 9-pin serial port	Sprint Nextel technician local serial access
BPC+SPAM	N/A	N/A
Back		
ERTM	Ports 1-3 (RJ-45)	RBS port 10/100 RFN A, B and C respectively
	Port 4 (RJ-45)	BIC ERTM port 2
	5 MHz / 1PPS IN	not currently used (no terminator required)
	5 MHz / 1PPS OUT	not currently used (no terminator required)
	GPS ANT	not currently used

2.2.2.5 AIC Indicators

Each card installed in the AIC has a **Power** LED and a **Status** LED that indicates timing synchronization.

Each RJ-45 port has an Ethernet **link** LED that indicates connectivity and an Ethernet **activity** LED that indicates Ethernet traffic (Figure 16).

Figure 16 AIC RJ-45 Port Indicators

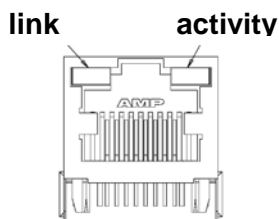

2.2.3 RadioBlade Shelf (RBS)

The RadioBlade Shelf (RBS) houses the iDEN 2-port RadioBlade transceivers, the RadioBlade transceiver “backplane” and RF combiner and splitter assemblies. The whole assembly is housed in a pullout shelf to facilitate field replacement of the RadioBlade transceivers.

The RBS is divided logically into three sets of eight slots. Each set of slots is referred to as a group—A, B and C—numbered from left to right when facing the front of the unit. The groups share redundant DC-DC converters. The slot connectors on the RBS provide

the control and data interface to each RadioBlade transceiver. Each group interfaces with the AIC via a separate 100BaseT Ethernet connection. In addition, a serial console port and status LEDs for each group are routed to the front panel of the RBS.

RF combining is also accomplished on a per group basis. Integrated into the RBS are 1:8 power splitters for the Rx path and 8:1 power combiners for the Tx path.

Figure 17 RBS Group Functional Diagram

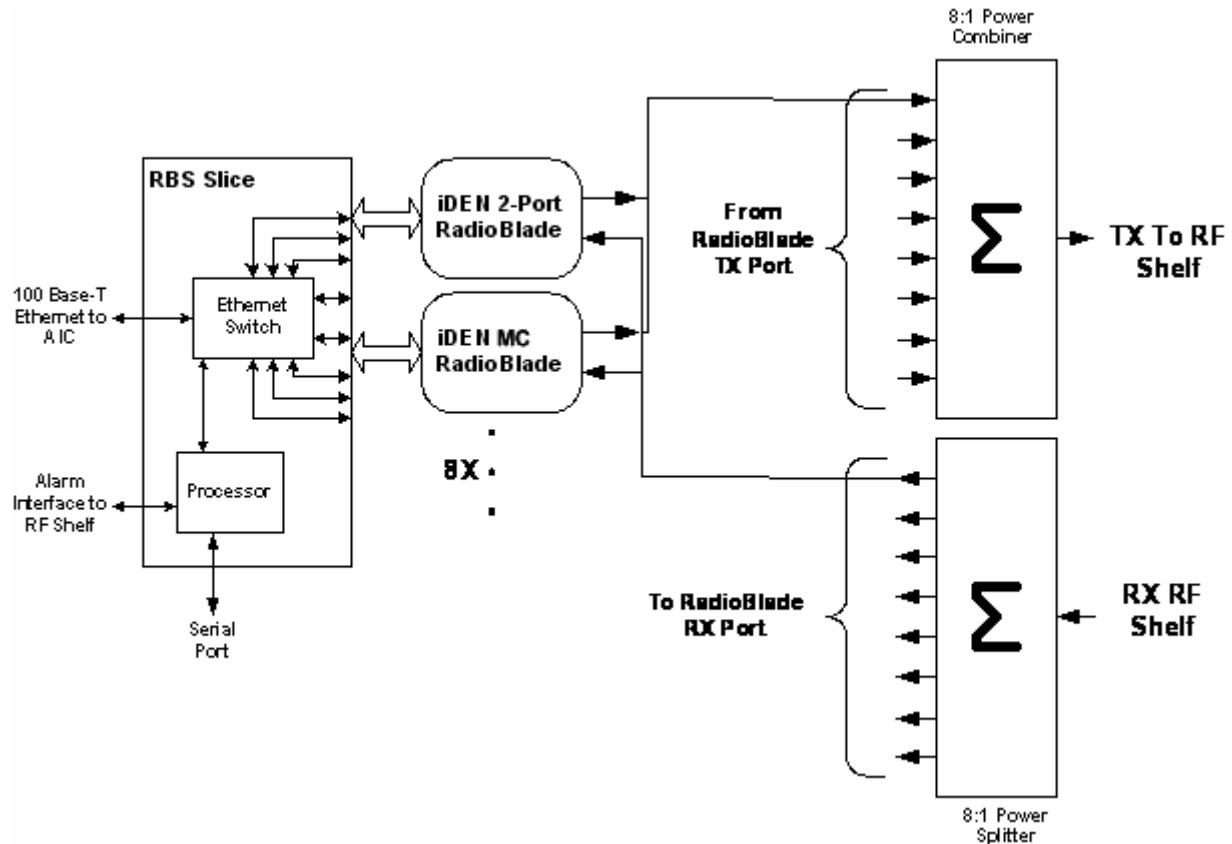

Figure 18 RBS Interior, Top Down View

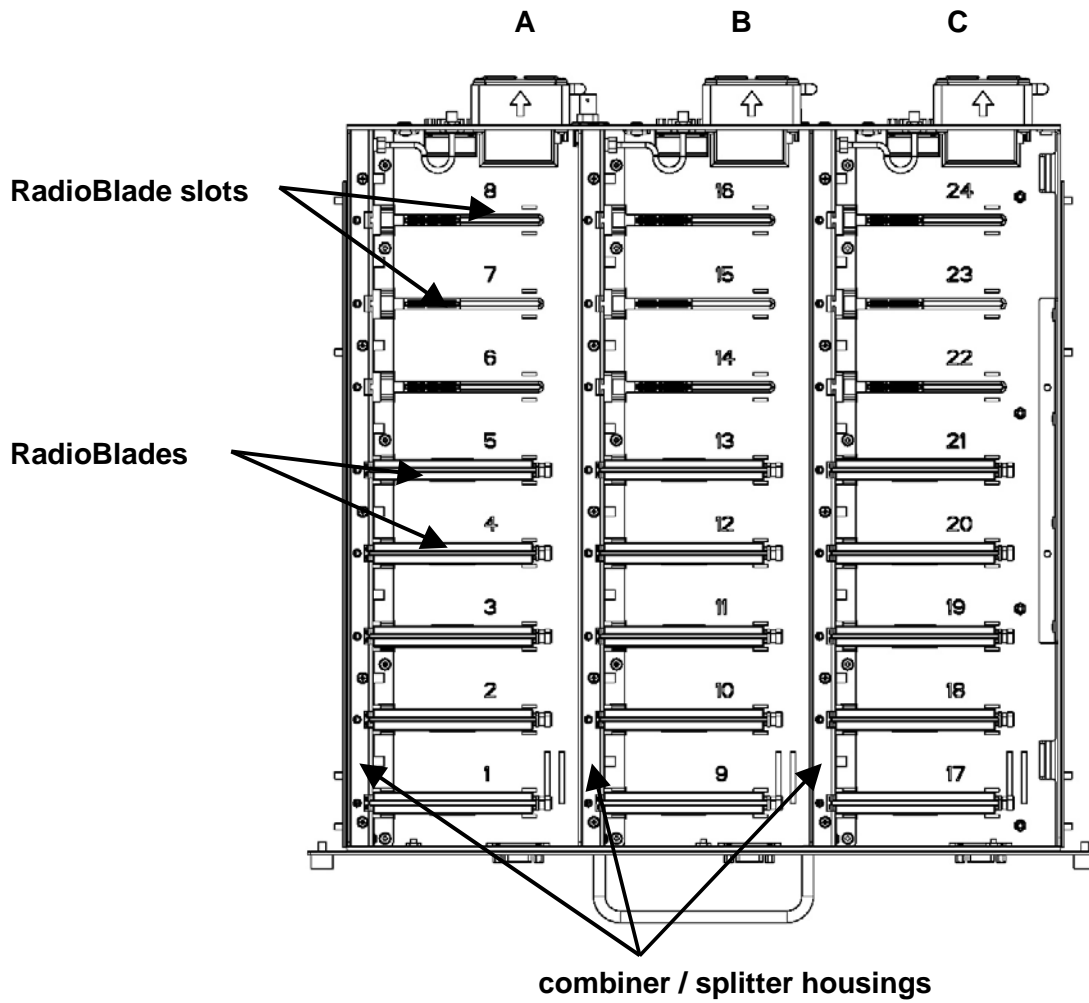

Figure 19 RBS Front View

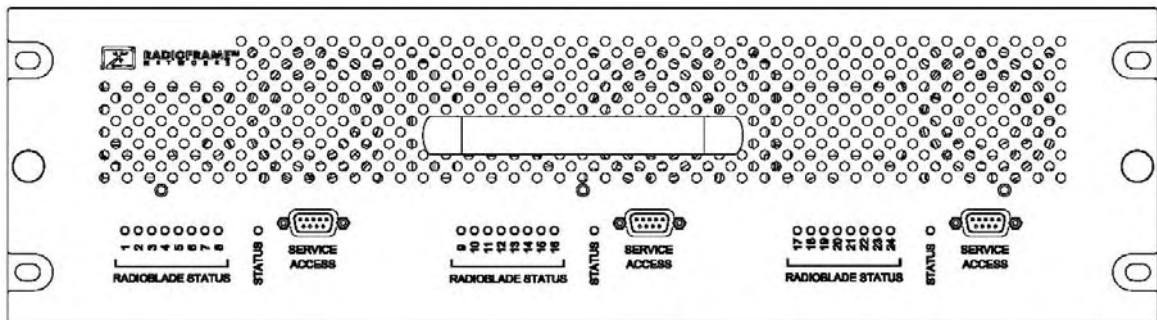
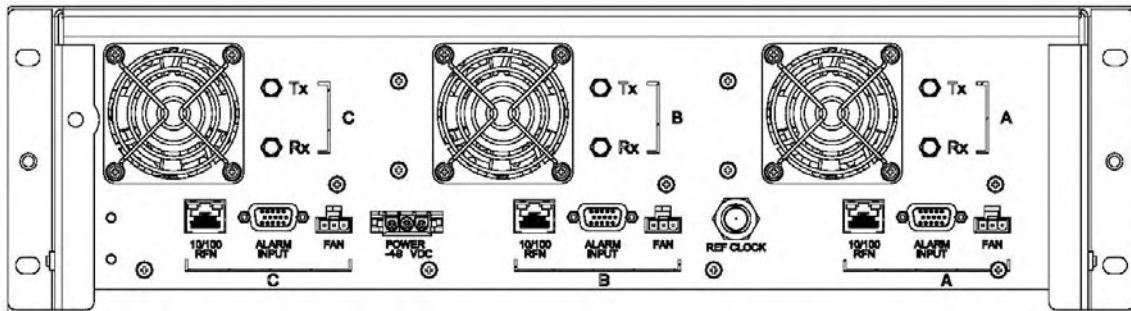

Figure 20 RBS Rear View



2.2.3.1 RBS Ports

Table 5 RBS Ports

Ports	Description
Front Ports	
SERVICE ACCESS (A, B, C)	Sprint Nextel technician local serial access
Rear Ports	
Tx / Rx (A, B, C)	Input and output for RF Shelf (wiring depends on system configuration)
Fan (A, B, C)	Power connector
ALARM INPUT (A, B, C)	ALARM serial port on the back of RF Shelf 1, RF Shelf 2, and RF Shelf 3 (respectively); THESE PORTS ARE NOT USED WITH MCMP SYSTEM
10/100 RFN (A, B, C)	100Base-T Ethernet from AIC ERTM Ethernet ports 1, 2 and 3 (respectively)
REF CLOCK	not currently used

2.2.3.2 RBS Indicators

The front of the RBS has the following LED indicators:

- **STATUS** indicator for each group—A, B and C
- **RADIOBLADE TRANSCEIVER STATUS** indicators, one for each RadioBlade transceiver slot in the RBS. LEDs are arranged by group (8 per group A, B and C) and are numbered consecutively from left to right 1 through 24 (A: 1 through 7; B: 8 through 16; and C: 17 through 24).

Each RJ-45 port (rear only) has an Ethernet **link** LED that indicates connectivity and an Ethernet **activity** LED that indicates Ethernet traffic.

Table 6 RBS Indicator LEDs

LED	Indication
STATUS	Indicates timing synchronization for group
RADIOBLADE TRANSCIVER STATUS	Indicates status of RadioBlade: green = operational; red = alarm condition; not lit = RadioBlade not present

2.2.4 iDEN RadioBlade Transceivers

Each iDEN two-port RadioBlade® (RBD2) transceiver is equivalent to a Motorola Base Radio. Each multi-channel RadioBlade (MCRB) transceiver corresponds to up to six iDEN carriers in the 800 or 900 MHz band. Both types of RadioBlade transceiver look similar to Figure 21. Each has an edge connector to interface with the slot connector in the RBS. This edge connector provides all data interfaces and clock inputs to the RadioBlade transceiver. The RF interface employs two SMA connectors, one for transmit and the other for receive. The MCRB is distinguished by the notations on the label shown in Figure 22.

Figure 21 iDEN 2-Port RadioBlade Transceiver

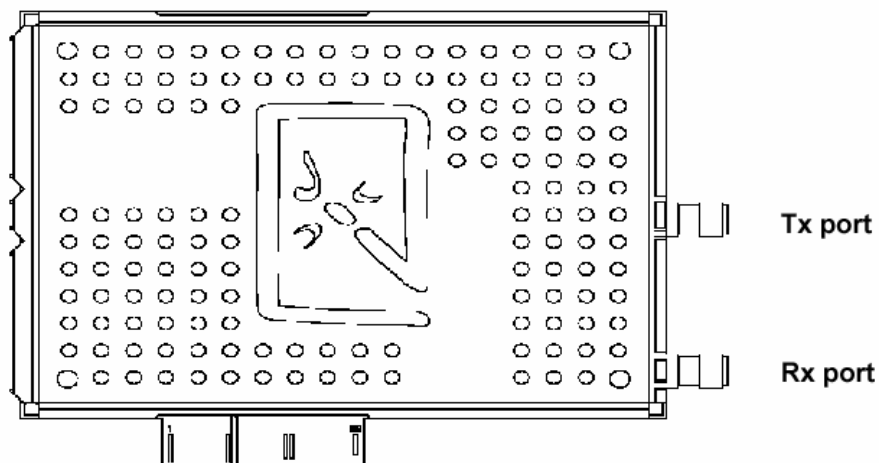

2.2.4.1 800 MHz RadioBlade Transceivers

Up to 36 RadioBlade transceivers are installed into the RadioBlade Shelf.

2.2.4.2 Multi-Channel RadioBlade Transceivers

The MCRB duplicates the RF functions of up to 6 simultaneously operational iDEN radio transceivers, supporting six corresponding Transmit (Tx) – Receive (Rx) channel pairs with full-duplex operation. The MCRB can operate in either the 800E or the 900 MHz band as configured by system software.

Figure 22 MCRB Label Position

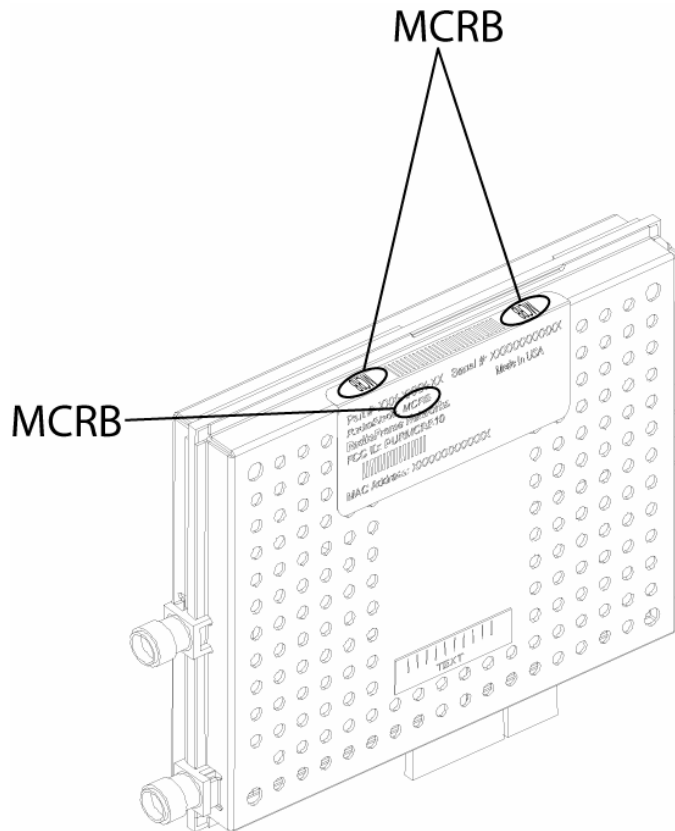

2.2.4.3 Combined RadioBlade Transceivers in an RBS

The MCRB allows up to 6 BRs to be assigned to a single physical RadioBlade transceiver with a requirement applied that all carriers need to be within the same 1.25 MHz band. Because of this requirement, all frequencies need to be known prior to the programming of the MCRB. To accommodate this, all BRs set up in the iDEN configuration page will register with the network to get assigned frequencies. Once the frequencies are known, and the available HW resources are known, the carriers are assigned to the MCRBs and single-channel RadioBlade transceivers by the following rules:

- 1) Any 900 MHz BRs will be assigned to an MCRB.
- 2) The largest group of carriers which fall within the 1.25 MHz band is assigned to the MCRB if one is available. (Note: This process repeats until there are no remaining unassigned MCRBs.)
- 3) Any carriers that remain unassigned are assigned to single-channel RadioBlade transceivers.
- 4) If any carriers are still unassigned, an alarm is sent to the OMC.
- 5) If any MCRBs or single-channel RadioBlade transceivers are unassigned, they become standby blades.

2.2.5 Medium Power Dual-Band RF Shelf

The MC-Series system provides one RF shelf per sector. The RF shelf contains amplifiers, filters, combiners, redundant DC-DC converters and fans to provide cooling to the power amplifiers (PAs).

The transmit chain includes a software-controlled variable attenuator for adjusting the Tx power output at the top of the cabinet, a multi-channel linear power amplifier (PA), a band

pass filter and a sampling port. The Tx sampling port provides approximately top of the rack (TOR) minus 20 dB output power. The Tx power output at the top of the rack can be varied by changing the datafill.

The PA is sized to allow sufficient linearity and gain such that a minimum of +29 dBm per carrier (up to 12 carriers) can be achieved at the top of the rack. The sampling port signal is brought out to the front of the RF shelf to provide monitoring and testing of the transmit path.

The receive path contains a band pass filter, low noise amplifier (LNA) and a sampling port. As with the Tx sampling port, the Rx sampling port is brought out to the front panel of the RF shelf. The Rx sampling port provides approximately top of the rack (TOR) minus 20 dB output power.

Figure 23 Dual-Band Medium Power RF Shelf Functional Diagram

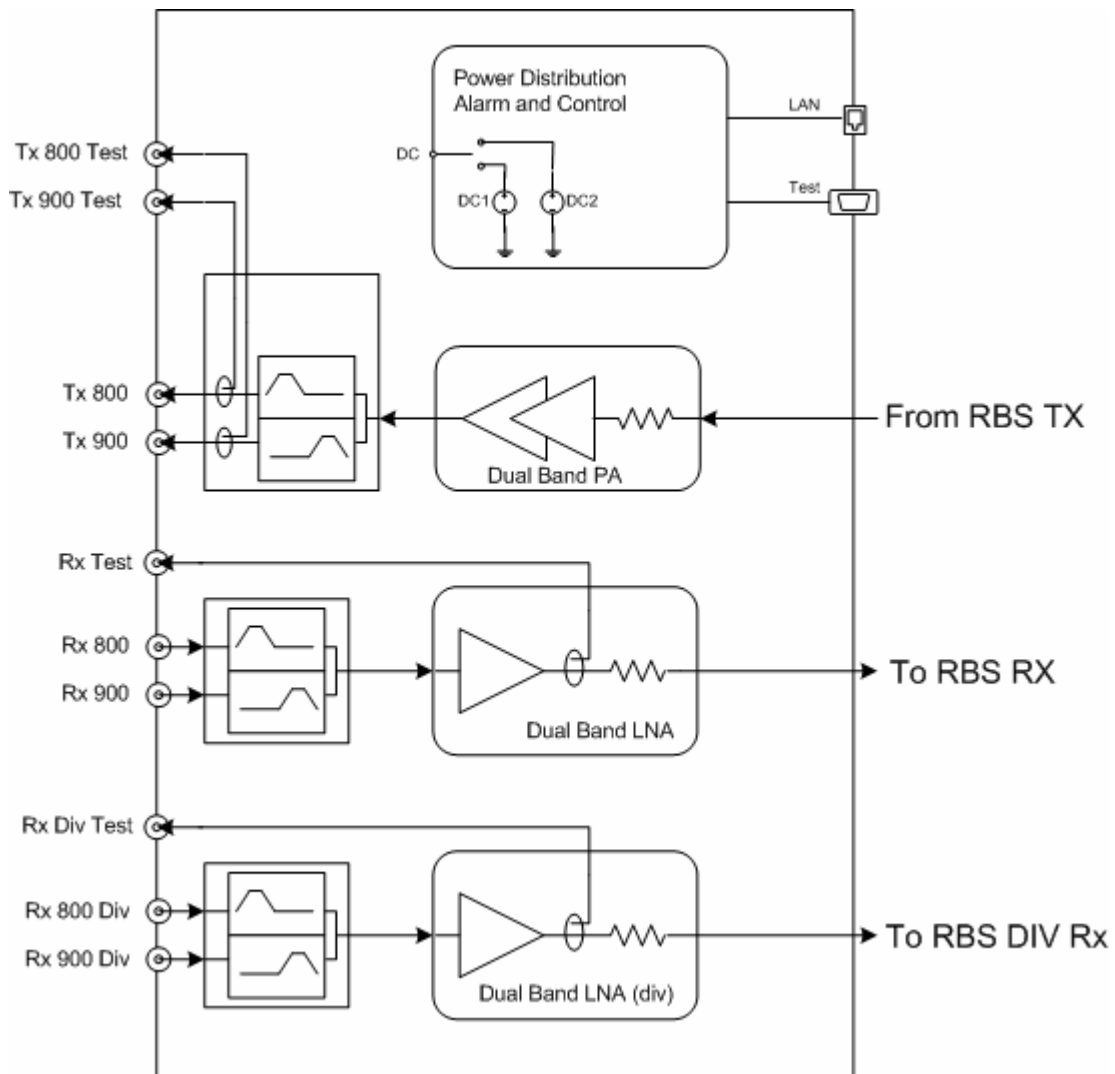

Figure 24 Dual-Band Medium-Power RF Shelf Front View

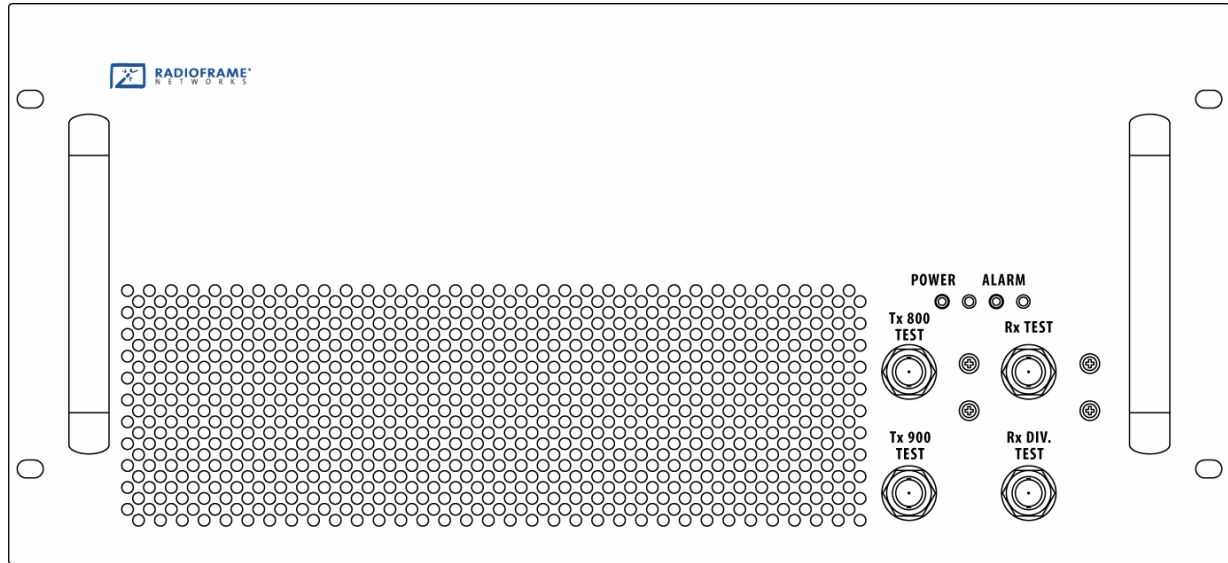
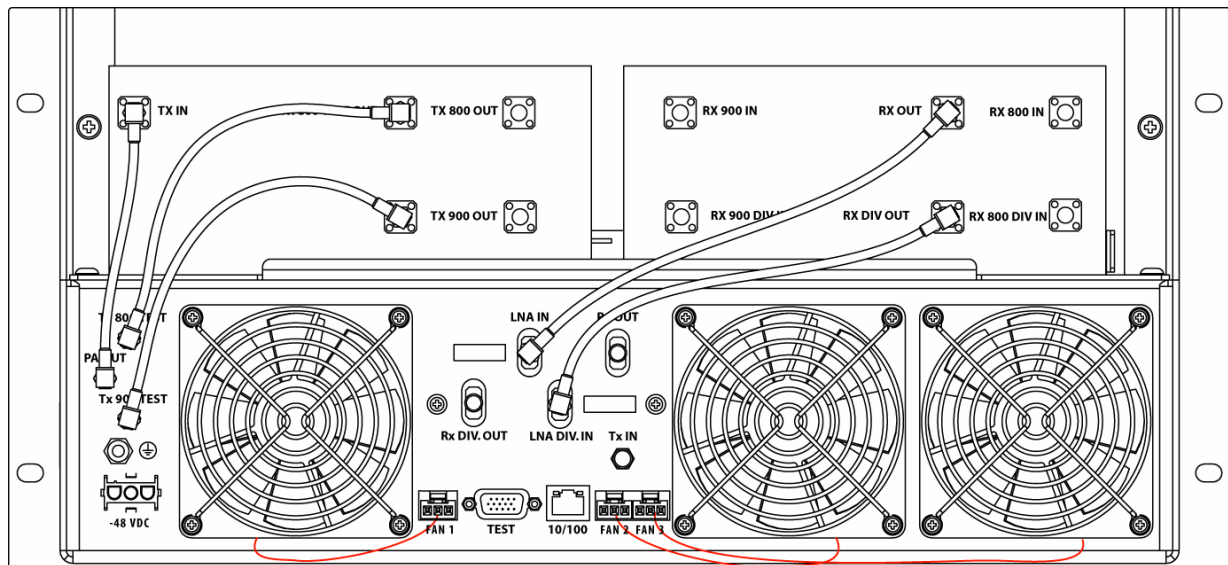

Figure 25 Dual-Band Medium-Power RF Shelf Rear View



2.2.6 Power Distribution Unit

The Power Distribution Unit (PDU) receives DC input and supplies power via dedicated circuit breakers to each component in the MC-Series Medium-Power System. Each of the thirteen breakers has a three-position switch: ON, OFF or TRIPPED. The single alarm output connected to each breaker is normally closed, and goes open when a breaker is tripped.

Table 7 PDU Circuit Breaker Overview

Breaker Amps	Quantity
15	3
10	4
6	2
3	4

Figure 26 PDU Front View

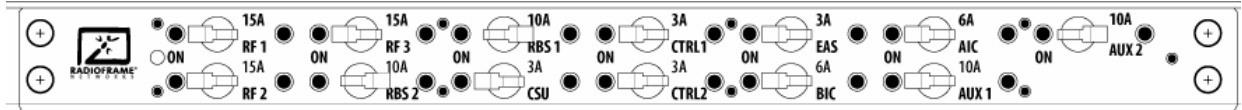
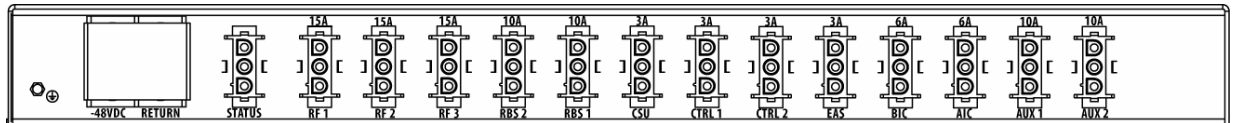

Figure 27 PDU Rear View



2.2.7 Cabinet

The MC-Series Medium Power system cabinet is a standard 19" equipment cabinet with vented, lockable side panels, vented lockable front and rear doors and a computer shelf on the inside of the front door. The cabinet is rated for seismic zone 4 and operates in an environment of 0° to +40° C ambient. External RF connectors are flush with the top of the cabinet in a recessed bulkhead. For more information, refer to the cabinet manufacturer's documentation shipped with the MC-Series system.

2.3 System Manager Software

The MC-Series Medium Power system is managed and configured via RadioFrame Networks System Manager, a Web-based graphical management system, which is accessible via any IP-based connection. System Manager provides Operations personnel with remote access and control, including configuration, alarm monitoring, triage/troubleshooting and system statistical reporting. All RFN MC-Series systems include System Manager as standard equipment. Core System Manager functions include:

- Software download (both locally and remotely)
- Status & Configuration screens
- Local & remote software upgrade—concurrent distribution of software upgrades across all network elements (via script)
- Configuration management
- System parameters display
- System performance statistics
- Diagnostics and troubleshooting
- Voice loopback
- Administrative Lock/Unlock of Carriers/BRs

- Real time Alarm Manager with X.733 Alarming
- Call Statistics and Uptime
- RF Performance Metrics (e.g., Uplink SQE, Noise Floor, etc.)
- Test and Maintenance (e.g., automated BER testing)

Figure 28 System Manager Main Page



2.4 Non-RFN Hardware

Non-RFN hardware for the MC-Series system must be procured and then installed in order for the MC-Series system to be complete.

2.4.1 integrated Site Controller (iSC-3) (comes pre-installed)

The MC-Series system includes a pair of redundant integrated Site Controllers, or iSC-3s, which are connected to the macro network through a Channel Service Unit (CSU). The connection between the iSC and the MC-Series system is via two coaxial interfaces. The first is a 10Base2 Ethernet connection to provide data communications. This connection is made directly to the MC-Series system and does not require an external media converter. The second connection is a 1PPS reference for system timing.

For more information about the iSC-3, refer to the Motorola document *Gen 3 Site Controller System Manual*, 68P80801E30-O.

2.4.2 Environmental Alarm System (EAS) (comes pre-installed)

The Environmental Alarm System (EAS) provides a central location for site alarm signal processing. The EAS monitors site environmental conditions, including AC power, smoke alarms, intrusion alarms, antenna tower lights, etc.

Each of the site alarm contacts are normally closed and connected to the EAS through a 50-pin Champ cable that connects to a punch block. All alarm contact pairs must be dry

(isolated from ground). Most alarm connections are inputs. Outputs provide a dry relay closure rated at 0.5 A, 30 Vrms or 60 VDC, 10 VA max.

Plan to implement EAS alarm blocks, wiring and sensors as required depending on the installation:

- If the MC-Series system cabinet is deployed as a standalone unit (i.e., as the only cabinet in the area), plan to provide standard Sprint Nextel facility environmental sensors, wiring, and connections. Plan to install the EAS alarm blocks on the Telco board on the wall of the space where the MC-Series system cabinet is located, and locate the high-temperature and low-temperature sensors there. Plan to provide conduit or other wire routing from a door sensor, HVAC units (if separate HVAC units are installed for the installation), and AC power failure / surge arrestor failure sensors.
- If the MC-Series system cabinet is deployed as one of a group of cabinets (i.e., in an RF “hotel”), plan to provide standard Sprint Nextel facility environmental sensors, wiring and connections for one of the cabinets. The alarm facilities for the other cabinets will generally not be used. For the cabinets with unused alarms, plan to strap all alarm inputs with 24 AWG solid-conductor wire (e.g., wire from a Category 5 cable). Plan to extend the 25-pair alarm cables with pre-connectorized 25-pair extension cables as needed to allow the alarm blocks to reach the wall space where they are to be mounted. *Do not* plan to leave the alarm blocks in the cabinets or otherwise not mounted.

If the alarm block must be installed within the MC-Series cabinet, mount as shown in Figure 29.

For more information about the EAS, refer to the Motorola document *Gen 3 Site Controller System Manual*, 68P80801E30-O.

Figure 29 Punch Block Location within the MC-Series Rack

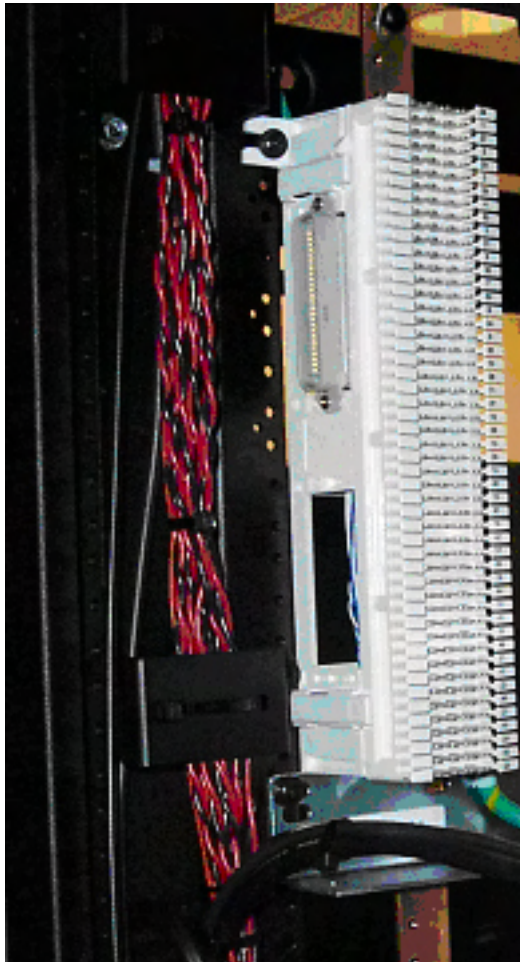

2.4.3 Channel Service Unit (CSU) (must be installed)

The Channel Service Unit (CSU) provides the T1 connection between the iSC-3 and the telephone company that provides the T1 line. The CSU provides surge protection to the T1 line and loop-back testing for the telephone company.

For more information about the CSU, refer to the manufacturer's documentation.

2.4.4 GPS Antenna System (must be installed)

The Global Positioning System (GPS) antenna provides GPS signals to the iSC-3, which constructs the timing reference for the MC-Series system hardware. One GPS antenna with a dedicated 50 Ω coax cable is required for each iSC-3.

2.4.5 Powerplant (must be installed)

The MC-Series system cabinet is powered by a nominal -48 VDC powerplant supplied by the customer. The powerplant may be installed in the cabinet or used externally. The cabinet is shipped with a Power Distribution Unit (PDU) installed in the cabinet. The PDU contains circuit breakers that provide overcurrent protection for MC-Series loads.

2.5 Specifications

2.5.1 Dimensions

Table 8 Dimensions

Supplier	Component	Equipment Dimensions			
		Width	Depth	Height	
RadioFrame Networks	cabinet	23.5"	25.5"	79"	42U
	BIC	19"	13"	7"	4U
	AIC	19"	13"	7"	4U
	RBS	19"	13"	7"	4U
	Dual-Band Medium Power RF Shelf	19"	13"	8.75"	5U
	PDU	19"	10"	1.75"	1U
Non-RFN	iSC-3	19"	9"	1.75"	1U
	EAS	19"	15"	1.75"	1U
	CSU	19"	12.5"	1.75"	1U

2.5.2 Weight

Table 9 Weight

Supplier	Component	Weight
RadioFrame Networks	cabinet	730 lbs (shipped) 692 lbs (fully loaded)
	BIC	22 lbs
	AIC	22 lbs
	RBS	60 lbs (24 RadioBlade transceivers)
	Dual-Band Medium Power RF Shelf	168 lbs (56 lbs each)
	PDU	10 lbs
Non-RFN	iSC-3	16 lbs (8 lbs each)
	EAS	6 lbs
	CSU	10 lbs

2.5.3 Floor Loading

Table 10 Floor Loading

Supplier	Component	Floor Loading
RadioFrame Networks	cabinet	200 lbs per sq ft (includes a safety factor)

2.5.4 Power Requirements

Table 11 Power Requirements

Supplier	Component	Power
RadioFrame Networks	BIC	-42 to -56 VDC
	AIC	-42 to -56 VDC
	RBS	-42 to -56 VDC
	RF Shelf	-42 to -56 VDC
	PDU	-42 to -56 VDC
Non-RFN	iSC-3	-40 to -60 VDC
	EAS	-40 to -60 VDC
	CSU	-40 to -60 VDC

2.5.5 Power Consumption

Table 12 Power Consumption per Assembly (See Note)

Assembly	Qty	Power per Assembly (W)	Total Power (W)	Current (A @ -48 VDC)
RF Shelf	3	532.7	1305.6	29.2
RBS (24 RadioBlade transceivers)	1	67.2	67.2	1.4
BIC	1	110.0	110.0	2.3
AIC	1	115.2	115.2	2.4
ISC	2	24.0	48.0	1.0
EAS	1	19.2	19.2	0.4
CSU	1	40.0	40.0	0.8
		TOTAL	1705	35.5

Note: Panduit termination lugs are required for installation. Wire size is AWG 6.

2.5.6 Grounding

Table 13 Grounding Resistance at Cabinet (TOR)(See Note)

Supplier	Component	Ground Resistance (Ω)
RadioFrame Networks	cabinet	0.6

Note: Panduit termination lugs are required for installation. Wire size is AWG 6.

2.5.7 Heat Load

Table 14 Heat Load

Supplier	Component	Heat Load (BTUs per Hour)
RadioFrame Networks	BIC	340
	AIC	340

	RBS	320
	RF Shelf	TBD
	PDU	10
Non-RFN	iSC-3	140
	EAS	170
	CSU	140
	TOTAL	

2.5.8 RF Performance

The MC-Series system will meet the emissions mask requirements per FCC Part 90, section 90.691.

2.5.8.1 Operating Frequency Bands

Table 15 Transmit and Receive Frequencies

Band	Receive Frequency (MHz)	Transmit Frequency (MHz)
800E	806.0125 to 823.9875	851.0125 to 868.9875
900	896.01875 to 900.98125	935.01875 to 939.98125

2.5.8.2 Transmitter Performance Summary

Table 16 Transmitter Performance Summary

Parameter	Condition (Note 1)	Value			Unit
		Min	Typ	Max	
Tx Output Power Level (Note 2)	OMC Datafill: DefaultTxPower = 9.5	+27	+29	+31	dBm
Tx Output Power Control Range		+18	--	+29	dBm
Transmit port VSWR	Referenced to a 50 Ω impedance	--	--	2:1	--
Downlink Signal Quality Estimator (SQE)	Average value	--	30	--	dB
Occupied bandwidth	Per carrier	--	18.5	--	kHz
RF Frequency Tolerance (Tx)	Average frequency	--	--	± 50	Hz

Note 1: Unless otherwise stated, all values are referenced to the top of the rack.

Note 2: At maximum rated RF output power, all spurious and harmonic emissions should be at the noise floor. No combination of IM products or any other spurious emissions generated in the transmitting equipment should exceed the underlying noise floor in the operating band. Also, the Tx output power level is a function of the datafill parameters. The nominal maximum Tx power at the top of the rack with a maximum variation of ± 2 dB is +29 dBm.

2.5.8.3 Tx Power Out

The transmit power out at the top of the rack (TOR) is dependent on the iSC datafill. Table 17 displays defaultTxPower vs. TOR output Power. The dynamic range is 11 dB,

but the output power has been shifted up considerably from the low-power MC-Series system.

Table 17 TOR Output Power

defaultTxPower	TOR Tx Output (dBm)
8.4	+18
8.5	+19
8.6	+20
8.7	+21
8.8	+22
8.9	+23
9.0	+24
9.1	+25
9.2	+26
9.3	+27
9.4	+28
9.5	+29

2.5.8.4 Receiver Performance Summary

Table 18 Receiver Performance Summary

Parameter	Condition (NOTE 1)	Value			Unit
		Min	Typ	Max	
Rx Input Level	2% BER	-106	--	-40	dBm
	Absolute Maximum where no damage occurs	--	--	+10	dBm
Residual BER	Input signal of -80 dBm	--	--	0.1	%
Input IP3	Single channel input	+10	--	--	dBm

Note 1: Unless otherwise stated, all values are referenced to the top of the rack.

2.5.8.5 Spurious RF Emissions

The MC-Series iDEN Microcell system will meet the emissions mask requirements per FCC Part 90, section 90.691.

2.5.9 Environmental Specifications

Table 19 Environmental Specifications

Parameter	Condition	Value			Unit
		Min	Typ	Max	
Ambient Temperature	Normal operation	0	27	40	°C
	Storage	-40		+70	°C
Humidity	Normal operation relative, non-condensing	10		90	%
	Storage, non-condensing	5		90	%
Altitude	Relative to mean sea level.	-60		1800	m
Shock		40			G
Vibration	Level 4 earthquake; meets or exceeds GR-63-CORE Earthquake Environment NEBS requirements	99.9			% pass
UL Pollution	Degree 3	99.9			% pass
Transport Vibration	NSTA, ISTA compliant	99.9			% pass

2.5.10 Compliance

The MC-Series system will meet the following safety and compliance specifications.

Table 20 Agency Compliances

Parameter	Applicable Standard
FCC	CFR 47, Part 90
UL	UL60950

3 Pre-Installation

This section provides pre-installation information for the MC-Series system at a Sprint Nextel site. Prior to installation, prepare the site with all associated antennas, phone lines and other related site equipment.

3.1 Site Planning

For each of the ensuing site planning subsections, complete the following:

- 1 Identify work to be completed by Sprint Nextel technicians and outside contractors.
- 2 Create a list of materials to be used by Sprint Nextel technicians in completing the work.
- 3 Create statements of work (SOWs) for work to be completed by outside contractors.

3.1.1 Space Requirements

Establish the following specifications to meet National Fire Protection Associations (NFPA) Code and American Society of Heating, Refrigerating and Air Conditioning Engineers (ASHRAE) standards. Any local regulations, as applicable, shall also be adhered to.

- Ceiling height shall be at least 8' 6" above a finished floor to allow enough space for the height of the cabinet and cable access at the top of the cabinet.
- Door dimensions shall be at least 3' wide and 6' 8" high to allow equipment access.
- 36" shall be maintained in front of electrical panel boards (NFPA 70, Article 110-26).
- 36" aisle shall be maintained in front of the MC-Series system cabinet.
- 30" aisle shall be maintained in back of the MC-Series system cabinet.
- No additional space is required on cabinet sides.
- 4' x 4' wall space shall be provided for termination of T1, alarm blocks, environmental sensors, and the master ground bar.
- Rack space for associated hardware, such as a DAS system or an outside powerplant, may be required.
- If battery backup is not provided by the facility owner, include space for an auxiliary backup battery rack. Refer to Sprint Nextel standards for sizing and placement.
- As required, install overhead cable tray to support cables to and from the MC-Series system cabinet per the National Electric Code (NEC), which states: neither the ceiling grid nor its supports may be used to support cable tray or wiring.

3.1.2 Floor Loading

Floor loading is limited to 200 pounds per square foot per specification in section 2.5.3 "Floor Loading".

3.1.3 Anchoring

Anchor the MC-Series system cabinet to the floor using suitable anchors (Hilti or equal). Do not mount the MC-Series system cabinet on casters.

3.1.4 Seismic Zone Installation

All RadioFrame Networks equipment is seismically rated to withstand vibrations of a Level 4 earthquake. The property owner is responsible for any damage to RFN equipment due to building or cabinet structures that are not rated to withstand vibrations of a Level 4 earthquake, or not secured to withstand vibrations of a Zone 4 earthquake.

Ensure that a certified architect specializing in earthquake-resistant installation provides seismic designs and recommendations in areas where the potential loss of the site may outweigh associated costs of earthquake-resistant design. PE stamped drawings shall be provided before the installation proceeds.

3.1.5 Cooling of Equipment

Ensure that the location provides sufficient cooling for the MC-Series system cabinet. Refer to section 2.5.7 "Heat Load" for BTUs generated by the MC-Series system.

3.1.6 Power

Ensure that a DC power source is available that can supply full power requirements for both the MC-Series system cabinet and all ancillary equipment for the installation. This power source may be a bulk DC power source, an internally mounted DC powerplant, or an external DC powerplant. For internal or external DC powerplants, backup batteries may or may not be required, depending on whether or not the powerplant is driven from an Uninterruptible Power Supply (UPS). Refer to Sprint Nextel standards for DC power design.

Any installation of AC power conductors shall be done by a licensed, bonded and insured electrician. Follow standard Sprint Nextel design practices for AC and DC power circuits including any required AC surge protection. Identify any contract labor and materials required.

Refer to section 2.5 "Specifications" for DC power requirements. Plan to use termination lugs. Type is Panduit 2-hole, P/N LCD6-14A, or equivalent. Required crimp tool is CT-1700.

3.1.7 Grounding

The MC-Series system cabinet must be grounded to either a defined equipment grounding system in a Sprint Nextel facility or to the building grounding electrode in a customer facility. Plan to install a grounding system for the MC-Series system cabinet and ancillary hardware. Refer to Chapter 7 and Appendix C of Motorola R56, as modified by Sprint Nextel, for grounding standards. The Master Ground Bar (MGB) will be installed on the wall on the telco board. Plan to use termination lugs. Type is Panduit 2-hole, P/N LCD6-14A, or equivalent. Required crimp tool is CT-1700.

3.1.8 GPS Antennas

Refer to the Motorola *Gen 3 Site Controller System Manual*, 68P80801E30-O document and Sprint Nextel standards for GPS antenna design and installation. Per the NEC (1) any cabling run through an air plenum shall be plenum-rated, and (2) cabling is not to be laid on or suspended from any ceiling grid or attached to the grid supports. Identify any contract labor and materials required.

3.1.9 T1 Service

Install T1 cabling from the point of demarcation to the MC-Series system cabinet, and provide UL497B surge protection for the T1 circuit involved. Use standard Sprint Nextel-approved surge arrestors for the T1 circuit. Per the NEC (1) any cabling run through an air plenum shall be plenum-rated, and (2) cabling is not to be laid on or suspended from any ceiling grid or attached to the grid supports. Identify any contract labor and materials required to extend the T1 service from the demarcation point to the MC-Series system cabinet. For ease of maintenance, RadioFrame Networks recommends locating the demarcation point (SmartJack) in the same space as the MC-Series system cabinet.

Refer to the Motorola *Gen 3 Site Controller System Manual*, 68P80801E30-O document and Sprint Nextel standards for T1 design and installation.

3.1.10 Alarm Blocks

Various alarms or sensors are installed within the Sprint Nextel site building. All alarm wiring terminates at the Environmental Alarm System (EAS) location within the cabinet. All alarm wires shall be tagged and labeled with the appropriate alarm item. All contacts will be normally closed, dry and isolated from ground. Alarm wire will be neatly run and secured using nylon cable ties/clamps every three feet to walls and existing cable tray. All alarm wiring shall be two-wire, 22 AWG.

3.1.10.1 Environmental Alarm System (EAS)

Plan to implement EAS alarm blocks, wiring and sensors as required depending on the installation:

- If the MC-Series system cabinet is deployed as a standalone unit (i.e., as the only cabinet in the area), plan to provide standard Sprint Nextel facility environmental sensors, wiring and connections. Plan to install the EAS alarm blocks on the Telco board on the wall of the space where the MC-Series system cabinet is located, and locate the high-temperature and low-temperature sensors there. Plan to provide conduit or other wire routing from a door sensor, HVAC units (if separate HVAC units are installed for the installation), and AC power failure / surge arrestor failure sensors.
- If the MC-Series system cabinet is deployed as one of a group of cabinets (i.e., in an RF “hotel”), plan to provide standard Sprint Nextel facility environmental sensors, wiring and connections for one of the cabinets. The alarm facilities for the other cabinets will generally not be used. For the cabinets with unused alarms, plan to strap all alarm inputs with 24 AWG solid-conductor wire (e.g., wire from a Category-5 cable). Plan to extend the 25-pair alarm cables with pre-connectorized 25-pair extension cables as needed to allow the alarm blocks to reach the wall space where they are to be mounted. *Do not* plan to leave the alarm blocks in the cabinets or otherwise not mounted.

3.2 Scheduling / Logistics

Procure all non-RFN hardware. Refer to Sprint Nextel documentation for procurement of iSC-3s, EAS and CSU.

- 1 Procure the materials identified in section 3.1 required by Sprint Nextel technicians to complete the installation.
- 2 Initiate the contracts necessary to engage outside contractors to complete the installation work necessary, including any design or engineering work necessary for seismic areas. Any installation requiring seismic certification requires a formal design and installation package from an architect skilled in this area.
- 3 Follow standard Sprint Nextel RF Operations and Site Development procedures for scheduling (a) all installation activity and (b) all necessary datafill work.

Planning should now be complete for the following tasks:

- Securing the MC-Series system cabinet to the mounting surface
- Installing AC or DC power cabling and DC powerplant
- Installing grounding

- Installing T1 cabling
- Installing a GPS antenna system
- Installing facility alarms
- Adding HVAC

3.3 MC-Series Medium Power System Installation Kit

RadioFrame Networks provides the materials listed in Table 21 in an installation kit shipped with the MC-Series Medium Power system.

Table 21 Installation Kit Materials List

Qty	Item	Usage
2	GPS surge arrestors, 2.4 GHz bulkhead N-type, inline	TOR
2	RG58/U, 1 meter coax cable, BNC M to BNC M	BIC to iSC
2	LMR-195-PVC, 84" cable, N-type	iSC to GPS at TOR
20	10/32 Philips thread cutting screw	mounting non-RFN HW in rack
4	Lifting eyelet bolt	cabinet installation
1	Non-disposable ESD wrist strap	ESD prevention
1	Cabinet manufacturer's installation manual	mounting cabinet
4	SMA terminators	spares for RF shelf reconfigurations

3.4 iDEN Configuration

Plan to set up the MC-Series system according to the base radio (BR) parameters specified in the site datafill for the site, including 800/900 MHz, sectorization, cabinet, position and Quad. Corresponding parameters will be set using the System Manager iDEN Configuration page during system set up (section 5.4 "System Setup"). For more information about site datafill parameter settings, refer to the *iDEN OMC-R Configuration Management Parameters Technical Manual*, 68P80802E10.

3.4.1 Cabinet and Position Settings

Before bringing up the system, configure cabinet and position settings to match the datafill BR settings. For more information, refer to section 5.4 "System Setup".

3.4.2 BRs

The MC-Series Medium Power system supports both EBRC and WiDEN (Quad BR) configurations. Quad BRs require multiple RBD2s or an MCRB. An RBD2 can be assigned as an EBRC or can be a carrier of a Quad. An MCRB can be assigned multiple EBRCs or a Quad or partial Quad.

The MC-Series system also supports EBRCs configured with adjacent channels. Instead of configuring a quad BR in the datafill, configure EBRCs using adjacent channels (each adjacent BR is assigned a separate cabinet/position).

3.4.3 Sectorization

In an omni (single-sector) configuration, all RadioBlade transceivers are assigned to the same sector. In a 2- or 3-sector configuration, each group (A, B and C) may be assigned to a different sector. All RadioBlade transceivers within the group must be assigned to the same sector—multiple groups can be assigned to the same sector, but multiple sectors cannot be assigned within the same group.

4 Installation

4.1 Site Inspection

Following all construction work, both exterior and interior, the site and facility shall be in a suitable condition for the installation of communications equipment.

In general, the following considerations need to be observed:

- Facility is secured with lockable doors.
- HVAC
- Grounding
- Interior of facility shall be free of excessive dust.
- All refuse related to the installation tasks shall be removed.

Consideration should be exercised when laying out a site to allow primarily for all code requirements for spacing, and then the most efficient use of space. Special attention shall be given to future expansion with regard to cable runway heights, electrical outlet placement, and equipment placement.

4.2 Receipt of Equipment

The MC-Series Medium Power system is provided pre-installed in a standard 79" tall, 19" wide EIA-compliant cabinet with the following equipment:

RFN

- BTS Interface Chassis (BIC)
- Airlink Interface Chassis (AIC)
- RadioBlade Shelf (RBS)
- RF Shelf (3 each, medium power)
- Power Distribution Unit (PDU)
- MC-Series System Installation Kit

Non-RFN

- CSU (must be installed onsite)
- iSC-3 (primary and secondary)
- EAS

4.2.1 Equipment Inspection

Inspect the equipment immediately upon receipt. If obvious damage has occurred to the shipping container before unpacking, contact the shipping agent. Ask that a representative of the shipping company be present while the equipment is unpacked.

Check for the following:

- loose or damaged equipment in the pre-installed cabinet
- dents, scratches or other damage on all sides of each component

If any equipment is damaged, contact the shipping company immediately, then a Sprint Nextel representative.

4.2.2 Equipment Inventory

Check all MC-Series Medium Power system equipment against the itemized packing list to ensure receipt of all equipment. If available, check the sales order with the packing list to account for all equipment ordered. Contact the Sprint Nextel representative to report missing items and for additional information.

4.3 Mounting the MC-Series Medium Power System Cabinet

Refer to the manufacturer's documentation (included with the MC-Series System Installation Kit) for installation procedures for mounting and securing the MC-Series Medium Power system cabinet.



Warning!

Always use two or more persons whenever moving a cabinet. A fully configured equipment cabinet weighs approximately 800 lbs (360 kg).

This section describes procedures for mounting the following non-RFN equipment in the MC-Series system cabinet (normally the iSC-3s and EAS are shipped installed):

- iSC-3 (two)
- EAS
- CSU



Warning!

Any equipment installed in the MC-Series system cabinet shall be UL listed.



User equipment that is installed shall not draw a combined current of more than 5 Amps. This combined total shall be determined from the marked current rating label of the equipment to be installed.

Figure 30 Locations of Non-RFN Hardware in MC-Series Medium Power System Rack

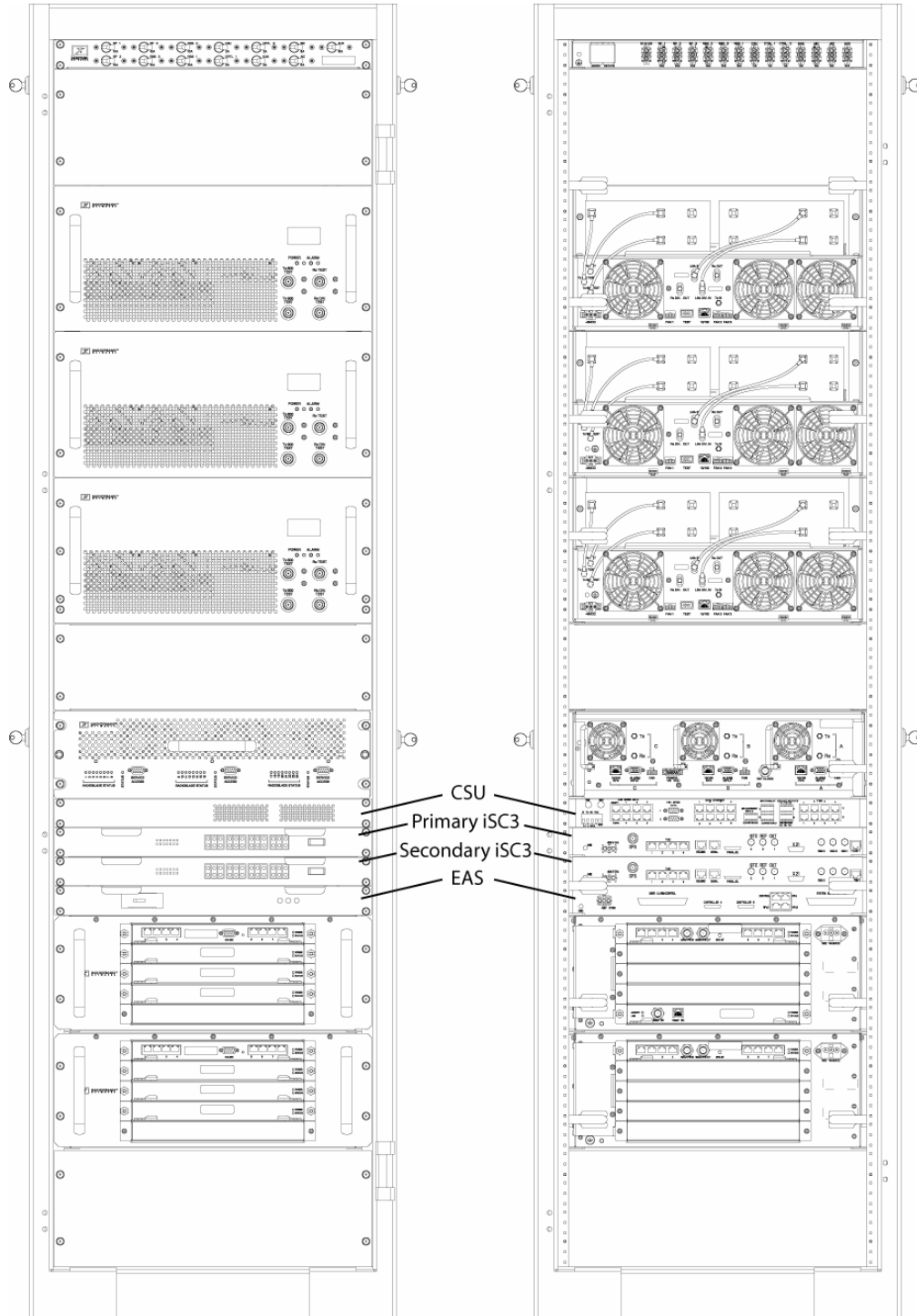

4.3.1 iSC-3s

Note: Typically, the iSC-3s are installed by RadioFrame Networks before the MC-Series Medium Power system is shipped. If you need to install an iSC-3, follow this procedure.

- 1 While supporting the iSC-3, slide the iSC-3 into the cabinet mounting position.
- 2 Mount the iSC-3 in the location shown in Figure 30. If necessary, install side rails in the mounting position in the rack.
- 3 Secure the iSC-3 to the cabinet mounting rails using the four mounting screws provided with the unit. Tighten the screws to 4.5 Nm (40 in-lb).
- 4 Connect the RFN-provided ground cable (P/N 820-0609-10; ISC1 to GND BAR) between the cabinet ground bar and the grounding lug on the rear of the iSC-3, and ensure the connection is tight.
- 5 Connect the RFN-provided power cable (P/N 820-0613-50; PDU-CTRL_1 to ISC1) between the iSC-3 power and the CTRL circuit breaker on the PDU (CTRL 1 for the primary iSC and CTRL 2 for the secondary iSC).
- 6 Repeat steps 1 through 4 to mount the secondary iSC-3 (cable labels will show ISC2 instead of ISC1).
- 7 Connect the two iSC-3s according to Sprint Nextel's installation procedure.
- 8 Refer to Figure 31. Using the RFN-provided coax cable (P/N 111-0001-02; BIC-ERTM 5 MHz IN to ISC1 REF OUT-1), connect the primary iSC-3 port SITE REF OUT 1 [K] to the BIC ERTM port 5 MHz IN [L].
- 9 Terminate the two remaining SITE REF OUT ports on the primary iSC-3, and terminate all three SITE REF OUT ports on the secondary iSC-3.
- 10 Using the RFN-provided coax cable (PN 111-0001-02; BIC-CRTC to iSC1 REF OUT-1), connect the primary iSC-3 port 10B2-1 to BIC CRTC port 10Base2 iSC.
- 11 Terminate the two remaining iSC-3 10B2 ports on the primary iSC-3, and terminate all three 10B2 ports on the secondary iSC-3.

Note: Figure 31 does not show all cabling. For complete cabling information, refer to Appendix C "Medium Power iDEN Microcell Rack Stack-Up, 3-Sector (Default) Configuration".

Figure 31 Connections between the Primary iSC and BIC

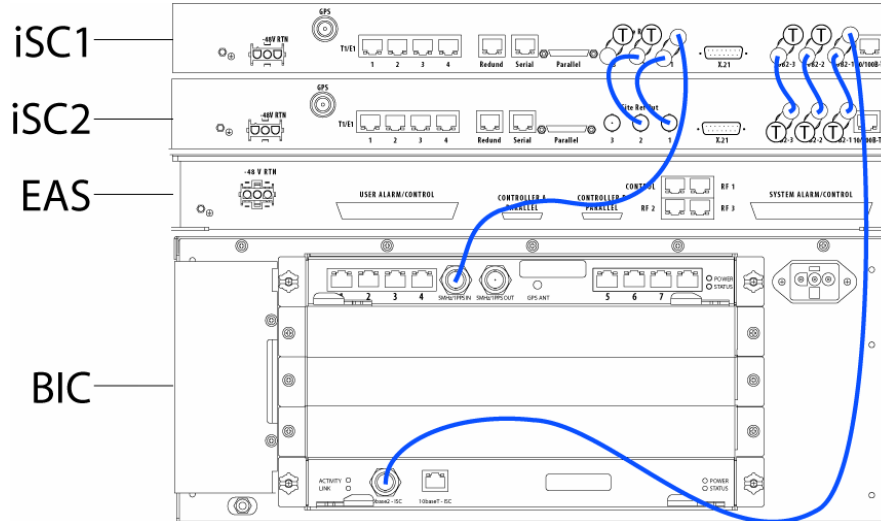

4.3.2 EAS

Note: Typically, the EAS is installed by RadioFrame Networks before the MC-Series Medium Power system is shipped. If you need to install an EAS, follow this procedure:

- 1 While supporting the EAS, slide the EAS into the cabinet mounting position.
- 2 Mount the EAS in the location shown in Figure 30.
- 3 Secure the EAS to the cabinet mounting rails using the four mounting screws provided with the unit. Tighten the screws to 4.5 Nm (40 in-lb).
- 4 Connect the RFN-provided ground cable (P/N 820-0609-10; EAS to GND BAR) between the cabinet ground bar and the grounding lug on the rear of the EAS, and ensure the connection is tight.
- 5 Connect the RFN-provided power cable (P/N 820-0616-50; EAS to PDU-EAS) between the EAS power and the EAS circuit breaker on the PDU.
- 6 Connect EAS to each iSC-3 according to Sprint Nextel's installation procedure.
- 7 Refer to Figure 32. Connect the RFN-provided contact closure alarm wires from the CONTROL port on the EAS (RJ-45) to the STATUS connectors on the PDU (Molex).

Figure 32 Connection between EAS Control Port and PDU Status Connectors

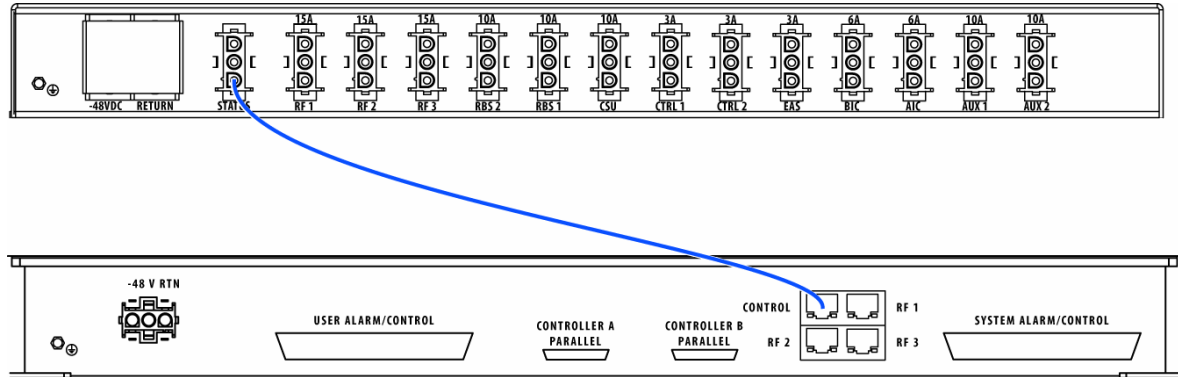

For complete cabling information, refer to Appendix C “Medium Power iDEN Microcell Rack Stack-Up, 3-Sector (Default) Configuration”.

4.3.3 CSU



Always connect the power cable to the CSU **before** connecting the power cable to the PDU.

- 1 Remove the cabinet mounting rails from the CSU mounting location.
- 2 While supporting the CSU, slide the CSU into the cabinet mounting position.
- 3 Mount the CSU in the location shown in the cabinet illustration earlier in this section. As necessary, follow the equipment manufacturer's installation procedure for mounting the CSU in a 19" standard EIA-compliant rack.
- 4 Connect the RFN-provided ground cable (P/N 820-0609-10; CSU to GND BAR) between the cabinet ground bar and the grounding lug on the rear of the CSU, and ensure the connection is tight.
- 5 Connect the RFN-provided power cable (P/N 820-0615-50; CSU to PDU-CSU) to the CSU power.
- 6 Connect the other end of the power cable to the circuit breaker on the PDU.
- 7 Connect the CSU to each iSC-3 according to Sprint Nextel's installation procedure.
- 8 Using a cat-5 cable, connect 10/100 Ethernet port 1 on the CSU to port 8 on the BIC ERTM for remote-management access.

For complete cabling information, refer to Appendix C “Medium Power iDEN Microcell Rack Stack-Up, 3-Sector (Default) Configuration”.

4.4 Mounting Auxiliary Equipment

Follow Sprint Nextel's procedures for mounting the following auxiliary equipment:

- Powerplant
- Backboard
- Surge arrestors

- Alarm blocks
- Environmental sensors

4.5 Cabinet-to-Site Cabling

Follow Sprint Nextel's procedures for installing the following wiring at the site, and then complete the procedures in this section to complete the cabinet-to-site cabling. See Appendix C for top of the rack connections.

- Grounding
- T1
- GPS surge arrestors
- EAS alarm cabling
- RF (Tx / Rx / Rx diversity)
- Power

Figure 33 Top of the Rack (TOR), Dual-Band Bulkhead, Cabling and Equipment

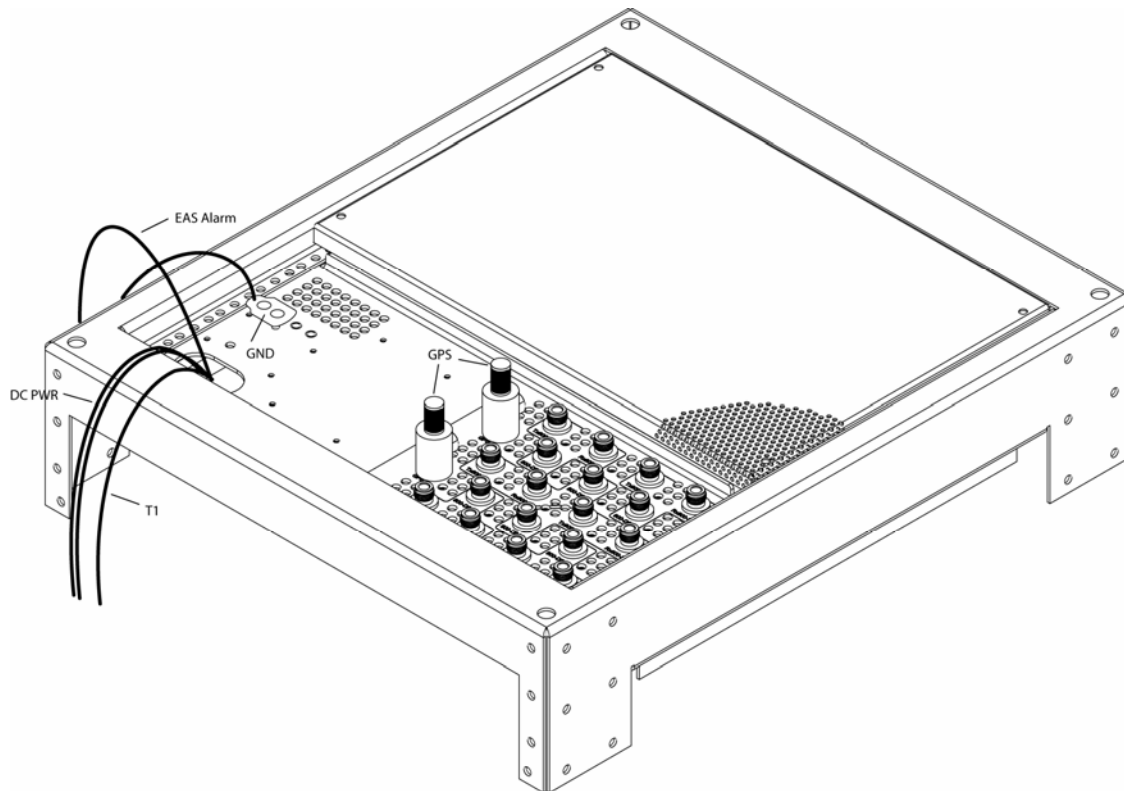

4.5.1 Grounding

- 1 Ground the cabinet ground bar to the site according to Sprint Nextel's installation instructions using 2-hole terminal lug. Type is Panduit 2-hole, P/N LCD6-14A, or equivalent. Required crimp tool is CT-1700.

- 2 Connect the site ground to the ground at the top of the rack according to Sprint Nextel's installation procedures (see Figure 33 for ground location at the top of the rack).

4.5.2 T1

- 1 Follow Sprint Nextel procedure for routing the site T1 cable through the top of the cabinet as shown in Figure 33.
- 2 Connect the T1 cable to the CSU according to Sprint Nextel's installation instructions.

4.5.3 GPS Surge Arrestor

Follow Sprint Nextel's procedure for installing GPS equipment at the site. Then complete the following procedure:

- 3 Install the two RFN-provided GPS surge arrestors at the top of the rack (Figure 33).
Note: Make sure the element on the side of the surge arrestor is accessible, depending on the site configuration.
- 4 Connect the cable from GPS surge arrestor to the primary iSC-3, rear port GPS (P/N820-0620-00; GPS-ISC to GPS_1 TOR).
- 5 Connect the cable from the second GPS surge arrestor to the secondary iSC-3, rear port GPS (P/N820-0620-00; GPS-ISC to GPS_2 TOR).
- 6 Connect each GPS surge arrestor to the GPS antenna coax according to Sprint Nextel's installation procedures.

4.5.4 EAS Alarm Cabling

- 1 Follow Sprint Nextel's procedure for routing the two 50-pair alarm cables through the top of the cabinet, as shown in Figure 33.
- 2 Connect the two 50-pair alarm cables to the back of the EAS:
EAS: USER ALARM / CONTROL
EAS: SYSTEM ALARM / CONTROL
- 3 Terminate the two 50-pair alarm cables to the two blocks on the backboard, making sure that each cable is connected to its specific block.

4.5.5 RF (Tx / Rx / Rx diversity)

The MC-Series Medium Power system cabinet provides the following RF loads at the top of the rack for connection to the site RF distribution system:

- Tx 1, Tx 2, Tx 3
- Rx 1, Rx 2, Rx 3
- DIV 1, DIV 2, DIV 3

Connect the female N-type connectors to the onsite RF distribution system (antenna, DAS, etc.).

4.5.6 Power



Verify that all breakers in the PDU are in the OFF position prior to proceeding. Leave them in the OFF position until instructed otherwise.

Connect the powerplant to the PDU using two two-hole terminal lugs. Type is Panduit 2-hole, P/N LCD6-14A, or equivalent. Crimp tool needed: CT-1700.

5 Final Checkout and Commissioning

The procedures in this chapter describe final checkout for each portion of the MC-Series Medium-Power system. This chapter describes procedures for:

- Prerequisites
- Checkout procedures
- Final checkout setup
- Initial power
- System setup
- System verification
- Functionality test

5.1 Prerequisites

Ensure that the following has taken place:

- The T1 is live and has been tested
- The datafill has been completed, including BR cabinet and position assignments, and conforms to the recommended datafill shown in section 6.1.3 “Recommended Datafill Parameters”
- Site configuration is available
- All cabling and installation work has been completed and all punchlist items corrected

Required Tools:

- R2660 Series Communication System Analyzer
- Digital RF meter
- Laptop computer to bring up the MC-Series system. At a minimum, the laptop must be loaded with the following fully functional equipment (or equivalent):
 - Pentium II / 233 MHz (Pentium III / 500 MHz recommended, or better)
 - 128 MB of memory (256 MB recommended)
 - 10 GB hard drive (64 MB disk drive space minimum available for software)
 - 12x (or faster) CD-ROM (USB memory stick with 64 MB recommended)
 - Windows 98 (Windows 2000 Professional or better recommended)
 - Internet Explorer 5.5 or later (not Mozilla Firefox)
- One Ethernet port and one 9-pin serial port

- 6-foot Cat-5 (or 5e/6) Ethernet cable (EIA/TIA 568B) to connect to the BIC CRIC
- Straight-through, male-to-female serial cable (DB9/RS232)
- 50 Ω terminating loads for all RF ports to be used according to the site configuration

Ensure that the following RadioFrame Networks software is available:

- CD ROM (backup)
- New versions can also be downloaded from RFN web site to the local root directory (C:/)

For local software downloads, have the following available on the laptop:

- FTP server software—WFTPD32 is shareware that can be downloaded from the following site: <http://www.wftpd.com/>
- Terminal emulation software (e.g., PROCOM)

5.2 Checkout Procedures



Verify that all breakers in the PDU are in the OFF position prior to proceeding. Leave them in the OFF position until instructed otherwise.

- 1 Verify that all breakers in the PDU are in the OFF position prior to proceeding. Leave them in the OFF position until instructed otherwise.
- 2 Conduct a visual inspection of the cabling on the rear of the cabinet verifying that all connections are in place, tight, and complete.
- 3 Add and remove RadioBlade transceivers according to the site configuration. Refer to section 7.9.4 “RadioBlade Transceiver Replacement”.
- 4 Verify that cabling matches the site configuration.
Refer to Appendix C “Medium Power iDEN Microcell Rack Stack-Up, 3-Sector (Default) Configuration”.
- 5 Install 50 Ω 2 W terminators on all unused Tx / Rx / Diversity ports on the top of the cabinet.
- 6 Verify that there is DC power at the supply terminals on the PDU and that the polarity is correct. Refer to section 2.5 “Specifications” for more information.

5.3 Initial Powering Procedure

- 1 Verify that all breakers in the PDU are in the OFF position.
- 2 Ensure that the power switches on the iSC-3s and the EAS are all in the OFF position.
- 3 Using the breakers on the PDU, turn up the equipment by completing the following steps, verifying that each component is operational before proceeding to the next step.
- 4 Using the breaker on the PDU and the power switch on the front of the primary iSC-3, turn up the primary iSC-3, and then verify that it is operational and that GPS lock has been established before proceeding. For more information, refer to the Motorola document *Gen 3 Site Controller System Manual*, 68P80801E30-O.

- 5 Using the breaker on the PDU and the power switch on the front of the EAS, turn up the EAS, and then verify that it is operational before proceeding. For more information, refer to the Motorola document *Gen 3 Site Controller System Manual*, 68P80801E30-O.
- 6 Using the breaker on the PDU and the power switch on the front of the secondary iSC-3, turn up the secondary iSC-3, and verify that it is operational before proceeding. For more information, refer to the Motorola document *Gen 3 Site Controller System Manual*, 68P80801E30-O.
- 7 Using the breaker on the PDU, turn up the CSU.
- 8 Configure the CSU according to the manufacturer's documentation and Sprint Nextel standards.
- 9 Using the breaker on the PDU, turn up the BIC, AIC and RBS 1, and then verify that all three components are operational before proceeding.
- 10 Wait approximately 3 minutes for the following indications:
 - RBS: The STATUS LED for each Group will turn green in this order: A, B and then C.
 - RBS: The RADIOBLADE TRANSCEIVER STATUS LEDs will turn red and then green for each present RadioBlade transceiver. If no RadioBlade transceiver is present, the LED will not light. To verify the contents of the RBS, pull out the shelf (powering off is not required) and inspect the RadioBlade transceivers and their respective status LEDs. Referring to Figure 34, reinsert the RBS. To do this, press up on one side rail locking arm and press down on the other side rail locking arm, and then push the unit into the rack.
 - BIC CRIC and AIC CRIC: The POWER and STATUS LEDs will turn red and then green. All other BIC and AIC card LEDs will turn green.
- 11 Using the breaker on the PDU, turn up RF Shelf 1, RF Shelf 2 and RF Shelf 3 and then verify that each RF shelf is operational before proceeding.
The POWER and ALARM LEDs on the front of each RF shelf will turn green.

Figure 34 Location of RBS Side Rail Locking Arms



5.4 System Setup

- 1 Connect the laptop to port 8 of the BIC CRIC using an Ethernet (Cat-5) cable.

Figure 35 Location of BIC CRIC Laptop Connection Port

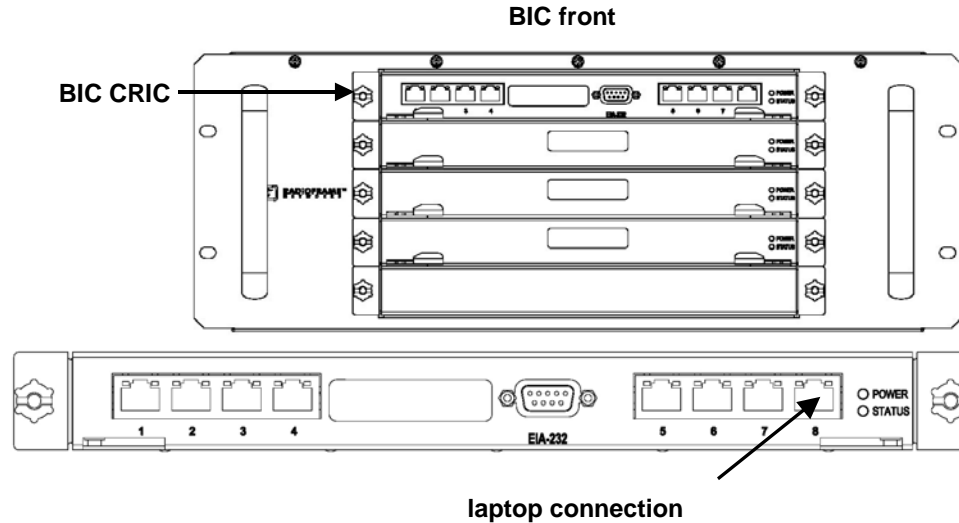

- 2 Set the laptop IP address to 192.168.200.4 (static) and turn off DHCP.
Note: System Manager does not support DHCP. Therefore you must configure a static IP address on the same subnet as the System Manager HTTP server.
- 3 Start System Manager.

Launch a browser session and enter the MC-Series Medium Power system IP address: <http://192.168.200.5>. The System Manager Home page appears, which contains five tabs to select from:

- *Home*—displays a welcome banner and a link for setting up users and changing the MC-Series system password.
- *System Configuration*—depicts the status of the BIC, AIC and RBS.
- *Alarms*—displays alarm information.
- *Performance Monitoring*—displays real-time performance information.
- *Diagnostics*—provides tools for testing.
- *Support*—displays support information, including online help.

Figure 36 System Manager Welcome Screen



4 Log in to System Manager.

Select the System Configuration tab to display the login window. For **User Name**, type **Sysadmin** (case sensitive). For **Password**, type **Radioframe** (case sensitive), and then select **OK**. To change the password, refer to section 6.2.1.2 “Changing the System Password”.

Figure 37 System Manager Log-in Window



Note: Before proceeding to iDEN Configuration, it is a good idea to ensure that the MC-Series Medium Power software is the latest released version. Refer to section 6.2.2.6 “Viewing Hardware and Software Versions”.

- 5 Select the iDEN Configuration link at the bottom of the System Configuration page. On the iDEN Configuration page, make sure the configuration agrees with the site datafill and also the RF cabling. The sector assignments must match the cabling in the back of the cabinet. All cab/pos values must be associated with the appropriate sector. The MC-Series system will attempt to register all BRs with the cab/pos values selected in this menu. An example configuration is shown in Figure 38. For more information, refer to section 3.4 “iDEN Configuration”.

Figure 38 iDEN Configuration Page

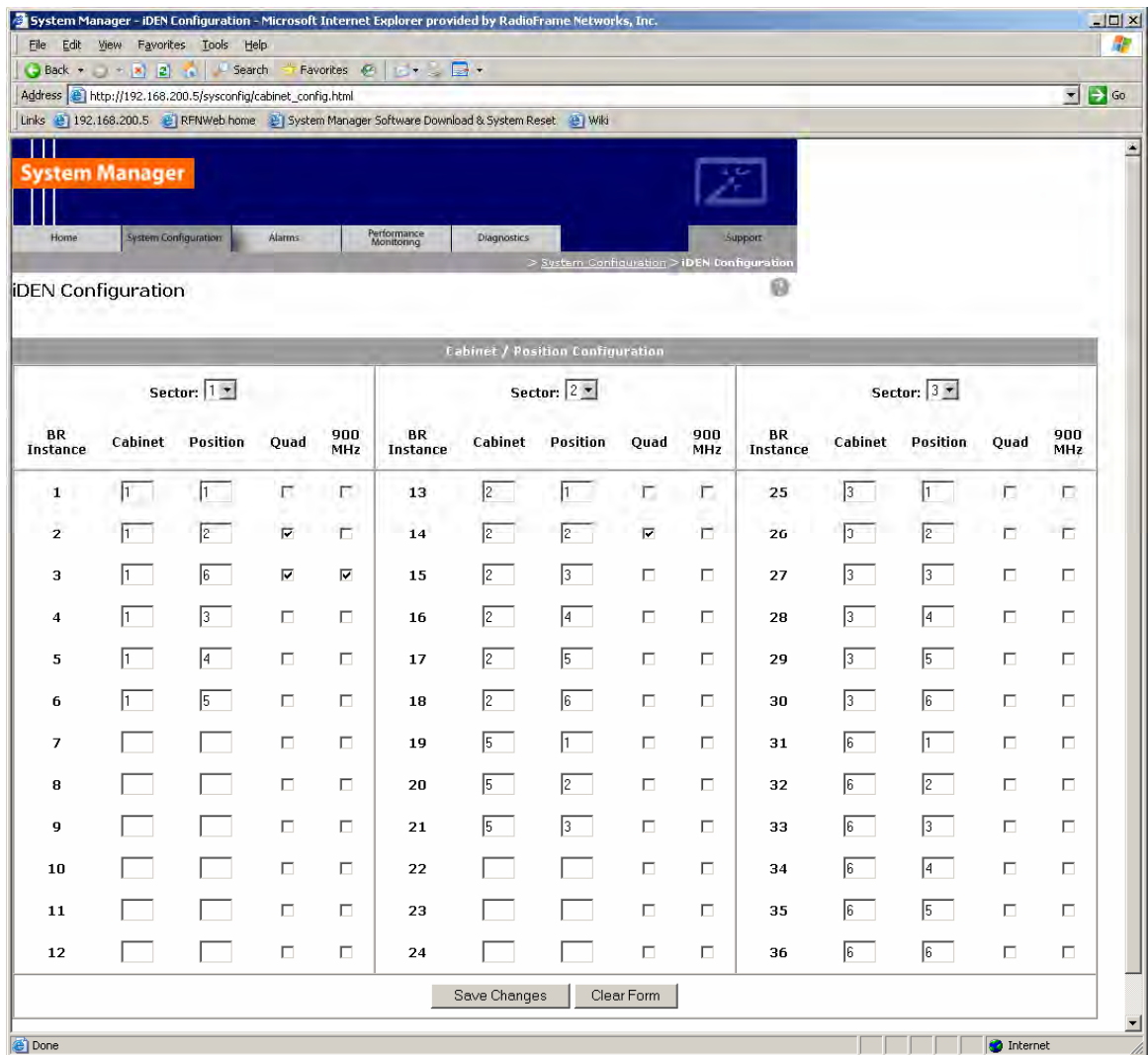

- 6 After iDEN configuration is updated (by clicking on Save Changes), a System Reset is required. (Refer to section 8.2 “Performing a System Reset” if necessary).
- 7 Go to the Performance Monitoring page (section 6.2.3.1 “Local Performance Monitoring”) and confirm that are BRs that were intended to be brought up are in the UEA state. If there are BRs that are not active, select the **Alarms** tab and review the **Active Alarm Manager** for any active alarms. For more information, refer to section 7.5.3 “System Manager Alarms”.

8 Validate ToR output power or go to step 9.

Connect the General Dynamics R2660 Series Communication System Analyzer to the top of the rack Tx OUT 1. Then set up the R2660 for iDEN Base mode. Enter the control channel frequency for sector 1, and then measure the output power of that frequency.

For specifications, refer to section 2.5.8.2 “Transmitter Performance Summary”. The default is +29 dBm per carrier, assuming that the datafill parameter defaultTxPower is set to 9.5. If necessary, adjust the datafill parameter (refer to section 6.1.4.1 “defaultTxPower”).

9 Measure the SQE and frequency error for the control channel to see if they are within specifications.**10** Verify that all BRs have the same output power.

For each channel, enter the frequency into the R2660 and verify that the SQE, frequency error, and power level are all within specifications (refer to Table 18 “Receiver Performance Summary” on page 38).

11 Repeat steps 5 through 10 as needed for each sector.**12** Review the **Active Alarm Manager** for any un-cleared alarms.

Refer to section 7.5.3 “System Manager Alarms” for more information.

5.5 Functionality Test

RadioFrame Networks recommends that a certification process be completed to ensure proper operational performance and to verify the integrity of the following services:

- Voice quality for 3:1 Interconnect Voice
- Voice quality for 6:1 Private Group Dispatch Voice
- Call setup reliability for 3:1 Interconnect Voice
- Call setup reliability for 6:1 Private and Group Dispatch Voice
- Call stability for all of the above voice services
- Connection quality, stability, delay and perceived throughput for the Packet Data service
- Connection setup reliability for Packet Data
- Idle SQE quality and variation
- Call up SQE quality and variation
- Short Message Service
- Handover and cell reselection
- Performance will also be validated by collecting at least one week of performance statistical data

Refer to Appendix D “Functionality Test Procedures” for procedures to conduct functionality testing.

Note: MC-Series Medium Power system does not support 6:1 VSELP calls or Circuit-Switched data.

6 Management—Datafill, Configuration and Optimization

This section describes configuration techniques that affect the behavior of the MC-Series Medium Power system. Section 6.1 covers the datafill parameters as they differ from the Motorola EBTS. Section 6.2 covers configuration options using System Manager, with sections 6.2.1 and 6.2.2 introducing basic operations and 6.2.3 presenting optimization procedures.

6.1 Datafill

The MC-Series Medium Power system is designed for compatibility with the Motorola EBRC and QUAD Base Radios (BRs). However, due to architecture differences between the two systems, not all datafill parameters apply equally to the MC-Series Medium Power system.

This section describes only those datafill parameters that need to be taken into consideration when used with the MC-Series Medium Power system. Any datafill parameter not described here can be assumed to behave identically to the Motorola EBTS. This section includes:

- 6.1.1 Parameters that RFN does not support
- 6.1.2 Parameters that have no effect on the MC-Series Medium Power system
- 6.1.3 Parameters that RFN supports, but which need to be setup differently from the typical setup for a Motorola BR

6.1.1 Unsupported Datafill Parameters

The following datafill parameters are currently not supported.

6.1.1.1 **steThresholdMode**

The Slot Timing Error Threshold Mode parameter has three different purposes:

- Setting to zero allows the EBTS to automatically determine the STE threshold based on history of inbound transmissions.
- Setting to maximum value of 250 essentially disables the use of STE filtering.
- A manual override exists by setting the parameter in the range of 1 to 249. The default value is set to 250.

This datafill parameter will be supported in the MC-Series Medium Power system starting with 15.0 releases of System Manager software.

6.1.1.2 **brPwrReducModeAcg**

The BR Power Reduction parameter is used to enable/disable the Power Reduction feature on a per-BR basis. The default value is set to 'ON' and it is on-line changeable.

This feature will be supported in the MC-Series Medium Power system starting with 15.0 releases of System Manager software.

6.1.2 Parameters that Do Not Apply to the MC-Series Medium Power System

The following parameters have no effect on the MC-Series Medium Power system. There is no functional equivalent in the MC-Series Medium Power system, and as such the parameters can be ignored.

6.1.2.1 **combinerType**

This parameter specifies the type of combiner used to connect the cells Base Radios to the antenna. The options are hybrid and cavity. The MC-Series Medium Power system is similar to a cavity type combiner physically but it does not have the same frequency limitations as the cavity combiner that this parameter is used for.

6.1.3 Recommended Datafill Parameters

The following parameters need to be set differently than what is currently set with Motorola BR. These settings are not required but recommended for best operation.

6.1.3.1 **PCC**

The power control constant is broadcast on the BCCH and is used by the MS to calculate a target value for its transmit power. For Indoor Pico and Micro-Cell applications this value will vary depending upon the RF environment (i.e., if used outdoors the value will be quite different from an indoor scenario). For the MC-Series Medium Power system, the setting of this parameter depends on what is connected between the MC-Series Medium Power system and the antenna. The default value should be calculated in accordance with Motorola guidance detailed in the Datafill Parameter Guide. It should be noted that in cases in which the Mobile subscribers are near the antenna source (downlink limited), the handsets could transmit at a much lower level than is the case with a Macro site. Lowering this parameter forces the mobile to operate at fairly low Tx level thus conserving battery life. In cases where the MC-Series Medium Power system is connected to a DAS, the gains and losses of the paths should be taken into consideration. Additionally the level of uplink interference should be considered when determining this value.

6.1.3.2 **Pto (transmit power)**

The Cells outbound transmit power referenced at the output of the RF Distribution System Antenna Port. It is used as a reference point value when computing the link budget of the system. RFN recommends that the value of this parameter be set appropriate to the TOR output power, which is determined by the defaultTxPower parameter (see below).

6.1.4 rxTxGain = 0

This parameter is the difference in gain between the receiver and transmit antenna paths expressed in dB. The MC-Series Medium Power system does not use this parameter directly.

6.1.4.1 **defaultTxPower**

Note: Refer to release notes for range information.

This is the average output power of the PA, measured at the RF connector of the BR. For the MC-Series Medium Power system, this parameter can be used to adjust the output power of the system. The gain at the shelf is fixed and cannot be altered as was the case

with the 800-only RF Shelf. The MC-Series Medium Power system has a different range of output levels than a standard Motorola EBTS, and as such, these values will map to a different set of actual Tx output power levels. (The correspondence is shown in Table 17 in section 2.5.8.3 .) The nominal maximum Tx power at the top of the rack with a maximum variation of ± 2 dB is +29 dBm. The dynamic range is 11 dB.

6.2 System Manager, Configuration and Optimization

6.2.1 Navigating System Manager

6.2.1.1 Logging into System Manager

- 1 Connect a laptop computer to port 8 of the BIC CRIC using an Ethernet (Cat-5) cable.
- 2 Start System Manager by typing the IP address of the MC-Series system into Internet Explorer (default 192.168.200.5).
- 3 The System Manager Home page appears and displays five tabs to select from to set up and monitor the RadioFrame MC-Series system.

Figure 39 System Manager Home Page



- *Home*—displays a welcome banner and a link for setting up users and changing the MC-Series system password.
- *System Configuration*—depicts the status of the BIC, AIC, RBS and RadioBlade transceivers.
- *Alarms*—displays alarm information.
- *Performance Monitoring*—displays real-time performance information.
- *Diagnostics*—provides tools for testing.
- *Support*—displays support information, including online help.

- 4 To log in, select any tab.
- 5 For **User Name**, type the MC-Series system user name.
- 6 For **Password**, type the MC-Series system password.
- 7 To save the password, check '**Save this password in your password list**' checkbox.
- 8 Select **OK**.

Figure 40 Network Password Pop-up Dialog Box



6.2.1.2 Changing the System Password

- 1 Select the Home tab, and then select the User Provisioning link.
- 2 For Select User Name, choose the appropriate system title from the dropdown menu.
- 3 Typically, choose Sysadmin (Entire System) unless instructed to do otherwise.
- 4 Type the Current Password.
- 5 Type the New Password and confirm it, then select Save Changes.

Figure 41 Set System Manager Password Dialog Box

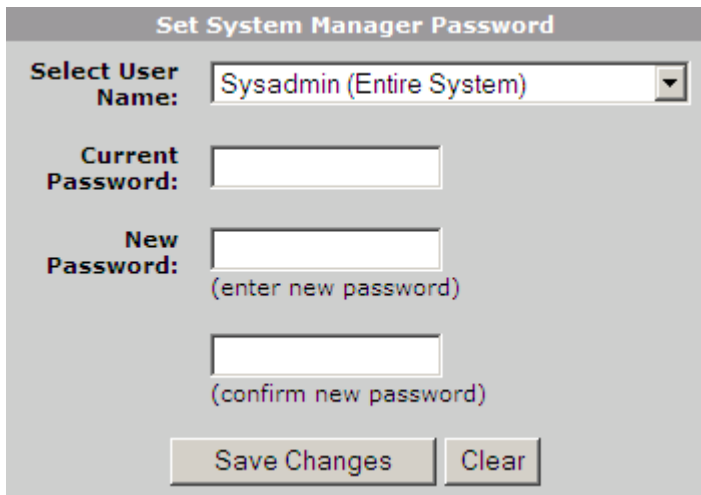

The dialog box is titled "Set System Manager Password". It contains the following elements:

- Select User Name:** A dropdown menu with "Sysadmin (Entire System)" selected.
- Current Password:** A text input field.
- New Password:** A text input field with the placeholder text "(enter new password)".
- Confirm New Password:** A text input field with the placeholder text "(confirm new password)".
- Buttons:** "Save Changes" and "Clear".

6.2.2 Configuring the MC-Series Medium Power System

6.2.2.1 Navigating the System Configuration

The System Configuration page displays icons depicting the AIC, BIC and the RBS (see Figure 42). The colored bar beneath each icon represents the status of that component as listed in Table 22.

Figure 42 BIC Configuration Page Showing AIC, BIC and RBS Status

The screenshot displays the 'System Manager' interface for BIC configuration. The top navigation bar includes 'Home', 'System Configuration', 'Alarms', 'Performance Monitoring', 'Diagnostics', and 'Support'. The current page is 'BIC Configuration', with a breadcrumb trail '> System Configuration > BIC'. The page is divided into three main sections: configuration options and a status overview.

BIC Device Configuration: This section contains three input fields: 'Device Name' (limit 31 characters) with the value 'BIC', 'IP Address' with the value '192.168.200.5', and 'Building Address' (limit 3,000 characters) which is currently empty. A 'Save Changes' button is located below these fields.

Carrier IP Configuration: This section contains three input fields: 'IP Address' with the value '10.152.244.10', 'Network Mask' with the value '255.255.255.248', and 'Default Gateway' with the value '10.152.244.9'. A 'Save Changes' button is located below these fields.

Other Configuration Options: This section lists several links: [Software Download & System Reset](#), [Software Version Information](#), [iDEN Configuration](#), [RBS Status](#), and [RadioBlade Alarms](#).

Status: This section provides a visual overview of the system components. It includes a 'legend' link and three status indicators, each with a corresponding device icon and a green bar below it: 'BIC PLL: LOCKED', 'AIC PLL: LOCKED rear port 2', and 'RBS'. The status indicators are connected by vertical lines, suggesting a hierarchical or interconnected relationship between the components.

The bottom of the page shows the time '21:52:51 AUG 08' and the breadcrumb trail '> System Configuration > BIC'.

Table 22 Status Color Interpretations

Color	Status Indicator	Description
Green	Active	The component is installed, configured and operational.
Yellow	Inactive	The component is installed but has not been configured.
Red	Alarm	The component has returned an alarm condition. Refer to section 7 “Scheduled and Unscheduled Maintenance” for specific alarm conditions.

- 1 To view configuration information for a component, select its icon.
- 2 The component configuration page displays the device name, IP address, building address and other pertinent information.
- 3 To return to a previous page, select the component pathname at the top of the tab (System Configuration>BIC>AIC...), or to return to the BIC configuration page, select the System Configuration tab at any time.

6.2.2.2 Viewing the Status of the RadioBlade Transceivers

The RBS Status, RadioBlade Alarms, and RadioBlade Control (formerly RadioBlade Statistics) pages show the MCRB along with the RBD2. Select the **RBS STATUS** link at the bottom of the System Configuration page. The RBS Status page displays an icon for each RadioBlade transceiver installed in the RBS, and indicates the status of the RadioBlade transceiver and whether or not it is locked. At the top of the page are three icons representing the status of each group (A, B and C) in the RBS.

Figure 43 RadioBlade Status Page

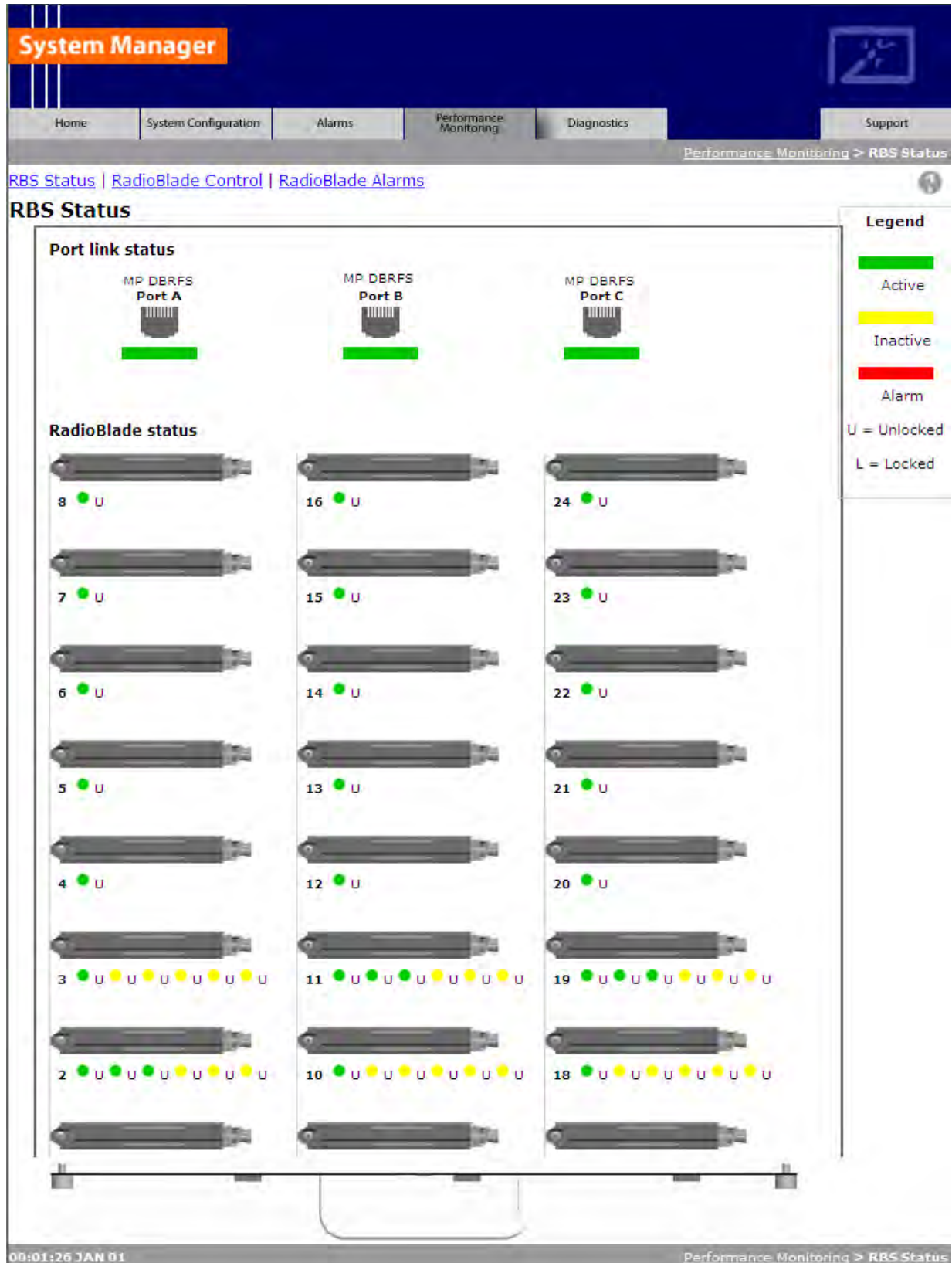

6.2.2.3 Locking and Unlocking a RadioBlade Transceiver

Select the RadioBlade transceiver icon or the RadioBlade Control link at the top of the RBS Status page. The RadioBlade Control page displays the following information for each iDEN RadioBlade transceiver:

- RadioBlade transceiver Slot (1-24)
- RB ID
- State
- RB PLL Status
- Carrier ID
- Transmit Frequency
- Cabinet
- Position
- Locked/Unlocked

To lock or unlock a RadioBlade transceiver, select the icon in the Locked/Unlocked column.

Figure 44 RadioBlade Control Page

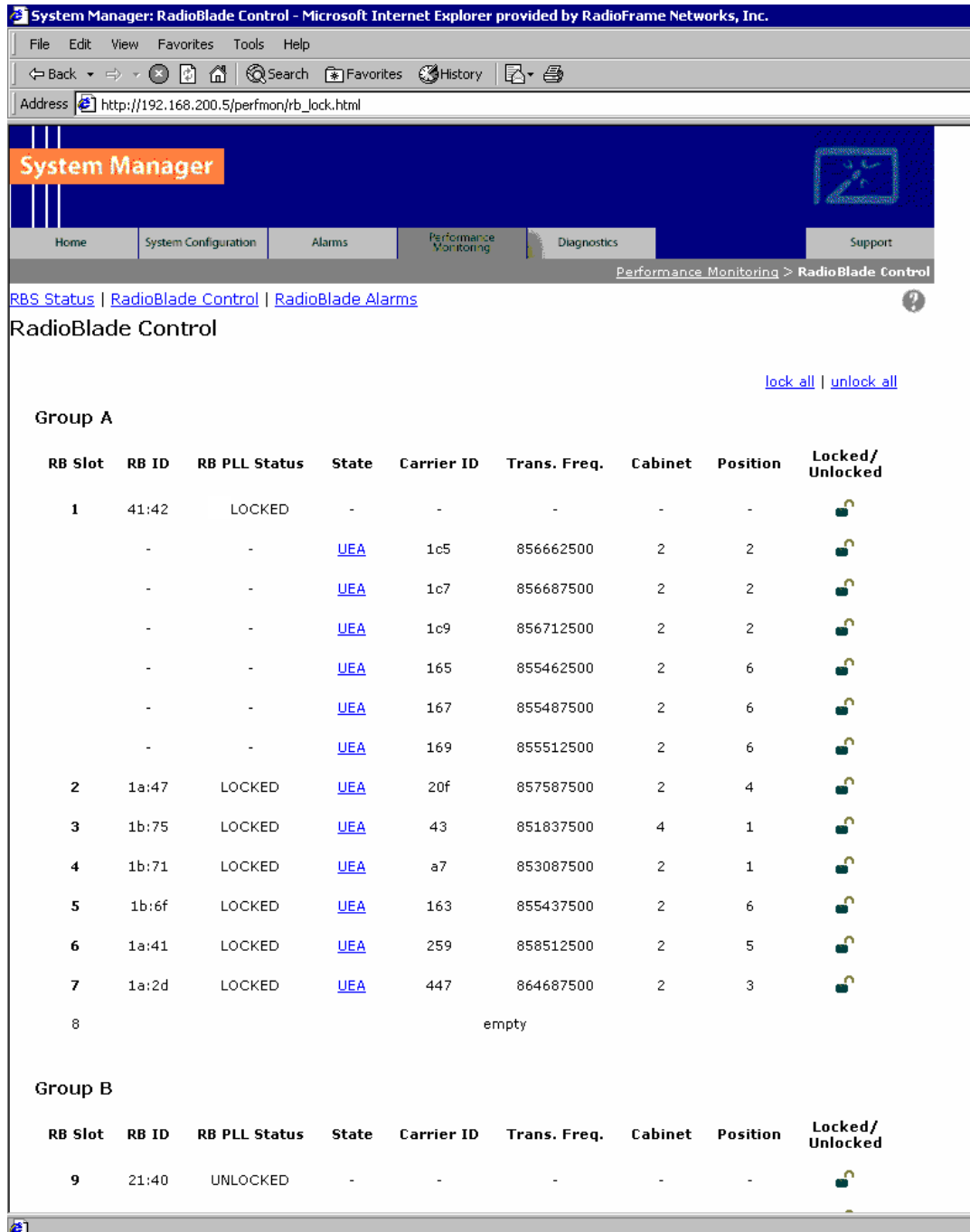

6.2.2.4 RadioBlade Alarms Page

The RadioBlade Alarms Page displays information for both types of RadioBlades either on a per-channel or per-blade basis, as appropriate for that type of alarm. This page is shown in Figure 45

Figure 45 RadioBlade Alarms Page

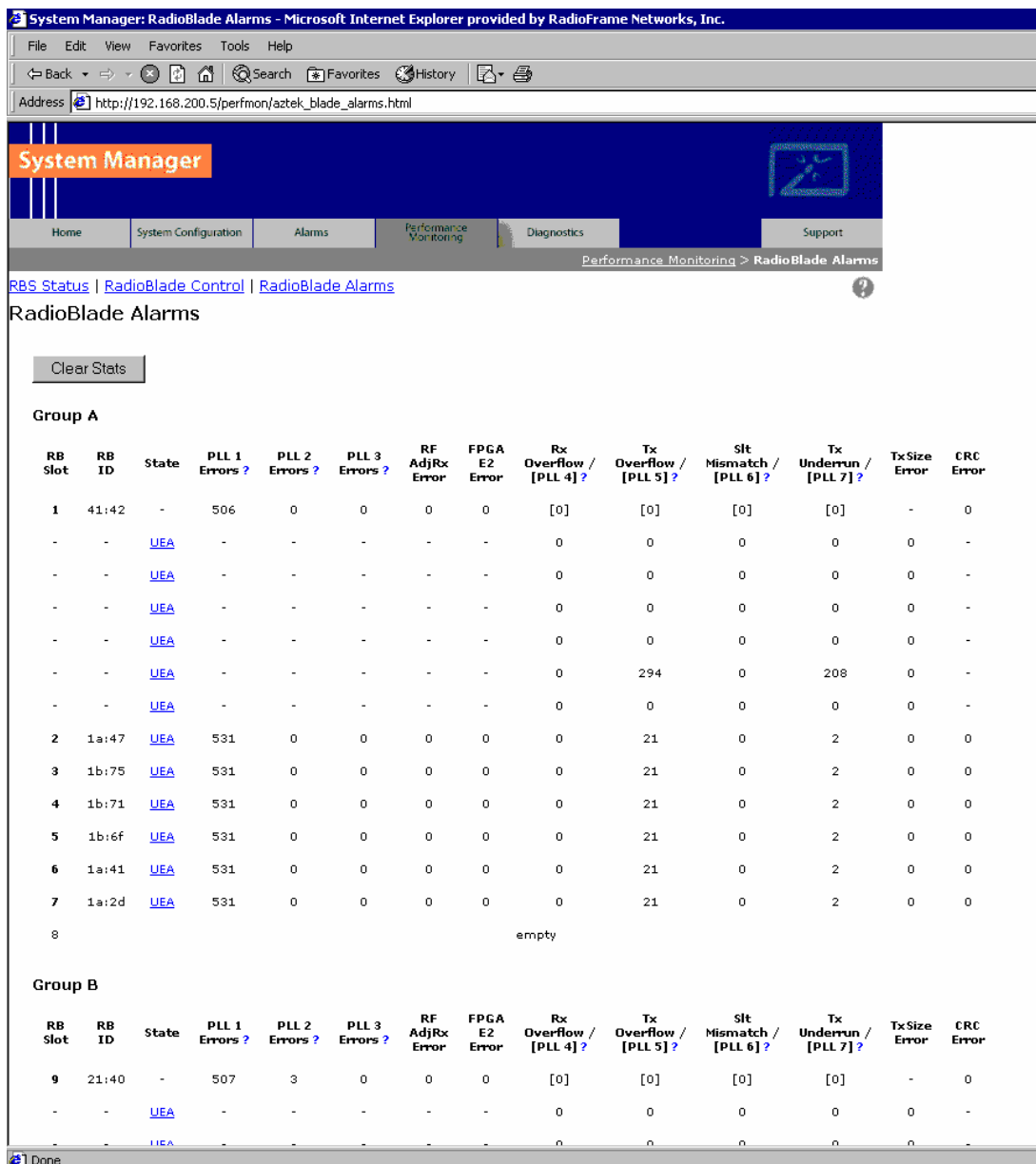

6.2.2.5 Changing the Device Name, IP Address or Building Location

The System Configuration page displays the configuration for the selected component (BIC, AIC and RBS) including the Device Name, IP Address and Building Address—this information can be changed at any time. For the BIC, this page also displays External IP Configuration, the information that systems outside the MC-Series system use to recognize it, including the Default Gateway (the IP address of the CSU).

- 1 Select the icon of the component to be changed.
- 2 For Device Name, enter up to 31 alphanumeric characters to uniquely identify the component.

- 3 The IP Address is assigned during the installation of the MC-Series system, and doesn't need to be changed.
- 4 For Building Address, enter up to 3,000 alphanumeric characters specifying the location of the component. Enter information such as the street address, mailing address, building and other site information, as well as the building floor, Telco closet and cabinet location.
- 5 Select Save Changes.

Figure 46 System Configuration Page, BIC Selected Component



6.2.2.6 Viewing Hardware and Software Versions

Select the **Software Version Information** link on the System Configuration page. The Software Version Information page depicts each component in the MC-Series system, and each board installed in each component. For each board the page lists:

- MAC—the MAC address
- HW—hardware version
- FPGA—Field Programmable Gate Array version (manufacturer defined)
- ROM—software loaded at time of shipment
- SW Selected—currently selected software version, A or B
- SW Loaded—currently loaded software version, A or B
- SW Versions A—Software version loaded in partition A
- SW Versions B—Software version loaded in partition B

Figure 47 Software Version Information Page



6.2.2.7 Changing the iDEN Configuration

The MC-Series system operates as a series of base radios. Each RadioBlade transceiver in the MC-Series is assigned a BR ID and sector (1, 2 or 3). And, each BR in the MC-Series system is assigned a default cabinet position in the site datafill.

To change the default cabinet position:

- 1 Select the **iDEN Configuration** link at the bottom of the System Configuration tab.
- 2 Enter the **Cabinet** and **Position** for the specified BR(s).
- 3 Select any **Quad BRs** (only one per group), according to site datafill parameters.
- 4 In Figure 48, one Quad BR has been selected: **BR Instance 5 Cabinet 3 Position 5**, in the first group. In this example, BRs 5 through 8 make up the Quad BR.
- 5 Select the **Save Changes** button to save the changes.

Figure 48 iDEN Configuration Page

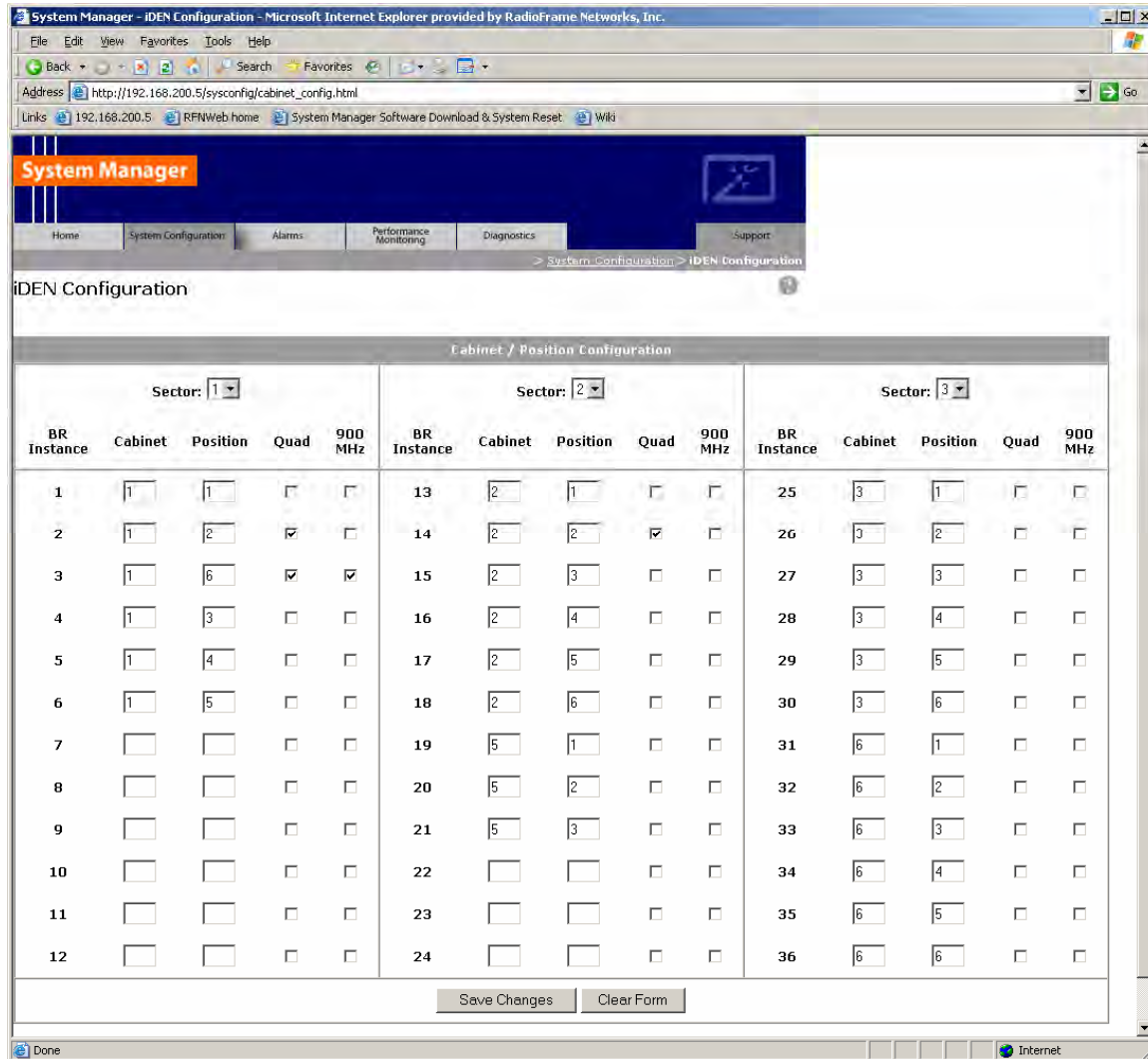

6.2.3 Optimization Procedures

6.2.3.1 Local Performance Monitoring

- 1 In System Manager, select the Performance Monitoring tab.

Figure 49 Operational Status—Performance Monitoring Page

System Manager

Home | System Configuration | Alarms | Performance Monitoring | Diagnostics | Support

> iDEN Performance Monitoring

[RBS Status](#) | [RadioBlade Control](#) | [RadioBlade Alarms](#)

iDEN Performance Monitoring

Number of System Interconnect Setups: 0

Number of System Dispatch Setups: 0

Number of System Interconnect LOTS: 0

Number of System Dispatch LOTS: 0

Number of System Percent LOTS: 0.00%

iSC Version: 13.00

bCRIC UpTime: 00:04:11

Time since last reset: 00:04:11

Group A	Group B	Group C
Interconnect Setups: 0 Dispatch Setups: 0 Interconnect LOTS: 0 Dispatch LOTS: 0 Percent LOTS: 0.00%	Interconnect Setups: 0 Dispatch Setups: 0 Interconnect LOTS: 0 Dispatch LOTS: 0 Percent LOTS: 0.00%	Interconnect Setups: 0 Dispatch Setups: 0 Interconnect LOTS: 0 Dispatch LOTS: 0 Percent LOTS: 0.00%
BR ID: 1 Cabinet: 1 Position: 1 External MAC: 00:03:e0:a9:0b:81 Carrier ID: 1 -800MHz Activity State: UEA (00:00:37) Tx Power: 8.4	BR ID: 2 Cabinet: 2 Position: 1 External MAC: 00:03:e0:a9:15:85 Carrier ID: 3 -800MHz Activity State: UEA (00:00:37) Tx Power: 8.4	BR ID: 3 Cabinet: 3 Position: 1 External MAC: 00:03:e0:a9:1f:81 Carrier ID: 5 -800MHz Activity State: UEA (00:00:40) Tx Power: 8.4
BR ID: 4 5 6 Cabinet: 1 Position: 2 External MAC: 00:03:e0:a9:0c:82 Carrier ID: 1 3 5 -900MHz Activity State: UEA (00:00:37) Tx Power: 8.4	BR ID: 7 8 9 Cabinet: 2 Position: 2 External MAC: 00:03:e0:a9:16:86 Carrier ID: d f 11 -900MHz Activity State: UEA (00:00:37) Tx Power: 8.4	BR ID: 10 11 12 Cabinet: 3 Position: 2 External MAC: 00:03:e0:a9:20:82 Carrier ID: 1b 1d 1f -900MHz Activity State: UEA (00:00:40) Tx Power: 8.4
BR ID: 13 14 15 Cabinet: 1 Position: 3 External MAC: 00:03:e0:a9:0d:83 Carrier ID: 169 16b 16d -800MHz Activity State: UEA (00:00:37) Tx Power: 8.4	BR ID: 16 17 18 Cabinet: 2 Position: 3 External MAC: 00:03:e0:a9:17:87 Carrier ID: c7 c9 cb -800MHz Activity State: UEA (00:00:37) Tx Power: 8.4	BR ID: 19 20 21 Cabinet: 3 Position: 3 External MAC: 00:03:e0:a9:21:83 Carrier ID: 183 185 187 -800MHz Activity State: UEA (00:00:40) Tx Power: 8.4
BR ID: 22 Cabinet: 1 Position: 4 External MAC: 00:03:e0:a9:0e:84 Carrier ID: 289 -800MHz Activity State: UEA (00:00:37) Tx Power: 8.4	BR ID: 23 Cabinet: 2 Position: 4 External MAC: 00:03:e0:a9:18:88 Carrier ID: 28b -800MHz Activity State: UEA (00:00:37) Tx Power: 8.4	BR ID: 24 Cabinet: 3 Position: 4 External MAC: 00:03:e0:a9:22:84 Carrier ID: 28d -800MHz Activity State: UEA (00:00:40) Tx Power: 8.4
BR ID: 25 Cabinet: 1 Position: 5 External MAC: 00:03:e0:a9:0f:85 Carrier ID: 361 -800MHz Activity State: UEA (00:00:37) Tx Power: 8.4	BR ID: 26 Cabinet: 2 Position: 5 External MAC: 00:03:e0:a9:19:81 Carrier ID: 363 -800MHz Activity State: UEA (00:00:37) Tx Power: 8.4	BR ID: 27 Cabinet: 3 Position: 5 External MAC: 00:03:e0:a9:23:85 Carrier ID: 365 -800MHz Activity State: UEA (00:00:40) Tx Power: 8.4
BR ID: 28 Cabinet: 1 Position: 6 External MAC: 00:03:e0:a9:10:86 Carrier ID: 439 -800MHz Activity State: UEA (00:00:37) Tx Power: 8.4	BR ID: 29 Cabinet: 2 Position: 6 External MAC: 00:03:e0:a9:1a:82 Carrier ID: 43b -800MHz Activity State: UEA (00:00:37) Tx Power: 8.4	BR ID: 30 Cabinet: 3 Position: 6 External MAC: 00:03:e0:a9:24:86 Carrier ID: 43d -800MHz Activity State: UEA (00:00:40) Tx Power: 8.4
BR ID: 31 Cabinet: 4 Position: 1 External MAC: 00:03:e0:a9:29:87 Carrier ID: 511 -800MHz Activity State: UEA (00:00:37) Tx Power: 8.4	BR ID: 32 Cabinet: 5 Position: 1 External MAC: 00:03:e0:a9:33:83 Carrier ID: 513 -800MHz Activity State: UEA (00:00:37) Tx Power: 8.4	BR ID: 33 Cabinet: 6 Position: 1 External MAC: 00:03:e0:a9:3d:87 Carrier ID: 515 -800MHz Activity State: UEA (00:00:40) Tx Power: 8.4
BR ID: 34 Cabinet: 4 Position: 2 External MAC: 00:03:e0:a9:2a:88 Carrier ID: 5e9 -800MHz Activity State: UEA (00:00:37) Tx Power: 8.4	BR ID: 35 Cabinet: 5 Position: 2 External MAC: 00:03:e0:a9:34:84 Carrier ID: 5eb -800MHz Activity State: UEA (00:00:37) Tx Power: 8.4	BR ID: 36 Cabinet: 6 Position: 2 External MAC: 00:03:e0:a9:3e:88 Carrier ID: 5ef -800MHz Activity State: UEA (00:00:40) Tx Power: 8.4

00:00:50 JAN 01 > iDEN Performance Monitoring

- 2 Select a BR icon to display the **Base Radio Performance Statistics** page.
- 3 Verify that the mean INI is within normal range (will vary depending on what is connected between TOR and the antenna).
- 4 Verify that the % poor SQE does not exceed 2% on a substantial number of packets (i.e., greater than 10,000 packets).
- 5 Repeat steps 2 through 4 for each BR in the system.

Figure 50 Base Radio Performance Statistics Page

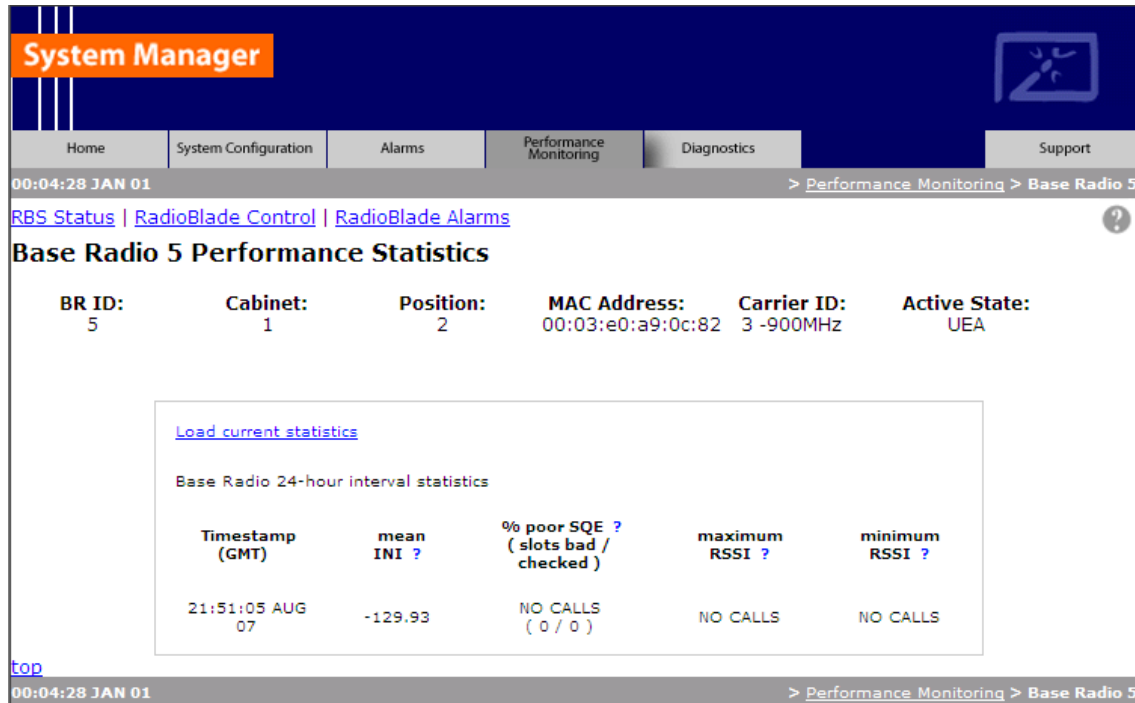

6.2.3.2 iDEN Uplink Analysis

RadioFrame Networks' iDEN Uplink Analysis Tool plots the Mean RSSI, Mean I+N and SQE for the last 80 seconds for the BR channel which has been selected. Figure 51 shows the System Manager page, accessible from the Diagnostics tab. The analyzer prints the following information:

- Mean RSSI (red): Average Received Signal Strength Indicator.
- Mean I+N (magenta): Average Interference Plus Noise.
- SQE (yellow): Signal Quality Estimate.

Figure 51 Uplink Analyzer Page

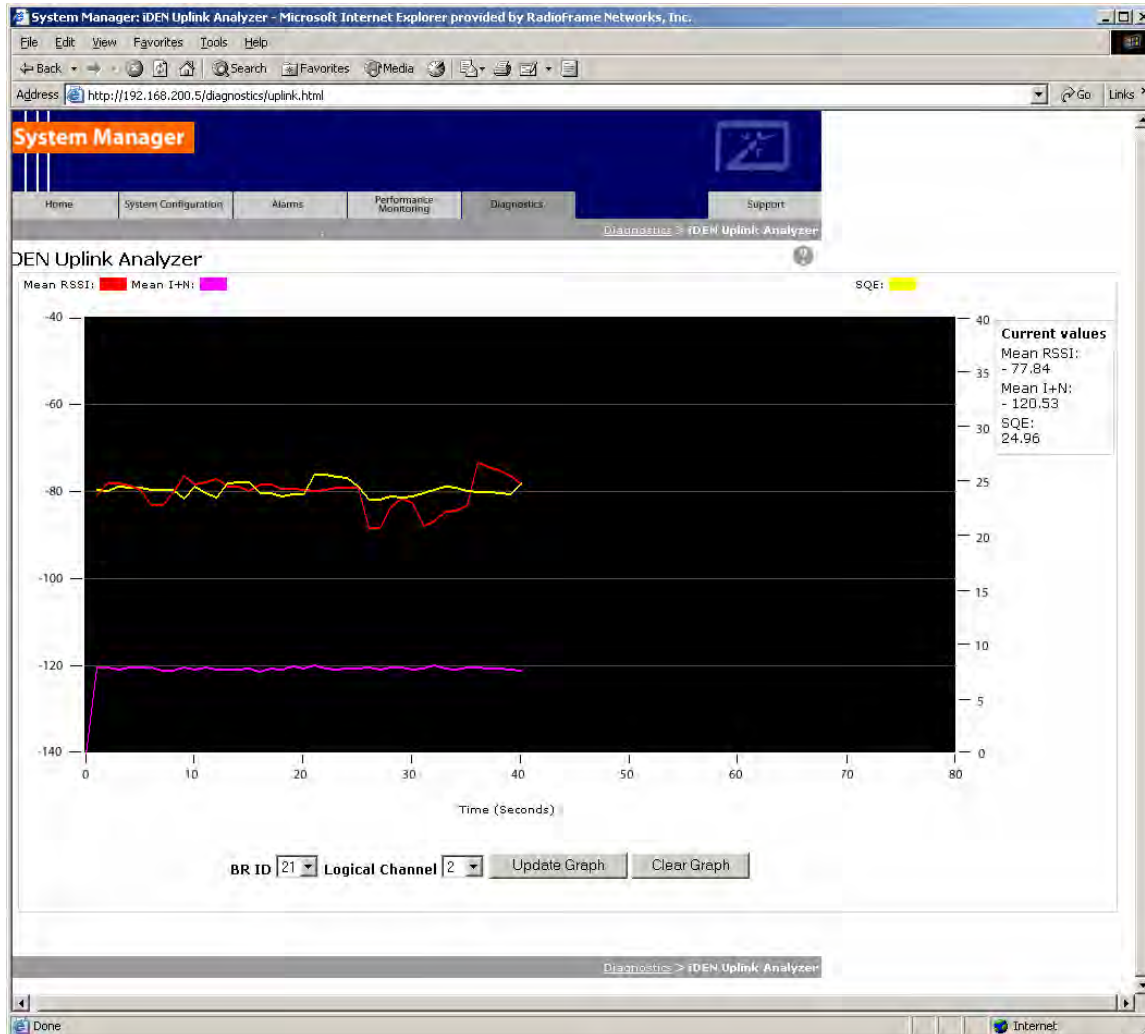

To use the Uplink Analysis Tool:

- 1 Select a radio and channel:
 - Select the base radio from the BR ID menu. Select the channel from the Logical Channel menu.
 - Click Update Graph to clear the screen and start a new graph with the new radio and channel.
 - Click Clear Graph to reset the graph and start fresh with the current base radio and channel.
- 2 Reset the graph by clicking Clear Graph, and start fresh with the current base radio and channel.

6.2.3.3 Voice Loopback Diagnostic Test

The Voice Loopback Diagnostic test provides the ability to loop all inbound voice traffic back out on the same logical channel for a given BR. This allows a person with a mobile to do uplink and downlink testing on a given BR without having to call someone else to

monitor voice quality. The person on the Mobile simply speaks into the mobile and can hear his or her own voice.

To use the Voice Loopback Test feature:

- 1 Click Start Test on the Voice Loopback Diagnostic Test Page to start the voice packet loopback. The first call, and only the first call, set up after Start Test is selected will be looped back. If a call other than the tester's happens to be set up after Start Test is selected and before the tester has the opportunity to set up the call, the other call will be looped back.

Figure 52 Voice Loopback Diagnostic Test Page

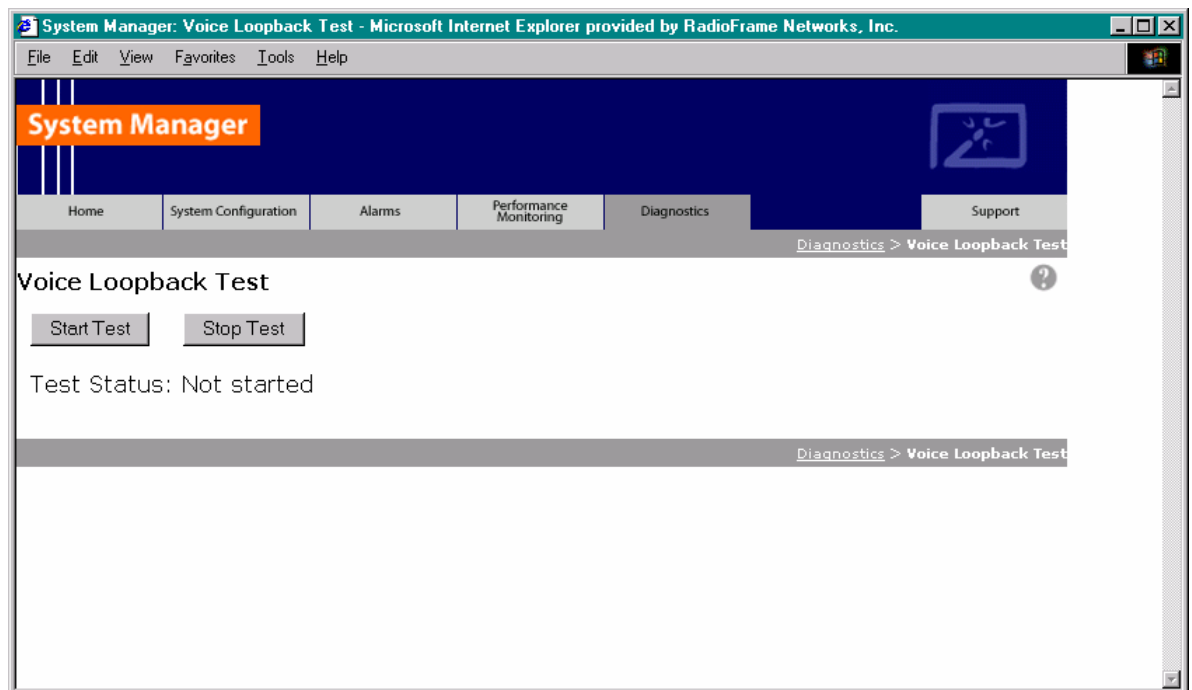

- 2 Speak into the handset, and listen to evaluate voice quality.
- 3 Click Stop Test to terminate the test.

The loopback will persist on the selected BR until the Stop Test button is selected.

The Test Status line will give a brief indication of the test state (Not Started; Waiting for Call Setup; Started).

6.2.3.4 System Parameter Information Page

The System Parameter Information Page displays the type 1 iDEN System Parameter Information that comes across the BCCH chain.

Note: Only a subset of the BCCH information is currently displayed.

Figure 53 System Parameter Information Page

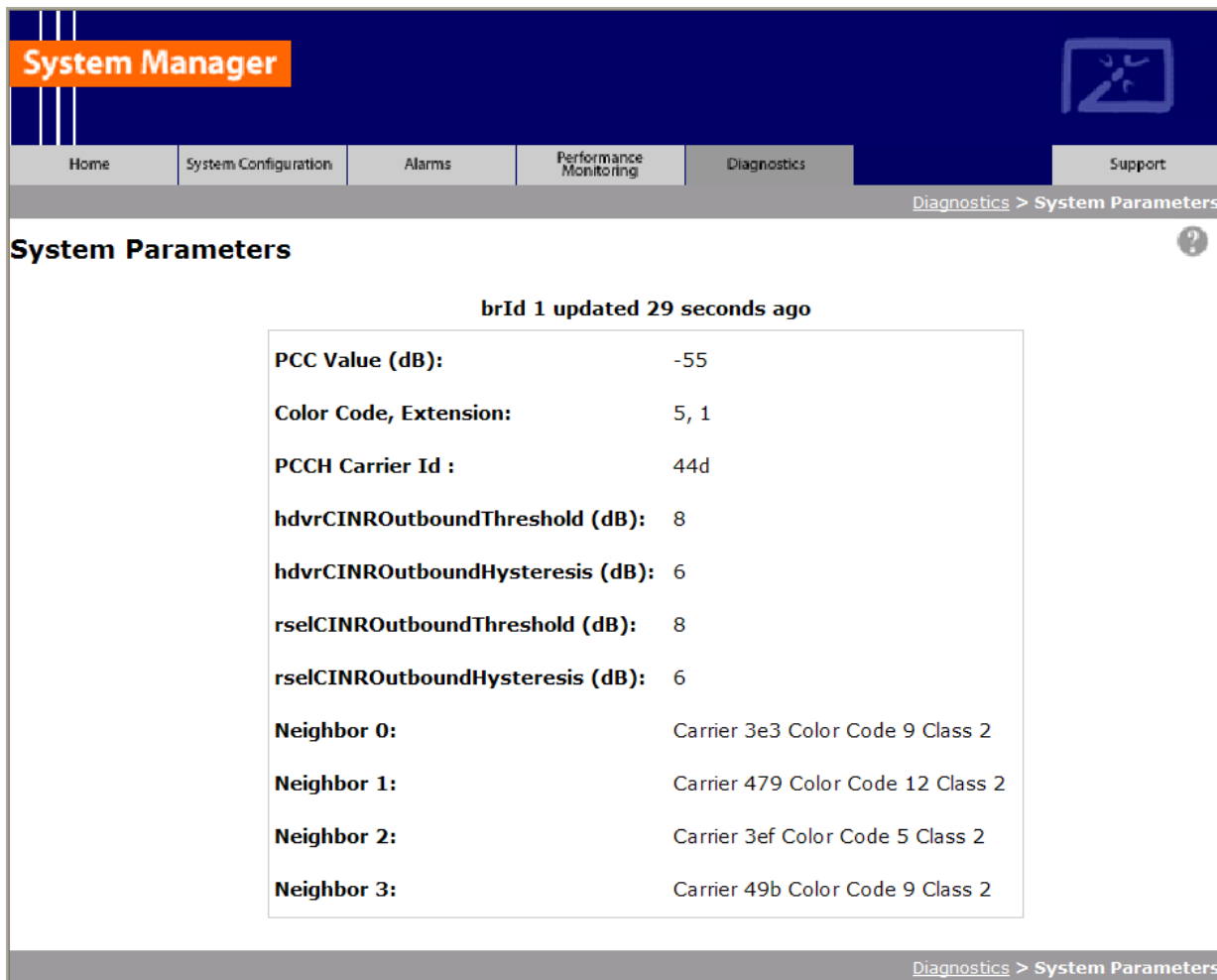

Note: The datafill parameters “hdvrCINROutboundThreshold” and “rconCINROutboundThreshold” are modified in the iSC per the iDEN specification. The value displayed as “rse1_threshold” in the System Parameter Information page reflects the observed BCCH value, which is the datafill value of “rconCINROutboundThreshold”, offset by + 14 dB. The value displayed as “hdvr_threshold” is the datafill value “hdvrCINROutboundThreshold”, offset by + 14 dB. For example, in the screen shot shown in Figure 53, the datafill value corresponding to “hdvr_threshold” would be equal to 6 (i.e., 6 +14 = 20).

System Manager is the MC-Series system web-based interface. System Manager provides status, performance, and alarm information for the MC-Series system and its components, as well as diagnostic tools and online help. When new releases of System Manager are provided, download the new release as described in section 8.1 “Upgrading MC-Series System Software”.

If any of the following information is changed in System Manager, also note those changes on the Equipment Inventory or site as-built documentation:

- Physical location
- IP addresses

- Port connections
- Sector locations

7 Scheduled and Unscheduled Maintenance

7.1 Maintenance

A report of the MC-Series Medium Power system should be maintained and left on site. This report will provide metrics for possible concerns with individual components and/or the entire system. It is important that the technician performing the checks understand the equipment theory and operation. Review the documentation (references) prior to verification and performing service.

For non-RFN hardware, refer to the equipment manufacturer's documentation for maintenance information and procedures. For the iSC-3s and the EAS, refer to the *Gen 3 Site Controller System Manual*, Motorola, 68P80801E30-O. For the CSU, refer to the manufacturer's documentation for preventive maintenance information.

7.2 Annual Maintenance

Conduct the following **annual maintenance**:

- Visually inspect all equipment in the MC-Series Medium Power system cabinet for loose or foreign items and for visible damage.
- Verify site-configuration cabling is correct. Refer to cabling diagrams in Appendix C.
- Conduct the BER test on each RadioBlade transceiver. Refer to Appendix F "BER Test Procedure".
- Conduct the TOR Tx measurement (RF output measurement) on each transmitter.

7.3 Troubleshooting Guidelines

Technicians should conduct the following troubleshooting steps in order:

- 1 Visually inspect for fault indication (LEDs).
- 2 Inspect the Alarm Manager, and follow alarm resolution procedures. Refer to the Alarm and Event Guide as well as sections 7.5 "System Manager Alarms" and 7.6 "RadioBlade Transceiver Alarm Handling" of this Implementation Guide.
- 3 Contact the RadioFrame Networks Technical Assistance Center at: (800) 328-0847. Also, refer to section 1.3, "Repair and Technical Support" on page 12.
- 4 Complete and save the serial log upload if directed; refer to section 7.7 "Serial Log Upload Procedure".
- 5 Refer to sections 7.8, "Power Down Procedure" and 7.9, "Field Replaceable Unit (FRU) Procedures" as necessary.

7.4 Fault Indications

This section provides fault indications for the following RadioFrame Networks components only: BIC, AIC, RBS and RF Shelf. For all non-RFN equipment, refer to Sprint Nextel's or the manufacturer's documentation.

7.4.1 BIC

Table 23 BIC LED Indications

LED	Indication	Condition	Corrective action
POWER	green	normal condition	none
	not lit	no power to BIC	Verify that BIC circuit breaker on PDU is ON. Check power connection to PDU. Measure power input, and compare with tolerances listed in section 2 "Specifications". Verify that the power source is operational. Contact the TAC: (800) 328-0847
STATUS	green	normal condition	none
	not lit	card(s) not receiving power	Verify power to BIC (see "no power to BIC" above)
	red <i>CRIC only</i>	bootup not complete	Allow three minutes (approx.) for bootup to complete.
		timing not synchronized	Verify that the GPS LED on iSC-3 is green. Verify that the cable is connected from BIC ERTM port 5MHz/1PPS IN to iSC-3 port 5MHz/1PPS. Contact the TAC: (800) 328-0847
	red <i>any card</i>	PLLs are not locked	Verify that the STATUS LED on the BIC CRIC is green Check the Alarm Manager for PLL LOCK alarm; wait 3 minutes for PLLs to lock; if they do not: Verify integrity of Ethernet connection between BIC and AIC. Contact the TAC: (800) 328-0847

7.4.2 AIC

Table 24 AIC LED Indications

LED	Indication	Condition	Corrective action
POWER	green	normal condition	none
	not lit	no power to AIC	Verify that AIC circuit breaker on PDU is ON. Check power connection to PDU. Measure power input, and compare with tolerances listed in section 2.5 "Specifications". Verify that the power source is operational. Contact the TAC: (800) 328-0847
STATUS	green	normal condition	none
	not lit	card(s) not receiving power	Verify power to AIC (see "POWER" above)
	red	PLLs are not locked	Verify that the STATUS LED on the BIC CRIC is green Check the Alarm Manager for PLL LOCK alarm; wait 3 minutes for PLLs to lock; if they do not: Verify integrity of Ethernet connection between BIC and AIC. Contact the TAC: (800) 328-0847

7.4.3 RBS

Table 25 RBS LED Indications

LED	Indication	Condition	Corrective action
STATUS	green	normal condition	none
	not lit	no power to RBS	Verify that RBS circuit breaker on PDU is ON. Check power connection to PDU. Measure power input, and compare with tolerances listed in section 2.5, "Specifications". Verify that the power source is operational. Contact the TAC: (800) 328-0847
	red	timing is not synchronized to the group (A, B, or C) Board unable to boot	Power cycle the RBS using the circuit breaker on the PDU. Contact the TAC: (800) 328-0847

LED	Indication	Condition	Corrective action
RADIOBLADE TRANSCEIVER STATUS	green	RadioBlade transceiver present and operational	none
	not lit	RadioBlade transceiver not present	none
		RadioBlade transceiver present	Reseat RadioBlade transceiver.
	red	RadioBlade transceiver is in error state	Reseat RadioBlade transceiver. If still red, replace RadioBlade transceiver.

7.4.4 RF Shelf

Table 26 RF Shelf LED Indications

LED	Indication	Condition	Corrective action
POWER	green	normal condition	none
	not lit	no power to RF shelf	Verify that RF circuit breaker on PDU is ON. Check power connection to PDU. Measure power input, and compare with tolerances listed in section 2.5, "Specifications". Verify that the power source is operational. Contact the TAC: (800) 328-0847
ALARM	green	normal condition	none
	not lit	not receiving power	Verify power to RF Shelf (see "POWER" above).
	red	alarm condition	Check the Alarm Manager for: RF SHELF MINOR, replace fan. RF SHELF MAJOR, replace RF shelf. Contact the TAC: (800) 328-0847

7.5 System Manager Alarms

The MC-Series system provides fault alarming and isolation within System Manager for individual components, which consists of detecting catastrophic faults that prevent a component from responding to a periodic "ping". Depending on the severity, alarms are sent to the OMC via the iSC-3.

The *Alarms/Events Reference Guide*, included on the MC-Series CD and available on the RadioFrame Networks website, lists the alarms by ID code.

All alarms passed to the OMC use the Sprint Nextel Alarm Code 35009, which uses the event description "Unable to key BR".

7.5.1 Viewing System Manager Alarms

- 1 Select the Alarms tab in System Manager to display the Active Alarm Manager.

The Alarm Log displays active (un-cleared) alarms listed by date and time, and the Alarm Details window displays information about a single selected alarm (see

Figure 54). A summary at the top of the page lists the current number of Critical, Major, Minor, and Warning alarms. Alarms that are no longer active are moved to the Alarm History Manager.

Note: If the Alarms page is empty, System Manager is still loading the page.

Non-alarm events are displayed in the Events Log. The initial Events Log lists all the alarms generated by RFS components. You can view a smaller list by selecting one of the Show links at the bottom of the page. Clicking the first link with a value of 20 in the box displays the first 20 alarms. You can enter any number in the field.

Figure 54 Alarm Log Page

System Manager

Home System Configuration **Alarms** Performance Monitoring Diagnostics Support

23:46:32 NOV 18 > Active Alarm Manager

Active Alarm Manager

[Alarm History](#)
[Event Log](#)

Critical: 3 Major: 3 Minor: 13 Warning: 0

Alarm Log

Details Link	Timestamp	Affected Service	Perceived Severity	Probable Cause	Specific Problem	Base Radio Transceiver
Details	23:28:28 NOV 18	iden	minor	Equipment malfunction	Lost comm with iDEN radio blade	11
Details	23:28:28 NOV 18	iden	minor	Equipment malfunction	Lost comm with iDEN radio blade	9
Details	23:28:28 NOV 18	iden	minor	Equipment malfunction	Lost comm with iDEN radio blade	13
Details	23:28:28 NOV 18	iden	minor	Equipment malfunction	Lost comm with iDEN radio blade	12
Details	23:28:28 NOV 18	iden	minor	Equipment malfunction	Lost comm with iDEN radio blade	10
Details	23:28:30 NOV 18	asp	major	Network error	RFU and corresponding RBs lost	n/a
Details	23:28:37 NOV 18	iden	minor	Equipment malfunction	Lost comm with iDEN radio blade	17
Details	23:28:37 NOV 18	iden	minor	Equipment malfunction	Lost comm with iDEN radio blade	20
Details	23:28:37 NOV 18	iden	minor	Equipment malfunction	Lost comm with iDEN radio blade	19

Alarm Details

Alarm Type	Eqt Chassis	Eqt Rfu/Rbs	Eqt Slot	Eqt Type	Eqt Mac	System Reaction	Further Repair Actions	State Change	Additional Info
communication	aic	grpB	n/a	rbs	0x00:03:e0:50:00:01	System reset	Err No 0000007 - Refer Help	false	0xc0a8c863

Table 27 Alarm Log Fields

Alarms Log Field	Description
Details	Displays details of the alarm in the Alarm Details window
Timestamp	Date and time alarm occurred (in Greenwich meantime-GMT)
Affected Service	iden: iDEN software only asp: platform software only rfn: All system software is affected (platform, iDEN)
Perceived Severity	cleared: A 'set' alarm has been cleared and moved to Alarm History critical : Service affecting failure; requires immediate attention major : Service affecting degradation; requires urgent attention minor: Non-service affecting condition; requires scheduled attention warning: Potential condition that may lead to a more serious alarm
Probable Cause	Describes what might have caused the alarm
Specific Problem	Describes the problem more specifically
Base RadioTransceiver	BR ID (1 through 32) or n/a for not applicable

2 To view details about a specific alarm, select the **Details** link next to the alarm. The **Alarm Details** window displays the information listed in Table 28.

Table 28 Alarm Details Fields

Alarm Details Field	Description
Alarm Type	Communication : failure to convey information Quality of service : signal degradation Processing error: software processing fault Equipment: equipment fault Environmental: condition with the equipment enclosure
Eqpt Chassis	Affected chassis: bic or aic
Eqpt Rfu/Rbs	Affected RBS group: grp A, grp B, or grp C
Eqpt Slot	Affected chassis slot: BIC (1-5), AIC (1-5), or RBS (1-24)
Eqpt Type	rfn: unknown rlc: BIC CRIC bpc: BPC or BPC+SPAM ric: AIC CRIC rbs: RBS idenrb: RadioBlade transceiver
Eqpt Mac	MAC address of the affected component
System Reaction	The action taken by the system as a result of the alarm
Further Repair Actions	Corrective action that should be taken as a result of the alarm
State Change	Not currently used (displays 'false' by default)
Additional Info	Miscellaneous 32-bit field

7.5.2 OMC Alarm Code

All RFS MC-Series alarms sent to the OMC use the Sprint Nextel Alarm Code 35009. Table 29 shows the properties for this alarm code. The Event Description for this alarm is 'Unable to key BR'.

Table 29 Alarm Code 35009 Properties

Event	Description
Sprint Nextel Alarm Code	35009
Event Type	CntrlBrd
Alarm Type	Equipment Failure
Actionable	Yes
Severity	Minor, Major or Critical
Bounce Threshold (x)	3
Bounce Threshold Minutes	30
Duration Threshold	10
Related Alarms	None
R & C	RC
Outage Y/N	S1_EI CY
Event Description	Unable to key BR
Advisor	Site Service call
Comments	None
Alert Names	BREFCTLBD35009
Last updated	8/3/2001
Revision	
Change Notes	8/3/2001: per new EBTS rules baseline. Changed severity and threshold from GR1 to: Severity=minor BounceThreshold=3 Bounce Threshold Minutes=30 Duration Threshold=10
Action	Create trouble ticket. Contact Field Technician. TS/BR

7.5.3 System Manager Alarms

The document *Alarms/Events Reference Guide* lists MC-Series system alarms numerically by alarm ID (0x01, 0x02, etc.).

MC-Series alarms are based on the X.733 conventions for telecommunications equipment. The alarms are grouped by service: either “asp” for platform faults or “iden” for iden application faults. The “cause” field contains the X.733 cause type. “System reaction” describes the action taken by the system as a result of this alarm, and “repair actions” provides details on what corrective action should be taken as a result of this alarm.

The Alarm details on the active alarm manager page of System Manager provides additional information with respect to the board, slot number, MAC address and equipment type.

7.6 RadioBlade Transceiver Alarm Handling

The iDEN RadioBlade transceivers track various faults and reports to the RadioBlade controller. These faults are monitored, and if the rate at which these faults occur surpasses a threshold, the RadioBlade transceiver (blade) is locked. The blade will generate these faults as the result of normal actions such as re-syncing the blade, locking and unlocking the blade and locking and unlocking the BR. For these reasons, only if the blade continues to generate these faults under normal operating circumstances is an alarm generated.

The RadioBlade transceiver tracks the faults listed in Table 30.

Table 30 Faults Tracked by the Transceiver

Fault	Description
PLL1 Errors	The Phase Lock Loop #1 went out of lock.
PLL2 Errors	The Phase Lock Loop #2 went out of lock.
PLL3 Errors	The Phase Lock Loop #3 went out of lock.
Tx Underrun	RadioBlade transceiver did not receive a packet in time to transmit.
Tx Overflow	RadioBlade transceiver received too many packets to transmit.
Rx OverFlow	Sample buffer overflowed.
Slot mismatch	Received packets were not consecutive.
CRC errors	Received Ethernet packets had CRC errors.

If a RadioBlade transceiver generates enough errors such that it crosses the Bounce and Duration threshold for that particular error, an alarm will be generated. This alarm will also cause the RadioBlade Locking Policy to lock that RadioBlade transceiver. Table 31 lists the fault count and fault period for an alarm to be generated.

Table 31 RadioBlade Transceiver Fault Thresholds for Alarm Generation

Alarm	Bounce Threshold (counts)	Duration Threshold (minutes)
PLL 1	75	12
PLL 2	75	12
PLL 3	50	12
Tx Underrun	40	12
Tx Overflow	40	12
Rx Overflow	40	12
Slot Mismatch	40	12
CRC Errors	20	12
Packet Size Errors	20	12

In addition to the above-mentioned errors, if the system loses communication with a RadioBlade transceiver or is unable to read the EEPROM from the blade, then that blade is put into an error state and if a standby blade is available it will switch over automatically.

7.6.1 RadioBlade Locking Policy

The RadioBlade locking policy defines the actions taken by the system when a determination is made that a RadioBlade transceiver should no longer be allowed to remain active. This could be the result of an alarm, insertion, removal or intervention (the user specifically locking the RadioBlade transceiver).

In general, the policy is that if a blade is taken out of service and a standby RadioBlade transceiver is available, then the standby RadioBlade transceiver will go into service. If no standby RadioBlade transceiver is available then the associated BR(s) will be locked. (For the Multi-Channel RadioBlade transceiver, the locking event locks all carriers.)

The RadioBlade locking policy is enabled by default and in effect at all times.

7.6.1.1 Standby Blade

A Standby Blade is an extra RadioBlade transceiver that is installed in the system but does not have a configured BR with which to register. To setup Standby Blades, make sure that there are more RadioBlade transceivers for each RBS Group than Base Radios configured in the iDEN configuration page.

In all the conditions described below, if RadioBlade transceivers are present in the system that are in the hot-standby state, then locking the RadioBlade transceiver (due to alarms, removal of a RadioBlade transceiver or administratively locking RadioBlade transceivers) will result in the hot Standby Blade transceiver being assigned to the BR that de-registered the locked RadioBlade transceiver.

7.6.1.2 Locking Policy for RadioBlade Transceiver with Errors

If the RadioBlade transceiver generates enough faults such that it crosses the Bounce and Duration threshold for that particular error, an alarm will be generated. The RadioBlade controller then notifies the associated BR, which then locks the RadioBlade transceiver. This will result in disabling the BR.

If there is a faulty RadioBlade transceiver in the system (generating error alarms), it is prevented from coming up after a commanded reset/system reset, but the operator could manually unlock the RadioBlade transceiver, at which point the RadioBlade transceiver would be assigned to a BR. (This would not prevent the system from locking it again if an excessive error condition recurs).

7.6.1.3 Removal of RadioBlade Transceiver

When a RadioBlade transceiver is physically removed, an event is generated in the System Manager Event Log notifying the user about the RadioBlade transceiver removal. The RadioBlade controller will then de-register the RadioBlade transceiver from the BR(s), which will result in locking the BR(s).

A RadioBlade transceiver Insert event is generated when the RadioBlade transceiver is inserted into the system.

7.6.1.4 Administrative Locking of a RadioBlade Transceiver

By definition, administrative locking of a RadioBlade transceiver is in effect if the RadioBlade transceiver lock icon on the RadioBlade Transceiver Status page is changed to "locked".

The Multi-Channel RadioBlade transceiver is treated as a unit (single RBID) with respect to administrative locking.

The following rules apply to locking a RadioBlade transceiver.

- The BR(s) associated with the administratively locked RadioBlade transceiver will go into a Disabled state. Only that RadioBlade transceiver will lock, and its icon will change to “locked”.
- If an administratively locked RadioBlade transceiver is replaced, the new RadioBlade transceiver will be considered unlocked upon insertion. (Administrative locking applies to a particular RadioBlade transceiver and not to a particular RBS Slot).
- Upon unlocking an administratively locked RadioBlade transceiver, the BR that was previously disabled due to the locked state will go into the enabled state.

The lock policy will be preserved through a system reset. Locking of the RadioBlade transceiver will also be preserved through a system reset. Locking of RadioBlade transceivers in the disabled state will not be preserved through a system reset. However, after a system reset, those blades that were originally in the disabled state due to the effects of a) the locked RadioBlade transceiver and b) the locking policy will likely return to the disabled state.

The RadioBlade Control page of System Manager has a “Lock All / Unlock All” feature. Refer to Figure 55. Selecting the padlock icon for a two-port RadioBlade (RBD2) transceiver locks the blade. With an MCRB, locking the top padlock as shown on the RadioBlade Control page will lock all carriers for that MCRB while selecting the padlock on the individual carrier will lock only that carrier.

Figure 55 System Lock All / Unlock All Feature

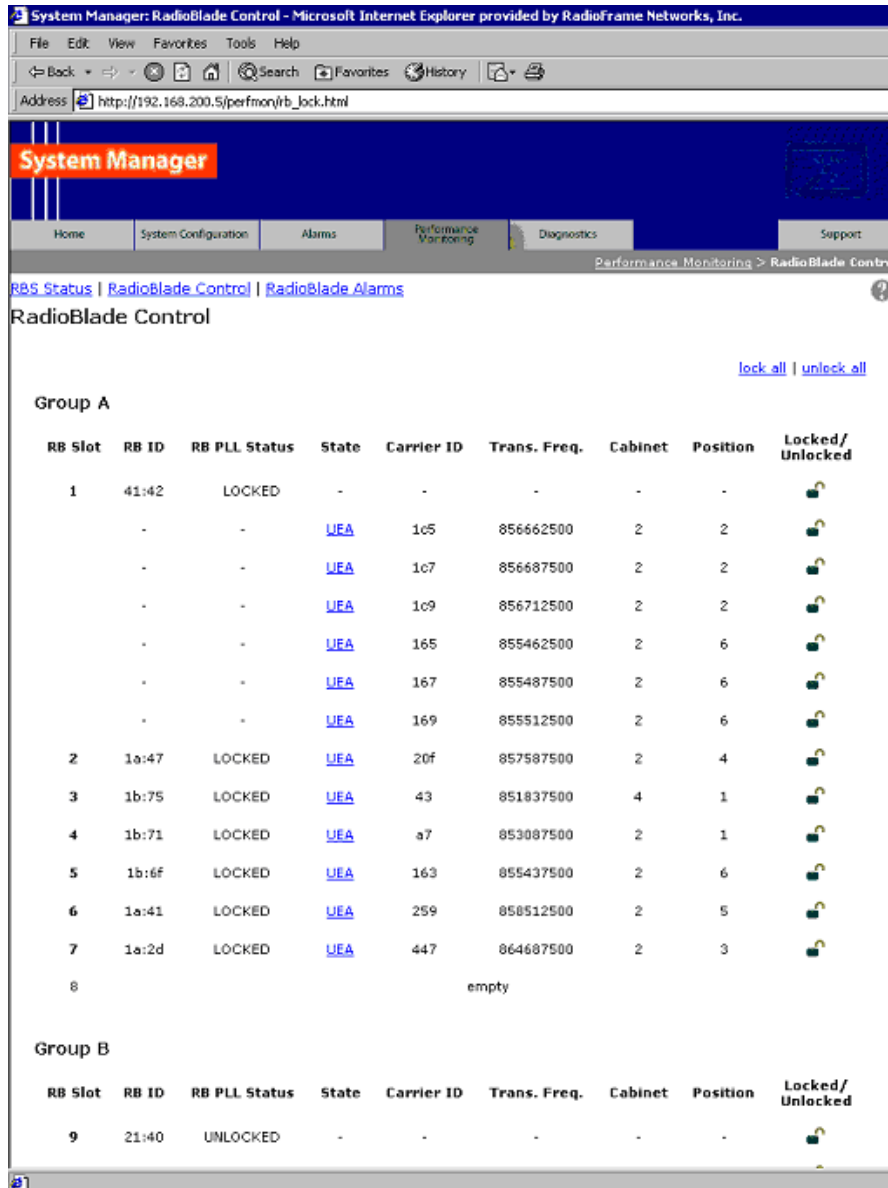

7.7 Serial Log Upload Procedure

Complete this procedure before disconnecting and removing the BIC, AIC, RBS or an RF shelf from the MC-Series system rack, or at the direction of RadioFrame Networks technical support.

- 1 Select the **Diagnostics** tab in System Manager, and then select the **Serial Log Upload** link.

Figure 56 Serial Log Upload Link, Diagnostics Tab

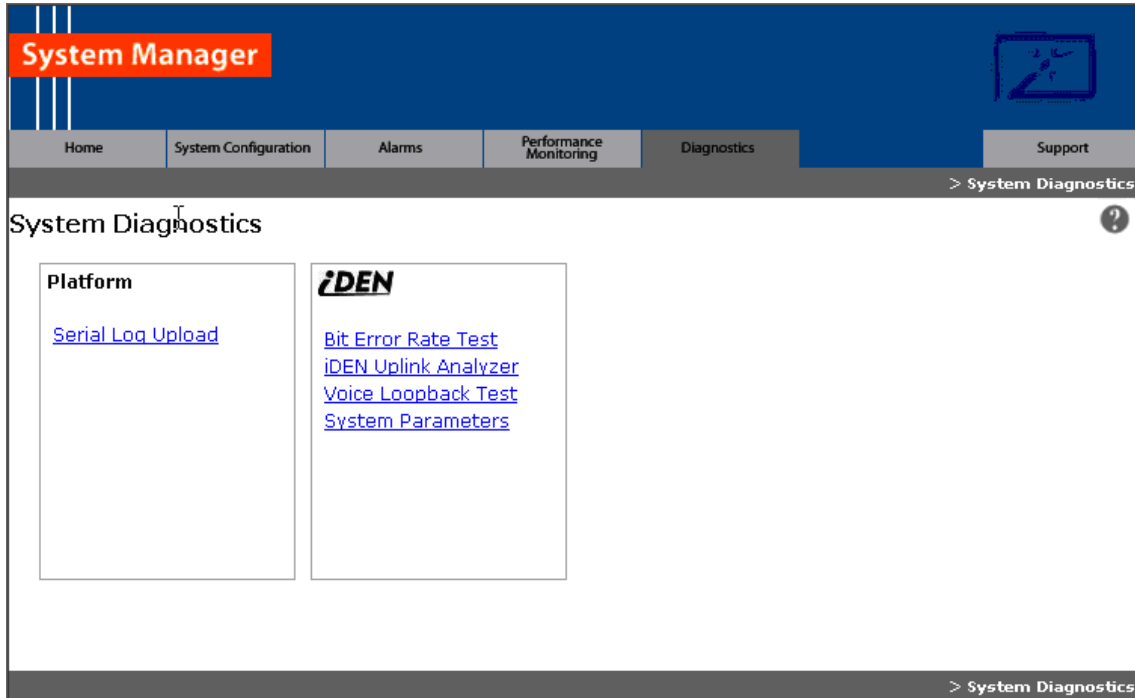

- 2 Select the **Upload Serial Log w/ IP Address** button, and in the pop-up window, enter the IP address of the component, and the select **OK**. Refer to Appendix B “IP Address Requirements”.

Alternately, the component can be selected from the dropdown menus, though RadioFrame Networks recommends using the IP address method.

Figure 57 Serial Log Upload Page with IP Address Prompt

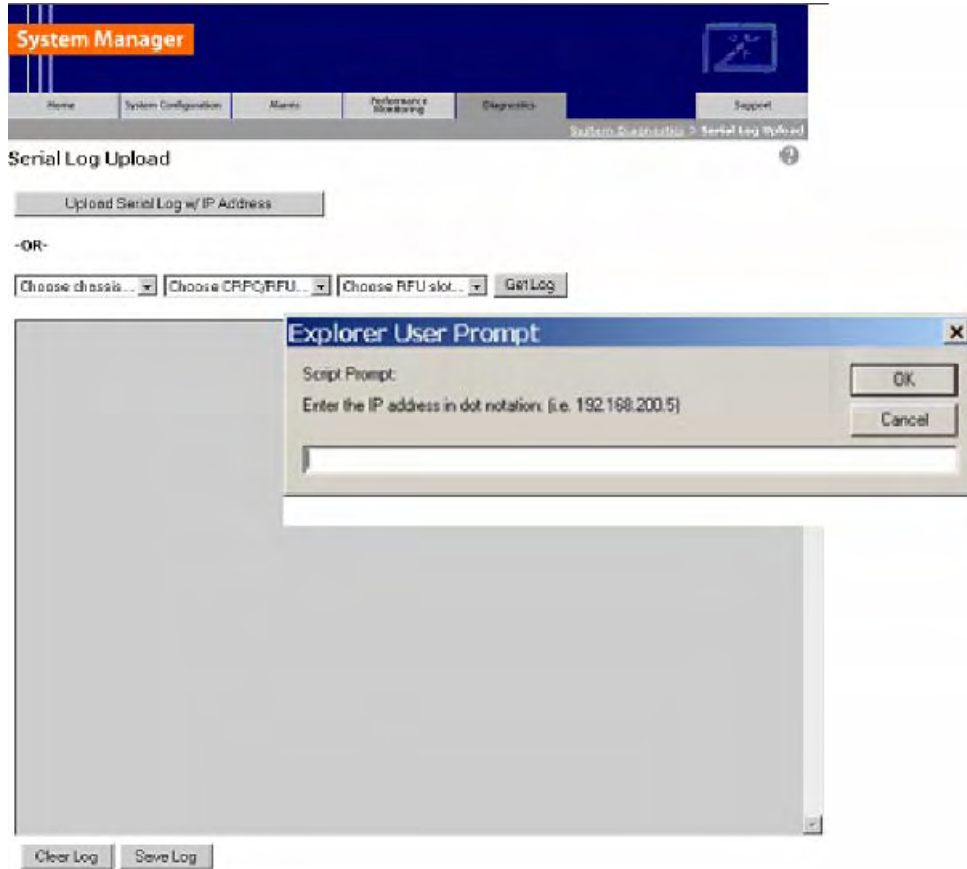

- 3 Copy the contents of the serial log window into a text file and save the text file.
- 4 Email the text file to the Technical Assistance Center at:
support@radioframenetworks.com

7.8 Power Down Procedure

When powering down the entire MC-Series system, follow these instructions.

Using the breakers on the PDU, power off equipment in the MC-Series system rack in the following order:

- BIC
- AIC
- RBS 1 (and RBS 2 if present)
- RF Shelf 1, RF Shelf 2 and RF Shelf 3
- CSU
- Secondary iSC-3; then ensure that the power switch on the front of the unit is in the OFF position
- EAS; then ensure that the power switch on the front of the unit is in the OFF position

- Primary iSC-3; then ensure that the power switch on the front of the unit is in the OFF position

7.9 Field Replaceable Unit (FRU) Procedures

The MC-Series system has been designed so that Field Repairable Units (FRUs) can be replaced to restore normal system operation as quickly as possible.

Refer to section 1.3 “Repair and Technical Support”, Table 1, which lists RadioFrame Networks FRUs. Do not attempt to repair RadioFrame Networks equipment and components in the field. Be sure to read section 1.3.2 “Field Replaceable Unit (FRU) Policy”.

For support of RadioFrame Networks equipment, contact the RadioFrame Networks Technical Assistance Center (TAC) at:

(US) 1-800-328-0847

For equipment not supplied by RadioFrame Networks, follow standard Sprint Nextel policies and procedures for FRU replacement.

7.9.1 RF Shelf

Figure 58 RF Shelf Front View

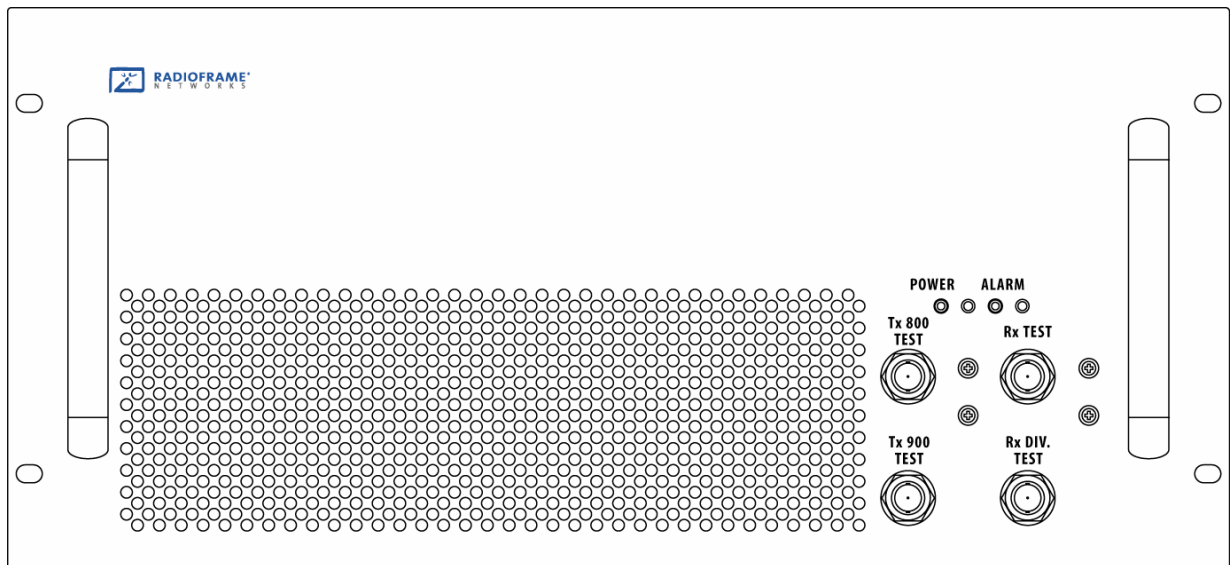
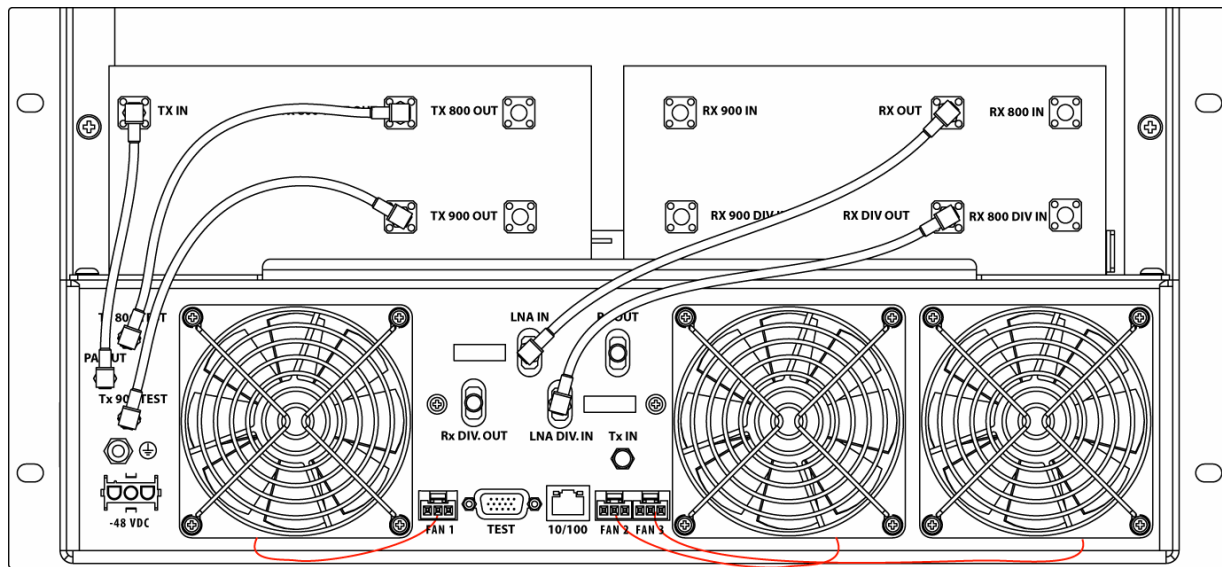

Figure 59 RF Shelf Rear View



7.9.1.1 RF Shelf Replacement Procedure

- 1 Power down RadioFrame Networks equipment in the following order using circuit breakers on the PDU:
 - BIC
 - AIC
 - RBS 1 (power down RBS 2 if present)
 - RF shelf 1, 2 and 3
- 2 Disconnect cabling from the back of the chassis to be replaced.

Refer to Appendix C “Medium Power iDEN Microcell Rack Stack-Up, 3-Sector (Default) Configuration” on page 122. Index letters are keyed to the figures in this appendix.

Disconnect the cabling from the rear of **RF Shelf**. (Table 32 is indexed to the cabling figures in Appendix C.) Repeat for each shelf to be swapped out.

Table 32 Cables to Disconnect from Rear of RF Shelf x (See NOTE)

Index	Disconnect From	To	Type
H	RF Shelf x: power	PDU: RF x	power
A	RF Shelf x: ground	GND BAR	ground
U-A	RF Shelf x: Tx IN A	RBS 1: Tx A	RF cable
S-A	RF Shelf x: Rx OUT A	RBS 1: Rx A	RF cable
L	RF Shelf x: TX 800 OUT	TOR: Tx 800 x	RF cable
AA	RF Shelf x: TX 900 OUT	TOR: Tx 900 x	RF cable
I	RF Shelf x: RX 800 IN	TOR: RF 800 x	RF cable
K	RF Shelf x: RX 900 IN	TOR: RF 900 x	RF cable
T	RF Shelf x: ALARM	RBS: ALARM INPUT A	serial

NOTE: Replace “x” in the table with the RF Shelf number.

- 3 Remove the 4 front mounting screws and remove the RF shelf from the rack, and then package it for shipment.

Figure 60 RF Shelf Mounting Screw Locations

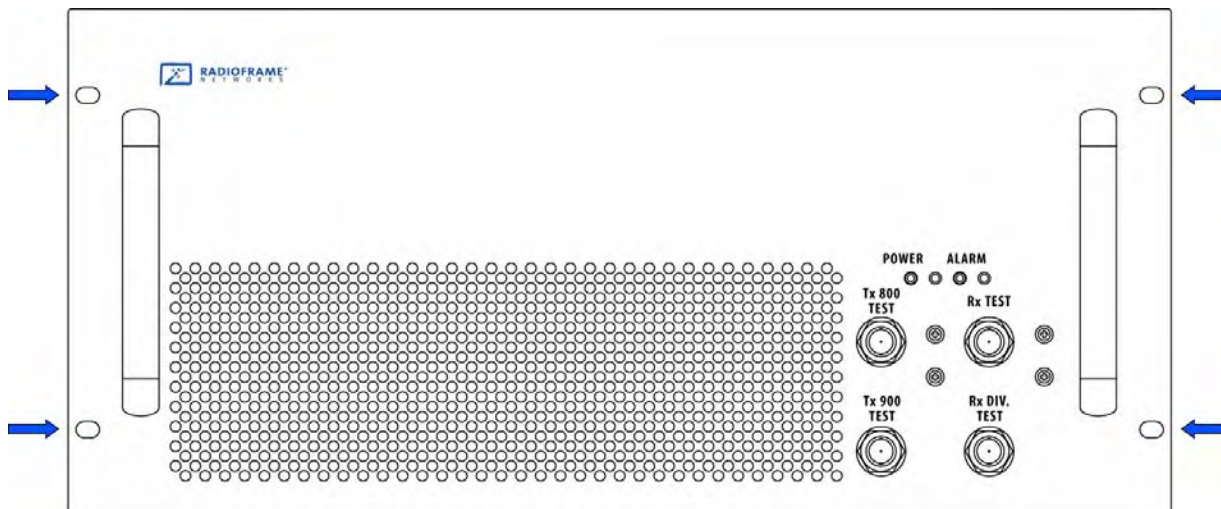

- 4 Mount the replacement RF shelf.

While supporting the RF shelf, slide it into the cabinet mounting position. Secure the RF shelf to the cabinet mounting rails using the four mounting screws provided with the unit. Tighten the screws to 4.5 Nm (40 in-lb).

- 5 Reconnect the cabling to the replacement chassis as defined in Step 2.

Use the SMA torque wrench for all SMA connectors.

- 6 Using the breakers on the PDU, turn up the BIC, AIC and RBS 1 (and RBS 2 if present), and then verify that the components are operational before proceeding.

- 7 Wait approximately 3 minutes for the following indicators:

- RBS: The STATUS LED for each group will turn green in this order: A, B and then C.
- RBS: The RADIOBLADE TRANSCEIVER STATUS LEDs will turn red and then green for each present RadioBlade transceiver. If no RadioBlade transceiver is present, the LED will not light. To verify the contents of the RBS, pull out the shelf (powering off is not required) and inspect the RadioBlade transceivers and their respective status LEDs. Reinsert the RBS. To do this, press up on one side rail locking arm and press down on the other side rail locking arm, and then push the unit into the rack. For an illustration of the locking arms, refer to Figure 71 on page 106.
- BIC CRIC and AIC CRIC: The POWER and STATUS LEDs will turn red and then green. All other BIC and AIC card LEDs will turn green.

- 8 Using the breaker on the PDU, turn up RF Shelf 1, RF Shelf 2 and RF Shelf 3 and verify that each RF shelf is operational before proceeding. The POWER and ALARM LEDs on the front of the RF Shelf will turn green.

- 9 Refer to sections 5.4 and 5.5 for configuration and verification.

7.9.1.2 Replacing a Fan in the RBS or an RF Shelf

- 1 Verify which fan has failed (look at each fan and determine which fan(s) are not turning).
- 2 Disconnect power from the fan.

3 Remove the four fan mounting screws.

Figure 61 Fan Mounting Screw Locations

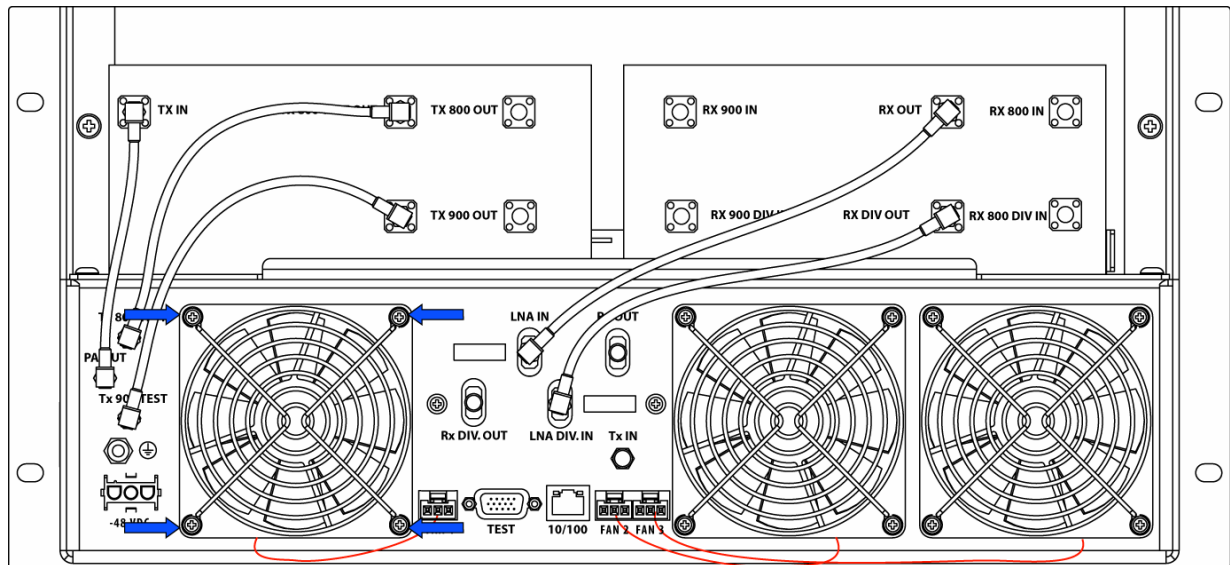

4 Replace the fan.

5 Install the four fan mounting screws.

Note: Install the finger guard so that the space is aligned vertically.

6 Connect the fan power cable.

7 Verify that the fan is working.

7.9.2 Replacing a Chassis: BIC, AIC or RBS

7.9.2.1 BIC

1 Power down RadioFrame Networks equipment in the following order using circuit breakers on the PDU:

- BIC
- AIC
- RBS 1 (and power down RBS 2 if present)
- RF Shelves 1, 2 and 3

2 Disconnect cabling from the back of the chassis to be replaced.

Refer to Appendix C "Medium Power iDEN Microcell Rack Stack-Up, 3-Sector (Default) Configuration" on page 122.

For the **BIC**, disconnect the cabling (from the rear of the BIC only) listed in Table 33. (Table 33 is indexed to the cabling figures in Appendix C.)

Table 33 Cables to be Disconnected from the BIC (shown grayed out)

Index	Disconnect From	To	Type
D	BIC: power	PDU: BIC	power
A	BIC: ground	GND BAR	ground
I-1	BIC: ERTM PORT 1	BIC: CRTC2 10baseT - ISC	UTP
I-2	BIC: ERTM PORT 2	AIC: ERTM PORT 4	UTP
I-3	BIC: ERTM PORT 3	BIC: CRTC1 10baseT - ISC	UTP
B	BIC: CRTC2 10base2 - ISC	ISC 1: 10B2-1	COAX (See Note)
C	BIC: CRTC2 10baseT - ISC	BIC: ERTM PORT 1	UTP (See Note)
H	BIC: ERTM 5MHz/1PPS IN	ISC 1: SITE REF OUT 1	COAX
J	BIC: CRTC1 10base2 - ISC	ISC 1: 10B2-2	COAX
K	BIC: CRTC1 10baseT - ISC	BIC: ERTM PORT 3	UTP

Note: CRTC 2 is optional. It may or may not be present in BIC rear slot 3.

- 3 Remove the chassis from the rack, and package it for shipment.
- 4 Remove the 4 front mounting screws from the front of the unit (see Figure 62).

Figure 62 Front View of BIC Showing Screw Locations

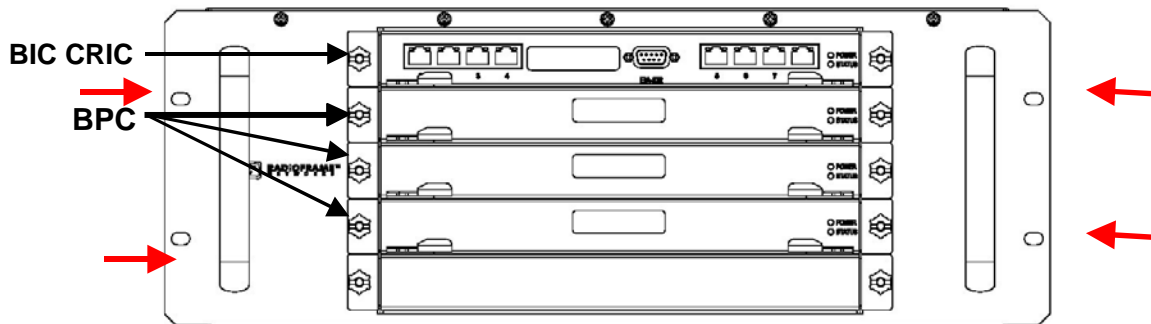

- 5 Mount the replacement chassis.

While supporting the chassis, slide the chassis into the cabinet mounting position. Secure the chassis to the cabinet mounting rails using the four mounting screws provided with the unit. Tighten the screws to 4.5 Nm (40 in-lb).

- 6 Reconnect the cabling to the replacement chassis as defined in Step 2.

Use the SMA torque wrench for all SMA connectors.

- 7 Using the breakers on the PDU, turn up the BIC, AIC and RBS 1 (and RBS 2 if present), and then verify that the components are operational before proceeding.

Wait approximately 3 minutes for the following indicators:

- RBS: The STATUS LED for each group will turn green in this order: A, B and then C.
- RBS: The RADIOBLADE TRANSCIVER STATUS LEDs will turn red and then green for each present RadioBlade transceiver. If no RadioBlade transceiver is present, the LED will not light. To verify the contents of the RBS, pull out the shelf (powering off is not required) and inspect the RadioBlade transceivers and their respective status

LEDs. Reinsert the RBS. To do this, press up on one side rail locking arm and press down on the other side rail locking arm, and then push the unit into the rack. For an illustration of the locking arms, refer to Figure 71 on page 106.

- BIC CRIC and AIC CRIC: The POWER and STATUS LEDs will turn red and then green. All other BIC and AIC card LEDs will turn green.
- 8 Using the breaker on the PDU, turn up each RF Shelf and then verify that each RF Shelf is operational before proceeding. The POWER and ALARM LEDs on the front of the RF Shelf will turn green.
 - 9 Complete the procedures in sections 5.4 and 5.5.

7.9.2.2 AIC

- 1 Power down RadioFrame Networks equipment in the following order using circuit breakers on the PDU:
 - BIC
 - AIC
 - RBS 1 (and power down RBS 2 if present)
 - RF Shelves 1, 2 and 3

- 2 Disconnect cabling from the back of the chassis to be replaced.

Refer to Appendix C "Medium Power iDEN Microcell Rack Stack-Up, 3-Sector (Default) Configuration" on page 122.

For the **AIC**, disconnect the cabling (from the rear of the AIC only) listed in Table 34. (Table 34 is indexed to the cabling figures in Appendix C.)

Table 34 Cables to be Disconnected from the AIC (shown grayed out)

Index	Disconnect From	To	Type
B	AIC: power	PDU: AIC	power
A	AIC: ground	GND BAR	ground
G1	AIC: ERTM PORT 1	RBS 1: 10/100 RFN A	UTP
G2	AIC: ERTM PORT 2	RBS 1: 10/100 RFN B	UTP
G3	AIC: ERTM PORT 3	RBS 1: 10/100 RFN C	UTP
G4	AIC: ERTM PORT 4	BIC: ERTM PORT 2	UTP

- 3 Remove the chassis from the rack, and package it for shipment.
- 4 Remove the 4 front mounting screws (see Figure 63).

Figure 63 Front View of AIC Showing Screw Locations

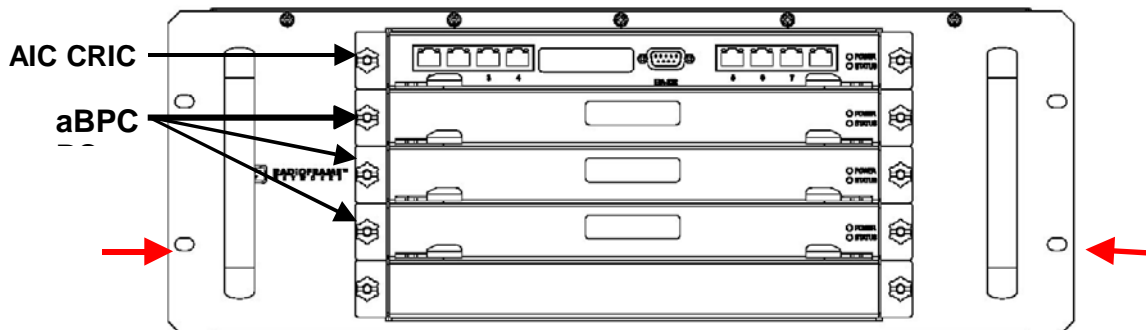

5 Mount the replacement chassis.

While supporting the chassis, slide the chassis into the cabinet mounting position. Secure the chassis to the cabinet mounting rails using the four mounting screws provided with the unit. Tighten the screws to 4.5 Nm (40 in-lb).

6 Reconnect the cabling to the replacement chassis as defined in Step 2.

Use the SMA torque wrench for all SMA connectors.

7 Using the breakers on the PDU, turn up the BIC, AIC and RBS 1 (and RBS 2 if present), and then verify that the components are operational before proceeding.

Wait approximately 3 minutes for the following indicators:

- RBS: The STATUS LED for each group will turn green in this order: A, B and then C.
- RBS: The RADIOBLADE TRANSCEIVER STATUS LEDs will turn red and then green for each present RadioBlade transceiver. If no RadioBlade transceiver is present, the LED will not light. To verify the contents of the RBS, pull out the shelf (powering off is not required) and inspect the RadioBlade transceivers and their respective status LEDs. Reinsert the RBS. To do this, press up on one side rail locking arm and press down on the other side rail locking arm, and then push the unit into the rack. For an illustration of the locking arms, refer to Figure 71 on page 106.
- BIC CRIC and AIC CRIC: The POWER and STATUS LEDs will turn red and then green. All other BIC and AIC card LEDs will turn green.

8 Using the breaker on the PDU, turn up each RF Shelf and then verify that each RF Shelf is operational before proceeding. The POWER and ALARM LEDs on the front of the RF Shelf will turn green.

9 Complete the procedures in sections 5.4 and 5.5.

7.9.2.3 RBS

1 Power down RadioFrame Networks equipment in the following order using circuit breakers on the PDU:

- BIC
- AIC
- RBS 1 (and power down RBS 2 if present)
- RF Shelves 1, 2 and 3

2 Disconnect cabling from the back of the RBS to be replaced.

Refer to Appendix C “Medium Power iDEN Microcell Rack Stack-Up, 3-Sector (Default Configuration)” on page 122. Disconnect the cabling (from the rear of RBS only) listed in Table 35. (Table 35 is indexed to the cabling figures in Appendix C.)

Table 35 Cables to be Disconnected from the Front of RBS 1 (shown grayed out)

Index	Disconnect From	To	Type
E	RBS: power	PDU: RBS 1	power
A	RBS: ground	GND BAR	ground
N	RBS: Tx A	RF Shelf 1: Tx IN A	RF cable
M	RBS: Rx A	RF Shelf 1: Rx OUT A	RF cable
K	RBS: ALARM INPUT A	RF Shelf 1: ALARM	serial (See Note)
J	RBS: 10/100 RFN A	AIC: ERTM PORT 1	UTP
P	RBS: Tx B	RF Shelf 2: Tx IN B	RF cable
U	RBS: Rx B	RF Shelf 2: Rx OUT B	RF cable
G	RBS: ALARM INPUT B	RF Shelf 2: ALARM	serial (See Note)
F	RBS: 10/100 RFN B	AIC: ERTM PORT 2	UTP
R	RBS: Tx C	RF Shelf 3: Tx IN C	RF cable
T	RBS: Rx C	RF Shelf 3: Rx OUT C	RF cable
C	RBS: ALARM INPUT C	RF Shelf 3: ALARM	serial (See Note)
B	RBS: 10/100 RFN C	AIC: ERTM PORT 3	UTP

Note: The serial alarm cable (RF Shelf x ALARM to RBS ALARM INPUT x) is not used with the Medium Power system. These cables may or may not be present.

- 3 Remove the 4 front mounting screws (see Figure 64), remove the chassis from the rack, and then package it for shipment.

Figure 64 Front View of RBS Showing Mounting Screws

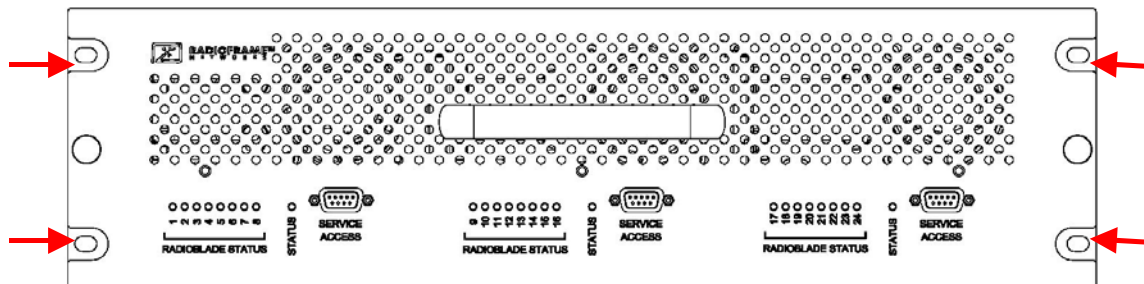

- 4 Mount the replacement chassis.
While supporting the chassis, slide the chassis into the cabinet mounting position. Secure the chassis to the cabinet mounting rails using the four mounting screws provided with the unit. Tighten the screws to 4.5 Nm (40 in-lb).
- 5 Reconnect the cabling to the replacement chassis as defined in Step 2.
Use the SMA torque wrench for all SMA connectors.

- 6 Using the breakers on the PDU, turn up the BIC, AIC and RBS 1 (and RBS 2 if present), and then verify that the components are operational before proceeding.

Wait approximately 3 minutes for the following indicators:

- RBS: The STATUS LED for each group will turn green in this order: A, B and then C.
 - RBS: The RADIOBLADE TRANSCEIVER STATUS LEDs will turn red and then green for each present RadioBlade transceiver. If no RadioBlade transceiver is present, the LED will not light. To verify the contents of the RBS, pull out the shelf (powering off is not required) and inspect the RadioBlade transceivers and their respective status LEDs. Reinsert the RBS. To do this, press up on one side rail locking arm and press down on the other side rail locking arm, and then push the unit into the rack. For an illustration of the locking arms, refer to Figure 71 on page 106.
 - BIC CRIC and AIC CRIC: The POWER and STATUS LEDs will turn red and then green. All other BIC and AIC card LEDs will turn green.
- 7 Using the breaker on the PDU, turn up each RF Shelf and then verify that each RF Shelf is operational before proceeding.
The POWER and ALARM LEDs on the front of the RF Shelf will turn green.
 - 8 Complete the procedures in sections 5.4 and 5.5.

7.9.3 BIC/AIC– FRU Replacement Procedure

BEFORE REPLACING ANY CARD (board) in the BIC or AIC, power down RadioFrame Networks equipment in the following order using circuit breakers on the PDU:

- BIC
- AIC
- RBS 1 (power down RBS 2 if present)
- RF Shelves 1, 2 and 3

7.9.3.1 Replacing the CRIC (BIC or AIC)

- 1 Before replacing any card (board) in the BIC or AIC, power down RadioFrame Networks equipment in the following order using circuit breakers on the PDU:
 - BIC
 - AIC
 - RBS 1 (and power down RBS 2 if present)
 - RF Shelves 1, 2 and 3
- 2 Always use a static grounding wrist strap before handling any board—do not attach the wrist strap to any painted surface on the chassis unit.
- 3 Facing the BIC or AIC, remove the CRIC that is to be replaced, following these guidelines:
 - Loosen the blue knurled knobs on both sides of the board.
 - Pull firmly on the tabs located on the bottom of the CRIC.
 - Gently slide the CRIC straight out and away from the chassis unit so as not to damage any components contained on the board.
- 4 Remove the replacement CRIC from its antistatic packaging and insert it into the chassis unit as shown in Figure 65, and follow these guidelines:
 - Do not jam the board in any way while inserting it.

- Do not mount the board in any orientation other than that specified in the diagram.
- Insert the board straight into the chassis unit so as not to damage any components contained on the board.
- Press firmly to seat the board into the connectors within the chassis unit.
- Tighten the blue knurled knobs on each end of the board finger tight only—do not use a screwdriver to tighten the screws and do not over tighten.

Figure 65 Replacing the CRIC in the BIC or AIC

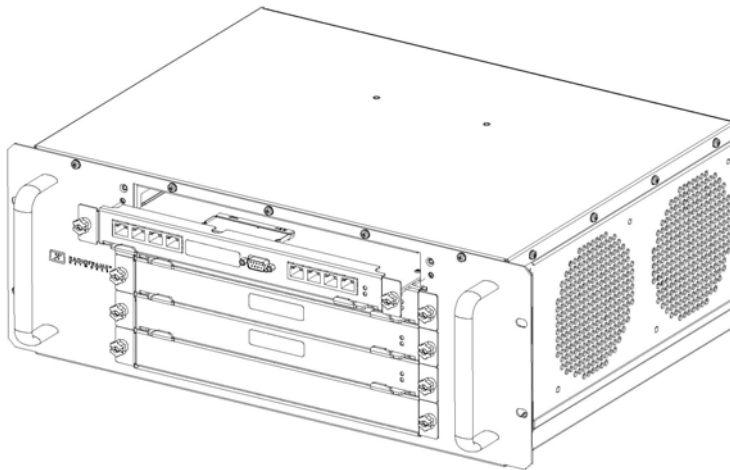

- 5 Place the old board in the antistatic packaging for shipment.
- 6 Using the breakers on the PDU, turn up the BIC, AIC and RBS 1 (and RBS 2 if present), and then verify that the components are operational before proceeding.
Wait approximately 3 minutes for the following indicators:
 - RBS: The STATUS LED for each group will turn green in this order: A, B and then C.
 - RBS: The RADIOBLADE TRANSCIEVER STATUS LEDs will turn red and then green for each present RadioBlade transceiver. If no RadioBlade transceiver is present, the LED will not light. To verify the contents of the RBS, pull out the shelf (powering off is not required) and inspect the RadioBlade transceivers and their respective status LEDs. Reinsert the RBS. To do this, press up on one side rail locking arm and press down on the other side rail locking arm, and then push the unit into the rack. For an illustration of the locking arms, refer to Figure 71 on page 106.
 - BIC CRIC and AIC CRIC: The POWER and STATUS LEDs will turn red and then green. All other BIC and AIC card LEDs will turn green.
- 7 Using the breaker on the PDU, turn up each RF Shelf and then verify that each RF Shelf is operational before proceeding.
The POWER and ALARM LEDs on the front of the RF Shelf will turn green.
- 8 FOR THE BIC CRIC ONLY: complete the procedures in sections 5.4 and 5.5.

7.9.3.2 BPC (BIC) or BPC+SPAM (AIC)

- 1 Before replacing any card (board) in the BIC or AIC, power down RadioFrame Networks equipment in the following order using circuit breakers on the PDU:
 - BIC
 - AIC

- RBS 1 (and power down RBS 2 if present)
 - RF Shelves 1, 2 and 3
- 2 Always use a static grounding wrist strap before handling any board—do not attach the wrist strap to any painted surface on the chassis unit.
 - 3 Facing the chassis unit, remove the BPC that is to be replaced, or the blank faceplate, following these guidelines:
 - Loosen the blue knurled knobs on both sides of the board.
 - Pull firmly on the tabs located on the bottom of the BPC you are replacing.
 - Gently slide the BPC straight out and away from the chassis unit so as not to damage any components contained on the board.
 - 4 Remove the BPC from its antistatic packaging and insert it into the chassis unit as shown in Figure 56, and follow these guidelines:
 - Do not jam the board in any way while inserting it.
 - Do not mount the board in any orientation other than that specified in the diagram.
 - Insert the board straight into the chassis unit so as not to damage any components contained on the board.
 - Press firmly to seat the board into the connectors within the chassis unit.
 - Tighten the blue knurled knobs on each end of the board finger tight only—do not use a screwdriver to tighten the screws and do not over tighten.

Figure 66 Replacing the BPC in the BIC or the BPC+SPAM in the AIC

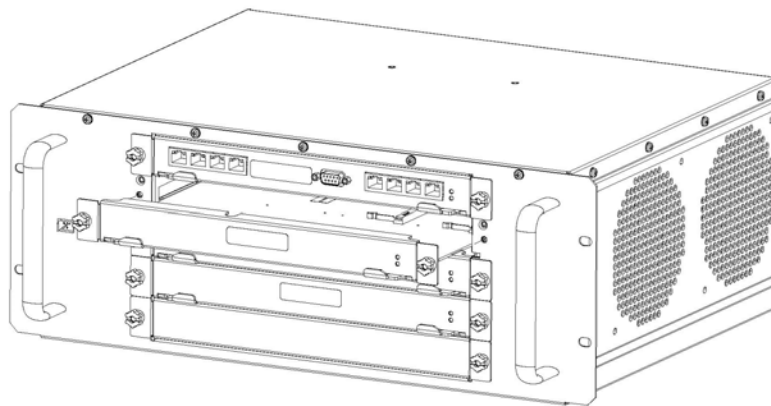

- 5 Place the old board in the antistatic packaging for shipment.
- 6 Using the breakers on the PDU, turn up the BIC, AIC and RBS 1 (and RBS 2 if present), and then verify that the components are operational before proceeding.
Wait approximately 3 minutes for the following indicators:
 - RBS: The STATUS LED for each group will turn green in this order: A, B and then C.
 - RBS: The RADIOBLADE TRANSCEIVER STATUS LEDs will turn red and then green for each present RadioBlade transceiver. If no RadioBlade transceiver is present, the LED will not light. To verify the contents of the RBS, pull out the shelf (powering off is not required) and inspect the RadioBlade transceivers and their respective status LEDs. Reinsert the RBS. To do this, press up on one side rail locking arm and press down on the other side rail locking arm, and then push the unit into the rack. For an illustration of the locking arms, refer to Figure 71 on page 106.

- BIC CRIC and AIC CRIC: The POWER and STATUS LEDs will turn red and then green. All other BIC and AIC card LEDs will turn green.
- 7 Using the breaker on the PDU, turn up each RF Shelf and then verify that each RF Shelf is operational before proceeding.

The POWER and ALARM LEDs on the front of the RF Shelf will turn green.

7.9.3.3 ERTM

- 1 Before replacing any card (board) in the BIC or AIC, power down RadioFrame Networks equipment in the following order using circuit breakers on the PDU:
 - BIC
 - AIC
 - RBS 1 (and power down RBS 2 if present)
 - RF Shelves 1, 2 and 3
- 2 Always use a static grounding wrist strap before handling any board—do not attach the wrist strap to any painted surface on the chassis unit.

Note: The ERTM you remove from the BIC or AIC may appear slightly different from the replacement ERTM. The current-revision ERTM—labeled “ERTM ASY 0562 XX”, where $XX \geq 06$ —is used in either the AIC or BIC and is configured by means of a switch (step 4). The down-rev AIC ERTM faceplate is labeled “PERTM ASY 0560 XX”, and the down-rev BIC ERTM is identified “ERTM ASY 0562 XX”, where $XX \leq 05$. These down-rev ERTMs do not have a switch on the circuit board and therefore cannot be swapped from one type of interface chassis to the other.
- 3 Facing the rear of the BIC or AIC, remove the ERTM that is to be replaced following these guidelines:
 - Loosen the blue knurled knobs on both sides of the board.
 - Pull firmly on the tabs located on the bottom of the ERTM you are replacing.
 - Gently slide the ERTM straight out and away from the chassis unit so as not to damage any components contained on the board.
- 4 Remove the ERTM from its antistatic packaging and insert it into the chassis unit as shown in Figure 67, and follow these guidelines:
 - Check that the ERTM switch is in the correct position for the application. The switch is located on the components side of the ERTM circuit board, near the connector labeled “POWER”. Appropriate settings are:
 - A—for ERTM inserted in AIC
 - B—for ERTM inserted in BIC.
 - Do not jam the board in any way while inserting it.
 - Do not mount the board in any orientation other than that specified in the diagram.
 - Insert the board straight into the chassis unit so as not to damage any components contained on the board.
 - Press firmly to seat the board into the connectors within the chassis unit.
 - Tighten the blue knurled knobs on each end of the board finger tight only—do not use a screwdriver to tighten the screws and do not over tighten.

Figure 67 Rear of BIC (ERTM and CRTC) and AIC (ERTM Only)

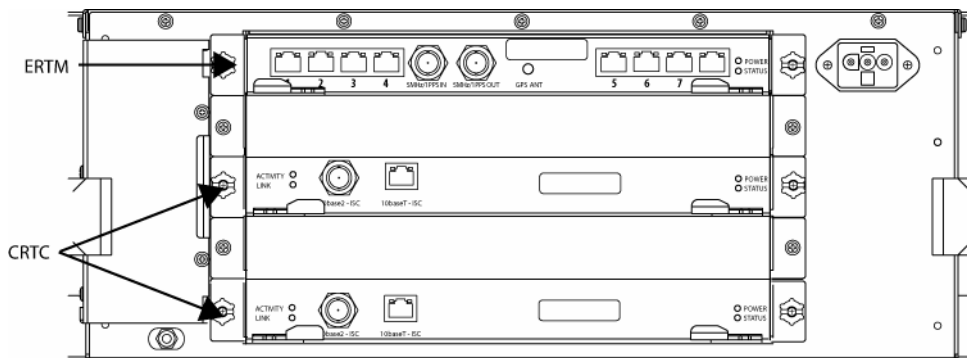

5 Place the old board in the antistatic packaging for shipment.

6 Using the breakers on the PDU, turn up the BIC, AIC and RBS 1 (and RBS 2 if present), and then verify that the components are operational before proceeding.

Wait approximately 3 minutes for the following indicators:

- RBS: The STATUS LED for each group will turn green in this order: A, B and then C.
- RBS: The RADIOBLADE TRANSCIVER STATUS LEDs will turn red and then green for each present RadioBlade transceiver. If no RadioBlade transceiver is present, the LED will not light. To verify the contents of the RBS, pull out the shelf (powering off is not required) and inspect the RadioBlade transceivers and their respective status LEDs. Reinsert the RBS. To do this, press up on one side rail locking arm and press down on the other side rail locking arm, and then push the unit into the rack. For an illustration of the locking arms, refer to Figure 71 on page 106.
- BIC CRIC and AIC CRIC: The POWER and STATUS LEDs will turn red and then green. All other BIC and AIC card LEDs will turn green.

7 Using the breaker on the PDU, turn up each RF Shelf and then verify that each RF Shelf is operational before proceeding.

The POWER and ALARM LEDs on the front of the RF Shelf will turn green.

7.9.3.4 CRTC

1 Before replacing any card (board) in the BIC, power down RadioFrame Networks equipment in the following order using circuit breakers on the PDU:

- BIC
- AIC
- RBS 1 (and power down RBS 2 if present)
- RF Shelves 1, 2 and 3

2 Always use a static grounding wrist strap before handling any board—do not attach the wrist strap to any painted surface on the chassis unit.

3 Facing the rear of the BIC, remove the CRTC following these guidelines:

- Loosen the blue knurled knobs on both sides of the board.
- Pull firmly on the tabs located on the bottom of the CRTC.
- Gently slide the CRTC straight out and away from the chassis unit so as not to damage any components contained on the board.

4 Remove the CRTC from its antistatic packaging and insert it into the chassis unit as shown in Figure 67, and follow these guidelines:

- Do not jam the board in any way while inserting it.

- Do not mount the board in any orientation other than that specified in the diagram.
 - Insert the board straight into the chassis unit so as not to damage any components contained on the board.
 - Press firmly to seat the board into the connectors within the chassis unit.
 - Tighten the blue knurled knobs on each end of the board finger tight only—do not use a screwdriver to tighten the screws and do not over tighten.
- 5 Place the old board in the antistatic packaging for shipment.
 - 6 Using the breakers on the PDU, turn up the BIC, AIC and RBS 1 (and RBS 2 if present), and then verify that the components are operational before proceeding.

Wait approximately 3 minutes for the following indicators:

- RBS: The STATUS LED for each group will turn green in this order: A, B and then C.
 - RBS: The RADIOBLADE TRANSCEIVER STATUS LEDs will turn red and then green for each present RadioBlade transceiver. If no RadioBlade transceiver is present, the LED will not light. To verify the contents of the RBS, pull out the shelf (powering off is not required) and inspect the RadioBlade transceivers and their respective status LEDs. Reinsert the RBS. To do this, press up on one side rail locking arm and press down on the other side rail locking arm, and then push the unit into the rack. For an illustration of the locking arms, refer to Figure 71 on page 106.
 - BIC CRIC and AIC CRIC: The POWER and STATUS LEDs will turn red and then green. All other BIC and AIC card LEDs will turn green.
- 7 Using the breaker on the PDU, turn up each RF Shelf and then verify that each RF Shelf is operational before proceeding.

The POWER and ALARM LEDs on the front of the RF Shelf will turn green.

7.9.4 RadioBlade Transceiver Replacement

The MC-Series system supports hot swapping of RadioBlade transceivers. This means replacement of a RadioBlade transceiver can be done while the system is live and does not require a system reset. When RadioBlade transceivers are hot swapped, no alarm is generated. Rather, a RadioBlade transceiver lock / unlock event is placed in the System-Manager Event Log.

Each RadioBlade transceiver is shipped wrapped in antistatic packaging, along with a lockdown strap and screw for securing the RadioBlade transceiver in the RadioBlade Shelf (RBS).

Note: Use an SMA torque wrench (such as the Huber & Suhner 742-0-0-21 SMA torque wrench) for removing and installing RadioBlade transceivers.

Figure 68 Front View of the RadioBlade Shelf (RBS)

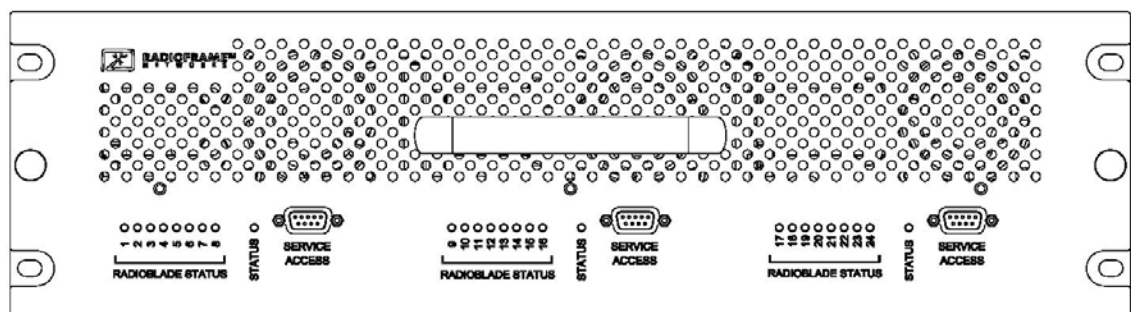

- 1 Take the RadioBlade transceiver out of service by locking it (refer to the procedure in section 6.2.2.3: “Locking and Unlocking a RadioBlade Transceiver”).

The RBS is divided into three groups (A, B and C) from left to right. Slots in each group are numbered as follows, from front to back:

- Group A: slots 1 through 8
- Group B: slots 9 through 16
- Group C: slots 17 through 24

- 2 Pull out the RBS using the handle on the front of the unit.
- 3 Remove the RadioBlade transceiver that is to be replaced (see Figure 69).

Using the SMA torque wrench, disconnect the Rx and Tx cables from the RadioBlade transceiver. Then loosen the screw of the lockdown strap covering the RadioBlade transceiver, and remove the strap and screw and place them aside. Then gently lift and remove the RadioBlade transceiver from the slot in the RBS backplane. Place the RadioBlade transceiver in anti-static packaging for shipment.

Figure 69 RadioBlade Transceiver in Place

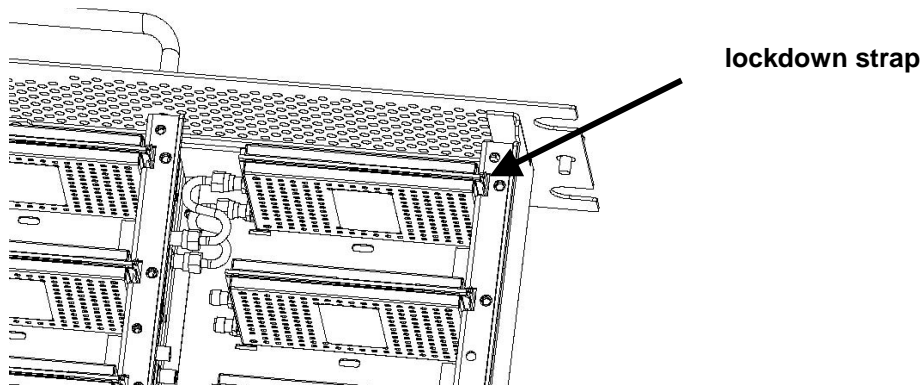

- 4 Un-package the replacement RadioBlade transceiver to be inserted into the RBS.
- 5 Insert the RadioBlade transceiver into the specified slot in the RBS until the connector seats firmly into the backplane of the RBS.
- 6 Place the lockdown strap over the RadioBlade transceiver by inserting the two feet on the strap into the slots on the RBS backplane, and then hand tighten the screw into place.

Figure 70 Seating the RadioBlade Transceiver

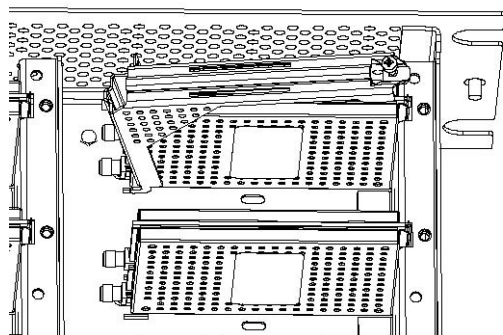

- 7 Connect the Rx and Tx cables to the correct ports on the RadioBlade transceiver, and use the SMA torque wrench to tighten.
- 8 Re-insert the RBS into its chassis. To do this, press up on one side rail locking arm and press down on the other side-rail locking arm, and then push the unit into the rack (see Figure 71).

Figure 71 RF Shelf Showing Side-Rail Locking Arm Locations



- 9 In System Manager, refresh the RBS Status page until the RadioBlade transceiver icon status bar changes from red (not present) to yellow (present and locked). This will take approximately three minutes.
- 10 Unlock the RadioBlade transceiver.
On the RadioBlade Transceiver Control page, the **State** of the RadioBlade transceiver will change from 2 (locked) to 11 (unlocked).

7.9.5 Power Distribution Unit

The Power Distribution Unit (PDU) receives DC input and supplies power via dedicated circuit breakers to each component in the MC-Series system. Each of the thirteen breakers has a three-position switch: ON, OFF or TRIPPED. The single alarm output connected to each breaker is normally closed and goes open when a breaker is tripped.



Verify that all breakers in the PDU are in the OFF position prior to proceeding. Leave them in the OFF position until instructed otherwise.

- 1 Verify that all breakers are in the OFF position on the front of the PDU.
- 2 Follow the power supply and battery manufacturer's installation and maintenance documentation to remove power from the PDU.
- 3 Disconnect the powerplant from the PDU using the two lugs.

- 4 Remove all power connections from the back of the PDU.
- 5 Remove the 4 front mounting screws from the front of the PDU, and remove the PDU from the rack, and then package it for shipment.

Figure 72 PDU, Medium Power Rear View

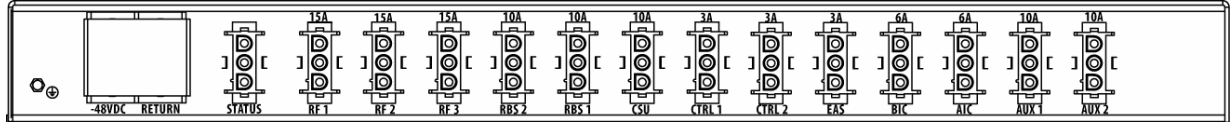
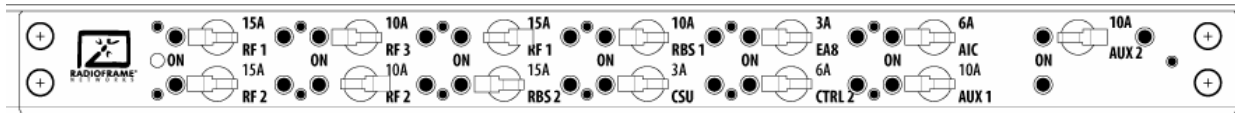

Figure 73 PDU, Medium Power Front View



- 6 Mount the replacement PDU.

While supporting the PDU, slide it into the cabinet mounting position. Secure the PDU to the cabinet mounting rails using the four mounting screws provided with the unit. Tighten the screws to 4.5 Nm (40 in-lb).
- 7 Reconnect all power connections to the back of the PDU.
- 8 Follow Power supply and battery manufacturer's installation and maintenance documentation to install power to PDU.
- 9 Using the breakers on the PDU, turn up the BIC, AIC and RBS 1 (and RBS 2 if present), and then verify that the components are operational before proceeding.

Wait approximately 3 minutes for the following indicators:

 - RBS: The STATUS LED for each group will turn green in this order: A, B and then C.
 - RBS: The RADIOBLADE TRANSCIEVER STATUS LEDs will turn red and then green for each present RadioBlade transceiver. If no RadioBlade transceiver is present, the LED will not light. To verify the contents of the RBS, pull out the shelf (powering off is not required) and inspect the RadioBlade transceivers and their respective status LEDs. Reinsert the RBS. To do this, press up on one side rail locking arm and press down on the other side rail locking arm, and then push the unit into the rack. For an illustration of the locking arms, refer to Figure 71 on page 106.
 - BIC CRIC and AIC CRIC: The POWER and STATUS LEDs will turn red and then green. All other BIC and AIC card LEDs will turn green.
- 10 Using the breaker on the PDU, turn up each RF Shelf and then verify that each RF Shelf is operational before proceeding. The POWER and ALARM LEDs on the front of the RF Shelf will turn green.
- 11 Complete the procedures in sections 5.4 and 5.5.

8 System Configuration Changes

8.1 Upgrading MC-Series System Software

The MC-Series Medium Power system is shipped with the latest software installed. With each new software release, RadioFrame Networks provides its customers with the new software and accompanying information in the *RadioFrame Networks Customer Release Notes*. The following procedures describe how to upgrade MC-Series system software. System Manager contains two separate partitions in which to install software: active and inactive. This provides the means to revert back to a previous version of system software if required.

8.1.1 Download MC-Series System Software to the Laptop Computer

Note: If the laptop already contains the **docs**, **platform** and **iden** directories for the system software in the root, you may wish to delete these directories and all of their contents before downloading and extracting the latest system software. This way you can ensure a complete clean install.

Download the latest system software, a self-extracting zip file, from:

<http://www.radioframenetworks.com/partners>

- 1 Navigate to the Sprint Nextel support pages. If you have not visited the RadioFrame Networks PartnerWeb site, you will be asked to register. Use your Sprint e-mail address and create a password.
- 2 Once your account is authenticated, install/extract the zip file directly into the C:/ drive on the laptop. The install creates three directories at the root level: **docs**, **platform** and **iden**.

8.1.2 Download FTP Server Software to the Laptop Computer

You will need an FTP server application running on the laptop computer. If one is already installed, you can skip to section 8.1.3 "Install the MC-Series System Software Update" on page 112. The following procedure installs a shareware program (Wftpd.exe) and configures it correctly. Use the method for your version of Windows.

8.1.2.1 Windows XP Method

Windows XP is capable of correctly configuring Wftpd.exe if you follow these steps.

- 1 Download Wftpd.exe, a self-extracting zip file, from:
<http://www.radioframenetworks.com/partners>
or from
<http://www.wftpd.com/>
- 2 Open the zip file with your archive/compress/extract utility (e.g., WinZip).
- 3 Extract to your Windows drive root directory (e.g., C:\).
- 4 From the Windows Start menu, select Run.
- 5 Click **Browse. . .** in the Run dialog box and browse to
C:\Program Files\WFTPD
(Windows XP should have placed the properly configured executable **Wftpd.exe** in

Program Files\WFTPD. If you do not see it there, you need to follow the Windows 2000 configuration method.)

- 6 In the **Browse** dialog box, select the file **Wftpd.exe** and click **Open**.

Figure 74 Executing Wftpd from the Windows XP Laptop Run Dialog Box

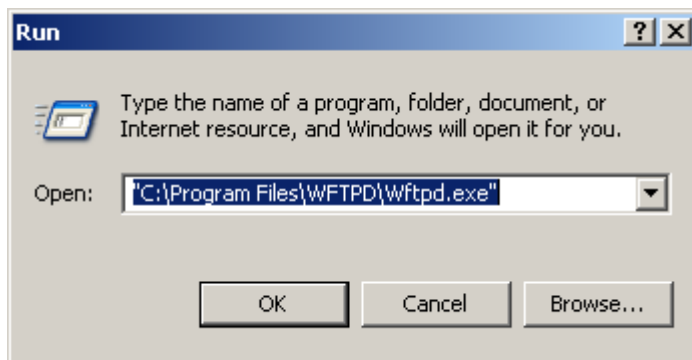

- 7 Click **OK** in the Run dialog box to start WFTPD.
- 8 Check configuration as follows: Navigate to the **Security** menu and select **Users/Rights . . .**. In the **User/Rights Security** dialog box, select **board** from the **User Name** drop down list.

Now proceed to the section “Install the MC-Series System Software Update on” page 112 to upgrade the system software.

8.1.2.2 Windows 2000 Method

- 1 Download Wftpd.exe, a self-extracting zip file, from:
<http://www.radioframenetworks.com/partners>
or from
<http://www.wftpd.com/>
- 2 Open the zip file with your archive/compress/extract utility (e.g., WinZip).
- 3 Extract to your Windows drive root directory (e.g., C:\).
- 4 From the Windows Start menu, select **Run**.
- 5 Open the FTP Server – enter **C:\Wftpd.exe** in the dialog box and click **OK**.

Figure 75 Executing Wftpd from the Windows 2000 Laptop Run Dialog Box

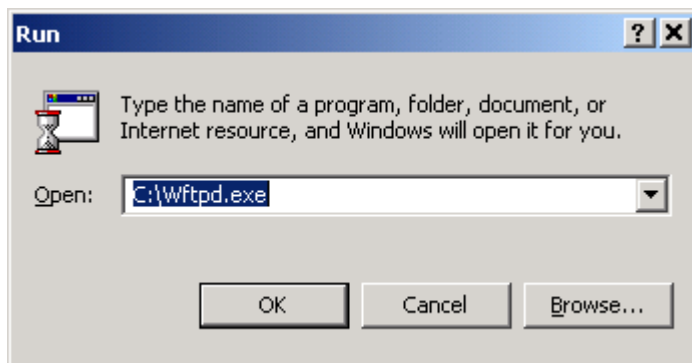

6 The configuration in Figure 76 is for Wftpd:

Figure 76 Wftpd Settings (Bottom of Screen Shot)

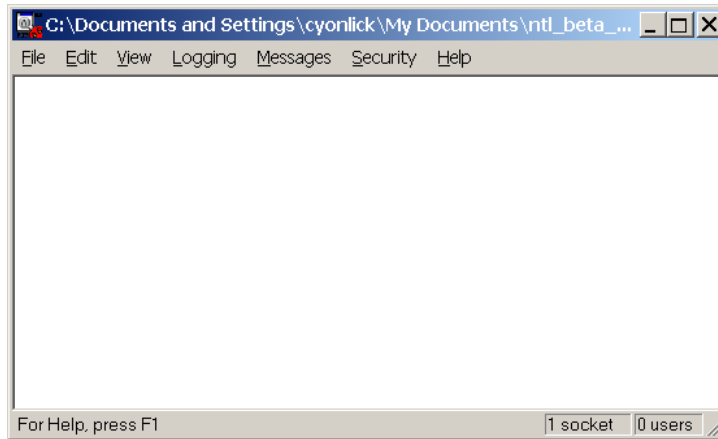

7 From the **Security** menu, select **General**, configure the **General Security** page as shown in Figure 77 and then select **OK**.

Figure 77 General Security Dialog Box Settings

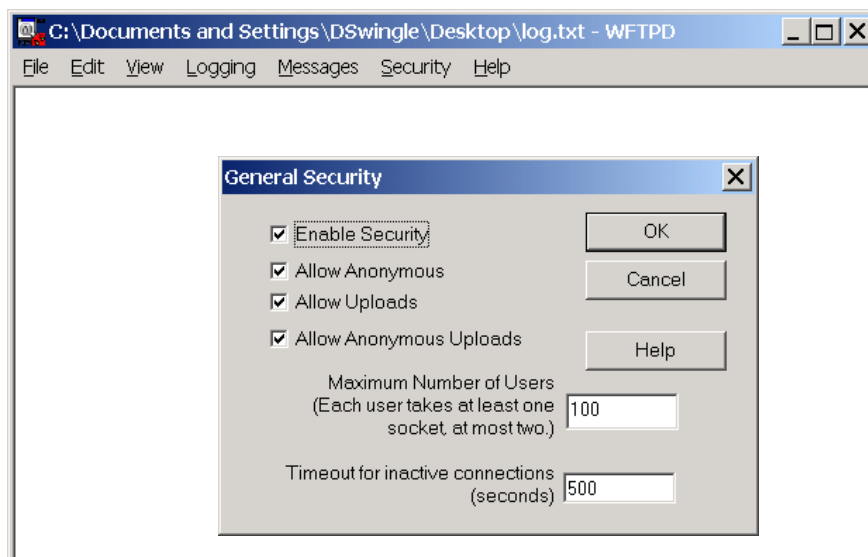

8 From the **Security** menu, select **User/rights**, and for **User Name** select **anonymous** from the drop down menu, and then select the **Rights<<** button and verify that the settings are the same as shown in Figure 78.

Figure 78 User / Rights Security Dialog Box Settings

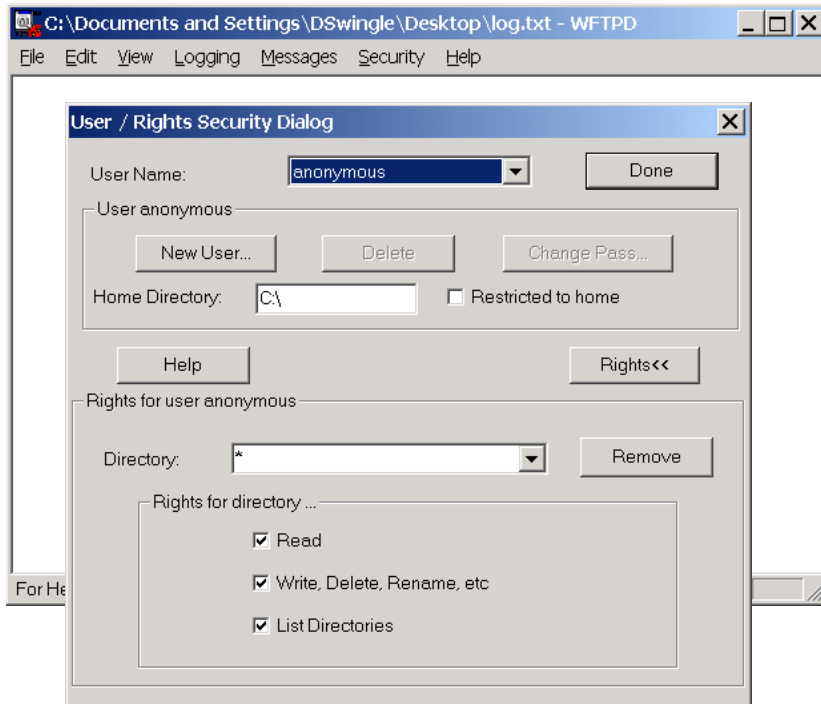

9 Select the **New User...** button, and then for **User Name** type **board** in the text box, and then select **OK**.

Figure 79 New-User Name

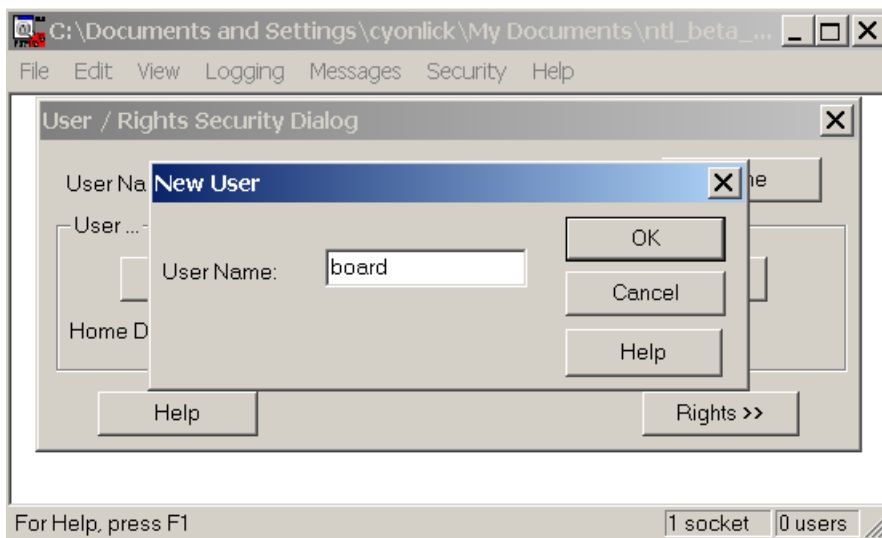

10 For **New Password** type **wind**, then retype **wind** in the **Verify Password** text box, and then select **OK**.

Figure 80 Password



- 11 The User/Rights Security dialog box reappears, and the **User Name** is now set to **board**. Select the **Rights** button and verify that the settings are the same as shown below, and then select **Done**.

Figure 81 User Name Set in User/Rights Security Dialog Box

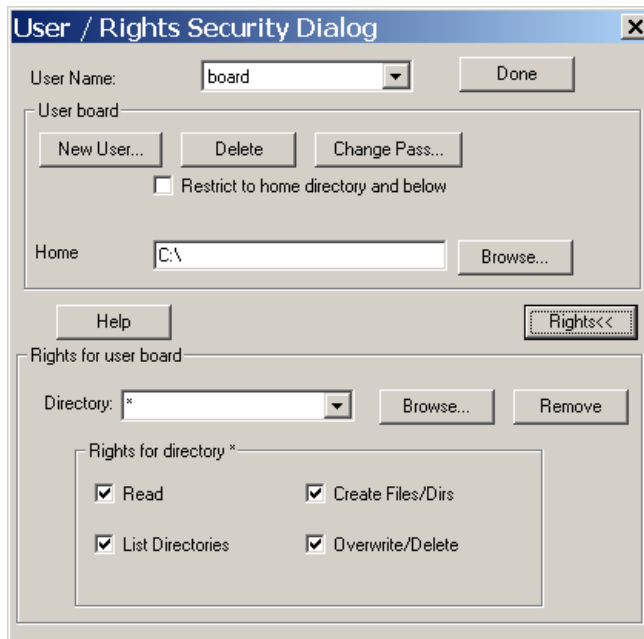

Now proceed to the next section to upgrade the system software.

8.1.3 Install the MC-Series System Software Update

The following procedure assumes that the MC-Series system is currently running at least the **RFN MCRB 14.0** release, and that the system is to be upgraded to the RFN MC 14.0 Medium Power load. If this is not the case, the system must first be upgraded to a version

of RFN software that supports software baselining. For SW download scenarios involving other software upgrades or downgrades, please contact RFN Technical Support for specific instructions **(1-800-328-0847)**.

The procedure also assumes that the service laptop to be used for upgrading the system software contains the system software load extracted to the root directory and that the correctly configured FTP server is running on the laptop. If this software is not yet in place, please start at section 8.1, "Upgrading MC-Series System Software".

- 1 Connect the laptop to the MC-Series system, start System Manager, and log in (for complete instructions, refer to section 5.4 "System Setup").
- 2 Navigate to the **Software Download & System Reset** page (Figure 82) by selecting the **System Configuration** tab and clicking on the **Software Download & System Reset** link.

Note: Before starting the download (in step 3), be sure to clear any FTP Server Address that shows up in the **Remote Software Download Settings** field. If you need to clear an address from this field, you must click the **Save Changes** button.

Figure 82 Download and Reset Links

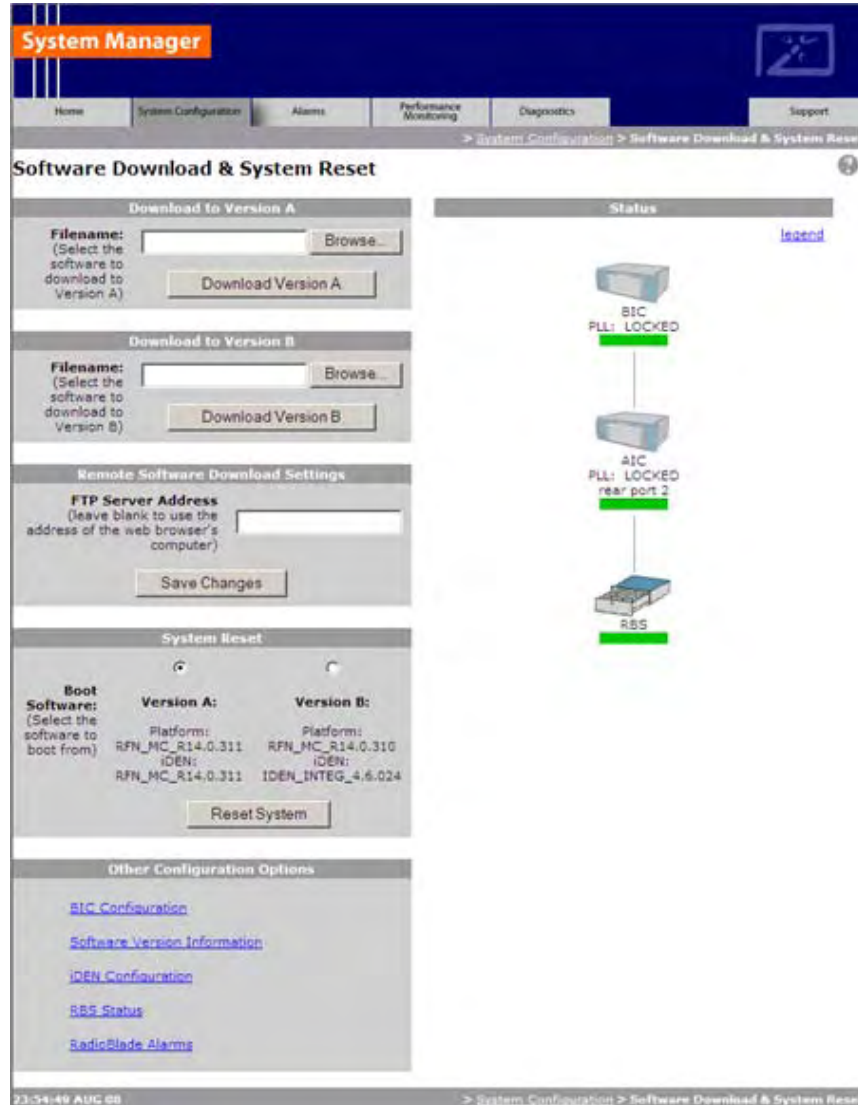

Note: iDEN Cabinet/Sector Information is not preserved in a downgrade from a 14.0 MCRB release to any non-MCRB release. Care should be taken to record this information and re-enter it as necessary after a downgrade.

Note: In the following procedures, ffs0 is partition A; ffs1 is partition B.

- Using the inactive partition—"Download Version A" or "Download Version B" in System Manager—navigate to the /platform/loads/MC-Series directory, and then run the download on the following two files (observe the Download Successful page; if a file fails, download it again):

- **rom_staging.txt**
- **plat_staging.txt**

The inactive partition is the one that is not selected under System Reset (A or B). Browse for the file in the text box of the inactive partition, A or B, and then select the **Download to Version...** button.

- 4 Using the inactive partition—“Download Version A” or “Download Version B” in System Manager—navigate to the /iden2/loads/BplusMC-Series directory, and then run the download on the following file (observe the Download Successful page; if it fails, repeat the download):

- **iden_staging.txt**

Reboot the system using System Manager to the new load and wait for the download to complete successfully, which may take several minutes.

This release must also be downloaded to the other partition at this time.

- 5 Using the inactive partition—“Download Version A” or “Download Version B” in System Manager—navigate to the /platform/loads/MC-Series directory and run the download on the following file (observe the Download Successful page; if it fails, repeat the download):

- **plat_staging.txt**

- 6 Using the inactive partition—“Download Version A” or “Download Version B” in System Manager—navigate to the /iden2/loads/BplusMC-Series directory, and run the download on the following file (observe the Download Successful page; if it fails, repeat the download):

- **iden_staging.txt**

Reboot the system using System Manager to the new load and wait for the download to complete successfully, which may take several minutes.

8.1.4 Verify the Software Download

- 1 Select the Software Version Information link on the System Configuration page.

Figure 83 Software Version Information Page

- 2 Review the SW Versions A and SW Versions B to make sure the latest software is loaded in the correct partition.
- 3 Verify that the SW Selected and SW Loaded for each component in the system is correct.

8.1.5 Reverting to the previous version of software

Revert to a previous version of MC-Series system software only if the upgrade fails.

- 1 Select the **Software Download & System Reset** link on the System Configuration page.
- 2 On the Software Download & System Reset page (Figure 82), under **System Reset**, select the inactive partition to revert to the previously loaded version of software.
- 3 Select the Reset System button.

This reboot will take several minutes to complete. Wait for the system to come back, and then refresh the page or reopen the web browser to force the page to update.

8.2 Performing a System Reset

- 1 If necessary, connect the laptop to the MC-Series system, start System Manager, and log in (for complete instructions, refer to section 5.4 “System Setup”).

- 2 Select the **Software Download & System Reset** on the System Configuration page.
- 3 On the Software Download & System Reset page (Figure 82), select the Reset System button.

8.3 Adding or Removing RadioBlade Transceivers

The MC-Series Medium Power system supports hot swapping of RadioBlade transceivers. This means that replacement of a RadioBlade transceiver can be done while the system is live and does not require a system reset. When RadioBlade transceivers are hot swapped no alarm is generated. Rather, a RadioBlade transceiver lock and unlock event is placed in the System Manager Event log.

Each RadioBlade transceiver is shipped wrapped in antistatic packaging, along with a lockdown strap and screw for securing the RadioBlade transceiver in the RadioBlade Shelf (RBS).

Follow the procedure in section 7.9.4 “RadioBlade Transceiver Replacement” to add or remove a RadioBlade transceiver.

8.4 Field Replaceable Units (FRUs), Parts and Extra Supplies

Sprint Nextel purchases spares for the MC-Series system and maintains inventories in Logistics Centers for ordering on an as-needed basis.

The MC-Series Medium Power system has been designed so that Field Replaceable Units (FRUs) can be replaced to restore normal system operation as quickly as possible. Refer to section 1.3.2 “Field Replaceable Unit (FRU) Policy”, section 7.9 “Field Replaceable Unit (FRU) Procedures” and the FRU table, Table 1. For equipment not supplied by RadioFrame Networks, such as the EAS or CSU, follow standard Sprint Nextel policies and procedures for FRU replacement.

This section contains recommended part numbers (P/N) and manufacturers of various hardware, tools and equipment used during the installation, operations and maintenance of the MC-Series system.

8.4.1 Matching Terminals for PDU and Ground

Select from the list of termination lugs in Table 36 (listed is the smallest packaging size available); use two when connecting the powerplant to the PDU and one when connecting the PDU ground to the top of the bus bar.

Table 36 Power and Ground Lugs

P/N	AWG	Config.	Quantity (per Package)
LCD2-14A-Q	2	Straight	25
LCD2-14AF-Q	6	Straight	25
LCD6-14A-L	2	Right Angle	50
LCD6-14AF-L	6	Right Angle	50

Note: Crimp Tool needed: CT-1700

8.4.2 GPS surge arrester

Figure 84 shows the surge arrester dimensions and Table 37 shows the performance specifications.

Figure 84 PolyPhaser RGT Broadband DC Pass Protector

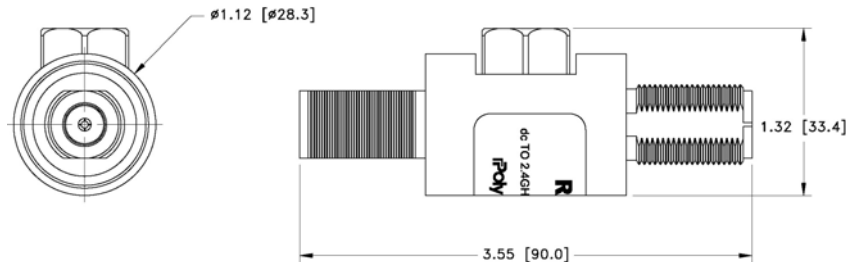

Table 37 Surge Arrester Specifications

Current	10 ADC
Insertion Loss	≤ 0.25 dB
Freq. Range	0-2400 MHz
Mounting	Bulkhead
Operating Voltage	+/-60 V
Protected Side Connector	N Female 50 Ω
Replaceable Gas Tube	Yes
Surge Side Connector	N Female 50 Ω
Throughput Energy	≤ 2283 μ J for 3 kA @ 8/20 μ s Waveform
Turn-On Voltage	+/-180 Volts
Unit Impedance	50 Ω
Voltage Standing Wave Ratio	1.28 : 1
Weatherized	Bellcore #TA-NWT-000487 Procedure 4.11, Wind Driven (120 mph) Rain Intrusion.

8.4.3 RF Feed-Throughs (N-type connectors)

Table 38 Specifications for N-Type Feed-Through Connectors

RFN P/N	Config. / Specs.	S.M Electronics P/N
514-0001-99	Terminator, N-M w/ chain 2 W 6 GHz, 18 dB max VSWR @ 6 GHz	STN0610C

Appendix A. Definitions and Abbreviations

Term	Definition
800E	Extended 800 MHz Band (800S+800U)
BER	Bit Error Rate
BR	Base Radio
CALEA	Communications Assistance for Law Enforcement Act
CAT5	Category 5 (Cable)
DAS	Distributed Antenna System
EBRC	Enhance Base Radio Controller
EBTS	Enhanced Base Transceiver System
FCC	Federal Communication Commission
FNE	Fixed Network Equipment
FOA	First Office Application
FORNet	Fiber Optic Repeater Network
FRU	Field Replaceable Unit
GR	General Release
GUI	Graphical User Interface
Hz	Hertz
iDEN	Integrated Digital Enhanced Network
IM	Inter Modulation
INI	Interference and Noise Indicator
IP3	3rd order Inter-modulation Product
ISC	Integrated Site Controller
KHz	Kilohertz
LAN	Local Area Network
MCRB	Multi-Channel RadioBlade
MHz	Megahertz
MOP	Method of Procedure
MS	Mobile Station
MTBF	Mean Time Between Failures
OLCC	On Line Configuration Change
OMC	Operations and Management Center
OMC-R	Operations and Management Center, Radio Subnetwork
PCCH	Primary Control Channel
PDU	Power Distribution Unit
RB	RadioBlade
RBD2	Two-Port RadioBlade
RF	Radio Frequency
RFN	RadioFrame Networks

Term	Definition
RSSI	Received Signal Strength Indicator
RX	Receive
SCCH	Secondary Control Channel
SNMP	Simple Network Management Protocol
SQE	Signal Quality Estimator
SR	Software Release
TBD	To be determined
TOR	Top of the Rack
TRD	Technical Requirements Document
TX	Transmit
UL	Underwriters Laboratories
WiDEN	Wideband iDEN

Appendix B. IP Address Requirements

The following table lists default IP addresses for RadioFrame Networks chassis boards, and the default IP address required for logging in to the MC-Series system.

Table 39 Address and Port Numbers for Chassis Boards

Device	Card Type	Chassis Slot/Port	IP Address	
Laptop	N/A	port 8	192.168.200.	253
BIC	CRIC	Slot 0	192.168.200.	5
	BPC	Slot 1	192.168.200.	6
	BPC	Slot 2	192.168.200.	7
	BPC	Slot 3	192.168.200.	8
AIC	CRIC	Slot 0	192.168.200.	20
	APC	Slot 1	192.168.200.	21
	APC	Slot 2	192.168.200.	22
	APC	Slot 3	192.168.200.	23
RBS	backplane	Group 1	192.168.200.	98
	backplane	Group 2	192.168.200.	99
	backplane	Group 3	192.168.200.	100

Appendix C. Medium Power iDEN Microcell Rack Stack-Up, 3-Sector (Default) Configuration

MC-Series Medium Power system cables are labeled with their terminuses at each end. They are routed, dressed and secured along the side of the system cabinet.

This appendix gives representations of intra-cabinet cabling for your reference. Table 40 through Table 48 list the connections for each component in the fully populated MC-Series Medium Power system. Figure 85 through Figure 88 show power, RF and data path connectivity for the system. Cables are shown splayed for clarity. The tables, which provide references for all connections, are keyed to the figures by Index codes. Please note that the Index codes have significance only within this appendix and do not correspond to cable or port labeling. Some connections are indicated in the figures only by destination Index. This is done if cabling is very similar to connections shown, and additional lines would clutter the diagrams.

Table 40 Cable Connections, Top of Rack Dual-Band Bulkhead, 3-Sector Configuration

From TOR:		To		Notes
Index	Label	Index	Label	
A	GND	--	--	To site ground; cable is customer supplied; lug is customer supplied—specified to be Panduit 2-hole, PN LCD6-14A, or equivalent
B	Tx800-3	RFS3:N	Tx 800 OUT	RF Tx 800, RF shelf # 3
C	Rx800-3	RFS3:K	Rx 800 IN	RF Rx 800, RF shelf # 3
D	Tx900-3	RFS3:BB	Tx 900 OUT	RF Tx 900, RF shelf # 3
E	Rx900-3	RFS3:M	Rx 900 IN	RF Rx 900, RF shelf # 3
F	Rx900-2	RFS2:M	Rx 900 IN	RF Rx 900, RF shelf # 2
G	Rx900-1	RFS1:M	Rx 900 IN	RF Rx 900, RF shelf # 1
H	Tx900-1	RFS1:BB	Tx 900 OUT	RF Tx 900, RF shelf # 1
I	Rx800-1	RFS1:K	Rx 800 IN	RF Rx 800, RF shelf # 1
J	Tx800-1	RFS1:N	Tx 800 OUT	RF Tx 800, RF shelf # 1
K	GPS1	iSC1:C	GPS	RF GPS, iSC # 1
L	GPS2	iSC2:C	GPS	RF GPS, iSC # 2
M	800-DIV-3	RFS3:Y	Rx 800 DIV IN	RF Rx 800, diversity; connected only to TOR . See NOTE 1.
N	800-DIV-2	RFS2:Y	Rx 800 DIV IN	RF Rx 800, diversity; connected only to TOR . See NOTE 1.
O	900-DIV-3	RFS3:AA	Rx 900 DIV IN	RF Rx 900, diversity; connected only to TOR . See NOTE 1.
P	900-DIV-1	RFS1:AA	Rx 900 DIV IN	RF Rx 900, diversity; connected only to TOR . See NOTE 1.
Q	900-DIV-2	RFS2:AA	Rx 900 DIV IN	RF Rx 900, diversity; connected only to TOR . See NOTE 1.
R	800-DIV-1	RFS1:Y	Rx 800 DIV IN	RF Rx 800, diversity; connected only to TOR . See NOTE 1.
S	Tx800-2	RFS2:N	Tx 800 OUT	RF Tx 800, RF shelf # 2
T	Rx800-2	RFS2:K	Rx 800 IN	RF Rx 800, RF shelf # 2
U	Tx900-2	RFS2:BB	Tx 900 OUT	RF Tx 900, RF shelf # 2

NOTE 1: Reserved for receive diversity option.

Figure 85 TOR Cabling (Underside View), Dual-Band 3-Sector MC-Series System

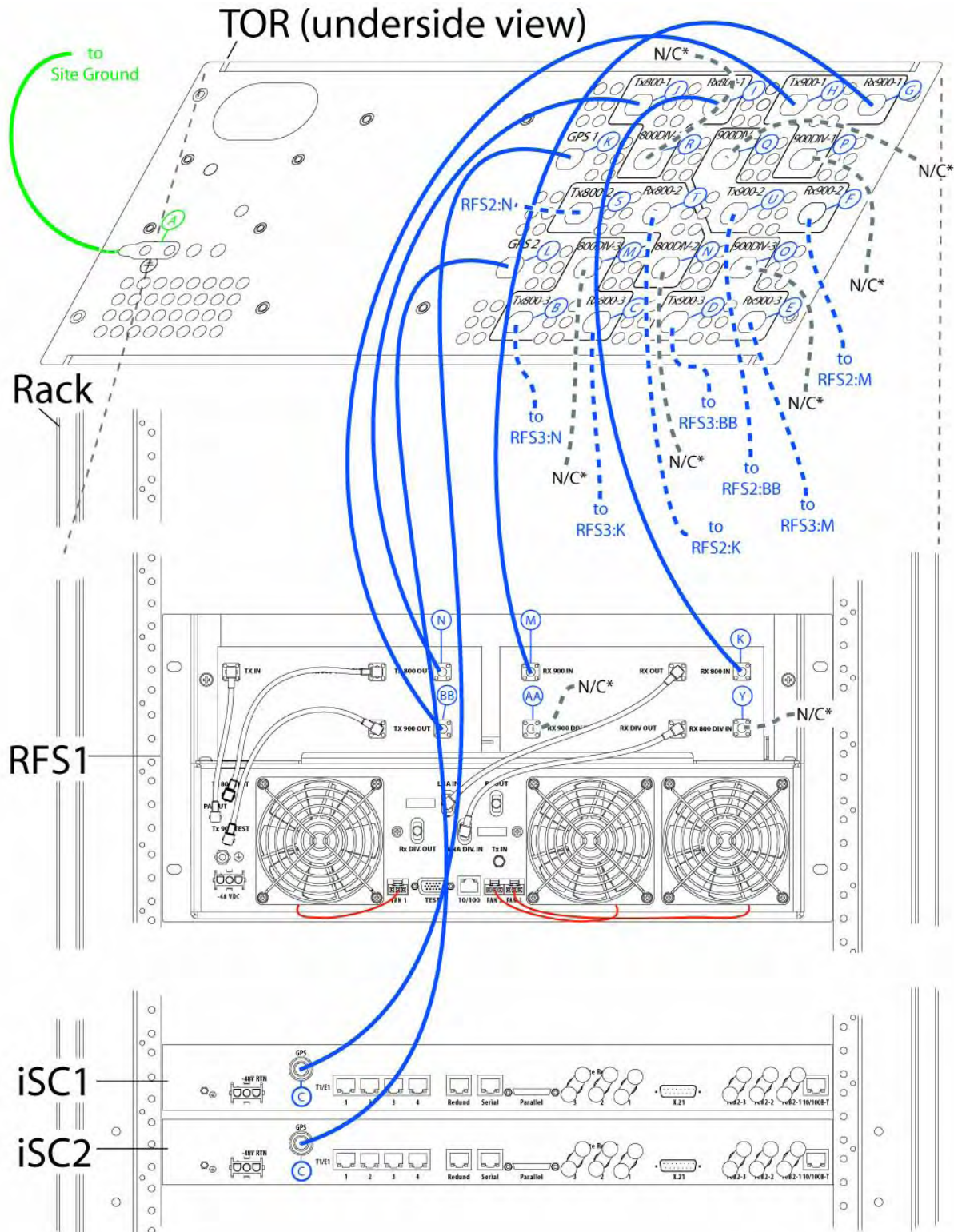

* These ports are reserved for receive diversity option. Leave cables attached only to TOR and secured.

Table 41 Cable Connections, RF Shelf, Dual-Band 3-Sector Configuration

From RFS1:		To		Notes
Index	Label	Index	Label	
A	GND	Rack:B	--	Ground, RF shelf #1
B	-48 VDC	PDU:E	RF 1	Power, RF shelf #1 -48 VDC
C	--	RFS1:D	FAN 1	Power, RF shelf #1, fan #1
D	FAN 1	RFS1:C	--	Power, RF shelf #1, fan #1
E	TEST			Not connected.
F	10/100	BIC:E5	ERTM Port 5	RF shelf #1 Status/Config. See NOTE 1. See NOTE 2.
G	FAN 2	RFS1:I	--	Power, RF shelf #1, fan #2
H	FAN 3	RFS1:J	--	Power, RF shelf #1, fan #3
I	--	RFS1:G	--	Power, RF shelf #1, fan #2
J	--	RFS1:H	--	Power, RF shelf #1, fan #3
K	Rx 800 IN	TOR:I	Rx800-1	RF Rx 800, TOR
L	Rx OUT	RFS1:U	LNA IN	RF Rx, LNA
M	Rx 900 IN	TOR:G	Rx900-1	RF Rx 900, TOR
N	Tx 800 OUT	TOR:J	Tx800-1	RF Tx 800, TOR
O	Tx 800 TEST OUT	RFS1:R	Tx 800 TEST	RF Tx 800, test
P	Tx IN	RFS1:Q	PA OUT	RF Tx, PA
Q	PA OUT	RFS1:P	Tx IN	RF Tx, PA
R	Tx 800 TEST	RFS1:O	Tx 800 TEST OUT	RF Tx 800, test
S	Tx 900 TEST	RFS1:CC	Tx 900 TEST OUT	RF Tx 900, test
T	Rx DIV OUT	--	--	Terminated, 50 Ω. See NOTE 3.
U	LNA IN	RFS1:L	Rx OUT	RF Rx, LNA
V	LNA DIV IN	RFS1:Z	Rx DIV OUT	RF receive diversity
W	Tx IN	RBS:N	Tx A	RF Tx, RadioBlade shelf, group A. See NOTE 4.
X	Rx OUT	RBS:M	Rx A	RF Rx, RadioBlade shelf, group A. See NOTE 5.
Y	Rx 800 DIV IN	TOR:R	800-DIV-1	RF Rx 800 diversity; connected only to TOR . See NOTE 6.
Z	Rx DIV OUT	RFS1:B	LNA DIV IN	RF Rx, LNA diversity
AA	Rx 900 DIV IN	TOR:P	900-DIV-1	RF Rx 900 diversity; connected only to TOR . See NOTE 6.
BB	Tx 900 OUT	TOR:H	Tx900-1	RF Tx 900, TOR
CC	Tx 900 TEST OUT	RFS1:Q	Tx 900 TEST	RF Tx 800, test

NOTE 1: The RF Shelf Status/Config segment is used in conjunction with MCRB.

NOTE 2: RF shelf #2 F and RF shelf #3 F, respectively, connected to BIC ERTM Port 6 and BIC ERTM Port 7.

NOTE 3: This port is reserved for the receive diversity upgrade. Leave terminated in system without receive diversity.

NOTE 4: RF shelf #2 W and RF shelf #3 W, respectively, connected to RBS Tx B and Tx C.

NOTE 5: RF shelf #2 X and RF shelf #3 X, respectively, connected to RBS Rx B and Rx C.

NOTE 6: This connector is reserved for the receive diversity upgrade. Leave cable disconnected.

Table 42 Cable Connections, RadioBlade Shelf, Dual-Band 3-Sector Configuration

From RBS:		To		Notes
Index	Label	Index	Label	
A	GND	Rack:E	--	Ground, RadioBlade shelf
B	10/100 RFN C	AIC:G3	ERTM PORT 3	Traffic path, Group C
C	ALARM INPUT C			Not connected. See NOTE.
D	FAN C	RBS:S	--	Power, RadioBlade shelf, fan C
E	POWER	PDU:G	RBS 1	Input power from power distribution unit
F	10/100 RFN B	AIC:G2	ERTM PORT 2	Traffic path, Group B
G	ALARM INPUT B			Not connected. See NOTE.
H	FAN B	RBS:Q	--	Power, RadioBlade shelf, fan B
I	REF CLOCK			Not connected
J	10/100 RFN A	AIC:G1	ERTM PORT 1	Traffic path, Group A
K	ALARM INPUT A			Not connected. See NOTE.
L	FAN A	RBS:O	--	Power, RadioBlade shelf, fan A
M	Rx A	RFS1:X	Rx OUT A	RF Rx, Group A
N	Tx A	RFS1:W	Tx IN A	RF Tx, Group A
O	--	RBS:L	FAN A	Power, RBS shelf, fan A
P	Tx B	RFS2:W	Tx IN B	RF Tx, Group B
Q	--	RBS:H	FAN B	Power, RBS shelf, fan B
R	Tx C	RFS3:W	Tx IN C	RF Tx, Group C
S	--	RBS:D	FAN C	Power, RBS shelf, fan C
T	Rx C	RFS3:X	Rx OUT C	RF Rx, Group C
U	Rx B	RFS2:X	Rx OUT B	RF Rx, Group B

NOTE: RF alarms communicated via Ethernet from RF shelves.

Table 43 Cable Connections, PDU, Medium Power 3-Sector Configuration

From PDU:		To		Notes
Index	Label	Index	Label	
A	GND	Rack:A	--	Ground, power distribution unit
B	-48VDC	--	--	Power, MC-Series rack; cable is customer supplied; lug is customer supplied—specified to be Panduit 2-hole, PN LCD6-14A, or equivalent
C	RETURN			
D	STATUS	EAS:J	CONTROL	Alarm feed, environmental alarm system
E	RF 1	RFS1:B	-48 VDC	Power, RF shelf #1
F	RF 2	RFS2:B	-48 VDC	Power, RF shelf #2
G	RF 3	RFS3:B	-48 VDC	Power, RF shelf #3
H	RBS 2			Not connected
I	RBS 1	RBS:E	POWER	Power, RadioBlade shelf
J	CSU	CSU:B	--	Power, CSU
K	CTRL 1	iSC1:B	-48 V	Power, primary iSC
L	CTRL 2	iSC2:B	-48 V	Power, secondary iSC
M	EAS	EAS:B	-48 V	Power, environmental alarm system
N	BIC	BIC:D	--	Power, BTS interface chassis
O	AIC	AIC:B	--	Power, airlink interface chassis
P	AUX1			Not connected
Q	AUX2			Not connected

Power and ground cabling for a fully populated system are illustrated in Figure 87 and Figure 88.

Figure 87 Power and Ground Connections, MC-Series Medium Power System, Fully Populated

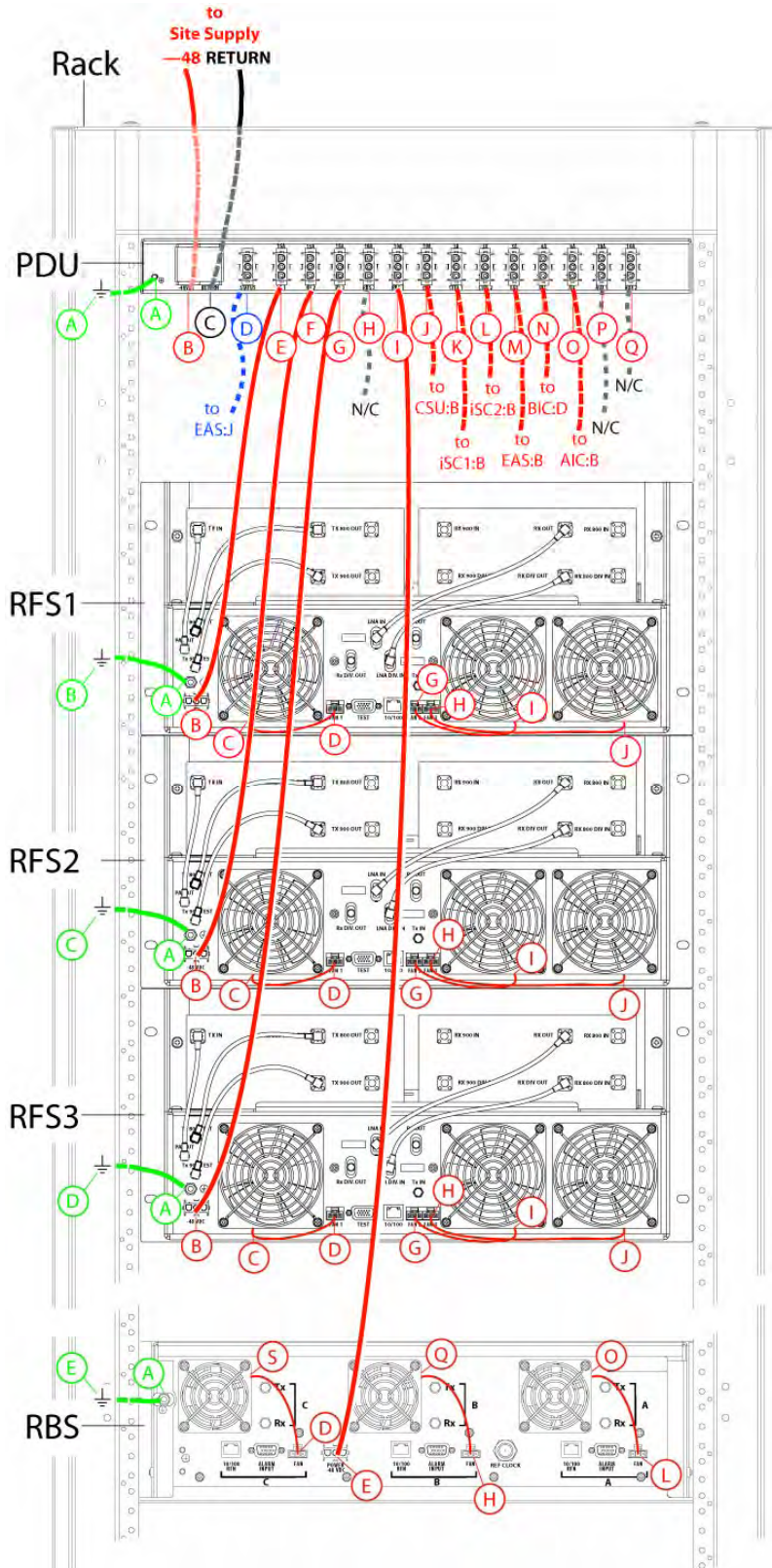

Table 44 Cable Connections, CSU, Dual Band 3-Sector Configuration

From CSU: (NOTE 1)		To		Notes
Index	Label	Index	Label	
A	GND	Rack:G	--	Ground, CSU
B	-48 V	PDU:K	CSU	Power, CSU
C-1 to C-8	LOW SPEED DATA			See NOTE 1.
D	HIGH SPEED DATA 2			See NOTE 1.
E	10/100 ETHERNET			See NOTE 1.
F	MEASUREMENT INPUTS			See NOTE 1.
G	INPUTS/RELAY			See NOTE 1.
H	CONTACT OUTPUTS			See NOTE 1.
I	T1/E1			See NOTE 1.
J	HIGH SPEED DATA 2			See NOTE 1.

NOTE 1: Connections external to the MC-Series system not shown. Configure the CSU according to the manufacturer's documentation and Sprint Nextel standards.

Table 45 Cable Connections, Primary iSC, Medium Power 3-Sector Configuration

From iSC1: (NOTE 1)		To		Notes
Index	Label	Index	Label	
A	GND	Rack:H	--	Ground, primary iSC; see NOTE 2.
B	-48 V	PDU:K	CTRL 1	Power, primary iSC; see NOTE 3.
C	GPS	TOR:K	GPS 1	RF GPS, primary iSC; see NOTE 4.
D-1	T1/E1 1	Splitter in line. See Note at right.		To splitter—daisy chained to secondary iSC, port T1/E1:1
D-2	T1/E1 2	Daisy chained. See Note at right.		To daisy chain—splitter at secondary iSC, port T1/E1:2
D-3	T1/E1 3			Not connected
D-4	T1/E1 4			Not connected
E	REDUND	iSC2:E	REDUND	Jumper to secondary iSC for redundancy
F	SERIAL			Not connected
G	PARALLEL	EAS:D	CONTROLLER A	
H	SITE REF OUT 3	iSC2:H	SITE REF OUT 3	Terminated BNC-T at iSC1 end; directly connected to port at iSC2:H
I	SITE REF OUT 2	iSC2:I	SITE REF OUT 2	Terminated BNC-T at iSC1 end; directly connected to port at iSC2:I
J	SITE REF OUT 1	iSC2:J	SITE REF OUT 1	Terminated BNC-T at iSC1 end;
K	X.21			Not connected
L1	10B2-3	iSC2:L	10B2-3	BNC-T at iSC1 end; connected to port at iSC2:L; connected to port at BIC:J
L2	10B2-3	iSC2:L	10B2-3	
M1	10B2-2	iSC2:M	10B2-2	BNC-T at iSC1 end; connected to port at iSC2:M; connected to port at BIC:B
M2	10B2-2	iSC2:M	10B2-2	
N	10B2-1	iSC2:N	10B2-1	BNC-T at either end; terminated at either end
O	10/100BT	iSC2:O	10/100BT	10/100B-T jumper

NOTE 1: Connections external to the MC-Series system not shown. Configure the primary and secondary iSC according to the manufacturer's documentation and Sprint Nextel standards.

NOTE 2: Secondary iSC ground to rack (Index Rack:I in Figure 88).

NOTE 3: Secondary iSC power to PDU (Index PDU:L in Figure 87).

NOTE 4: Secondary iSC GPS to TOR (Index TOR:L in Figure 85).

Table 46 Cable Connections, EAS, Dual-Band 3-Sector Configuration

From EAS: (NOTE 1)		To		Notes
Index	Label	Index	Label	
A	GND	Rack:J	--	Ground, EAS
B	-48 V	PDU:M	EAS	Power, EAS
C	USER ALARM CONTROL			Not connected
D	CONTROLLER A	iSC1:G	PARALLEL	Motorola cable PN
E	CONTROLLER B	iSC2:G	PARALLEL	Motorola cable PN
F	RF 2			Not connected
G	RF 3			Not connected
H	SYSTEM ALARM/CONTROL			Not connected
I	RF 1			Not connected
J	CONTROL	PDU:D	STATUS	Alarm, PDU

NOTE 1: Connections external to the MC-Series system not shown. Configure the EAS according to the manufacturer's documentation and Sprint Nextel standards.

Table 47 Cable Connections, BIC, Dual-Band 3-Sector Configuration

From BIC:		To		Notes
Index	Label	Index	Label	
A	GND	Rack:K	--	Ground, BTS Interface Chassis
B	CRTC2 10BASE2 – ISC	ISC1:M-2	10B2-2	Converted 10Base2 traffic path
C	CRTC2 10BASET – ISC	BIC:I-1	ERTM PORT 1	BIC ERTM to BIC CRTC
D	PO	PDU:N	BIC	Input power from power distribution unit
E-8	ERTM PORT 8	--	--	Remote management; external connection to DNX-1U (smart CSU)
E-7	ERTM PORT 7	RFS3:F	10/100 Port 1	RF shelf alarm
E-6	ERTM PORT 6	RFS2:F	10/100 Port 1	RF shelf alarm
E-5	ERTM PORT 5	RFS1:F	10/100 Port 1	RF shelf alarm
F	GPS ANT			Not connected
G	5MHz/1PPS OUT			Not connected
H	5MHz/1PPS IN	iSC1:J	Site Ref Out 1	Reference clock
I-4	ERTM PORT 4			Not connected
I-3	ERTM PORT 3			Not connected
I-2	ERTM PORT 2	AIC:G-4	ERTM PORT 4	AIC ERTM to BIC ERTM
I-1	ERTM PORT 1	BIC:C	10BASET – ISC	BIC ERTM to BIC CRTC
J	CRTC1 10BASE2 – ISC	ISC1:L-2	10B2-3	Converted 10Base2 traffic path
K	CRTC1 10BASET – ISC	BIC:I-3	ERTM PORT 3	BIC ERTM to BIC CRTC

Table 48 Cable Connections, AIC, Dual Band, 3-Sector Configuration

From AIC:		To		Notes
Index	Label	Index	Label	
A	GND	Rack:L	--	Ground, Airlink Interface Chassis
B	PO	PDU:O	AIC	Input power from power distribution unit
C-8	ERTM PORT 8			Not connected
C-7	ERTM PORT 7			Not connected. See NOTE 1.
C-6	ERTM PORT 6			Not connected. See NOTE 1.
C-5	ERTM PORT 5			Not connected. See NOTE 1.
D	GPS ANT			Not connected
E	5MHz/1PPS OUT			Not connected
F	5MHz/1PPS IN			Not connected
G-4	ERTM PORT 4	BIC:I-2	ERTM PORT 2	AIC ERTM to BIC ERTM
G-3	ERTM PORT 3	RBS:B	C 10/100 RFN	Traffic path, Group C
G-2	ERTM PORT 2	RBS:F	B 10/100 RFN	Traffic path, Group B
G-1	ERTM PORT 1	RBS:J	A 10/100 RFN	Traffic path, Group A

NOTE 1: These ports are reserved for receive diversity option.

Figure 88 Cabling, Site Controller and Interface Chassis, Dual-Band 3-Sector MC-Series System

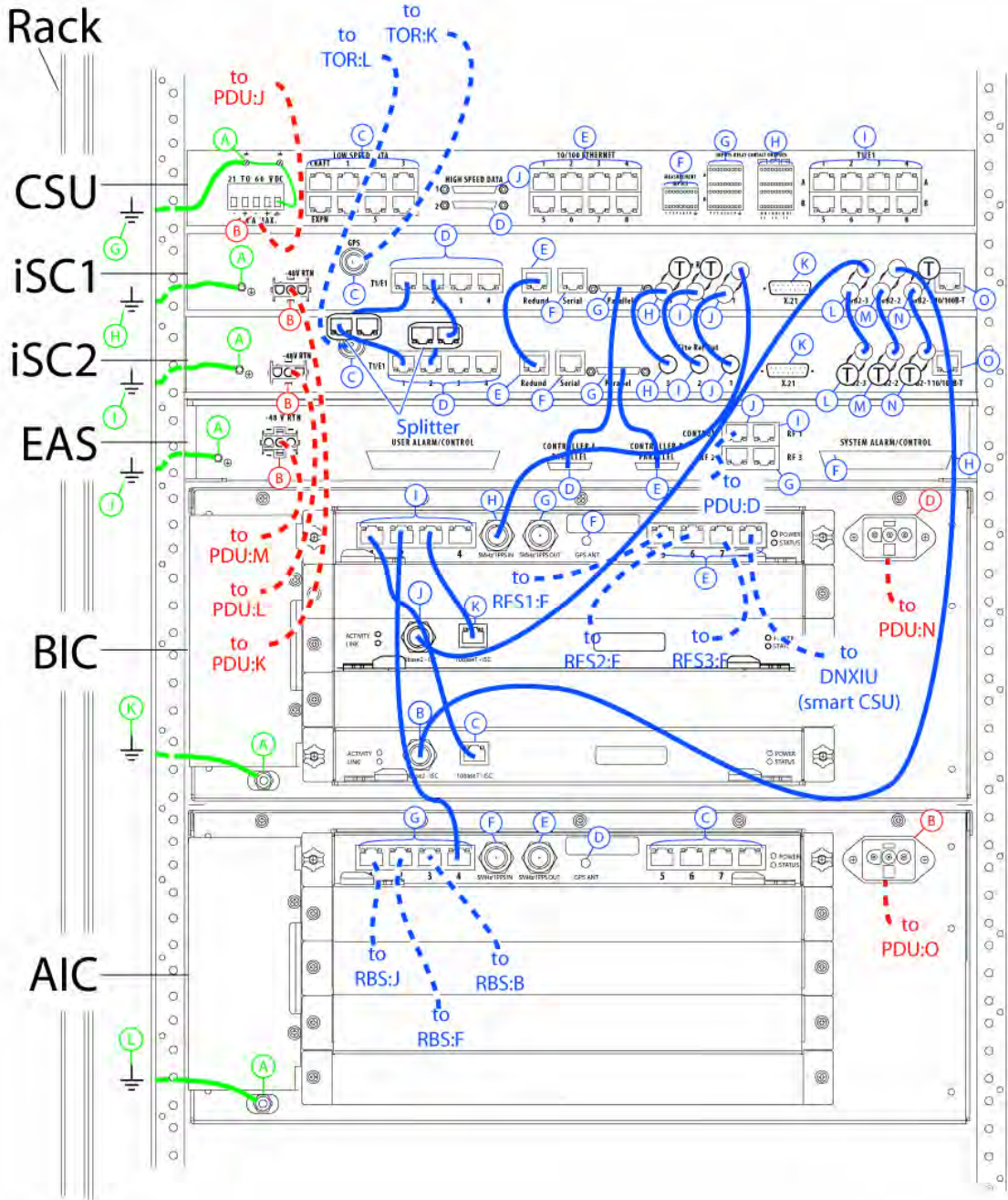

Appendix D. Functionality Test Procedures

D.1 Interconnect and Dispatch Setup and Voice Quality Testing

Interconnect and Dispatch voice quality will be assessed by evaluating voice links as described in Table 49, Table 50 and Table 51. RSSI and SQE measurements will be made via the handset. These tests are to be performed on a selected sample set of links.

Table 49 Interconnect Call Quality, Setup and Stability

Test #	MO/PSTN	Carrier #	RSSI (dBm)	SQE (dBm)	Quality (1-5)	Sector	Duration (Min)
1							2
2							2
3							2
4							2
5							2
	PSTN/MT						
1							2
2							2
3							2
4							2
5							2
	MO/MT						
1							2
2							2
3							2
4							2
5							2

Table 50 Group Dispatch Call Quality, Setup and Stability

Test #	MO/MT	Carrier #	RSSI (dBm)	SQE (dBm)	Quality (1-5)	Sector	Duration (Min)
1							2
2							2
3							2
4							2
5							2
6							2
7							2
8							2
9							2
10							2

Table 51 Private Dispatch Call Quality, Setup and Stability

Test #	MO/MT	Carrier #	RSSI (dBm)	SQE (dBm)	Quality (1-5)	Sector	Duration (Min)
1							2:30
2							2:30
3							2:30
4							2:30
5							2:30
6							2:30
7							2:30
8							2:30
9							2:30
10							2:30

D.2 Packet Data Service Connection and Latency

The Packet Data service will be tested and verified on the MC-Series system. Motorola's Packet Data Applet (laptop) will be used to connect to Sprint Nextel's Packet Data network over the MC-Series system, using a tethered connection with a Motorola handset.

Several samples of PING requests will be sent to a router in Sprint Nextel's Packet Data network and average round trip times will be recorded to measure latency. Table 52 presents the data to be collected for each ping using the MC-Series system. These tests shall be performed using Windows 2000 OS, and the timeout for each ping reply shall be set to 2000 milliseconds.

Table 52 Packet Data Latency over the MC-Series System (Ping -n 100 -w 2000 xx.xxx.xxx.x)

Test #	Handset	Carrier #	RSSI (dBm)	SQE (dBm)	Ping (No. Echos)	Router (IP Address)	Avg. Round-Trip Time (mSec)	Packet Loss (%)
1					100	xxx.xxx.xxx.x		
2					100	xxx.xxx.xxx.x		
3					100	xxx.xxx.xxx.x		
4					100	xxx.xxx.xxx.x		
5					100	xxx.xxx.xxx.x		

Table 53 presents (baseline) data collected for each ping using a Motorola Macrocell in order to average Round Trip time over the MC-Series System versus over Motorola standard Base Station equipment.

Table 53 Packet Data Latency over Motorola EBTS

Test #	Handset	Carrier #	RSSI (dBm)	SQE (dBm)	Ping (No. Echos)	Router (IP Address)	Average Round-Trip Time (mSec)	Packet Loss (%)
1					100	xxx.xxx.xxx.x		0
2					100	xxx.xxx.xxx.x		0
3					100	xxx.xxx.xxx.x		0
4					100	xxx.xxx.xxx.x		0
5					100	xxx.xxx.xxx.x		0

D.3 Short Message Service

The Short Message Service (SMS) will be tested and verified by initiating the delivery of a voice mail notification to the handset via one of the iDEN RadioBlade transceiver links.

- 4 Navigate on a network connection to the Internet.
- 5 Enter <http://www.sprint.com/> in the web browser.
- 6 On the Sprint Nextel home page, in the "Send a Text Message" box near the bottom, enter the 10-digit Nextel phone number of the test phone. The browser will display the mobile messaging page.
- 7 Enter a short text message into the field for message, and also enter a subject in the subject line.
- 8 Press the Send button.

The message should appear on the test phone within a few minutes.

D.4 Handover and Cell Reselection

Handover and Cell Reselection verifies that mobiles on the MC-Series system successfully handoff to the macro-cellular network during an interconnect call. These tests also verify that mobiles on the MC-Series system perform successful cell reselection when in an idle state. Table 54 presents the data to be collected for the handover and reselection tests.

Table 54 Handover and Reselection Test Worksheet

Test #	Handover (Mobile #)	Carrier # from (HEX)	Carrier # to (HEX)
1			
2			
3			
	Cell Reselection (Mobile #)		
1			
2			
3			

D.5 Interconnect Connection Stability and SQE Performance

A single link for 3:1 Interconnect should be maintained for 30 minutes each. Table 55 presents the data to be collected for each selected link. The iDEN Field Test Application (IFTA) is used in “Single Cell” mode to observe the SQE performance and plotted over time.

Table 55 Interconnect Connection Stability Worksheet

Interconnect #1	Carrier #	RSSI (dBm)	SQE (dB)	Sector	Duration (min)
					30
Interconnect #2					
					30
Interconnect #3					

D.6 Dispatch Connection Stability

To verify Dispatch connection stability, a Dispatch (private or group) call should be maintained for several minutes. Table 56 presents the data to be collected for each dispatch call.

Table 56 Dispatch Connection Stability Worksheet

Dispatch #1	Carrier #	RSSI (dB)	SQE (dB)	Sector	Quality (1-5)	Duration (min)
						3
Dispatch #2						
						4
Dispatch #3						
						5

D.7 Idle SQE Testing and Validation

Using the iFTA tool in “Single Cell” mode, record the idle RSSI and SQE values for the control channel for at least one hour per sector, while the mobile remains fixed.

Then, conduct the same procedure while walking the facility for approximately 15 minutes.

D.8 System Self-Recovery Test

The following test is to determine the ability of the MC-Series system to recover from various iSC-3 conditions.

1 Loss of T1

While the MC-Series system is operating, disconnect the T1 connection to the iSC-3 for one minute, and then reconnect it. Monitor the system recovery, and then validate the system by placing a successful call on each sector.

2 iSC-3 Power Loss

While the MC-Series system is operating, the iSC-3 shall be power cycled and system recovery will be monitored and validated by placing a successful call on each sector.

3 Loss of GPS

While the MC-Series system is operating, the GPS connection to the iSC-3 will be disconnected until all Satellites are lost and then reconnected. System recovery will be monitored and validated by placing a successful call on each sector.

4 New datafill download

System recovery will be verified by pushing a new datafill download to the iSC-3.

D.9 Packet Data Stability and Throughput

The Packet Data stability and throughput to the Internet will be verified. A tethered Packet Data connection will be set up on a laptop and speed tested by using the www.bandwidthplace.com website. This continuous download of data stream will validate system stability and help to quantify user experience of Packet Data over the MC-Series system.

D.10 Validation of 'Unable to Key BR' Alarm

While the MC-Series system is operating, disconnect any system component, from the BIC to the RBS, and monitor the OMC to verify that MC-Series system generates the **“Unable to Key BR”** alarm.

The MC-Series system provides fault alarming and isolation within System Manager for individual components, which consists of detecting catastrophic faults that prevent an MC-Series system component from responding to a periodic “ping”. All fault alarms generated by the MC-Series system are received at the OMC via the iSC. The “Unable to Key BR” alarm will appear at the OMC as minor, major or critical as follows (for more information about alarms, refer to section 7.5.3 “System Manager Alarms”):

Table 57 “Unable to Key BR” Alarm Severity Indications

“Unable to Key BR” Alarm Severity	Indication
minor	An iDEN RadioBlade transceiver has failed.
major	An RF Shelf has failed.
critical	A card in a chassis unit has failed (except for the BIC CRIC, which is responsible for returning the alarm information.)

Appendix E. Tx / Rx Curves

The 800 MHz Tx filter frequency response is shown in Figure 89.

Figure 89 800E Band Transmit Filter Frequency Response

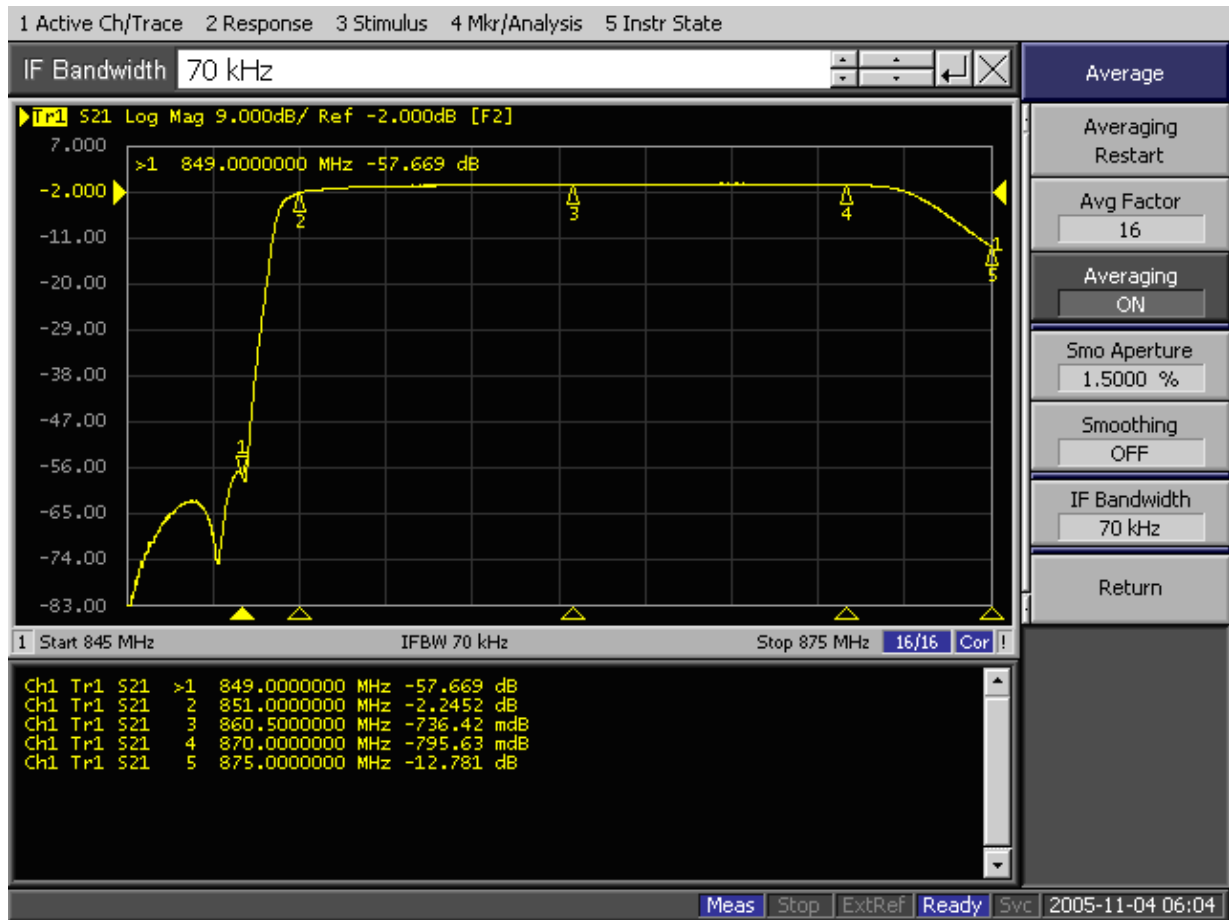

The 900MHz Tx filter response is shown in Figure 90.

Figure 90 900 MHz Transmit Filter Frequency Response

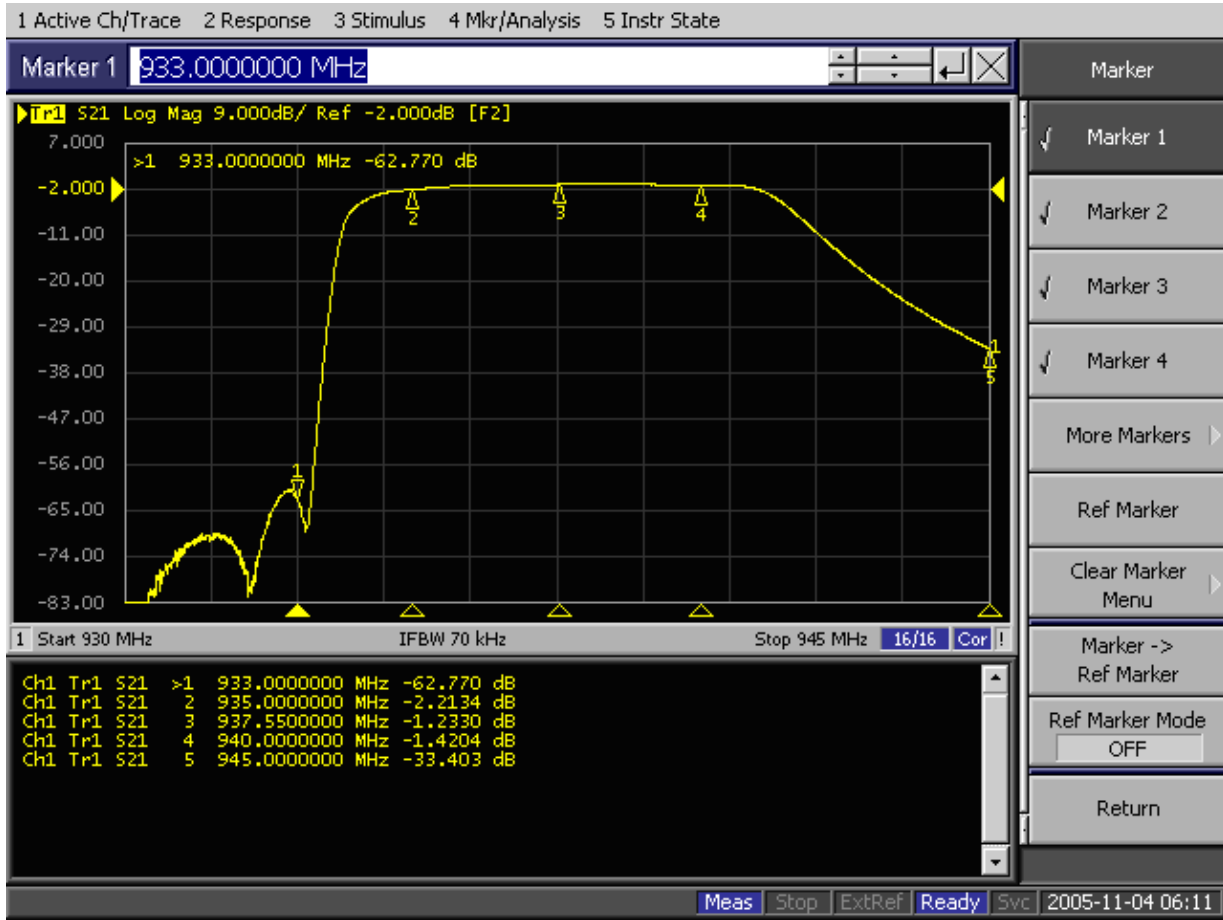

Figure 91 800E Band Rx Filter Response

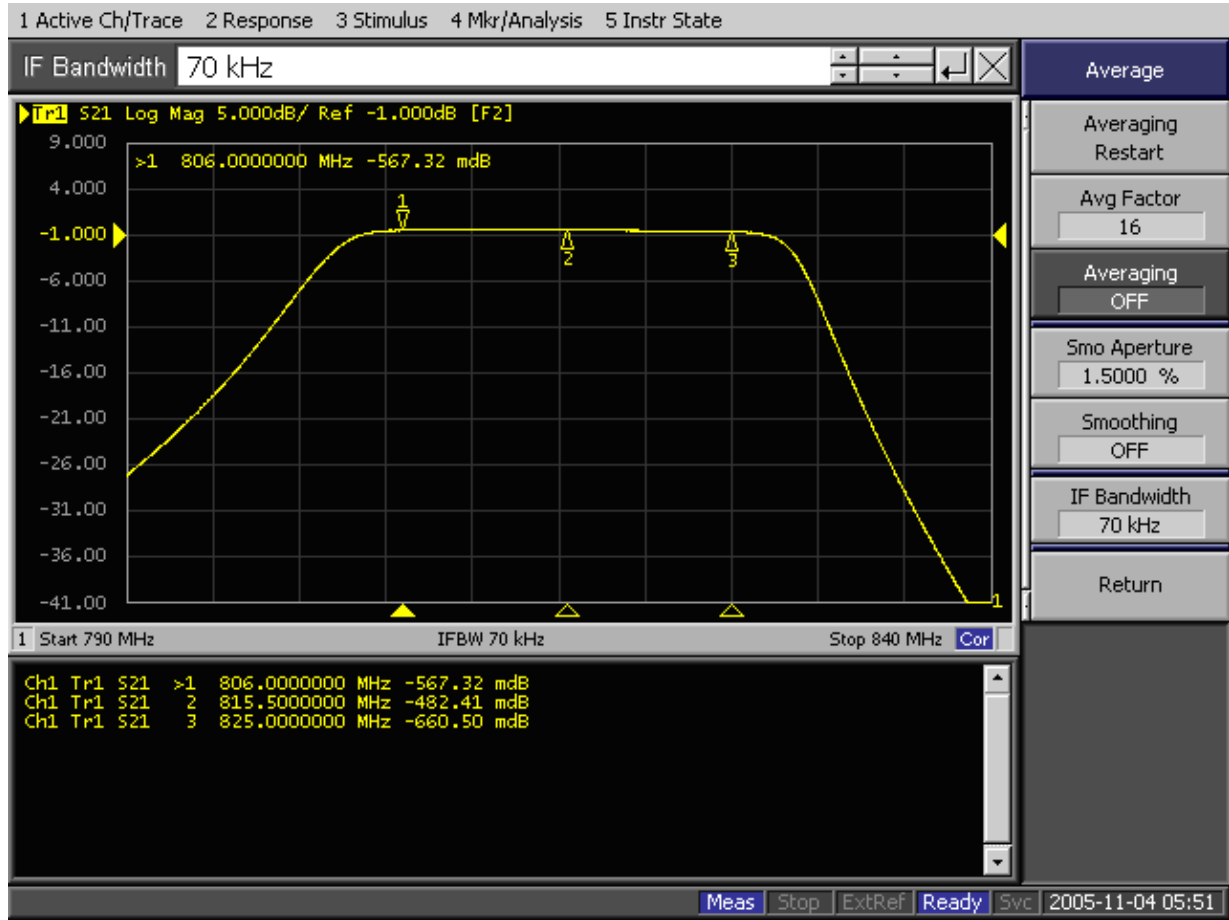
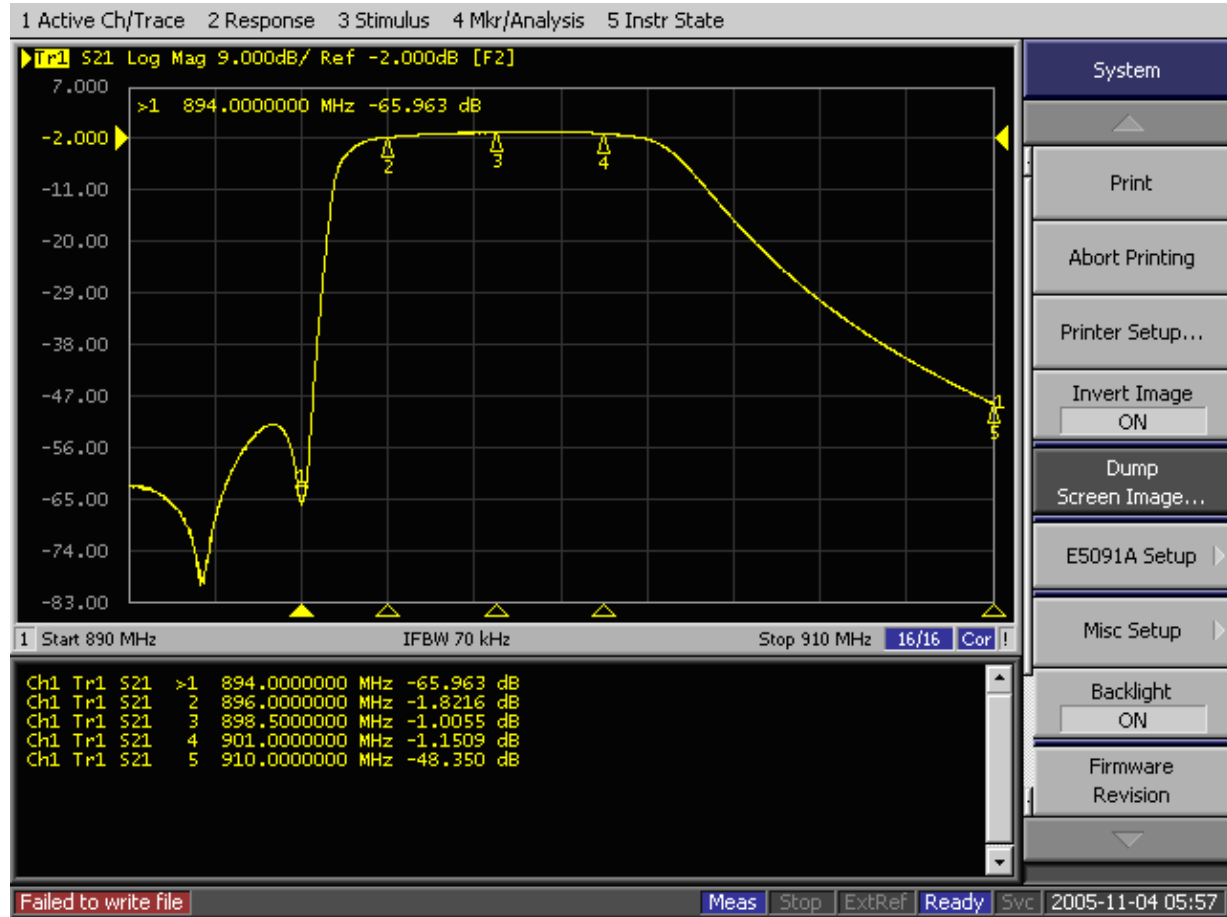

Figure 92 900 MHz Band Rx Filter Response



Appendix F. BER Test Procedure

The Bit Error Rate (BER) Diagnostic Test is used to execute BER tests of the MC-Series system. The Diagnostic Test supports multi-channel RadioBlade (MCRB) transceivers in both the 900 MHz band and the 800 MHz bands and also two-port, 800-band RadioBlade® (RBD2) transceivers. BER testing gives a pass/fail determination for each blade and should be performed on all blades in the RadioBlade shelf (RBS).

The most common testing scenario involves acceptance-test plan (ATP) execution during incoming inspection and commissioning. The MC-Series system can be taken out of service for testing during a maintenance window. The RadioBlade transceivers can be locked as a group and then unlocked one-by-one for the BER tests.

F.1 Prerequisites for Testing

These procedures presume that the MC-Series system is in place at its site of service and operational. Therefore, the prerequisites for operation will already have been satisfied:

- The T1 is live and has been tested.
- The datafill has been completed, including BR cabinet and position assignments, and conforms to the recommended datafill.
- All site cabling and installation work has been completed and all punchlist items corrected.
- The system is powered and operational.
- The software is at least Revision 14.x.xxx.

In addition, the following conditions are required for BER testing:

- The BER test requires that the RadioBlade Shelf be connected to an ISC.
- The RadioBlade transceiver under test must be in the active state and unlocked (UEA).

F.2 Test Tool

- Signal generator (sig gen)
A Motorola R2660 Communications Analyzer can be used as the source of the test signal for the MC-Series system during the BER test.

F.3 Testing Strategy

In the MC-Series system as in the Motorola Enhanced Base Transceiver Station (EBTS), BRs are identified by cabinet and position, with frequencies assigned in the datafill. BRs in the MC-Series are logical instances that map to physical RadioBlade transceivers. RBD2 and the MCRB transceivers can be mixed in a system (on a single RBS), and both the RBD2 and the MCRB can operate in a Quad BR configuration. Like the EBTS, the MC-Series system can be organized as a single sector (Omni), or as two or three sector site.

The basic BER testing strategy is to record the Base Radio (BR) and corresponding RadioBlade configuration of the MC-Series system, and then test each blade across the power spectrum in its assigned range(s) of frequency.

BER Test on an RBD2

An RBD2 maps one-to-one to a BR. Therefore, when testing an RBD2, you set the test frequency to the provisioned BR frequency.

BER Test on an MCRB

Because the MCRB supports up to six carriers, the BR to RadioBlade transceiver ratio can range from one-to-one up to six-to-one. BER testing confirms the functionality of the blade hardware itself at selected frequencies and sensitivity levels, allowing you to check functionality specifically in the assigned ranges.

The MCRB can be viewed as a broadband RadioBlade transceiver in which up to six iDEN carriers are set up in a 1.25 MHz band centered at an optimal frequency. When testing an MCRB transceiver, the BER test start page allows an optional center carrier to be entered. By default, if only a carrier (no center carrier) is specified for the BER test, the test will be done at that specified carrier, with the band centered on the specified carrier. Entering both a carrier and a center carrier allows BER testing to be done at non-center carriers.

The procedures in this guide cover BER testing of the full complement of RadioBlade transceivers. The BER testing methodology proceeds from sector to sector, testing each cabinet shelf and position in succession. Figure 93 summarizes the process.

Figure 93 BER Test Flow

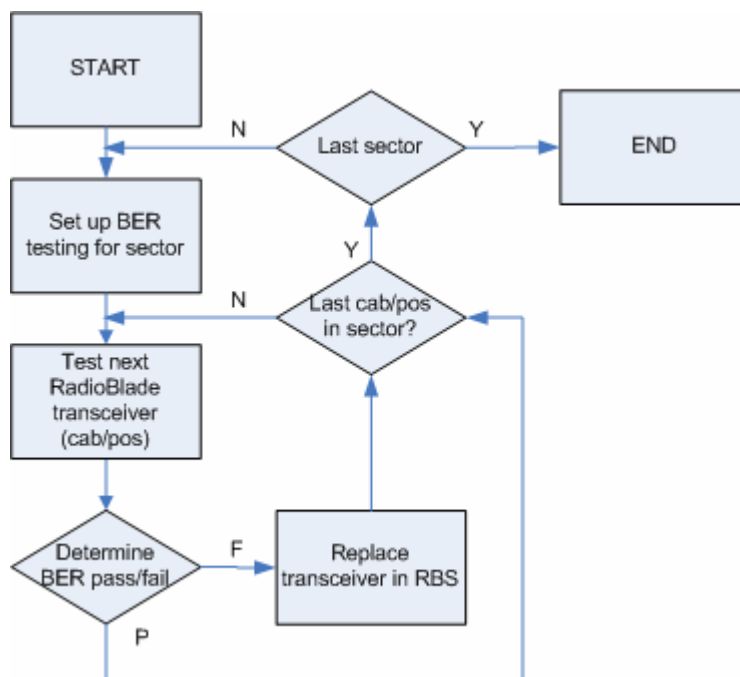

F.4 Equipment Connection/Setup

Set up the equipment to measure Rx BER as follows:

- 1 Connect a laptop to port 8 of the BIC CRIC using an Ethernet (CAT-5) cable.
- 2 Boot the laptop, start System Manager and log in.

- 3 Launch a browser session and then enter the MC-Series system IP address (<http://192.168.200.5>). Select the Performance Monitoring tab to display the login window. Type the User Name, (**Sysadmin**, case sensitive), and Password (**Radioframe**, case sensitive), and then select **OK**.

- 4 Connect Signal Generator to MC-Series System

Motorola R2660

On the R2660, set the 10 MHz STD toggle switch to INT and power it up.

Connect the TOR Rx port that is being tested (e.g., 900 Rx1 to test 900 MHz) to the RF IN/OUT or GEN OUT port on the R2660, depending on the desired test signal level.

Note: Attenuate as required.

F.5 BER Test Procedure

Commonly, the BER test is performed during the process of commissioning an MC-Series system, and the system has not yet been brought online. If the test is to be performed on a production system, the system must be taken out of service during a maintenance window.

For your notes during the BER tests, there is a test notes master form, Table 58, from which you can make copies. This form is useful both to organize your testing strategy and preserve the record of test results.

RadioBlade Transceiver Pre-Test

This section covers preparation for testing: determining the status of the RadioBlade transceivers in the system, taking the system out of service and preparing the blades and Sig Gen to run the tests. These steps presume that you are logged in to System Manager on the monitor laptop and that the Sig Gen is connected ("Equipment Connection/Setup), F.4.

- 1 Display the RadioBlade Control page (Figure 94). (To navigate to this page from the System Manager home page, click the Performance Monitoring tab and then click the RadioBlade Control link at the top of the iDEN Performance Monitoring page.)

Figure 94 RadioBlade Control Page

RB Slot	RB ID	RB PLL Status	State	Carrier ID	Trans. Freq.	Cabinet	Position	Locked/Unlocked
1	21:40	LOCKED	-	-	-	-	-	
	-	-	UEA	1	935018750	1	3	
	-	-	UEA	3	935043750	1	3	
	-	-	UEA	5	935068750	1	3	
	-	-	UEA	7	935093750	1	3	
	-	-	LEI	0	0	0	0	
	-	-	LEI	0	0	0	0	
2	65:44	LOCKED	-	-	-	-	-	
	-	-	UEA	12b	854737500	1	1	
	-	-	UEA	127	854687500	1	2	
	-	-	LEI	0	0	1	3	
	-	-	LEI	0	0	1	3	
	-	-	LEI	0	0	0	0	
	-	-	LEI	0	0	0	0	
3	2f:17	N/A (LOCKED)	LDI	N/A (0)	N/A (0)	1	1	
4	2e:a6	N/A (LOCKED)	LDI	N/A (0)	N/A (0)	1	2	
5	2f:2a	N/A (LOCKED)	LDI	N/A (0)	N/A (0)	0	0	
6	2f:eb	N/A (LOCKED)	LDI	N/A (0)	N/A (0)	0	0	

RadioBlade transceivers are listed on the RadioBlade Control page by slot number (1 through 24). If a RadioBlade transceiver is **administratively locked**, the icon in the **Locked/Unlocked** column is closed. If the RadioBlade transceiver is unlocked, the lock is open.

- 2 For reference in restoring the original system configuration, record in your notes which RadioBlade transceivers are administratively locked.
- 3 Lock any unlocked RadioBlade transceivers so that none of them is transmitting. To lock a RadioBlade transceiver, select its open lock icon, and, when prompted, select **Accept**. Or you can use the **lock all** hot link to administratively lock all blades with one command.

RadioBlade Transceiver BER Test

This section covers the method to use to measure receiver BER and determine whether each RadioBlade transceiver passes. Testing is organized by sector to minimize the need to move the Sig Gen leads. Because you are testing an MC-Series system that is not in service, you can simply leave the leads connected to the sector Rx port at TOR for the duration of the tests on that sector. The testing method follows a nested loop (summarized in F.3, "Testing Strategy") until all blades either pass or fail. Once testing on a given RadioBlade transceiver has been completed (step 7), you repeat the test steps for the next transceiver. Once a given sector is completely tested, you move the leads to the next sector input port and repeat the test for each blade in the next sector.

- 1 Set the Motorola R2660 to generate an in-bound 1 x 6 test signal at the desired frequency and signal level into the Rx port that corresponds to the RadioBlade transceiver to be tested.
- 2 Determine the receive sensitivity threshold. Start at -120 dBm, and then increase in 2 dB increments until the BER drops below 2%. The receive sensitivity value should be less than -106 dBm at 2% BER.
- 3 Determine the max. level threshold. Start at -48 dBm and increase in 2 dB increments until the BER goes above 2%. The maximum input power should be greater than -40 dBm at 2% BER.
- 4 If either of the values called for in steps 2 and 3 is not attained, the RadioBlade transceiver has failed specifications and should be replaced.
- 5 Display the RadioBlade Control page (Figure 94), and make sure the RadioBlade transceiver that is to be tested is not locked. If it is locked, unlock it.
If you are unlocking the blade, refresh the page every 30 seconds until the State of the RadioBlade transceiver has changed to 'UEA', approximately 3 minutes.
- 6 Select the Diagnostics tab (Figure 95), and then select **Bit Error Rate Test**.

Figure 95 System Diagnostics Page

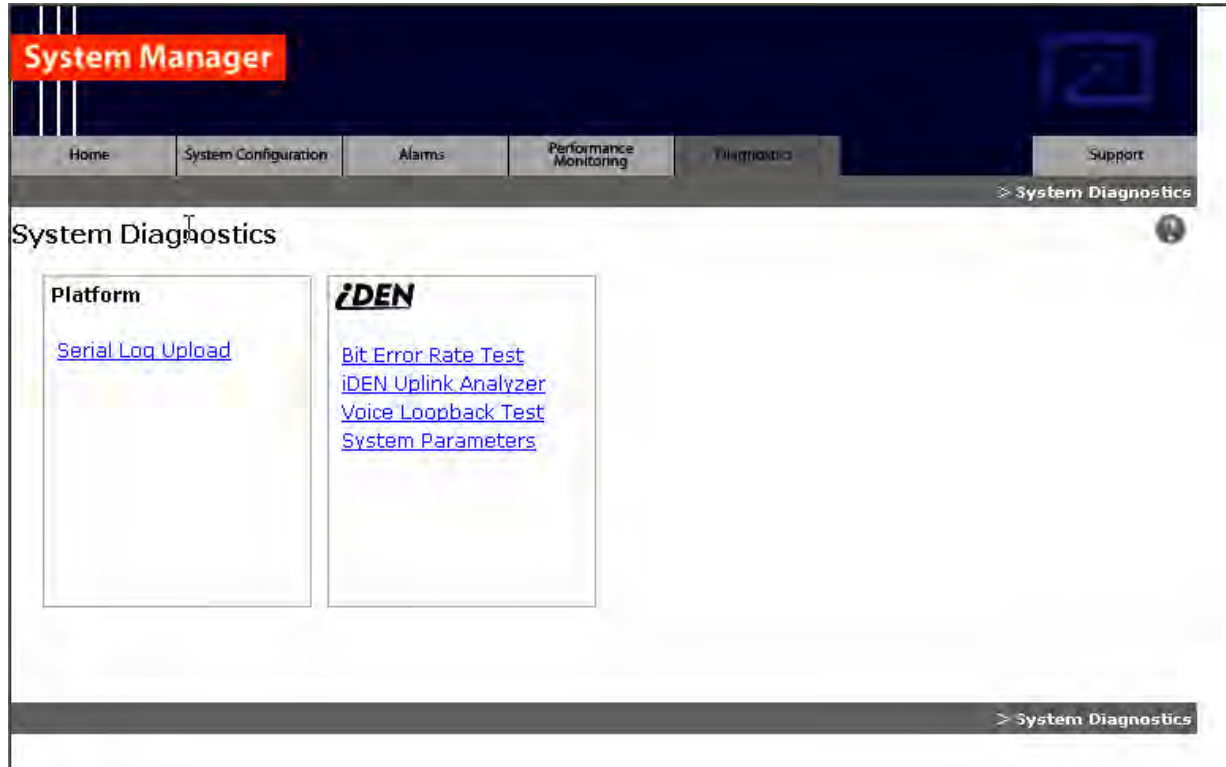

- 7 On the **Bit Error Rate Test** page (Figure 96), select the RadioBlade transceiver that is to be tested.

Figure 96 Bit Error Rate Test Page

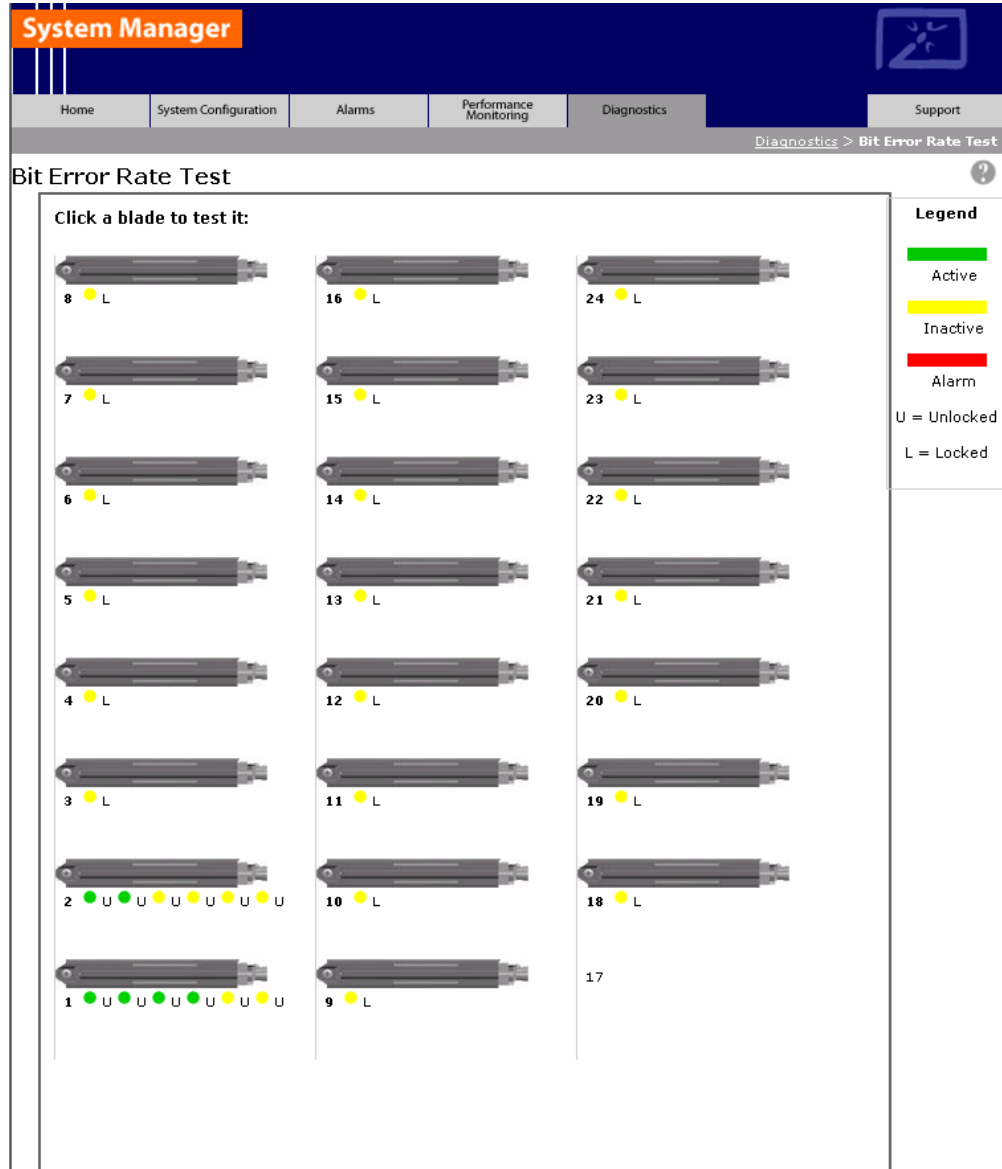

The **Start Test** page is formatted as shown in “BER Test on an MCRB” in section F.3 explains the use of the center carrier in BR testing with the MCRB.

- 8 Figure 97. Optionally, if the blade you are testing is an MCRB, you can enter a **Center Carrier** (in decimal format); if no value is entered in this field, the band will be centered on the specified carrier. Enter the **Carrier ID** (in decimal format) to which the Sig Gen is set, and then select the **Start Test** button.

“BER Test on an MCRB” in section F.3 explains the use of the center carrier in BR testing with the MCRB.

Figure 97 Bit Error Rate Start Test Page

System Manager: Bit Error Rate Test (RadioBlade 1) - Microsoft Internet Explorer provided by RadioFrame Networks, Inc.

Address: http://192.168.200.5/diagnostics/ber_test_run.html?ber_br=5&brtype=mcrb

System Manager

Home | System Configuration | Alarms | Performance Monitoring | **Diagnostics** | Support

Diagnostics > Bit Error Rate Test > RadioBlade 1

Bit Error Rate Test (RadioBlade 5)

Frequency Band:
 800 Mhz
 900 Mhz

Carrier ID: (decimal format)

Optional Center Carrier for MCRB: (decimal format)

Duration: (seconds)

Test Status: Running

[< Run the BER test on another blade](#)

Carrier (Decimal)	1	Value	Average	CumlAvg
Rx Frequency	806.0125 MHz	BER	0.00 %	0.06 %
Tx Frequency	851.0125 MHz	SQE	31.33	29.70
Rx Center Frequency	736.5000 MHz	RSSI	-69.65	-70.21
Tx Center Frequency	886.0000 MHz	Test Status	Running	

BER	SQE	RSSI	rBER	rSQE	rRSSI	cBER	cSQE	cRSSI	badBER	Pass
0.14	32.00	-71.55	0.06	29.55	-70.37	0.05	30.47	-70.12	1	23
0.00	31.29	-70.77	0.06	29.89	-70.37	0.05	30.48	-70.13	1	23
0.14	32.00	-70.11	0.06	30.26	-70.32	0.05	30.48	-70.13	1	23
0.29	28.96	-70.29	0.09	30.37	-70.27	0.05	30.48	-70.13	1	24
0.00	29.69	-68.04	0.07	30.51	-70.01	0.05	30.47	-70.12	1	24
0.43	29.41	-69.49	0.11	30.35	-70.00	0.06	30.47	-70.12	1	24
0.00	32.00	-69.66	0.11	30.58	-69.87	0.05	30.48	-70.11	1	24

[Copy log to clipboard](#)

Diagnostics > Bit Error Rate Test > RadioBlade 1

Done

- 9 Verify that the displayed **Rx Frequency** matches the desired receive frequency.
- 10 Approximately every second, the page reports the current BER measurement (**BER**) and the running average of the ten latest BER measurements (**BER Avg**). Record these results, and then select the **Stop Test** button.
 - Note:** If the warning “Test Signal Timing Out of Lock” appears, cycle power to the R2660 and set it up again to generate an in-bound 1x6 test signal at the desired frequency and signal level into the Rx port. It may take a few minutes for the R2660 test signal to stabilize.
 - Note:** If the only BER measurements reported are 50%, NO DATA, or both, verify that all procedure steps have been completed. If no problems are found, cycle power to the R2660 and set it up again to generate an in-bound 1x6 test signal at the desired frequency and signal level into the Rx port. It may take a few minutes for the R2660 test signal to stabilize. If there's still no change after cycling power to the R2660, select the **Stop Test** button.
- 11 When the BER test is complete, lock the RadioBlade transceiver that was under test.
- 12 Display the RadioBlade Control page, and lock the RadioBlade transceiver by selecting its lock icon so that it is closed (locked). Refresh the page every 30 seconds until the **State** of the RadioBlade transceiver has changed to ‘2’.
- 13 Repeat Steps 1 through 11 for each RadioBlade transceiver to be tested on this Rx port.
- 14 Move the test leads to the next sector at TOR when all desired blades in the current sector have been tested and repeat the procedure.

F.6 Equipment Disconnection

Disconnect equipment after completing the BER testing.

- 1 Disconnect the R2660 from the Rx port under test.
- 2 Display the RBS Status page, and verify that all RadioBlade transceiver status icons are green.
- 3 Disconnect the network cable from port 8 of the BIC CRIC.

F.7 BER Test Notes Master

You can use this page to make copies of Table 58 for use as a handy organizer and permanent record of the BER tests.

Appendix G. Dangerous RF Emissions Precautions



Warning!

The MC-Series system has been approved for antennas up to +20 dBi. At energy levels within the approved range, operation may present hazards to life and health.

RF emission level is a function of the installation. Accordingly, it is the responsibility of the equipment owner, and not RadioFrame Networks, Inc., to apply signage to the site if it is required under 47 CFR 1.1310.

Please carefully read and observe the following warnings!

This equipment is designed to generate and radiate radio frequency (RF) energy by means of an external antenna. When terminated into a non-radiating RF load, the base station equipment is certified to comply with Federal Communications Commission (FCC) regulations pertaining to human exposure to RF radiation in accordance with the FCC Rules Part 1 section 1.1310 as published in title 47 code of federal regulations and procedures established in TIA/EIA TSB92, Report on EME Evaluation for RF Cabinet Emissions Under FCC MPE Guidelines, Compliance to FCC regulations of the final installation should be assessed and take into account site specific characteristics such as type and location of antennas, as well as site accessibility of occupational personnel (controlled environment) and the general public (uncontrolled environment). This equipment should only be installed and maintained by trained technicians. Licensees of the FCC using this equipment are responsible for insuring that its installation and operation comply with FCC regulations Part 1 section 1.1310 as published in title 47 code of federal regulations. Whether a given installation meets FCC limits for human exposure to radio frequency radiation may depend not only on this equipment but also on whether the “environments” being assessed are being affected by radio frequency fields from other equipment, the effects of which may add to the level of exposure.

Accordingly, the overall exposure may be affected by radio frequency generating facilities that exist at the time the licensee’s equipment is being installed or even by equipment installed later. Therefore, the effects of any such facilities must be considered in site selection and in determining whether a particular installation meets the FCC requirements. FCC OET Bulletin 65 provides materials to assist in making determinations if a given facility is compliant with the human exposure to RF radiation limits. Determining the compliance of transmitter sites of various complexities may be accomplished by means of computational methods. For more complex sites direct measurement of power density may be more expedient. Persons responsible for installation of this equipment are urged to consult the listed reference material to assist in determining whether a given installation complies with the applicable limits. In general the following guidelines should be observed when working in or around radio transmitter sites:



Warning!

All personnel should have electromagnetic energy awareness training.



Warning!

All personnel entering the site must be authorized.



Warning!

Obey all posted signs.



Warning!

Assume all antennas are active.



Warning!

Before working on antennas, notify owners and disable appropriate transmitters.



Warning!

Maintain minimum 3 feet clearance from all antennas.



Warning!

Do not stop in front of antennas.



Warning!

Use personal RF monitors while working near antennas.



Warning!

Never operate transmitters without shields during normal operation.



Warning!

Do not operate base station antennas in equipment rooms.
